



**FACULTAD DE INGENIERIA U.N.A.M.
DIVISION DE EDUCACION CONTINUA**

CURSOS INSTITUCIONALES

**DIPLOMADO GERENCIA DE PROYECTOS
ICA-DECFI, UNAM**

**Módulo III "Suministros"
24, 25 y 26 de junio de 1999**

"Suministro y Subcontratos"

Ing. John Baumanis
Palacio de Minería
1999

P.01 Introduction

- Safety Topic
- CPI Topic
- Fire Exits
- Messages
- Notes
- Wash Rooms
- Attendee Record

Procurement Organization

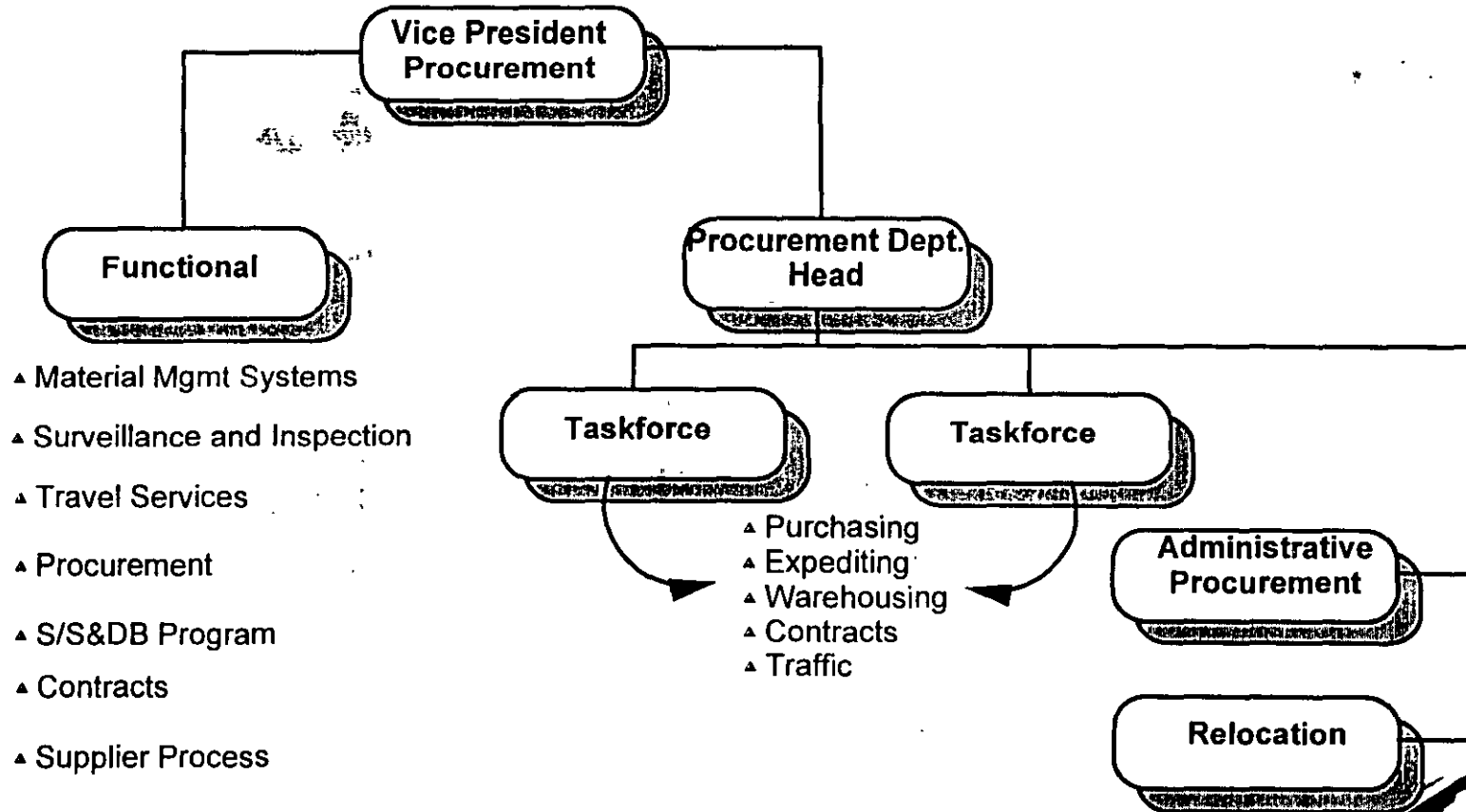

Part 0 Introduction

**Insert Procurement Functional Personnel Matrix and /
or Local Procurement Department Functional Matrix**

P.01 Course Agenda

Module 1	Project Procurement Planning
Module 2	Procurement Systems Overview
Module 3	Uniform Commercial Code (UCC)
Module 4	Terms and Conditions
Module 5	Request for Quotation
Module 6	Bid Analysis and Purchase Order Award
Module 7	Purchase Order Administration
Module 8	Expediting
Module 9	Surveillance
Module 10	Traffic
Module 11	Warehousing
Module 12	Field Procurement (Jobsite)

▲ Each module will be completed with a Module Review Exercise

PROCUREMENT 101

An Introduction to the Elements of Procurement

P101 MODULE ONE

Project Procurement Planning

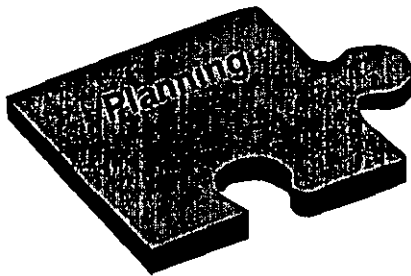

MODULE 1

Project Procurement Planning

Purpose: To provide a general understanding of how proper planning on a project contributes to successful project procurement execution services with an emphasis on:

- A. The Importance of Planning
- B. Project Planning
- C. Ethics
- D. Module Review Exercise



A. The Importance of Planning

What is it? Webster says a plan is a method of achieving an end.

Why plan?

- To streamline and improve execution
- On a typical "fast track" project we may have 80 to 400+ people that need to "march to the same drum"
- To provide services to our clients which are better, safer, cheaper and faster

A Procurement Plan addresses how we will perform all (or some) of the following functions

- | | | | |
|---------------------|----------------------|---------------|----------------|
| • Scope of Services | • Material Control | • Systems | • Surveillance |
| • Work Processes | • Supplier Selection | • Contracting | • Traffic |
| • Field Procurement | • Minority Business | • Warehousing | • Staffing |

Where do we look for guidance?

- | | |
|---------------------------------|--|
| • Procurement Practices Manual | • OPG - Operating Principles Guidebook |
| • Experience from Past Projects | |



B. Project Procurement PLANNING

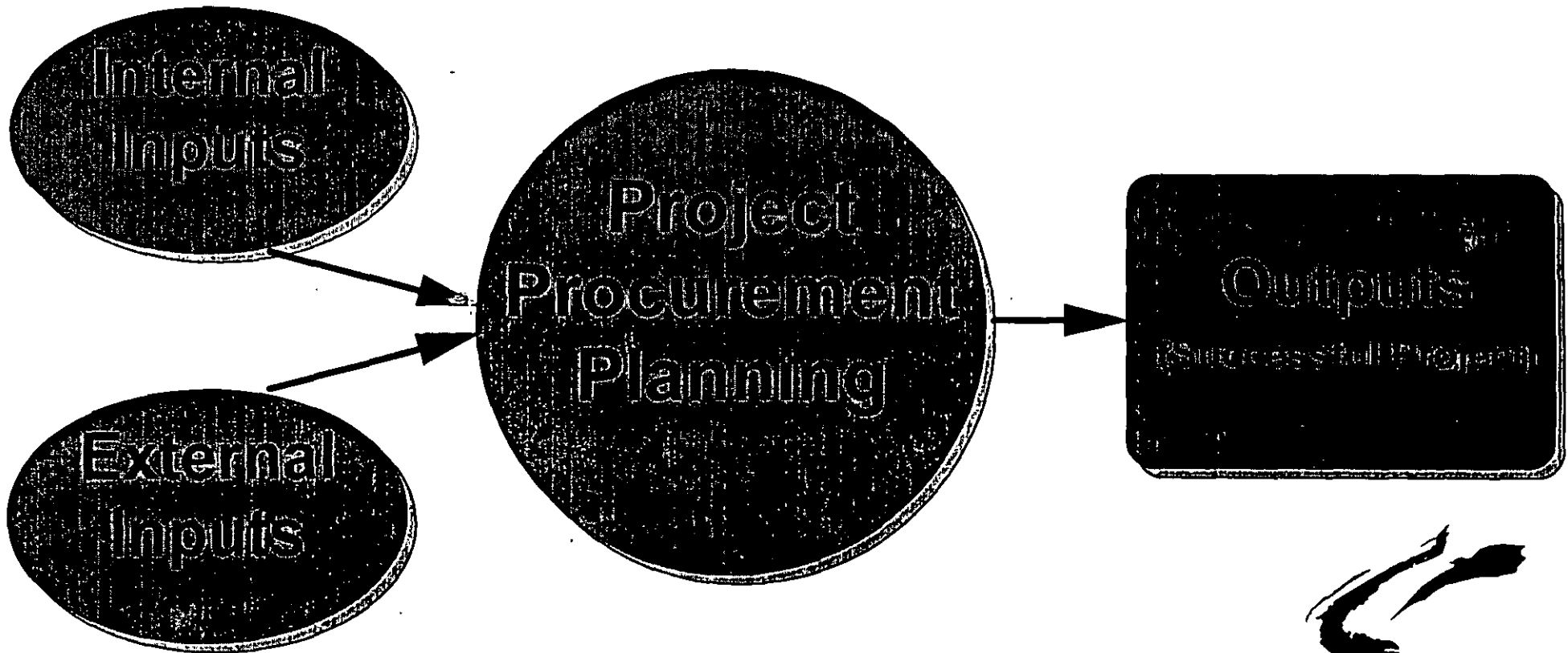

B. PROJECT PROCUREMENT PLANNING

Practices

Suppliers

Personnel

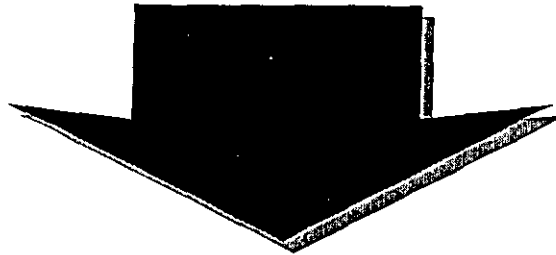

Internal
Inputs



B. Project Procurement Planning

Practices

Suppliers

Personnel

- Recommendations and Guidelines to use in our normal business day.
 - Procurement Practices Manual
 - Contracts Management Practices Manual
 - Warehouse Practices Manual
 - SQS User Reference Guide



B. Project Procurement Planning

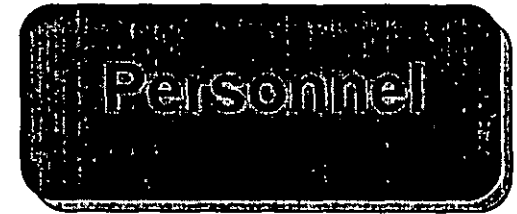

Where do we look to assist in supplier consideration?

- Key Suppliers
 - Contractual agreements between Fluor Daniel and Supplier.
 - Demonstrated leaders in their commodity.
 - Lowest total installed cost and best deliveries.
 - Early involvement to reduce redundancy between engineering and order entry.
- Client Contractual / Preferred Suppliers
- Technically Specific Suppliers
- Regional Supplier Data Base (provides opportunity to purchase locally)

How are suppliers validated?

- Supplier Ratings
- Shop Surveys (SQS)
- Caution List
- Financial References (Dun & Bradstreet)

How do we establish a Procurement strategy?

- Determine who supplies material and equipment (FD or ?)
- Review the types of packages with the suppliers being considered
- Determine single source vs competitive bid approach per package



B. Project Procurement Planning

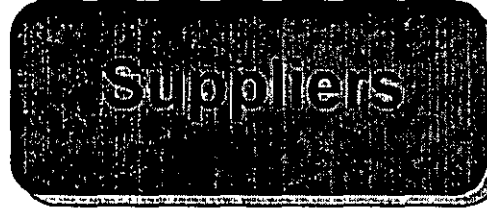

Personnel

Personnel are provided to the PPM by the Department Manager. Match the experience level and the number of people to the work.

Example: On a project where we have 110 purchase orders and 5 contracts, we probably need a stronger full time purchasing level of expertise and part time assistance from contracts administration specialists.

Performance Assessments

Roles and Responsibilities

The roles and responsibilities of employees must be defined.

Expectations

It is of vital importance to define expectations of employees during performance assessments. This process defines goals which the employee can pursue. This process also defines milestones upon which employees can be measured.

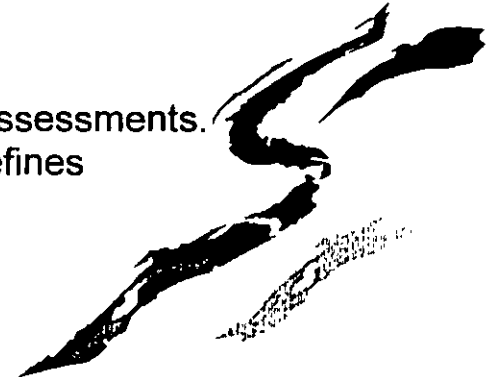

B. Project Procurement Planning

Engineering
Scope / SOW / Drawings

Project Controls
Est. / Spend / Cash

Client
(Prime Contract)

Contract
Management

Construction
Contracting
Field Staff

Project Management

Specific Considerations
• Monitoring
• Deliverables

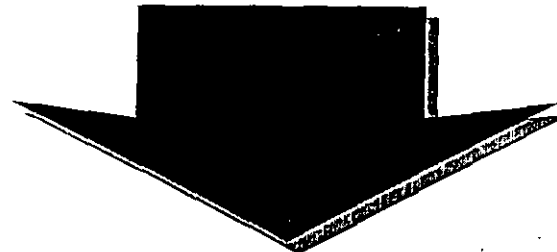

External Inputs



B. Project Procurement Planning

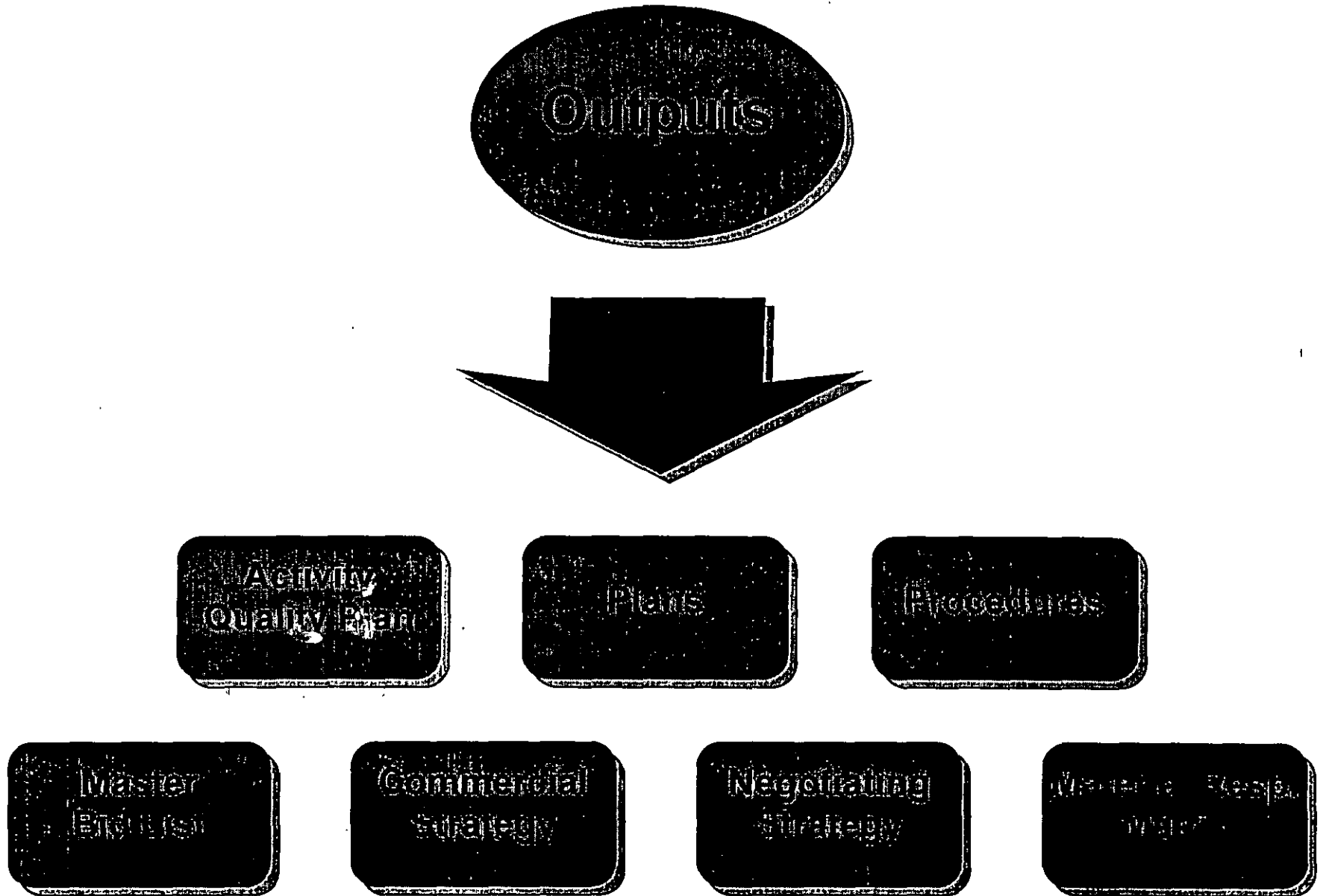

B. Project Procurement Planning

Activity
Quality
Plan

Plans

- ✓ Activity Quality Plan - AQP
 - A list of auditable key activities
- ✓ Plans
 - Material and Procurement Plan - describes scopes of services
 - Material Control Plan
 - ▶ Work process from engineering to field material issuance
 - ▶ MTO and bump factor philosophy per discipline
 - System Implementation Plan (see module 2)
 - ▶ Document systems that will be used
 - ▶ Develop work flow diagram as it relates to work process
 - Logistics Plan
 - ▶ FOB Terms
 - ▶ Material routing strategy
 - ▶ Special load considerations
 - Surveillance
 - ▶ Identifies the level of surveillance / inspection
 - ▶ Identifies orders to be inspected
 - Staffing Plan / Budget Estimate (3 ways to develop)
 - ▶ Estimate the number of hours per package per discipline
 - ▶ Estimate effort hours based on schedule (man-load process)
 - ▶ Procurement effort, approximately 8-10% of total home office.

Estimate Number of Hours Per Discipline

Identify the services and approx. hours required for each service:

Purchase / Expedite	25 hours
Traffic	5 hours
Inspection	10 hours
Total	40 hours

Identify the number of packages and multiply by hours / service or assume total hours / package

20 equipment P.O.'s @ 40 hours / package = 800 hours

Estimate Effort Hours Based on Schedule (man-load process)

Plot effort hours per Project Schedule

	Jan	Feb	Mar	Apr	May	Jun	Jul
Pkg. #1							
Purch.	—————						
Expe.		—————					
Insp.							
Traff.						———	
Pkg. #2							———
etc.							
	Total = 775 hours						

Estimate Based on 10% of Total Home Office Hours

Total engineering hours =
8000
10% of 8000 = 800 hours
Total = 800 hours

B. Project Procurement Planning

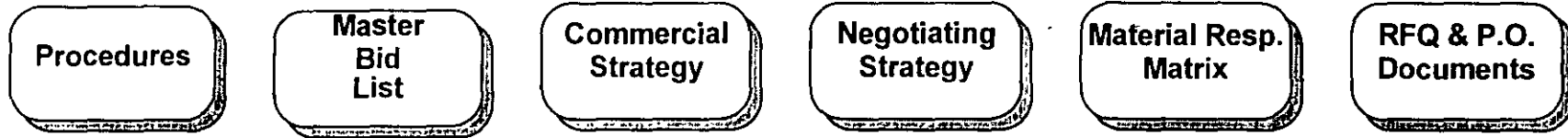

- ✓ Procedures - state how plans will be accomplished (required for each plan)
- ✓ Master Bidders List
 - Documents pre-qualified bidders from the supplier selection process
- ✓ Commercial Strategy
 - Incorporate flow down requirements from Prime Contract into RFQ and P.O. documents (i.e. warranty, insurance, agents, tax)
- ✓ Negotiating Strategy Philosophy
 - Schedule, payment terms, cost, spares, start-up services, shipping terms
- ✓ Material Responsibility Matrix
 - Identifies all material to be purchased and who is responsible (i.e. Fluor Daniel, Client, Contractor). Includes determining project blanket P.O. requirements (i.e. scaffolding, field purchases).
- ✓ RFQ and P.O. Documents
 - Start with master clauses and modify for project requirements (See Module 5)

B. Project Procurement Planning

Outputs

Who is responsible for Procurement outputs?

- Development
 - ✓ Project Procurement Manager
- Implementation
 - ✓ Project Procurement Team

Do Procurement outputs change during the execution of a project? Yes

- As scope deviates, the project team develops pro-active resolutions and revises the plans accordingly.
- Work process improvement

* It is always beneficial to keep auditing in mind when developing project plans and procedures. This can help streamline the auditing process.

* Always develop plans and procedures to match the requirements of the particular project. It is of no benefit to simply copy procedures from manuals or previous projects if they don't match the current situation.

C. Ethics

In Procurement and Contracts, it is our responsibility as business professionals to establish and communicate the ethical standards by which all other organizations can follow.

✓ Relations with Suppliers and Contractors

- Good relations between Flour Daniel and its suppliers and contractors can only be maintained through fair and courteous treatment.

✓ Confidential Information

- Technical
- Commercial

✓ Conflicts of Interest

- Employees should disclose any conflicts of interest and voluntarily remove themselves from situations that could be deemed as a conflict of interest.

✓ Gratuities

- Employees have the responsibility to ensure that they do not become obligated to any supplier or contractor by the acceptance of gifts, gratuities or special entertainment.

✓ Ethics Hotline

- 800-654-3360 (within California only)
- 800-223-1544 (outside California)

The Ethics Hotline is for the confidential reporting of suspected unethical or illegal conduct

D. Module Review Exercise

Fluor Daniel has been awarded a new "E.P.C.M." project. The project team has been identified and has had the first alignment session. The home office estimate has been established for all services. All plans, procedures, work processes and systems have been developed and set up. Scope definition identified that some of the following types of packages would be issued:

1. ANSI centrifugal pumps
2. Chilled Water centrifugal pumps (10 pumps P101 - P110, RFQ #GMS-A-001).
3. Carbon Steel and Stainless Steel pipe fabrication
4. Pipe, Valves and Fittings

What type of purchasing strategies should be considered?



D. Module Review Exercise

Answers

1. Single source with Key Supplier (Goulds) for ANSI centrifugal pumps.
(Obtain sole source approval)
2. Competitive bid the chilled water centrifugal pumps with 3 - 4 bidders.
3. Split the carbon steel and stainless steel pipe fabrication into separate packages and competitively bid them.
4. Home office to buy all valves. Home office to purchase bulk pipe and fittings from the first MTO representing approximately 80% of material required. Sub-Contractor should purchase the balance. Single source Key Supplier (McJunkin).



C. Work Process & System Integration

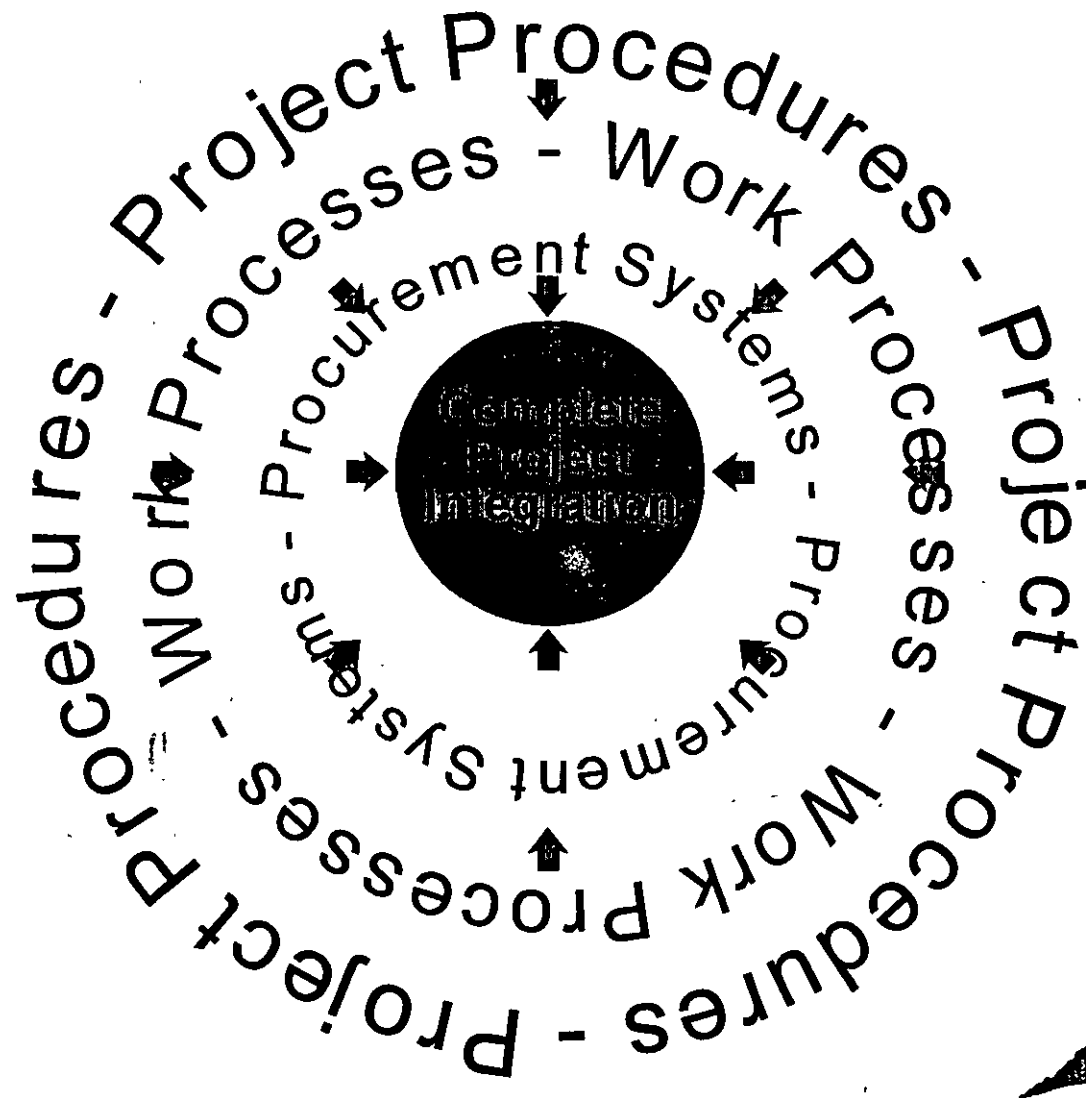

C. Work Process & System Integration

Procedures

- Planning - How does the project need to be managed
- Work Process
- Systems to support the work process
- Training/Communication
 - Project Management Strategy
 - Work Process Integration
 - Systems

Roles and Responsibilities

- Project Management Team
 - Project Strategy
 - Define Work Processes
- Systems Support
 - Implement the systems to support the project needs
 - Training

Material Manager / Coordinator

- Drives the Work Process
- Controls Material from "Cradle to Grave"



C. Work Process & System Integration

Project Implementation Strategy:

- Alignment
 - ✓ Material Manager with Other Disciplines
- Clauses
 - ✓ RFQ vs PO
 - ✓ Equipment vs Piping vs Electrical vs Instrumentation etc.
- Milestones
 - ✓ Critical / Complex Packages
 - ✓ "Off the Shelf" Packages
 - ✓ Bulk Material Packages
- Numbering & Naming Conventions
 - ✓ Package Numbers
 - ✓ Equipment Numbers
 - ✓ Commodity Numbers
 - ✓ Spares Identification etc.
- Reports
 - ✓ Type of Reports to be Issued
 - ✓ Frequency of Distribution
- Tracking
 - ✓ Types of Equipment to be tracked
 - ✓ Types of Commodities to be tracked
 - ✓ Level of detail
- Consistency
 - ✓ Numbering
 - ✓ Naming
 - ✓ Milestones
- Security
 - ✓ Disciplines Accessing Systems
 - ✓ Levels of Access
- Work Processes
 - ✓ Eliminate Duplications
 - ✓ Improve Performance



D. Module Review Exercise

Given the Module One Review Exercise of four types of packages:

<u>Package Type</u>	<u>Procurement Strategy</u>
1. ANSI centrifugal pumps	Single source - Goulds key supplier
2. Chilled water centrifugal pumps	Competitive bid - 3 to 4 bidders
3. CS & SS pipe fabrication	Competitively bid
4. Pipe valves & fittings	Single source - McJunkin key supplier

Answer the following questions:

1. Would all four packages have the same number and type of RFQ / P.O. clauses.
2. Would the same milestones need to be tracked for all packages?
3. What considerations should be made when developing an RFQ and P.O. for receiving and issuing activities?



D. Module Review Exercise

Answers

1. No, there would be a different type RFQ & P.O. with less clauses for the bulk packages vs engineered equipment packages as well as Key Supplier vs competitive bid situations. (this is why a sample "shell" is created from master clauses to streamline execution)
2. No, the same number of milestones would not have to be tracked on all packages.
3. The bill of material should be in enough detail to allow the field to receive items against it.



P101 MODULE FOUR

Terms and Conditions

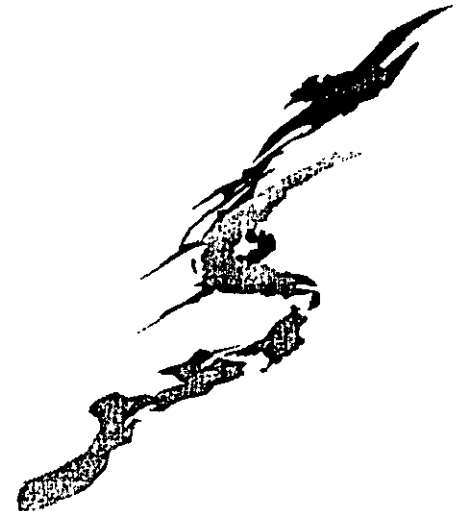
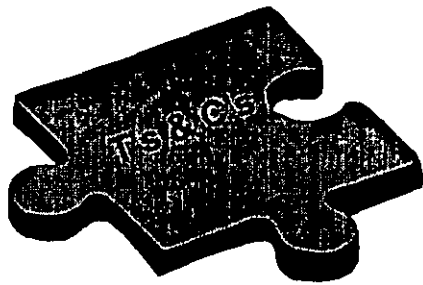

MODULE 4

Terms and Conditions

Purpose: To provide a general overview of purchase order P6 Terms and Conditions.

- A. Terms & Conditions Guidelines
- B. Articles Index
- C. Article Definitions and Interpretations
- D. Module Review Exercise



A. Terms and Conditions Guidelines

- What is the best purchase scenario?
 - A Purchase Order issued without exceptions.
- What steps should we take when the bid arrives with the supplier's Terms & Conditions?
 - First of all, quickly determine if the bid is technically and commercially acceptable.
 - Advise the bidder its bid may be "REJECTED", this gets the attention of the bidder and focuses the bidder in identifying the real areas of concern in our T&C's..
- Exceptions
 - Are there Terms that are more important than others?
(Possibly: read the prime contract)
 - What do you do with the exceptions to the lesser terms?
(PPM confers with Procurement Department Head / Project Manager and determines how and what to negotiate)
 - Do all exceptions need authorization?
(YES)
 - Who authorizes the negotiated exceptions?
(PPM and Procurement Department Head OR the LAW)
 - What happens if the wrong person authorizes exceptions?
(Fluor Daniel may be exposed to more risk)
 - Where and how do you document authorized exceptions?
(In the Purchase Order)



B. Articles Index

- | | | | |
|-----|-----------------------------|-----|-------------------------------|
| 1. | Shipment | 15. | Laws and Regulations |
| 2. | Complete Agreement | 16. | Mechanics' Liens |
| 3. | Title | 17. | Suspension of Performance |
| 4. | Reservation of Rights | 18. | Independent Contractor |
| 5. | Waiver | 19. | Gratuities |
| 6. | Patents | 20. | Confidential Information |
| 7. | Warranty | 21. | Hazardous Materials |
| 8. | Inspection and Expediting | 22. | Validity of Provisions |
| 9. | Indemnity | 23. | Arbitration |
| 10. | Delays | 24. | Right to Offset |
| 11. | Assignment | 25. | Security |
| 12. | Changes | 26. | Insurance |
| 13. | Cancellation for Default | 27. | Safety and Health Regulations |
| 14. | Termination for Convenience | | |

C. Article Definitions & Interpretations

Article 1 Shipment

- ▶ Partial shipments do not divide Seller's obligations.
- ▶ Buyer's count prevails if no packing list is included.
- ▶ Overages may be returned for credit at Seller's expense.

Article 2 Complete Agreement

- ▶ Signing the P.O., acknowledging P.O. acceptance, or commencing performance results in Seller's acceptance of the P.O.
- ▶ The P.O. and the accompanying documents are the entire agreement and have priority over:
 - ✓ Previous Documents (*Proposals, Negotiations, Addenda, Meeting Minutes, etc.*)
 - ✓ Invoices and Acknowledgments
 - ✓ Trade Custom and / or Trade Usage
- ▶ Ambiguities, express conflicts and discrepancies shall be brought to the attention of Fluor Daniel by Supplier.
- ▶ Heading and Numbering are not to be used for interpretation of any provision.

Article 3 Title

- ▶ Seller guarantees that it has sole title to the goods and that title is not subject to any claim by anyone else.
- ▶ If Buyer makes progress payments, title passes once the goods are identified to that P.O.
- ▶ Care, custody and control remains with the Seller until the Buyer takes possession or formally accepts in writing.
- ▶ All shop drawings, patterns, tools or other items made preparatory to production are the Buyer's property.
Consultants will always object because they believe the drawings are their marketing tools.



C. Article Definitions & Interpretations

Article 4 Reservation of Rights

- ▶ The Seller's obligations are still in force and the Buyer's rights of rejection still stand regardless of:
 - ✓ Whether or not inspection has occurred.
 - ✓ Whether payment has occurred.
 - ✓ Whether buyer has knowledge of a non-conformity, regardless of when discovery of a non-conformity occurs.

Article 5 Waiver

- ▶ Just because the Buyer does not insist on performance of any term or condition on a prior occasion does not waive such term, condition, instruction, right or privilege on any occasion thereafter.

Article 6 Patents

- ▶ Seller bears all responsibilities for any patent infringement accusation or final judgment. (including payment of damages against Fluor Daniel and / or client)
- ▶ We must promptly advise Seller in writing of any suits.

Article 7 Warranty

- ▶ The goods will conform to applicable drawings, specifications and other descriptions.
- ▶ The goods will be new, first class, fit and sufficient for all the purposes intended and free from defects.
- ▶ The warranty extends to the Buyer, the Owners and their Customers.
- ▶ Within 12 months after start-up or 18 months after shipment, whichever occurs first, Seller will repair or replace any non-conforming goods or services.
- ▶ All costs of repair are the responsibility of Seller.

Review the Prime Contract to determine if different, and amend our T&C's

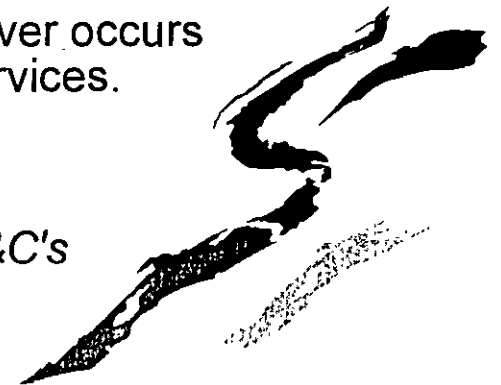

C. Article Definitions & Interpretations

● Article 8 Inspection and Expediting

- ▶ Buyer and Owner reserve the right of inspection and expediting of the Seller and all sub-suppliers of the order.
- ▶ Physical access to all relevant parts of the Seller and sub-supplier's plants is permitted.
- ▶ The Seller must make these terms a requirement for their suppliers.
- ▶ Five (5) calendar days notice in advance of inspection by Buyer required.
- ▶ No goods may be shipped without a final inspection or a written waiver of inspection by the Buyer.
- ▶ At a minimum, order status is to be furnished every 14 days.

Review the Prime Contract for the inspection notice period and order status notice.

● Article 9 Indemnity

- ▶ Seller agrees to indemnify and protect the Buyer and Owner from all injury to persons and damage to property in any way connected with the performance of this P.O. even if injury or damage is caused in part by the Buyer or Owner.
- ▶ However, the Seller is not responsible for any injury or damage caused solely by the negligence of the Buyer or Owner.
- ▶ In providing all indemnity in P.O. Seller agrees it has been paid a specific payment of \$10.

Note: To indemnify means one party assumes an obligation to make the other party whole with respect to the claims of others.

Must review the Prime Contract to ensure wording in this article meets requirements of the prime.



C. Article Definitions & Interpretations

Article 10 Delays

- ▶ Time of delivery is of the essence for the P.O.
- ▶ Seller shall promptly notify Buyer of any actual or anticipated delay and take reasonable steps to avoid such delays.
- ▶ If the delay is caused by acts of God, acts of civil or military authority, war, riots, strikes or similar causes beyond the Seller's reasonable control, then:
 - ✓ The Buyer can terminate the agreement or
 - ✓ The Buyer can extend the date for performance
- ▶ Seller is not entitled to any extra compensation in the event of such a delay.

Must review the Prime Contract to ensure wording in this article meets requirements of the Prime.

Article 11 Assignment

- ▶ Buyer's prior approval is necessary for any assignment of this P.O.
- ▶ The Buyer has the right to assign this P.O. to the Owner or an affiliate of the Buyer.

Article 12 Changes

- ▶ The Buyer has the right to make changes to the specifications and drawings of the P.O.
- ▶ Seller must notify the Buyer of any price or schedule impact within 5 calendar days after Seller's receipt of the notice of change.
Check the Prime Contract for notification period.
- ▶ Seller shall suspend performance of the change unless released in writing by Buyer.
- ▶ While Buyer and Seller are negotiating cost adjustment, unaffected parts the P.O. should proceed.
- ▶ For modifications to be binding upon the Buyer, the agreement or understanding must be in writing.



C. Article Definitions & Interpretations

Article 13 Cancellation for Default

- ▶ Buyer may cancel the P.O. if the seller is judged bankrupt, makes a general assignment for creditors, is insolvent and has a receiver appointed or is in default of any provision or requirement of the P.O.
- ▶ The Buyer may find another means of completing the P.O. and the original Seller is responsible for any additional costs.
- ▶ The Buyer may use money owed the original Seller to satisfy the additional costs.
- ▶ The waiver by the Buyer of any default of Seller does not waive any other requirements or any future default of the Seller.

Article 14 Termination for Convenience

- ▶ Buyer may terminate the order for convenience by written notice at any time.
- ▶ On the date of termination, all work is to be discontinued and all work-in-progress protected.
- ▶ Termination payment shall cover that portion of work performed to date of cancellation (including overheads and profit) and reasonable expenses resulting from the termination.
- ▶ Seller is not entitled to protective profits, overhead, consequential or other termination.
- ▶ All goods must be delivered (with all applicable warranties), assigned or disposed of as directed by Buyer prior to final payment.

In any termination analyze your risk and options as part of a team prior to the termination.

Article 15 Laws and Regulations

- ▶ Seller warrants that all goods and services supplied will comply with applicable laws and regulations.
- ▶ The P.O. will be subject to California Law and Jurisdiction.
Prime Contract will determine any changes to this contract.
- ▶ Seller will be responsible for any costs arising out of Seller's failure to comply with OSHA and Affirmative Action Plans as they relate to the goods.

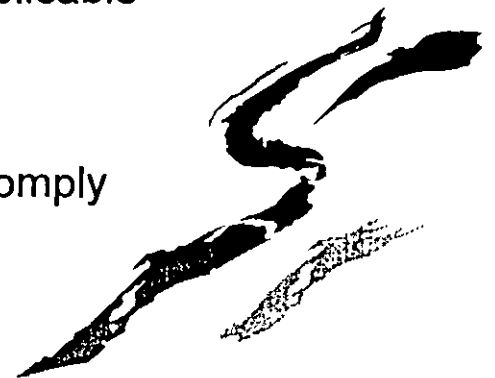

C. Article Definitions & Interpretations

Article 16 Mechanics' Liens

- ▶ Seller will indemnify and defend Buyer and Owner from all liens relating to this P.O. and will keep the premises free of liens.
- ▶ To the extent allowed by law, all lien rights relating to the goods furnished for this P.O. are waived.

Article 17 Suspension of Performance

- ▶ Buyer may at any time suspend all or part of this order for up to 180 consecutive calendar days or 270 total aggregate days.
- ▶ Seller shall promptly and efficiently suspend P.O. performance and properly care for affected goods.
- ▶ Buyer may at any time withdraw the suspension through written notice to the Seller.
- ▶ Seller may pursue justifiable cost adjustments through the Changes provisions, but incidental and consequential damages are not allowed.

Review the Prime Contract for suspension time periods and what Seller is allowed to recover.

Article 18 Independent Contractor

- ▶ Seller is acting as an independent contractor and not as agent or employee of the Buyer.
- ▶ Written authorization by the Buyer is required before any other work can be sub-contracted to others.

Article 19 Gratuities

- ▶ Buyer may terminate this P.O. if it is found that gratuities were offered or given to influence Buyer's award or administration of the P.O. (entertainment, gifts or otherwise).
- ▶ If terminated, Buyer may pursue the same remedies as Buyer may have for breach of the P.O.

Procurement personnel should be aware of our Ethics Policy included in the Procurement Practices.



C. Article Definitions & Interpretations

Article 20 Confidential Information

- ▶ Seller and sub-suppliers will not disclose any document designated as confidential to any third party or use it for any purpose other than performance of the P.O.
- ▶ Seller shall not publicize the existence or scope of the P.O. without Buyer's consent.

Article 21 Hazardous Materials

- ▶ Seller must advise Buyer if any goods are furnished which are subject to hazardous / toxic rules and regulations.
- ▶ Appropriate shipping and handling instructions for such hazardous / toxic materials must be provided to Buyer.
- ▶ A specified certification must appear on the Bill of Lading for any hazardous materials.

Article 22 Validity of Provisions

- ▶ The provisions in the whole Purchase Order are not invalid because one provision or part is unenforceable.

Article 23 Arbitration

- ▶ If Buyer is required to arbitrate a dispute with a third party, Seller agrees to join in the arbitration and to be bound by the resulting judgment.

Note: The hearing and determination of a case in controversy by a person chosen by the parties or appointed under statutory authority.

This article commits the Seller to support Fluor Daniel in any arbitration Fluor Daniel may be involved in. It does not mean that Seller and Fluor Daniel will resolve their disputes through arbitration.



C. Article Definitions & Interpretation

Article 24 Right to Offset

- ▶ Any amounts which the Seller owes the Buyer under this P.O. may be deducted to pay any other debt Seller owes Buyer or Owner.

Article 25 Security

- ▶ If the Buyer makes any advance payment or progress payment, the Seller may be required to execute a Security Agreement and Financing Statement. This gives the Buyer a priority to the goods over any of Seller's other creditors.

Article 26 Insurance

- ▶ Certificate of Insurance required 30 days prior to commencing work.
 - ✓ Workman's compensation - \$100,000 / occurrence - minimum
 - ✓ Comprehensive General Liability - \$1,000,000 / occurrence, includes bodily injury, property damage, including death
 - ✓ Automobile - \$1,000,000 / occurrence

This article is applicable when services are performed at site.

Review the Prime Contract for insurance changes.

Article 27 Safety and Health Regulations

- ▶ Seller abides by and enforces our project safety requirements.
- ▶ Work area to be kept clean.
- ▶ Fluor Daniel or Owner has right to remove person(s) violating safety rules & regulations.

This article is applicable when services are performed at site.



D. Module Review Exercise

Module 6 will go into further detail about bid receipt, negotiations and award. Additional modules, later in the course, are all capable of having a Terms & Conditions issue arise.

For this exercise, let's say the prime contract requires a longer warranty period than that of our company standard stated in article number 7.

1. How do we emphasize this to suppliers?
2. What if there is a related cost?
3. What if the Seller will not agree to a Fluor Daniel term which is also in the Prime Contract?
4. What if the supplier can honor required warranty on 5 pumps but not the other 5 pumps?



D. Module Review Exercise

Answers

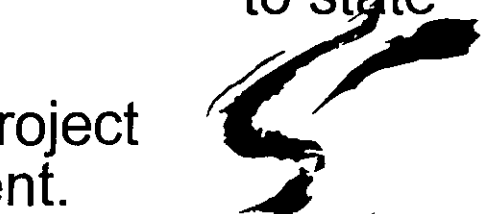
1. Special clauses within the Sample Purchase Order and Purchase Order should address the following:
 - ✓ Sample P.O. - state warranty required and that this supersedes article 7 of Terms and Conditions.
 - ✓ P.O. - state agreed warranty period achieved including expiration date.
 2. Exhaust all efforts to negotiate additional charge for extended warranty. However, if unsuccessful, itemize cost in order so not to confuse total material cost.
 3. If the prime contract extended warranty cannot be achieved then the Project Director and Client must agree to any less stringent warranty requirement. The P.O. should then be amended to state agreed warranty.
 4. Again, negotiate the best warranty possible, obtain Project Director and Client approval, and document agreement.
- 

P101 MODULE FIVE

Request for Quotation

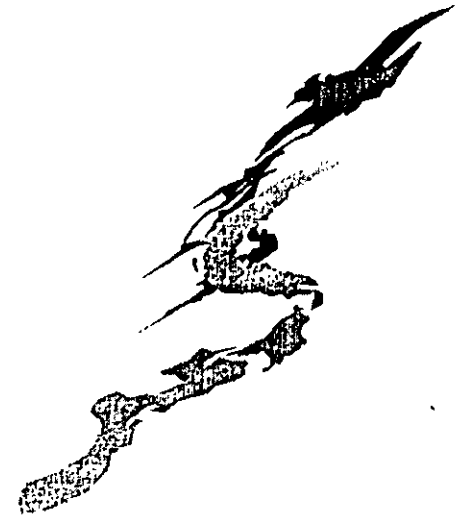
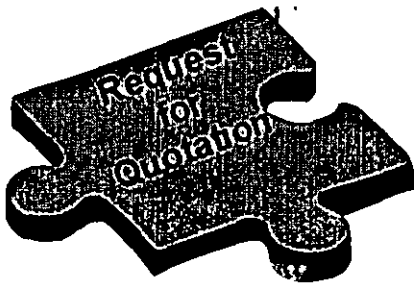

MODULE 5

Request for Quotation

Purpose: To provide guidance in the preparation, issuance and execution of a Request For Quotation.

- A. Request for Quotation
- B. Preparing the Bid Document
- C. Bid Receipt Preparation
- D. Module Review Exercise



A. Request for Quotation

What is it?

A Request For Quotation is a formal approach to obtaining a price from selected bidders for a particular commodity that will be purchased.

Why do we do it?

To obtain materials ethically and consistently for a fair price and to ensure all bidders receive the same information pertaining to the bid package.

Who creates a Requisition?

During the design and construction phases, engineers create the requisitions.

How does a Requisition get to Procurement?

It must have a routing sheet complete with project approval signatures.

What does Procurement do with a Requisition?

Prepare for bid by selecting and contacting the bidders. Confirm bid close date and address. Decide how to bid the package (i.e. telephone or formal). Assemble the commercial verbiage (i.e. Sample P.O.). Issue to bidders.

Why do we have a Sample P.O. and a P.O. document?

A Sample P.O. is generated during the bidding cycle and sent with the RFQ so bidders can see Purchase Order commercial criteria. At time of award the Sample P.O. is transferred into the P.O. with little effort.

What is a Pre-Bid Meeting?

One meeting with all bidders held shortly after bid issue to focus on scope and requirements as well as to discuss any and all clarifications the bidders may have.



B. Preparing the Bid Document

- ✓ **Request For Quotation:** a document that introduces the package to the bidders and instructs them how to qualify for further consideration.
 - ★ RFQ Clauses and Bid Requirements

- ✓ **Sample Purchase Order:** a document that contains all commercial topics which govern during execution of the purchase order.
 - ★ Purchase Order Clauses and Execution Requirements

- ✓ **Bill of Material:** a document that lists scope of supply which bidders post pricing on and return for consideration.
 - ★ Quantity / Description / Catalog Number

- ✓ **Technical Attachments**
 - ★ Vendor Data Requirements / Specifications / Surveillance Check List / Engineering Data Sheets / Drawings

- ✓ **Commercial Attachments**
 - ★ P6 Form - Terms & Conditions
 - ★ P10 Form - Hazardous & Toxic Substances
 - ★ P11 Form - Seller's Representation & Certifications



B. Preparing the Bid Document

Master Purchase Order Clauses

- *Governing T&C's
- *Definitions
- *Communications
- *Technical Attachments
- *Commercial Notes
- *Invoice Information
- *Shipping Instructions
- *Schedule
- *Spare Parts
- *Acceptance
- Equal Opportunity
- Field Service
- Cancellation
- U.S. Origin
- *Surveillance

* Denotes usage in Sample P.O.
#GMS-A-001

Master RFQ Clauses

- *Governing Terms and Conditions
- *Statement of Compliance
- *Communications
- *Commercial Requirements
- *Alternate Quotations
- Reservation of Right

* Denotes usage in RFQ
#GMS-A-001

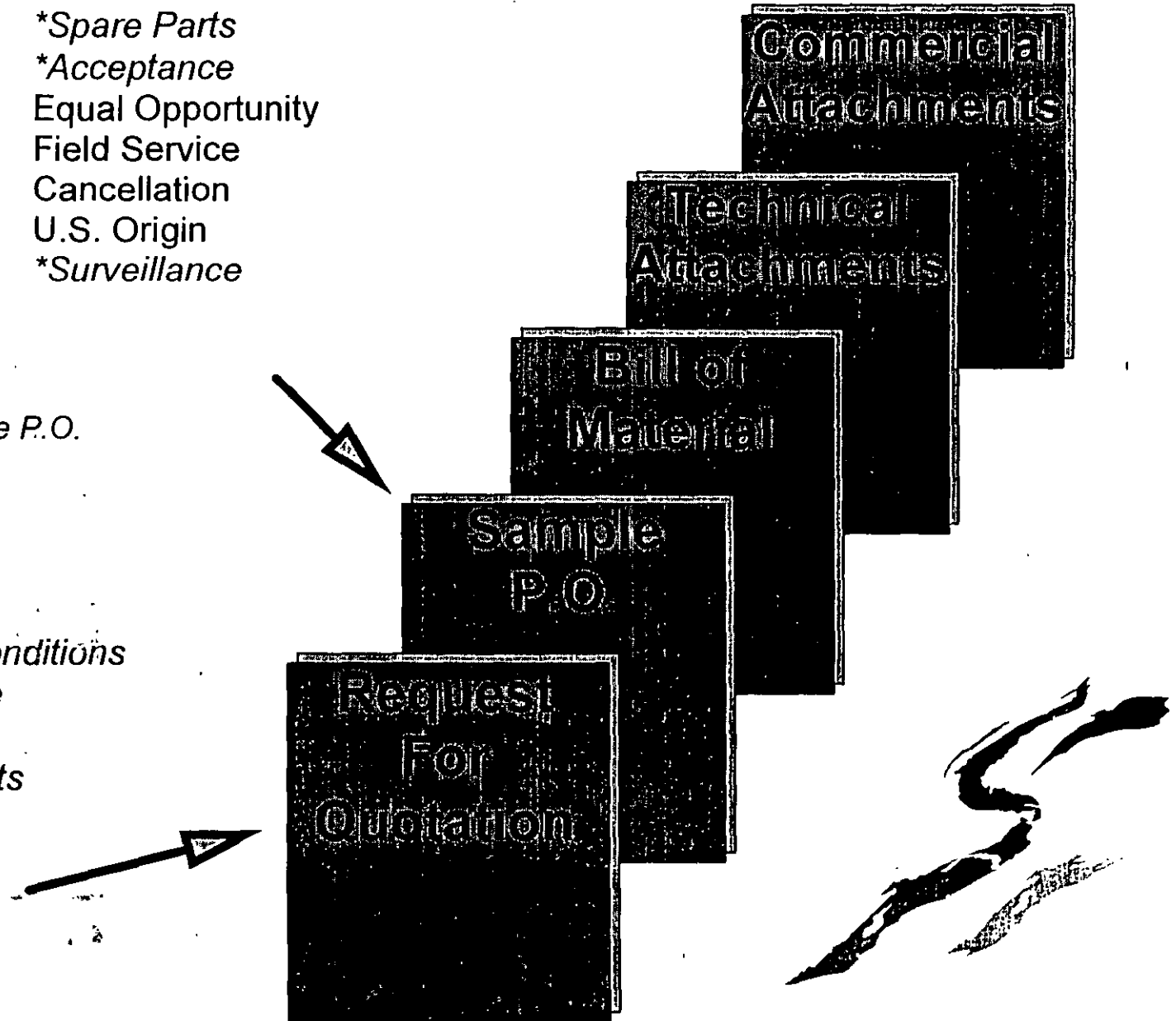

B. Preparing the Bid Document

Sample Purchase Order Clauses

- Governing Terms and Conditions
- Definitions
 - Owner
 - Buyer
 - Seller
- Communications
 - Commercial
 - Technical
 - TDC
 - Invoice
- Technical Attachments
 - Specifications
 - Data Sheets
 - Drawings
- Commercial Notes
 - Pricing
- Invoice Information
 - Number of Invoice Copies Required
 - Terms of Payment
 - Order Completion Retention Provision
 - Freight Terms
 - Taxes
- Shipping Instructions
 - To
 - Via
 - Weight and Dimensions
 - Packing and Marking
- Schedule
- Spare Parts
 - Quotation For 1 yr. Operations
- Acceptance
 - Sign and Return
- Equal Opportunity
 - Statement
- Field Service
 - Mfg. Service, Start-up Assist.
- Cancellation
 - Finalize Prior to Award
- U.S. Origin
 - Mfg. in USA
- Surveillance
 - Level and Plan

Request For Quotation Clauses

- Governing Terms and Conditions
- Statement of Compliance
 - Bid Exactly per Specification
 - Bid per Spec. with Exceptions
- Communications
 - Procurement
- Commercial Requirements
 - Bid Close Date
 - Number of Bids
- Commercial Requirements (Continued)
 - Instructions
 - Are Bids Sealed?
- Alternate Quotation
 - Base Bid Required Per Specification with Alternate Bid
- Reservation of Right
 - Reserve the Right to Split and Combine



C. Prepare for Bid Receipt

► Expedite Bids

- First contact with suppliers shortly after RFQ issuance.
 - ✓ Confirm receipt of bid.
 - ✓ Confirm bid close date.
 - ✓ Facilitate clarifications.
- Second contact with suppliers up to one week prior to bid due date.
 - ✓ Confirm bid close date.
 - ✓ Facilitate clarifications with engineering. Prefer clarifications to be written.

► Bid Extensions

- If steps listed above are taken prior to RFQ issuance, extensions should not be needed.
- As a norm, are Not granted.
- Are granted if all or a majority of the bidders request them.
NOTE: Refer to procurement practices and project procedure for specific project policy.

► RFQ Addendum

- A written method of advising bidders of a scope change that will affect the bidding process and final product.

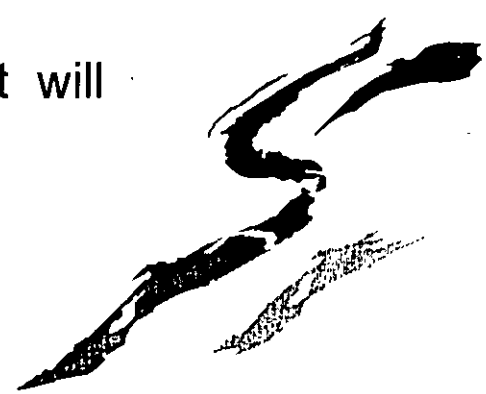

D. Module Review Exercise

RFQ #GMS-A-001 for 10 chilled water pumps P-101 through P-110 has just been received in procurement. The procurement strategy for this package is to competitively bid to:

Chump's Pumps
Pump and Circumstance, Inc.
H.R. Pumps & Stuff

Answer the following questions:

1. Prior to formally receiving the RFQ in Procurement and issuing it to the bidders what constitutes a complete RFQ from engineering?
2. Why should you contact each bidder prior to package issuance?
3. When should you expedite bid receipt?



D. Module Review Exercise

Answers

1. A complete RFQ includes:
 - An engineering transmittal cover sheet complete with all approving signatures.
 - A list of the specifications and data sheets.
 - A bill of material listing P-101 through P-110.
 - Engineering attachments including specs / dwgs / vendor data requirements / inspection check list

2. Make contacts to bidders to:
 - Confirm they are interested in bidding this RFQ.
 - Confirm address and bid close date.
 - Address any special features about the package and / or project.

3. Expedite bids:
 - Within one week after RFQ issuance.
 - One week prior to bid due.



P101 MODULE SIX

Bid Analysis and Purchase Order Award

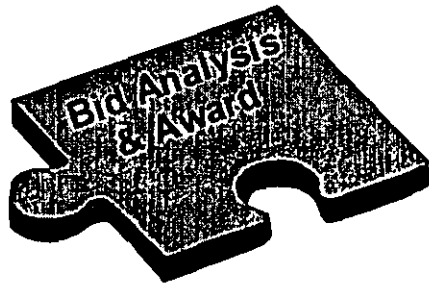

MODULE 6

Bid Analysis and P.O. Award

Purpose: To provide an overview of the bid analysis process with an emphasis on techniques to select the best source of supply.

- A. Bid Summary
- B. Bid Analysis / Evaluation
- C. Recommendation Through Award
- D. Module Review Exercise



A. Bid Summary

What is it?

- A document used to summarize technical and commercial information from bidder proposals.

What happens when the bids arrive?

- We perform an initial analysis to determine major errors or omissions and fax bidders for this information.
- Procurement then provides engineering with a copy of the bid and the posting of information begins:

Procurement

- ✓ Schedule
- ✓ Commercial Terms
- ✓ Supplier Performance
- ✓ Logistics
- ✓ Supplier Added Value
- ✓ Bid Clarifications
- ✓ Control Bid Analysis

Engineering

- ✓ Compliance with Specifications
- ✓ Reconcile Technical Deviations
- ✓ Technical Value Awareness
- ✓ Liaison Between Engineering Disciplines
- ✓ Technical Qualification
- ✓ Quantities
- ✓ Supplier Added Value
- ✓ Technical Bid Clarification
- ✓ Alternates



B. Bid Analysis / Evaluation

Listed below is a menu of key items which may be reviewed as part of a bid analysis.

Cost Factors

- Material Cost
- Payment Terms
- Price Escalation
- Inland Freight
- Ocean Freight
- Overseas Inland Freight to Jobsite
- Air Freight
- Extended Warranty
- Document Charges
- Export Packaging Charges
- Customs Clearance
- Spare Part Discounts
- Service Representative Cost
- Drawing Approval Cost
- Progress Payments
- Cost of Cash
- Engineering Data Cost
- Equipment Tag Cost
- Cutting Charges
- Drum / Reel / Cylinder Deposits
- Reel Cover Charge
- Surplus / Restocking
- Import Duties
- Storage Cost
- Insurance Cost
- Expediting
- Inspection
- Taxes

Additional Factors

- Supplier Evaluation Rating
- Incoterms
- Ship Point
- Estimated Shipping Weight
- Estimated Shipping Volume
- Required Ship Date
- Promised Ship Date
- Exceptions to Specifications
- Exceptions to T&C's
- Drawing / Data Promise Dates
- Project Schedule
- Local Service
- Quotation Validity
- Accept P.O. for Partial Quantity
- Quotation "All or None"
- Minimum Order Quantity
- Exchange Rates
- Fabrication in Transit
- Freight Equalization
- Client Directive



B. Bid Analysis / Evaluation

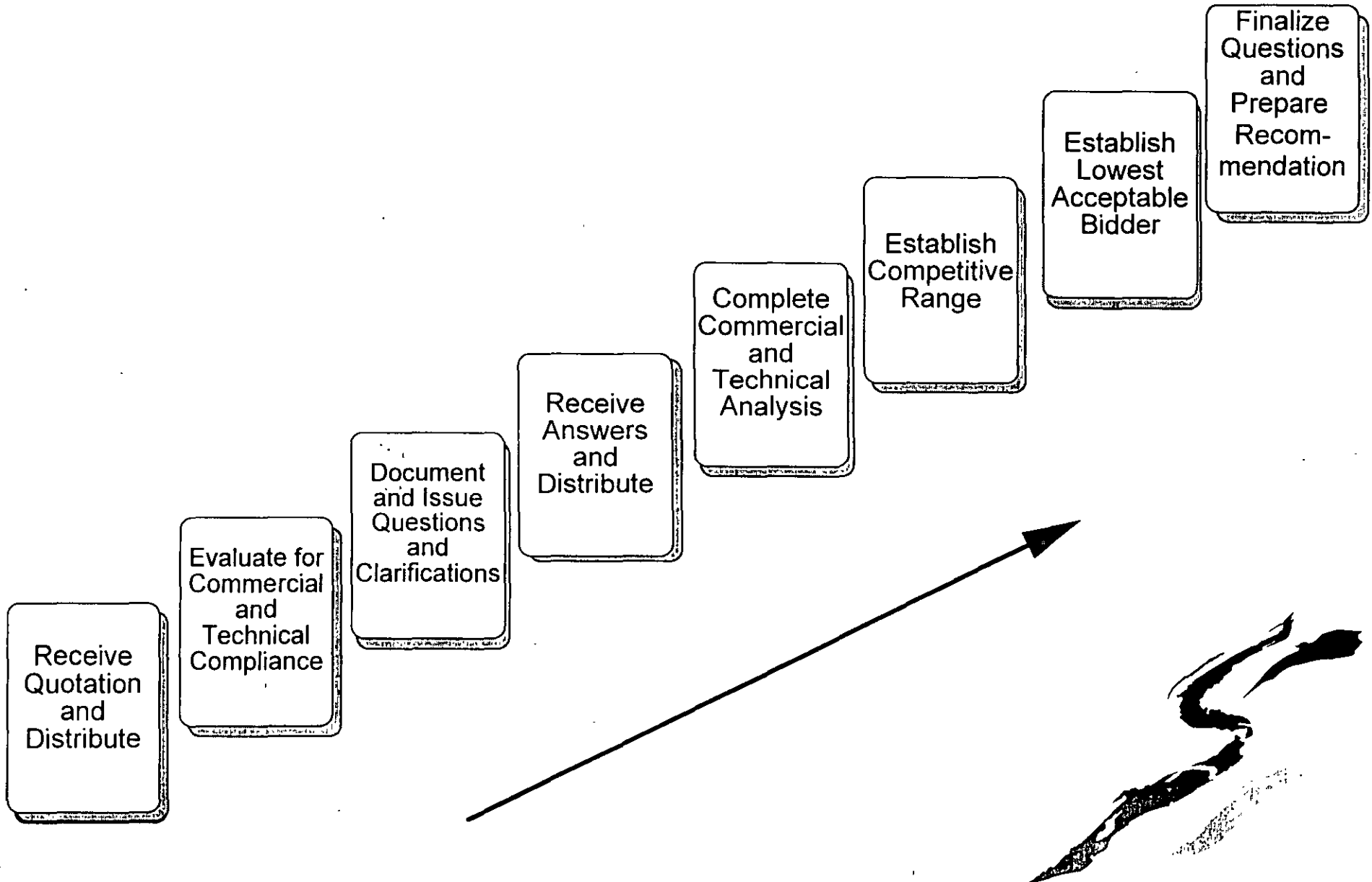

C. Recommendation Through Award

- Recommendation
 - ✓ Procurement
 - ✓ Engineering
 - ✓ Joint
- Pre Award Meetings
 - ✓ Strategy
 - ✓ Agenda
 - ✓ Participants
 - ✓ Specific to Bidder
 - ✓ Take Good Meeting Notes
 - ✓ Action Item Responsibility
 - ✓ Agree on Path Forward
 - ✓ Establish Closure Date
- Obtain Approval to Proceed
 - ✓ Project
 - ✓ Client
 - ✓ Other
- Award Purchase Order
 - ✓ Advise Successful Bidder
 - ✓ Issue Purchase Order
 - ✓ Issue Regret Letters to Unsuccessful Bidders
 - ✓ Distribute and File



D. Module Review Exercise

In module five we developed an RFQ #GMS-A-001 for 10 pumps (P101 through P110) and issued bids to three suppliers. The bids have been received and we are now ready to start the "Bid / Analysis" process.

The RFQ and Sample Purchase Order call for the pumps to be furnished, fabricated, tested, inspected and delivered in accordance with the specifications and data sheets.

The project is on a fast track schedule and all ten pumps are required at site no later than 13 weeks from tomorrow. You are planning on completing the bid analysis and personally rushing the package through the approval process today. You will be issuing the purchase order to the approved bidder tomorrow.

It should also be noted that vendor prints are required for approval four (4) weeks After Receipt of Order and a two (2) week turnaround time is estimated by engineering. The purchase of material, as well as release for fabrication shall only be upon approval/review of vendor prints.



D. Module Review Exercise

Your tasks for this exercise are:

1. Review information and make a recommendation for award ensuring that all technical and commercial issues have been resolved to arrive at the best balanced choice.
2. Once the source of supply is selected, list some negotiation techniques that apply to further project savings or added value with this bidder.

Things to consider during the bid analysis process:

1. Item Spread on next page
2. Budget \$85,000
3. RAS 13 weeks
4. Engineering to return drawings 2 weeks after receipt of drawings
5. In order to meet schedule, each bidder must rely on an overseas resource for four (4) pumps (P105 - P108). The overseas resource will ship these pumps to a bidder who will mount the motor on each pump base and then ship the pump assembly to the jobsite.
6. There is an incentive / penalty clause in the prime contract which relates to delivery. Having agreed to RAS dates with the client, any schedules that can be compressed by a week or more means a \$2,500 bonus to FD. On the other hand, a penalty of \$2,500 can be charged to FD for each week of slippage.
7. The client requires an 18 months from purchase and 12 months from start-up warranty for all equipment.
8. Any extra inspection visits can be estimated at approximately \$718 per visit.
9. Commercial Information:

	Chump's Pumps	Pump & Circumstance	H.R. Pumps & Stuff
Performance Ratings	80%	91.3%	70%
Freight Costs	\$3,500.00	\$0.00	\$2,208.00
Warranty	18 / 12	12	18 / 12

10 All three bidders are technically acceptable and the client prefers Pump & Circumstance. Engineering recommends Pump & Circumstance based on lowest bid.



D. Module Review Exercise

Engineering Analysis & Item Spread

Item No.	Qty.	Description	Chump's Pumps		Pump & Circumstance		H.R. Pumps & Stuff	
			Unit Price	Extension	Unit Price	Extension	Unit Price	Extension
1	1	Pump P101	\$10,057.00	\$12,277.00	\$5,779.00	\$7,468.00	\$4,625.00	\$6,445.00
		Motor	\$2,220.00		\$1,689.00		\$1,820.00	
2	1	Pump P102	\$8,216.00	\$10,436.00	\$5,779.00	\$7,468.00	\$4,625.00	\$6,445.00
		Motor	\$2,220.00		\$1,689.00		\$1,820.00	
3	1	Pump P103	\$8,216.00	\$10,436.00	\$5,779.00	\$7,468.00	\$4,625.00	\$6,445.00
		Motor	\$2,220.00		\$1,689.00		\$1,820.00	
4	1	Pump P104	\$8,216.00	\$10,436.00	\$5,779.00	\$7,468.00	\$4,625.00	\$6,445.00
		Motor	\$2,220.00		\$1,689.00		\$1,820.00	
5	1	Pump P105	\$8,216.00	\$10,436.00	\$5,779.00	\$7,468.00	\$4,625.00	\$6,445.00
		Motor	\$2,220.00		\$1,689.00		\$1,820.00	
6	1	Pump P106	\$5,801.00	\$9,921.00	\$4,347.00	\$7,873.00	\$4,550.00	\$9,240.00
		Motor	\$4,120.00		\$3,526.00		\$4,690.00	
7	1	Pump P107	\$4,628.00	\$8,748.00	\$4,347.00	\$7,873.00	\$4,550.00	\$9,240.00
		Motor	\$4,120.00		\$3,526.00		\$4,690.00	
8	1	Pump P108	\$4,628.00	\$8,748.00	\$4,347.00	\$7,873.00	\$4,550.00	\$9,240.00
		Motor	\$4,120.00		\$3,526.00		\$4,690.00	
9	1	Pump P109	\$4,628.00	\$8,748.00	\$4,347.00	\$7,873.00	\$4,550.00	\$9,240.00
		Motor	\$4,120.00		\$3,526.00		\$4,690.00	
10	1	Pump P110	\$4,628.00	\$8,748.00	\$4,347.00	\$7,873.00	\$4,550.00	\$9,240.00
		Motor	\$4,120.00		\$3,526.00		\$4,690.00	
Engn / Insp. / Documentation				\$0.00		\$0.00		\$1,125.00
Witness Testing				\$0.00		\$1,621.00		\$1,860.00
Total Price Items Quoted				\$98,934.00		\$78,326.00		\$81,410.00
Delivery - Draw ings (ARO)				3 w ks		4 w ks		1 w k
Delivery - Equipment (ARAD)				10-12 w ks		8 w ks		6 - 8 w ks
(Est) Jobsite Arrival				1 w k		1 w k		1 w k



D. Module Review Exercise

Suggested Answers

	Chump's Pumps	Pump & Circumstance	H.R. Pumps & Stuff
Total Price Items Quoted	\$98,934.00	\$78,326.00	\$81,410.00
Freight Costs	\$3,500.00	\$0.00	\$2,208.00
Terms of Payment	\$0.00	\$0.00	(\$407.05)
Warranty	\$0.00	\$500.00	\$0.00
RAS incentives/penalties (13 weeks)	\$12,500.00	\$5,000.00	(\$2,500.00)
Total Cost	\$114,934.00	\$83,826.00	\$80,710.95

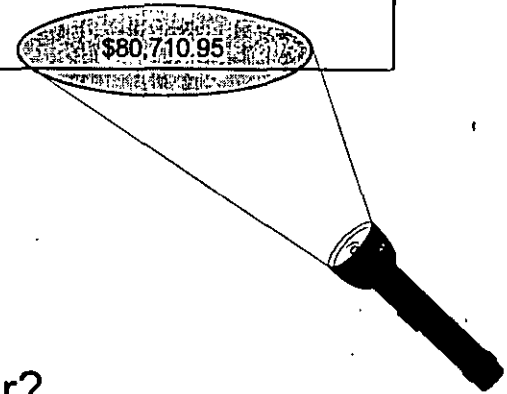

Strategies / Negotiation

Performance Incentives for Supplier?

Traffic?

Surveillance?

Payment Terms?



P101 MODULE SEVEN

Purchase Order Administration



MODULE 7

Purchase Order Administration

Purpose: To provide an overview of the buyer's responsibilities for executing a purchase order

- A. Change Orders
- B. Material Safety Data Sheets
- C. Handling Invoices
- D. Surplus Material - Procurement's Responsibility
- E. Backcharges
- F. Measurement of Supplier Performance
- G. File Set Up, Maintenance, Close-out & Retention
- H. Module Review Exercise



A. Change Orders

A change order is normally required to a Purchase Order when one of the following circumstances occur:

- ▶ Any changes in price
- ▶ Revising or changing commercial terms
- ▶ Correcting a pricing error
- ▶ Revising a tag number
- ▶ Whenever added or decreased expenditures are required (i.e. increase or decrease of quantity of material)
- ▶ Any technical change (i.e. change in specification)
- ▶ Any changes in schedule dates (i.e. shipping date)
- ▶ Whenever part or all of an order is canceled
- ▶ To cancel and reissue a Purchase Order
- ▶ Whenever Surpluses are accepted

Note: Refer to Fluor Daniel Procurement Practice pages 4 - 16, for examples of how to for the above conditions.

000 400-1000,
write change orders



B. Material Safety Data Sheets

Successful bidders on all purchases destined for U.S. jobsites must complete a U.S. Department of Labor form OSHA-20, Material Safety Data Sheet (MSDS) or equivalent. Otherwise they must submit a disclaimer statement certifying that the material is not a hazardous or toxic substance as defined by federal regulation.

The buyer is responsible for distributing completed MSDS, or equivalent, and executed disclaimer statements as follows:

- A. Copy for the Purchase Order file
- B. Original and one copy to the field construction manager at the jobsite



C. Handling Invoices

Buyers may be asked to assist in the processing of invoices. If an invoice is addressed to a buyer, forward it to the appropriate Accounts Payable group. Assistance may be required for the following reasons:

- ▶ Verification of a progress payment application (i.e. Have submittal drawings been received. The applicable engineer and document control should verify all receipt of drawings.)
- ▶ If there is a discrepancy between what is stated in the Purchase Order and what is stated in the seller's invoice (i.e. payment terms).
- ▶ Verification for final payment. (i.e. has all documentation been received; are all materials / equipment received at site; is all change order work complete; are backcharges, deficiencies, surplus material problems resolved?)

Note: The decision to issue a change order will be in accordance with the project procurement procedure.

- ▶ A copy of all documentation justifying any decisions by the buyer must be maintained in the Purchase Order file.



D. Surplus Material - Procurement's Responsibility

Project management must determine what is surplus material. Ensure that you receive an approved documented inventory list.

- What is procurement's role in disposing of surplus material?
Determine who and at what price the material will be liquidated / returned.
- Five common ways to dispose of surplus material:
 1. Retain and hand over to client (cost plus vs lump sum).
 2. Offer to other Fluor Daniel projects.
 3. Return to Seller (stress importance of buy back clauses, return authorization numbers, etc.)
 4. Sell to general public, surplus dealers, employees.
 5. Donate to charitable causes.
- Remember that if no buy back clauses have been included, restocking charges are subject to your best negotiations.
- If it is a project caused surplus due to over ordering, a change order should be issued to finalize the value of the purchase. This could mean the issuance of a credit if the Purchase Order has been closed.
- If it is a Seller caused surplus, the Seller must take the surplus back with no restocking charge including all applicable freight charges (in and out).



E. Backcharges

What are backcharges?

Webster defines it as... undefined. The term is unique to our industry. It is more commonly called "claims". Our practices define backcharges as a means for recovering cost from sellers, freight carriers and / or insurance carriers that result when equipment or material arrive in a defective condition, or is unsuitable due to seller error or transportation damage.

What is Procurement's role in the handling of backcharges?

- Procurement has the lead role in handling claims, from notification of the proper party, to collection of documentation, to resolution of the claim.

Procedure:

1. Immediately notify the seller and the carrier of any visual damages or defects. Take photographs or video if at all possible.
2. Discuss with the project the timing / technical resources required for corrective action. Offer the responsible party the opportunity to correct the problem but define the time frame for the fix.
3. Obtain written documentation on the agreed upon solution.
4. If Fluor Daniel is to make the repair, ensure that you have accurate time sheets and material invoices to document your claim. No profit is to be added to Fluor Daniel's work but applicable burdens / indirects are appropriate.
5. Don't let it drag out too long as time hazes everything!

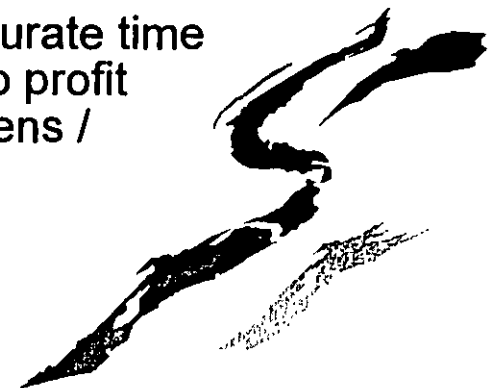

F. Measurement of Supplier Performance

Why evaluate suppliers?

1. To collect performance data
2. Give us a performance check
3. Provide supplier with ways to improve
4. Show clients we deal with top performers
5. Aid in selection of bidders lists
6. Justify award recommendations

Procedure: Supplier evaluations shall be done on ALL purchase orders with values of \$50,000 or more

Working Tips

1. Initiate the form as part of the work process when the order is issued. By doing this the engineer should be filling out the form during the life of the order as opposed to when the job is near completion. If this process is put off until the end of the job, the engineer may be gone or fail to remember the specifics.
2. Hold a brief meeting if it is a new project with new personnel. Build value for the data by showing them where their feedback goes. Get project management involved for the needed support to make the program a success.



G. File Set Up, Maintenance, Close-Out and Retention

File set up:

Although not required for every order, file tabs are recommended for all orders which are custom orders or subject to change.

Maintenance of files is also handled easily when the tabs are used because filing is per the tab title. Ensure that filing is done chronologically to ease in data collection for claim resolution or audit response.

- Close-out of files:

Utilizing the checklist found in Practices will ensure close-out of purchase orders are handled effectively.



H. Module Review Exercise

True or False

- A Change Order should be written for a supplier name change.
- A buyer should process invoices instead of Accounting.
- It is not necessary to contact the seller on backcharge issues.
- The buyer should wait until the end of the project to process backcharges.
- Supplier evaluations should be done for orders greater than or equal to \$50,000.00.



H. Module Review Exercise

Answers

True or False

T A Change Order should be written for a supplier name change.

F A buyer should process invoices instead of Accounting.

F It is not necessary to contact the seller on backcharge issues.

F The buyer should wait until the end of the project to process backcharges.

T Supplier evaluations should be done for orders greater than or equal to \$50,000.00.



P101 MODULE EIGHT

Expediting

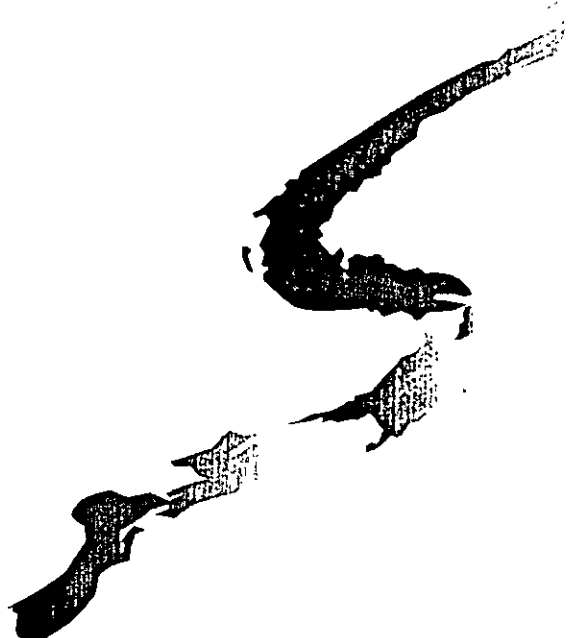
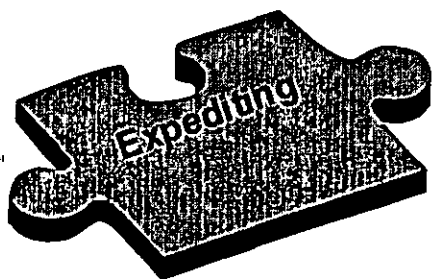

MODULE 8

Expediting

Purpose: To provide a general understanding of basic expediting practices with an emphasis on:

- A. Expediting
- B. Levels
- C. Summary Level Work Process Flow Chart
- D. Work Process Definitions
- E. Execution
- F. Module Review Exercise



A. Expediting

What is it?

Expediting is a process by which we monitor the status of schedule dates from the seller as promised in the Purchase Order and exert all efforts to support that schedule.

Why expedite?

To ensure that all material requirements are received at the jobsite on time and in good condition.

What are the key elements of effective expediting?

- Persistence
- Well written orders
- Communication
- Understand the Supplier's order entry process
- Order entry & manufacturing process
- Read and understand the order
- Maintain good notes & records
- Teamwork
- Reporting

Do all orders get the same amount of attention?

No, see section B. Levels



B. Levels of Expediting

	A - Major Equipment Systems	B - Equipment	C - Instruments	D - Bulk Material
Criteria	Long Lead Equipment complexity Equipment criticality to Plant Process & Start Up Schedule Supplier experience Sub-supplier involvement	ETA within 4 weeks	ETA over 4 weeks Less critical	Stock to 2 week deliveries
Expediting Required	Phone Physical	Phone Physical (if required)	Phone	Phone
Plan	Weekly phone / fax Monitor progress against supplier production program Expedite sub-suppliers Coordinate physical visits Verify completion of material & fabrication milestones Authorize progress payments for milestone completion May require pro-active acceleration discussions	Bi-weekly phone / fax Monitor progress against supplier production program Expedite sub-suppliers Coordinate physical visits Verify completion of material & fabrication milestones Authorize progress payments for milestone completion	Monthly phone / fax	Phone / fax at initial order Phone / fax by exception

Do levels of expediting change for particular orders over time?

Yes - Typically "A" levels turn into "B" levels with the progression of the order. Contacts are changed from weekly to bi-weekly.



3. Summary Level Work Process

This summary level chart introduces key steps of the Expediting work process for this overview. Detailed flow charts exist in Folio to assist in daily activities.

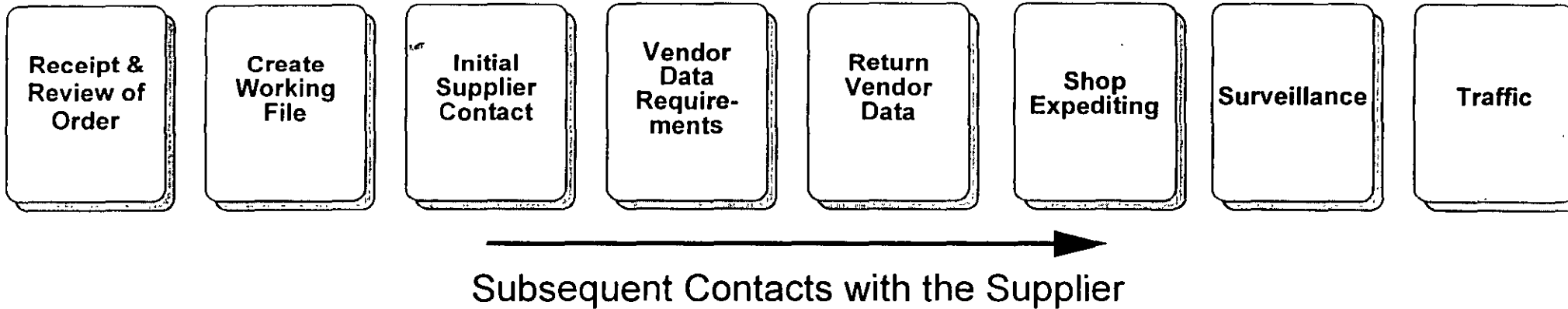

D. Work Process Definitions

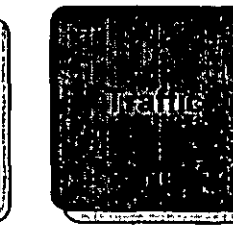
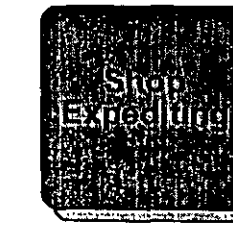
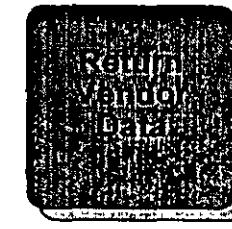

- Receive and Review Purchase Order
 - ✓ Receive: each order should include
 - ▶ Purchase Order
 - ▶ Bill of Material (BOM)
 - ▶ Vendor Data Requirement Sheet (VDR)
 - ▶ Inspection Check List
 - ✓ Review:
 - ▶ Schedule
 - ▶ Drawing Submittals Required
 - ▶ Authorization of Material Purchase
 - ▶ ARO After Receipt of Order
 - ▶ ARD After Return of Drawings
 - ▶ Payment Terms vs. Milestone Activity
 - ▶ Special Handling
 - ▶ Special Storage
 - ▶ Logistics
 - ▶ Surveillance



D. Work Process Definitions

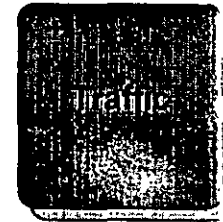
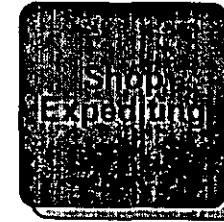
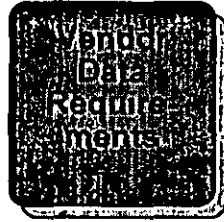
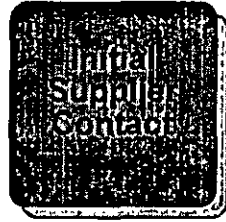
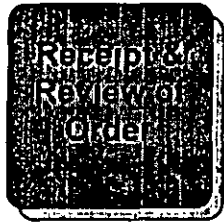

- Create Working File
 - ✓ Purchase Orders
 - ✓ Change Orders
 - ✓ Correspondence
 - ✓ Document Transmittals
 - ✓ Reports
 - ▶ Shop Expediting
 - ▶ Surveillance
 - ✓ Shipping Notice
 - ✓ Field Receiving Reports (FRR)
 - ✓ Overage, Shortage and Damage Reports (OS&D)

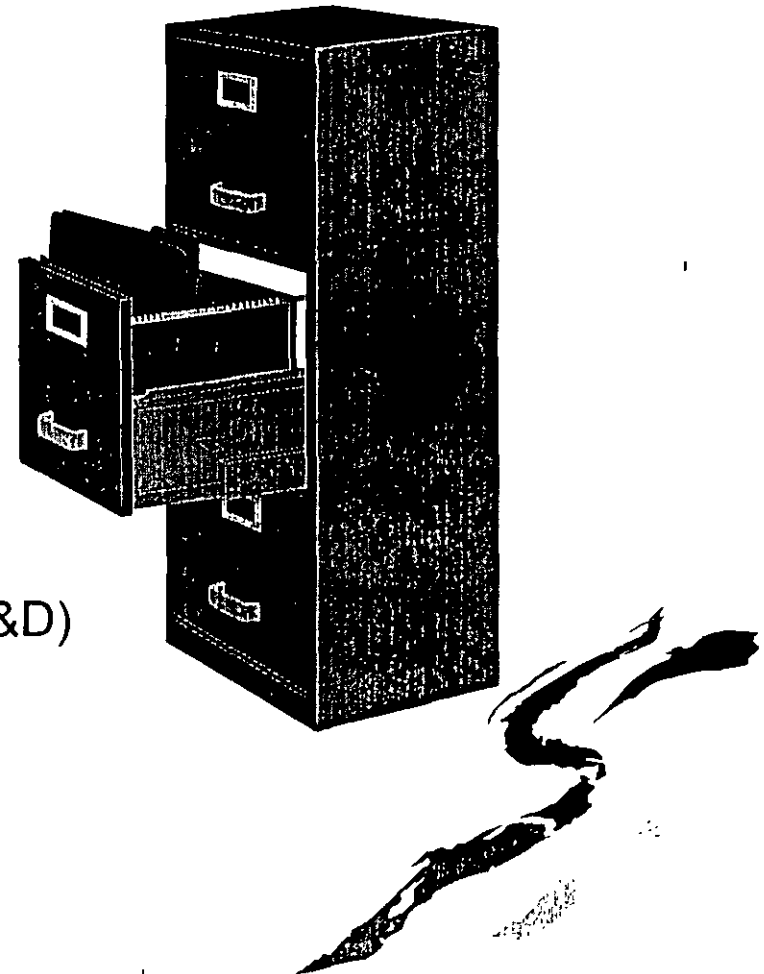

D. Work Process Definitions

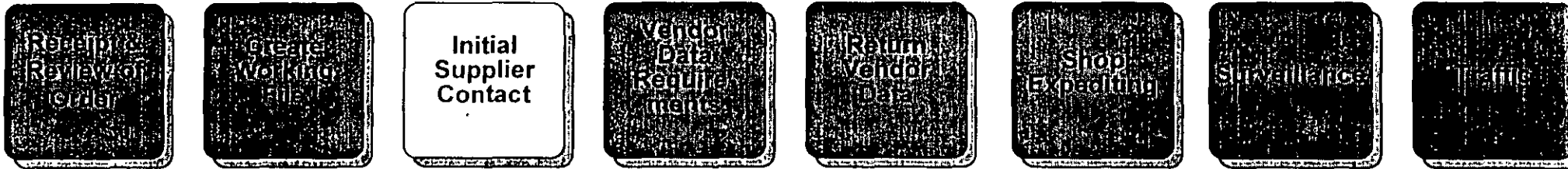

● Initial Supplier Contact

✓ Introduction

- ▶ Exchange Chain of Commands
 - Engineering
 - Customer service
 - Production Supervisor
 - Project Manager

✓ Order Entry

- ▶ Review Purchase Order Requirements
- ▶ Confirm Supplier receipt of P.O.
- ▶ Request status of signed Purchase Acknowledgment
- ▶ Confirm that Order Entry is complete at Supplier facility

✓ Important Facts to Discuss with Supplier

- ▶ Determine engineering & fabrication facility location
 - Shop capacity
- ▶ Confirm surveillance requirements
- ▶ Confirm labor posture
 - Contract expiration
 - Potential strikes



D. Work Process Definitions

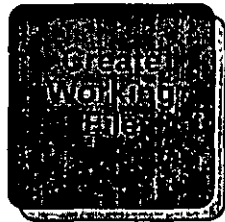

- Initial Supplier Contact (**CONTINUED**)

- ✓ Important Facts to Discuss with Supplier (continued)

- ▶ Determine material status

- Stock items

- Buy out items

- Long lead items

- ▶ Establish regular reporting time frames and criteria

- Status of material... if not in stock, date due in

- Status of manufacturing... milestone activities with start & end dates

- Inspection schedule... number of inspections and tentative schedule

- Special packaging... what is required and how much time to execute

- Ship schedule... reconfirm ship dates

- ▶ Review invoicing and shipping information

- ▶ For major sub-vendors, obtain a copy of all (unpriced) purchase orders



D. Work Process Definitions

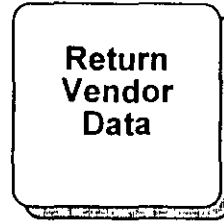
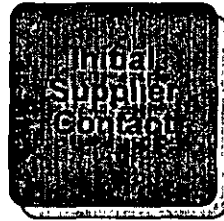

- Vendor Data Requirements - One of the most difficult processes to organize and maintain. Documents are expedited by Procurement Expeditors and / or Technical Document Control (TDC).

- ✓ Pre-Award (Buyer)

- ▶ Spend time identifying and agreeing on what data is required and how the Supplier will submit.
- ▶ Amend the VDR (Vendor Data Requirements) sheet to reflect agreed submittal requirements.
- ▶ Negotiate progress payments based on drawing submittals.
- ▶ Think about how to handle final data.
- ▶ Request standard documents from the Supplier rather than special engineered drawings.
- ▶ Request certified drawings on standard equipment instead of review drawings.

- ✓ Post Award (Expediter)

- ▶ Contact Supplier and reconfirm vendor document requirements and schedule
- ▶ Advise the responsible buyer when there is conflicting status.
- ▶ Expedite and report status until documents arrive.
- ▶ Due to many partial issues of documentation, a project must agree that milestone actual dates are satisfied when the following question is answered with a "yes":

Does the information received allow engineering to further its design?

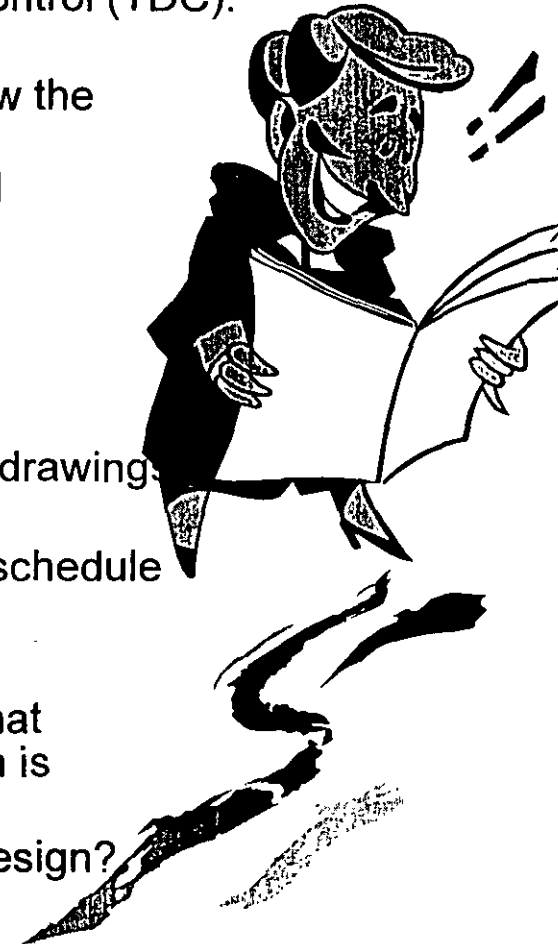

D. Work Process Definitions

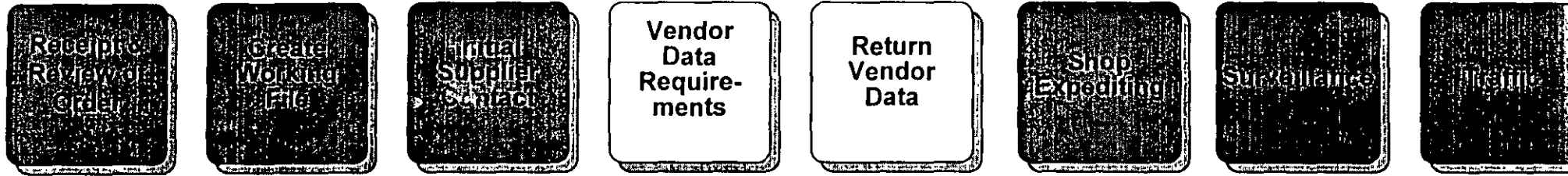

● Vendor Data Requirements (CONTINUED)

- ✓ External Expediting
 - ▶ Obtain current status from suppliers.
 - ▶ Advise Suppliers of internal document review status.
- ✓ Internal Expediting
 - ▶ Verify receipt of documents in TDC (Technical Document Control).
 - ▶ Monitor squad check review.
 - ▶ Confirm return issue of documents to supplier.
 - ▶ Document review status codes:
 - A Proceed
 - B Proceed as Noted - incorporate comments on certified drawings
 - C Do Not Proceed - resubmit for review
 - D Information Only - acknowledge receipt



D. Work Process Definitions

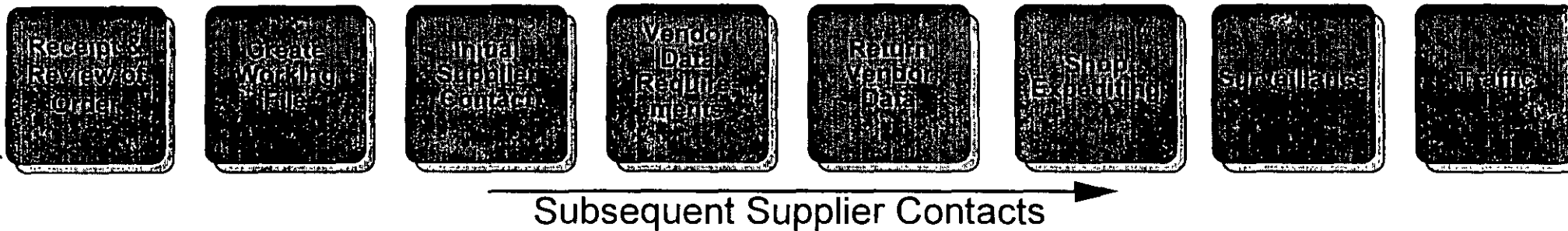

● Subsequent Supplier Contacts

- ✓ Maintenance calls with Suppliers to obtain current status in all areas of the schedule:
 - ▶ Drawings
 - ▶ Material purchase
 - ▶ Fabrication
- ✓ Fabrication Process
 - ▶ Learn each step of the fabrication process.
 - ▶ Record status as steps are completed.
 - ▶ Review the relationship between duration of fabrication steps and overall schedule.
 - ▶ Recognize plant shutdowns and confirm that these were accounted for up front.
 - ▶ Ask about potential bottle necks.
 - ▶ Determine the Supplier's critical milestone dates. (i.e. Drawings need to be returned by a certain date in order to meet the fabrication window. In the event of a change, does the change impact normal fabrication?)

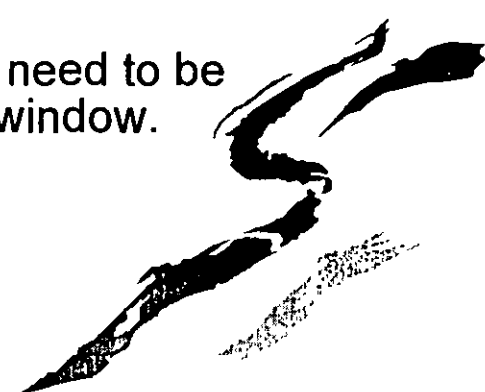

D. Work Process Definitions

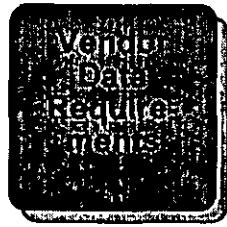
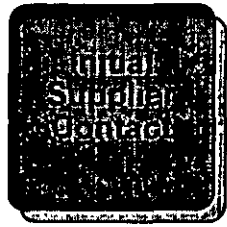

Shop Expediting

- ✓ Physical visits to the Supplier's shop to identify problems maintaining schedule.
- ✓ Physical visit to the Supplier's shop to assist in accelerating schedule
 - ▶ Local surveillance service
 - ▶ Project personnel (i.e. PPM, Project Engineer, Project Manager, Client)
- Surveillance (refer to module 9)
 - ✓ Level of criticality determined during surveillance planning
 - ▶ Surveillance Coordinator receives a copy of the Purchase Order and generates the assignment sheet.
 - ▶ Communicates status to Expediter via report and / or phone call.
- Traffic Coordination (refer to module 10)
 - ✓ Two weeks notification prior to shipment.
 - ✓ Weights and dimensions required



E. Expediting Execution

Expediting Approaches to Schedule Impacts:

- Schedule Delay - fabrication and / or shipping current promise dates exceed original promise schedule.
 - ✓ Cause for delay
 - ✓ Seller corrective action
 - ✓ Fluor Daniel assistance with sub-suppliers
 - ✓ Alternate sources of material supply
 - ✓ Extra shifts and overtime
 - ✓ Shop priority for Fluor Daniel work
- Accelerate Schedule - due to project change, may need one order or an entire area of orders earlier
 - ✓ Shop sequence
 - ✓ Extra shifts and overtime
 - ✓ Premium / Penalty
 - ✓ Fluor Daniel assistance with sub-suppliers
- Changes in Scope - design changes can happen at any time
 - ✓ Percentage complete
 - ✓ Cost and schedule impact
- Supplier and Sub-supplier non performance - punch list items after inspection ignored
 - ✓ Fluor Daniel to fix in the field and backcharge the Supplier
 - ✓ Supplier to fix in the field
 - ✓ Return equipment to the Supplier for correction
- Strikes and company closures - be creative
- Shutdowns
 - ✓ Project - planned time frame for construction to do tie-ins to existing lines
 - ✓ Supplier - planned vacation period usually summer and Christmas holidays

Note: European companies often close for an entire month



D. Module Review Exercise

As mentioned in previous modules, 10 Chilled Water Pumps have been purchased (P101 through P110).

Use the following criteria to discuss resolutions:

- P105 through P108 will be manufactured and shipped from Sweden.
- The original order showed all pumps shipping on the same date.
- Vendor data was submitted at the same time but P101 through P104 had an engineering hold due to a change in motor size during the review cycle and was returned one month later than the balance.
- Required at site dates remain the same per Construction.

Questions:

1. Because P105 through P108 are shipping from Sweden, they will not have the same ETA dates as the other pumps. In order to meet the RAS dates, what action can be taken?
2. How can RAS dates be met for P101 through P104 which were released one month later than the other pumps?
3. What is required administratively as a result of #2 above.



D. Module Review Exercise

Answers

1. This should have been addressed during the Purchase Order award stage. However...
 - A. By expediting closely with the Supplier, earlier ship dates may be achievable.
 - B. Coordinate efforts with surveillance and traffic to reduce potential delays.
 - C. Air freight entire pump or just the pump base to support construction activities.
2. Meeting RAS Dates
 - A. While the pumps were on hold, it should have been communicated to the Supplier the reason for the hold and determine the degree of risk to only fab release the pumps.
 - B. Confirm with the Supplier that the shop window is still achievable and if any fabrication time can be reduced by using additional shifts.
 - C. Ship the pump base only or the pumps without motors and assemble in the field.
 - D. Identify a better traffic route than LTL (less than truck load).
 - E. Fluor Daniel can assist the Supplier in expediting sub-suppliers or locating alternate sources of material.
3. A change order should be generated.

Main Point: executing the order gets more detailed than placing the order and reporting status becomes extremely important!





P101 MODULE NINE

Surveillance / Inspection



MODULE 9

Surveillance / Inspection

Purpose: To provide a general understanding of basic Surveillance and Inspection practices with an emphasis on:

- A. Surveillance / Inspection
- B. Levels of Surveillance
- C. Network
- D. Execution
- E. Module Review Exercise



A. Surveillance vs Inspection

Surveillance: The monitoring of the supplier quality and inspection program.

Inspection: The physical inspection of material / equipment conformity to quality standards.

Reasons for performing surveillance or inspection:

- Put the responsibility of the performance totally on the supplier
- Improve supplier quality performance
- Improve supplier relations
- Reduce inspection efforts and related costs

These services should begin during the front end planning phase and development of the project equipment list.

The project team which includes engineering, procurement, construction and the client decide which packages will require surveillance or inspection.

The procurement practices identifies language required for the different criticality ratings which need to be in the Sample P.O. and P.O. clauses.

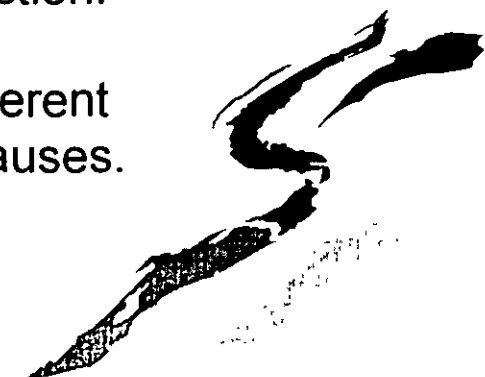

B. Levels of Surveillance

Criticality Rating			
Equipment Characteristics			
Design Process Complexity (1-4)			
Design Maturity (1-4)			
Manufacturing Complexity (1-4)			
Service Characteristics			
Operating (1-4)			
Personnel Safety (1-4)			
Financial Consequences (1-4)			
1	2	3	4
6-10	11-15	16-20	21-24

Supplier Experience Rating	
1	➡ No Experience
2	➡ Minimal Experience
3	➡ Previous Experience
4	➡ Extensive Experience

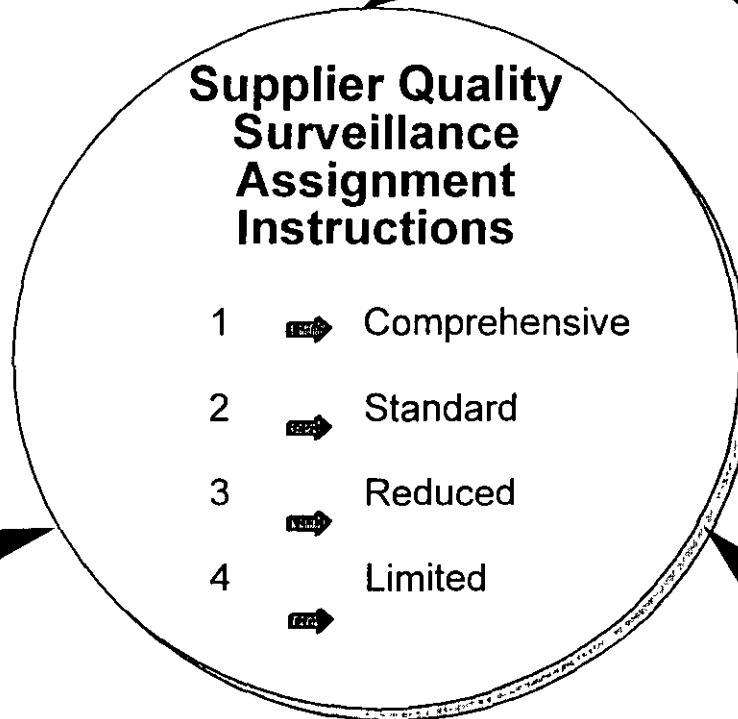

Supplier Quality Rating			
Purchase Order evaluations entered into Global Supplier Manager provide an excellent means for evaluating previous supplier performance.			
These ratings are based on a 100 point scale.			
1	2	3	4
< 60%	60-89%	90-99%	100%

The level of surveillance required for a given commodity is determined by averaging the results of the (3) rating processes described on this page.



C. Network

Each project is assigned a Project Surveillance Coordinator (PSC) who supports efforts during the planning and execution phases.

The PSC works with the PPM to develop a Project Surveillance Plan. The following elements make up this plan:

- Assignment Instructions
- Alignment Meetings
- Supplier Quality Surveillance System (SQSS)
 - Nonconformance Tracking
- Supplier Quality Reporting System (SQRS)
 - Surveillance Reports
 - Nonconformance Reports
 - Release Reports
- Measurement of Supplier Performance
- Assignment Close-out
- Supplier Surveys
- Supplier Quality Program Evaluation (SQPE)

Assignments are made and coordinated with the local, state or country inspector (see attached map). For countries where there is no Fluor Daniel representative, the PSC will contact the responsible FD office (based on geographical location) for obtaining a qualified local inspection service.



C. Network - International Resources

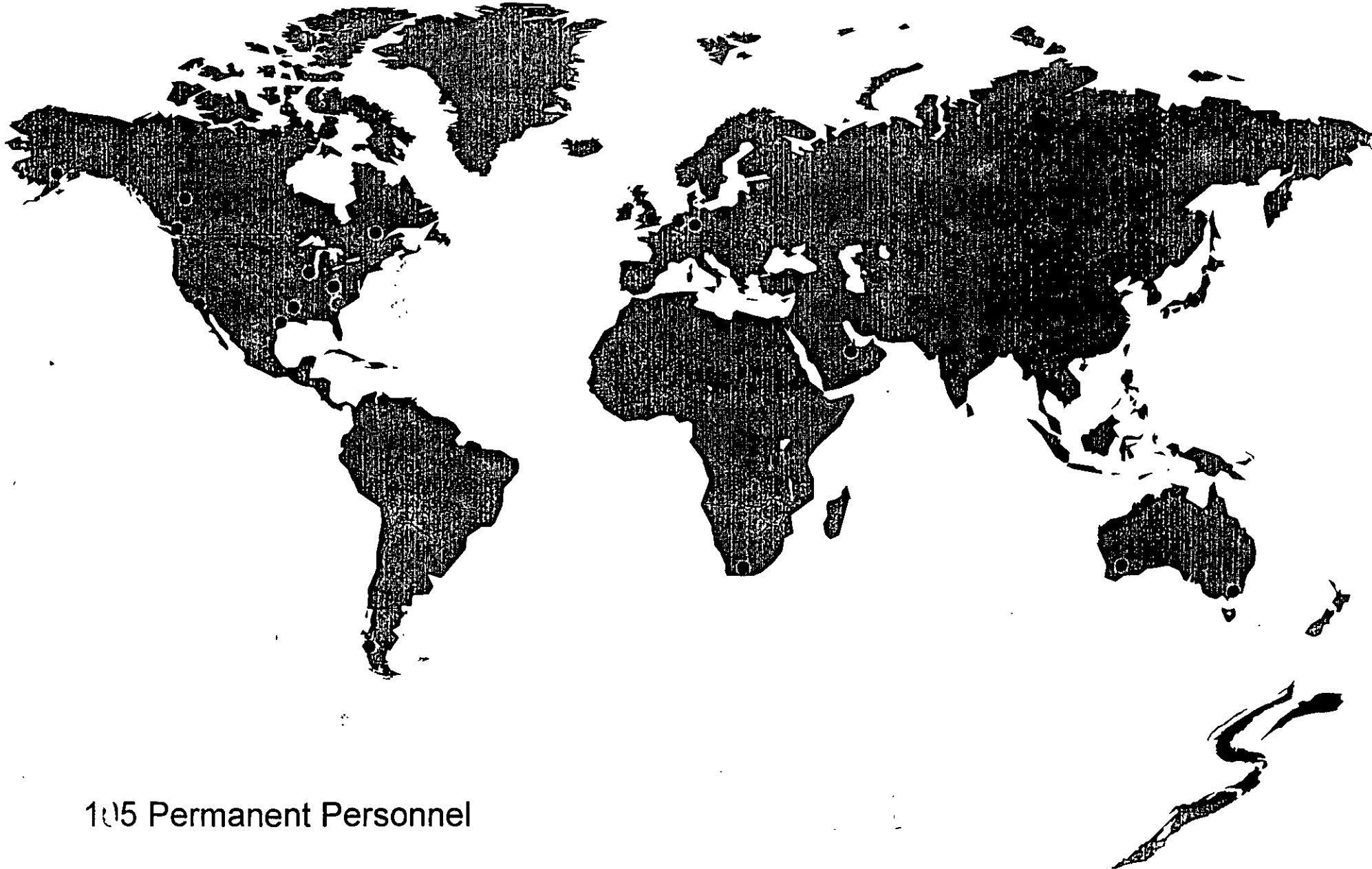

D. Execution

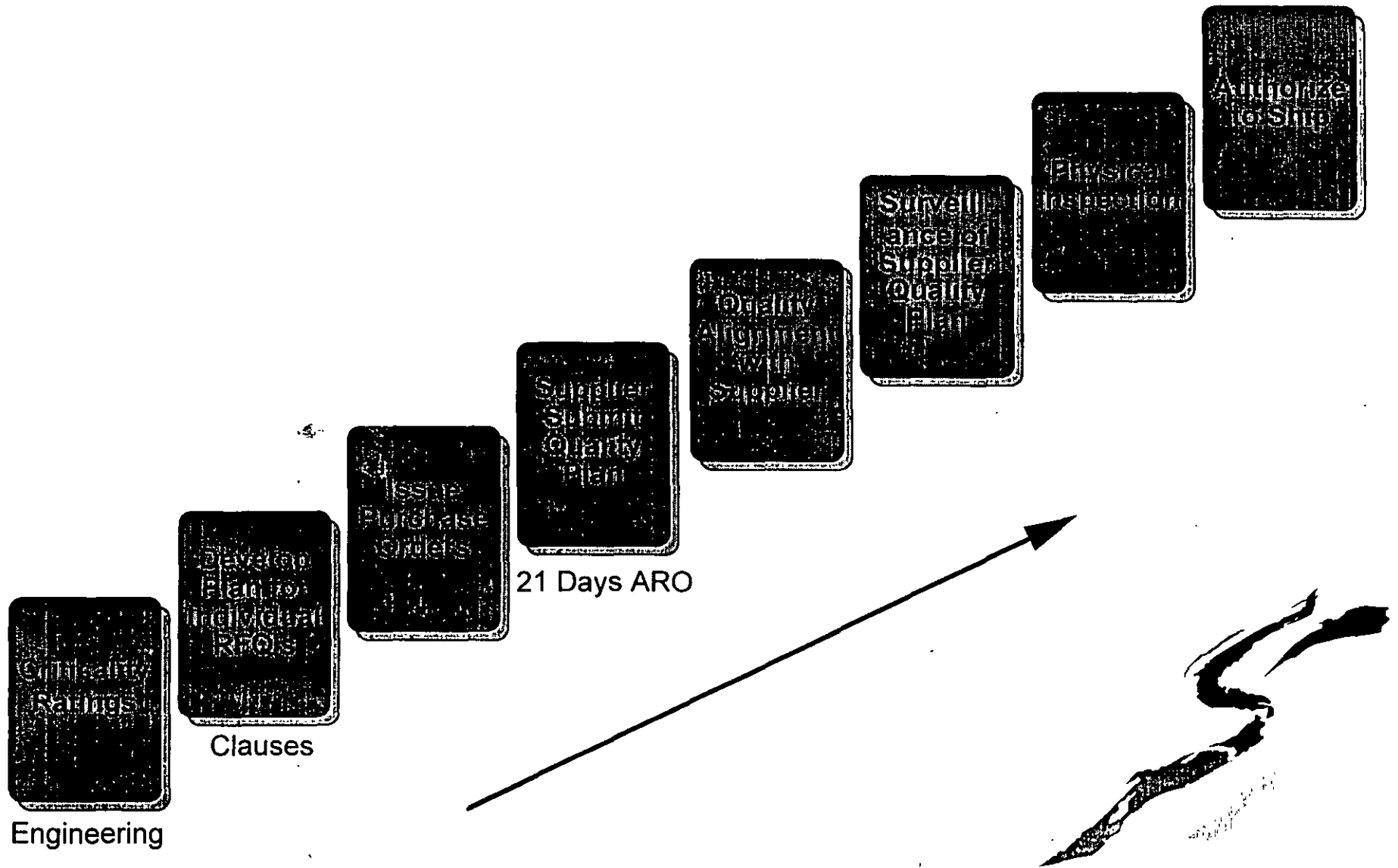

E. Module Review Exercise

As mentioned in previous modules, 10 chilled water pumps have been purchased (P101 through P110).

Use the following criteria to discuss resolutions:

- ▶ P105 through P108 are being manufactured and shipped from Sweden.
- ▶ Assertive expediting has maintained schedule for all pumps.
- ▶ The criticality ratings are :

P101 to P104 and P109 to P110	Level 3
P105 to P108	Level 2
- ▶ Surveillance is complete and all pumps are ready for final inspection.
- ▶ All pumps pass final inspection except P109 and P110 (pump base problem).

Questions:

1. How many assignment sheets will need to be prepared by the PSC?
2. What is the course of events for P109 and P110? (inspector / project)



E. Module Review Exercise

Answers

1. Two assignment sheets - (two manufacturing locations) requires one for each inspector.
2. Course of Events
 - Inspector issues supplier a non-conformance report (NCR).
 - Inspector notifies the PSC before leaving the shop and informs him / her of the pumps' status.
 - PSC arranges a conference call with the project and determines severity of the situation.
 - A decision needs to be made by the project whether to:
 - Ship to meet schedule and supplier fix in the field
 - Ship to meet schedule and field fix with backcharge
 - Do not ship and supplier fix in shop with re-inspection
 - Acknowledge NCR and accept "as is"
 - Inspector closes out NCR which documents resolution.

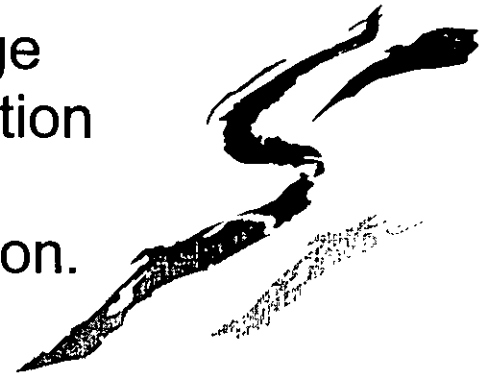

P101

MODULE TEN

Traffic & Logistics

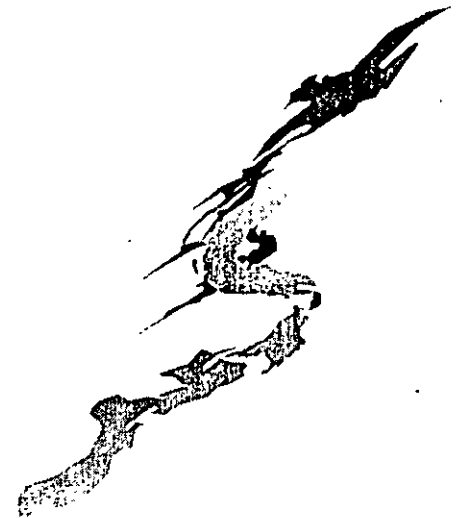
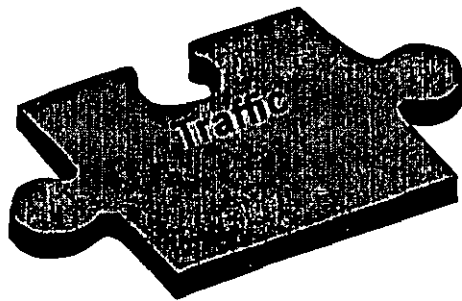
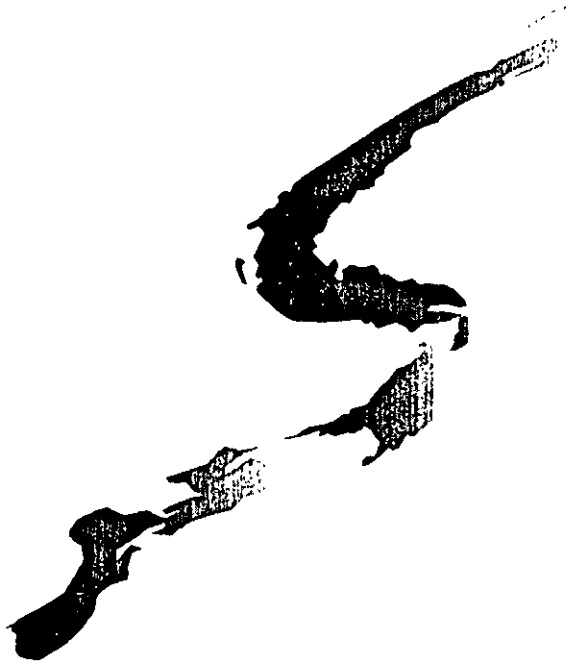

MODULE 10

Traffic

Purpose: To provide a general introduction to traffic with an emphasis on:

- A. Traffic & Logistics
- B. Shipping Terms
- C. Execution
- D. Module Review Exercise



A. Traffic and Logistics

What is traffic and Logistics?

It is a way to route articles from shipping point to final destination.

What is a logistics plan?

A strategy and procedure for routing all types of shipments on a project. It identifies shipments for priority and special handling.

Do all projects need a logistics plan?

Yes. The degree of detail and complexity depends on the project (i.e. domestic vs abroad)

Why do we offer a traffic service?

To add value to the project, reduce cost of freight, increase accountability and maintain high quality.

Does each project require a traffic specialist?

No. The traffic and logistics specialist is available to support during logistics planning and answer all questions related to special situations.

Who does the routing of shipments?

The responsible buyer / expeditor on routine loads. The traffic specialist when requested.



B. Shipping Terms and Terminology

Standard Freight Terms on a Purchase Order:

<u>Term</u>	<u>Description</u>	<u>Freight Respon.</u>	<u>Title Transfer</u>
FOB Jobsite	Free Onboard to Jobsite	Seller	Final Destination
Shipping Pt	Shipping Point	Buyer	Shipping Pt
Shipping Pt/PPA	Shipping Point / Prepay & Add to Invoice	Buyer	Shipping Pt
Shipping PT/FFA	Shipping Point / Full Freight Allowed	Seller	Shipping Pt

Which freight terms are most desired:

Clients request FOB Jobsite because it puts sole responsibility of shipment on the Seller including damage claims. What they don't realize, is how much markup the seller puts on freight in the purchase order.

Fluor Daniel prefers Shipping Point with Third Party Billing. This way we can route the shipment the best, fastest and cheapest way as well as manage the payments of freight invoices. A lot of money can be saved on the project by reducing freight costs as well as minimizing any damage claims.

What are Incoterms?

Global shipping terms understood by all countries for shipments abroad. These terms address all aspects of foreign cargo, responsibility of the steps necessary to move the cargo as well as cost (refer to chart).



B. Shipping Terms and Terminology

Breakdown Dividing Responsibility and Charges Between Buyer (Importer) and Seller (Exporter)

Responsibility & Charges Service	EXW Ex Works	FCA Free Carrier	FAS Free Alongside Ship	FOB US Port Free Onboard Vessel	CFR Cost & Freight	CIF Cost Insurance Freight	CPT Carriage Paid To	CIP Carriage Insurance Paid To	DAF Delivery at Frontier	DES Delivered Ex Ship	DEQ Delivered Ex Quay Duty Paid	DDU Delivered Duty Unpaid	DDP Delivered Duty Paid
Warehouse Storage at Point of Origin	SELLER	SELLER	SELLER	SELLER	SELLER	SELLER	SELLER	SELLER	SELLER	SELLER	SELLER	SELLER	SELLER
Warehouse Labor Charge at Point of Origin	SELLER	SELLER	SELLER	SELLER	SELLER	SELLER	SELLER	SELLER	SELLER	SELLER	SELLER	SELLER	SELLER
Export Packing	SELLER	SELLER	SELLER	SELLER	SELLER	SELLER	SELLER	SELLER	SELLER	SELLER	SELLER	SELLER	SELLER
Loading at Point of Origin	BUYER	SELLER	SELLER	SELLER	SELLER	SELLER	SELLER	SELLER	SELLER	SELLER	SELLER	SELLER	SELLER
Inland Freight	BUYER	BUYER	SELLER	SELLER	SELLER	SELLER	SELLER	SELLER	SELLER	SELLER	SELLER	SELLER	SELLER
Port Receiving Charges	BUYER	BUYER	SELLER	SELLER	SELLER	SELLER	SELLER	SELLER	SELLER	SELLER	SELLER	SELLER	SELLER
Forwarders Fee	BUYER	BUYER	SELLER	SELLER	SELLER	SELLER	SELLER	SELLER	SELLER	SELLER	SELLER	SELLER	SELLER
Loading on Ocean Carrier	BUYER	BUYER	BUYER	SELLER	SELLER	SELLER	SELLER	SELLER	SELLER	SELLER	SELLER	SELLER	SELLER
Ocean / Air Freight	BUYER	BUYER	BUYER	BUYER	SELLER	SELLER	SELLER	SELLER	SELLER	SELLER	SELLER	SELLER	SELLER
Charges in Foreign Port / Airport	BUYER	BUYER	BUYER	BUYER	BUYER	BUYER	SELLER	SELLER	SELLER	BUYER	SELLER	SELLER	SELLER
Customs Duties and Taxes Abroad	BUYER	BUYER	BUYER	BUYER	BUYER	BUYER	BUYER	BUYER	BUYER	BUYER	SELLER	BUYER	SELLER
Delivery Charges to Final Destination	BUYER	BUYER	BUYER	BUYER	BUYER	BUYER	BUYER	BUYER	BUYER	BUYER	BUYER	SELLER	SELLER



C. Execution

What must a person be familiar with to route cargo?

- The purchase order and supplier
- The schedule and fabrication location / process
- The local carriers
- The shipping terms and terminology
- The use of Service Guides
- The identification and handling of hazardous materials
- The import / export (customs & tariffs) process
- The processing of oversized loads & special insurance

What are the different types of transportation services?

<u>Carrier</u>	<u>Description</u>	<u>Method</u>
UPS	United Parcel Service	Truck or
A / F	Air Freight	Plane
LTL	Less Than Truck Load	Plane
Exclusive	Dedicated Truck	Truck
R / R	Rail Road	Truck
Ocean	Ocean	Train
		Ship



D. Module Review Exercise

The 10 chilled water pumps (P101 through P110) are ready to ship.

Use the following criteria to answer the questions below

- P101 through P104 & P109 to P110 are shipping from Michigan to the jobsite in Salt Lake City, Utah with P.O. freight terms Shipping Point.
- P105 through P108 are shipping from Sweden to Salt Lake City, Utah with P.O. freight terms FOB U.S. Port
- At delivery, the carrier door was opened and P101 was found damaged.

Questions:

1. What are the traffic steps to move pumps P101 - P104, P109, P110 to jobsite?
2. For pumps shipping from Sweden, what does FOB U.S. Port mean?
3. What incoterm best describes total responsibility of the seller from Sweden to Utah?
4. What steps need to be taken for the damaged P101 pump?

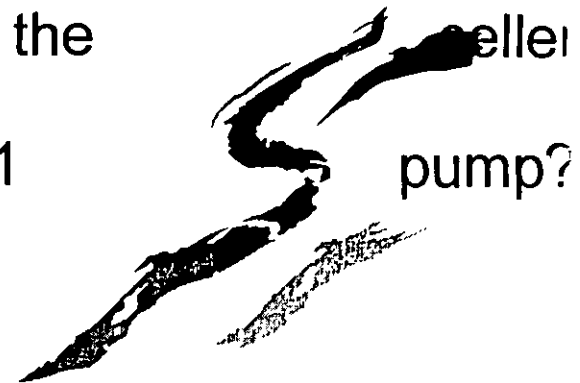

D. Module Review Exercise

Answers

1. The traffic steps required to move pumps from Michigan to Utah are:

- Ship:

- ✓ Review schedule to determine if LTL or exclusive truck is required.

- ✓ Obtain weights and dimensions

- ✓ Use service guide to identify carrier of choice (FD has contractual agreements with some carriers; consult traffic coordinator)

- Confirm number of distribution points and if cargo is transported to different trucks

- Confirm if single carrier shipment or transfer between carriers

- ✓ Issue "shipping notice to proceed papers" to carrier

- ✓ Confirm freight billing information is correct

- ✓ Coordinate carrier pick-up of cargo

- Track:

- ✓ Confirm cargo pick-up

- ✓ Obtain pro number, trailer number and ETA of shipment

- ✓ Check with dispatch regularly to determine progression of shipment

- ✓ Confirm receipt and shipment condition with site receiving



D. Module Review Exercise

Answers

2. FOB U.S. Port means that seller is responsible for all activities to get the cargo loaded onto the ship. As soon as the shipment is loaded, the buyer takes responsibility of the freight, foreign port charges, customs / duties / taxes and delivery charges to final destination.
3. The incoterm that best describes total seller responsibility is DDP. Delivered Duty Paid.
4. P101 Damaged pump steps:
 - ✓ Take a picture of the pump while in the truck
 - ✓ Determine whether to unload
 - ✓ Mark "Damaged" on the bill of lading as well as the packing list
 - ✓ Initiate and finalize damage claim with carrier



P101 MODULE ELEVEN

Warehousing

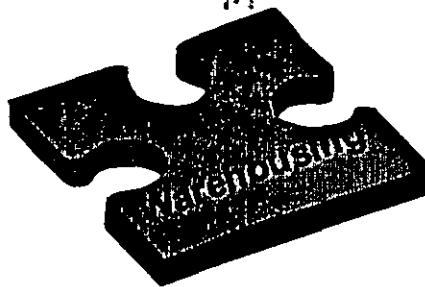

MODULE 11

Warehousing

Purpose: To outline the responsibilities of warehousing.

- A. Receiving
- B. Checking
- C. Storing
- D. Protecting
- E. Issuing
- F. Reporting
- G. Maintaining Records
- H. Module Review Exercise



A. Receiving

That function of a warehouse organization that initially receives all materials, equipment, tools, and supplies onto a project. Receiving then directs these items to the location where they will be checked, stored and/or used. This ensures that they are properly unloaded and in the quantity and condition described on the delivery documents.

The warehouse should be the first stop for everything coming onto the project. All equipment, materials, tools, and supplies should be routed through the warehouse receiving section so that each shipment can be duly recorded and directed to where it should go. This not only includes materials and equipment that will be off loaded at the warehouse but also supplies for the office, rental equipment, tools, shipments for contractors, etc.

What are the benefits of the Receiving function?

- CONTROL
- QUANTITY / QUALITY CHECK
- RECORD
- FIRST STOP FOR EVERYTHING
- SHORTAGE, DAMAGE
- STORAGE LOCATION



B. Checking

The act of counting and inspecting the materials, equipment, tools and supplies received on a project. Checking ensures that all items are as ordered per the purchase order, and are in the condition and quantity described in the shippers documents.

Always verify the following:

- ✓ Discrepancies
- ✓ Documents
- ✓ Holding Area
- ✓ Double Check
- ✓ Assistance
- ✓ O S & D Report



C. Storing

The placing of materials not yet required by the project in a designated storage location where they can be easily located and identified at a later date.

The following are key factors when storing

- ✓ Security
- ✓ Space Restrictions - limited laydown
- ✓ Maintenance - rotating equipment
- ✓ Climate Control
- ✓ Accessibility

STORAGE LEVELS

- Level A: Dust free and humidity controlled environment
- Level B: Inside, temperature controlled storage
- Level C: Inside storage with protection from rain, snow etc. but does not require heat
- Level D: Outside storage, gravel covered with good drainage



D. Protecting

The safeguarding of stored materials, equipment, tools and supplies so as to protect them from damage, theft and misuse until they are required by construction personnel.

The following items should be considered in regards to protection:

- ✓ Creativity
- ✓ Protect Openings
- ✓ Common Sense
- ✓ Maintenance



E. Issuing

The act of transferring materials, equipment, tools and supplies from the warehouse to construction contractors or Client designated personnel.

The following are key factors related to issuing:

- Work Packages/Work Breakdown Structures

- Contract Obligations

- Bill of Materials by Subcontractor or Work Package

- Scheduling of Issue Dates Based Upon Mobilization Dates

- Warehouse Manpower and Equipment Availability



F. Reporting

providing information in hard copy and / or via computer concerning the receipt, issue, condition, status, and other activities of the materials, equipment, tools and supplies handled by the warehouse.

Reports are issued to:

- Project Management
- Cost and Scheduling
- Superintendents
- Accounting
- Subcontractors
- Procurement



G. Maintaining Records

The recording of detailed information concerning the activities of the materials, equipment, tools, and supplies handled by the warehouse.

Including but not limited to:

- A complete history of material requirements
- Average purchase costs for all items
- Complete supplier listing



H. Module Review Exercise

The 10 chilled water pumps (P101 through P110) are at the warehouse and ready for receipt.

Use the following criteria and discuss:

- Disposition of damaged pump P101 identified in the previous Traffic Module
- All other pumps seem to be okay

Questions:

1. What happens to pump P101 while the damage claim is proceeding?
2. What are the steps to receive all pumps?
3. How does receiving affect payment of the pumps?
4. How important is the warehouse to the material control efforts?



H. Module Review Exercise

Answers

1. Damaged pump P101 is set aside with a "Hold / Damage" tag on it until repair is resolved.
2. Steps to receiving pumps:
 - Pull purchase order and compare packing list for conformity
 - Prepare field receiving report "FRR" for all pumps and one overage, shortage, damage "OS&D" report for P101
 - Store pumps in designated location until ready for use (maintenance may be required on the pumps if storage is for a long period of time)
3. The "FRR" is Fluor Daniel's official document that supports payments. It documents that material has been received and describes its condition. Thus, one FRR is issued for all pumps and an OS&D noted on P101. Payment can proceed on all pumps but P101 which is pending OS&D resolution which states repair or replacement. If the OS&D is dispositioned, "carrier charge" then payment is made to the pump supplier.
4. The warehouse and its staff are the key focus for material control. They receive maintain and issue "all" material.





P101 MODULE TWELVE

Field Procurement

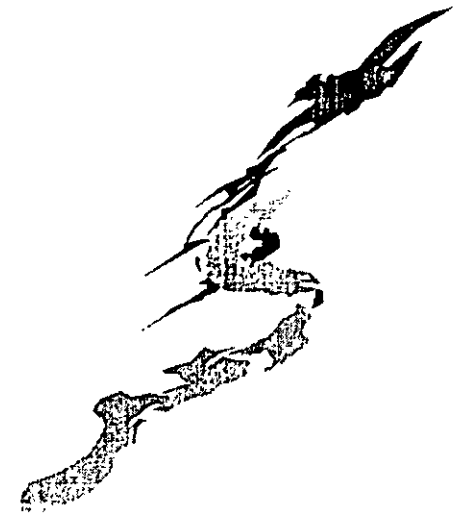
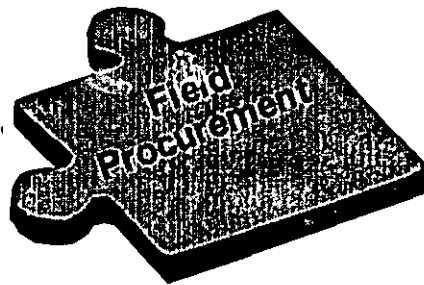

MODULE 12

Field Procurement

Purpose: To outline the responsibilities of field procurement with an emphasis on:

- A. Purchasing in the Field
- B. Planning for Field Procurement
- C. Challenges in the Field
- D. Module Review Exercise



MODULE 12

Field Procurement

Purpose: To outline the responsibilities of field procurement with an emphasis on:

- A. Purchasing in the Field
- B. Planning for Field Procurement
- C. Challenges in the Field
- D. Module Review Exercise



A. Purchasing in the Field

What is Field Procurement?

It is a way of procuring goods and services at the jobsite close to both construction needs and local suppliers.

When does Field Procurement start?

It depends on what type of project:

- EPC Procurement begins in the home office, transfers to the field and completes.
- EPCM Procurement begins in the home office, transfers to the field and completes.
- C
 1. Procurement begins in the home office of another design engineering firm, transfers to the field and completes.
 2. Procurement begins in the field at the time of construction.

What is the normal scope of field procurement?

Normally, scope includes bulks, wrap up of engineered equipment and instrumentation.

Is field purchasing always "emergency" buying?

No. "Emergency" buying costs money and the culture of "buying fast" should be "buying smart" which requires proper planning to reduce cost. If "buying smart" is implemented, then true emergencies (i.e. shut downs etc.) can be addressed at the time of occurrence.

Is everything purchased with a purchase order?

No. Petty cash is available for small purchases and same day pick up.
(refer to Procurement Practices)



A. Purchasing in the Field

What is Field Procurement?

It is a way of procuring goods and services at the jobsite close to both construction needs and local suppliers.

When does Field Procurement start?

It depends on what type of project:

- EPC Procurement begins in the home office, transfers to the field and completes.
- EPCM Procurement begins in the home office, transfers to the field and completes.
- C
 1. Procurement begins in the home office of another design engineering firm, transfers to the field and completes.
 2. Procurement begins in the field at the time of construction.

What is the normal scope of field procurement?

Normally, scope includes bulks, wrap up of engineered equipment and instrumentation.

Is field purchasing always "emergency" buying?

No. "Emergency" buying costs money and the culture of "buying fast" should be "buying smart" which requires proper planning to reduce cost. If "buying smart" is implemented, then true emergencies (i.e. shut downs etc.) can be addressed at the time of occurrence.

Is everything purchased with a purchase order?

No. Petty cash is available for small purchases and same day pick up.
(refer to Procurement Practices)



B. Planning for Field Procurement

In the taskforce / home office environment, planning for the purchase of construction materials should begin early. (refer to Module 1)

- **EPC**

- Determine strategy for what is to be purchased early
- Determine engineering support for material take offs
- Establish local blanket orders prior to relocating to the field
- Take advantage of the contractual Fluor Daniel key supplier agreements
- Prepare for receipt of material
- Implement "just in time" ordering and receiving

- **EPCM**

- Same steps as above except determine what will be purchased by Fluor Daniel and what will be purchased by contractors
- Complete a Material Responsibility Matrix for each contract package
- Determine if handling of material in the field will be by contractor or Fluor Daniel

- **Construction**

- Option 1 Same steps as EPC if able to participate in the "other than FD" engineering firm's early phases
 - Option 2 Begin with Module 1 and prepare for purchasing in the field
- Use Modules 2 - 12 as a guideline for all aspects of the construction phase
- Factors to consider:
- Less time to establish effective blanket orders
 - Shorter schedule to obtain materials
 - Material more costly due to short lead times (stocking fees)
 - Greater levels of surplus



B. Planning for Field Procurement

In the taskforce / home office environment, planning for the purchase of construction materials should begin early. (refer to Module 1)

- EPC

- Determine strategy for what is to be purchased early
- Determine engineering support for material take offs
- Establish local blanket orders prior to relocating to the field
- Take advantage of the contractual Fluor Daniel key supplier agreements
- Prepare for receipt of material
- Implement "just in time" ordering and receiving

- EPCM

- Same steps as above except determine what will be purchased by Fluor Daniel and what will be purchased by contractors
- Complete a Material Responsibility Matrix for each contract package
- Determine if handling of material in the field will be by contractor or Fluor Daniel

- Construction

- Option 1 Same steps as EPC if able to participate in the "other than FD" engineering firm's early phases
 - Option 2 Begin with Module 1 and prepare for purchasing in the field
- Use Modules 2 - 12 as a guideline for all aspects of the construction phase
 - Factors to consider: Less time to establish effective blanket orders
 - Shorter schedule to obtain materials
 - Material more costly due to short lead times (stocking fees)
 - Greater levels of surplus



B. Planning for Field Procurement

In the taskforce / home office environment, planning for the purchase of construction materials should begin early. (refer to Module 1)

- **EPC**

- Determine strategy for what is to be purchased early

- Determine engineering support for material take offs

- Establish local blanket orders prior to relocating to the field

- Take advantage of the contractual Fluor Daniel key supplier agreements

- Prepare for receipt of material

- Implement "just in time" ordering and receiving

- **EPCM**

- Same steps as above except determine what will be purchased by Fluor Daniel and what will be purchased by contractors

- Complete a Material Responsibility Matrix for each contract package

- Determine if handling of material in the field will be by contractor or Fluor Daniel

- **Construction**

- Option 1 Same steps as EPC if able to participate in the "other than FD" engineering firm's early phases

- Option 2 Begin with Module 1 and prepare for purchasing in the field

- Use Modules 2 - 12 as a guideline for all aspects of the construction phase

- Factors to consider: Less time to establish effective blanket orders

- Shorter schedule to obtain materials

- Material more costly due to short lead times (stocking fees)

- Greater levels of surplus

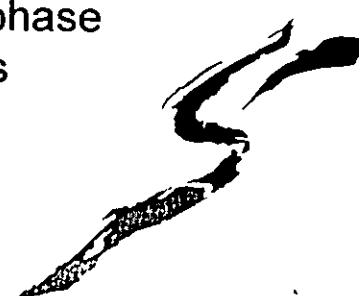

C. Challenges in the Field

Understand the construction schedule:

Always be aware of construction needs and strive to support them.

Build relationships with local suppliers:

The local suppliers are the only support during critical times.

Familiarize yourself with sources of supply that are readily available:

If local suppliers cannot provide, you must be prepared to locate material elsewhere.

Familiarize yourself with material types to obtain equals and partials:

Your level of material understanding needs to be high to support the use of substitutes.

Communicate with construction, suppliers and the client:

Communication skills are a must to keep all parties informed.

Material control:

Warehousing should alert material control when material levels are low and issue the material required per the bill of material.

Issue material to contractors in the order construction is sequenced:

Contractors are notorious for re-sequencing their work which exhausts materials on hand.

Teamwork:

Teamwork is essential by all parties and members of the field construction staff.



C. Challenges in the Field

Understand the construction schedule:

Always be aware of construction needs and strive to support them.

Build relationships with local suppliers:

The local suppliers are the only support during critical times.

Familiarize yourself with sources of supply that are readily available:

If local suppliers cannot provide, you must be prepared to locate material elsewhere.

Familiarize yourself with material types to obtain equals and partials:

Your level of material understanding needs to be high to support the use of substitutes.

Communicate with construction, suppliers and the client:

Communication skills are a must to keep all parties informed.

Material control:

Warehousing should alert material control when material levels are low and issue the material required per the bill of material.

Issue material to contractors in the order construction is sequenced:

Contractors are notorious for re-sequencing their work which exhausts materials on hand.

Teamwork:

Teamwork is essential by all parties and members of the field construction staff.



D. Module Review Exercise

Construction is ready to install the ten chilled water pumps P101 through P110.

Use the following criteria and discuss:

- The bill of material has been issued to the warehouse and they are pulling all material requested for installation.
- The warehouse identifies that some material is outstanding, thus a potential schedule delay could ensue.
- In addition to outstanding material, it has been identified that some material is short

Questions:

1. Who issues the bill of material (BOM) or field material request (FMR) form?
2. What are the steps required to satisfy outstanding or short materials?



D. Module Review Exercise

Construction is ready to install the ten chilled water pumps P101 through P110.

Use the following criteria and discuss:

- The bill of material has been issued to the warehouse and they are pulling all material requested for installation.
- The warehouse identifies that some material is outstanding, thus a potential schedule delay could ensue.
- In addition to outstanding material, it has been identified that some material is short

Questions:

1. Who issues the bill of material (BOM) or field material request (FMR) form?
2. What are the steps required to satisfy outstanding or short materials?



D. Module Review Exercise

Answers

1. The BOM or FMR is issued by the field engineer / area superintendent per drawing in construction installation sequence. This person authorizes these forms if material is requested by a contractor. The warehouse pulls the material and prepares it for pick up or delivery to the work site. It is the superintendent's responsibility in the case of a contractor requesting material that supports the construction sequence.
2. Steps required to satisfy outstanding or short material:
Construction notifies the field engineer
Short:
 - Field engineer issues requisition for short material
 - Purchasing buys the material
 - Material is delivered
 - Warehouse informs construction of material availability and issuesOutstanding:
 - Field engineer notifies expediter
 - Expediter contacts supplier and establishes delivery intentions or work around plan

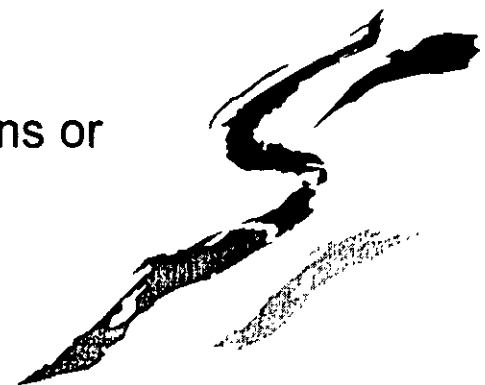



MATERIAL REQUIREMENTS PLANNING

MATERIAL REQUIREMENTS PLANNING

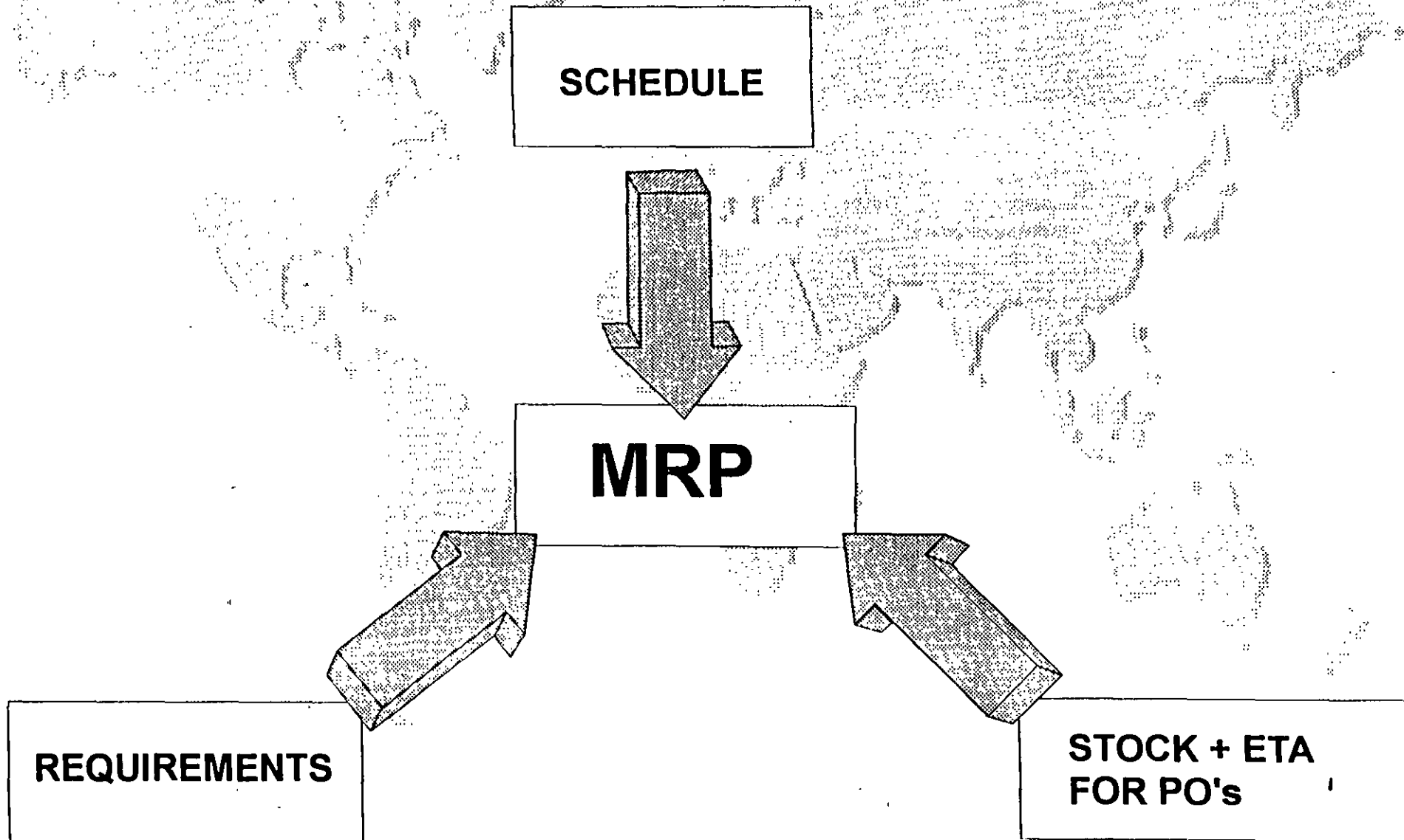

DESTINATIONS

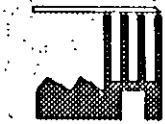

SHOP B



SHOP C

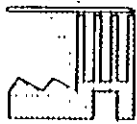

SHOP A

FIELD



DESTINATIONS ARE USED TO INDICATE WHERE OUTSTANDING PO ITEMS ARE BEING SHIPPED TO. MRP USES THIS (AS WELL AS THE STOCK LEVELS) TO DETERMINE MATERIAL AVAILABILITY AT EACH SHOP OR FIELD/SITE.

SCHEDULE



FIELD

TERMINATIONS	
CLEAR	_____
GRADE	_____
LAY	_____
PREP	_____
SET	_____

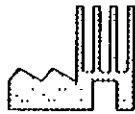

SHOP A

TERMINATIONS	
DESIGN	_____
APPROVE	_____
LAYOUT	_____
WELD	_____
FINISH	_____
PREP	_____



SHOP B

TERMINATIONS	
DESIGN	_____
APPROVE	_____
LAYOUT	_____
WELD	_____
FINISH	_____
PREP	_____



SHOP C

TERMINATIONS	
DESIGN	_____
APPROVE	_____
LAYOUT	_____
WELD	_____
FINISH	_____
PREP	_____

REQUIREMENTS

DRAWINGS

PLANS

LAYOUTS

DIAGRAMS

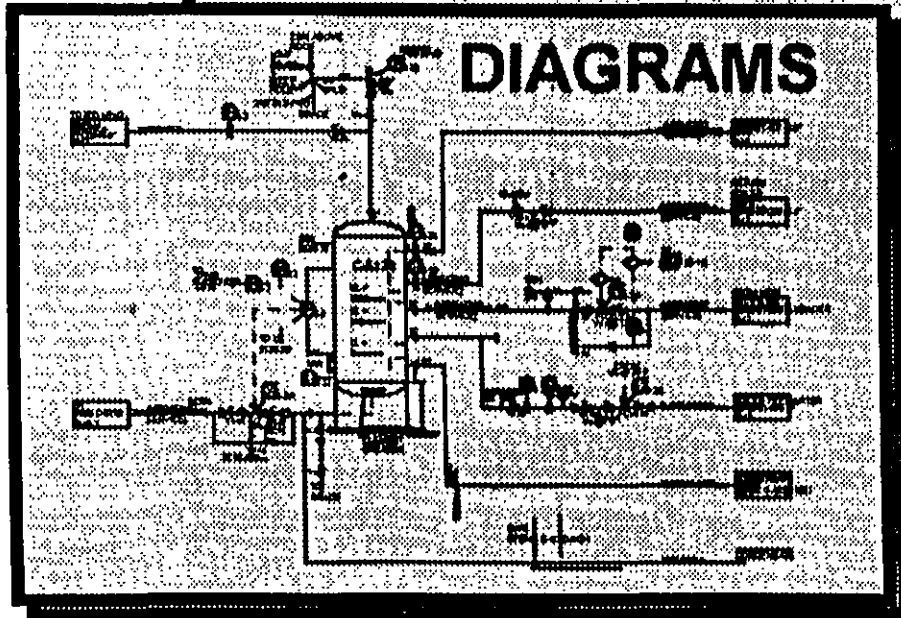

AVAILABILITY

STOCK

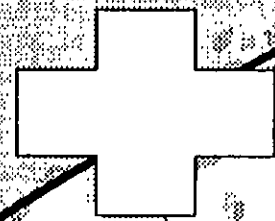

ETA

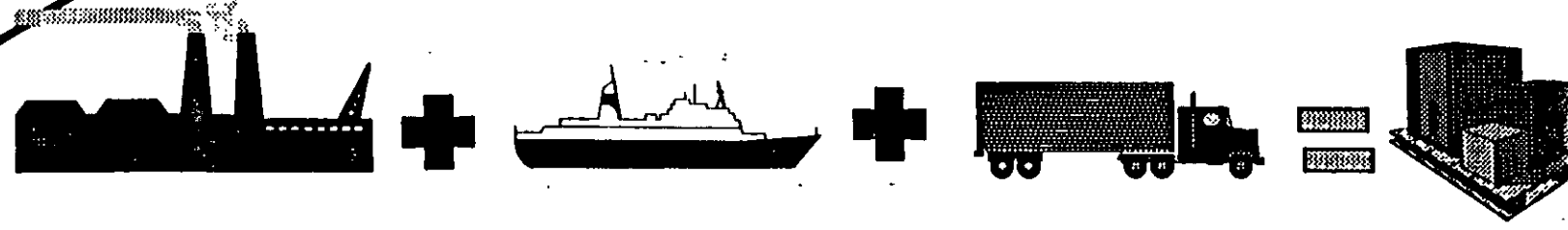
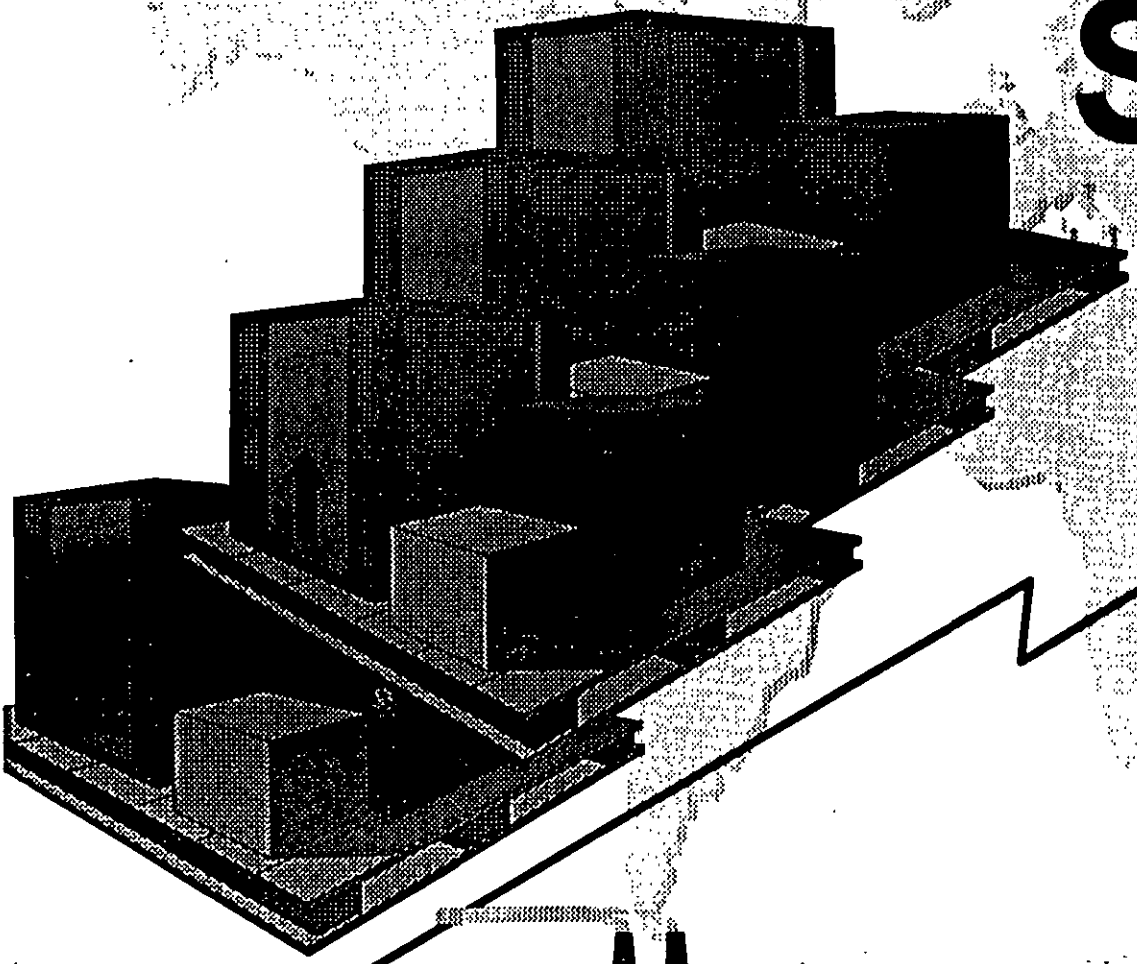

How Do We Get New Work?

Advertising
Joint Ventures

Client Referrals
Executive
Contracts

Existing Projects, Change Orders,
Scope Expansion

Proposals and Presentations



MATERIAL REQUIREMENTS PLANNING

MATERIAL REQUIREMENTS PLANNING

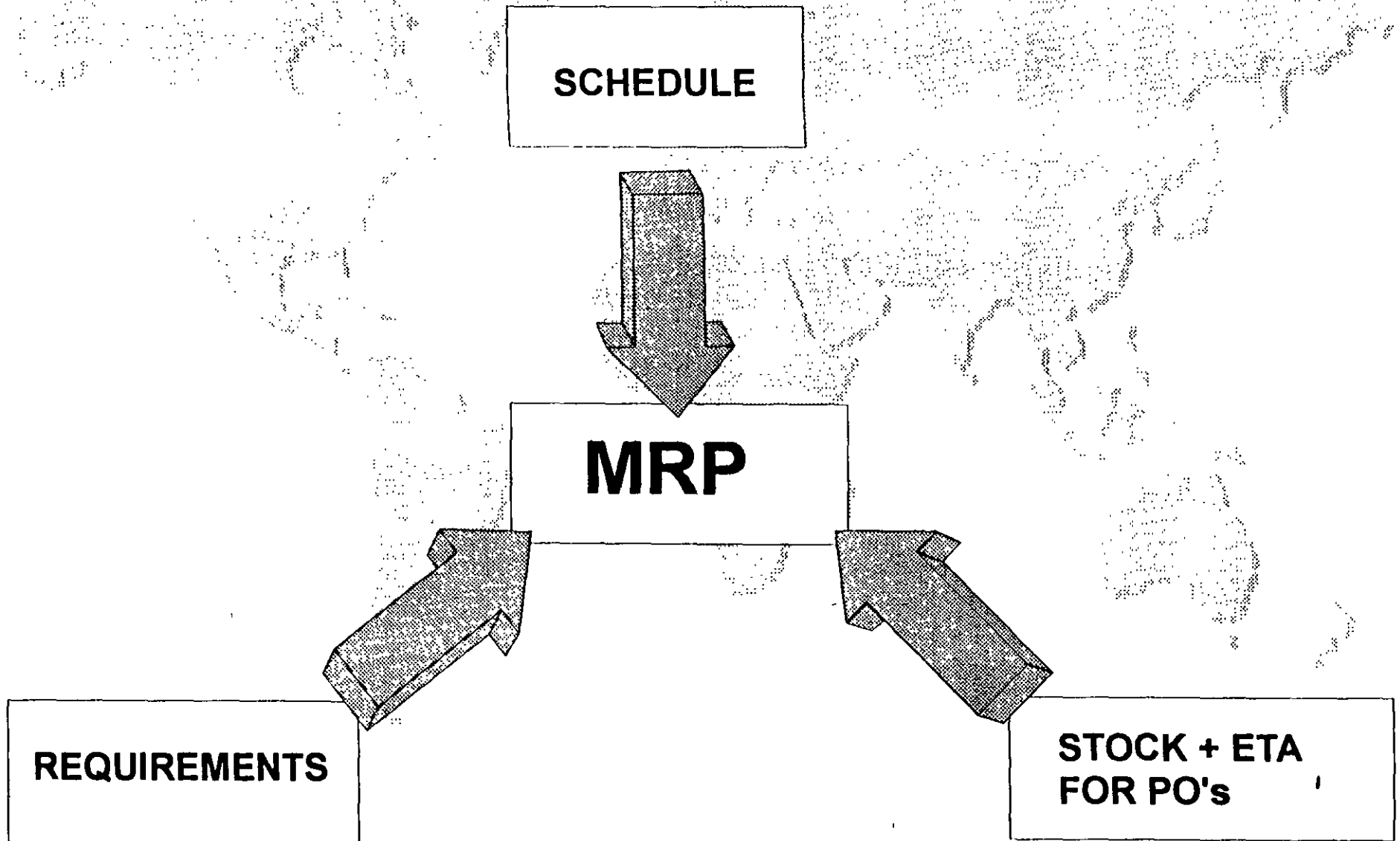

DESTINATIONS



SHOP B



SHOP C



SHOP A



FIELD

DESTINATIONS ARE USED TO INDICATE WHERE OUTSTANDING PO ITEMS ARE BEING SHIPPED TO. MRP USES THIS (AS WELL AS THE STOCK LEVELS) TO DETERMINE MATERIAL AVAILABILITY AT EACH SHOP OR FIELD/SITE.

SCHEDULE



FIELD

JENNIFERSON	
CLEAR	_____
GRADE	_____
LAY	_____
PREP	_____
SET	_____



SHOP A

JENNIFERSON	
DESIGN	_____
APPROVE	_____
LAYOUT	_____
WELD	_____
FINISH	_____
PREP	_____



SHOP B

JENNIFERSON	
DESIGN	_____
APPROVE	_____
LAYOUT	_____
WELD	_____
FINISH	_____
PREP	_____



SHOP C

JENNIFERSON	
DESIGN	_____
APPROVE	_____
LAYOUT	_____
WELD	_____
FINISH	_____
PREP	_____

REQUIREMENTS

DRAWINGS

PLANS

LAYOUTS

DIAGRAMS

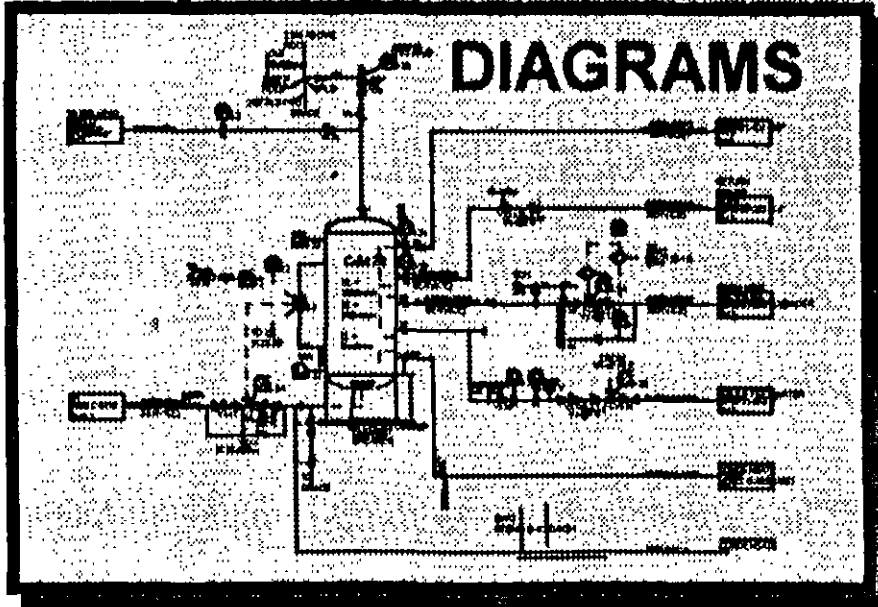

AVAILABILITY

STOCK

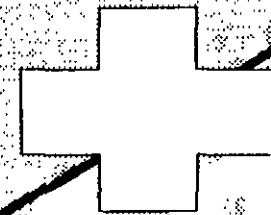

ETA

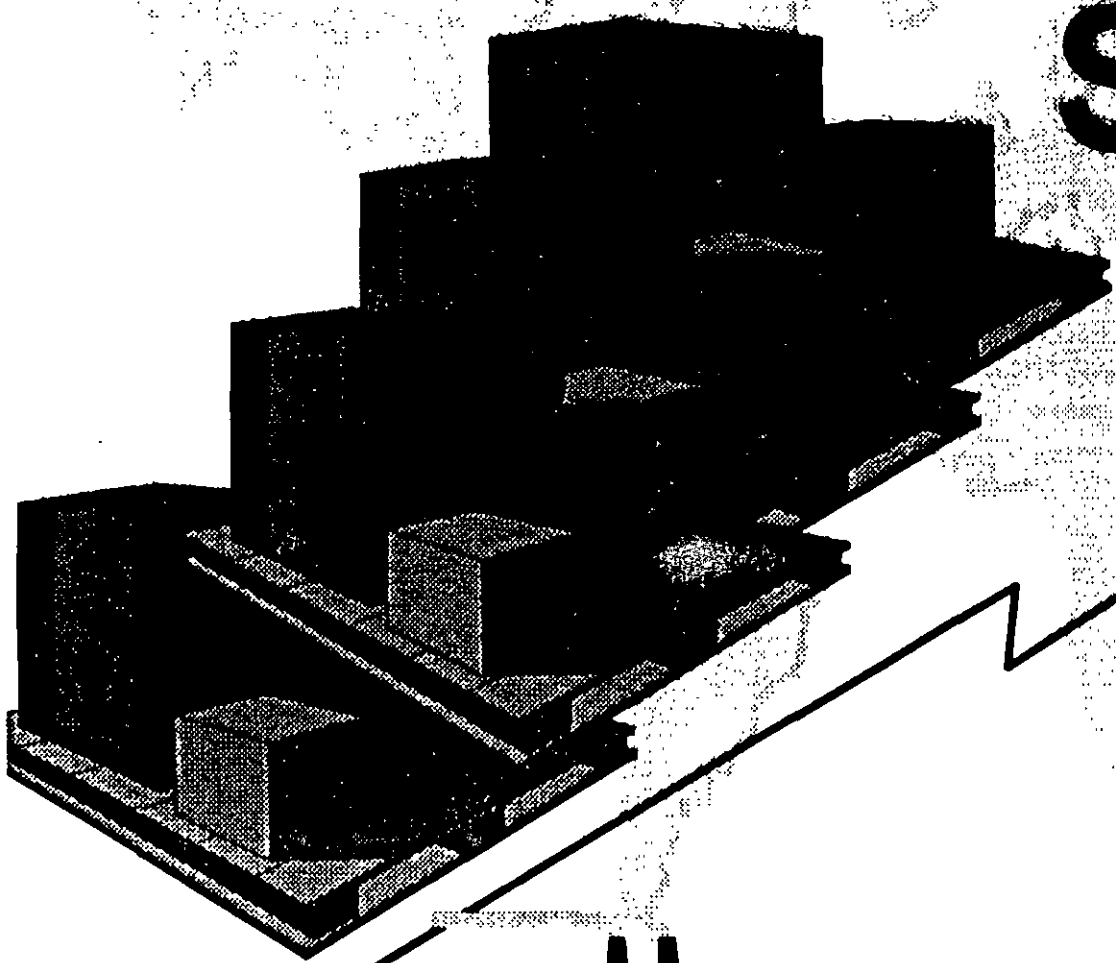

CONTRACTS

John Baumanis

BUSINESS DEFINITIONS

CONTRACTOR: A gambler who never gets to shuffle, cut or deal

BUSINESS DEFINITIONS

CONTRACTOR: A gambler who never gets to shuffle, cut or deal.

BID: A wild guess carried out in two decimal places

BUSINESS DEFINITIONS

CONTRACTOR: A gambler who never gets to shuffle, cut or deal.

BID: A wild guess carried out in two decimal places

LOW BIDDER: A contractor who is wondering what he left out

BUSINESS DEFINITIONS

CONTRACTOR: A gambler who never gets to shuffle, cut or deal

BID: A wild guess carried out in two decimal places

LOW BIDDER: A contractor who is wondering what he left out

ENGINEER'S ESTIMATE: The cost of construction in Heaven

BUSINESS DEFINITIONS

CONTRACTOR: A gambler who never gets to shuffle, cut or deal

BID: A wild guess carried out in two decimal places

LOW BIDDER: A contractor who is wondering what he left out

ENGINEER'S ESTIMATE: The cost of construction in Heaven

STRIKE: An effort to increase egg production by strangling the
chicken

BUSINESS DEFINITIONS

CONTRACTOR: A gambler who never gets to shuffle, cut or deal

BID: A wild guess carried out in two decimal places

LOW BIDDER: A contractor who is wondering what he left out

ENGINEER'S ESTIMATE: The cost of construction in Heaven

STRIKE: An effort to increase egg production by strangling the chicken

AUDITORS: People who go in after the war and bayonet the wounded

BUSINESS DEFINITIONS

CONTRACTOR: A gambler who never gets to shuffle, cut or deal

BID: A wild guess carried out in two decimal places

LOW BIDDER: A contractor who is wondering what he left out

ENGINEER'S ESTIMATE: The cost of construction in Heaven

STRIKE: An effort to increase egg production by strangling the chicken

AUDITORS: People who go in after the war and bayonet the wounded

LAWYERS: People who go in after the auditors and strip the bodies

BUSINESS DEFINITIONS

CONTRACTOR: A gambler who never gets to shuffle, cut or deal.

BID: A wild guess carried out in two decimal places

LOW BIDDER: A contractor who is wondering what he left out

ENGINEER'S ESTIMATE: The cost of construction in Heaven

STRIKE: An effort to increase egg production by strangling the chicken

AUDITORS: People who go in after the war and bayonet the wounded

LAWYERS: People who go in after the auditors and strip the bodies

PROJECT MANAGER: The conductor of an orchestra in which every musician is in a different union

CMEP - MODULES

EXPECTATIONS

➤ DEFINE AREAS OF RESPONSABILITY

EXPECTATIONS

- DEFINE AREAS OF RESPONSIBILITY
- IMPROVE DISCIPLINE WORK PROCESS

CMEP – MODULES

EXPECTATIONS

- DEFINE AREAS OF RESPONSIBILITY
- IMPROVE DISCIPLINE WORK PROCESS
- CLAIMS PREVENTION

EXPECTATIONS

- DEFINE AREAS OF RESPONSIBILITY
- IMPROVE DISCIPLINE WORK PROCESS
- CLAIMS PREVENTION
- ADDED VALUE

CMEP – MODULES

TABLE OF CONTENTS

- PRE - AWARD MODULE
 - PRIME CONTRACT
 - Management & Administration
 - Development of flowdown language
 - PARTS III & IV
 - COMMERCIAL CONSIDERATIONS
 - Bonding
 - Insurance
 - Taxes
 - Importation & Customs
 - Incentives/Penalties

CMEP – MODULES

TABLE OF CONTENTS (cont'd)

- PROJECT CONTRACTING PLAN
 - Self Perform or Contract?
 - Constructability
 - Material Responsibility Matrix
 - Schedule review
 - Commercial philosophy
- POTENTIAL CONTRACTS
 - Survey
 - Prequalification
- RFP/CONTRACT DEVELOPMENT SCHEDULE
- RFP KICK OFF MEETING

CMEP - MODULES

TABLE OF CONTENTS (cont'd)

- INDIVIDUAL CONTRACT PLAN

- RFP PREPARATION
 - Nomenclature
 - Responsibility
 - RFP review meeting

- RFP BIDDING PHASE
 - RFP explanation meeting & sitewalk
 - Addendum
 - Proposal opening & distribution
 - Proposal evaluation

CMEP – MODULES

TABLE OF CONTENTS (cont'd)

- POST AWARD MODULE
 - CONTRACT DAILY ACTIVITY REPORT
 - MEETINGS
 - Pre – Construction kick off meeting
 - Progress meeting
 - CONTRACT CHANGES
 - Contract Document Transmittal
 - Contract Site Instruction
 - Contract Modification
 - INVOICE PROCESSING

CMEP - MODULES

TABLE OF CONTENTS (cont'd)

- STATUS REPORTS
- BACKCHARGE ADMINISTRATION
- CLAIMS HANDLING
- CONTRACT CLOSE OUT

CMEP - MODULES

CONTRACTS

PRE – AWARD MODULE

PRIME CONTRACT

- **DEFINITION:** The Contractual Agreement between The Company and the client, that stipulates the roles, responsibilities, and the obligations of each party and the authority of The Company to perform those services.

- **TYPES:** Multiple, including EPC, EPCM, E, PCM, PCP, CP, P, C, etc. Each of these contracting services can be based on a variety of payment methods, e.g., Cost Reimbursable, Lumpsum, Incentive based, etc.

CMEP – PRE – AWARD

PRIME CONTRACT (cont'd)

➤ PROCEDURES:

- Management / Administration
Of the Prime Contract

- Development of flowdown
language

RESPONSIBILITY

Project Manager

Contracts/Legal

CMEP – PRE – AWARD

PRIME CONTRACT (cont'd)

➤ MANAGEMENT/ADMINISTRATION OF THE PRIME

It is the responsibility of the Project Manager to ensure the project is executed in accordance with the terms and conditions as set forth in the Prime Contract.

The Prime Contract can affect the work processes of all project disciplines, it is therefore crucial that the Project Manager makes Prime Contract extracts available for discipline review. The results of the discipline review will be reflected in the Project Procedures and/or “flowdown language”.

PRIME CONTRACT (cont'd)

➤ DEVELOPMENT OF FLOWDOWN LANGUAGE

- DEFINITION: “Flowdown language” is language included within the Prime Contract that is determined by the PCM and the Law Department as language that must be included in any Contract developed between The Company and third party contractor in the performance of any subcontracted work. Areas for which “flowdown language” is typically developed are:
 - Insurance (limits of liability)
 - Indemnity (language)
 - Performance/Payment Bonds

CMEP – PRE – AWARD

PRIME CONTRACT (cont'd)

- DEVELOPMENT OF FLOWDOWN LANGUAGE (cont'd)
 - Prevailing Laws (States or Country of precedence)
 - Use of client products
 - Publicity (limits or restrictions)
 - Taxes, Duties & Fees
 - Guarantees / Warranties
 - Right of audit/Record retention

- RESPONSIBILITY: It is the responsibility of the PCM in conjunction with the Law Department to review the prime contract in order to identify any differences or special requirements that are not included as part of The Company's standard terms and conditions.

CMEP – PRE – AWARD

PRIME CONTRACT (cont'd)

- When the “flowdown language” has been developed, with the formal approval of the Law Department, it shall be submitted to the Project Manager for approval, and the subsequent approval of the client as required. It is then the responsibility of the PCM to ensure the agreed language is incorporated into each Contract issued by The Company.

CMEP – PRE – AWARD

PARTS III & IV

- DEFINITION: PART III is the preprinted form that describes the general conditions and legal terms under which the Work is to be performed.

PART IV is the “Special Terms” that incorporates all changes to PART III as a result of project requirements, e.g. “flowdown language”.

NOTE: PART III cannot be changed or re-written without the approval of the Law Department, and then all changes must be reflected in the PART IV. However, under some circumstances, e.g. The Company in a joint venture partnership, or some International projects, a project specific PART III may be developed.

COMMERCIAL CONSIDERATIONS

➤ Prior to development of the Project Contracting Plan the Project Manager with support from the PCM, the Law Department and The Company Tax and Insurance specialists must determine the Project Philosophy regarding a variety of commercial issues, such considerations may include:

- BONDING
- INSURANCE
- TAXES
- IMPORTATION & CUSTOMS
- INCENTIVE/PENALTIES

CMEP – PRE – AWARD

COMMERCIAL CONSIDERATIONS

BONDING

➤ INTRODUCTION: The Company's policy on risk management requires that risk be reduced, transferred, or eliminated to the greatest extent possible. This is achieved by such methods as irrevocable letter of credit, bank guarantees, bid/payment/performance bonds, and retention.

In the event The Company's client assumes the risk, The Company will make appropriate recommendations to ensure the clients risk is mitigated to the greatest extent possible.

CMEP – PRE – AWARD

BONDING (cont'd)

- A bid bond in the amount of (10%) of the bid price.

NOTE: A bid protects The Company and it's client from any losses should the bidder fail to accept the contract award.

- A separate payment bond in the amount of (100%) of the total award value.

NOTE: A payment bond protects The Company and client from any losses incurred due to a Contractor's default in the supply of labor/or materials.

CMEP – PRE – AWARD

BONDING (cont'd)

- A separate performance bond in the amount of (100%) of the total award value.

NOTE: A performance bond protects The Company and it's client against lass caused by failure of a Contractor's performance of the Work.

- EXCEPTIONS:

At the commencement of and during the life of a project there may be instances where certain risk elements may allow us to eliminate or reduce costly bonding requirements, However, the decision not to bond requires Executive level approval in accordance with Corporate policy

BONDING (cont'd)

➤ EXCEPTIONS (cont'd)

- Contracts less than \$ 100,000 in value
- Cost Reimbursable contracts with an indefinite value that are low risk and therefore may not require a payment/performance bond, in as much as the bonded value is difficult to determine.

CMEP – PRE – AWARD

COMMERCIAL CONSIDERATIONS

INSURANCE

- Certificates of Insurance are required from all The Company Contractors prior to commencement of physical work.

The insurance limits and requirements for each project are established by the Prime Contract. The types and limits of the required insurance will possibly have a cost impact to the bidders, and may also affect whether a company qualifies to bid. Therefore, the bidders must prequalify to those requirements.

- It is the Contract Administrator's responsibility to obtain satisfactory Certificates of Insurance and to ensure they are current through the life of the Contract.

CMEP – PRE -- AWARD

COMMERCIAL CONSIDERATIONS

TAXES

- PART III defines the Contractors responsibilities for the payment of taxes, duties and fees.
- PART IV will define any special tax terms such as tax exemptions the client may qualify for.
- Tax considerations on an overseas project may also affect Project Contracting philosophy, e.g. split Contracts for offshore services (normally supply & fabrication) and onshore services (normally installation). These considerations can yield significant savings for a project.

Each project must develop a strategy for taxes, utilizing the services of The Company tax specialists.

CMEP – PRE – AWARD

COMMERCIAL CONSIDERATIONS

IMPORTATION AND CUSTOMS

- The importation and customs regulations can have significant cost impacts to the project. Client exemptions and qualifications will determine the potential savings, however most exemptions require a high level of administration from The Company and demanding reporting requirements from our Contractors. It is therefore important to establish the procedures early in the project and include the reporting requirements in each appropriate RFP and Contract.

CMEP – PRE – AWARD

COMMERCIAL CONSIDERATIONS INCENTIVES / PENALTIES

- Does the Prime Contract include Incentive/Penalty language? If yes, we should obtain project agreement on how these will be passed on to our Contractor's, if at all.

Timing is of the essence when it comes to the introduction of Incentive or Penalty agreements, in order that maximum benefits are achieved.

Items for consideration are:

- Is the Contractor's scope properly defined?
- Are The Company deliverables confirmed?
- Are there any outstanding items or points of disagreements between The Company and the Contractor that could possibly be resolved as part of an Incentive Agreement?

CMEP – PRE – AWARD

COMMERCIAL CONSIDERATION INCENTIVES / PENALTIES (cont'd)

- Establish the basis of the Incentives, i.e. Safety? Quality? Schedule milestones and/or progress?

➤ Incentive Agreements must be structured for the milestones, etc. to be achievable, i.e. develop a win-win scenario.

An incentive agreement with unachievable milestones will invariably have the reverse affect of what we are trying to achieve.

CMEP – PRE – AWARD

PROJECT CONTRACTING PLAN

- **DEFINITION:** The Project Contracting Plan is the base plan that determines numbers of contracts, schedule of pre-award milestones, and the Contract pricing philosophy.

The Project Contracting Plan will be the basis for the RFP/Contracts Development Schedule and the Individual Contract Plans.

- **RESPONSIBILITY:** The Project Contracting Plan and all subsequent revisions are the responsibility of the PCM, with regard to overseeing, administering and reporting.
- **PROCEDURE:** The Project Contracting Plan must be determined as early in the project as possible. Some of the project options that must be reviewed prior to determining the Contracting Plan are:

CMEP – PRE – AWARD

PROJECT CONTRACTING PLAN (cont'd)

- CONSTRUCTABILITY (cont'd)

- Local infrastructure to support movement of equipment and materials, etc. onto the site.
- Availability of specialized equipment, e.g. Heavy lift craneage.
- Availability of Professional Service.

Contractor's, e.g. Surveying, Soils consultants, NDE, etc.

- COMMERCIAL PHILOSOPHY

- Lump Sum – (Rule of thumb should be if scope is defined at 85%+ Approved for Construction status).

CMEP – PRE – AWARD

PROJECT CONTRACTING PLAN (cont'd)

- Unit Price (Define Units of work, establish the method of measurement, and establish a good estimate, bill of quantities).
- Cost Reimbursable - (Labor, Material and Equipment rates).

SCHEDULE REVIEW

Review project master schedule to assist in decision to Self Perform or Contract, i.e. may identify early activities that do not support establishing The Company indirects onsite to support mobilization of Direct Hire Forces.

CMEP – PRE – AWARD

PROJECT CONTRACTING PLAN (cont'd)

- SCHEDULE REVIEW (cont'd)
 - The master schedule review will assist in identifying the number of contracts, and the initial pricing philosophy.
 - The master schedule will also identify areas for possible horizontal and vertical contract splits.

- MATERIAL RESPONSIBILITY MATRIX
 - The Matrix lists all possible materials.

CMEP – PRE – AWARD

PROJECT CONTRACTING PLAN (cont'd)

- MATERIAL RESPONSIBILITY MATRIX (cont'd)
 - The Matrix assigns the responsibility for procurement of goods and/or services to either Client, The Company Engineering, The Company Construction, 3rd Party Engineering or Contractor.
 - Joint review required with Procurement, Contracts, Engineering, Construction and Projects.
- ✓ **NOTE:** Completing the matrix early in the project will assist in determining the Construction philosophy.

CMEP – PRE – AWARD

POTENTIAL CONTRACTORS

- By performing a survey of potential Contractors the Project Contracting Plan can be finalized. The survey should determine a company's capabilities with regard to technical and execution skills, commercial posture, capacity to meet our requirements, availability of Supervision and equipment, etc.

The following activities are the responsibility of the PCM with assistance from other disciplines as required.

- SURVEY (SOURCES)
 - Previous The Company or Client experience
 - Local Contracting organizations, e.g. ABC, AGC
 - Classified business directories

CMEP – PRE – AWARD

POTENTIAL CONTRACTORS (cont'd)

➤ PREQUALIFICATION

- Issue prequalification questionnaire
- Obtain company standards on Safety and Quality
- Hold "short list" interviews (Include appropriate discipline support)
- Perform evaluation/recommendation for Project Manager and Client approval

CMEP – PRE – AWARD

RFP / CONTRACTS DEVELOPMENT

SCHEDULE

- **DEFINITION:** From the Project Contracting Plan a Project Contract Register/Schedule is developed, which lists each RFP/Contract and identifies milestone activities that must be maintained to meet schedule award dates.

(SEE SAMPLE FORM)

- **RESPONSIBILITY:** The PCM is responsible for developing and maintaining the RFP Register by obtaining input from the discipline Engineering groups on a weekly/monthly basis.

The PCM is responsible for issuing the report in accordance with the Project procedures.

CMEP – PRE – AWARD

RFP KICK – OFF MEETING

- DEFINITION: The RFP kick-off meeting is held for each RFP and will insure timely communication and alignment between Project Management, Engineering, Construction, Project Controls, Contracts and the Client.

The Individual Contracts Plans will be developed at the RFP kick-off meeting.

- RESPONSIBILITY: The PCM is responsible for developing the meeting agenda, chairing the meeting, and issuing/maintaining the Individual Contract Plans. However, it is the responsibility of the Project team to jointly develop each Individual Contract Plan.

CMEP – PRE – AWARD

RFP KICK – OFF MEETING (cont'd)

- PROCURDURE: The purpose of the meeting is to define the following:
 - Major scope items
 - Specific scope exclusions
 - Material responsibilities
 - Scope interfaces
 - Pricing basis
 - Required data for RFP preparation/issue
 - Required data at/after award
 - Engineering data prepared by Contractor
 - General construction execution information
 - RFP preparation schedule

CMEP – PRE – AWARD

RFP KICK – OFF MEETING (cont'd)

- **NOTE:** Latest Engineering progress is reviewed to determine if the initial pricing philosophy is still feasible. If it is no longer feasible the PCM shall issue a revision to the Project Contracting Plan for Project approval. The revision shall identify number, date reason for change and the impact of the change.

CMEP – PRE – AWARD

INDIVIDUAL CONTRACT PLAN

- DEFINITION: The Individual Contract Plan details the specific requirements for each contract, as discussed in the RFP kick-off meeting, such as scope items, listing of materials provided by TRC and Contractor, list of specifications and drawings required for RFP preparation and issue, and RFP preparation schedule, etc.

- RESPONSIBILITY: The PCM shall be responsible for preparation, maintenance and revisions to the Individual Contract Plan. After preparation the PCM shall obtain comments/ approval from all concerned disciplines.

Each revision will be formally issued and signed off by the Engineer, Contracts, and Project Manager.

CMEP – PRE -- AWARD

RFP PREPARATION

➤ NOMENGLATURE:

- INSTRUCTIONS TO BIDDERS: General information standardized at the beginning of the Project and included in each RFP.
- PART I - Scope of Work; General and Specific
- PART II - Commercial Terms
- PART III - Standard Terms and Conditions
- PART IV - Special Terms

- ATTACHMENTS - Project Standard, e.g. Jobsite Safety Requirements

- EXHIBITS - Contract specific, e.g. Equipment list for erection

CMEP – PRE – AWARD

RFP / CONTRACTS DEVELOPMENT

➤ RESPONSIBILITY:

- Many disciplines may be responsible for various of the RFP, however, the PCM is responsible for coordinating those effort and developing the RFP.

➤ RFP REVIEW MEETING:

- It is recommended that an RFP review meeting is held for each major scope of work. The attendees will include all disciplines that have given input, who will review and comment on the draft document prior to finalization and issue for project approval and issue for bidding.

CMEP – PRE – AWARD

RFP BIDDING PHASE

➤ RFP EXPLANATION MEETING AND SITEWALK

- This meeting held at the site with all bidders and attended by all appropriate The Company disciplines is arranged, chaired, and minuted by the Contracts Administrator.
- The purpose of the meeting is to ensure all bidders have a clear understanding of the full scope, advised of any updated information, answer any questions and ensure all bidders are familiar with the site by way of a sitewalk.

CMEP – PRE – AWARD

RFP BIDDING PHASE (cont'd)

➤ ADDENDUM

- The Addendum is used to formally notify the bidders of any revision to the RFP documents, or clarification to general questions from bidders.
- The Addendum is reviewed and approved in similar fashion to the RFP.
- All Addendum's must be referenced with each bidders proposal.

CMEP – PRE – AWARD

RFP BIDDING PHASE (cont'd)

➤ PROPOSAL OPENING & DISTRIBUTION

- The Contracts Administrator is responsible for receiving and dating all proposals.
- The proposal opening must be attended by the Contracts Administrator and at least one other person, in accordance with the Project Procedures.
- Proposal distribution, other than technical, will be made on a need to know basis.

CMEP – PRE – AWARD

RFP BIDDING PHASE (cont'd)

➤ PROPOSAL EVALUATION

- The Contracts Administrator is responsible for coordinating the evaluation effort by distributing and receiving, from all appropriate parties, an evaluation of the parts of the proposal specific to their discipline.

The Contracts Administrator shall assemble all discipline responses, perform the commercial evaluation, and prepare the proposal summary and recommendation.

- Unsolicited proposals will not be accepted.
- All questions and responses must be formally documented.

CMEP – PRE – AWARD

RFP BIDDING PHASE (cont'd)

- The evaluation team will determine a short list if appropriate after the initial screening.
- Proposal Clarification Meetings may be held with the potentially successfully bidder(s), to ensure mutual agreement of scope and proposal prior to finalizing the selection and recommendations.
- Based on the project policy, post bid negotiations may be held with one or more of the bidders prior to final bidder selection. Post bid negotiations must be held in **STRICT** compliance with Project and Company procedures.
- Award recommendations will be made, and approvals obtained, in accordance with project procedures.

CMEP – PRE – AWARD

POST AWARD - MODULE

CMEP – MODULE

How Do We Get New Work?

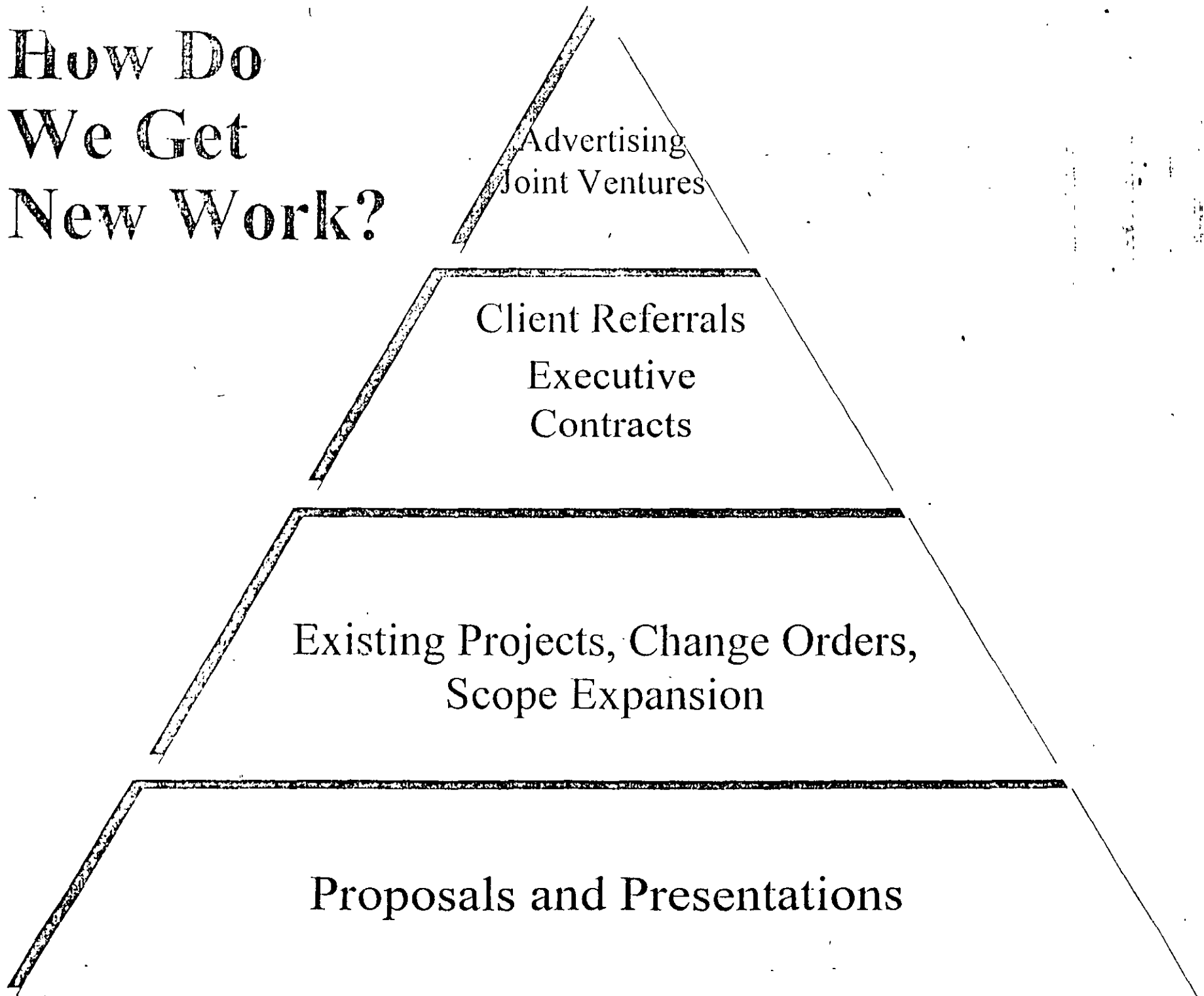

The Three Phases of the Sales Cycle

1. Pre-Proposal Activity

2. Proposal Preparation

3. Post-Proposal Activity

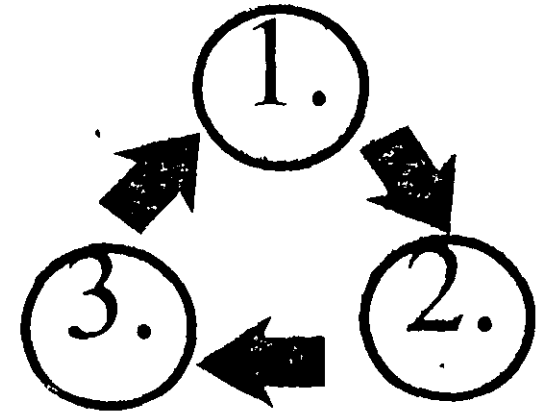

Pre-Proposal Activity

- Intelligence Gathering
- Type of Commercial Offering
- Positioning
- Relationship Building
- Past Customer Relations

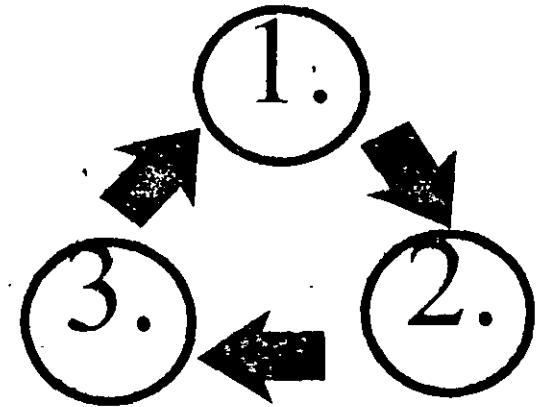

The client relationship which the Procurement Manager develops on an existing project may positively or negatively impact future business with the client.

Proposal Preparation

- Bid / No Bid Analysis and Decision
- Proposal Planning and Preparation
- Proposal Submittal

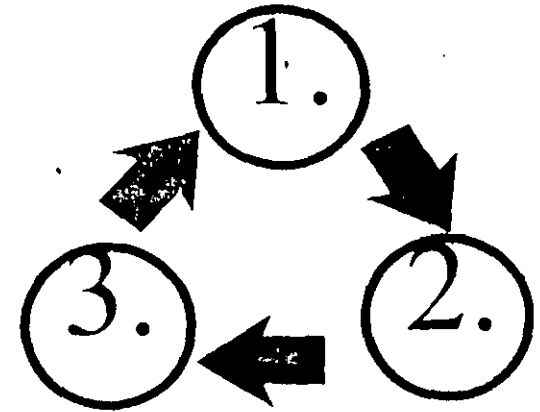

Preparing major proposals is a team process and, particularly where the scope is EPC, Procurement should be a major contributor.

Post-Proposal Activity

- Follow-Up Calls

- Presentations

- Questions and Clarifications

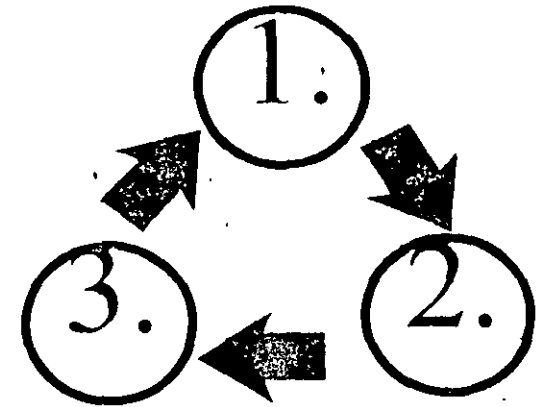

Being able to clearly and concisely present Fluor Daniel's Procurement Capabilities is a vital element for success in certain proposal situations.

Key Elements In The Proposal Process

- ▣ Qualifications Books
- ▣ Proposals
- ▣ Presentations
- ▣ Interviews

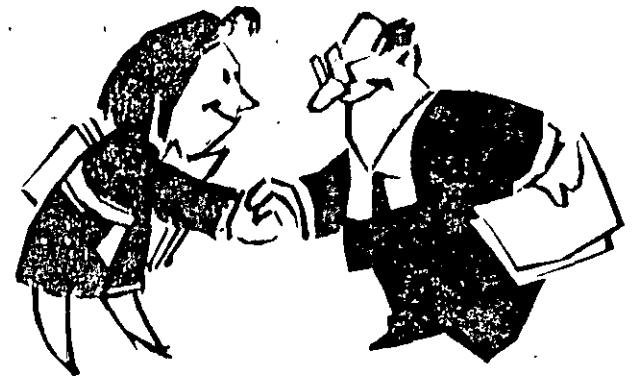
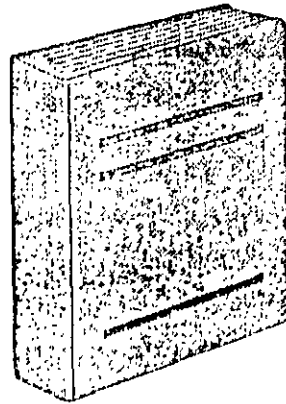
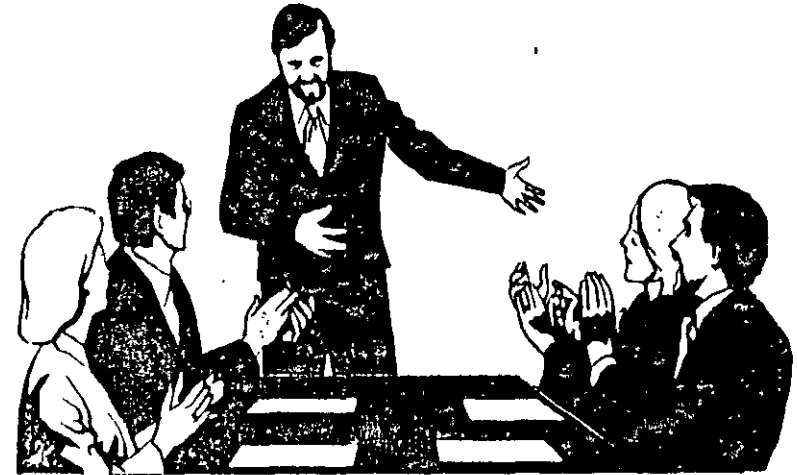

Qualifications Books

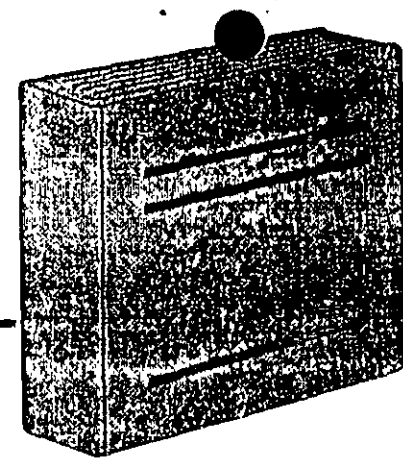

- Give potential clients an overview of Fluor Daniel
- Highlight Fluor Daniel capabilities
- Narrative tends toward "boilerplate", with proposal-specific modifications
- Pricing and "committed" personnel usually not included
- Procurement resumes should be up-to-date and reflect proposal-specific.

Proposals

- Type of Commercial Offering
- Size and detail may vary dramatically
- Content is client or project focused
- Typically include price, commercial terms, resumes and execution plan
- May require soliciting prices on major equipment to help develop Fluor Daniel's proposal to client
- Market intelligence may help shape materials strategy

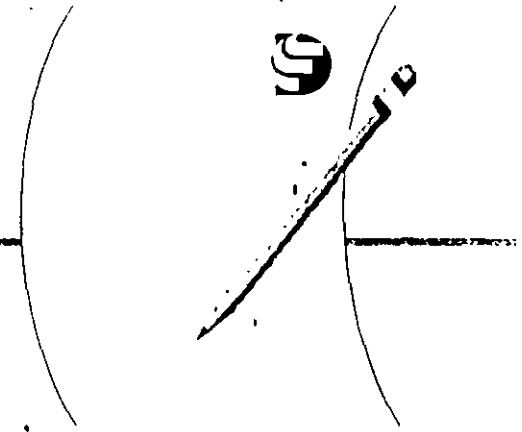

Module Objectives - Project Start-Up

- Understand the PPM roles and responsibilities
- Know the resources available to facilitate good procurement planning
- Understand and incorporate Prime Contract considerations
- Guidelines for developing the project bidders list
- Implementing the procurement systems
- Determine required level of detail for the Activity Plans
- Applying risk management

Project Execution Plan

- Procurement Plans
- Contracting Plan
- Logistics Plan
- Quality Plan

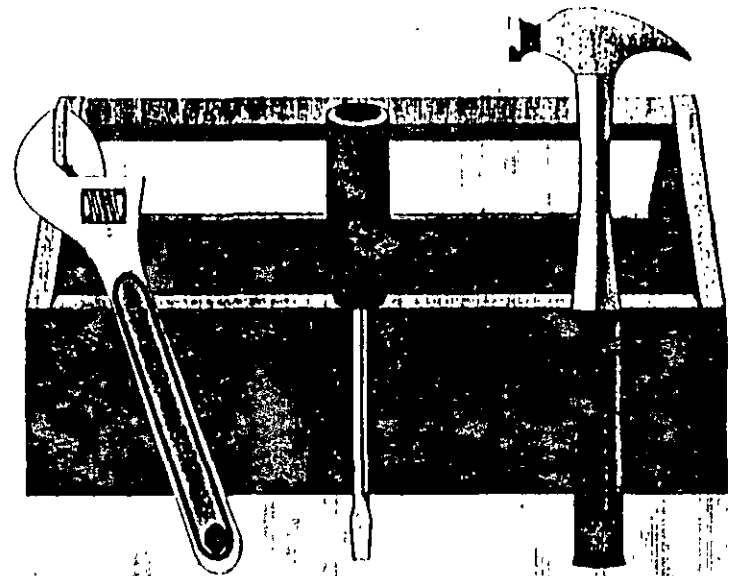

Material and Procurement Plan

1. Purpose
2. Project Definition
3. Material and Equipment
4. Purchasing
5. Contracting
6. Expediting (Home office and shop)
7. Supplier Quality Surveillance
8. Traffic and Logistics
9. Field Purchasing, Warehousing
10. Materials and Procurement Systems
11. Project Procurement Procedure Monitoring

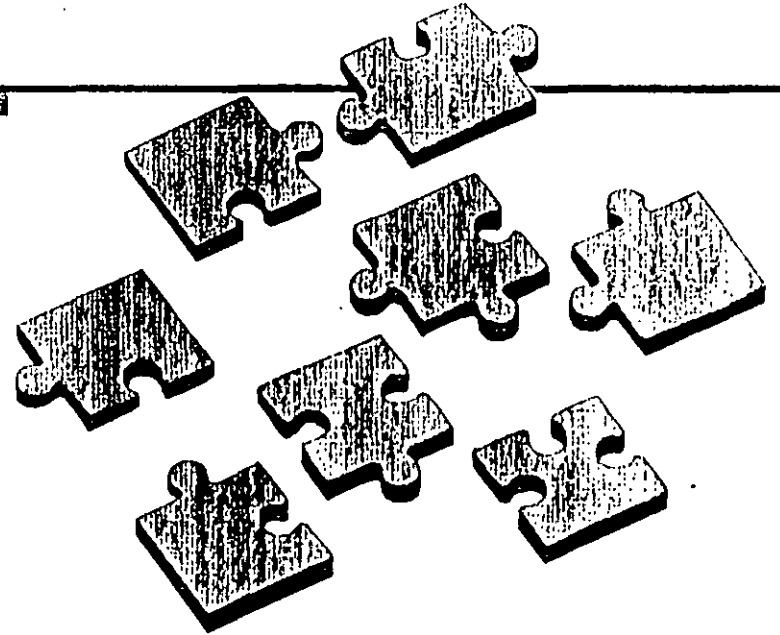

Constructibility

Ability to Influence Final Cost over Project Time

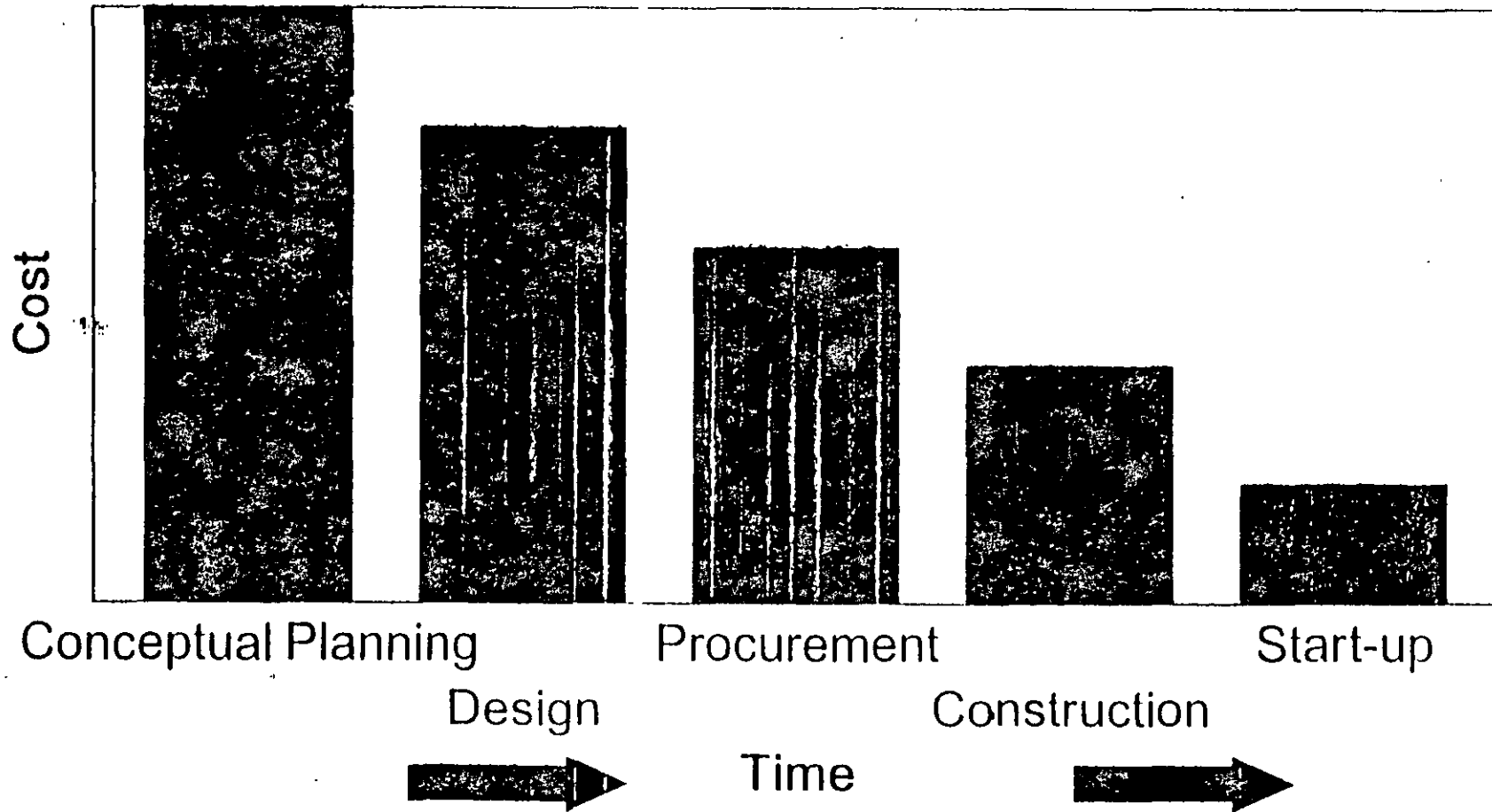

The Starting Point - Procurement Planning

START



Understand the scope and key issues

What are the client expectations and scope of services?

What level of detail of the OPG will be implemented?

Establish objectives (from Client expectations)

Highest Quality?...Lowest possible hours per P.O....Minimal surplus?...accelerated deliveries?

Define roles

Who has responsibility for buying, contracting, reviewing, approving, expediting, surveillance, receiving?

Whose systems will be utilized?

The Starting Point Procurement Planning

START

Incorporate Lessons Learned

How can we apply our experience from other projects and audit findings to enhance performance on this job?

Recognize Constraints

What factors must be accounted for in our execution planning? Prime contract details!

Consider resources

What "tools" are available within Procurement, in other disciplines, in other offices which can be of assistance .

Develop strategies

How can you best meet the identified objectives with the "tools" at your disposal?

PROJECT PROCUREMENT

Organization CHART

(Typical)

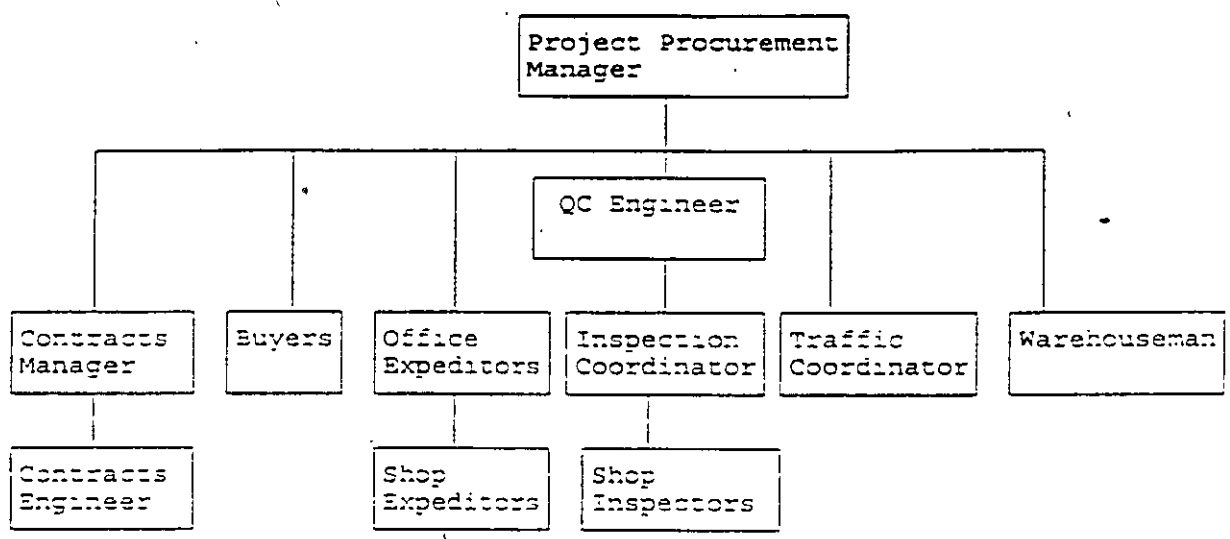

Project Options Checklist

- Define the requirements of prime contract
- Define roles and responsibilities
- Support effort hour estimate



Planning: Prime Contract Review

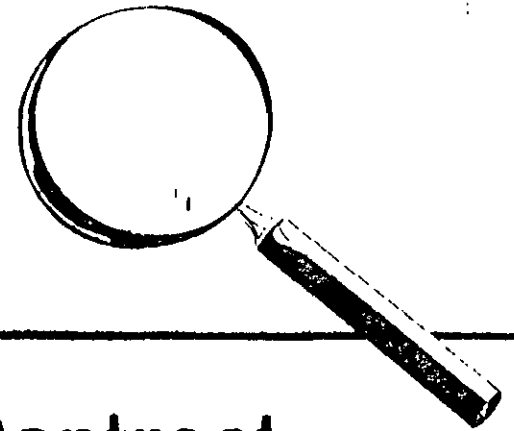

-
- Read and Understand the Prime Contract
 - Essential to Understanding procurement's scope
 - Essential in creating Procurement Documents which reflect the proper Terms and Conditions
 - Assists in understanding the OVERALL project effort
 - Essential in knowing and understanding risks and liability exposure.

Typical Prime Contract Considerations

- What is Fluor Daniel's Procurement/Contracting posture Agent?....Owner?....Contractor?
- Is the project Lump Sum?....Reimbursable cost?...Incentive?
- What, specifically, are Procurement's roles and responsibilities? What are the Procurement deliverables for the job?
- What flowdown provisions (warranties, taxes, insurance, etc.) are contained in the Prime Contract which need to be incorporated in our Procurement documents?
- What are the client's involvement points in document review and approval?
- What are file ownership, transfer, and retention stipulations?
- Licensor Requirements

Project Schedule

- Work with project discipline to understand and monitor schedule objectives and constraints
- Be alert to constructibility issues
- Create a realistic procurement cycle suited for your project
- Identify and make visible critical material plans
- Build a strategy that mitigates projects risks
- Communicate market/supplier trends and current events which may impact your project execution plan
- Determine what are the schedules for document and material tracking, by Procurement or Project Controls?

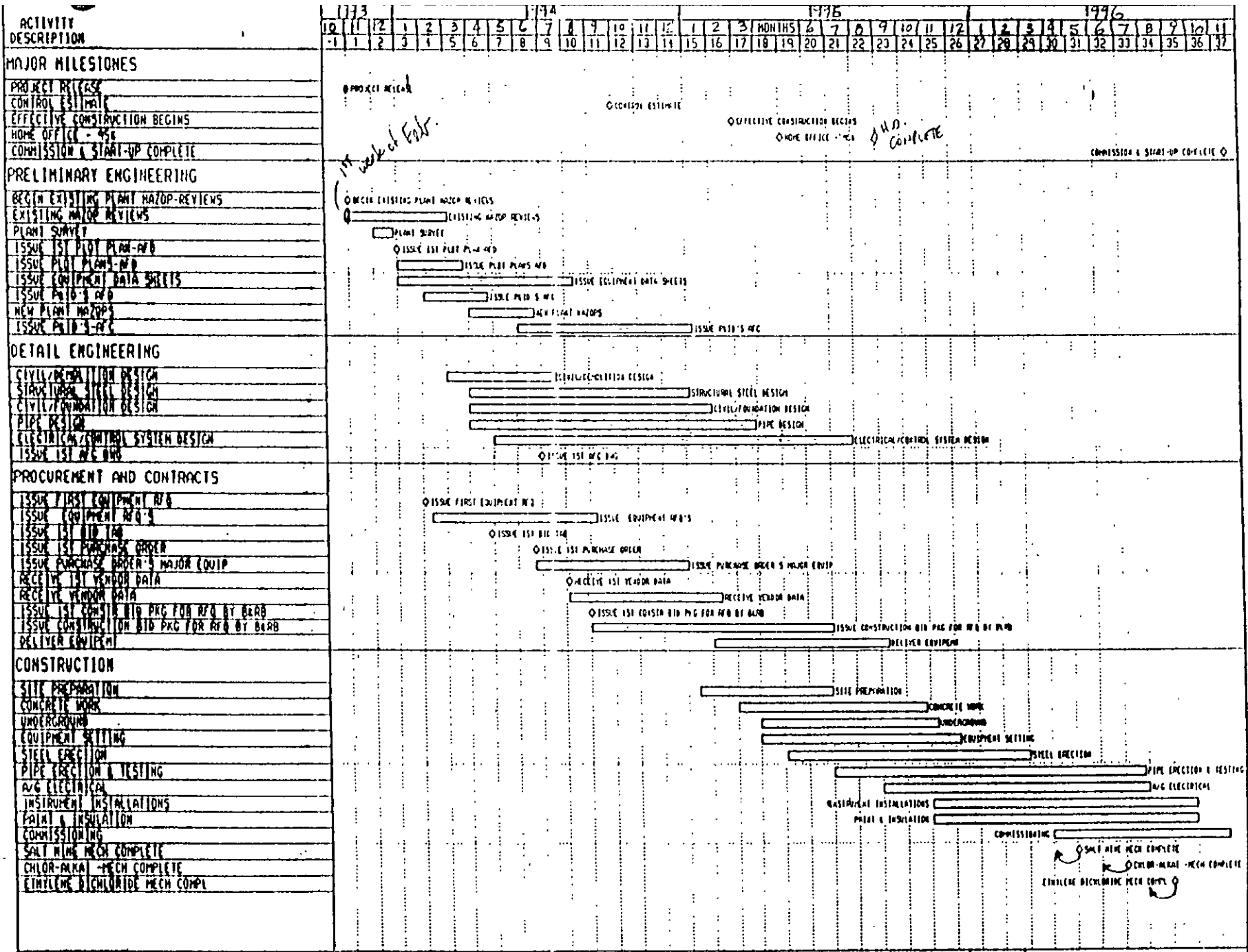

BROWN & ROOT BRAUN/SADAF
MASTER PROJ HEDULE

DATE: _____

BY: _____

DATE	REVISION	DESCRIPTION

Plot Date: 11/20/76
 Plot Name: _____
 Project Start: _____
 Project Finish: _____

Activity: _____
 Physical Activity: _____
 Planning Activity: _____

Critical Materials

- Identify from Several Perspectives
 - Material Lead Time
 - Criticality of Vendor Engineering
 - Constructibility

- Develop a Specific Philosophy/ Procurement Plan, including strategies for schedule enhancement

- Sensitize Project and Procurement Personnel to the Critical Issues

How to Write a Good Procedure

- Material and Procurement Plan and Quality Plan serves as the basis
- Available Tools
 - Procurement Generic Procedures
 - Existing procedures....same Client/Similar Project
 - Procurement Practices Procedure Outline
- Additional Inputs
 - Lessons Learned from Other Projects/Audits
 - Prime Contract flowdown requirements
- Keep it simple and clear

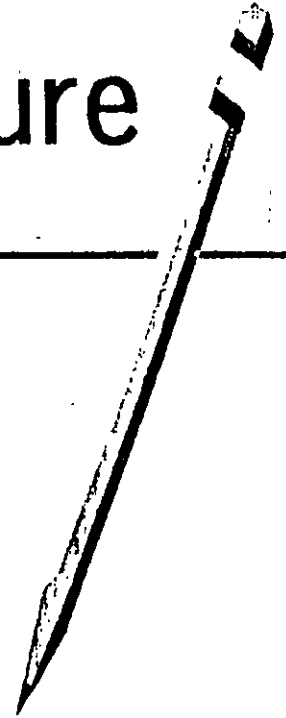

Developing The Project Bidders List

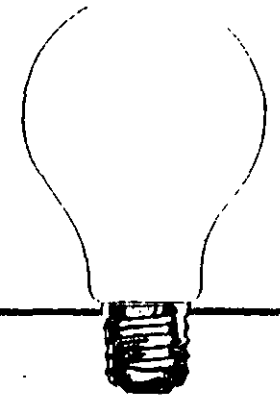

-
- The Supplier Process
 - Key Suppliers
 - Alert/Warning List (000.412.0511)
 - Supplier Evaluations (Lotus Notes)
 - Preferred Suppliers
 - Market Outlook
 - Client Agreements
 - Global Procurement Network
 - Additional Fluor Daniel Resources
 - Client Input
 - Supplier Diversity Program

Staffing Issues

- Plan your manpower to meet the expected workload
- Evaluate the projected work for individual capabilities
- Use effective supervision Techniques and Delegate/Empower!
- Be Alert to Office Support Considerations
- Keep Project, Department Management and Assigned Personnel Informed
- Allow for proper training to Project Specific Requirements as well as personal needs of staff

Applying Risk Management



-
- Protecting the commercial interests of Fluor Daniel and our client..... Managing the controllable variables within the Procurement environment in such a way that risk is minimized.

c/o Foster Wheeler USA Corporation
Perryville Corporate Park
Clinton, New Jersey 08809-4000
Phone 908-730-5438 Fax 908-730-5119

date : 2nd February, 1998
ref : SPMP/FWC L0173

For the attention of

SINCOR PROJECT
CONTRACT NUMBER : C-D-01-1
INVITATION TO TENDER FOR THE
PROCESS AND UTILITIES PACKAGE

Dear Sirs,

This Invitation to TENDER is issued by SINCOR C.A. a company organized and existing under the laws of Venezuela (hereinafter referred to as COMPANY), acting on behalf of :

- Maraven. S.A : 30%
- Norsk Hydro, ASA : 15%
- Statoil Venezuela A.S. : 15%
- Total Venezuela : 40%.

You are invited to submit a TENDER for the engineering, procurement, supply, construction and commissioning of a Process and Utilities Package in the Jose Industrial Complex in Venezuela, as part of COMPANY's Downstream Project (Upgrader), for the manufacture of synthetic crude from the extra-heavy Zuata crude from the Venezuelan Orinoco belt.

Such TENDER shall be submitted in accordance with this Invitation to Tender Letter, and the following documents :

- Instructions to Tenderers
- Form of Agreement, together with
 - Annex 1: Form of Bank Guarantee
 - Annex 2: Form of Final Account Certificate
 - Annex 3: Indemnity and Waiver of Recourse Agreements
 - Annex 4: Liability and Insurance Agreement from Subcontractors
 - Annex 5: Construction All Risks Policy Summary
 - Annex 6: Form of Contractor's Parent Company Guarantee
 - Annex 7: Form of Assignment Agreement
 - Annex 8: Form of Certificate of Endorsement of Design Dossier
 - Annex 9: Form of Interim Certificates
 - Annex 10: Form of Provisional Acceptance Certificate
 - Annex 11: Form of Final Acceptance Certificate
 - Annex 12: Labour Agreement

- Exhibit A: Scope of Work
- Exhibit B: Schedule of Prices
- Exhibit C: Work Time Schedule
- Exhibit D: Performance Guarantees
- Exhibit E: Design Dossier
- Exhibit F: Particular Conditions for Performance of the Work
- Exhibit G: Co-ordination Procedure
- Exhibit H: Quality Assurance and Quality Control
- Exhibit I: Company Items
- Exhibit J: List of Subcontractors and Vendors
- Exhibit K: Contractor's Organisation and Key Personnel
- Exhibit L: Health, Safety and Environment
- the DESIGN DOSSIER documents which are contained in separate volumes.

One set of the above documents is provided, and a further set will be forwarded to you by the 5th February, 1998.

TENDERERS are requested to submit their TENDERS as described in the attached "Instructions to Tenderers", so that they arrive at the address stated in the "Instructions to Tenderers" by not later than 12:00 hours, local (New Jersey) time, on the 15th May of 1998.

The Form of Acknowledgement, Appendix 1 of the Instructions to Tenderers, shall be returned within three (3) days confirming your intention in response to this Invitation to Tender.

Yours faithfully,

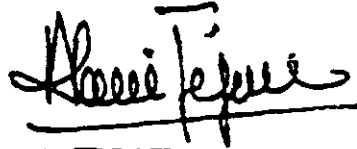

A. JEGOU
Project Director

SINCOR

INVITATION TO TENDER

CONTRACT NO C-D-01-1

FOR THE

**ENGINEERING, PROCUREMENT, SUPPLY, CONSTRUCTION
AND COMMISSIONING**

OF THE

PROCESS AND UTILITIES PACKAGE

SINCOR PROJECT CONTRACT NO C-D-01-1

LIST OF CONTENTS

INSTRUCTIONS TO TENDERERS

FORM OF AGREEMENT

ANNEX 1: FORM OF BANK GUARANTEE

ANNEX 2: FORM OF FINAL ACCOUNT CERTIFICATE

**ANNEX 3: INDEMNITY AND WAIVER OF RECOURSE
AGREEMENTS**

**ANNEX 4: LIABILITY AND INSURANCE AGREEMENT FROM
SUBCONTRACTORS**

ANNEX 5: CONSTRUCTION ALL RISKS POLICY SUMMARY

**ANNEX 6: FORM OF CONTRACTOR'S PARENT COMPANY
GUARANTEE**

ANNEX 7: FORM OF ASSIGNMENT AGREEMENT

**ANNEX 8: FORM OF CERTIFICATE OF ENDORSEMENT OF
DESIGN DOSSIER**

ANNEX 9: FORM OF INTERIM CERTIFICATES

ANNEX 10: FORM OF PROVISIONAL ACCEPTANCE CERTIFICATE

ANNEX 11: FORM OF FINAL ACCEPTANCE CERTIFICATE

ANNEX 12: LABOUR AGREEMENT

- **EXHIBIT A: SCOPE OF WORK**
- **EXHIBIT B: SCHEDULE OF PRICES**
- **EXHIBIT C: WORK TIME SCHEDULE**
- **EXHIBIT D: PERFORMANCE GUARANTEES**
- **EXHIBIT E: DESIGN DOSSIER**
- **EXHIBIT F: PARTICULAR CONDITIONS FOR PERFORMANCE
OF THE WORK**
- **EXHIBIT G: CO-ORDINATION PROCEDURE**
- **EXHIBIT H: QUALITY ASSURANCE AND QUALITY CONTROL**
- **EXHIBIT I: COMPANY ITEMS**
- **EXHIBIT J: LIST OF SUBCONTRACTORS AND VENDORS**
- **EXHIBIT K: CONTRACTOR'S ORGANISATION AND KEY
PERSONNEL**
- **EXHIBIT L: HEALTH, SAFETY AND ENVIRONMENT**

**SINCOR PROJECT
CONTRACT NO C-D-01-1
PROCESS AND UTILITIES PACKAGE**

SECTION A - COMMERCIAL PROPOSAL

The Commercial Proposal shall be initialled in blue ink on every page and signed by an officer of TENDERER vested with authority to commit TENDER.

The Commercial Proposal shall comprise the following :

A.1 COVER LETTER

This section shall contain the TENDER cover letter written upon TENDERER's letterhead.

A.2 FORM OF TENDER

This section shall contain the completed Form of Tender in accordance with Appendix 4 hereof.

A.3 PRICE

A.3.1 Exhibit B

This section shall contain EXHIBIT B, with TENDERER's proposed rates, sums and prices inserted therein.

Computer diskettes (Microsoft Word for Windows, version 6.0) are enclosed (in Attachment K, of EXHIBIT B) to assist you in the preparation of your TENDER. You are requested to insert your proposed rates, sums and prices, but to make no other textual amendments to this document.

A.3.2 Unit rates, EXHIBIT B, Attachment F

Within Attachment F of EXHIBIT B, TENDERER is requested to insert his proposed unit prices to be applicable in the event of changes to the WORK arising from CHANGE ORDERS.

Within Attachment F of EXHIBIT B, TENDERER shall also submit his proposed pricing conditions :

- adapted to the specific technical requirements of the WORK,
- defining the content of each of the unit rates (e.g. "rates for concrete are inclusive of formwork and reinforcement")
- for all trade disciplines.

A.3.3 Subdivision of the WORK for tax purposes

TENDERER shall note that, for tax purposes, upon the award of any CONTRACT it is COMPANY's intention to split the WORK between its onshore and offshore elements. This will necessitate entering into :

- a "master" contract covering the overall scope of WORK, which would be the reference document with regard to any eventual disputes between the PARTIES,
- a contract for the onshore portion of the WORK,
- a contract for the offshore portion of the WORK,

and the rates, sums and prices within EXHIBIT B have been split according to the above principle.

SINCOR PROJECT
CONTRACT NO C-D-01-1
PROCESS AND UTILITIES PACKAGE

TENDERER's proposed lump sum price shall be inclusive of all taxes, with the exception of Venezuelan Value Added Tax (see item A.3.4 below) and Customs Duties (see item A.3.6 below). Municipal Taxes shall be priced upon the basis of item A.3.5 below.

TENDERER's proposed rates, sums and prices shall be deemed to take into account the tax advantages of the above mechanism.

TENDERER's proposed rates, sums and prices are deemed to be inclusive of any and all additional costs associated with the above mechanism including, but not limited to :

- costs associated with the establishment of the additional contractual instruments,
- invoicing costs,
- logistical costs.

TENDERER shall, based upon his knowledge of the Venezuelan taxation laws and experience of working in Venezuela, submit a detailed proposal for minimising the impact of taxation in accordance with the above principles, and upon which his submitted rates, sums and prices are based.

A.3.4 Value Added Tax

In respect of any Value Added Tax chargeable in Venezuela upon any goods supplied or services rendered by CONTRACTOR hereunder, COMPANY shall reimburse CONTRACTOR for such Value Added Tax at cost in accordance with the applicable laws, decrees and regulations.

TENDERER's proposed rates, sums and prices in EXHIBIT B shall be exclusive of all Venezuelan Value Added Tax, but inclusive of all other Value Added Tax.

A.3.5 Venezuelan Municipal Taxes

In respect of Venezuelan Municipal Taxes, TENDERER shall base his proposed rates, sums and prices upon the assumption that Municipal Taxes shall only apply to subcontract construction WORK on SITE and at a rate of three percent (3%), and shall within his TENDER state the portion of the lump sum price, item 4 of EXHIBIT B, which is inclusive of such Venezuelan Municipal Taxes.

The rates, sums and prices stated in EXHIBIT B shall then be adjusted according to the actual rate of Municipal Tax eventually agreed between COMPANY/CONTRACTOR and the applicable authority.

In arriving at his proposed rates, sums and prices in EXHIBIT B, TENDERER shall also take into account the normal practices within Venezuela, and his previous experience in respect of the application of Municipal Taxes.

A.3.6 Customs Duties

TENDERER's proposed rates, sums and prices stated in EXHIBIT B shall be based upon the principle that customs duties for the importation of CONTRACTOR ITEMS, ASSIGNED COMPANY ITEMS and other COMPANY ITEMS imported into Venezuela in relation with the performance of the WORK, shall be paid by COMPANY directly to the customs authorities.

TENDERER is deemed to be aware of all applicable laws regarding the importation of items into Venezuela, including the Venezuelan "A/B/C" categorisation procedure.

SINCOR PROJECT
CONTRACT NO C-D-01-1
PROCESS AND UTILITIES PACKAGE

TENDERER shall provide, where requested in EXHIBIT B, a detailed list of all items to be imported into Venezuela and corresponding value of each item included in the lump sum price to enable COMPANY to evaluate the amount of the import duty in respect of the TENDER evaluation and of CHANGE ORDERS relating to any onshore-to-offshore shifts of the WORK.

Subject to APPROVAL, CONTRACTOR may shift WORK from onshore to offshore, in which case the additional import duty resulting from such shift shall be to CONTRACTOR's account.

A.3.7 Alternative for lump sum price all in US\$

EXHIBIT B, item 5 provides for TENDERER to submit his proposal for the Alternative lump sum price which would apply should the entire lump sum price, both onshore and offshore, be in US\$.

A.3.8 LONG LEAD ITEMS

COMPANY's initial Contracting philosophy was that COMPANY would issue the calls for tender for the Long Lead Items (see following table) and proceed with the evaluation and placement of the Purchase Orders, and that such Purchase Orders would be then assigned to CONTRACTOR.

PURCHASE ORDER NUMBER	DESCRIPTION OF EQUIPMENT
P-111	Crude column
P-101	Vacuum column
P-107	Crude charge heaters
P-127	Vacuum charge heaters
P-118	Crude charge pumps
P-119	Crude booster pumps
P-128	Reaction heater
P-121	Washing naphtha pump
P-129	Cold reactor F/E exchanger
P-130	Hot reactor F/E exchanger
P-131	Naphtha F/R effluent exchang
P-132	Naphtha pre-heater
P-133	Reactor effluent S/T feed exchanger
P-134	Reactor F/E exchanger
P-135	Recycle preheater
P-145	Reactor heaters
P-116	H2 Recycle compressor
P-106	Recycle compressors
P-115	Combined H2 M/U compress
P-122	Naphtha feed pumps
P-123	Gasoil feed pumps
P-124	Feed pump
P-125	Washing water pump
P-113	Dedienisation reactor
P-103	1st reactor train 1

**SINCOR PROJECT
CONTRACT NO C-D-01-1
PROCESS AND UTILITIES PACKAGE**

P-103	1st reactor train 2
P-104	2nd reactor train 1
P-104	2nd reactor train 2
P-105	HDS reactor
P-146	Stripper F/E exchanger
P-109	Utility boilers
P-143	Sulphur forming unit
P-110	*DCS system

It is now COMPANY's requirement that TENDERER/CONTRACTOR shall take all commercial and technical responsibility for issuance of calls for tender, evaluation and award of the long lead item Purchase Orders as with all other items of materials and equipment to be supplied by CONTRACTOR (*with the exception of the DCS which will remain a COMPANY ITEM and eventually become an ASSIGNED COMPANY ITEM).

However, COMPANY has to a varying extent proceeded with the tender evaluation for these items, and should TENDERER consider that a review of the original inquiry documents and technical proposals submitted by the Bidders would be of assistance in the preparation of his TENDER, he shall be entitled to peruse such documents at COMPANY's offices at the address stated in item 4.7 above, and arrangements shall be made through the Process and Utilities Package Project Manager, Mr de Chezelles, in this respect.

It shall be understood, that such documents are available for information purposes only, and TENDERER shall decide whether or not to make use of their contents in the preparation of his TENDER, and shall take full responsibility for same.

A.3.9 ASSIGNED COMPANY ITEMS

A.3.9.1 Article 10.2 of the AGREEMENT provides for COMPANY to assign all Purchase Orders in respect of the COMPANY ITEMS listed in EXHIBIT I to CONTRACTOR.

Attachment B of EXHIBIT B comprises the build up of a Provisional Sum in respect of such ASSIGNED COMPANY ITEMS.

COMPANY has stated estimated values for the related Purchase Orders, and TENDERER is required to insert his proposed prices for all costs associated with taking over of the Purchase Orders, including but not limited to management, engineering (including the impact of engineering development), procurement, supply, construction and installation and commissioning, any necessary temporary storage at quayside Jose, Venezuela, and transportation from quayside to SITE, and including all of the costs stated in Article 30.4 of the AGREEMENT.

COMPANY has initiated the calls for tender for the above Purchase Orders and it is COMPANY's intencion to perform the evaluation and full clarification of the associated bids in order to arrive at a selected bidder for each Purchase Order. Following award of the respective Purchase Orders COMPANY would then assign the Purchase Orders to CONTRACTOR as soon as possible following award of the present EPSCC CONTRACT. The CONTRACT PRICE would then be adjusted in accordance with the mechanism set out in item 3 of EXHIBIT B.

SINCOR PROJECT
CONTRACT NO C-D-01-1
PROCESS AND UTILITIES PACKAGE

A.3.9.2 COMPANY may alternatively, at COMPANY's sole option and schedule-permitting, hand over the draft Purchase Orders relating to 2 shortlisted bidders to TENDERER in order that TENDERER may incorporate the COMPANY ITEMS within his TENDER prior to any award of the present EPSCC CONTRACT.

A.3.10 Split between Process and Utilities

COMPANY reserves the right to award the Process portion of the PLANT to one CONTRACTOR, and the Utilities portion to another.

In submitting his TENDER, TENDERER is deemed to accept this principle.

Item 4, and Attachment A.2 and A.3, of EXHIBIT B provide for TENDERER to submit his proposed prices to be applicable in such event.

A.3.11 "Blanket Orders"

In order to ensure uniformity throughout the PROJECT, COMPANY will pre-select specific VENDORS for the supply of certain items of equipment and materials. The list of such items of equipment and materials is contained within EXHIBIT J, Attachment J.2, and TENDERER shall proceed with the preparation of his TENDER upon the basis that the restriction to a specific VENDOR does not apply. Prior to any CONTRACT award, COMPANY will inform TENDERER of the name of each of the respective VENDORS selected by COMPANY, and TENDERER shall incorporate this requirement within his TENDER.

A.3.12 COMPANY's take-off

For the purposes of the preparation of COMPANY's estimate of the PROJECT cost, COMPANY has produced a take-off of the approximate quantities of the major material and equipment requirements.

Should TENDERER consider that a review of such document would be of assistance in the preparation of his TENDER, he shall be entitled to peruse such documents at COMPANY's offices at the address stated in item 4.7 above, and arrangements shall be made through the Process and Utilities Package Project Manager, Mr de Chezelles, in this respect.

It shall be understood, however, that this document is available for information purposes only, and TENDERER shall decide whether or not to make use of its contents in the preparation of his TENDER, and TENDERER/CONTRACTOR shall not be entitled to any compensation whatsoever in respect of any difference between the quantities stated in the take-off document and the actual quantities required.

A.4 LEGAL AND FINANCIAL STATUS

This section shall contain :

- TENDERER's name.
- Corporate ownership details and legal status.

**SINCOR PROJECT
CONTRACT NO C-D-01-1
PROCESS AND UTILITIES PACKAGE**

- Country of incorporation.
- Country of residence for tax purposes.
- Major activities.
- Names of principal officers.
- Corporate organisation charts.
- Bank references.
- Financial reports for the last five years (the most recent report shall have been issued a maximum of 6 months earlier)
- Statement that Tenderer is familiar with all government and local regulations.
- Details of any outstanding, or potential, litigation against TENDERER which could have an adverse impact upon the WORK.
- Details of any outstanding indebtedness or unsecured loans or debts or trading losses not reported within the financial reports.

A.5 JOINT VENTURE

If applicable, this section shall contain the Joint Venture documents and statements described in item 4.13 above.

A.6 PARENT COMPANY GUARANTEE

In the event that TENDERER is a subsidiary of another Company or Corporation, or is more than 50% owned by another Company or Corporation, it is a condition precedent to the acceptance of any TENDER that the TENDERER's ultimate holding Company provides a 'Parent Company Guarantee' letter in the form of Appendix 2 hereof, which is to be signed by an officer(s) vested authority to commit the parent company.

In the case of a Joint Venture a Parent Company Guarantee shall be provided by each Joint Venture Partner.

A.7 BID BOND

TENDERER shall within this section, provide COMPANY with a Bid Bond in the form of a bank guarantee issued by a bank acceptable to COMPANY, and in the format of Appendix 3 hereof.

The Bid Bond shall be in the amount of \$2,000,000 (two million United States Dollars) and it shall be valid for a period of 150 (one hundred and fifty) days (being the TENDER validity period plus 30 days) from the date stated for submission of the TENDER in the Invitation to Bid covering letter.

The Bid Bond shall become the property of COMPANY and COMPANY shall have the right to submit forthwith TENDERER's Bid Bond for payment if the said TENDERER withdraws his offer during the period of validity and/or, having been awarded the CONTRACT, withdraws or is unable to implement it.

The Bid Bond validity period shall be extended if so requested by COMPANY.

A.8 BANK CERTIFICATE

This section shall contain a certificate issued by a leading Bank in which said Bank commits itself, in case of award of the CONTRACT, to furnish the necessary Bank Guarantee as defined in the AGREEMENT and complying with the model within Annex 1 to the AGREEMENT.

**SINCOR PROJECT
CONTRACT NO C-D-01-1
PROCESS AND UTILITIES PACKAGE**

A.9 ALTERNATIVES

TENDERER shall submit in the format of the following tabulation the impact of any Alternatives proposed by TENDERER, clearly cross-referenced to the items within section B.26 of the TENDER.

SECTION B - TECHNICAL PROPOSAL

TENDERER shall submit as much technical data, execution plans, procedures and organisational and personnel information as necessary for COMPANY to fully understand and evaluate TENDERER's Technical Proposal and his understanding of the TENDER DOCUMENTS.

The Technical Proposal shall comprise the following :

B.1 COVER LETTER

This section shall contain the TENDER cover letter written upon TENDERER's letterhead.

B.2 PROJECT MANAGEMENT

This section shall comprise :

- A clear description of the proposed coverage of co-ordination and interfaces between engineering, procurement, construction, installation, pre-commissioning and commissioning.
- The organisation charts for each phase of the CONTRACT, including management, reporting, engineering, procurement, construction supervision, installation, pre-commissioning, commissioning, safety, and quality control. The Organisation Charts shall identify the Project Personnel according to the TENDERER's standard classification. Such identification shall also be used for EXHIBIT B - Time rates. The main categories of personnel identified in EXHIBIT B shall also be used to identify the key personnel.
- The list of Key Personnel which would be committed to the CONTRACT (in accordance with EXHIBIT K) together with the associated resumes. The nominated personnel shall be capable of constituting a team of compatible, motivated, qualified and experienced personnel of the appropriate skill-mix.

B.3 PLANNING AND SCHEDULING

This section shall comprise :

- TENDERER's proposed Preliminary Work Time Schedule being a time based, logic-linked bar chart presented in accordance with the Level 1 schedule requirements set out in EXHIBIT G, and showing a total of not less than 100 activities and covering the entire period of the WORK, incorporating :
 - the assumed EFFECTIVE DATE and major Milestones, stated in EXHIBIT C,
 - all engineering, procurement, fabrication, erection, construction, precommissioning and commissioning activities for all major elements,
 - main interfaces with other contractors.
- EXHIBIT C, with TENDERER's proposed Milestone dates inserted where requested.
- TENDERER's proposed time-scaled manpower histogram for each phase of the WORK.

SINCOR PROJECT
CONTRACT NO C-D-01-1
PROCESS AND UTILITIES PACKAGE

- Identification of any long lead items (defined as having a delivery time of 14 months or more) as well as the schedule for placement of orders for these items to meet the overall time schedule.
- TENDERER's planning and progress control procedures, including services to be provided, description of planning and scheduling organisation and duties of nominated personnel, interfaces with other functions, etc.
- Detailed progress measurement formulae/mechanism for determining the progress achieved in respect of the engineering, procurement, construction and commissioning phases of the WORK. Such formulae/mechanism shall be based upon the principles set out in EXHIBIT G.
- A set of physical progress curves planned by TENDERER for engineering, purchasing, deliveries and construction phases of the WORK.

B.4 COST CONTROL

This section shall comprise TENDERER's cost control proposals covering :

- Final cost forecasting, commitments follow-up,
- Progress reporting, based on physical progress, including proper identification of outstanding works,
- Description of Proposed method for handling changes in the work.
- Detailed procedure for cost control and reporting (within CONTRACTOR's organisation, and for that which will be passed on to COMPANY) including sample formats.

B.5 REPORTING

This shall comprise sample formats relating to project reporting, including format :

- monthly and weekly progress reports
- purchase status and material status reports
- HSE reports
- planning, scheduling and cost control reports.
- quality assurance and quality control reports.

B.6 HEALTH, SAFETY AND ENVIRONMENT PLAN

Within this TENDERER shall provide its plan for ensuring that the CONTRACT requirements for health, safety and the environment as set out in EXHIBIT L are met throughout the engineering, procurement, construction, installation, precommissioning and commissioning of the WORK.

TENDERER shall provide his health, safety and environment policy and procedures applicable to the design and construction phases and plan for design and construction safety reviews and control.

**SINCOR PROJECT
CONTRACT NO C-D-01-1
PROCESS AND UTILITIES PACKAGE**

B.7 QUALITY MANAGEMENT PLAN

TENDERER shall include with this section the following documents :

- Quality Assurance Plan: A representative Quality Assurance Plan or outline of a Quality Plan which describes the organisation and procedures to be used for control of the WORK, and how compliance with the requirements of the CONTRACT will be achieved. TENDERER shall also submit a description of the Procedure to be established for updating such Plan.
- Qualifications of QA/QC and Inspection Personnel: The minimum education, training and experience for each proposed position within the QA/QC and inspection organisation along with an evaluation of the number and duration of all QA/QC positions required for the WORK.
- A preliminary QA Programme.
- A plan for approving welding procedures and welder qualifications.
- TENDERER's Quality Manual including corporate objectives and policy statements, and covering :
 - QA/QC organisation and personnel.
 - Control of engineering and design, including design change control and control of VENDOR documentation.
 - Qualification of VENDORS and SUBCONTRACTORS.
 - Control of WORK by VENDORS and SUBCONTRACTORS, including audits of quality assurance systems and procedures and identification and control of non-conformance.
 - Positive material identification, alloy verification.
 - Quality Control inspection of equipment, materials and field construction.
 - Preservation, packing and long term storage of equipment and materials.
 - Other aspects of QA/QC.

TENDERER shall identify all VENDORS where it intends to have representatives upon a part-time or full time assignment basis. TENDERER shall submit a tentative program/schedule for this WORK.

B.8 COMPUTER SYSTEMS

TENDERER shall provide full details of the extent to which CAD is proposed to be used for the WORK.

TENDERER shall provide the following details of its in-house computer facilities and software applications, clearly indicating its capacity, and previous experience and that of its personnel in the various applications.

- Computer Facilities : a detailed description of the computer facilities envisaged for the WORK. The information shall include the type, manufacturer, size, capacity and description, as applicable.
- Software applications : TENDERER shall provide detailed information on all software applications that it plans to use for the WORK.
- Information Management : TENDERER shall provide details on how it intends to manage and control electronic data to ensure integrity and to maximise its availability to all users throughout all phases of the WORK.

**SINCOR PROJECT
CONTRACT NO C-D-01-1
PROCESS AND UTILITIES PACKAGE**

- Integration and Transfer: TENDERER shall provide details on the amount of integration of the above systems and the ability to transfer data between systems.
- TENDERER shall confirm that its system can handle the conversion to AUTOCAD 13.

B.9 WORK EXECUTION PLAN

TENDERER shall submit a comprehensive write-up on how he intends to execute the WORK, clearly identifying the sources of technical data and methodology of design, codes, standards and specifications and procedures to be applied to all phases of the WORK.

The Execution Plan shall include :

- Source of technical data and general engineering information for each major area or discipline.
- Comprehensive listing of codes, standards, specifications and procedures to be used for the execution of the WORK.
- TENDERER's selected design approach in the event that the Basic Engineering Package indicates any optional work.

B.10 ENGINEERING

This shall comprise :

- Details of approach to engineering management including interfaces between disciplines.
- Description of TENDERER's design and engineering procedures
- Plans for safety and technical reviews.
- Description of drawing and document control system, with samples, which the TENDERER proposes to use for the WORK.
- Plan for co-ordination of multi-location activities and for communications between locations including spoken, drawings, documentation and electronic data.
- Procedure for material take-off and spare parts recommendation.
- Procedure for incorporating safety into the PLANT design, including design safety policy and safety reviews.
- Plan for mobilisation to ensure fast start of engineering activities.
- Proposed handover plan including system definition and documentation.
- Plan for expediting and quality control of SUBCONTRACTOR, including VENDOR, engineering.
- Scope of SUBCONTRACTOR's and VENDOR's engineering. TENDERER shall define to which extent CONTRACTOR will complete drawings and specifications for items such VENDOR engineered packages, and piping fabrication, and to which degree will SUBCONTRACTOR's or VENDOR's engineering be reviewed for such items.
- Copy of each standard form, chart or list which TENDERER proposes to use for the WORK, with a description of its functions and relationship within the engineering procedure.

**SINCOR PROJECT
CONTRACT NO C-D-01-1
PROCESS AND UTILITIES PACKAGE**

B.11 PROCUREMENT

This shall comprise :

- proposed procedures for purchasing and material control of CONTRACTOR-furnished materials including warehousing, receipt, storage and issue of materials.
- Approach for ordering and controlling procurement, including interface arrangements between procurement and engineering activities.
- Strategy for purchasing equipment, materials and services in Venezuela and estimated Venezuelan content.
- TENDERER's procedure for assessing manufacturers' capability and capacity and for maintaining up-to-date VENDOR list.
- Material sourcing plan which describes the following:
 - Whether material will be imported or procured locally.
 - Name and location of material vendor.
 - Procurement lead time for each material; the above material sourcing plan shall include the direct materials and consumables such as explosives, detonators, etc..
- Expediting plan including vendor data.
- Inspection and testing plan.
- Sample forms.
- TENDERER's organisation and procedures for purchasing, expediting and inspection of equipment, materials and spare parts, and for material control in the field and module fabrication yards.
- Plan for standardisation of materials.

B.12 CONSTRUCTION

This shall comprise :

- Mobilisation plan for construction personnel, construction equipment, temporary facilities, etc.
- Logic and sequence of construction activities in different areas, in particular in relation to modularisation, and heavy transportation and erection.
- Total construction manhours together with the manpower loading (direct labour) and staff loading (indirect labour) for the duration of the WORK and the entire construction schedule.
- Availability and source of manpower resources needed, including separate histograms on a month by month basis for supervisory and administrative personnel, subcontract personnel, craft personnel, VENDOR service representatives, engineers, home office personnel visiting the SITE.
- Plan for early establishment of temporary construction facilities including access by sea and by road, camp and related utilities.
- Temporary facilities envisaged and their layout, outline of storage facilities to be used, type of warehouse and size, yard and laydown area, customs receiving area, etc., including haul roads, lighting, underground services, drainage, material storage, equipment maintenance facilities, buildings, offices, laydown, storage, material offloading, power and water facilities.
- Labour training.
- SITE Security in relation to the WORK performance.
- Safety, including policy, procedures, audits relating to CONTRACTOR and SUBCONTRACTORS.

SINCOR PROJECT
CONTRACT NO C-D-01-1
PROCESS AND UTILITIES PACKAGE

- Industrial relations plan/strategy.
- Training organisation.
- List of construction equipment proposed and source of equipment.
- Field material control.
- Any proposals for free-issue by CONTRACTOR of materials to piping, prefabrication and module yards.
- Disposal of construction debris.
- Disposal of surplus materials.
- Respect for the environment.
- Plan and procedure for heavy lifts, including suitability of heavy lift equipment.
- Plan for modularisation, including configuration of modules, weights and sizes together with the reduction in stick built manhours on SITE which will result. TENDERER shall also indicate the Onshore and Offshore module shops which are proposed to be used.
- Scaffolding proposals.
- Construction craft productivity estimate.
- Plan for dealing with SITE labour unions, including for the administration of the SITE labour agreement.

B.13 COMMISSIONING

This shall comprise :

- Definition of lines of responsibility between CONTRACTOR and COMPANY
- Procedure, plans and systems to be used for Commissioning up to Ready for Start-up and for Handover.

in accordance with the requirements of the CONTRACT, including the following COMPANY specifications and procedures :

- MD-COM-01
- SP-COM-511
- SP-COM-512
- SP-COM-513
- SP-COM-514.

B.14 SHIPPING PLAN

This shall comprise :

- List of Materials and/or Construction Equipment required to be imported or transported.
- Description of transportation procedure that which would be applied and details of specific measures which would be undertaken to organise and co-ordinate the execution of the Transportation activities in respect of the WORK.
- Any proposals for engaging a freight forwarding SUBCONTRACTOR and supervision of its activities.
- Proposal for the use of a Marine Warranty Surveyor, if required.
- Customs clearance plan.
- Port(s) of exit.
- Port(s) of entry and local transportation.
- Details of unloading, including lighterage and wharfage if required.
- Proposed marshalling plan.

SINCOR PROJECT
CONTRACT NO C-D-01-1
PROCESS AND UTILITIES PACKAGE

- Proposed module transportation plans including use of existing and proposed docking facilities.

B.15 SUBCONTRACTING

This shall comprise :

- information regarding proposals for Subcontracting the WORK, including :
 - Plan for managing SUBCONTRACTOR WORK including safety, quality and progress.
 - name and registered address of proposed SUBCONTRACTORS, including VENDORS,
 - detailed description of any WORK to be subcontracted, both in the workshops and the field.
 - approximate value of such WORK,
 - address of yards or facilities where such WORK is to be undertaken,
 - manpower details and histograms.
 - Assurance of SUBCONTRACTOR compliance with Venezuelan labour laws.
- Plan to ensure that SUBCONTRACTORS are meeting quality requirements.
- Example of sub-contract form.

B.16 DOCUMENTATION

This shall comprise :

- procedure for preparation, distribution, control of documents for each phase
- procedure for preparation and issue of FINAL DOCUMENTATION at handover.

B.17 PROCEDURES

TENDERER shall submit a listing of all of the procedures and an index of the content of each procedure which he proposes to use for the performance of the WORK. The procedures shall cover all aspects and all phases of the WORK, including execution and co-ordination. The listing and index shall include the following :

- Quality assurance and quality control including checking (including Corporate Policy and Procedure Manuals)
- Detailed design including material take-offs
- Purchasing
- Expediting
- Inspection
- Traffic
- Spare parts procurement
- Subcontracting
- Labour productivity measurement and control
- Physical progress measurement
- Cost estimating for CHANGE ORDERS
- Health, Safety and Environment
- Documentation, and security of documentation
- Construction
- Field Safety

**SINCOR PROJECT
CONTRACT NO C-D-01-1
PROCESS AND UTILITIES PACKAGE**

- Field Security
- Precommissioning
- Commissioning
- Change control

B.18 TRAINING

TENDERER shall submit his detailed proposal for a Training Program for COMPANY personnel, upon which his proposed corresponding lump sum price stated in EXHIBIT B is based.

This shall cover Training :

- in VENDOR shops and on SITE by VENDOR Representatives for the purposes of equipment maintenance,
- in CONTRACTOR Home office and on SITE for the purposes of PLANT operation.

The Program shall cover training in the maintenance and operation of all PLANT main equipment items.

The proposal shall identify the number of sessions together with the number of Trainees.

B.19 MODULARISATION

TENDERER's base proposal shall be based upon maximising modularised construction of the PLANT, in respect of which COMPANY has included in the DESIGN DOSSIER the "Modularisation Study Report" prepared by Foster Wheeler. The intent behind the requirement for modularisation is to reduce the pressure upon labour resources at the SITE, by shifting WORK of key crafts from the field to fabrication yards.

In determining the type of modules, the benefit of modularising items (such as pipe racks) shall be carefully assessed.

TENDERER is free to determine the type, size, weight and number of the proposed modules, but will be fully responsible for the fabrication, loading/unloading transportation and installation of such modules. Inability to handle the modules at any location whatsoever shall not entitle CONTRACTOR to CONTRACT PRICE and/or schedule compensation.

TENDERER shall submit details of portions of the WORK which he is proposing to modularise.

In addition to the proposal based upon the maximisation of modularisation, TENDERER may propose alternatives based upon a lesser degree of modularisation or even stick-building (as provided for in item B.26 below). Although the base proposal shall be based upon maximum modularisation, COMPANY reserves the right to adopt the base proposal or any alternative as it deems fit.

TENDERER is free to subcontract module fabrication worldwide, on the understanding that Venezuelan yards shall be provided equal opportunity.

**SINCOR PROJECT
CONTRACT NO C-D-01-1
PROCESS AND UTILITIES PACKAGE**

B.20 CAMP FACILITIES DESCRIPTION

This section shall comprise drawings together with a full description of TENDERER's proposed camp and construction facilities, including infrastructure and associated utilities.

B.21 TELECOMMUNICATIONS

TENDERER shall submit within this section :

- details of its Telecommunications proposals for the construction phase
- details for design of the PLANT Telecommunications
- a preliminary file to assist COMPANY in ensuring proper definition of the requirements that are to be requested from local Telecommunication Authorities.

B.22 GUARANTEES

TENDERER shall provide process, mechanical and energy consumption guarantees as stated below (refer to EXHIBIT D for a full description of the requirements) :

Process Guarantees :

TENDERER shall specify the capacity, yield and stream quality guarantees for the non-licensed units (Desalting Crude Distillation Unit, Vacuum Distillation Unit and Utilities Facilities).

Mechanical Guarantees

TENDERER shall mechanically guarantee the 18 months from Provisional Acceptance, or 24 months from Mechanical Acceptance, whichever is earlier.

Energy Consumption Guarantee

TENDERER shall submit his proposed Energy Consumption Guarantee (including utilities and fuel consumption) for the PLANT, based upon the technical proposal within his TENDER.

TENDERER's guarantee proposals shall include specific guarantee levels and the method and procedure for measurement and reporting on performance.

B.23 TENDERER'S OTHER COMMITMENTS

TENDERER shall submit within this section a tabulation showing TENDERER's current and projected work-load as of the TENDER due date and forecast of work-load throughout the CONTRACT period. All projects shall be individually identified by location and name of client.

TENDERER shall also provide a tabulation in the attached format showing current staff levels, levels projected for the 20th August, 1998 and peak requirements. The

**SINCOR PROJECT
CONTRACT NO C-D-01-1
PROCESS AND UTILITIES PACKAGE**

tabulation shall be provided for all locations in which the CONTRACTOR will be performing the WORK.

PERSONNEL CATEGORY	CURRENT	PROJECTED 20TH AUGUST, 1998	PEAK REQUIREMENT UNDER THE CONTRACT
Project Organisation			
Project management/engineering			
Planning/scheduling			
Schedule control			
Cost estimating			
Cost control			
Material control			
Home office construction management			
Quality assurance/quality control			
Safety			
Production Engineering			
Facility planning			
Design and drafting			
CADD operators			
Specialist engineering			
Process			
Mechanical			
Piping			
Electrical			
Instrumentation			
Control systems			
Heat exchange			
Furnace			
Civil			
Rotating equipment			
Vessels			
Environmental			
Architectural			
Procurement			
Purchasing			
Inspection			
Expediting			
Construction management			
Senior site management			
Field planning/scheduling			
Field cost estimating			
Field cost control			
Field warehousing/material control			
Site safety and security			
Quality control			

**SINCOR PROJECT
CONTRACT NO C-D-01-1
PROCESS AND UTILITIES PACKAGE**

Field engineering			
Field engineering			
Field purchasing/contract admin			
Purchasing			
Shop inspection			
Expediting			
Subcontracting			
Field supervision			
Construction supervision			
Site inspection			
<i>Any additional categories to be inserted by TENDERER :</i>			

B.24 TENDERER'S PREVIOUS EXPERIENCE

TENDERER shall submit within this section a tabulation showing TENDERER's previous experience upon projects of the same or similar nature to the subject WORK. The tabulation shall include :

- a description of the work,
- location,
- client,
- value,
- date completed.

B.25 QUALIFICATIONS

The TENDER is required to be made in strict accordance with the technical and commercial requirements of the TENDER DOCUMENTS.

Qualifications may only be made in relation to items within the TENDER DOCUMENTS which the TENDERER feels unable to comply with under any circumstances or at any price. If the TENDERER wishes to make any qualifications this must be done by listing the full details of each qualification, stating the reason for the qualification.

Qualifications must be distinguished from Alternatives. If TENDERER is prepared to carry out and can price a requirement, but would prefer an offered Alternative, TENDERER must price the requirement and not qualify the TENDER; but in this case TENDERER may, at its option, suggest an Alternative as described for section B.26.

TENDERER'S QUALIFICATIONS TO THE TENDER DOCUMENTS

This Table lists all of TENDERER's Qualifications to the TENDER DOCUMENTS

TENDER DOCUMENTS Reference	Description of Qualification, including suggested modification to the TENDER DOCUMENTS	Reason for Qualification

**SINCOR PROJECT
CONTRACT NO C-D-01-1
PROCESS AND UTILITIES PACKAGE**

B.26 ALTERNATIVES

This section shall comprise any alternative(s) TENDER proposed by TENDERER to the technical requirements set-out within the TENDER DOCUMENTS. TENDERER must set out the precise details of both the original requirement and the suggested Alternative(s) together with the reason for the Alternative(s) the effect, if any, on the delivery schedule and within section A.9 any impact upon the prices, rates and other requirements of the TENDERER DOCUMENTS if the Alternative(s) were to be accepted by COMPANY. Any matters detailed as Alternative(s) must be clearly distinguished from qualifications; Alternatives do not affect the base offer made by the TENDERER in the TENDER : they are complete alternatives to that offer.

Alternatives should not challenge the broad concepts of the TENDER DOCUMENTS but should reduce the TENDER price or improve the schedule or operating economics while still meeting the technical requirements of the CONTRACT. Alternatives shall be presented in a manner which enable COMPANY at its option, to accept or reject any such proposed Alternatives.

INSTRUCTIONS TO TENDERERS

APPENDICES

**SINCOR PROJECT
CONTRACT NO C-D-01-1
PROCESS AND UTILITIES PACKAGE**

APPENDIX 1

FORM OF ACKNOWLEDGEMENT

Attention: Mr. A. de Chezelles

Subject: CONTRACT NO C-D-01-1
TENDER DOCUMENTS - PROCESS AND UTILITIES PACKAGE

Dear Sir:

We acknowledge receipt of your Invitation to Tender and the TENDER DOCUMENTS for the above-mentioned work, and are in receipt of all documents listed therein.

- (*) We hereby accept to respond to your invitation and to submit our TENDER no later than the closing date and we agree to comply with your instructions to TENDERERS.
- (*) We hereby decline your invitation, and will return forthwith your TENDER DOCUMENTS, all in accordance with your instructions to TENDERERS.
- (*) We hereby nominate Mr/Ms , tel no , fax no as our contact for this TENDER.

Yours faithfully,

For and on behalf of:

Date:

(*) Delete as applicable

To be submitted to Mr. A.deChezelles by telefax (1) 908-730-5400, and confirmed by letter to the following address :

c/o Foster Wheeler USA Corporation
Sincor Downstream Project
P.O. Box 4993
Clinton, New Jersey 08809-4000
USA

**SINCOR PROJECT
CONTRACT NO C-D-01-1
PROCESS AND UTILITIES PACKAGE**

APPENDIX 2

FORM OF PARENT COMPANY GUARANTEE

Ref.: SINCOR PROJECT

Dear Sirs:

CONTRACT NO C-D-01-1, FOR THE PROCESS AND UTILITIES PACKAGE

1. With reference to the accompanying TENDER for the above CONTRACT, we, as (b) 's ultimate holding company do hereby enter into the following unconditional and irrevocable undertakings with (a), (hereinafter referred to as "COMPANY"), and the Participants in the "Operacion Mancomunada", that on condition that COMPANY enters into CONTRACT with (b) for the above subject and in consideration of the same:
 - 1.1 (b) shall perform all his obligations contained in the said CONTRACT, and,
 - 1.2 If (b) shall in any respect fail to perform the said obligations contained in the said CONTRACT or commits any breach thereof, we shall ourselves perform on the simple demand by COMPANY or take whatever steps may be necessary to achieve performance of the obligations under the CONTRACT of (b) and shall indemnify and keep indemnified COMPANY and the Participants in the "Operacion Mancomunada" against any loss, damages, costs and expenses, for which (b) may be liable thereunder, howsoever arising from the said failure or breach.
2. We shall not be discharged or released from our undertakings hereunder by any waiver or forbearance by COMPANY whether as to payment, time, performance or otherwise.
3. This guarantee shall be unconditional, irrevocable, without benefit of discussion and shall continue until all (b)'s obligations under the CONTRACT have been performed, notwithstanding:
 - any alterations or additions to or deletions from the CONTRACT and/or
 - any modifications in the shareholding relationship between us and (b) and/or
 - any assignment in accordance with the CONTRACT.
4. The expression CONTRACT shall have the meaning ascribed to it in the AGREEMENT.

**SINCOR PROJECT
CONTRACT NO C-D-01-1
PROCESS AND UTILITIES PACKAGE**

5. This document shall be construed and take effect in accordance with the laws of England and any proceedings for enforcement shall be brought before the High Court of Justice in London, England.

Yours faithfully,

Signed: for and on behalf of (TENDERER's ultimate holding Company)

(d)

Name:

Title:

Date:

- (a) Name of COMPANY
- (b) Name of TENDERER
- (c) Delete AGREEMENT or GENERAL CONDITIONS OF PURCHASE as relevant
- (d) Common seal of signature of TENDERER's ultimate holding Company of such formalities as may be required under the law or articles of association to render a unilateral promise binding on TENDERER's ultimate holding Company. Each page (other than signature page) to be duly initialled.

**SINCOR PROJECT
CONTRACT NO C-D-01-1
PROCESS AND UTILITIES PACKAGE**

APPENDIX 3

FORM OF BID BOND

(BANK GUARANTEE)

- I. We, the Undersigned (1) (hereinafter referred to as GUARANTOR), established at (2) represented by (3), have taken notice of the TENDER, submitted by (4) whose registered office is at (5), (hereinafter referred to as TENDERER) to (6) (hereinafter called COMPANY) a Company registered under the laws of, with its registered office at (7), for (8)
- II. GUARANTOR hereby guarantees the due performance by TENDERER of TENDERER's obligations under the TENDER DOCUMENTS.
- III. If TENDERER fails to comply with any of his obligations under the TENDER DOCUMENTS and/or if TENDERER withdraws said TENDER within the period of validity of his TENDER and/or if TENDERER fails after receipt from COMPANY of notice of award to enter into the CONTRACT with COMPANY, or to provide a Performance Bond in accordance with CONTRACT requirements, then GUARANTOR hereby irrevocably undertakes on behalf of CONTRACTOR to pay to COMPANY on first demand any sum or sums not exceeding USD_____
- IV. Each demand by COMPANY for payment under this Guarantee shall be made in writing (including telex or cable) to the following address:

(11)
Telex:
GUARANTOR shall promptly notify to COMPANY any change in the above address.
- V. Each demand under paragraph IV above shall indicate the breach of TENDERER's obligations as notified to TENDERER by COMPANY.
- VI. GUARANTOR shall make payment hereunder on first demand without restriction or conditions and notwithstanding any objection by TENDERER. GUARANTOR shall not require COMPANY to justify the breach indicated in its demand for payment, nor shall GUARANTOR have any recourse against COMPANY in respect of any payment made hereunder.
- VII. No alteration in the terms of the TENDER made by agreement between TENDERER and COMPANY shall in any way release GUARANTOR from all or any part of its liabilities under this Guarantee.
- VIII. GUARANTOR shall pay any sum demanded by COMPANY hereunder within fifteen (15) calendar days after the date of receipt of COMPANY's demand.

SINCOR PROJECT
CONTRACT NO C-D-01-1
PROCESS AND UTILITIES PACKAGE

- IX. This Guarantee shall be valid for one hundred and fifty (150) calendar days from the closing date for the TENDER and in the event that TENDERER is notified of the award of the CONTRACT by COMPANY it shall in addition be valid until signature of the CONTRACT by TENDERER and COMPANY and the approval by COMPANY of the Performance Bond for the CONTRACT.
- X. The expression CONTRACT shall have the meaning ascribed to it in the form of AGREEMENT.
- XI. This Guarantee shall be interpreted in accordance with the laws of England and any proceedings for enforcement shall be brought before the High Court of Justice in London, England.
- XII. GUARANTOR represents that this Guarantee has been established in such form and with such content that it is fully and freely enforceable against GUARANTOR in the manner provided in paragraph XI above.

(Date)

(Common Seal of Signature of GUARANTOR or such other formality as may be required under the law to render a unilateral promise binding on the GUARANTOR).

- (1) Name of the Bank proposed by TENDERER to be approved by COMPANY
- (2) Address of Bank
- (3) GUARANTOR officer's name and quality
- (4) Name of TENDERER
- (5) Address of office of TENDERER
- (6) Name of COMPANY
- (7) Address of COMPANY
- (8) References title and purpose of the call for TENDER
- (9) In figures and letters
- (10) Bank address for notices

**SINCOR PROJECT
CONTRACT NO C-D-01-1
PROCESS AND UTILITIES PACKAGE**

APPENDIX 4

FORM OF TENDER

(To be included in the Commercial Proposal, Section A.2 hereinabove)

To: **FOSTER WHEELER USA CORPORATION
SINCOR PROJECT
PERRYVILLE CORPORATE PARK
CLINTON
NJ 08809
USA**

Attention : A.de Chezelles

**SINCOR PROJECT, CONTRACT C-D-01-1
PROCESS AND UTILITIES PACKAGE**

Dear Sirs,

1. Having examined and noted the TENDER DOCUMENTS, i.e.:
 - Invitation to Tender
 - Instructions to Tenderers
 - Form of Agreement, together with
 - Annex 1 : Form of Bank Guarantee
 - Annex 2 : Form of Final Account Certificate
 - Annex 3 : Indemnity and Waiver of Recourse Agreements
 - Annex 4 : Liability and Insurance Agreement from Subcontractors
 - Annex 5 : Construction All Risks Policy Summary
 - Annex 6 : Form of Contractor's Parent Company Guarantee
 - Annex 7 : Form of Assignment Agreement
 - Annex 8 : Form of Certificate of Endorsement of Design Dossier
 - Annex 9 : Form of Interim Certificates
 - Annex 10 : Form of Provisional Acceptance Certificate
 - Annex 11 : Form of Final Acceptance Certificate
 - Annex 12 : Labour Agreement
 - Exhibit A : Scope of Work
 - Exhibit B : Schedule of Prices
 - Exhibit C : Work Time Schedule
 - Exhibit D : Performance Guarantees
 - Exhibit E : Design Dossier
 - Exhibit F : Particular Conditions for Performance of the Work
 - Exhibit G : Co-ordination Procedure
 - Exhibit H : Quality Assurance and Quality Control
 - Exhibit I : Company Items
 - Exhibit J : List of Subcontractors and Vendors
 - Exhibit K : Contractor's Organisation and Key Personnel
 - Exhibit L : Health, Safety and Environment

And considering the Technical Proposal submitted separately as specified in the Instructions to Tenderers, we undertake to carry out the WORK and perform all services and obligations described in the TENDER DOCUMENTS in accordance with the contractual dates stated in EXHIBIT C forming part of the

**SINCOR PROJECT
CONTRACT NO C-D-01-1
PROCESS AND UTILITIES PACKAGE**

ATTACHMENT I

ALL-IN WAGE RATE AND ALL-IN SUBCONTRACTOR RATE BUILD UP

EXHIBIT C

WORK TIME SCHEDULE

**SINCOR PROJECT
CONTRACT NO C-D-81-1
PROCESS AND UTILITIES PACKAGE**

WORK TIME SCHEDULE

1. GENERAL

The CONTRACT shall commence, or be deemed to have commenced, upon the EFFECTIVE DATE, and shall continue, subject to the provisions of Articles 49, 50 and 51 of the AGREEMENT, until completion of all of the WORK hereunder.

**SINCOR PROJECT
CONTRACT NO C-D-01-1
PROCESS AND UTILITIES PACKAGE**

2. WORK TIME SCHEDULE

ITEM	MILESTONE
2.1 EFFECTIVE DATE.	-----*
2.2 Date for submission of Detailed Work Time Schedule.	Within 30 days after EFFECTIVE DATE
2.3 Date for commencement of mobilisation to SITE.	**
2.4 Completion of all of the WORK necessary in order for COMPANY to issue the final READY FOR START UP CERTIFICATE in respect of the DCS, including for the Technical Rooms and Cental Control Room.	1st August, 2000
2.5 Completion of all of the WORK necessary in order for COMPANY to issue the final MECHANICAL COMPLETION CERTIFICATE in respect of the Utilities, including all associated interconnecting pipework.	1st March, 2001
2.6 Completion of all of the WORK necessary in order for COMPANY to issue the final READY FOR START UP CERTIFICATE in respect of the of the Utilities, including all associated interconnecting pipework.	1st April 2001
2.7 Completion of all of the WORK necessary in order for COMPANY to issue the final MECHANICAL COMPLETION CERTIFICATE in respect of the Process, including all associated interconnecting pipework.	1st June, 2001
2.8 Completion of all of the WORK necessary in order for COMPANY to issue the final READY FOR START UP CERTIFICATE in respect of the of the Process, including all associated interconnecting pipework, being COMPLETION DATE.	1st August, 2001
2.9 Submission of all remaining FINAL DOCUMENTATION.	Within 30 days following COMPLETION DATE

**For the purposes of preparation of his TENDER, TENDERER shall assume an EFFECTIVE DATE of the 20th August, 1998*

***Proposed dates to be inserted by TENDERER*

**SINCOR PROJECT
CONTRACT NO. C-D-01-1
PROCESS AND UTILITIES PACKAGE**

3. CONTRACTOR'S PRELIMINARY DETAILED WORK TIME SCHEDULE

(TENDERER's preliminary schedule to be inserted in any eventual CONTRACT)



**FACULTAD DE INGENIERIA U.N.A.M.
DIVISION DE EDUCACION CONTINUA**

CURSOS INSTITUCIONALES

**DIPLOMADO GERENCIA DE PROYECTOS
ICA-DECFI, UNAM**

**Módulo III "Suministros"
24, 25 y 26 de junio de 1999**

"Las Presas de Almacenamiento. Generalidades"

Ing. Macario Vega Pérez
Palacio de Minería
1999

**UNIVERSIDAD NACIONAL AUTONOMA DE MEXICO
FACULTAD DE INGENIERIA
DIVISION DE EDUCACION CONTINUA**

**LAS PRESAS DE ALMACENAMIENTO
GENERALIDADES**

**Ing. Macario Vega Pérez
México, D.F., junio de 1999.**

LOS ESTUDIOS EN LOS PROYECTOS CIVILES DE OBRAS HIDRAULICAS ENCAMINADOS A PRESAS DE ALMACENAMIENTO.

Las obras de ingeniería, requieren de un mínimo de información básica para su dimensionamiento y elaboración de su diseño tanto de la obra en sí, como de su cimentación.

En lo que se refiere a obras hidráulicas y especialmente a presas de almacenamiento, independientemente de su magnitud, se requieren estudios perfectamente definidos y detallados para su localización, concepción, arreglo general, (emplazamiento de estructuras), dimensionamiento, diseño y construcción.

En general se requiere:

1. Topografía de vaso y boquilla a escalas apropiadas.
2. Estudio Hidrológico de la corriente.
3. Geotecnia

La ingeniería geotécnica se clasifica de la siguiente manera:

- a) Geología Aplicada a la Ingeniería
 - b) Mecánica de Rocas (macizos rocosos)
 - c) Mecánica de Suelos (depósitos sueltos y suelo residual)
 - d) Geofísica (sísmica, eléctrica)
4. Estudio Especifico de Bancos de Materiales
 5. Impacto ambiental (explicar).

LOS ESTUDIOS

TOPOGRAFIA.-

La topografía nos representa en un plano, la forma que tiene el terreno natural en la zona donde se pretende el proyecto.

Partiendo de una topografía detallada, a escala adecuada según el caso, se afina la localización de las obras, especialmente la cortina; y también se obtiene la Gráfica Elevaciones-Capacidades del Vaso.

Ya la forma topográfica de la boquilla, nos da los primeros indicios del tipo de cortina adecuada a la misma.-Se hacen esquemas de localización de las partes que integran la presa para tener idea del proyecto.

HIDROLOGIA.-

Como requisito indispensable se debe contar con un estudio hidrológico para conocer el régimen de la corriente por aprovechar y el volumen de agua con que se cuenta, qué demanda se puede satisfacer según el objetivo del aprovechamiento y con ello, determinar la capacidad útil necesaria en la presa, que sumada al azolve probable, dará el volumen al NAMO, a esto se le denomina "funcionamiento de Vaso".

Como complemento de lo anterior, se debe realizar un Estudio de Avenidas para determinar el máximo gasto de entrada al vaso de la avenida máxima probable asociada a un período de retorno y el gasto máximo de descarga al transitar por el vaso y mediante obra de excedencias determinada; esto nos da como consecuencia, la necesidad de contar con un volumen disponible para la regulación, que sumado al volumen útil y al de azolves, nos dará el volumen total o capacidad total de la presa (NAME).

Lo anterior se conoce como "Tránsito de Avenidas".

Además, habrá que calcular el B.L, que sumado al NAME, dará la elevación de la corona de la cortina.

GEOTECNIA

a) Geología aplicada a la Ingeniería.-

La geología aplicada a la ingeniería civil, en el caso de presas, permite estudiar el comportamiento estructural y las características de permeabilidad de las formaciones geológicas en el vaso, la boquilla y las laderas.

Las fallas, los plegamientos, los estratos, los aparatos volcánicos, los derrames lávicos, el grado de alteración de las formaciones y su origen, interesan durante la etapa de estudios previos al diseño de las presas.

Una vez ubicado el eje de la cortina que es lo mas importante, desde el punto de vista topográfico y de geología superficial, se procede a elaborar un Programa de Sondeos con la localización y profundidad que se pretenda de cada uno.

Los Sondeos se especificarán si son verticales o con alguna inclinación, con recuperación de muestras y pruebas de permeabilidad.

Se vaciará la información de cada sondeo en un plano donde se anotará el % de recuperación y la calidad de la roca mediante la observación de los núcleos obtenidos.

b) Mecánica de Rocas.-

La estabilidad de laderas en vaso y boquilla, generalmente formadas por macizos rocosos, es materia de Mecánica de Rocas, otra rama de la ingeniería geotécnica de utilidad en estudios de más detalle.

Esta disciplina también aporta herramientas para diseñar los tratamientos de inyección para impermeabilizar boquillas, localizar y explotar eficientemente bancos de roca para construcción de presas o para producir agregados de concreto, así como la técnica adecuada para excavar túneles y galerías dentro de un macizo rocoso.

c).-Mecánica de Suelos.-

Como parte también de los estudios detallados, la Mecánica de Suelos permite investigar las propiedades, índices y mecánicas de materiales térreos (limosos, arcillosos o mezclados con granulares), aptos para el núcleo impermeable, transiciones y respaldos en el diseño de secciones de cortinas de las presas de "materiales graduados", así como agregados para concretos.

d) Geofísica.-

Finalmente la Geofísica significa gran ayuda para conocer la potencialidad de bancos de préstamo de arcilla y grava-arena, lo mismo para determinar espesores de acarreo en los cauces de los ríos o para determinar espesores de limpias y elevaciones de desplante de cortinas.

Con la diferencia entre la elevación de desplante y la elevación de la corona, se tendrá la altura total de la cortina en su sección máxima.

4.- Estudio Especifico de Bancos de Materiales.

- e) De material impermeable (arcilla)
- f) De grava arena
- g) De roca

Esta misma disciplina de la ingeniería geotécnica se ocupa de localizar e investigar bancos de materiales, con la guía del geólogo, tanto para el núcleo como para los filtros y transiciones, interactuando simultáneamente con el proyectista para seleccionar los sitios y procedimientos de explotación más económicos.

5.- Impacto Ambiental (explicar).

PROYECTO EJECUTIVO.-

Una vez contando con la topografía, el estudio hidrológico, el de Geotecnia y el de Bancos de Materiales, ya es posible dimensionar la presa y proponer un tipo de cortina, de obra de desvío, de obra de toma y de obra de excedencias; se empezará por realizar esquemas, luego un anteproyecto y así llegar a definir un Proyecto Ejecutivo con planos constructivos, especificaciones, catálogo de conceptos de trabajo con cantidades de obra y un "cronograma de construcción". Este cronograma o programa de construcción en el caso de las presas es muy particular ya que deberá estar supeditado al régimen del río y no al arbitrio de los constructores.

(ampliar explicación verbal).

CORTINA.-

Una presa de almacenamiento se integra de las siguientes partes:

- a) Cortina
- b) Obra de desvío
- c) Obra de excedencias
- d) Obra de toma.

La cortina es la parte principal y se define como una estructura construida en un estrechamiento del cauce de una corriente llamada "boquilla" que al interceptar los escurrimientos provoca una almacenamiento, a esto se le denomina presa.

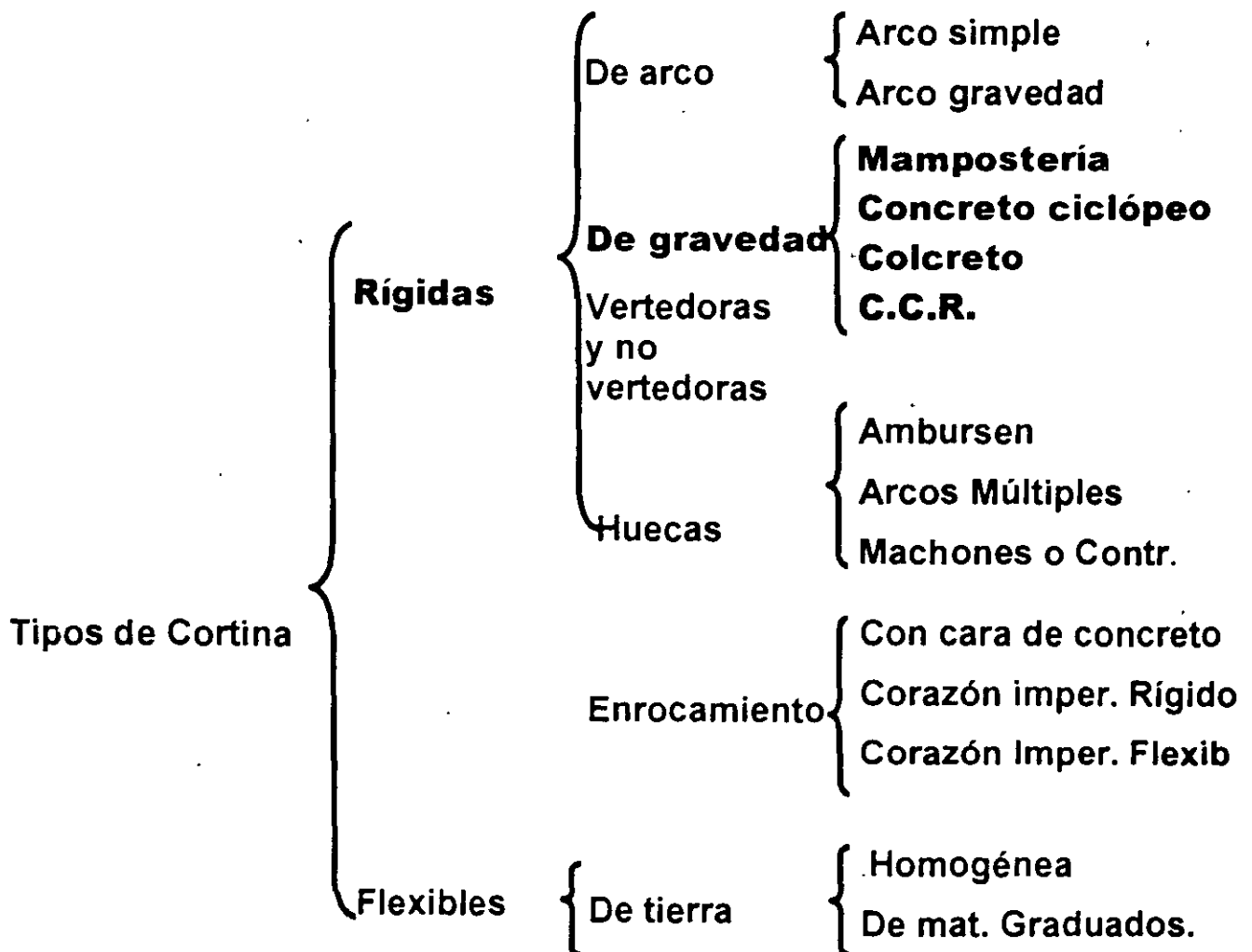

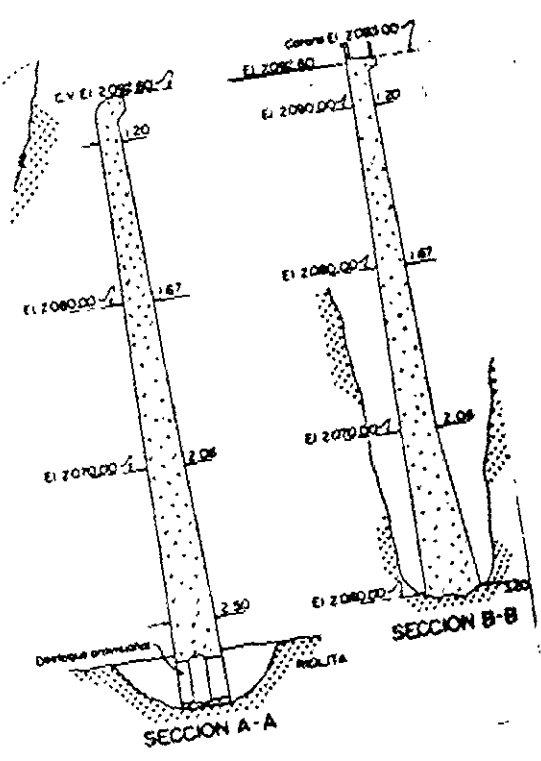
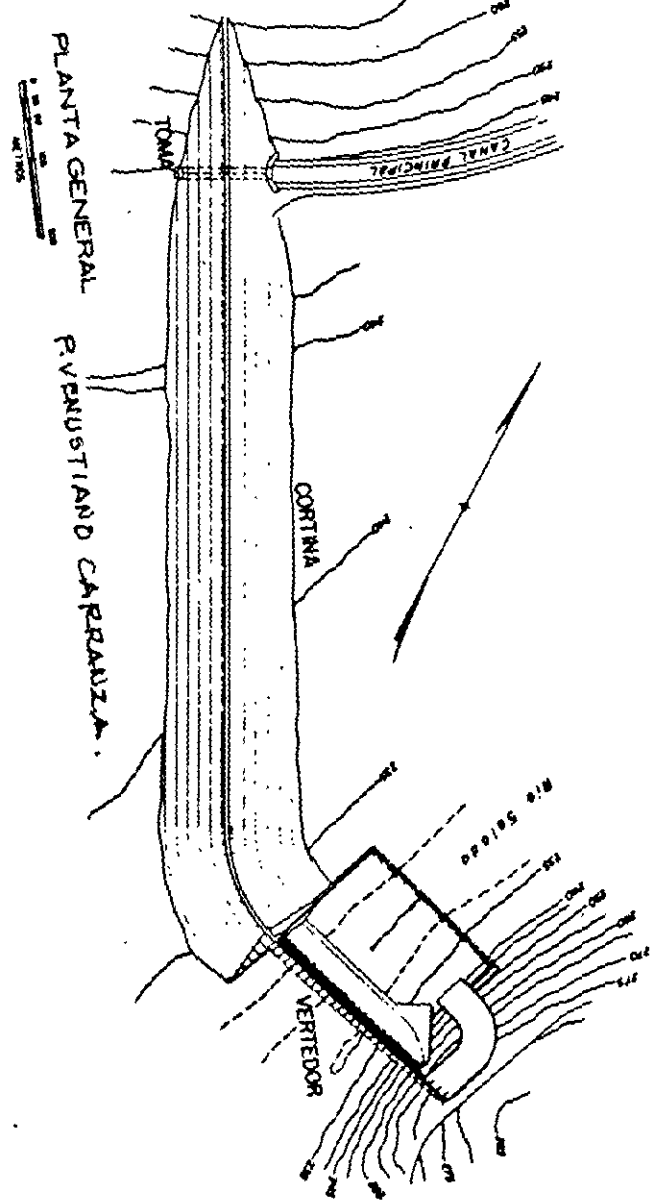
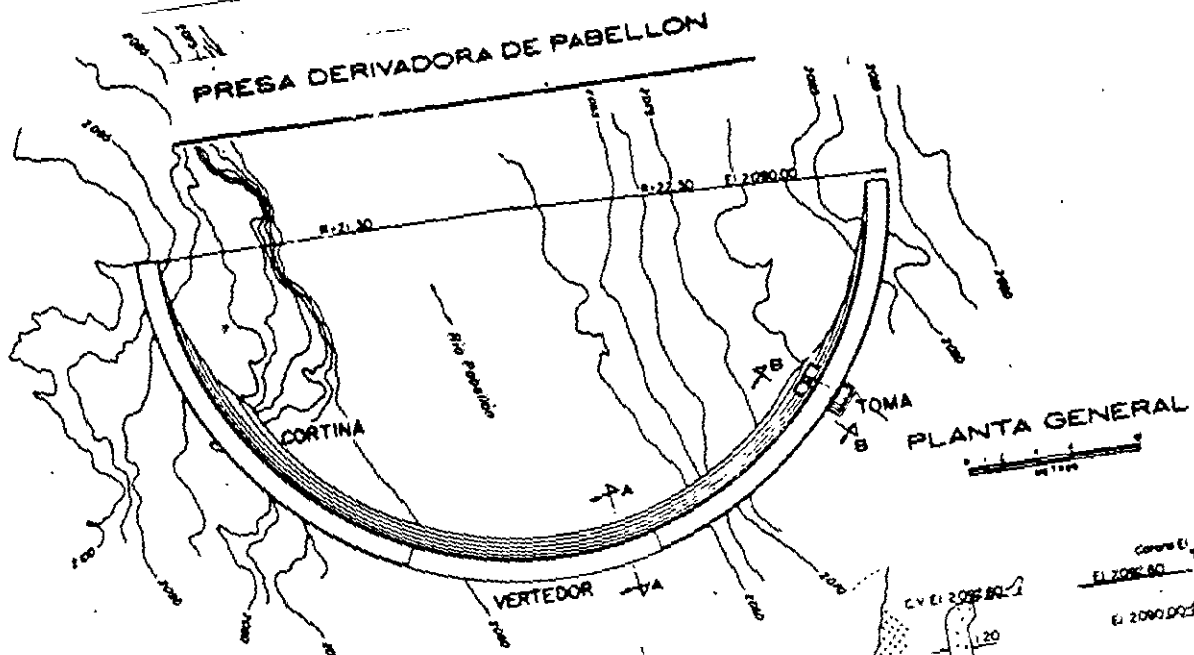

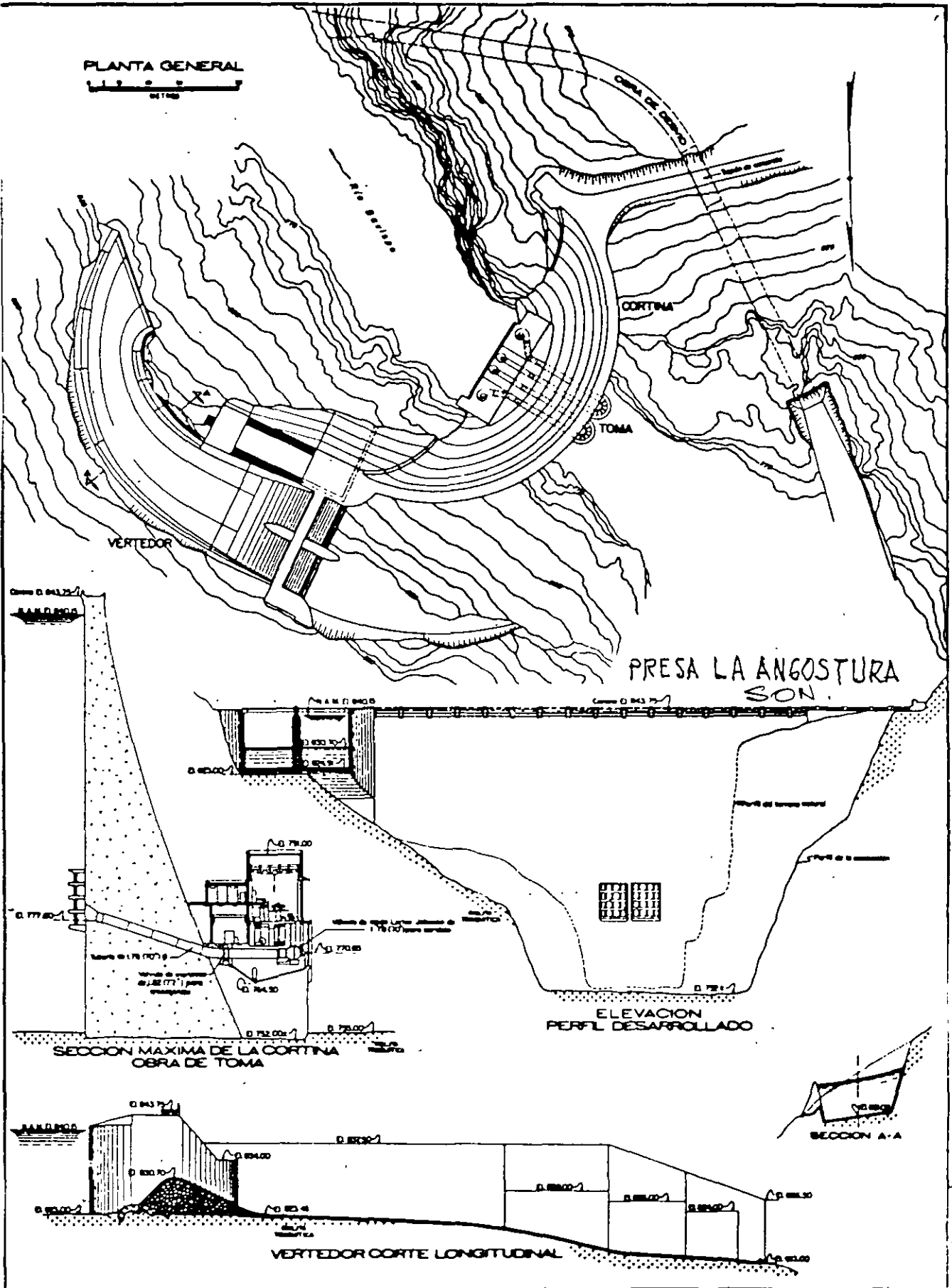

PRESA CALLES

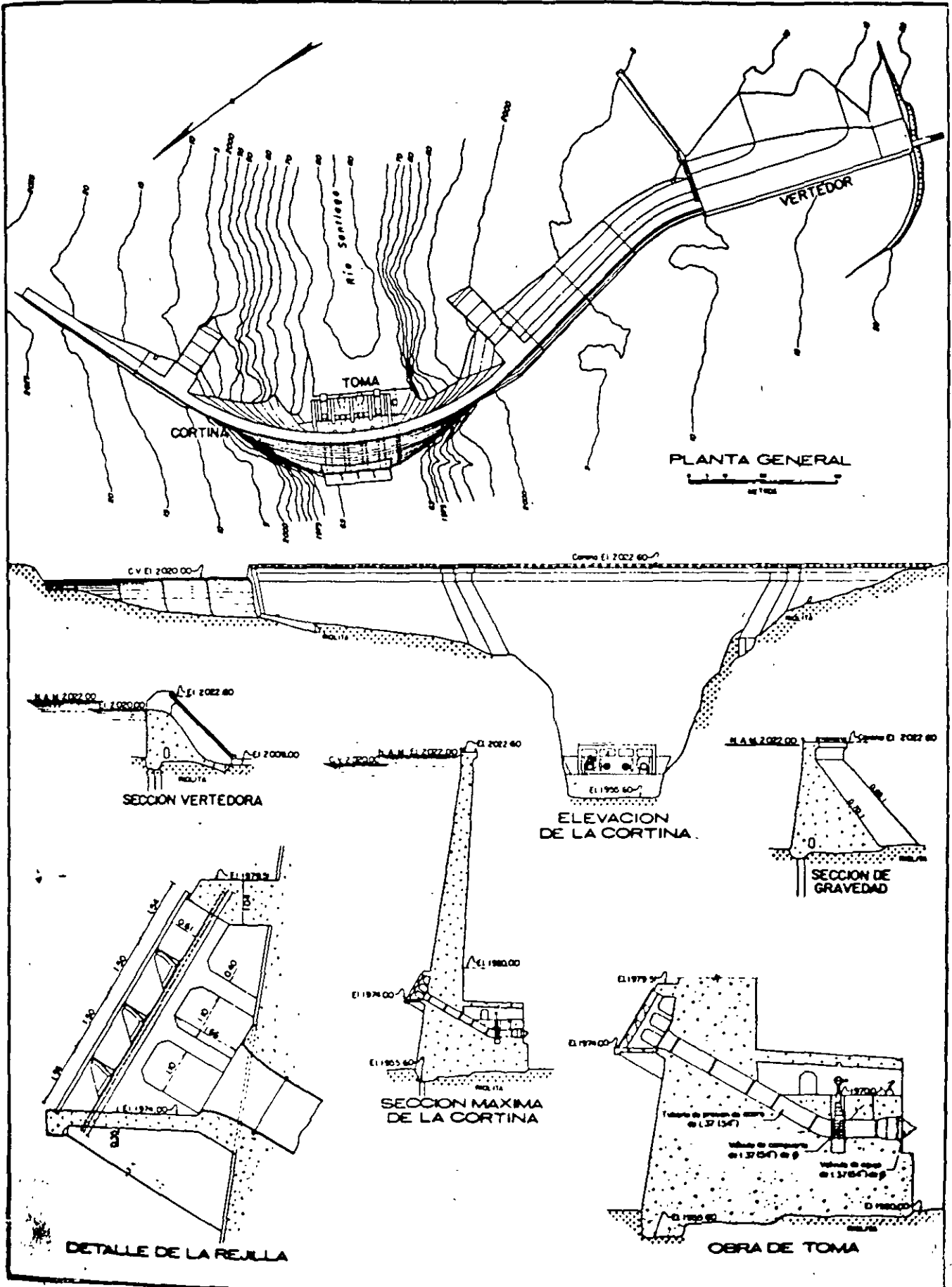

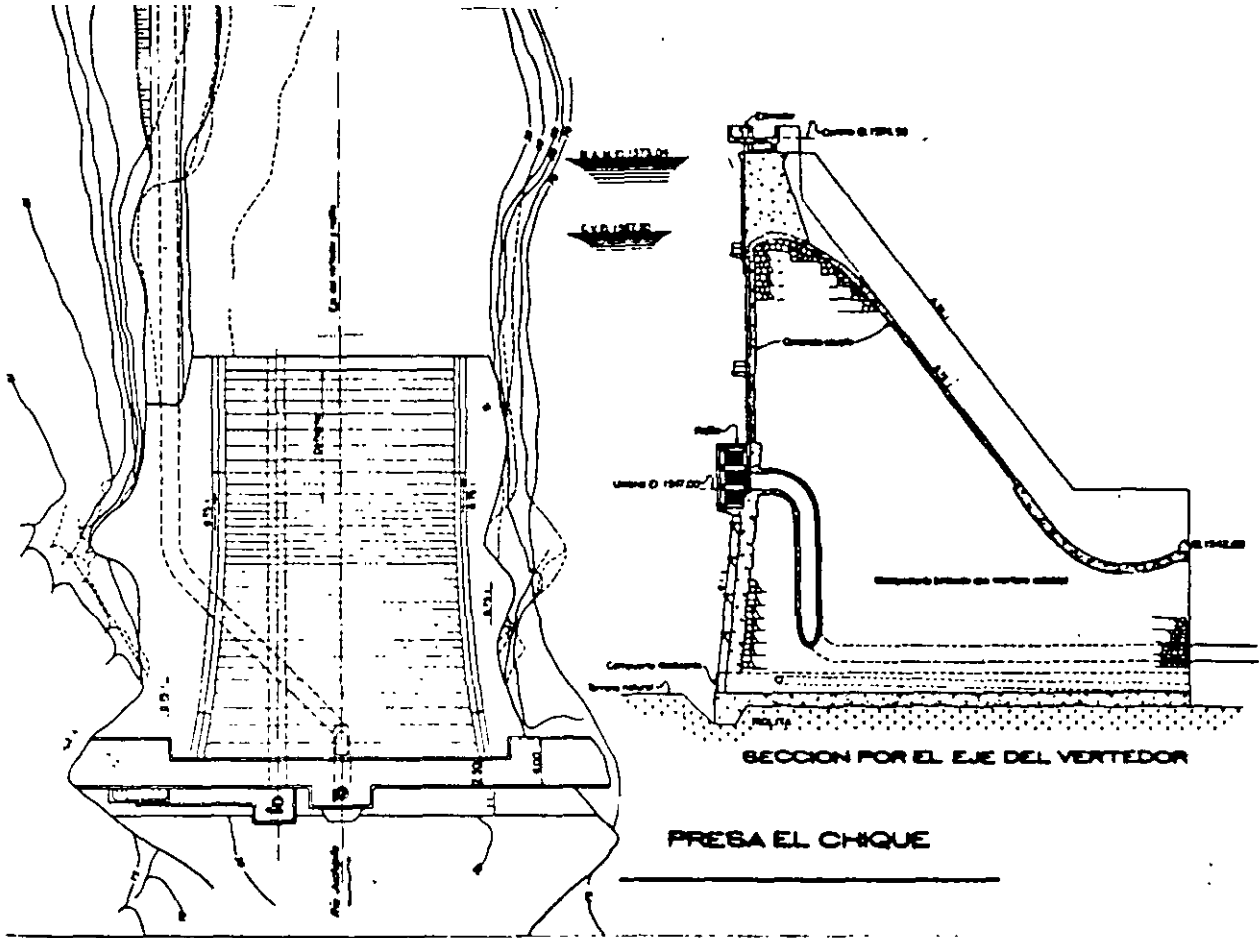

PRESA EL CHIQUE

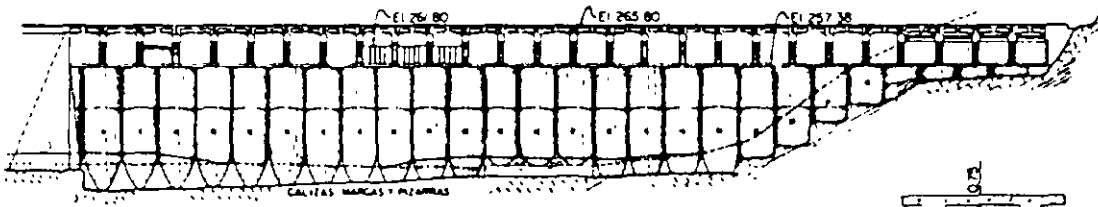

VERTEDOR - ELEVACION

PRESA VENUSTIANO CARRANZA

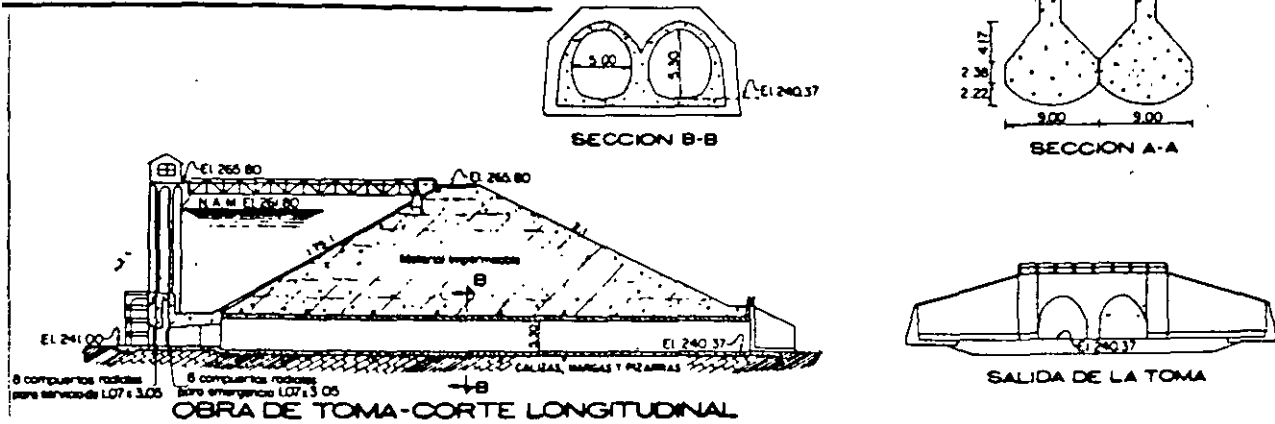

OBRA DE TOMA - CORTE LONGITUDINAL

SALIDA DE LA TOMA

PRESA FRANCISCO I MADERO

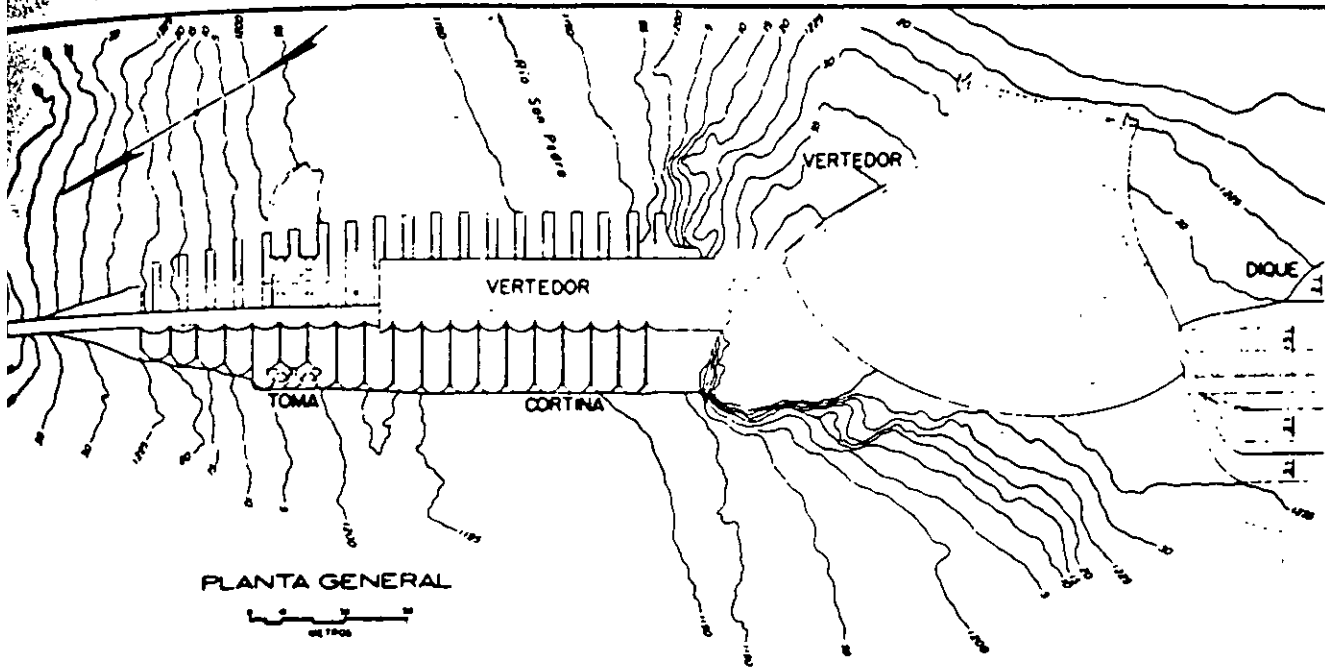

PLANTA GENERAL

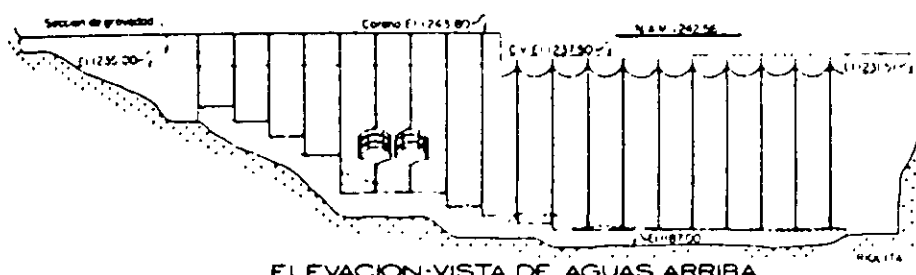

ELEVACION-VISTA DE AGUAS ARRIBA

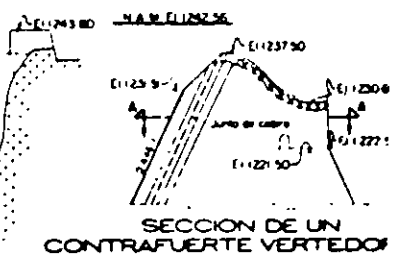

SECCION DE UN CONTRAFUERTE VERTEDOR

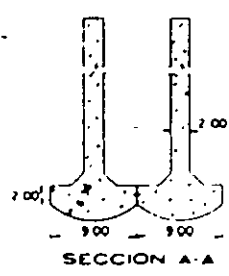

SECCION A-A

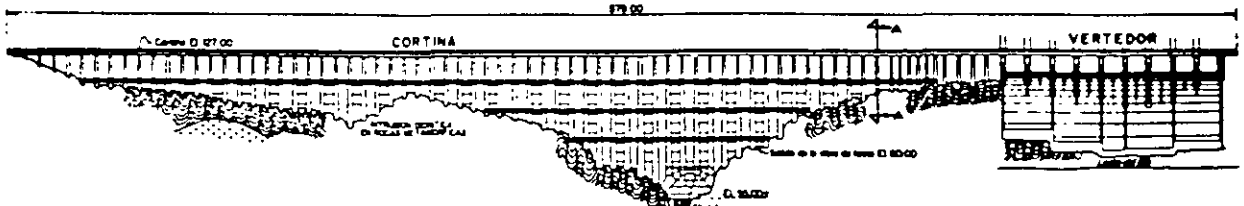

ELEVACION VISTA DE AGUAS ABAJO

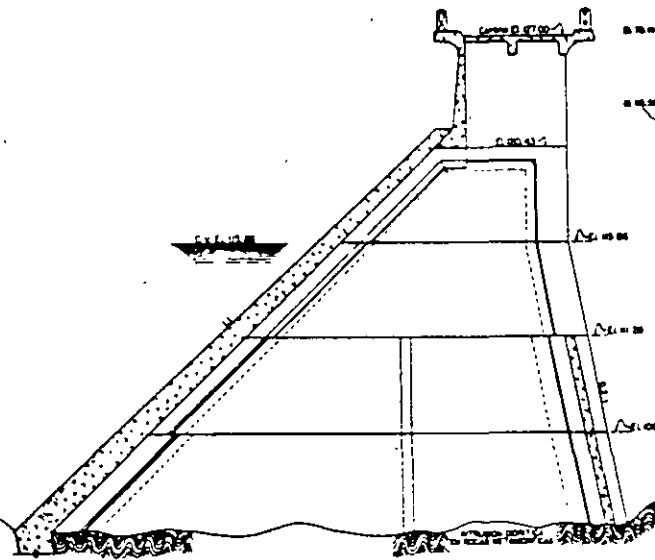

SECCION A-A DE LA CORTINA

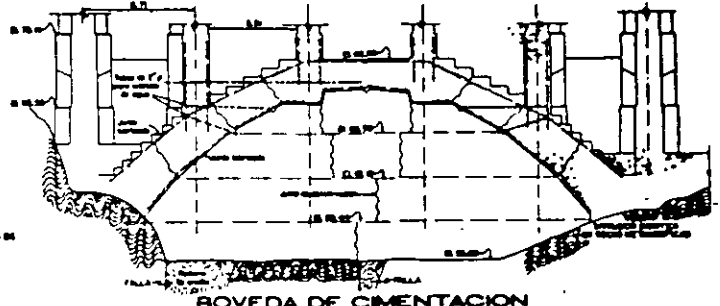

BOVEDA DE CIMENTACION

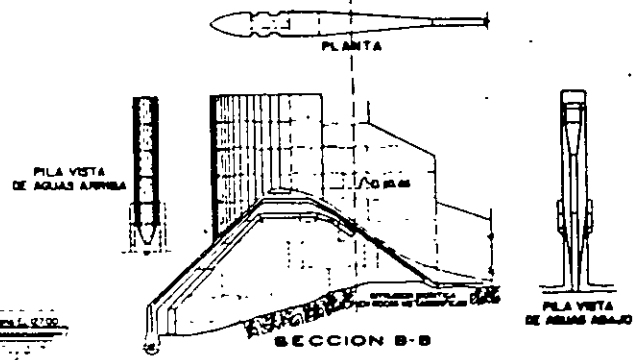

SECCION B-B

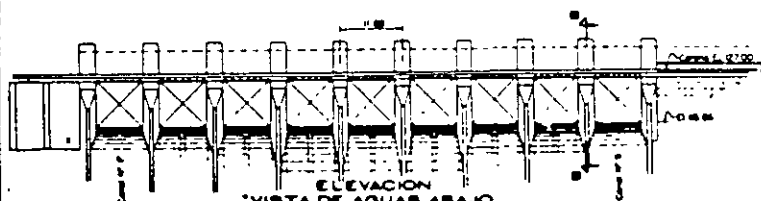

ELEVACION VISTA DE AGUAS ABAJO

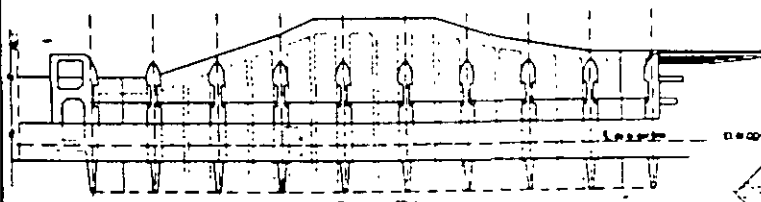

PLANTA VERTEDOR

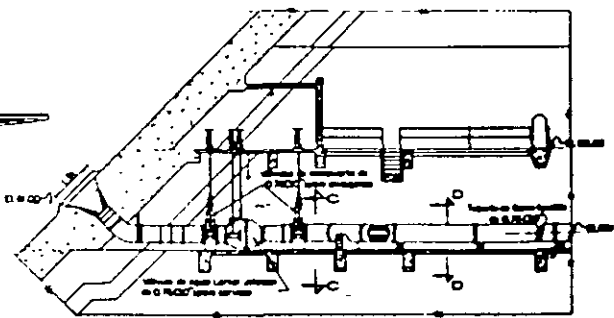

ELEVACION

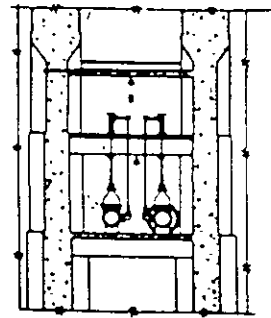

SECCION C-C

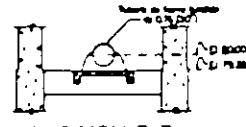

SECCION D-D

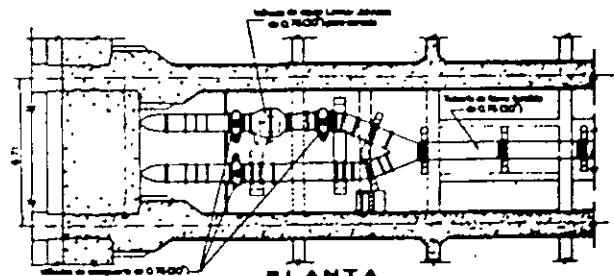

PLANTA OBRA DE TOMA

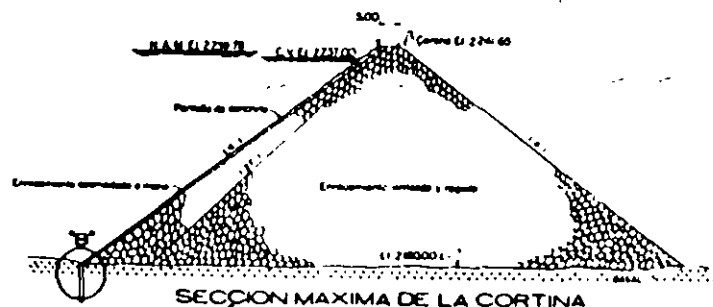

SECCION MAXIMA DE LA CORTINA
PRESA SAN ILDEFONSO

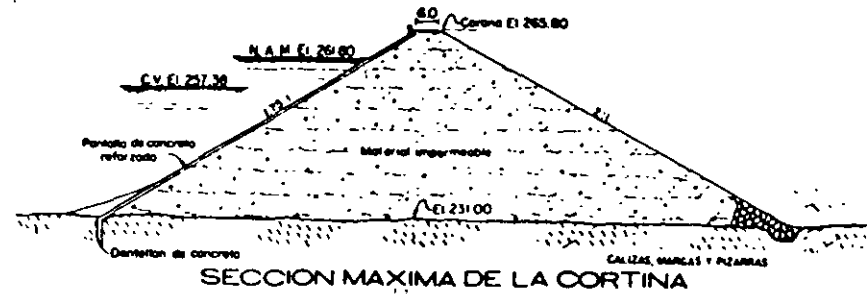

SECCION MAXIMA DE LA CORTINA

PRESA NETZAHUALCOYOTL, CHIS.

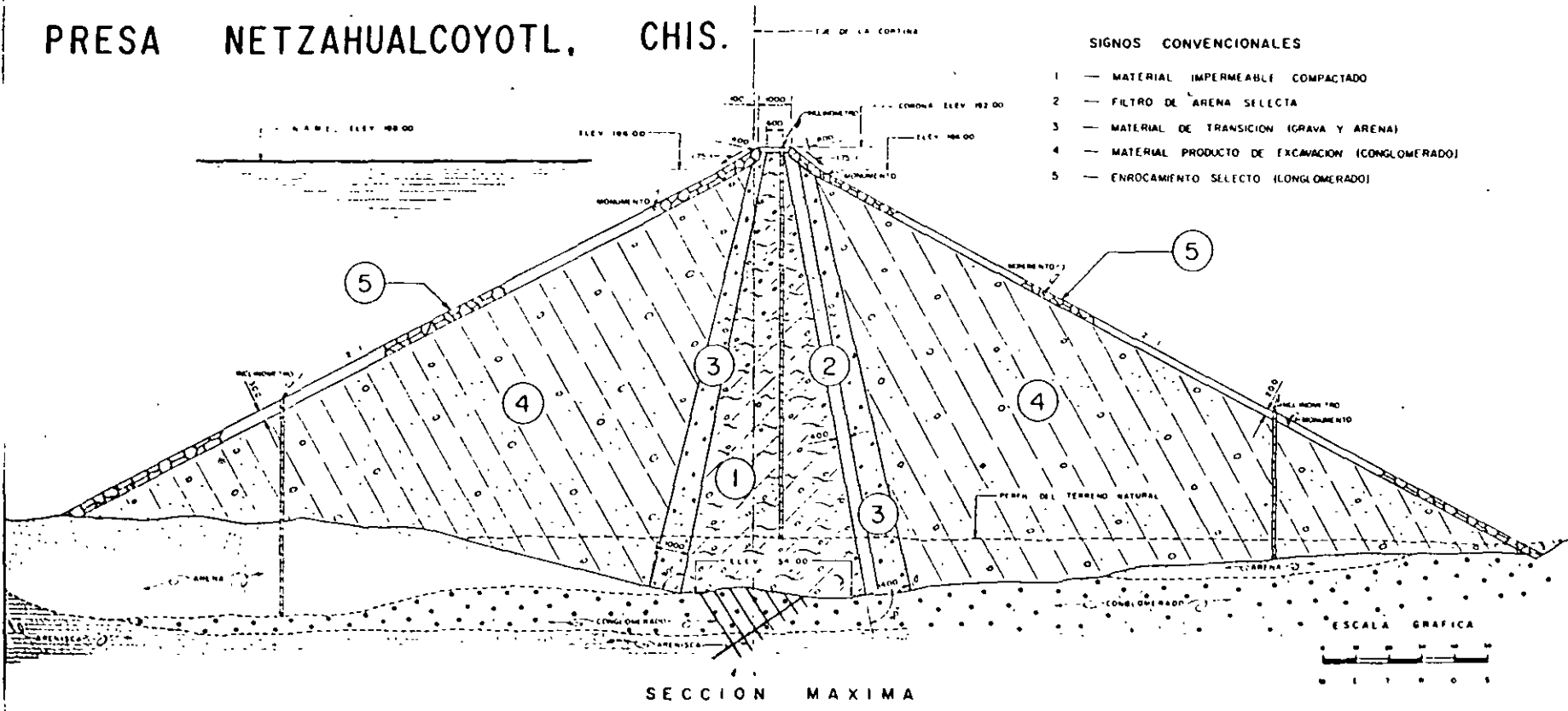

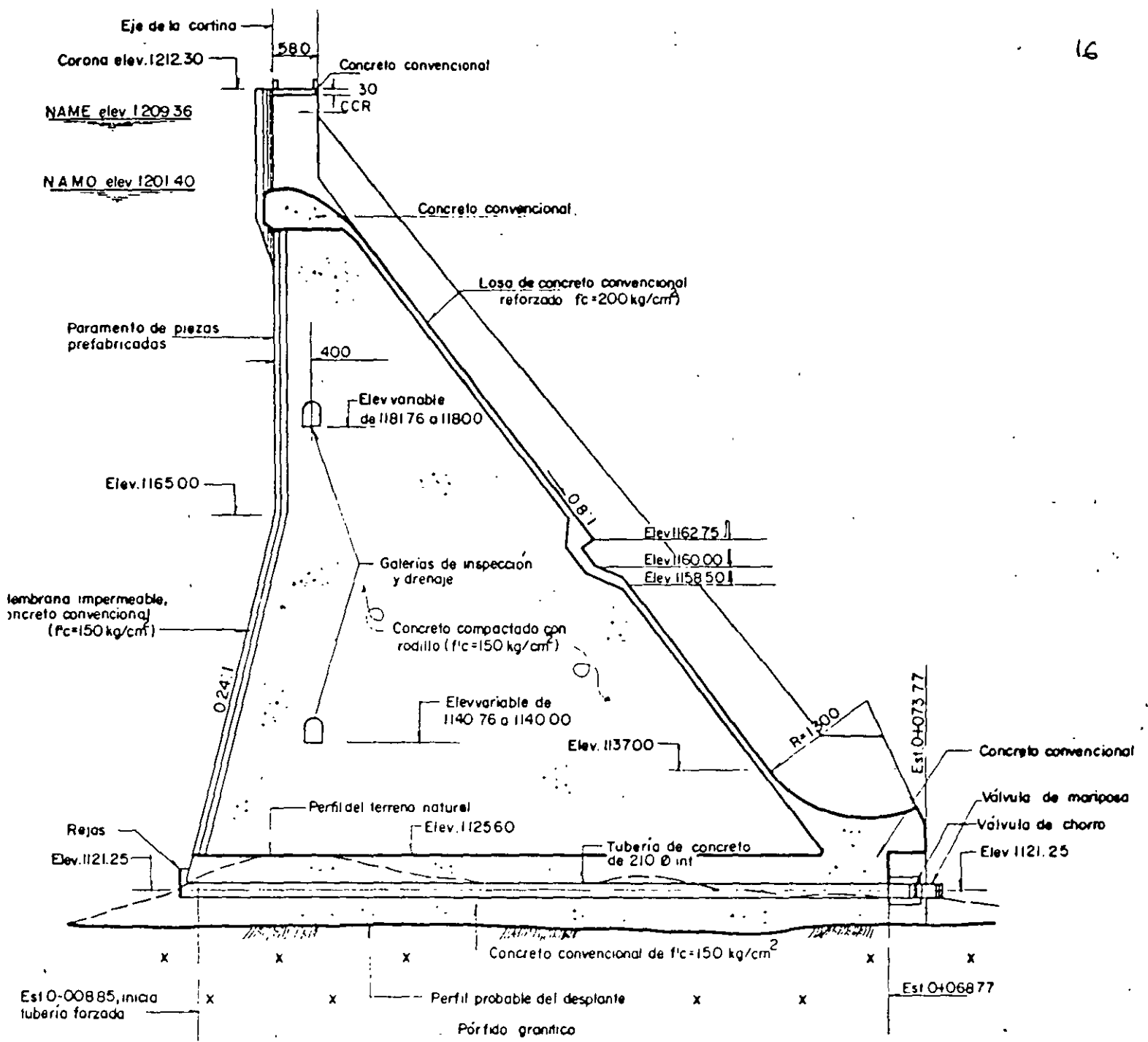

CORTE POR EL EJE DE LA OBRA DE TOMA

DATOS DE PROYECTO	
Capacidad total	324 000 000 m
Capacidad de conservación	250 000 000 m
Capacidad de superalmacenamiento	74 000 000 m
Capacidad para azolves	25 000 000 m
Elevación de la corona	1 212.30 m
Elevación del NAME	1 209.36 m
Elevación de la cresta vertedora	1 201.40 m
Elevación del nivel mínimo de operación	1 164.20 m
Elevación del umbral de la toma	1 151.50 m
Longitud de la cresta vertedora	75.00 m
Gasto máximo de entrada	4 600.00 m ³ /seg

OBRAS DE TOMA

DEFINICION.

Se llama obra de toma, al conjunto de estructuras construidas en una presa, con objeto de extraer el agua en forma controlada y estar en condiciones de satisfacer las demandas para el fin que haya sido proyectado el almacenamiento.

TIPOS.

Hay varios tipos de obras de toma y para la elección de uno de ellos o una combinación de los mismos, hay que tomar en cuenta una serie de factores que dan lugar a su clasificación, como sigue:

1. Según el fin para el cual se destine.
 - a) Para abastecimiento (Agua potable o Usos industriales)
 - b) Para riego
 - c) Para generación
 - d) Combinadas o mixtas.
2. Según su forma de operación.
 - a) De operación en la entrada
 - b) De operación intermedia
 - c) De operación en la salida
3. Según su estructura de entrada.
 - a) De torre con puente de acceso
 - b) De estructura de rejillas sumergida
4. Según el conducto.
 - a) De conducto excavado y colado a cielo abierto
 - b) De túneles excavados en las laderas
 - c) Integrado a la cortina.

5. Según su estructura disipadora
- a) De tanque amortiguador
 - b) De cámaras disipadoras
 - c) De concentradores de chorro.

De acuerdo con el Tipo o combinación de tipos elegidos, será la forma como trabajen desde el punto de vista hidráulico y estructural cada una de sus partes.

Ejemplos:

FACTORES QUE DETERMINAN EL TIPO DE OBRA DE TOMA.

Como ya se indicó con anterioridad, existe una variedad de tipos de obras de Toma o combinación de los mismos, en presas de almacenamiento. Para la elección del tipo más adecuado o un proyecto determinado habrá que hacer una serie de análisis que estarán en función de las características del proyecto en cuestión.

En una forma muy general, se puede decir que los factores principales que determinan el tipo de obra de toma, son:

1. Tipo de Cortina
2. Objeto del aprovechamiento
3. Gasto de extracción
4. Tipo de obra de desvío
5. Carga disponible
6. Topografía del sitio
7. Geología del sitio
8. Necesidades de operación
9. Factibilidad económica.

PARTES DE QUE CONSTA UNA OBRA DE TOMA

Las partes principales de que consta una obra de toma, son

- a) Estructura de entrada (de rejas y rejillas)
- b) Transiciones
- c) Conductos
- d) Dispositivos de Control y cierre
- e) Disipadores de energía

Funcionamiento Hidráulico.

El estudio del funcionamiento hidráulico de las Obras de Toma, se hace con objeto de determinar las dimensiones de los distintos elementos que las componen, como son:

- Rejillas
- Estructuras de rejas o torre
- Conductos
- Lumbreras
- Compuertas y válvulas
- Estructuras disipadoras

El funcionamiento hidráulico, debe estudiarse para las distintas condiciones de trabajo a que vaya a estar sujeta la obra de toma.

En el estudio hidrológico que sirve de base para el dimensionamiento de la presa en general, es decir, para determinar las diferentes capacidades de que consta según el fin para el que esté destinada, se encuentra la "La Ley de Demandas" de la que puede obtener el gasto de diseño de la obra de Toma.

Ejemplo:

2. Se denomina nivel del volumen muerto, a la elevación que corresponde el umbral de la toma en la curva de "Capacidades".

C. Estructuras de Entrada.

1. Rejillas

a) Velocidad del agua.

La velocidad del agua a través de las rejillas no será mayor de 0.60 m/s. cuando no tenga la seguridad de que en ningún momento el nivel del agua baje hasta descubrir las rejillas, este valor se puede aumentar, pero en ningún caso será mayor de 1.00 m/s.

b) Diseño de las rejillas.

Las soleras de las rejillas se diseñan a la ruptura, suponiéndolas totalmente obturadas y con la mitad de la carga máxima de agua que vayan a tener sobre ellas, pero nunca será mayor que 12.00 m, ni menor que 6.00 m (Fig. 2)

2- Estructura de rejillas.

- a) para el diseño de la estructura que soporta las rejillas (estructura de entrada o torre), se acepta que los esfuerzos admisibles se incrementan en un 50%.
- b) En todos los casos, las rejillas deberán fallar, con un margen considerable, antes que falle la estructura que las soporta.

OBRA DE TOMA BAJA

PRESA "LAS ADJUNTAS", TAMPS.

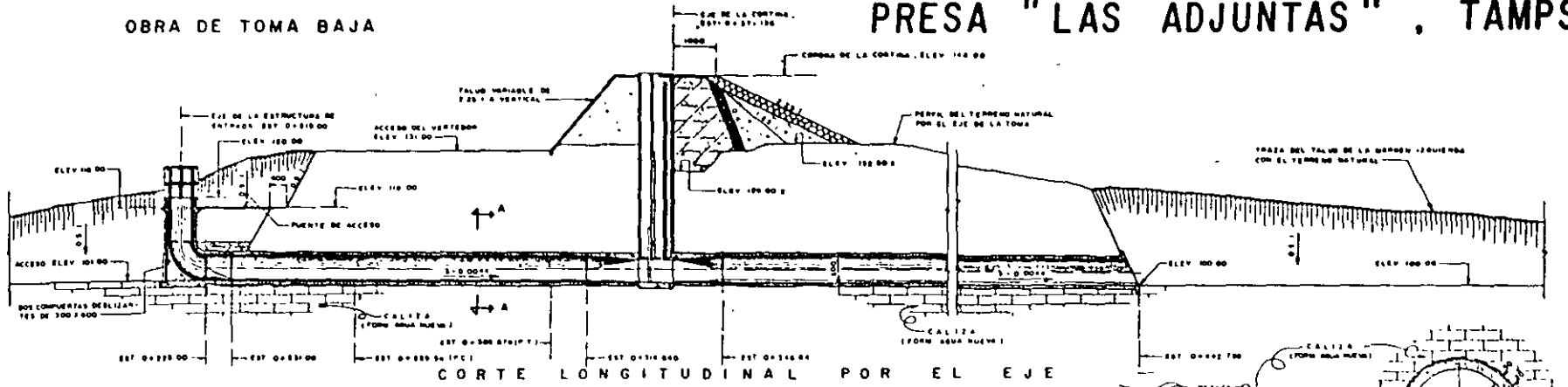

CORTE LONGITUDINAL POR EL EJE

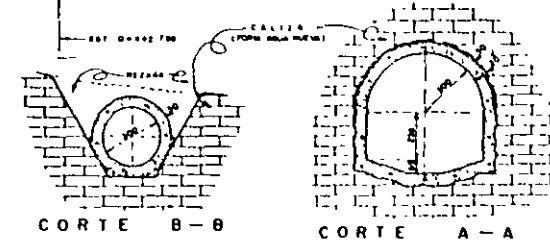

CORTE B-B CORTE A-A

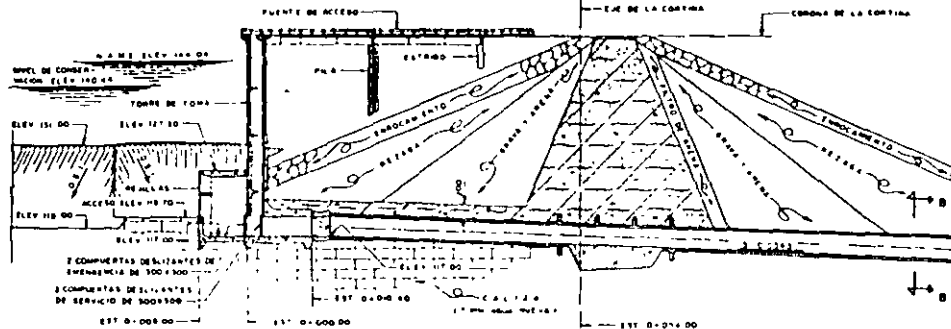

CORTE LONGITUDINAL POR EL EJE

OBRA DE TOMA ALTA

P R E S A

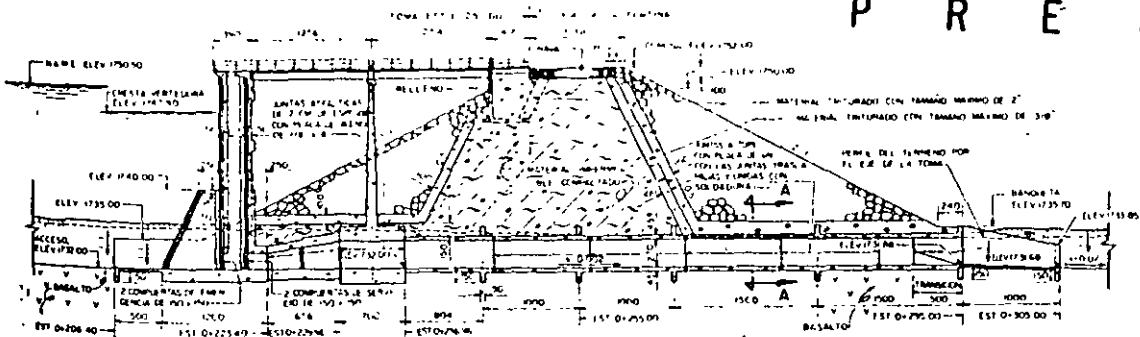

CORTE POR EL EJE

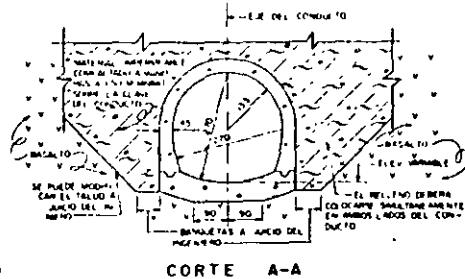

CORTE A-A

OBRA DE TOMA

UREPETIRO, MICH.

PRESA SOLIS, GTO.

DATOS GENERALES	
CAPACIDAD TOTAL	800 000 000 m ³
CAPACIDAD PARA AZÚVES	55 000 000 m ³
CAPACIDAD UTR	745 000 000 m ³
SUPERALMACENAMIENTO	180 000 000 m ³
CAPACIDAD PARA RIEGO	687 000 000 m ³
ELEVACION CORONA	1896.70 m
ELEVACION NIVEL AGUAS BAJAS	1883.75 m
ELEVACION NIVEL DE LA CRESTA	1890.75 m
LONGITUD LIBRE DE LA CRESTA	135.00 m
CAPACIDAD DE LA OBRA DE TOMA	90 CU M ³ /seg
CAPACIDAD DEL VEREDOR	1380 CU M ³ /seg

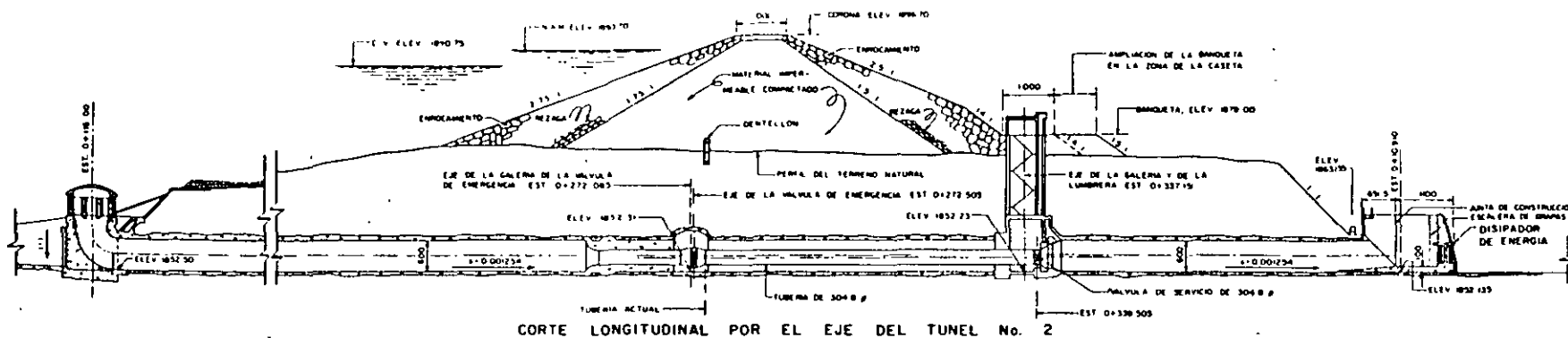
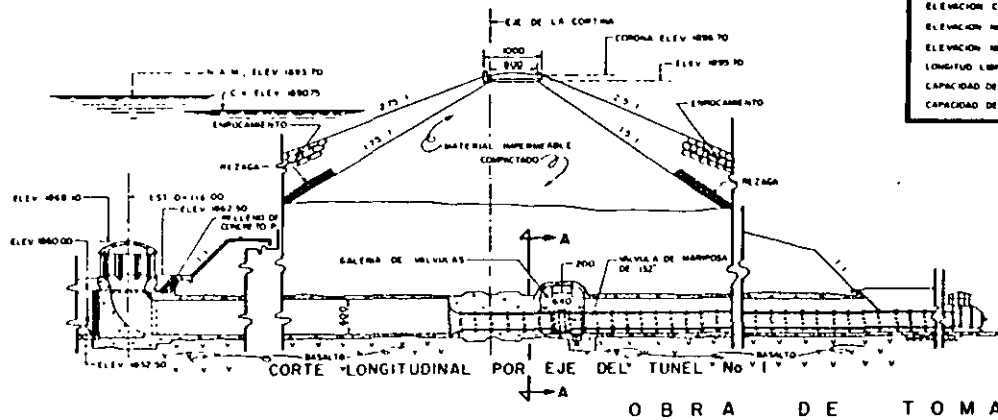
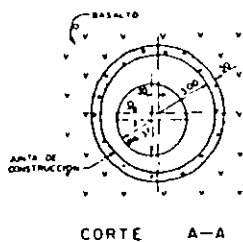

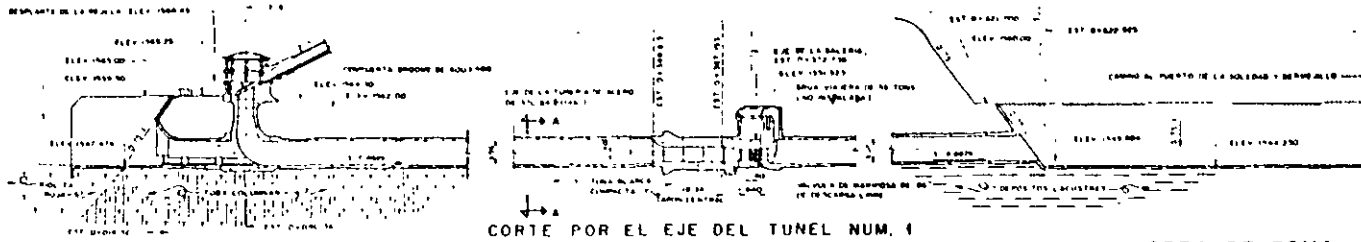

CORTE POR EL EJE DEL TUNEL NUM. 1

OBRA DE TOMA

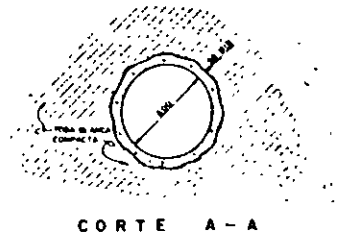

CORTE A-A

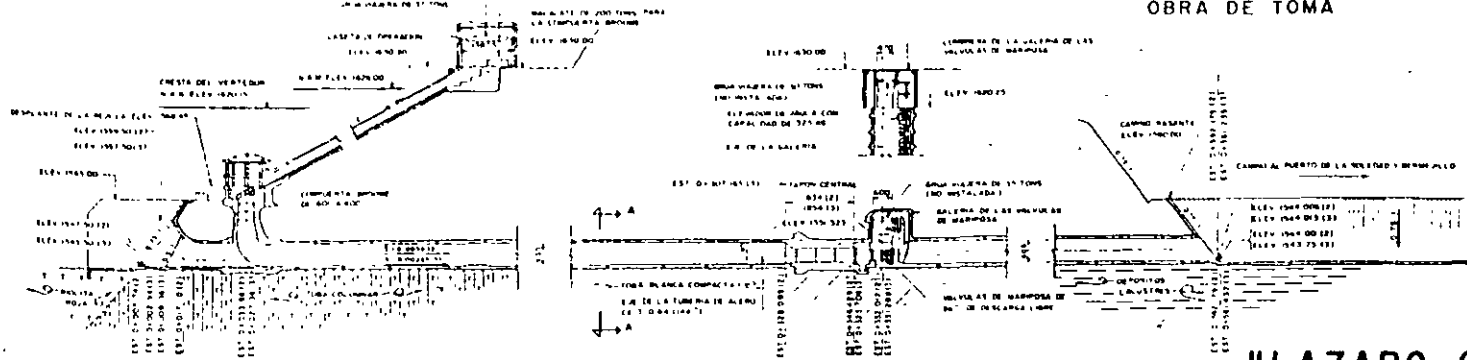

CORTE POR LOS EJES DE LOS TUNELES NUMS 2 Y 3

"LAZARO CARDENAS", DGO.

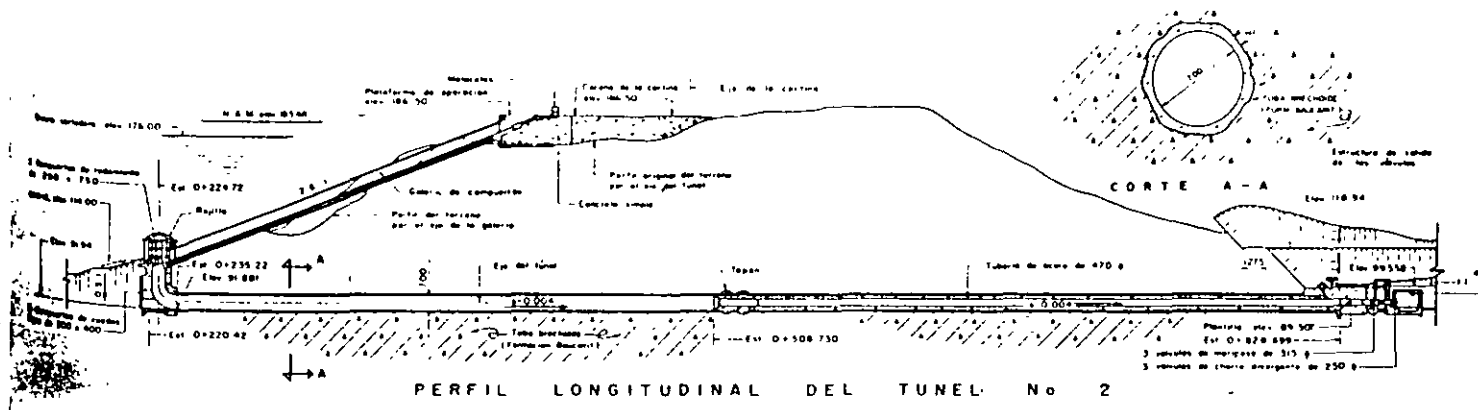

PERFIL LONGITUDINAL DEL TUNEL No. 2

OBRA DE TOMA

PRESA PRESIDENTE
 ADOLFO LOPEZ MATEOS, SIN.
 (EL HUMAYA)

PRESA "LA SOLEDAD", GTO.

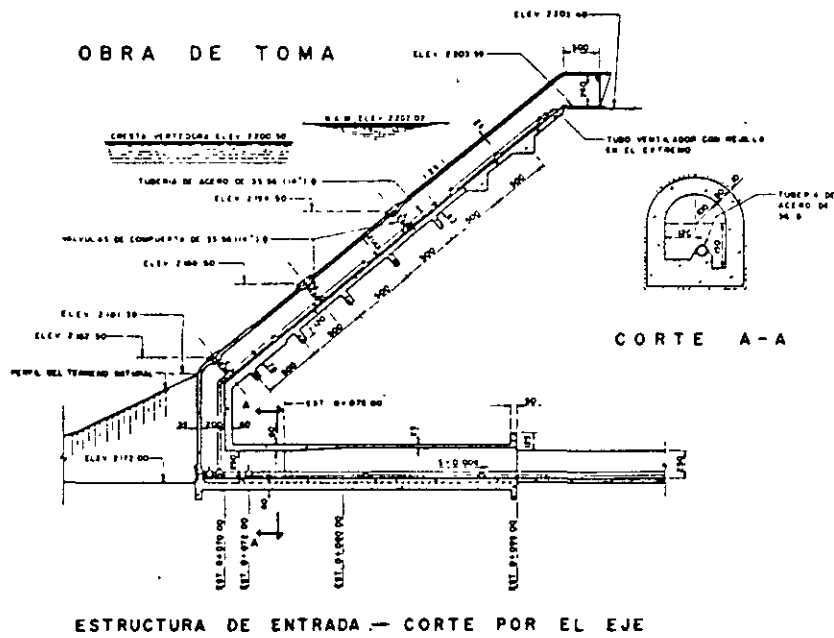

OBRAS DE EXCEDENCIAS (VERTEDORES)

La obra de excedencias, viene a ser la válvula de seguridad de una presa ante avenidas que se presentan en las condiciones mas desfavorables como es el caso en que el almacenamiento se encuentre lleno al NAMO.

Las obras de excedencias se dimensionan para que transite por el vaso la avenida máxima probable sin que cause daños a la presa por lo que su diseño en general deberá realizarse con base aun estudio hidrológico confiable.

Según estadísticas a nivel mundial, la falla de presas de tierra por incapacidad del vertedor, es de las más socorridas.

En este aspecto también es muy importante la determinación del Bordo Libre.

TIPOS DE OBRAS DE EXCEDENCIAS.

Como en todas las estructuras que integran una presa, existen muchos tipos y combinación de los mismos en obras de excedencias, que como las cortinas y las obras de toma, están en función de una serie de factores que los determinan.

Se han hecho diseños especiales para casos muy particulares como los que sin tener mecanismos de control, descargan un gasto constante independiente de la carga hidrostática (a base de geometría).

A manera de ejemplo, enseguida se muestra una serie de variantes que en cada caso, estará en función de:

- Hidrología
- Topografía
- Geotecnia
- Geología
- Objetivo del almacenamiento

- Funcionamiento hidráulico
- Operación.

- OBRA DE EXCEDENCIAS
- DE PLANTA RECTA
 - DE PLANTA CURVA
 - CRESTA LIBRE
 - CRESTA CONTROLADA
 - DESCARGA EN CANAL
 - DESCARGA EN TUNEL
 - DISIPADOR EN SALTO DE SKY
 - DISIPADOR EN TANQUE AMORTIGUADOR
 - MORNING GLORY

PARTES QUE INTEGRAN UNA OBRA DE EXCEDENCIAS.

1. Canal de llamada
2. Obra de control
3. Canal colector
4. Canal de descarga (o túnel)
5. Estructura disipadora.

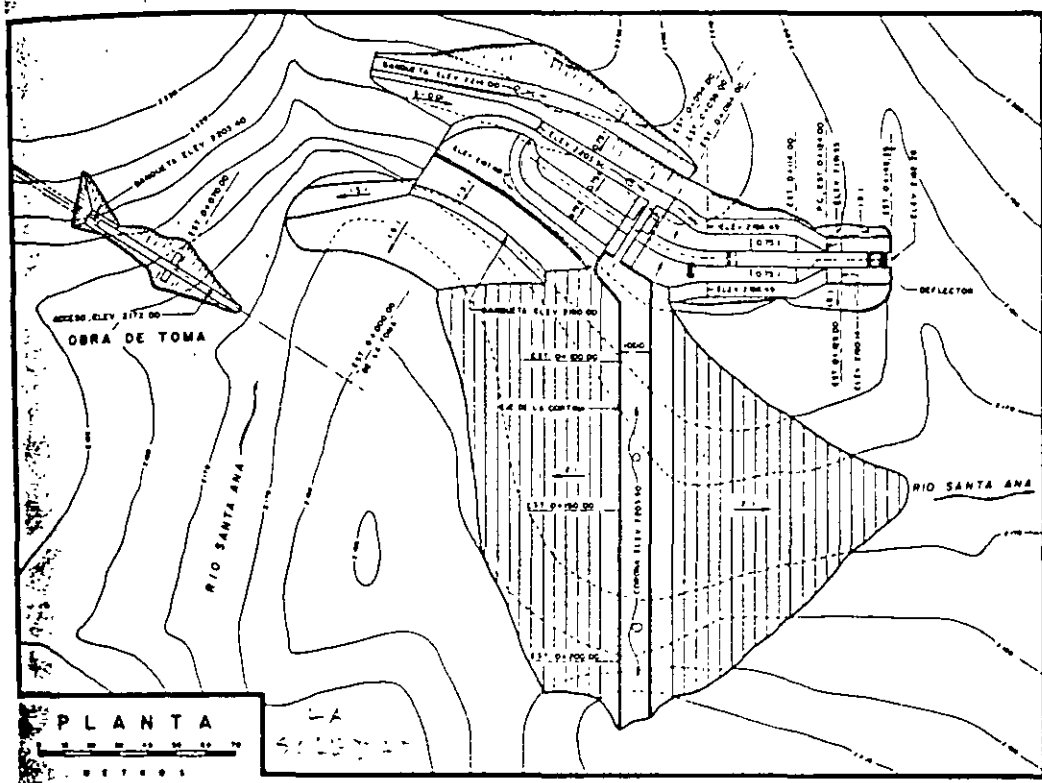
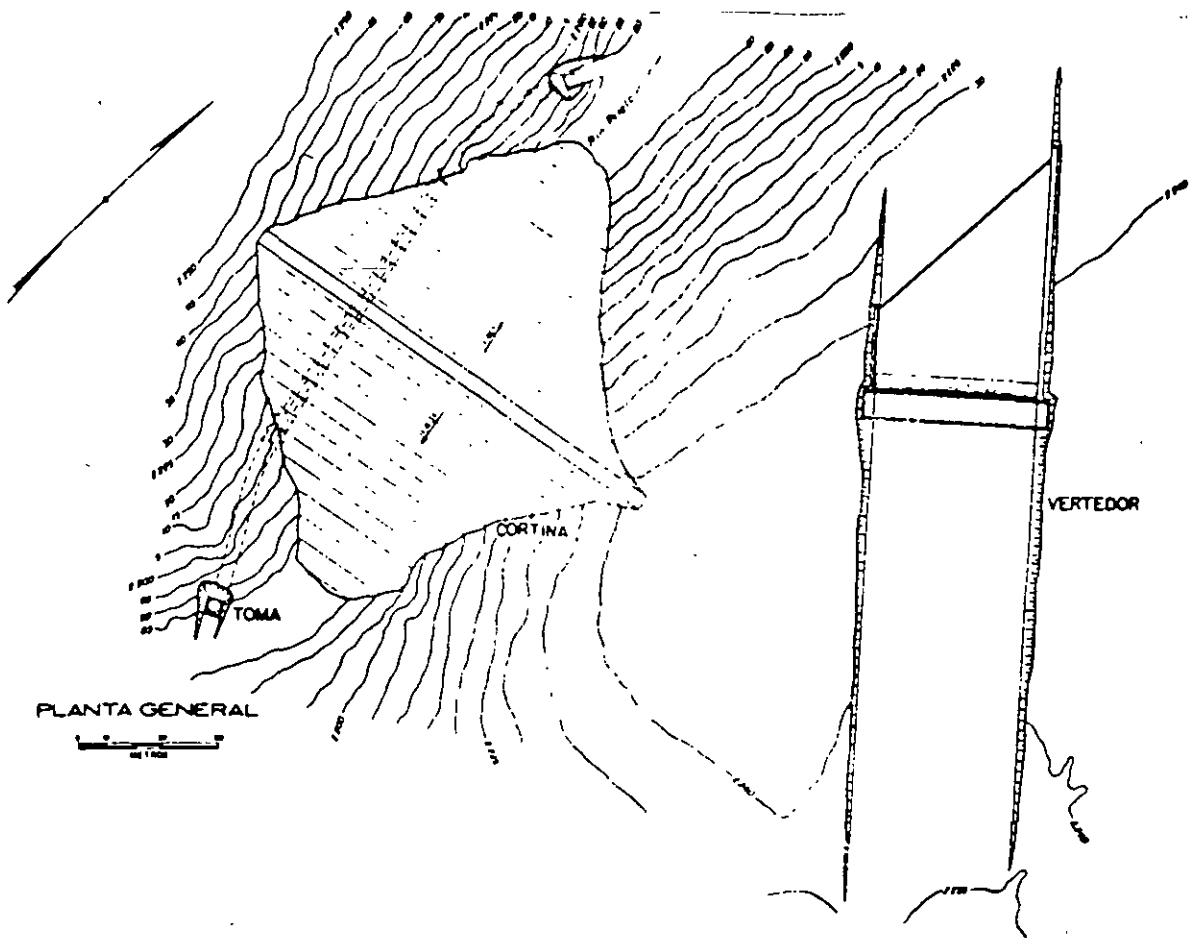

P. LA SOLEDAD.

PRESA DE TACOTAN, JAL.

P L A N T A

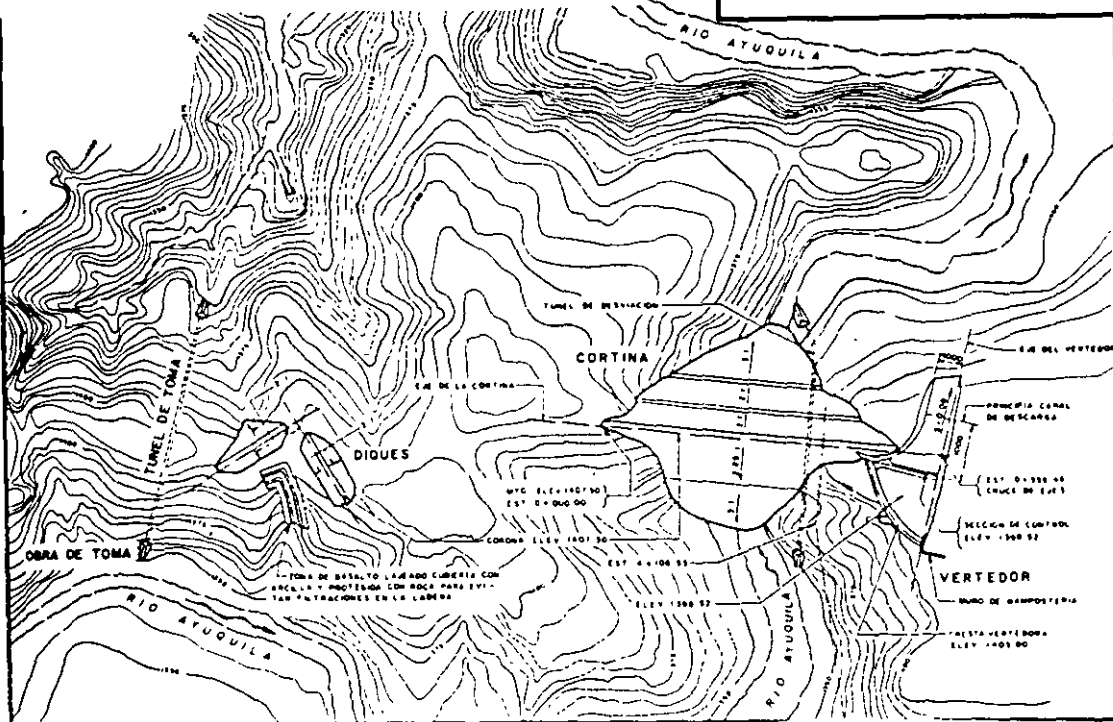
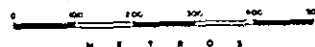

VERTEDOR

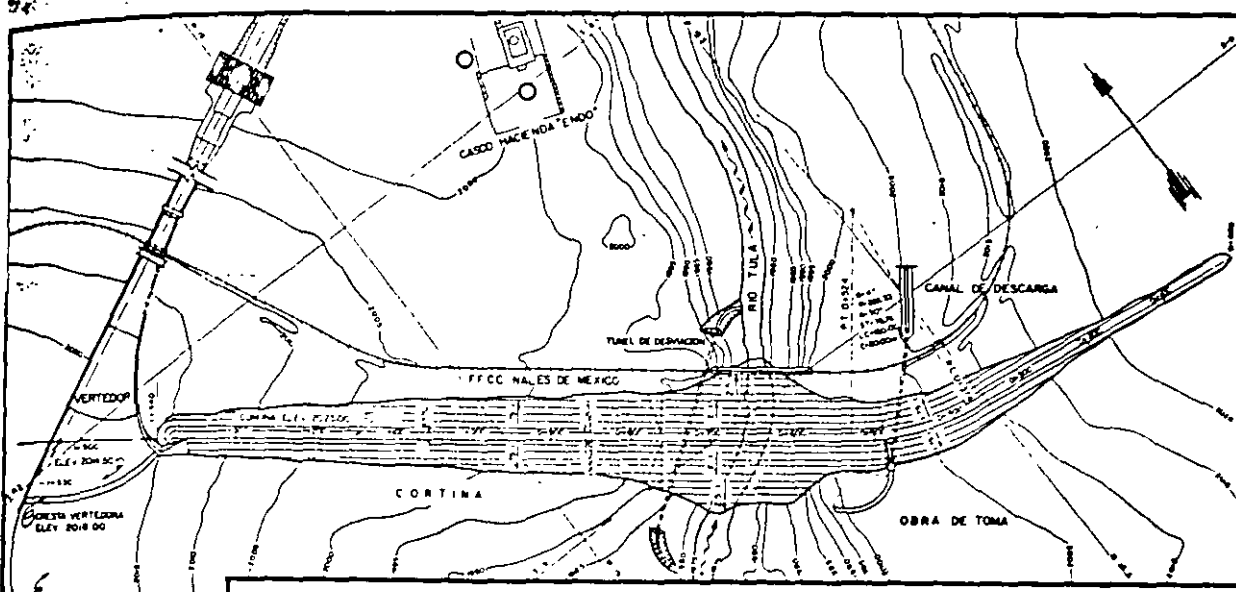
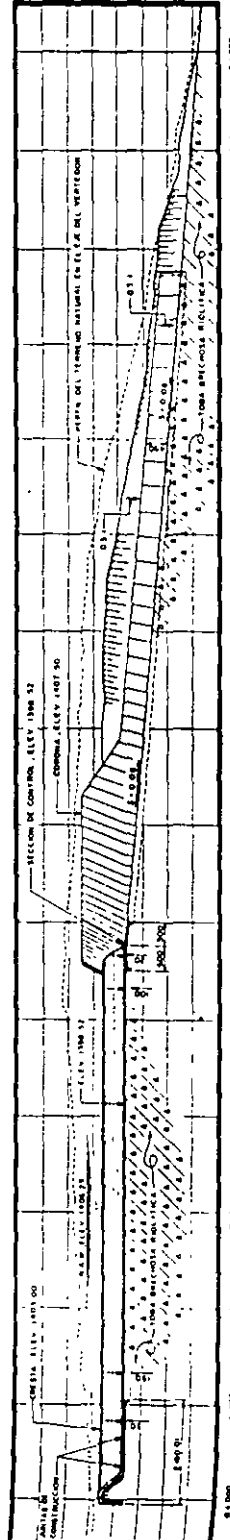

PRESA DE ENDO

PRESA NETZAHUALCOYOTL, CHIS. (MALPASO)

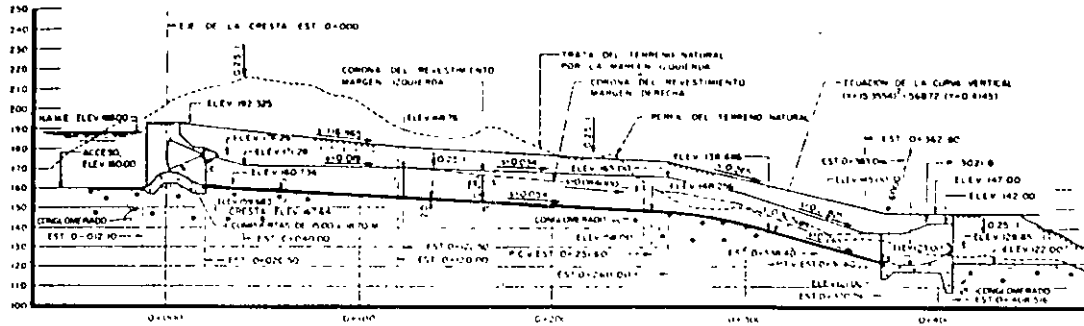

CORTE LONGITUDINAL
VERTEDOR DE EMERGENCIA

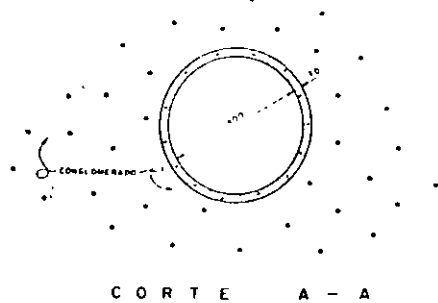

CORTE A - A

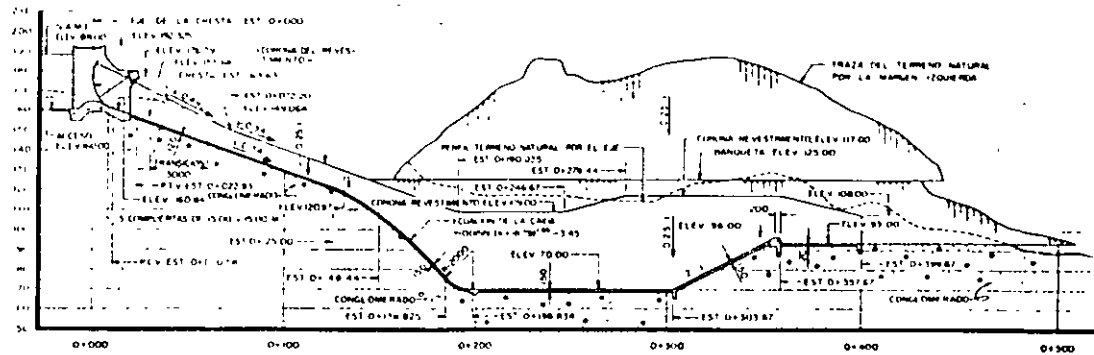

CORTE LONGITUDINAL
VERTEDOR DE SERVICIO

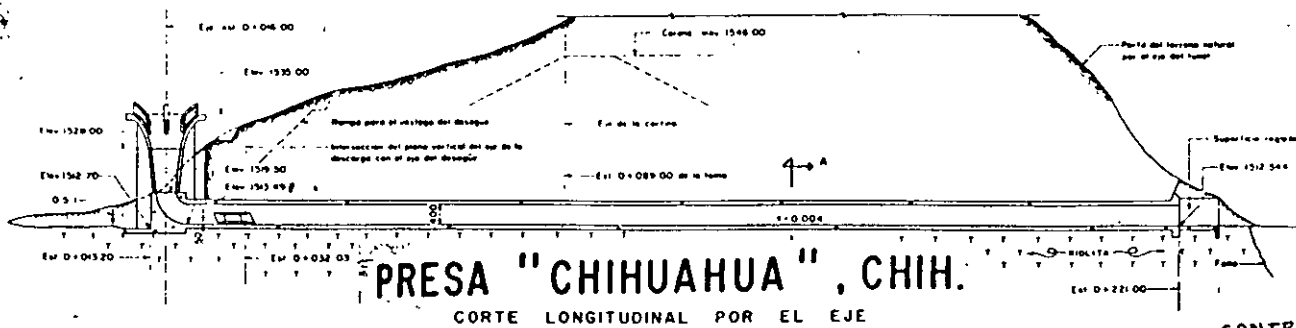

PRESA "CHIHUAHUA", CHIH.

CORTE LONGITUDINAL POR EL EJE

CONTROL
OBRA DE ~~ESTRUCTURA~~

VERTEDOR

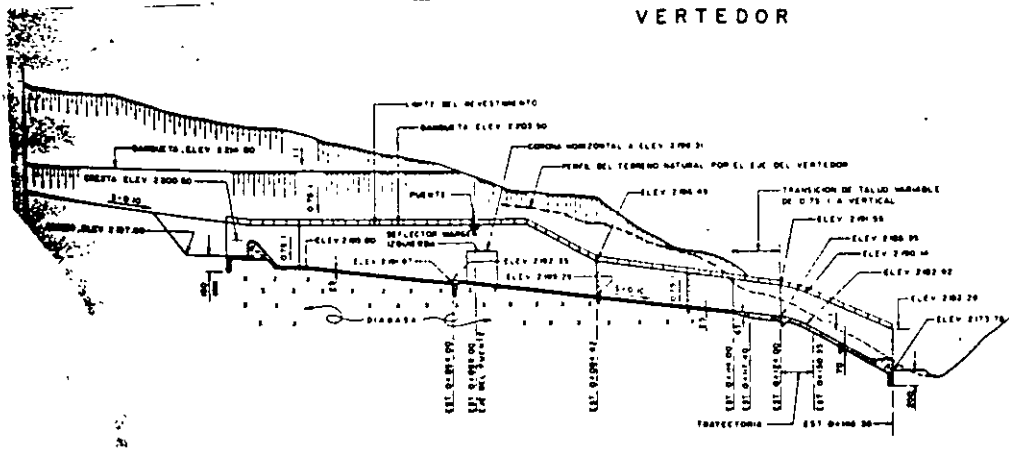

CORTE LONGITUDINAL POR EL EJE

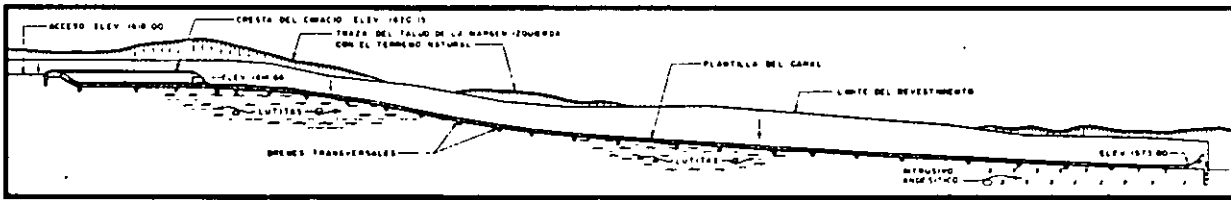

CORTE LONGITUDINAL

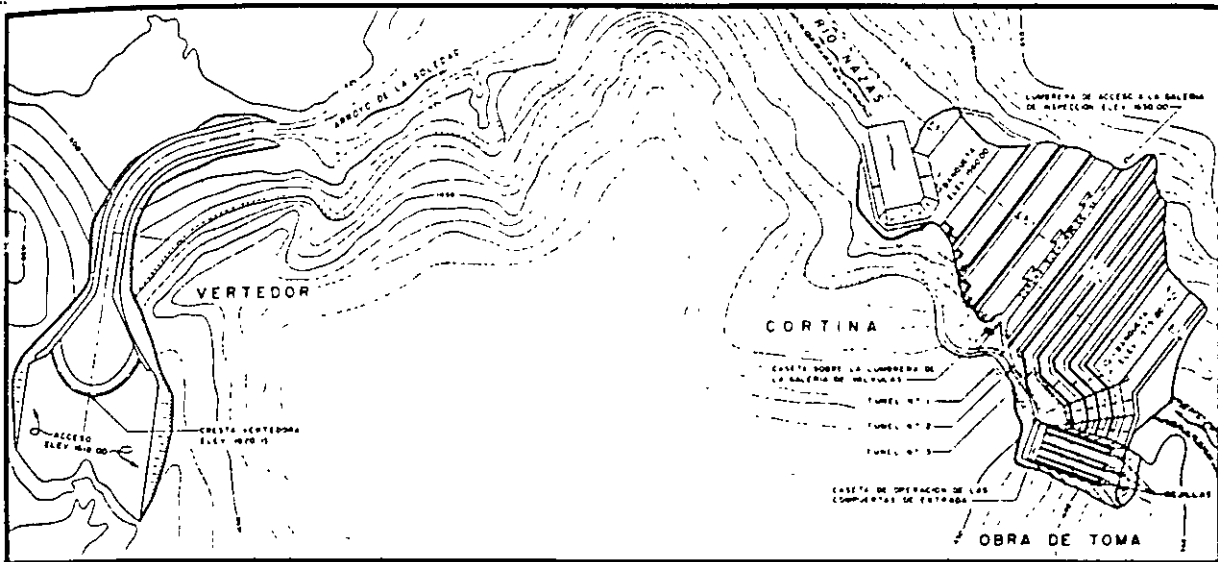

"LAZARO CARDENAS", DGO.

CIERRE DE UNA PRESA

Se denomina CIERRE DE UNA PRESA, a una serie de acciones y actividades que hay que llevar al cabo, para terminar la construcción y la obra inicie su operación normal.

En realidad se trata de "dos" cierres diferidos en tiempo, uno, completar la construcción con el desvío de cierre funcionando y el otro, el cierre definitivo de este desvío o sea la fecha en que se inicia el almacenamiento cortando el escurrimiento de la corriente.

Es tan importante el CIERRE, que de esas actividades que duran meses escasos, depende el éxito de la construcción de toda la obra que puede ser de años, incluyendo los daños que esto pudiera generar.

Este programa debe ser elaborado por ingenieros con amplia experiencia en el manejo de maquinaria pesada, en rendimientos, en optimizar recursos materiales y humanos, de contar con equipos de reserva para mantener rendimientos altos, además de formar equipo con ingenieros hidrólogos e hidráulicos para elegir las fechas de los cierres, elaborando programas generales y de detalle, con tiempos reales (sin holguras) para concluir en una fecha predeterminada que no admite retraso ya que a partir de allí, se pueden presentar avenidas en el vaso.

Se dice que en los cierres de presas no hay marcha atrás, una vez que se define el programa y se toma la decisión, no tiene cabida el regreso.

CORTINA DE MATERIALES GRADUADOS
- ETAPAS DE CONSTRUCCION -

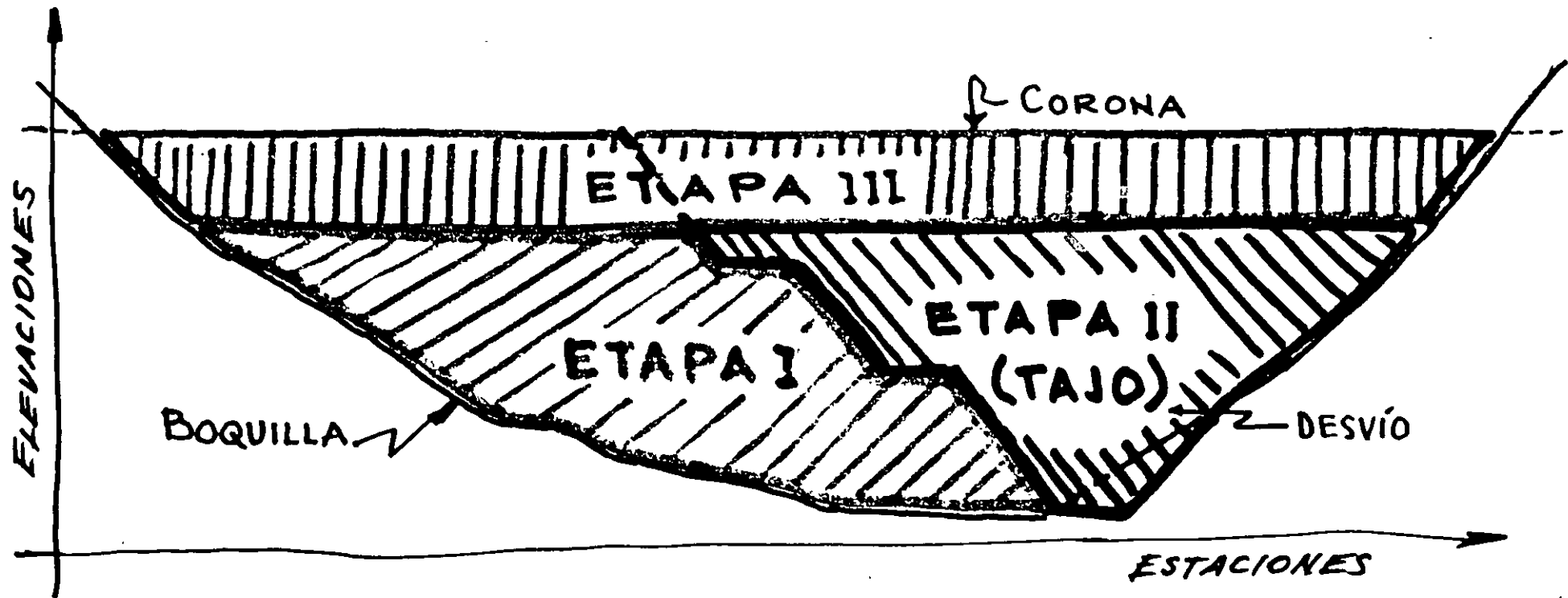

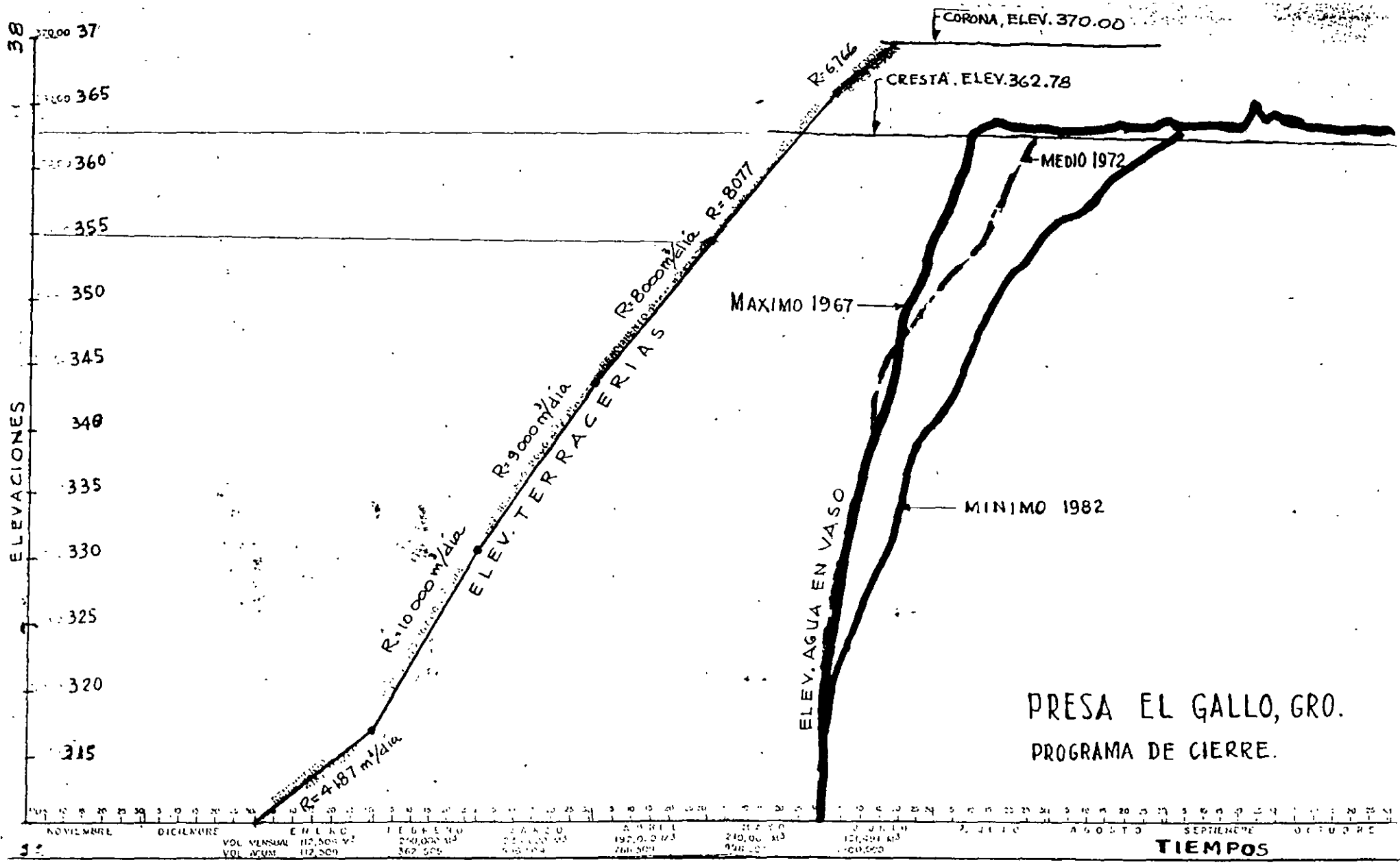

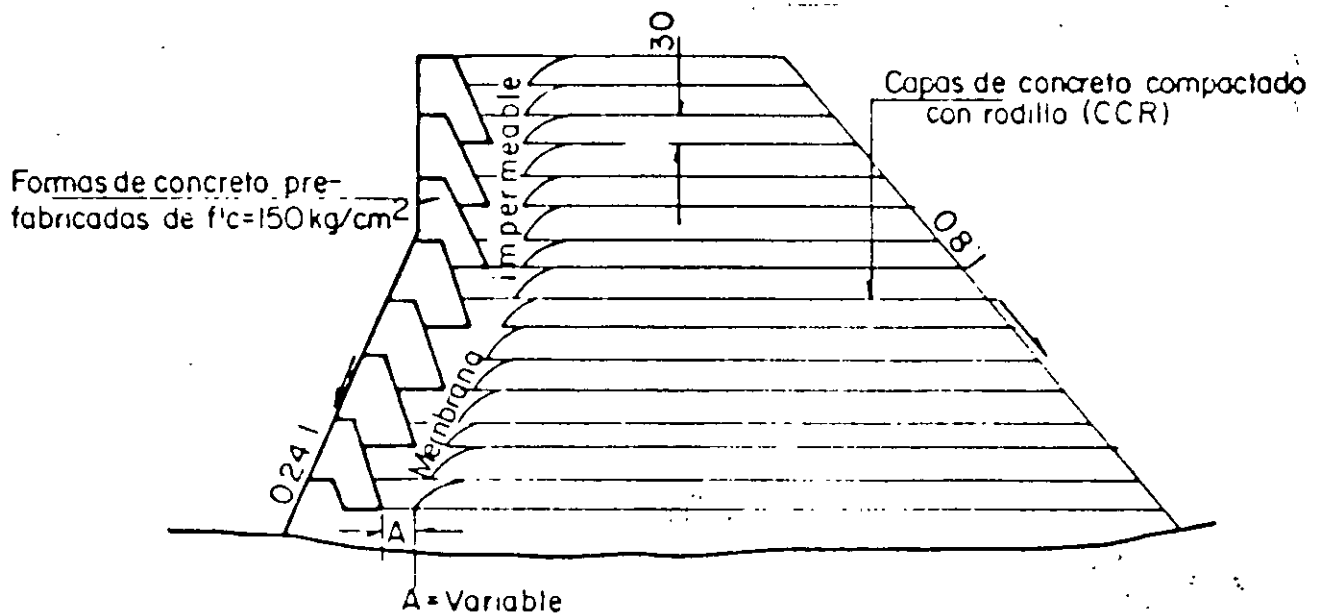

DETALLE DEL PROCESO DE COLOCACION DE CAPAS DE CONCRETO RODILLADO

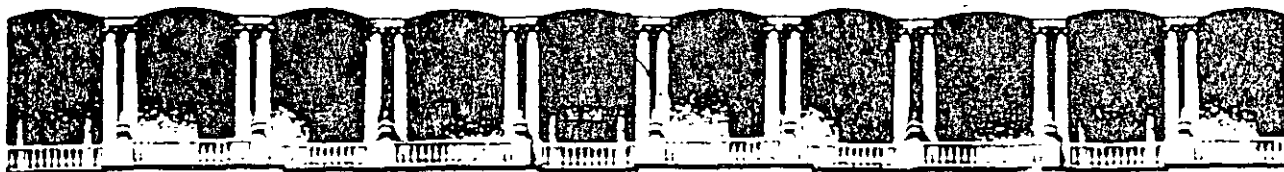

FACULTAD DE INGENIERIA U.N.A.M.
DIVISION DE EDUCACION CONTINUA

CURSOS INSTITUCIONALES

DIPLOMADO GERENCIA DE PROYECTOS
ICA-DECFI, UNAM

Módulo III "Suministros"
24, 25 y 26 de junio de 1999

"Presas de Tierra y Enrocamiento. Apuntes Generales"

Ing. Joel Rojas Tamez
Palacio de Minería
1999

PLANEACIÓN DE CONSTRUCCIÓN DE UNA PRESA CON HIDROELECTRICA.

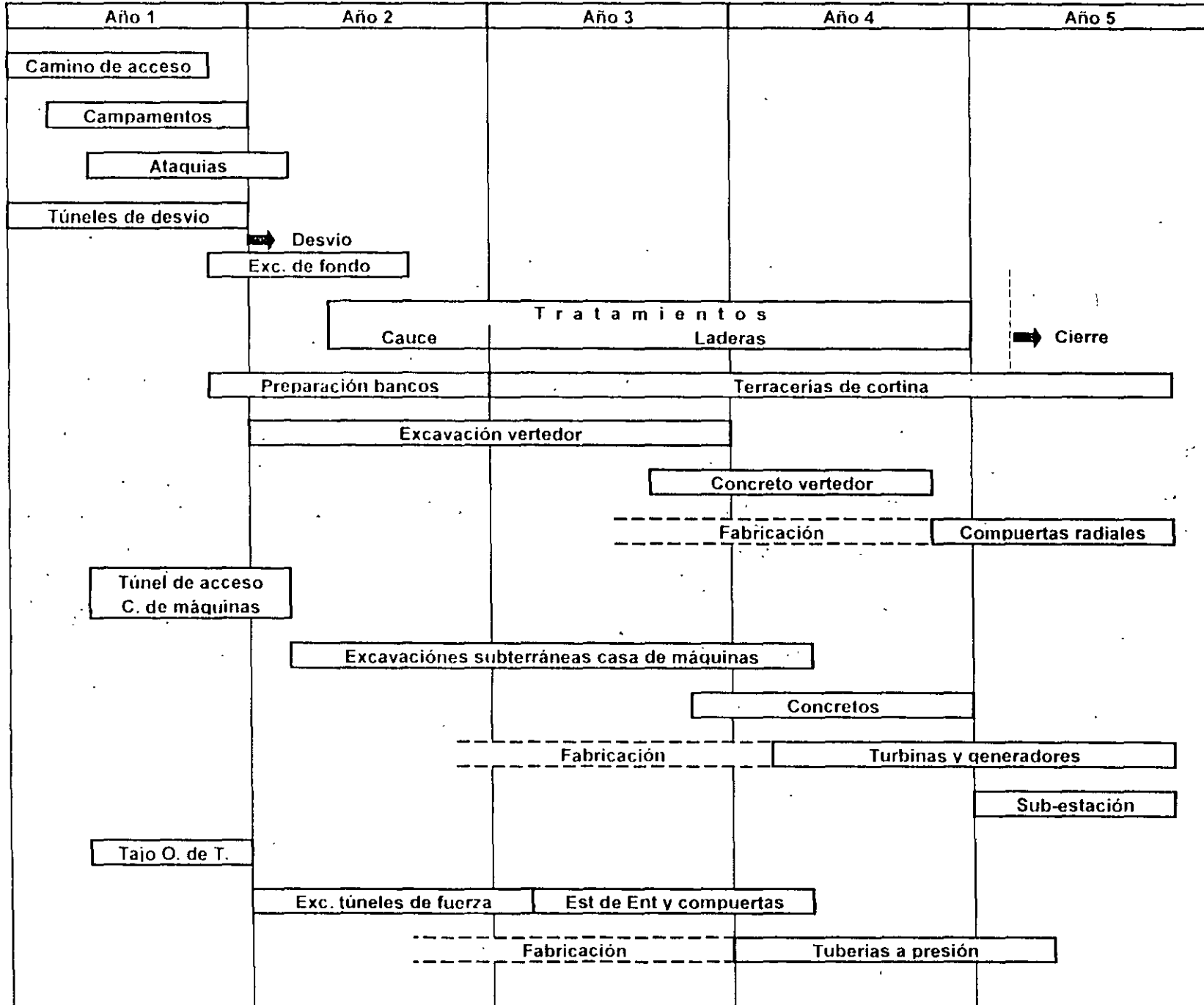

ORGANIGRAMA DE UNA RESIDENCIA DE CONSTRUCCION PARA UNA PRESA

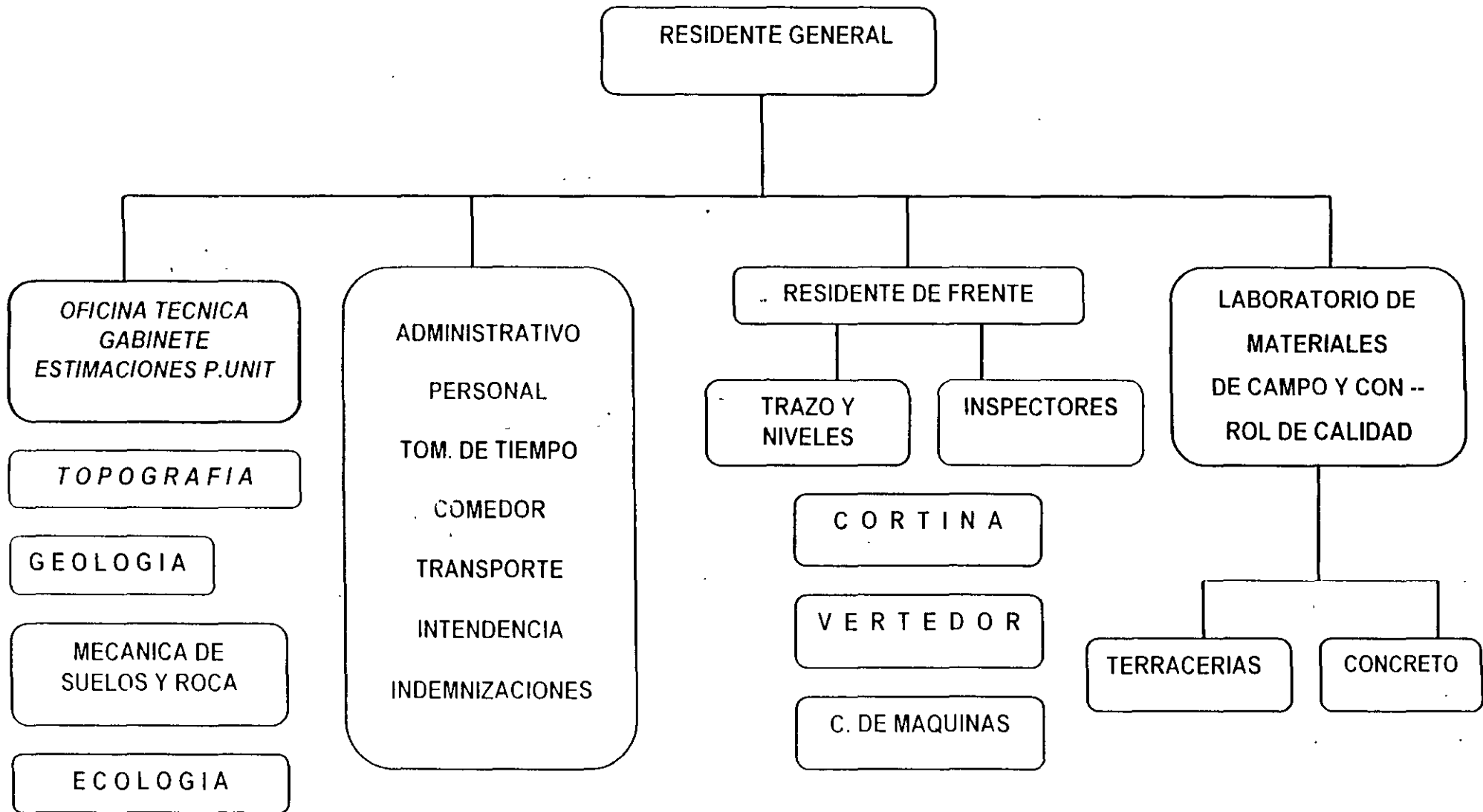

PRESAS CON CORTINA DE ENROCAMIENTO, EN MEXICO

Nombre	Localización	Año de terminación	Altura m	Taludes (x)		Ancho de Corona, m	Losas de Concreto	
				A. Ar.	A. Ab.		Arriba m	Abajo m
1. Taxhimay	Edo. de Hidalgo	1912 1934	43	0.75:1	1.4:1	4	0.20	0.40
2. Tacubaya	Distrito Federal	1938	26	1.4:1	1.4:1	5	----	----
3. Madero	Edo. de Hidalgo	1939	52	1.2:1	1.4:1	5	----	----
4. El Girón	Edo. de Hidalgo	1940	20	1.4:1	1.4:1	4	----	----
5. Mixcoac	Distrito Federal	1941	32	1.2:1	1.4:1	5	----	----
6. San Ildefonso	Edo. de Querétaro	1942	62	1.4:1	1.4:1	5	0.20	0.52
7. La Esperanza	Edo. de Hidalgo	1943	27	1.3:1 1.4:1	1.4:1	5	----	----
8. Colorines	Edo. de México	1944	32	1.4:1	1:1 1.3:1	6	----	----
9. Gonzalo N. Santos	Edo. de S.L.P.	1949	39	1.4:1	1.4:1	4.5	----	----
10. Ixtapantongo	Edo. de México	1950	28	1:1	1.5:1	3.5	----	----
11. Los Pinzales	Edo. de México	1957	59	1.2:1	1.4:1	5	----	----
12. Zicuirán	Edo. de México	1957	46	1.18:1 1.3:1 1.41:1	1.4:1	7	0.30	0.44
13. Texcalatlaco	Distrito Federal	----	----	----	----	----	----	----

(X) A. Ar= Aguas Arriba A. Ab= Aguas Abajo

AGUAMILPA

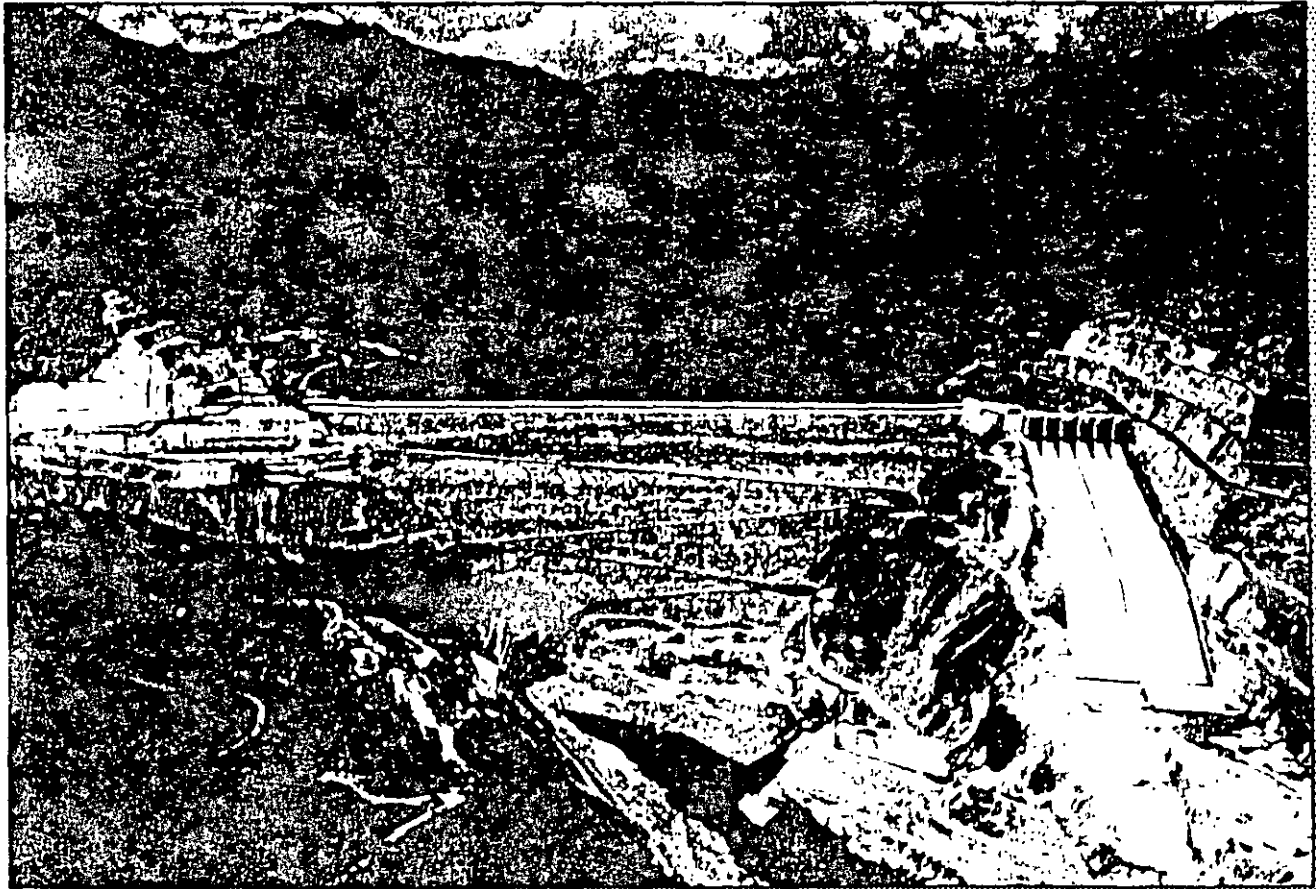

OBRAS CIVILES PRINCIPALES

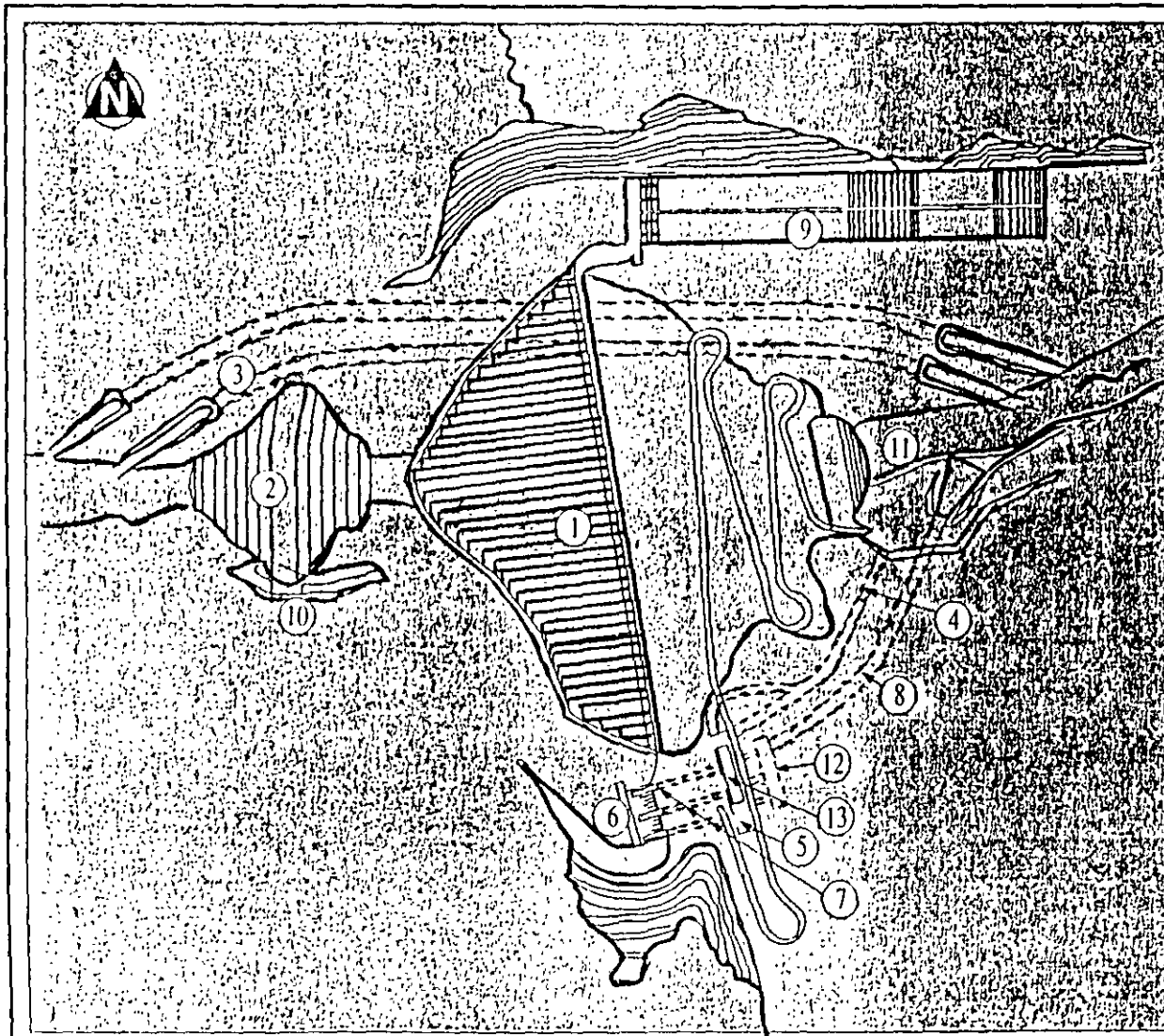

- 1 CORTINA
- 2 ATAGUIA AGUAS ARRIBA
- 3 TUNELES DE DESVIO
- 4 TUNEL DE ACCESO C.M.
- 5 CASA DE MAQUINAS
- 6 OBRA DE TOMA
- 7 TUBERIAS A PRESION
- 8 TUNEL DE DESFOGUE
- 9 OBRA DE EXCEDENCIAS
- 10 CANAL FUSIBLE
- 11 ATAGUIA AGUAS ABAJO
- 12 GALERIA DE OSCILACION
- 13 SUBESTACION

AGUAMILPA

INFORMACION TECNICA DE DISEÑO



HIDROLOGIA			Unidades		CORTINA			Unidades	
Area total de la cuenca	knf ²	75 651			Tipo				
Escurrencimiento medio anual	mill. m ³	6 948			Aluvion-Enrocamiento				
Gasto medio anual	m ³ /s	220.34			Elevación de la corona	msnm	235.0		
Gasto máximo registrado	m ³ /s	6 688			Longitud de la corona	m	642.0		
EMBALSE					Altura máxima	m	185.5		
NAME	msnm	232.0			Volumen total (incl. ataguías)	mill. m ³	14.0		
NAMO	msnm	220.0			OBRA DE EXCEDENCIAS				
NAMINO	msnm	190.0			Elevación de la cresta	msnm	210.0		
Capacidad total al NAME	mill. m ³	6 950			Longitud total de la cresta	m	72.0		
Capacidad control avenidas	mill. m ³	1 410			Gasto máx. de descarga total	m ³ /s	14 900		
Capacidad útil p/generar	mill. m ³	2 575			Compuertas radiales (No., l x a)	m	6-12x19.34		
DESFOGUE					Elev. labio superior compuertas	msnm	228.935		
Comp. deslizantes (No., l x a)	m	6-5.47x6.41			Gasto máx. (Avenida de diseño)	m ³ /s	17 482		
Elevación media	msnm	67.60			CONDUCCION				
OBRA DE TOMA					Conductos (No. y diámetro)	m	3-7.40		
Número de tomas		3			Longitud total	m	181.5		
Gasto máximo x toma	m ³ /s	240			Inclinación	grados	51°57'28"		
Compuertas rodantes (No., l x a)	m	3-5.8x7.4			TURBINAS				
CASA DE MAQUINAS					No. y tipo	3 Francis			
Tipo		Caverna			Marca	Jarkov-Turboatom			
Dimensión en ancho	m	22.80			Potencia máxima	MW	368		
Dimensión en largo	m	134.0			Gasto de diseño	m ³ /s	240		
Dimensión en altura máx.	m	50.0			Carga neta de diseño	m	145.10		
Grúas(s) viajera(s)(No., Cap.)	ton	2-405			Velocidad de rotación	rpm	150		
TRANSFORMADORES					GENERADORES				
No.		9			Marca	Electrosila			
Marca		Zaporozhe Transformator			Capacidad nominal	320 MW	MVA	341	
Tipo (No. de fases)		Monofásico			Tensión nominal		KV	13.8	
Capacidad nominal	MVA	125			Factor de potencia		%	95	
Clase de enfriamiento		OA/FA/FA			Frecuencia		Hz	60	
Tensión de transformación	KV	13.8/400			SUBESTACION				
l x a = largo x alto					Líneas, tensión/destino	KV	2-400. epic II		
					Capacidad instalada	960 MW			

CORTE LONGITUDINAL DEL VERTEDOR

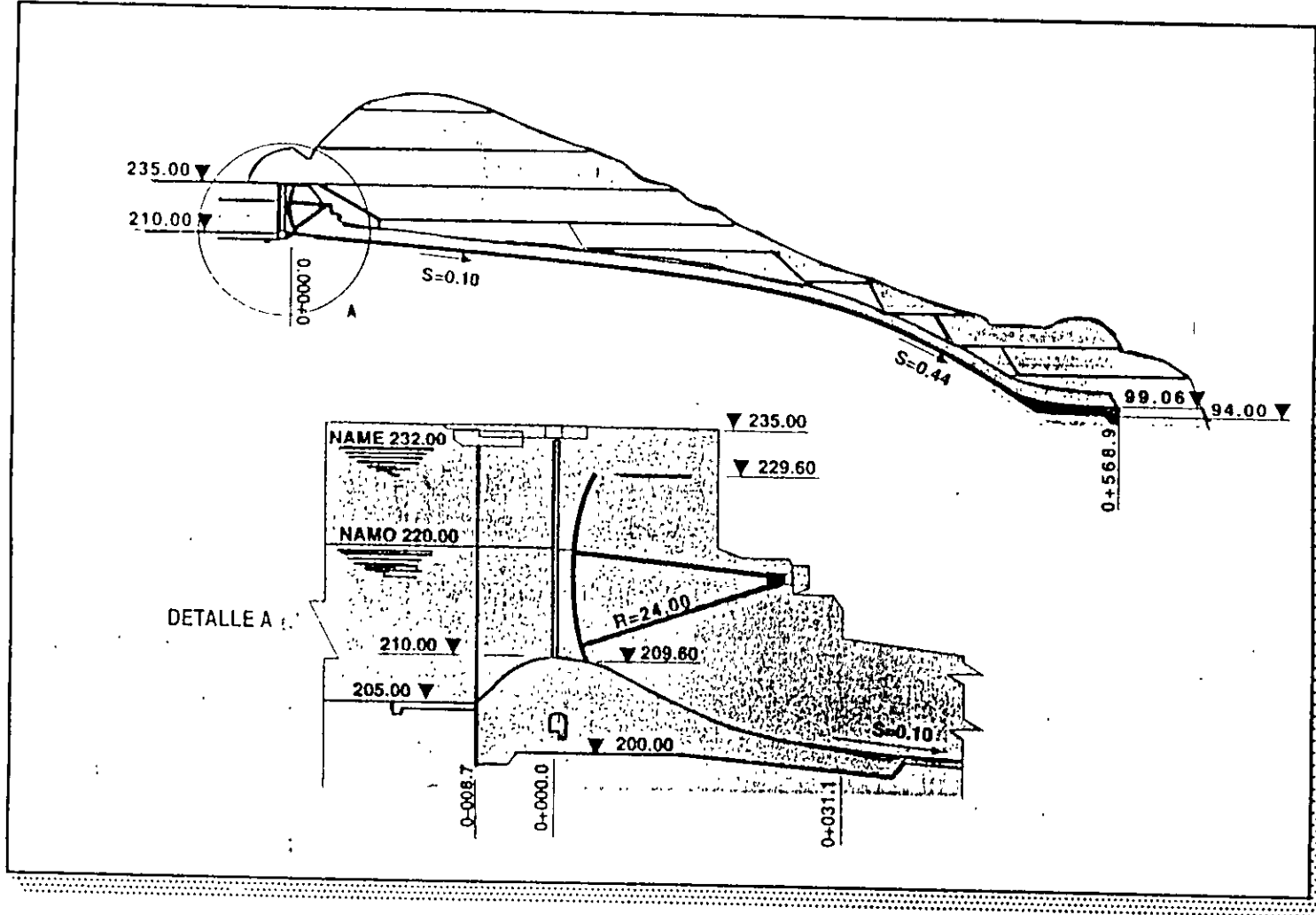

CORTE DE LA CONDUCCION

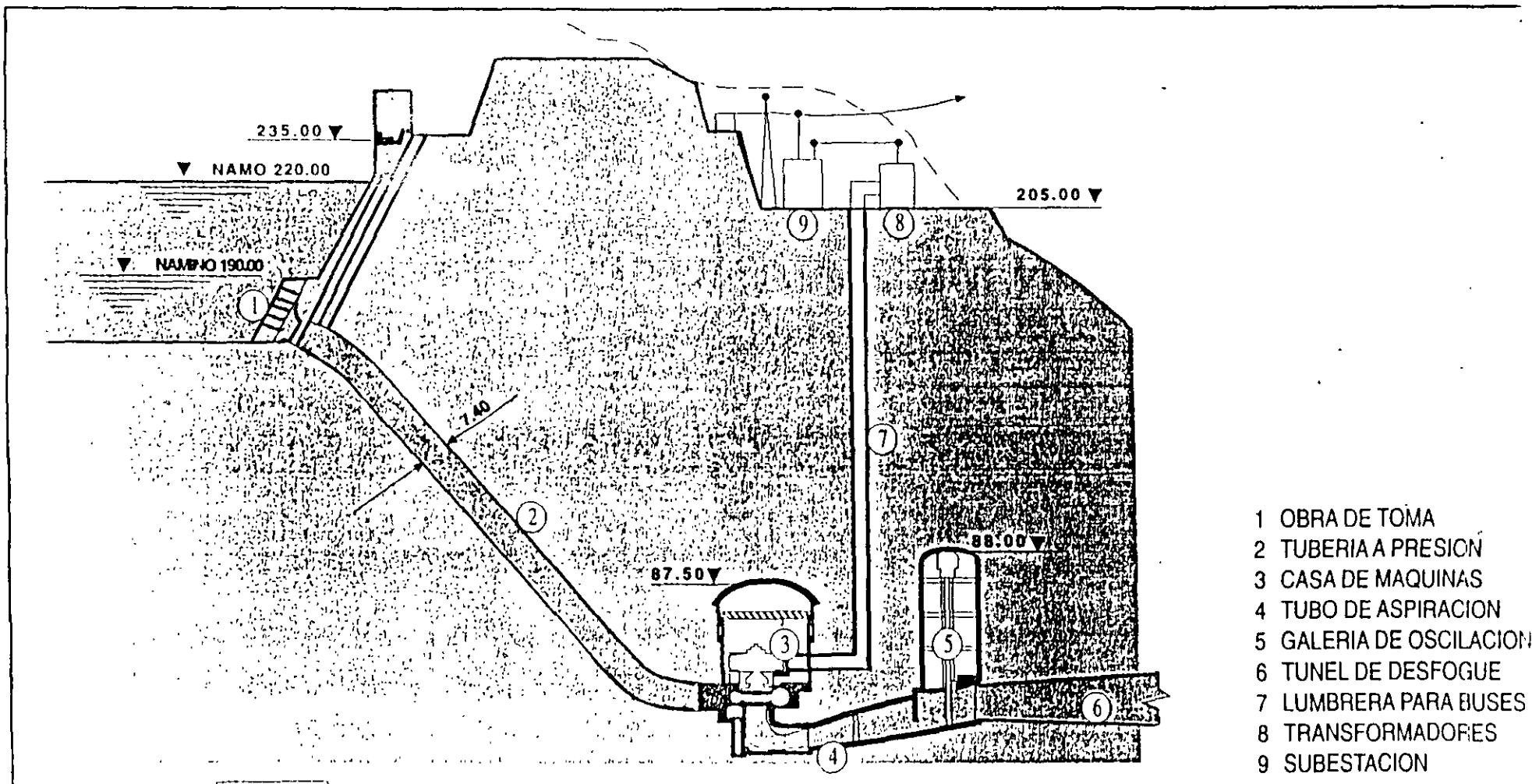

CENTRAL HIDROELECTRICA

AGUAMILPA

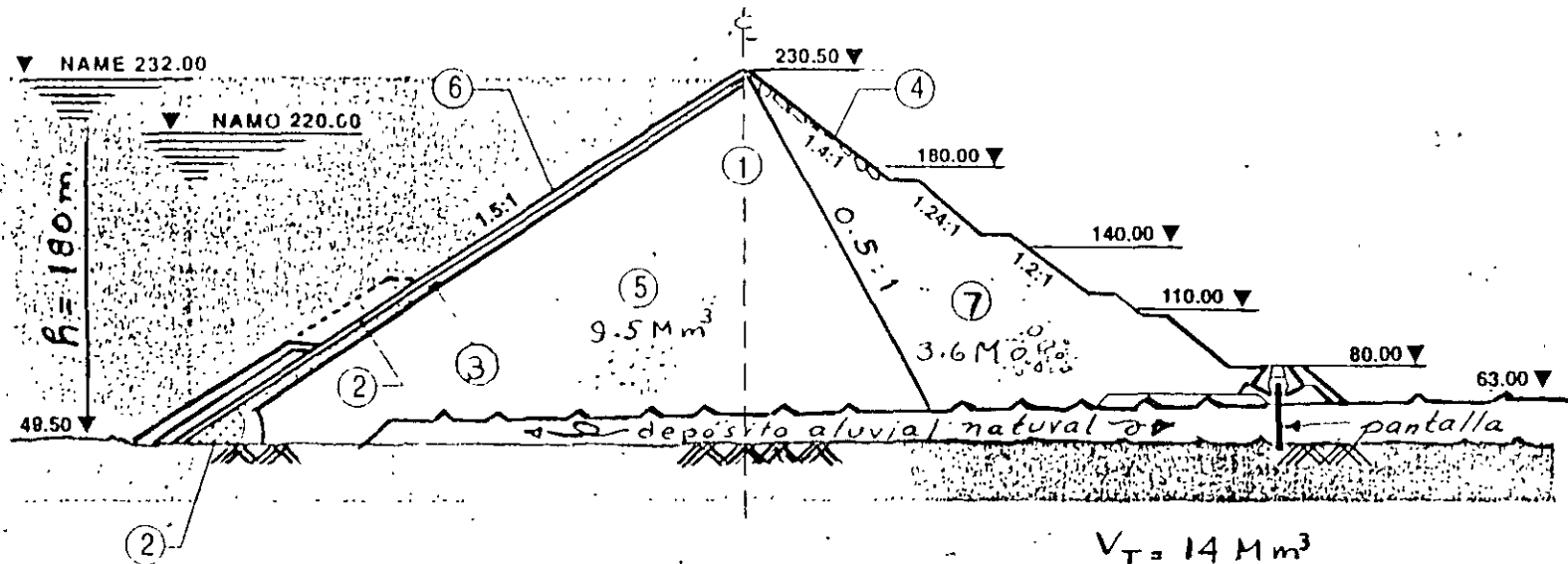

SECCION MAXIMA DE LA CORTINA

- | | |
|--------------------------------|---|
| 1 EJE CORTINA | 4 ENROCAMIENTO SELECTO $\phi > 1$ m. |
| 2 FILTRO (grava-arena y limo) | 5 ALUVION (hasta 8") |
| 3 TRANSICION (gravas hasta 3") | 6 CARA DE CONCRETO REFORZADO (de 30 a 80 cm.) |
| | 7 ROCA Y REZAGA (hasta $\phi < 1$ m.) |

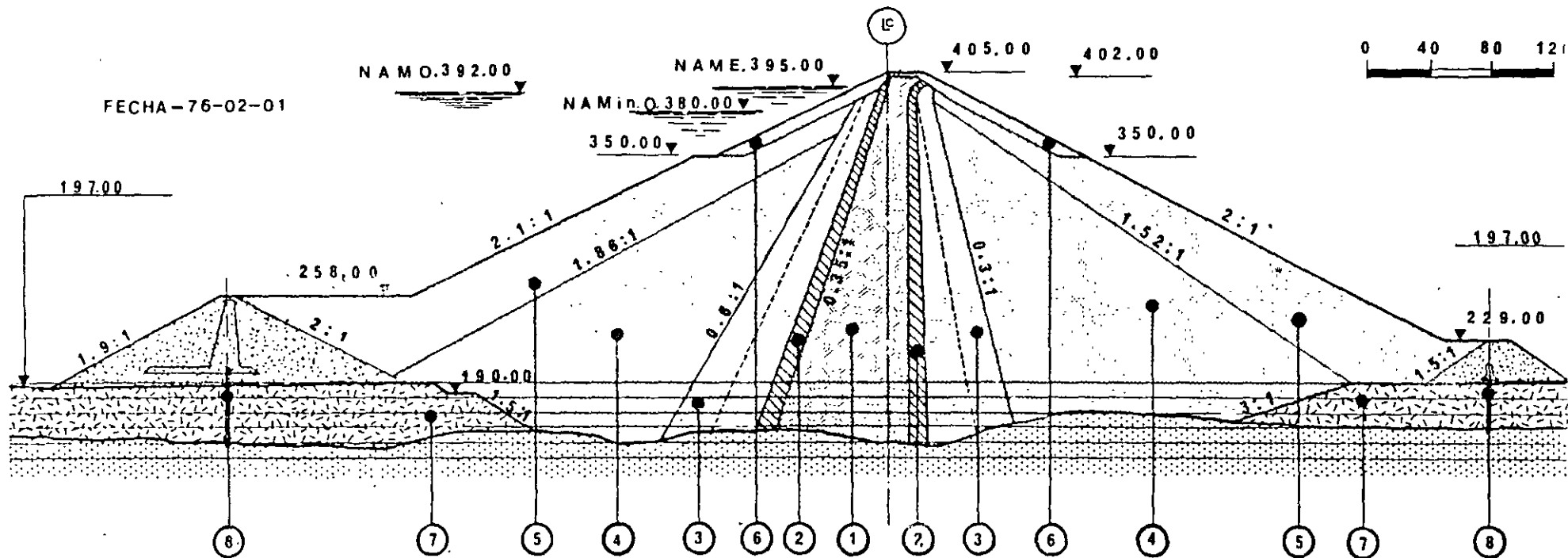

SECCION MAXIMA DE LA CORTINA

- | | |
|---------------------------|--------------------------------------|
| ① ARCILLA COMPACTADA | ⑤ ENROCAMIENTO ACOMODADO CON TRACTOR |
| ② FILTRO COMPACTADO | ⑥ ENROCAMIENTO DE GRAN TAMAÑO |
| ③ TRANSICION COMPACTADA | ⑦ ALUVION |
| ④ ENROCAMIENTO COMPACTADO | ⑧ PANTALLA IMPERMEABLE |

altura: 245 m.

VOLUMEN TOTAL

14.5 Mm³

Impermeable

2.1 " (14.5%)

CHICOASEN, CHIS

Construcción 1974/80

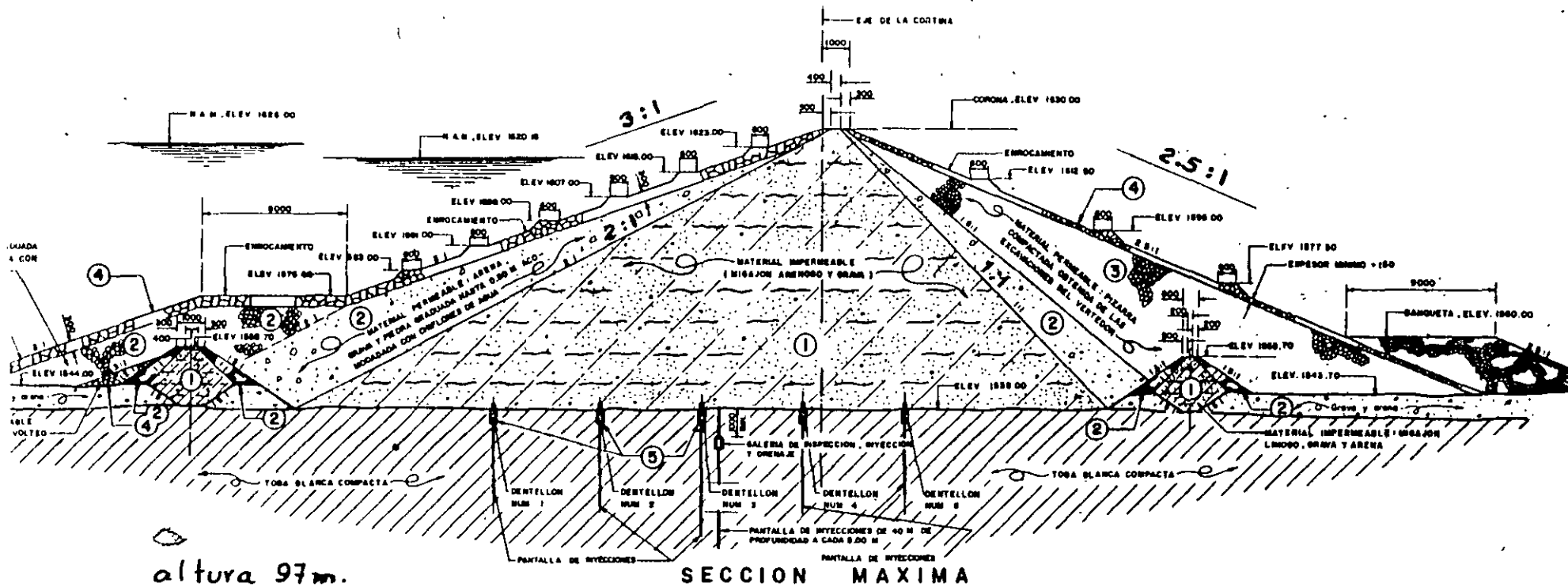

Construcción 1936/1946

SIGNOS CONVENCIONALES

- 1. — MATERIAL IMPERMEABLE
- 2. — MATERIAL PERMEABLE
- 3. — MATERIAL PERMEABLE (PIZARRA)
- 4. — ENROCAMIENTO
- 5. — DENTELLONES

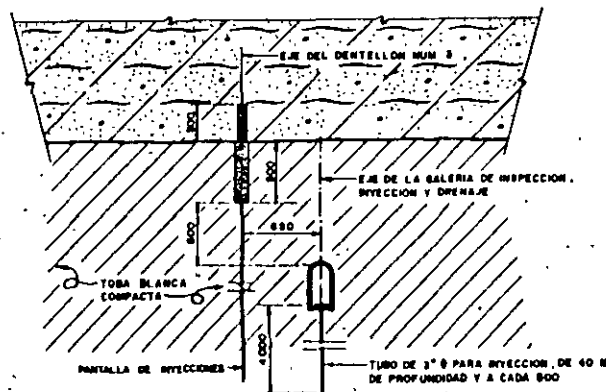

SECCION DE LA GALERIA Y DEL DENTELLON NUM. 3
EN EL LECHO DEL RIO

VOL TOTAL 5.3 Mm³
Impermeable 2.83 " (53.4%)

CORTINA

TRATAMIENTO DE LA CIMENTACION

PRESA "LAZARO CARDENAS", DGO. (EL PALMITO)

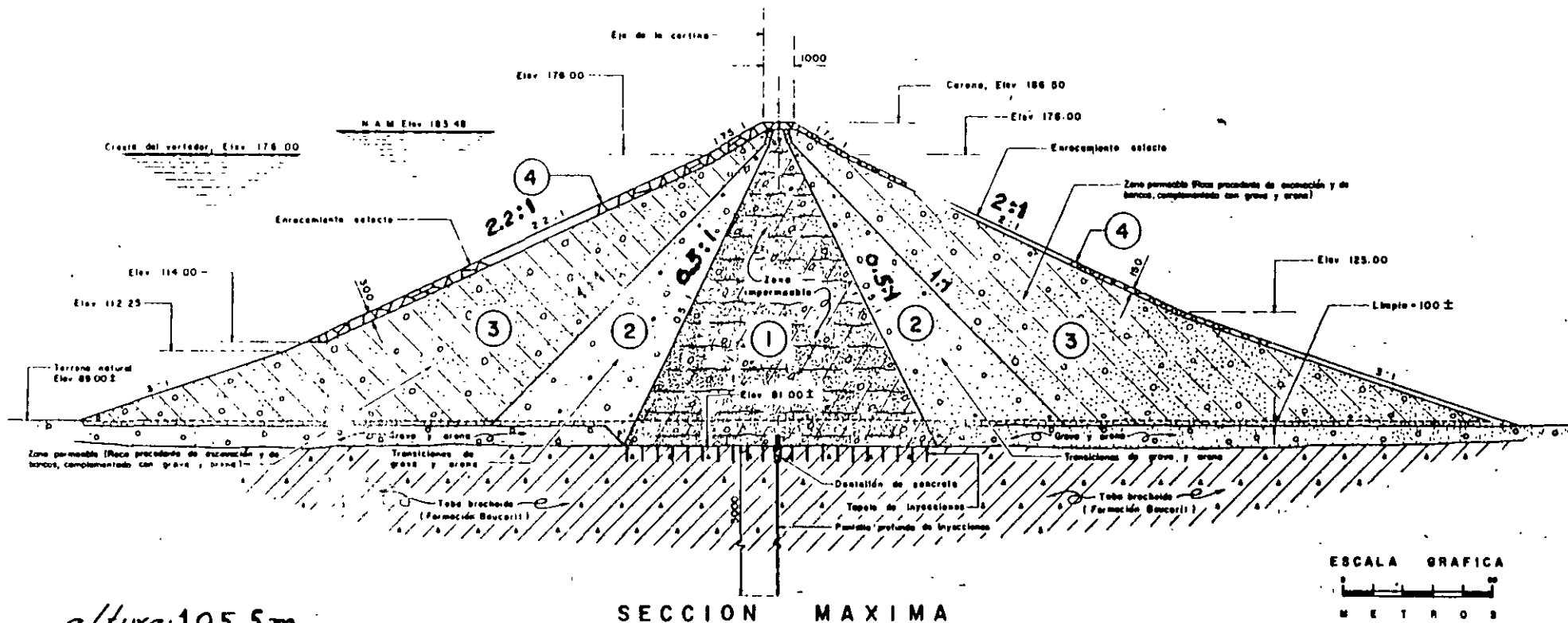

altura: 105.5 m.

SECCION MAXIMA

ESCALA GRAFICA
METROS

SIGNOS CONVENCIONALES

- 1. — MATERIAL IMPERMEABLE COMPACTADO
- 2. — TRANSICION DE GRAVA Y ARENA
- 3. — RESPALDOS PERMEABLES (ROCA, GRAVA Y ARENA)
- 4. — ENROCAMIENTO SELECTO

CORTINA

Construcción 1957/1964.

VOL CORTINA TOTAL 7.141 Mm^3
Impermeable 1.597 " (22.4%)

PRESA PRESIDENTE ADOLFO LOPEZ MATEOS, SIN. (EL HUMAYA)

12

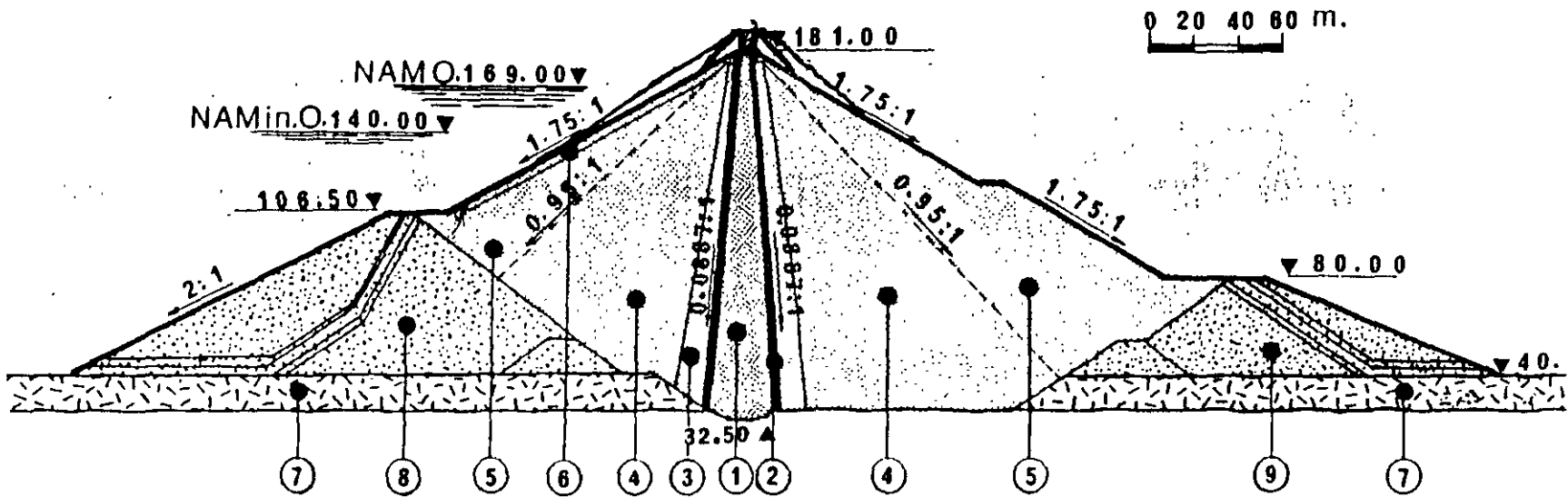

altura: 148.5 m.

sección máxima de la cortina

VOL TOTAL CORTINA 5.6 Mm³
 Impermeable 0.44 " (7.86%)

INFIERNILLO, MICH.
Construcción 1960/1964

12

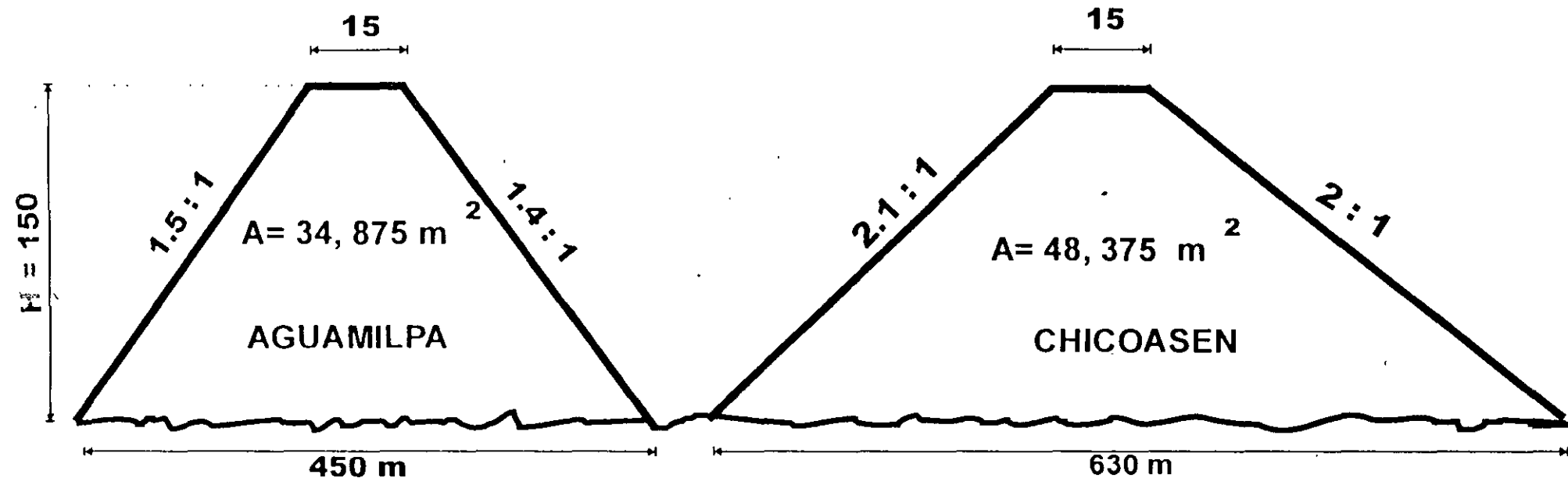

$$\frac{48,375}{34,875} = 1.3871$$

$$14 \times 1.3871 = 19.419 \text{ C}$$

AGUAMILPA con sección de materiales graduados hubiera sido de 19.5 Mm^3

$$\frac{34,875}{48,375} = 0.721$$

$$15 \times 0.721 = 10.814 \text{ Mm}^3$$

CHICOASEN con sección de enrocamiento y losa de concreto hubiera sido de 10.8 Mm^3

COMPARACIÓN DE VOLUMENES ENTRE UNA SECCIÓN DE ENROCAMIENTO Y UNA DE MATERIALES GRADUADOS.

CONTROL DURANTE LA CONSTRUCCIÓN DE LA OBRA.

PRUEBAS DE LABORATORIO DE CAMPO.

a) Terraplenes de prueba.

Objetivo: determinar la eficiencia del equipo.

Resultado: obtener el espesor de las capas y número de pasadas.

b) Determinación del peso volumétrico seco y humedad en el terraplén.

Prueba de compactación PROCTOR.

Objetivo: obtención del peso seco y humedad del terraplén mediante calas.

Resultado: obtener el porcentaje de los pesos secos y humedad. Debe ser mayor que el especificado (por ejemplo 95%) y la humedad la óptima.

c) Compactación y resistencia a la penetración.

Prueba rápida con un dinamómetro y agujas.

d) Densidad relativa de los materiales granulares.

$$D_r \% = \frac{e_{max} - e_t}{e_{max} - e_{min}} \times 100$$

e relación de vacío de los materiales

e) Pruebas de permeabilidad de campo (cualitativas).

Pozos de absorción.

Pozos de filtración (dos pozos contiguos).

Pozos radiales (por bombeo en el pozo central).

Referencia : MÉCANICA DE SUELOS.

Instructivo para ensaye de suelos SRH.

CONCLUSIONES

Una cortina es una estructura hiperestática que depende :

***De la deformabilidad de los materiales.
De la geometría de su sección zonada***

Es recomendable:

***Evitar la asimetría.
Cambios bruscos en la geometría.***

El ancho del corazón se debe elegir según:

***La carga hidrostática y tomar en cuenta la interacción
entre núcleo y cimentación.***

***Se recomiendan zonas amplias de filtros y
transiciones:***

COMENTARIO FINAL

El Dr. Terzaghi dice que la experiencia ha mostrado que la mayoría de las ramas de la ingeniería evolucionan recorriendo tres etapas sucesivas:

- *La empírica*
- *La científica*
- *La de madurez*

La empírica es a base de:

*Resultados a base a de tanteos
Intuición.*

La científica se basa en:

Razonamiento matemático.

Resultado de pruebas de laboratorio.

Relaciones fundamentales mínimas.

La etapa de madurez esta templada:

Por la experiencia

Lás restricciones impuesta por la naturaleza.

Los progresos se efectúan en forma semiempírica.

Los conocimientos se ponderan y se complementan con los análisis, y el buen juicio.

Así el rigor del análisis se reduce gradualmente del de un César al de un Comité Consultor.

CORTINAS DE ENROCAMIENTO CON LOSAS DE CONCRETO HIDRAULICO EN EL TALUD DE AGUAS ARRIBA

1. ANTECEDENTES.

Cortinas de Enrocamiento en México.

Desde el año de 1939, se definió una cortina de enrocamiento como (1):

" Una cortina consistente de enrocamiento suelto a volteo con pendientes en cada talud cercanas a la pendiente natural, con una placa o losa impermeable en el talud de aguas arriba, apoyada sobre una delgada zona de mampostería seca y posteriormente el enrocamiento propiamente dicho"

Este tipo de cortinas fueron construidas con cierta frecuencia desde fines del siglo pasado hasta los años de 1960 - 1965 pero, debido a los problemas de filtraciones que presentaban, y al advenimiento de las cortinas de materiales graduados, después de los años 40s., los ingenieros prefirieron estas últimas debido a su mejor comportamiento.

Sin embargo, el mejoramiento en los procedimientos de construcción y la observación en el comportamiento de las cortinas de enrocamiento en operación, permitieron ir obteniendo mejores resultados en dicho comportamiento, hasta llegar a la etapa moderna en donde se han obtenido características muy satisfactorias desde el punto de vista técnico y económico, que las hacen competitivas en comparación con los otros tipos de cortinas, aún cuando limitadas en la actualidad a alturas del orden de 160 m pero que se puede prever llegar a alturas mucho mayores en el futuro próximo. (2)

En México, en lo que va del siglo, se han construido cortinas de enrocamiento con losas de concreto en el talud de aguas arriba, y en la Tabla N° 1 aparecen las características de algunas de ellas.

Para una lista de las principales presas en el mundo, con cortinas de enrocamiento, puede consultarse la Tabla N° 2 del trabajo presentado por Cooke (2).

PRESAS CON CORTINA DE ENROCAMIENTO, EN MÉXICO.

Nombre	Localización	Año de Terminación	Altura m	Taludes (x)		Ancho de Corona, m	Losa de Concreto	
				A. Ar.	A. Ab		Arriba m	Abajo m
1. Taxhimay	Edo. de Hidalgo	1912 1934	43	0.75:1	1.4:1	4	0.20	0.40
2. Tacubaya	Distrito Federal	1938	26	1.4:1	1.4:1	5	—	—
3. Madero	Edo. de Hidalgo	1939	52	1.2:1	1.4:1	5	—	—
4. El Girón	Edo. de Hidalgo	1940	20	1.4:1	1.4:1	4	—	—
5. Mixcoac	Distrito Federal	1941	32	1.2:1	1.4:1	5	—	—
6. San Ildefonso	Edo. de Querétaro	1942	62	1.4:1	1.4:1	5	0.20	0.52
7. La Esperanza	Edo. de Hidalgo	1943	27	1.3:1 1.4:1	1.4:1	5	—	—
8. Colorines	Edo. de México	1944	32	1.4:1	1:1 1.3:1	6	—	—
9. Gonzalo N. Santos	Edo. de S.L.P.	1949	39	1.4:1	1.4:1	4.5	—	—
10. Ixtapantongo	Edo. de México	1950	28	1:1	1.5:1	3.5	—	—
11. Los Pinzales	Edo. de México	1957	59	1.2:1	1.4:1	5	—	—
12. Zicuirán	Edo. de México	1957	46	1.18:1 1.3:1 1.41:1	1.4:1	7	0.30	0.44
13. Texcalatlaco	Distrito Federal	---	---	---	---	---	---	---

(X) A. Ar = Aguas Arriba; A. Ab = Aguas Abajo.

FUENTE:

19

2

II. CARACTERÍSTICAS DEL ENROCAMIENTO COMPACTADO.

Como puede observarse en la Tabla N° 1, todas las presas con cortinas de enrocamiento construídas hasta la fecha en México, son de altura modesta y corresponden a las de enrocamiento a volteo, habiendo habido necesidad de hacerles reparaciones para disminuir las filtraciones que se presentaban.

Las cortinas a las que se referirán las notas siguientes, serán a las que -- Cooke nombra del período moderno, (2) de las cuales no existen ninguna -- construída en México, sino solamente están en estudio probablemente unas --
cinco tres: El Tunal II, en el estado de Durango; El Mezquite ^{Marquez} en el estado -- de Hidalgo, y Huites en el estado de Sinaloa, y *Aguamilpa en Nayarit y El Tule en Estado de México.*

Por consiguiente, las ideas que se expresarán a continuación, corresponden a las de diferentes ingenieros que han intervenido en el estudio, diseño y construcción de este tipo de cortinas, principalmente a las de Cooke, quien ha sido consultor en casi todas las construídas en los últimos 30 -- años (2).

Es indudable que solamente conociendo las características mecánicas de la roca de que se dispone, se pueden elaborar las especificaciones concretas para cada caso determinado; de manera que las ideas que se expresarán -- deberán considerarse de carácter general e ilustrativas.

Para que sirva como punto de referencia, se presenta la Figura N° 1 que corresponde a la sugerida por Cooke en su artículo:

" Progress in Rockfill Dam " (2), página 1412 para cortinas con alturas -- del orden de 245 m (800 piés) teniendo en cuenta el comportamiento de -- las presas construídas a la fecha.

II.1. Enrocamiento en el cuerpo de la cortina.

Una de las ideas que más ha contribuído al mejor comportamiento de las losas de concreto en el talud de aguas arriba, es la de corn

pactar el enrocamiento con 4 ó 6 pasadas de rodillo liso vibratorio de 10 Ton. de peso.

En la Figura Nº 1 el enrocamiento está mostrado como 4 y se anota el espesor máximo recomendable de las capas.

En la presa Foz Do Areia (3) la zona 4c se colocó en capas de 0.80 m de espesor, con resultados muy satisfactorios. La roca era basalto y brecha basáltica.

II.2. Uso de gravas en cortinas de enrocamiento.

Aún cuando las gravas caen fuera de la definición de enrocamiento, pueden usarse como material para los respaldos de la cortina, ya sea en combinación con enrocamiento o solamente gravas. El módulo de compresibilidad es 5 a 10 veces mayor que el del enrocamiento compactado y del orden de 40 veces el del enrocamiento a volteo (2).

Por consiguiente, la grava es un material que puede usarse con ventaja en cortinas de enrocamiento, y es posible construir las de alturas mayores que con roca solamente.

II.3. Uso del agua en enrocamiento compactado.

El uso de agua a presión en enrocamientos compactados, depende mucho de la calidad de la roca. En el caso de roca dura y sana, es ya común el usar entre 25% y 50% de agua en volumen, con respecto al volumen de roca.

En el caso de gravas, usualmente no se añade agua.

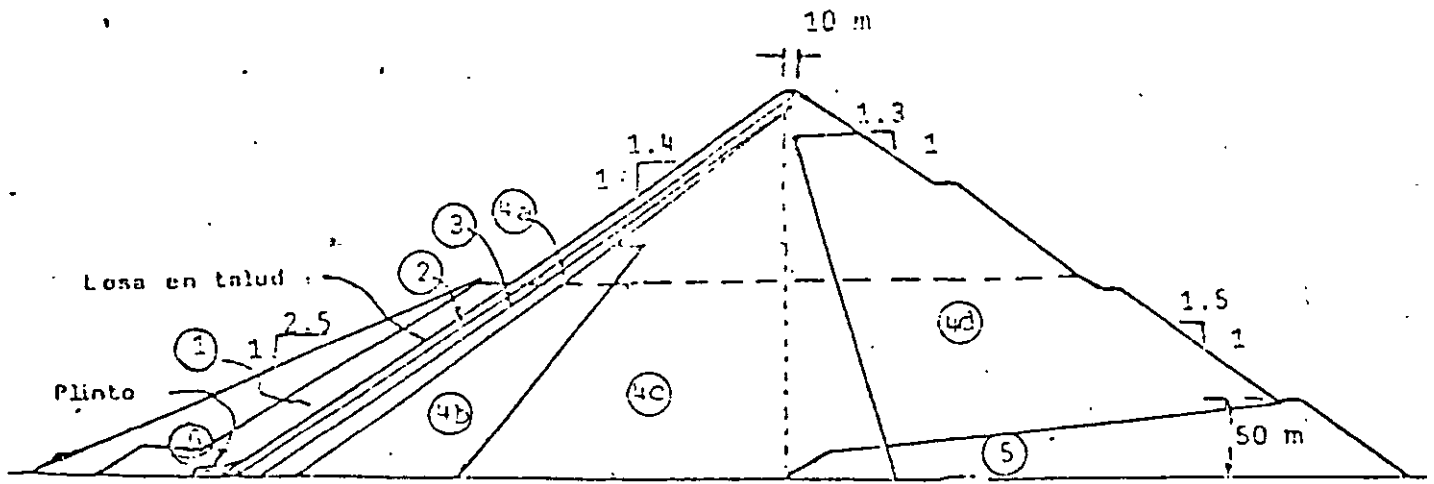

SECCION MAXIMA

- 1 Impermeable
- 2 Filtro; capas de 0.40 m.
- 3 Grava menor de 7.5 cm (3") capas de 0.40 - 0.50 m
- 4 Enrocamiento compactado
 - 4a Capas de 0.50 m.
 - 4b Capas de 0.60 m.
 - 4c Capas de 1.50 m. (Es conveniente que esta zona se contruya con capas del orden de 1.0 m.). +
 - 4d Capas de 1.8 m.
- 5 Enrocamiento a volteo, (solamente en el lecho del río)
- 6 Enrocamiento acomodado



FIGURA Nº 1

Sección conceptual de una cortina de enrocamiento con 245 m de altura con losas de concreto aguas arriba: (7).

(Debe entenderse que la distribución del enrocamiento en las zonas 4b 4c 4d y 5 se hará en cada caso particular de acuerdo con la disponibilidad y calidad de la roca o grava).

+ Nota de Francisco Torres Herrera.

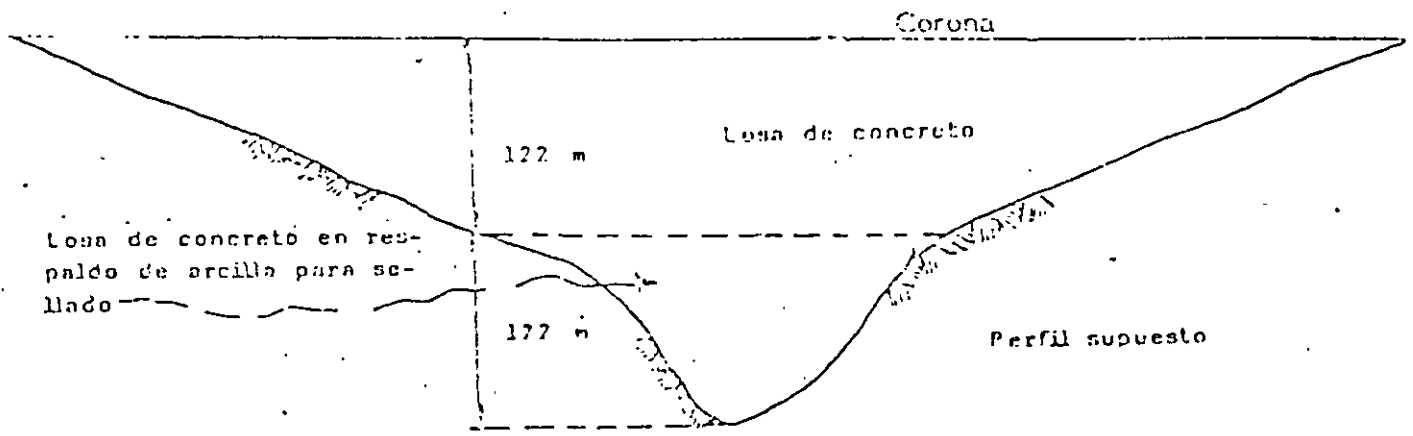
III. ENROCAMIENTO EN EL TALUD DE AGUAS ARRIBA. Zona 2

Esta zona 2 tiene por objeto soportar directamente la losa de concreto y, de acuerdo con la práctica actual, se busca que el material que la forma, cumpla con una granulometría especificada general como se muestra en la tabla siguiente: (4).

T a m a ñ o	Por ciento más fino
7.5 cm (3")	90 - 100
3.8 cm (1½")	70 - 95
1.9 cm (¾")	55 - 80
Malla Nº 4	35 - 55
Malla Nº 30	8 - 30

Este material puede obtenerse con roca triturada o grava aluvial, y con la clasificación recomendada se consigue:

- 1). Que tenga un coeficiente de permeabilidad del orden de 10^{-3} ó 10^{-4} cm/seg eliminando así la posibilidad de grandes valores de filtración en caso de agrietamiento de la losa o abertura de las juntas.
- 2). Evitar la segregación del material y por consiguiente, mejorando la trabajabilidad del mismo, y eliminando la posibilidad de desperdicio de concreto en la losa.

Esta zona 2 puede ser paralela a la losa de concreto con un ancho en sentido horizontal del orden de 5.0 m.

Debe dársele 4 ó 6 pasadas con rodillo liso vibratorio con peso de 10 Ton. en capas de 0.40 - 0.50 m y posteriormente, 4 ó 6 pasadas con rodillo liso, en la superficie inclinada en el sentido del talud. Una vez termi-

nada la superficie, no se debe permitir relleno alguno. Con objeto de evitar la erosión de la superficie de contacto con la losa de concreto, es conveniente darle un baño de emulsión asfáltica o gunita. *o concreto lijado.*

Las zonas 3 y 4a funcionan como graduación entre las zonas 2 y el enrocamiento de las zonas 4b y 4c. Su espesor puede ser variable.

El enrocamiento puede desplantarse sobre los acarrees del río, cuando su calidad resulte adecuada, a partir de las pruebas de compactación correspondientes.

IV. LOSAS DE CONCRETO EN EL TALUD DE AGUAS ARRIBA.

La distribución del enrocamiento en el cuerpo de la cortina, su graduación y el procedimiento de colocación tuvieron como objeto disminuir las deformaciones que pudieran tener influencia sobre la losa de concreto en el talud de aguas arriba, incluso en el caso del empuje hidrostático total.

Las observaciones hechas en las presas de Cethana, Mackintosh y Murchison (5) indicaron que la losa de aguas arriba experimentó una compresión biaxial con los valores máximos cerca de la vertical al centro de la losa. Zonas de tensión se presentaron cerca del talón, la corona y cerca de los reentrantes en el perímetro de la cimentación.

Los movimientos de las juntas se presentaron en tres direcciones: dos en el plano de la junta y uno normal a la superficie; pero todos ellos en la junta perimetral, ya fuera en el talón, en las zonas reentrantes o cerca de la corona.

Los resultados anteriores confirmaron la conveniencia de eliminar las juntas de contracción - dilatación en el sentido horizontal y construir juntas verticales con objeto de utilizar cimbras deslizantes en el proceso de colado. También es necesario construir una junta perimetral, en el arran

Elementos de diseño en la presa Salvajina.

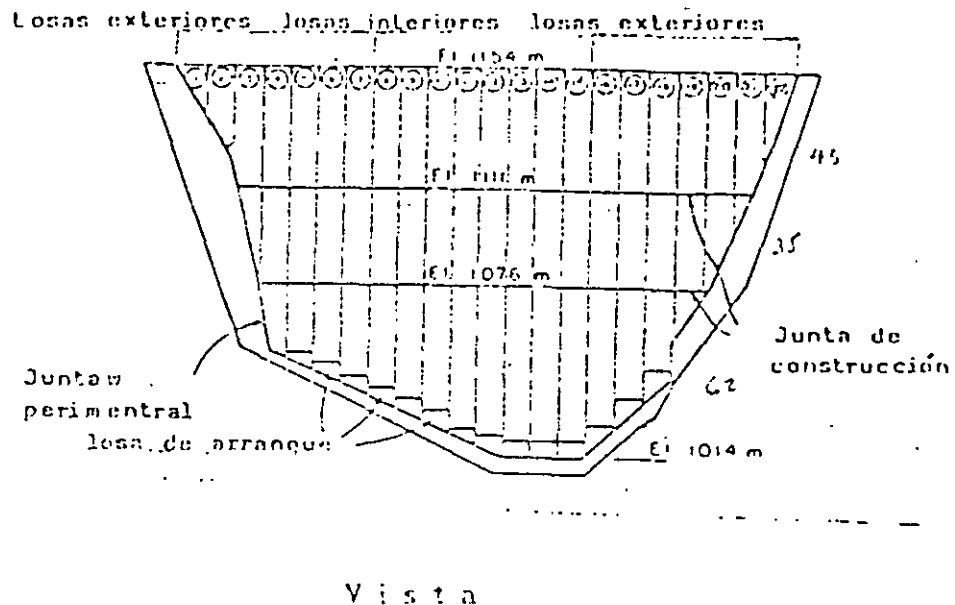

Fig. 2 Losas en talud de agua arriba.

En la Figura Nº 2 se muestra un corte en la boquilla y la distribución de las losas en la cara de aguas arriba, así como las juntas, tanto de construcción como de contracción - dilatación.

El ancho de las losas es de 15.0 m y se aprecia la distinción entre las losas centrales, en donde se presentaron compresiones, y las exteriores en donde se esperan tensiones. Una consideración semejante se hizo en la presa Foz De Arcia. (3).

IV.1. Plinto.

Ya se ha generalizado el nombre de Plinto para designar la losa de talón, razón por la que así se utilizará en estas notas.

Dentro de la evolución que ha sufrido el diseño y construcción de cortinas de enrocamiento, uno de los elementos sobresalientes ha sido la eliminación del dentellón en el arranque de las losas del paramento mojado, y sustituirlo por una losa o Plinto, de concreto reforzado desarrollada sobre la roca de cimentación. Se reco

mienda que tenga un ancho de 6 a 8 m ó variado entre $\frac{H}{10}$ a $\frac{H}{20}$, siendo H la carga hidrostática, en cada punto, según la calidad de la cimentación. El espesor puede tener un valor mínimo de --- 0.60 m.

Es conveniente que el Plinto sea anclado a la cimentación, con -- objeto de que sirva de apoyo a las actividades de consolidación é inyectado. El tipo y espaciamento de las anclas estará de --- acuerdo con la calidad de la roca de cimentación.

En caso de que en la roca de cimentación existan materiales ero-- sionables, es posible prolongar el Plinto como losa dentro del cuer-- po de la cortina, con objeto de disminuir el gradiente en esa zona (9). Figura Nº 3.

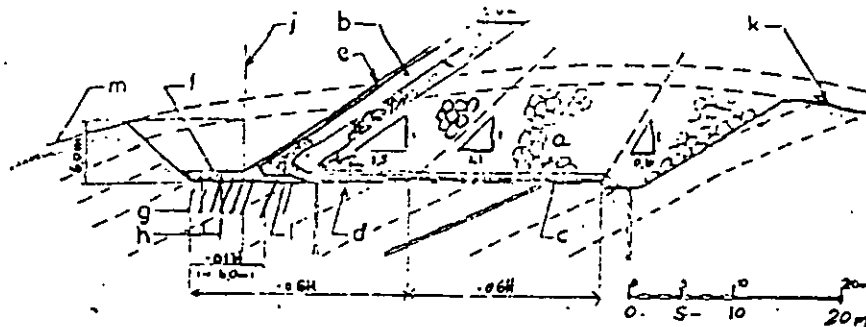

Fig. 3. Detalles de la cimentación de la Presa Winneke.

- | | |
|----------------------------|---|
| a) Enrocamiento | 3) Línea de referencia del Plinto |
| b) Zonas de transición | 4) Roca estratificada muy alterada. |
| c) Filtros | 5) Refuerzos |
| d) Concreto en cimentación | 6) Superficie original del suelo |
| e) Losa de concreto | 7) Carga hidrostática a la elevación de la cimentación. |
| f) Plinto | |
| g) Barras de anclaje | |
| h) Pantalla de inyectado | |

IV.2. Juntas de contracción - dilatación.

En las Figuras 4, 5 y 6 aparecen detalles de las diferentes juntas utilizadas en la cortina de la presa Salvañina, y en (3), (5) y (7) se pueden observar soluciones semejantes en otras presas modernas.

IV.3. Junta perimetral.

Estas juntas son las que presentan posibilidades de movimientos, - tanto en el plano de la junta como normalmente a ella, y además, tendencia a la abertura debida a fuerzas de tensión. Es por lo tanto conveniente hacer un diseño cuidadoso de ellas con dos o -- más líneas de defensa contra la filtración. Véanse las figuras y artículos citados en el punto anterior.

Elementos de diseño en la presa
Salvajina

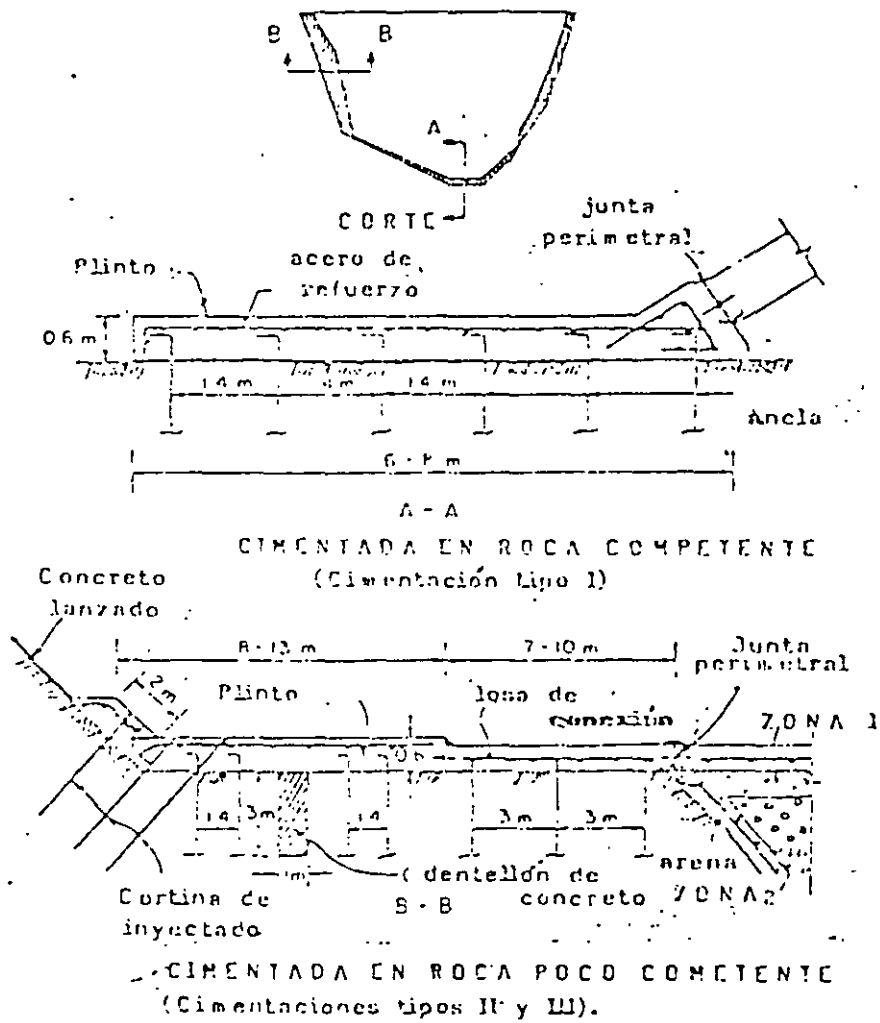
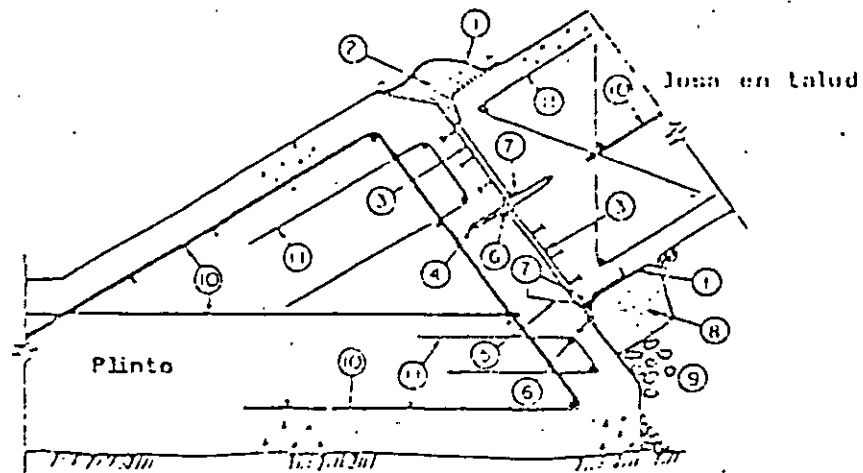
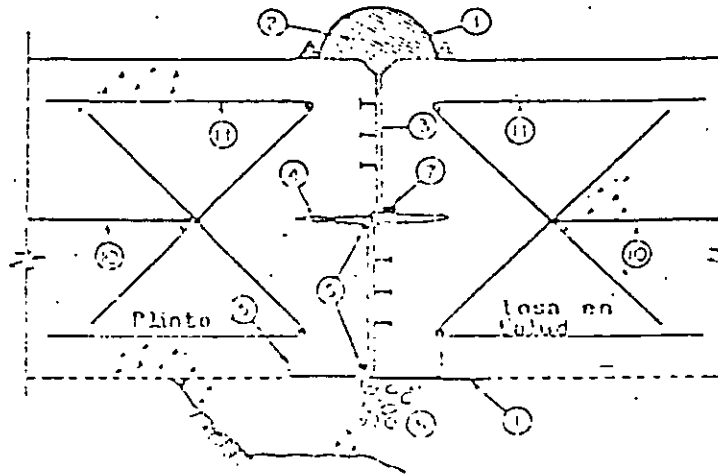

FIG. 4 PLINTOS CIMENTADO EN ROCA

ELEMENTOS DE DISEÑO DE LA PRESA SALVAJINA



A - En el fondo del río



B - En arranque de taludes.

- | | | | |
|---|---------------------------|---------|---|
| 1 | Banda de P V C | 9 | Zona I |
| 2 | Relleno de plástico | 10 y 11 | Refuerzo de acero para proteger el concreto contra fracturamiento y la tapajunta. |
| 3 | Relleno compresible | | |
| 4 | Tapajunta de polivinilo | | |
| 5 | Tapajunta de cobre | | |
| 6 | Tira de neoprene | | |
| 7 | Relleno de Styrofoam | | |
| 8 | Mezcla de arena - asfalto | | |

FIG. 5 DETALLES DE JUNTA PERIMETRAL

ELEMENTOS DE DISEÑO DE LA
PRESA SALVAJINA

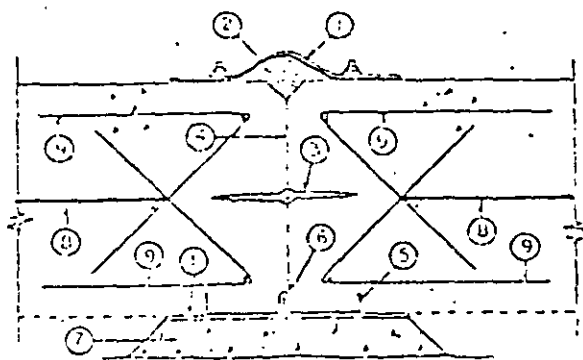

A - LOSAS EXTERIORES

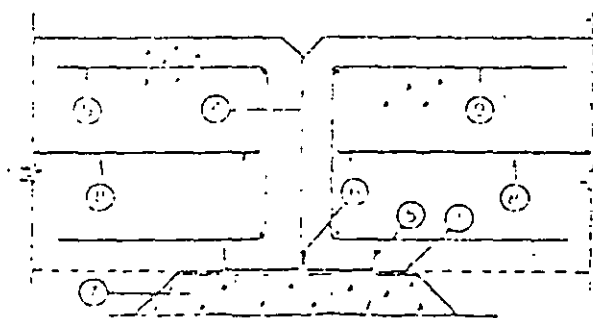

B - LOSAS INTERIORES.

- | | |
|---|---|
| 1. Banda de cloruro de polivinilo | 7. Base de mortero |
| 2. Relleno plástico | 8. Refuerzo principal de acero. |
| 3. Tapajunta de p v c | 9. Refuerzo de acero para proteger el concreto contra fracturamiento y tapajunta. |
| 4. Superficie cubierta con pintura asfáltica. | |
| 5. Tapajunta de cobre | |
| 6. Relleno de neoprene | |

FIG. 6 JUNTAS EN LAS LOSAS DEL TALUD

I.V. Muros en parapeto.

Con objeto de reducir el volumen de enrocamiento, ya es común que todas las cortinas modernas tengan un muro de contención en forma de L en la parte superior del talud de aguas arriba, como se muestra en la Figura Nº 7.

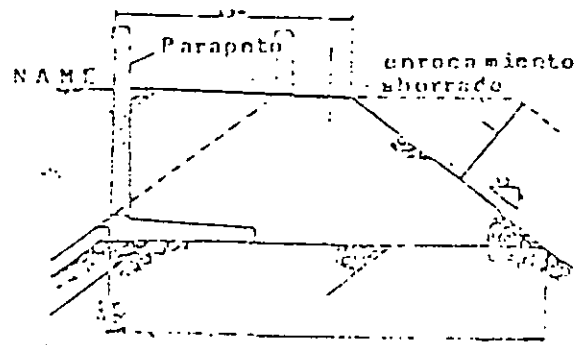

7 m ancho de corona temporal durante la construcción de las lomas de talud.

sección en la corona

FIG. 7 Muros en parapeto. (5).

La altura del muro puede ser de 4-5 m arriba de la cresta temporal; pero las dimensiones en cada caso particular dependerán del ancho de corona de diseño. Véanse (3), (5), (7) y (8).

En Salvajina, el muro tiene una altura de 8.0 m y ancho de corona de 8.0 m (6).

En la presa de Yacambu (8), se colocó un muro de contención - también en el talud de aguas abajo, con objeto de aumentar el ancho de la corona.

V. CIMENTACION.

Es frecuente argumentar que la construcción de una cortina tipo de enrocamiento con losas de concreto en el talud de aguas arriba, debe condicionarse a los casos en que se tiene una roca de cimentación de buena calidad, inyectable y no erosionable (2).

Sin embargo, ya en la actualidad se han construido cortinas de enrocamiento en cimentaciones de roca alterada y con fracturas rellenas de material erosionable, como lo anota Ranji Casinader para el caso de la presa Winneke en Australia. (9). en donde establece:

- " La losa de talón convencional, con longitud de $0.1 H$ de agua en cualquier punto, fué prolongada hacia aguas abajo como una losa de concreto de 150 mm de espesor mínimo, de tal manera que el ancho total de la losa de talón y Cimentación de concreto fué de 0.5 de la carga de agua en cualquier punto ".
- " La cimentación aguas abajo de la Cimentación de concreto, fué protegida por filtros invertidos, en una distancia equivalente a 0.5 de la carga de agua ".
- " Se adoptó una pantalla de inyectado con dos líneas de perforaciones, las cuales fueron lavadas con aire y agua antes de inyectar con mezclas de cemento sólo ". (Véase figura 3).

Por otra parte A.H. Merritt (10) anota que en una presa reciente la experiencia mostró que la losa de talón, Plinto, puede localizarse a una profundidad en donde la roca tenga una recuperación de 75% y un R.Q.D. con valores mayores a 50 - 60 %.

También establece que para la construcción del Plinto y el inyectado pueden adoptarse varias medidas sin interferir con las otras presas.

De manera que es previsible para el futuro, poder resolver problemas de cimentaciones en rocas de no muy buena calidad, tomando las medidas adecuadas.

También la cortina de la presa Salvajina se desplantó en cimentación heterogénea con zonas alteradas (6).

VI. INSTRUMENTACION Y COMPORTAMIENTO.

Desde la construcción de las presas Wilmot y Cethana en Australia por los años 1969 - 1970, las cuales fueron ampliamente instrumentadas, se han ido desarrollando nuevas ideas sobre el diseño y construcción de cortinas de enrocamiento con losas de concreto en el talud de aguas arriba, basadas principalmente en la observación del comportamiento de las mismas, durante la construcción, el llenado y la operación.

Aún cuando en la actualidad existe una gran cantidad de datos de presas construídas en el mundo, es conveniente que las presas mexicanas que se construyan con las nuevas ideas, sean dotadas de la instrumentación adecuada para comprobar su comportamiento, e ir adquiriendo experiencia propia en dicho campo.

Las cortinas de enrocamiento con losas de concreto en el talud de aguas arriba, han mostrado que son estructuras estables y seguras para condiciones estáticas y dinámicas, y es probable que en México, en el futuro, se construyan presas con cortinas de enrocamiento de alturas de cierta consideración, incluso en zonas de gran sismicidad. Es por consiguiente deseable dotar a dichas cortinas de instrumentación para medir deformaciones, movimientos y variaciones de temperatura en el concreto, que se presenten durante su vida.

VII. MANEJO DEL RIO DURANTE LA CONSTRUCCION.

Una de las ventajas de las cortinas de enrocamiento es la que, en determinadas condiciones, se puede permitir que el agua de una avenida, pase por encima del enrocamiento.

Se puede prever la construcción de las obras de un desvío para una presa, con una pequeña ataguía fuera del cuerpo de la cortina, para un determinado tiempo de recurrencia y construir una primera etapa de la cortina.

Si se preve la presencia de una avenida de mayor tamaño, durante la --

etapa de construcción, es posible tomar las precauciones necesarias para que el agua pase sobre el enrocamiento, sin degradarlo.

Para este caso, debe procederse a reforzar con varilla de acero, el talud de aguas abajo.

En estas condiciones el esquema para las obras de desvío, puede diseñarse para una avenida pequeña, con una economía de consideración.

México, fué de los primeros países del mundo en donde se usaron protecciones para casos de flujos de agua sobre el enrocamiento. (11).

El primero de ellos fué en la presa San Ildefonso, en el estado de Querétaro en el año de 1939 y otro en la presa Tacotán en Jalisco, ambas -- atribuidas al Ingeniero A. Weiss.

En el Boletín 48 de ICOLD. (11) de 1984, se alude a 54 casos en el mundo en donde se protegieron los enrocamientos, 22 de los cuales sufrieron flujos encima de ellos.

En esta misma publicación se muestran los métodos usados y los resultados obtenidos.

Alan Varty, Rick J. Boyle, Edward D. Pritchard y Roger E. Gill, -- (12) anotan algunas experiencias obtenidas en Australia e indican que -- " Si se construyen adecuadas protecciones sobre las cortinas de enrocamiento, dichas presas son seguras contra desbordamiento; antes y durante la construcción de la losa de concreto ".

En la publicación Concrete Face Rockfill Dams - Design, Construction and Performance.- Proceedings of a Symposium of the Geotechnical -- Engineering Division of ASCE Oct/1985 (14) aparecen algunos otros -- casos de presas modernas cuyas cortinas han sido protegidas aguas abajo para caso de flujo de aguas sobre ellas.

VIII. VERTEDOR DE EXCEDENCIAS SOBRE LA CORTINA.

Una de las ideas aceptadas actualmente, es la de que no se deben --- construir vertedores de excedencias sobre el cuerpo de una cortina de enrocamiento, debido a los asentamientos tan grandes que experimen-- tan tales estructuras. Sin embargo, las cortinas de enrocamiento --- construídas con los procedimientos modernos sufren asentamientos, --- principalmente durante la construcción, de manera que sería convenien- te ir pensando en diseñar los vertedores en el cuerpo de las cortinas, aún cuando fuera en algunas de pequeña altura, para ir observando su comportamiento.

James L. Sherard (13) hace una defensa de esta idea, y anota que se han elaborado algunos proyectos de presas con tal solución, pero -- que se han abandonado por falta de antecedentes, lo cual es lamenta- ble.

IX. RESUMEN Y CONCLUSIONES.

En vista de que a la fecha no existe en México experiencia con tecno- logía moderna en el diseño y construcción de cortinas de enrocamiento con losas de concreto en el talud de aguas arriba, las futuras cortinas que se construyan deberán basarse, al principio, en tecnología extranje- ra. Las especificaciones constructivas se elaborarán con claridad y - concisión y el control de calidad durante la construcción deberá ser es- tricto y hecho por personal calificado.

Por consiguiente, puede establecerse lo siguiente:

- a) Debe terminarse la construcción de la totalidad de los enrocamien- tos, antes de iniciar la construcción de las losas de concreto. - Esto trae consigo el uso de cimbras deslizantes.
- b) El enrocamiento deberá construirse con roca de calidad conocida,

bien graduada y compactada en capas con espesor máximo de --- 1.50 m en la parte de aguas abajo del cuerpo principal, adicionando entre 15% y 50% de agua a presión.

La compactación se hará con rodillo liso vibratorio de 10 Ton. de peso, con un número mínimo de pasadas de 4. Cuando sea posible, la compactación se hará en líneas paralelas y normales al eje de la cortina.

En una zona cercana al talud de aguas arriba, deberá dársele un tratamiento especial:

1. La graduación del material debe ser controlada.
2. Dar con cuidado la línea de proyecto del talud.

Debido a que la compactación no puede hacerse hasta la orilla, -- es conveniente dar compactación en el sentido del talud para evitar asentamientos indeseables. Esta compactación puede hacerse con 4 pasadas de rodillo vibratorio de 10 Ton. de peso.

Una vez terminada la compactación del talud, debe tratarse la superficie para evitar la erosión por condiciones del clima o por los trabajadores.

Como ya quedó establecido, este tratamiento puede hacerse con emulsión asfáltica o con gunita.

Debe aclararse que, en el caso de la presa Cethana se hizo un -- bordo de prueba para afinar los procedimientos de acuerdo con los materiales disponibles.

- c) Todas las juntas verticales en las losas deberán ser a tope, sin --- ningún tipo de material blando de relleno.

Las juntas horizontales serán exclusivamente de construcción.

- d) Deberá tenerse un cuidado especial en el diseño y construcción de

las juntas perimetrales, a las cuales se les dotará de varias líneas de defensa contra la filtración. Así como, se reforzará el concreto en la zona de estas juntas para prevenir la ruptura del concreto y proteger la tapajunta de cloruro de polivinilo.

- e) Es conveniente reducir al máximo el espesor de las losas de concreto, debido a que las deformaciones son independientes del espesor de las mismas, y sí lo son de la calidad del enrocamiento.
- f) En el arranque de las losas de concreto se construirá un Plinto en lugar del dentellón tradicional. En esta zona se podrá dar tratamiento a la cimentación, de acuerdo con las condiciones particulares de la misma.
- g) Previendo la necesidad de vaciar el vaso de la presa en caso de requerirse inspecciones y reparaciones, es conveniente contar con descargas de fondo con capacidad adecuada.
- h) En caso necesario, en el que se prevea un desbordamiento, es conveniente armar el enrocamiento en el talud de aguas abajo.
- i) Es recomendable que las futuras cortinas de enrocamiento cuenten con instrumentación adecuada que permita observar su comportamiento, e ir adquiriendo experiencia propia en México.

México, D.F., Agosto de 1986

CONSULTIVO TECNICO

Ing. Francisco Torres Herrera
Ingeniero Consultor

REFERENCIAS.

1. Galloway, J.D. " Symposium the design of Rockfill Dams " -----
Transactions, ASCE, Vol. 104, 1939, Pags. 1 - 92. U.S.A.
2. Cooke, J.B. " Progress in Rockfill Dams " Journal of the -----
Geotechnical Engineering Division, ASCE, october 1984. Pags. 1381-
1414. U.S.A.
3. Pinto, N.L. de S., Materson B., Lagos Marques Filho P. Design -
and Performance of Foz Do Areia concrete membrane as Related to -
Basalt properties.
XIV Congreso de Grandes Presas, Río de Janeiro, 1982. Q.55, R51,
Pags. 873 - 906. Brasil.
4. Sherard J.L. The Upstream Zone in Concrete - Face Rockfill Dams.
ASCE Convention in Detroit, Michigan, october 1985.
5. Fitzpatrick Mike D., Cole Bruce A., Kinstler Frank, L., y Koop
Bramp. Design of Concrete - Face Rockfill Dams. ASCE. -----
Convention in Detroit, Michigan, october 1985. Australia.
6. Sierra, Jesús M., Ramírez Carlos A. y Hacelas Jorge E., -----
Design Features of Salvajina Dam.
ASCE Convention in Detroit, Michigan, october 1985.
7. Pinkerton Iver L., Siswamidjono Soetomo, and Matzui Yutaca. ----
Design of Cirata Concrete Face Rockfill Dam.
Concrete Face Rockfill Dams.
Symposium. ASCE in Detroit, Michigan, U.S.A. october 1985.
8. Martínez José M. Ortega, Carrero Luis.
Design of Yacambu Dam. XIV Congreso de Grandes Presas. ----
Río de Janeiro, 1982
9. Ranji Casinader, Discussion sobre Progress in Rockfill Dams. Journal
of Geotechnical Engineering, Division, Vol. 112, Nº 2. Feb. 1986,
Pag. 217. U.S.A.

10. Merrit A.H., Discussion of Progress in Rockfill Dams. Journal of - Geotechnical Engineering, Vol. 112, No 2. Feb. 1986. Pag. 229.
11. Maitrise de la Riviere Pendant la Construction du Barrage. Commission Internationale des Grands Barrages. Bulletin 48 - 1984.
12. Alan Varty, Rick J. Boyle, Edward D. Pritchard y Roger E. Gill. Construction of Concrete Face Rockfill Dams. Symposium Geotechnical Engineering Division, ASCE. Oct. 1985.
13. Sherard James L. Discussion Progress in Rockfill Dams. Journal of - Geotechnical Engineering Division Vol. 112, No 2. Feb. 1986. --- Pag. 247. U.S.A.
14. Symposium of the Geotechnical Engineering Division ASCE. Concrete Face Rockfill Dams. Design, Construction and Performance. ---- Oct. 1985. U.S.A.

FACULTAD DE INGENIERIA DE LA UNAM
DIVISION DE EDUCACION CONTINUA

PRESAS DE ALMACENAMIENTO
CURSO BREVE PARA RESIDENTES DE CONSTRUCCION

TEMA

V PRESAS DE TIERRA Y ENROCAMIENTO

Expositor: Ing. Joel Rojas Tamez
Lugar: Escuela de Minería Tacuba 5
Fecha: Junio 26, 99
Hora: 14:30 a 16:00

INGENIERIA GEOLOGICA Y LAS OBRAS HIDRAULICAS

I).- DESPLANTE DE PRESAS.

I N D I C E

- 1.- INTRODUCCION.
- 2.- EXCAVACION DE LA CIMENTACION.
- 3.- CONSTRUCCION DE PRESAS EN DEPOSITOS NO CONSOLIDADOS.
- 4.- OPERACIONES DE INYECTADO EN LA ROCA.
- 5.- INTERVALOS DE INYECCION CON OBTURADORES.
- 6.- PLANTILLA DE INYECCIONES.-
- 7.- INYECCIONES EN TAPETE.
- 8.- INYECCIONES DE PANTALLA.
- 9.- EJEMPLOS DE PANTALLAS DE INYECCION.
- 10- INYECCIONES EXTRAS PARA PROPOSITOS ESPECIALES.
- 11- CONSISTENCIA Y PRESION DE LA LECHADA.
- 12- PERFORACIONES DE DRENAJE Y OBSERVACION, POZOS Y PRISMAS POROSOS.
- 13- REFORZAMIENTO DE LA ROCA POR ANCLAS Y CABLES.
- 14- ESTABILIZACION DE LOS TALUDES DEL VASO.
- 15- INFORME FINAL DE CONSTRUCCION.

- - -

La primera presa construída al principio por el hombre, fué un terraplén bajo o estructura de roca destinada para embalsar y derivar el agua para usos agrícolas.

Hoy la superficie de la tierra está llena de pequeñas y grandes presas y almacenamientos, contribuyendo en una gran variedad de modos a los requerimientos complejos de la tecnología moderna. En este siglo el avance ha sido notable, utilizando materiales naturales de tierra para construir terraplenes para presas; y el concreto ha reemplazado las piedras labradas en la construcción de -- pequeñas y grandes presas de gran variedad de formas geométricas.

En la historia de la construcción de presas, ciertamente muchos cientos de ellas, y si se incluye muchos terraplenes pequeños, en la cuenta, pasan de miles las presas que han fallado. No hay un registro exacto de la mayoría de las fallas y extensión de daños. Desastres debidos a presas y embalses de las cuales existe cuidadosa documentación, indican una variedad de causas dentro de las estructuras mismas o de su cimentación.

En muchas partes del mundo, especialmente en zonas densamente pobladas, y áreas industrializadas, muchos o la mayoría de los sitios buenos para presas y almacenamientos, han sido ya utilizados, y los sitios restantes, generalmente adolecen de defectos geológicos en la cimentación o falta espacio para el embalse y se están requiriendo -- en constante aumento, investigaciones cuidadosas por los métodos más avanzados de las ciencias geológicas e ingeniería, primeramente para el diseño y después durante la construcción para hacer seguros completamente los embalses y obras, que planteen solamente muy poca -- amenaza para aquellos quienes viven y trabajan en la trayectoria de la corriente causada por una falla de una presa o embalse.

Presas, embalses y cimentaciones en las cuales ellos inevitablemente se soportan, experimentan cambios con el tiempo. Algunos de estos cambios son -- lentos y sutiles y no revelan su existencia, a no ser que se monitoricen en forma constante y precisa.

Otros, como aquellos causados por temblores y derrumbes y -- flujos inesperados son de corta duración y usualmente no pueden -- ser anticipados, a pesar del hecho que la calidad de conocimientos -- concernientes a su predicción está constantemente experimentando -- su mejoramiento.

La responsabilidad en la construcción de una presa con las -- máximas previsiones de seguridad y de la constante supervivencia -- crítica de la presa y cimentación, durante su vida útil, no debe ser mayor sólo para el Ingeniero que construye la presa; sino que es compartida por aquellos quienes tienen conocimientos especiales de hidrología, geofísica, geología y mecánica de rocas y suelos.

ASPECTOS GEOTECNICOS DE UNA PRESA Y CONSTRUCCION DE EMBALSES.

La construcción de una presa y obras conexas, y, si se requie-- re también el mejoramiento del sitio del embalse atrás de la presa, trae consigo marcadamente todos los esfuerzos necesarios en las -- investigaciones de campo y laboratorio, y en el diseño y estimacio-- nes de cantidades y costos.-- En las excavaciones de la cimentación y empotramientos de la cobertura superficial suelta o suelo, y de -- los dentellones y trincheras en la roca o en depósitos sueltos o -- en la remoción de roca intemperizada o fracturada, se producen des-- cubrimientos expuestos continuamente que revelan detalles de su lo-- calización exacta y propiedades físicas de los materiales abajo -- de la superficie, que pudieran o ~~no~~ ser anticipadas ^{o No} sus caracterís-- ticas cualitativas o cuantitativas en las investigaciones prelimi-- nares no obstante que estas fueran cuidadosamente conducidas. Los -- problemas, hayan sido anticipados o nó, ahora llegan a ser proble-- mas de campo de urgencia inmediata y requieren soluciones prácticas, involucrando hombres, equipo, tiempo de programa y procedimientos -- convencionales o altamente innovados. Innumerables métodos de cons-- trucción registrados en el mundo, publicados y medidas especiales que han sido empleadas para superar los problemas en presas y -- embalses realizados, SIRVEN PARA ENFATIZAR EL HECHO DE QUE NO HAY

EN NINGUNA PARTE DEL MUNDO, DOS SITIOS DE PRESAS Y EMBALSES IDENTICOS.

Así, en muchas clases de construcción pesada, personas con amplia experiencia han llegado a suponer lo insperado por la simple razón que los fenómenos naturales comunmente, no son sujetos a fáciles apreciaciones preliminares o jerarquización por parámetros arbitrarios establecidos por geotécnicos e ingenieros.- La construcción de una presa, en adición a los preparativos de la cimentación, - usualmente traen consigo una variedad de operaciones preliminares, incluyendo la construcción de caminos de acceso, procesamiento de materiales de construcción y construcción de desvíos, tales como ataguías y/o túneles o conductos de superficie.- Los problemas especiales y técnicos asociadas con cada una de estas operaciones, no es tema de esta conferencia. En su lugar la atención será enfocada al tratamiento de campo de la cimentación y empotramientos para mejorar su resistencia y para reducir o eliminar filtraciones subterráneas.

EXCAVACION DE LA CIMENTACION.

Basados en las investigaciones preliminares, un programa de las excavaciones de la cimentación se inicia con la suposición de que el volúmen del material excavado y de la configuración de la excavación, se predecirá aproximadamente en forma razonable o en las estimaciones de los planos y especificaciones. Generalmente es la responsabilidad del Ingeniero constructor establecer los taludes de la excavación que serán permanentemente estables o que no fallarán durante la construcción.- En materiales de tierra: taludes de 1.5:1 a 2:1 son excavados en cortes permanentes, y, taludes de 1:1 (45°) se establecen en cortes temporales, excepto donde se anticipan condiciones de estabilidad no usual. Si la roca no está muy fracturada, y no contiene planos inclinados de deslizamiento potenciales, tales como planos de estratificación en rocas suaves, los taludes pueden ser cercanos a la vertical.

En cimentaciones sobre depósitos naturales de materiales no consolidados, las excavaciones pueden revelar materiales inadecuados ----

en forma localizada o extensa que requieran tratamiento especial o remoción total.

Materiales inaceptables o inadecuados en cimientos son materiales no consolidados, ricos en materia orgánica tales como tierra vegetal, detritus de pantano, o turba, depósitos sueltos de arena o limo, rocas deslizadas y escombros de talud, arcillas, plásticas, activas, sensitivas o arcillas expansivas. Condiciones -- pobres de cimentación en rocas, están asociadas con fracturamiento cercano, intemperización o alteraciones^{por} del agua y temperatura o rocas sedimentarias pobremente endurecidas.

Las excavaciones en el lecho, en toda la extensión posible, se llevarán hasta la roca firme y fresca (no alterada por el intemperismo). Zonas estrechamente fracturadas hacia abajo, especialmente si contienen materiales suaves alterados, tales como capas de arcillas (salbandas) o productos de intemperización deberán ser removidos en toda la extensión posible. EL OBJETIVO DE LA EXCAVACION EN LA CIMENTACION, ES PREPARAR UNA SUPERFICIE LIMPIA QUE PROVEA UN CONTACTO OPTIMO CON LOS MATERIALES DE LA PRESA, YA SEA DE TIERRA O DE CONCRETO, QUE SEAN COLOCADOS SOBRE ELLA. Cuando la capacidad de resistencia es un factor a ser considerado, un tratamiento por inyecciones o por anclas de varilla de acero o cables de acero, puede ser necesario. Una exposición prolongada tanto del terraplén como de la roca de cimentación con la atmósfera o con acumulaciones de agua frecuentes, resultan en una deterioración por hidratación, deshidratación, congelación, contracción superficial y expansión por los cambios de temperatura. Es una buena práctica proteger las superficies reactivas que serán expuestas por -- intervalos prolongados de tiempo con gunita o concreto lanzado ó con materiales bituminosos. Alternadamente la cobertura vegetal original no debe ser removida hasta la limpieza final y justo -- antes de la colocación de materiales.

CONSTRUCCION DE UNA PRESA SOBRE DEPOSITOS NO CONSOLIDADOS
(CASO DE CERRO DE ORO).

Idealmente, la excavación en depósitos no consolidados para el cimiento de una presa debe extenderse al lecho sólido de roca en el ancho total de la cortina, ya sea construída de concreto, de tierra y o/enrocamiento.- Sin embargo hay muchos sitios donde la profundidad del relleno del valle es tan grande que las presas deberán ser construídas en parte o enteramente sobre depósitos no consolidados y por lo tanto requiera la cimentación, que se tomen pasos apropiados para mejorar las propiedades ingenieriles de los materiales del desplante y para reducir las filtraciones a través de estos materiales o de su contacto con la roca basal a niveles permisibles. Excepto para presas bajas de poco peso, presas de concreto no se hacen sobre rellenos no consolidados a causa generalmente de su baja capacidad de resistencia. Presas grandes que se construyan enteramente o en parte sobre rellenos no consolidados deberán ser sin excepción de tierra o de enrocamiento con capacidad propia de ajustarse a los asentamientos de los materiales de la cimentación.

Las figuras (10-1) muestran varias secciones de cortinas de tierra y/o enrocamiento, construídas por lo menos en parte sobre depósitos subsuperficiales no consolidados; Las secciones muestran varias medidas que son tomadas para eliminar o reducir grandemente filtraciones potenciales por debajo de la presa, en una gran variedad de circunstancias.- Es claro que se debe obtener bastante información como la distribución y permeabilidades de los materiales de los substratos antes del diseño y construcción de las trincheras principales.

OPERACIONES DE INYECTADO EN EL LECHO DE ROCA.

La meta del tratamiento de inyecciones en el cimiento y empotramientos del lecho de roca, es el mejoramiento de la resistencia y capacidad de apoyo de la roca y rellenar con lechada los --

canales y caminos subterráneos (vías de agua) que sean un potencial paso de filtración impermisible. En algunas circunstancias el anclaje con varillas de acero y/o cables de acero son usadas para mejorar la resistencia del lecho rocoso, pero la técnica más útil de aplicación general utiliza perforaciones e inyecciones a presión ya sea de mezclas de agua-cemento (lechada) o de otros tipos de sellantes. Las investigaciones geológicas y geofísicas preliminares usualmente revelan las características generales de la roca de fundación y empotramientos y facilita la identificación de las zonas potenciales de filtración. Sin embargo, muchos pequeños detalles, pero importantes de la geología pueden no ser revelados hasta que las excavaciones han sido realizadas y todos los materiales sueltos se han removido de tal modo, que la superficie de la roca pueda ser examinada. Esto es un tiempo crítico en la construcción de la presa porque el constructor está usualmente muy apurado para iniciar la construcción de la cortina y no con buenos ojos cualquier retraso aunque por examen de la roca indique la necesidad de un mayor y extenso tratamiento de la cimentación consumiendo tiempo, para prevenir indeseables y peligrosos flujos de agua; sin embargo, no se podrá dejar de insistir que nunca otra vez en la vida de la presa será posible examinar en detalle y tomar los pasos apropiados necesarios para corregir condiciones adversas que son reveladas en el descubrimiento de la superficie del lecho rocoso y considerando la vital importancia de tomar medidas correctivas adecuadas antes de que la cortina sea construída y el embalse llenado, los programas de construcción deben ser tentativos cuando se requiera un tratamiento extensivo que garantice la seguridad definitiva de la presa.

La lechada es un líquido ya sea de una sustancia química uniforme o una suspensión acuosa de sólidos que se inyectan dentro ---

de la roca o materiales no consolidados a través de barrenos -- especialmente perforados para mejorar las propiedades físicas -- de la masa y/o para reducir o eliminar filtraciones de agua -- subterránea. Los materiales de inyección son de 3 tipos básicos: 1).- Lechadas a base de cemento Portland.- 2).- Soluciones químicas inyectables y, 3).- resinas orgánicas, incluyendo resinas epóxicas (polímeros).- Las lechadas de cemento Portland, son por mucho las más ampliamente usadas en inyecciones y por adición de varias sustancias tales como arcilla, arena y bentonita o adición de sustancias químicas para incrementar o reducir el tiempo de -- fraguado, son usados en un amplio rango de aplicaciones. Materia-- les inyectados a base de sustancias químicas y agua son usados -- inicialmente donde se tengan aberturas intersticiales o grietas -- que son tan pequeñas que ellas no permiten la circulación y pene-- tración por partículas en suspensión. Comúnmente dos soluciones -- químicas son mezcladas inmediatamente antes de, o durante la in-- yección, tal que fragüe o precipite los componentes disueltos en el sitio deseado. Una solución química común contiene silicato -- de sodio el cual es convertido a un gel por una disolución catali-- zadora en una segunda solución. Excepto en circunstancias muy excepcio-- nales, resinas orgánicas son raramente usadas en cimentación de pre-- sas a causa de su alto costo. Un resumen del empleo de materiales formando polímeros en el mejoramiento de la resistencia de los -- poros de la roca ha sido preparado por Crow y Kelsh (1971).

En la cimentación de presas se distinguen tres clases de programas de inyecciones. (1) Inyectado sistemático relativamente a -- baja profundidad en "tapete" o inyectado de "consolidación" sobre porciones críticas de la cimentación, (2).- "cortinas" de inyección (pantallas) desde galerías o superficie con una capa de concreto -- (rellenos) a lo largo de zonas especificadas para producir una -- profunda barrera al paso de filtraciones subterráneas y (3).- In-- yecciones "fuera de plantilla" o extras para propósitos especiales

para mejorar resistencia y/o resolver problemas creados por circulación de agua subterránea en zonas identificadas por los estudios geotécnicos de campo.

Aunque la inyección de la roca de cimentación puede ser dirigida con meticoloso cuidado, siempre existe la posibilidad de que algunas vías de agua subterránea permanezcan circulando y que el flujo a través de éstas vías se aceleren con el llenado de -- embalse.- Si el volumen de flujo resulta ser excesivo durante el llenado del vaso pasos inmediatos para remediar deben ser tomados, pero, si los gastos son pequeños o insignificantes, ellos pueden ser interceptados y desviados por barreras de drenaje o prismas porosos. La intercepción y desvío provee una oportunidad de constante observación monitorizando el paso de las filtraciones por debajo de la cortina como una variación con el llenado o descenso del embalse atrás de la presa.

En las figuras se ilustran varias secciones hipotéticas de presas construídas, mostrando sobre el lecho de roca la localización de barrenos de inyección en la cimentación y barrenos o prismas de drenaje. Se designa con letra por separado las varias clases de agujeros como sigue:

"A".- Perforaciones de pantalla.- "B".- Perforaciones de inyección de tapete.- "C".- Perforaciones "extras" de inyectado para propósitos especiales; "D".- Perforaciones de drenaje.-

INTERVALOS DE INYECCION CON OBTURADORES.-

En las inyecciones de tapete especialmente donde la cimentación expuesta facilita la observación directa de las consecuencias de la inyección de lechada, generalmente no hay necesidad de localizar la penetración en el material de sub-base por el uso de obturadores.- En contraste, el conocimiento de zonas permeables profundas en ciertos agujeros inyectados, es esencial para el control -- eficiente de la profundidad de perforaciones intermedias en una plantilla de perforación cerrada.-

Dos métodos son usados en común en el confinamiento de la lechada de inyección para fijar intervalos en pantallas y en perforaciones extras de inyección profunda. En un método la perforación de inyección es barrenada totalmente en toda su profundidad y el inyectado es realizado por elevaciones sistemáticas o bajando en la perforación dos obturadores a una distancia fija aparte, digamos 5 metros. Este método tiene la desventaja de que la cortadura de la broca tiende a rellenar las aberturas en las paredes de la perforación en su porción superior e impide la entrada de las suspensiones de la lechada. Además, si se tienen dificultades en la perforación del barreno, tal vez a causa del fructuramiento cerrado de la roca, medidas especiales, tales como cementar pueden ser requeridas para superar la dificultad y puede reducir la toma total de lechada.

El segundo método, es preferible, utilizar un simple empaque el cual se fija al intervalo recién perforado de 3 a 5 metros de perforación y en una ^{sección} ~~sección~~ de perforación previamente inyectado por el mismo procedimiento.

Este método permite acercarse a la estimación de la localización de zonas permeables y al mismo tiempo facilita la eficiente penetración en el tramo de perforación que podría tender a derrumbarse durante la perforación o que contenga agua subterránea a presión.

PLANTILLA DE INYECCION.

Los planos para las presas comúnmente incluyen amplias especificaciones de un programa sistemático de tapete y/o pantalla de inyección. No obstante, a causa de la incertidumbre de las condiciones que serán encontradas durante las operaciones de inyectado, el número y profundidad de las perforaciones de inyección no se establecen con precisión.- En su lugar, la responsabilidad para el adecuado y completo programa se delega al campo o ingeniero de construcción quien está instruída para dirigir las operaciones de inyectado "como se requiera" o -- "como sea necesario".

Excepto, cuando las circunstancias sean favorables, las predicciones exactas de las cantidades de lechada que se requerirán son extremadamente difíciles. La "toma" de lechada en cantidades moderadas o muy grandes, en exceso a las estimaciones hechas con anterioridad a la construcción es una experiencia común, y confirma ampliamente un dicho que prevalece que la "inyección es un arte y no una ciencia".

La "plantilla se incluye en los planos de inyección y especificaciones para una presa, y comunmente es la base para estimar con anterioridad a la construcción, el total de metros de perforaciones de inyección y la cantidad esperada de consumo de lechada.- Es práctica general disponer la localización de las perforaciones de inyección, en los planos, en una plantillas sistemática definidos los espaciamientos y profundidades consideradas. Si se tiene suficiente información geológica, la localización y profundidad de la plantilla de perforaciones, toma en cuenta los tres dimensiones geométricas de las características geológicas.

Ejemplos de la localización de plantillas de perforaciones de inyección como se indican en planos y especificaciones para varios tipos de presas, son mostrados en las figuras 10-3 y 10-5. Los dibujos son enteramente esquemáticos, fuera de escala, sobre la consideración que el número real de perforaciones será determinado por el área de la sección de configuración de la excavación del cimiento de la presa. En adición, se considera en cada ejemplo que la cimentación está ya en roca, de tal modo que tanto el tapete como la pantalla de inyección son los anticipados en los planos y especificaciones.

TAPETE DE INYECCIONES.

Las perforaciones para inyección en "tapete" (perfs. "B") usualmente son de poca profundidad no mas de 5 a 10 metros y son utilizados para remediar los defectos de la cimentación, tales como fracturas en la roca reduciendo la permeabilidad y aumentando su resistencia.

Aunque las perforaciones de tapete pueden ser barrenadas normales a la superficie de la cimentación, hay considerables razones en dirigir las perforaciones para intersectar características específicas locales identificadas en el cimiento de la presa durante la excavación.

El tapete de inyección debe terminarse antes de la construcción de la Cortina.

PANTALLA DE INYECCION.

La pantalla de inyección en presas de tierra y/o de enrocamiento se termina usualmente antes de que la presa sea construída y se ejecuta desde un dentellón de concreto excavado en zanja sobre la superficie tratada de la trinchera. Una notable excepción para el tiempo normal de las operaciones de inyectado, es el inyectado después de la construcción desde un dentellón de concreto excavado en zanja en el talón de aguas arriba de una presa. Un ejemplo de inyección desde una zanja rellena de concreto (dentellón) excavada en el cimiento en una presa grande de tierra es el caso de la presa Dillon, Colorado en EE. UU. donde se inyectó desde un dentellón en el lecho de roca, en el fondo de la excavación de un depósito de grava.

Las pantallas de inyección de la cimentación de una presa de concreto es más efectiva después de terminada la presa, en el tiempo en el cual la carga total de la presa está ejerciendo sobre la cimentación. En tales circunstancias altas presiones de inyección se pueden emplear tal que garantice el máximo recorrido de la lechada en todas direcciones a lo largo de las trayectorias del flujo intersectados por las perforaciones de inyección.

En las presas de gravedad y arco gravedad de mediano tamaño o grandes, es práctica común construir una galería en el interior de la presa para de ahí barrenar perforaciones de inyección (Perf. "A") y perforaciones de drenaje (Perf. "D").

En el cimiento de pequeñas presas de gravedad y presas de arco delgadas, las inyecciones se pueden efectuar desde un dentellón a lo largo del contacto del paramento de aguas arriba de la presa, con la roca.- A falta de datos geológicos que indiquen otra cosa, la profundidad de las perforaciones de la plantilla de inyección de pantalla se determina por fórmula.- Una fórmula comunmente empleada establece que la profundidad vertical de la pantalla de inyección deberá ser un tercio de la altura de la presa a partir de la elevación del brocal de las perforaciones más 15 o 20 metros.- En donde las condiciones geológicas de la cimentación son conocidas, las profundidades de las perforaciones de pantalla no se basan en una fórmula, sino que, son determinadas por la localización a profundidad de los accidentes geológicos que requieran inyección de lechada para remediar o mejorar sus propiedades físicas, para reducir o eliminar potenciales filtraciones subterráneas a través de ellas.

El espaciamiento y secuencia de la plantilla de perforación e inyectado de pantalla en las perforaciones, ya sea desde un dentellón o galería es de suma importancia.- Generalmente se planean plantillas de perforaciones de pantalla espaciados 3 M. descomponiendo la medida de distancia entre ellos como una distancia inclinada o una distancia horizontal con la estipulación de añadir perforación donde se requiera.- Es práctica aceptada la secuencia de barrenación e inyectado, controlado por una plantilla cerrada a unos 24 metros de separación para un lecho de roca de propiedades uniformes y baja permeabilidad promedio.- En la figura ⁽¹⁰⁻⁷⁾ se considera que la toma de lechada en cada perforación es insignificante y que, como la plantilla es cerrada, las perforaciones son barrenadas sucesivamente a menor profundidad según la fórmula de profundidad.- En un ejemplo real la determinación de la profundidad de las perforaciones intermedias se controla por la experiencia en las perforaciones precedentes, así otorgando gran versatilidad al procedimiento.-

Excepto en situaciones donde los materiales de la cimentación son uniformes y las estructuras geológicas son muy simples, operaciones de inyectado y pantalla deben ser conducidas siempre y con una supervisión muy estrecha por un geólogo experimentado.- El conocimiento de las condiciones de la cimentación obtenidos durante las investigaciones preliminares y en las etapas de diseño casi invariablemente no proveen un entendimiento completo de la localización exacta, dimensiones y propiedades de las características geológicas subterráneas que puedan promover ajustes en la cimentación durante la carga o permitiendo filtraciones excesivas.

Examinando los fragmentos de las perforaciones de inyección y si se juzga necesario, la recuperación y examen de núcleos, se facilita el registro de los rasgos gruesos y de pequeña escala que contribuyan a aumentar la apreciación de los detalles geológicos subterráneos y su reconstrucción cada vez mas precisa.

La prueba de agua a presión no se requiere porque el consumo de lechada medida sirve al mismo propósito particularmente si las mezclas iniciales son delgadas.

Las figuras 10-8 sugieren los requerimientos de consideraciones cuidadosas de la geología subterránea en su localización y determinación de la profundidad de la pantalla en una variedad de situaciones tales que peligrosas y potenciales filtraciones por debajo o a los lados de los límites de la profundidad de la pantalla por medio de la fórmula pueden ser reducidas o eliminados. Solamente perforaciones de localización especial o de profundidad (líneas fuertes) en exceso de aquellas calculadas por la fórmula se muestran en la figura 10-8.- Se consideró que el espaciamiento de la plantilla y las profundidades por medio de la fórmula de las otras perforaciones se mantendrán para la pantalla completa de toda la cimentación.

EJEMPLOS DE PANTALLAS DE INYECCIÓN.

Las figuras 10-9 . 10-12, ilustran ejemplos de pantallas de inyección en las cuales la profundidad, la presión de inyectado, y la consistencia de las lechadas, fueron controladas por la geología de la cimentación. En cada ejemplo un entendimiento de la geología de la cimentación se obtuvo de los núcleos de las perforaciones de exploración anterior al diseño y construcción de la presa, mapeando los detalles geológicos de la superficie antes y durante la construcción y continuando las observaciones del progreso de las operaciones de inyectado. En cada presa una plantilla cerrada a 24 metros fue empleada, y como se fue requiriendo, perforaciones adicionales se hicieron para remediar condiciones especiales.

La figura 10-9, ilustra el resultado de pantalla de una parte de la cimentación de la presa Dillon en Colorado. Una presa de tierra situada sobre una sucesión de fallas inclinadas, y, en el sitio, estrechamente fracturadas, las roca sedimentarias. Un problema particular se presentó por el fracturamiento cercano en las areniscas frágiles y cuarcitas en la formación Dakota, Fig. (10-10), en la cual, antes del inyectado tenían alta permeabilidad de circulación de agua - subterránea.

En la figura (10-11), está en proyección en un plano vertical la pantalla de inyección de la presa Williams, Fork, Colorado, una presa en arco de pared delgada. Las perforaciones para inyección fueron barrenadas desde un dentellón en el contacto de aguas arriba de la presa con la roca a un ángulo de 60° de la vertical e inclinadas sobre la presa.- Preliminarmente las investigaciones geológicas y exámen subsecuente de la cimentación durante las excavaciones, revelaron la existencia de un sistema de fallas esencialmente verticales de pequeño desplazamiento e intersectando gneises metamórficos cristalinos y esquistos.- La dirección de las fallas está generalmente cruzando el eje de la presa y sus existencia crec la probabilidad de fuertes filtraciones por debajo de la presa por lo menos donde ellas fueron sellados con lechada.

Durante las operaciones de inyectado, una falla de gravedad por deslizamiento, no conocida previamente su existencia, fué descubierta y tratada.-

La figura (10-12), muestra una porción de la pantalla de -- inyección perforada desde una galería en la presa Gross, Colorado, una cortina de concreto de arco-gravedad descansando sobre un granito masivo.- La penetración de la lechada fue especialmente notable a lo largo de una falla de gravedad por deslizamiento inclinada hacia el piso del cañón.-

INYECCIONES EXTRAS PARA PROPOSITOS ESPECIALES.

Durante las investigaciones anteriores a la construcción de la presa, o como condiciones geológicas imprevistas se manifiesta en -- la excavación de la cimentación, la necesidad de perforaciones -- "extras" para propósitos especiales (perf. "C") que pueden llegar a ser evidentes.- Estas perforaciones son barrenadas e inyectadas para mejorar la resistencia y/o reducir la permeabilidad de la roca que no son intersectadas por perforaciones de tapete o pantalla.

Ejemplos de condiciones de cimentación que requieren inyectado "extra" se muestran en la fig. 10 - 13 .- La profundidad, dirección, e inclinación de las perforaciones se determinan por la geometría - tridimensional de las zonas incompetentes y/o rocas permeables así reveladas por la observación de campo del lecho rocoso expuesto en las excavaciones de la cimentación y comportamientos.-

CONSISTENCIA DE LA LECHADA Y PRESIONES DE INYECTADO.

El propósito del inyectado de la cimentación es el mejoramiento del aumento de resistencia de los materiales de la cimentación, y generalmente considerando aún más importante, el llenado y sellado de vías potenciales de filtración. Para realizar este -- propósito en muchas circunstancias, requiere del ejercicio de una gran habilidad y juicio en la localización de las perforaciones, -- control de presiones de inyectado y de consistencia de lechadas.-

La localización y profundidad de las perforaciones se determinan por el conocimiento de las condiciones geológicas locales y por la experiencia obtenida durante el progreso de las operaciones de inyectado con una cuidadosa supervisión, excepto las presiones y consistencia de las lechadas deberán basarse en consideraciones -- altamente subjetivas.- En su realización, no es sorprendente, que existan amplias divergencias de opinión y de procedimientos presentes para el control de superficie de las operaciones de inyectado.

La habilidad de la lechada de cemento para penetrar espacios abiertos interconectados está limitada por las dimensiones de los espacios abiertos y de la cantidad y medida de las partículas de cemento suspendidas en la base de agua.- Aberturas ligeramente más grandes que el tamaño capilar pueden permitir la libre circulación del agua subterránea ^{pero} son rellenos rápidamente y obstruidos por las partículas de cemento y el transporte lateral y/o vertical de la suspensión de lechada es grandemente impedido o parado. En aberturas mas grandes presuponiendo vías interconectadas de circulación, la suspensión de lechada se mueve con facilidad y en algunos casos viaja sorprendentemente grandes distancias.

Si la circulación fácil continúa con el progreso de las operaciones de inyectado, la suspensión es gradualmente espesada y -- si es necesario la presión correspondiente incrementada hasta que el relleno de las aberturas posibles, se indica por el rechazo de la perforación para aceptar lechada adicional. Escapes de lechada en la superficie deberán ser calafateadas o de alguna -- otra manera selladas para fomentar el confinamiento subterráneo de la lechada.-

La definición de "delgada" y "espesa" no son precisas pero, generalmente, mezclas "delgadas" son interpretadas para significar mezclas preparadas por mezclado de 8 a 10 volúmenes de agua por uno de cemento.-

Mezclas espesas tienen una proporción en volumen de agua-cemento de aproximadamente 1 : 1 , o espesuras que no sean mayores de tal modo que la lechada no pueda ser bombeada con facilidad.-

En la práctica la experimentación con proporciones de agua-cemento en las etapas iniciales de inyectado para determinar las condiciones óptimas para la circulación siempre es muy útil. En algunas circunstancias en rocas muy fracturadas, en rocas solubles cavernosas, tales como calizas y gravas de alta permeabilidad, son indicadas inicialmente mezclas espesas, y aditivos inertes, tales como arcilla o arena pueden ser añadidas a la suspensión de lechada como relleno económico.- La determinación de las presiones usadas en las operaciones de inyección requiere proceder con juicio, y depende de las condiciones naturales locales. Cuando las presiones de la lechada exceden de ciertos límites críticos, existe la posibilidad de que la roca de cimentación pueda ser dislocada, y se formen vías de circulación que no existían previamente. Las posibles consecuencias, del uso excesivo de las presiones en la lechada, se entiende por la referencia de la fig.10-14, en la cual se supone Fig. (10-14A) que la perforación intersecta una vía horizontal de circulación potencial de lechada, tales como fracturas planas o un plano de estratificación sedimentaria, y que Fig.(10-14B) una perforación similar intercepte un plano inclinado de circulación potencial.

En la Fig. (10-14A) la profundidad de una vía confinada horizontalmente se indica como (h) y se considera que la presión de la lechada en la perforación en el punto de entrada dentro de la vía es aproximadamente la misma que la presión indicada por el manómetro en la superficie. La entrada de lechada dentro de la vía disloca la masa de roca arriba de la vía, y por acción de cuña y ajustes locales, elásticos y/o plásticos en la roca tienden a ampliar la vía de manera que permita la difusión lateral de lechada. Así, por el movimiento de agua subterránea, las fricciones a lo largo de la vía reduce la presión del fluido en cualquier punto, en función de la distancia de la perforación, pero a medida que la vía se amplía, las fricciones llegan a ser del mismo orden de magnitud como la presión registrada en el manómetro.

La fuerza de elevación bajo la presión de la lechada en una vía horizontal puede ser fácilmente calculada en función de la presión de cualquier punto de la vía.

Considerando que la densidad de la roca es de 2.6, cerca del promedio del granito, la tabla 10-1 fué preparada e indica las alturas (h) de una columna de roca que puede ser elevada, como una función de la presión en cualquier punto a lo largo de la vía horizontal. La tabla se calculó determinando que la presión vertical ejercida por una columna de roca de densidad 2.6 se incrementa por 1.125 psi por pie de altura añadido.

TABLA 10-1

Altura de una columna de roca de densidad 2.6 que puede ser desplazada hacia arriba por lechada bajo presión en una vía confinada horizontal.

Presión (psi)	h (ft)
10	8.8
50	44.4
100	88.8
200	177.7
300	266.6
400	355.5
500	444.4
1000	888.8

En la Fig. (10-14 B) la vía inclinada a un ángulo ϕ de la horizontal es mostrado. La presión ejercida hacia arriba verticalmente de la lechada en cualquier punto de la vía se obtiene por multiplicación de la presión de la lechada por el $\cos \phi$. Claramente el peso de la columna de roca que se aproxima en cualquier punto decrece a medida que la lechada se acerca a la superficie, así se explica el incremento fácil del movimiento de la lechada hacia la superficie. Cuando $\phi=90^\circ$, tal que la vía de circulación es vertical, la presión completa de la lechada es dirigida horizontalmente, y grandes presiones son improbables que causen dislocaciones extensivas de la roca, excepto en valles de taludes escarpados.

A causa del amplio rango en complejidad de los sistemas de circulación subterránea no es posible establecer una fórmula rígida para controlar las presiones en la parte superior de la perforación. Por las razones subrayadas arriba, debe tenerse cuidado en mantener bajas presiones

de la lechada donde las perforaciones intercepten vías en el fondo de los valles y vías paralelas a lo largo de estos, especialmente durante el inyectado de tapete. Para las pantallas de inyección la regla que se sigue algunas veces establece que la presión en una lechada delgada inicialmente se incrementa hasta un nivel el cual establece una circulación libre (considerando presentes vías de circulación) pero no en exceso de la presión hidrostática calculada del llenado del embalse a la elevación de la boca del barreno más 10-50 psi. La presión hidrostática del agua incrementada 0.433 psi por pie de profundidad. Por supuesto la presión hidrostática de la lechada en la perforación se incrementa con la profundidad, pero esta presión usualmente se ignora.

A medida que las mezclas de lechada son espesadas y se aproxima la perforación al rechazo, la presión puede ser gradualmente incrementada, pero exceptuando perforaciones profundas en rocas de alta resistencia no deberá permitirse exceder una presión del doble de la calculada con la carga hidrostática del llenado del embalse a la elevación de la boca de la perforación más 10-50 psi.

Una experiencia no poco común es una caída rápida de presión en el manómetro cuando la lechada bruscamente fuerza su camino en una nueva vía de más fácil circulación. Cuando esto sucede, la presión de la lechada ~~es~~ ^{es} reducida y continuada a un nivel justo suficiente para mantener la circulación.

Prematuro espesamiento de la lechada o reducción de la presión para causar al rechazo en la perforación deberá ser evitado a menos que pueda ser demostrado que la lechada se está escapando a un pozo superficial fuera del área de fundación.

Mientras que la lechada está circulando a algún lugar de la cimentación o muy próxima a ella, se deberá considerar que esto está contribuyendo a un mejoramiento de las propiedades ingenieriles de los materiales de la cimentación y a una reducción en la permeabilidad de las filtraciones.

PERFORACIONES DE DRENAJE Y OBSERVACION, POZOS, Y PRISMAS POROSOS.

A pesar de los cuidados en las operaciones de inyectado del tapete y pantalla, existe la posibilidad, e indudablemente la probabilidad

de que no todas las posibles vías de circulación de agua subterránea hayan sido intersectadas y selladas por lechada. Apreciaciones de la efectividad de las operaciones de inyectado usualmente no es posible hasta que el embalse atrás de la presa esté parcial o completamente lleno. Por consiguiente es una práctica estandar, barrenar perforaciones, excavar pozos, o construir prismas de drenaje porosos aguas abajo de la pantalla de inyección para interceptar el agua subterránea que pase a través o por debajo de la pantalla y para facilitar la observación de los volúmenes cambiantes del flujo con el llenado y vaciado del vaso.

En una presa de tierra la cual cubre el dentellón, excesivas filtraciones a través de la pantalla después del llenado del vaso presenta un gran problema que puede no ser remediado por cualquier medio simple. Para prevenir así un acontecimiento es aparente que tanto la pantalla como el tapete antes del emplazamiento de la presa deberá dirigirse con gran cuidado y atención meticulosa para detallar la geología de la cimentación.

En presas de concreto gravedad y arco-gravedad las cuales contienen galerías de inyección y en las presas de arco delgados inyecciones de reparación utilizando la existencia de perforaciones de drenaje o barrenando nuevamente perforaciones, no presentan problemas insuperables.

REFORZAMIENTO DE LA ROCA POR ANCLAS Y CABLES.

Las masas de roca fracturada o rocas sedimentarias débiles en las cuales los planos de debilidad son inclinados hacia el fondo de un valle, y masa de roca compleja y densamente fracturada, sin hacer caso de la orientación de las fracturas ^{tienden} a ser inestables y pueden presentar una constante amenaza de colapso por falladura de talud, especialmente si sus propiedades son cambiadas por la exposición a la atmósfera o las masas son penetradas por el agua bajo presión del embalse. Si en el interior de las excavaciones rocas estratificadas y fracturadas son contenidas por la presa, las fallas de talud pueden no ser consideradas un problema. Afuera y arriba de la presa, sin embargo, masas inestables pueden llegar a ser activas como para causar un

llenado parcial del vaso, obstruyendo las estructuras de desvío, o daños físicos a la presa y obras auxiliares.

Aunque el confinamiento por la presa de masas muy fracturadas dentro de la cimentación previenen fallas de talud, tales masas pueden tener una capacidad de resistencia inadecuada y, si las fracturas son orientadas en direcciones críticas, pueden contribuir a una dislocación desigual y fracaso de una presa. El tratamiento de lechada de las fracturas de los materiales de la cimentación incrementa el aumento de resistencia y reduce permeabilidades, pero en algunos casos, el reforzamiento por anclas de varilla y/o cables de acero tensionados se requieren para estabilizar y proveer la resistencia adicional para el factor adecuado necesario de seguridad contra fallas ya sea en el cimiento de la presa o en su vecindad.

Las anclas y los cables, si son apropiadamente utilizados, incrementan la resistencia de las masas de roca por la tendencia a cerrar fisuras abiertas y por el aumento de la resistencia al corte a lo largo de fracturas y estratos débiles por incremento de la resistencia por fricción.

Las anclas y cables no serán efectivas si no son debidamente ancladas de tal modo que puedan ser tensionadas. Las anclas comúnmente tienen un dispositivo corto de anclaje por expansión en el extremo del fondo y requiere roca firme para su anclaje efectivo. Se está incrementando el uso de anclas de varilla y cables haciéndose el anclaje con resinas de rápido fraguado de alta resistencia. Las resinas funcionan bien aún en materiales de baja a moderada resistencia y tienen la ventaja de proveer tramos anclados de cualquier longitud deseada por control del volumen de la resina vaciada dentro del barrenado. Los cables se usan en perforaciones más profundas que aquellos barrenados para anclas de varilla, pero pueden ser usados en lugar de anclas de varilla bajo muchas circunstancias.

El uso propio de anclas o cables requiere del conocimiento de las propiedades friccionantes de los planos de debilidad y esfuerzos cortantes que causan dislocación a lo largo de éstos planos

El coeficiente de fricción estático, K (Fig. 10-15) por definición es la relación de la fuerza del corte, S , necesaria para iniciar el movimiento de una superficie sobre la otra, a la fuerza N , actuando normal entre las superficies de contacto y tendiéndolas a presionar una contra la otra.

Si convertimos la fuerza a esfuerzo por unidad de área y, tomamos en cuenta la relación angular en la figura (10-15), tenemos:

$$K = S/N = \frac{\tau_s}{\tau_n} = \tan \phi \quad (10-1)$$

En la Figura 10-15, S y N se consideran componentes vectoriales de la fuerza G de gravedad.

Después de que se inicia el movimiento a lo largo de las superficies de contacto bajo una fuerza dirigida paralela a S las relaciones de fricción se especifican por un coeficiente de fricción cinético, el cual generalmente tiene un valor mas pequeño que el coeficiente estático de fricción.

En el siglo dieciocho, Coulomb, un físico francés, observó que la resistencia al corte (resistencia cortante) asociado con deslizamiento de una superficie pasando sobre otra, depende de dos factores, los cuales él llamó fricción interna y cohesión respectivamente y estableció la relación empírica.

$$S = \tau_n \times \tan \phi + c \quad (10-12)$$

El valor de c depende de la tersura o rugosidad de las superficies en contacto, y en algunas situaciones de la presencia o ausencia de poros de agua o de un relleno de material débil tal como la arcilla.- La rugosidad de las superficies de contacto en substancias frágiles produce trabazón, los cuales resisten las dislocaciones hasta que ellas son removidas por frotamiento o trituración.- En muchas rocas los movimientos a lo largo de las fracturas es acompañado por una reducción en el valor de c , tal que, se aproxima a cero.- En cálculos de ingeniería destinados para garantizar un factor adecuado de seguridad, es práctica común despreciar el valor de c , donde así, valores para el esfuerzo cortante me

nores que el esfuerzo real.

El agua bajo presión en fracturas o en poros actúa reduciendo el esfuerzo normal efectivo en una cantidad igual a la presión. En la Fig. 10-15 las presiones piezométricas, positivas al vector de fuerza N , y actuando simultáneamente reducen el valor efectivo de \underline{G} y \underline{S} reduciendo así el esfuerzo cortante a lo largo de la superficie. Esta condición se expresa por :

$$S = (\bar{\sigma}_n - u) \times \tan \phi + c$$

en donde $\bar{\sigma}$ es la presión piezométrica.

El deslizamiento de una superficie sobre la otra puede ser inducida por incrementos de la fuerza S actuando en la dirección de la superficie de potencial dislocación o por incremento del ángulo ϕ de la superficie inclinada.- Fig. 10-15 ese ángulo de resistencia friccionante en el cual el deslizamiento espontáneamente puede ocurrir (ϕ) es algunas veces llamado ángulo crítico de reposo o más simplemente, ángulo de reposo y puede ser calculado de la ecuación 10-3, cuando S , N , u y c , han sido determinados experimentalmente ya sea por dislocación a lo largo de una fractura o a lo largo de un plano de debilidad de la roca, tales como planos de estratificación o foliación.

Los ángulos calculados de rocas en reposo, comunmente son del orden de 35° a 50° ; excepto en rocas débiles, incluyendo lutitas pobremente endurecidas y piedras arcillosas, las cuales pueden tener ángulos de reposo tan bajo como cerca de 20° .

En muchos materiales débiles no consolidados acuíferos el valor para ϕ crítico comunmente anda en el rango de 10° a 20° . En pendientes naturales en valles en los cuales hay fracturas o estratos de materiales débiles inclinados hacia el fondo del valle el ángulo de reposo raramente excede 40° .- Los ángulos mas altos de reposo son observados en rocas firmes en las cuales las superficies de contacto a lo largo de planos de fractura son rugosas y bien trabadas. Un pro-

cedimiento útil, es la medida en el campo de la inclinación de ángulos de estructuras planas los cuales fueron excedidos y que han resultado en fallas de talud.

Algunos ángulos críticos de reposo y el correspondiente coeficiente de fricción estático se dan en la tabla (10-2).

TABLA 10-2

ANGULOS CRITICOS DE REPOSO Y COEFICIENTES DE FRICCIÓN ESTÁTICA.

Ang. de reposo ϕ crítico (grados)	$K = \tan \phi$
10	0.18
20	0.36
30	0.58
40	0.84
50	1.19

El reforzamiento de la roca en taludes dentro y en la vecindad de las excavaciones de una presa se diseña para estabilizar y mejorar la resistencia de las masas rocosas en las cuales las fracturas o estratificaciones están inclinadas hacia el fondo del valle o para estabilizar masas completamente fracturadas las cuales podrían colapsarse por movimientos conjuntos ya sea espontáneamente o por causa de taludes muy escarpados o por remoción de soporte durante la excavación. Los procesos que promueven deslizamientos a lo largo de planos de fractura o debilidades reduciendo de hecho el ángulo crítico de reposo, incluyendo la penetración de agua bajo presión, humedecimiento y expansión de arcillas en rellenos, acción de congelación, y, donde las estructuras planas están casi en el ángulo de reposo, bruscamente se dislocan por temblores de tierra.

Cuando se usan anclas y cables para reforzamiento, éstas deberán ser instaladas cercanamente al ángulo recto a planos y fracturas de debilidad como sea posible.- La razón de esto llega a ser obvio de la inspección de la figura 10 la cual muestra una fractura inclinada de la superficie a un ángulo de 30°

El ángulo θ es ligeramente menor que el ángulo θ crítico, que es el ángulo de reposo, pero para estar del lado de la seguridad en los cálculos, θ se considera ser igual a θ crítico.- Realmente no ha habido deslizamiento a lo largo de la fractura porque θ es menor θ crítico por una pequeña cantidad desconocida.

En la figura 10-16 A, un diagrama de fuerzas, (1) da un coeficiente de fricción estática, K , igual a $S/N = \tan 30^\circ = 0.577$ considerando que el ángulo de reposo es de 30° . Resultado de la fuerza de gravedad, G , da una componente N , normal a la fractura y una componente S , la cual es la fuerza que tiende a causar el deslizamiento a lo largo de la fractura.- El efecto de cohesión c , en la ecuación (10-2), no se considera. En la figura 10-16 A un ancla tensionada produce una fuerza F , actuando en la misma dirección como, N , y arbitrariamente fijada igual a N .- A causa de que S permanece constante y la fuerza normal a la fractura es ahora $F + N = 2N$, un nuevo diagrama de fuerzas (2) resulta y el valor de $\tan \theta = S/F+N = 0.27$ el cual corresponde al coeficiente de fricción y al ángulo de reposo de un material hipotético mucho más débil que el material real bajo consideración.

Para determinar la fuerza, S' , necesaria para iniciar el deslizamiento a lo largo de la fractura después de instalada y tensionada el ancla, otro diagrama de fuerzas (3) se construye. De las relaciones $K = S/F+N = \tan 30^\circ = 0.577$ se determina que $S' = 2S$, esto es, instalando y tensionando el ancla, se ha duplicado la resistencia al cortante a lo largo de la fractura.

En la Fig. 10-16 B, el ancla se instaló verticalmente, paralela a la dirección de la fuerza de gravedad, G .

El diagrama de fuerzas (1) antes de la instalación del ancla es idéntico con el diagrama de fuerza inicial de la Fig. 10-16 A. El diagrama de fuerzas 2, se considera arbitrariamente que la fuerza ejercida por el ancla, F , es igual a la fuerza de gravedad, G , y una nueva fuerza cortante, S'' , se calcula.

Sin embargo, aunque S'' es el doble de S , la relación S''/N'' en el diagrama de fuerzas 2 es el mismo como S/N en el diagrama (1) y ambas relaciones igual a K , el coeficiente de deslizamiento de fricción. Así la sola contribución que el ancla hace para prevenir el deslizamiento es la resistencia de la propia ancla, excepto, posiblemente de un incremento en el valor de c , el factor de cohesión en la ecuación 10-2, o 10-3.

Usualmente no es posible calcular el espaciado y tensionado de las anclas (o cables de acero) requeridas para estabilizar y proveer un predeterminado factor de seguridad en rocas complejamente fracturadas. No obstante a veces la geometría del espacio facilita cálculos simples que prueban ser muy útiles. Un ejemplo está provisto en la Fig. 10-17, en la cual se consideró que una losa de roca está resistiendo muy cerca del ángulo de reposo sobre una fractura inclinada 35° hacia el fondo del valle y roturas paralelas al valle. Para propósitos de cálculo se consideró que la losa se extiende 15 m. paralelos al fondo del valle y las otras dimensiones son aquellas mostradas en el diagrama:

Datos pertinentes son como sigue:

$$\text{Volúmen de la losa} = 765 \text{ m}^3$$

$$\text{Peso (2 560 Kg/m}^3) = 1960 \text{ Ton.}$$

Area de la fractura por

$$\text{debajo de la losa} = 232.26 \text{ m}^2 = 2\,322\,576 \text{ cm}^2$$

$$K = \tan \phi = \tan 35^\circ = 0.700$$

Los cálculos basados sobre el diagrama de esfuerzos (1) en la Fig. 10-17 produce los siguientes números.

$$\sigma_g = (0.84 \text{ Kg/cm}^2)$$

$$\sigma_n = \sigma_g \cos 35^\circ = 0.84 \times 0.82 = 0.69 \text{ Kg/cm}^2$$

$$\sigma_s = \sigma_g \sin 35^\circ = 0.84 \times 0.57 = 0.48 \text{ Kg/cm}^2 \text{ y } \frac{\sigma_s}{\sigma_n} = \tan \phi = 0.700$$

Ahora suponga que se desea para incrementar σ_s por 50% por la instalación de anclas perpendiculares a la fractura y anclados en roca firme. Esto es, se desea determinar un valor de σ_n , diagrama de esfuerzos (2), el cual corresponde a $\sigma_n' = 1.5 \sigma_n = 1.04 \text{ Kg/cm}^2$ para un ángulo de reposo de 35° .

Por consiguiente ahora calculamos un valor para σ_n usando la relación $\sigma_s / \sigma_n = \tan \phi$, y concluimos que el ancla debe suplir un esfuerzo normal adicional a la fractura igual a 0.34 K/c^2 para realizar el objetivo deseado, así:

$$\text{Esfuerzo adicional normal deseado} = 0.34 \text{ Kg/c}^2$$

$$\text{Area de la fractura} = 2'322,576 \text{ cm}^2$$

Presión normal adicional deseada.

$$\text{sobre la fractura} = 2'322'576 \times 0.34 = 789'676 \text{ Kg (790 Ton).}$$

Supóngase que el ancla que se instalará debe ser tensionada a 4 530 Kg. Entonces para obtener el número requerido de anclas dividimos $789'676 \text{ Kg} \div 4'530$ y llegar a 175 anclas, esto es aproximadamente un ancla por 1.33 m^2 . Además, incrementando el esfuerzo cortante a lo largo de la fractura está la resistencia del ancla misma la cual deberá ser cortada antes de que el movimiento se inicie. En muchas situaciones la instalación de anclas requiere de cuidadosas evaluaciones subjetivas de las condiciones existentes. Comúnmente desconocidas son el ángulo de reposo el cual determina el coeficiente de fricción, la geometría exacta y resolución de fuerzas en masas complejamente fracturadas, la extensión para el cual los poros de agua bajo presión pueden modificar σ_n y el valor de c en la ecuación 10-3.

Combinando inyectado con anclas o cables instalados se producen excelentes resultados. En taludes inestables el inyectado se hace después de la instalación de las anclas. En masas confinadas muy fracturadas el inyectado de la cimentación deberá ser primero y seguirse con la instalación de anclas tensionadas o cables para obtener resultados óptimos. Varios ejemplos del uso de anclas y cables de acero se muestran en la Fig. 10-18.

ESTABILIZACION DE TALUDES EN EL VASO.

Donde existe la posibilidad de fallas masivas en taludes del vaso, ya sea vacío o lleno, se deberán tomar pasos apropiados para estabilizar los taludes.- El remedio particular que se emplee en cada caso depende de la naturaleza de las condiciones locales. Excavaciones o anclajes de acumulaciones inesta--

tables de materiales no consolidados y excavaciones o estabilización por inyectado, anclas o cables de acero en taludes inestables de roca deberán ser considerados como rutina en situaciones donde a corto o largo plazo la integridad del vaso es amenazado por fallas de talud.

INFORME FINAL DE CONSTRUCCION.

En adición para un resumen de todas las operaciones de ingeniería y "como se hizo"; los dibujos al final del informe de construcción deberán contener meticulosamente preparado, mapas y secciones de la cimentación y empotramientos de la presa y de las obras auxiliares; tabular y narrar condensadamente todos los aspectos de construcción relacionados al tratamiento de los materiales de la cimentación para mejorar su resistencia o para reducir filtraciones subterráneas.

- o -

REFERENCIAS.

Ernest E. Wahlstrom.- Dams, Dam Foundations and Reservoir Sites.

Elsevier scientific publishing company 1974

D.P. Krynine and W.R. Judd.- Principios de Geología y Geotecnia para Ingenieros

Ediciones Omega, S. A. 1961.

H. Cambefort.- Inyección de Suelos.- Ediciones Omega, S. A. 1968.

Consultivo Técnico S.R.H.- Instrucciones sobre las operaciones de Inyectado 1963.

Journal ACI.- Notes on the Theory and Practice of Foundation Grouting.

By V.L. Minear.- Vol. 18 No. 8.- Abril 1947.

ASCE.- National Structural Engineering Meeting.- Potentially Active Faults in

dam foundations.- By James L. Sherard and Lloyd S. Cluff April 9-13 1973

Meeting preprint 1948.

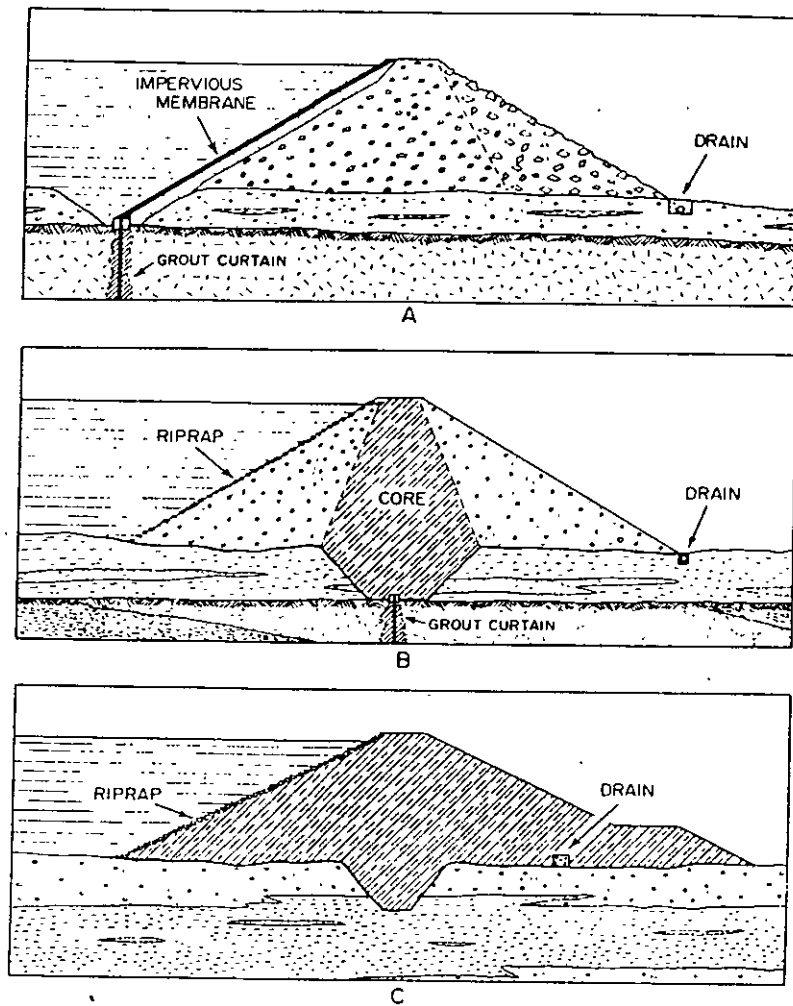

Fig. 10-1. Secciones de presas de tierra y enrocamiento sobre depósitos no consolidados.-

- A.- Presa de enrocamiento. La membrana impermeable (de concreto asfáltico) se extiende desde un dentellón en el lecho de roca.-
- B.- Trinchera que se extiende hasta la roca basal.
- C.- Trinchera que penetra a una capa impermeable de un relleno no consolidado.

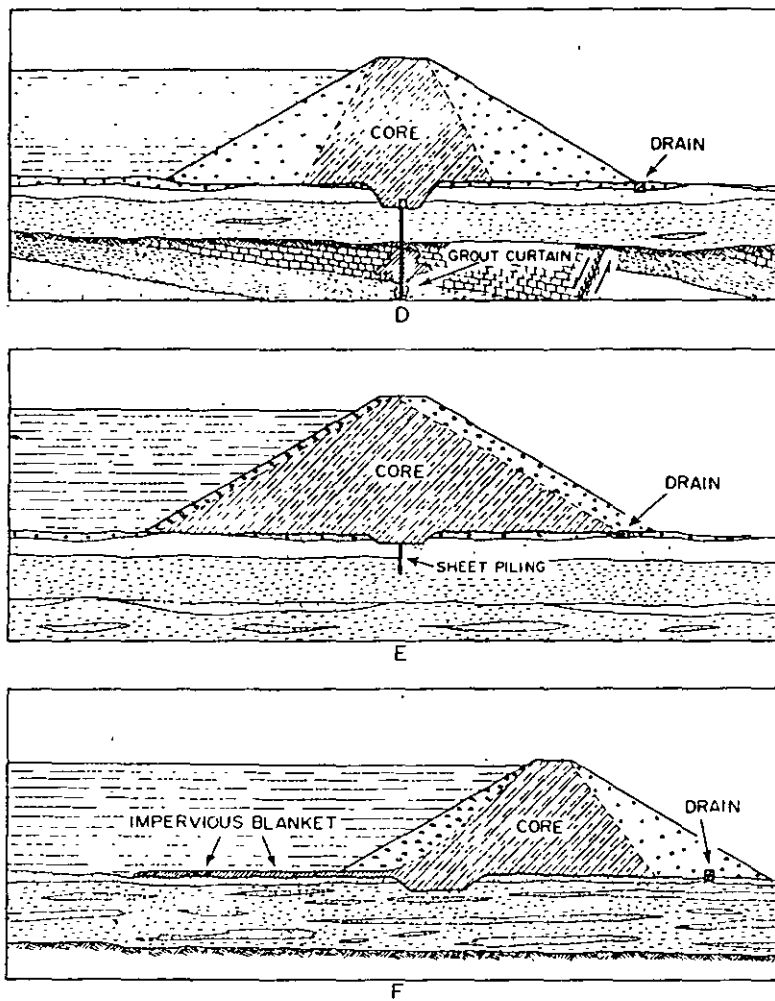

Fig. 10-1. (continuación)
Secciones de presas de tierra y enrocamiento sobre depósitos no consolidados.-

- D.- Trinchera que se extiende a una capa de material impermeable no consolidado.- Las perforaciones de inyección se extienden a través de una capa de caliza de la roca basal abjo del relleno.
- E.- Una trinchera está provista por un tablaestacado hincado en una capa de material impermeable.-
- F.- El flujo por debajo de la presa es reducido por una capa de material impermeable colocado aguas arriba de la presa (delantal impermeable).

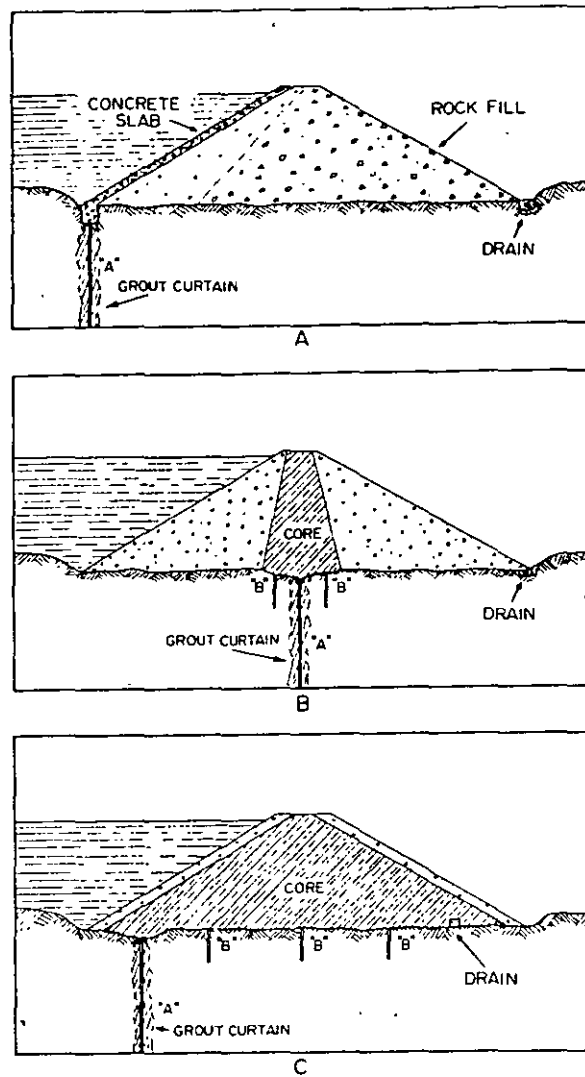

Fig. 10-2. Algunas secciones de presas con la roca de cimentación mostrando las localizaciones de los barrenos perforados para el tratamiento de la cimentación.- Véase discusión en el texto para explicaciones de las designaciones de las perforaciones.-

- A.- Presa de enrocamiento con un talud impermeable de concreto.-
- B.- Presa de tierra zonal y enrocamiento.
- C.- Presa de tierra zonal y enrocamiento.

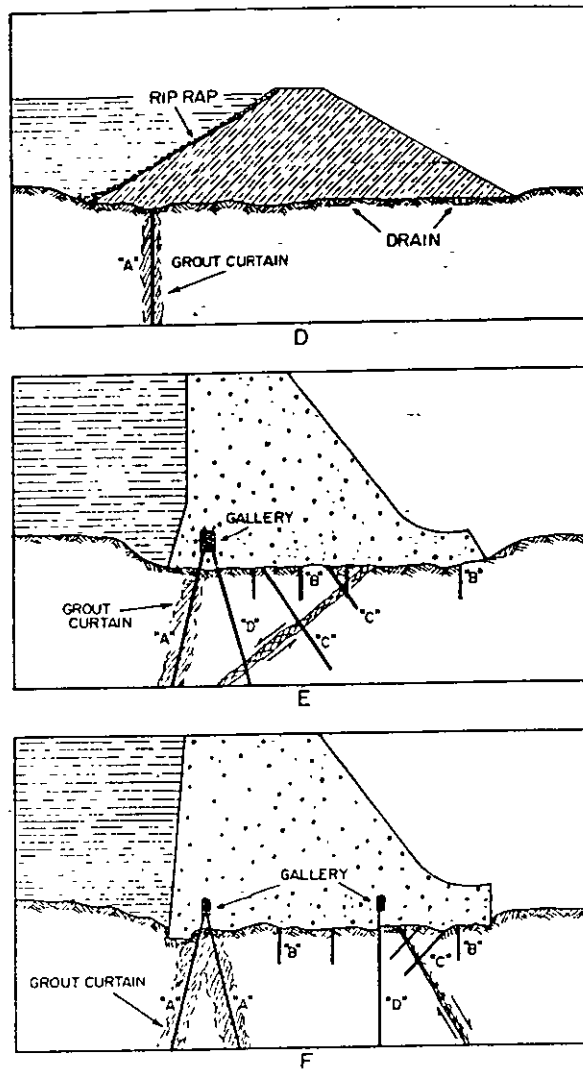

Fig. 10-2. (continuación)
 Algunas secciones de presas con la roca de cimentación mostrando las localizaciones de los barrenos perforados para el tratamiento de la cimentación.— Véase discusión en el texto para explicaciones de las designaciones de las perforaciones.—

- D.— Presa de tierra.
- E.— Presa de concreto gravedad con perforaciones "C" intersectando una zona de falla.
- F.— Presa de concreto gravedad con pantalla doble y perforaciones "C" intersectando una zona de falla permeable.—

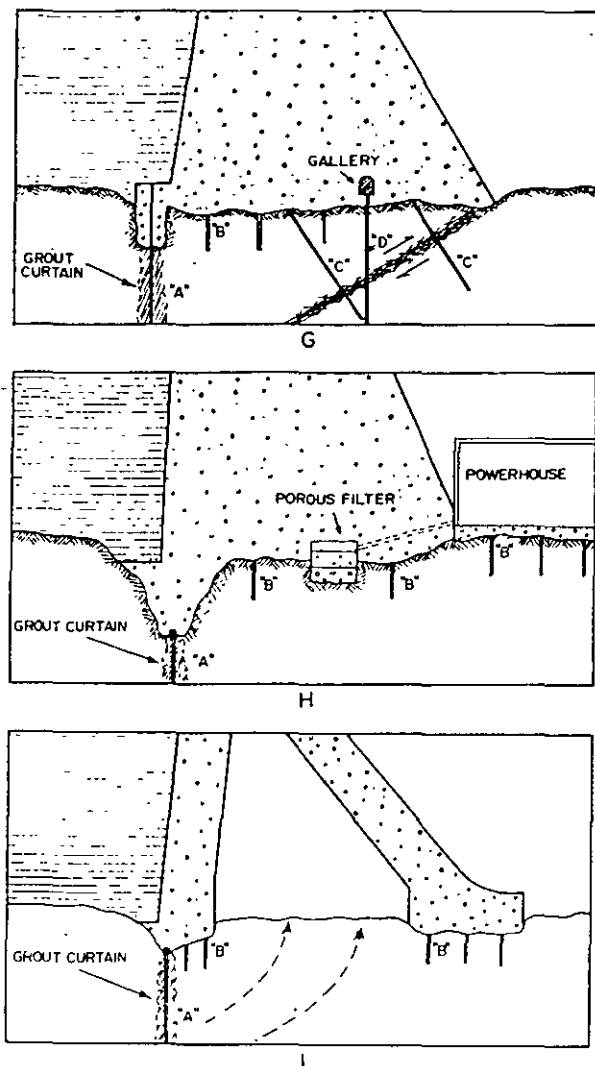

Fig. 10-2. (continuación)
 Algunas secciones de presas con la roca de cimentación mostrando las localizaciones de los barrenos perforados para el tratamiento de la cimentación.- Véase discusión en el texto para explicaciones de las designaciones de las perforaciones.-

- G.- Presa de concreto gravedad con perforaciones "C" para propósitos especiales.
- H.- Presa de concreto gravedad con filtro poroso para coleccionar el agua de filtraciones.
- I.- Presa de concreto gravedad hueca (aligerada), las flechas indican posible flujo de filtraciones pasando la pantalla de inyección

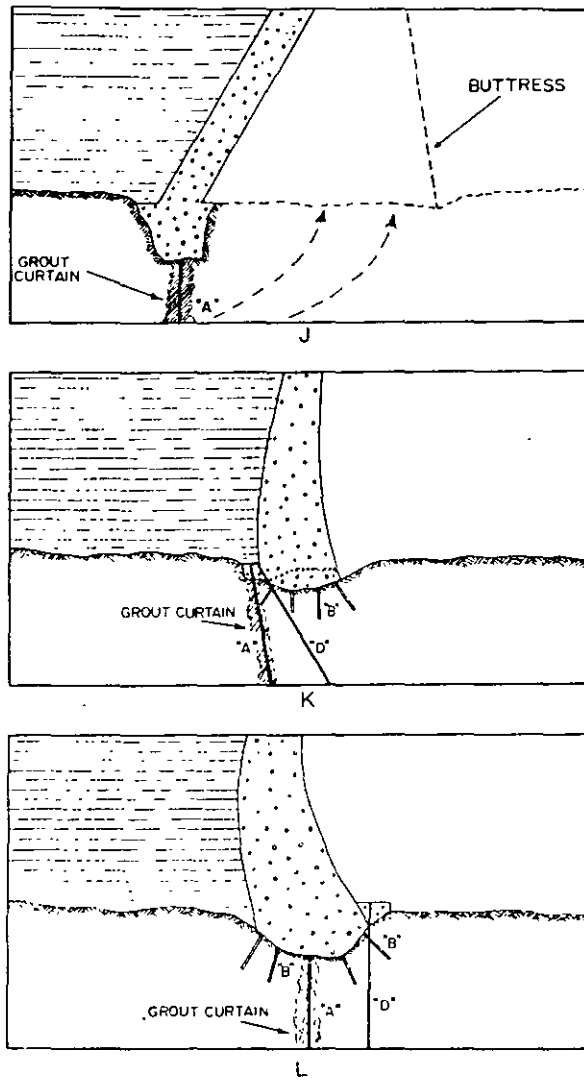

Fig. 10-2. (concluye)

Algunas secciones de presas con la roca de cimentación mostrando las localizaciones de los barrenos perforados para el tratamiento de la cimentación.- Véase discusión en el texto para explicaciones de las designaciones de las perforaciones.-

J.- Presa de concreto de contrafuertes. Las flechas indican posible paso de filtraciones a través de la pantalla inyectada.-

K.- Presa de concreto en arco.-

L.- Presa de concreto en arco.-

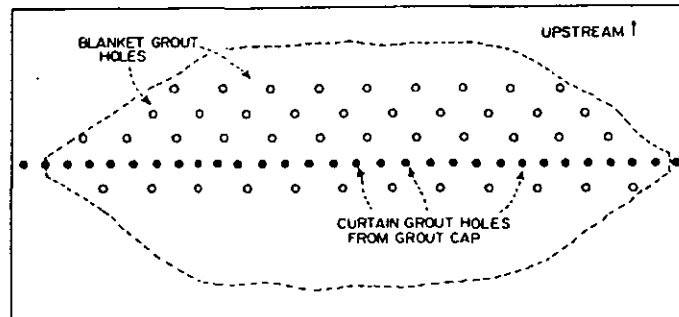

A

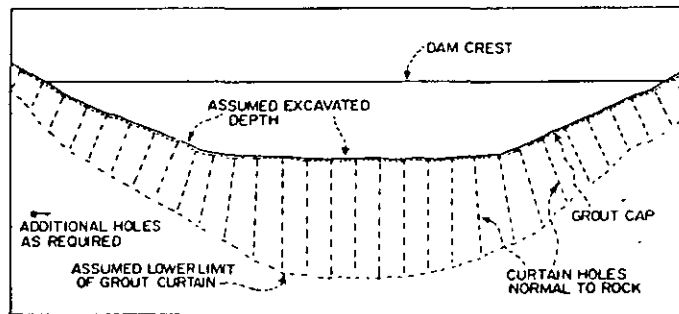

B

Fig. 10-3 Localización esquemática de la plantilla de las perforaciones, de tapete y pantalla en el lecho de roca de una presa de tierra de tamaño mediano

A.- Planta

B.- Perfil mostrando la profundidad de fórmula de las perforaciones de pantalla.

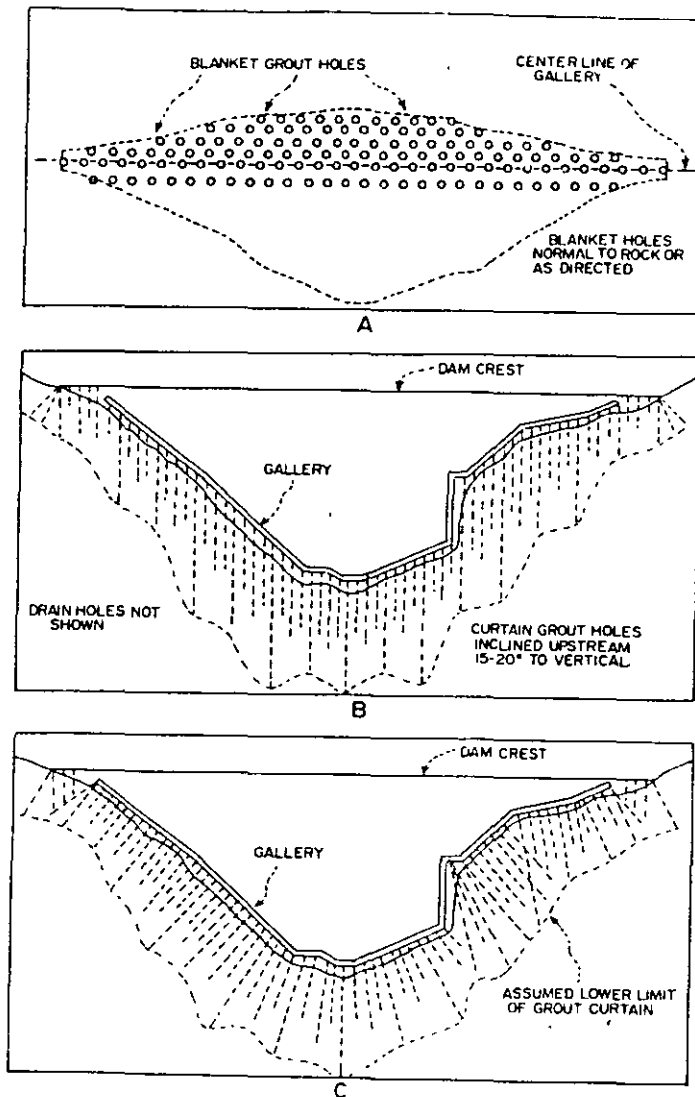
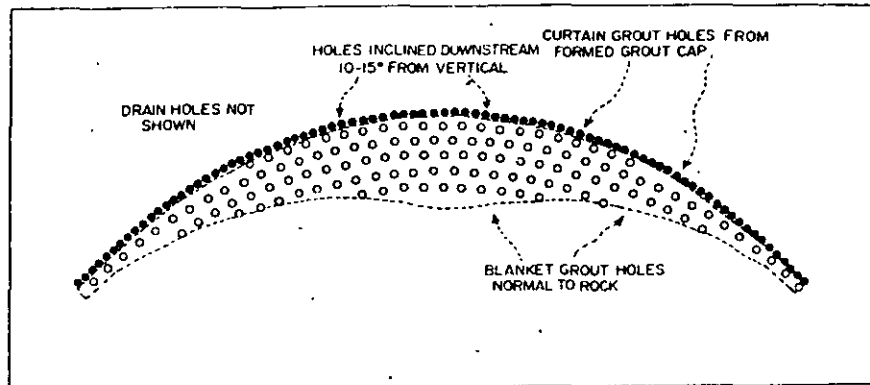
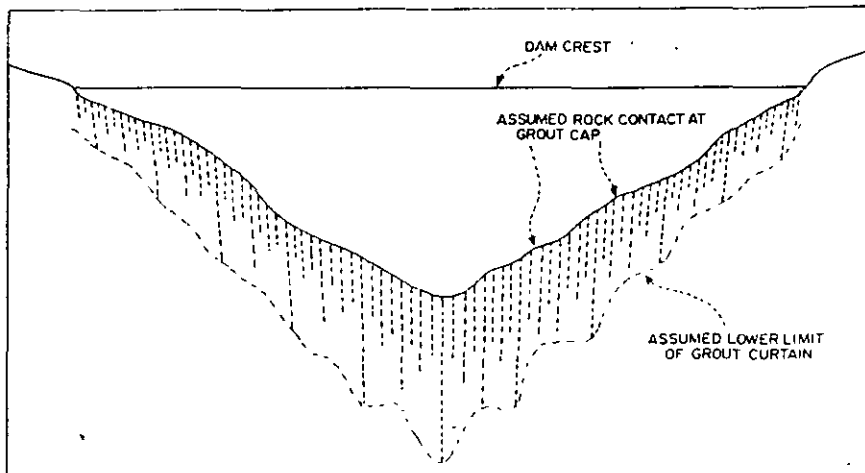

Fig. 10-4 Localización esquemática de la plantilla de las perforaciones de tapete y pantalla en la cimentación de una presa de concreto gravedad. Las perforaciones para la pantalla se hacen desde una galería dentro de la presa.

- A.- Planta mostrando la localización de las perforaciones de tapete en el lecho de roca.
- B.- Perfil mostrando la localización de las perforaciones de pantalla (plantilla principal)
- C.- Perfil mostrando el plan alternativo de inyección desde galerías. Note el abanicamiento de las perforaciones con la profundidad, generalmente no es deseable en roca profundamente fracturada.



A



B

Fig 10-5 Localización esquemática de la pantalla de las perforaciones de tapete y pantalla en la roca de cimentación de una presa de arco delgada.

A.- Planta

B.- Proyección en un plano vertical pasando a través de los empotramientos. No se muestran las perforaciones de tapete.

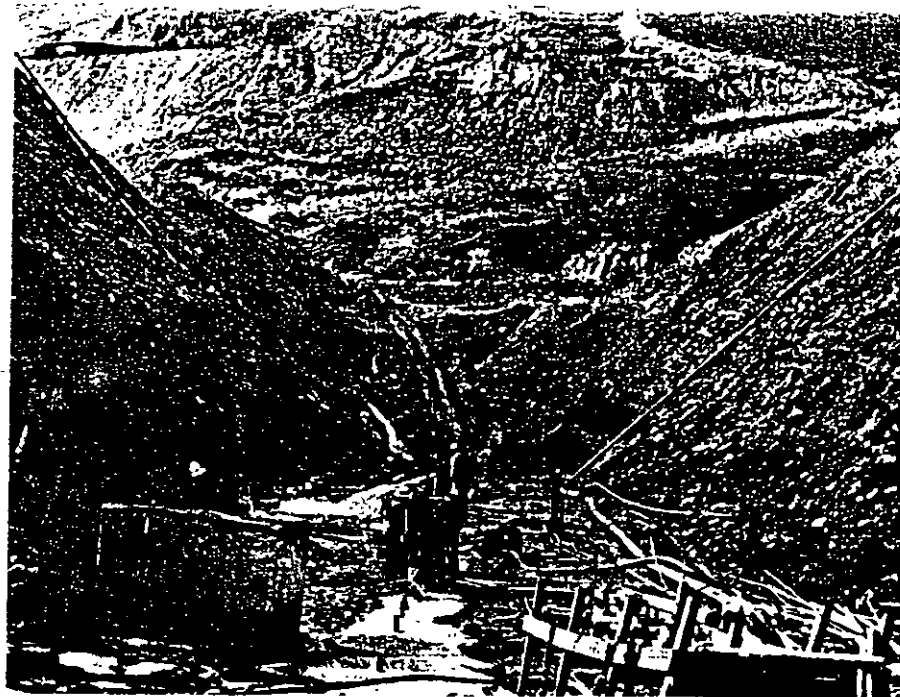

Fig. 10-6 Dentellón en el fondo de la trinchera excavada en depósitos de grava para apoyo de la pantalla de inyección, en la Presa Dillón Colorado.- (Foto cortesía de la Junta del Comisionado del agua de Denver)

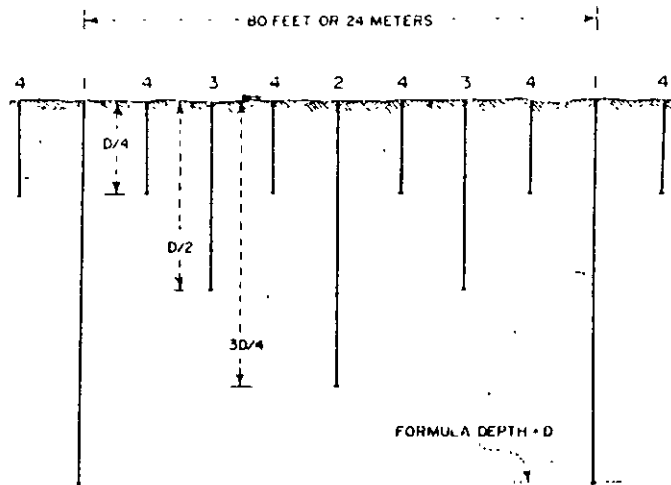

Fig. 10-7 Plantilla convencional cerrada de perforación e inyectado de pantalla. Los números indican la secuencia de perforación e inyectado.-

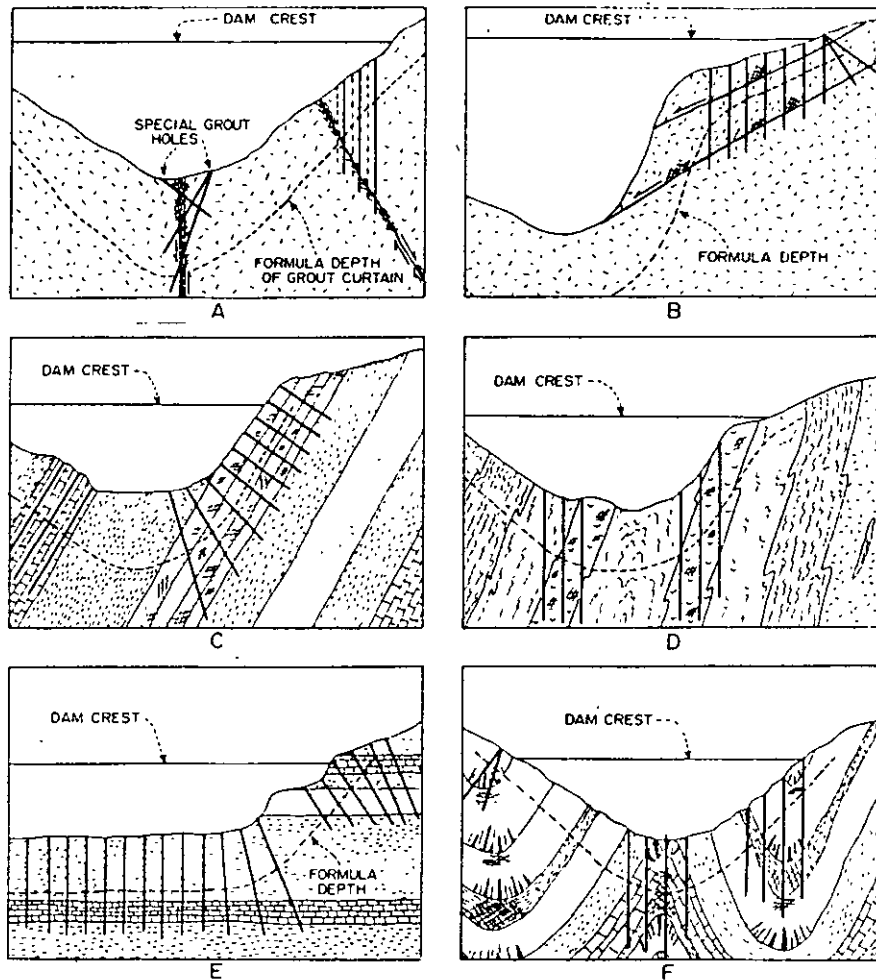

Fig. 10-8 Perforaciones de pantalla con profundidades y altitudes determinadas por las condiciones de la geología; subterráneas. La línea punteada indica la máxima profundidad de la pantalla tal como serían calculadas por una fórmula sin considerar las características geológicas.

- A.- Barrénos inclinados especiales son perforados para intersectar una zona amplia quebrada a lo largo de una falla escarpada, y plantilla de perforaciones profundizadas para intersectar otras fallas en un empotramiento.
- B.- Plantilla de perforaciones que son profundizadas para intersectar zonas permeables a lo largo de una falla de deslizamiento por gravedad en un cañón de paredes escarpadas en rocas cristalinas.
- C.- Plantilla de perforaciones que son profundizadas en una capa de calizas y que se extienden para cruzar una capa inclinada de arenisca frágil fracturada.
- C.- Plantilla de perforaciones que son profundizadas en

una capa de calizas y que se extienden para cruzar una capa inclinada de arenisca frágil fracturada.

- D.- Perforaciones de inyectado que son profundizadas para penetrar capas fracturadas de cuarcita frágil en una secuencia metamórfica conteniendo esquistos y gneise
- E.- Perforaciones de inyectado aumentadas más alla de la profundidad de fórmula para probar la permeabilidad en calizas de disolución.
- F.- Perforaciones profundas de inyectado para indagar zonas muy fracturadas asociadas con plegamientos apretados en rocas sedimentarias.-

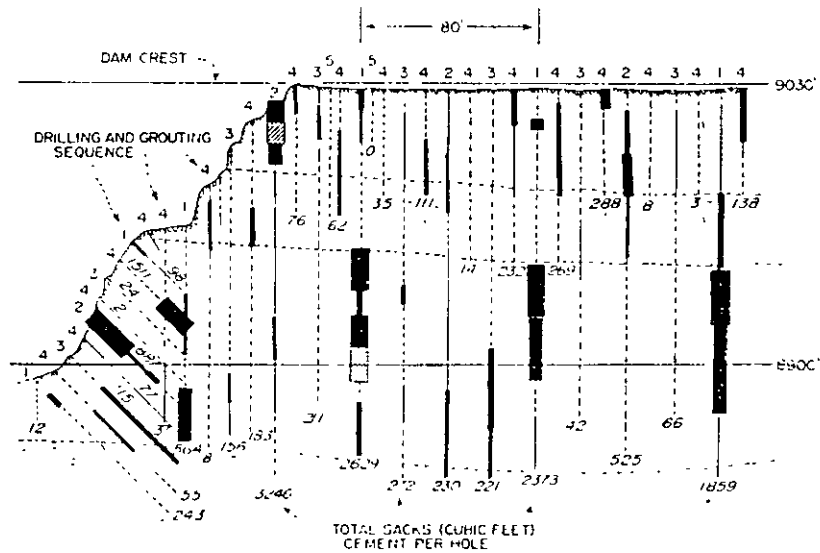

Fig. 10-9 Pantalla de inyección a lo largo de un segmento de la cimentación y empotramiento de la presa Dillón Colorado, una presa de terraplen descansando en rocas sedimentarias y contruida por la Junta del Comisionado del agua de Denver. Las capas de lutitas se indican con símbolos apropiados. Rocas en capas arriba y abajo de la lutita consisten principalmente de areniscas frágiles y cuarcitas sedimentarias (véase fig 10-10). Los anchos de las barras son proporcionales a la toma de lechada entre los obturadores fijados.-



Fig. 10-10 Fracturamiento, cerrado en cuarcita muy permeable expuesta en la excavación de la trinchera para inyecciones, durante la construcción de la Presa Dillón, Colorado. (Foto cortesía de la Junta del Comisionado del agua de Denver)

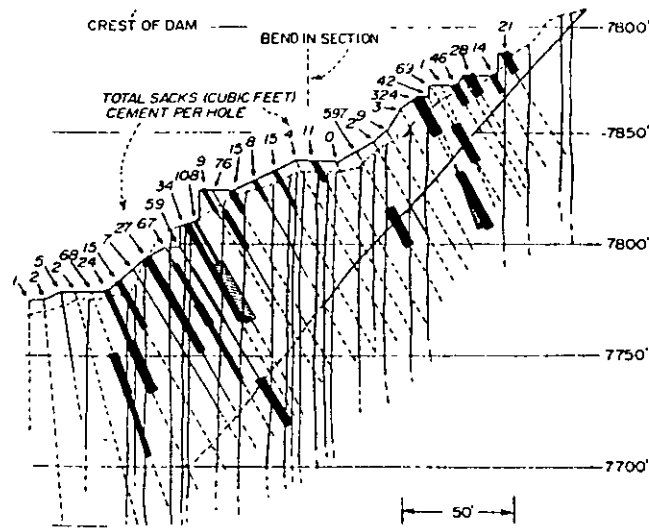

Fig. 10-11. Una porción de la pantalla de inyección de la presa Williams Fork, Colorado, una presa de arco delgado descansando en rocas cristalinas estrechamente cizalladas. El ancho de las barras son proporcionales a la toma de lechada entre los obturadores que se fijan. Proyección sobre un plano vertical. Mirando hacia aguas abajo. La presa fué construida por la Junta de Denver del Comisionado del Agua.-

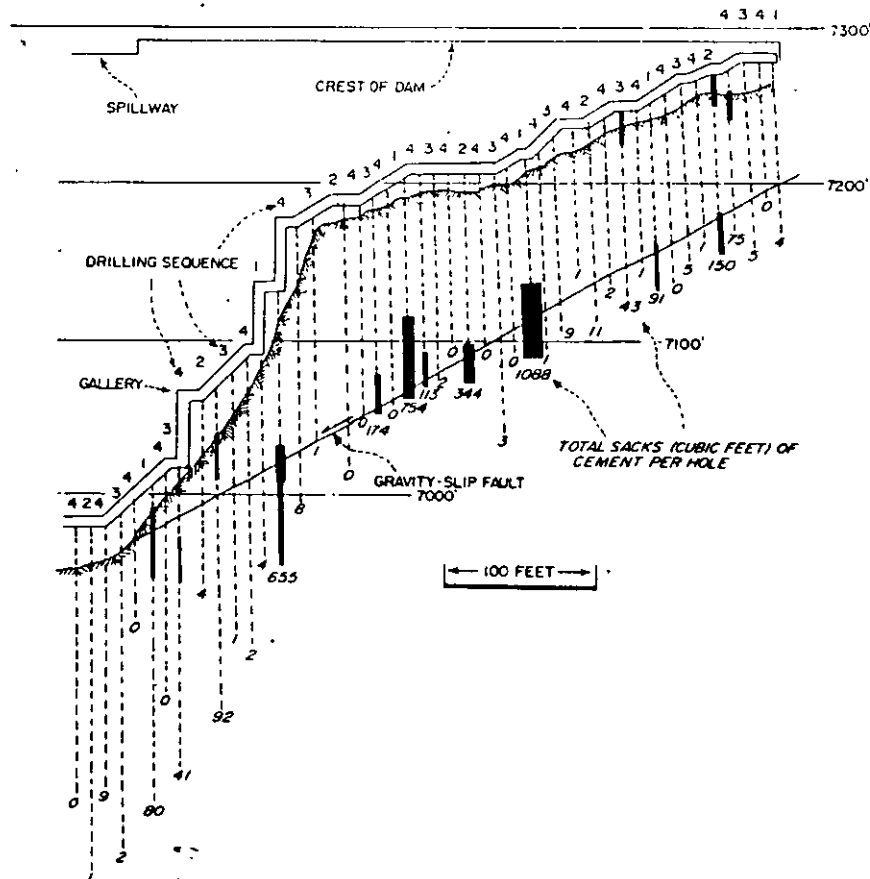

Fig. 10-12. Una porción de la pantalla de inyección de la presa Gross, Colorado. Note la penetración extensiva de lechada en una falla de deslizamiento por gravedad. La presa fué construida por la Junta en Denver del 85

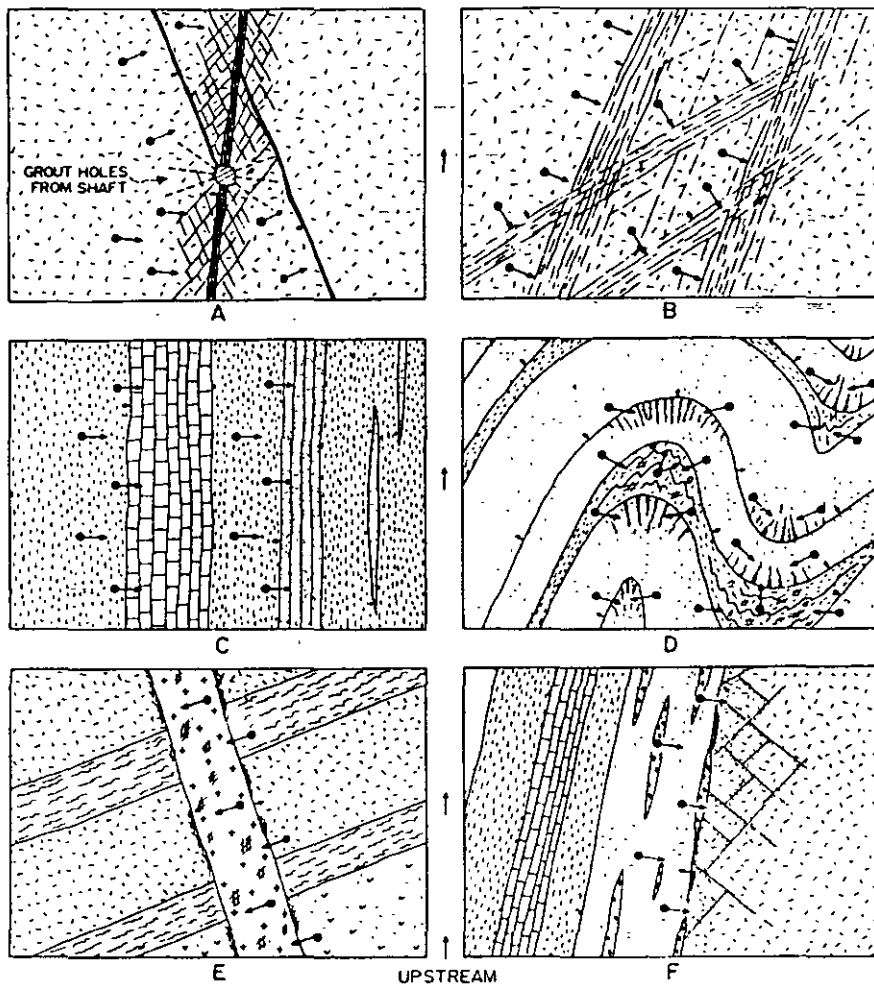

Fig. 10-13. Perforaciones extras para propósitos especiales de inyección (perf. "C") en la roca de cimentación.

- A.- Perforaciones inclinadas desde la superficie y perforaciones horizontales desde una lumbrera intersectando fallas profundas y fracturas a profundidad.
- B.- Barrenos que son perforados para intersectar zonas laminadas proyectadas hacia abajo en rocas cristalinas frágiles.
- C.- Estratos inclinados sedimentarios presentan potenciales filtraciones bajo una presa. Perforaciones inclinadas son barrenadas para intersectar unos estratos de caliza y capas frágiles de arenisca.
- D.- Plantilla de perforaciones inclinadas hacia el interior de juntas y roca cizallada y a través de plegamientos en rocas sedimentarias.
- E.- Perforaciones para intersectar juntas cercanas de un dique ígneo a profundidad.
- F.- Perforaciones "extras" para intersectar una zona de juntas intemperizadas en rocas cristalinas abajo de una discordancia.

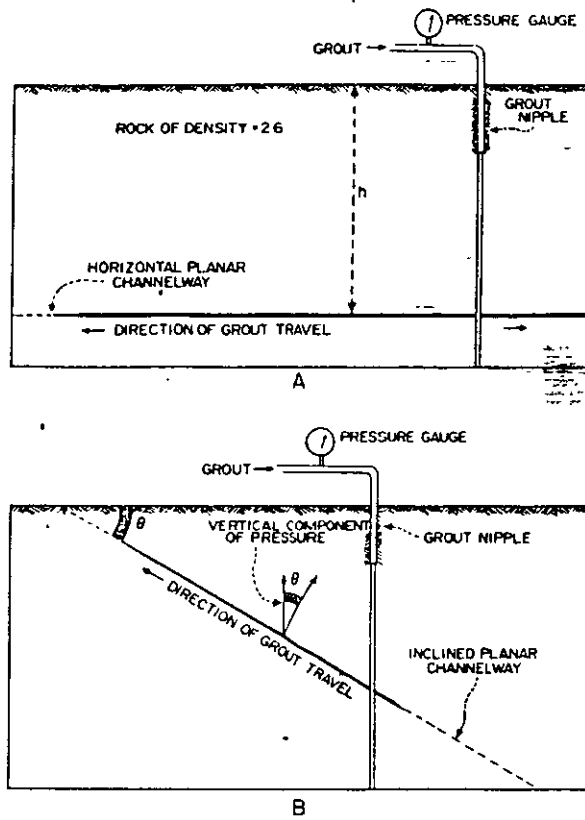

Fig. 10-14. Vías planas de circulación de lechada horizontal e inclinadamente (véase discusión en el texto)

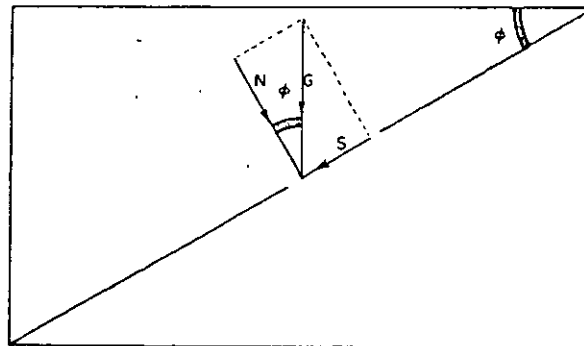

Fig. 10-15. Diagrama de fuerzas para determinar el coeficiente de fricción estática.

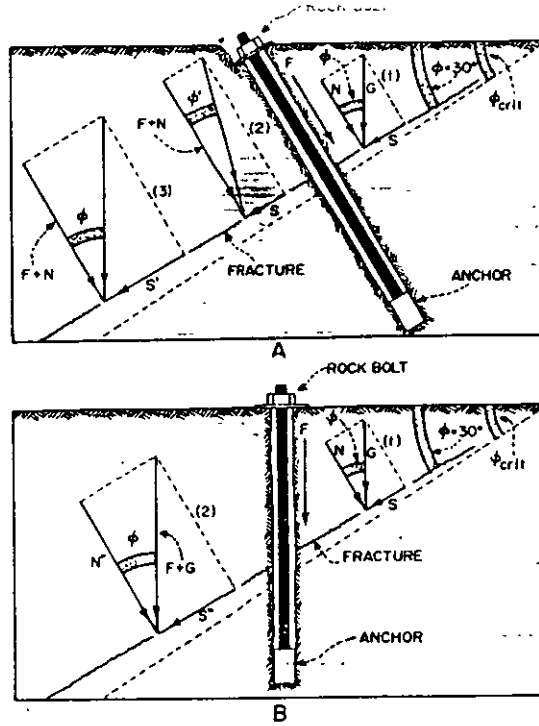

Fig.10-16. Rock bolts intersecting a fracture which may localize shear dislocation. See text discussion.

A. Rock bolt is normal to fracture.

B. Rock bolt is vertical and creates a force parallel to the force of gravity.

Fig. 10-16. Ancla de varilla intersectando una fractura la cual puede que localice una dislocación por cortante.

A.- Ancla normal a la fractura.

B.- Ancla vertical y crea una fuerza paralela a la fuerza de gravedad.

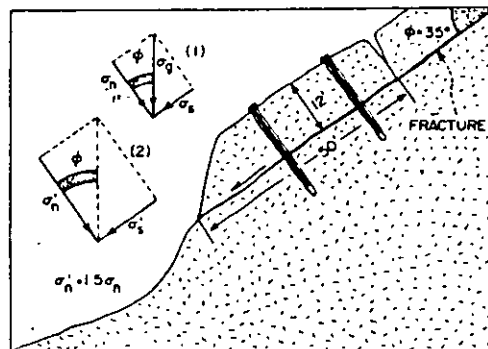

Fig.10-17. Rock slab resting nearly at angle of repose on a fracture. See text discussion.

Fig. 10-17. Losa de roca reposando muy cerca con el ángulo de reposo sobre una fractura. (Véase discusión en el texto).

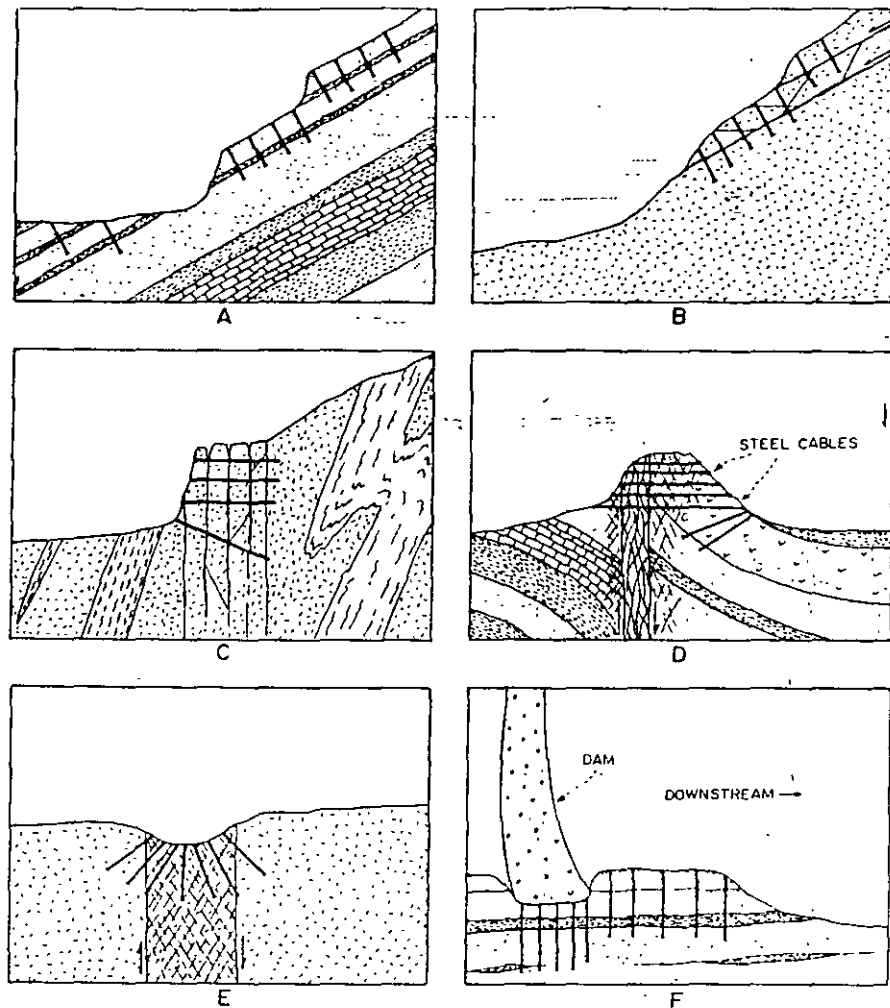
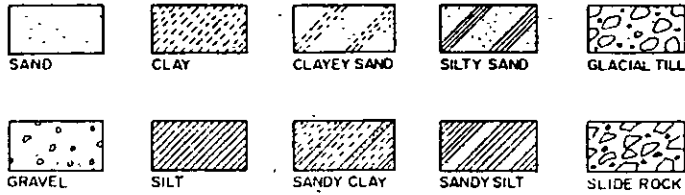

Fig. 10-18. Reforzamiento de masas de roca por anclas de tensión o cables de acero.

- A.- Un talud potencialmente inestable en rocas inclinadas sedimentarias estabilizadas con anclas.
- B.- Bloques de roca cristalina arriba de fallas inclinadas hacia el fondo del valle sujetadas por anclas de tensión.
- C.- Anclas usadas para aumentar la resistencia a una masa de roca cristalina intersectada por cortaduras verticales. Inyectando después del tensionado de las anclas será muy útil el propósito.
- D.- Una zona resquebrajada a lo largo de una zona de falla es estabilizada por cables de acero - e inyectado antes y después de tensionar los cables.
- E.- Anclas instaladas en una zona muy fracturada en una cimentación. Es recomendado la inyección antes y después de la instalación de las anclas.
- F.- Instalación de anclas o cables de alta resistencia para reducir peligros de una dislocación posible a lo largo de capas horizontales de lutita cuando el vaso se llene.-

UNCONSOLIDATED DEPOSITS



CONSOLIDATED DEPOSITS

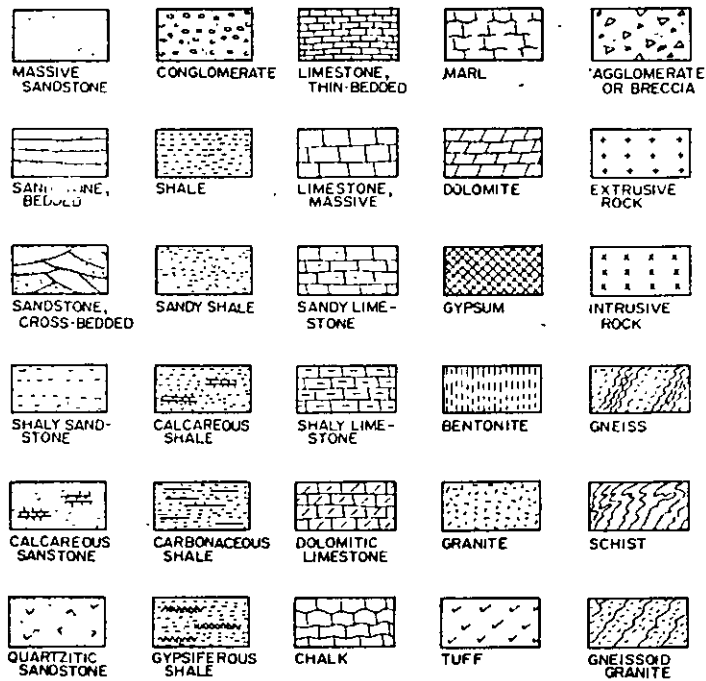

Fig.9-6. Graphic symbols for plotting logs of unconsolidated and consolidated (rock) materials.

CUADRO 26-2
CARACTERÍSTICAS Y POSIBILIDADES APROXIMADAS DE LOS PRINCIPALES MORTEROS DE INYECCIÓN

		<i>Tipo de mortero</i>	<i>Resistencia a la rotura¹</i>	<i>Precio relativo por m³.²</i>	<i>Campo de utilización³</i>	<i>Forma de efectuar la inyección.</i>
SUSPENSIONES	Morteros inestables	— Suspensiones de cemento en el agua (+arena) C/A 1/10 a 1/1 o 1,5/1	Comparables al hormigón	4,2	Figuras de macizos rocosos o fábricas	Cantidades no limitadas pero obteniendo presión de rechazo
	Morteros estables	— Cementos y morteros activados { Prépakt Thermocol Colcreete	Comparables al hormigón		Relleno de grandes huecos	Cantidades limitadas
	(decantación de unas centésimas)	— Cemento-arcilla (+arena) — Arcilla tratada	1 a 50 kg/cm ² < 1 g/cm ²	1 1,1	Figuras anchas + arenas y gravas $K > 5 \cdot 10^{-4}$ m/s	
Morteros	Geles duros	— Silicato de sodio { +CaCl ₂ + Acetato de etilo — Lignosulfito + bicromato	10-20 kg/cm ² (mortero 40 kg/cm ²)	10,7 11	$K > 10^{-4}$ m/s	— Inyección en 2 tiempos — Mortero único
			300 g/cm ² (mortero 4-5 kg/cm ²)	6,5 a 8	$K > 5 \cdot 10^{-5}$ m/s	
LIQUIDOS	Geles plásticos	— Silicato de sodio + reactivo — Bentonita defloculada	— 50 g/cm ³	2 a 4	$K > 10^{-5}$ m/s	Cantidades limitadas
			— 10-20 g/cm ²	1,8	$K > 10^{-4}$ m/s	
(Productos químicos)	Resinas orgánicas	— AM 9 — Resorcina-formol — Urea-formol (mortero ácido)	— < 1 kg/cm ²	50 a 130	Para inyecciones corrientes	
			— 10 g/cm ² a 100 kg/cm ² — 20 a 100 kg/cm ²	10 a 40	$K > 10^{-6}$ m/s	
	Aglomerantes hidro-carbonados	— Polímeros pre-condensados (époxy) — Emulsiones de betún { +silicato +resorcina	Comp. 1000 kg/cm ² Tract. 300 kg/cm ²	150-500	Pegado de fisuras de hormigón	
			— 100 g/cm ³ — (mortero 10 kg/cm ²)	6 12	$K > 10^{-5}$ m/s	
		— Betún caliente	Líquidos muy viscosos		Circulaciones de agua importantes	

¹ Salvo indicaciones contrarias, estas resistencias son las del mortero puro después del fraguado o endurecimiento (para valores muy pequeños, esta resistencia se tomó igual al doble de la rigidez).

² Se trata del precio de compra de los productos necesarios para el relleno de 1 m³ de huecos. Ni el transporte ni el tiempo de inyección pueden variar bastante de un mortero a otro, han sido tenidos en cuenta. Cuando hay dos valores, el más elevado corresponde a las resistencias máximas. La base 1 es relativa a 300 kg de arcilla y 200 kg de cemento por 1 m³. Para la suspensión de cemento se admite que el depósito tiene una densidad seca de 1,5.

³ Las permeabilidades K indicadas son las de los suelos sueltos susceptibles de ser impregnadas por el mortero. Cuando la rigidez de éste es débil no es necesario inyectar en suelos muy permeables. (La impregnación no es el único método de inyección satisfactorio.)



Foto I. Presa las Adjuntas Tamps.
Vista aerea.- Trabajos de la primera etapa de construcción de la cortina.- Recinto protegido con una ataguía sobre la margen izquierda.



Foto 2. P.Las Adjuntas Tamps.
Excavación general de limpia de la ladera derecha.- Nótese el espesor de material de talud (escombro de calize) de unos 4m. aproximadamente normal al talud de la ladera.-

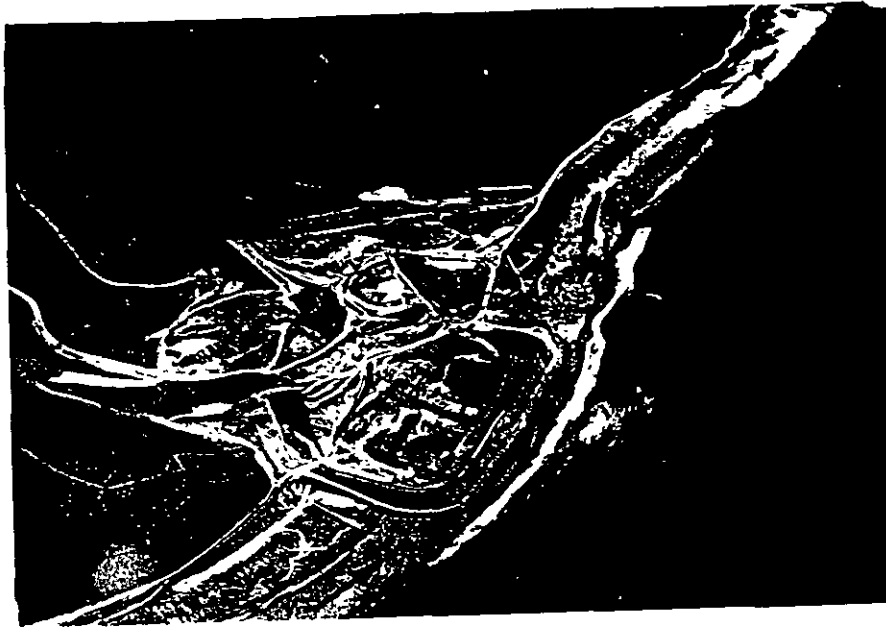

Foto 3-4. Obra presa Las Adjuntas Tamps. Marzo de 1968
Excavación de Limpia en la margen derecha.- Se aprecia
la formación Agua Nueva de la caliza.-
Aquí aproximadamente a la elevación 148 de la Corona.-
El espesor de escombros es de unos 4 metros aproximadamen-
te normal al talud del cerro.



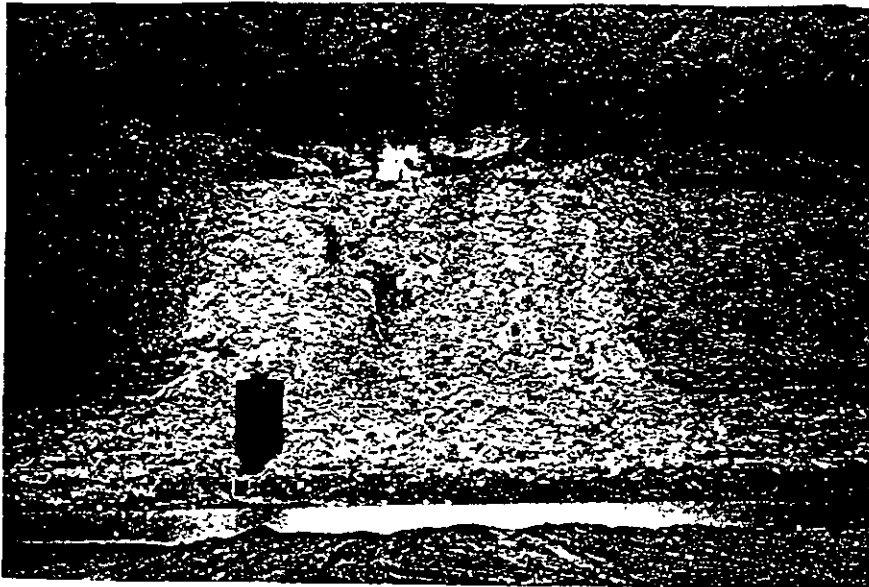
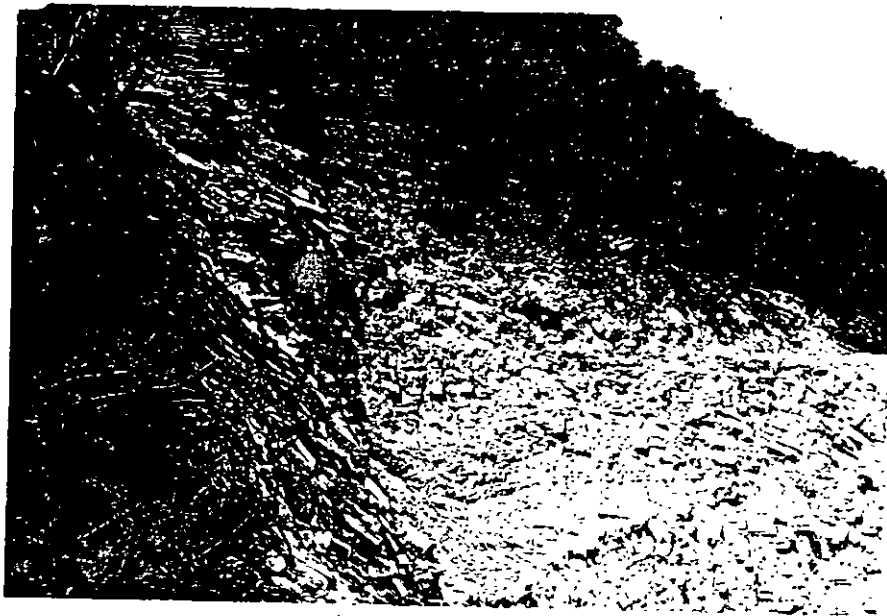

Foto 5. Obra Presa Las Adjuntas Tamps. Octubre de 1968.
CORTINA.- Detalle de la trinchera del material impermeable entre las Est. 0+330 (donde termina la arcilla) y 0+350 (en donde se encuentra la perforadora Stenuik) y entre las cuales se formó un segundo abanico entre las elevaciones II3 a I20 formado con diferentes planos que se hicieron con precorte para empotrar el corazón impermeable



Foto 6. Presa Las Adjuntas Tamps.
Trinchera para el material impermeable en la ladera izquierda entre las estaciones 0+330 a 0+350 y entre las elevaciones II3 a I20. Los taludes se formaron con precorte.

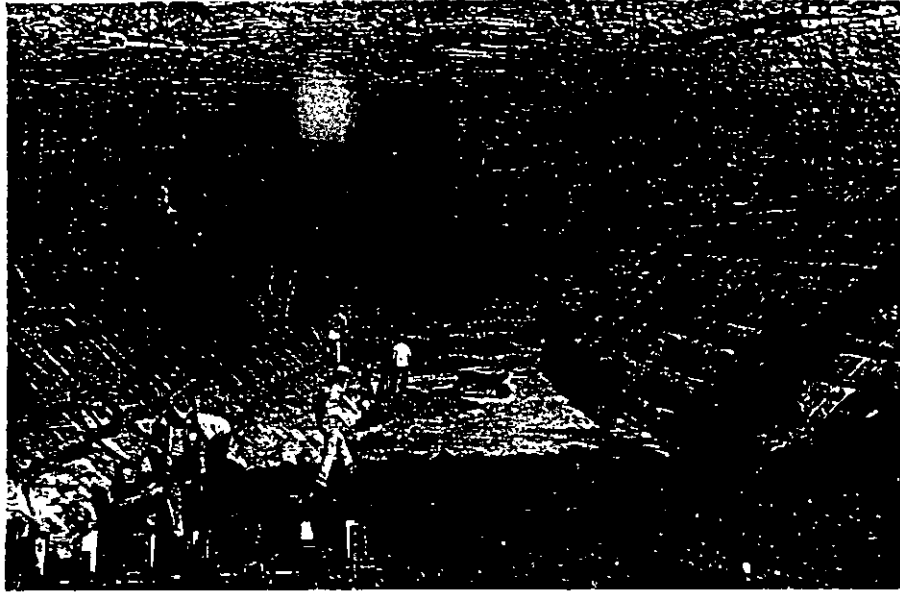

Foto 7. Presa Las Adjuntas Tamps. Febrero 14 de 1969.
Aspecto que presentó la roca de cimentación en la zona del material impermeable en la parte más profunda de la cimentación.- Aquí un estrato de Lutita negra Lutificada con las figuras caprichosas que le labró el agua del río cuando éste pasaba sobre estos estratos, pues actualmente había sobre ellos un fuerte espesor de relleno de acarreo y escombros de la misma formación.



Foto 8. Presa Las Adjuntas Tamps. Febrero 18 de 1969.
Aspecto que presentó la caliza al quitar el material de acarreo en el lecho del río, después de lavarla y soplearla en la zona para el desplante del material impermeable.- Por el eje se excavó además una trinchera de 3m. de profundidad y 6m. de plantilla con taludes 1:1.- El espesor del material de acarreo que se quitó fue de 12m.
05



Foto 9-10. Presa Las Adjuntas Tamps. Febrero de 1969
Colocando el material impermeable en la trinchera en
la II Etapa de la Cortina. Zona de la Antigua Ataguía
Provisional y lugar del cauce original.-
Esta parte corresponde a la parte más profunda de la
cimentación aproximadamente en la Est. 0+140.





Foto II. Presa Las Adjuntas Tamps.
CORTINA.- Construcción de la I Etapa.- En primer plano
continuación de la Trinchera, Labrada con precortes, -
sobre la ladera izquierda.-

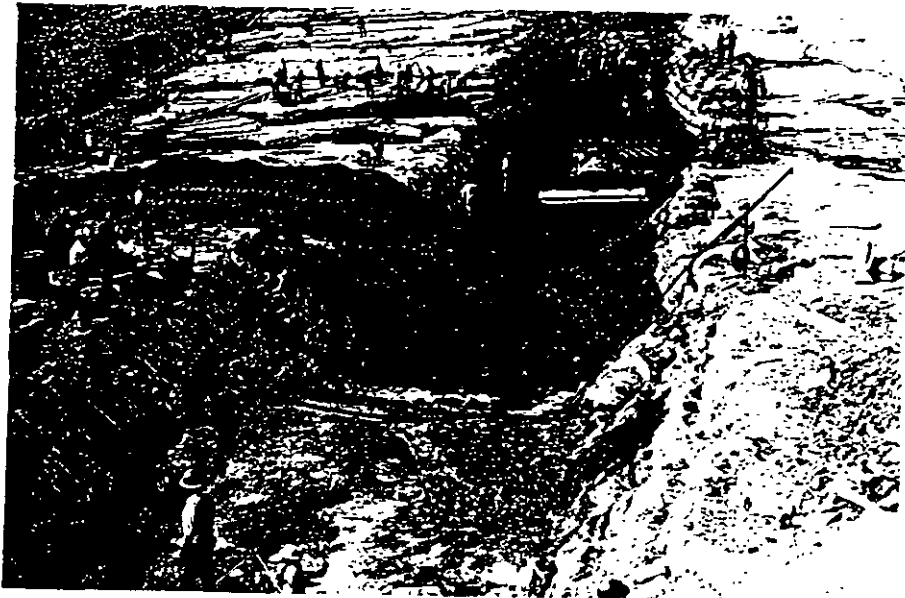

Foto 12. Presa Las Adjuntas Tamps. Octubre de 1968.
CORTINA.- Detalle de la trinchera del material imper-
meable a la altura de la estación 0+330.-
Nótese la compactación especial con bailarina en la
orilla del talud, conforme se va haciendo el relleno.-

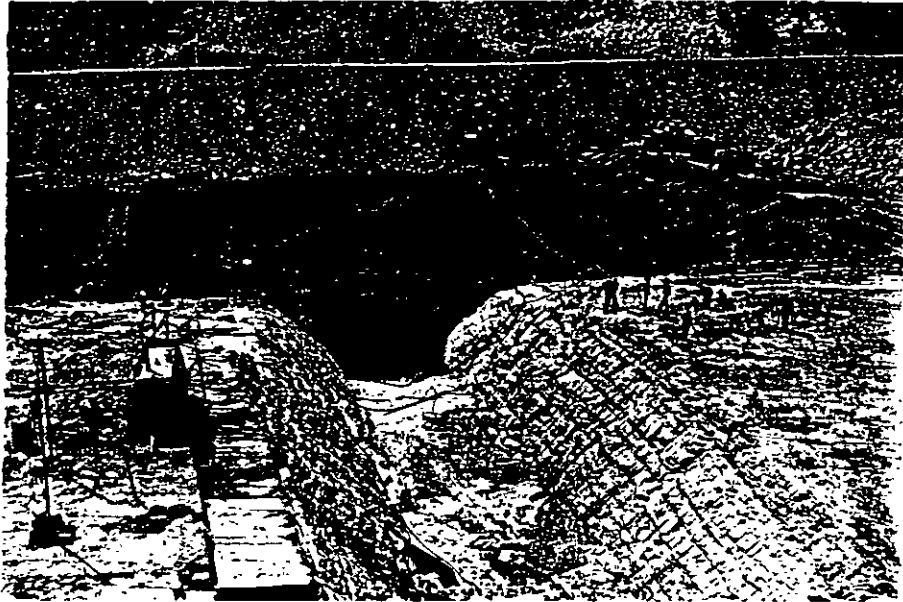

Foto I3. Presa Las Adjuntas Tamps.
Retiro de una piedra grande con el traxcavo.- Esta piedra presentaba sus contactos muy alterados y fué necesario removerla (sin el uso de explosivo)

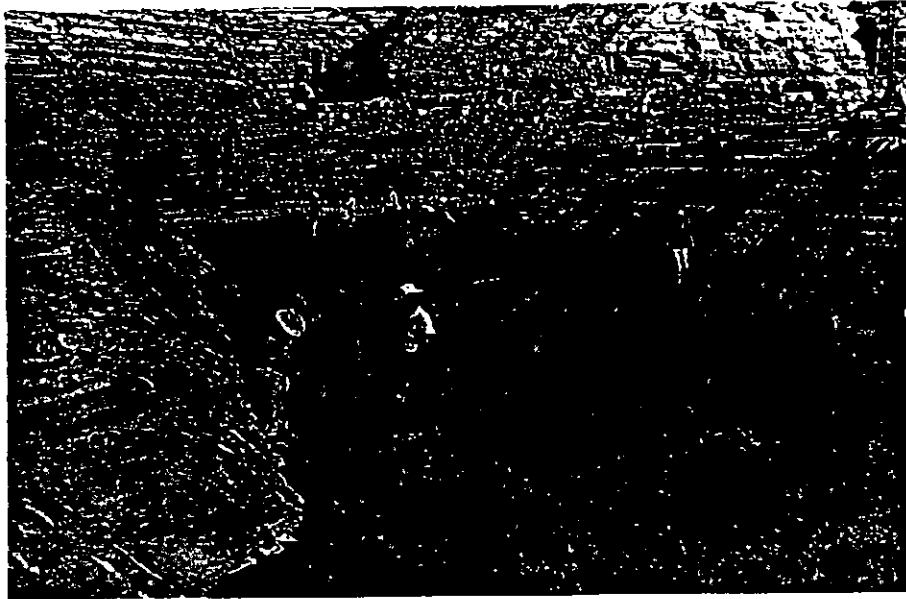

Foto I4. Presa Las Adjuntas Tamps.
Hueco en forma de olla (mqrmita) labrado por el trabajo erosivo del agua que aparecieron al remover el material de acarreo en el fondo del río en la zona del material impermeable.



Foto I5. Presa Las Adjuntas Tamps.
Excavación general de limpia de la ladera derecha.-



Foto I6. Presa Las Adjuntas Tamps.
Vista panorámica de la cortina a la izquierda, construcción de la I Etapa, e la derecha de la foto la ladera derecha con su excavación de limpia muy adelantada.



Foto I7. Presa El Granero Chih.
Superficie de fractura por gravedad (indicada por la flecha en el empotramiento derecho, sobre las trazas del impermeable)



Foto I8. Presa El Granero Chih.
Nuevo corte que se ejecutó sobre un talud cortado muy vertical, y que fué necesario abatirlo por haber quedado inestable debido al fracturamiento de la roca.-



Foto 19. Presa Guamuchil Sin.
Limpia de "dedo" en el fondo del río, después de haber
excavado con máquinas el relleno de aluviones en el cau-
ce.-



Foto 20. Presa Guamuchil Sin.
Aspecto ya terminada la limpia de "dedo".- Se aprecia las
conformaciones del agua en la andesita del lecho de roca
(bedrock).



Foto 2I-22. Presa Guamuchil Sin.
Aspecto ya terminada la limpia de "dedo" en el cauce
del río.-
En la parte central se aprecia una perforadora de o-
ruga para los barrenos de inyección.- En la parte su-
perior derecha se ve las instalaciones para el mezcla-
do y bombeado de lechada.-





Foto 23. Sitio Cerro de Oro Oax. Agosto de 1972.
Panoramica que muestra el empotramiento izquierdo y el
cruce con el Río Sto. Domingo.



Foto 24. Sitio Cerro de Oro Oax. Agosto de 1972.
Panoramica que muestra parte de la terraza sobre la
margen derecha en donde la cortina quedará cimentada
sobre depósitos no consolidados de la formación "Tierra
Colorada"



Foto 25-26 Sitio Cerro de Oro Oax.
Excavación de exploración hecha con tractor en la terraza de "Tierra Colorada" para estudiar el comportamiento de este relleno no consolidado, constituido por arcillas fisuradas





Foto 27-28. Sitio Cerro de Oro Oax.
Un acercamiento del corte de tractor en la arcilla "Tierra Colorada", obsérvese la pobre resistencia o cohesión de la arcilla para sostenerse, debido a su macroestructura muy fisurada.- Obsérvese también bloques calizos sueltos dentro de la masa arcillosa.

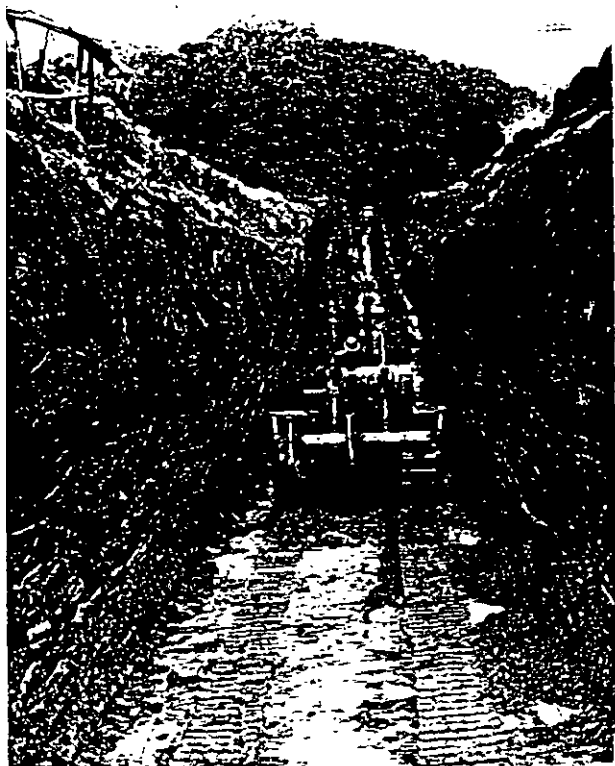

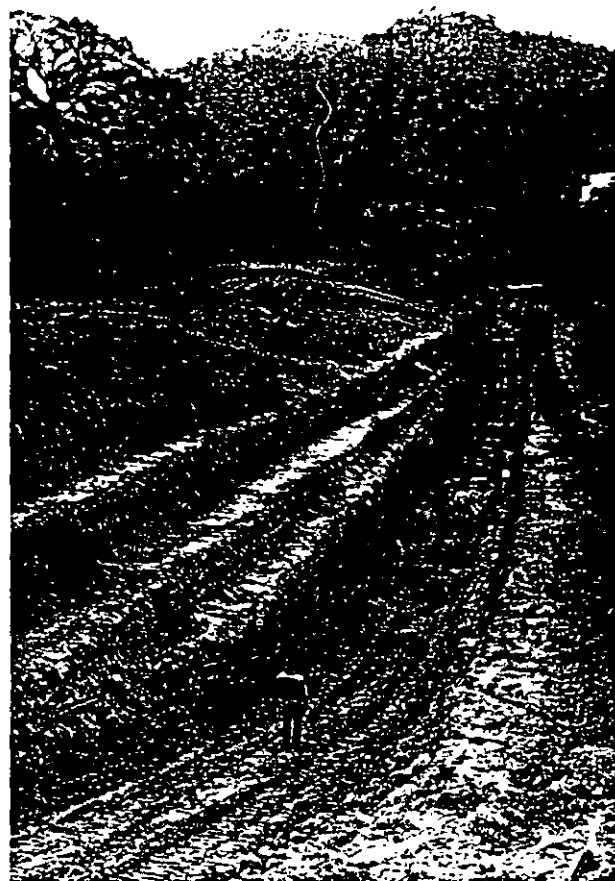

Foto 29. Sitio Cerro de Oro Oax.
Trabajos de Inyección.-
Alla izquierda máquina
de perforar Long Year
con wire-line para re-
cuperación de núcleos



Foto 30. Perforadora rotatoria
tipo T-4 sobre orugas
para perforaciones en
depósitos no consoli-
dados.-

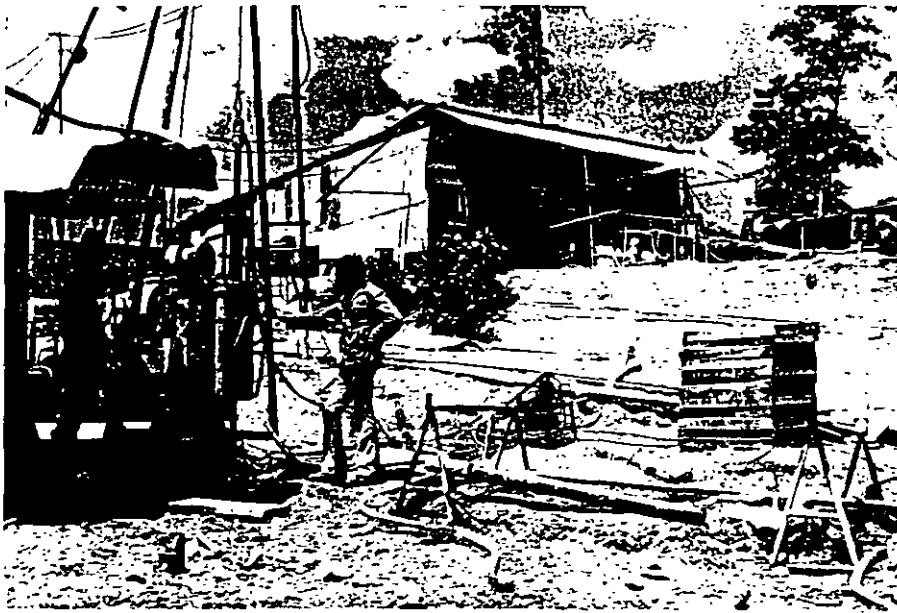

Foto 3I-32. Chicoasen Chis.
Anclaje del bloque denominado "Sud América" con 30
anclas de cable de 30m. de profundidad tipo BBRV de
100 ton. de capacidad.



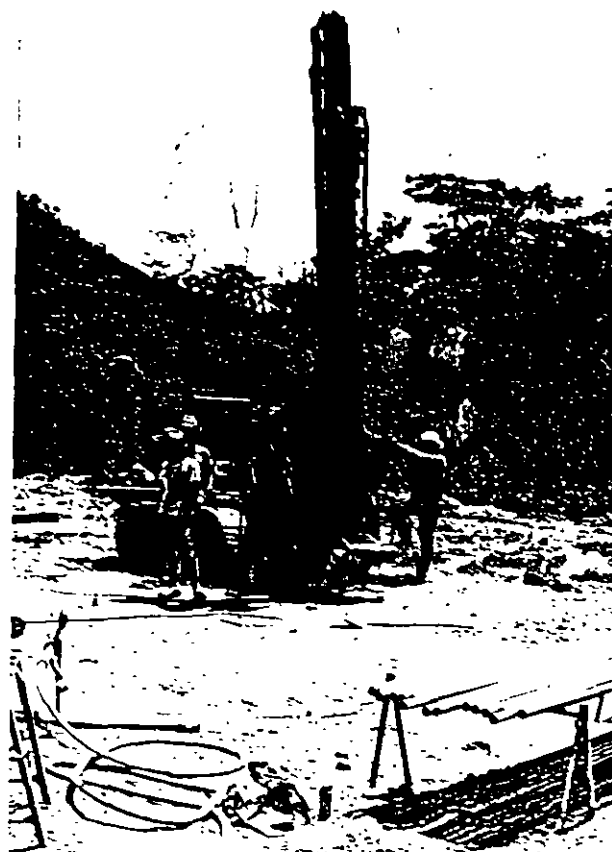

Foto 33-34. Peñascos enormes que se derrumbaron del cantil izquierdo frente a la ataguía de Aguas Abajo; motivo por el cual se ancló éste con anclas EBRV como lo muestran las fotos anteriores.





Foto 1. Sitio de la cortina Chicoasen Chis.

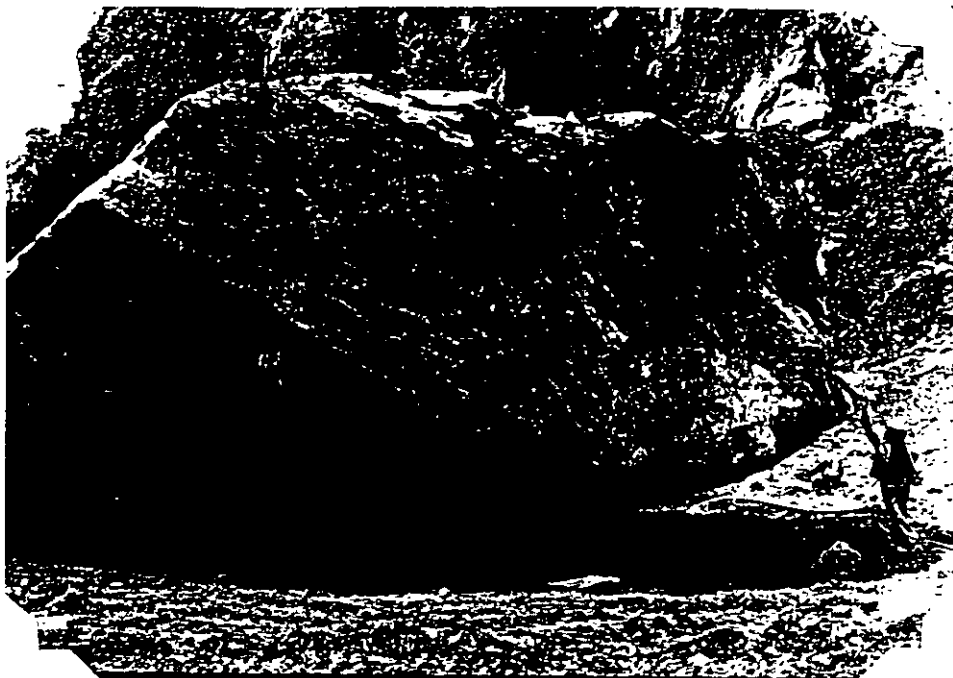

Foto 2. Túnel auxiliar de desvío.

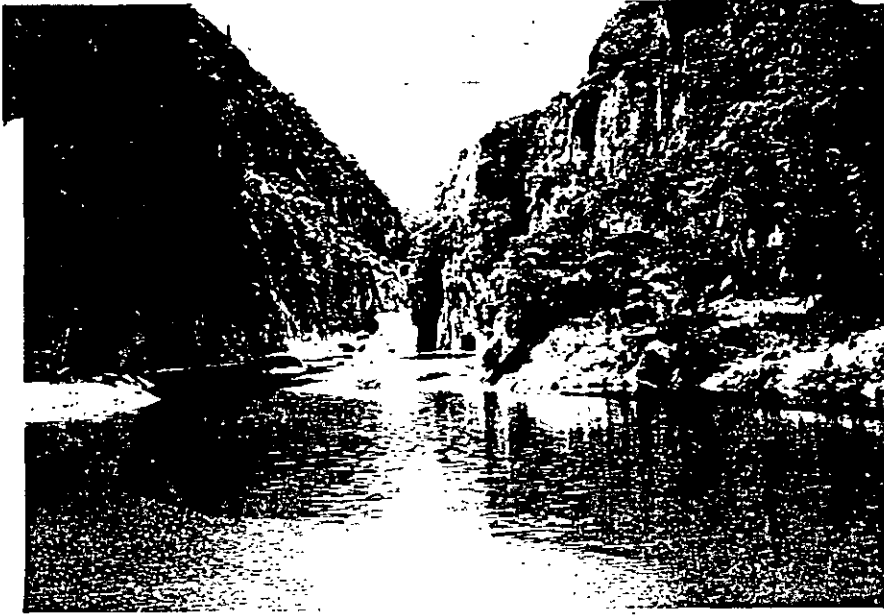

Foto 3. Ataguía de Aguas Arriba y túnel de desvío No. I.



Foto 4. Ataguía de Aguas Arriba Terminada.



Foto 5. Ataguía Aguas Abajo.



Foto 6. Se inicia la excavación de limpia - previamente habiendo bombeado el agua entre Ataguías.

SEP-29/75



Foto 7. Desechado del Recinto.



Foto 8. Balsa para las bombas.



Foto 9. Excavación de la grava-arena y limos

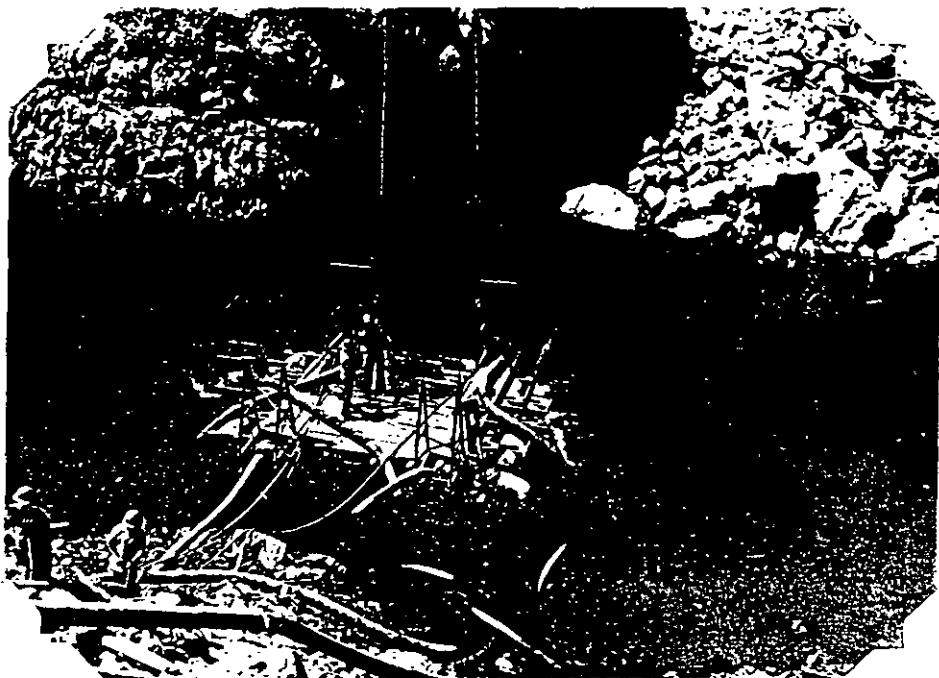

Foto 10. Lugar más profundo del cauce natural.



Foto II. Se prosiguen las excavaciones de grava-arena habiendo sacado un total de 1'600,000 de M³.



Foto I2. Aproximadamente a 25m. de profundidad se excavaron de grava-arena y limos. Conforme se avanzaba en profundidad empezaron a aparecer bloques calizos de tamaño mediano a muy grandes siendo necesario el uso de explosivos. El empleo de una retroexcavadora moderna hidráulica de 5 yds.³ de capacidad fué la clave de la excavación en la zona de bloques.



Foto I3. En esta foto se muestra como iban apareciendo en los cantiles la roca que en algún tiempo pasó el río por ella formándole marmitas,



Foto I4. Un detalle de las marmitas sobre la caliza de la Unidad II masiva.



Foto I5. Aproximadamente a 30m. de profundidad de excavación se iniciaba una garganta angosta que resultó tener 20m. de ancho en su parte superior y terminó en 4m. prácticamente formando una "V" de 25m. de altura que sumados a los 30m. anteriores dió un total de 55m. excavados.



Foto I6. Un detalle del canal angosto.



Foto I7. Dentro del canal angosto se encontraban bloques calizos de hasta 20m. de altura como el que se muestra cortado en esta fotografía un poco aguas arriba de la traza superior del material impermeable. Véase detalle en la foto a continuación.



Foto I8. Detalle de la foto anterior. Esta foto muestra que el bloque se resbaló de la parte superior del cantil acuñañocose en el canal angosto en algún tiempo muy remoto.

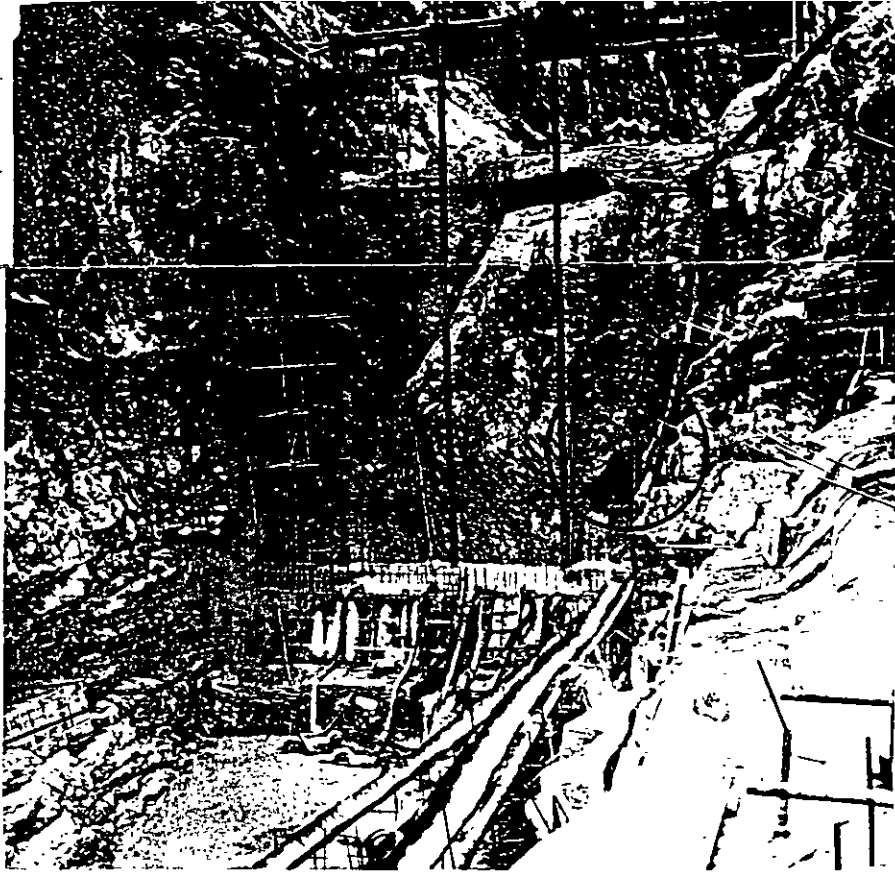

Foto I9. Otro detalle de la foto anterior donde se aprecia el bloque y rellenos más pequeños arriba de éste.

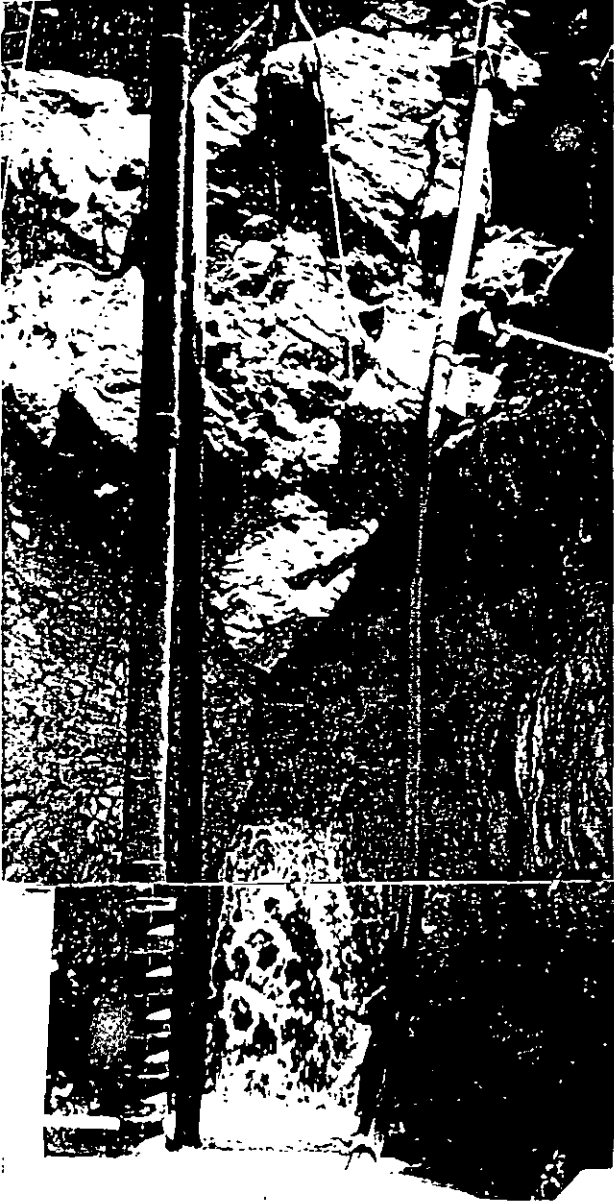

Foto 20. Al pie de la piedra grande se construyó el círculo más profundo a guisa de arribe.

Foto 21. Detalle del relleno entre los bloques grandes, gravas, arenas y lodos de color verde.





Foto 22. Remoción a mano de estos materiales de lo que ya no pudo excavar la retroexcavadora.



Foto 23. Se inicia la limpieza de la limpia de "dedo" en la parte más profunda de la cimentación.



Foto 24. A base de la cante con pico y pala.



Foto 25. Bombas sumergibles.



Foto 26. Para controlar las filtraciones hacia los cárcamos extremos y poder colocar las primeras capas de arcilla en seco se colaron unos bloques de concreto en la parte más angosta y profunda de la garganta en la foto se preparan las cimbres.



Foto 27. Aquí preparando las cimbres de estos bloques de concreto.



Foto 23. Se inicia el colado de estos bloques.

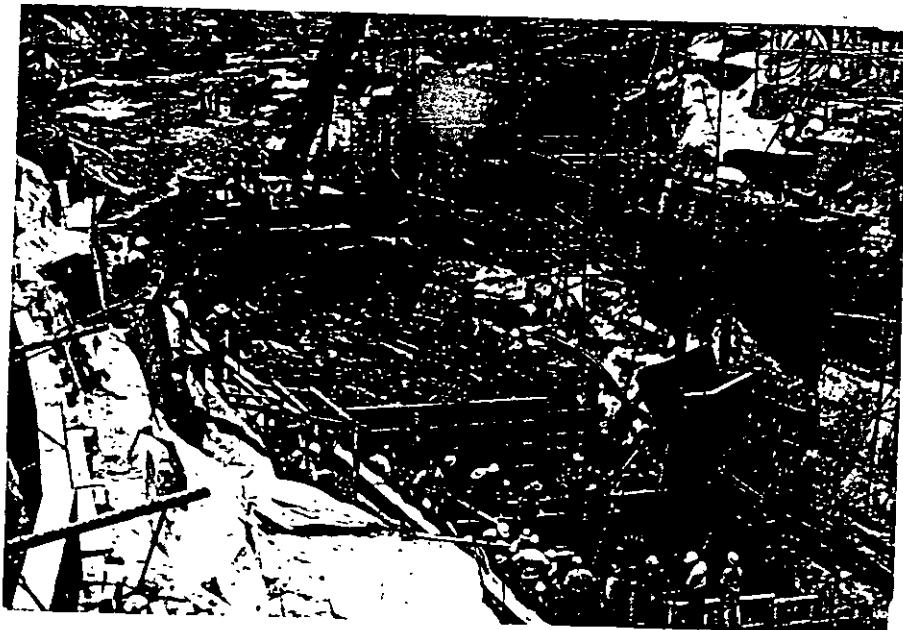

Foto 29. Detalles del contacto del concreto con la roca.

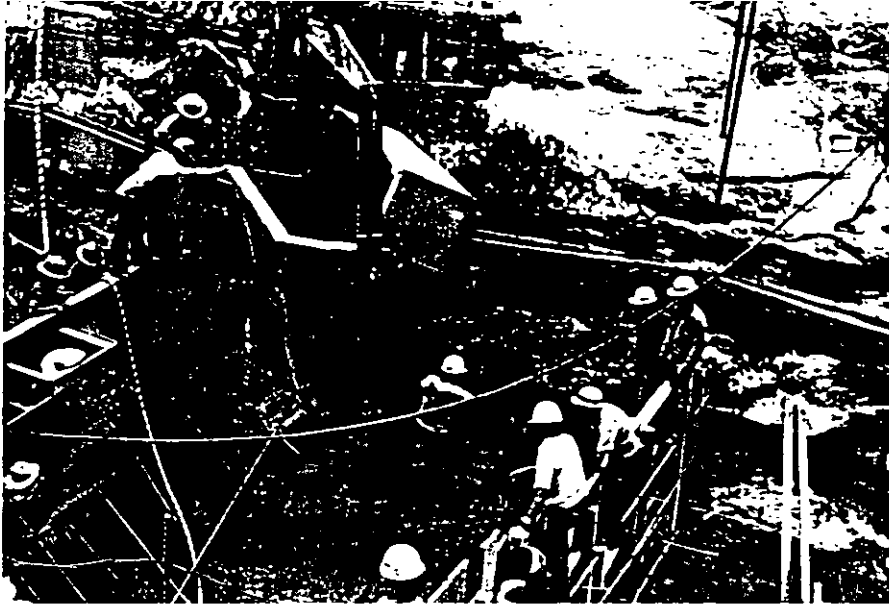

Foto 30. Detalle del contacto del concreto con la roca.



Foto 31. Detalle del contacto del concreto con la roca.



Foto 32. Aspecto del fondo con sus lozas coledas. Estas lozas sirvieron de apoyo para las inyecciones de tapete y pantalla.

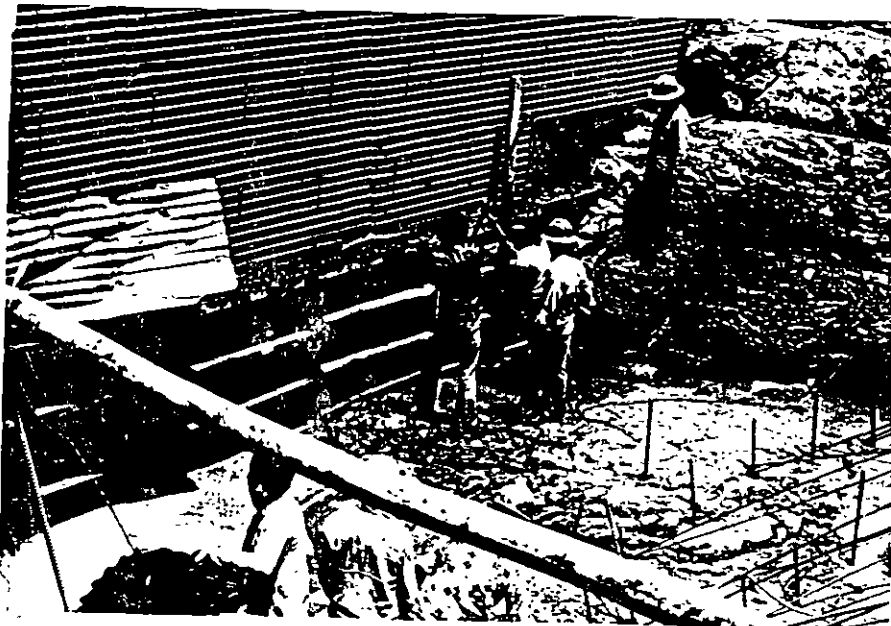

Foto 33. Un aspecto del fondo limpio.



Foto 34. Un aspecto del
fondo limpio.

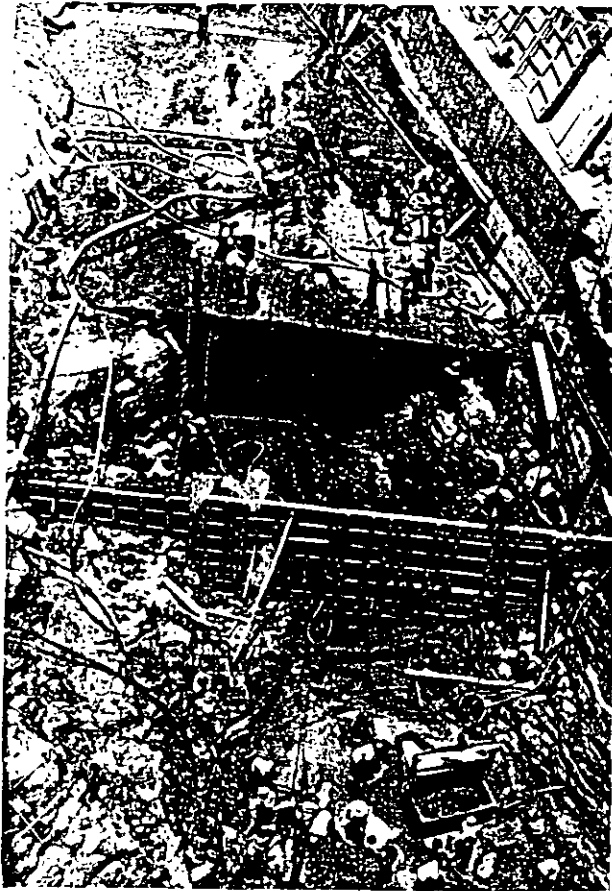

Foto 35. Tramos de tubo corruga-
do que se emplearon pa-
ra el control de las -
filtraciones en la roca.

¿QUE SIGNIFICA ROMPER LA BARRERA DE LOS
100 m. PLANOS?

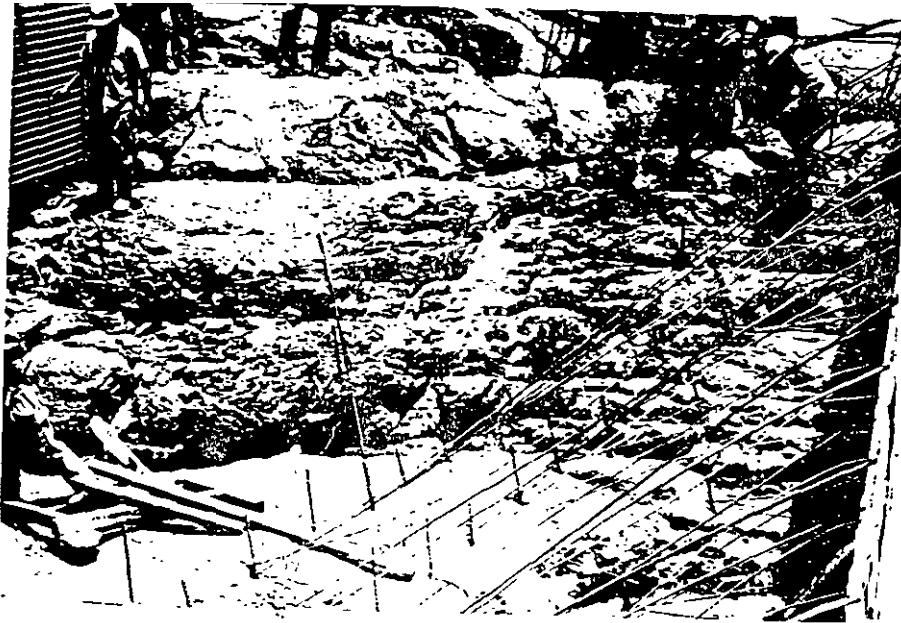
NOV/28/90

Supongamos que el corredor pesa 100 Kg. y desarrolla una velocidad media sostenida
de 10 m/seg

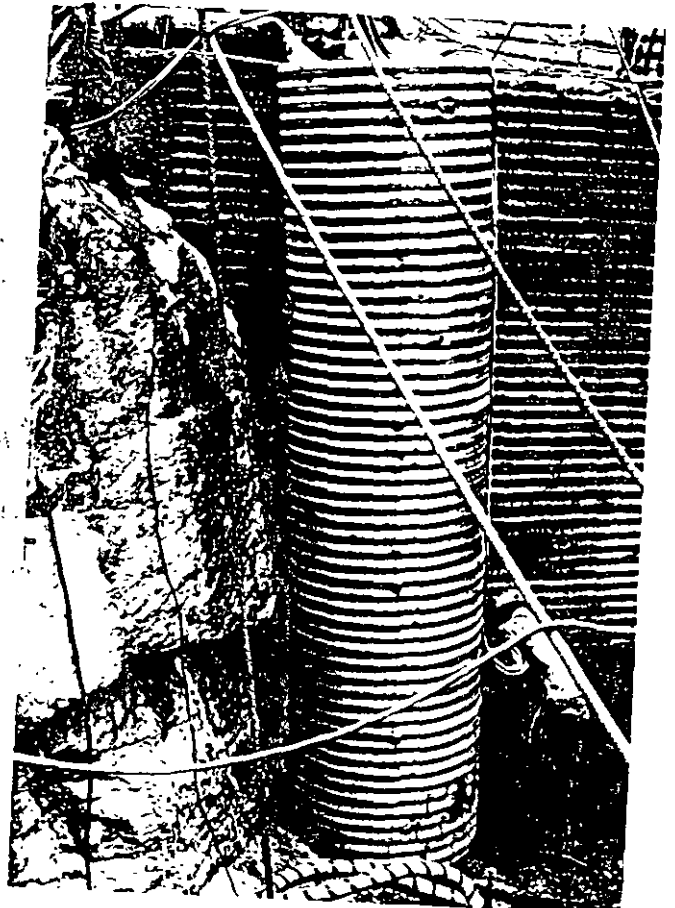
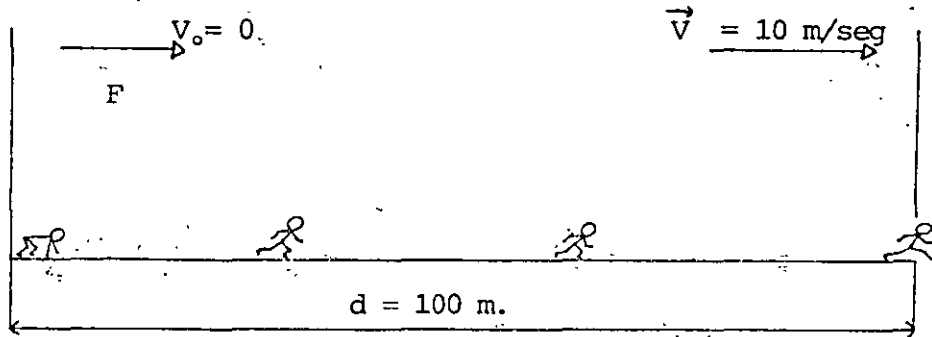

$$W = 100 \text{ Kg}_{\text{peso}} = 100 \times 9.81 = 981 \text{ Newtons}$$

$$F = m g$$

$$m = F / g$$

$$m = 981 \text{ N} / 9.81 =$$

$$m = 100 \text{ Kg}_{\text{masa}}$$

IMPULSO :

$$F \times t = m (V_f - V_0) = m \vec{V}$$

$$F \hat{=} \frac{m V}{t} = \frac{100 \text{ Kg}_{\text{masa}} \times 10 \text{ m} / \text{seg}}{10 \text{ seg}} = 100 \text{ N}$$

TRABAJO :

$$\mathcal{C} = \vec{F} \times d = 100 \text{ N} \times 100 \text{ m.} = 10,000 \text{ N}\cdot\text{m (Julios)}$$

POTENCIA :

$$P = \frac{F \times d}{t} = \frac{100 \text{ N} \times 100 \text{ m.}}{10 \text{ seg}} = 1000 \text{ N}\cdot\text{m/seg} = 1000 \text{ Julios/seg} = 1000 \text{ Watts} = 1 \text{ KW}$$

Significa desarrollar un esfuerzo físico equivalente a 1 KW de potencia

ENERGIA :

$$E = P \times t = 1 \text{ KW} \times 10 \text{ seg} = \frac{1 \text{ KW} \times 10 \text{ seg}}{3,600} = 0.002778 \text{ KW}\cdot\text{H}$$

Para generar un KW-H se requiere por ejemplo:

Descender en forma ordenada y sin fricción 10 m³ de agua desde una altura - de 36.71 m.

En Hidroeléctricas se acostumbra usar múltiplos de las Unidades de Potencia y Generación.

Potencia en Megawatts = MW = 1000 KW (10⁶ Watts)

Generación en Gigawatts-Hora = 1 millón de KW-H (10⁹ Watt-Hora)