



**DIVISION DE EDUCACION CONTINUA
FACULTAD DE INGENIERIA U.N.A.M.**

TELECOMUNICACIONES

VIA

SATELITE

JUNIO 1985

Los orígenes de la idea de satélites para comunicaciones no están muy claros, sin embargo, no hay duda de que la idea de satélite geostacionario fué propuesta por primera vez por Arthur C. Clarke en un artículo titulado Estaciones Extraterrestres, en la revista "Wireless World". Para esta idea, él tomó como referencia los cohetes utilizados por los alemanes durante la Guerra y la gran ventaja de la órbita geostacionaria. Proféticamente, su propuesta fué para usar estos satélites en cadenas de FM y no para servicio telefónico. Y por si esto fuera poco, Clarke también visualizó el uso en el espacio, de potencia eléctrica generada por paneles de celdas solares. La implementación de su idea tenía que esperar todavía hasta la era espacial (Sputnik - 1957) y la tecnología del estado sólido.

Han pasado 31 años desde su profecía y ya existen 22 programas de satélites de comunicaciones ya sea con satélites en órbita ó bajo construcción.

LAS DIFERENTES ETAPAS.

Al final de los 40's y principios de los 50's se demostraron reflexiones en la luna para su aplicación a radar y a sistemas de comunicaciones, Fig. 1. En julio de 1954, los primeros mensajes de voz fueron transmitidos por la Marina de los Estados Unidos sobre la trayectoria de la tierra a la luna y viceversa. En 1956, se estableció un enlace haciendo uso de la luna, entre Washington D.C. y Hawaii. Este circuito operó hasta 1962, ofreciendo comunicación segura a larga distancia, teniendo como única limitación la disponibilidad de la luna en los sitios de transmisión y de

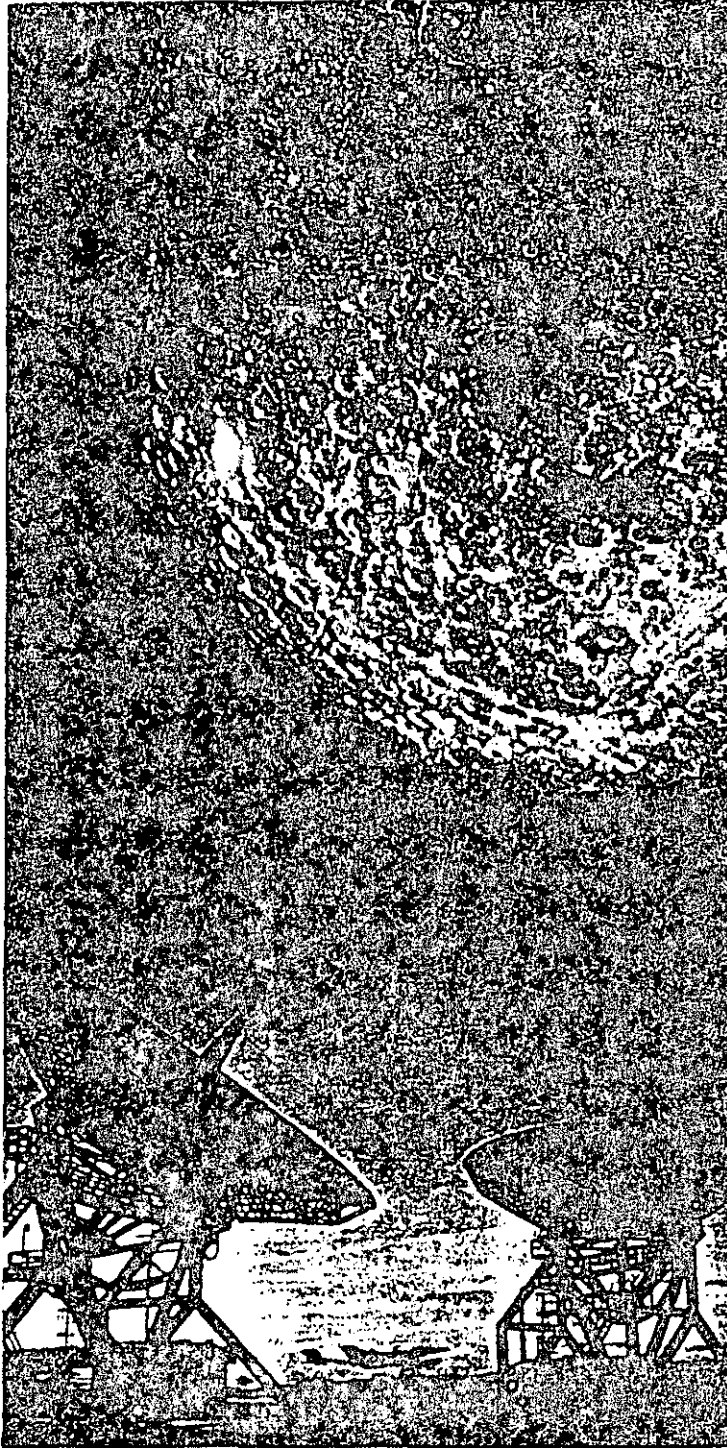


Fig. 1. Reflexiones en la luna.

recepción. La potencia usada fué de 100 kw, con antenas de 26-m de diámetro a una frecuencia de 430 MHz.

En 1958 surge el proyecto SCORE, el cual consistía en satélites del tipo grabación y retransmisión con un peso de 150 libras y a una órbita entre 110 y 920 millas, Fig. 2.

Dos años después, conjuntamente con los laboratorios Bell, NASA y JPL, se realizó el experimento ECHO, Fig. 3. Exitosas comunicaciones se establecieron a la largo de los Estados Unidos, primeramente entre Goldstone, CA, y Holmdel, NJ, a frecuencias de 960 MHz y 2290 MHz. El balón ECHO, hecho de plástico y cubierto de aluminio con un diámetro de 100 pies, estaba a una órbita inclinada de 1500 kms. de altitud y era visible al ojo humano, el ECHO II se instaló entre 1000 y 1200 kms. Más tarde y en el mismo mes, ocurrió la primera transmisión transatlántica entre Holmdel, N.J. y una estación receptora en Francia. Este proyecto alertó a todo el mundo sobre la prosperidad del nuevo medio de comunicación, aunque el método específico, nunca fué explotado comercialmente.

Aunque los satélites pasivos tienen capacidad infinita para comunicaciones de acceso múltiple, existe la inconveniencia del ineficiente uso de la potencia de transmisión. En el experimento ECHO, por ejemplo, solamente una parte de la potencia transmitida (10 Kw) era reflejada a la tierra ($\frac{1}{10^{18}}$).

El primer satélite repetidor activo fué el Courier (1960), Fig. 4. Aceptaba y almacenaba hasta 360,000 palabras de teletipo. Operó por 17 días con 3 watts de potencia de salida y trabajando a una órbita entre 600 y 700 millas.

De los años experimentales, tal vez, el proyecto más conocido es el Telstar, Fig. 5, posiblemente porque fué el primero ca-

paz de retransmitir a través del Atlántico programas de T.V. Este proyecto fué iniciado por la ATT y desarrollado por los laboratorios Bell, quienes habían adquirido considerable experiencia y conocimiento de los trabajos anteriores, como el proyecto ECHO. El primer Telstar fué lanzado de Cabo Cañaveral el 10 de julio de 1962. Era una esfera de aproximadamente 87 cm. de diámetro, con un peso de 80 kg. El vehículo de lanzamiento era un cohete Thor-Delta el cual colocó al satélite en una órbita elíptica con apogeo de 5600 km, y un período de 2 1/2 horas. Telstar II fué hecho con más resistencia a la radiación por la experiencia con el Telstar I, de lo demás fué exactamente igual al anterior. Fué lanzado exitosamente el 7 de mayo de 1963.

La potencia de Telstar I y II de 2.25 w fué suministrada por un TWT con un ancho de banda de radiofrecuencia de 50 MHz en las bandas de 4 y 6 GHz. Ambos satélites fueron estabilizados por giro. La capacidad total fué de 600 canales telefónicos ó un canal de T.V. Estos satélites estaban a una órbita de 682 a 4030 millas.

Por los mismos años (1963), RCA y NASA orbitaron el satélite RELAY (Fig. 6) con frecuencias de operación de 1.7 y 4.2 GHz, con 10 watts de salida y órbitas de 942 y 5303 millas.

En 1963, la fuerza aérea de los Estados Unidos logró poner en órbita un cinturón orbital compuesto de pequeños dipolos a 2300 millas, el cual actuaba como un reflector pasivo, se transmitió voz en forma digital de una forma inteligible. Este proyecto fué el famoso WEST FORD, Fig. 7.

En este mismo año se lanzó el primer satélite de comunicaciones en órbita geoestacionaria. Este satélite fué puesto en órbita por la NASA y se utilizó para múltiples experimentos.

Transmitió señales de TV en los juegos olímpicos de Tokio en 1964, fué el SYNCOM, Fig. 8.

Las comunicaciones comerciales por satélite comenzaron oficialmente en 1965, cuando se lanzó el primer satélite comercial en el mundo, fué el INTELSAT I (Pájaro Madrugador), - - Fig. 10.

En el mismo año la Unión Soviética pone en órbita el Molniya, que fué el primero de muchos satélites de comunicaciones, puesto a gran altitud con órbita elíptica, Fig. 9.

En enero de 1966 INTELSAT I fué puesto fuera de servicio cuando la cobertura en el Atlántico y en el Pacífico fué lograda por INTELSAT II e INTELSAT III, Figs. 11 y 13.

El LES-6, un pequeño satélite de banda lateral en la banda de UHF y el TACSAT I, un poderoso satélite de UHF y SHF formaron el programa TACSATCOM para operaciones militares en los Estados Unidos a lo largo del mundo, esto fué en 1968 y 1969. Un satélite TACSAT tenía 1000 watts de potencia y transmitía 10,000 canales de voz. Fig. 12.

La fase de madurez total en los satélites de comunicaciones probablemente arribó con la llegada del INTELSAT IV en 1971. Estas naves del espacio pesan aproximadamente 730 Kg. (Fig. 14) en órbita y proveen no solamente cobertura de la tierra sino también dos rayos dirigidos a un punto específico de Europa, Norte ó Sudamérica. INTELSAT IV es un satélite de giro, como sus predecesores, pero con todo un ensamble de antenas; consistente de 13 diferentes antenas, se ajusta continuamente hacia un punto de la tierra. Los dos rayos dirigidos se forman por dos antenas parabólicas. Cada satélite provee aproximadamente 6000 circuitos de voz, o más, dependiendo de cómo se divida la potencia en el satélite entre los rayos dirigidos

y los de cobertura terrestre. El sistema INTELSAT IV puede conducir 12 canales de color de TV al mismo tiempo.

En 1972, Telstar de Canadá pone en órbita el primer satélite doméstico en el mundo. Este satélite es el famoso ANIK, - - Fig. 15, con capacidad de 5000 canales de voz y 300 watts de potencia.

Estados Unidos lanza su primer satélite doméstico en 1974, el Westar (Fig. 16), el cual inicia una nueva era en las comunicaciones de ese país.

El sistema INTELSAT IV fué puesto en órbita en 1980 en la región del Océano Atlántico con una capacidad de casi 25000 canales.

1958: SCORE (NASA)

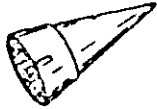


Fig. 2 Un satélite de 150 lbs. que radia un mensaje de navidad grabado del Presidente Eisenhower. Altura de la órbita: de 110 a 920 millas.

1960: ECHO (NASA)



Fig. 3 Un balón de plástico de 100 pies de diámetro con revestimiento de aluminio el cual refleja pasivamente las señales de radio desde una inmensa antena terrestre. Altura de la órbita: 1000 millas; ECHO II: de 600 a 800 millas.

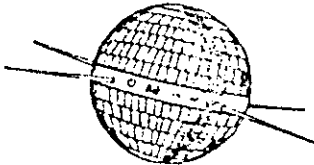
1960: COURIER
(Department of Defense)

Fig. 4 El primer satélite repetidor activo. Aceptaba y almacenaba hasta 360,000 palabras de teletipo. Operó por 17 días con 3 watts de potencia de salida. Altura de órbita: de 600 a 700 millas.

1962 TELSTAR (AT&T)

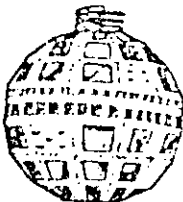


Fig. 5 El primer satélite para recibir y -- transmitir simultáneamente. 4/6 GHz. Utilizado para telefonía, televisión, facsimil y datos. 3 watts de potencia de salida. Altura de la órbita: de 682 a 4030 millas.

1962: RELAY (RCA and NASA)

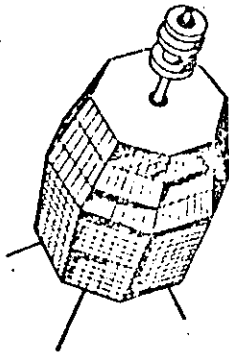


Fig. 6 Satélite de 4.2/1.7GHz, con potencia de salida de 10 watts. Altura de la órbita: de 942 a 5303 millas

(U.S. Air Force)
1963: PROJECT WEST FORD

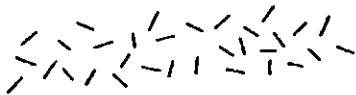


Fig. 7 Un cinturón orbital de pequeños dipolos fué lanzado a una altura de 2300 millas para actuar como un reflector pasivo. La voz en forma digitalizada se transmitió inteligiblemente.

1963: SYNCOM (NASA)

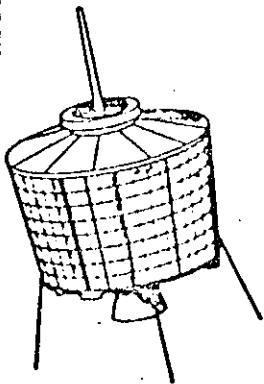


Fig. 8 El primer satélite de comunicaciones en órbita geostacionaria. Utilizado para muchos experimentos. Transmitió televisión en los Juegos Olímpicos de Tokio en 1964.

1965: MOLNIYA

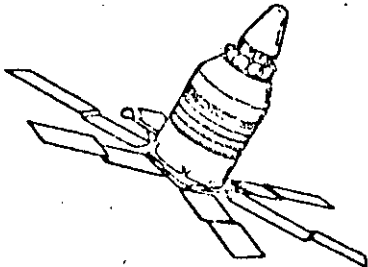


Fig. 9 El primero de muchos satélites de comunicaciones rusos a una órbita elíptica de gran altitud.

1965. EARLY BIRD (INTELSAT)

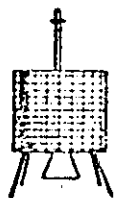


Fig. 10 El primer satélite de comunicaciones comerciales en el mundo, operado por COMSAT. 240 canales de voz. 40 watts de potencia de salida.

1966: INTELSAT II

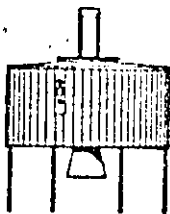


Fig. 11 El segundo satélite de COMSAT. El primer satélite comercial de acceso múltiple con capacidad de multi destino. 240 circuitos de voz. 75 watts de potencia de salida.

1968: LES-6
1969: TACSAT I
(U.S. Military)

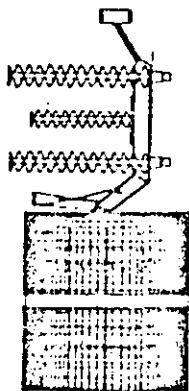


Fig. 12 El LES-6, es un pequeño satélite de UHF de banda única y el TACSAT I es un poderoso satélite en las bandas de UHF y SHF. Ambos formaron el programa TACSATCOM para múltiples operaciones militares en los Estados Unidos. Un satélite TACSAT tenía 1000 watts de potencia y transmitía 10,000 canales de voz.

1968: INTELSAT III

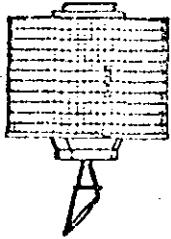


Fig. 13

La tercera generación COMSAT. 1200 circuitos de voz. Una antena direccional de cobertura terrestre. 120 watts de potencia de salida.

1971: INTELSAT IV

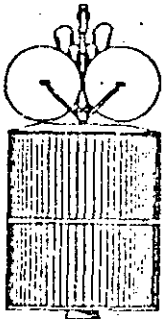


Fig. 14

La cuarta generación COMSAT. 6000 circuitos de voz. Una antena de cobertura terrestre y dos de haces dirigidos. 400 watts de potencia de salida.

1972: ANIK (Telesat Canada)

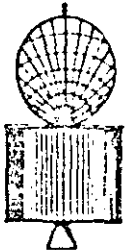


Fig. 15

El primer satélite doméstico en el mundo diseñado por Canadá. 5000 circuitos de voz. 300 watts de potencia.

1974: WESTAR (Western Union)

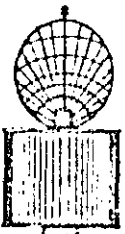


Fig. 16

El primer satélite doméstico en los Estados Unidos. El inicio de una nueva era en las comunicaciones Norte-Americanas.

LAS ERAS DE LOS SATELITES DE COMUNICACIONES

ERA SUBSINCRONA	1958 - 1963
ERA SINCRONA GLOBAL	1964 - 1972
ERA GLOBAL Y DOMESTICA REGIONAL	1973 - 1981
ERA DE NEGOCIOS Y DE ESTACIONES TERMINALES PEQUEÑAS	1981 - 1985
ERA DE SATELITES DE RADIODIFUSION	1985 - 1990
ERA DE PLATAFORMAS ESPACIALES Y SATELITES INTELIGENTES-PROCESA- DORES EN EL CIELO	1990 ———

ORBITAS

Los satélites de comunicaciones modernos tienen órbitas muy diferentes de sus predecesores en el ámbito experimental, tales como Telstar de ATT y Relay de RCA. Estos últimos viajaban rápidamente alrededor de la tierra a una relativamente baja altura. Los satélites Telstar tenían órbitas elípticas muy altas, Telstar I de 600 a 3800 millas y Telstar II de 600 a 6200 millas. El apogeo de la elipse fue puesto en posición tal que el satélite estaba dentro de la línea de vista de ciertas estaciones tanto tiempo como fuera posible. Como con los primeros vuelos espaciales tripulados y muchos otros satélites lanzados en la primera década de los vuelos espaciales, los satélites viajaban alrededor de la tierra en pocas horas: Telstar I, 2 horas y 38 minutos, y Telstar II, 3 horas y 45 minutos. Aquí aparece entonces la desventaja para las telecomunicaciones; estaban dentro de la línea de vista de la estación de rastreo, por sólo un breve período de tiempo, algunas veces menos de media hora.

Los rusos también usaron órbitas elípticas para sus satélites de comunicación Molniya, pero sus órbitas son mayores tal que los satélites están dentro de línea de vista por largos períodos de tiempo. La Fig. 17 grafica el tiempo que toma un satélite para viajar alrededor de la Tierra contra su altura. La órbita a una altura de 22300 millas es especial en la que un satélite a esa altura toma exactamente 24 horas para viajar alrededor de la Tierra (el tiempo de rotación de la Tierra). Si su órbita está sobre el Ecuador y lleva la misma dirección que la superficie de la Tierra, entonces se puede ver como estacionario desde un punto sobre la Tierra. Esta órbita es llamada órbita geostacionaria.

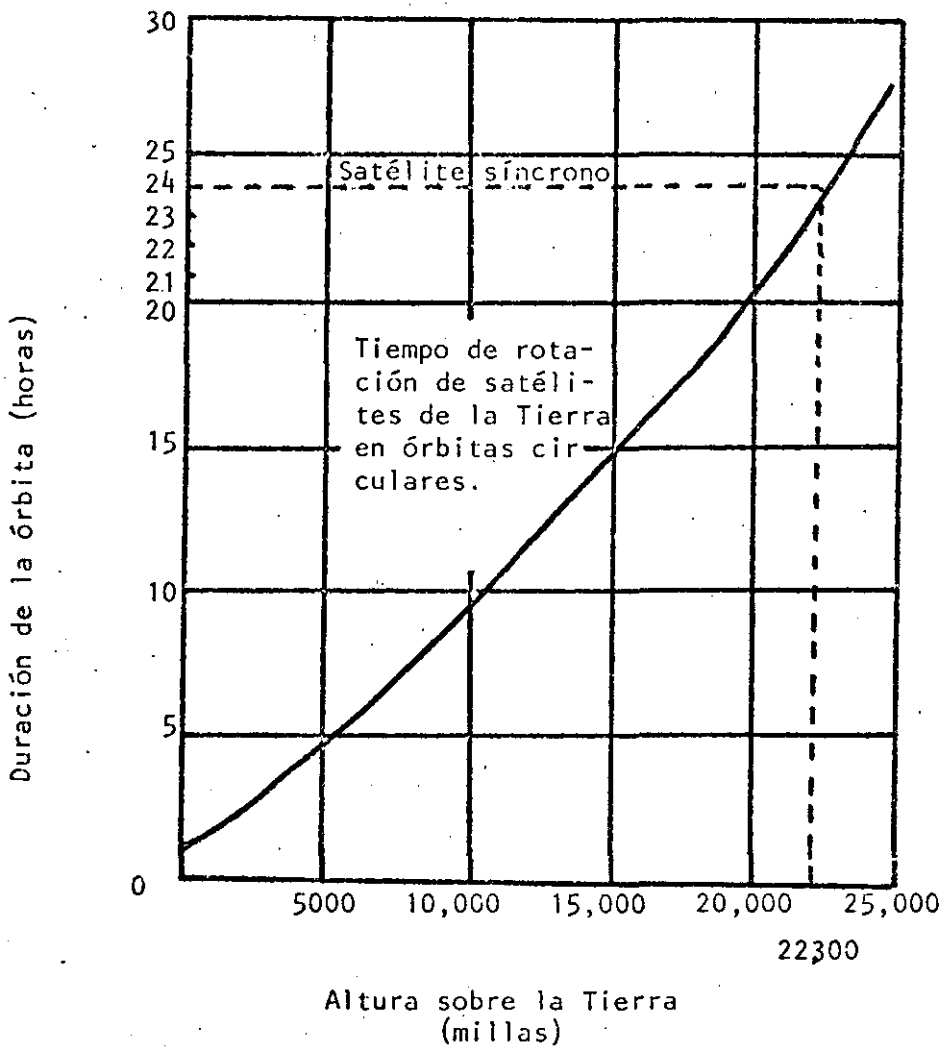


Fig. 17

Los satélites INTELSAT son estacionarios sobre el Atlántico y el Pacífico. Los satélites domésticos de E.U. se encuentran también estacionarios en Sudamérica o el Pacífico, sobre el Ecuador. La Fig. 18 muestra las órbitas de los satélites.

El área de vista de un satélite en esa órbita es aproximadamente un tercio del globo.

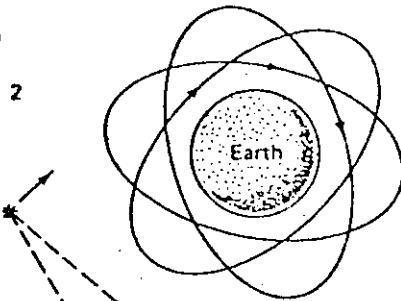
Para comunicaciones intercontinentales, los satélites se colocan en órbita geoestacionaria sobre cada una de las tres áreas de los océanos (Fig. 19). Algunas órbitas típicas se detallan también en la Fig. 20.

La Fig. 21 muestra el máximo espaciamiento entre estaciones terrenas para diferentes alturas de satélites, considerando que 5° es el ángulo mínimo de elevación de las estaciones terrenas. En la Fig. 22 se muestran las distancias y tiempos de propagación de un satélite geoestacionario.



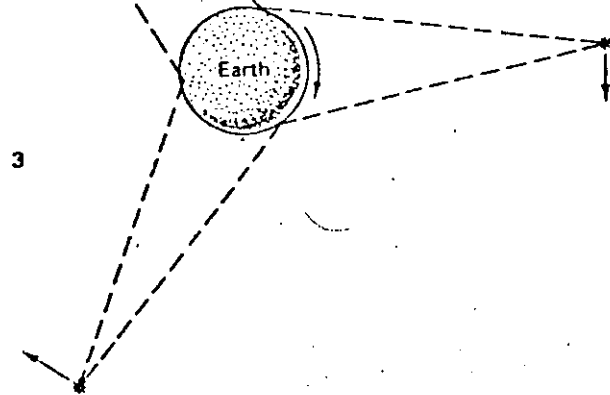
Satélite de órbita baja

Altura : 100-300 millas
 Período de rotación: 1 1/2 horas aprox.
 Tiempo en línea de vista: $\frac{1}{4}$ hr. ó menos



Satélite de altitud media

Por ejemplo, el satélite ruso de comunicaciones Molniya y los satélites AT y T's.
 Altura típica: 6000-12000 millas
 Período de rotación típico: 5-12 hrs.
 Tiempo típico en línea de vista 2-4 hrs



Satélite Geoestacionario

Por ejemplo, INTELSAT, WESTAR

Altura: 22300 millas
 Período de rotación: 24 hrs.
 Tiempo en línea de vista:
 Toda la vida del satélite la órbita es sobre el Ecuador.

Fig. 18 Órbitas del satélite.

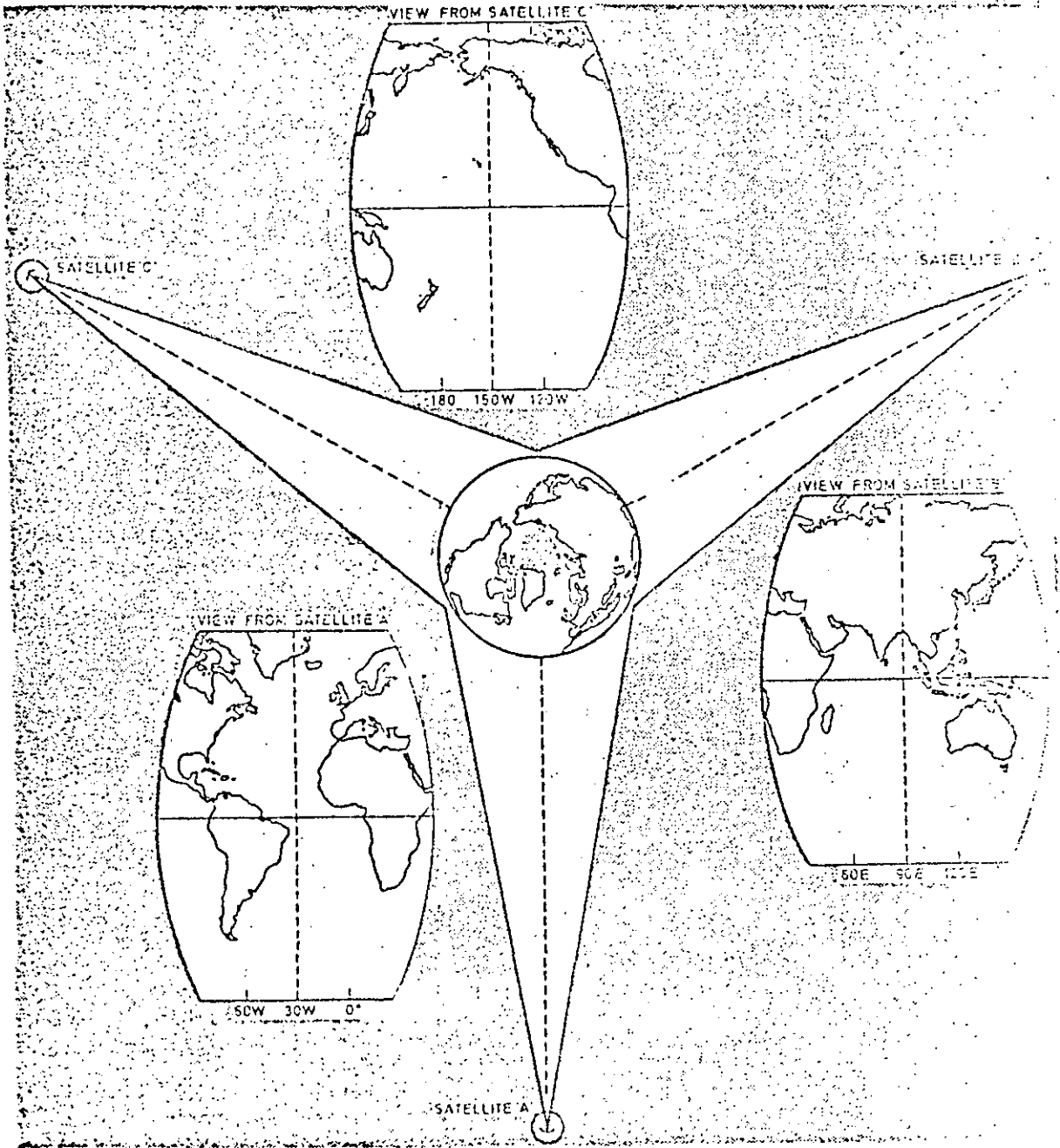


FIGURE 19 WORLD WIDE COVERAGE

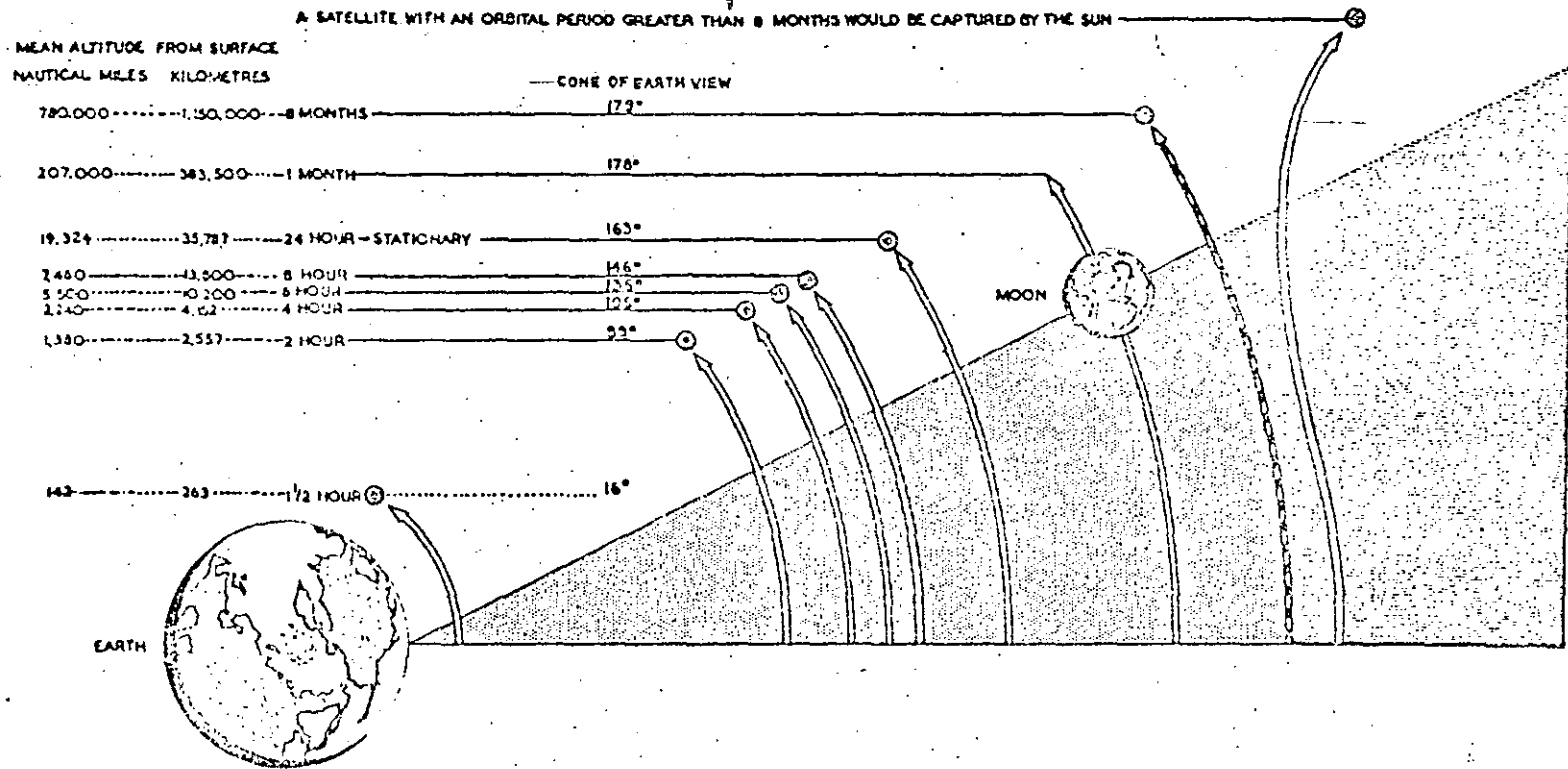


FIGURE 20 ORBIT RELATIONSHIPS

17.

17

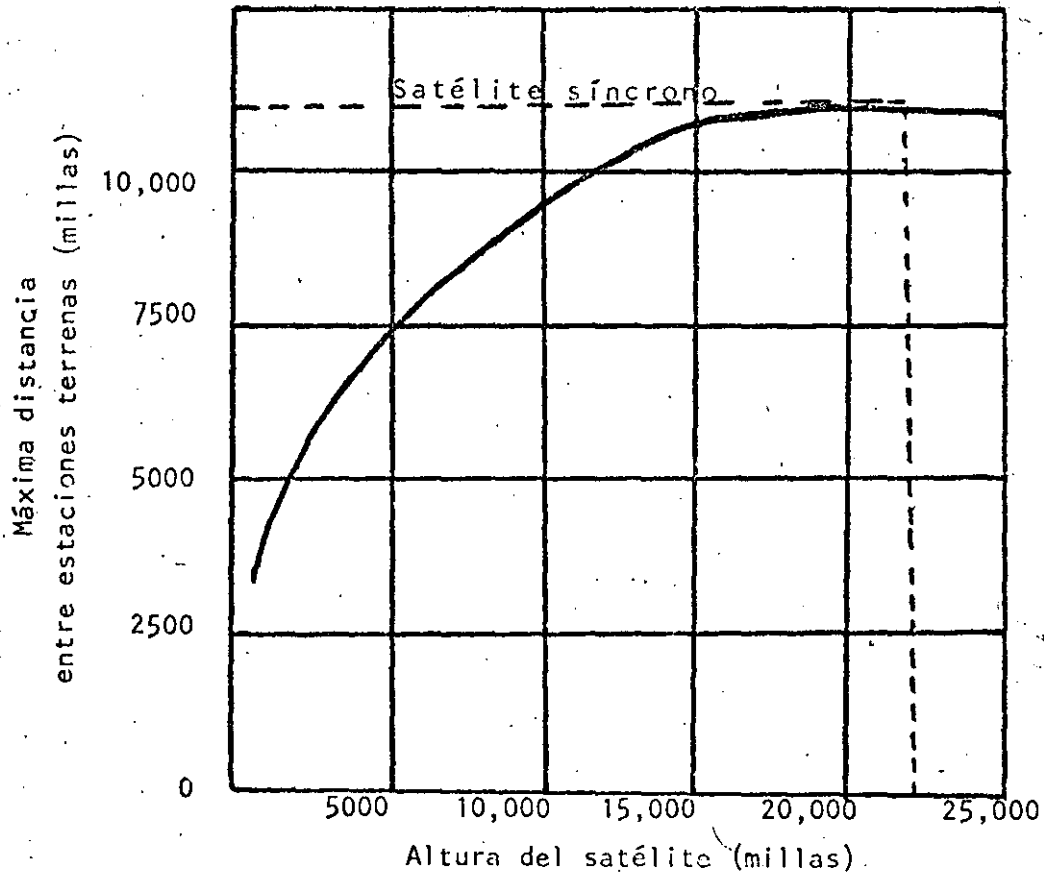


Fig. 21 Máxima separación de las estaciones terrenas

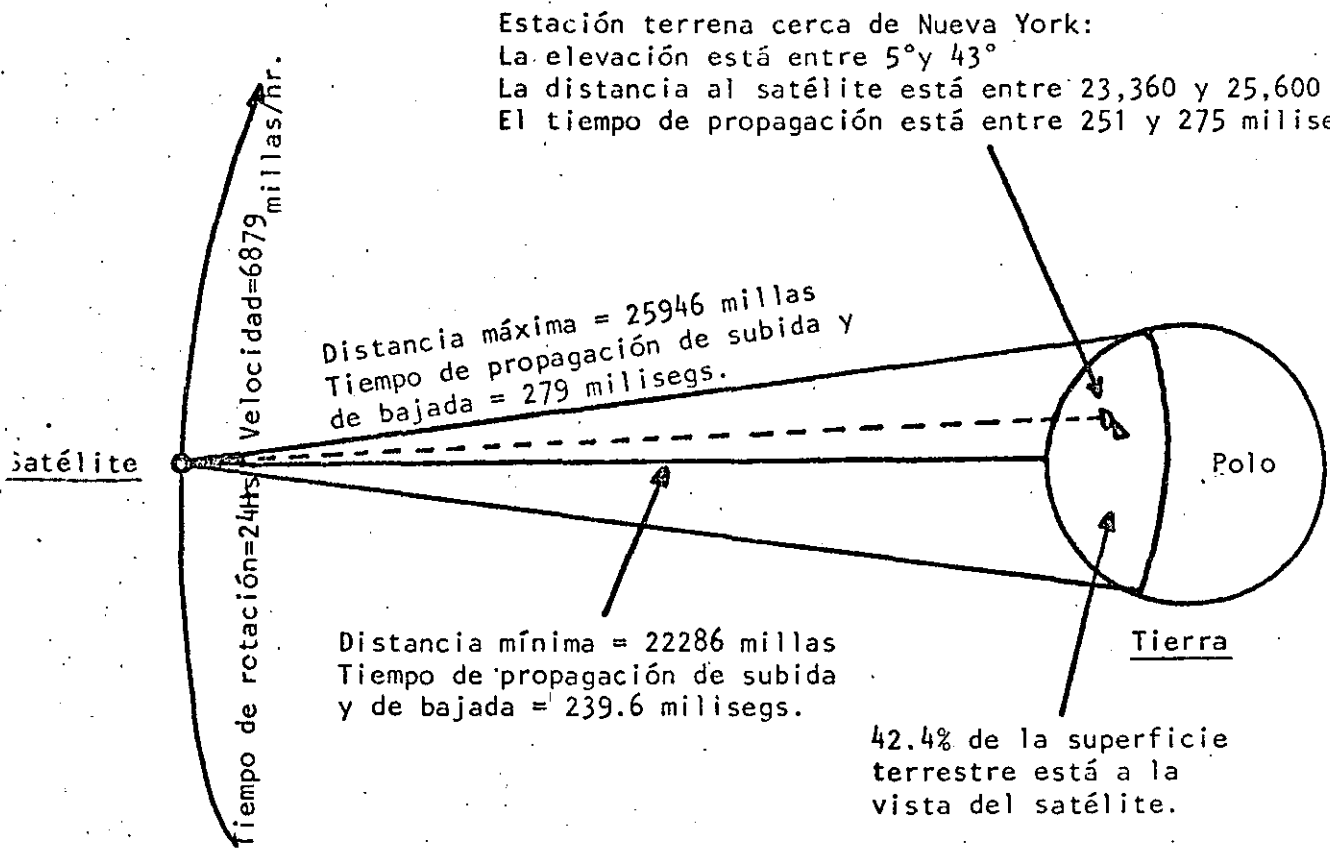


Fig. 22 Distancias y tiempos de propagación con un satélite geostacionario.

VENTAJAS DE LA ORBITA GEOESTACIONARIA

1. El satélite se mantiene casi estacionario con respecto a las antenas de la Tierra.
2. No hay interrupciones en la transmisión.
3. Debido a la distancia, un satélite geoestacionario está en línea de vista en el 42.4% de la superficie de la Tierra, por lo tanto un gran número de estaciones terrenas pueden intercomunicarse.
4. Tres satélites son suficientes para una cobertura total de la Tierra.
5. Casi no existe el efecto Doppler.

DESVENTAJAS DE LA ORBITA GEOESTACIONARIA

1. No se cubren las latitudes mayores de $81,25^\circ$ norte y sur.
2. Existe una atenuación considerable y el tiempo de retraso es de 270 milisegundos.

Orbital Position		Space station	GHz	Frequency Bands											
				<1	<3	4	6	7	11	12	14	>15			
75	E	USA	FITSATC INDN	1						7					
77	E	INS	PALAPA-2				4	6							
80	E	URS	STATIONAR-3				4	6							
80	E	URS	STATIONAR-13				4	6							
83	E	INS	PALAPA-1				4	6							
85	E	URS	GALS-3						7						
85	E	URS	LOUTCH-P3							11		14			
85	E	URS	STATIONAR-3				4	6							
85	E	URS	VOLNA-3	1	3										
90	E	URS	LOUTCH-3							11		14			
90	E	URS	STATIONAR-4				4	6							
90	E	URS	VOLNA-4		3										
94	E	IND	INSAT-1B	1	3		4	6							
95	E	URS	STATIONAR-14				4	6							
99	E	URS	STATIONAR-7	1				6							
99	E	URS	STATIONAR-12	1				6							
102	E	IND	ISCOM	1			4	6							
108	E	INS	PALAPA-B1				4	6							
110	E	J	BSE		3							14			
113	E	INS	PALAPA-B2				4	6							
118	E	INS	PALAPA-B3				4	6							
125	E	CHN	STW-1				4	6							
130	E	J	ETS-2	1	3					11			14		
130	E	J	CS-2A		3		4	6						20/30	
130	E	URS	STATIONAR-15				4	6							
135	E	J	CS-2B		3		4	6						20/30	
135	E	J	CSE		3		4	6						18/29	
140	E	J	GMS	1	3										
140	E	URS	LOUTCH-4							11		14			
140	E	URS	STATIONAR-7				4	6							
140	E	URS	VOLNA-6		3										
172	E	USA	FITSATC W PAC	1						7					
174	E	USA/IT	INTELSAT4 PAC1				4	6							
174	E	USA/IT	INTELSAT4A PAC1				4	6							
174	E	USA	INTELSAT5 PAC1				4	6		11		14			
175	E	USA	USG/CSS PHASE2 W PAC							7					
175	E	USA	USG/CSS PHASE2 W PAC							7					
176.5	E	USA	MAFISAT-PAC	1	3		4	6							
179	E	USA/IT	INTELSAT4 PAC2				4	6							
179	E	USA/IT	INTELSAT4A PAC2				4	6							
179	E	USA	INTELSAT5 PAC2				4	6		11		14			
172	W	F/MRS	MARECS-B	1	3		4	6							
170	W	URS	GALS-4						7						
170	W	URS	LOUTCH-P4							11		14			
170	W	URS	STATIONAR-10				4	6							
170	W	URS	VOLNA-7	1	3										
149	W	USA	ATS-1	1			4	6							
136	W	USA	US SATCOM-1				4	6							
135	W	USA	GOLS WEST	1	3										
135	W	USA	USG/CSS PHASE2 E PAC							7					
135	W	USA	USG/CSS PHASE2 E PAC							7					
132	W	USA	US SATCOM-3				4	6							
128	W	USA	COMSTAR D1				4	6							
123.5	W	USA	WESTAR-2				4	6							
122	W	USA	USASAT-6A							11		14			
119	W	USA	US SATCOM-2				4	6							
116	W	CAN	ANIK-C2							11		14			
114	W	CAN	ANIK-A3				4	6							
112.5	W	CAN	ANIK-C1							11		14			
109	W	CAN	ANIK-A2				4	6							
109	W	CAN	ANIK-B1				4	6		11		14			
106	W	USA	USASAT-6B							11		14			
105	W	USA	ATS-3	1	3										
104	W	CAN	TELESAT D-1				4	6							

Orbital Position	Space Station		Frequency Bands											
			GHz	<1	<3	4	6	7	11	12	14			
104	W	CAN	ANIK-A1				4	6						
102	W	MEX	SATMEX-1				4	6						
100	W	USA	FLTSATC I PAC	1						7				
99	W	USA	WLSTAR-1				4	6						
95	W	USA	COMSTAR D2				4	6						
91	W	USA	WESTAR-3				4	6						
87	W	USA	COMSTAR D3				4	6						
86	W	USA	ATS-3	1										
75.4	W	CLM	SATCOL-2				4	6						
75	W	USA	GOLS EAST	1	3									
75	W	CLM	SATCOL-1				4	6						
34.5	W	USA	INTELSAT MCS ATL E			3	4	6						
34.5	W	USA/IT	INTELSAT4 ATL5				4	6						
34.5	W	USA/IT	INTELSAT4A ATL4				4	6						
34.5	W	USA/IT	INTELSAT5 ATL4				4	6		11		14		
31	W	USA/IT	INTELSAT4A ATL4				4	6						
29.5	W	USA/IT	INTELSAT4 ATL2				4	6						
29.5	W	USA/IT	INTELSAT4A ATL3				4	6						
29.5	W	USA/IT	INTELSAT5 ATL3				4	6		11		14		
27.5	W	USA/IT	INTELSAT4A ATL3				4	6						
27.5	W	USA/IT	INTELSAT5 ATL3				4	6		11		14		
27.5	W	USA/IT	INTELSAT MCS ATL B	3			4	6						
25	W	URS	GALS-1						7					
25	W	URS	LOUTCH-PI							11		14		
25	W	URS	STATIONAR-B				4	6						
25	W	URS	VOLNA-1	1	3									
24.5	W	USA	INTELSAT MCS ATL D			3	4	6						
24.5	W	USA/IT	INTELSAT4A ATL1				4	6						
24.5	W	USA/IT	INTELSAT5 ATL1				4	6		11		14		
23	W	USA	FLTSATC ATL	1						7				
21.5	W	USA	INTELSAT MCS ATL C	3			4	6						
21.5	W	USA	INTELSAT5 ATL5				4	6		11		14		
21.5	W	USA/IT	INTELSAT4 ATL2				4	6						
21.5	W	USA/IT	INTELSAT4A ATL1				4	6						
19.5	W	USA/IT	INTELSAT4 ATL3				4	6						
19.5	W	USA/IT	INTELSAT4A ATL2				4	6						
18.5	W	USA/IT	INTELSAT4 ATL3				4	6						
18.5	W	USA/IT	INTELSAT4A ATL2				4	6						
18.5	W	USA/IT	INTELSAT5 ATL2				4	6		11		14		
18.5	W	USA/IT	INTELSAT MCS ATL A			3	4	6						
18	W	BEL	SATCOM-III ATL							7				
18	W	BEL	SATCOM-III							7				
18	W	BEL	SATCOM-II							7				
15	W	F/MRS	MARECS-A	1	3	4	6							
15	W	F	SIRIO	1						11				
15	W	USA	MARISAT ATL	1	3	4	6							
14	W	URS	LOUTCH-1							11		14		
14	W	URS/IK	STATIONAR-4				4	6						
14	W	URS	VOLNA-2			3								
13	W	USA	USGCS PHASE2 ATL							7				
12	W	USA	USGCS PHASE2 ATL							7				
12	W	USA	USGCS PHASE2 ATL							7				
11.5	W	F/SYM	SYMPHONIE-2	1			4	6						
11.5	W	F/SYM	SYMPHONIE-3	1			4	6						
10	W	F	TELECOM-1A			3	4	6	7		12	14		
8.5	W	URS	STATIONAR-11				4	6						
7	W	F	TELECOM-1B			3	4	6	7		12	14		
4	W	USA/IT	INTELSAT4 ATL1				4	6						
1	W	USA/IT	INTELSAT4 ATL4				4	6						

* Under co-ordination RR639AJ

Advanced publication only under RR639AA

(courtesy of International Telecommunication Union)

FRECUENCIAS.

Las bandas de frecuencias que se han determinado para comunicaciones vía satélites se ilustran en la tabla I. La tabla II muestra las frecuencias para sistemas móviles marítimos y aeronáuticos.

Las frecuencias que más se usan actualmente son esas que están abajo de 14.5 GHz. Arriba de 10 GHz, la propagación a través de la atmósfera de la tierra es afectada por la lluvia, la cual produce una atenuación suficientemente grande para afectar el comportamiento del sistema. Las componentes para sistemas de comunicación de banda amplia se obtienen fácilmente en las bandas de 2,4 y 6 GHz, habiéndose desarrollado éstas para los sistemas LOS. Consecuentemente, los sistemas existentes han operado principalmente en las bandas de 4 y 6 GHz, para satélites civiles y en las bandas de 7-8 GHz para sistemas militares. INTELSAT V usa las bandas de 11.7/14.0 GHz y desde luego las de 4/6 GHz. Los sistemas OTS y ECS usarán 11,7/14,0 GHz exclusivamente.

La congestión en las bandas de 4/6GHz ha forzado que en los nuevos sistemas se consideren mayores frecuencias, pero, hasta la fecha, las bandas de 4/6 GHz han sido las más atractivas. La órbita geoestacionaria, vista desde la Tierra, se extiende hasta 120° en longitud; la separación típica de los satélites es de 3°, para prevenir que las estaciones terrenas causen interferencia a satélites adyacentes, así que todo el sector de la órbita geoestacionaria puede acomodar a 40 satélites operando en la misma frecuencia. En la región visible a los Estados Unidos existen cerca de 20 satélites operando en las bandas de 4 y 6 GHz. Los satélites marítimos MARISAT Y MAROTS usan las bandas 1535-1542,5 y 1636-1644 GHz para enlaces barcos-satélites pero 4/6 o 12/14 para enla

Servicio de Satélite Fijo	Frecuencia	Satélites de Radiodifusión	Notas
	606 - 790 MHz	Bajada	
	2500 - 2535	Bajada doméstica	S
	2535 - 2550	Bajada y	S
	2550 - 2655	Bajada comunitaria	S
Subida	2655 - 2690	Subida	S
Bajada	3400 - 3600		S, también usada para rada
Bajada	3600 - 4200		S
Bajada	4500 - 4800		S
Subida	5725 - 5850		P
	5850 - 7075	(áreas limitadas solamente)	S
Bajada	7250 - 7450		S
Bajada	7300 - 7450		S
Bajada	7450 - 7750		S
Subida	7900 - 8025		S
Subida	8025 - 8215		S
Subida	8215 - 8400 MHz		S
Bajada	10.70 - 11.7 GHz	Enlaces de sub., región 1 unic.	S
	11.70 - 12.5	Bajada	S
Subida	12.75 - 13.25		S
Subida	14.0 - 14.25		P
Subida	14.25 - 14.3		P
Subida	14.3 - 14.8		S
	17.3 - 18.10	Subida	S
Bajada	17.7 - 19.7		S
Bajada	19.7 - 21.2		P
Subida	27.5 - 29.5		S
Subida	29.5 - 31		P
Bajada	37.5 - 40.5		S
	40.5 - 42.5	Bajada	S
Bajada	42.5 - 43.5		S
Subida	47.2 - 51.4		S
Bajada	81 - 84		S
	84 - 86	Bajada	S
Subida	92 - 95		S
Bajada	102 - 105		S
Subida	140 - 142		S
Bajada	149 - 164		S
	202 - 217		S
	231 - 238 GHz		S
	265 - 275		S

N.B : P = Servicio Primario

S = Compartida con otros servicios.

Tabla 1 : Distribuciones de frecuencias para servicios fijos de satélites y satélites de radiodifusión.

FRECUENCIA	MOVIL AERONAUTICO	MOVIL MARITIMO	MOVIL TERRESTRE
1530 - 1535 MHz		S	
1535 - 1544		E	
1544 - 1545	S	S	
1545 - 1549	E		
1626.5 - 1644.5		E	
1644.5 - 1646.5	S	S	S
1646.5 - 1660	E		
1660 - 1660.5	S		
14.0 - 14.5 GHz			S
43.5 - 47.0			S
66.0 - 71.0			S
95 - 100			S
134 - 142			S
252 - 265			S

Compartida

Exclusiva

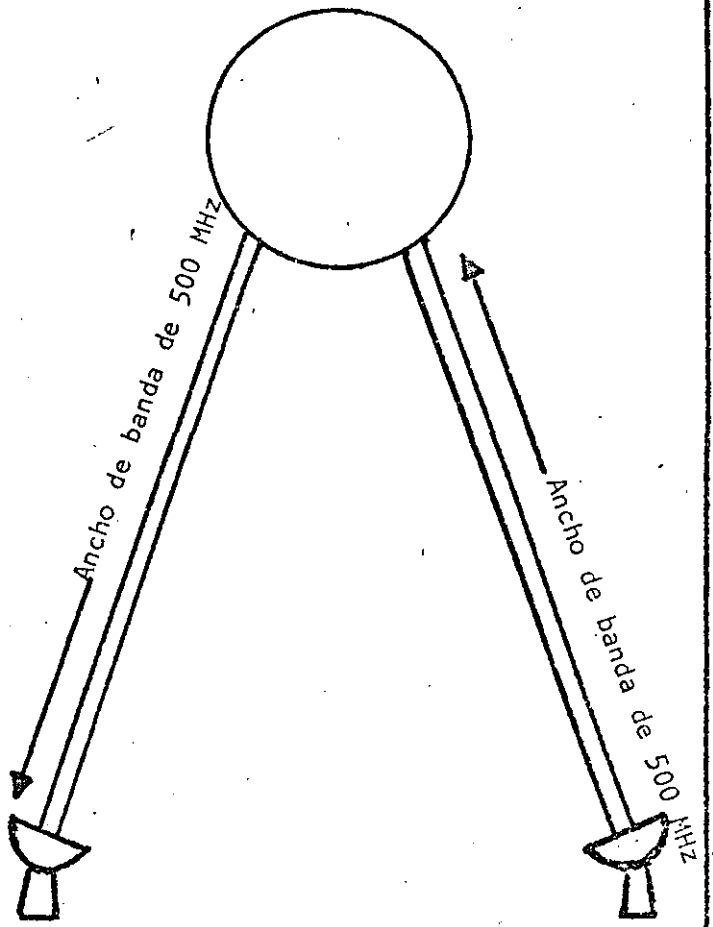
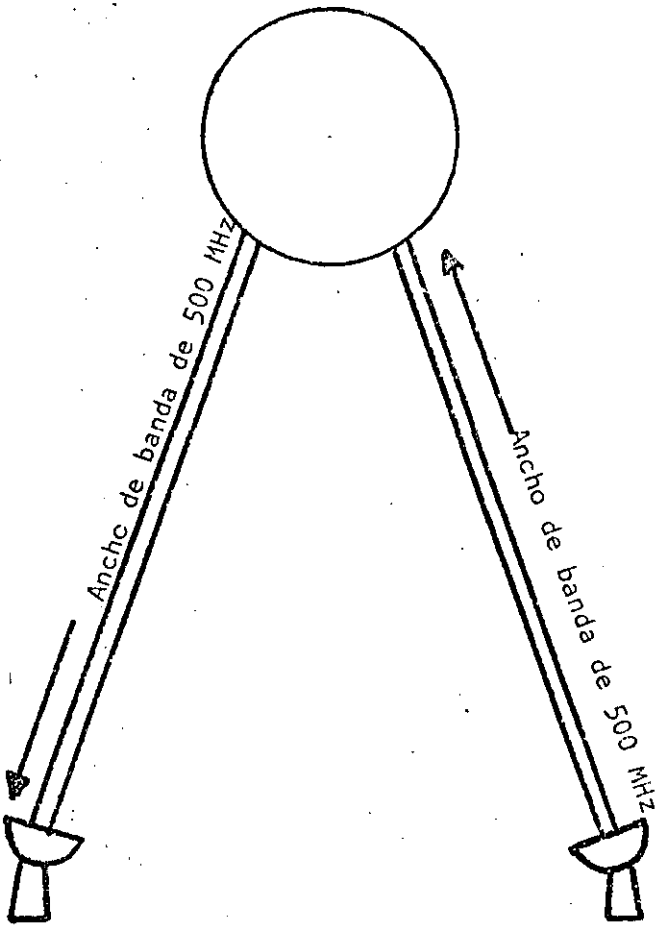
La mayoría de las bandas de servicio de satélites fijos arriba de 3.4 GHz pueden también ser usadas por terminales móviles, para enlaces de subida y de bajada.

Tabla II

Frecuencias para servicios móviles.

Frecuencias utilizadas por la mayoría de los satélites actuales

Frecuencias destinadas para satélites de gobierno y militares



Bajada
3.7 a 4.2 GHz

Subida
5.925 a 6.425GHz

Bajada
7.25 a 7.75 GHz

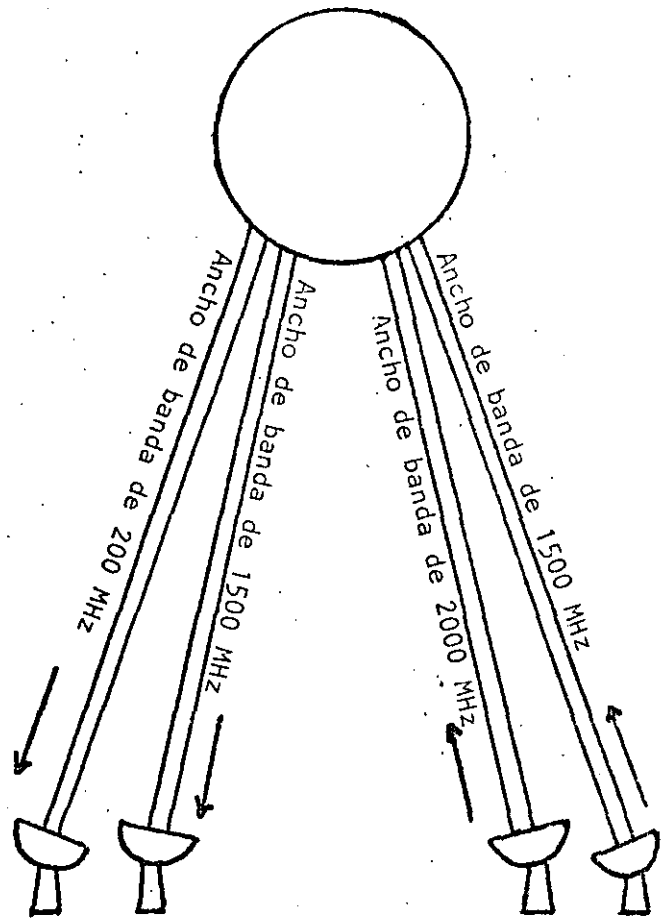
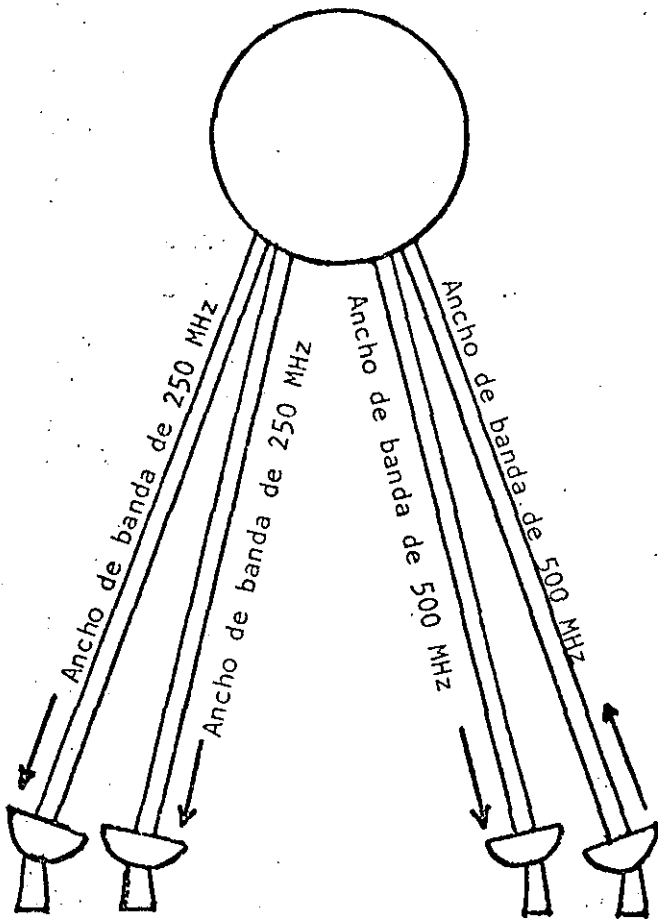
Subida
7.9 a 8.4 GHz



Existe una fuerte congestión en estas bandas de frecuencias, debido a que son las mismas utilizadas en microondas terrestres.

Otras frecuencias utilizadas

Frecuencias permitidas pero todavía sin uso debido a que se requiere más desarrollo.



Enlaces de bajada
10.95 a 11.2 GHz
11.45 a 11.7 GHz

Enlaces de bajada re-
gión 2
11.7 a 12.2
(Hemisferio
oeste, Nor-
te y Sud-
América)

Enlaces de subida
14.0 a 14.5

Enlaces de bajada
17.7 a 19.7 GHz
19.7 a 21.2 GHz

Enlaces de su-
bida
27.5 a 29.5 GHz
29.5 a 31.0 GHz

ces satélites-Tierra. Las estaciones terrenas grandes pueden lograr muy buen desempeño a las frecuencias altas, dejándose las bandas de 1500 MHz para los enlaces barcos-satélites, donde es difícil instalar grandes antenas en lugares precisos.

En general, es más fácil y barato usar las frecuencias más bajas. Sin embargo, se limita el ancho de banda y la interferencia es mayor, ya que estas frecuencias se usan para sistemas terrestres. Las frecuencias más altas ofrecen la ventaja de mayores anchos de banda pero como ya se había dicho se presentan dificultades en la propagación. Además, las antenas de un diámetro dado pueden producir haces más angostos a frecuencias mayores, así que los satélites regionales pueden ser hechos más directivos en la parte alta del rango de frecuencias. La frecuencia no aparece en la ecuación de enlace si se fija el tamaño de la antena transmisora en el satélite.

VENTAJAS DE FRECUENCIAS MENORES A 10 GHz

- MENOR ABSORCIÓN ATMOSFERICA.
- MENOR RUIDO.
- SE TIENE UNA TECNOLOGIA BIEN DESARROLLADA.
- MENOR ATENUACION.

DESVENTAJAS DE FRECUENCIAS MENORES A 10 GHz

- LAS BANDAS SON COMPARTIDAS CON SERVICIOS TERRESTRES.
- CONGESTIONAMIENTO DE LA ORBITA.

VENTAJAS DE FRECUENCIAS MAYORES A 10 GHz

- MENOR INTERFERENCIA.
- SE PUEDEN COMPARTIR CON SERVICIOS TERRESTRES.
- FACILIDAD EN LA ORBITA.

DESVENTAJAS DE FRECUENCIAS MAYORES A 10 GHz

- MAYOR ATENUACION.
- MAYORES EFECTOS POR LLUVIA Y GASES ATMOSFERICOS.

EL SISTEMA DE COMUNICACIONES.

Un modelo general que representa un sistema de comunicaciones vía satélite se ilustra en la Fig. 23. La señal se genera por un usuario y entra al sistema terrestre. En algunos sistemas, el sistema terrestre es simplemente un enlace dedicado a la estación terrena, mientras en otros casos es una red telefónica de conmutación. En la estación terrena se procesa la señal de banda base y se transmite a una frecuencia de radio-frecuencia (RF) al satélite donde se procesa y se retransmite a la estación terrena receptora. La estación terrena procesa la señal hasta la señal de banda base la cual se envía al usuario a través de la red terrestre, la Fig. 24 muestra un diagrama simplificado de la estación terrena.

El primer modelo del sistema de comunicación de interés es el modelo FI a FI mostrado en la Fig. 25. Este modelo considera que existe un solo haz desde la antena del satélite, el cual ilumina todas las estaciones terrenas del sistema.

Las características de interés en el modelo que serán discutidas son:

1. La técnica de acceso múltiple.
2. La potencia de la estación terrena y la ganancia de la antena.
3. El ruido y la interferencia.
4. El canal de subida.
5. La ganancia de la antena receptora del satélite.
6. El receptor del satélite.
7. El transpondedor del satélite.
8. La potencia del satélite y la ganancia de la antena.
9. El canal de bajada.
10. La estación terrena y el receptor.

El amplio reflector del satélite ATS-6 se agrega grandemente al EIRP.

El canal de bajada se muestra en la Fig. 28. La potencia de recepción en la estación terrena será:

$$P_b = \text{EIRP}_{\text{sat}} - L_b - L_e + G_T$$

donde G_T es la ganancia de la estación terrena.

Primero, considérese la trayectoria de transmisión desde una estación terrena a otra vía satélite. El primer paso es obtener las ecuaciones de enlace. El modelo del enlace de subida se muestra en la Fig. 26. La densidad de flujo en el satélite está dada por

$$F_s = \text{EIRP} - 10 \log (4\pi d^2) \text{ w/m}^2$$

donde EIRP es la potencia efectiva radiada isotrópicamente y es la potencia del transmisor tomando en cuenta la ganancia de la antena y las pérdidas en las líneas.

d es la distancia de la trayectoria.

La potencia de la señal recibida en el satélite es:

$$P_s = \text{EIRP} - L_s - L_e + G_{ss}$$

donde L_s es la atenuación en el espacio libre, L_e otras atenuaciones y G_{ss} es la ganancia de la antena del satélite. La Fig. 27 muestra la relación entre el tamaño de la antena y su ganancia.

El EIRP de los satélites se ha incrementado con el tiempo, ya que tanto la potencia del transmisor como la ganancia de la antena han aumentado conforme los satélites generan más y más potencia y conforme tengan mayor facilidad para desplegar las antenas. La siguiente tabla muestra el incremento

AÑO	SATELITE	EIRP(watts)
1965	INTELSAT I	14
1967	INTELSAT II	36
1968	INTELSAT III	200
1971	INTELSAT IV	6400
1974	ATS-6	140000

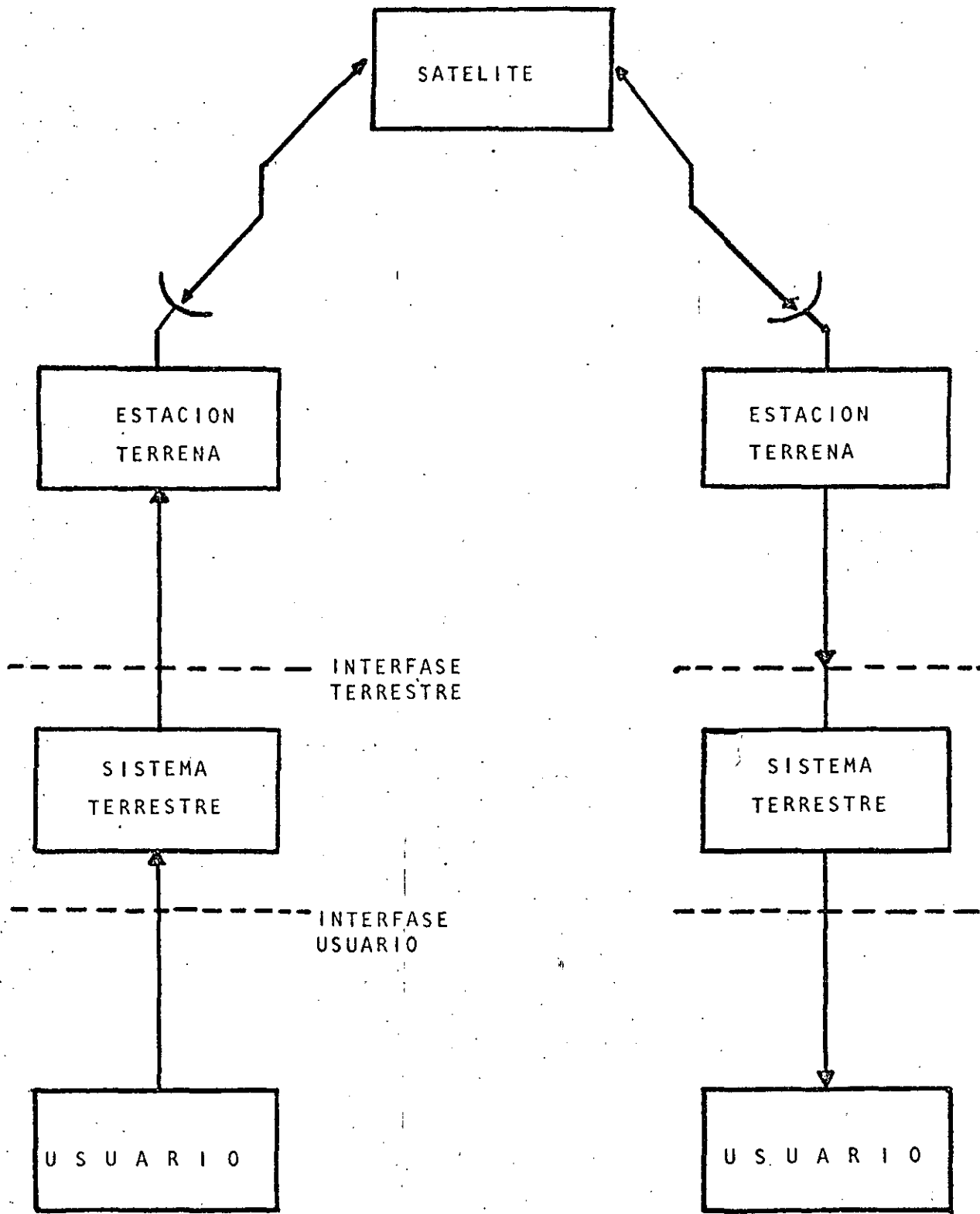


Fig. 23 SISTEMAS DE COMUNICACION POR SATELITE

Estación Terrena

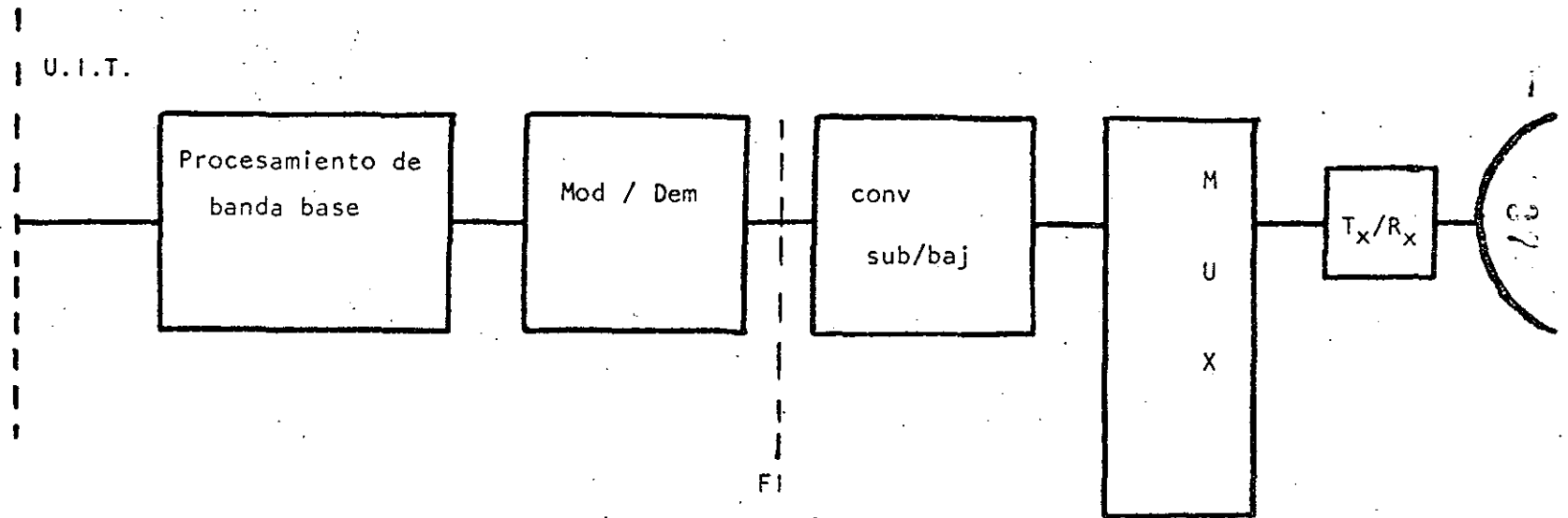


Fig. 29 Estación Terrena

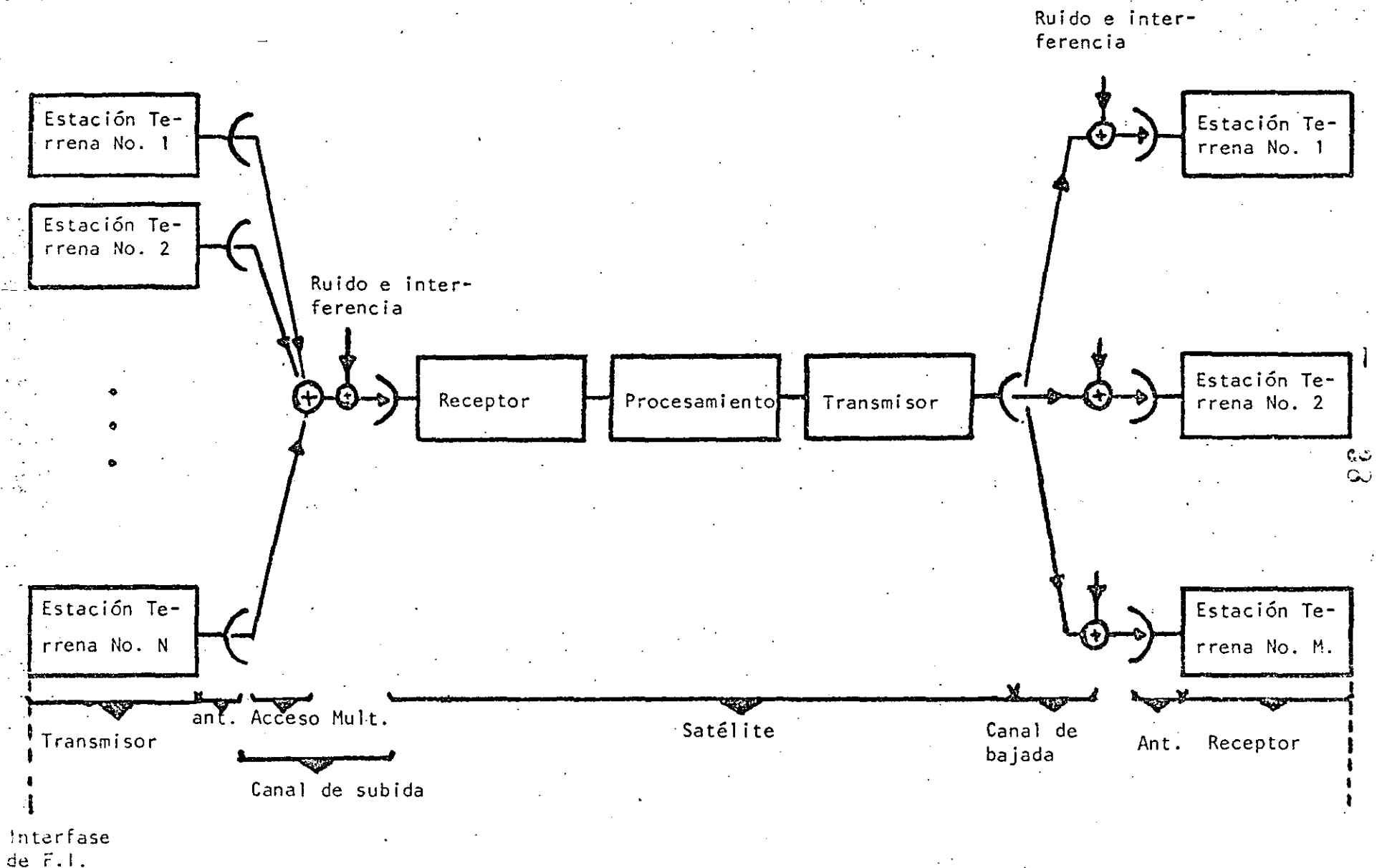


Fig. 25 Modelo de un sistema de comunicación (FI- a FI)

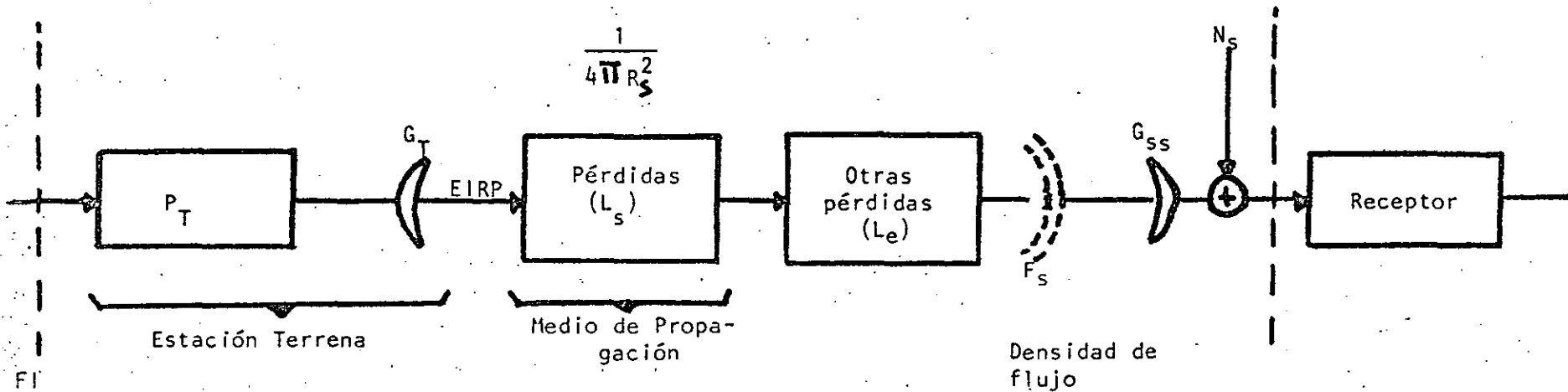


Fig. 26 Modelo de subida.

$$\text{EIRP (dBw)} = P_T \text{ (dBw)} + G_T$$

$$\text{Pérdidas } (L_s) = 20 \log f + 20 \log d + 32.46$$

$$\left(\frac{C}{N}\right)_s = \text{EIRP} - (L_s + L_e) + G_{ss} - 10 \log (KTB)$$

$$\left(\frac{C}{N}\right)_s = \text{EIRP} - (L_s + L_e) + \frac{G_{ss}}{T} - K - 10 \log B$$

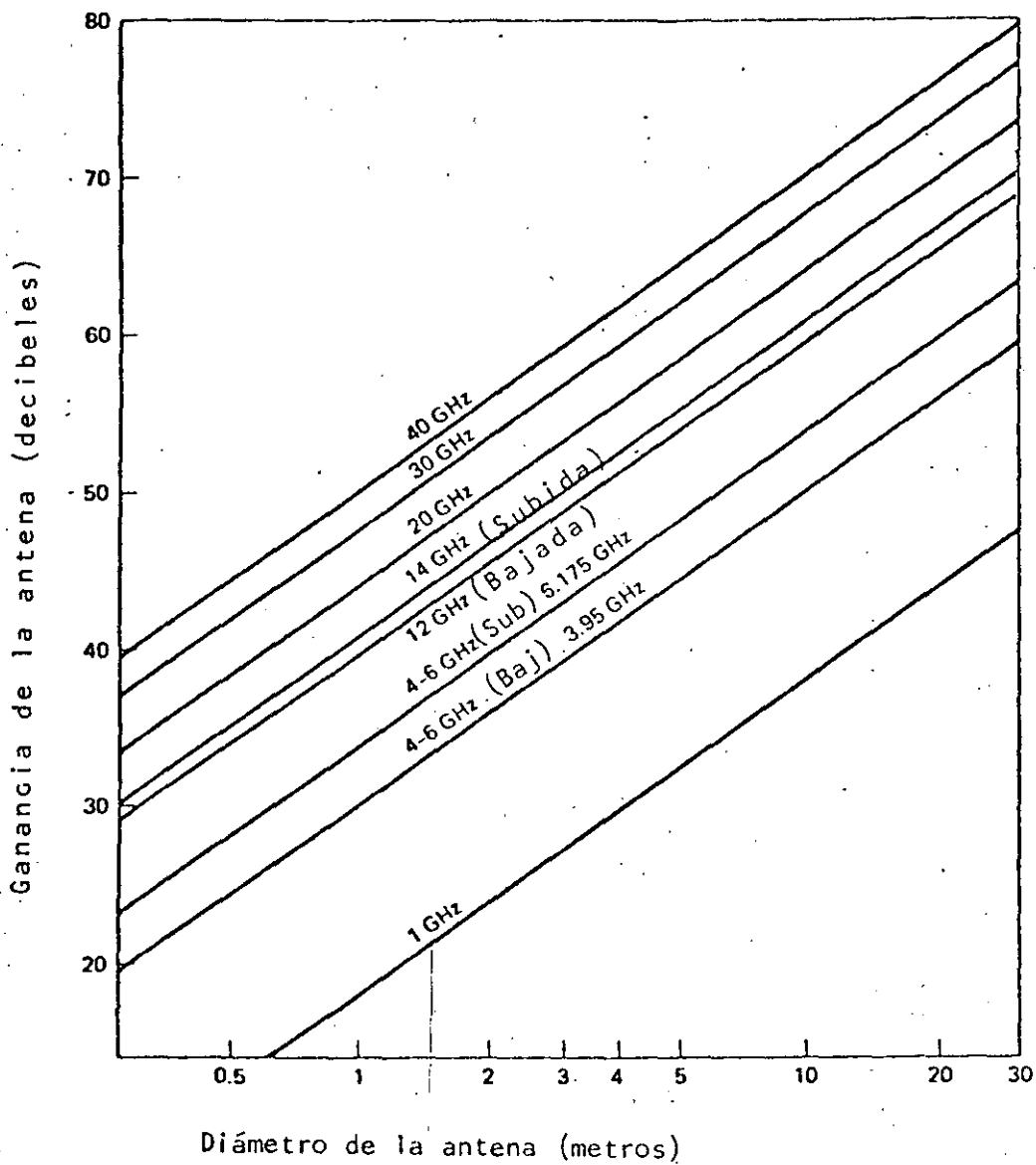


Fig. 27

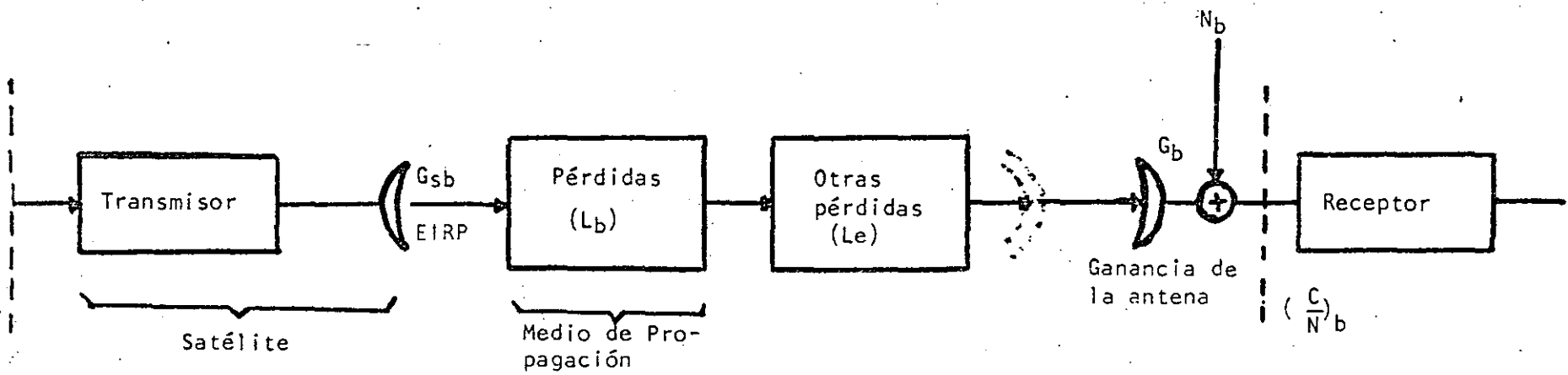


Fig. 28 Modelo de bajada.

$$\text{EIRP (dBW)} = P_s \text{ (dBW)} + G_{sb} \text{ (dB)}$$

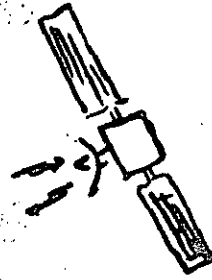
$$\text{Pérdidas (L}_b) = 20 \log f + 20 \log d + 32.46$$

$$\left(\frac{C}{N}\right)_b = \text{EIRP} - (L_b + L_e) + G_b - 10 \log (KTB)$$

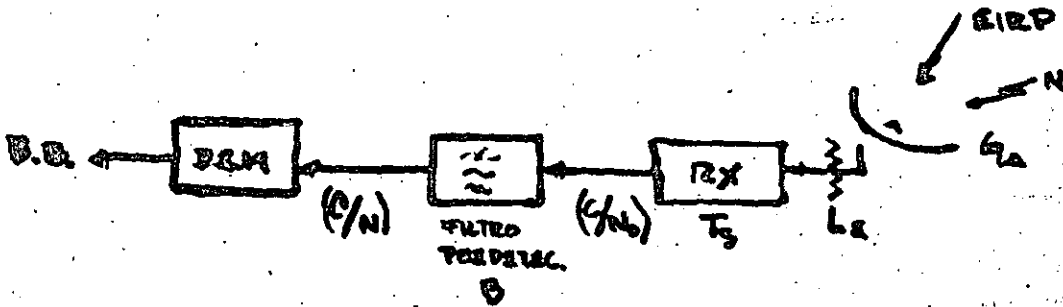
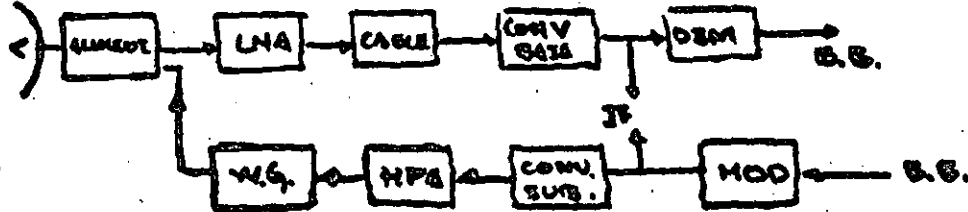
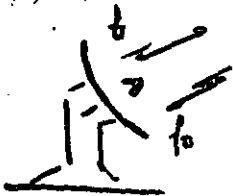
$$\left(\frac{C}{N}\right)_b = \text{EIRP} - (L_b - L_e) + \frac{G_b}{T} - K - 10 \log B$$

— ENLACE —

42



①



$$(S/N) = (C/N)_T + E.H. \quad \text{dB}$$

$$(C/N)_T = [(C/N)_u + (C/N)_o + (C/N)_f]$$

$$(C/N)_o = EIRP + (G_T) + 228.6 - L_s + F - L_a \quad \text{dB-Hz}^{-1}$$

$$EIRP = S + A_s - L \quad \text{dBW}$$

$$L_s = 20 \log (4\pi R \lambda^{-2})$$

$$A_s = 10 \log (4\pi R^2)$$

S es densidad d' flujo
 A_s es atenuación por dispersión.
 F es margen d' desvanecimiento.
 L_a es pérdidas d' equipo.

ATMOSFERA

(2)

TROPÓSFERA

 $h \leq 16 \text{ km}$

ESTRATÓSFERA

 $T < h, 16 \text{ km} < h < 50 \text{ km}$

MESÓSFERA

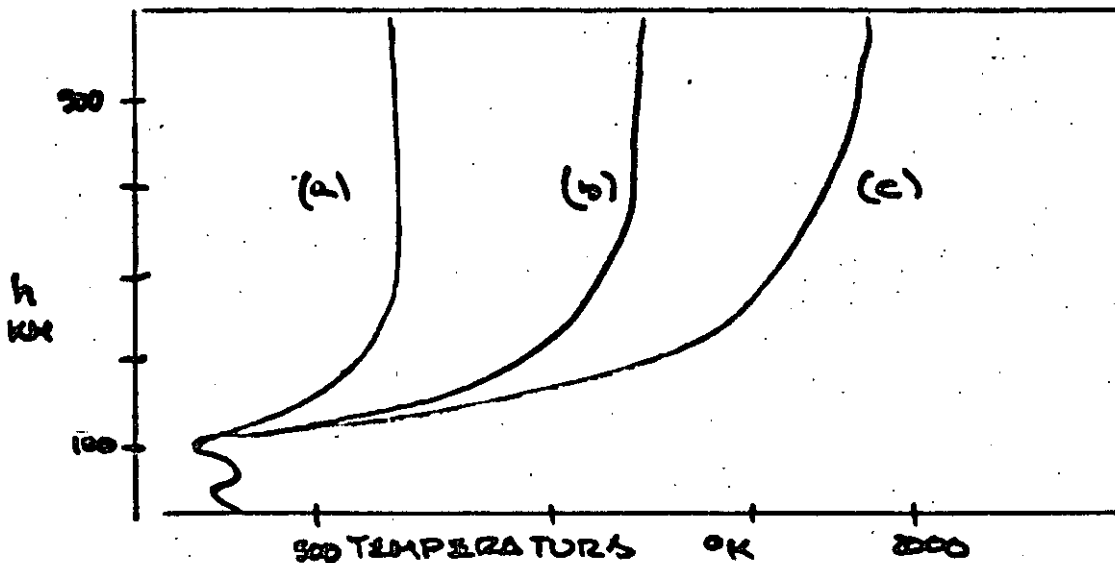
 $T < h, 50 < h < 85$

TERMÓSFERA

 $T < h, 85 < h$

} IONÓSFERA

EN LA TROPÓSFERA SE DESARROLLAN CASI TODOS LOS FENÓMENOS METEOROLÓGICOS.



(a) Atmosfera nocturna

(b) Atmosfera promedio

(c) Atmosfera diurna

VHF : Interferencia via ionosfera y las diferentes

UHF : Capas q' la forman D, E, F₁, F₂.

SHF : Pérdidas por difracción y dispersión, relativa atenuación por precipitación en la base d' la banda, pero importante en la media y alta.

EHF : Atenuación y absorción muy severas.

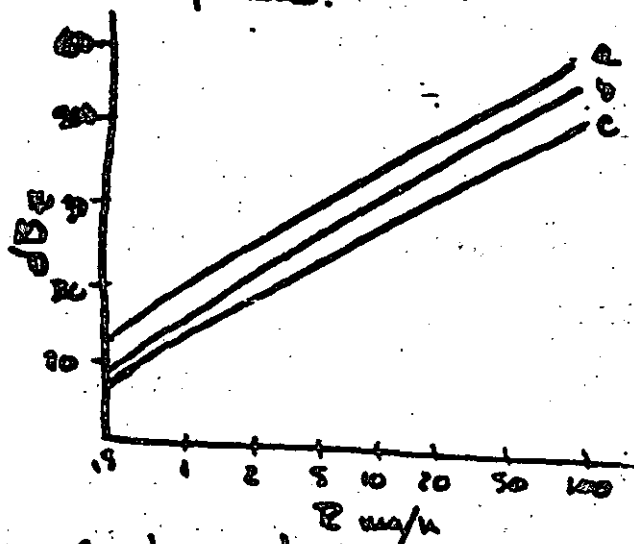
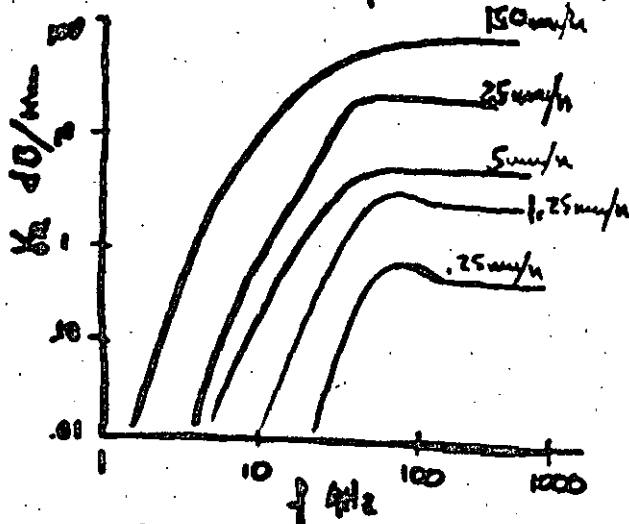
(3) Atenuació experimentada en un cable SST-TIE es el resultat d' la distribució d' la atenuació específica a través d' este cable.

dispersion: f (tamaño, numero, dist d' orientació, prop dielec, y distribució espacial).

modelos d' atenuació específica:
 Janssen and Parsons - $f \leq 40 \text{ GHz}$
 Marshall a Palmer - *climas templados continentals*

$$A = \int_0^R \gamma_a(r) dr \quad \gamma_a = K_e R^a \quad \delta B / \text{km}$$

$K_e \triangleq$ coeficiente d' atenuación específica $\delta B / \text{km} / \text{mm} / \text{h}$
 a ϵ depende d' la frecuencia, temp, y distribución d' gotas en tamaño.



$K_e = f$ (volumen total d' agua) Janssen Parsons

$z(\bar{a}) \triangleq$ fracción d' vol total / m^3 d' espacio con un radio \bar{a} a $\bar{a} + d\bar{a}$ medio

a: tormentas

b: llovizna

c: llovizna

$$z = a R^b$$

$$V(\bar{a}) = V_w z(\bar{a})$$

$V_w \triangleq$ vol tot d' agua / m^3 d' espacio

$V(\bar{a}) \triangleq$ vol d' agua / m^3 d' gotas con radio $\bar{a}, \bar{a} + d\bar{a}$

$$n(\bar{a}) = \frac{V(\bar{a})}{\frac{4}{3} \pi \bar{a}^3} \triangleq \# \text{ d' gotas} / \text{m}^3 \quad V_w \triangleq ?$$

de presencia d'hidrometeoros en la atmosfera inducen en l' OEM, atenuación diferencial y desfaseamiento diferencial: (4)

$$\Delta\alpha = (\alpha_1 - \alpha_2)_{0=0} \cos^2 \theta_e$$

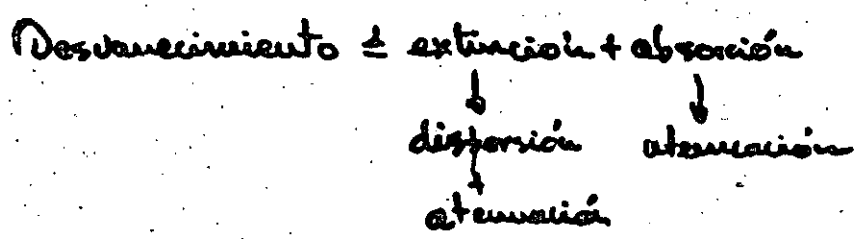
$$\Delta\beta = (\beta_1 - \beta_2)_{0=0} \cos^2 \theta_e$$

donde θ_e es el \angle d' elevación, q' tambien afecta nuestra trayectoria d' vuelo con el satélite. La proporcionalidad entre atenuación y desfaseamiento está dada por

$$\% \approx 4^{-1} [\sqrt{(\Delta\alpha)^2 + (\Delta\beta)^2} L]^2 \quad L \approx \text{longitud d' trayectoria.}$$

Cuando existen eventos con lluvia dominante $\Delta\beta \geq 0$, cuando los hidrometeoros son sólidos y $T < 5^\circ\text{C}$ $\Delta\alpha \leq 0$.

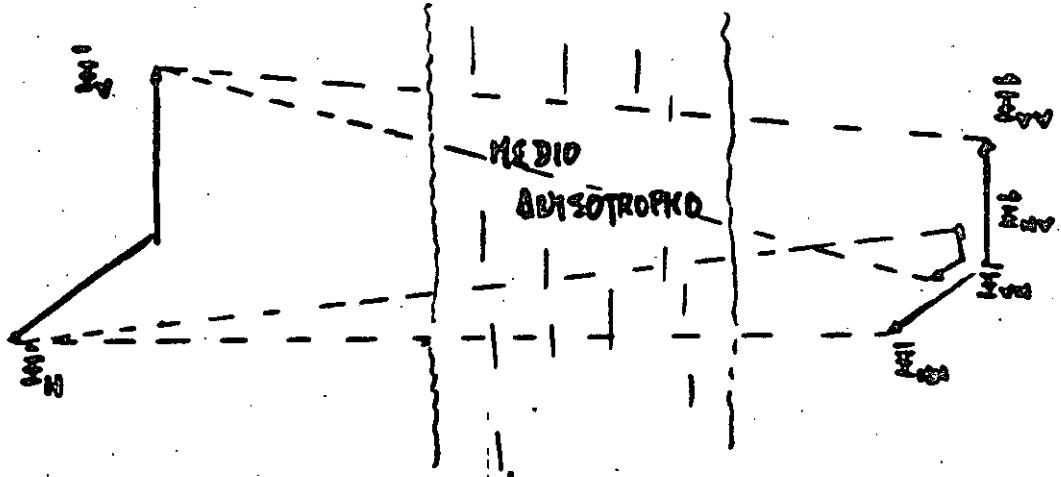
Estáticamente hablando, atenuación se usa únicamente para cuantificar los efectos del medio, sin antena. La medición de depolarización es usualmente dada por (XPD) cross polar discrimination, q' considera al medio solamente, substrayendo los efectos residuales, (efectos d' antena).



$F(r, s, t, \phi)$ d' desvanecimiento es una función aleatoria

- r \pm posición d' las partículas
- s \pm tamaño d' las partículas
- t \pm forma d' las partículas
- ϕ \pm orientación de las partículas.

Cuando se tx con polarización dual, se tiene:



depolarización $\pm \frac{E_r}{E_t}$ E_r y E_t \neq vector complejo d' campo \pm .
 Formas d' ondas depolarización \rightarrow desdoblamiento polar cruzada
 desdoblamiento

$$XPD = 20 \lg \left[\frac{|E_{Hv}|}{|E_{VH}|} \right]$$

$$I = 20 \lg \left[\frac{|E_{Hv}|}{|E_{VH}|} \right]$$

Cuando el receptor es casi ideal (lineal) $XPD = I$, y únicamente la contribución del medio produce depolarización, $E_{Hv} = E_{VH} = 0$

PROPAGACION TROPOSFERICA

La refractividad d' la atmosfera en la troposfera para radio-ondas está en función d' temperatura, presión, y contenido d' agua, dada por

$$N = 27.6 T^{-1} \left[p + \frac{4810 e}{T} \right] = (n-1) (10^6)$$

$$T = 288 - 6.5 h$$

esta refracción varía con l' altura la temperatura también varía con el tiempo.

La variación d' N con la altura puede producir reflexión y/o ducting d' OBM, N decrece con la altura, la aprox está dada

$$N(h) = N_s \exp[-h/h_0] \quad N_s \neq \text{valor d' N en la superficie.}$$

$$h_0 \neq \text{altura d' escala.}$$

CCIR define un valor promedio

$$N(h) = 315 \exp[-h/7.36] \quad \Delta N = -\Delta \exp[BN_s] = -40$$

$$2.1 < A < 9.3 \quad \wedge \quad 0.0045 < B < 0.0094$$

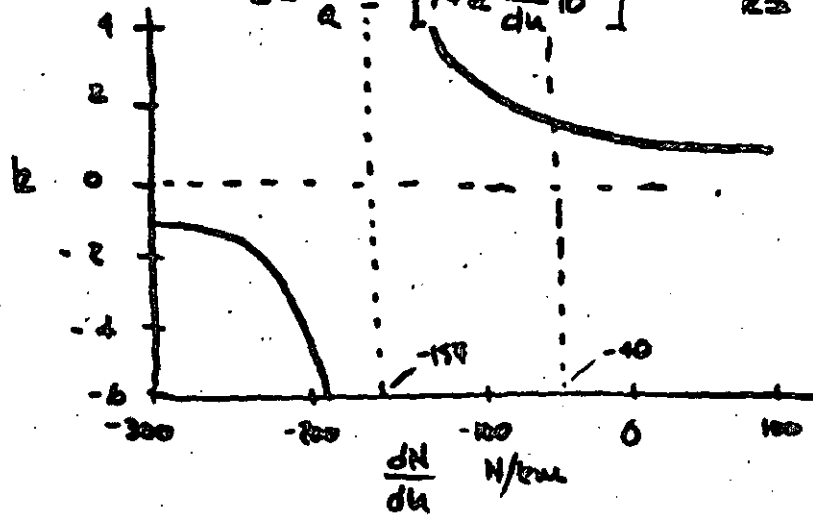
6

de variación d' índice d' refractividad en la atmosfera \Rightarrow OEM es propagación en línea recta, entonces $n(h)(h+a)\cos\theta = k$
 si tenemos un gradiente dn/dh , los rayos son refractados hacia la región d' refractividad mayor con radio d' curvatura r , así

$$r^{-1} = -n^{-1} \frac{dn}{dh} \cos\theta$$

Considerando el radio efectivo d' la tierra y el radio verdadero, tenemos una relación

$$k = \frac{a_0}{a} = \left[1 + a \frac{dn}{dh} 10^{-6} \right]^{-1} \quad k \approx \frac{4}{3} \vee a_0 = 1500 \text{ km}$$



En la gráfica superior tenemos los sigtes casos:

Región ducting)
 $dn/dh < -157$
 $k < 0$
 $a_0 < 0$

Región Superrefracción
 $-157 < dn/dh < -40$
 $0 < k < 4/3$
 $0 < a_0$

Región Subrefracción
 $-40 < dn/dh$
 $4/3 < k < 0$
 $0 < a_0$

Debido a la refracción se requiere una corrección en θ d' elevación E en los enlaces via satélite, evitando así ducting, la memoria d' ondas q' quedan atrapadas están en SHF y muy rara la vez en VHF.

$$\lambda_{max} = (2.5)(10^3) \left[\frac{dn}{dh} - 0.157 \right]^{1/2} f^{3/2}$$

PROPAGACION IONOSFERICA

Ionosfera es un plasma q' se encuentra entre 60 a 500 Km, el medio se ioniza por la radiación solar en el rango ultravioleta y rayos X, el plasma contiene electrones libres y iones positivos, una fracción del plasma está ionizado. La producción d' electrones se lleva a cabo en la región E y F por fotoionización, la foto-reparación es significativa en la noche en la región D.

La región E está entre 90 a 140 Km con concentración d' $10^5/\text{cm}^3$ tiene alta conductividad eléctrica, los efectos geomagnéticos son muy apreciables.

Las ondas d'la banda HF se reflejan en esta region, pudiendose emplear para COM'S. La region F se subdivide en F₁ y F₂, F₂ es altamente utilizable para COM'S, tiene una densidad aprox 5(10⁸) a 2(10⁶)/cm³ a una altura 200-400 KM, en la uode F₁ tiende a desaparecer.

Se puede demostrar q' las ondas q' pueden propagarse perpendicularmente a un campo aplicado en un plasma estan polarizadas circularmente, las ondas polarizadas linealmente no son ondas caracteristicas y su polarizacion cambia cuando se propagan, la direccion d'la intensidad d' campo \vec{E} rota y constituye un cambio d' polarizacion. Consideremos una onda LP propagandose en direccion z teniendo componente x

$$\vec{E}(z) = \hat{a}_x E_m e^{ikz}$$

a tiempo t

$$\vec{E}(z) \exp(j\omega t) = \hat{a}_x \exp(j\omega t) E_m e^{-jkz}$$

en el origen

$$\vec{E}(z, t) = \hat{a}_x E_m \cos(\omega t - kz)$$

descomponiendo

$$\vec{E}(z, t) = \hat{a}_x E_m \cos(\omega t - kz)$$

$$\begin{aligned} \vec{E}(z, t) &= |E_L| \exp(-j\omega t) + |E_R| \exp(+j\omega t) \\ &= \exp(+j\omega t) [|E_L| + |E_R|] \end{aligned}$$

en posicion z

$$\vec{E}(z, t) = |E_L| \exp[-j(\omega t - k_L z)] + |E_R| \exp[j(\omega t - k_R z)]$$

las constantes d' propagacion k_L y k_R se determinan asi;

$$u_1 = \sqrt{\mu_1} \quad k_L = k_0 u_1 \quad k_R = 2\pi/\lambda_0 \quad \lambda_0 = \frac{c}{f}$$

uicilmente, mas se alejamos d'la fuente en direccion d'la propagacion, mayor es el retardo para el termino E_R, a t=0 tenemos

$$\vec{E}(z, 0) = E_L \exp[jk_L z] + E_R \exp[-jk_R z]$$

Supongamos k_Lz = 80° y k_Rz = 40° k_Rz < k_Lz

$$(k_L z - k_R z)/2 = \phi = 20^\circ$$

φ es el ángulo d' rotacion d' \vec{E} , en direccion circular derecha.

a frecuencias suficientemente altas:

$$(k_L - k_R)/2 \approx k_0 (\omega \sqrt{\epsilon} / \omega^2) (\omega \epsilon / \omega) / 2$$

el incremento d' rotacion dφ en longitud dz ⇒ dφ ≈ $\frac{\pi}{\lambda_0} xy dz$

$$\frac{\pi}{\lambda_0} (xy) = \frac{\pi N_0 e^3}{2c \epsilon_0 m^2 \omega^2} \quad \text{entonces} \quad \phi = 2.36 (\omega^4) t^2 \int N_0 dz$$

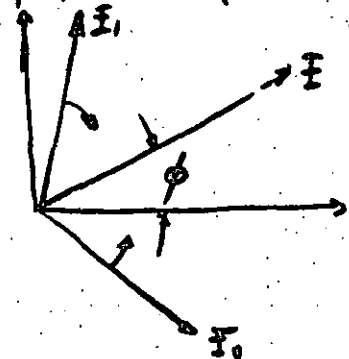
N₀ es concentración d' particulas

ε₀ es permitividad ideal

m es masa d' particula

f es frecuencia d' OEH → ω = 2πf

E es campo magnetico aplicado.



Ventilación

Los efectos mayores se aprecian en frecuencias cercanas a 157 MHz y en las regiones ecuatoriales y cercanas, con mayor incidencia durante la noche.

En enlace vía satélite, este fenómeno ocurre cuando el ϕ d'elevación es $< 10^\circ$ y a frecuencias < 10 GHz. La causa principal es el cambio d'N en la atmósfera, ocasionando una pérdida d'señal en tiempos muy cortos, esto debido a pérdida por desacoplamiento entre la antena y la señal, sufriendo una degradación en la ganancia. Se ha detectado una relación entre la desviación estándar d'la potencia en función d'l ϕ d'elevación, donde $5 < \alpha < 20^\circ$

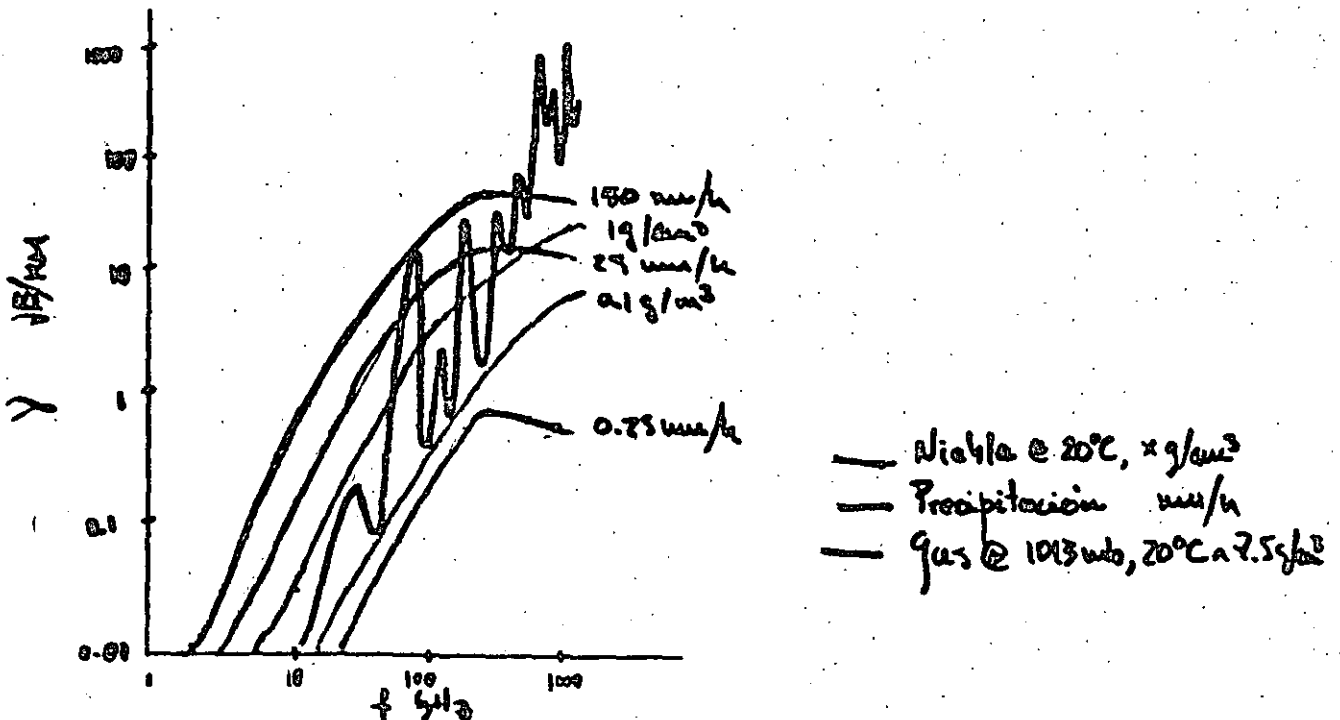
$$\sigma = 6.5 \alpha d^{-1.5} \text{ dB} \quad d \text{ es } \phi \text{ d'antena. } \therefore 20 < \phi < 40 \text{ m}$$

En 20B, existe una relación experimental desarrollada para $15 < \alpha < 20^\circ$ y $4 \leq f < 30$ GHz, donde la ventilación pico-a-pico está dada por:

$$C_{pp} = 0.5 (\sin \alpha)^{-1} \text{ dB}$$

experimentando a 6 GHz se han encontrado pendientes d' bajada en la señal mayores a 1 dB/s al 1% d'l tiempo y 4 dB/s al 4%, esta información es necesaria para el diseño d'los transponders en los accesos múltiples d'varios ST.

Ventilación ionosférica es importante cuando $f < 6$ GHz, en las mismas regiones mencionadas anteriormente, a partir d' $f = 100$ MHz. En la banda VHF se han observado por tiempo d'varios minutos, y en SHF por varios segundos.



ENLACES Y SERVICIOS

VHF : Difusión d' TV y Sonido, aeronavegación, navegación aeromarina, amateur

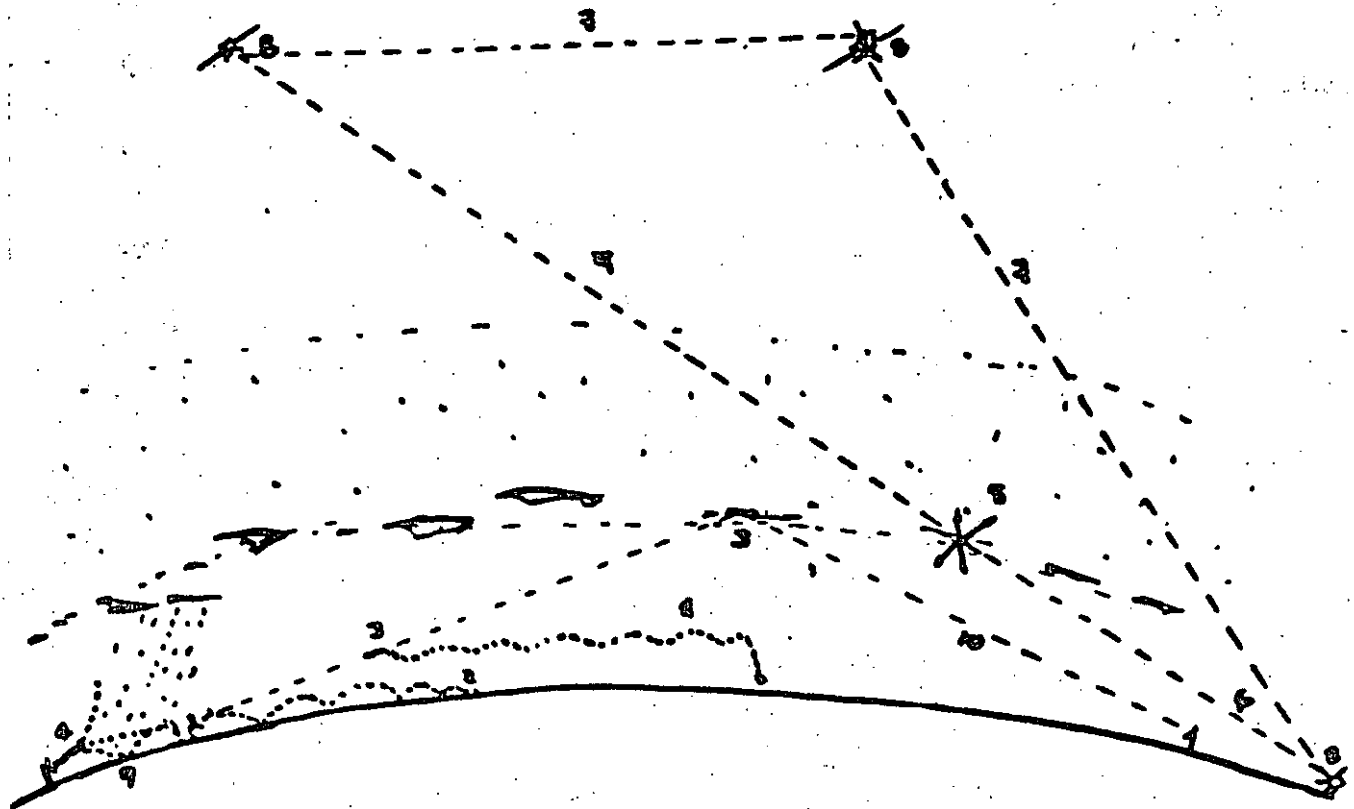
UHF : ie. Radar, Radio astronomía, COM ESPECIALES, radio amateur

SHF : Radar, SSTCOM, TX Datos, radio mobile, difusión via Satélite.

EHF : ie. Comunicación intersatélite, navegación, TX Datos

Banda 12: Experimental $\lambda \leq 1 \text{ mm}$

Banda 13: Experimental y COM OPTICAS $\lambda \leq .1 \text{ mm}$



1. Ducting
2. Ducting
3. Reflexión
4. Refracción
5. Difracción
6. Atenuación

7. Línea recta
8. Bloqueado por equipo no lineal
9. Difracción
10. Bloqueado

EFFECTOS ATMOSFERICOS

Esta parte trata con varios efectos de propagación que influyen el desempeño de sistemas de comunicación vía satélite. Para bajas frecuencias (100 MHz - 4 GHz), la cintilación ionosférica es un verdadero problema. El fenómeno troposférico, tal como absorción molecular, atenuación por lluvia y dispersión debe también considerarse para frecuencias arriba de 4 GHz. El efecto dominante arriba de 4 GHz es la atenuación debida a lluvia. Las otras degradaciones causadas por lluvia, tal como depolarización, interferencia entre sistemas debido a dispersión, aumento en el ruido de las estaciones terrenas y degradación en el desempeño de la antena de la estación terrena, también son discutidas aquí.

Conforme los sistemas de satélites utilizan mayores frecuencias y usan más sofisticados sistemas de procesamiento de señales, será importante tener un adecuado desarrollo en el campo de la propagación tanto teórico como experimental.

CINTILACION IONOSFERICA.

Las primeras observaciones en esta área revelaron que las señales de radio, frecuentemente presentaban fluctuaciones en intensidad, las cuales eran causadas por irregularidades ionosféricas y subsecuentemente, tales fluctuaciones venidas de fuentes estelares y de satélites fueron estudiadas extensivamente. Estas fluctuaciones de amplitud, fase y ángulo de arribo, comúnmente llamada cintilación ionosférica, han sido observadas a frecuencias entre 10 MHz y 6GHz.

E F E C T O S D E P R O P A G A C I O N**- C I N T I L A C I O N I O N O S F E R I C A**

Oxígeno y vapor de agua

Lluvia

Niebla y Nubes

- A B S O R C I O N A T M O S F E R I C A

Nieve y Granizo

Electrones libres en la
atmósfera.

- D E P O L A R I Z A C I O N D E B I D O A L L U V I A**- P R O T E C C I O N D E E S T A C I O N E S T E R R E N A S (R A D O M E) .**

La cintilación depende de varios factores tales como localización geográfica, frecuencia, trayectoria de propagación, condiciones geofísicas y la medida usada para describir la cintilación. Estas fluctuaciones son realmente producidas por pequeñas irregularidades en la densidad de electrones en la capa F de la ionósfera. Recientes mediciones han motivado esta situación en altas y ecuatoriales altitudes. Existe una región irregular a latitudes altas cuya frontera baja alcanza 57° cerca de la media noche. Durante tormentas magnéticas la frontera desciende a latitudes más bajas y el desvanecimiento es mayor.

Las irregularidades producen cintilaciones profundas en el rango de VHF a $\pm 15^\circ$ del Ecuador. Para minimizar el efecto de este fenómeno en transmisiones de satélites, el diseñador del sistema puede utilizar las distribuciones de amplitud, razones de desvanecimiento y profundidad al diseñar la modulación.

Por ejemplo, a 137 MHz la cintilación con desvanecimiento arriba de 6dB ocurren en las trayectorias del Zenith en menos del 20% del tiempo cerca del Ecuador, menos del 2% en las regiones aurales y menos de 0.1% en latitudes medias.

Observaciones experimentales de cintilaciones fueron realizadas en Millstone usando fase coherente a 150 y 400 MHz del sistema de satélites naval de los Estados Unidos (NNSS) y receptores en las facilidades de Millstone Hill. Un ejemplo de fluctuaciones de nivel de la señal recibida y de la fase diferencial (variación de fase a 150 MHz relativa a la referencia de fase de 400 MHz) para un segmento de 1 min. se da en la Fig. 29 .

Para este segmento de datos, los valores de σ_x fueron 1.27 dB en UHF y 5.50 en VHF.

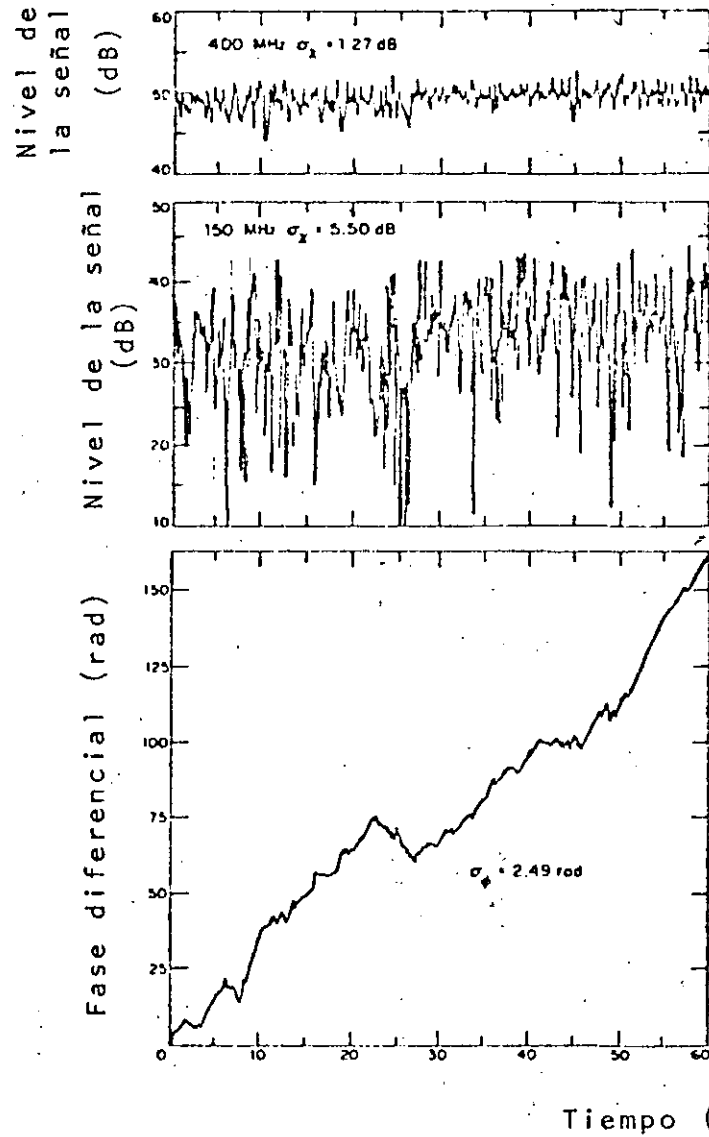


Fig. 29 Nivel de la señal y fluctuaciones de fase para un intervalo de observación de 1 min.

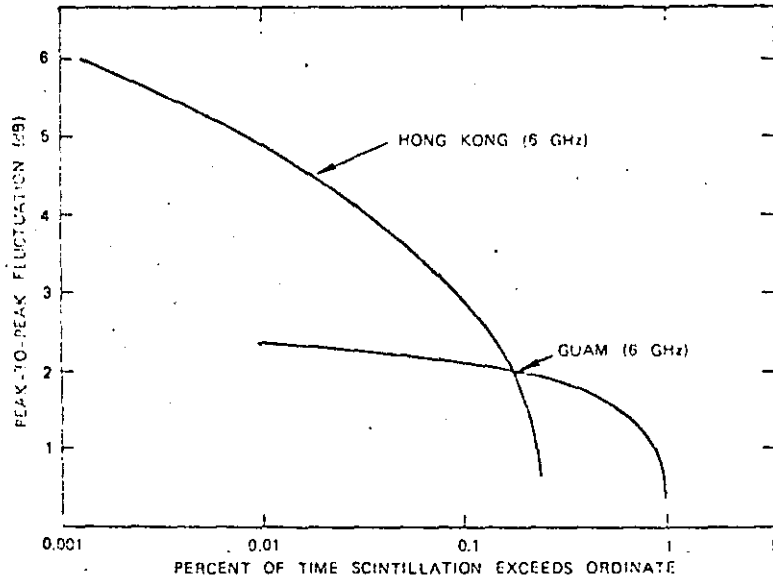


Figure 5. Cumulative Amplitude Distributions at Guam (6 GHz) and Hong Kong (6 GHz)

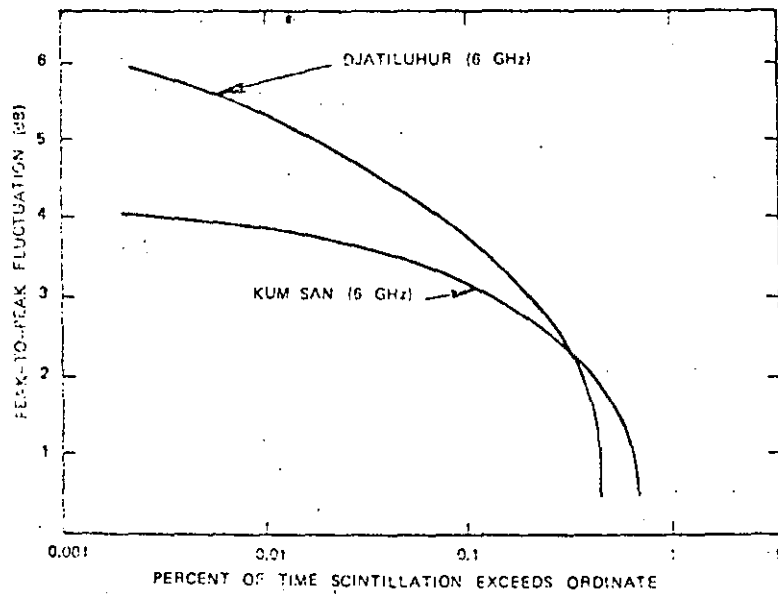


Figure 6. Cumulative Amplitude Distributions at Djatiluhur (6 GHz) and Kum San (6 GHz)

ABSORCION ATMOSFERICA

- OXIGENO MOLECULAR
- VAPOR DE AGUA
- LLUVIA
- NIEBLA Y NUBES
- NIEVE Y GRANIZO
- ELECTRONES LIBRES EN LA ATMOSFERA

OXIGENO MOLECULAR, VAPOR DE AGUA Y ELECTRONES.

El oxígeno molecular y el vapor de agua son relativamente constantes. Las Figs. 30 y 31 muestran la absorción debida al oxígeno y al vapor de agua. La absorción es mayor para grandes ángulos de elevación, debido a que el haz recorre mayores trayectorias a través de la atmósfera.

La absorción por oxígeno molecular tiene un pico a 60 GHz, y la absorción por moléculas de agua tiene un pico a 21GHz. La absorción es causada por la onda de radio que cambia los niveles de energía rotacional de las moléculas, y los efectos de resonancia ocurren a esas frecuencias. Cuando hay electrones libres en la atmósfera de la Tierra las ondas de radio chocan con ellos. Esto causa absorción debido a que la energía de radio se transfiere a los electrones. La densidad de electrones de la ionósfera se reduce grandemente durante las horas de la noche. Los principales efectos por absorción de electrones son a frecuencias abajo de 100 MHz y tiene efectos despreciables en las bandas UHF y SHF.

La Fig. 32 muestra un diagrama de la absorción causada por electrones, oxígeno y vapor de agua.

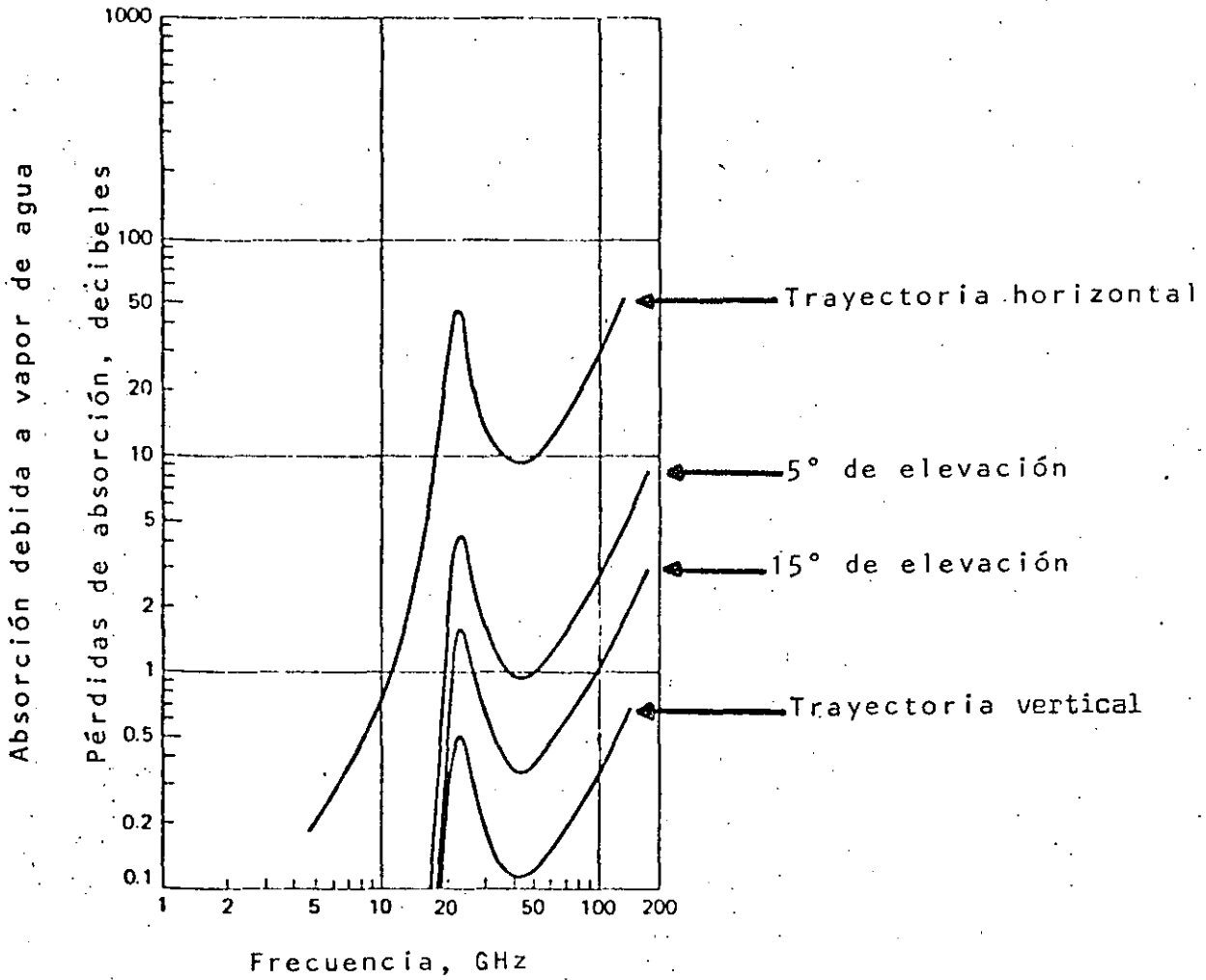


Fig. 30 Absorción en la atmósfera causada por vapor de agua sin condensar.

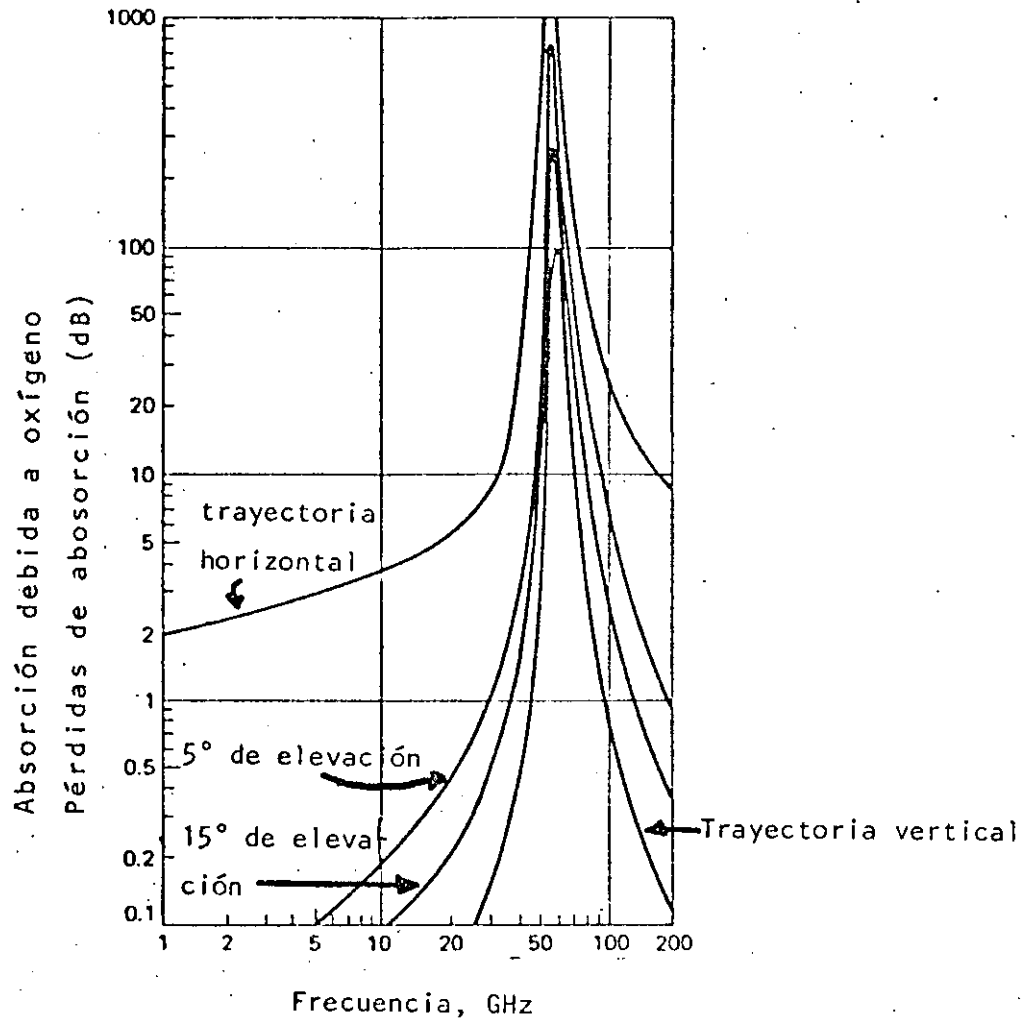


Fig. 31 Absorción molecular.

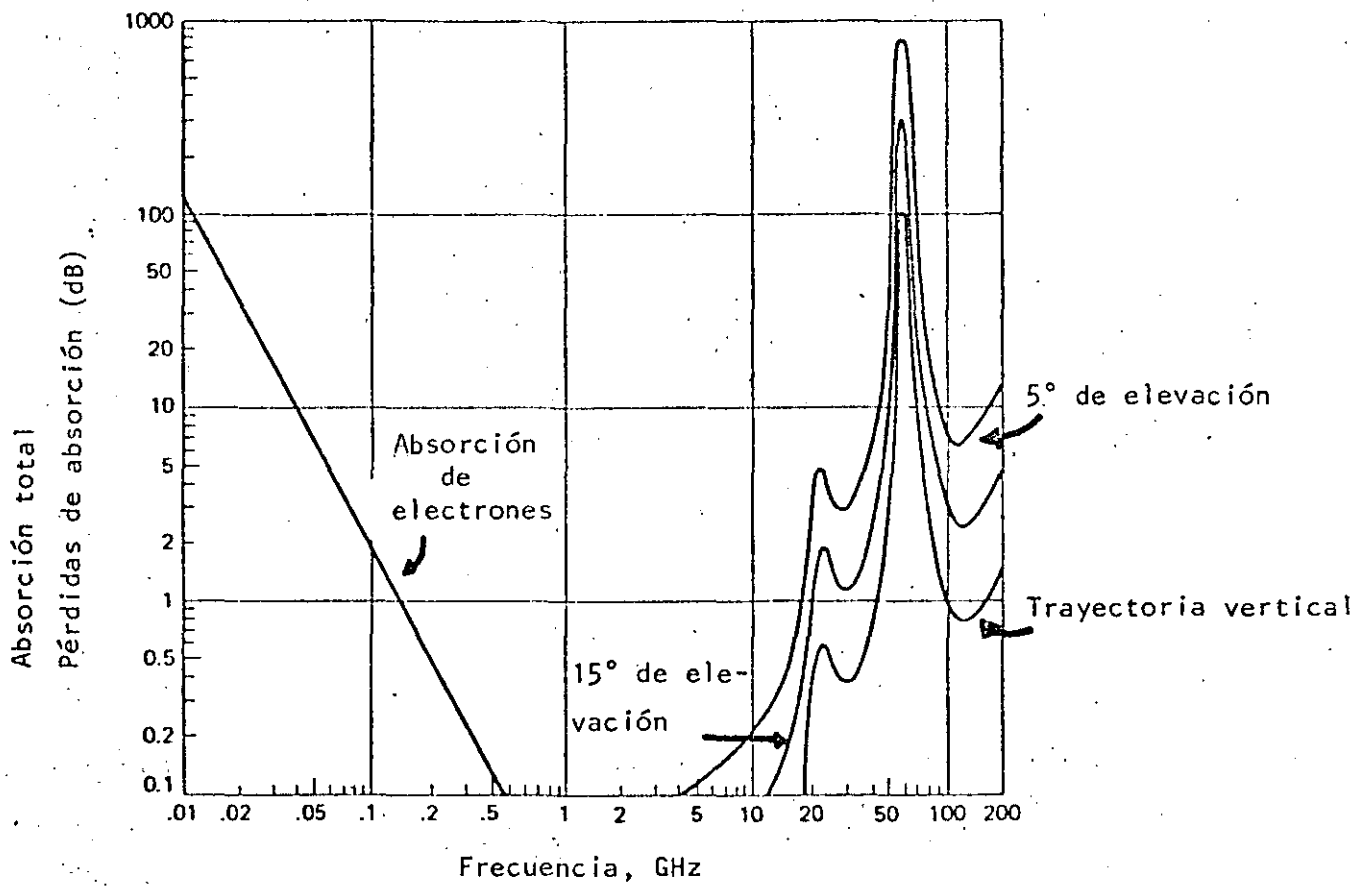
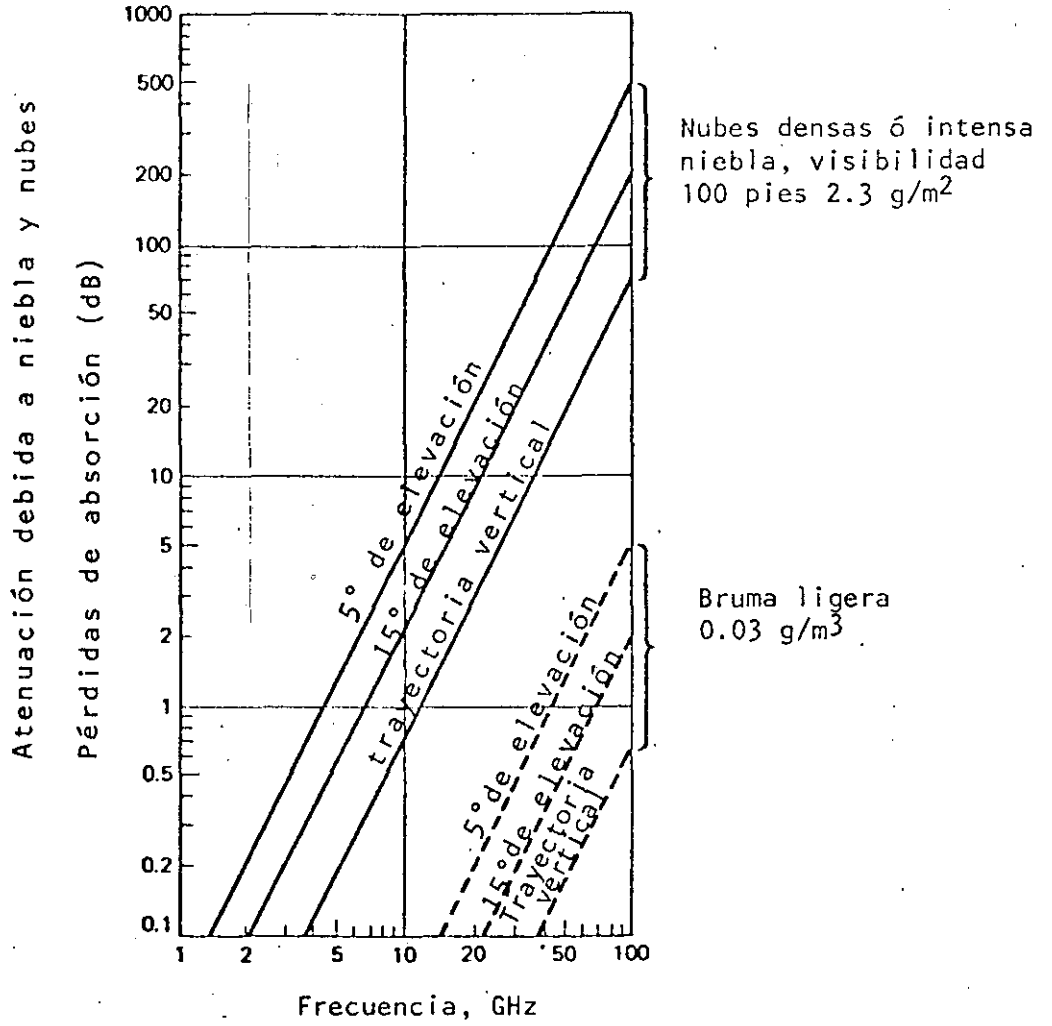


Fig. 32 Absorción en la atmósfera causada por electrones, oxígeno molecular y vapor de agua sin condensar.



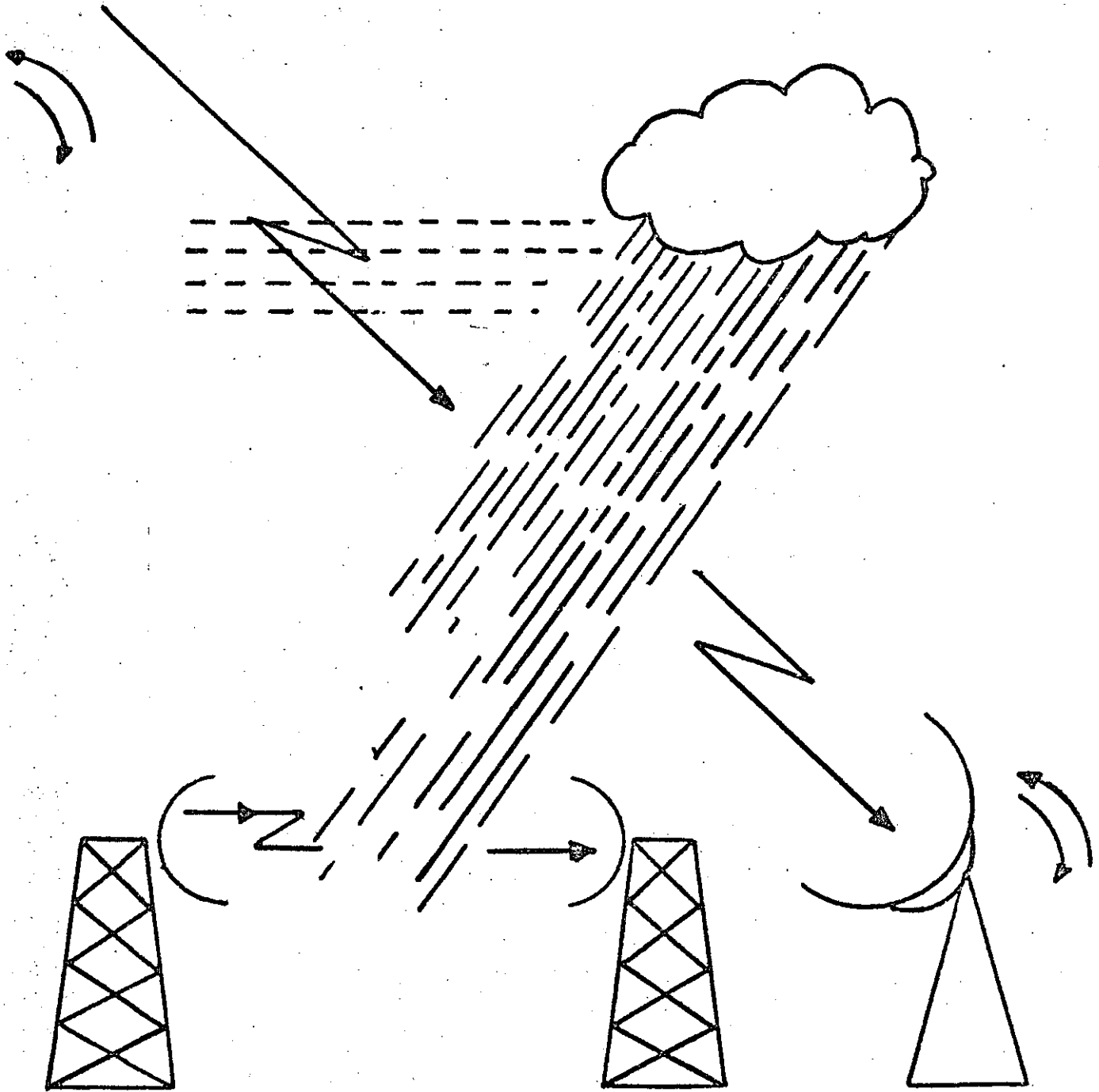
Típica absorción debida a niebla, bruma y nubes.

EFECTOS DE LA LLUVIA.

El mayor obstáculo encontrado en el diseño de sistemas de comunicación vía satélite a frecuencias arriba de 10 GHz es la atenuación por lluvia. La potencia de microondas radiada hacia una estación terrena, limitada por factores, tales como la potencia primaria disponible y el tamaño de la antena en el satélite, es insuficiente con la tecnología presente para contrarrestar la atenuación tan grande producida por intensa lluvia. Otras degradaciones producidas por lluvia, tales como depolarización, interferencia, aumento en el ruido de la estación terrena y deterioro en el desempeño de la estación terrena, se discuten también en esta parte.

Actualmente, las frecuencias de 4 y 6 GHz para satélites de comunicaciones son algo muy común de utilizarse, siendo importante tener cuidado en la calidad de las antenas de las estaciones terrenas, así como en la selección de sitios para evitar interferencia con los sistemas terrestres que comparten en estas mismas bandas de frecuencias. Sin embargo, la saturación a estas frecuencias es ya un hecho. Más aún, el ancho de banda designado a estas frecuencias es de 500 MHz, el cual se puede agotar muy pronto con el incremento de la demanda telefónica, de televisión y de datos. Para contrarrestar esta saturación, se propuso el uso de bandas de mayor frecuencia mayores de 2 GHz, tales como 19 y 29 GHz. Desafortunadamente, la lluvia es un factor mucho más serio a estas frecuencias que a 4 y 6 GHz y recientemente ha habido muchas reuniones internacionales sobre este asunto.

Antes de entrar a los detalles de los diversos efectos que tiene la lluvia en la propagación, deben recordarse



cuatro aspectos también a considerar: la nieve, la niebla, la tropósfera y la ionósfera. Cuando el agua se congela, como en el caso de las partículas en muchas nubes, la resonancia ocurre a longitudes de onda mayores. El resultado neto es que hielo y nieve seca presenta muy bajas pérdidas en la banda de microondas y por lo tanto no se considerará más en esta discusión.

Por otro lado, la niebla está, de seguro compuesta de pequeñas gotas, pero la densidad de agua líquida en intensa niebla es menos que $\frac{1}{20}$ con respecto a intensa lluvia tal que las atenuaciones encontradas son pequeñas y aquí serán despreciadas. Otro efecto de propagación, muy familiar para aquellos concernientes con sistemas terrestres, es el desvanecimiento de la señal causado por capas y otras aberraciones del contorno de refractividad de la tropósfera. Estas atenuaciones de la señal ocurren sobre haces de microondas que son esencialmente horizontales, interactuando de este modo a ángulos de rozamiento cercano con las capas. Pero para trayectorias típicas Tierra-satélite a ángulos de elevación de algunos grados, este tipo de desvanecimiento no es significativo y no será discutido en detalle. Las trayectorias Tierra-satélite que operan a las frecuencias bajas en la banda de microondas, es decir a 4 GHz están sujetas a alguna rotación de polarización por la ionósfera vía el efecto de Faraday.

ATENUACION POR LLUVIA.

El decremento en la magnitud S del vector de Poynting al pasar a través de una capa de precipitación de grueso Δl es

$$-\Delta S = S \Delta l \int_0^{\infty} n(a) Q(a, \lambda) da$$

donde $Q(a, \lambda)$ es la sección transversal de extinción (centímetros cuadrados) de una gota esférica con radio a (centímetros) y $n(a)da$ es el número de gotas por unidad de volumen (metros cúbicos) en el rango da . Integrando (1) se obtiene

$$S = S_0 \exp \left(- \int \alpha \, dl \right)$$

donde

$$\alpha = \int_0^{\infty} n(a) \cdot Q(a, \lambda) \, da$$

la atenuación en decibeles por kilometros es simplemente 0.434α con los parámetros dados en las unidades indicadas anteriormente. Las secciones transversales de extinción Q pueden calcularse usando la solución de dispersión de Mie para esferas y los índices de refracción de agua líquida medidos por Saxton. En el cálculo de atenuación se utilizan las distribuciones de Law y Parson. Durante la segunda guerra mundial Ryde y Ryde llevaron a cabo cálculos de atenuación por lluvia en el rango de microondas, esto ha sido extendido por otros con la ayuda de computadoras modernas. Estos datos son mostrados en la Fig. 33.

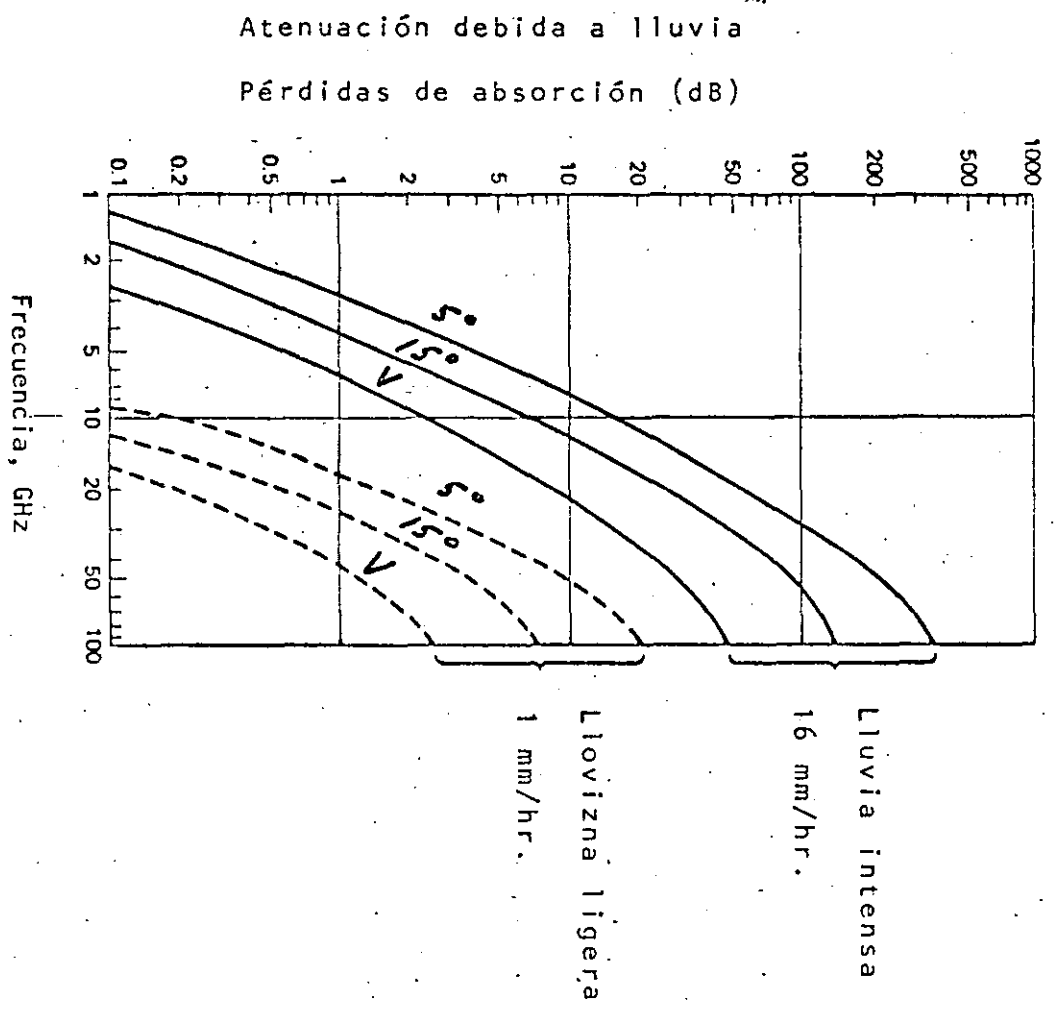
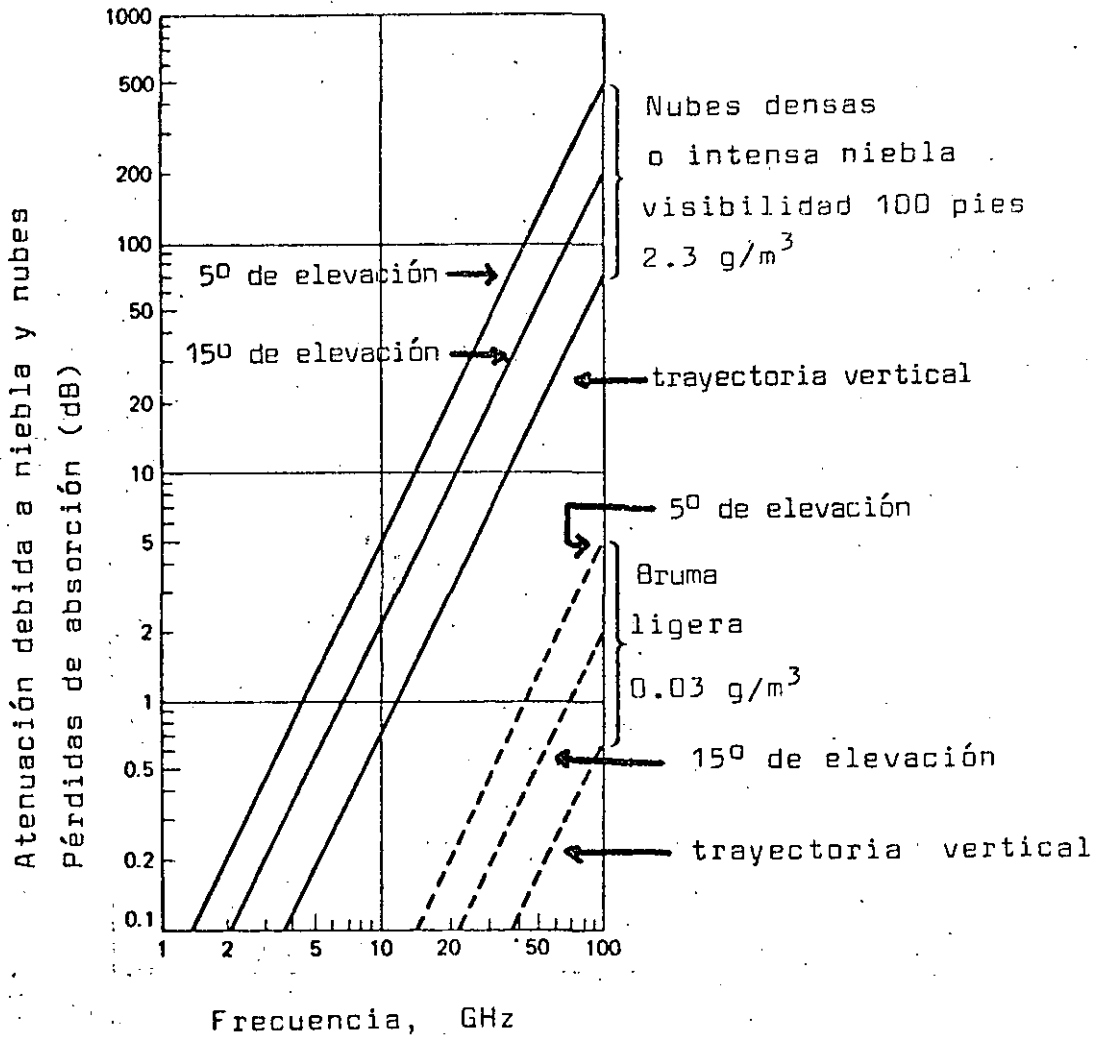


Fig. 33 Absorción típica debida a lluvia.



Típica absorción debida a niebla, bruma y nubes

ATENUACION DEPENDIENTE DE LA POLARIZACION Y LA DEPOLARIZACION.

La consideración de formas de gotas esféricas usada en el cálculo de Mie discutido en la sección anterior es solamente una aproximación de primer orden. Examinación por fotografías revelan que muchas de las grandes gotas son mejor representadas por esferoides achatados por los polos. --- Oguchi fué el primero en investigar el efecto de estas gotas en propagación de microondas usando cálculos de perturbación. La atenuación inducida por lluvia y el defasamiento obtenido son:

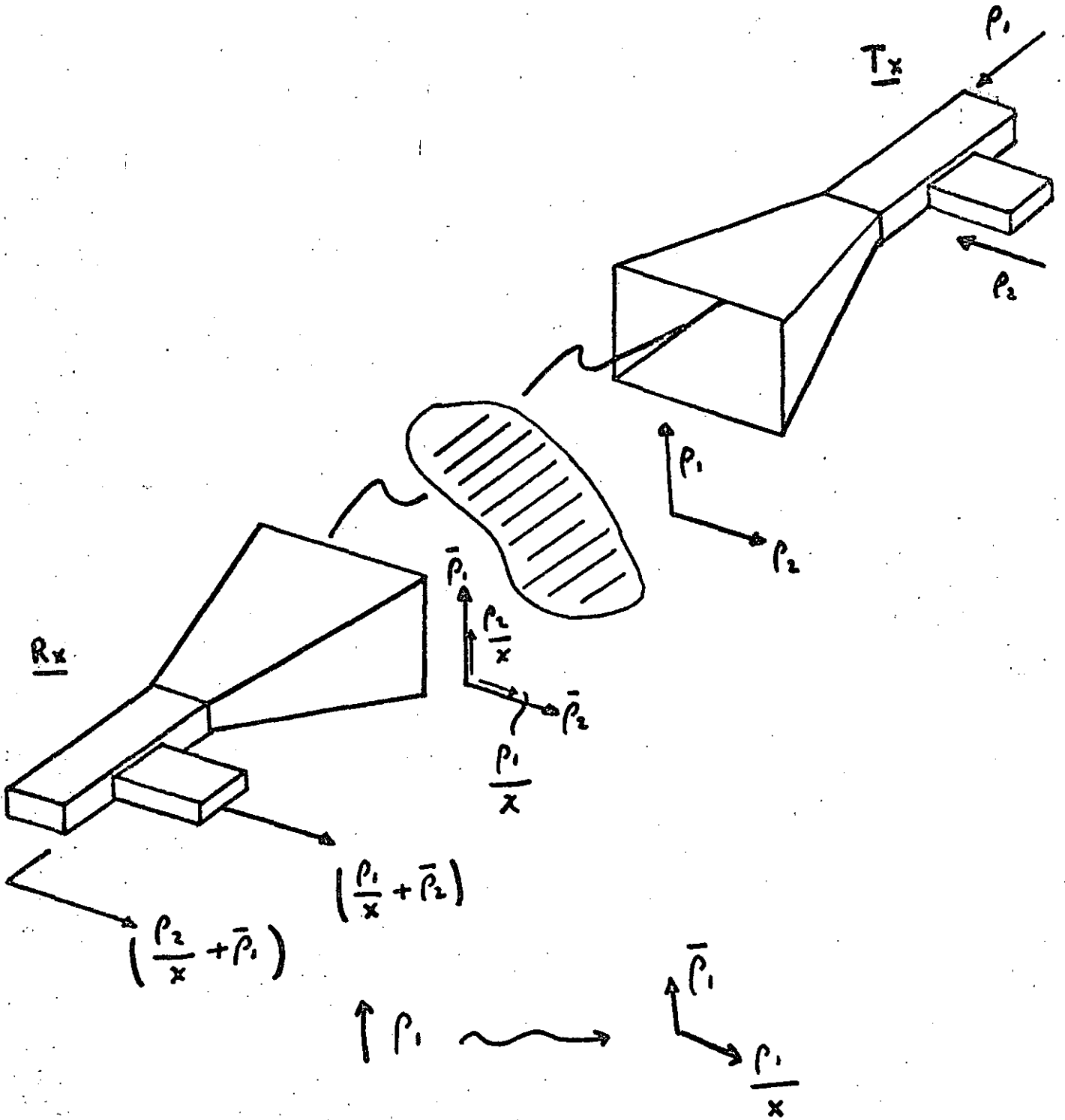
$$A_{I,II} = 0.434 \frac{\lambda^2}{\pi} \sum \operatorname{Re} S_{I,II}(o) n(\bar{a}) \text{ dB/km.}$$

$$\phi_{I,II} = -36 \frac{\lambda^2}{\pi} \sum \operatorname{Im} S_{I,II}(o) n(\bar{a}) \text{ gr/km.}$$

donde $n(\bar{a})$ es el número de gotas con radio esférico de igual volumen \bar{a} por metro cúbico, los índices I y II designan los campos eléctricos paralelos y perpendiculares a los planos que contienen los ejes de simetría de las gotas y la dirección de propagación de la onda incidente y la sumatoria es tomada sobre todos los tamaños de las gotas.

La atenuación y fase diferencial entre las polarizaciones II y I para varios valores de precipitación y frecuencias entre 4 y 100 GHz se muestran en la Fig. 34.

La depolarización por gotas inclinadas es un resultado -- tanto de la atenuación diferencial como del defasamiento entre los componentes de las polarizaciones I y II. La



$$x P D = \frac{P_1}{x} / P_1$$

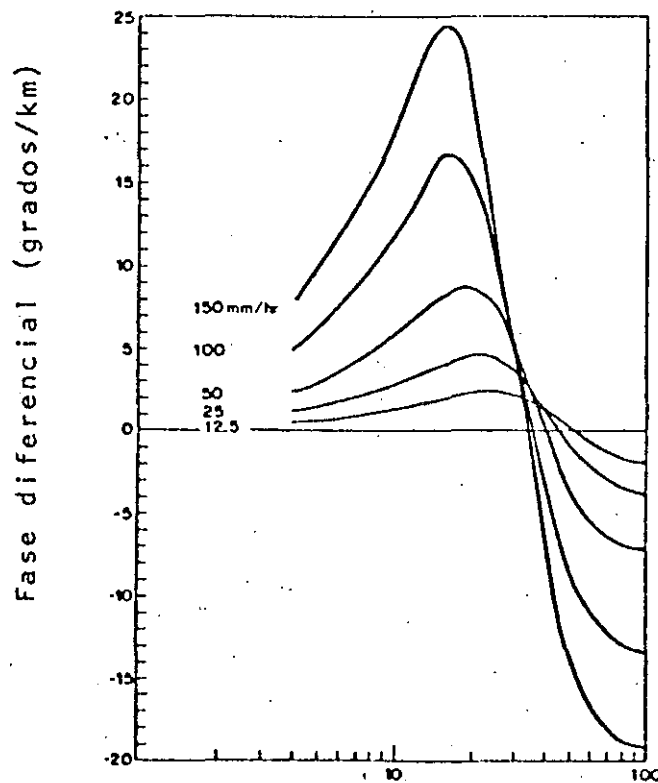
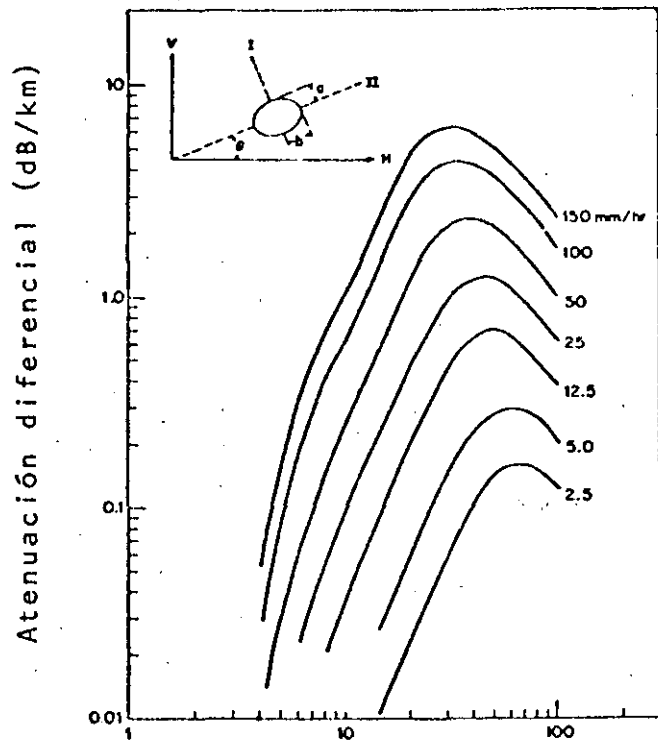


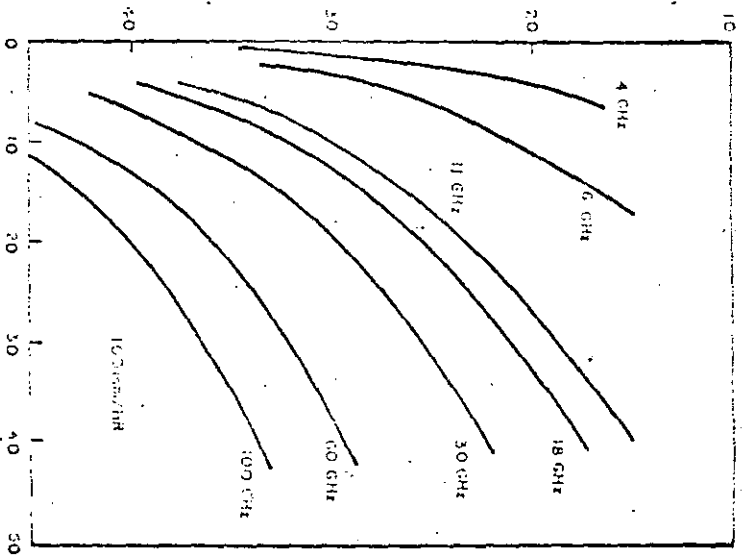
Fig. 34 Atenuación y fase diferencial entre polarizaciones I y II para varias intensidades de precipitación.

discriminación de polarización cruzada, medida para polarización horizontal a 11, 17.71 y 60 GHz se grafica en la Fig. 35.

Debido a que la atenuación por lluvia para polarización vertical es menor que para horizontal, la discriminación de polarización cruzada a una atenuación dada para una polarización vertical es mejor que para polarización horizontal, como ha sido confirmado experimentalmente. La discriminación medida de una onda polarizada linealmente orientada a 45° con respecto a la dirección vertical y de una onda polarizada circularmente, se ha encontrado que es muy severa como se muestra en la Fig. 36.

Predicciones teóricas de polarización cruzada inducida por lluvia se ven impedidas por incertidumbre en la distribución del ángulo de inclinación de las gotas. Se encontró por medio de fotografías de gotas de lluvia que el ángulo de inclinación no está lejos de una distribución igual a la dirección vertical (gravedad). En el caso de una onda polarizada horizontal o verticalmente, la polarización cruzada producida por ángulos de inclinación positivos o negativos tiende a cancelarse. Pero se ha encontrado que predicciones sistemáticas pueden obtenerse al comparar atenuaciones diferenciales medidas y polarizaciones cruzadas a una frecuencia, con valores calculados, para determinar dos parámetros empíricos: Un promedio efectivo del valor absoluto del ángulo de inclinación y el desequilibrio en el número de gotas con ángulos de inclinación positivos y negativos. Tales medios empíricos se muestran en la Fig. 37 para la polarización cruzada de ondas polarizadas horizontalmente a varias frecuencias. Comparando las Figs. 35 y 37 se muestra una clara concordancia para frecuencias abajo de 30 GHz.

Discriminación de polarización
cruzada media en (db)



Atenuación en polarización hori-
zontal en dB.

Fig. 37.

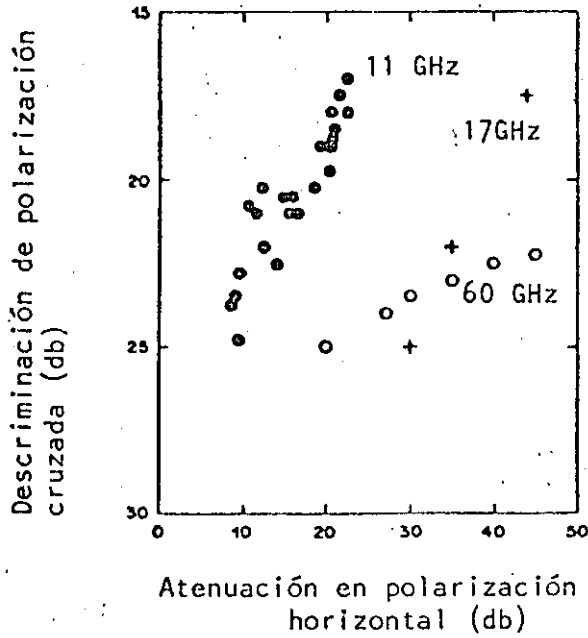


Fig. 35 Polarización cruzada inducida por lluvia para polarización horizontal.

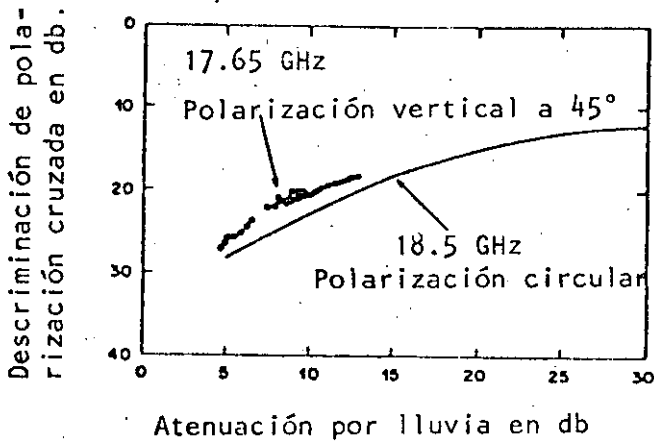


Fig. 36 Depolarización medida contra atenuación para polarización circular y polarización lineal a 45°.

DEGRADACION DEL RENDIMIENTO DE LA ANTENA POR LLUVIA.

Un análisis de la caída de lluvia sobre una cubierta (Radome) hemisférica, mostró que se forma una capa de lluvia de espesor constante sobre la cubierta. Una onda electromagnética que incide sobre una capa de agua, experimenta tanto pérdidas de absorción como de reflexión, la degradación total resultante en la transmisión se muestra en la Fig. 38, como una función del espesor para muchas frecuencias de interés. Por ejemplo a 18.5 GHz, se introduce una atenuación de 10 dB para una capa de agua de un cuarto de milímetro de espesor. Por lo tanto si capas de ese espesor se forman por la caída de lluvia en una cubierta, el diseñador del sistema se encuentra con otra atenuación del mismo orden que la producida por lluvia en la trayectoria de propagación. Desafortunadamente, se sabe poco respecto al espesor de las capas formadas para un dado índice de lluvia, ya que depende de la geometría y las propiedades de fricción y humedad de la superficie. Si no se coloca la cubierta en la antena, se introduce pequeña atenuación por las capas de lluvia en la superficie reflectora en cambio lluvia y nieve producen polarización cruzada.

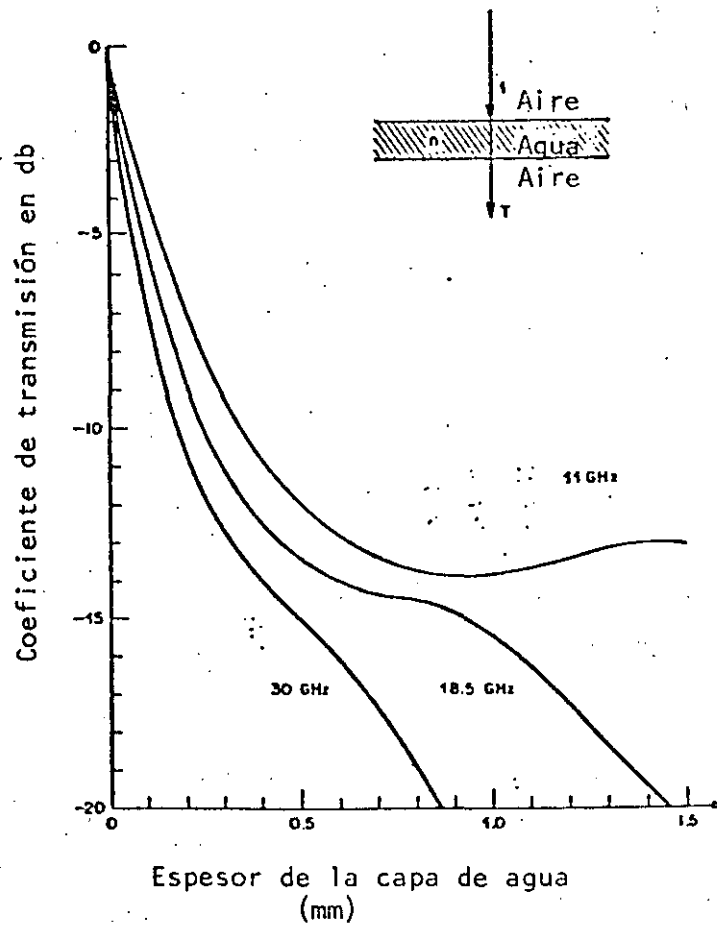


Fig. 38

RUIDO.

76

Temperatura de Ruido. La potencia de ruido es usualmente cuantificada en términos de su temperatura de ruido. Si el equipo electrónico estuviera perfectamente aislado de interferencias externas, de todos modos habría ruido en dicho equipo, debido al movimiento aleatorio de los electrones. Este ruido es llamado ruido térmico.

La potencia del ruido térmico que afecta un rango dado de frecuencias es proporcional a la temperatura absoluta y al ancho de banda de frecuencias en cuestión, es decir:

$$P_r = KTB$$

donde

P_r = Potencia del ruido en watts

k = Constante de Boltzman 1.3×10^{-23} watts seg/°k

T = Temperatura en °k

B = Ancho de banda en Hertz.

La temperatura de ruido de una fuente de ruido es la temperatura que produce la misma potencia de ruido sobre el mismo rango de frecuencias.

Así, si una fuente de ruido crea ruido de potencia P_r , su temperatura de ruido, algunas veces llamada temperatura de ruido equivalente, ENT, es

$$T = \frac{P_r}{kB}$$

Densidad de Ruido. 77

El término densidad de ruido se refiere al ruido por Hertz de ancho de banda:

$$\text{densidad de ruido} = \frac{P_r}{B} = KT$$

Relación Portadora a Ruido.

Una relación frecuentemente usada para establecer la calidad de un satélite es:

$$\frac{\text{Potencia de la portadora recibida}}{\text{densidad de ruido}} = \frac{P_R}{KT}$$

La potencia de la portadora se simboliza frecuentemente con C. La anterior relación $\frac{C}{N}$ es llamada la relación señal a ruido. En la Fig. 39 se grafica la relación $\frac{C}{N}$ contra el EIRP para un enlace de subida de un típico satélite doméstico Norte-Americano. Se puede ver que dicha relación no puede ser mejorada hasta algún cierto nivel debido a que se alcanza una saturación en el canal.

Fuentes externas de ruido.

Las siguientes son fuentes externas de ruido: El sol, la luna, la tierra, ruido galáctico, ruido cósmico, ruido del cielo, ruido atmosférico y ruido hecho por el hombre. Estas fuentes difieren en su intensidad, frecuencias y localización en el espacio.

Si la antena de un satélite apunta hacia el sol, la señal será prácticamente contaminada debido a la temperatura de ruido del sol que es de 100,000°k ó más.

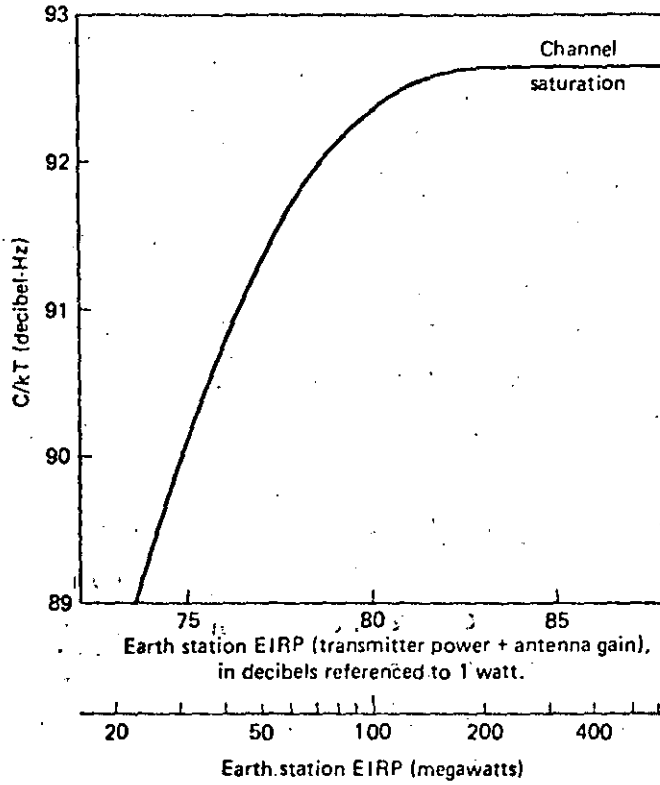


Figure 7.1 C/kT for a typical American domestic satellite.

Fig. 39

El ruido del sol varía con la actividad solar.

La temperatura del ruido del cielo es de aproximadamente 30°K . La directividad de una antena no sólo es para enfocar el haz sino también para proteger la señal recibida, de otras fuentes de ruido.

La temperatura de ruido de la tierra, vista desde el espacio, es en promedio de 254°K . Una antena de satélite con un ancho de haz igual al ancho proyectado de la tierra recibiría esta cantidad de ruido, como fondo a las señales que vienen desde la tierra. Debido a las variaciones del terreno, haces dirigidos a alguna porción de la tierra reciben una temperatura de ruido ligeramente mayor a 254°K .

El ruido galáctico se refiere al ruido de las estrellas en la galaxia. Este ruido decrece rápidamente a altas frecuencias y tiene efectos despreciables arriba de 1 GHz.

El ruido cósmico se refiere a otro ruido del espacio exterior y también es despreciable a frecuencias arriba de 1 GHz.

Los destellos de luz y las descargas electrostáticas en la atmósfera son una fuente mayor de ruido abajo de 30 MHz. Afortunadamente son despreciables a las frecuencias utilizadas en los satélites.

El ruido atmosférico se origina principalmente de las moléculas de oxígeno y vapor de agua, las cuales absorben la radiación. Consecuentemente las frecuencias en las cuales la absorción atmosférica es alta son las mismas en las que el ruido atmosférico es alto. La Fig. 40 muestra las temperaturas de ruido de vapor de agua y oxígeno atmosférico. El ruido hecho por el hombre, el cual es una plaga a frecuencias bajas, tiene un efecto pequeño arriba de 1 GHz. Surge principalmente de la maquinaria eléctrica y es mucho mayor en áreas industriales. Si estuviera pre-

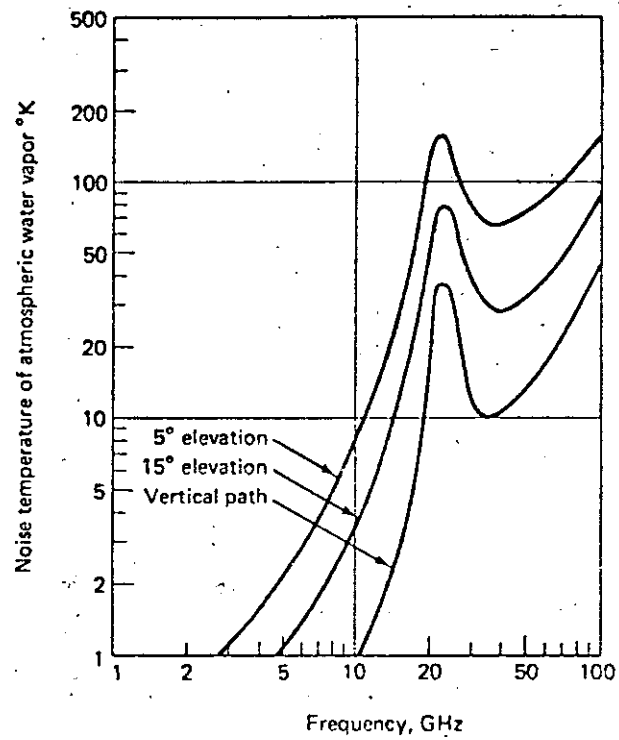
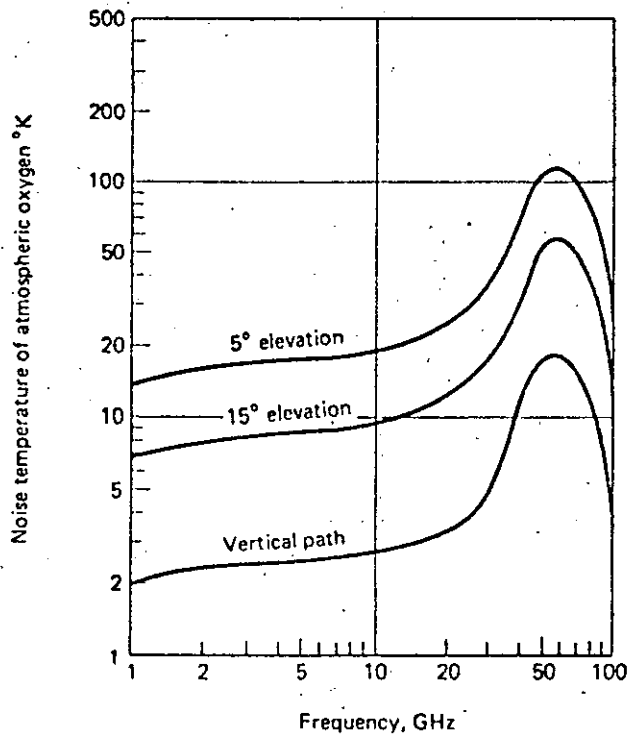


Fig. 40

sente podría reducirse al cubrirse la antena. Está virtualmente ausente en el espacio.

La Fig. 41 muestra cómo afecta a la señal la combinación de estos diferentes tipos de ruido. El ruido recibido en el satélite, que domina, es la temperatura de ruido de la Tierra. En la estación terrena hay una ventana de ruido entre el efecto del ruido cósmico y el efecto del vapor de agua.

Mal tiempo.

La lluvia muy intensa causa más ruido en la estación terrena que todas las otras fuentes de ruido combinadas. Como en el caso de la absorción, este efecto es peor a frecuencias mayores. La Fig. 42 muestra el efecto de la lluvia, nubes y niebla intensas. Es recomendable evitar tanto como sea posible ángulos de elevación bajos a estas frecuencias.

Figura de Mérito.

Debido a que la señal recibida es muy débil, tanto en el satélite como en la estación terrena, es importante que la antena receptora y la parte electrónica introduzcan tan poco ruido como sea posible. Para evitar pérdidas y ruido en las líneas que conectan la antena receptora a la electrónica, la antena tiene usualmente el preamplificador construido internamente como se muestra en la Fig. 43. La eficiencia de tal combinación usualmente se cuantifica como la relación de la ganancia a la temperatura de ruido y se llama la figura de mérito

$$\text{Figura de Mérito} = \frac{G}{T}$$

donde G = antena y ganancia del preamplificador.

T = temperatura de ruido en el sistema receptor.

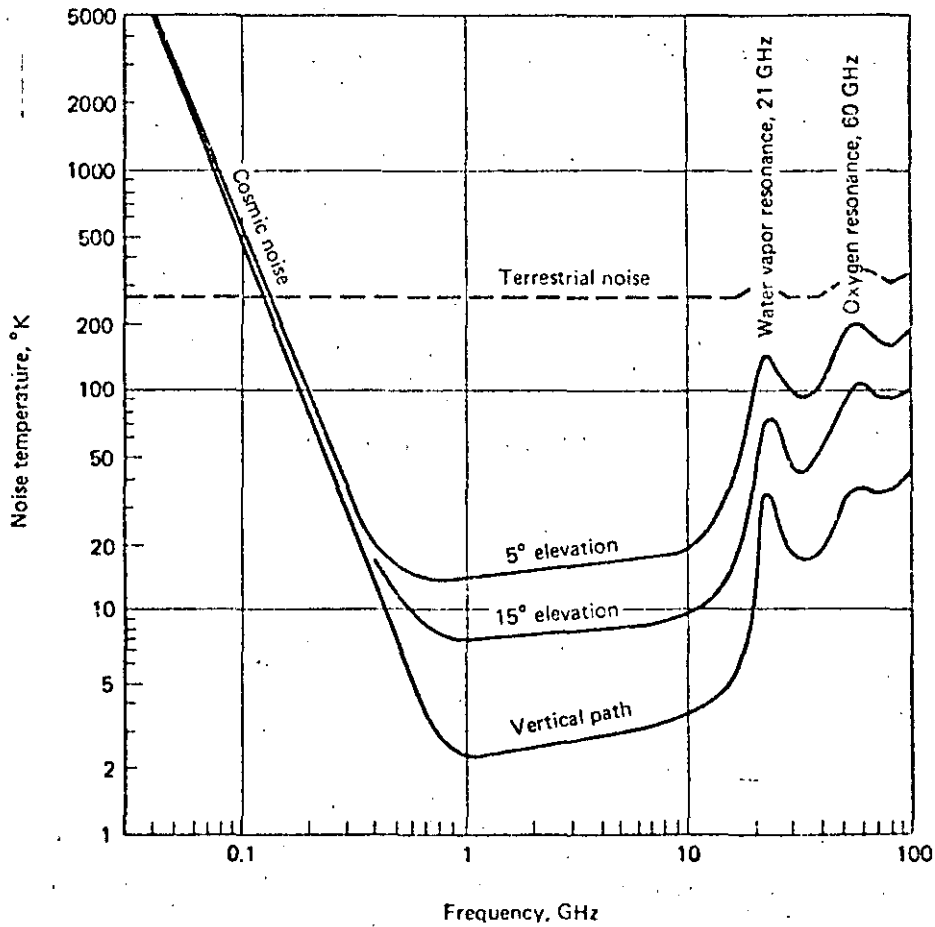


Fig. 41

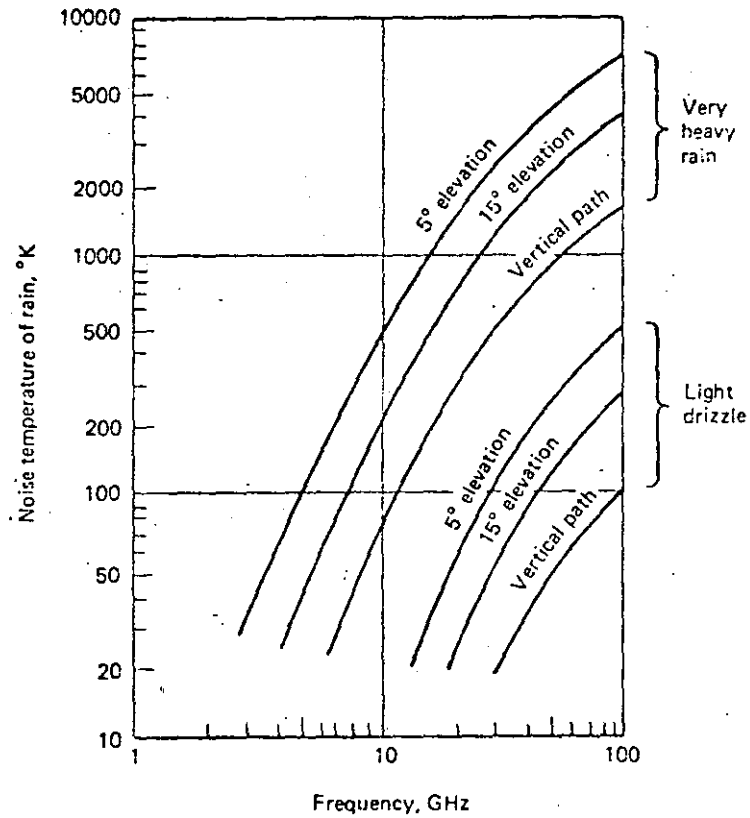
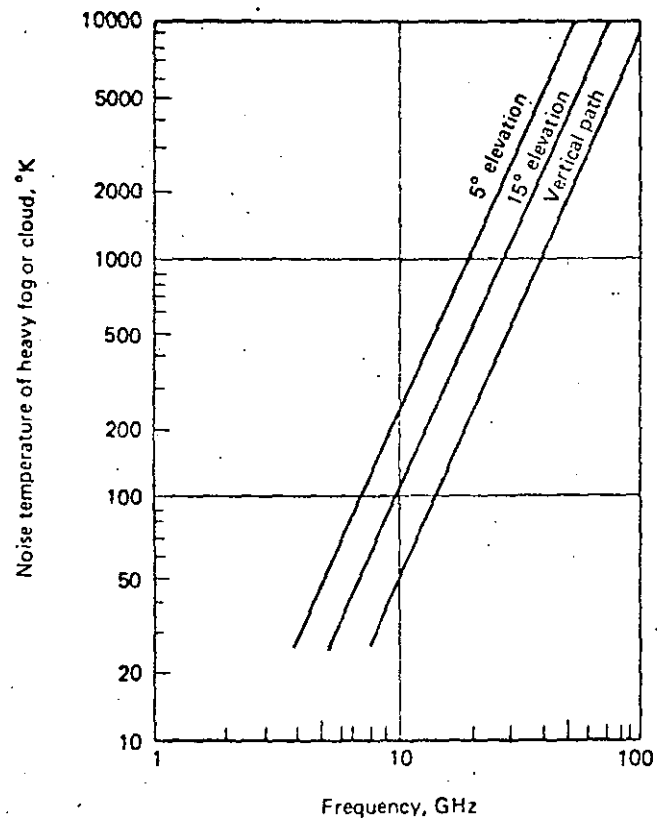


Fig. 42

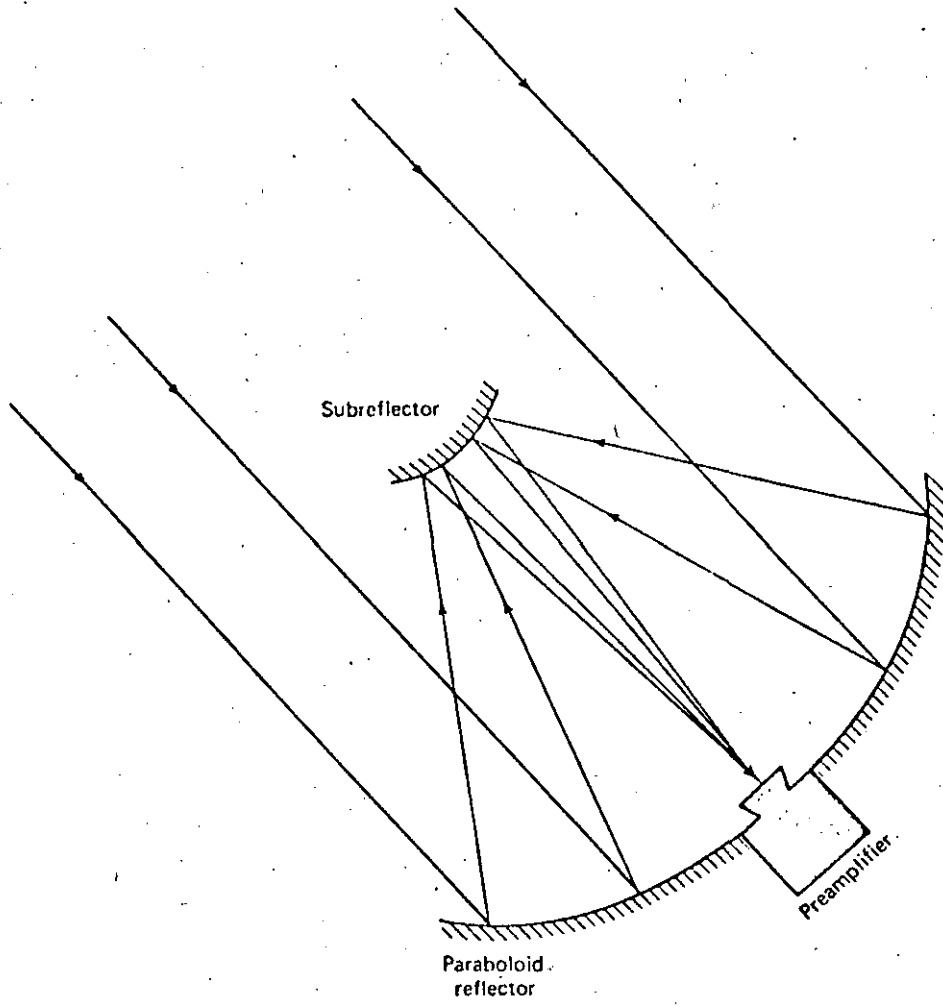


Fig. 43

Esta figura de mérito se relaciona a la relación señal a ruido resultante y por consiguiente indica la capacidad relativa del subsistema receptor para recibir una señal. La Fig.44 grafica algunos valores típicos para receptores con electrónica sin enfriamiento.

Ruido del equipo.

La temperatura de ruido T del equipo receptor es originado tanto por la estructura de la antena como por la electrónica asociada. Las primeras estaciones terrenas usaron preamplificadores enfriados criogénicamente para reducir la temperatura de ruido. Actualmente, con satélites más potentes, se puede usar equipo receptor más barato con una figura de merito menor, teniendo tanto una antena más pequeña como una temperatura de ruido mayor. Así que con una potencia de satélite mayor se puede tener equipo receptor más barato. La Tabla I muestra algunas figuras de temperatura de ruido típicas para diferentes tipos de electrónica. La relación señal a ruido resultante se calcula asumiendo que la temperatura de ruido de antena es 60°K y entra al amplificador una señal de 10 picowatts.

Una relación señal a ruido de 10 dB es típica en enlaces de satélites, mientras que una relación señal a ruido de 30 dB es adecuada para enlaces terrestres. Se pueden insertar estos valores en la ecuación de Shannon y comparar los valores teóricos entre un satélite típico y un enlace terrestre del mismo ancho de banda.

Las componentes de ruido incluidas en T pueden dividirse en 4 categorías:

- . RUIDO DE ANTENA
- . RUIDO DE COMPONENTE PASIVA
- . RUIDO DE ESCAPE (HPA)
- . ETAPAS DE AMPLIFICACION

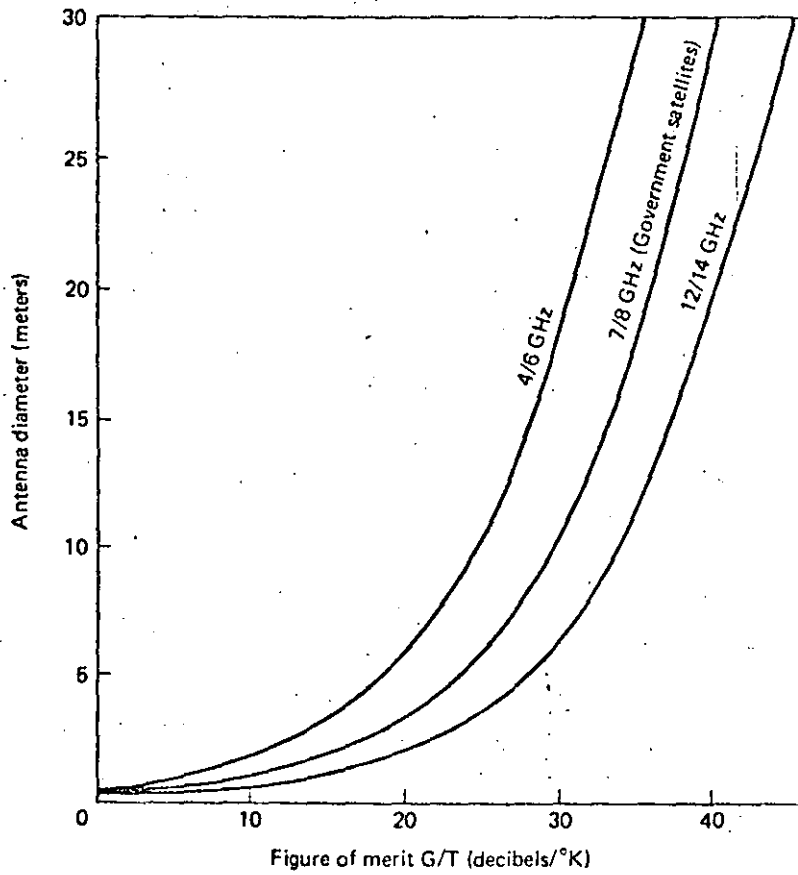


Fig. 44

Tabla 7.1 Noise figures for typical types of receiver equipment and typical resulting signal-to-noise ratios.

Type of Electronics	Noise Temperature of Electronics	Typical Noise Temperature of Antenna	Combined Noise Temperature of Antenna & Electronics	S/N for a Received Signal of 10 picowatts (10^{-11} watts)
Maser (cooled to 4.2°K)	10	60	70	14.6 decibels
Parametric amplifier (cooled to 25°K)	35	60	95	13.3 decibels
Uncooled parametric amplifier	120	60	180	10.5 decibels
Inexpensive parametric amplifier	300	60	360	7.5 decibels
Tunnel diode amplifier	530	60	590	5.3 decibels
Schottky mixer	1000	60	1060	2.7 decibels

A 4/6-GHz Link.
Satellite Antenna: Earth-Coverage.
Earth Antenna: 12 meters.
Moderately Low-Cost Electronics in Earth Station.

A 12/14-GHz Link.
Satellite Antenna: 1.8 Meters.
Earth Antenna: 1.8 Meters.
Low-Cost Earth-Station Receiver.

A 20/30-GHz Link for Common Carrier Use.
Satellite Antenna: 2 Meters.
Earth Antenna: 27.5 Meters.
Cryogenically Cooled Receiver.

A 12/14-GHz Link on a Broadcast Satellite.
Satellite Antenna: 9 Meters.
Earth Antenna: 1.8 Meter Receiver-only; 12-Meter Transmit.
Low-Cost Earth Station.

Up-Link

Transmitter power, dBw*	35	25	20	20
Transmitter system loss, decibels	-1	-1	-1	-1
Transmitting antenna gain, decibels	55	46	76	62
Atmospheric loss, decibels	0	-0.5	-2	-0.5
Free space loss, decibels	-200	-208	-214	-208
Receiving antenna gain, decibels	20	46	53	60
Receiver system loss, decibels	-1	-1	-1	-1
Received power, dBw*	-92	-93.5	-69	-68.5
Noise temperature, °K	1000	1000	1000	1000
Received bandwidth, MHz	36	36	350	36
Noise, dBw*	-128	-128	-118	-128
Received SNR, decibels	36	34.5	49	59.5
Loss in bad storm, decibels	2	10	25	10
Received SNR in bad storm, decibels	34	24.5	24	49.5

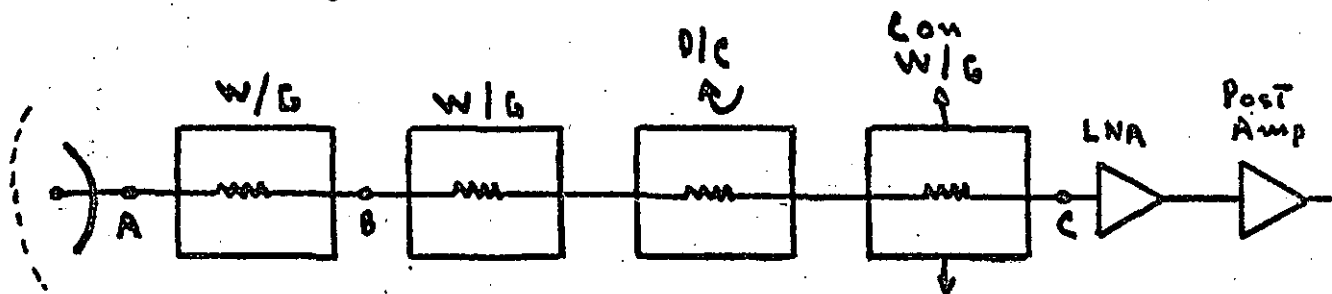
Down-link

Transmitter power, dBw*	18	20	8	10
Transmitter system loss, decibels	-1	-1	-1	-1
Transmitting antenna gain, decibels	16	44	49	58
Free space loss, decibels	-197	-206	-210	-206
Atmospheric loss, decibels	0	-0.6	-2	-0.6
Receiver antenna gain, decibels	51	44	72	44
Receiver system loss, decibels	-1	-1	-1	-1
Received power, dBw*	-114	-100.6	-85	-96.6
Noise temperature, °K	250	1000	250	1000
Received bandwidth, MHz	36	36	350	36
Noise, dBw*	-131	-128	-121	-128
Received SNR, decibels	17	27.4	36	31.4
Loss in bad storm, decibels	2	10	25	10
Received SNR in bad storm, decibels	15	17.4	11	21.4

*dBw means decibels referenced to one watt. I. E. 1 watt = 0 dBw; 100 watts = 2 dBw, etc.

La Fig. 45 representa las contribuciones de ruido gráficamente. La Fig. 46 muestra aproximadamente la variación de ruido del cielo con el ángulo de elevación. A un ángulo de 5° vemos que la temperatura de ruido del cielo alcanza el orden de 25°K. Será visto también que el ruido de antena mínimo ocurre cuando la antena está en el Zenith (es decir, un ángulo de elevación de 90°). Los ángulos de elevación son con respecto al horizonte; así, el ángulo de elevación sería de 0° cuando la antena apunta directamente al horizonte. El derramamiento de antena se refiere a la energía radiada de la antena al suelo y dispersada por los elementos metálicos que sostienen los dispositivos de alimentación. La suma total del ruido de antena puede alcanzar 39 ó 40 K, 25 de los cuales es ruido del cielo.

Para calcular toda la temperatura del ruido del sistema T_{sys} de los diversos elementos en Tandem se hace uso de la cadena receptora como sigue:



donde A, B y C son puntos de referencia o planos de referencia. A es la base del punto radiador, B es la base del pedestal de la antena y C es el punto de entrada al amplificador de bajo ruido (LNA).

Para calcular la temperatura de ruido del sistema T_{sys} , se puede decir que:

$$T_{sys} = T_{ant} + T_r$$

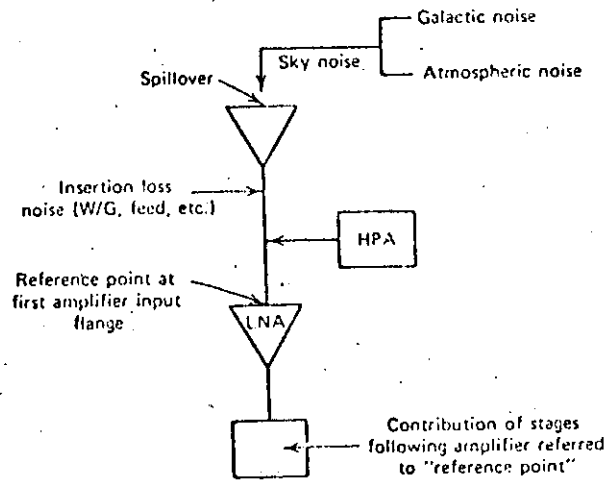
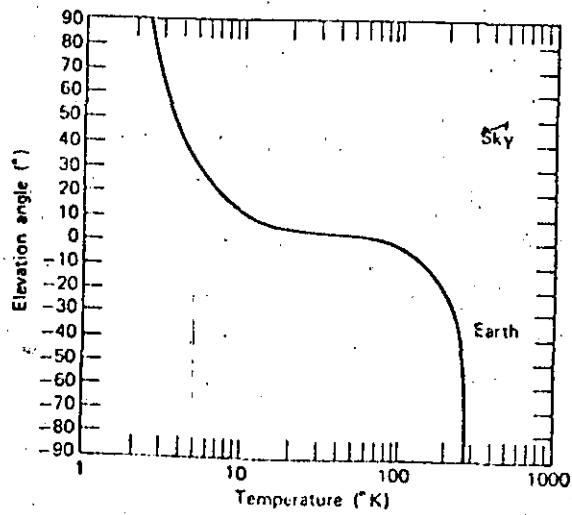


Figure 7.5 Graphical representation of noise contributors. HPA = high-power amplifier; LNA = low-noise amplifier.

Fig. 45



Approximate sky noise variation with antenna elevation angle (4 GHz).

Fig. 46

donde: T_{ant} = Temperatura de ruido de la antena

T_r = Temperatura de ruido del sistema receptor.

El primer paso es establecer un punto de referencia. Este es un punto arbitrario desde donde se calcula la ganancia de la antena también como su temperatura de ruido T_{ant} . La T_{sis} variará conforme G varíe, dependiendo del punto de referencia. Encontraremos que conforme el punto de referencia se mueva del alimentador de la antena, la ganancia disminuirá y así también la temperatura de ruido. Sin embargo, la G/T para un sistema dado se mantendrá constante, sin importar la referencia. En la anterior figura, cada componente de pérdidas óhmicas es un generador de ruido, como lo es cada componente activa como el LNA y el post-amplificador, el mixer, los amplificadores de FI y así sucesivamente. Las contribuciones de ruido a la izquierda del plano de referencia están incluidas en la temperatura de antena (T_{ant}) en la ecuación anterior y siempre incluye el ruido del cielo. A la derecha del plano de referencia, esto es, hacia el sistema, todas las contribuciones de ruido se incluyen en T_r .

Para diferenciar entre pérdidas óhmicas y no óhmicas, considere que todos los dispositivos con una pérdida de inserción están en la categoría óhmica y todas las pérdidas no asociadas con una pérdida de inserción son no óhmicas. Un ejemplo de pérdidas no óhmicas es el espacio libre.

El análisis para determinar T_{sis} es una operación de dos pasos, es decir T_{ant} y T_r se calculan separadamente y entonces se realiza la suma.

Cuando se calcula la contribución de ruido de una pérdida -- óhmica, la cual está dada en las unidades tradicionales de medición, el decibel, debemos convertir el valor del decibel a su relación numérica equivalente:

$$\text{Pérdidas (dB)} = 10 \log_{10} \left(\frac{P_1}{P_2} \right)$$

sea $\frac{P_1}{P_2} = L$. Entonces:

$$\text{Pérdidas(Relación)} = \log_{10}^{-1} \left(\frac{L}{10} \right)$$

Supongamos que el punto de referencia fuera el punto B, hubiera una pérdida de cubierta de 1 dB y las pérdidas de la guía de onda a la base del pedestal fueran 1.3 dB. Calcular la relación de pérdidas,

$$\begin{aligned} \text{Pérdidas(relación)} &= \log_{10}^{-1} \left(\frac{2.3}{10} \right) \\ &= 1.698 \end{aligned}$$

Asumiendo que L_T sean las pérdidas totales de la red de la antena, incluyendo la cubierta (radome), expresada como una relación de pérdidas. Entonces:

$$T_{ant} = \frac{(L_T - 1) (T_{amb} + T_s)}{L_T}$$

donde T_s = ruido del cielo y T_{amb} = temperatura ambiente, tradicionalmente dada como 290 K (17°C).

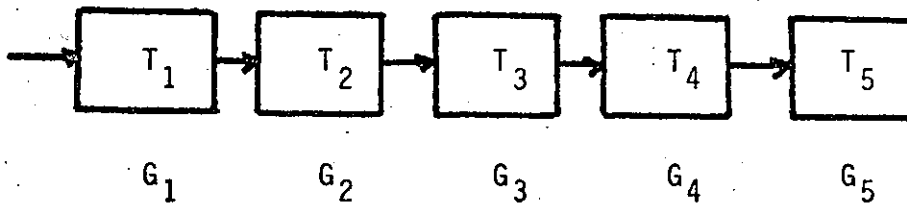
La temperatura de ruido del receptor T_r es el ruido total recibido obtenido al referirnos a los efectos de la contribución del LNA (y subsecuentes amplificadores o mezcladores) y las pérdidas del circuito de entrada al mismo plano de referencia como en el caso de la temperatura de ruido de antena.

En otras palabras, estamos tratando con todas las contribuciones de ruido a la derecha del plano arbitrario de referencia.

Cuando se calcula T_r se debe utilizar la fórmula de cascada tradicional para temperatura de ruido:

$$T_r = T_1 + \frac{T_2}{G_1} + \frac{T_3}{G_1 G_2} + \frac{T_4}{G_1 G_2 G_3} + \frac{T_5}{G_1 G_2 G_3 G_4} + \dots$$

donde T_1 = Temperatura de ruido del contribuidor de ruido n y G_n = ganancia del contribuidor n , $n = 1, 2, \dots$



Recuerde que las pérdidas de un dispositivo que atenúa una señal pueden ser expresadas como una ganancia equivalente, la cual es menor que 1.

La temperatura de ruido en el receptor T_r se expresa como:

$$T_r = (L_i - 1) T_{amb} + T_{LNA} L_i + \frac{T_{pa} L_i}{G_{LNA}} + \dots$$

donde L_i = suma de las pérdidas desde el plano de referencia a la entrada del LNA, donde estas pérdidas se expresan como una relación, T_{LNA} = Temperatura de ruido en grados Kelvin del LNA, G_{LNA} = ganancia del LNA, y T_{pa} = temperatura de ruido en grados Kelvin del postamplificador, donde sea necesario, o bien del mezclador.

Ejemplo.

Dado un ruido del cielo de $50^\circ K$, pérdidas en gafa de onda de $0.2dB$ a la base del pedestal de antena, y otras pérdi-

das de inserción de conmutación de guía de onda de 0.07 dB,
 $T_{LNA} = 105k$, $G_{LNA} = 30dB$ y $T_{pa} = 600 k$.

1. ¿Cuál es el valor de T_{sis} cuando el plano de referencia es la base del pedestal de la antena?.
2. Si la ganancia de la antena es de 40dB, ¿cuál es la relación G/T usando el mismo plano de referencia como en el punto 1?.

T_{ant}

Suma de las pérdidas óhmicas al plano de referencia

$$L_T = \log_{10}^{-1} \left(\frac{0.2}{10} \right)$$

$$= 1.047$$

considérese $T_{amb} = 290 K$, entonces

$$T_{amb} = \frac{(L_T - 1) T_{amb} + T_s}{L_T}$$

$$= \frac{(1.047 - 1)290 + 50}{1.047} = \frac{13.63 + 50}{1.047} = 60.77K$$

T_r

Suma de las pérdidas desde el plano de referencia a la entrada del LNA:

Pérdidas en guía de onda	0.015dB
Pérdidas en acoplador direccional	0.09
Conmutación de guía de onda	<u>0.07</u>
Total	0.175dB

entonces

$$L_i = \log_{10}^{-1} \left(\frac{0.175}{10} \right)$$

$$= 1.041$$

$$T_r = (L_i - 1) (T_{amb} + T_{LNA} L_i) + \frac{T_{pa} L_i}{G_{LNA}}$$

$$= (0.041) 290 + 105 (1.041) + \frac{600(1.041)}{1000}$$

$$= 121.8 \text{ K}$$

Así que:

$$T_{sis} = T_{ant} + T_r = 60.77 + 121.8$$

$$T_{sis} = 182.57$$

por otro lado

$$G = 40 \text{ dB} - 0.2 \text{ dB} = 39.8 \text{ dB}$$

Entonces

$$\frac{G}{T} = G - 10 \log_{10} T_{sis}$$

$$= 17.18 \text{ dB}$$

Obsérvese que G_{LNA} debe convertirse de su valor en decibeles a su valor numérico equivalente; con este caso 30 dB es equivalente a 1000. También, para calcular la relación $\frac{G}{T}$, a la ganancia de la antena deben reducirse las pérdidas del elemento radiador de la antena al plano de referencia seleccionado.

MODULACION EN SATELITES.

La técnica de modulación que domina en los sistemas de comunicaciones vía satélite es la modulación en frecuencia (FM). El sistema FM es ampliamente usado en radiodifusión y en microondas terrestres, de tal forma que la teoría era muy bien entendida cuando los satélites de comunicaciones tenían el gran auge y desarrollo, y también se disponía de la tecnología cuando comenzaron a operar. Además, esta técnica provee la suficiente relación señal a ruido, por ejemplo 30 dB en el sistema INTELSAT IV. La alternativa de utilizar modulación digital, PSK por ejemplo, se ha considerado seriamente, sin embargo se sigue manteniendo el uso de FM como en el caso de microondas terrestres. La utilización de modulación digital en satélites se hará con la misma rapidez que se use modulación digital en microondas terrestres, ya que finalmente, éstas son las que alimentan a las estaciones terrenas. Sin embargo, si la información está en forma digital, se puede utilizar modulación digital directamente.

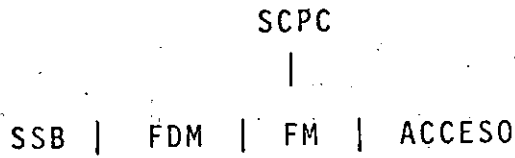
MODULACION ANALOGICA.

En un sistema troncal tal como INTELSAT o COMSTAR las señales telefónicas están en grupos o supergrupos que consisten de 12 ó 60 canales los cuales han sido multicanalizados por división de frecuencia (FDM) Fig. 47.

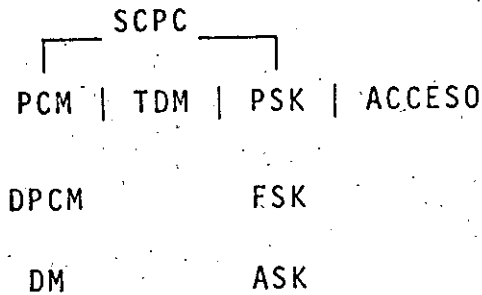
Como se puede observar el sistema FM es similar al usado en microondas terrestres, excepto que se requiere ampliar más la desviación de frecuencia para mejorar la relación señal a ruido ($\frac{S}{N}$). Una sola portadora puede ser modulada por hasta 900 canales de banda base y ocupar un ancho de banda de 36 MHz Fig. 48 (no todos los transpondedores tienen ancho de banda de 36 MHz).

MODULACION

ANALOGICA

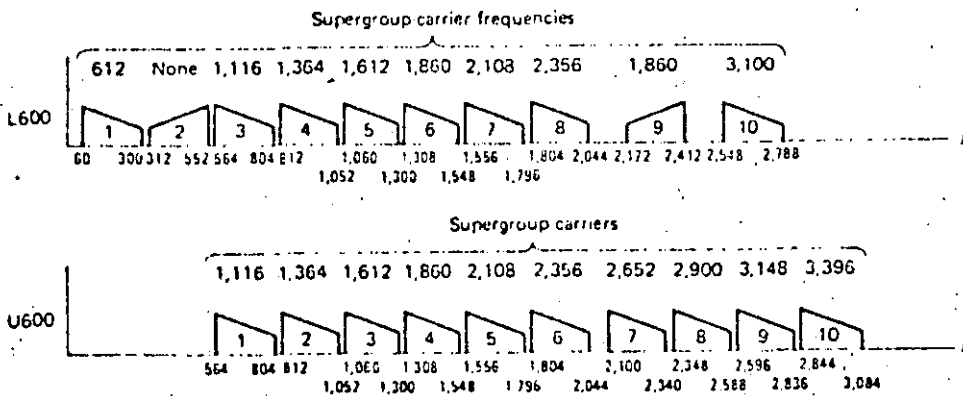
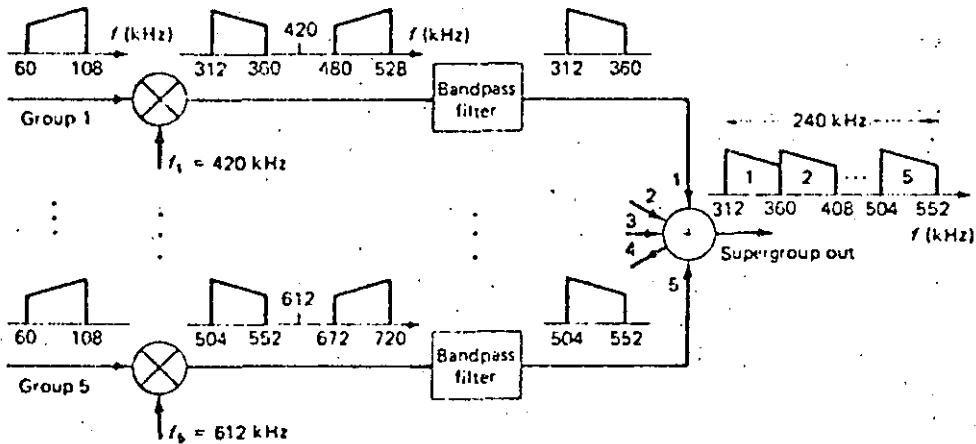
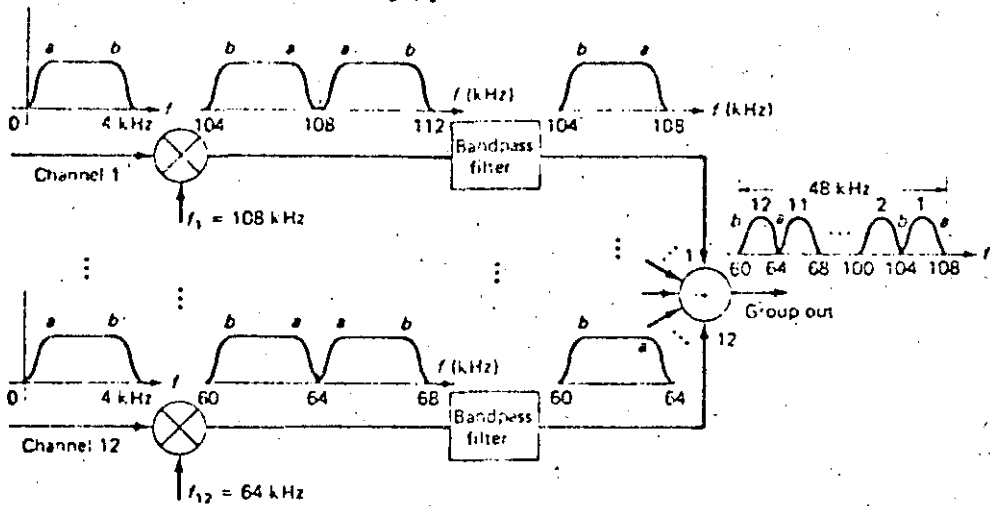


DIGITAL



SISTEMA	ANCHO DE BANDA	RESPUESTA A CC.	$\frac{1}{\alpha} \left(\frac{S}{N} \right)_d$	EFICIENCIA	COMPLEJIDAD	APLICACION TIPICA
AM	$B_T = 2fx$	NO	1/3	<50%	MINIMA	RADIODIFUSION COMERCIAL
DBL	$B_T = 2fx$	SI	1	100%	MEDIA	SISTEMAS BAJA FRECUENCIA
BLU	$B_T = fx$	NO	1	100%	MAXIMA	TRANSMISION DE VOZ
BLR	$fx < B_T < 2fx$	SI	1	100%	MAXIMA	SISTEMAS DE GRAN ANCHO DE BANDA
BLR+P	igual a VSB	NO	1/3	<50%	MEDIA	VIDEO DE TV
FM	$B_T = 2f\Delta + 2fx$	SI	$\frac{3}{2} \left(\frac{f\Delta}{fx} \right)^2$	--	MEDIA	RADIODIFUSION COMERCIAL
PM	$B_T = 2f\Delta + 2fx$	SI (con ajuste)	$k_p^2 / 2$	--	MEDIA	TRANSMISION DE DATOS Y GENERACION DE FM

COMPARACION DE LOS SISTEMAS DE MODULACION ANALOGICOS



Note: All frequencies in kHz.

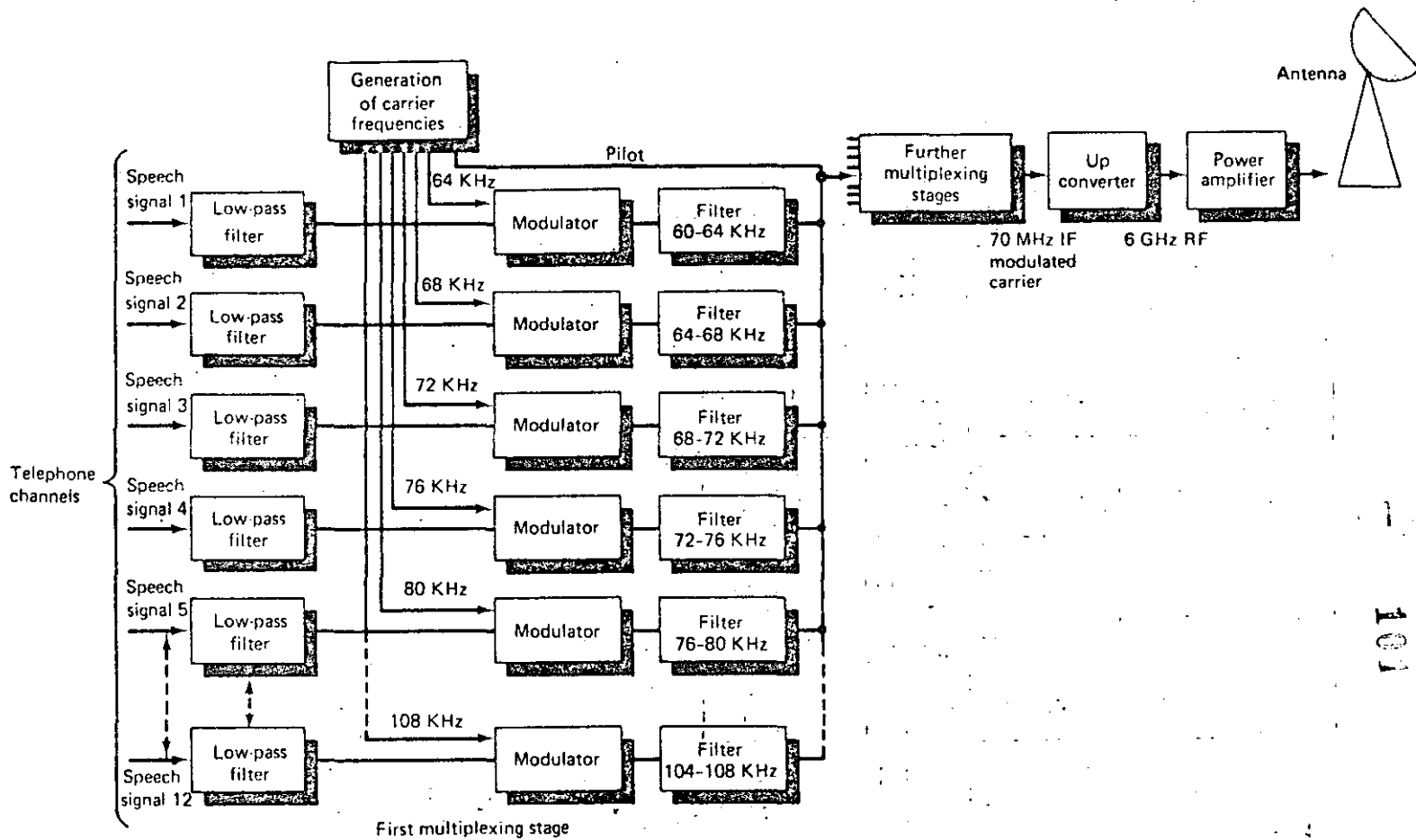


Fig. 47

$$F_S(\omega) = \frac{1}{2\pi} F(\omega) * P_T(\omega)$$

$$T = \frac{1}{2 f_m} = \frac{\pi}{\omega_m}$$

$$\omega_0 = \frac{2\pi}{T} = 2 \omega_m$$

$$P_T(\omega) = 2 A_T \omega_m \sum_{n=-\infty}^{\infty} \text{Sinc}(n\pi \omega_m) \delta(\omega - 2n\omega_m)$$

$$F_S(\omega) = \frac{A_T \omega_m}{\pi} F(\omega) * \sum_{n=-\infty}^{\infty} \text{Sinc}(n\pi \omega_m) \delta(\omega - 2n\omega_m)$$

$$= \frac{A_T}{T} \sum_{n=-\infty}^{\infty} \text{Sinc}(n\pi \omega_m) F(\omega) * \delta(\omega - 2n\omega_m)$$

$$= \frac{A_T}{T} \sum_{n=-\infty}^{\infty} \text{Sinc}(n\pi \omega_m) F(\omega - 2n\omega_m)$$

Obsérvese que $F(w)$ se repite sin traslaparse
siempre que

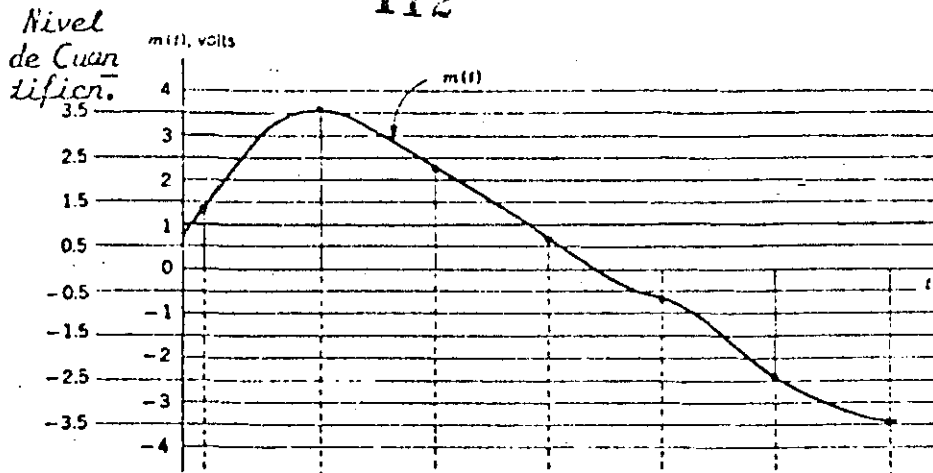
$$W_0 \geq 2 W_m$$

$$\frac{2\pi}{T} \geq 2(2\pi f_m)$$

$$T \leq \frac{1}{2f_m}$$

$$\underline{\underline{f_s \geq 2 f_m}}$$

Muestras/s



Valor Simple	1.3	3.6	2.3	0.7	-0.7	-2.4	-3.4
Nivel más cercano	1.5	3.5	2.5	0.5	-0.5	-2.5	-3.5
No. de Código	5	7	6	4	3	1	0
Representación Bin.	101	111	110	100	011	001	000

Se muestrea regularmente una señal. En la figura se han indicado los niveles de cuantificación así como su representación binaria. Para cada muestra se da el valor de cuantificación.

FIGURA N° 1-A

Binario				Decimal
k_3	k_2	k_1	k_0	
0	0	0	0	0
0	0	0	1	1
0	0	1	0	2
0	0	1	1	3
0	1	0	0	4
0	1	0	1	5
0	1	1	0	6
0	1	1	1	7
1	0	0	0	8
1	0	0	1	9
1	0	1	0	10
1	0	1	1	11
1	1	0	0	12
1	1	0	1	13
1	1	1	0	14
1	1	1	1	15

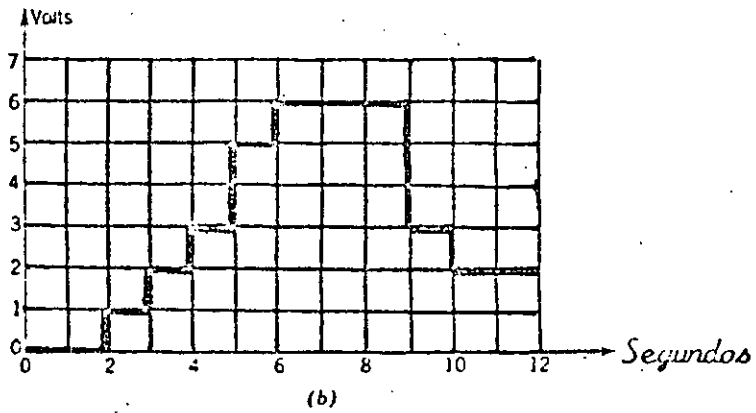
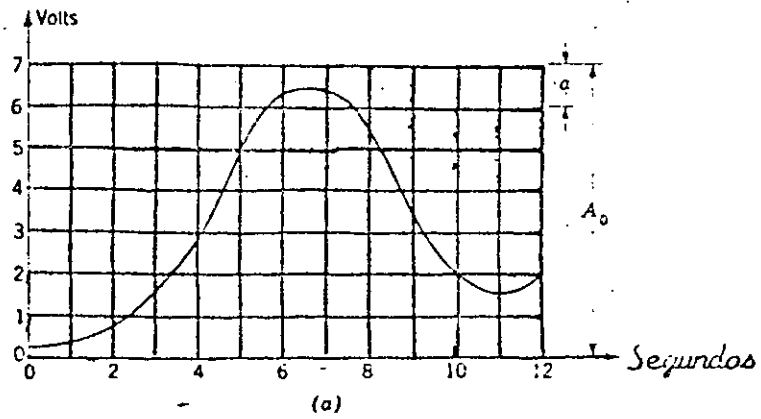


FIGURA N° 1
MUESTREO Y CUANTIFICACION: a) Señal
muestreada y cuantificada. b) versión

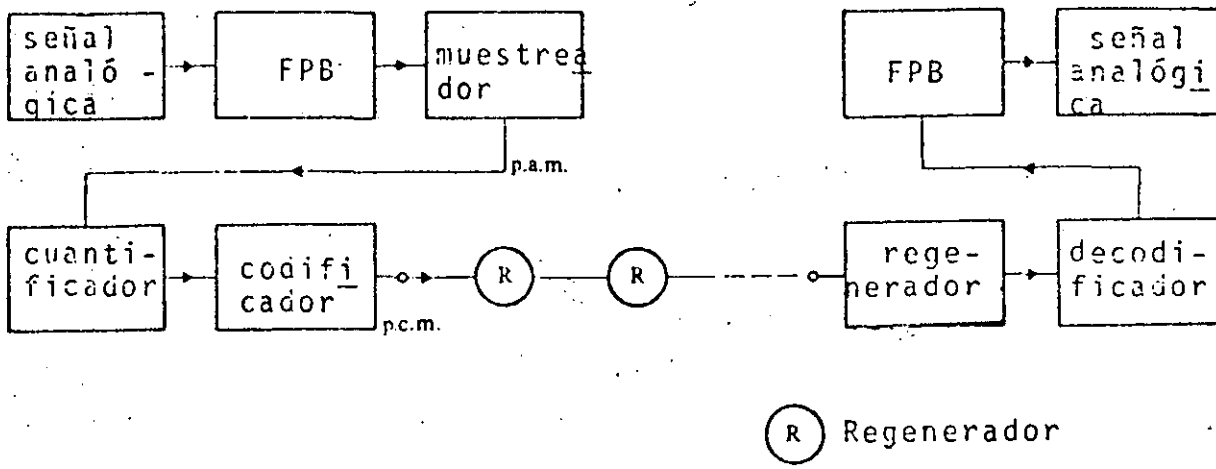


FIGURA N° 2
DIAGRAMA EN BLOQUES DEL SISTEMA PCM

TABLA III
PARAMETROS DE PCM

Tipo de señal	Ancho de Banda	Tasa de muestreo	No. de intervalos de cuantific.	Long. de la palabra en el código
voz	de 300 Hz a 3400 Hz	8 KHz	128 ó 256	7 ó 8
programa de música	15 KHz	32 KHz	2048	11
TV a color	5.5 MHz	13 MHz	512	9

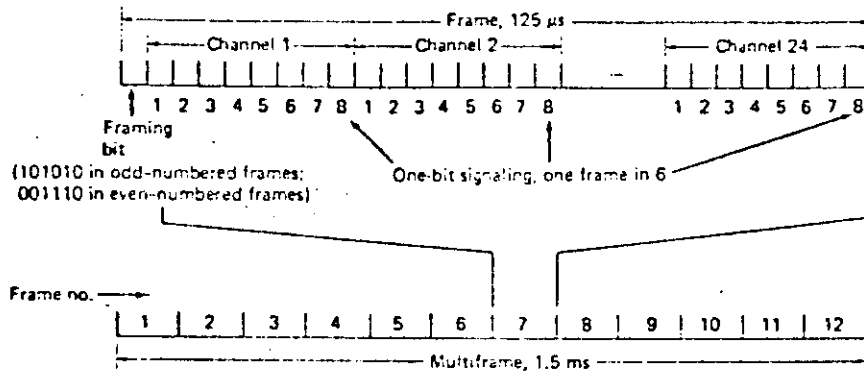


FIGURA N° 12.

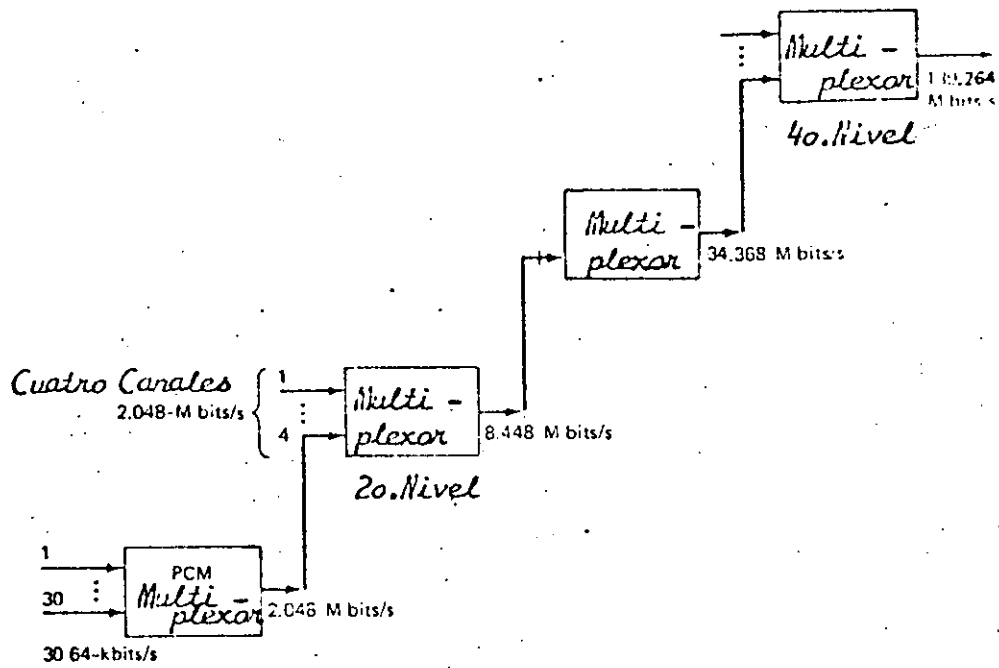


FIGURA N° 13
 JERARQUIA DIGITAL: Recomendación CCITT.

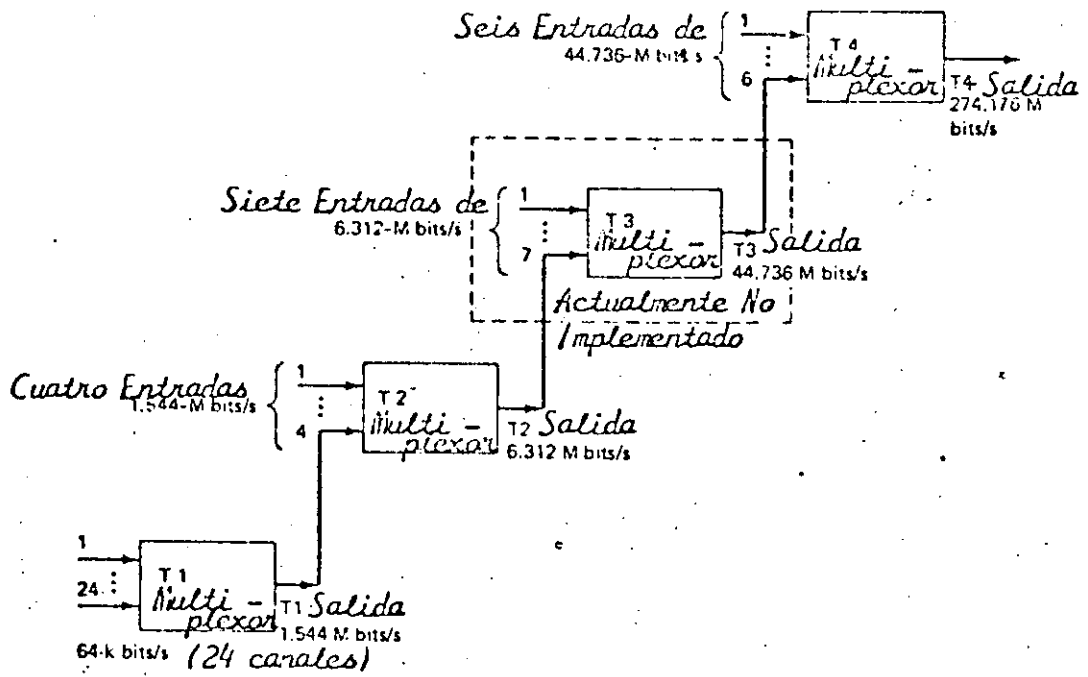


FIGURA N° 14
 SISTEMA ATT : Jerarquia Digital.

TABLA IV
Velocidades Estándar de Transmisión en Estados Unidos, Canadá, Japón
Europa.

Jerarquía. Nivel No.	EU/Canadá (nb/s)	Japón (nb/s)	Europa (nb/s)
1	1.544	1.544	2.048
2	6.312	6.312	8.448
3	44.736	32.064	34.368
4	274.176	97.728	139.264
5	-	396.200	560-840

TABLA V
Capacidad Estándar de Canales de Voz en Sistemas PCM.
Estados Unidos, Canadá, Japón y Europa.

Jerarquía. Nivel No.	c a p a c i d a d		
	EU/Canadá	Japón	Europa
1	24	24	30
2	96	96	120
3	672	480	480
4	4032	1440	1920
5	-	5760	7680-11520

Ancho de banda (MHz)

No. de Canales	FDM	PCM coseno elevado	PCM 1/2 coseno elevado
24	0.92	3.08	2.28
60	4.23	7.68	5.75
120	5.88	15.36	11.5
600	14.45	76.8	57.5

113

111.

TABLA II

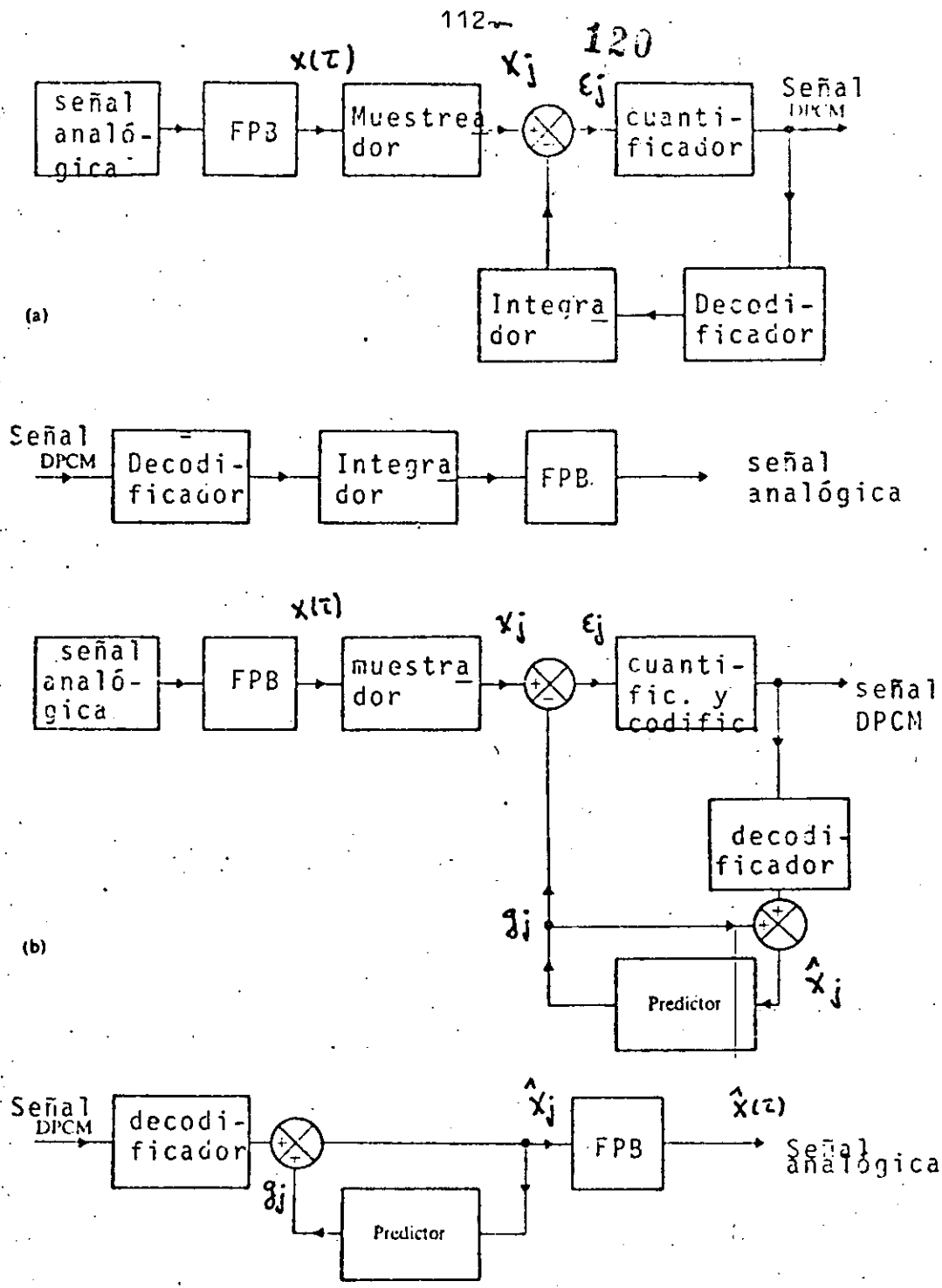


FIGURA N° 15
 DIAGRAMA EN BLOQUES DEL SISTEMA PCM DIFERENCIAL: a) Transmisor y receptor de un sistema PCM simple; b) Transmisor y receptor de un sistema PCM con predictor.

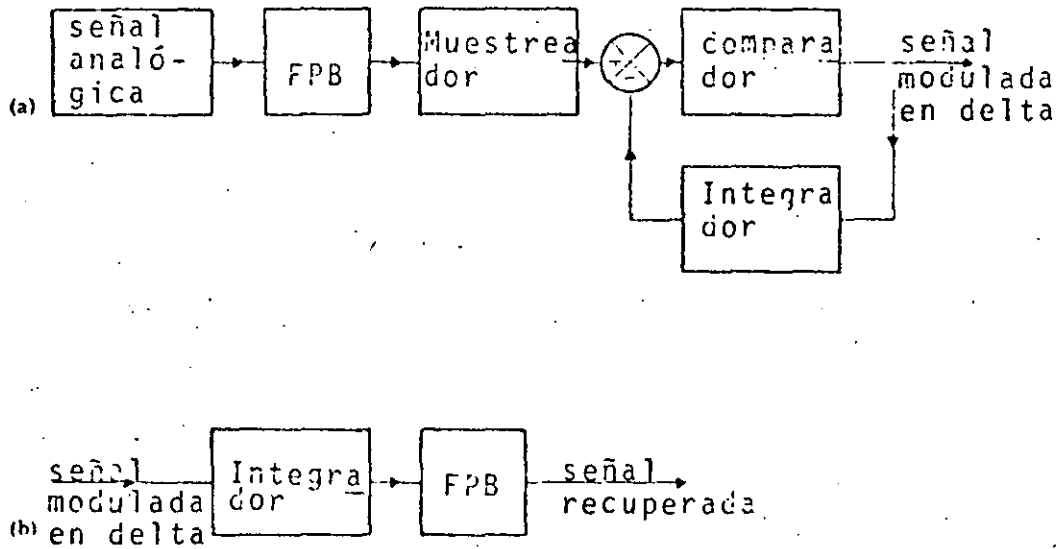


FIGURA N° 16
DIAGRAMA EN BLOQUES DE UN SISTEMA DE MODULACION DELTA.
SIMPLE a) Transmisor; b) Receptor.

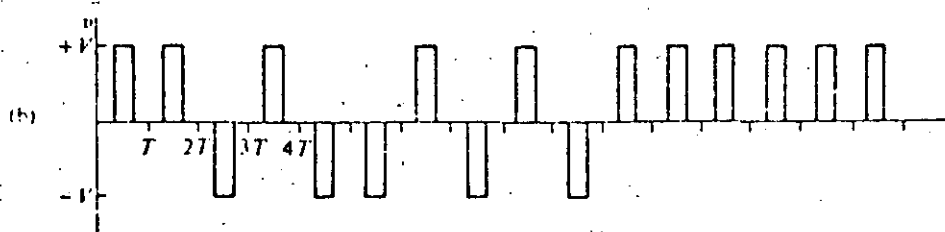
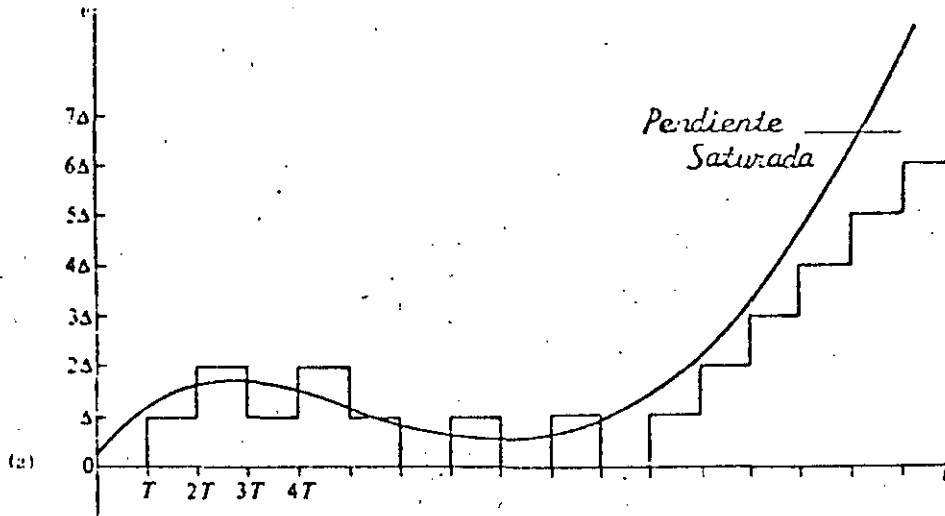


FIGURA N° 17

SEÑALES EN UN SISTEMA DE MODULACION DELTA :

- a) Señal analógica de entrada y su reconstrucción.
 b) Señal modulada en delta.

Para poder transmitir los trenes de pulsos a través de enlaces por altas frecuencias, una portadora continua puede modularse en amplitud, fase o frecuencia en el sistema transmisor, ya que las características de transmisión a altas frecuencias son del tipo de banda base. La señal transmitida es primero demodulada en pulsos en la banda de frecuencia de la portadora en el sistema receptor para dar los pulsos PCM en la banda base. Entonces los pulsos digitales binarios, sin distorsión de transmisión en sus formas de ondas, son regenerados por los pulsos demodulados a través del decodificador.

La modulación y demodulación de la portadora de microondas son esenciales en el sistema de radioenlace PCM. Los pulsos binarios antes de la modulación y después de la demodulación son llamados pulsos banda base.

LLAVEO POR CORRIMIENTO DE AMPLITUD (ASK)

Considere una secuencia de pulsos binarios, como se muestra en la Fig. 18. Los 1's hacen que la portadora esté presente y los 0's la hacen ausente.

Es evidente que el espectro de la señal ASK dependerá de la secuencia binaria particular a ser transmitida. La señal ASK es simplemente:

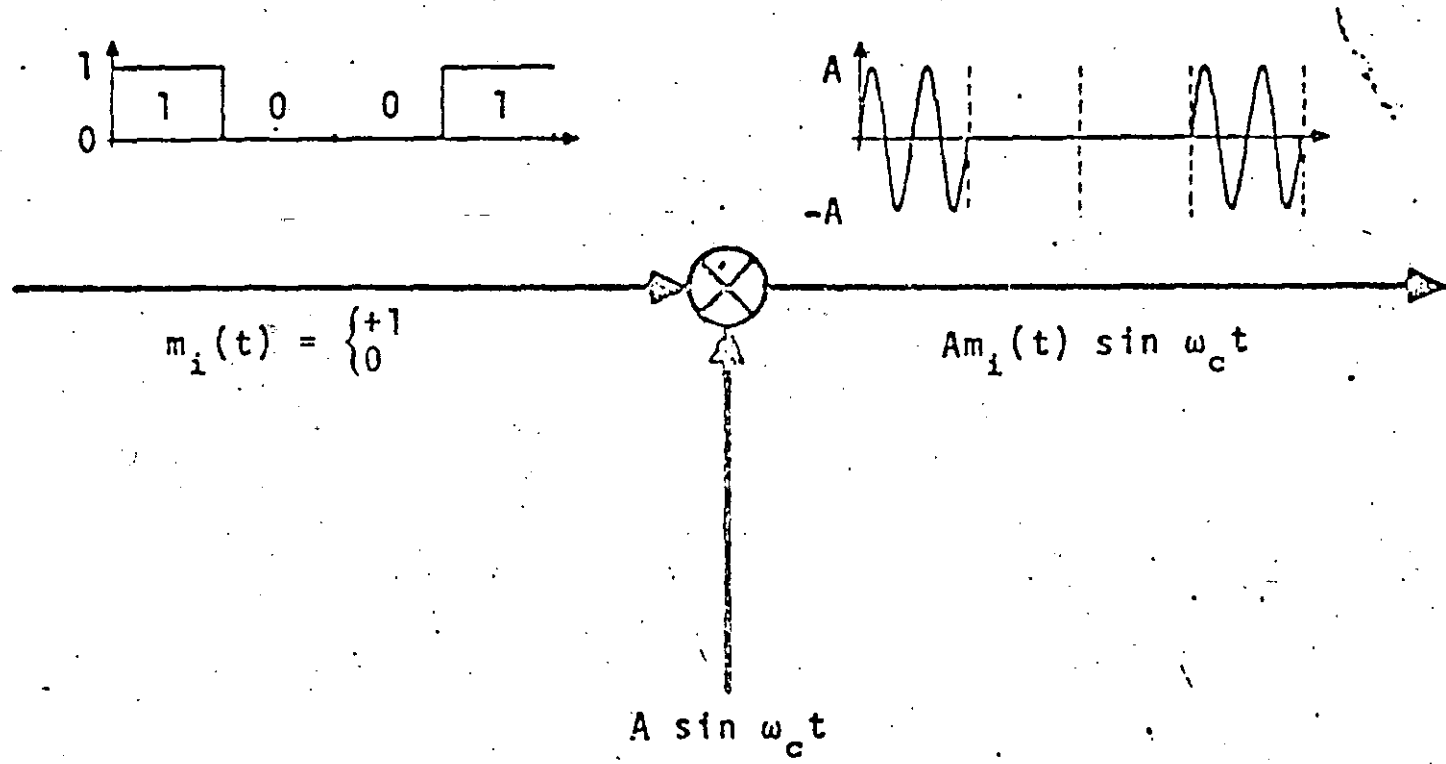


FIGURA N° 18
 MODULACION ASK

$$x_c(t) = x(t) \cos \omega_c t \quad (1)$$

donde $x_c(t) = 1$ ó 0 , sobre un largo intervalo T segundos. Note que esto es exactamente la forma de la señal modulada discutida en capítulos anteriores. Como se mostró, al tomar la transformada de Fourier de la señal modulada en amplitud (ASK) y usando el teorema de desplazamiento de frecuencia, tenemos

$$\bar{x}_c(\omega) = \frac{A}{2} \left[x(\omega - \omega_c) + x(\omega + \omega_c) \right] \quad (2)$$

El efecto de multiplicar por $\cos \omega_c t$ es simplemente defasar el espectro original de la señal binaria (señal de banda base) a la frecuencia ω_c (fig. 19). En realidad esto es la forma general de una señal de AM.

El espectro de la señal modulada (ASK) se muestra en la fig. 20, ya que como se vió anteriormente, es simplemente el espectro de un tren de pulsos esto es $\frac{\text{Sen } X}{X}$.

LLAVEO POR CORRIMIENTO DE FRECUENCIA

Aquí, si consideramos una forma rectangular por simplicidad,

$$\left. \begin{array}{l} x_c(t) = A \cos \omega_1 t \\ \text{ó} \\ x_c(t) = A \cos \omega_2 t \end{array} \right\} -\frac{T}{2} \leq t \leq \frac{T}{2} \quad (3)$$

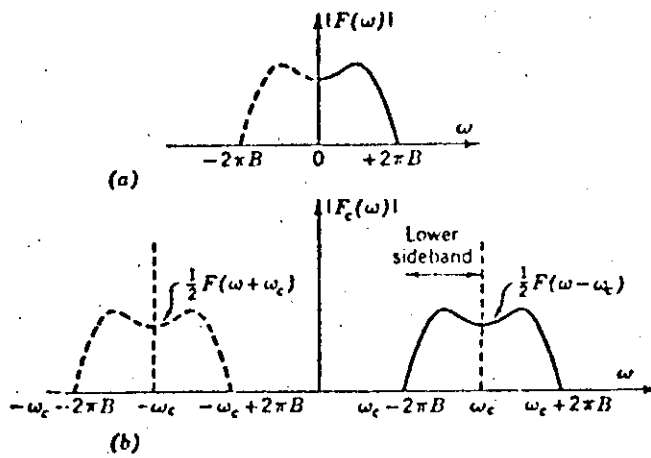


FIGURA N° 19

ESPECTRO DE AMPLITUD:

- a) Espectro de la señal moduladora.
 b) Espectro de la señal modulada.

Un uno corresponde a la frecuencia x_1 , un cero a la frecuencia x_2 (Fig. 21). En algunos sistemas, particularmente sobre líneas telefónicas x_1 y $x_0 = \frac{1}{T}$, pero en general x_1 y $x_2 \gg \frac{1}{T}$. Una representación alternativa de la onda de FSK consiste de hacer $x_1 = x_c - \Delta x$, $x_2 = x_c + \Delta x$. Las dos frecuencias difieren entonces por $2\Delta x$ hertz. Entonces

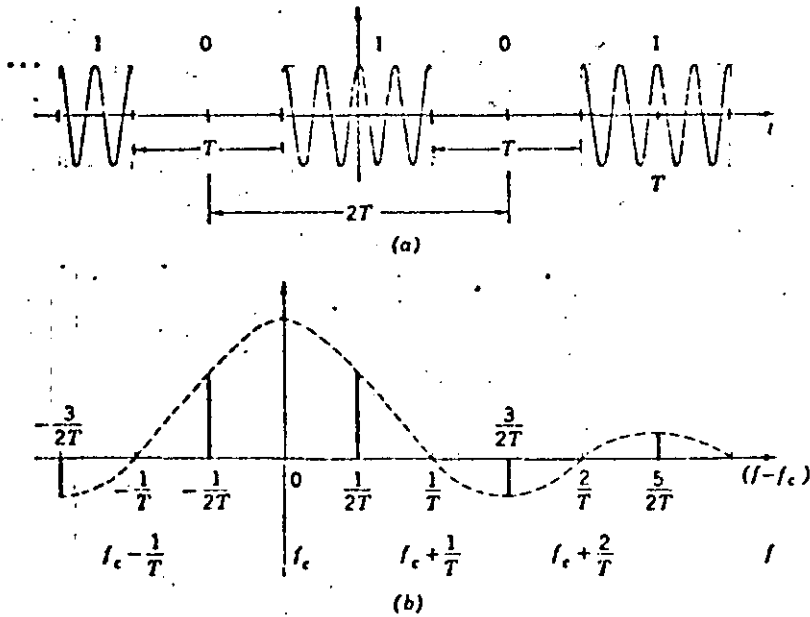
$$x_c(t) = A \cos(\omega_c \pm \Delta\omega) t \quad -\frac{T}{2} \leq t \leq \frac{T}{2} \quad (4)$$

entonces la frecuencia se desvía $\pm\Delta x$ respecto a x_c . Δx es comúnmente la desviación de frecuencia. El espectro de frecuencia para FSK es, en general, difícil de obtener. Debemos de observar que esto es una característica general de señales de FM.

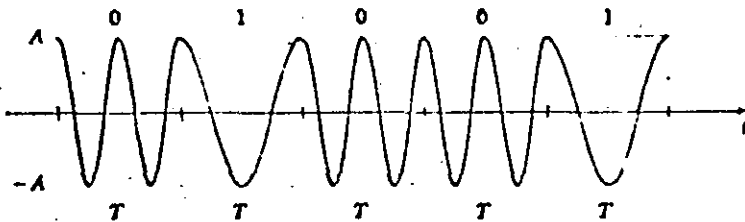
Consideremos que el mensaje binario consiste de una secuencia alternativa de 1's y 0's. Si las dos frecuencias son múltiples por el recíproco del período binario T ($x_1 = m/T$, $x_2 = n/T$, m y n integrados), y son sincronizadas en fase, como se considera en la ecuación (3), la onda FSK es la función periódica de la fig. 22. Note, sin embargo, que esto puede también ser visualizado como la superposición lineal de dos señales periódicas ASK tales como la de la fig. 22, una retrazada T segundos con respecto a la otra.

LLAVEO POR CORRIMIENTO DE FASE

En este caso, tenemos que la señal de llaveo por corrimiento



Espectro de una Señal Periódica OOK: a, Señal Periódica; b) Espectro (frecuencias positivas únicamente).



Señal FSK

FIGURA N° 20

MODULATION - FSK

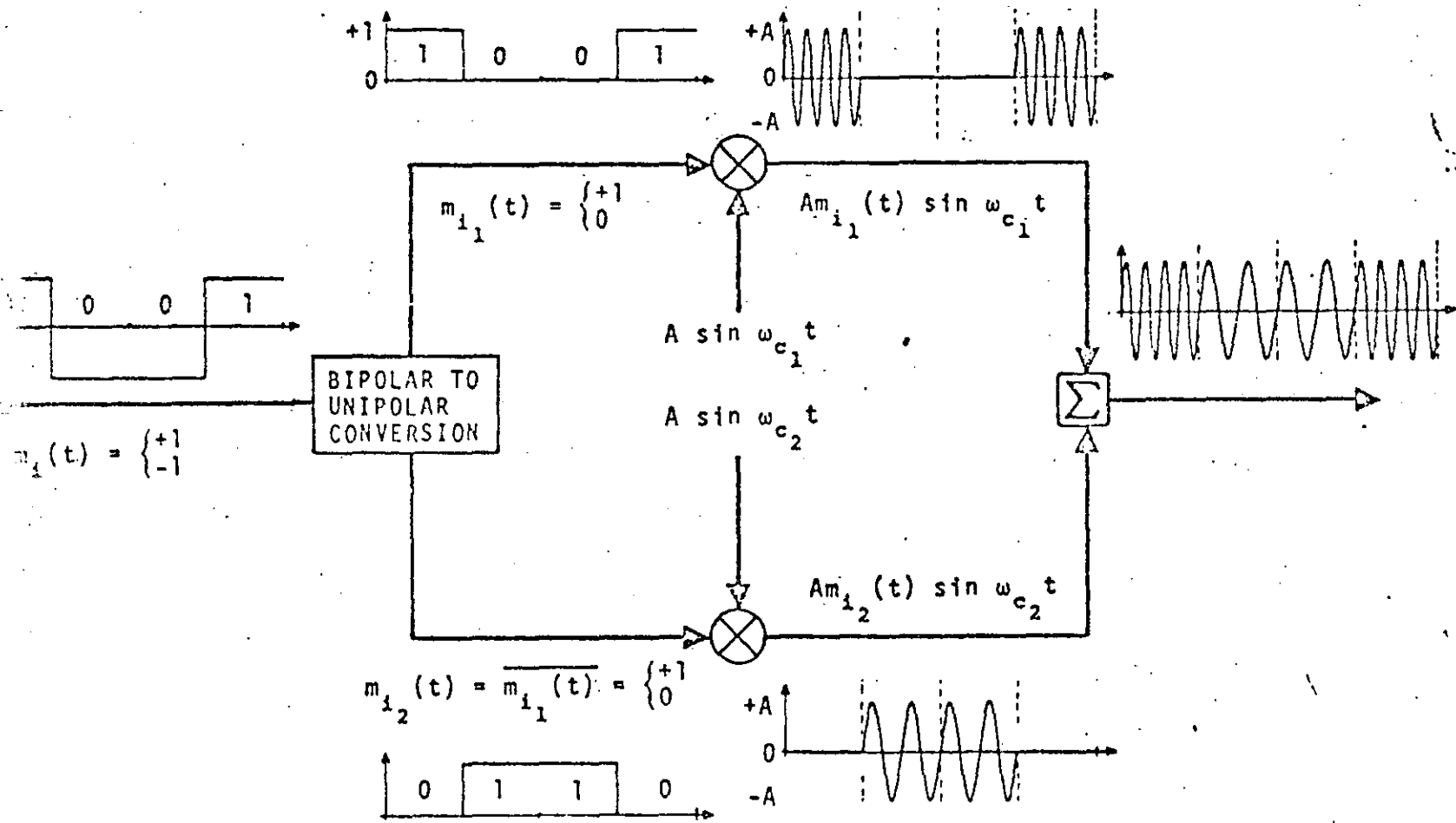


FIGURA N° 21

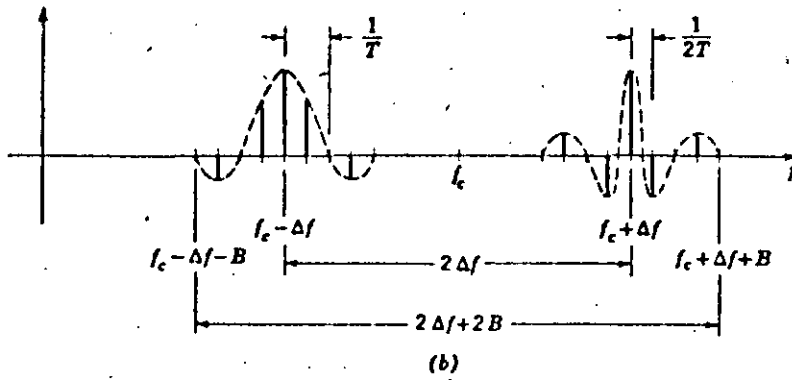
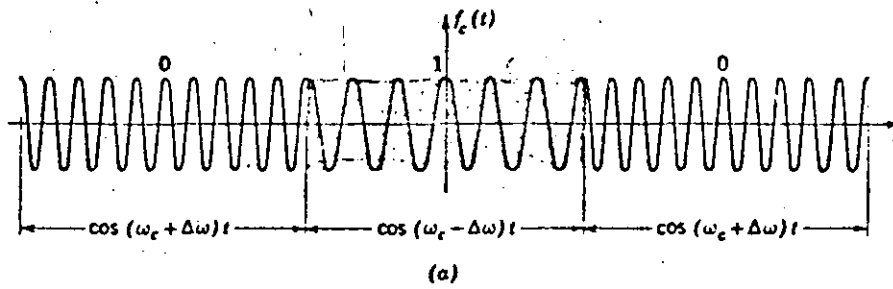


FIGURA N^o 22

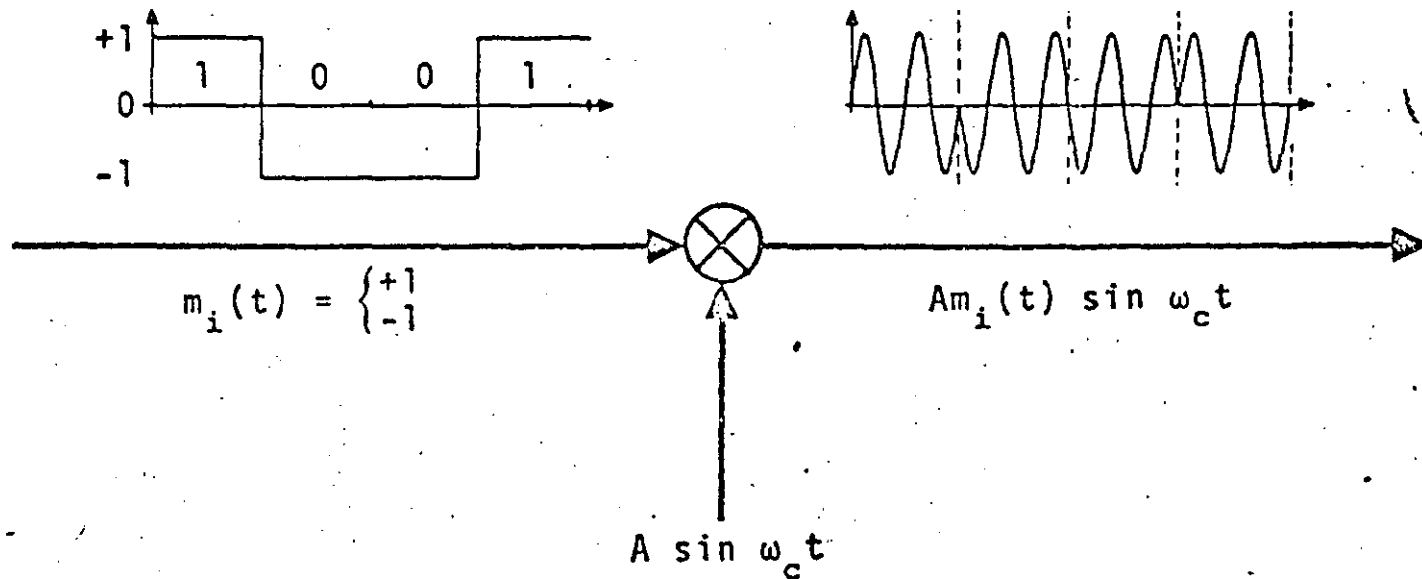
de fase esta dada por 131

$$x_c(t) = \pm \cos \omega_c t \quad -\frac{T}{2} \leq t \leq \frac{T}{2} \quad (5)$$

Si una forma rectangular es asumida. Aquí un 1 en el flujo binario de banda base corresponde a polaridad positiva, y un 0 a polaridad negativa. La señal PSK corresponde esencialmente a un flujo binario sin retorno a cero, como se muestra en la Fig. 23.

Las señales ASK, FSK y PSK pueden producirse por medio de moduladores digitales. Sin embargo, dichos moduladores pueden ser implementados más simplemente alimentando la entrada de datos directamente a un conmutador el cual puede seleccionar la forma de onda de la señal apropiada de una de las dos fuentes de la señal, para así, construir la señal modulada. Moduladores de este tipo son mostrados esquemáticamente en la fig. 24. El modulador ASK representada en la fig. 24a simplemente conmuta una portadora en encendido o apagado. El modulador FSK en la fig. 24b conmuta entre dos señales de diferentes frecuencias. El conmutador de PSK, como se muestra en la fig. 24c, introduce un retraso de duración de medio longitud de onda a la señal del oscilador para que así se produzca un cambio de fase de π en la señal modulada.

MODULATION - PSK



$$\underbrace{A \cos(\omega_c t - m_i(t) \frac{\pi}{2})}_{\text{PSK SIGNAL}} = A \cos \omega_c t \cos \left[\cancel{m_i(t) \frac{\pi}{2}} \right]^0 + A \sin \omega_c t \sin \left[m_i(t) \frac{\pi}{2} \right]$$

$$= \underbrace{Am_i(t) \sin \omega_c t}_{\text{DSB SIGNAL}}$$

FIGURA N° 23.

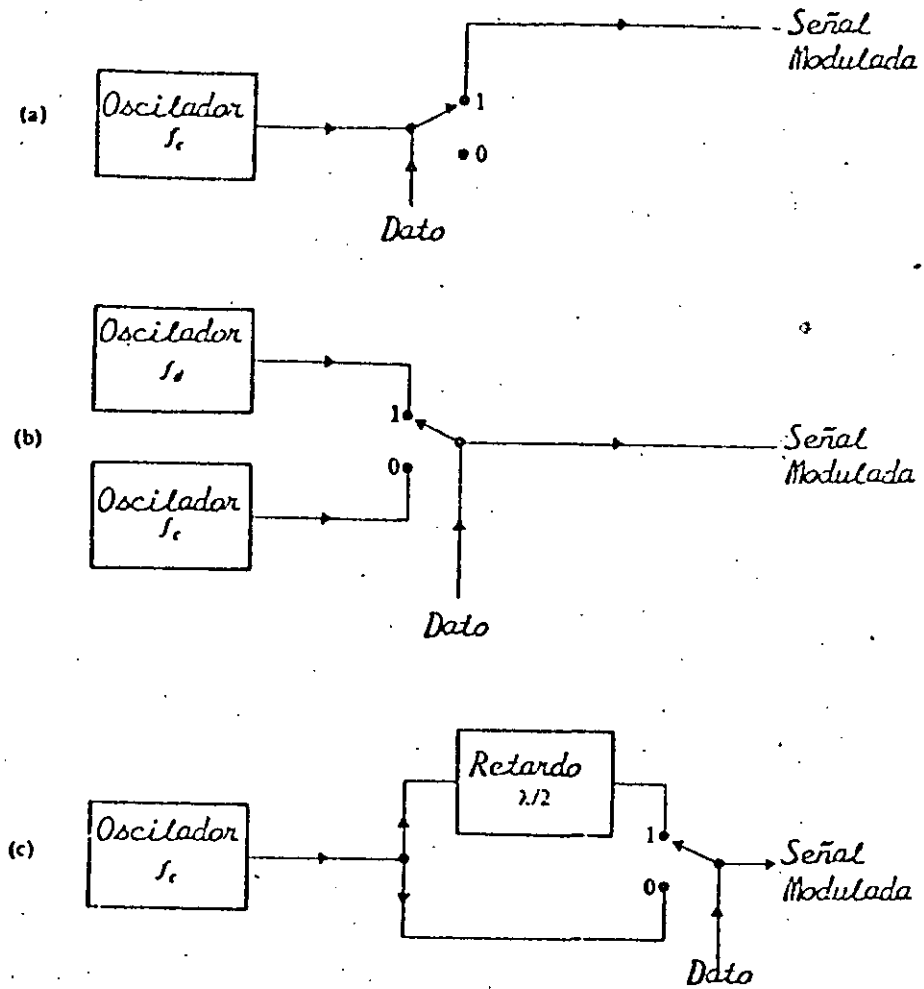
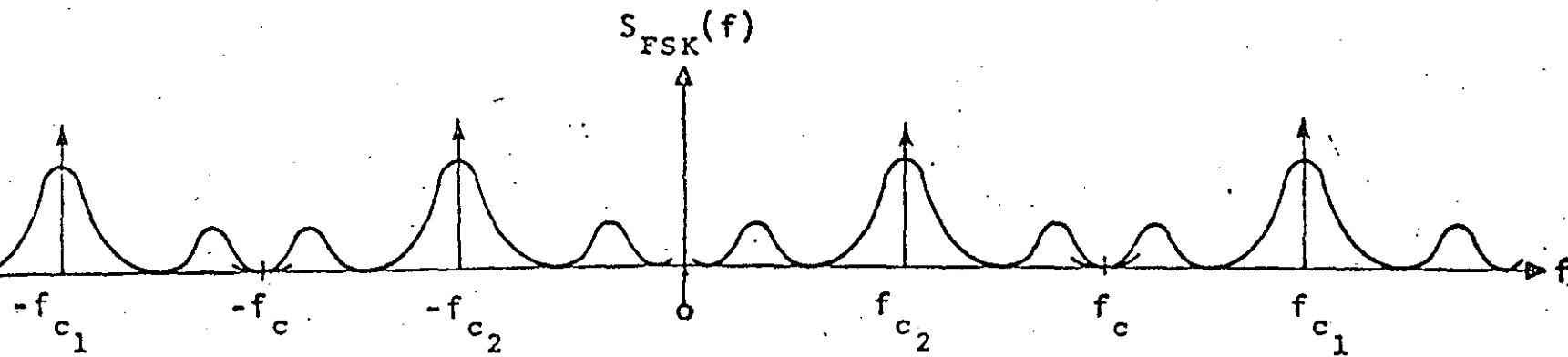
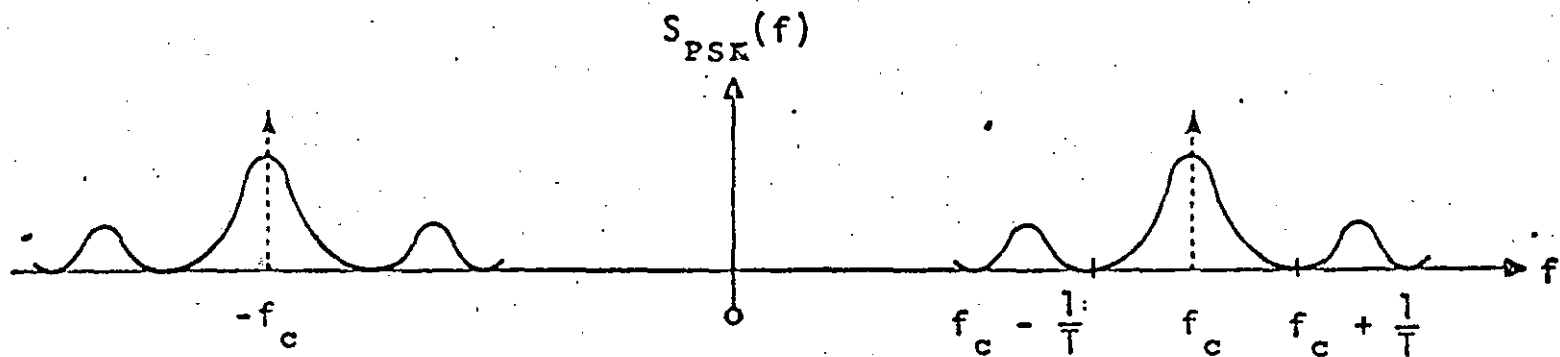
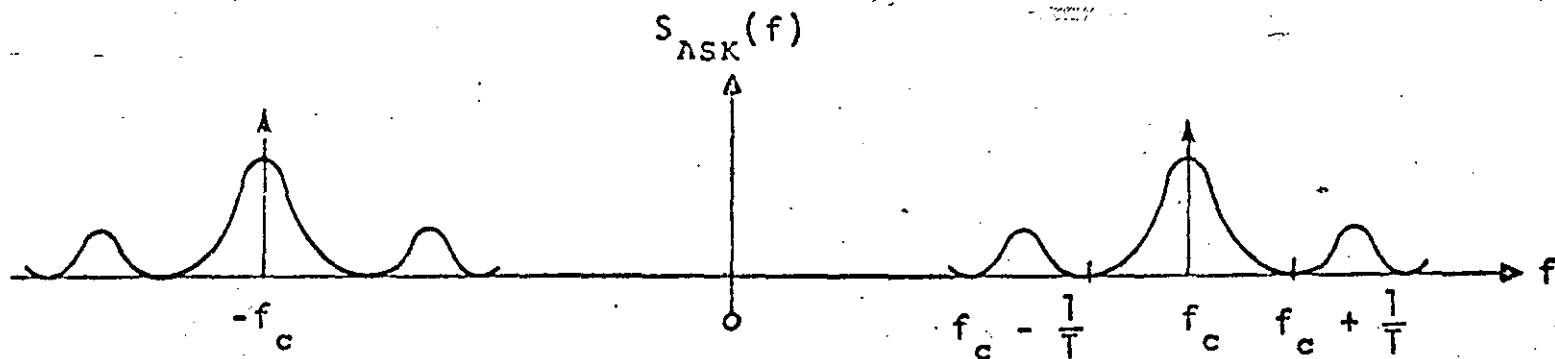


FIGURA N° 24

DIAGRAMA EN BLOQUES DE MODULADORES: a) ASK ; b) FSK ; c) PSK .

ASK, PSK, AND FSK POWER SPECTRA



Cuando la señal modulada es recibida, debe ser demodulada para así recobrar la señal original de dos niveles. Ya que una señal de PSK es tanto $+\cos \omega_c t$ como $-\cos \omega_c t$ en cualquier intervalo, su demodulación puede lograrse al detectar el signo en cada intervalo del tiempo. Esto es enteramente equivalente a detectar su fase. Un demodulador de señales PSK es mostrado esquemáticamente en la figura 24a. Opera al multiplicar la señal de entrada por la señal $\cos \omega_c t$. La señal de referencia debe estar en fase con la portadora sin modular como serie recibida si se transmitiera al receptor. La salida del multiplicador es

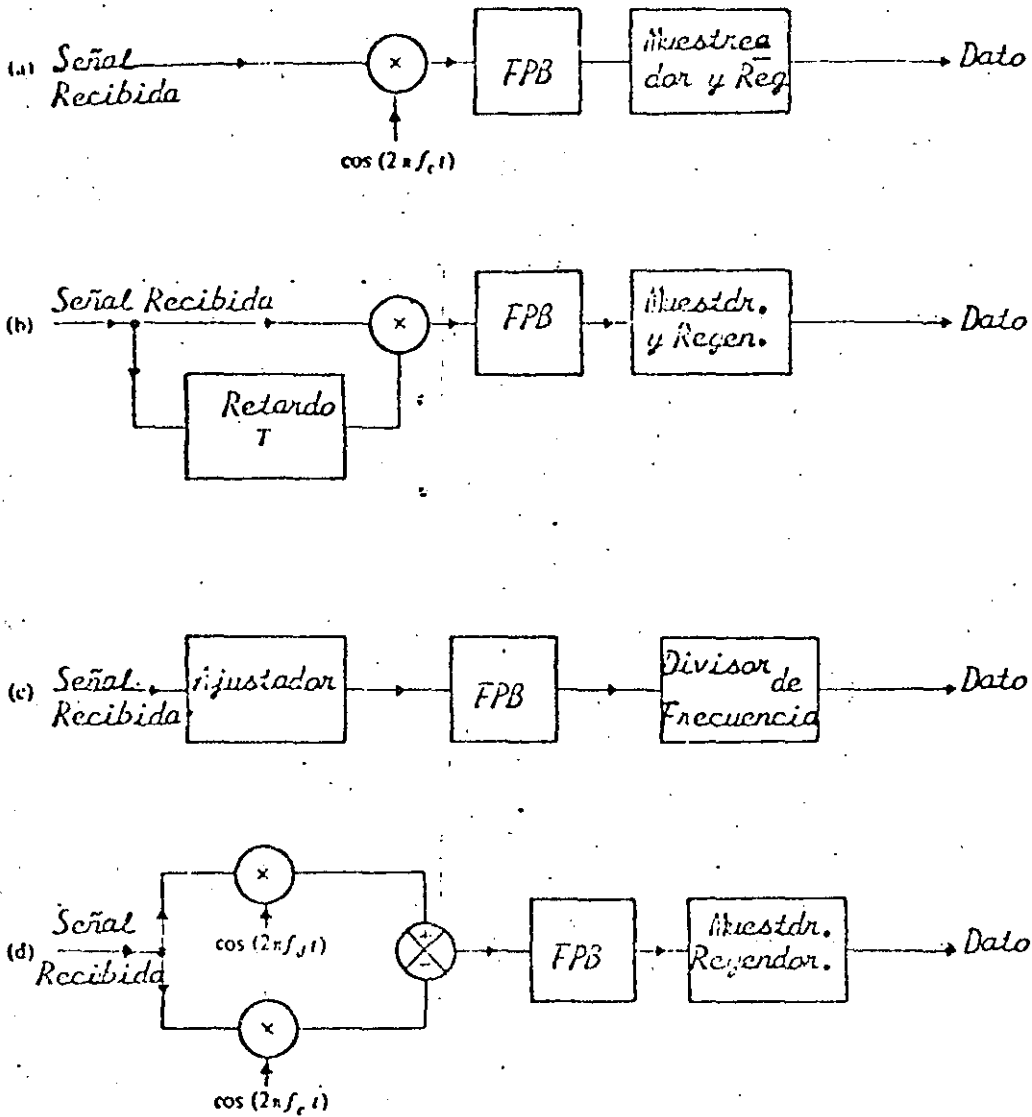
$$\pm x(t) \cos^2 \omega_c t = \pm \frac{x(t)}{2} \left\{ 1 + \cos 2 \omega_c t \right\} \quad (6)$$

donde el signo depende del signo de la señal modulada. Cuando esta señal de salida es filtrada por un filtro para bajas frecuencias obtendremos $\pm x(t)$.

Observese que para ASK, $x(t)$ es 1 ó 0 y para PSK es ± 1 por lo que para ASK utilizamos el mismo diagrama. Este tipo de demodulación es llamada detección síncrona o coherente, debido a que la frecuencia local debe ser igual a la frecuencia de la señal recibida.

Un tipo alternativo de demodulador para señales PSK es el demodulador coherente diferencial (fig. 25b). Este tipo de demodulador evita el uso de señal de referencia al comparar la señal en cada intervalo de tiempo con esa del intervalo

FIGURA N° 25 DEMODULADORES FSK Y PSK



137

de tiempo con esa del intervalo anterior. El diagrama de bloques del demodulador para señales FSK es mostrada en la fig. 25c. Este demodulador requiere dos señales de referencia como se muestra.

En cualquier intervalo de tiempo la señal de FSK es tanto $\cos \omega_d t$ como $\cos \omega_c t$, y un análisis similar al que se hizo para PSK muestra que la entrada al filtro paso-bajas es tanto

$$x(t) \cos^2 \omega_d t = x(t) \cos \omega_d t \cos \omega_c t$$

ó

(7)

$$x(t) \cos \omega_d t \cos \omega_c t - x(t) \cos^2 \omega_c t$$

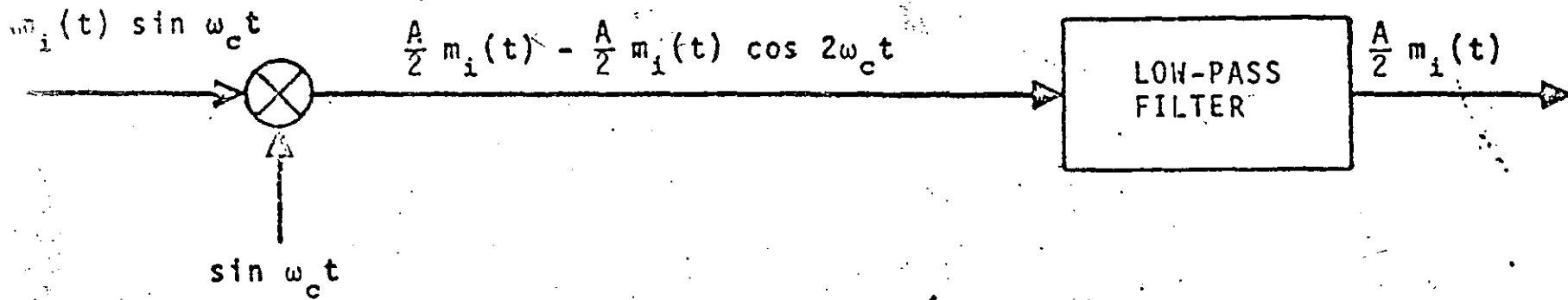
de tal forma que a la salida del filtro tendremos solamente $f(t)$.

La otra forma común de detección, detección de envolvente, evita problemas de tiempo y de fase de la detección síncrona, Aquí la señal de entrada de alta frecuencia pasa a través de un dispositivo no lineal y un filtro para bajas (fig. 26). Sin embargo existe una desventaja. La señal PSK tiene una envolvente constante (fig. 23). tal que no puede usarse un detector de envolvente. Así que el sistema PSK requiere detección síncrona.

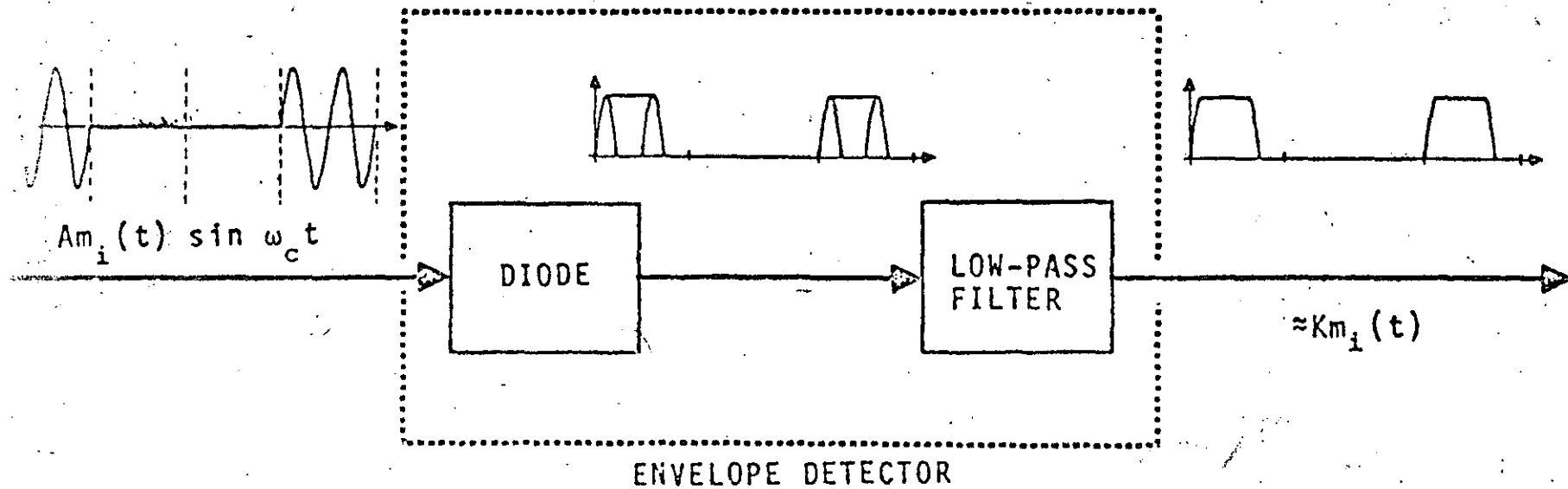
Para concluir la discusión de señalización binaria, mostramos en la fig. 26a un diagrama completo de un sistema PCM.

DEMODULATION - ASK

COHERENT

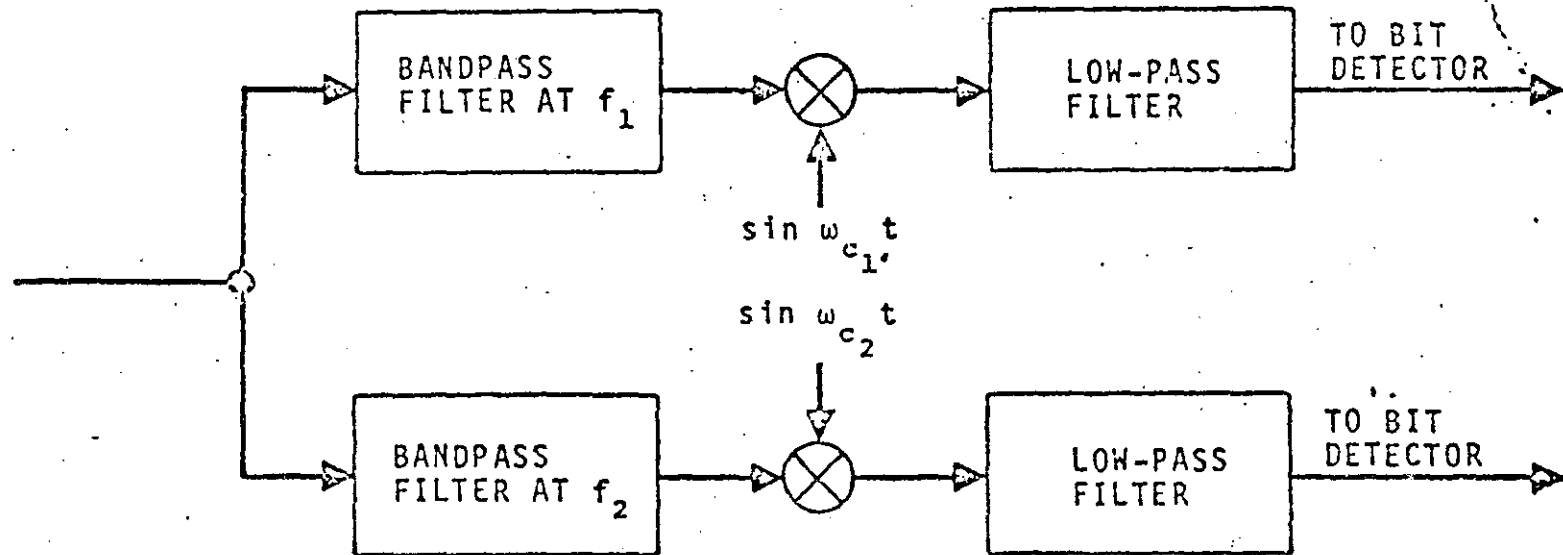


INCOHERENT



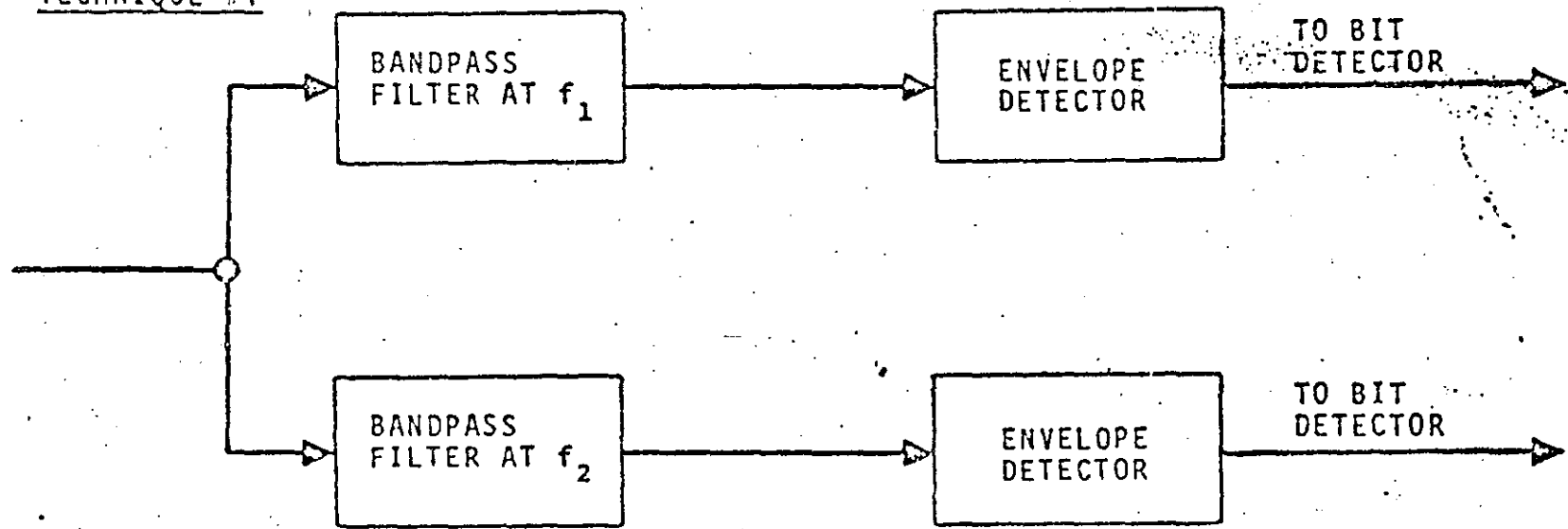
130.
138

COHERENT DEMODULATION - FSK

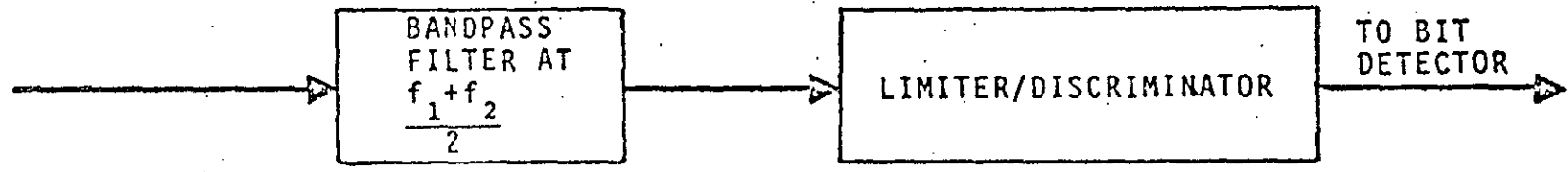


INCOHERENT DEMODULATION - FSK

TECHNIQUE #1

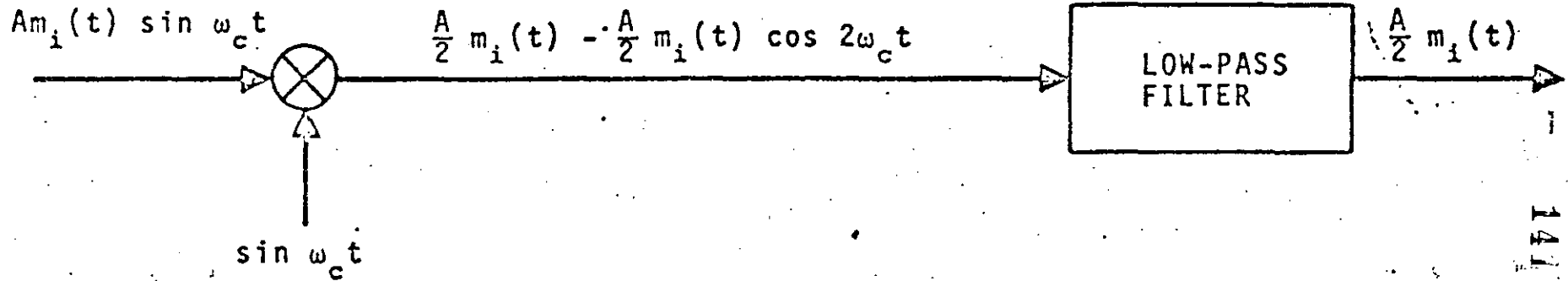


TECHNIQUE #2

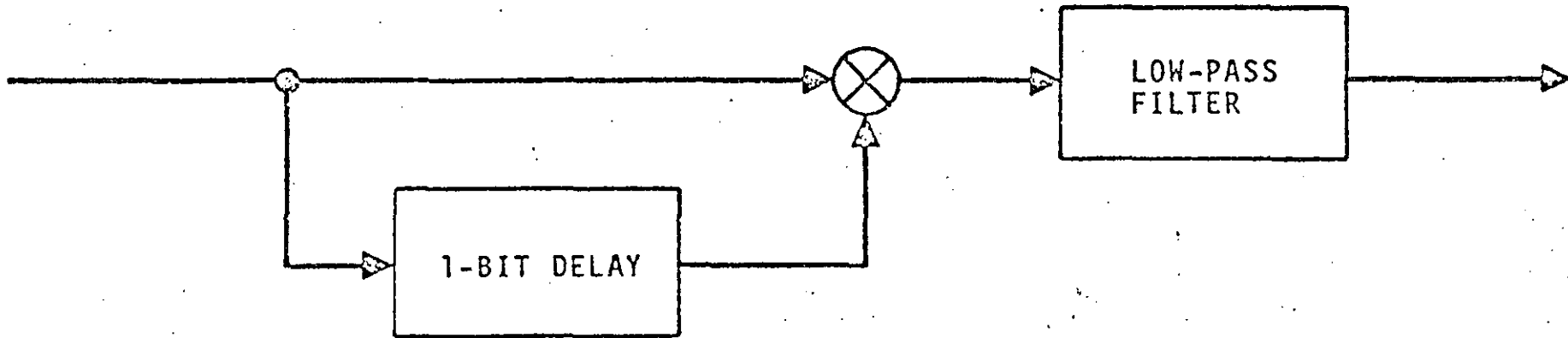


DEMODULATION - PSK

COHERENT



DIFFERENTIALLY COHERENT



BINARY SIGNALING

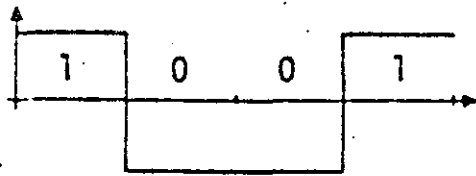
FROM
SOURCE
OR CHANNEL
ENCODER

$m_i(t)$

MODULATOR

$s_i(t)$

TO
CHANNEL

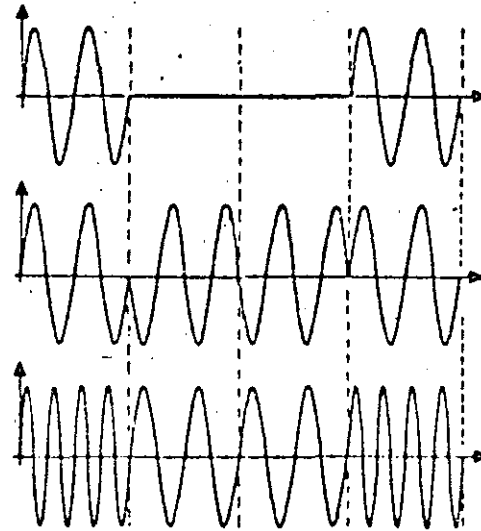


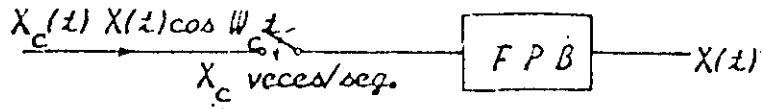
{AM
PM
FM}

ASK

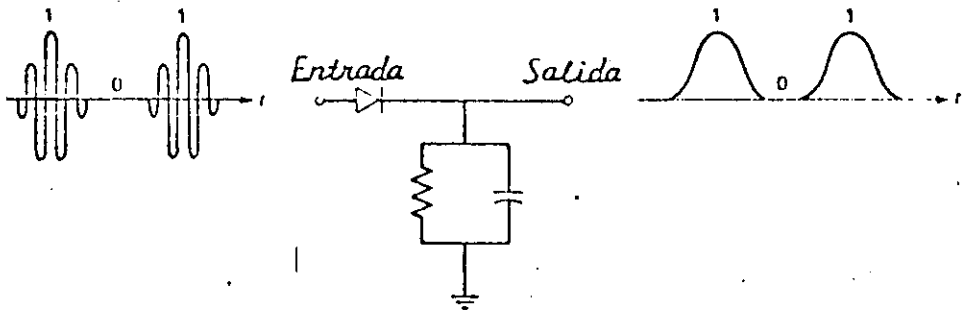
PSK

FSK





Detector Síncrono



Detector de Envolverte

FIGURA N° 26

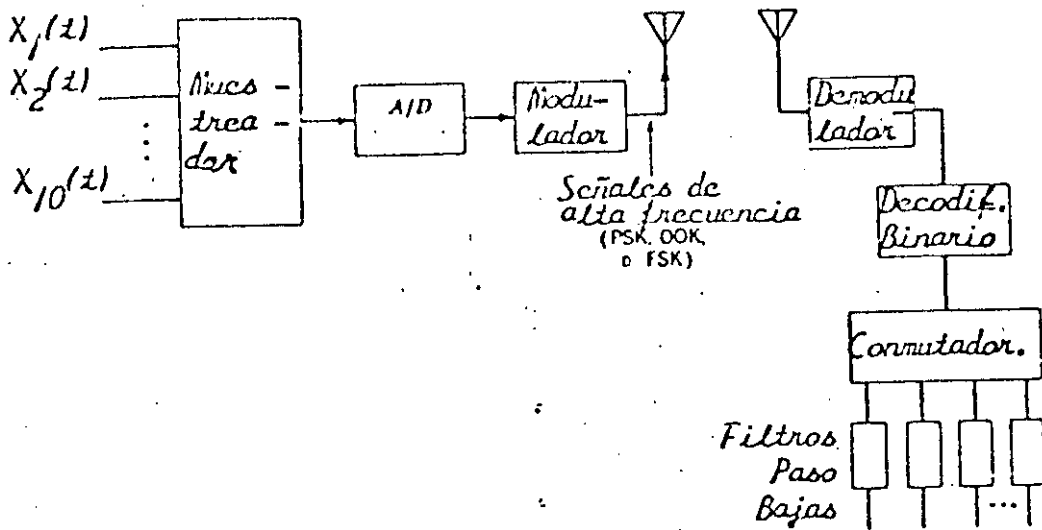


FIGURA N° 26 a:
Sistema PCM Completo

Este incluye la circuitería A/D, el modulador, el cual produce las señales binarias de alta frecuencia, en el receptor, el demodulador, el cual incluye un detector síncrono ó de envolvente, un decodificador binario, un conmutador, o circuito de conmutación para ordenar las señales multiplicadas en el tiempo, y finalmente un filtro paso bajas, a la salida de cada canal, para proveer las señales de salida finales.

TECNICAS DE MODULACION PARA COMUNICACIONES DIGITALES: SEÑALIZACION MULTISIMBOLA.

En las secciones anteriores hemos puesto nuestra atención en las formas más simples de sistemas de portadora digitales, esas que involucran modulación binaria en amplitud, fase o frecuencia. En los sistemas PCM vimos que los requerimientos de ancho de banda estaban ligadas con la relación de Nyquist. Se vió que si un conjunto de $M = 2^n$ símbolos, es usado, con n el número de dígitos binarios sucesivos combinados para formar el símbolo apropiado para ser transmitido, $2n$ bits/s/Hz pueden ser transmitidos utilizando la banda de Nyquist.

En esta parte, discutiremos específicamente esquemas de señalización de multifase, multiamplitud y multifase/multiamplitud combinadas como ejemplos de sistemas multisímbolos. Estos sistemas no son otra cosa más que una combinación sucesiva de pulsos binarios para formar un pulso más largo que requiere un ancho de banda menor, como primer ejemplo de un

ESQUEMA MULTISIMBOLO

Considere un sistema en el cual dos pulsos sucesivos binarios se combinan y el conjunto resultante de cuatro pares binarios, 00, 01, 10, 11, se usa para generar una onda senoidal de alta frecuencia de cuatro posibles fases, una por cada par binario. Esto es una extensión obvia para transmisión PSK binaria de cuatro fases. La i -ésima señal, de las cuatro posibles, puede escribirse

$$S_i(t) = \cos(\omega_c t + \theta_i)$$

$$i = 1, 2, 3, 4 \quad -\frac{T}{2} \leq t \leq \frac{T}{2} \quad (8)$$

con forma rectangular considerada hasta este punto por simplicidad. Así, esto extiende la representación binaria de la ecuación (5).

Las posibles elecciones para los cuatro ángulos de fase son

$$\theta_i = 0, \pm \frac{\pi}{2}, \pi \quad (9)$$

$$\theta_i = \pm \frac{\pi}{2}, \pm \frac{\pi}{4} \quad (10)$$

En ambos casos las fases son espaciadas $\pi/2$ radianes.

Las señales de este tipo son llamadas PSK cuaternario (QPSK).

Estas señales son un caso especial de multi-PSK (MPSK). Las señales PSK son algunas veces clasificadas también como BPSK.

En general, como ya se dijo, n pulsos binarios sucesivos son acumulados y uno de los $M = 2^n$ símbolos es retirado. Si la razón binaria es R bits/s, cada intervalo de pulso binario es $\frac{1}{R}$ segundos.

El símbolo correspondiente de salida es entonces $T = \frac{n}{R}$ segundos.

Las señales de la ecuación (8) pueden ser representadas, por expansión trigonométrica, en la forma siguiente:

$$S_i(t) = a_i \cos w_c t + b_i \text{ sen } w_c t : -\frac{T}{2} \leq t \leq \frac{T}{2} \quad (11)$$

para el caso de la ecuación (9), en que los pares (a_i, b_i) sean dados, correspondiendo respectivamente a los ángulos

$\theta_i = 0, -\frac{\Pi}{2}, \Pi,$ y $\frac{\Pi}{2}$, por

$$(a_i, b_i) = (1, 0), (0, 1), (-1, 0), (0, -1) \quad (12)$$

El correspondiente conjunto de (a_i, b_i) para (10), esta dado por

$$(\sqrt{2} a_i, \sqrt{2} b_i) = (1, 1), (-1, 1), (-1, -1), (1, -1) \quad (13)$$

La transmisión de este tipo es frecuentemente llamada transmisión de cuadratura, con dos portadoras en cuadratura de fase una a otra ($\cos w_c t$ y $\text{sen } w_c t$) transmitidas simultáneamente sobre el mismo canal.

Es útil representar las señales de (11) en un diagrama de dos dimensiones al localizar los diferentes puntos (a_i, b_i) . El eje horizontal correspondiente a la localización de a_i es llamado componente en fase y el vertical, en el cual b_i esta localizada se llama componente en cuadratura. Las cuatro señales de (12) se muestran en la fig. 27a., las de la ec. (13) se ilustran en la fig. 27b.

La representación en fase (coseno) y en cuadratura (seno) de las señales QPSK $s_i(t)$ sugiere un posible camino de generar estas señales. Dos pulsos de entrada binarios sucesivos son acumulados y el par de números (a_i, b_i) , tomados cada $T = \frac{2}{R}$ segundos, es utilizado para modular dos términos de portadora en cuadratura, $\cos w_c t$ y $\sin w_c t$, respectivamente, donde uno de los números es cero, esa portadora esta de seguro imposibilitada. Un modulador de este tipo es mostrado en la fig. 28.

Es evidente que la demodulación es llevada a cabo al usar dos detectores síncronos en paralelo, uno en cuadratura con el otro. Un diagrama de bloques de tal demodulador aparece en la fig. 29.

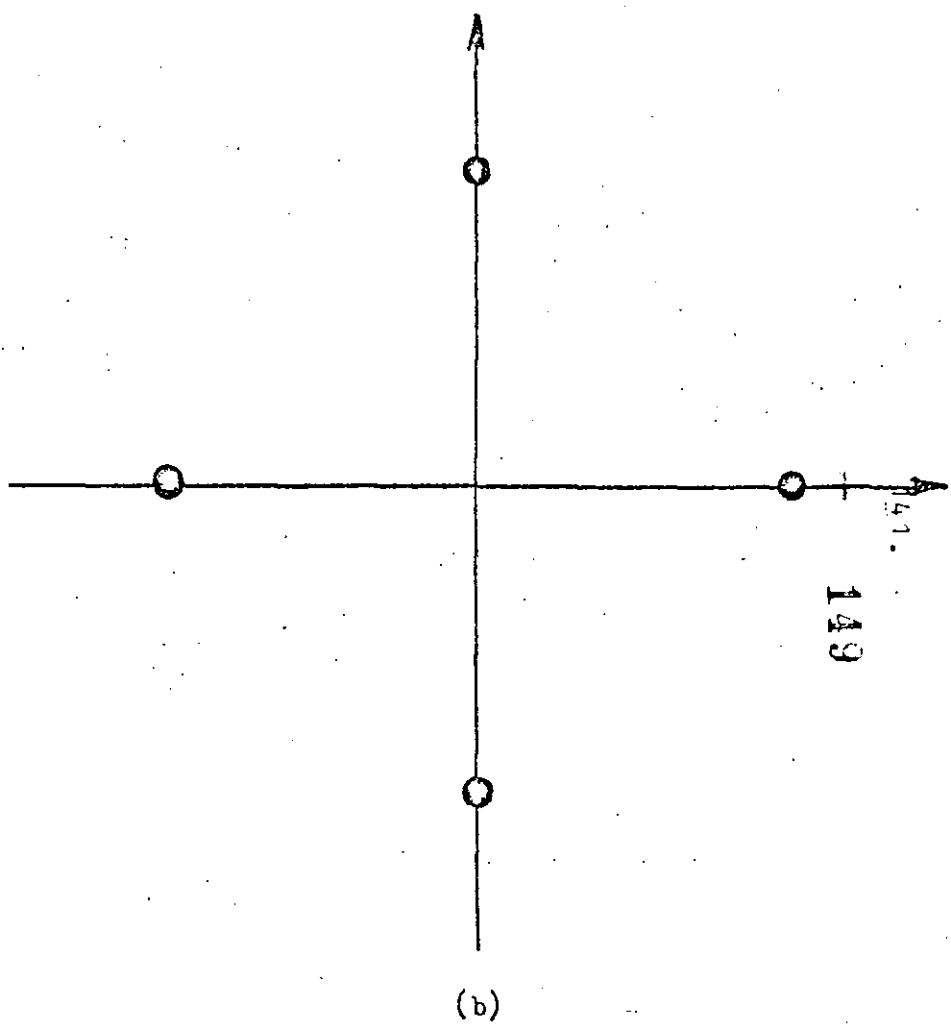
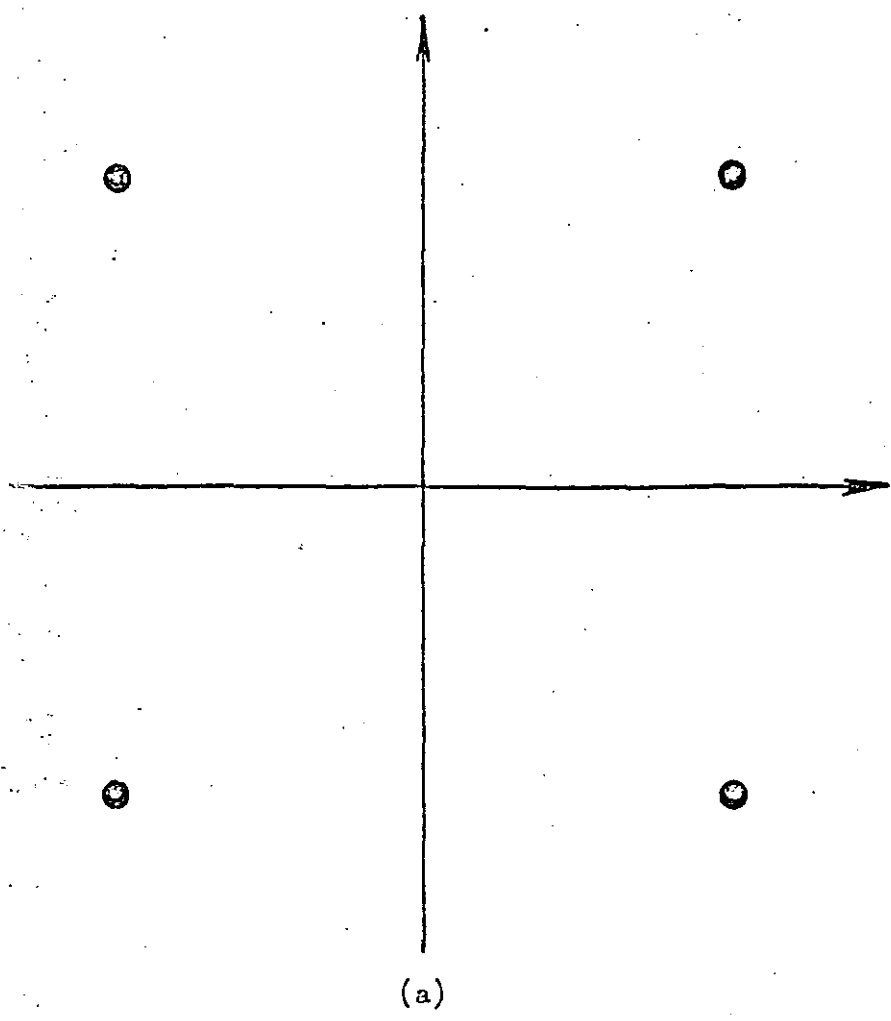
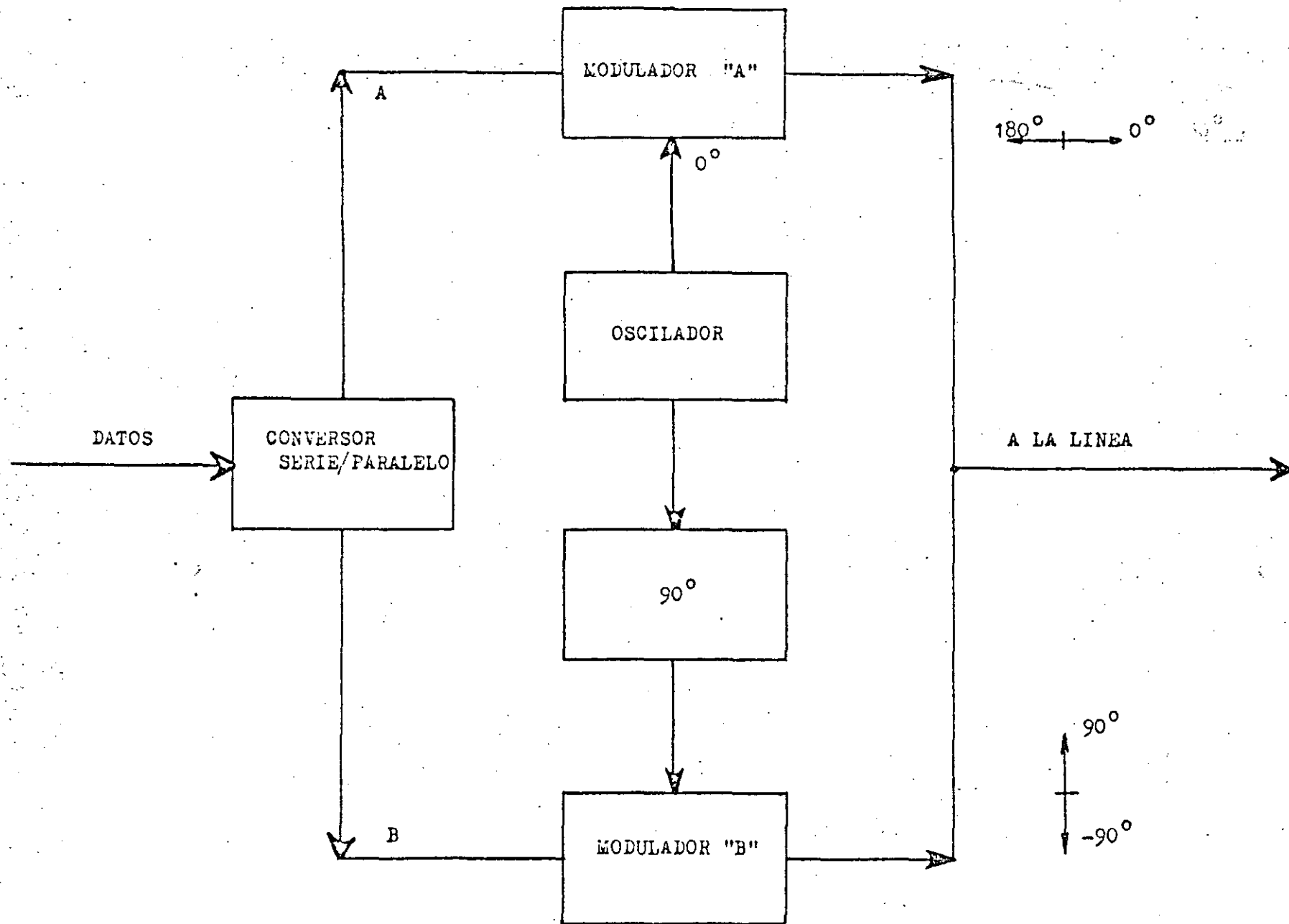


FIGURA No. 27
CONFIGURACION DE SEÑALES QPSK.



142. 150

FIGURA No. 28
 GENERACION DE SEÑALES QPSK

SEÑALIZACION MULTISIMBOLA

01

00, 01, 10, 11 \longrightarrow PSK

$$S_i(t) = \cos(\omega_c t + \theta_i)$$

$$i = 1, 2, 3, 4 \quad -T/2 \leq t \leq T/2$$

$$\theta_i = 0, \pm \pi/2, \pi$$

$$\theta_i = \pm \pi/4, \pm \frac{3\pi}{4}$$

$$S_i(t) = a_i \cos \omega_c t + b_i \sin \omega_c t$$

$$\text{para } \theta_i = 0, -\pi/2, \pi, \pi/2$$

$$(a_i, b_i) = (1,0), (0,1), (-1,0), (0,-1)$$

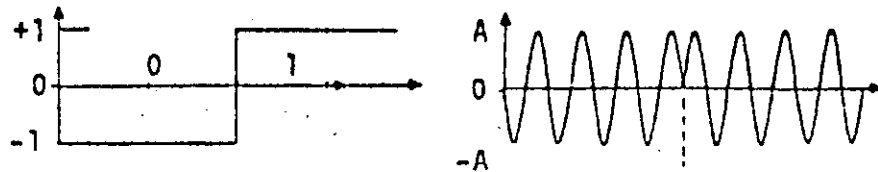
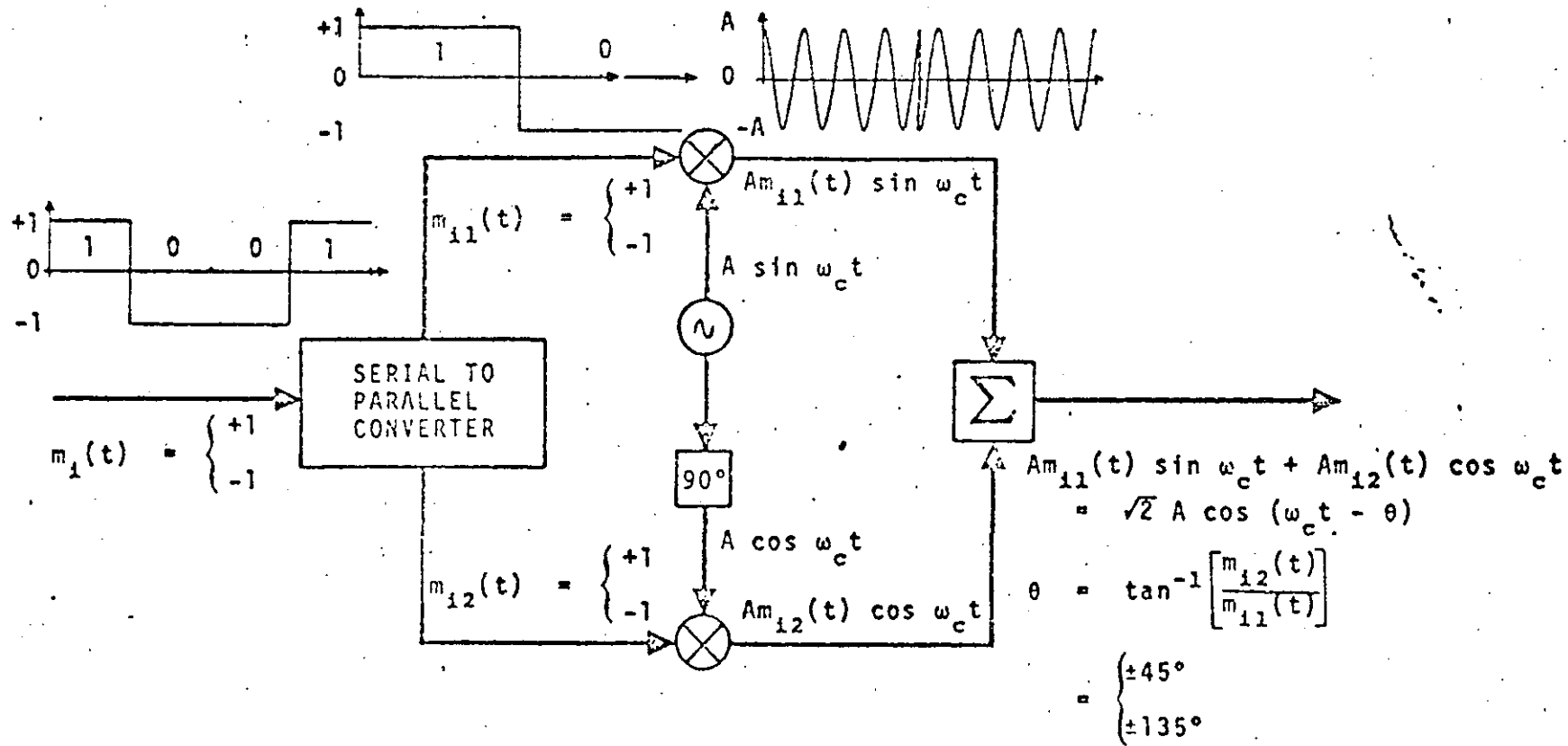
$$\text{para } \theta_i = \frac{\pi}{4}, -\frac{\pi}{4}, \frac{3\pi}{4}, -\frac{3\pi}{4}$$

$$(\sqrt{2} a_i, \sqrt{2} b_i) = (1,1), (-1,1), (-1,-1), (1,-1)$$

→ PSK Cuaternaria (QPSK)

→ Caso especial de PSK Multiple (MPSK)

QUADRI-PHASE MODULATION



Más tipos generales de esquemas de señales de múltiple nivel pueden ser generadas dejando que a_i y b_i en (11) tomen múltiples valores.

Las señales resultantes son llamadas señales de modulación en amplitud en Cuadratura. Estas señales pueden interpretarse como que tienen modulación en amplitud de múltiple nivel aplicada independientemente en cada una de las dos portadoras de cuadratura. El demodulador de la fig. 29 con un detector síncrono, puede entonces usarse para recobrar la información digital deseada.

SISTEMAS 8-PSK

La técnica de modulación 8-PSK puede ser vista como una extensión del sistema QPSK. En el diagrama de bloques del modulador clásico 8-PSK mostrado en la fig. 30., la tasa de datos f_b es dividida en tres flujos paralelos binarios, cada uno teniendo una tasa de transmisión de $f_b/3$. El convertidor de 2 niveles a cuatro produce uno de los cuatro posibles niveles de una señal polar de banda base en a y b . Si el símbolo binario A es un lógico (cero), entonces el nivel de salida a tiene uno de los dos posibles estados (positivo ó negativo). El estado lógico del bit C determina si el nivel más largo ó más pequeño de la señal debe estar presente en a ó en b . Cuando $C = 1$, entonces la amplitud de a es mayor que la de b ; si $C = 0$ entonces el proceso inverso es verdadero. Las señales de banda base polares de 4 nive

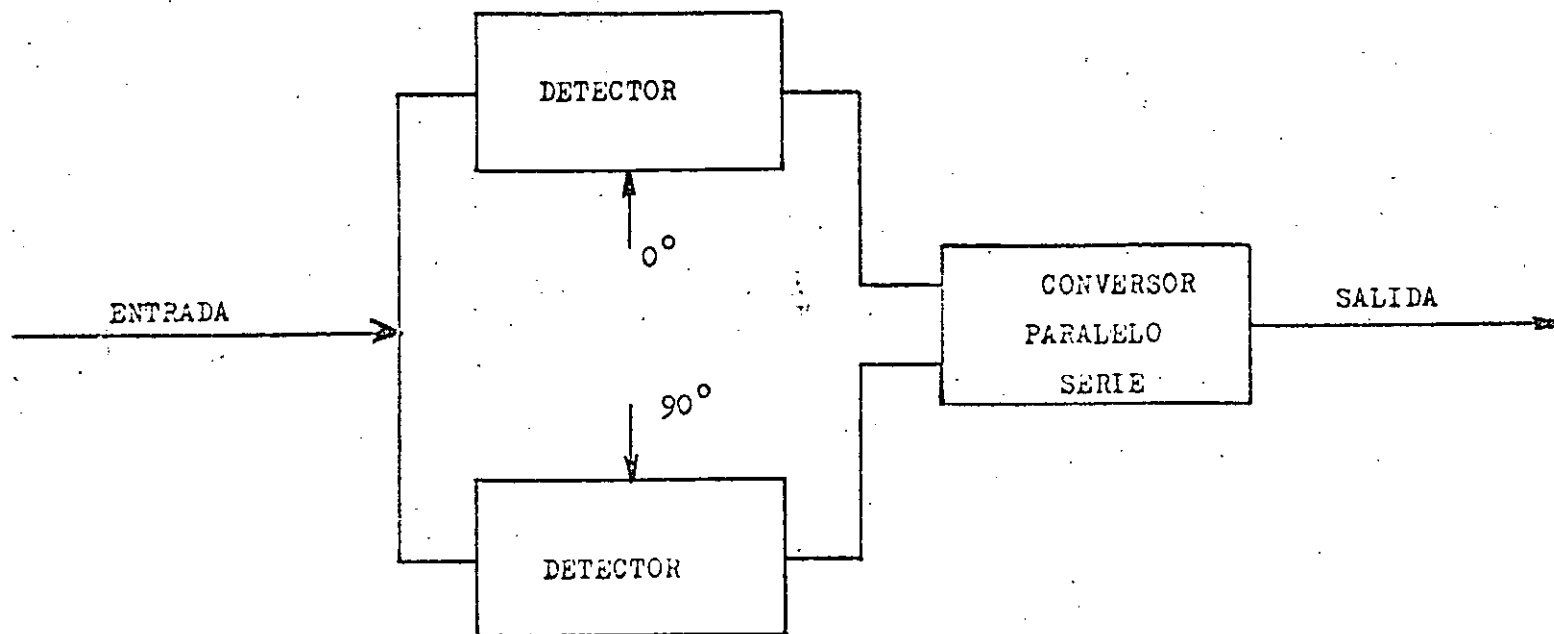


FIGURA No. 29
DEMODULADOR QPSK

147.
133

les en a y b son utilizadas para modular en amplitud (doble banda lateral con portadora suprimida) las dos portadoras en cuadratura.

Una moderna aproximación en el diseño de un modulador 8-PSK para alta velocidad ($90 M_b/s$), usando solamente dispositivos digitales ha sido discutido en referencias. El principio de operación de tal modulador es ilustrado en la fig. 31. La tasa de información binaria de banda base es convertida de serie a paralelo en la unidad distribuidora de datos. Estos flujos paralelos de datos de tasa $f_b/3$ conmutan en encendido o apagado las compuertas lógicas del multicanalizador conmutativo IF de alta velocidad. Dependiendo de los estados lógicos de banda base, uno de los ocho vectores digitales IF es conectado a la salida digital IF.

Esta portadora digital defasada en fase 8 PSK es filtrada por medio de un filtro paso banda convencional; así, una señal 8-PSK limitada en banda es obtenida. La fig. 32 muestra la digitalmente implementada, $90 M_b/s$, 8-PSK tarjeta de circuitería impresa usada por Raytheon Data Systems en sus sistemas de microondas de 6 y 11 GHz.

La constelación para una señal QAM de 11 estados aparece en la fig. 33. Note que esta señal puede considerarse como si se generara por dos señales moduladas en amplitud en cuadratura. Ya que cuatro niveles de amplitud son usados en cada una de las portadoras, la señal es algunas veces refe

rida como una señal QAM de cuatro niveles. Todos los puntos en la constelación son igualmente espaciados.

MODEMS

Los modems han sido ampliamente adoptados para la transmisión de datos digitales sobre varios medios de transmisión. El ejemplo de un modem PSK de cuatro fases para transmisión digital sobre un canal de 38 KHz en el sistema de satélite SPADE es clásico para mostrar la aplicación de los modems. Un diagrama de bloques simplificado de una combinación transmisor-receptor QAM se ilustra en la fig. 34.

Para una tasa de transmisión de alta velocidad sobre la línea telefónica, señalización de niveles múltiples debe de usarse.

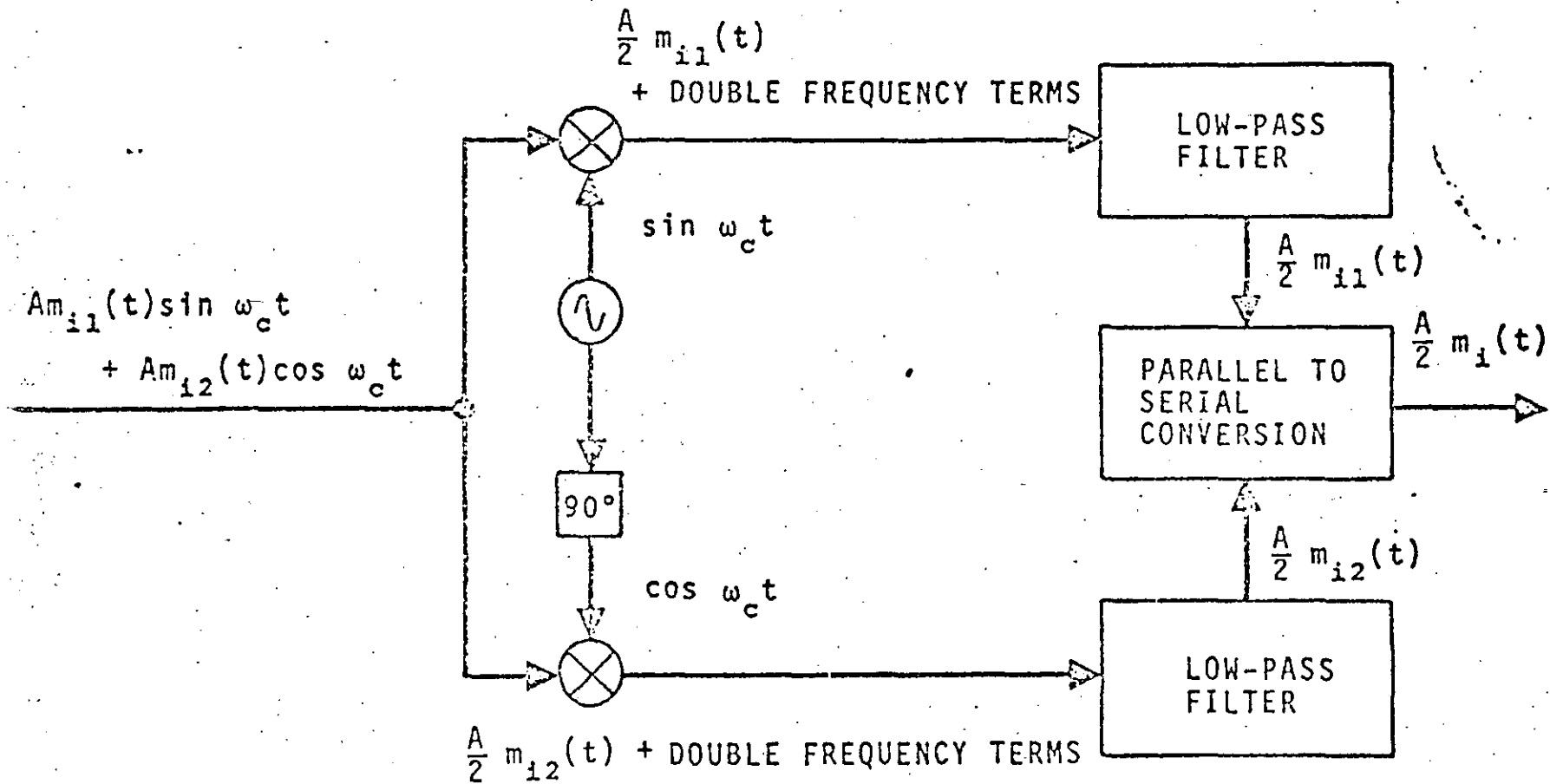
Ejemplos de tres constelaciones y sus correspondientes espectros de transmisión, usados en modems de 2400, 4800 y 9600 bits/s respectivamente, aparecen en la fig. 35. Los espectros de amplitud mostrados están en la escala de decibeles.

EFFECTOS DE RUIDO

Señales de banda base

Un oscilograma típico del voltaje de ruido $n(t)$ se ilustra en la fig. 36. Aunque el ruido es considerado aleatorio, tal que no se pueden especificar por adelantado valores particular de voltaje como una función del tiempo, se puede sin em

QUADRI-PHASE DEMODULATION (COHERENT)



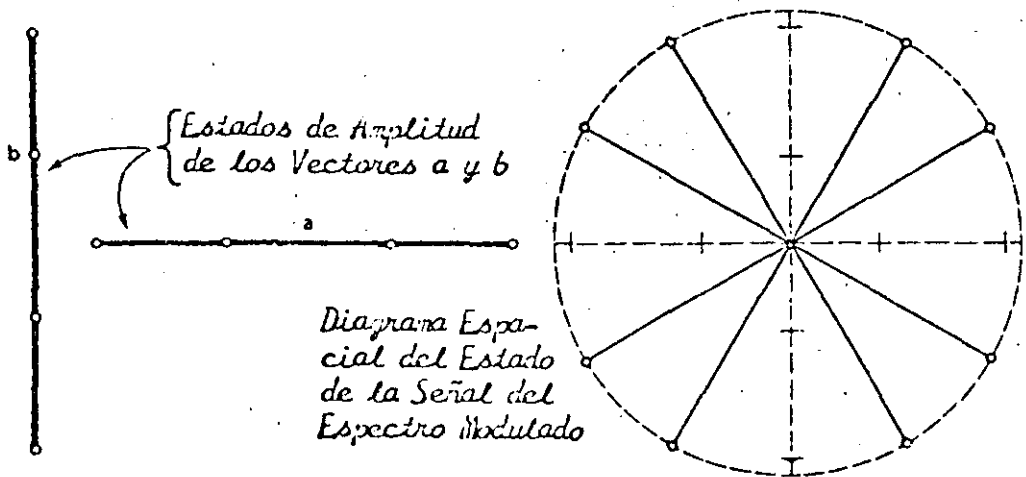
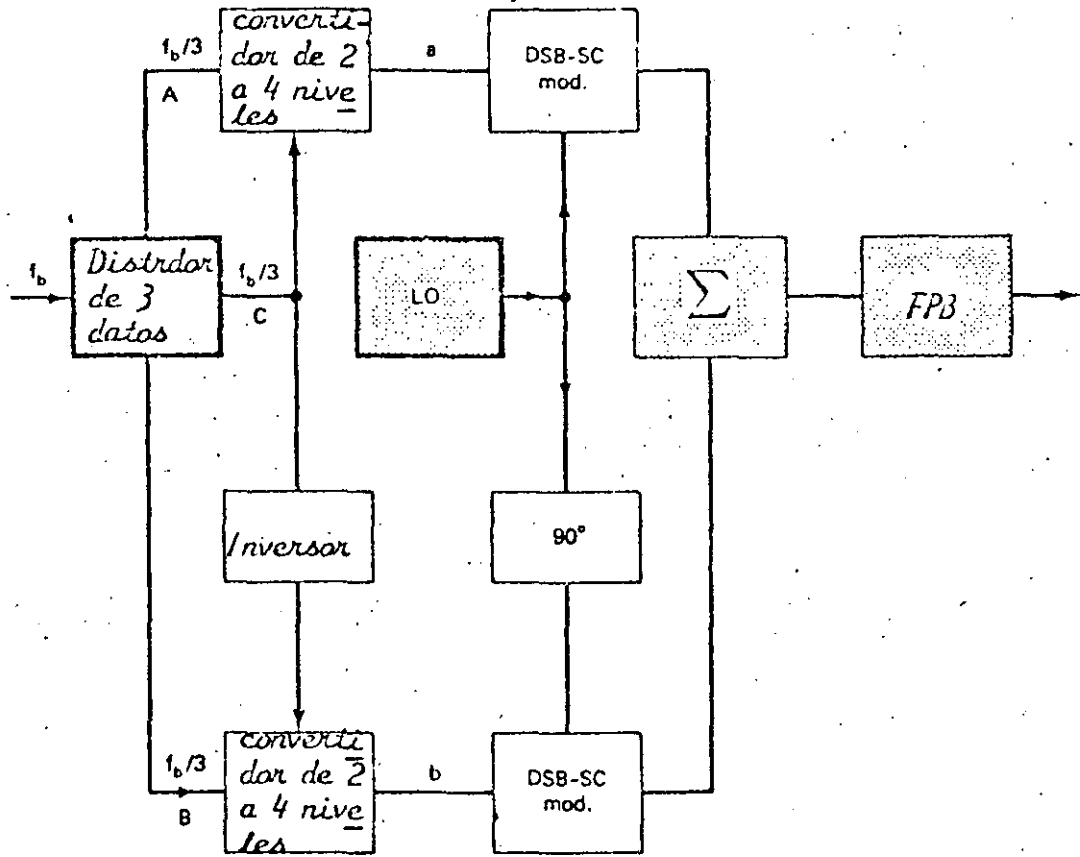


FIGURA N° 30
 Modulador PSK Clásico de 8 Fases y Diagramas de Estados de Amplitud.

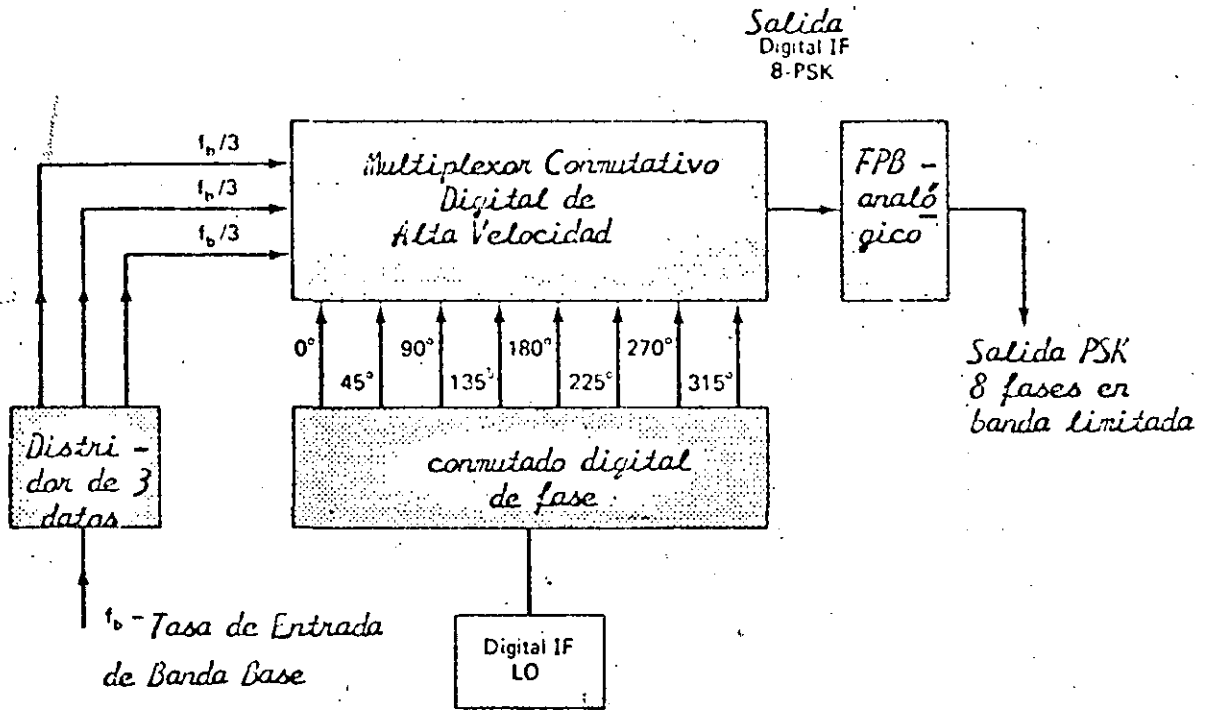


FIGURA N° 31
Modulador PSK de 8 Fases y Alta Velocidad.

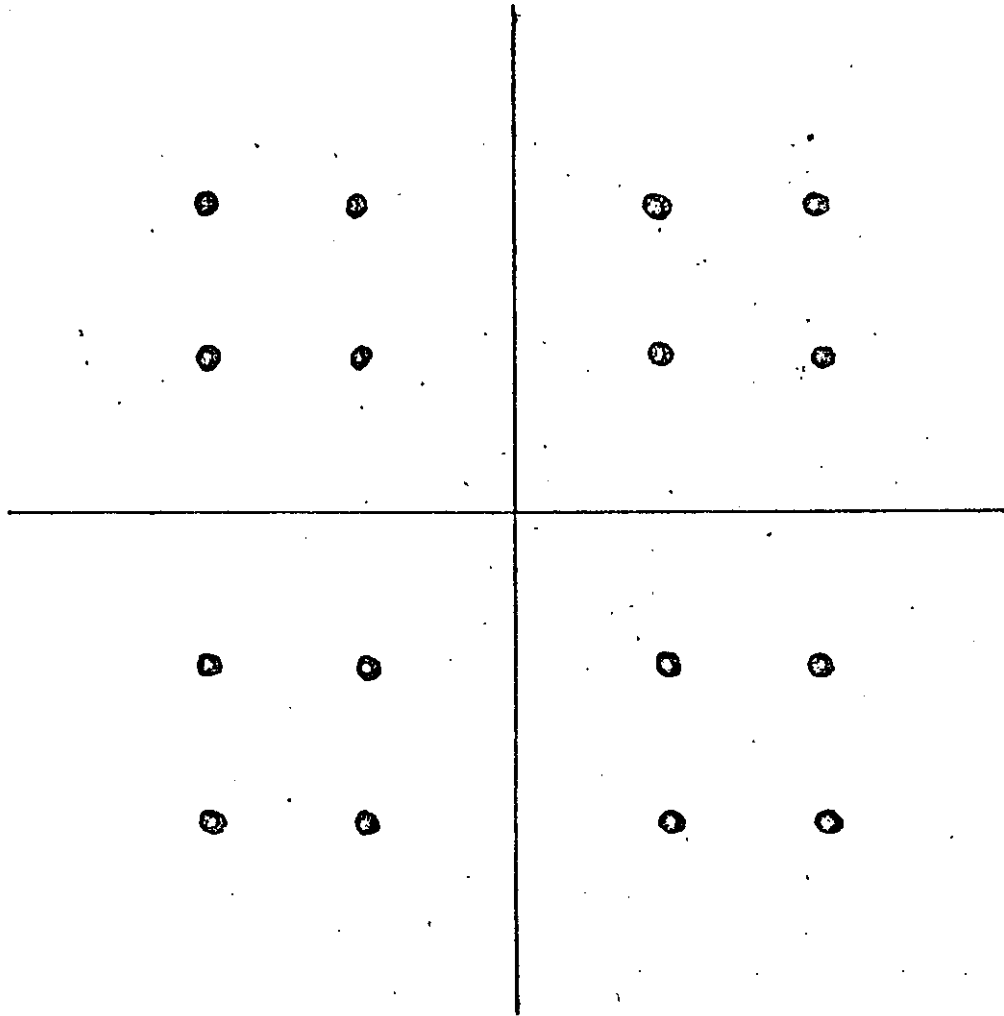


FIGURA No.33

CONFIGURACION QAM DE 4 NIVELES (16-SIMBOLOS)

TECNICA DE MODULACION DIGITAL CONTRA EFICIENCIA ESPECTRAL

TIPO DE MODULACION	NUMERO DE NIVELES LOGICOS	NUMERO DE BITS POR SIMBOLO	ANCHO DE BANDA
A S K	2	1	$B_T = 2B$
F S K	2	1	$B_T = 2B + 2\Delta f$
P S K	2	1	$B_T^b = 2B$
4-P S K	4	2	$B_T^{4\phi} = \frac{1}{2} B_T^b$
8- P S K	8	3	$B_T^{8\phi} = \frac{1}{3} B_T^b$
16- P S K	16	4	$B_T^{16\phi} = \frac{1}{4} B_T^b$
Q A M	16	4	$B_T^{QAM} = \frac{1}{4} B_T^b$

162

154.

MODULACION

VELOCIDAD (bits/s)

F S K

1200

4-P S K

2400

8-P S K

4800

16-P S K

9600

155.
163

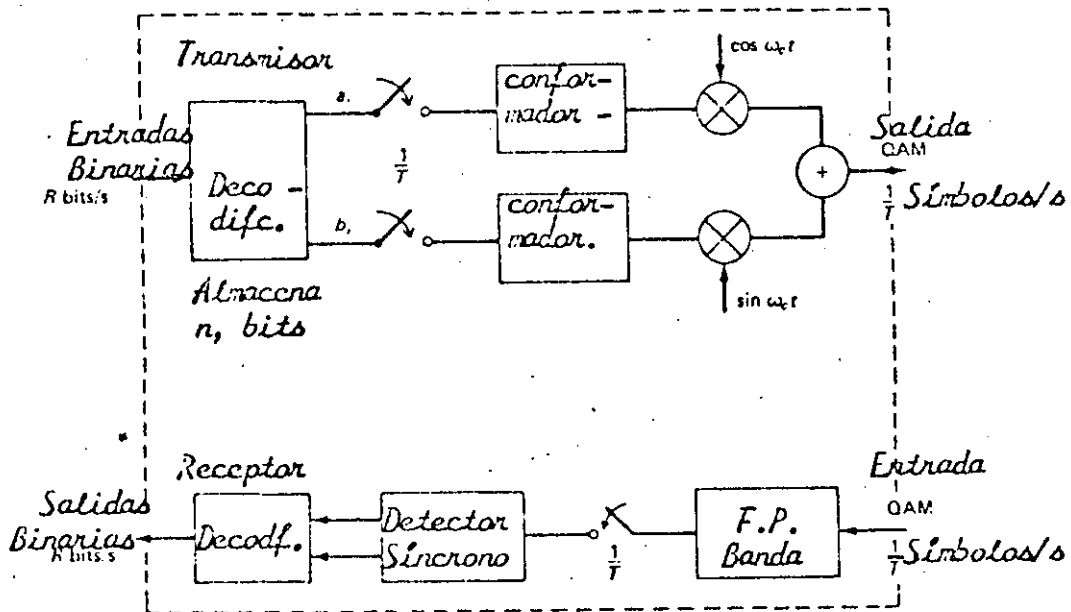


FIGURA N° 34

Diagrama Simplificado de un modem QAM.

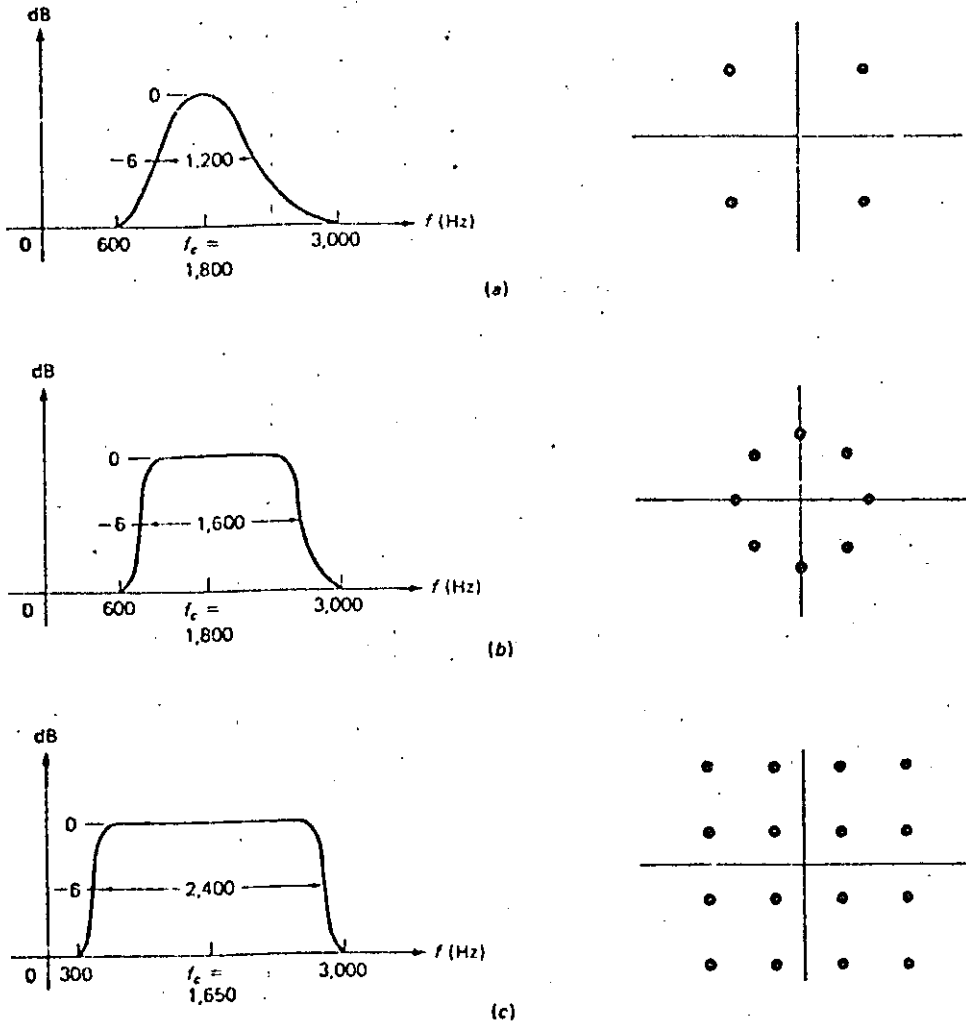


FIGURA N° 35

Espectro y Constelación para módems de Alta Velocidad: a) 2400 bits/s, PSK de 4 fases, característica cosenoidal; b) 4800 bits/s, PSK de 8 fases, 50 % de factor de conformación; c) 9600 bits/s, QAM, 16 estados, 10 % de factor de conformación.

TASA DE ERROR EN TRANSMISION BINARIA

La probabilidad de que una muestra medida $n(t_1)$ caiga en el rango de n a $n + dn$ está dada por $f(n) dn$, con

$$f(n) = \frac{e^{-n^2/2\sigma^2}}{\sqrt{2\pi\sigma^2}}$$

0 \longrightarrow 1

1 \longrightarrow 0

error $P_e \longrightarrow P_{\text{Ruido}} > A/2$

Si un 0 está presente $v(t) = n(t)$

Así la función de densidad para v , asumiendo que un cero está presente, es

$$f_0(v) = \frac{1}{\sqrt{2\pi\sigma^2}} e^{-v^2/2\sigma^2}$$

$$P_{e_0} = \text{Prob}(v > A/2) = \int_{A/2}^{\infty} f_0(v) dv$$

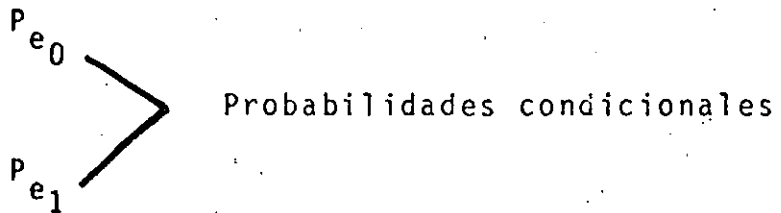
Si un 1 se transmite

$$v(t) = A + n(t)$$

$$f_1(v) = \frac{1}{\sqrt{2\pi\sigma^2}} e^{-(v - A)/2\sigma^2}$$

$$P_{e_1} = \text{Prob}(v < A/2) = \int_{-\infty}^{A/2} f_1(v) dv$$

Probabilidad total del sistema ?



P_0 y P_1 eventos mutuamente exclusivos

$$\longrightarrow (P_0 + P_1)$$

$$P_e = P_0 P_{e_0} + P_1 P_{e_1}$$

$$P_e = \frac{1}{2} \left(1 - \text{erf} \frac{A}{2\sqrt{2}\sigma} \right)$$

donde

$$\text{erf} = \frac{2}{\pi} \int_0^x e^{-y^2} dy$$

bargo, asumir que se conocen las características estadísticas del ruido. En particular se considera que el ruido tiene una función de probabilidad gaussiana, con $E(n) = 0$. Específicamente, si se muestrea el ruido en cualquier tiempo arbitrario t_1 , la probabilidad de que la muestra medida $n(t_1)$ caiga en el rango de n a $n+dn$ esta dada por $f(n) dn$, con

$$f(n) = \frac{e^{-n^2/2\sigma^2}}{\sqrt{2\pi}\sigma^2} \quad (1)$$

Este es el modelo estadístico más usado para ruido aditivo en comunicaciones, y es en la mayoría de aplicaciones, una representación válida para el ruido real presente.

Se considera que la varianza del ruido σ^2 es conocida (puede ser medida). La función se muestra en la fig. 37. En este capítulo, analizaremos la probabilidad de error al tomar un nivel de ruido en lugar de señal y viceversa.

Considere que en un sistema binario la amplitud de los pulsos es A volts. La secuencia compuesta de símbolos binarios más ruido es muestreada una vez cada intervalo binario y se hace una decisión si un 1 ó un 0 esta presente. Una simple forma particular de hacer la decisión es decidir un 1 si el voltaje compuesto es mayor que $A/2$ volts, y 0 si la muestra es menor que $A/2$ volts.

Ocurrirán errores si, con un pulso presente la muestra de

voltaje compuesto es menor que $A/2$, o, con un pulso ausente, si el ruido solo excede a $A/2$.

Un ejemplo de una posible secuencia de señal, indicando los dos posibles tipos de error, es mostrada en la fig. 38.

Para determinar la probabilidad de error cuantitativamente se consideran los dos posibles tipos de error separadamente. Considerese primero que un cero es enviado, tal que ningún pulso esta presente al tipo de decodificar. La probabilidad de error en este caso es justamente la probabilidad de que el ruido exceda la amplitud $A/2$ y sea equivocado por un pulso ó un 1 en el código binario. De la misma forma ya que $v(t) = n(t)$ si un 0 esta presente, el valor muestreado v es una variable aleatoria con la misma característica estadística del ruido. La probabilidad de error es entonces la probabilidad de que v apareciera entre $A/2$ e ∞ . Así la función de densidad para v , asumiendo un cero presente, es justamente

$$f_0(v) = \frac{1}{\sqrt{2\pi}\sigma} e^{-v^2/2\sigma^2} \quad (2)$$

el índice 0 denota la presencia de un 0 y la probabilidad de error P_{e0} en este caso es el area bajo la curva $f_0(v)$ de $A/2$ a ∞ .

$$P_{e0} = \text{Prob} (v > \frac{A}{2}) = \int_{A/2}^{\infty} f_0(v) dv \quad (3)$$

la función de densidad $f_0(v)$ se muestra en la fig. 39, con

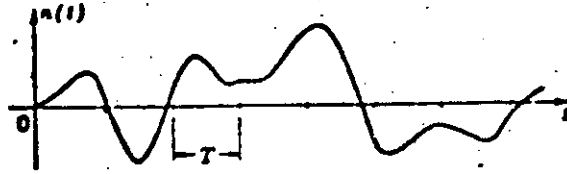


FIGURA N° 36
Típico Oscilograma de Voltaje de Ruido

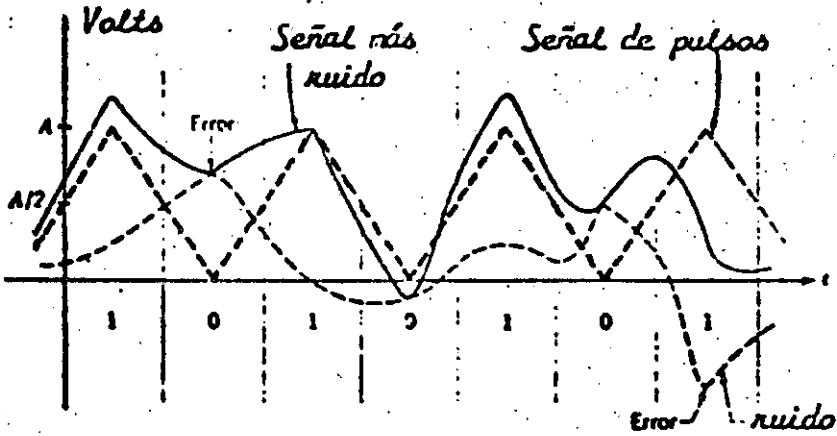


FIGURA N° 38
Efectos del ruido en la Transmisión de Pulsos Binarios

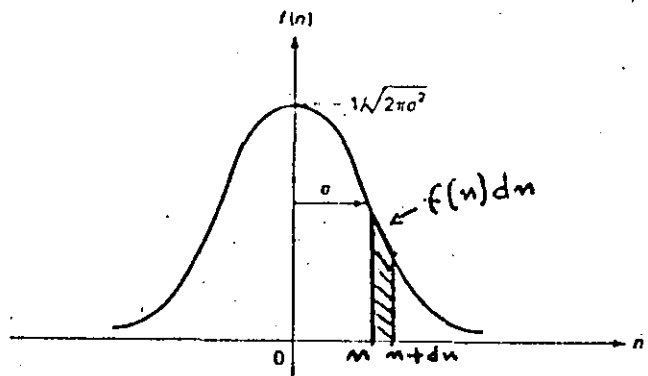


FIGURA N° 37
FUNCION DE DENSIDAD DE PROBABILIDAD
GAUSSIANA.

la probabilidad de error indicada por el area sombreada.

Considerese ahora que un 1 es transmitido. Este aparece en el decodificador como un pulso de amplitud A volts más el ruido superimpuesto. Una muestra $v(t)$ del voltaje compuesto tomado a un tiempo t es ahora una variable aleatoria $A+n(t)$. La cantidad fija A sirve para defasar el nivel del ruido de un promedio de cero volts, a un promedio de A volts. La variable aleatoria v tiene la misma estadística que n , fluctuando respecto a A , y de cualquier modo diferente de cero. Su función de densidad es la misma función gaussiana, con la misma varianza, pero con un valor promedio de A . Así, tenemos

$$f_1(v) = \frac{1}{\sqrt{2\pi}\sigma} e^{-(v-A)^2/2\sigma^2} \quad (4)$$

Esta ecuación se muestra en la fig. 39b:

La probabilidad de error corresponde ahora a la posibilidad de que la muestra v de la señal más el ruido caiga abajo de $A/2$ volts y sea equivocada por ruido solamente (o sea juzgado, incorrectamente, un cero). Este es justamente el area bajo la curva de $f_1(v)$ desde $-\infty$ a $A/2$ y esta dada por

$$P_{e1} = \text{Prob} (v < \frac{A}{2}) = \int_{-\infty}^{A/2} f_1(v) dv \quad (5)$$

Esta probabilidad de error se indica por el área sombreada de la fig. 39b.

Es interesante preguntar como se definiria la probabilidad de error de todo el sistema. Nótese que los dos posibles tipos de error considerados pertenecen a eventos mutuamente exclusivos; el error de un tipo no puede ocurrir al mismo tiempo que el error del otro tipo.

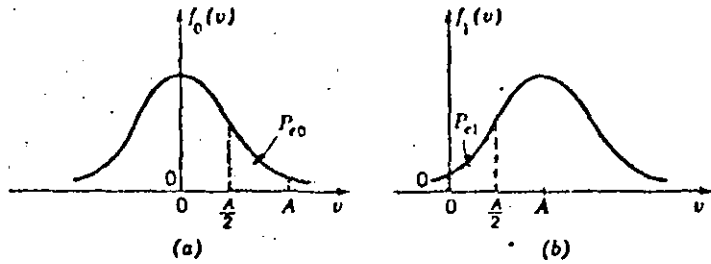


FIGURA N° 39

Densidad de Probabilidad en la Transmisión de Pulsos Binarios: a) Ruido únicamente (se ha transmitido un cero); b) Pulso más ruido (se ha transmitido un uno).

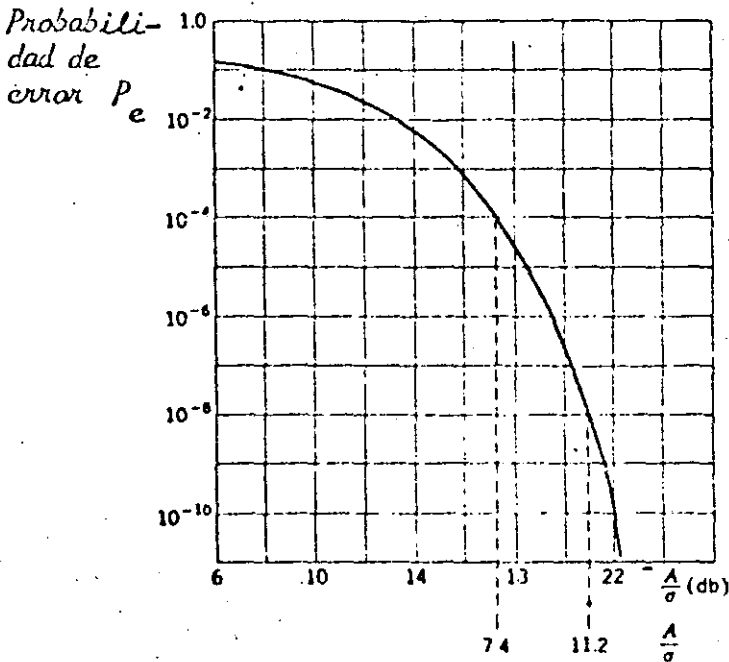


FIGURA N° 40

Probabilidad de Error por Ruido Gaussiano en la Detección Binaria.

Por lo que las probabilidades pueden sumarse.

Sin embargo, en este caso, es evidente que P_{e0} y P_{e1} sean ambas probabilidades condicionales, en la primera se asume que esta presente un cero, es la segunda se considera un 1 presente.

Para remover esta condicionalidad se debe multiplicar cada una por su apropiada probabilidad de ocurrencia a priori.

Así, considerando que la probabilidad de transmitir un cero es P_0 , mientras que la probabilidad de transmitir un 1 es P_1 , ambas conocidas tal que $P_0 + P_1 = 1$, se tiene que la probabilidad de error total es

$$P_e = P_0 P_{e0} + P_1 P_{e1} \quad (6)$$

Es evidente de la fig. 39 y de la simetría de las curvas gaussianas que los dos probabilidades condicionales P_{e0} y P_{e1} son iguales en este ejemplo. Como $P_0 = P_1 = \frac{1}{2}$

$$P_e = \frac{1}{2} \left[1 - \operatorname{erf} \frac{A}{2\sqrt{2} \sigma} \right] \quad (7)$$

donde

$$\operatorname{erf} x = \frac{2}{\sqrt{\pi}} \int_0^x e^{-y^2} dy$$

La función de error $\operatorname{erf} x$ definida en (1) esta tabulada en libros de estadística ó en varias tablas matemáticas. Con

los 1's y 0's considerados con la misma probabilidad de ocurrencia, en un largo mensaje, la ecuación (7) dá la probabilidad de error en la decodificación de cualquier dígito. Note que la probabilidad de error P_e depende únicamente de A/σ , la relación de la amplitud de la señal a la desviación estandard del ruido. Esta cantidad σ es comúnmente referida como el ruido rms. La relación A/σ es entonces la relación señal a ruido rms. La probabilidad de error se muestra graficada contra A/σ en la Fig. 40. Es evidente que $\sigma^2 = N$ (potencia).

Ejemplo

$$\frac{A}{\sigma} = 7.4 (17.4 \text{ dB}); P_e = 10^{-4}$$

↓
1 bit en 10^4 es tomado incorrecto

$$\frac{A}{\sigma} = 11.2 (21 \text{ db}); P_e = 10^{-8}$$

Si transmitimos 10^5 bits/s

se comete un error cada

1000 s ó 15 min.

Diseñadores usan $P_e = 10^{-5}$ ó 10^{-6}

DETECCION DE SEÑALES BINARIAS Y RUIDO.

Si se recibe señal y ruido en el detector síncrono, tendremos que la entrada en el detector está dada por

$$\begin{aligned}
 v(t) &= f(t) \cos \omega_0 t + n(t) \\
 &= [f(t) + x(t)] \cos \omega_0 t - y(t) \sin \omega_0 t
 \end{aligned}
 \tag{8}$$

Para PSK $f(t) = \pm A$, para ASK $f(t)$ es $+A$ ó 0 . En el caso FSK ω_c es ω_1 ó ω_2 y $f(t)$ es A si una señal está presente en uno de los dos canales paralelos y 0 si está ausente.

En general, la salida del detector está dada por

$$V_o(t) = f(t) + x(t) \tag{9}$$

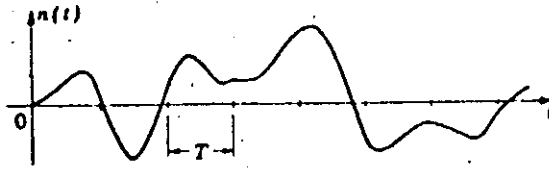


FIGURA N° 36
Típico Oscilograma de Voltaje de Ruido

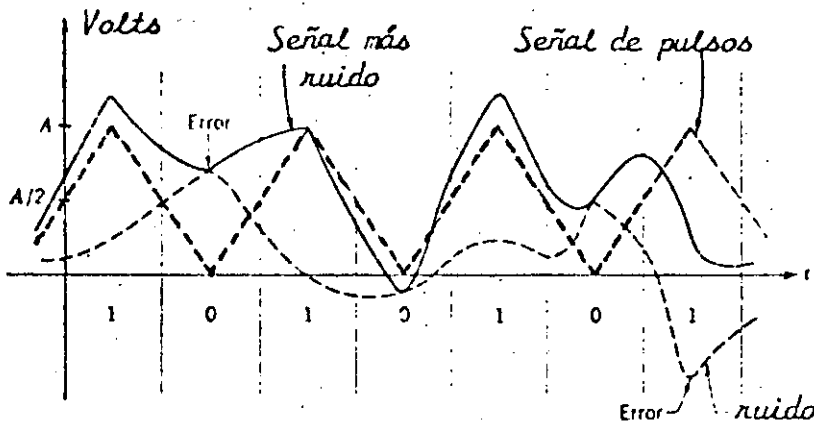


FIGURA N° 38
Efectos del Ruido en la Transmisión de
Pulsos Binarios

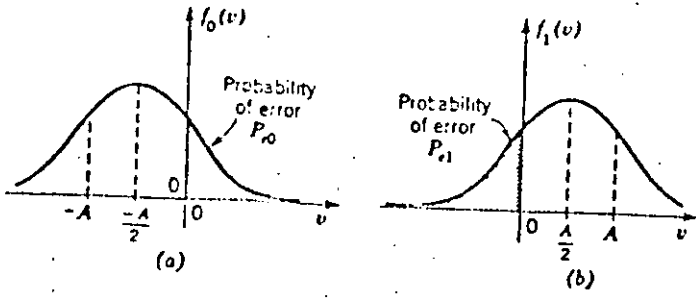
Para señales polares la Fig. 1 muestra las probabilidades de error.

NIVELES DE DECISION OPTIMOS.

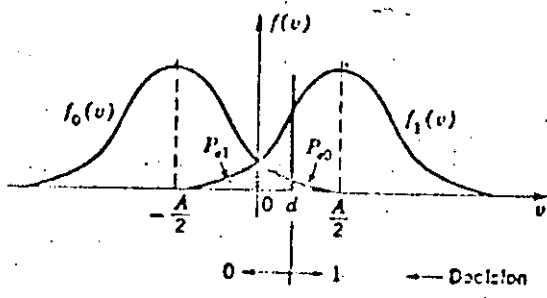
Ya que el decodificador basa su decisión en la amplitud de la señal para poder optimizar $v(t)$, es conveniente variar el nivel de amplitud en el cual la decisión es realizada.

Si 0's ocurren más frecuentemente en el promedio ($P_0 > P_1$), es conveniente desplazar el nivel de decisión (d) negativamente. Desde luego que el óptimo " d " depende de P_0 y P_1 .

Para hacer esta discusión más cuantitativamente debemos regresar a la formulación original de la probabilidad de error.



Probability densities in the transmission of NRZ-polar binary pulses. (a) Negative pulse transmitted. (b) Positive pulse.



Choice of decision level in binary transmission.

$$P_e = P_0 \underbrace{\int_d^{\infty} f_0(v) dv}_{P_{e_0}} + P_1 \underbrace{\int_{-\infty}^d f_1(v) dv}_{P_{e_1}}$$

$$\frac{\partial P_e}{\partial d} = 0 = -P_0 f_0(d) + P_1 f_1(d)$$

$$\frac{f_1(d)}{f_0(d)} = \frac{P_0}{P_1}$$

$$\exp \left[\frac{-(d - \frac{A}{2})^2}{2\sigma^2} + \frac{(d + \frac{A}{2})^2}{2\sigma^2} \right] = \frac{P_0}{P_1}$$

$$d_{opt} = \frac{\sigma^2}{A} \ln \frac{P_0}{P_1}$$

Para ASK

$$v_o / \text{ASK} (t) = \begin{matrix} A \\ 0 \\ 0 \end{matrix} + x(t)$$

ya que la salida es idéntica

$$P_{e, \text{ASK}} = \frac{1}{2} \left[1 - \operatorname{erf} \frac{A}{2\sqrt{2} N} \right] = \frac{1}{2} \operatorname{erfc} \frac{A}{2\sqrt{2} N} \quad (10)$$

Para PSK la salida del detector síncrono consiste de una señal polar $\pm A$ más ruido. Esto corresponde exactamente a la señal polar analizada anteriormente. Sin embargo, aquí se tiene que la señal es $\pm A$, en lugar de $\pm \frac{A}{2}$. Entonces la probabilidad de error es

$$P_{e, \text{PSK}} = \frac{1}{2} \operatorname{erfc} \frac{A}{\sqrt{2} N} \quad (11)$$

como se puede comparar (11) con (10) el sistema PSK requiere solamente la mitad de la amplitud de la señal que el sistema ASK.

En el caso del sistema FSK las salidas de los dos detectores son comparadas. En cualquier instante un detector tiene señal más ruido, el otro solo tiene ruido. Llamando la salida de ruido de un canal x_1 , y la del otro x_2 , se tiene al restar las salidas de los dos canales, la salida FSK dada por

$$v_o, \text{FSK} = \begin{matrix} +A \\ 0 \\ -A \end{matrix} + (x_1 - x_2)$$

La señal de salida es otra vez polar: $+A$ aparece si un 1 ha sido transmitido y $-A$ para un cero, la salida de ruido total es sin embargo $x_1 - x_2$. Si los ruidos en los dos canales son independientes, las varianzas se suman. Se ha, afectivamente, doblado el ruido al sustraer las dos salidas. Sin embargo, ya que la señal de salida es polar, la desviación de la señal efectiva, como en el caso PSK, es dos veces la de ASK. Así, para FSK

$$P_e \text{ FSK} = \frac{1}{2} \operatorname{erfc} \frac{A}{2\sqrt{N}} \quad (13)$$

Para una probabilidad de error específico, el sistema FSK requiere 3 dB más de potencia en la señal que el sistema PSK con la misma potencia de ruido, pero es 3 dB mejor que el sistema ASK.

La relación señal a ruido de salida de un filtro óptimo es: $\frac{A^2}{N} = \frac{2E}{n_0}$ para el caso de la detección de un pulso en ruido.

E representa la energía de la señal en el punto donde el ruido blanco gaussiano de densidad espectral $\frac{n_0}{2}$ es agregado.

La fig. 41 ilustra la probabilidad de error para sistemas FSK y PSK en función de la relación señal a ruido $\frac{A^2}{2N}$.

En la práctica de microondas se utilizan los sistemas M-PSK, QAM, los cuales serán analizados a continuación en cuanto se refiere a la probabilidad de error.

DETECCION NO COHERENTE

Si la coherencia de fase no se puede mantener, ó si es antieconómico incorporar circuitos de control de fase en el receptor, entonces se usa detección de envolvente.

Es evidente que las señales PSK requieren coherencia de fase para ser demoduladas, de ahí que sólo las señales OOK y FSK utilizan detectores de envolvente.

OOK

$$v(t) = [f(t) + x(t)] \cos \omega t - y(t) \sin \omega t$$

Aquí. $f(t) = A \text{ ó } 0$

$$v(t) = r(t) \cos [\omega t + \theta(t)]$$

$$r = \sqrt{(f + x)^2 + y^2}$$

$$\theta = \tan^{-1} \frac{y}{f+x}$$

La probabilidad de error depende de la estadística de r en los dos casos: $f = A \text{ ó } 0$.

ESTADÍSTICAS DE RAYLEIGH Y DE RICIÁN

Considérese primero el caso donde la señal está ausente, es decir sólo se tiene ruido, $A = 0$. Con x y y independientes y Gaussianas, el problema es determinar la estadística de la envolvente aleatoria r . Hacemos esto primero encontrando la estadística conjuntamente de r y θ y entonces integramos sobre θ para encontrar la función de densidad de r .

$$x = r \cos \theta$$

$$y = r \sin \theta$$

$$f_{xy}(x,y) dx dy = f_{r\theta}(r,\theta) dr d\theta$$

$$f_{xy}(x,y) = f_x(x) f_y(y) = \frac{e^{-(x^2+y^2)/2\sigma^2}}{2\pi\sigma^2} = \frac{e^{-r^2/2\sigma^2}}{2\pi\sigma^2}$$

$$dx dy = r dr d\theta$$

$$f_{r\theta}(r,\theta) dr d\theta = \frac{r e^{-r^2/2\sigma^2}}{2\pi\sigma^2} dr d\theta$$

$$f_{r\theta}(r,\theta) = \frac{r e^{-r^2/2\sigma^2}}{2\pi\sigma^2}$$

$$f_r(r) = \int_0^{2\pi} f_{r\theta}(r,\theta) d\theta$$

$$= \frac{r e^{-r^2/2\sigma^2}}{\sigma^2}$$

$$f = A$$

$$v(t) = [A + x(t)] \cos \omega_0 t + y(t) \sin \omega_0 t$$

$$x' = x + A$$

$$f(x') = \frac{e^{-(x' - A)^2 / 2 \sigma^2}}{2 \pi \sigma^2}$$

La envolvente $v(t)$ está dada por

$$r^2 = x'^2 + y^2 = (x + A)^2 + y^2$$

$$\theta = \tan^{-1} \frac{y}{x'} = \tan^{-1} \frac{y}{x+A}$$

con x' y y variables independientes

$$x' = r \cos \theta$$

$$y = r \sin \theta$$

$$f(r, \theta) dr d\theta = f(x', y) dx' dy$$

$$= \frac{e^{-[(x' - A)^2 + y^2] / 2 \sigma^2}}{2 \pi \sigma^2} dx' dy$$

$$= \frac{e^{-A^2/2\sigma^2} r e^{-(r^2 - 2rA \cos \theta)/2\sigma^2}}{2\pi\sigma^2} dr d\theta$$

siendo r y θ variables independientes

$$f(r) = \frac{e^{-A^2/2\sigma^2} r e^{-r^2/2\sigma^2}}{2\pi\sigma^2} \int_0^{2\pi} e^{rA \cos \theta / \sigma^2} d\theta$$

pero

$$I_0(z) = \frac{1}{2\pi} \int_0^{2\pi} e^{z \cos \theta} d\theta$$

Así que

$$f(r) = \frac{r e^{-r^2/2\sigma^2}}{N} e^{-A^2/2N} I_0\left(\frac{rA}{N}\right)$$

CALCULO DE PROBABILIDAD DE ERROR

$$P_e = P_0 \int_b^{\infty} f_n(r) dr + P_1 \int_0^b f_s(r) dr$$

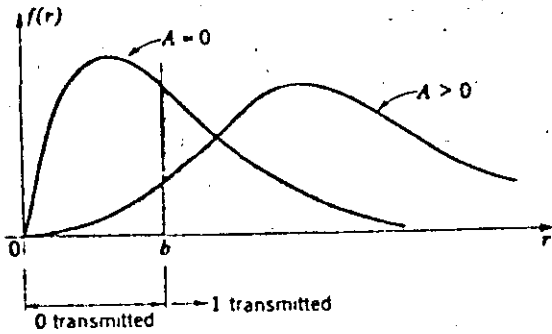
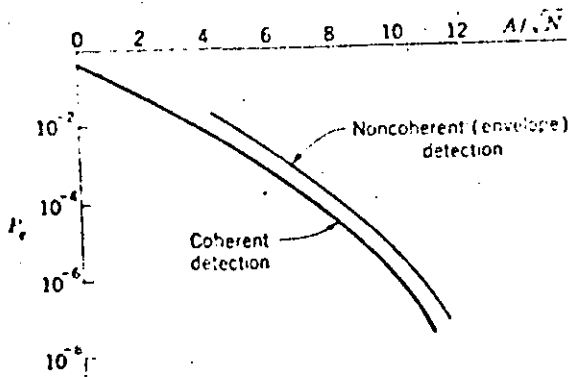


Figure 5-46 Decision regions with envelope-detected OOK signals.



Binary error probabilities, OOK transmission.

FSK

$$P_e = \int_{r_1=0}^{\infty} f_s(r_1) \left[\int_{r_2=r_1}^{\infty} f_n(r_2) dr_2 \right] dr_1$$

$$P_e = \int_0^{\infty} \frac{r_1}{N} e^{-r_1^2/N} e^{-A^2/2N} I_0\left(\frac{r_1 A}{N}\right) dr_1$$

$$P_e = \frac{1}{2} e^{-A^2/4N}$$

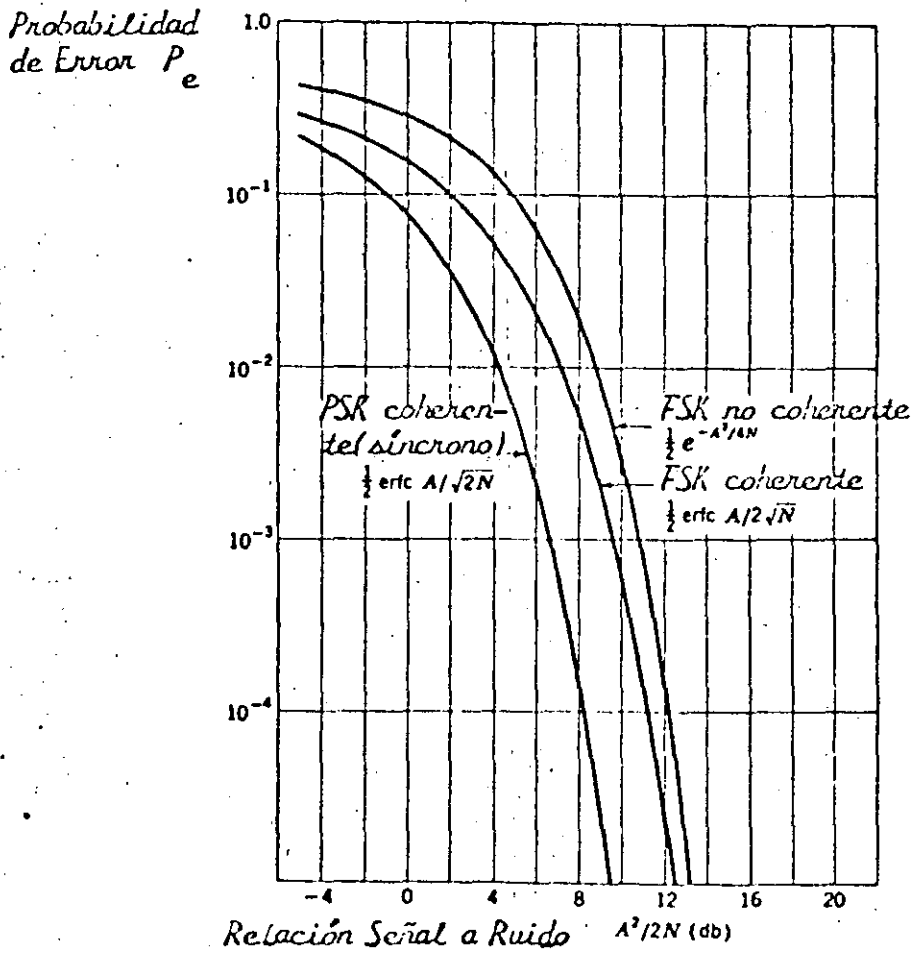


FIGURA N° 41
Transmisión Binaria.

COMPARACION DE DIFERENTES ESQUEMAS DE MODULACION DIGITAL

ESQUEMA	ANCHO DE BANDA	P_e	$\frac{S}{N}$ PARA $P_c=10^{-4}$	COMPLEJIDAD DE EQUIPO
ASK Coherente	2B	$\frac{1}{2} \operatorname{erfc} \frac{A}{2\sqrt{2}N}$	14.45	Moderado
ASK Incoherente	2B	$\frac{1}{2} \exp\left(-\frac{A^2 T_b}{16n_0}\right)$	18.33	Menor
FSK Coherente	>2B	$\frac{1}{2} \operatorname{erfc} \frac{A}{2\sqrt{N}}$	10.6	Mayor
FSK Incoherente	>2B	$\frac{1}{2} \exp\left(\frac{-A^2}{4N}\right)$	15.33	Menor
PSK Coherente	2B	$\frac{1}{2} \operatorname{erfc} \frac{A}{\sqrt{2}N}$	8.45	Mayor
DPSK	2B	$\frac{1}{2} \exp\left(\frac{-A^2 T_b}{2n_0}\right)$	9.30	Moderado

184.
193

La siguiente obtención de la probabilidad de error es ilustrada sobre un diagrama espacial en un sistema QPSK pero que también se aplica al caso binario, y en general, a sistemas $M=ary$, donde $M = 2, 9, 6, 8, 16, \dots$, esto es, $M = 2^n$. En el diagrama espacial de la fig. 42 cada estado de fase de igual amplitud representa un símbolo; cada símbolo contiene $n=2$ bits de información. Considerese que el vector $\psi = 0^\circ$ a sido codificado en el transmisor para representar el estado lógico 00, mientras que los vectores de $90^\circ, 180^\circ,$ y 270° representan los estados lógicos 01, 11, y 10, respectivamente. Consideraremos que cada vector transmitido tiene la misma probabilidad de error; esto es, los datos de entrada en el modulador han sido mezclados y tienen una distribución equiprobable de los estados binarios aleatorios cero y uno.

El diagrama espacial de la señal ilustra que el modem $M=ary$ tiene una simetría circular. Por esta simetría, se puede asumir que en un medio ambiente libre de ruido el vector $\psi = 0^\circ$ que representa el estado 00 ha sido transmitido.

Es también considerado que un modelo de canal de Nyquist es ta disponible. Esto es, en el instante del muestreo no hay interferencia entre símbolos. El teóricamente demodulador de fase óptima detectará el estado de fase 00 correctamente si la portadora recibida más el vector de ruido, en el instante de muestreo, esta dentro de la región $-\pi/M$ y π/M . Como un ejemplo ver el vector $v(t) = \bar{V}_{00}$. Si el vector esta dentro la región π/M y π (región de error E_1) ó den

tro de la región Π y $-\Pi/M$ (región de error E_2), entonces el vector transmitido que tenga una fase $\phi = 0^\circ$ será erroneamente detectado. En el ejemplo de un vector recibido mostrado en la posición $r(t) = \bar{V}_{01}$, el demodulador decidirá que un vector $.01$ ha sido transmitido (en lugar de un 00), y así el fasor detectado será un error.

La portadora recibida y la onda de ruido, $v(t)$, de la señal M-ary PSK esta dada por

$$r(t) = A \cos(\omega_c t + \phi) + n_c(t) \cos(\omega_c t + \phi) + n_s(t) \sin(\omega_c t + \phi) \tag{14}$$

donde A es el valor pico de la portadora recibida, y $n_c(t)$ y $n_s(t)$ representan las componentes de ruido gaussiano instantaneas en fase y en cuadratura de fase. Sin pérdidas, puede asumirse que $\phi = 0$.

En la fig. 43 se representa el diagrama vectorial de la portadora y del ruido. Por las figuras (41) y (42) se concluye que un error ocurrirá si

$$|\alpha| > \frac{\pi}{M} \tag{15}$$

para derivar la probabilidad de error se tiene que definir, primero, la densidad de probabilidad de α . La función de distribución de probabilidad de α dentro de las regiones

$$r(t) = A \cos(\omega_c t + \theta) + n_c(t) \cos(\omega_c t + \theta) \\ + R_s(t) \sin(\omega_c t + \theta)$$

Se tiene error si

$$|\alpha| > \pi/M$$

$$\alpha = \tan^{-1} \frac{m_s(t)}{A + n_c(t)}$$

Para M - ary PSK

$$P(e) = \int_{\pi/M}^{\pi} P(\alpha) d\alpha + \int_{-\pi}^{-\pi/M} P(\alpha) d\alpha \\ = 2 \int_{\pi/M}^{\pi} P(\alpha) d\alpha$$

$$P(\alpha) = \frac{1}{2\pi} e^{-C/N} \left\{ 1 + \sqrt{4\pi \left(\frac{C}{N}\right) \cos \alpha} e^{\frac{C}{N} \cos^2 \alpha} Q\left(\sqrt{2\left(\frac{C}{N}\right) \cos \alpha}\right) \right\}$$

donde

$$Q(x) = \frac{1}{\sqrt{2\pi}} \int_x^{\infty} e^{-t^2/2} dt$$

$$p(e) \cong e^{-C/N} \text{Sen}^2 \frac{\pi}{M}$$

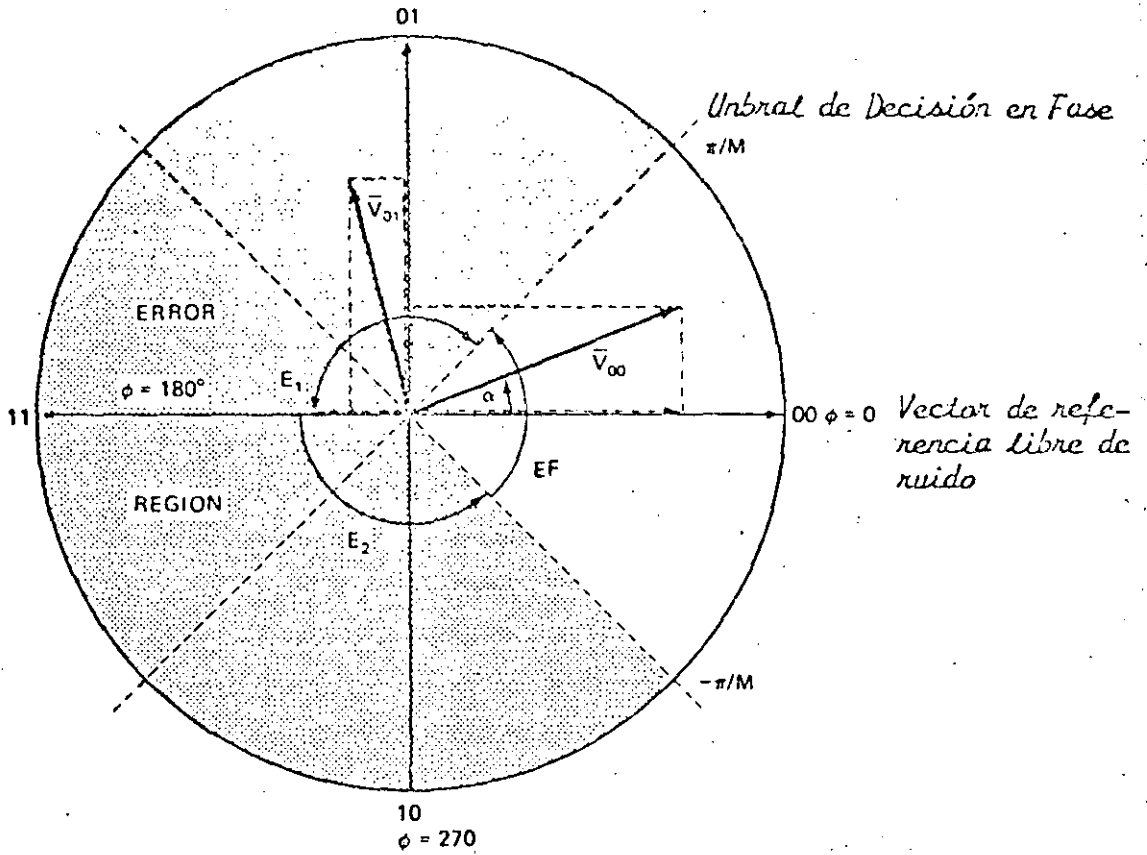


FIGURA N° 42
 Región de Error en Demoduladores Coherentes. iii 4ary. PSK.

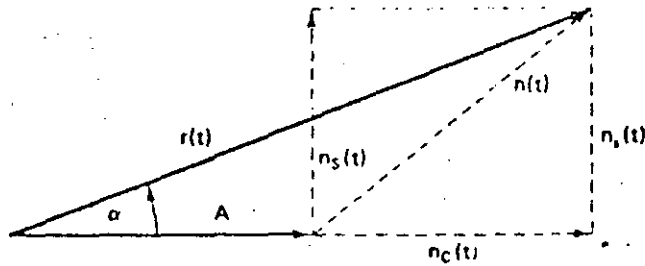


FIGURA N° 43
 Diagrama Vectorial de una Portadora Recibida y de una Señal de Ruido.

de error previamente establecidas E_1 , Π/M a Π y la región E_2 , Π a $-\Pi/M$ esta representada por el área sombreada de la fig. 41 y es la probabilidad de error P_e del sistema. α esta dada por

$$\alpha = \tan^{-1} \frac{n_s(t)}{A + n_c(t)} \quad (16)$$

La P_e del sistema M-ary PSK es

$$P_e = \int_{\Pi/M}^{\Pi} P(\alpha) d\alpha + \int_{-\Pi}^{-\Pi/M} P(\alpha) d\alpha = 2 \int_{\Pi/M}^{\Pi} P(\alpha) d\alpha \quad (17)$$

donde $P(\alpha)$ es la función de densidad de probabilidad de α . Esta función para un canal de ruido blanco gaussiano aditivo ha sido obtenida en referencias y esta dada por

$$P(\alpha) = \frac{1}{2\Pi} e^{-e/n} \left[1 + \sqrt{4\Pi \left(\frac{C}{n} \right)} \cos \alpha e^{(C/N) \cos^2 \alpha} Q \left[\sqrt{2 \left| \frac{C}{n} \right|} \cos \alpha \right] \right] \quad (18)$$

donde

$$Q(x) = \frac{1}{\sqrt{2\Pi}} \int_x^{\infty} e^{-t^2/2} dt \quad (19)$$

En la ecuación (18) el término C/N representa la relación de la potencia media de la portadora especificada en el ancho de banda bilateral de Nyquist el cual es igual al ancho de banda de tasa del símbolo. Como no existe ninguna ecuación de forma cerrada que satisfaga las ecuaciones (18) y

(19), es necesario usar métodos numéricos para evaluar la función $P(e)$. La $P(e)$ puede también ser evaluada por la ecuación simple

$$P(e) \approx e^{-C/N \operatorname{sen}^2 \pi/M} \quad (20)$$

Esta aproximación para relaciones C/N altas ($C/N > 15$ dB) tiene una precisión de 1 dB. Los valores calculados de la curva $P(e) = f(C/N)$, basados en las ecuaciones (17), (18) y (19) han sido gráficos en la fig. 44.

En la mayoría de los sistemas prácticos el ancho de banda de ruido del receptor es mayor que el ancho de banda bilateral de Nyquist. Para proveer una comparación del sistema de ancho de banda mínimo teórico con el sistema práctico de más banda, la ecuación siguiente es frecuentemente usada:

$$\frac{E_b}{N_o} = \left(\frac{C}{N} \right)_{bw} \frac{BW}{f_b} \quad (21)$$

En esta ecuación

E_b = energía promedio de un bit = CT_b

f_b = tasa de bit transmitida

T_b = duración de bit unitario

C = Potencia promedio de la portadora

N_o = Densidad espectral de potencia del ruido, esto es, potencia de ruido promedio en un ancho de banda de

1 Hz.

BW = ancho de banda de ruido del receptor.

La probabilidad de error en los sistemas de microondas terres
tres esta especificada frecuentemente en términos de la relaa
ción C/N, mientras que en sistemas de satelites es especii
ficada en términos de E_b/N_o .

$$P_e = 10^{-6}$$

PSK	Detección coherente	PSK	10.5 dB
		4-PSK	10.5 dB
		8-PSK	13.8 dB
PSK	Detección coherente diferencial	DPSK	11.4 dB
		4-DPSK	12.8 dB
		8-DPSK	16.8 dB
FSK	Detección con discriminador	FSK	13.4
		Duobinaria	15.9
		4-FSK	20.1
		8-FSK	25.5

TABLA I

TABLA I

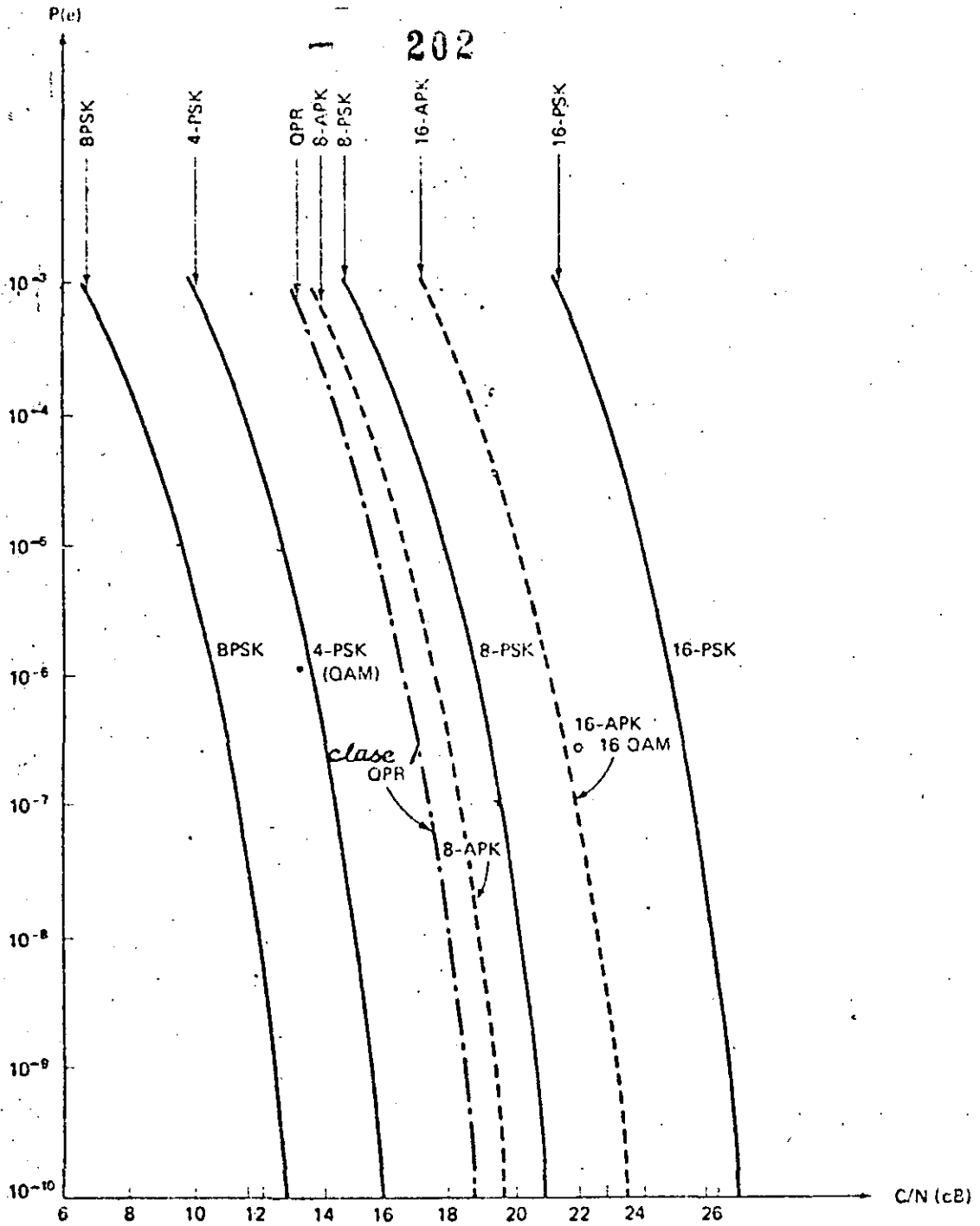


FIGURA N° 44

Representación de la Probabilidad de Error $P(e)$ de Sistemas Coherentes; Binary PSK, QPR y Binary APK. La C/N rms es especificada en el ancho de banda de Nyquist de doble banda lateral.

2.7 TECNICAS DE ACCESO MULTIPLE POR SATELITE
.....

Existen varias formas para que las estaciones terrenas que se comunican entre sí a través de un satélite determinado puedan utilizar los recursos de potencia y ancho de banda del mismo. A estas formas de utilización se les denomina modos o técnicas de acceso múltiple, dado que son múltiples o varias las estaciones que comparten el mismo satélite. Las técnicas de acceso más comunes, son las siguientes:

- Acceso múltiple por división en frecuencia o FDMA *
- Acceso múltiple por división en tiempo o TDMA **
- Acceso múltiple por expansión de espectro o SSMA +
- Acceso múltiple por desplazamiento de haz o SBMA ++

* FDMA = Frequency Division Multiple Access

** TDMA = Time División Multiple Access

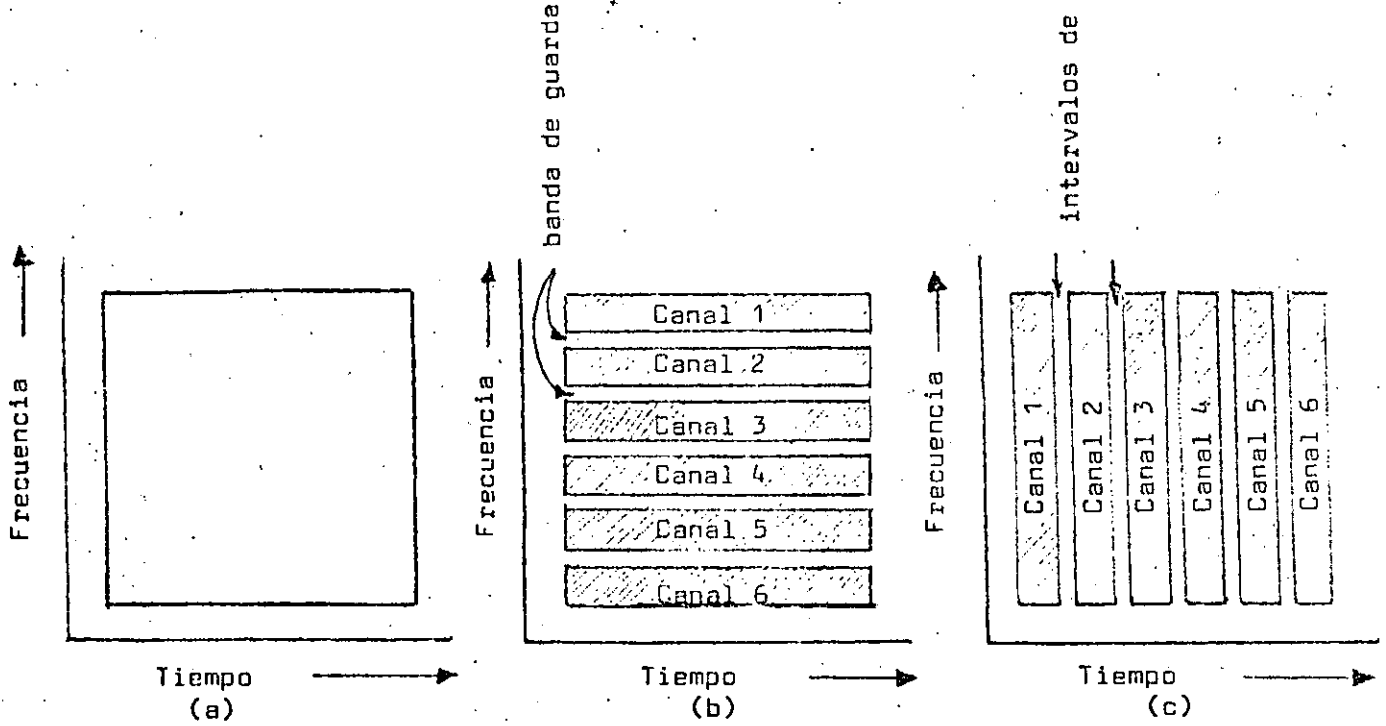
+ SSMA = Spread Spectrum Multiple Access

++ SBMA = Spatial Beam Multiple Access

FDMA es la técnica de mayor uso en la actualidad. Se emplea para transmitir varios grupos de canales de voz multiplexados en frecuencia (FDM) y modulados en frecuencia (FM). Al conjunto de este esquema de transmisión se le denota como FDM/FM/FDMA, indicando la secuencia en el proceso por el que va pasando la señal.

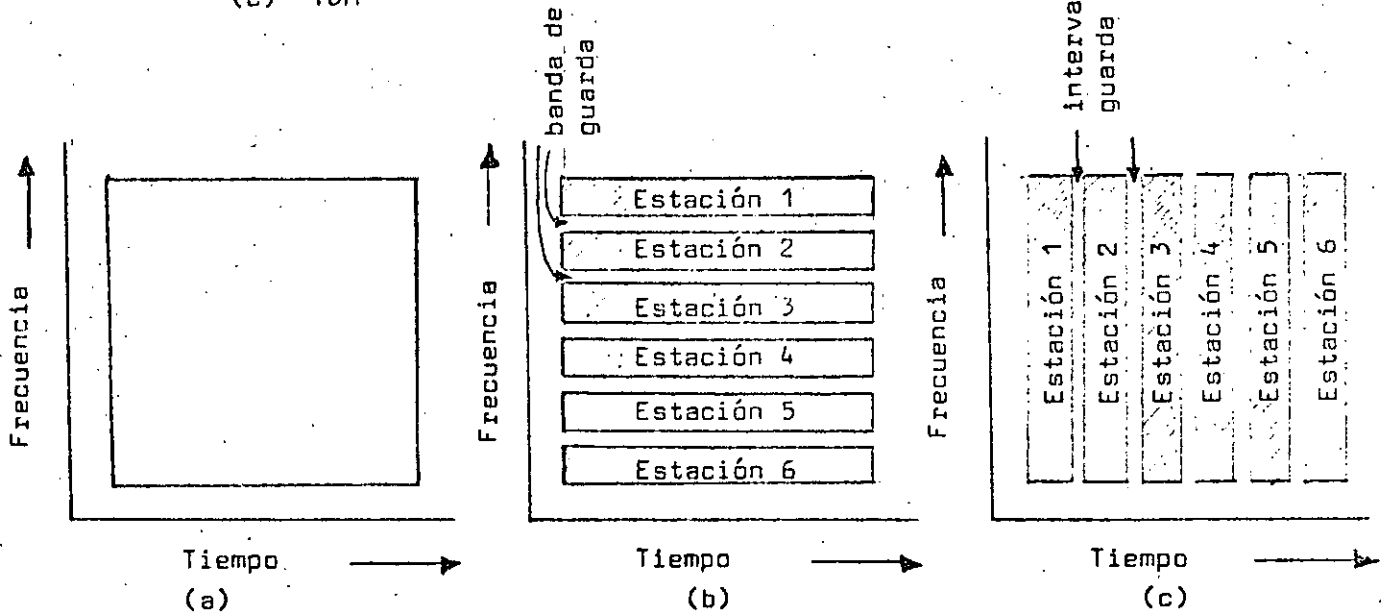
FDMA y TDMA son analogías de los esquemas de multiplexaje que se utilizan en sistemas terrestres multicanal, analógicos y digitales, respectivamente. En estas analogías, los elementos que se "multiplexan" en los enlaces vía satélite son las estaciones terrenas participantes en la red.

(Ver figura 1).



Multiplexaje en sistemas terrestres

- (a) espacio disponible para comunicaciones
- (b) FDM
- (c) TDM



Acceso múltiple en enlaces vía satélite

- (a) espacio disponible para comunicaciones
- (b) FDMA
- (c) TDMA

El acceso múltiple por expansión de espectro o SSMA, únicamente ha encontrado aplicaciones en sistemas satelitales militares donde es inherente la importancia de la privacidad y seguridad. El concepto básico de esta técnica se ilustra en la figura 2.

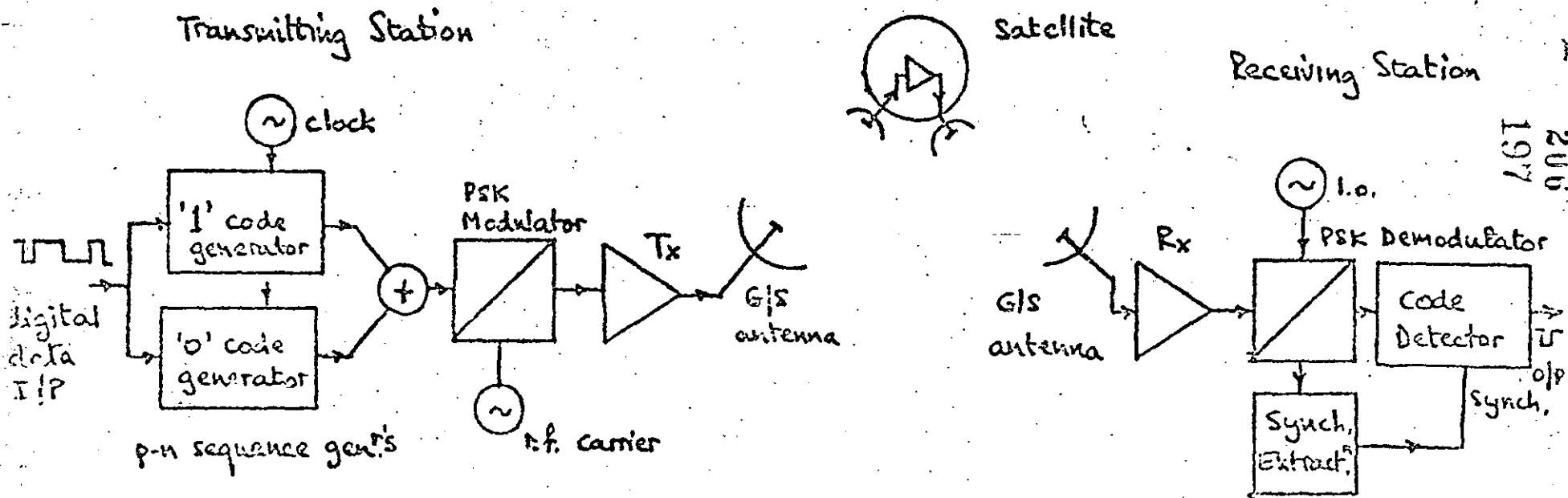
El acceso múltiple por desplazamiento de haz o división de espacio, comienza a ser popular en satélites de alta capacidad como una forma de re-aprovechar las frecuencias disponibles, dirigiendo haces angostos hacia zonas terrestres específicas (véase la figura 3).

Una desventaja de esta técnica, es que el satélite necesita disponer de una antena muy grande para poder producir haces dirigidos angostos. Por ejemplo, la antena del satélite ATS-6 de la NASA, que puede utilizar esta técnica, mide 10 metros de diámetro y los haces "angostos" cubren varios cientos de kilómetros sobre la tierra. Además, el equipo de conmutación o --switching de los haces representa un grave riesgo de falla irremparable en el satélite.

En las figuras 4, 5, 6 y 7 pueden verse, respectivamente, el satélite ATS-6, la distribución de alimentadores, los haces producidos por el arreglo norte-sur de alimentadores y algunas de las huellas de iluminación.

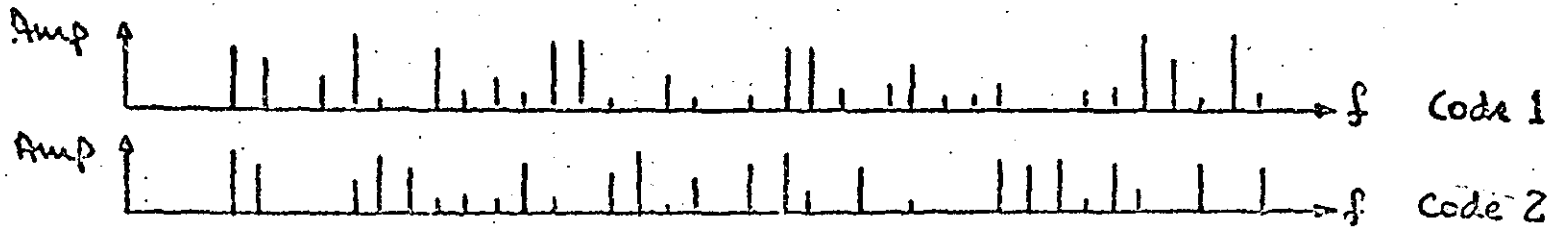
La técnica utilizada universalmente por los satélites comerciales es FDMA y recientemente, aunque en menor escala, --TDMA.

Fig. 2
Acceso múltiple
por expansión de
espectro.



206
197

P-N Sequence scheme for SSMA



Part of spectra of two p-n codes

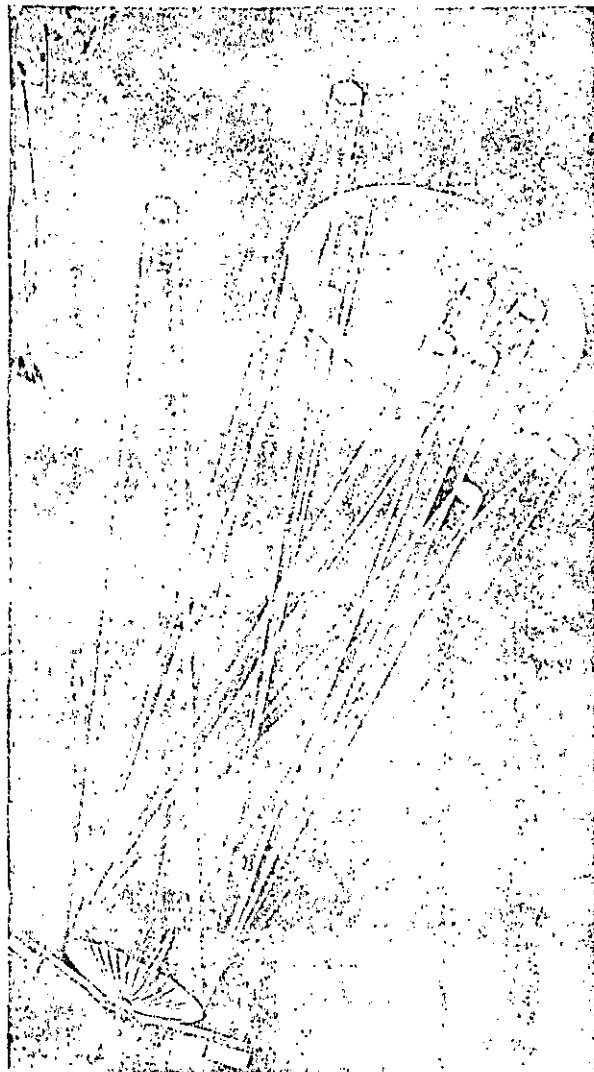


Fig. 3

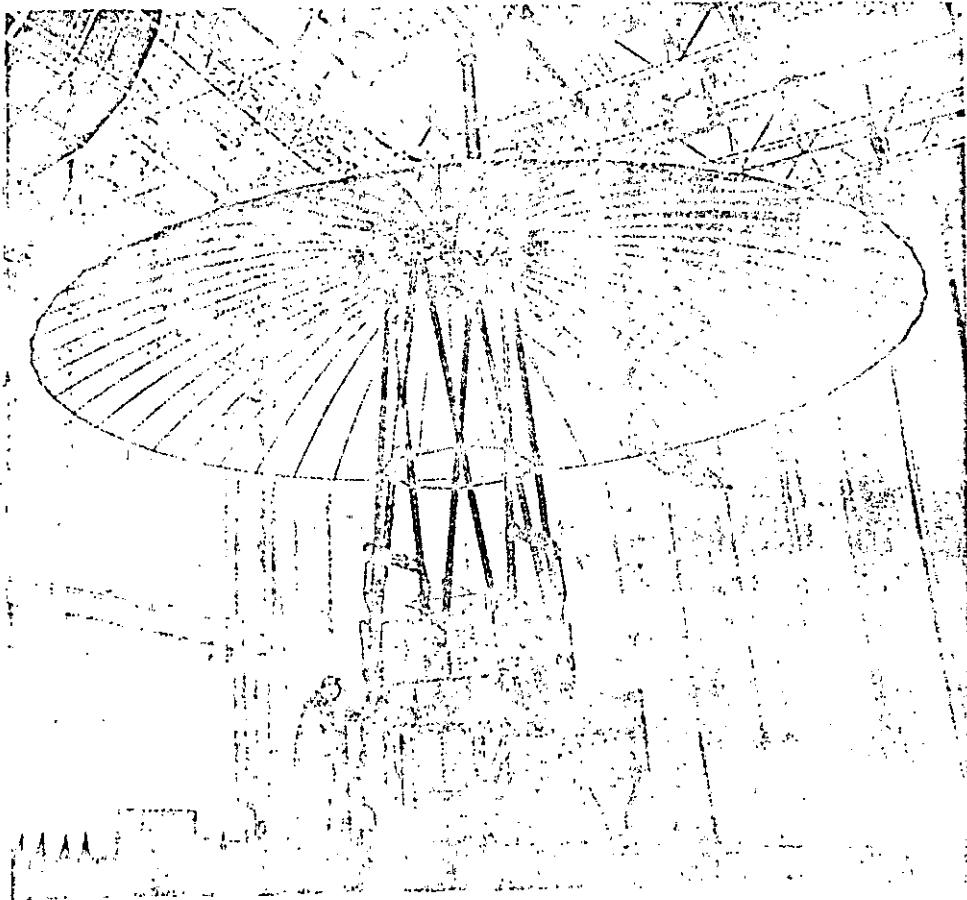


Fig. 4

Antena de 10 metros del satélite ATS-6 de la NASA.

209
200

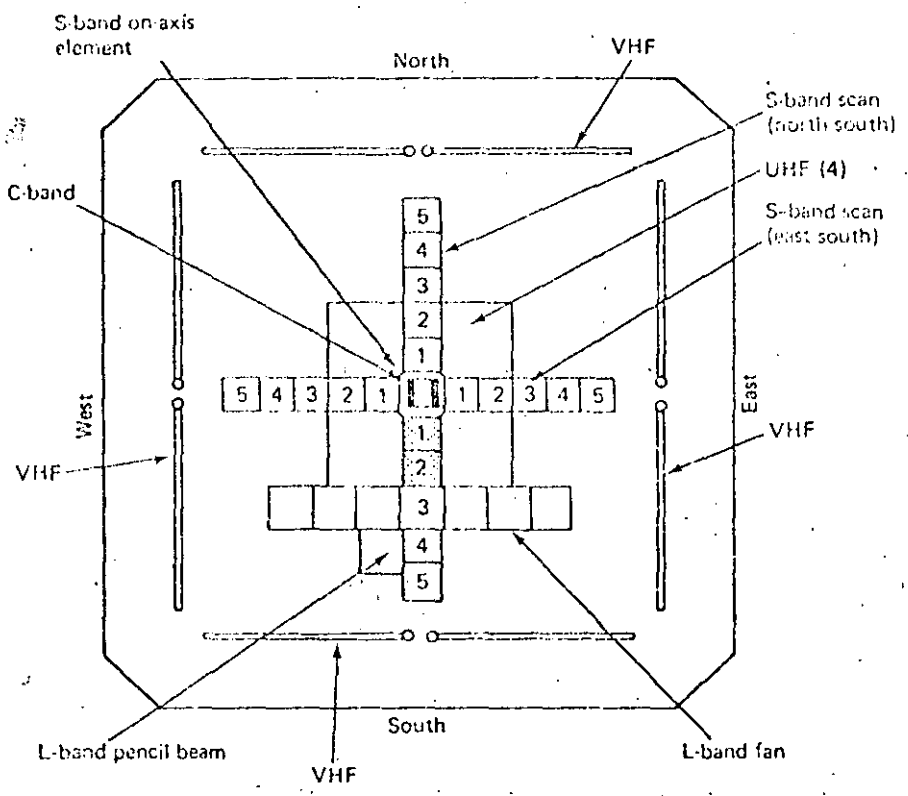


Fig. 5

201

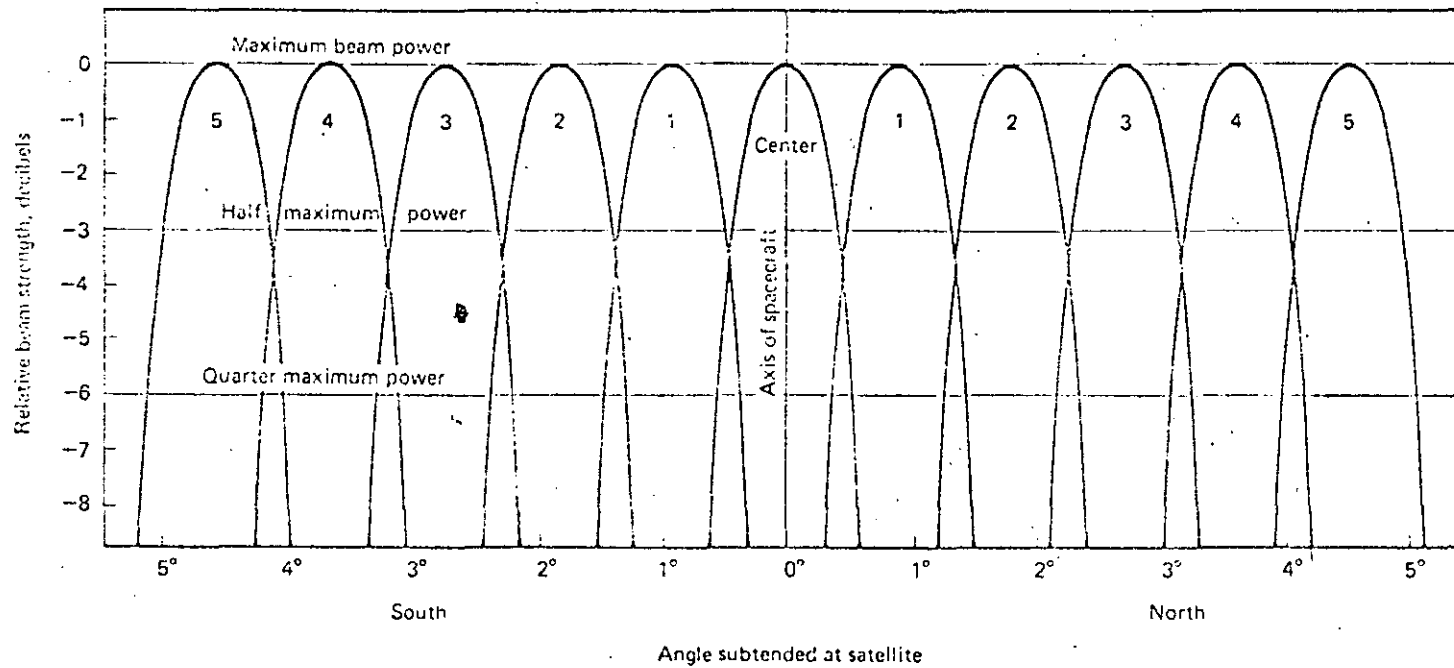


Fig. 6

201

210

211

202

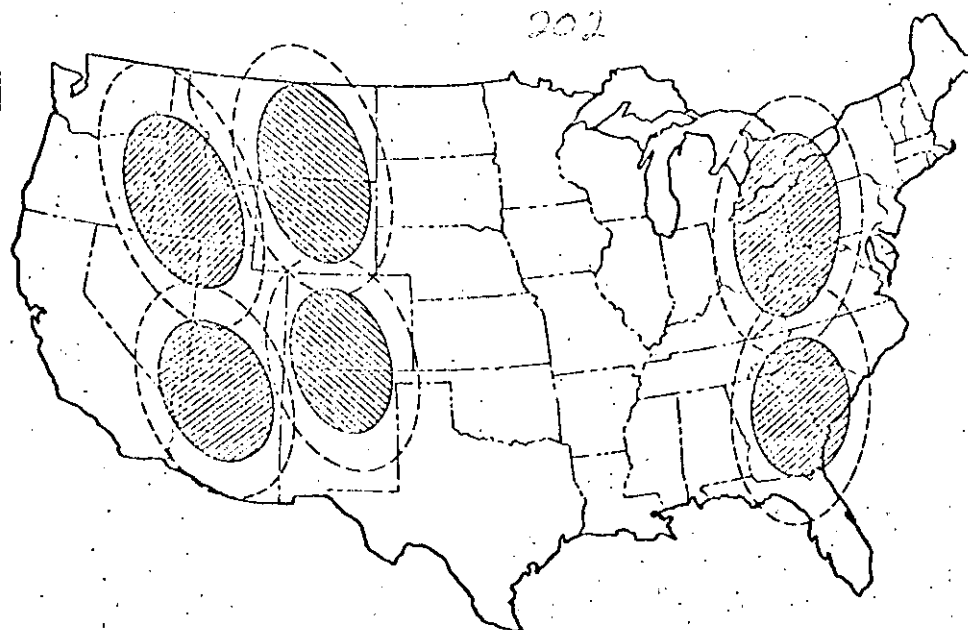


Fig. 7

Acceso múltiple por división en frecuencia (FDMA):

203

- FDM / FM
- SCPC / FM o PSK
 - asignación fija
 - asignación por demanda (DAMA)

En el acceso múltiple por división en frecuencia, la capacidad de ancho de banda de un transpondedor se puede dividir en un número variable de bandas:

- (a) se pueden tener pocas bandas de gran capacidad. Cada banda puede manejar un grupo, un supergrupo, o un mastergrupo de voz (FDM)
- (b) se pueden tener muchas bandas de poca capacidad. Cada banda puede manejar solamente un canal de voz (SCPC)
- (c) se puede tener una mezcla de las dos, FDM y SCPC, con señales de voz.
- (d) se pueden asignar algunas bandas para transmisión de datos, otras para voz y quizás una para TV. Usualmente, un canal de TV ocupa todo el transpondedor de 36 MHz, pero en algunos casos se transmiten dos canales de TV en el mismo transpondedor (se tienen 2 bandas o ranuras), o bien un canal de TV y otros tipos de señales como voz y datos.

La figura 8 ejemplifica el uso de un transpondedor por varias estaciones terrenas a través de FDMA.

En la figura 9 se ilustra el ancho de banda de los transpondedores de los satélites Intelsat IV e Intelsat V. Cada transpondedor puede subdividirse en varias ranuras de frecuencia para su utilización en FDMA, como se ejemplificó en la figura 8.

~~214~~

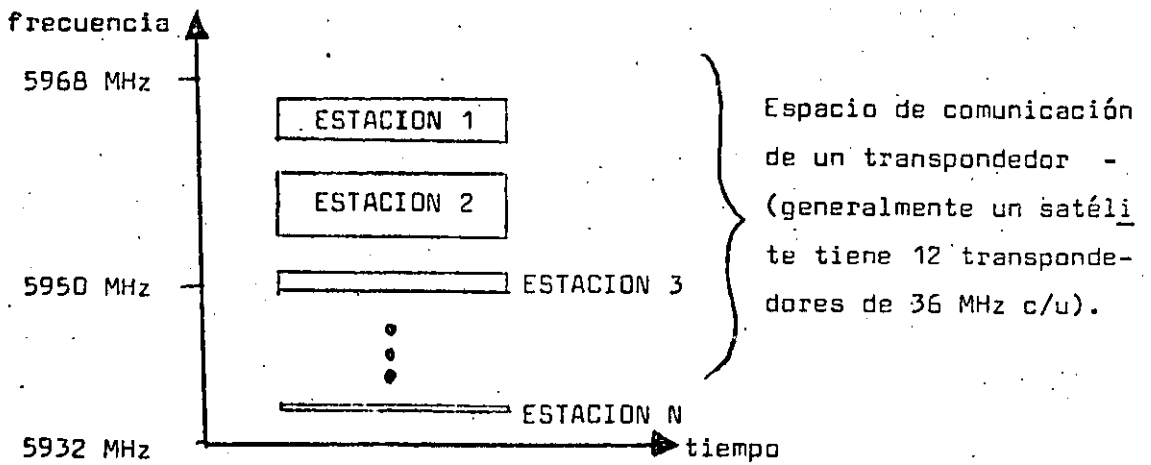
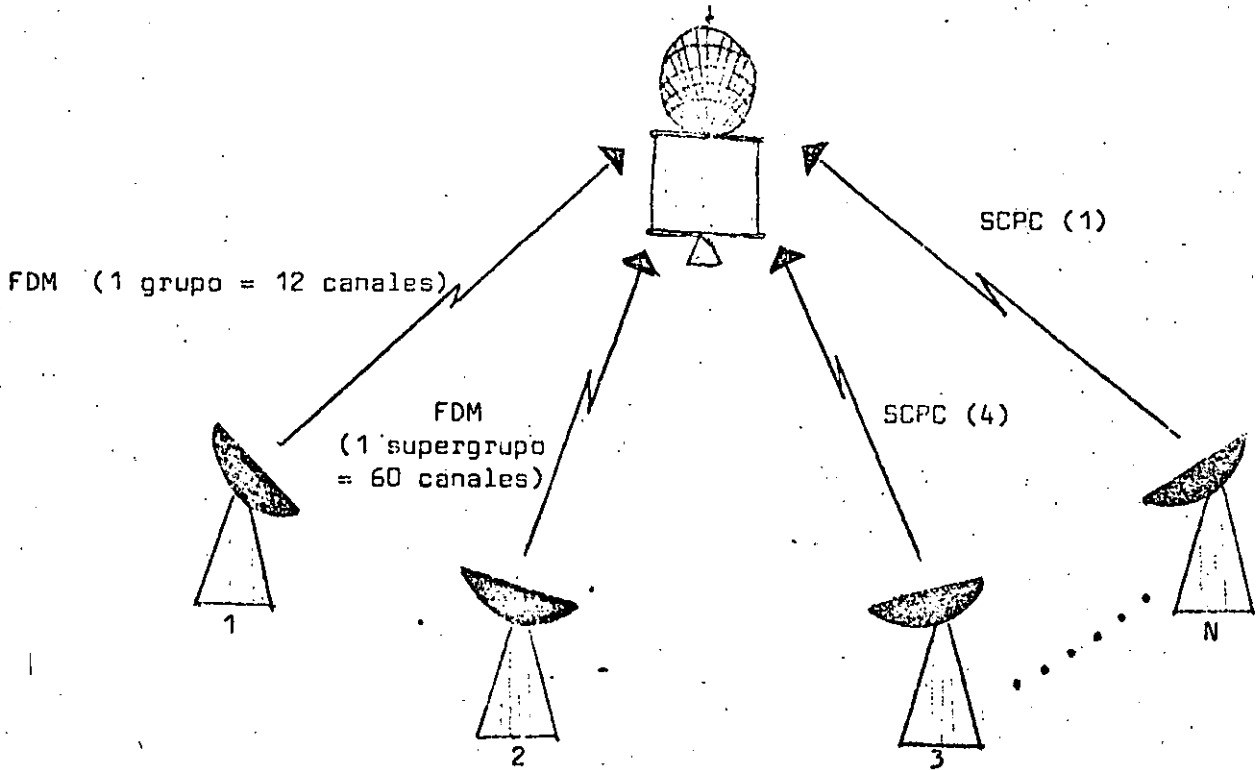


Figura 8. Ejemplificación de FDMA

205

~~205~~

214

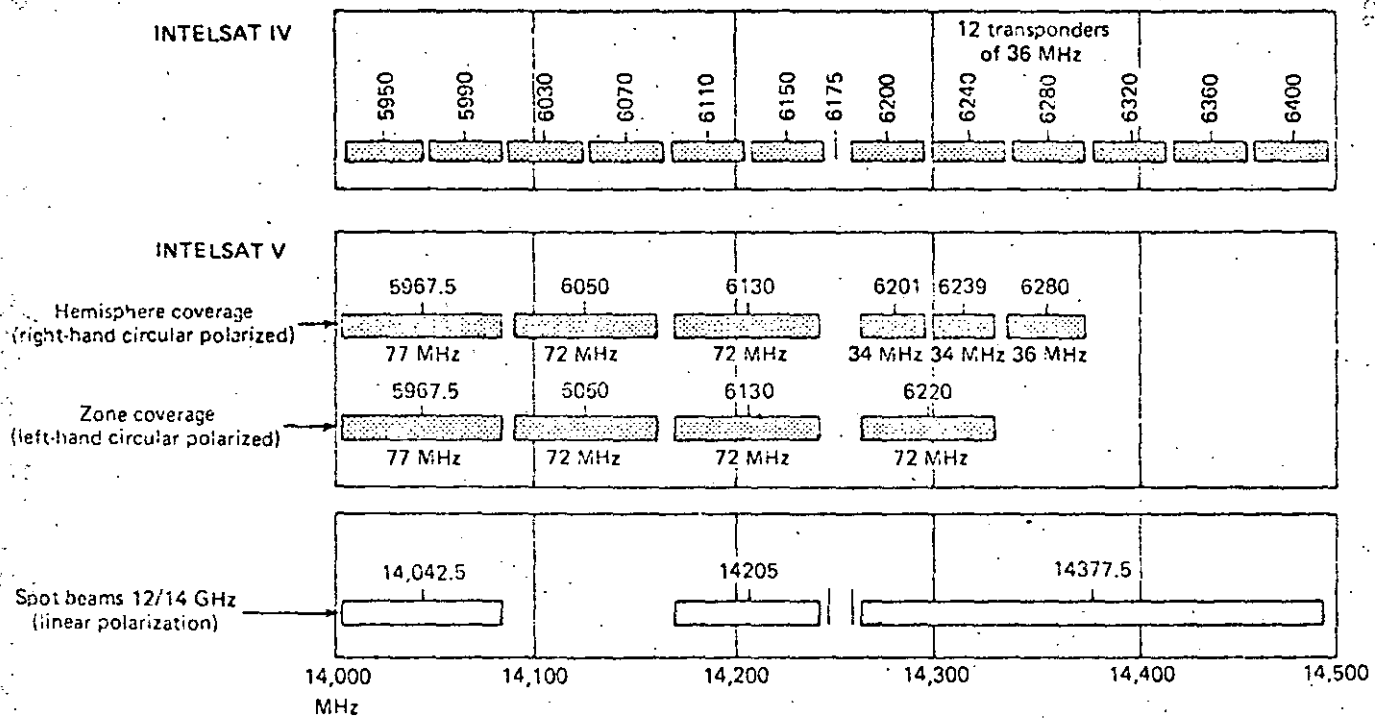
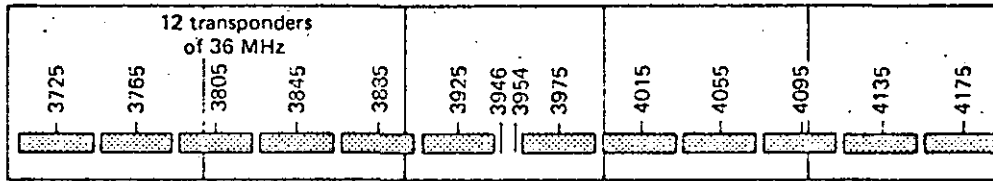


Fig. 9
Frecuencias de subida

Fig. 9 (cont.)
Frecuencias de bajada

206

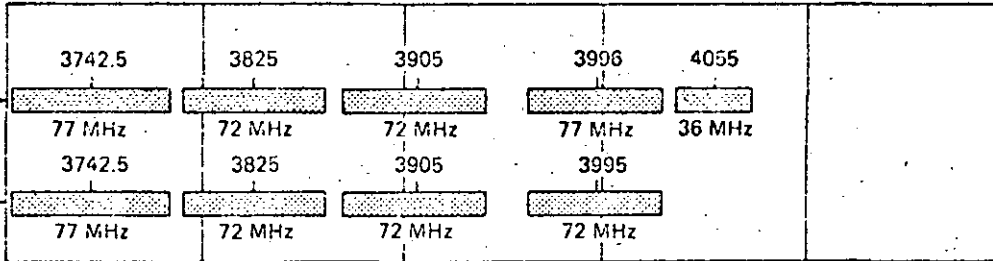
INTELSAT IV



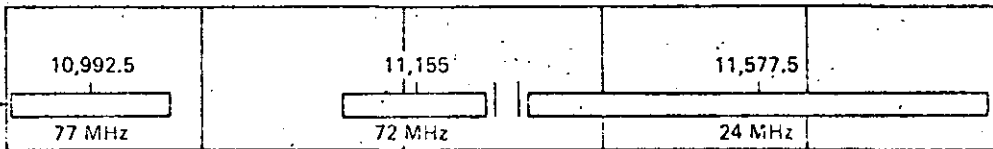
INTELSAT V

coverage
(circular polarized)

coverage
(circular polarized)



spot beams
(direction)



10,950 MHz 11,050 11,150 11,250 11,350 11,450

~~206~~

215

- FDM/FM.-

Esta es la técnica utilizada, por ejemplo, por INTELSAT IV y IV-A. Cada estación terrena rearregla los canales y grupos de canales de entrada en supergrupos de 60 canales que ocupan una banda base de 252 KHz, o bien en grupos de 12 canales cuando los requerimientos de tráfico son menores. En las figuras 10 y 11 se ilustra el proceso de FDM.

El supergrupo emitido por una estación A en particular contendrá canales con destinación diferente. Sin embargo, los 60 canales modulan en frecuencia (FM) a una portadora en el rango de los 4 GHz (la frecuencia exacta de esta portadora será la que tenga asignada la estación emisora A). Todas las estaciones terrenas situadas en diferentes partes del mundo y que reciben señales de la estación A demodulan toda la portadora, que tiene un ancho de banda de 5 MHz y extraen los canales que les correspondan.

Al haber varias portadoras presentes en el mismo transpondedor de un satélite, y debido a la característica no lineal del TWT, es necesario operar éste con varios decibeles abajo de su punto de saturación o nivel máximo de potencia de salida. A esta reducción en la potencia aprovechada se le denomina back-off (abreviado BO) de salida. Si el amplificador se operase en una región altamente no lineal, se producirían niveles muy elevados de productos de intermodulación que afectarían significativamente la calidad S/N de las señales amplificadas. En la figura 11* se muestra la característica típica entrada/salida de un amplificador TWT. Notese que el back-off de entrada no es proporcional al back-off de salida. En estas mismas notas, en la sección correspondiente a "Estructura básica de un satélite", también se muestra la relación entre el BO de salida de un TWT y la relación portadora / ruido de intermodulación en función del número de portadoras presentes. A manera de ejemplo, los satélites INTELSAT IV y IV-A operan con un BO de 7 dB en haz pincel y 4.2 dB en haz global. El número típico de canales en un transpondedor de 36 MHz en el IV-A con haz pincel es de 900, y de 450 para un haz global con varias portadoras.

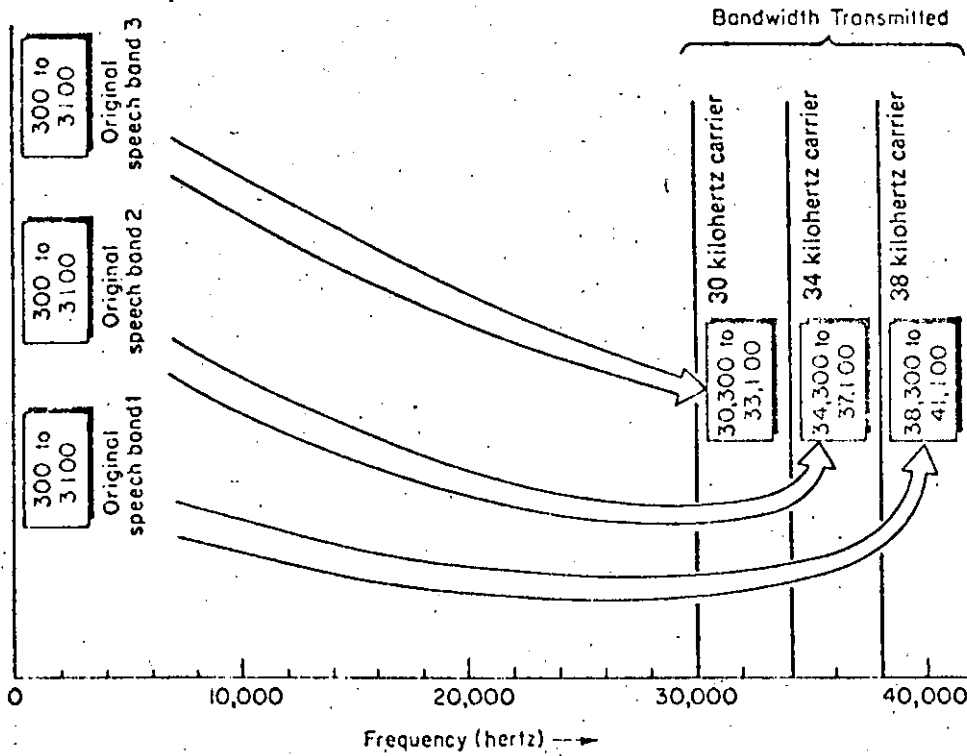
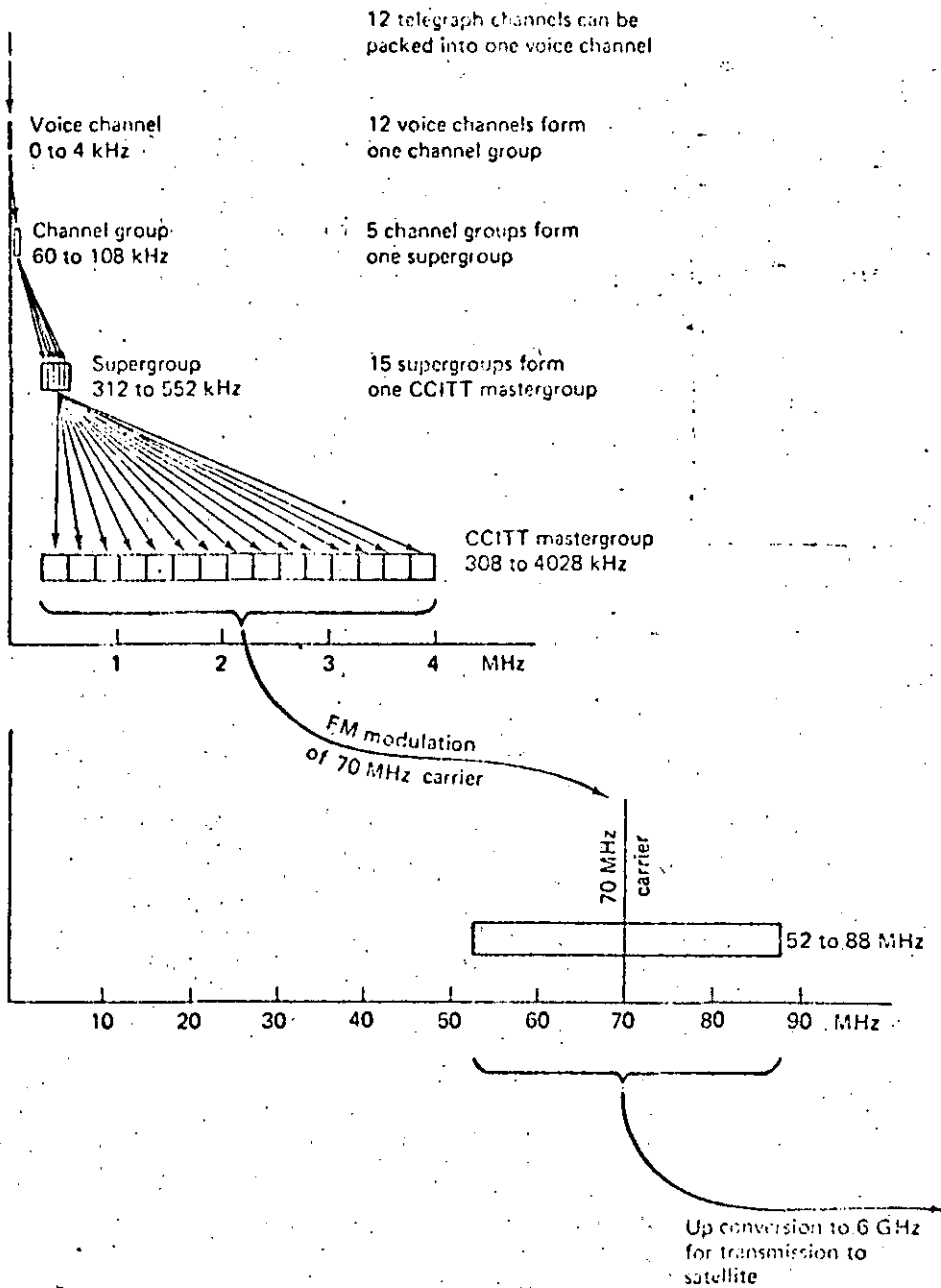
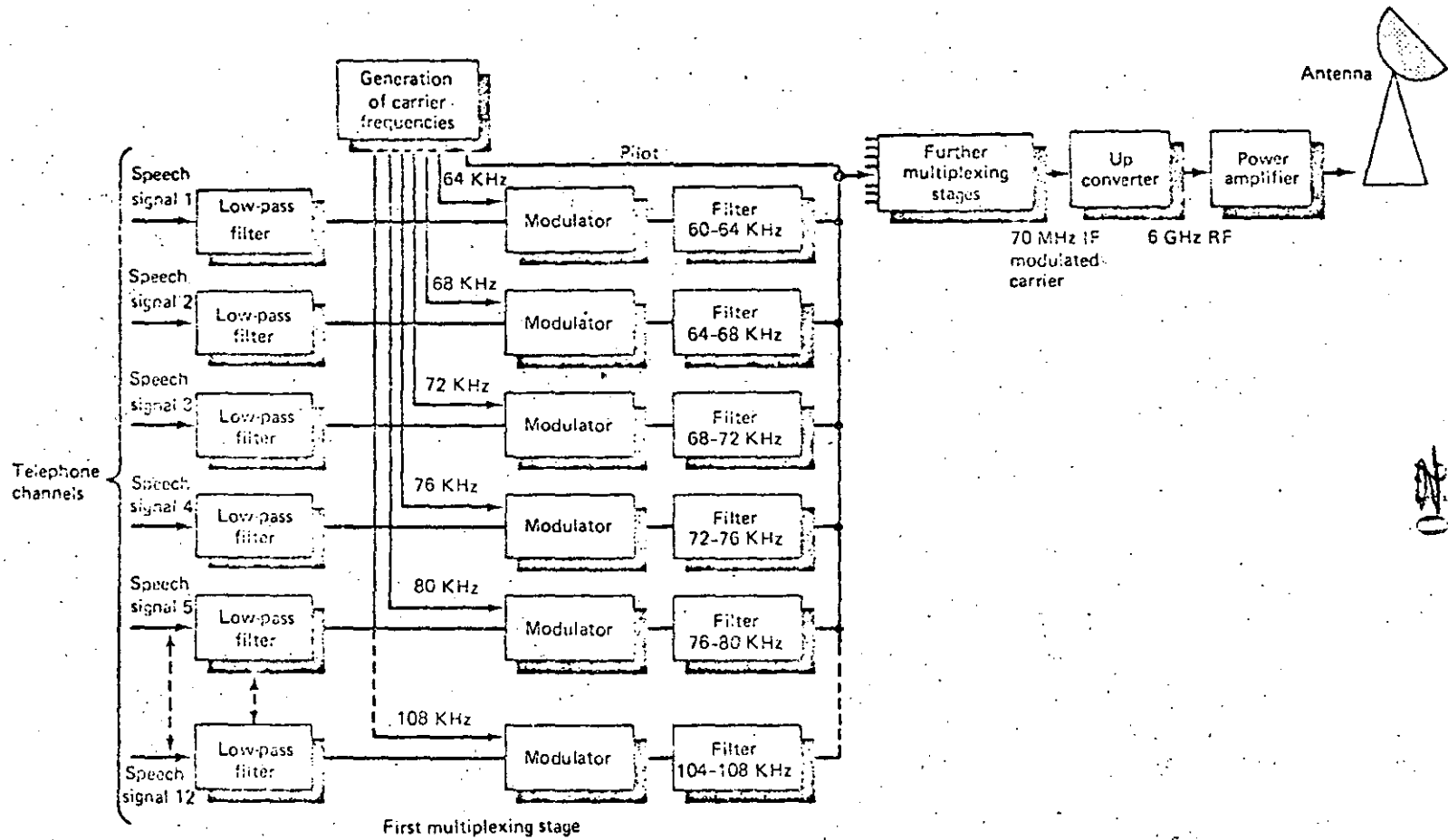


Fig. 10

~~209~~

Fig. 10 (cont.)

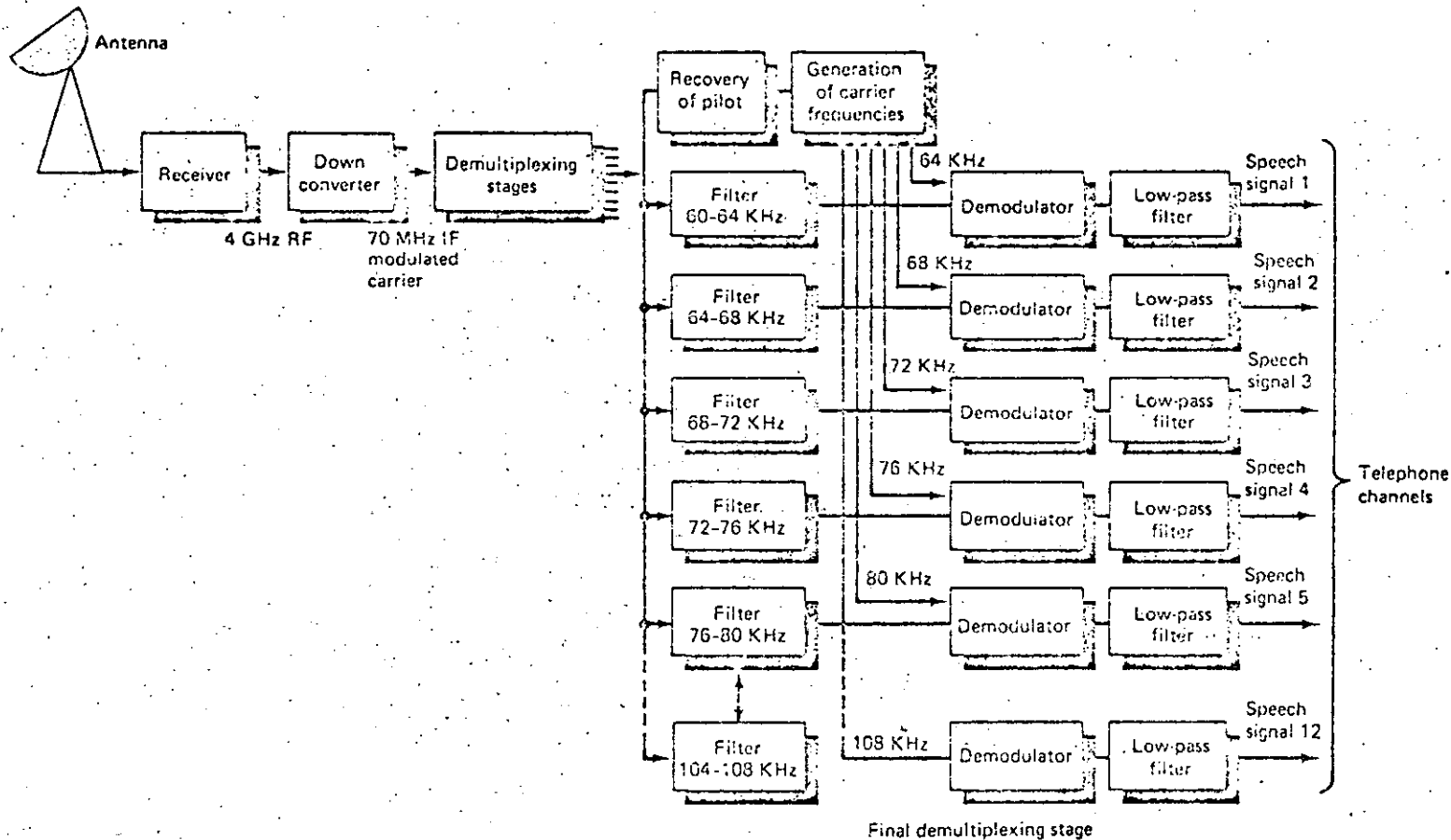




219

Fig. 11

Fig. 11 (cont.)



211

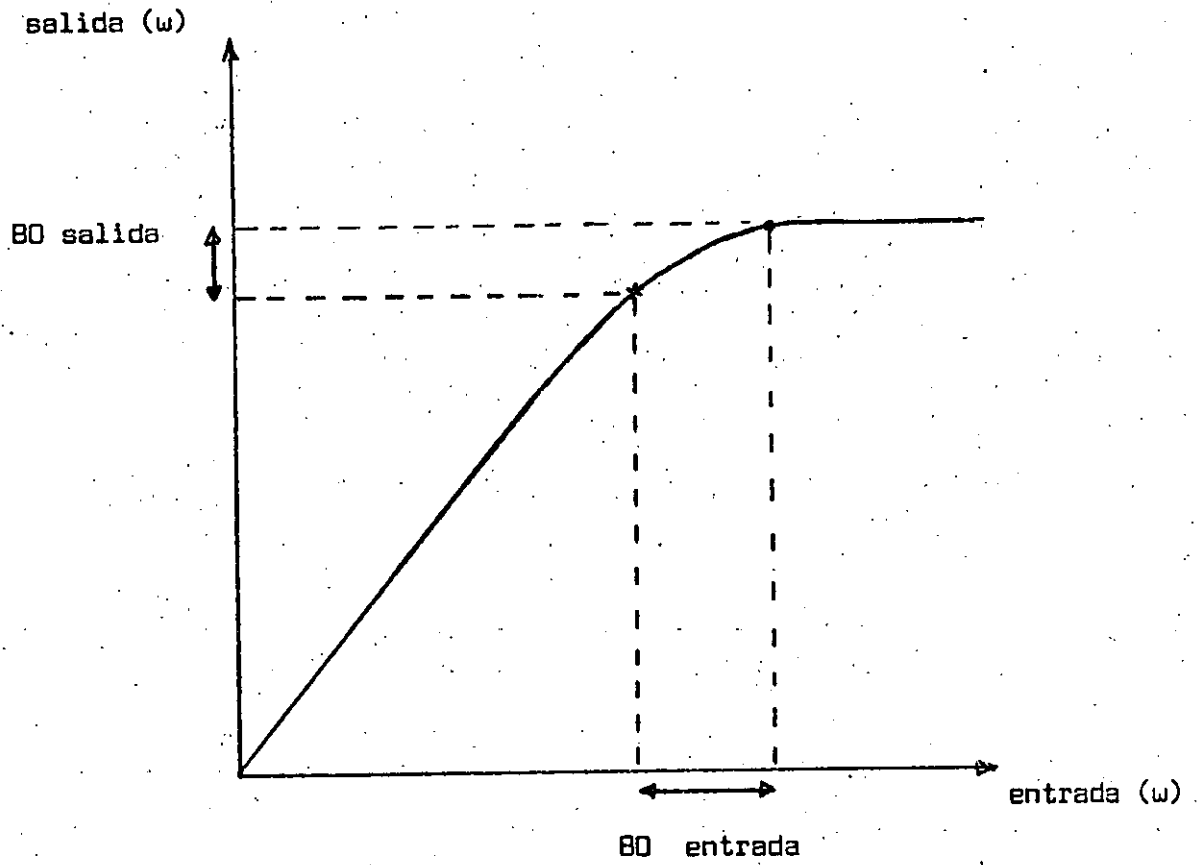
~~212~~

Fig. 11 *

Característica de
amplificación de
un TWT.

Como puede notarse, la capacidad de un transpondedor operando en FDM/FM/FDMA varía de acuerdo al número de portadoras, que está íntimamente ligado al número de estaciones accedando el transpondedor. En la tabla I se ilustra esta variación en capacidad.

Tabla 1. Capacidad de un transpondedor de 36 MHz en función del número de portadoras.

No. de portadoras	Ancho de banda por portadora (MHz)	No. de canales por portadora	No. total de canales en el transpondedor
1	36	900	900
4	3 de 10 y 1 de 5	132 60	456
7	5	60	420
14	2.5	24	336

Los transpondedores de 36 MHz normalmente se operan con portadoras moduladas en FM y con ancho de banda de 2.5, 5 ó 10 MHz. Ocasionalmente se usa todo el transpondedor por una sola portadora para telefonía (en estos casos especiales se tiene acceso único y no múltiple). Por lo que respecta a TV, se puede tener un canal en una portadora de 36 MHz, o dos canales en portadoras de 18 MHz c/u usando filtros especiales e igualadores de retraso de grupo. En el caso de México, se transmite TV por los satélites INTELSAT IV y WESTAR IV y en ambos casos se opera en 2 canales de TV de 18 MHz c/u por transpondedor.

FDM/FM/FDMA es muy ineficiente en el aprovechamiento de espectro en el sentido de que cada enlace entre dos estaciones tiene asignada una frecuencia única que no puede ser utilizada por ningún otro enlace en ningún momento, a menos que se emplee re-utilización de espacio (SBMA) o de frecuencia con otra polarización. Si se consideran, por ejemplo, los enlaces internacionales entre México y Europa a través del Atlántico, se observa que las horas de mayor demanda de tráfico están entre las 12 y 17 hrs. en Europa y entre 7 y 12 hrs. en México, cuando hay personal trabajando en las oficinas de ambos lados del océano. Fuera de estas "horas pico" existe muy poca demanda de tráfico para canales de telefonía, pero los canales podrían utilizarse, por ejemplo, entre México y Sudamérica. Esto conduce a considerar otras técnicas de acceso al satélite en FDMA, como son SCPC de asignación fija y por demanda (DAMA y SPADE).

En la tabla 2 se proporcionan algunos datos relativos al tráfico manejado por la estación internacional de Tulancingo.

Tabla 2. Algunos enlaces vía satélite operados por Tulancingo 1 y 2.

Enlace entre México y	Tx, MHz	Rx, MHz	Tipo de acceso y nº de canales
España	5990.625	3765.625	Asig. fija (1 grupo de 12 c.)
Italia	5984.0	3759.0	" "
Brasil	6038.5	3813.5	" "
Chile	6280.5	4065.5	" "
Venezuela	6077.25	3852.25	" "
Alemania	14060.25	3760.25	" "
Francia	14032.0	3732.0	" "
Inglaterra	14077.25	3777.25	" "
Francia	6042.75	3817.75	" "
Inglaterra	6242.75	4017.5	" "
Cuba	—	—	" 6 canales SCPC
Países participantes de SPADE	—	—	SPADE 12 canales SCPC

- SCPC (Single Channel Per Carrier ó
Canal Único por Portadora)

224

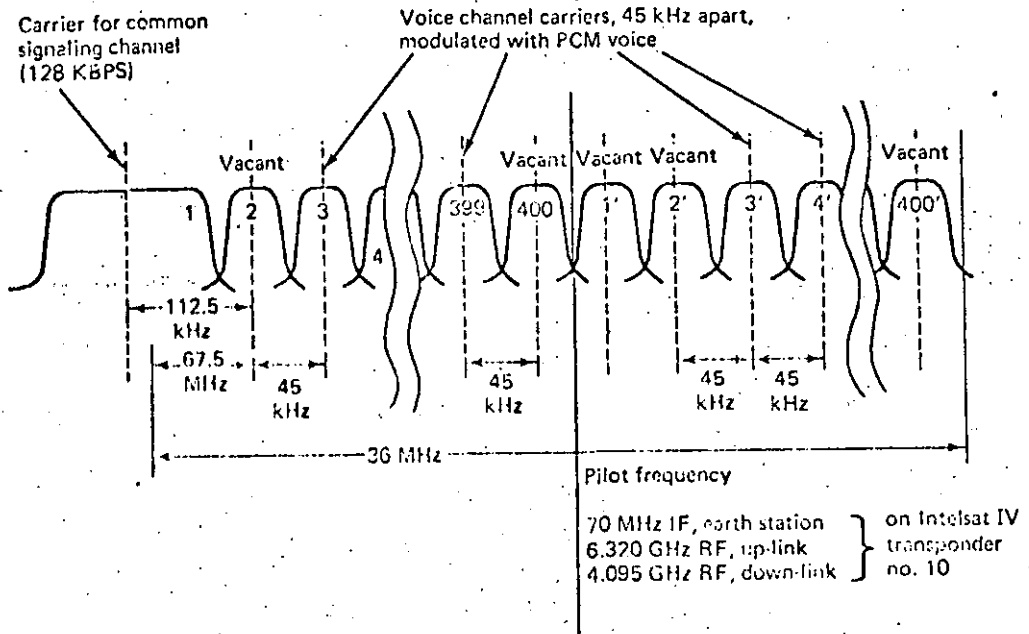
~~915~~

La técnica SCPC tiene gran aplicación cuando se desean interconectar estaciones terrenas de muy baja capacidad o demanda de tráfico. Consiste en que a cada canal de telefonía se le asigna una frecuencia portadora de RF, misma que es modulada por la señal de voz en FM o PSK. Dado que las llamadas son aleatorias, el espectro del transpondedor se puede aprovechar eficientemente si las frecuencias portadoras de RF se asignan temporalmente a las estaciones terrenas, es decir, únicamente mientras tengan información que enviar. Cuando una estación A termina de transmitir su información, la frecuencia de portadora que se le había asignado pasa a un "banco de frecuencias" controlado por una computadora central. Si otra estación B desea entonces establecer un enlace, la computadora central le -- asignará una de las frecuencias disponibles en el "banco" y quizás se le otorgue la misma frecuencia que antes había utilizado la estación A. Como el sistema funciona en base a este banco de frecuencias y al criterio de "servicio a quien pida primero", la técnica recibe el nombre de DAMA (Demand Assignment Multiple Access ó Acceso múltiple de asignación por demanda). Cuando los canales de voz están codificados en PCM (de acuerdo a recomendaciones vigentes de la CCITT), la técnica se conoce como SPADE -- (Single-Channel-per carrier PCM multiple-Access Demand assignment Equipment ó equipo de asignación por demanda en acceso múltiple para canal PCM único por portadora).

INTELSAT IV fue el primer satélite en utilizar SPADE en uno de sus transpondedores. La figura 12 muestra las 800 ranuras de frecuencia en las que se divide un transpondedor de 36 MHz. Se tienen 800 portadoras de RF diferentes, de las cuales 794 se emplean para establecer 397 circuitos telefónicos (un circuito ocupa dos ranuras para el canal de la persona A y el canal de la persona B). El espaciamiento entre cada ranura o canal es de 45 KHz. Nótese que en el extremo izquierdo se tiene una ranura

~~216~~

Fig. 12



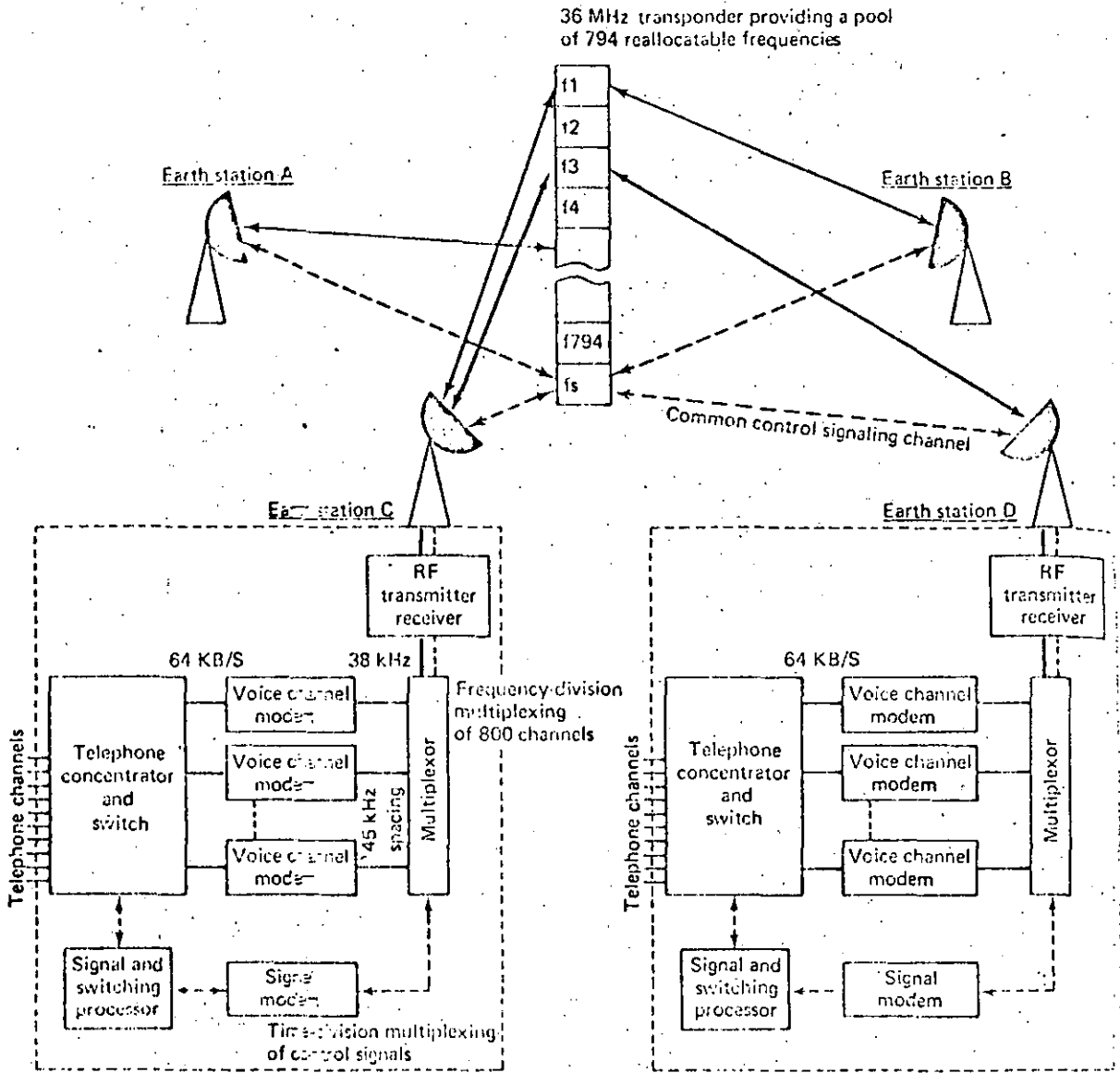
de mayor ancho de banda; se utiliza para el canal de canalización y en él se transmiten 128 000 bps. Este canal es el que contiene la información variante con el tiempo de qué frecuencias están utilizando unas estaciones y cuales están disponibles para nuevas solicitudes de transmisión.

En páginas anteriores, en la Tabla 1, se observó que conforme aumenta el número de portadoras también decrece drásticamente la capacidad en número de canales del transpondedor. De aquí surge la pregunta: ¿cómo es posible tener 800 portadoras en un solo transpondedor? Existen dos razones que justifican la estructura del sistema SPADE:

- 1a. Al tener un solo canal por portadora, ésta se puede apagar (cero potencia transmitida) cuando no haya voz presente, lo cual sucede cuando menos el 50% del tiempo en que uno establece una conversación, ya que algunas veces uno solamente escucha, y aún hablando se producen pausas entre palabras. Esto provoca que en realidad, se tengan menos de 400 portadoras encendidas al mismo tiempo en un transpondedor.
- 2a. Los grupos y supergrupos de canales multiplexados en la Tabla 1 son modulados en FM y ocupan más ancho de banda que su equivalente digital. Los canales SPADE son modulados con PSK de cuatro fases; cada canal se codifica en PCM a 64 000 bps y se obtiene una buena calidad subjetiva con espaciamentos de 45 KHz entre canales.

Como puede verse, esta técnica es atractiva, aunque su costo aumenta con respecto al de asignación fija ya que se requiere contar con un complejo controlador DAMA en cada estación.

En la figura 13 se ilustra el esquema de operación de SPADE. todas las estaciones utilizan secuencialmente todo el canal común de señalización, empleando PSK de dos fases. Para ésto, a cada estación se le asigna un milisegundo para transmitir 128 bits; algunos de ellos son de sincronización, otros de detección de errores y otros de información sobre enlaces en operación y "nuevas



The operation of the SPADE frequency-division demand assignment system.

Fig. 13

solicitudes". Cada estación dispone de su ranura de tiempo cada 50 milisegundos para actualizar su banco de datos. Por lo tanto, se pueden enlazar hasta 49 estaciones. En la figura 14 se muestra la utilización del canal común de señalización, y en la Tabla 3 se indican las principales características de un canal SPADE.

Tabla 3. Características principales de un canal SPADE

	Canal de comunicación	Canal de señalización
codificación	PCM	_____
modulación	PSK-4 ϕ coherente	PSK - 2 ϕ
velocidad	64 kbps	128 kbps
ancho de banda	38 KHz	_____
espaciamiento entre canales	45 KHz	_____
estabilidad requerida	\pm 2 KHz	_____
tasa de errores	10^{-4}	10^{-7}
acceso	FDMA-SCPC-asignación por demanda	TDMA
longitud del marco	_____	50 mseg.
longitud de la ráfaga de datos	_____	1 mseg.
número de accesos	397	49 más una estación de referencia para sincronización

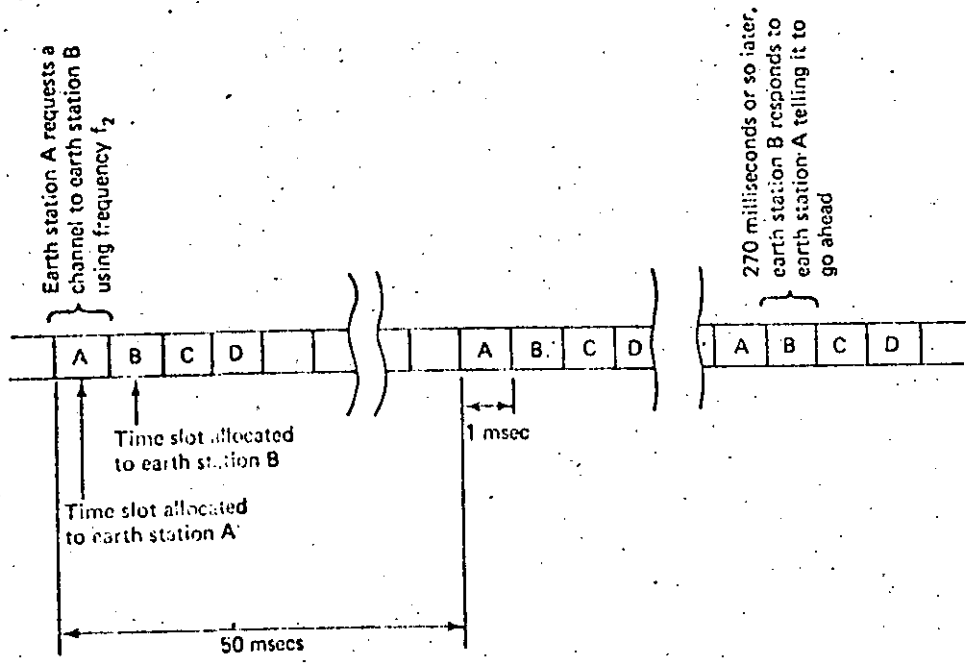


Fig. 14

Acceso múltiple por división en tiempo (TDMA)

En páginas anteriores se mencionó que la característica de amplificación de un TWT es no lineal y que si se opera cerca de saturación, se producen niveles elevados de ruido de intermodulación, que afectan la calidad de las señales transmitidas.

Además, se indicó que el ruido de intermodulación puede reducirse operando al amplificador con un back-off. El posible efecto de estos productos de intermodulación que se salen de la banda de una portadora determinada, puede visualizarse con ayuda de la figura 15. En ella se muestran los resultados experimentales al enviar a través de un transpondedor de un satélite ANIK canadiense a dos tonos de prueba. El experimento consistió en aumentar la intensidad de las dos señales hasta saturar el transpondedor. Al reducir por 3 dB al tono de entrada de mayor frecuencia, se observa una distribución de ruido de intermodulación como la de la figura 15.

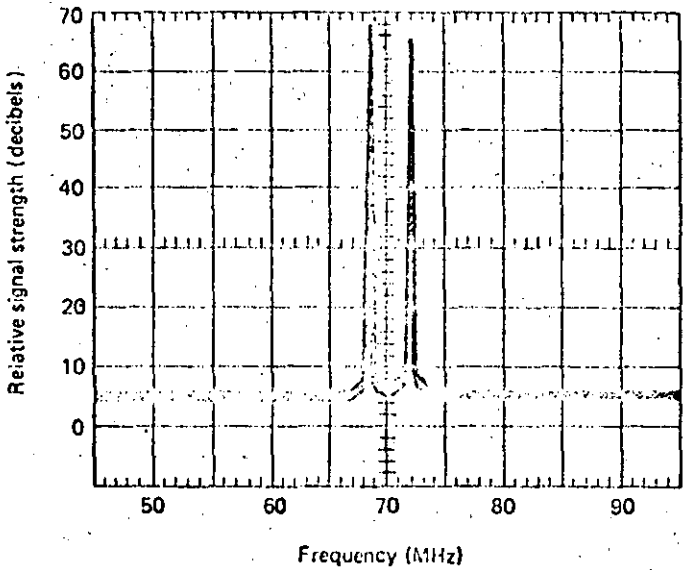
El concepto básico de TDMA consiste en usar una sola portadora de banda ancha que ocupe todo el transpondedor. Esto permite operar el satélite a máxima potencia, es decir, en saturación, aún cuando opere en su región no lineal. Se tiene la ventaja de que también en tierra, las estaciones pueden operar en saturación al transmitir. El funcionamiento de un sistema TDMA es el siguiente:

- A cada estación terrena se le asigna secuencialmente un intervalo de tiempo para que utilice todo el transpondedor. La estación puede transmitir dentro de este intervalo una portadora saturada de 36 MHz que contenga información digital mezclada de voz, datos y video.
- En su forma más simple, a todas las estaciones se les asignan secuencialmente intervalos de tiempo de la misma longitud, en forma similar al uso del canal de señalización del sistema SPADE.

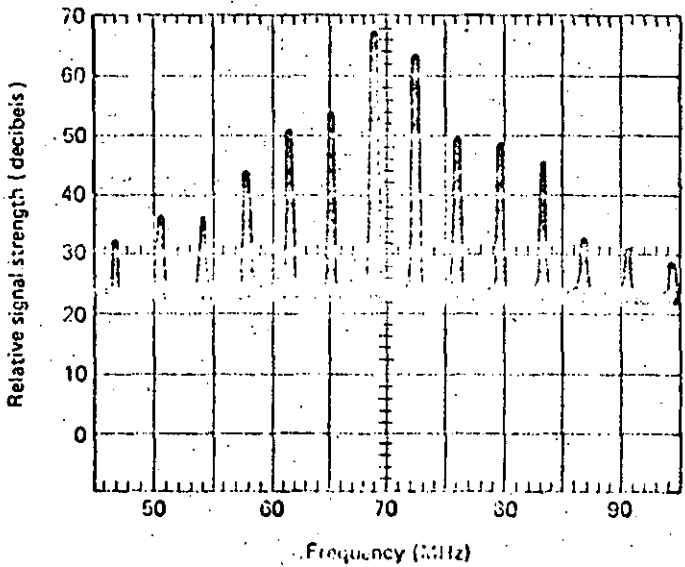


Fig. 15

TWO TONES ARE TRANSMITTED TO THE SATELLITE AS SHOWN:



THE FOLLOWING SIGNAL IS RECEIVED AT EARTH STATIONS, SHOWING HOW INTERMODULATION HAS OCCURRED BETWEEN THE TWO TONES:



An example of the intermodulation that occurs when multiple carriers are transmitted via the same transponder. (Drawn from cathode ray tube photographs in reference 1.)

- Para operar más eficientemente, cada estación debe tener la flexibilidad de variar su velocidad de transmisión, - de modo que las ranuras de tiempo asignadas deben ser de longitud variable (de acuerdo a la demanda o solicitud - de cada estación), o bien, las estaciones que así lo necesiten deben tener preferencia y poder transmitir con mayor frecuencia.
- La mayoría de los sistemas operan bajo asignación por de manda. Para éllo se tiene un canal de control que infor ma a todas las estaciones sobre las asignaciones efectua das y recibe nuevas solicitudes. A este canal se le deno mina algunas veces como canal de servicio (order wire).

El sistema TDMA es muy atractivo, pero requiere de equipo altamente confiable de sincronización. El problema no se limita a asignar intervalos a las estaciones, en forma similar a la de un equipo de conmutación TDM, sino que deben considerarse los - desplazamientos del satélite con respecto a su posición normal.

Los satélites están sujetos a varios fenómenos naturales que alteran sus posiciones a largo y corto plazo. Simplemente, en un lapso de 8 días, pueden sufrir oscilaciones de posición - como las mostradas en la figura 16, que son efecto de las fuerzas de atracción del sol y la luna. Al cambiar la posición de un satélite, aumenta o disminuye la distancia directa estación X- satélite y, por consiguiente, varía el tiempo de propagación de la señal binaria.

Un transpondedor típico de 36 MHz puede manejar 60 Mbps en QPSK. A estas velocidades, el tiempo entre bits es de 16.67 na nosegundos, y de acuerdo a la figura 16, en donde se muestra la velocidad de alejamiento del satélite con respecto a su posición normal, puede haber variaciones en el tiempo de propagación hasta de 2 nanosegundos, por lo que se requiere mantener una sincro nización constante.

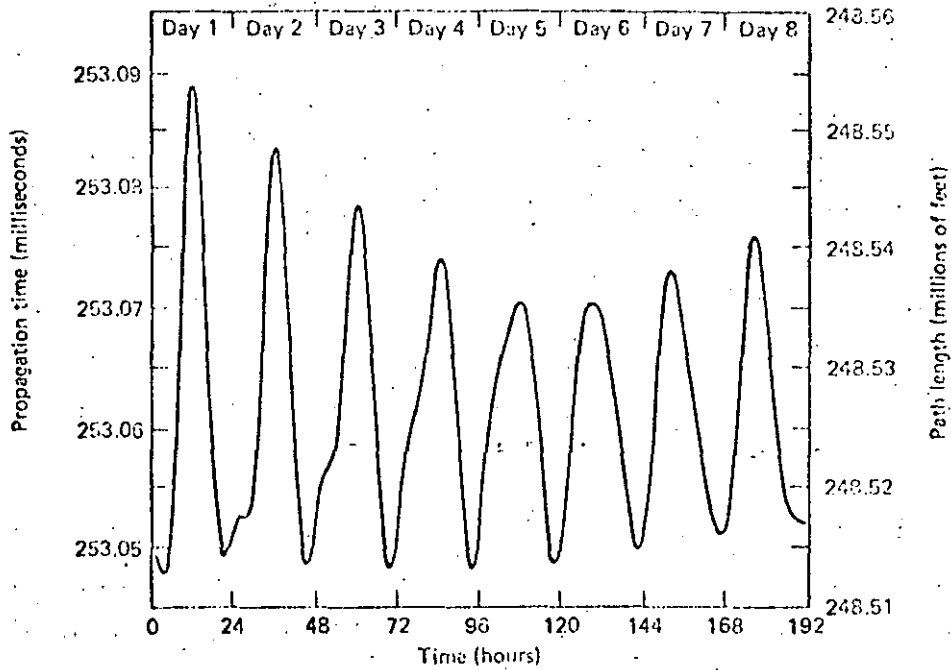
En las figuras 17 y 18 se muestran las estructuras de un marco maestro en TDMA. La duración típica de un marco es de 1 milise-gundo, o sea que tiene capacidad para la transmisión de 60 000 bits. La primera ráfaga de bits del marco sombreada en la figura 17, es el canal de supervisión; lo transmite una estación central de control y contiene información de sincronización y de identificación del marco.

La duración de un marco maestro es variable y depende de la demanda de tráfico por cada estación terrena. Un marco maestro está formado por varios marcos, todos iguales, en donde cada estación tiene asignadas ranuras de tiempo fijas. Al variar la demanda, se envían nuevas instrucciones en la ráfaga de la estación central de control, indicando una nueva distribución de tiempos o configuración de marcos, e iniciándose de esta forma un nuevo marco maestro.

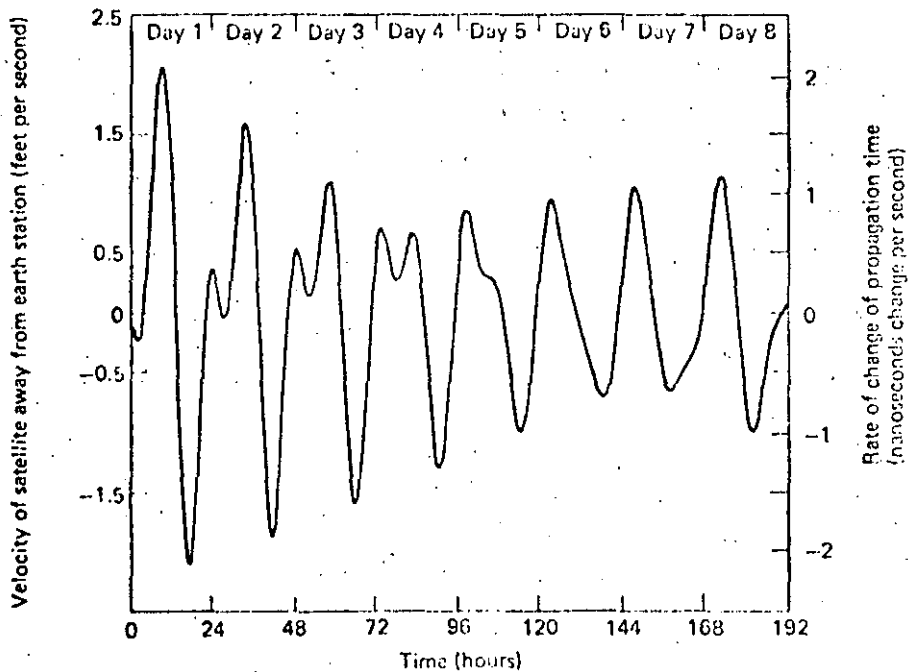
Por lo que respecta a la ráfaga de bits enviada por cada estación, ésta debe contener un preámbulo o encabezado para sincronización e identificación, seguido de la información que se desea transmitir. En la figura 19 se ilustra la estructuración de un marco, incluyendo los bits de control, del sistema de COMSAT denominado MATE.

Como complemento final de esta sección, a continuación se ane-xan algunos diagramas ilustrativos sobre el modo de acceso y el uso de los transpondedores de los satélites canadienses ANIK B y C, en las bandas C y Ku.

Fig. 16



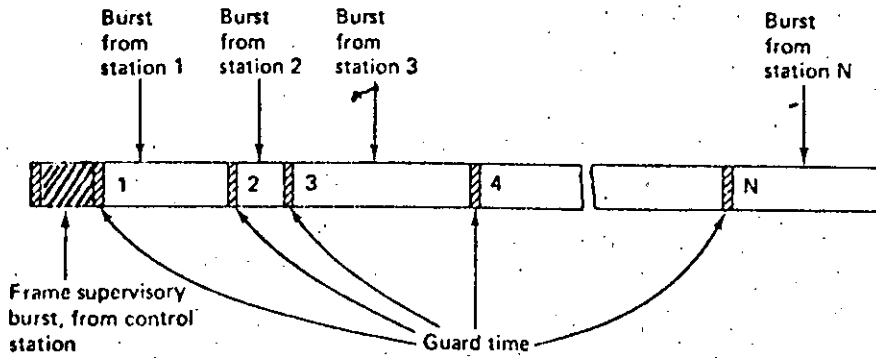
Variations in path length and propagation time via a satellite, measured over an 8-day period



Variations in velocity of the satellite relative to an earth station, for the same 8 days

"Tidal" variations in satellite position. A high-speed digital satellite link needs careful synchronization.

~~225~~



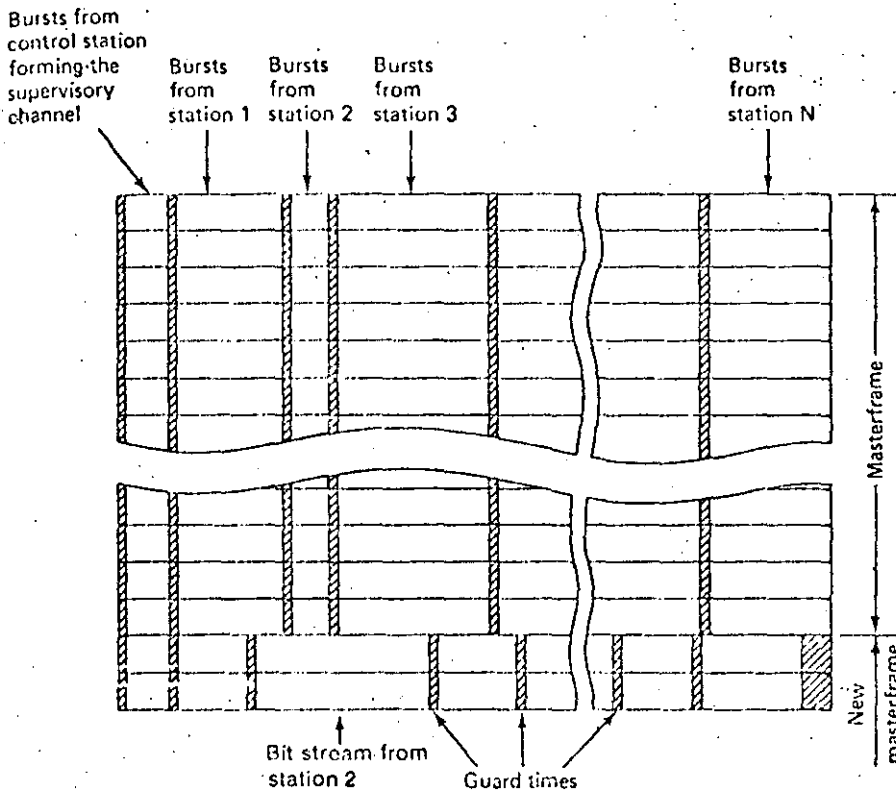
225

A frame in a TDMA system. A typical frame length is on the order of 1 millisecond.

Fig. 17

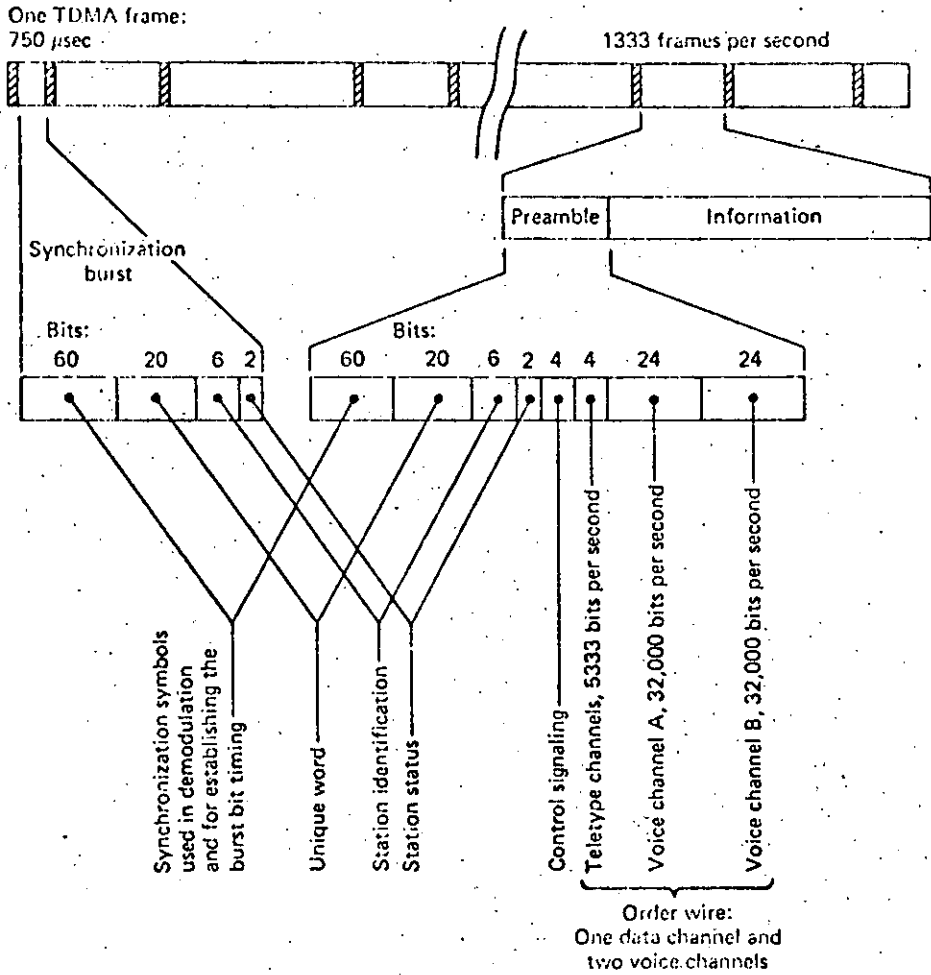
Fig. 1B

226



A given number of frames follow one another, forming a masterframe. The vertical columns form a continuous bit stream from each earth station containing channels to different earth stations. The burst size allocations will be different in each masterframe if the channel demands vary. Only the supervisory channel will remain the same.

Fig. 19



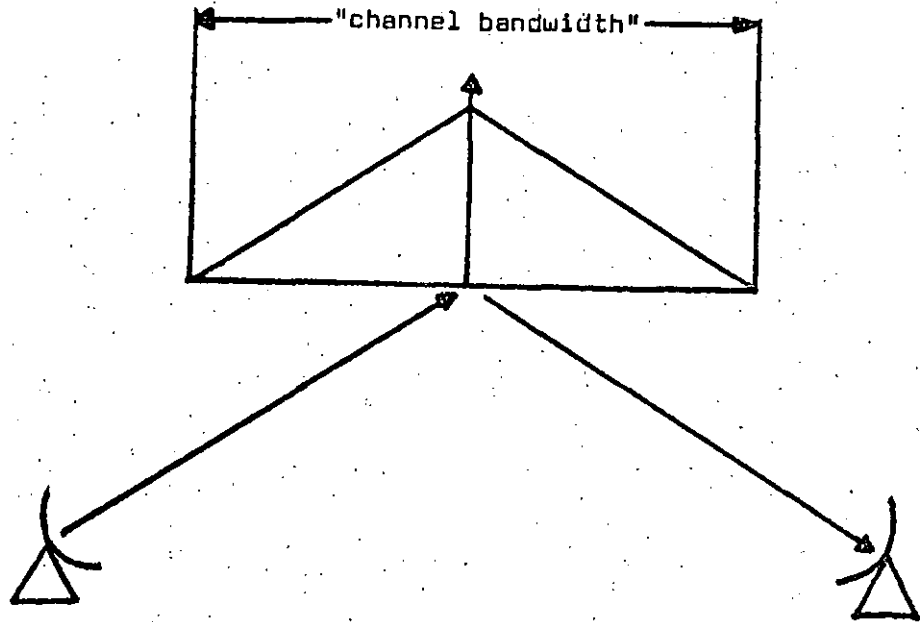
Bits used for synchronization and control of TDMA frames on the Comsat MATE system [2].

~~238~~

238

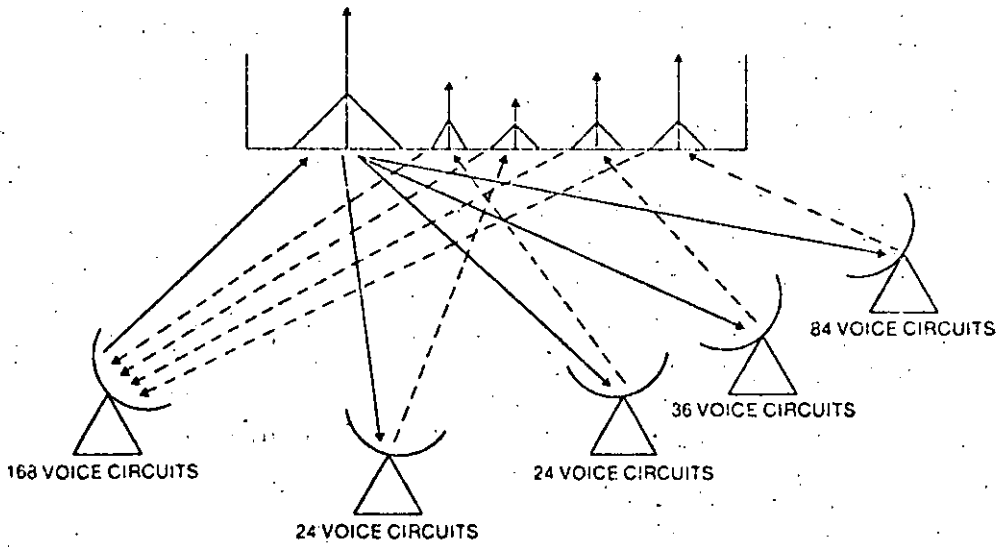
Diagramas ilustrativos sobre el modo
de acceso y el uso de los transpondedores
de los satélites ANIK B y C.

Heavy Route Message Traffic (Frequency Modulation -- Single Access)



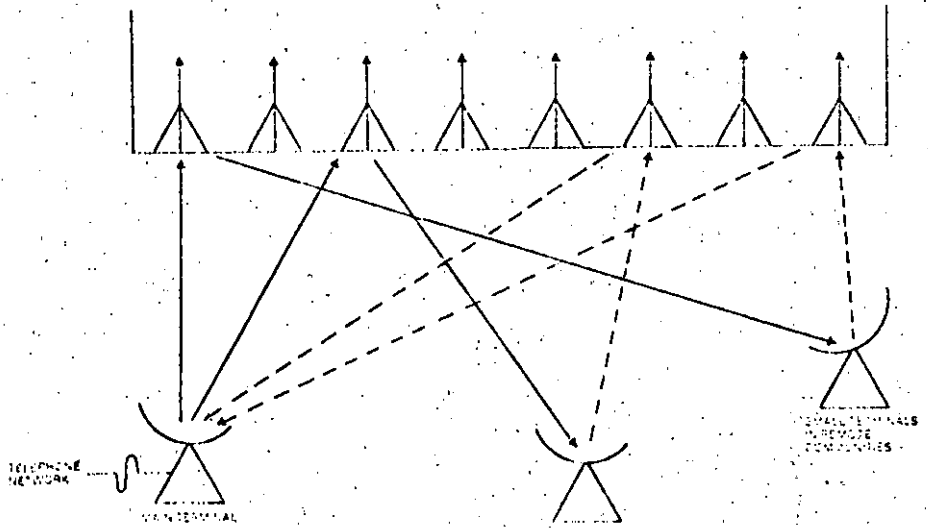
230

Medium Density Message Traffic (Frequency Division Multiple Access (FM/FDMA)

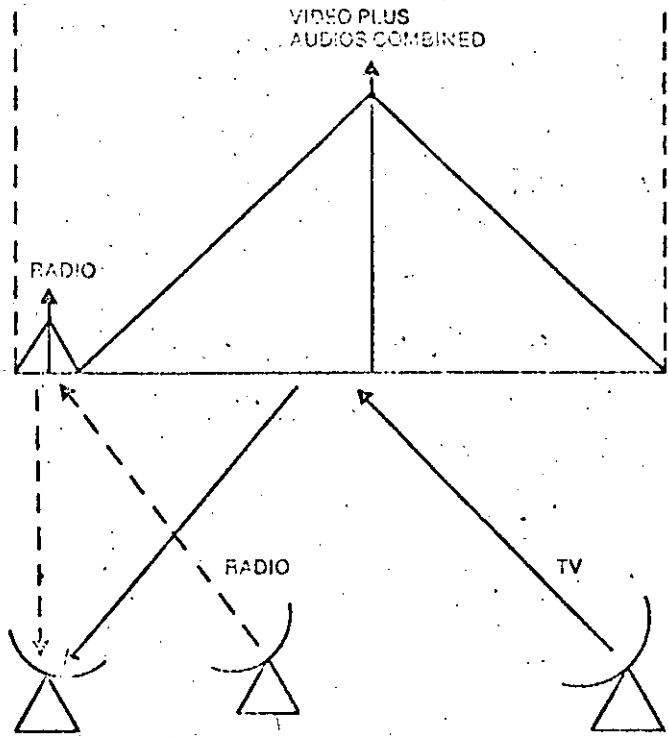




Thin Route Message Traffic (Single Channel Per Carrier SCPC/FDMA)



Television / Radio Channel





Earth Station Characteristics - Message Facilities

233

TRAFFIC	ANTENNA DIAMETER (m)	G/T (dB/K)	QUALITY	POWER BACK UP	REDUNDANCY	
Heavy Route	30	37.5	37.5 dBrcO	Batteries & Generator	Yes	
Medium Density FM/FDMA PCM/TDMA	a 30	37.5	37.5 dBrcO	Batteries & Generator	Yes	
	b 10	28	44.0 dBrcO	Batteries & Generator	Yes	
	c 8	27.5	44.0 dBrcO	Batteries & Generator	Yes	
	a 30	37.5	34 dBrcO	Batteries & Generator	Yes	
	b 10	31	34 dBrcO	Batteries & Generator	Yes	
	Thin Route Message	a 30	37.5	Idle Noise 37.5 dBrcO max.	Batteries & Generator	Yes
Transportable	b 10	28	Customer Provided		Yes	
	c 8	26	Batteries		Yes	
	d 4	22	Batteries		Yes	
	e 4.5	21	Batteries		Yes	
	a 3.6	19	Batteries		Can be provided	
	b 3.6	19	No		No	
	Light Route TDMA	4.5	22		Idle Noise 35 dBrcO max.	No

Earth Station Characteristics - Television & Radio

234

TRAFFIC	ANTENNA DIAMETER (m)	G/T (dB/K)	QUALITY	POWER BACK UP	REDUNDANCY
Network TV (Transmit/Receive)	a 30 b 10	37.5 28	54 dB Video S/N	Batteries & Generator	Yes Yes
Northern TV (Transmit only)	a 11 b 8	NA NA	Min 45 dB Video S/N	Customer Provided	No No
Remote TV (Receive Only)	a 8 b 8 c 4.5	26 22 21.5	48 dB Video S/N	Some Have Batteries	Some Have
Frontier TV (Receive Only)	a 4.5 B 3.6	18.5 18.5	45 dB Video S/N	No No	No No
Transportable TV (Transmit/Receive)	a 4.5 b 4.5	NA NA	48 dB Video S/N	Generator No	Yes No
Facsimile Transmit Receive	8.0 4.5	NA 21.5	Better than 85 line screen	No No	No No

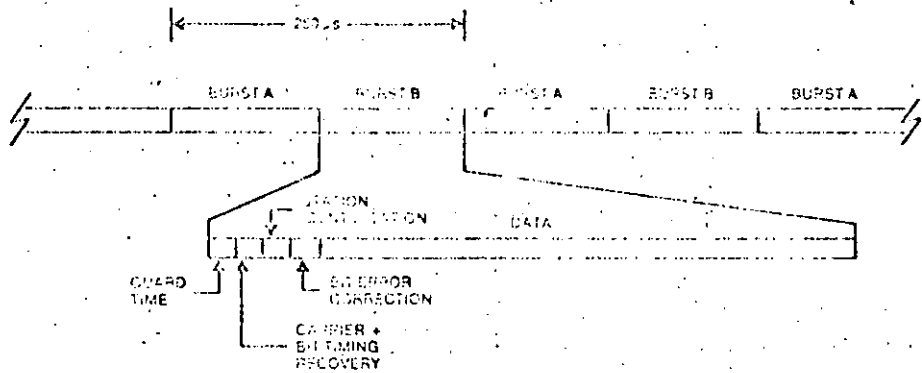
Earth Station Characteristics - 14/12 GHz Facilities

235

TRAFFIC	ANTENNA DIAMETER (m)	G/T (dB/K)	QUALITY	POWER BACK UP	REDUNDANCY
Digital Message	8	35	BER 10^{-7}	Customer Provided	Yes
Television	a 8	35	48.54 dB Video S/N	Customer Provided	Yes
	b 8	29.5			
	c 4.5	26.5	46.52 dB Video S/N	As Required	As Required
Television Receive Only	a 1.8	16.5	40-42 dB Video S/N	No	No
	b 1.2	13	42 dB Video S/N (Typical)	No	No
Transportable TV Transmit Transmit/Receive	1.8 3.7	N/A 25	43 dB Video S/N	Generator	No

~~236~~

Medium Density Message Traffic (Time Division Multiple Access — TDMA)



2.8 SUPRESORES Y CANCELADORES DE ECO

En toda conexión telefónica ocurren ecos debido al desacoplamiento de impedancias en el circuito híbrido de conversión de 2 a 4 hilos. El eco consiste en que parte de la señal de entrada al híbrido se refleja por la trayectoria de salida hacia el extremo desde donde se originó dicha señal de entrada. La magnitud y característica espectral del eco depende del circuito que se establece para cada conversación telefónica en particular (diferentes alternativas de enlace y combinaciones conversador 1/conversador 2), de tal forma que resulta imposible agregar en el híbrido una impedancia fija de compensación para todas las llamadas.

El eco es particularmente severo en enlaces vía satélite, debido a que el viaje redondo (salto de ida + salto de regreso) puede tomar hasta 0.6 segundos (0.25 X 2 seg. + retraso en el enlace terrestre).

Para enlaces vía satélite existen dos alternativas para reducir ó eliminar los efectos del eco, usando:

- supresores de eco
- 6 - canceladores de eco.

En un supresor de eco, se introduce un dispositivo que determina qué persona está hablando, y se inserta una pérdida muy grande en la trayectoria de regreso. La desventaja de los supresores de eco es que tienden a "cortar" la parte inicial de las palabras y provocan interrupciones molestas en la conversación (chopping).

Un cancelador de eco no causa el molesto "chopping" de los supresores de eco, ya que consiste en un circuito que

genera una réplica del eco, incluyendo retrasos, y la resta de la señal en la trayectoria de regreso. A continuación se anexan detalles sobre el modelo 4B ECHO CANCELER de AT & T International, desarrollado en los laboratorios Bell. Consiste básicamente de un circuito integrado a muy grande escala (VLSI) que contiene 50,000 transistores. Se adapta a cualquier híbrido y cancela el eco en el punto donde se origina.

Pruebas subjetivas han revelado que el usuario prefiere la cancelación del eco, a su supresión, especialmente en enlaces vía satélite. Simplemente en Estados Unidos existen en operación más de 60,000 canceladores fabricados por Western Electric en circuitos terrestres y vía satélite.

Otro ejemplo de cancelador de eco, es el modelo EC-5000 de TeleSystems, subsidiaria de la compañía COMSAT (se anexa copia del catálogo). Este es un cancelador digital multicanal, a diferencia de los canceladores tradicionales de canal único. Opera en configuración full-duplex con circuitos de estándar americano T1 de 24 canales de voz, a 1.544 Mbps. A cada canal de voz de 64 Kbps (codificado en PCM con 8 bits) se le asigna un procesador individual de cancelación de eco, que inserta una cancelación del orden de 45 dB.

A continuación se anexa información relevante respecto a pruebas subjetivas realizadas por INTELSAT, un estudio comparativo de la RCA sobre supresores y canceladores de eco, pruebas subjetivas realizadas por la AT & T, y estandarización de la CCITT.

249

~~239~~

CANCELADOR

DE

ECD

239

4 B - A T T

ECHOES ECHOES

AT&T

ONCE UNAVOIDABLE, ~~210~~ 250
NOW ECHOES CAN BE ELIMINATED

All telephone connections exhibit echoes to some extent. They arise at the hybrids that connect the four-wire circuits used in toll links to the two-wire circuits used in exchange - subscriber loops (see Figure 1 below).

Echoes are particularly troublesome in long-haul circuits; the long delay before hearing the returned echo makes it more noticeable and can influence the customer's ability to converse. With satellite links, the problem is particularly severe. A satellite in geostationary orbit introduces a

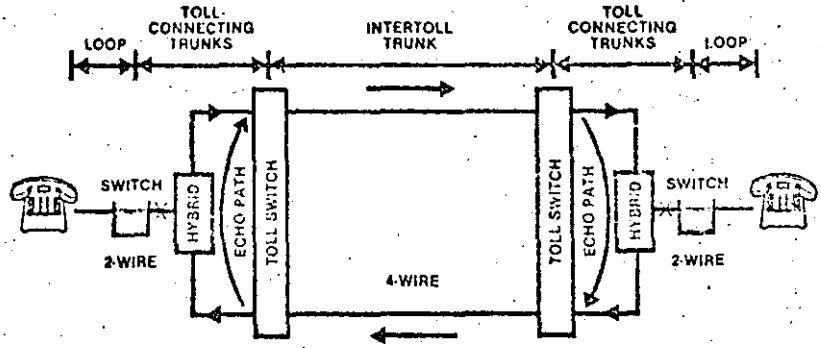
transit delay of about 0.3 second from sender to receiver. If the satellite is used for both directions of transmission (the normal full-hop mode), the round trip delay is 0.6 second. Tests show delay alone is not especially troublesome to subscribers, but the occurrence of echoes with delay causes annoyance.

In the past, telephone engineers have sought to reduce echoes with two principle strategies: loss and suppression. For trunks less than 3,000 kilometers (1,850 miles) long, intentionally adding a bit

of loss-up to 3dB-attenuates the returning echo enough to make it less objectionable. Alternatively, an echo suppressor may be used, which operates by determining which party is talking and inserting a high loss in the return path. However, echo suppressors have two serious failings: they tend to clip the initial parts of words, and they lead to a very distracting "chopping" of the conversation, particularly on satellite circuits, when both parties speak at the same time.

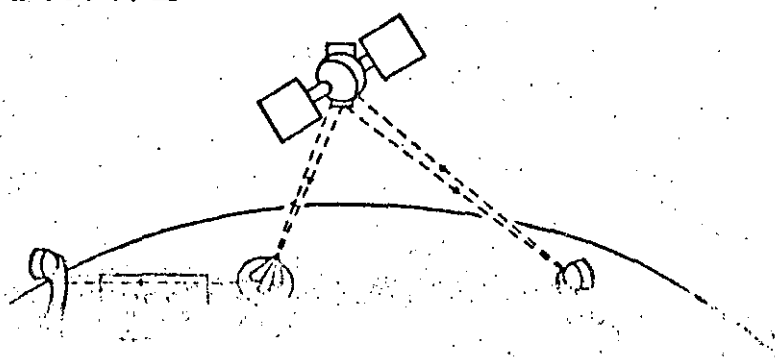
HOW ECHOES ARISE

FIG. 1.
Echoes arise because of impedance mismatches at the two-wire to four-wire hybrid junction of telephone circuits. Some of the incoming signal is reflected as echo back to the sender. Exact shape and magnitude of the echo depends on the circuit established for that particular call, so no fixed impedance can compensate for all calls.



SATELLITE CIRCUITS AGGRAVATE ECHO PERCEPTION

FIG. 2.
Satellite links are much longer than terrestrial links. The resultant delay is not necessarily annoying in itself, but it makes echoes much more noticeable and disturbing.

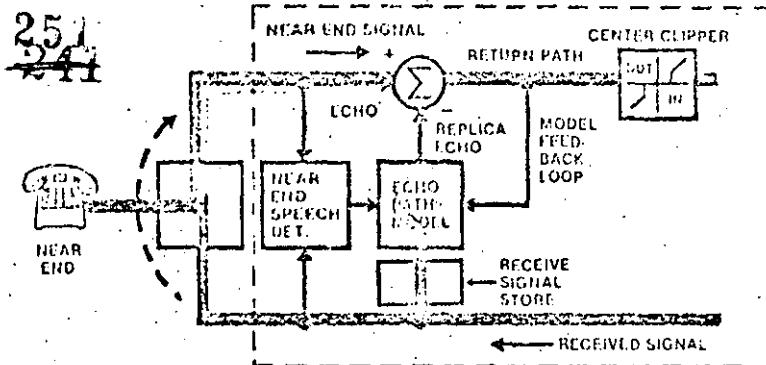


HOW THE NEW ECHO CANCELLERS IMPROVE CIRCUIT PERFORMANCE

Canceling the echo before it returns

FIG. 3. VLSI Chip Inside brown dotted lines.

The echo canceler, installed at toll offices, samples the received signal (shown in dark purple) and creates a replica of the echo that will be generated in the hybrid and two-wire connection to the local subscriber. At the summing junction, the replica echo (shown in light purple) generated by the echo path model is subtracted from the real echo (also shown in light purple) and the signal from the near end (shown in green), effectively canceling only the echo.



Echo cancelers are a vast improvement over echo suppressors of the past. The principle of echo cancellation which was discovered at Bell Laboratories is entirely different from echo suppression. The echo canceler is an adaptive circuit that generates a close replica of the echo, complete with appropriate delays, and subtracts it from the signal in the return path. This substantially cancels the echo, improving communication, but does not introduce any chopping or clipping.

How is the replica of the echo created? Through the use of special adaptive circuits developed by Bell Laboratories and manufactured by Western Electric. At the heart of the echo canceler is a Very Large-Scale Integrated (VLSI) circuit chip (see photo) containing 50 thousand transistors to perform the following functions:

- Convert A or μ -Law encoded speech to linear and floating point

- Store incoming speech signals in a shift register delay
- Approximate the echo path impulse response adaptively
- Automatically weight each of the delayed samples to produce the optimum match to the returned echo
- Sum the outputs of all weighted, delayed samples and subtract that sum from the returning echo
- Detect near end speech and center clip residual echo as necessary

Thus the echo canceler adapts itself to the particular hybrid and two-wire loop used for each conversation. The echo is canceled at the end where it is created. Ideally, echo cancelers should be installed at both ends of the circuit; however, they are compatible to work with echo suppressors which may be in operation at the other end of the circuit.

USERS PREFER ECHO CANCELLATION

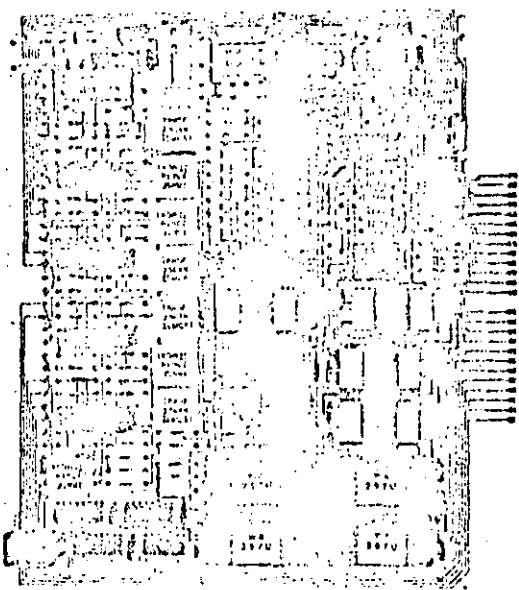
Subjective tests confirm that users prefer echo cancellation to echo suppression—especially on full hop satellite links. More than 60,000 echo cancelers, manufactured by Western Electric, are at work on terrestrial and satellite circuits in toll offices throughout the United States.

COMMUNICATION SYSTEMS WORLDWIDE

The Echo Canceler Product Family is one of the leading edge technological advancements designed by the Bell System. It represents a commitment to providing communication systems worldwide, solving customer problems, and supplying service excellence. For more information on our products and resources, contact your local AT & T International Representative.



THE 4B ECHO CANCELER SYSTEM CREATED FOR WORLDWIDE USAGE



THE 4B ECHO CANCELER
CIRCUIT BOARD

The VLSI canceler used in the 4B Echo Canceler System is a digital device designed to cancel echoes on a single voice circuit. Each echo canceler plug-in board contains the necessary electronics to provide simultaneous echo control for two separate telephone circuits.

Board size is 215 mm deep by 283 mm high. The face plate is equipped with jacks to allow testing of the echo canceler while mounted in the shelf.

Transmission level points may be changed in the field by adjusting the attenuation pads mounted on the circuit board.

A tone-detector circuit is available as an option. The tone disabler is designed to meet CCITT Recommendation G. 164 Section 4.

The convergence speed may be selected to be 25, 50, 100 or 200 dB per second.

External pin-outs to the edge connector are provided for remote enabling/disabling or resetting of the echo canceler by an external ground.

The 4B Echo Canceler System has been designed to meet the needs of communication systems worldwide. It is particularly useful on trunk circuits with long propagation delay, especially satellite circuits. To cancel echoes, it uses principles that were discovered at Bell Laboratories and a custom Very Large-Scale Integrated (VLSI) circuit chip that was developed by Bell Laboratories and manufactured by Western Electric. Echo canceler performance is superior to performance obtained with echo suppressors, as demonstrated in user tests and through continuing customer satisfaction.

The 4B Echo Canceler System can be used worldwide without modification.

The 4B Echo Canceler meets the performance requirements specified in CCITT Recommendation G. 165 - Echo Cancelers. The 4B Echo Canceler System provides a self-contained voice-frequency analog interface and digital echo canceler with 32 msec (nominal) echo tail capability.

A complete 4B Echo Canceler Shelf Assembly consists of a shelf containing echo canceling capability for 24 individual voice-frequency (300- to 3400 Hz) circuits, and a power supply working off -48V office power. The shelves are designed to mount in the proposed CEPT 600 mm x 260 mm x 2100 mm bay and feature front-access for easy cabling and maintenance.

While the echo canceler is mounted in the shelf, analog access to both the transmit and receive ports on both the facility and drop side are provided by four splitting jacks. Thus, if the circuit is busied out for maintenance, commonly available equipment, such as a Return Loss Measuring Set or simply a noise source and a meter, together with an attenuator pad, can be used to test the canceler.

4B ANALOG ECHO CANCELER

253
243

FEATURES

1. 32-msec echo tail capability
2. Selectable Echo Path Return Loss
3. Adjustable convergence rate of canceler
4. External control of echo canceler enabling and resetting
5. Provision for adjusting the analog interface TLPs (Transmission Level Point).
6. 2100-Hz tone disabler
7. Center clipper to remove low level residual echo, equipped with noise matching to eliminate noise modulation
8. Front jack access for local testing

4B ECHO CANCELER SPECIFICATIONS

Echo Path Return Loss (ERL):	0 or 6 dB (selectable)
ERL Enhancement:	> 30 dB
Residual Echo with Center Clipping	< -65 dBm0
Convergence Time:	100 to 800 msec (selectable)
Maximum Impulse Response Length	> 32 msec (nominal)
Transmission Levels:	-8 to +7 TLP receive (selectable) -16 to 0 TLP transmit (selectable)
Insertion Loss:	0 ± 0.3 dB
Frequency Response:	± 0.5 dB (400 to 3000 Hz)
Input/Output Impedances:	600 ohms, balanced
Idle Channel Noise:	< 19 dBBrnc0
Harmonic Distortion:	< 1%
Dynamic Range:	+3 to -60 dBm0
Tone Disablers:	Meets CCITT Recommendation G. 164 Section 4

COMMUNICATION SYSTEMS WORLDWIDE

The 4B Analog Echo Canceler has been designed by the Bell System to meet the needs of communication systems worldwide. It represents the Bell System's commitment to perform at the leading edge of

technological advancement. For more information on the 4B Analog Echo Canceler and our other products, contact your local AT & T International Representative.



AT&T International

254
244

CANCELADOR DE ECO DIGITAL MULTICANAL

244

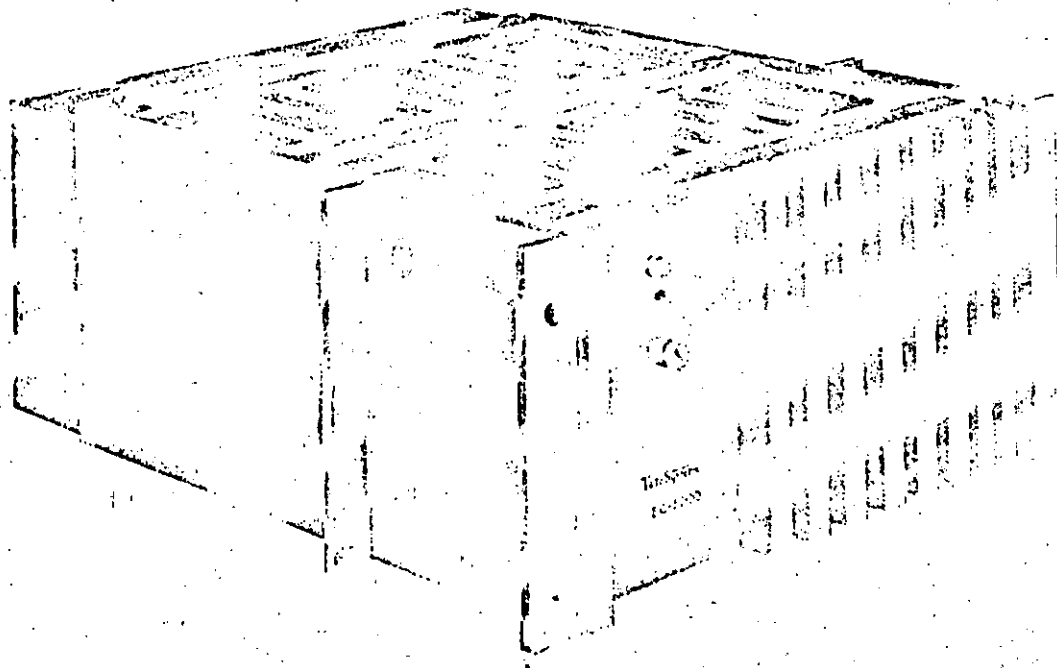
EC-5000, COMSAT GENERAL TELESYSTEMS

COMSAT GENERAL TELESYSTEMS

255

245

**EC-5000
MULTICHANNEL
DIGITAL ECHO
CANCELLER**



The EC-5000 is the latest advancement in echo canceller technology for long distance telephone communications over multichannel digital transmission facilities. Complies with CCITT Recommendation G.165.

A QUANTUM LEAP

COMSAT General TeleSystems' contribution to the development of echo canceller technology, established by our family of single-channel echo cancellers, takes a quantum leap forward with the introduction of the EC-5000 Series Multichannel Digital Echo Canceller.

Designed to be cost-effective, and efficient, the EC-5000 is a stand-alone device that operates in a full duplex 24-voice channel 1.544 Mbps T1 circuit. Each 64 Kbps 8-bit PCM mu-law companded voice channel is assigned an individual echo cancelling processor, which adapts to the tail circuit on a dynamic basis and provides up to 45 db of echo cancellation on any tail circuit with up to 32 msec (1600 miles) delay.

Advanced Digital Design
Complies with CCITT Recommendation G.165

The EC-5000 is a *totally digital device* requiring no adjustments or alignment during installation or operation. *Modular construction* permits easy subassembly replacement for maintenance and optional changes.

The design is based on *low power C-mos* technology and a TeleSystems' proprietary design which includes a *VLSI Chip processor* developed specifically for echo canceller functions.

Full Compatibility

The EC-5000 is compatible with alternate *Voice/Data* service on each of the 24 voice channels (when equipped with TD—tone disabler—option or when the user provides canceller disable signal for individual channels).

The EC-5000 conforms to *North American T1* standards and is directly compatible with D type channel banks such as WECO D1D, D2, D3 or D4; M1C, M12, and M13 Multiplex; T1 Transmux Equipment; and switching equipment which meet DS-1 interface specifications (AT&T Technical Advisory No. 32).

The Unit is *transparent* to T1 and is installed directly into T1 service on the longhaul (four wire) side of a channel bank or digital switch. A/B signaling bit integrity is assured. The EC-5000 inserts 3 PCM frames (375 microseconds) delay into the transmit side and no delay into the receive side of the T1 circuit.

Dynamic Test Routines

TeleSystems' EC-5000 is equipped with dynamic *Self-Test* features which can provide diagnostic tests for each echo canceller automatically when a channel is idle

or when a channel is removed from service.

The unit is also equipped with a *Manual, Automatic and Remote Control and Test* features that can disable any echo canceller and/or subject it to tests without interfering with normal operation of other channels. The control and test functions are generated on the basis of information derived from *Inband Signaling, Front Panel Controls*, or via a signal interface from a local switch or channel bank.

Complete Flexibility

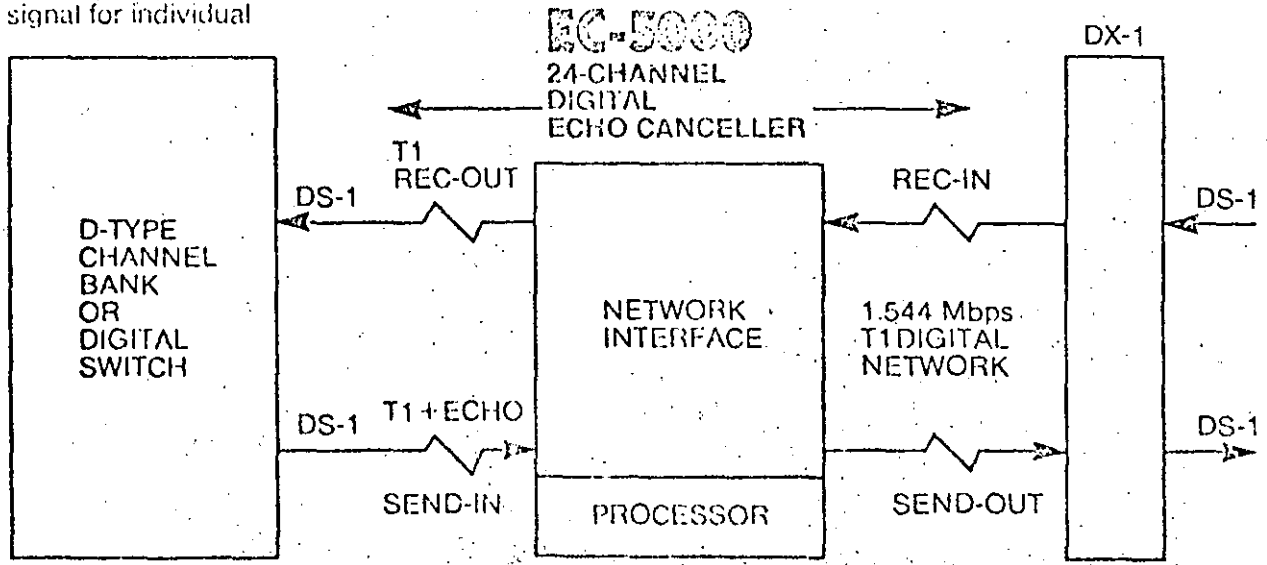
The EC-5000 is designed to operate in a *telephone plant* environment. It mounts into an EIA standard 19" rack, operates from -48 VDC Power Supply, consumes 80 watts at -48 VDC, and requires no forced air-cooling. It complies with general telephone plant engineering practices.

GENERAL DESCRIPTION

The EC-5000 consists of two major functions subsystems: The *Network Interface* and *Processor* (see diagram).

Network Interface functions: receive and send 1.544 Mbps digital bit stream from the longhaul and local circuits; provide synchronization and timing for the entire unit; multiplex and demultiplex T1; signaling bits extraction and insertion; idle channel code detection; test functions and other controls; front panel control interface; service control interface (optional). Provides an elastic buffer allowing for relative clock drifts between transmit and receive paths and frame deletion or repetition to accommodate buffer overflow/underflow caused by cumulative effects of the drift.

Processor functions: digital echo canceller for each of 24 voice channels consisting of tail circuit modeling; echo estimate generation; echo subtraction; double talk detection; center clipper for removal of residual echo; tone disabler (TD) (optional).



SUMMARY SYSTEM SPECIFICATIONS

257

247

Message Format

T1 signal format operating at 1.544 Mbps for 24 64-kbps voice channels with 8-bit mu-law (μ -255) compressed PCM encoding.

Network Interface Specifications

Input Signals (*)

Line rate	1.544 Mbps, ± 200 bps
Line code	AMI, bipolar, return-to-zero
Line impedance	100 Ohms, nominal
Base-to-peak amplitude	1.5V to 3V, $\pm 10\%$
Minimum pulse density	One binary 1 in 16 bits (no more than 15 consecutive zeroes)
Average pulse density	Not less than one binary 1 in 8 bits

Output Signals (*)

Line rate	1.544 Mbps, ± 200 bps
Line code	AMI, bipolar, return-to-zero
Line impedance	100 Ohms, nominal
Base-to-peak amplitude	3V to 6V, $\pm 10\%$
Amplitude unbalance between positive & negative pulses	$\pm 5\%$ of base-to-peak amplitude
Half-amplitude pulse width	324 ns ± 30 ns
Width unbalance between positive & negative pulses	± 15 ns
Rise and fall time (10% to 90% base-to-peak amplitude)	80 ns, maximum
Minimum pulse density	One binary 1 in 16 bits (no more than 15 consecutive zeroes)
Average pulse density	Not less than one binary 1 in 8 bits

* (AT&T Technical Advisory No. 32 and No. 24)

Processor Specifications

(Specification applies to each voice channel)

Echo Return Loss Enhancement (w/ERL of 6 db)

Nominal	45 db
W/Center Clipper disabled	24 db
Rate of convergence	90% in 250 msec
Tail circuit delay capacity	32 msec
Tail circuit length (nominal)	1600 miles
Minimum Echo Return Loss (ERL) requirements	6 db
Tone Disabler (option)	A single 2050 to 2240 Hz tone (Complies with CCITT recommendation G.161.)
Power Requirements	-44 to -56 VDC
Power Consumption	80 watts at -48 VDC (w/TD) 70 watts at -48 VDC (w/o TD)

Physical Specifications

Size	19" rack mount chassis 12.2" (31.72 cm) high 18" (46.80 cm) deep
------	--

SUMMARY SYSTEM SPECIFICATIONS

Environmental Specifications

Temperature (non-operating)

-60°C to +70°C

Temperature (operating)

-10°C to +50°C

Humidity

to 95% non-condensing

Altitude (operating)

Sea level up to 3,000 meters

Altitude (non-operating)

Sea level to 10,000 meters

• Options

117 VAC Power Supply

Redundant Power Supply

TD (Tone Disabler) Option

30 channel CEPT-32 compatible
service at 2.048 Mbps

A Word About COMSAT General TeleSystems

Dedicated to the engineering of state-of-the-art equipment to meet today's needs, COMSAT General TeleSystems is engaged in the manufacture of specialized high technology products for the telecommunications industry.

For More Information

... about COMSAT General TeleSystems or the EC-5000 Multichannel Digital Echo Canceller, write or call today. The number is (703) 698-4300. Telex 901-137.

TeleSystems COMSAT GENERAL
A COMSAT COMPANY

2721 Prosperity Avenue
Fairfax, Virginia 22031

PRUEBAS SUBJETIVAS DE CANCELACION DE ECO REALIZADAS

POR INTELSAT

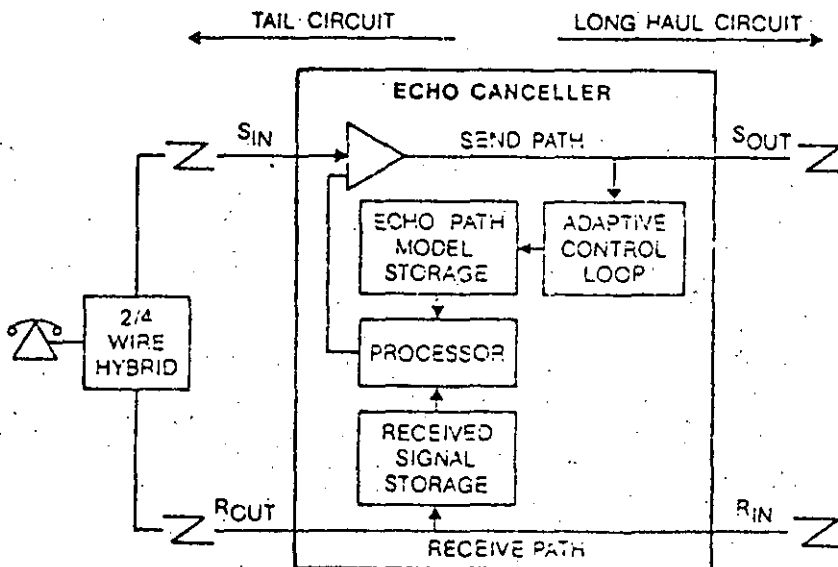
249

ECHO CONTROL

The following packet of information concerning echo cancellation has been assembled as an aid to those interested in the subject.

INTELSAT has sponsored various programs to study methods of improving echo control. The other articles include customer opinions, CCITT Standards and Comparative Evaluations conducted in Canada and within AT & T.

For further information please feel free to contact our Marketing Department.



(INTELSAT RESEARCH AND DEVELOPMENT PROGRAM -- TEN YEARS OF PROGRESS - 1980)

251

"The increased propagation time involved in satellite transmissions precipitated a reexamination of the well-known telephone echo problem. Since echo control is a crucial factor in satellite circuits, over the past 10 years INTELSAT has sponsored an intensive program to study methods of improving echo control on satellite circuits."

* * *

"Until recently, echo suppressors have been exclusively employed to control echo. However, the use of echo suppressors, even those of modern design, creates some annoying side effects, which decrease with increasing echo return loss."

* * *

"Recognizing the inherent limitations of echo suppressors, INTELSAT sponsored a program for studying the feasibility of echo cancellation, a technique which promises to eliminate echo-related problems from satellite communications...Echo cancellers were successfully tested between four pairs of INTELSAT countries on satellite circuits spanning the Atlantic and Pacific Oceans.

* * *

"Because of echo cancellation, satellite transmissions equal high-quality terrestrial communications... as illustrated by the data shown in Figure 41, based on an American Telephone & Telegraph (U.S.) report. The present effort under INTELSAT...is receiving wide interest from manufacturers.

* * *

"The echo control project has...brought about the realization of echo cancellers for satellite communications, eliminating the difference in quality between satellite and terrestrial communications which the echo suppressor is unable to achieve."

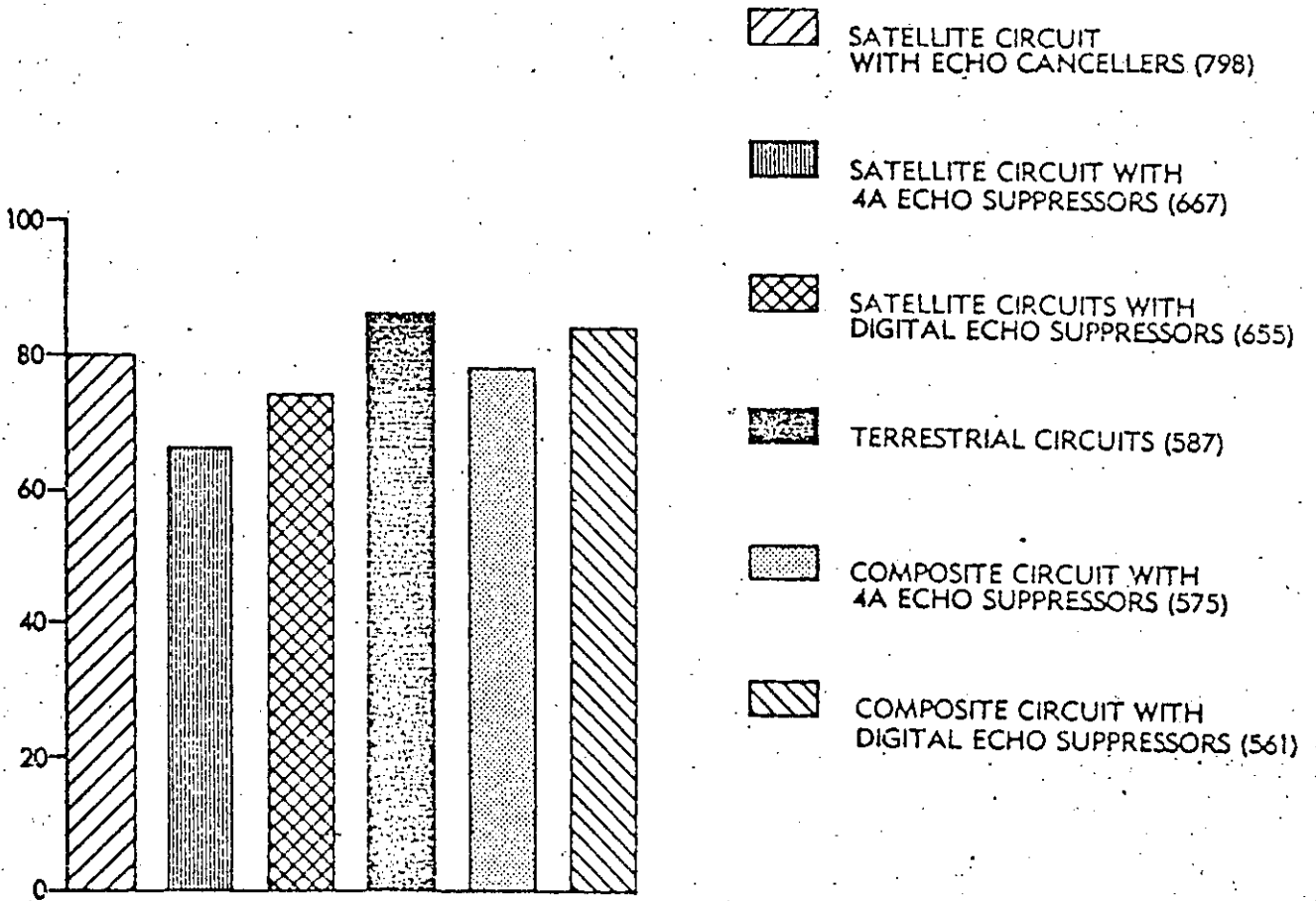


Figure 41. Results of Customer Rating Calls "Good" or "Excellent"

INTELSAT Field Test Trials

263

253

ESTUDIO COMPARATIVO DE 253

SUPRESORES Y CANCELADORES

DE ECO

(RCA)

R. Setzer

264

254

Echo control for RCA Americom satellite channels

Satellite telephone service has been plagued by the echo problem since its inception. The echo canceller has come close to eliminating the problem once and for all — and RCA Americom is leading in the application of this device to its private line circuits.

Introduction

The introduction of satellites as a transmission facility for voice communications has added a new dimension to the problem of echo control in telephone circuits. Formerly, long line terrestrial transmission links used devices which were designed to provide an acceptable level of telephone circuit noise and echo for 99 percent of the population. However, the satellite link has rendered these devices unsatisfactory for a high percentage of the population, even when appropriate changes were made for the long delay of the satellite link. Therefore, objectionable results were obtained from early satellite telephone circuits because of the application of an outdated echo control technology. In fact, it has been determined from surveys that over 85 percent of potential satellite voice circuit users have been reluctant to use them because of the echo control problem. In the early 1970s, technological programs were introduced to solve the problem.

RCA Americom has been working jointly with industry to advance the state of the art, and currently is leading in the application of the latest device, called an echo canceller, to its private line circuits. The echo canceller will finally come very close to eliminating the echo problem once and for all.

The following article reviews the circuit parameters that cause echo and discusses

Abstract: *The fundamental problems caused by echo on telephone plant circuits and the circuit parameters are outlined. How these problems are solved and the efficiency of the solution is of major importance. The need for echo control on satellite channels is defined and two*

methods of control are discussed and compared: echo suppressors and echo cancellers. The basic principles of echo suppressors are outlined. The conditions that cause the need for echo cancellers and how echo cancellers successfully solve the echo problem are also described.

the operation of the echo suppressor and echo canceller in satellite telephony.

Fundamentals

An echo can be defined as a reflection of electric or acoustic energy. In many applications, reflection of electromagnetic waves is desirable, such as in radar or troposcopic communications, but reflection of speech is generally undesirable. Reflections occur at irregularities of transmission mediums and this is also true of telephone communication systems.

To determine the historical cause of communication circuit irregularities, it is interesting to reconstruct the development of the equipment leading to the present telephone plant. Consider first the telephone instrument itself. Naturally, a microphone is required to convert the speech to electrical energy and a speaker converts the electrical energy to acoustic energy. These devices each normally require a pair of leads.

Next, considering the objective of interconnecting subscribers great distances apart, it would be desirable to carry both the transmitted and received signals on the same pair of wires. This is indeed possible by using a simple transformer incorporated into the telephone set as shown in Fig. 1. Transmitter currents flow in opposite directions through windings A and B and cancel each other's effect in winding C to the same degree that impedances Z_{BAL} and Z_o match each other. These impedances are intentionally different so that a voltage is induced in winding C (called sidetone) and makes the instrument sound "alive". Also, received signals from the central office flow through windings A and B in series and provide the receive audio. The components providing this 2-wire to 4-wire signal separating function have come to be called the terminating set, or "term set."

Next, consider the interconnection of telephone sets which are carried on a 2-wire

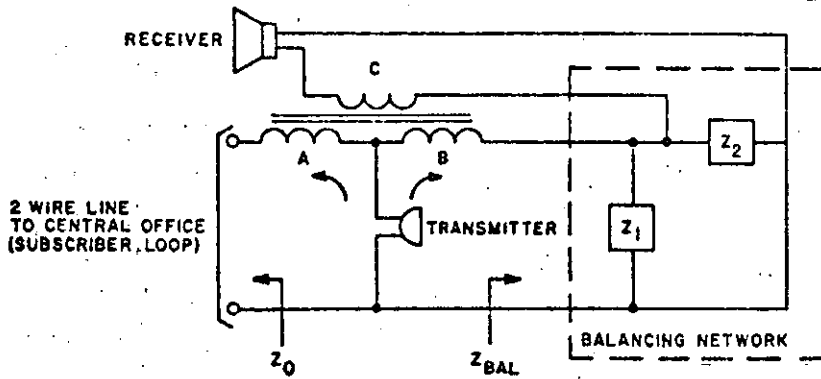


Fig. 1. The transformer in the typical telephone set permits the same pair of wires to carry both the transmitted and received signals.

basis to a switching office and then transmitted on a carrier facility (4-wire basis by nature) where many channels are multiplexed together. This is shown in Fig. 2. Note that the telephone set is shown as a 2-wire device but actually contains an integral term set. A term set is also required at each central office to separate the directions of transmission; but these term sets should be balanced as much as possible to accept the 4-wire receive (RX) from subscriber A, for example, at central office B and transmit it to the 2-wire facility toward subscriber B. This is shown as the direct speech path in Fig. 2. Leakage at the distant end from the 4-wire receive (RX) to the 4-wire transmit (TX) provides an undesirable echo path. The amount of leakage is called return loss (also echo return loss, or ERL) and can be expressed in decibels as:

$$ERL = 20 \log_{10} \left| \frac{Z_{BAL} + Z_{sub}}{Z_{BAL} - Z_{sub}} \right| \text{ dB}$$

Z_{sub} is determined primarily from the constants of the cable transmission line since the impedance of the telephone set can be controlled and the switching office is designed to provide negligible impedance transformation. However, each subscriber varies in distance from the central office and this causes a tremendous variation in Z_{sub} . Impedance compensation for each subscriber line is almost as economically prohibitive as providing 4-wire transmission for each line.

Z_{BAL} is selectable by circuit design but only a compromise value can be chosen to match the average value of Z_{sub} . The wide statistical variation in Z_{sub} is nevertheless well known and results in a distribution of ERL that has been shown to have a normal

probability density function. The distribution of subscriber loop impedance can be approximated by a normal probability density function, as shown in Fig. 3, but the approximation is not generally used. In any event, an average value of Z_{sub} has been historically chosen as the "average subscriber loop."

Thus,

$$Z_{BAL} = \text{Average} [Z_{sub}] = R + jX_c,$$

where $R = 900$ ohms, $C = 2.16 \mu F$.

Studies of the subjective reaction to echo over the range of expected ERL values have shown that the quality of the connection degrades as the echo is delayed in time. For short delays, the echo appears as additional sidetone and is no problem. For longer delays the same amount of echo is more objectionable and finally becomes intolerable. However, within limitations, it is possible to introduce direct loss in each direction of transmission to reduce the echo to an acceptable level. This loss should be introduced as a function of propagation delay (distance). The direct speech signal suffers the loss once but the echo path includes the loss twice.

This technique of introducing loss as a function of distance has been called the Via Net Loss plan (VNL)¹ and has been the basis of the Bell System terrestrial network design. Figure 4 shows the amount of loss required. Above 45 msec, the loss is excessive and an echo suppressor is required. Since the round trip delay of a satellite channel is approximately 600 msec, all satellite channels are equipped with echo suppressors.

Echo suppressors — how they work

The basic operating principle of an echo suppressor is to provide a direct speech path under some conditions and to interrupt the echo path under others. Note that the direct speech path used when one subscriber is talking becomes the echo path when the other subscriber is talking, as shown in Fig. 5. This is a split-type echo suppressor where one device is provided at each end. When only one person is talking, B, for example, B's TX PAD is set to 0 dB as is A's RX PAD. Therefore, no loss is encountered from B to A. Also A's TX PAD is set to 50 dB to prevent B from hearing his own echo, but this is no problem since A is not talking anyway. The circuit is symmetrical for single talker conversation in the reverse direction.

The problem is what to do when both parties talk at the same time. The design shown in Fig. 5 detects this double-talking condition and each suppressor switches in a 6 dB pad in the receive direction. (Actually the suppressor of the active speaker had switched in its 6 dB pad in anticipation of this state). These pads attenuate the direct speech of each talker by 6 dB and, as shown in the previous section, reduce the talker echo by 12 dB. The values chosen evidently represent a compromise. Also, the ERL distribution of 1103 dB (meaning normal

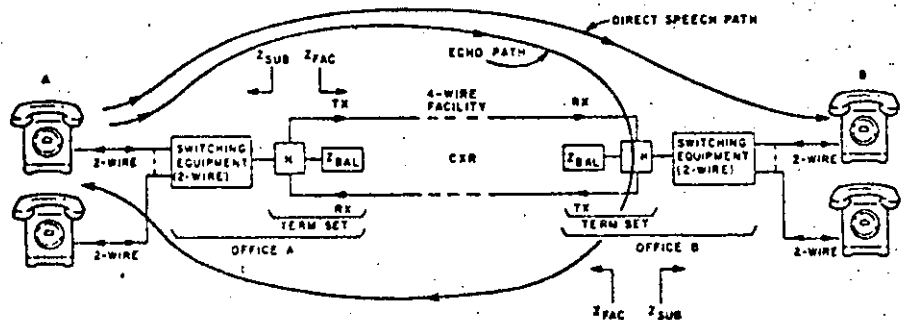


Fig. 2. Illustrating the use of "term sets" at each central office to provide 4-wire capability.

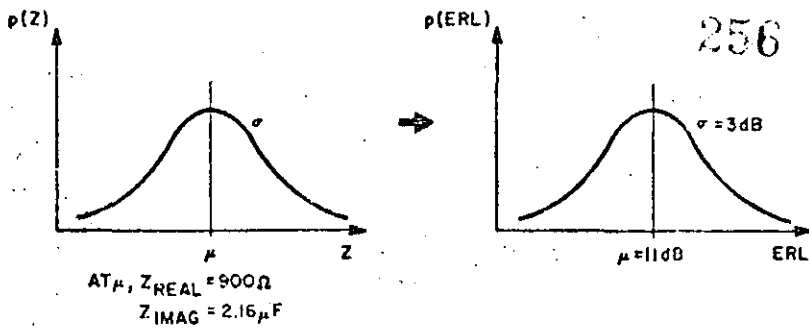


Fig. 3. Probability density functions of subscriber loop impedance and echo return loss.

distribution with mean of 11 dB and standard deviation of 3dB) is added to 12 dB to provide the overall level of echo protection. This approach does not satisfy VNL rules for echo protection but this is only true for the double-talk state.

Suppression loss hangover time

To gain further insight into echo suppressor operation, consider one of the timings involved in switching these pads in and out. The round-trip delay of the terrestrial link from the echo suppressor output through the hybrid and back to the echo suppressor input is called the echo path delay. This delay is a function of distance and, for domestic satellite circuits with both ends in the same country, the terrestrial delay typically ranges 0-30 msec. Now, consider a graceful transition from a single-talker state with A talking to a single-talker state with subscriber B talking, with a quiet interval in between. When A is talking, B's transmit pad is set to 50 dB but when A stops talking, B's pad should remain in the circuit for the echo path delay. The timing involved in holding the transmit pad (suppression pad) in the circuit for the round-trip terrestrial delay is called the suppression loss hangover time and is typically set to 60 msec (for worst case echo path delay). For B's transmit pad to suppress all of A's echo by 50 dB, the quiet interval must be at least:

- one-way terrestrial delay (15 msec) for A, plus
- one-way satellite delay (300 msec), plus
- round-trip terrestrial delay (30 msec) for B.

In other words, all echo can be sup-

pressed by 50 dB if the conversation is not more interactive than 345 msec. However, this is not likely and if B interrupts before this critical interval has expired, the suppression pad must be switched in to carry B's signal, and A's echo is returned (the suppressor loss hangover protection is lost).

The performance becomes even worse when one considers the detection threshold of the double-talker detectors of Fig. 5. Recall that the ERL distribution of the terrestrial link is 11±3 dB. Using the 2σ low as the minimum ERL to be encountered, 5 dB can be expected. Now, the echo suppressor must be designed so that a constant echo of 5 dB does not create a double-talker or break-in condition, otherwise the unit would always be in double-talk and the performance would be very poor. Therefore, voice levels must be closer than 5 dB to cause break-in, and a comparative difference of +1.5 dB has been selected.

However, the following variations can be listed in the voice levels applied to the echo suppressor:

1. zero to seven decibel variation in subscriber loop losses,
2. zero to three decibel variation in carrier and cable gain stability,²
3. talker volume distribution with $\mu = -15$ dBm, $\sigma = 5.8$ dB.³

Therefore, variations on the order of 10 dB in average voice levels can be expected, but the echo suppressor cannot break-in until voice levels are within 1.5 dB. As a result, speech bursts can be lost entirely. More commonly, speech chopping results. This problem can be called the "equal-level break-in problem."

These echo suppressor impairments and others have been studied for 40 years⁴ and, while substantial improvements have been made, the basic impairments still remain

today for channels equipped with echo suppressors. A new technique is desirable and is now available with the echo canceller.

The echo canceller

To take a fresh look at the problem, let us list some of the known conditions.

1. An echo signal will be returned, with expected loss of 11±3 dB (depends on impedance of 2-wire section).
2. The echo will be delayed in time, with expected delay of 0-30 msec (depends on length of 4-wire terrestrial section).
3. The signal which will become the echo is available in time before the actual echo is generated.

Therefore, if the signal which will become the echo is stored and the terrestrial level and delay are somehow determined, an estimate could be made of the expected echo. This estimate can then be subtracted from the actual circuit echo when it occurs. Furthermore, the estimate can be updated to further reduce the actual echo. A block diagram of such a circuit is shown in Fig. 6 and is called an echo canceller. This concept was basically developed by Comsat Labs.

The echo canceller, under a single talk condition, samples and stores the voice signal present at the satellite receive (SAT. RX) input and uses this as the first estimate of the echo (perhaps reduced by 11 dB). When the actual echo is received at the terrestrial transmit (TERR. TX), the es-

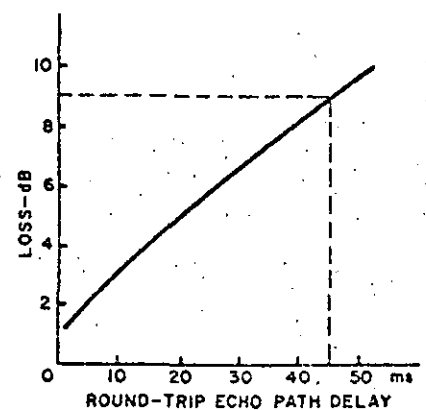


Fig. 4. The amount of loss required to reduce echo level increases with echo path delay.

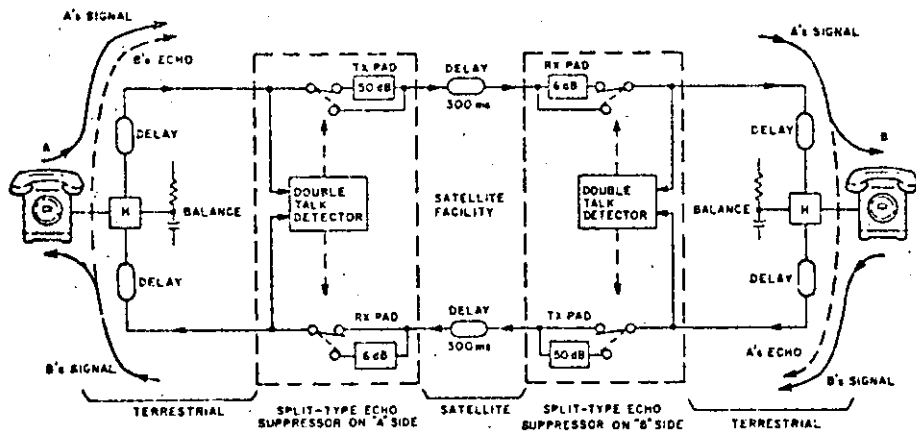


Fig. 5. A split echo suppressor connects the transmit speech path when one subscriber is talking but disconnects it when the other subscriber is talking (since this path is now the undesirable echo path)."

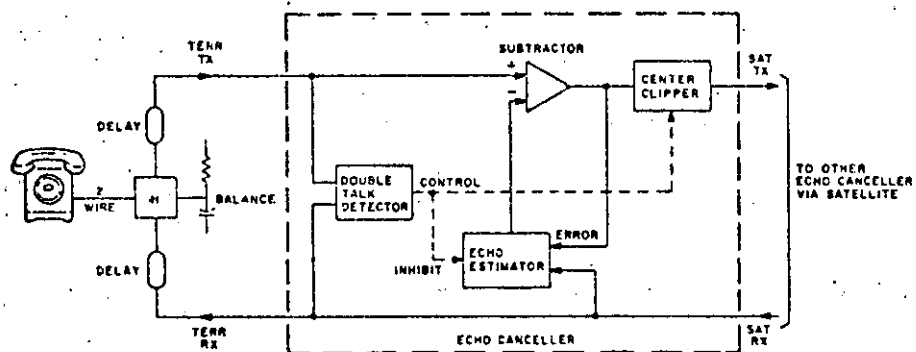


Fig. 6. The echo canceller estimates the expected echo level, then subtracts the estimate from the actual circuit echo when it occurs.

imate is subtracted from it and an error signal is generated. The error signal updates the echo estimate to reduce the error to a minimum. This process is called convergence, and generates a model of the echo path.⁶

Estimating the echo

The accuracy of the echo estimate, and thus the degree of cancellation is determined from several things. First, the actual error signal is contaminated with terrestrial noise. The echo canceller converges on the echo signal and also attempts to converge on the noise which continually changes the echo estimate to a small degree. Also, the structure of sampling, storing and correlating the actual and estimated echo signals limits the amount of resolution. Finally, the step size used in adjusting the echo estimate affects the residual echo left after cancellation, and results in an interesting tradeoff.⁵ If the step size is large, the speed of convergence will be fast but the

resolution will be limited. If the step size is small, convergence will be slower but the degree of cancellation will be better.

Considering these variables, the raw subtraction process is limited to about 30 dB of echo cancellation, with convergence in approximately 250 msec. It is desirable to achieve even further echo cancellation, for the single talker state, on the order of 45-50 dB. This is accomplished by removing all signals below a certain threshold, in the residual echo path (after subtraction). Signals above the threshold are not appreciably affected. This operation is called center clipping, and is also shown in Fig. 6. The center clipper rejects small signals (i.e., residual echo not cancelled by the subtractor plus terrestrial noise) but passes large signals (i.e., direct speech). The center clipper of an echo canceller is comparable to the suppression pad of an echo suppressor. In fact, an echo suppressor can be considered to be a center clipper with a very high threshold⁵; but it rejects all signals, wanted or unwanted.

The beauty of the echo canceller techni-

que is apparent during the double talk condition. Assuming that a period of single talking has occurred, the echo canceller will have converged on the line characteristics. Approximately 45 dB of echo cancellation is achieved after 250 msec with the center clipper "in" the circuit. Now, when double talk begins, the echo canceller must not be allowed to operate on the local signal and echo at the same time since this will adversely affect the echo estimate. The local direct speech signal would give a tremendous error in the echo estimate since it is not related to the distant signal. Therefore, the echo estimator must be inhibited from updating on the error signal as soon as double talk is detected. However, the echo estimator still maintains an accurate model of the echo path and continues to subtract the echo. The only possible problem occurs if the line characteristics change during the period of double talking but this is not very likely. Also, the center clipper is switched "out" of the circuit since it serves no useful function at this time and would only distort the near-end speech. Therefore, continuous double talking is possible with echo cancellation of 30 dB at each end. No speech bursts are lost since the process is continuous.

The processes involved in echo cancellation lend themselves to microprocessor control. First, the speech signal destined to become the unwanted echo signal must be sampled and stored for the maximum roundtrip terrestrial delay. For sampling at the Nyquist rate of $1/2f_{max}$ ($= 125 \mu\text{sec}$) and storing for 30 msec, 240 samples are required. Using a 12-bit speech sample and a 9-bit representation of the line impulse response, a minimum mean-square error algorithm used to converge the canceller would require 250 multiplications of 12 by 9 bits and 250 additions of these products during every sampling period. Another Comsat design⁷ uses logarithmic encoding to reduce hardware and calculation complexity and saves 28 percent of the memory space required for the previous Comsat design.⁶

Comparison of performance and conclusion

The quality of a satellite channel equipped with an echo suppressor is a function of many variables. In some cases, the quality is excellent and no practical improvement is possible with an echo canceller.⁸

For example, the performance of the

Table 1. Performance ratings of circuits using echo suppressors and prototype echo cancellers, all operating under the same conditions (for domestic circuits).

Type of circuit	Percentage of calls rated fair and poor
Terrestrial with echo suppressor	10
Composite with echo suppressor	21
Satellite with echo suppressor	34
Satellite with echo cancellor	12

channel equipped with an echo suppressor would no doubt be rated excellent if the following conditions exist:

1. the circuit ERL is 17 dB or greater (2 σ high of 11 σ 3 dB distribution);
2. the terrestrial links exhibit little variation; and
3. the users adjust their talker volumes to overcome the "equal level break-in" problem and subconsciously limit the interactivity of the conversation (become "polite").

However, as these variables deteriorate, so does the performance. The echo canceller, on the other hand, exhibits a more uniform range of excellent performance over the same range of variables. Some results of a comparison between echo suppressors and prototype echo cancellers operating under the same conditions (for domestic circuits) are given in Table I and include composite circuits (terrestrial channel in one direction and satellite channel in the other direction). Composite circuits have slightly more than one-half the roundtrip delay of a full satellite channel and thus would require less reduction of echo signals than a full satellite channel, for the same level of performance.

Thus the echo canceller makes the satellite channel perform as well as a terrestrial channel. Prototype Comsat Laboratories echo cancellers were used in this test.

RCA Laboratories also conducted comparative tests of echo cancellers and echo suppressors. Their results confirm the excellent performance of echo cancellers under a wide variety of circuit conditions. Then, RCA Americom field-tested several units on demonstration and customer

channels and the performance was well received by the customers.

As a result, RCA Americom is intending to apply echo cancellers on a large scale. This improved channel quality will assist RCA Americom in maintaining a strong market share of the private leased channel business.

References

1. "Notes on Distance Dialing," 1975 Edition, published at AT&T.
2. "Data Communications Using Voiceband Private Line Channels," Bell System Technical Reference, PUB 41004.
3. *Transmission Systems for Communications*, Bell Telephone Laboratories, Revised Fourth Ed., Chapter 9 (1971).
4. Brady, P.T., Helder, G.K., "Echo Suppressor Design in Telephone Communications," *Bell System Technical Journal*, Vol. 42 (1963).
5. Weinstein, Stephen, B., "Echo Cancellation in the Telephone Network," *IEEE Communications Society Magazine*.
6. Campanella, S.J., Suyderaud, H.G., Onufry, M., "Analysis of an Adaptive Impulse Response Echo Canceller," *Comsat Technical Review* (Spring 1972).
7. Horna, O.A., Dr., "Echo Canceller with Adaptive Transversal Filter Utilizing Pseudo-Logarithmic Coding," Comsat Laboratories.
8. Suyderaud, H.G., Campanella, S.J., Onufry, M., "Results and Analysis of a Worldwide Echo Canceller Field Trial," *Comsat Technical Review* (Fall 1975).
9. Helder, G.K., Lopiparo, P.C., "Improving Transmission of Domestic Satellite Circuits," *Bell Laboratories Record* (Sept 1977).

Russ Setzer is a senior member of the engineering staff, and as a member of the advanced technology group he is engaged in research and development of satellite echo control and compandor programs.

Contact him at:
RCA Americom
Piscataway, N.J.
Ext. 4224



Data broadcast to microterminals via satellite using spread-spectrum techniques

E. MELROSE

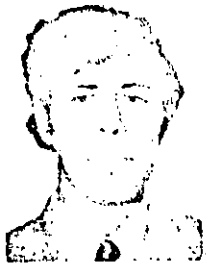
IBI, Intergovernmental Bureau for Informatics, Rome, Italy

A. VERNUCCI

Telespazio S.p.A., Rome, Italy

An experimental demonstration of data base distribution to microterminals via satellite is shortly going to be carried out using an Intelsat V-series satellite, in preparation for the implementation of a fully operational data distribution system (IBINET). This paper describes the techniques used, the applications envisaged, and the configuration of the experiment.

Keywords: Selective data broadcast, spread-spectrum technique



Enrique Melrose graduated from the National Polytechnical Institute of Mexico as an electronic engineer. He earned a degree as "Ingenieur automatique" from the Polytechnical Institute of Grenoble, France, where he also obtained a doctorate in sciences and worked on digital differential analysers (dda) for inertial navigation and numerical control.

He has been Director of the National Computing Center of Mexico and Director General of Planning in the Mexican Ministry of Communications and Transport, where he was responsible for formulating a national medium-term plan for transport and for coordinating a development plan for the communications sector, which included postal, telegraph and telecommunications services.

Since 1978, he has been an officer in the Intergovernmental Bureau for Informatics (IBI) with Headquarters in Rome. He served as Cabinet Director to the Director General and was in charge of programming the organization's activities.

At the present time, he is director of the IBI Technology Department.

1. Foreword

The large-scale miniaturisation of electronic components, and the appearance of increasingly more reliable, faster and cheap microprocessors and data storage devices, are fundamentally changing the classical concepts of informatics, enabling larger data banks to be created, more resource and data processing to be shared, and applications extended into more fields of human activity.

At the same time, telecommunications has adopted similar techniques for handling and carrying signals and information, creating a symbiosis in the form of telematics networks, which may enable the remote user, whether he is an informatics specialist or not, to have possible access to a multitude of data banks or to receive, through the network, the software and data-processing potential for solving his particular problems.

The political impact of this evolution is reflected in the fact that, for evident reasons of precedence and economies of scale, nearly all the large data banks have been created, and are being operated, by industrialised nations, and the real access possibilities to such banks and their practical use by developing countries are becoming more difficult, particularly due to their lack of proper informatics and telecommunications infrastructures. The Intergovernmental Bureau for Infor-

Antonio Vernucci graduated from the University of Rome, Italy as an electronic engineer. He has been with Telespazio s.p.a. since 1974. He participated in several Telespazio projects including the experimentation over the European Orbital Test Satellite (OTS). For three years he was involved in the definition of the time-division access system, which is going to be used by Intelsat and Eutelsat on operational basis. He is presently responsible for the definition of the ss-tdma system to be used over the multibeam regenerative 20/30 Intelsat payload.

North-Holland

Space Communication and Broadcasting 1 (1983) 211-218

matics (IBI) is an international organisation located in Rome with some 36 Member States—many of them developing countries—concerned with a number of coordination and development activities in the informatics field.

The constant effort by IBI to provide all its Member States with assistance for their national programmes of informatics development has motivated a feasibility study ("IBI International Data Network - IBINET", May 10, 1982) whose general objectives were: to analyse the technical possibilities of a data network that could provide all the advantages of value added networks; to give its Member Countries the possibility of hands-on evaluation; and to analyse the regulations, as well as the social and technical implications of advanced information networks. Considering the technological opportunity and the role of IBI, it was concluded that the implementation of IBINET, using the latest technology available, was very desirable in the short-term.

2. Technological options

IBINET is conceived to distribute data bases to microcomputers (or minicomputers) at a large number of widely dispersed remote sites, while retaining central data base control; in other words, it could perform a selective broadcast of data banks or messages.

Before starting the feasibility study on IBINET, certain general guidelines were established for choosing the possible technologies and systems. The low cost, a high reliability and the easy installation of the equipment along with the possibility for the local specialists to actively participate in implementing and developing their own network, based on IBINET, feature among the most important of these guidelines.

Since developing countries are generally characterised by a heavy urban concentration in one or two cities and a marked dispersion of their population over the rest of their territory, it is already possible to consider satellites as a solution. This is all the more true since most of these countries do not even have a sufficiently developed terrestrial telecommunications infrastructure.

However, experience in the cost of other similar projects which have been analysed has also indicated that it is necessary to formulate a different concept of networks involving advanced technologies.

In the first place, there is the natural imbalance in the direction of the information flow in a network, in the particular situation of consulting a remote data base, the amount of query information is much less than the information actually received.

The possibility, therefore, of establishing a network via satellite with highly reliable receive-only stations, and complemented by traditional transmission system for the query return link, appeared to be appropriate in the design of IBINET. Bearing in mind this concept, a large variety of informatics terminals could be connected to an earth station, ranging from a monitor, a micro-computer (intelligent terminal) to a mini-computer which can locally store the information received and provide local off-line services for information retrieval.

IBINET consists of three different elements: the receive-only earth stations, a satellite space segment, and the up-link at the broadcast sites.

The conditions imposed by the low cost (approx. \$2500) of the receive-only earth stations and the ease of installing them, dictated an antenna size substantially smaller than the 3 to 11 meter reflector normally associated with satellite receiver stations in the 3.7 to 4.2 GHz band.

However, small ('microterminal') antennas of 0.6–0.8 meter diameter pose two technical problems: firstly, the low gain of the antenna demands a better signal/noise ratio in the input amplifier and secondly, by reducing the antenna dimensions, the beamwidth is increased and also therefore the interference possibilities with signals from other satellites as well as from terrestrial signals.

Bearing in mind these aspects, the IBINET feasibility study recommends using the spread-spectrum signal-processing technique.

3. The spread-spectrum technique

Spread-spectrum is a transmission modulation technique that has long been used in radio astron-

only research and military communications applications. The technique has been in regular use in commercial data communications networks only since 1981.

Spread-spectrum is particularly suitable for communications via satellite to small earth stations because it permits reliable data transmission despite the presence of strong interfering signals. This technique has been used in military applications to transmit unobtrusive signals that ensure reliable transmission despite 'jamming' signals deliberately transmitted to create interference. Radio astronomy and other space research applications of spread spectrum have permitted reliable communications over interplanetary distances with very weak signals that would otherwise have been overwhelmed by random noise.

As the name implies, more frequency bandwidth is required for spread-spectrum signals than for conventional narrowband signals transmitting comparable data rates. Consequently, the technique has not been extensively used in commercial terrestrial communications applications, where conservation of bandwidth is an important network criterion. In satellite communications applications involving small earth stations, networks are mainly limited by the availability of satellite power rather than by availability of bandwidth. Therefore a limited penalty results from spreading the signal over a greater bandwidth that may otherwise go unused.

But, although antenna design is becoming simpler, the factor that contributes most to the low cost of the earth stations is the adoption of digital electronic signal processing techniques.

The use of microprocessor for monitoring signal acquisition, for effecting the demodulation function, for detecting and correcting transmission errors, and as intelligent interface adaptors, ensures the operating reliability of the stations, eliminates the need for modems and increases the network's flexibility.

The basic principles of spread-spectrum techniques are described below.

Spread-spectrum modulation produces a signal whose bandwidth is much wider than the information bandwidth. A carrier is modulated with information to produce a modulated signal which is

then linearly multiplied by some function of time $F(t)$, such as to spread the energy of the signal over a bandwidth considerably greater than the bandwidth of the original modulated signal. The resulting signal is up-converted to RF and transmitted to the satellite. At the receive side, the above signal results to be linearly combined with other signals, i.e. noise or information coming from other transmitting terminals. All signals have the same nominal carrier frequency. This composite signal is now applied to the input of a receiver, whose job is to extract the original signal and reject all others. To do this, the composite signal is multiplied by an exact replica of $F(t)$. If $F(t)$ is chosen properly, then each receiver is able to extract its own signal and reject all others. Normally $F(t)$ is a high-speed pseudo-random digital stream.

The wideband input signal to the receive consists of the wanted and unwanted signals, each spread by its own code and each having a spectrum of the form $\sin^2 x/x^2$. Receiver thermal noise is also present; it has a flat distribution across the band of interest. This combined signal is applied to the input of unit termed 'correlator', which multiplies the incoming signal by an exact replica of the code $F(t)$ associated with the wanted signal. Thus, the high-speed phase reversals due to the spreading code on the wanted signal will be removed and the original carrier restored. This narrow-band restored signal can flow through a band-pass filter designed to pass only the baseband modulated carrier. As the unwanted signals are uncorrelated with the local code, each signal will appear at the output of the correlator still spread, as a result of the modulo-2 sum of the local code and the unwanted code. If these pairs of codes are uncorrelated, then the power spectra of the unwanted signals before and after correlation will be essentially unchanged. The spectrum of the receiver thermal noise will also be essentially unchanged. Only that portion of the spectrum of the unwanted signal falling in the IF bandwidth of the receiver will cause interference to the wanted signal. It should be noted that any 'unspread' or CW type interfering signal appearing at the input to a spread spectrum receiver will be 'spread' by the local code and will be rejected.

According to the previous discussion, it is clear that the auto-correlation and cross-correlation properties of the set of functions $F(t)$ used at the various transmitting terminals are important in determining the performance of a spread-spectrum system.

The method of generating the binary pseudo-random sequence is by means of a shift register. It consists of a shift register working in conjunction with appropriate logic, which feeds back a logic combination of the state of two or more of its stages to its input. The output of a sequence generator or the contents of its n stages at any sample time is a function of the outputs of the stages fed back at the preceding sample time.

The use of spread-spectrum in the IBINET system has two purposes. The most important is that it spreads the 9600 bps signal over a 5 MHz bandwidth. This spreading is implemented by encoding the modulated signal with a 2.4576 Mbps pseudo-random PSK data stream. This allows a high satellite EIRP to be transmitted without exceeding the flux density limitations set by CCIR to protect ground microwave networks. The 5 MHz signal received by the ground station is well below the receiver noise level; the processing gain restores the 9600 bps data rate to the desired value. The second purpose is to protect the small receiving stations from nearby interference sources.

A satellite data broadcasting network based upon this technique is already operational in the United States. The system employs small receive-only earth terminals (0.6 to 1.2 m diameter). More than 2000 such small terminals are presently being used.

The spreading technique used in this system involves direct biphase modulation. Two orthogonal code patterns '1' pattern and '0' pattern are used as spreading codes. Binary data information is combined with the spreading code by modulo 2 addition, where binary '0' is added with '0' pattern and binary '1' is added with '1' pattern. The resulting binary waveform is applied to a modulator and modulated onto a carrier as phase-reversed-keying. This spreads the signal energy over bandwidth roughly equal to twice the bit rate of the code to produce a noise-like spectrum.

At the receiver, after normal down-converting

to a suitable IF frequency, the received signal is multiplied with a carrier at IF frequency, BPSK modulated by an exact replica of the spreading code used at the transmit side. The effect of this on the receiver is to completely remove the effect of the phase-reversed spreading code. Code synchronization is necessary in the receiver. There are two operations to be performed in establishing synchronization; coarse synchronization and fine synchronization. The simplest method of obtaining coarse synchronization is to adjust the rate of generation of the PN code in the demodulator and serially searching the uncertainty until correlation can be detected.

Once synchronization has been achieved, it is immediately necessary to develop control over the pseudo-random code clock to prevent small offset in frequency from drifting the code out synchronism. Also, since any tracking error translates directly into a loss of signal power, it is important that this control reduces any error to a value that is as small as possible. Tracking of the pseudo-random code is accomplished by sensing any synchronization error and adjusting the frequency or phase of the pseudo-random clock to improve the synchronization.

4. Selective broadcast

In line with the recommendation of the above mentioned feasibility study, IBINET could be defined technically as a "Packet-transmission point-to-multipoint satellite network".

Broadcasting is usually thought of as having one transmitter and many receivers. However, when a communications satellite is used for two-way signals, a form of broadcasting is taking place in which there are many transmitters. Each earth station is, in effect, a broadcasting transmitter because its signal reaches all other earth stations, whether they want it or not. Each earth station, like a radio set, tunes in only to that signal it wants to receive.

Because of this broadcasting nature of satellites, it is too simplistic to think of a satellite as a 'cable in the sky'. It is much more than that. A signal sent up to the satellite comes down everywhere

over a very wide area. To maximize the usefulness of the satellite for telecommunications, any user in that area should be able to request a small portion of the satellite capacity at any time and have it allocated to him if at that moment there is any capacity free. Just as with a telephone network, to make it really useful any user should be able to call any other user when he wants; however, it is not easy to put a telephone exchange in the satellite, at least not yet. The equipment on the satellite needs to be simple and reliable, because equipment failures cannot be repaired, and needs to be light and consume as little power as possible. To achieve the desirable multiple-access capability, ingenious ways have been devised for allocating satellite capacity to geographically scattered users, permitting them to intercommunicate.

An important point must be made, however, regarding the selectivity of the broadcast: IBINET's flexibility lies basically in its facility to transport and install the receive-only earth stations (0.6 to 0.8 m diameter) without affecting any other point of the network, limited only by the satellite radiation coverage pattern.

However, in spite of the intergovernmental character which IBINET could have, this network is designed as a private point-to-multipoint network for each member and therefore with the possibility of selecting the user or users who will receive the information transmitted. According to the technical specifications which are currently being drawn up, each IBINET up-link shall be able to direct the information transmitted to one, to several or to all the receive earth stations of the network, through administration commands. The IBINET organisation will manage the resources of the space segments, establishing the use schedules and the technical and legal operating norms.

5. Typical applications

The information services that could be offered through a network such as IBINET are very varied, and for this reason it has been decided to classify them into four tentative major levels or categories, depending on the volume of information to be disseminated, the necessary updating cycles, and above all according to the type of remote terminal

that would be required for their appropriate use and application.

- The first level refers to the information which, once disseminated, does not require processing, or at the most requires printing for the records. The terminal connected to the micro-earth station is a dumb terminal or a serial printer. An example of this first level is news items, generally the main headings that appear on any monitor in airports or other public places, which are nowadays, to a large extent, transmitted via cable.

- The second level requires a semi-intelligent terminal which may store one or two pages or screens, and possibly following a simple stored program, enables only certain concepts of what was disseminated to be presented selectively on the screen. An example of this second level is stock market information, which should have a rapid updating and personalised interest profiles: the progress of certain stocks in particular.

- The third level enables the information to be processed on reception and stored locally. This involves intelligent terminals with microcomputer which during reception are capable of producing graphs, comparative analyses and storing the information on mini-disks (floppy or hard disks) for subsequent off-line use. This level, perhaps the most appropriate to the developing countries for useful and immediate application, will be demonstrated by a simulation of meteorological information, and of the transmission of certain information banks on tropical medicine and on economic and financial trends and forecasts.

- The fourth level is represented by the use of a minicomputer which has the function of node receiver. It enables the reception of large data banks which could be locally stored in high-capacity disks, and accessed through terminals connected to this node. This level constitutes the nucleus of the regional or national information systems, regularly fed through IBINET. The dissemination of certain public utility software can also be conceived at this level.

Technical definitions and recommendations for the process of sending of information through the up-links, ranging from the formatting of the data stream to the management of the data bases, also exist for each one of these levels.

6. Space segment considerations

The IBINET feasibility study verified the possibility for transmission stations to operate in the 5.9 to 6.4 GHz band with antennas of 5 meters in diameter.

However, the study clearly recommends that IBINET be approached, at least in its first stages, in a different way for technological, legal and political considerations. Firstly, and independent of their technological feasibility, the networks adopting this technique should preferentially use domestic satellites, the regulation of which is only subject to the norms of the country itself. Few developing countries have satellites for domestic use. On the other hand, telecommunications services in the majority of countries are offered by official bodies who actively participate at international level (ITU, CCITT, ISO) and who regulate at national level the electro-magnetic spectrum.

For these reasons in particular, the study recommended close collaboration with the competent local authorities and, at international level, INTELSAT support for the 'space segments'. Bearing in mind that 106 countries are currently member of INTELSAT, the use of this existing infrastructures for IBINET is clearly desirable. IBINET therefore intends to use INTELSAT satellites for the space segment.

7. Pilot experiment

The first goal of the IBINET project is to carry out a demonstration in order to acquire experience and evaluate the concept of an international data network; a three phase programme was therefore recommended.

- The first phase includes the definition of the technical specifications of IBINET and the development engineering;
- The second phase is a pilot demonstration with a Rome-to-Fucino-to-Rome link;
- The third phase, which is optional and dependent on the outcome of the first two phase, is the implementation of a fully operational data distribution network.

The technical specifications of IBINET will in-

clude the following matters:

- specifications for the network,
- the data base systems,
- the transmission mode
- uplink,
- satellite specifications,
- ground stations,
- the receiving terminals

It also includes the project and task definitions and an outline of the final report or evaluation of the experimental demonstration.

The engineering developments will concern two main areas:

- The development of a circular polarised feed for the receive-only micro earth stations, suitable for use with INTELSAT satellites;
- The software adaptation for the receiving terminals, following the technical specification of the network.

The pilot demonstration is the second phase of the experiment and involves a Rome-to-Fucino terrestrial link and a Fucino-to-Rome satellite link.

In both cases, the origin of the information to be transmitted will be IBI itself, or to be more precise the IBI computing system, and the up-link will be implemented at the Fucino facilities of Telespazio, the Italian authorized agency for space communications, which is co-sponsoring the experiment. A few micro earth receiving stations, with their respective terminals will be installed by Telespazio for the necessary demonstration and experimentation purposes.

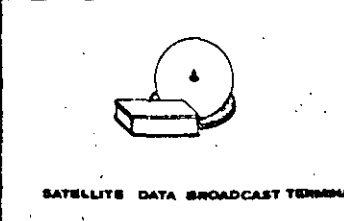
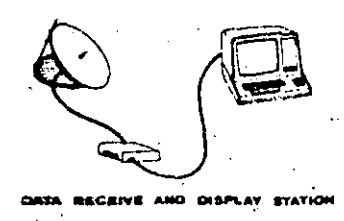
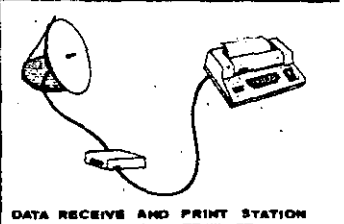
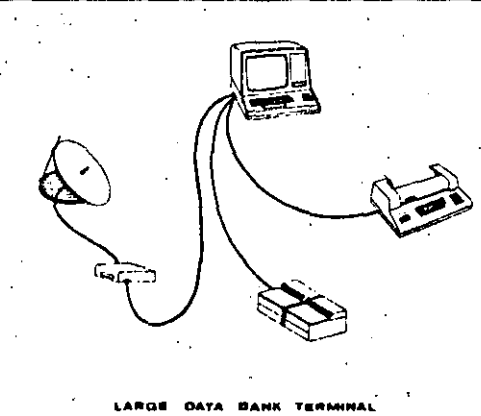
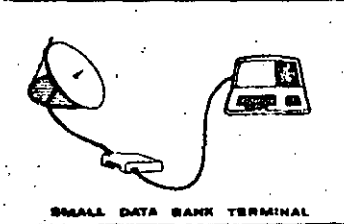
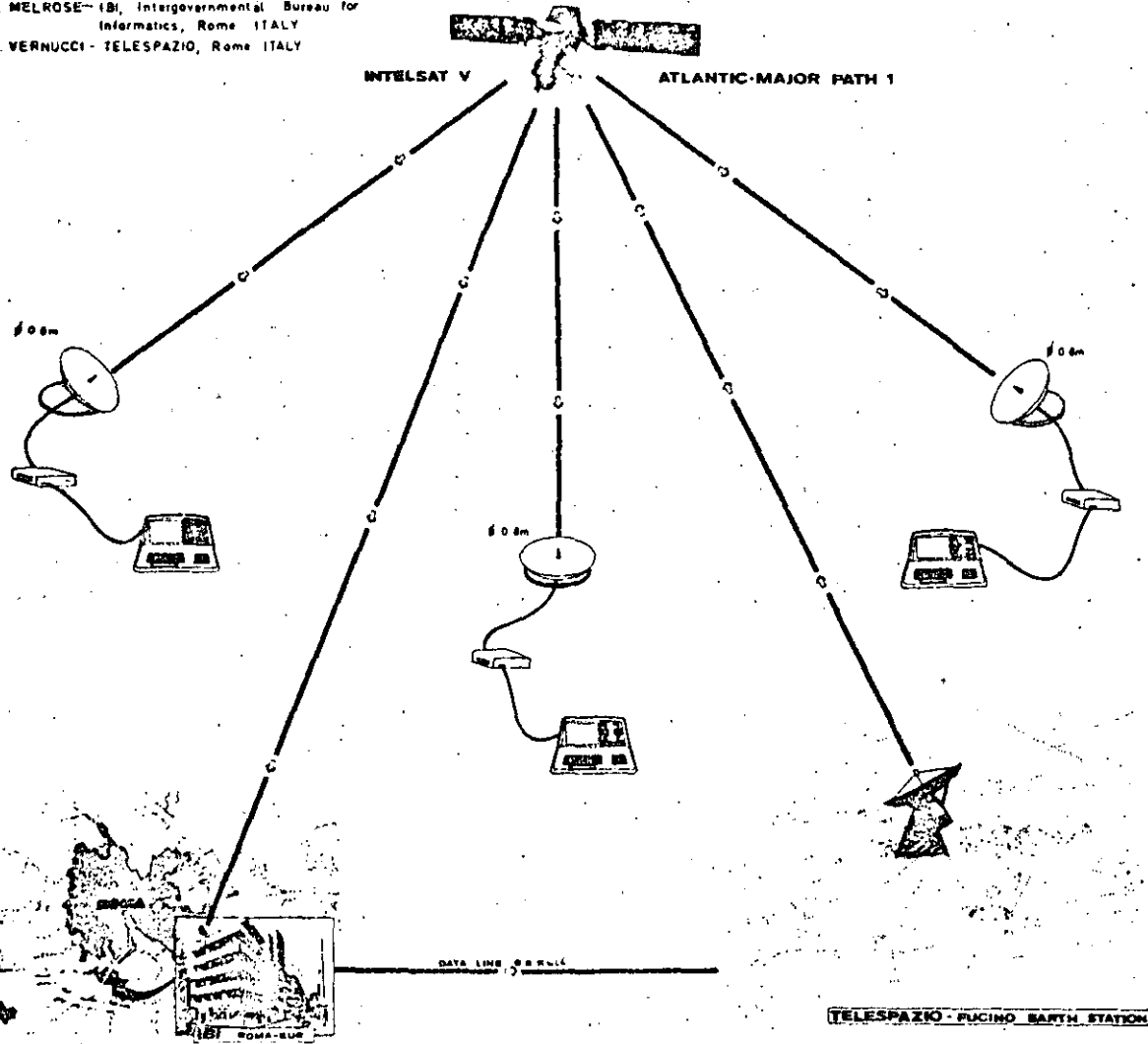
It is intended that the pilot test shall comprise, on a reduced scale, most of the operational details of the network which could help at a later date when the definitive specifications of IBINET are drawn up. Therefore, special attention will be paid to the overall aspect of the proposed system and not merely to the experimentation of a telecommunications technique.

During the test, applications typical to the different levels of information services which could be incorporated into IBINET when it is operational will be presented.

At all events, applications will be presented which are of interest to developing countries, using however, for demonstration purposes, simulated information with no commercial or political value whatsoever.

AN EXPERIMENT OF DATA BROADCAST TO MICRO TERMINALS VIA SATELLITE BY SPREAD SPECTRUM TECHNIQUES

by:
E. MELROSE - IRI, Intergovernmental Bureau for Informatics, Rome ITALY
A. VERNUCCI - TELESPAZIO, Rome ITALY



One of the most important aspects to be tested during the pilot experiment refers to the mechanisms of the network. In effect, the IBINET organisation will establish a mechanism for dynamically allocating resources (channels, transmission time, speed, coverage, etc.) at member's request. However, a certain technical homogeneity has been imposed already by adopting a fixed number of characters for the transmission packages (transparent, in fact, to the user who transmits and receives) which will possibly be complemented by a system of obligatory 'headers' for each transmission originated in any network up-link.

The processing of such headers and the volume of packages transmitted would be elements for monitoring and managing the network. Figure 1 illustrates diagrammatically the system configuration to be established for the pilot experiment.

8. Link parameters and quality

As to the link parameters, only the down-link will be discussed here, as the up-link yields a negligible contribution to the overall link, due to the use of a large transmit antenna.

IBINET is expected to utilize the hemispheric beams of the Intelsat V-series satellites. These beams cover the IBI Member States in the Americas and Africa. The experiment will however be carried out using an Intelsat V transponder connected to a zone beam, having a much narrower coverage. However the satellite EIRP will be the same as that expected in an operational situation (17 dBW minimum).

Due to satellite power limitations, the bandwidth requirement is larger than strictly required

(18 MHz against 5 MHz). The 0.8 m receive terminal has a 27.5 dB gain with a 160°K FET front-end.

Degradation due to intermodulation was computed to be negligible. The nominally available E/No is 14.7 dB, but, taking into account pointing losses, sun interference and rain margin, a worst-case of 11.7 dB should be considered.

An E/No of 11.7 dB is sufficient to attain the quality objective of the link ($BER = 10^{-5}$). This taking into account a 2 dB implementation margin with respect to the theoretical value for $BER = 10^{-5}$.

It should be noted that the quality to the user will be $BER = 10^{-7}$. This improvement is achieved by the use of a FEC code implemented within the individual data packets.

9. Expected results

High technology should not be an exclusive prerogative of the industrialized countries, and should also be put to work for the benefit of developing countries.

It was on the basis of this idea that the IBINET project was launched; therefore a full comprehension of the problems that it may bring about and also a clear vision of the advantages that its implementation could hold for the developing countries is required.

The success of the experiment that is going to be carried out jointly with Telespazio will be achieved through making the authorities and potential users aware of what is involved. It is upon the success of this exercise that the following phase to put IBINET into operation will depend.

FORWARD ERROR CORRECTION SCHEMES FOR DIGITAL COMMUNICATIONS

VIJAY K. BHARGAVA

THE utility of coding was demonstrated by the work of Shannon in 1948. Shannon's work established that the ultimate limit of performance set by the noise on the channel is not the accuracy, but the rate at which data can be reliably transmitted.

A block diagram which describes the digital communication process using forward error correction (FEC) is shown in Fig. 1. This paper shall not be concerned with error control coding schemes which involve some type of detection and retransmission—the so-called automatic repeat request (ARQ) procedures [1].

Encoder—Decoder (CODEC)

Historically, the coding systems have been separated into block and convolutional error-correcting techniques.

In an (n, k) linear block code a sequence of k information bits is algebraically related to $n-k$ parity bits to give an overall encoded block of n bits. Usually modulo-2 arithmetic is used, which is simply the EXCLUSIVE-OR operation in logic. In this arithmetic $1 \oplus 1 = 0$ and there are never any "carries." Hence, an odd number of 1's sums to 1. Linear codes form a linear vector space and have the very important property that two code words can be added to produce a third code word. The code rate is $r = k/n$, and n is called the block length. Note that the introduction of error-control coding requires more capacity; this can be in the form of wider bandwidth, longer bursts in time division multiple access (TDMA) systems, or a

higher "chip" rate (and hence a higher bandwidth) in spread spectrum systems; if the same processing gain is needed.

The Hamming weight of a code word \underline{c} , denoted $w(\underline{c})$, is defined to be the number of nonzero components of \underline{c} . For example, if $\underline{c} = (110101)$, then $w(\underline{c}) = 4$. The Hamming distance between two code words \underline{c}_1 and \underline{c}_2 , denoted $d(\underline{c}_1, \underline{c}_2)$, is the number of positions in which they differ. For example if $\underline{c}_1 = (110101)$ and $\underline{c}_2 = (111000)$ then $d(\underline{c}_1, \underline{c}_2) = 3$. Clearly, $d(\underline{c}_1, \underline{c}_2) = w(\underline{c}_1 \oplus \underline{c}_2) = w(\underline{c}_3)$, where \underline{c}_3 , for linear codes, is a code word. Therefore, the distance between any two code words equals the weight of one of the code words and the minimum distance d for a linear block code equals the minimum weight of its nonzero code words.

A code can correct all patterns of t or fewer random errors, and detect all patterns having no more than s errors, provided that $s + t + 1 \leq d$. Only if the code is used for error correction can the code correct all patterns of t or fewer random errors, provided that $2t + 1 \leq d$.

Convolutional codes are a subset of the so-called tree codes. A convolutional code of rate $1/v$ may be generated by a K stage shift register and v modulo-2 adders. A simple example is the rate $1/2$ convolutional encoder shown in Fig. 2.

Information bits are shifted in at the left, and for each information bit the output of the modulo-2 adders provide two channel bits. The constraint length of the code expressed in information bits is defined as the number of shifts over which a single information bit can influence the encoder output. For the simple binary convolutional code, the constraint length is equal to K , the length of the shift register.

The decoder uses the redundancy introduced in the process of encoding and sometimes the reliability (defined below) of

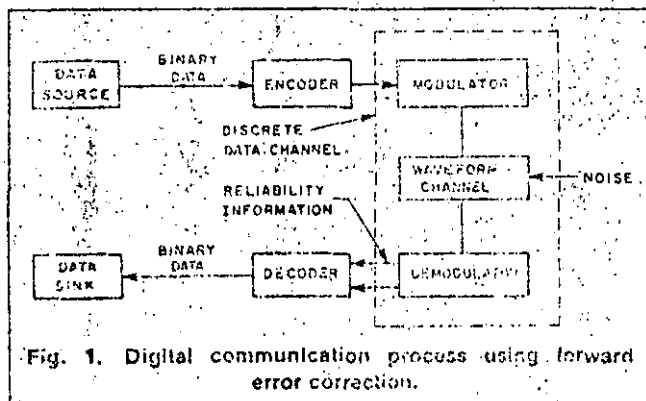


Fig. 1. Digital communication process using forward error correction.

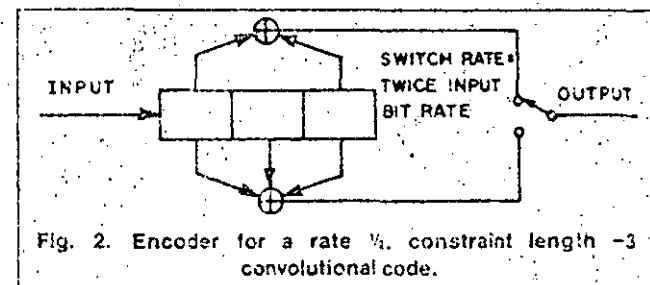
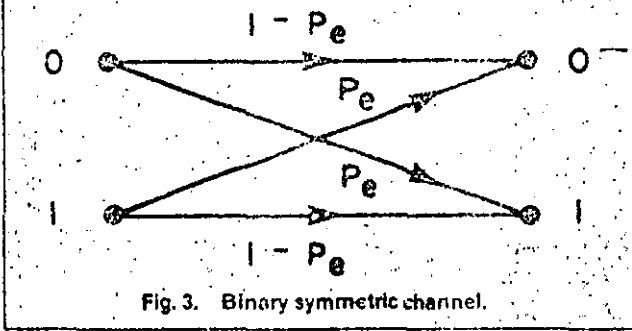


Fig. 2. Encoder for a rate $1/2$, constraint length 3 convolutional code.



the received information to decide which information bit was actually sent.

Modulator—Demodulator (MODEM)

The encoded sequence is suitably modulated and transmitted over the noisy channel. In systems where coherent demodulation is possible (that is, where a carrier reference can be obtained), phase shift keying (PSK) is often used. In binary PSK an encoded 1 is represented by the wave form $s_1(t) = A \cos \omega_c t$, while an encoded 0 is represented by the antipodal signal $s_0(t) = -s_1(t) = A \cos(\omega_c t + \pi)$, the waveforms changing at discrete times T_s seconds (symbol duration) apart.

The physical channel or the waveform channel consists of all the hardware (for example, filtering and amplification) and the physical media that the waveform passes through in going from the output of the modulator to the input of the demodulator:

The demodulator estimates which of the possible symbols was transmitted, based upon an observation of the received signal. For PSK with white Gaussian noise and perfect phase tracking, the optimum receiver is a correlator or matched filter receiver which is sampled each T_s seconds to determine its polarity. It is easily shown that the voltage z , at the matched filter output at the sample time is a Gaussian random variable with mean $\pm \sqrt{E_s}$, (depending upon whether a 1 or 0 was transmitted) and variance $\sigma^2 = N_0/2$. In the above E_s is the energy per symbol (what we pay) and N_0 denotes the one sided noise spectral density (what we must combat). When a symbol differs from a bit (that is, when we use coding) we will denote the energy per bit by E_b .

Hard Decisions, Soft Decisions

In practical communication systems, we rarely have the ability to process the actual analog voltages z_i (the values taken by the random variable z). The normal practice is to quantize these voltages. If a binary quantization is used, we say that a *hard decision* has been made on the correlator output as to which level was actually sent. In this case, we have the so-called binary symmetric channel (BSC) with probability of error P_e , shown in Fig. 3. For example, in coherent PSK with equally likely transmitted symbols, the optimum threshold is at zero. Then the demodulator output is a zero if the voltage z at the matched filter output is negative. Otherwise, the output is a one.

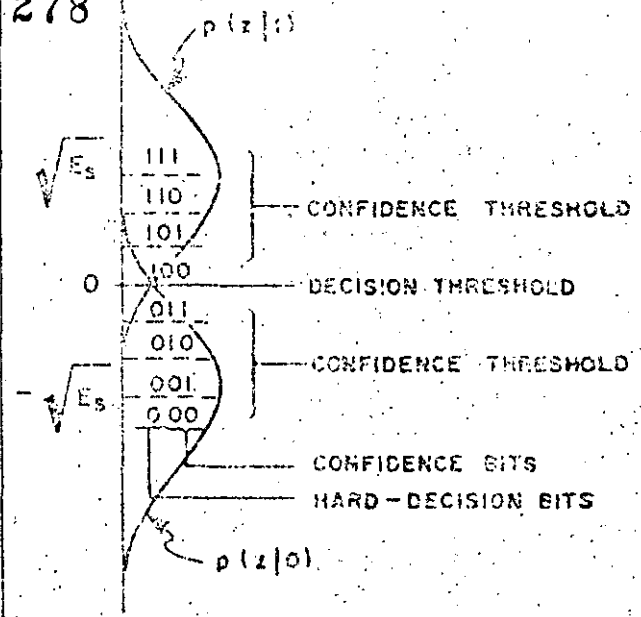


Fig. 4. Three-bit (8-level) soft-decision quantization. $p(z|1)$ and $p(z|0)$ are conditional probability density functions of the matched filter output for a coherent PSK system.

With coding, it is desirable to keep an indication of how reliable the decision was. A *soft-decision* demodulator first decides whether the output voltage is above or below the decision threshold, and then computes a "confidence" number which specifies how far from the decision threshold the demodulator output is. This number in theory could be an analogue quantity, but in most practical applications a three-bit (eight-level) quantization is used.

An example of three-bit quantization is shown in Fig. 4. The input to the demodulator is binary, while the output is 8-ary, delineated by one decision threshold and three pairs of confidence thresholds. The information available to the decoder is increased considerably and translates as an additional gain of 2 dB in most instances [2]. The receiver complexity is increased as an AGC will probably be needed, and three bits will have to be manipulated for every channel bit. The channel resulting from three-bit quantization on a Gaussian channel is called the binary input, 8-ary output, discrete memoryless channel (DMC), and is shown in Fig. 5.

Coding Gain

Before we start our study of codes, consider a Gaussian memoryless channel with one-sided noise spectral density N_0 and under no bandwidth limitation. Let E_b denote the received energy per bit. Then it can be shown that for E_b/N_0 greater than -1.6 dB, there exists some coding scheme which allows us to communicate with zero error, while reliable communication is not generally possible at lower signal-to-noise ratios. On the other hand, it is well known that uncoded PSK over the same channel will require about 9.6 dB to achieve a bit error rate of 10^{-5} . Thus, as shown in Fig. 6, a potential coding gain of 11.2 dB is theoretically possible. Coding gain is defined as

$$P_{b,h} \geq Q(\sqrt{2E_b r(t+1)/N_0})$$

$$\text{where } Q(x) = \int_x^\infty \frac{1}{\sqrt{2\pi}} e^{-y^2/2} dy.$$

With a soft-quantized PSK demodulator, we have

$$P_{b,s} \geq Q(\sqrt{2E_b r d/N_0}).$$

Recall that for uncoded PSK

$$P_b = Q(\sqrt{2E_b/N_0})$$

Thus, the asymptotic coding gain G_a for the two cases is:

$$G_a \leq r(t+1) = 10 \log r(t+1), \text{ dB (hard decision)}$$

$$G_a \leq rd = 10 \log rd, \text{ dB (soft decision)}$$

The above indicates that soft decision decoding is about 3 dB more efficient than hard decision decoding at very high E_b/N_0 . A figure of 2 dB is more likely at realistic values of E_b/N_0 .

Block Codes and Their Decoding

We shall illustrate the idea of a block code by the following example:

1. Phenomenal decrease in the cost of digital electronics.
2. Significant improvement in various decoding algorithms.
3. Much slower (or no) decrease in the cost of analog components, such as power amplifier, antenna and so on.

Asymptotic coding gain, a figure of merit for a particular code, depends only on the code rate and the minimum distance. To define it, consider a t -error correcting code with rate r and minimum distance $d \geq 2t + 1$. If we use the code with a hard decision PSK demodulator, it can be shown that the bit error rate P_b is [2]

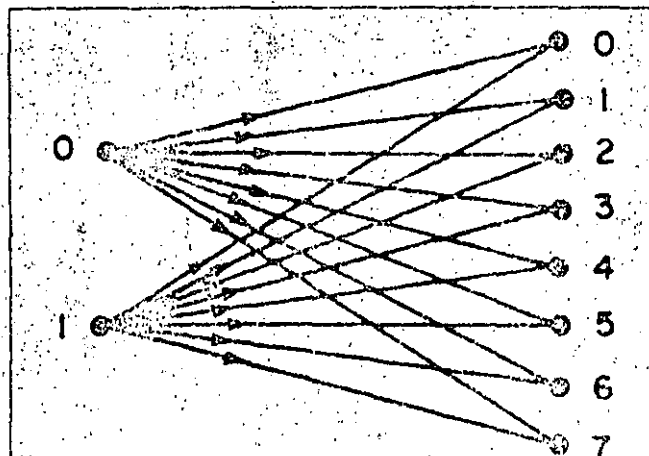


Fig. 5. Eight-level soft quantized DMC produced by a three-bit quantizer on a Gaussian channel.

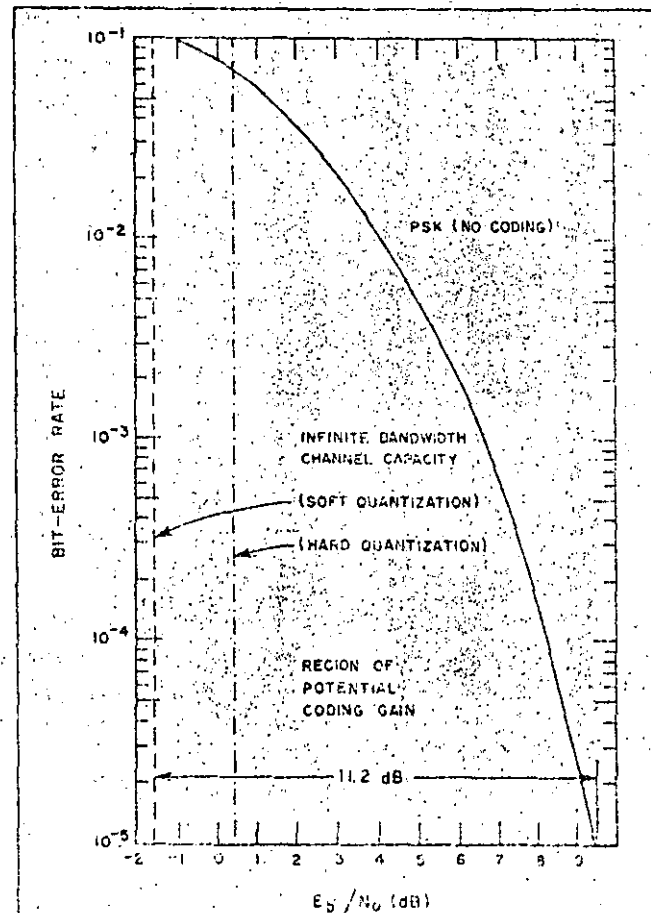


Fig. 6. Performance of uncoded PSK over white Gaussian channel.

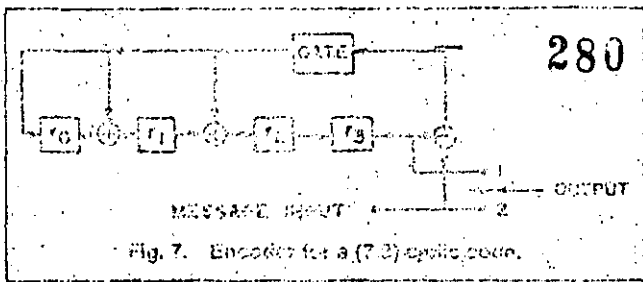


Fig. 7. Encoder for a (7,3) cyclic code.

Example 1

Consider the set of code words (000000), (001101), (010011), (011110), (100110), (101011), (110101) and (111000). These $2^3 = 8$ code words form a vector space of dimension three and thus a (6,3) code. The minimum weight (of nonzero code words) is 3 and hence the minimum distance is 3. Thus, the code is single-error correcting.

Block codes are also called parity check codes, for if $\underline{c} = (c_1, c_2, c_3, c_4, c_5, c_6)$ is a code word in the code of Example 1, then knowing c_1, c_2, c_3 allows one to solve for the other three bits by using the following parity check equations:

$$\begin{aligned} c_1 \oplus c_3 &= c_4 \\ c_1 \oplus c_2 &= c_5 \\ c_2 \oplus c_3 &= c_6 \end{aligned}$$

The code of this example is said to be in the systematic form; the first three bits in any code word can be considered as the message bits while the last three bits, which are calculated from the first three bits, are the redundant or parity bits.

Cyclic Codes

It is perhaps a remarkable fact that many of the important block codes found to date can be reformulated to be cyclic codes or closely related to cyclic codes. For such codes, if an n -tuple $\underline{c} = (c_0, c_1, c_2, \dots, c_{n-1})$ is a code word, the n -tuple $\underline{c}' = (c_{n-1}, c_0, c_1, \dots, c_{n-2})$ obtained by shifting \underline{c} cyclically one place to the right is also a code word. This class of codes can be easily encoded using linear shift registers with feedback. Further, because of their inherent algebraic structure, the decoding has been greatly simplified, both conceptually and in practice.

Examples of cyclic and related codes include the Bose-Chaudhuri-Hocquenghem (BCH), Reed-Solomon, Hamming, maximal-length, Reed-Müller, Golay, quadratic residue, projective geometry, Euclidean geometry, difference sets, Goppa, and quasi-cyclic codes. The classes form overlapping sets so that a particular code may be a BCH code and also a quadratic residue code. Recent applications of codes from this family to digital communication include a (31,15) Reed-Solomon code for the joint tactical information distribution system (JTIDS), a (127,112) BCH code for the INTELSAT V system, and a (7,2) Reed-Solomon code for the air force satellite communications (AFSATCOM) wideband channels [1].

Example 2

Consider the encoder of Fig. 7, which generates a (7,3)

cyclic code. Suppose we wish to encode (010). With the gate turned on and the switch in position 2, information bits shift into register and into the channel sequentially, and the contents of the shift register are as follows:

	r_0	r_1	r_2	r_3
Initial state	0	0	0	0
First shift	0	0	0	0
Second shift	1	1	1	0
Third shift	0	1	1	1

The gate is then turned off, the switch is thrown to position 1 and the four parity bits (0111) are shifted to obtain the encoded word as

(0111 010)

The Concept of Syndrome and Error Detection

The basic element of the decoding procedure consists of computing the syndrome defined according to the following operation: re-encode the received information bits to compute a parity sequence in exactly the same fashion as the encoder; compare these parity bits to the corresponding parity bits actually received using a modulo-2 adder whose output forms the syndrome.

Clearly, when no errors have occurred, the parity bits computed at the decoder will be identical to those actually received, and the syndrome bits will be zero. If the syndrome bits are not zero, then errors have been detected.

For error correction the syndrome is processed further. Thus, error correction is substantially more involved than error detection.

Summary of Important Classes of Block Codes

In this section we discuss the characteristics of some important classes of block codes. Most of them are cyclic (or related to cyclic codes). Further, we limit ourselves to only binary codes.

Bose-Chaudhuri-Hocquenghem (BCH) Codes

The BCH codes are the best constructive codes for channels in which errors affect successive symbols independently. These codes are cyclic and have the following parameters:

$$\begin{aligned} \text{Block length: } n &= 2^m - 1, m = 3, 4, 5, \dots \\ \text{Number of information bits: } k &\geq n - mt \\ \text{Minimum distance: } d &\geq 2t + 1 \end{aligned}$$

Reed-Solomon Codes

Each symbol here can be represented as m bits. These codes have the parameters:

$$\begin{aligned} \text{Symbols: } m &\text{ bits per symbol} \\ \text{Block length: } n &= 2^m - 1 \text{ symbols} = m(2^m - 1) \text{ bits} \\ \text{Number of parity symbols: } (n - k) &= 2t \text{ symbols} = m \cdot 2t \text{ bits} \\ \text{Minimum distance: } d &= 2t + 1 \text{ symbols} \end{aligned}$$

Example 2

Let $t = 1$ and $m = 2$. Denoting the symbols as 0, 1, 2, and 3,

we can write their binary representation as

- 0 = 00
- 1 = 01
- 2 = 10
- 3 = 11

and we have a code with the following parameters:

$$n = 2^2 - 1 = 3 \text{ symbols} = 6 \text{ bits}$$

$$(n - k) = 2 \text{ symbols} = 4 \text{ bits}$$

This code can correct any inphase burst: (i.e. spanning a symbol) of length 2.

For example, suppose the code word (1,2,3) was transmitted. We write it as (01 10 11). Since the code is one-symbol error correcting, it will decode any inphase burst error of length 2. In general, a t symbol error correcting Reed-Solomon code can correct t inphase bursts of length m bits in each code word.

For any (n,k) code with minimum distance d , it can be shown that $d \leq n - k + 1$. Since $d = n - k + 1$ for RS codes, they are called maximum distance separable. Reed-Solomon codes are now commercially available with development spurred by military tactical communication.

Reed-Solomon codes are extremely well suited for burst-error correction and for use as outer codes in a powerful coding system known as the concatenated coding system [2]. The basic idea of concatenation is to factor the channel encoder and decoder in a way shown in Fig. 8. By choosing an inner code (block or convolutional) appropriately and taking a Reed-Solomon code as the outer code, lower decoding complexity and larger coding gains are possible compared to an unfactored system.

Golay Code

This is a very special three-error correcting (23,12) cyclic code with minimum distance 7 and is based on the following tantalizing number theoretic fact: $1 + \binom{23}{1} + \binom{23}{2} + \binom{23}{3} = 2048 = 2^{11}$, which makes the code a "perfect" code. The code has been widely used as a (24,12) code with minimum distance 8 by adding an extra parity bit which is a parity check over the other 23 bits. Unfortunately, the Golay code does not generalize to other combinations of n and k .

Hamming Codes

These are cyclic codes having the following parameters:

$$\text{Block length: } n = 2^m - 1$$

$$\text{Number of parity bits: } k = m$$

$$\text{Minimum distance: } d = 3$$

Maximum-Length Codes

These are cyclic codes with the following parameters:

$$\text{Block length: } n = 2^m - 1$$

$$\text{Number of information bits: } k = m$$

$$\text{Minimum distance: } d = 2^{m-1} - 1$$

These codes are related to maximal-length sequences used extensively in spread spectrum communications and for closed-loop time-division multiple-access synchronization, to name two examples [1]. They are also called simplex codes, an intriguing contact between algebraic coding theory and the geometry of n dimensions [3].

Quadratic Residue Codes

The minimum distances of codes in this family are typically comparable to those of BCH codes of comparable lengths. The quadratic residue codes are cyclic codes with the following parameters:

$$\text{Block length: } n = p \text{ a prime number of the form } 8m \pm 1$$

$$\text{Number of information bits: } k = (p + 1)/2$$

$$\text{Minimum distance: } d > \sqrt{p}$$

The above list is by no means an exhaustive list. For example, we have not mentioned codes based on the combinatorial configurations of finite geometries, Goppa codes, quasi-cyclic codes, to name a few [5].

Decoding of Block Codes

The algebraic structure imposed on block codes has produced a number of decoding techniques for these codes, and the theory is quite well developed. Thus, the various schemes will be touched upon only briefly. To use many of these techniques requires the use of binary quantization (hard decisions) at the demodulator output. The first step is to form the syndrome. In medical parlance, a syndrome is a pattern of symptoms that aids in the diagnosis of a disease. Here the "disease" is the error pattern and a "symptom" is a parity check failure. This felicitous coinage is due to Hagelbarger [3]. To correct errors, the syndrome is processed further using any one of the following methods:

Table look up decoding—It can be shown that there is a unique correspondence between the 2^{n-k} distinct syndromes and the correctable error patterns. Thus, for codes with small redundancy we can store the error patterns in a read-only memory (ROM) with the syndrome of the received word forming the address. The error pattern would then be added modulo-2 to the received sequence to produce the transmitted code word.

Example 3

For the code of Example 1, the following correspondence can be established:

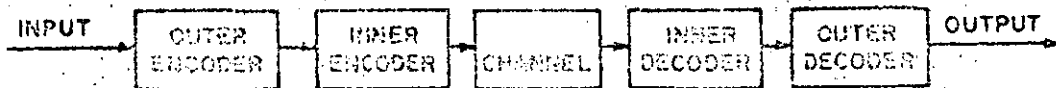


Fig. 8. Concatenated coding system.

Correctable error pattern	Syndrome
000000	000
000001	001
000010	010
000100	100
001000	101
010000	011
100000	110
100001	111

Suppose that the code word $\underline{c} = (110101)$ is transmitted and $\underline{r} = (010101)$ is received. We calculate the syndrome of \underline{r} as:

$$\begin{aligned} \text{received parity bits} &= 101 \\ \text{parity bits obtained by re-encoding received information} &= 011 \\ \therefore \text{Syndrome} &= 110 \end{aligned}$$

From the table we note that (110) is the syndrome corresponding to the correctable error pattern $\underline{e} = (100000)$. Thus $\underline{r} + \underline{e} = (010101) + (100000) = (110101)$ is identified as the transmitted code word. Now suppose (011110) is transmitted and (101110) is received. The syndrome can be computed as before to obtain (101) which corresponds to (001000). The decoded word is identified as (101110) + (001000) = (100110). This is an incorrect decoding since the error pattern caused by the channel (110000) is not a correctable error pattern. This code corrects single errors in any position and one error pattern of double errors. Thus, as noted earlier, it is a single error correcting code.

Algebraic techniques—The most prominent among these is the iterative decoding algorithm for BCH codes due to Berlekamp. It is perhaps the deepest and most impressive theoretical result in coding theory (block or convolutional). A systems engineer who wishes to minimize the complexity of a BCH decoder is still well advised to use Berlekamp's procedure [3]. The algorithm was interpreted in terms of the design of a minimum-length shift register to produce a given sequence by Massey [2]. The key idea is to compute a so-called error-locator polynomial and solve for its roots. The complexity of this algorithm increases only as the square of the number of errors to be corrected. Thus, it is feasible to decode powerful codes. The use of Fourier-like transforms has recently been proposed as a vehicle for reducing decoder complexity [2].

The BCH decoder could be implemented at moderate data rates in a special purpose processor with an associated finite field arithmetic unit, and memory. Highly parallel realization has been used to achieve very high data rates (40 Mbps) [2].

The standard BCH decoding algorithm is a *bounded-distance* algorithm. That is, no error patterns of more than t errors can be corrected. This technique does not generalize easily to utilize soft decisions. At present, soft decisions can only be utilized via some other techniques in combination with the standard hard decision BCH decoding algorithm. Two such schemes are Forney's generalized minimum distance decoding and Chase's algorithm [2].

Permutation decoding is another example of algebraic decoding and the so-called error trapping is a special case of it [4]. This technique is based on the fact that if the weight of the syndrome for an (n, k) t -error correcting code is at most t , then the information bits are correct. If the weight of the syndrome is greater than t , then at least one information bit is incorrect.

Majority logic decoding—There are codes that, because of the special form of their parity check equations, are majority logic decodable. Majority logic decoding is the simplest form of threshold decoding that is applicable to both block and convolutional codes. Recall that any syndrome bit is a linear combination of error bits. Thus, a syndrome bit represents a known sum of error bits. Further, any linear combination of syndrome bits is also a known sum of error bits. Hence, all 2^{n-k} such possible combinations of syndrome bits are of the known sum of error bits available at the receiver.

In the simplest case, decoding for these codes is performed on a bit-by-bit basis. For every received bit several parity check equations are checked giving rise to a particular value. The element 1 or 0 receiving the majority votes is taken to be the correct value for that bit. Many examples of this type of decoding procedure are given in [1].

Convolutional Codes and Their Decoding

Convolutional codes using either Viterbi or sequential decoding have the ability to utilize whatever soft-decision information might be available to the decoder. It is not surprising that they have been used widely even though their theory is not as mathematically profound as that of block codes. Most good convolutional codes have been found by computer search rather than by algebraic construction.

Convolutional codes can be studied from many different approaches. For the purpose of illustrating their decoding methods, it is necessary to outline both the tree and the trellis approaches.

The convolutional encoder of Fig. 2 can be described by the code tree of Fig. 9. Each branch of the tree represents a single input bit—an input zero corresponds to the upper branch and an input one corresponds to the lower branch. Clearly any sequence of input bits traces out a particular path through the tree. Specifically, a 10110 sequence traces out a 11 01 00 10 10 output sequence.

In Fig. 9 we have labeled each node of the tree with a member from the following set of binary pairs: {00, 01, 10, 11} corresponding to the contents of the two left-most positions of the encoder register at that point in the tree. This number is called the state of the encoder.

We see that the tree contains redundant information which can be eliminated by merging, at any given level, all nodes corresponding to the same encoder state. The redrawing of the tree with merging paths has been called a trellis by Forney. Figure 10 represents a trellis for the convolutional encoder of Fig. 2. As before, an input 0 corresponds to the selection of the upper branch and an input 1 to the lower branch. Each

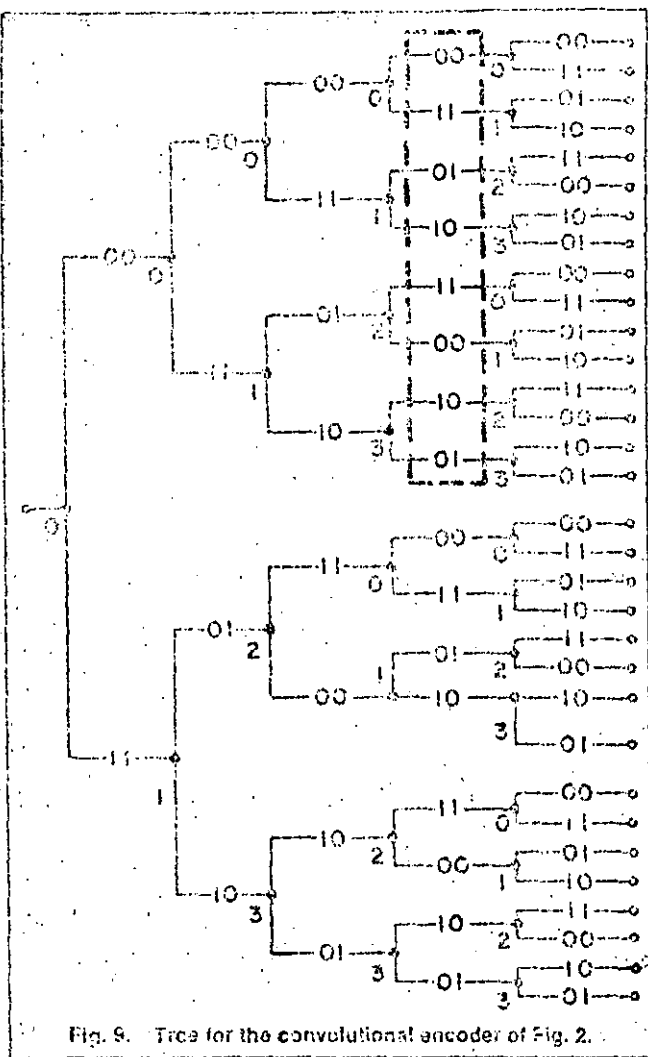


Fig. 9. Tree for the convolutional encoder of Fig. 2.

possible input sequence corresponds to a particular path in the trellis.

Unlike block codes, several distance measures have been proposed for convolutional codes, and each one is important and useful for particular decoding techniques.

The n th order column distance function $d_c(n)$ of a convolutional code is the minimum Hamming distance between all pairs of code words of length n branches which differ in their first branch of the code tree. The column distance function is a nondecreasing function of n , and assumes two particular values of special interest: d , the minimum distance of the code when $n = K$, the constraint length of the code; and d_f , the free distance of the code when $n \rightarrow \infty$.

The minimum distance of a convolutional code is the important parameter for determining the error probability of the code when used with threshold decoding. The free distance is useful in determining the code performance with Viterbi decoding and sequential decoding.

Decoding of Convolutional Codes

The problem of decoding a convolutional code can be thought of as attempting to find a path through the trellis or the tree by making use of some decoding rule.

Viterbi Decoding Algorithm

This algorithm leads to a maximum likelihood decoder for convolutional codes. In fact, it applies to any trellis code, not just convolutional codes. The significance of the trellis viewpoint is that the number of nodes in the trellis does not continue to grow as the number of input bits increases but remains at 2^{K-1} . The Viterbi algorithm computes a "metric" for every possible path through the trellis. It then discards a number of paths at every node that exactly balances the number of new paths that are created. Thus, it is possible to maintain a relatively small list of paths that are always guaranteed to contain the maximum-likelihood choice. The decoding algorithm can easily operate on soft-decided data. This is a major advantage of Viterbi decoding.

Viterbi decoding is presently the most important decoding technique for providing coding gain for a variety of channels. Unfortunately, it has been well over a decade since there have been any fundamentally new ideas in Viterbi decoding, and that technology appears to be near the asymptote of its learning curve [9].

We note that the complexity of the Viterbi algorithm is an exponential function of the code's constraint length K ; unfortunately, the larger K is, the better the code is likely to be (that is, the larger are the coding gains that can be obtained). We are motivated to consider decoding algorithms that will work on convolutional codes with very large values of K , say $K \gg 10$, the present limit of Viterbi decoders.

One last point worth mentioning is that Viterbi decoding does not perform very well in a bursty channel. In those channels, interleaving of data may thus have to be considered to obtain low correlation between noise samples. However, interleaving requires a significant increase in the encoding delay which may not be acceptable in certain applications.

Sequential Decoding

The complexity of sequential decoders is relatively independent of constraint length, so that codes with much larger constraint lengths can be used. A more rapid rate of change of error probability is achieved with increasing E_b/N_0 . This technique is more suitable than Viterbi decoding when low bit error rates ($< 10^{-5}$) are required.

Sequential decoding was first introduced by Wozencraft but the most widely used algorithm to date is due to Fano. It is an efficient method for finding the most probable code word, given the received sequence, without searching the entire tree. The explored path is probably only local; that is, the procedure is suboptimum. The search is performed in a sequential manner, always operating on a single path, but the decoder can back up and change previous decisions. Each time the decoder moves forward, a "tentative" decision is made. If an incorrect decision is made, subsequent extensions of the path will be wrong. The decoder is eventually able to recognize this situation. When this happens, a substantial amount of computation is needed to recover the correct path. Backtracking and trying alternate paths continues until it finally decodes successfully.

A major problem with sequential decoding schemes is that

the number of computations required in advancing one node deeper into the code tree is so ill-behaved a random variable that even with very fast decoding circuitry and very large buffers, performance is limited by the probability of buffer overflow [9].

Threshold Decoding

Some convolutional codes are threshold decodable in that several parity checks are calculated for each message bit and if they exceed a threshold, a decision on the correctness of the bit is made. Moderate values of coding gain (1 to 3 dB) can be obtained with relatively inexpensive decoders and limited amount of redundancy.

Diffuse threshold decoding and the Gallager adaptive burst-finding scheme are two important variations of threshold decoding. These algorithms can also deal with burst errors [1].

Comparison of Block and Convolutional Codes

The theory of block codes is much older and richer than the theory of convolutional codes and the discussion on block codes is much longer than the discussion on convolutional codes. However, until recently this unbalance did not apply to practical applications. The discussion presented here is applicable to an additive Gaussian white noise channel. For spread spectrum systems with jamming and fading channels, the benefits of using codes (either block or convolutional) are even more spectacular.

We will take as our basis of comparison an uncoded BPSK system employing coherent detection. The same can be extended to QPSK, since the four-phase modulation may be considered as being the superposition of two BPSK systems each acting upon the orthogonal sine and cosine components of the carrier signal. We will assume that the information rate is fixed for all coded systems. The coded system will require more RF bandwidth. Comparisons among different techniques will be made at bit error rates $= 10^{-5}$ and 10^{-8} . Table 1 has been adapted from [2]. Here the column labelled "data rate capability" is taken to be the following: low (less than 10

Kbps), moderate (10 Kbps to 1 Mbps), high (1 Mbps to 20 Mbps) and very high (greater than 20 Mbps).

At moderate and high data rates for a given level of complexity, convolutional codes with Viterbi decoding appears to be the most attractive technique. This assumes that there is no appreciable interference other than Gaussian noise; it also assumes that a decoded bit error rate of 10^{-5} is satisfactory and that the overall system transmits long sequences of bit streams. This advantage to the Viterbi algorithm follows because, in order to apply an algebraic decoding algorithm to a block code it is necessary to use hard-decisions, whereas the Viterbi algorithm can be adapted to accept soft-decisions with relative ease. However, if more efficient algorithms for decoding long block codes with soft decisions are developed, they will undoubtedly be quite competitive.

At very high data rates, concatenated Reed-Solomon and short block code systems can provide roughly the same gain with less complexity than Viterbi decoding.

For larger coding gains at high speeds, sequential decoding with hard decisions appears to be the most attractive choice. At moderate data rates a better case can be made for using sequential decoding with soft decisions.

In situations where the system protocols require the transmission of blocks of data (such as TDMA), all convolutional systems require flushouts and restarts, that is, the CODEC must be set to the all zero state before processing the next block. For such systems, block codes appear to be more attractive.

Threshold decoding is a very attractive technique for systems operating at very high speeds with small complexity. In digital satellite systems a potential use of this technique will be in digital telephony, where the user requires a smaller bit rate than that of the uncoded system but desires extremely high bandwidth efficiency.

For mobile terminals operating in the presence of large doppler offset and doppler rate, and multipath and fading, the use of Reed-Solomon codes with soft-decision decoding ap-

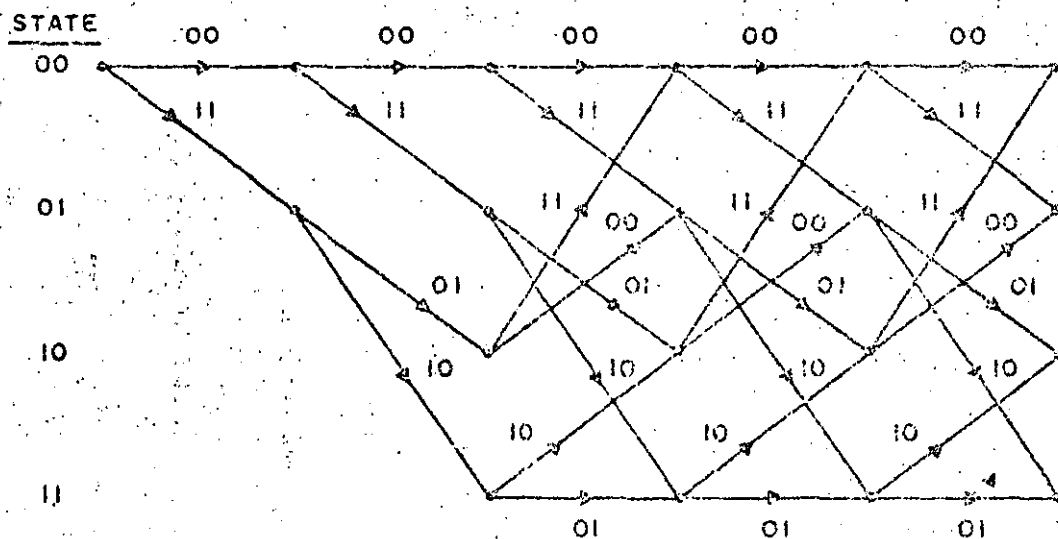


Fig. 10. Trellis for the convolutional encoder of Fig. 2.

TABLE 1
COMPARISON OF MAJOR CODING TECHNIQUES WITH BPSK OR QPSK
MODULATION ON A GAUSSIAN CHANNEL

Coding technique	Coding gain(dB) at 10^{-5}	Coding gain(dB) at 10^{-8}	Data rate capability
Concatenated (RS and Viterbi)	6.5-7.5	8.5-9.5	Moderate
Sequential decoding (soft decisions)	6.0-7.0	8.0-9.0	Moderate
Block codes (soft decisions)	5.0-6.0	6.5-7.5	Moderate
Concatenated (RS and short block)	4.5-5.5	6.5-7.5	Very high
Viterbi decoding	4.0-5.5	5.0-6.5	High
Sequential decoding (hard decisions)	4.0-5.0	6.0-7.0	High
Block codes (hard decisions)	3.0-4.0	4.5-5.5	High
Block codes—threshold decoding	2.0-4.0	3.5-5.5	High
Convolutional codes—threshold decoding	1.5-3.0	2.5-4.0	Very high

appears extremely attractive to combat the bursty nature of the channel. Alternative coding techniques applicable are threshold decoders with interleaving or soft-decision Viterbi decoding with interleaving. However, interleaving requires a significant increase in the encoding delay. In packet networks where decoding, re-encoding and retransmission at several intermediate nodes is required, the delay associated with interleaved convolutional codes may not be acceptable. In such situations the solution might be to avoid interleaving by using one of the block codes suited for this purpose, which, rather than dispersing the bursts by interleaving, exploits it for improved error performance [9].

It should be stressed that a major part of these comparisons is influenced by today's digital integrated circuit technology. Advances in this technology could modify relative comparisons of complexity and achievable data rates.

Conclusion

The purpose of this paper was to introduce forward error correction schemes for digital communications. Various families of codes and their decoding methods were outlined. The performance of these codes over an additive Gaussian white noise channel was discussed.

An enormous amount of literature is now available on coding. For the interested reader, we have narrowed it down to a brief bibliography. More comprehensive lists of references are available in [1,2,4].

The theory of error correcting codes is an active area of research. Some critics claim that coding will be eliminated to conserve spectrum and space. This may not be the final answer since guard spaces, guard times, and minimum antenna separations are themselves users of spectrum, time, and space, and yet do not fully eliminate mutual interference and error [10]. Indeed, what Solomon Golomb wrote well over a decade ago is still very much true:

*A message with content and clarity
Has gotten to be quite a rarity
To combat the terror
Of serious error
Use bits of appropriate parity.*

Acknowledgment 285

The support of the author's research by the Natural Sciences and Engineering Research Council of Canada and by le Programme de Formation de Chercheurs et d'Action Concertée du Gouvernement du Québec is gratefully acknowledged. The author would also like to thank Drs. Jean Conan, David Haccoun, and Gérald Séguin for helpful discussions.

Bibliography

- [1] V. K. Bhargava, D. Haccoun, R. Matyas, and P. Nuspl, *Digital Communications by Satellite: Modulation, Multiple Access and Coding*, NY: Wiley, 1981.
- [2] G. C. Clark, Jr. and J. B. Cain, *Error Correction Coding for Digital Communications*, NY: Plenum Press, 1981.
- [3] R. J. McEliece, *The Theory of Information and Coding*, Reading, MA: Addison Wesley, 1977.
- [4] F. J. MacWilliams and N. J. A. Sloane, *The Theory of Error-Correcting Codes*, Amsterdam, North-Holland and NY: Elsevier/North Holland, 1977.
- [5] I. F. Blake and R. C. Mullin, *The Mathematical Theory of Coding*, NY: Academic Press, 1975.
- [6] W. W. Peterson and E. J. Weldon, Jr., *Error Correcting Codes*, Second Edition, Cambridge, MA: MIT Press, 1972.
- [7] S. Lin, *An Introduction to Error-Correcting Codes*, Englewood Cliffs, NJ: Prentice Hall, 1970.
- [8] E. R. Berlekamp, *Algebraic Coding Theory*, NY: McGraw Hill, 1968.
- [9] E. R. Berlekamp, "The technology of error-correcting codes," *Proc. IEEE*, vol. 68, pp. 564-593, May 1980.
- [10] I. M. Jacobs, "Practical applications of coding," *IEEE Trans. Inf. Theory*, IT-20, pp. 305-310, May 1974.
- [11] J. K. Wolf, "A survey of coding theory, 1967-1972," *IEEE Trans. Inf. Theory*, IT-19, pp. 381-389, July 1973.
- [12] H. O. Burton and D. D. Sullivan, "Errors and error control," *Proc. IEEE*, vol. 60, pp. 1293-1301, Nov. 1972.
- [13] R. T. Chien, "Block coding techniques for reliable data transmission," *IEEE Trans. on Commun. Technol.*, COM-19, pp. 743-751, Oct. 1971.
- [14] A. J. Viterbi, "Convolutional codes and their performance in communication systems," *IEEE Trans. on Commun. Technol.*, COM-19, pp. 751-772, Oct. 1971.
- [15] G. D. Forney, Jr., "Burst correcting codes for the classic bursty channel," *IEEE Trans. on Commun. Technol.*, COM-19, pp. 772-781, Oct. 1971.
- [16] G. D. Forney, Jr., "Coding and its application in space communications," *IEEE Spectrum*, pp. 47-58, June 1970.
- [17] J. F. Hayes, "The Viterbi algorithm applied to digital data transmission," *Communications Magazine*, vol. 13, no. 12, pp. 15-20, March 1975.

Vijay K. Bhargava was born in Beawar, India, on September 22, 1948. He received the B.Sc. (Math. and Eng.), M.Sc. (EE), and Ph.D. (EE) from Queen's University, Kingston, Ontario in 1970, 1972, and 1974 respectively.

He is currently an Associate Professor of Electrical Engineering at Concordia University in Montréal. His research interest is in the area of digital communications with special emphasis on error control coding techniques, cryptography and spread spectrum communications, and he has been a consultant to government agencies and industries in these areas. He is a coauthor of the book, *Digital Communications by Satellite*, published by John Wiley & Sons in December 1981. For the year 1982-1983 he is on sabbatical leave at Ecole Polytechnique de Montréal.

Vijay Bhargava is the junior past chairman of the IEEE Montréal Section and is a director of the IEEE Conferences Montréal, Inc. He is a co-vice chairman and the chairman (local arrangements) of the 1983 IEEE International Symposium on Information Theory. He was instrumental in the formation of the Information Theory Chapter in the Montréal Section and currently serves as its chairman. ■

286

259

EVALUACION SUBJETIVA DE METODOS

259

DE CONTROL DE ECO

(A T T)

SATELLITE USER REACTION TESTS
A SUBJECTIVE EVALUATION OF ECHO CONTROL METHODS

Laurence S. DiBiasi
Assistant Manager

Network Services Standards
American Telephone & Telegraph Company

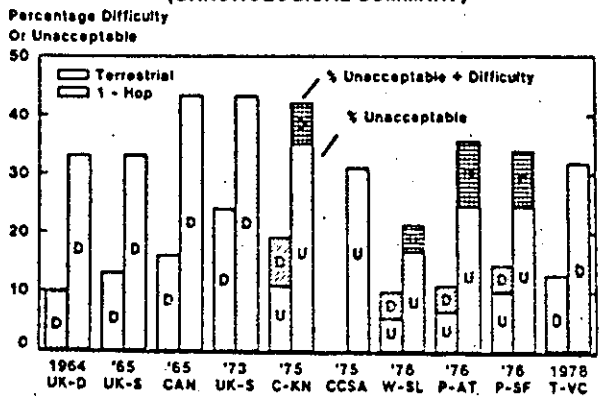
ABSTRACT - This paper provides a composite summary of six Domestic Satellite User Reaction Tests conducted from May 1975 through August 1977. Results from these tests and from earlier experiments consistently show that users experience Difficulty or Unacceptable telephone service two to three times more often on satellite circuits equipped with echo suppressors than they do on conventional terrestrial circuits. Echo cancelers provide sufficient improvement to restore the transmission quality of One-Hop satellite circuits to near-terrestrial performance. The author also demonstrates strong correspondence between users' opinions of transmission quality and their overt actions such as terminating calls early, redialing calls and redialing operators for assistance.

test results are shown for the One-Hop satellite condition only; no terrestrial reference condition was evaluated.

The domestic tests since 1975 also include the percent of calls rated Unacceptable, a more critical category than the rating of Difficulty. In general, customers experienced Difficulty or Unacceptable service on satellite circuits two to three times more often than they did on terrestrial circuits. It is this persistent result which has prompted the Bell System to continue to pursue improved echo control techniques.

Figure 1

SATELLITE USER REACTION TESTS
(CHRONOLOGICAL SUMMARY)



1. INTRODUCTION - Communication satellites have been used for international calls since 1965. More recently, long-distance circuits using satellites as the transmission medium were first used in the continental United States public network in the summer of 1976 when AT&T and GT&E jointly placed the COMSTAR satellite system in service. In 1975, AT&T and Bell Laboratories initiated a continuing series of field tests, using call-back customer interviews, to evaluate user reaction to telephone calls over terrestrial and over domestic satellite (DOMSAT) circuits. Results from these domestic studies and earlier experiments consistently show that users experience a significantly higher level of satisfaction with service via terrestrial circuits as compared with service via satellite circuits equipped with conventional analog echo suppressors.

Figure 1 shows a chronological history of results for ten user reaction tests conducted since 1964. These tests include a range of international and domestic conditions on simulated and on actual satellite facilities. Results are expressed in the percent of calls which are rated unacceptable or in which conversational difficulty is reported. Each test compares the performance of terrestrial circuits with the performance of simulated or actual satellite circuits equipped with analog echo suppressors. The CCSA (Common Control Switching Arrangement)

CHRONOLOGICAL SUMMARY - .KEY

UK-D	US - United Kingdom	Simulated Delay
UK-S	US - United Kingdom	Satellite
CAN	Canadian Domestic	Simulated Delay
UK-S	US - United Kingdom	Satellite
C-KN	Cedar Knolls - Chicago	Simulated Delay
CCSA	CCSA, Pittsburgh - Los Angeles	Satellite
W-SL	Wayne - Salt Lake City	Simulated Delay
P-AT	Pittsburgh - Atlanta	Satellite
P-SF	Pittsburgh - San Francisco	Satellite
T-VC	Toronto - Vancouver	Satellite

2. DOMESTIC SATELLITE TESTS - The six domestic satellite user reaction tests reported in this paper were conducted within the continental United States, (1) including:

(a) A Pilot study using simulated satellite circuits in the public switched network between Cedar Knolls, New Jersey, and Chicago, Illinois, May-June, 1975.

(b) A CCSA network study of Multi-Hop satellite circuits between Pittsburgh, Pennsylvania and Los Angeles, California with access to the public network in Los Angeles, June-October, 1975. (2)

(c) The DOMSAT, Phase O tests on simulated, One-Hop satellite circuits and their terrestrial counterparts between Wayne, Pennsylvania, and Salt Lake City, Utah, March-June, 1976.

(d) The DOMSAT, Phase 1A tests on COMSTAR satellite circuits in the public network between Pittsburgh and Atlanta, Georgia, August-October, 1976. (3) These tests include Terrestrial (VNL Design), Half-Hop* with conventional 4A analog suppressors and new digital echo suppressors and One-Hop circuits equipped with 4A analog suppressors, digital echo suppressors and experimental echo cancelers provided by COMSAT Laboratories and Bell Laboratories. Interviews were conducted at the Atlanta end only.

(e) The DOMSAT, Phase 1B tests on COMSTAR satellite circuits in the public network between Pittsburgh and San Francisco, California, October, 1976 - February, 1977. (3) These tests compare user reaction on different conditions including; terrestrial, half-hop and one-hop circuits equipped with various combinations of echo control devices. Interviews were conducted at the San Francisco end only.

(f) The DOMSAT, Phase 1C tests on COMSTAR satellite circuits, also between Pittsburgh and San Francisco, May-August, 1977. Interviews were conducted at the Pittsburgh end.

3. THE CALL-BACK INTERVIEW - The call-back telephone interview, conducted primarily with the called parties,** contained the following questions which provide a basis for subjective transmission-quality measures:

(a) Was the quality of the connection acceptable to you?

If no, question (b) was skipped.

* Half-Hop circuits are built one way on satellite and one way on terrestrial facilities.

** Nearly all interviews were conducted with the called parties. A small number of interviews were conducted with the calling parties during the Pilot and during the CCSA tests.

(b) Did you have difficulty talking or hearing over that connection?

If the respondent answered "No" to question (a) or "Yes" to question (b), the following question was asked:

(c) Did this cause you or the other person to end your conversation?

If "Yes", questions (d) and (e) were asked.

(d) Did you or the other person call back to complete your conversation?

(e) Did you or the other person contact the operator to inform her of the difficulty or to request assistance?

(f) Which of these four words comes closest to describing the quality of that connection: Excellent, Good, Fair or Poor?

4. COMPOSITE RESULTS - CONVENTIONAL ECHO CONTROL

The results obtained in the six domestic tests are given in Table A and have been combined to form a composite of user reaction as shown in Figure 2 for Terrestrial, Half-Hop, One-Hop and Two-Hop satellite configurations. The composite results are for circuit conditions using VNL design and conventional analog echo suppressors. Customers were engaged in conversations on calls they received in the normal conduct of their daily transactions. They were selected for interview, after completing their calls, by virtue of random traffic selection of the intertoll test circuits.

Results are expressed in terms of the percent of connections which were rated Unacceptable (ZU). Over 6400 customer interviews are included. Of 2414 interviews conducted for the Terrestrial test circuits, 8.3% of the connections are rated Unacceptable. Of 1255 interviews for Half-Hop circuits, 14.9% are rated Unacceptable. For 2005 interviews for One-Hop satellite circuits, 26.0% are rated Unacceptable and of the 753 interviews for Two-Hop satellite circuits, 62.0% or nearly two-thirds of the connections are rated Unacceptable. In general, customers rated the Half-Hop circuits Unacceptable twice as often compared with the terrestrial reference; One-Hop connections are rated Unacceptable three times and Two-Hop connections nearly eight times more often. Figure 3 shows a breakdown of the individual test results which are used to create Figure 2. In addition, Table A gives the Number of interviews (N), percent Unacceptable or having Difficulty (ZU+D), percent Excellent (ZE), percent Good (ZG), percent Fair (ZF), percent Poor (ZP), the Mean Opinion Score (MOS), percent calls Terminated Early (ZTE), percent calls Redialed (ZRE) and percent calls dialed back to Operators for Assistance (ZOA).

Figure 2

Domestic Satellite User Reaction Tests Composite Results

(Using Conventional Echo Suppressors)

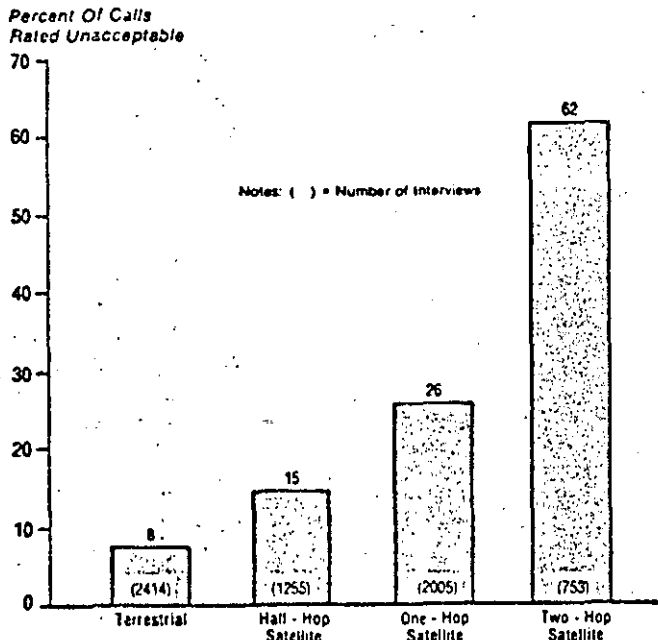
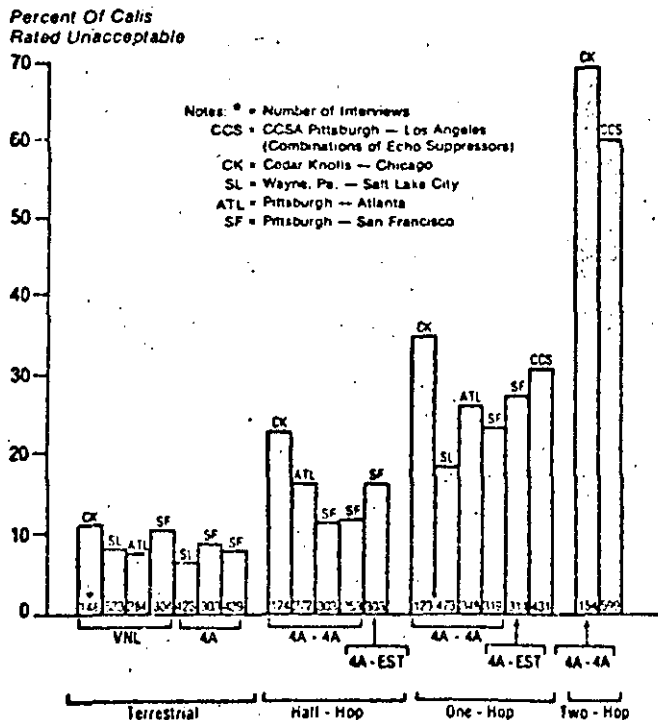


Figure 3

Domestic Satellite User Reaction Tests Individual Results



5. NEW ECHO CONTROL TECHNOLOGY - During the Phase 1 COMSTAR tests, two new echo control devices were evaluated, the #4 ESS digital echo suppressor⁽⁴⁾ and experimental echo cancelers.^{(5), (6)} Table B gives the individual test results as well as the composite calculations. Figure 4 reproduces the composite results of Figure 2 along with the composite results obtained from Table B for the test circuits equipped with the new echo control devices. There are three important findings shown in Figure 4:

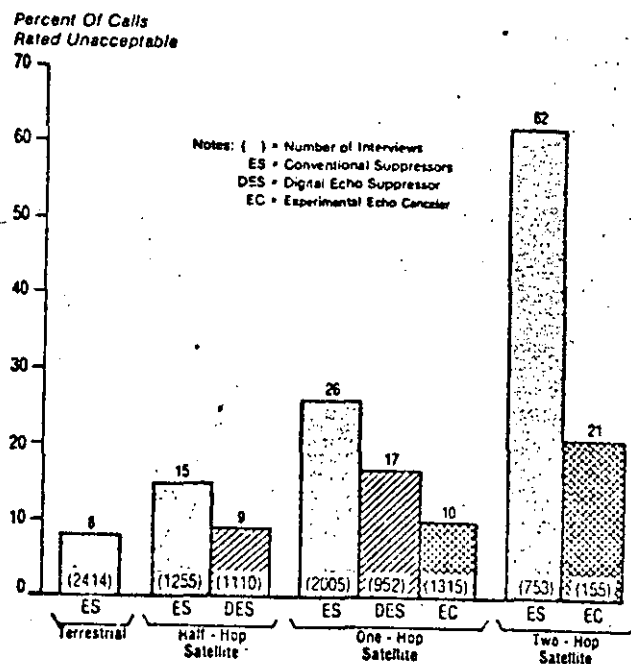
(a) The digital echo suppressor provides service on Half-Hop satellite circuits comparable to terrestrial service (8.7% vs. 8.3% Unacceptable). The digital echo suppressor improves performance on One-Hop satellite circuits when compared with the conventional echo suppressor results (17.3% vs. 26.0% Unacceptable).

(b) The experimental echo cancelers provide service on One-Hop satellite circuits nearly equivalent to the terrestrial results (9.5% vs. 8.3% Unacceptable).

(c) The echo cancelers provide marked improvement in the quality of Two-Hop satellite circuits (21.3% vs. 62.0% Unacceptable). The absolute round-trip delay (nearly 1.1 seconds) appears to be limiting the quality of Two-Hop satellite circuits which can be achieved with echo cancelers.

Figure 4

Domestic Satellite User Reaction Test Results Compares Echo Control Methods

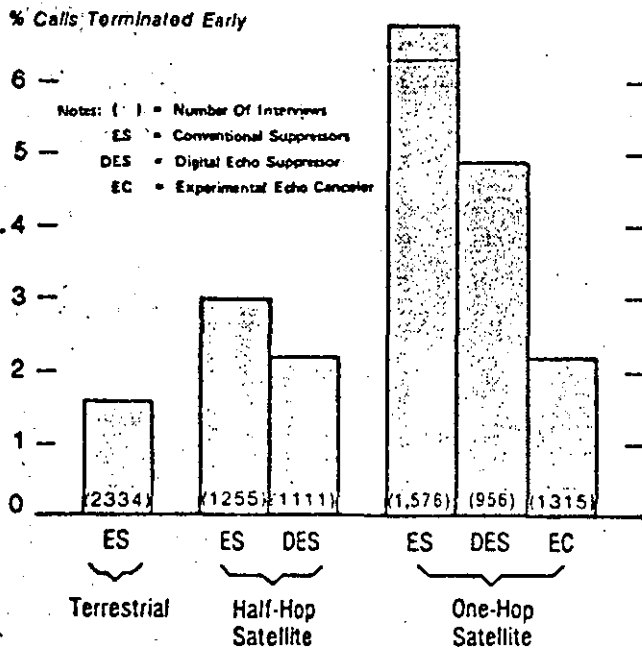


6. CALLS TERMINATED EARLY - Figure 5 displays the composite results for the percent of calls which customers declared were terminated early (Tables A and B). The results for conventional echo suppressors are: 1.6% for the Terrestrial benchmark, 3.1% for Half-Hop Satellite and 6.4% for One-Hop Satellite operation. These results track with the 2:1 and 3:1 ratios of the Unacceptable ratings given in Figure 2. This is a more critical result which implies that customers take some action when they receive poorer quality transmission.

The digital echo suppressor improves performance to 2.1% for Half-Hop and 4.9% for One-Hop satellite operation. The Echo Canceler, with 2.0% of the calls being terminated early, ranks superior to the conventional echo suppressor devices. Due to the small number of occurrences for the terminated early category, the Digital Echo Suppressor on Half-Hop and the Echo Canceler on One-Hop satellite circuits are considered comparable to the Terrestrial performance, consistent with the results in Figure 4 for the Unacceptable ratings.

Figure 5

**Domestic Satellite User Reaction Test Results
Compares Echo Control Methods**



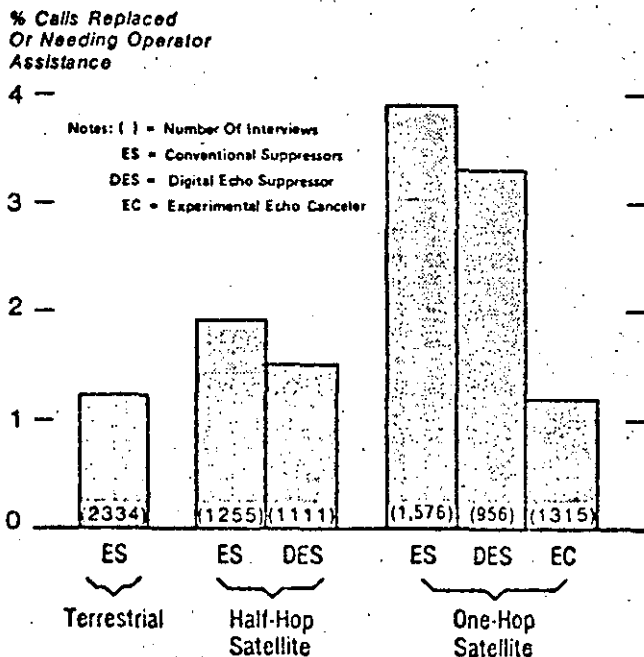
7. CALLS REPLACED OR NEEDING OPERATOR ASSISTANCE
 During the call-back interviews, customers were asked if the call was replaced and, in a separate question, whether or not they needed operator assistance. The results from these two questions have been combined for two reasons: the combined

category represents overt action by customers when they encounter difficulty. The number of occurrences for the separate categories are small and the combined data base gives a better view of the trend. However, it is clear from Figure 6 that the relative performance for Terrestrial, Half-Hop and One-Hop satellite circuits is preserved, consistent with the previous results for Unacceptability and Calls Terminated Early. Half-Hop satellite operation with Digital Echo Suppressors and Full-Hop satellite operation with Echo Cancelers remain comparable to Terrestrial performance.

There are two other important considerations displayed in Table A. First, in the Pilot study, data for the categories of Calls Replaced and Calls Requiring Operator Assistance were gathered from the calling customer. This is a very small data base of 40, 31, 30 and 39 interviews for the TERRESTRIAL, HALF-HOP, ONE-HOP and TWO-HOP conditions, respectively. However, the results for these overt action categories are noticeably higher than in the other experiments. Results in the other tests are predominantly expressed by the called customer, usually not the paying customer. The called customer may not know whether or not the calling customer dialed the operator for assistance. In addition, for the Two-Hop satellite condition in the Pilot test, the User Action is extremely high. For example, of 39 calling party interviews, 10 reported needing operator assistance. Thus, the Pilot results indicate that general user reaction in these more critical categories may be higher than shown, due to the reaction of the paying customer.

Figure 6

**Domestic Satellite User Reaction Test Results
Compares Echo Control Methods**



Secondly, in Tables A and B, the USER ACTION appears highly correlated with the Mean Opinion Score, derived by assigning weights of 4, 3, 2, and 1 to the E, G, F and P ratings, respectively. That is, the USER ACTION steadily increases as the USER OPINION of quality decreases.

8. CONCLUSIONS - The large data base of nearly 10,000 user interviews reported in this contribution demonstrate that:

(a) Telephone users experience Difficulty or Unacceptable service two to three times more often on satellite circuits equipped with analog echo suppressors than they do on conventional terrestrial circuits.

(b) The difficulties experienced by telephone users are primarily due to the effects of controlling echoes in the presence of the long propagation delay inherent in geo-synchronous satellite systems.

(c) It is possible to reduce the impairment effects of delayed echoes to near-terrestrial performance levels using Echo Cancelers on One-Hop satellite circuits. Similar findings have been suggested in previous contributions to CCITT⁽⁷⁾,⁽⁸⁾.

(d) It is possible to improve the quality of satellite circuit performance to comparable terrestrial circuit performance by engineering Half-Hop satellite circuits, using Digital Echo Suppressors. However, this restricts the application of satellites and may not always be practical.

(e) Two-Hop satellite circuit performance can be improved with the use of echo cancelers, perhaps to a quality level similar to that of One-Hop satellite circuits using analog echo suppressors. Performance comparable to that of terrestrial quality is not achieved.

(f) Telephone users steadily increase their overt actions (Terminate Calls Early, Redial Calls or Redial Operators for Assistance) as they encounter poorer quality connections.

ACKNOWLEDGEMENTS - The author is indebted to many associates at AT&T, Long Lines, Bell Laboratories and the Operating Telephone Companies who contributed to the success of the user reaction tests. Special thanks are given to H. F. McCaffrey for his excellent coordination of the field experiments and particularly to Mr. P. C. Lopiparo of Bell Laboratories for his valuable technical contribution throughout the entire series of experiments. Mr. D. L. Duttweiler is primarily responsible for reducing the echo canceler to practical application.

- (1) P. C. Lopiparo, "Results of a Field Study of Domestic - Satellite Transmission Quality," BSTJ, to be published. This paper will provide a comprehensive technical treatment of the domestic test methods and results.
- (2) Federal Communications Commission, Report and Order, File 76-766, August 11, 1976.
- (3) G. K. Helder and P. C. Lopiparo, "Improving Transmission on Domestic Satellite Circuits," Bell Laboratories Record, Vol. 55, No. 8, September, 1977.
- (4) CCITT Study Group XV - Contribution No. 86, (See Annex II to Question 10/XV), January, 1978.
- (5) D. L. Duttweiler, "A Twelve-Channel Digital Echo Canceler," IEEE Transactions on Communication, Vol. COM-26, No. 5, May, 1978.
- (6) See CCITT Study Group XV - Contribution No. 184, (see Annex IV for a discussion of a draft Recommendation for echo cancelers), May, 1978.
- (7) CCITT Study Group XVI - Contribution No. 65, Plenary Period 1973-1976.
- (8) CCITT Study Group XII - Contribution No. 154 (COM XVI - No. 105), April, 1979.

TABLE A - DOMESTIC SATELLITE USER REACTION TESTS - ANALOG ECHO SUPPRESSORS

I.	TERRESTRIAL BENCHMARKS	USER OPINION								USER ACTION			
		N	ZU	ZU+D	ZE	ZG	ZF	ZP	MOS	N	ZTE	ZRE	ZOA
	Pilot	148	10.8	17.6	60.0	25.0	8.0	7.0	3.38	148	1.90	0.90	2.50
	Phase 0-1	523	8.0	11.1	48.2	39.6	6.5	5.6	3.30	441	2.04	1.36	0
	Phase 0-2	423	6.4	6.9	50.2	39.1	7.9	2.8	3.37	425	1.18	0.94	0.47
	Phase 1A	284	7.8	11.3	47.7	41.7	7.1	3.5	3.34	284	1.06	0.70	0.35
	Phase 1B-1	303	9.2	15.2	44.7	36.6	11.2	7.4	3.19	303	2.31	0.99	0.66
	Phase 1B-2	304	10.2	13.8	44.6	38.6	11.0	5.8	3.22	304	1.32	0.33	0.33
	Phase 1C	429	7.9	13.5	53.2	34.7	8.4	3.7	3.37	429	1.40	0.70	0.47
	Composite	2414	8.3	12.1	49.2	37.5	8.4	4.9	3.31	2334	1.58	0.87	0.40

II.	HALF-HOP ANALOG ES	USER OPINION								USER ACTION			
		N	ZU	ZU+D	ZE	ZG	ZF	ZP	MOS	N	ZTE	ZRE	ZOA
	Pilot	124	22.6	28.2	35.0	38.0	14.0	13.0	2.95	124	5.40	5.40	0
	Phase 1A	272	16.2	21.0	41.7	36.4	13.4	8.5	3.11	272	4.41	1.47	0.74
	Phase 1B-1	303	11.6	18.8	33.8	45.7	14.7	5.8	3.08	303	2.31	0.66	0.33
	Phase 1B-2	303	16.5	24.1	28.4	46.8	15.6	9.1	2.95	303	1.32	0.66	0.33
	Phase 1C	253	11.9	19.4	39.9	40.9	12.1	7.1	3.14	253	3.56	1.19	0.40
	Composite	1255	14.9	21.6	35.6	42.2	14.0	8.2	3.05	1255	3.08	1.41	0.43

III.	ONE-HOP ANALOG ES	USER OPINION								USER ACTION			
		N	ZU	ZU+D	ZE	ZG	ZF	ZP	MOS	N	ZTE	ZRE	ZOA
	Pilot	123	35.0	43.1	32.0	28.0	13.0	27.0	2.62	123	14.00	8.60	10.00
	CCSA	431	31.0	-	16.0	47.0	22.0	15.0	2.63	-	-	-	-
	Phase 0	473	18.4	21.4	33.4	40.6	13.6	12.4	2.95	473	4.90	1.69	1.27
	Phase 1A	348	25.9	32.2	32.0	33.9	16.6	17.6	2.80	348	4.60	1.15	1.44
	Phase 1B-1	319	23.5	31.4	26.0	40.6	19.3	14.1	2.79	319	6.90	1.57	0.31
	Phase 1B-2	311	27.6	33.8	23.4	39.2	21.8	15.6	2.70	313	7.35	1.92	0.96
	Composite	2005	26.0	33.6	26.4	39.3	17.8	15.5	2.77	1576	6.44	2.13	1.22

IV.	TWO-HOP ANALOG ES	USER OPINION								USER ACTION			
		N	ZU	ZU+D	ZE	ZG	ZF	ZP	MOS	N	ZTE	ZRE	ZOA
	Pilot	154	69.5	74.7	14.0	16.0	14.0	56.0	1.88	154	43.50	29.6	25.60
	CCSA	599	60.0	-	8.0	27.0	25.0	40.0	2.02	-	-	-	-
	Composite	753	62.0	74.7	8.8	24.7	21.9	44.5	1.99	-	-	-	-

TABLE B - DOMESTIC SATELLITE USER REACTION TESTS - NEW ECHO CONTROL METHODS

I.	HALF-HOP DIGITAL ES	USER OPINION								USER ACTION			
		N	ZU	ZU+D	ZE	ZG	ZF	ZP	MOS	N	ZTE	ZRE	ZOA
	Phase 1A	283	10.2	13.4	49.1	37.5	8.6	4.8	3.31	283	1.77	1.06	0.35
	Phase 1B-1	299	5.4	10.4	41.4	45.1	10.3	3.2	3.25	299	1.67	0.67	0.33
	Phase 1B-2	278	9.4	17.6	42.0	37.9	14.0	6.2	3.16	279	3.23	1.43	0.72
	Phase 1C	250	10.0	14.0	51.2	35.8	9.8	3.2	3.35	250	1.60	1.60	0.40
	Composite	1110	8.7	13.8	45.7	39.3	10.7	4.4	3.26	1111	2.07	1.17	0.45

II.	ONE-HOP DIGITAL ES	USER OPINION								USER ACTION			
		N	ZU	ZU+D	ZE	ZG	ZF	ZP	MOS	N	ZTE	ZRE	ZOA
	Phase 1A	356	16.0	19.9	39.6	39.4	11.9	9.2	3.09	356	5.62	2.25	0.84
	Phase 1B-1	297	19.2	25.9	31.6	41.2	16.0	11.3	2.93	301	4.32	2.66	1.66
	Phase 1B-2	299	17.1	24.1	30.8	43.3	16.0	9.9	2.95	299	4.68	1.34	1.00
	Composite	952	17.3	23.1	34.3	41.2	14.5	10.1	3.00	956	4.92	2.09	1.15

III.	ONE-HOP CANCELER	USER OPINION								USER ACTION			
		N	ZU	ZU+D	ZE	ZG	ZF	ZP	MOS	N	ZTE	ZRE	ZOA
	Phase 1A	334	8.7	12.6	51.8	34.6	7.7	5.9	3.32	334	1.50	.90	0.60
	Phase 1B	464	11.4	17.2	36.5	42.1	15.6	5.8	3.09	464	2.80	.65	0.65
	Phase 1C	517	8.3	13.2	49.4	35.5	11.1	4.0	3.30	517	1.74	.58	0.39
	Composite	1315	9.5	14.5	45.5	37.6	11.8	5.1	3.23	1315	2.05	.69	0.55

IV.	TWO-HOP CANCELER	USER OPINION								USER ACTION			
		N	ZU	ZU+D	ZE	ZG	ZF	ZP	MOS	N	ZTE	ZRE	ZOA
	Phase 1C	155	21.3	29.7	36.7	35.7	13.3	14.3	2.95	155	8.39	3.87	0.65

293

266

ESTANDARIZACION

DE

CANCELADORES

DE

ECO

266

(C C I T T)

ECHO CANCELLER STANDARDIZATION IN THE CCITT*

G. K. Helder
Bell Laboratories, Holmdel, New Jersey

M. Onufry
COMSAT Laboratories, Clarksburg, Maryland

ABSTRACT

Recent technology advances have permitted many innovations in the echo control area. One innovation is echo cancellation. This paper presents the approach taken by the CCITT to produce an echo canceller Recommendation. Highlights of the draft Recommendation are included, specific problem areas are discussed and, for unresolved issues, the points currently being considered are presented.

INTRODUCTION

Advances in solid-state technology have made available a wide range of complex integrated circuit building blocks. These devices have permitted the development of rather sophisticated signal processors which are finding applications in the telecommunications industry. The echo canceller is a recent development which has provided dramatic improvement in echo control in telephone communications [1]-[3]. This paper presents the approach taken in the CCITT to develop a Recommendation for echo cancellers.

The process of standardization within the CCITT consists of the following steps. Near the end of a study period questions are proposed for consideration in the next study period and, if sufficient interest exists, they are incorporated into the scope of work for that period. During the next 4 years member administrations (e.g., British Post Office), operating agencies (e.g., AT&T), and scientific or industrial organizations (e.g., Siemens) submit contributions giving their views in reply to various questions. These contributions are discussed at meetings of Study Groups or smaller working parties, and a consensus of the participants is reflected in a draft Recommendation. If approved at the Plenary meeting of the CCITT, this is published as a numbered Recommendation in the next issue of the CCITT colored books. If all issues cannot be resolved, the Recommendation will contain some provisional items which will remain open for discussion and possible modification in the next study period. Such a process has been used for standardization of echo canceller requirements.

The question proposing the study of echo cancellers was first adopted for study in the 1973-1976 period. However, echo cancellers were still in the research stage, and the question was carried over into the 1977-1980 study period. To date, 14 Contributions have been received and discussed and a draft Recommendation has been prepared.

STUDIES SINCE 1976

Within the CCITT, Study Group XV (Transmission Systems) is responsible for echo control devices. The Echo Suppressor Working Party of Study Group XV is specifically charged with studying questions regarding echo suppressors and echo cancellers. In 1977, the chairman of the Echo Suppressor Working Party (coauthor George Helder) set up a series of meetings with AT&T and COMSAT, two organizations active in echo canceller studies, to discuss the form for a Recommendation on echo cancellers. At that time there existed an echo suppressor Recommendation (G.161) [4] which specified in great detail the operating characteristics of echo suppressors. This form could also be used for echo cancellers. However, it appeared that a more suitable echo canceller Recommendation would address the general functions which a canceller should perform and specify tests which the echo canceller should pass to properly perform these functions. The chairman subsequently prepared such a draft Recommendation as a contribution to Study Group XV (COM XV-No. 96). The contribution was discussed at two working party meetings. Some items requiring additional clarification were identified such as the requirements for transmission performance and compatibility between echo suppressors and echo cancellers used on two ends of the same circuit.

Before the meeting in July 1979, contributions were received on these and other items from Canada (Bell Northern Research) [5], [6], Japan (Kokusai Denshan Denwa) [7], Italy (Italian Administration) [8], and the United States (AT&T and COMSAT) [9]-[11]. As a result of these contributions and the July discussions, extensive revisions were made to the draft Recommendation.

*This paper is based upon the experience of the authors in their roles as delegates to CCITT Study Group XV. Views expressed are not necessarily those of Bell Laboratories or COMSAT Laboratories.

PRESENT FORM OF THE DRAFT RECOMMENDATION

The present draft retains the functional approach to echo canceller specifications. Essentially, on a new telephone connection, an echo canceller should respond to the incoming speech from the far end and its resulting echo, should adapt to the associated echo path in a short time, and should then cancel most of the echo. It should perform this function for essentially any linear, time invariant* (or nearly time invariant) echo path within its memory capacity. In addition, when double talk occurs, the echo canceller must avoid excessive degradation of its echo cancellation performance. Double talk must therefore be detected in the echo canceller and steps taken to prevent further adaptation, which would result in a change from the previous converged state.

DRAFT RECOMMENDATION HIGHLIGHTS

The draft Recommendation, currently designated G.YYY, [12], begins by describing echo cancellers, defining compatibility between echo cancellers and echo suppressors, defining terms associated with echo cancellers, and specifying transmission performance requirements. Tests are then prescribed to measure the functional performance of echo cancellers. The test requirements are all provisional and will require further consideration in the next study period.

The draft Recommendation considers two implementation philosophies. The first implementation (type I) provides cancellation so that the residual echo is at a constant low level regardless of the level of the incoming signal or its echo. In such an echo canceller, an additional nonlinear processing device may be necessary to further reduce the residual echo. The echo canceller must not permit any intelligible echo to be returned to the far talker during the single talk operating mode. A center clipper with a clipping level equal to the peaks of the residual echo has been used for that purpose.

A second implementation (type II) provides cancellation which is constant in dB, regardless of the receive input speech level over a specified dynamic range. In such a canceller, the amount of cancellation may be sufficient to produce acceptably low-level echoes for all incoming speech levels and echo return losses in the telephone network. In this case, additional nonlinear processing may be unnecessary.

Both types of echo cancellers have been used in field trials and both have provided substantial subjective quality improvement over echo-suppressor-equipped circuits. The two implementations are based upon different practical economic/performance tradeoff considerations.

*The present draft Recommendation assumes that the echo path is linear and time invariant and does not address echo cancellers designed to cancel echoes for nonlinear and/or time variant echo paths.

In the type I echo canceller, the center clipper is removed during double talk, thus permitting a low-level echo to pass. Subjectively, in the confusion of double talk, this echo may be perceptible but is not objectionable.

In the type II echo canceller, the highest residual echo level (equivalent to the type I residual echo level) occurs for a combination of poor (i.e., low) echo return loss and high receive speech level. This concept relies upon the low joint probability of occurrence of high receive speech level and poor echo return loss given their independent distributions as observed in the network where the echo cancellers are applied.

TEST CONSIDERATIONS

The tests specified in the draft Recommendation are "black box" tests. Figure 1 shows a typical configuration used for a steady-state test. The tests require minimal knowledge of the internal design of the echo canceller and access to the four I/O ports only. In addition, the need for special test equipment was minimized, and certain external controls, including echo canceller adapt/no adapt, memory clear, and center clipper enable/disable, were assumed.

Test 1 in the draft Recommendation addresses the amount of echo cancellation and specifies that the returned echo level (after cancellation) for a fully converged echo canceller must be below certain bounds. This requirement applies to a range of test signal levels, return losses and end delays. For type I echo cancellers the returned echo level must be ≤ 40 dBm0 (when the center clipper is not enabled); for type II the mask in Figure 2 applies.

The second requirement is that the echo canceller must converge rapidly enough to produce a short and unimportant returned echo at the start of a conversation. Thus, for a range of input signal levels, return losses, and end delays, the echo canceller must achieve sufficient cancellation in 500 ms that the combined loss of the echo path, cancellation, and additional nonlinear loss is > 27 dB. Again, the test signal is noise.

The third requirement is that the echo canceller remain in a converged state during periods of double talk when near-end speech is mixed with the echo. In the test, a simulated double talk noise signal is mixed with the echo at appropriate levels. The requirement specifies that the echo level immediately after the double talking ceases will be no greater than 10 dB above that for the fully converged state.

The fourth requirement is that the echo canceller must converge to an infinite return loss echo path. Echo may be generated as follows. An echo canceller connected to an idle circuit contains the echo path model from the previous connection. If, when a new circuit connection is established, a tandem echo suppressor is encountered in the echo path, the suppression switch will cause the echo canceller to see an infinite echo return loss. If the echo canceller does not converge, it

will now process receive speech through the old echo path model, producing an estimated echo which, when subtracted from the zero circuit echo, will become echo canceller generated echo. For this test the canceller initially converges for a defined echo path, the echo path is interrupted, and a noise test signal is applied to the receive input of the echo canceller. The signal produced by the canceller at the send output is monitored and after a defined time it must be below -40 dBmO.

UNRESOLVED ISSUES

Transmission Requirements

An important aspect in the drafting of recommendations is their economic impact. A recommendation should also be flexible enough to permit future innovations, restrictive enough to guarantee satisfactory performance, and compatible with other recommendations so that it may be treated as a subunit of a larger system with its own overriding constraints.

One subject which has caused considerable discussion in formulating the present draft Recommendation is uniformity of transmission performance requirements for analog and/or digital equipment which may be used on analog and/or digital transmission facilities. This problem is not unique to echo cancellers; it is encountered wherever the two technologies are intermixed in the through transmission path. The four most probable echo canceller transmission facility combinations, identified as types A-D, are shown in Figure 3.

The original philosophy concerning the transmission performance characteristics was quite simple. For the type A and type B echo cancellers, the transmission performance characteristics for echo suppressors given in CCITT Recommendation G.161, *Orange Book*, should apply. For type D, the codec must conform to CCITT Recommendations G.711 [13] and G.712 [14], and in both types C and D, the echo canceller must be transparent, providing bit integrity to single talk signals in either transmission path.

Closer inspection of these relevant Recommendations reveals some problem areas. First, the transmission performance characteristics of Recommendation G.161 are quite restrictive in terms of frequency response and delay distortion. This is relatively insignificant in the design of an echo suppressor, since there is no through path processing, and equipment manufacturers are able to meet the requirements of the Recommendation. For a type A or type B echo canceller, the send path may include decorrelation, a sample and hold, and a reconstruction filter. This extra processing makes it very difficult to economically meet the Recommendation G.161 frequency response characteristic. The problem of meeting the delay distortion requirement is even more severe, perhaps requiring the use of third-order compensating networks.

The benefits of these two transmission performance characteristics may not justify the difficulties involved in meeting them. Further, the negative impact on the network of not meeting these performance characteristics may be small compared to the advantage of using echo cancellers [6], [10].

When transmission requirements are established, the intended application of the device should also be considered. An analog echo suppressor is typically one of many equipment units comprising an analog communications channel. Hence, each piece of equipment should meet stringent transmission requirements to maintain their cumulative effects within acceptable limits. The codec requirements on the other hand, need not be so rigid because it is typically used only once in a digital communications channel. Once the signal is in digital form, it is no longer subjected to the same cumulative effects as analog signals.

Based on these considerations and others, a compromise approach is used which allows for some inconsistent performance characteristics in intermixed analog and digital communications equipment applications. This compromise approach includes the following elements:

a. When an inconsistency is discovered the more stringent requirement is not automatically relaxed to the less restrictive requirement, which could result in unnecessary degradation of the existing network.

b. Similarly, the less restrictive requirement is not automatically tightened to the more stringent requirement, which could impose severe economic consequences.

c. Every attempt is made to maintain the highest possible standards consistent with present operational practice and manufacturing capabilities within each technology.

d. When important differences exist, notes and appropriate references to other Recommendations are used to guide the reader in understanding the potential impact of the characteristic under consideration.

These guiding elements were used to derive the provisional values given for some performance characteristics in draft Recommendation G.YYY. One example is the provisional delay distortion specification, which has been relaxed from the Recommendation G.161 specification but is still considerably more restrictive than Recommendation G.712.

Test Signals and Detectors

A second unresolved issue is the definition of the test signal used to stimulate the echo canceller and the instrument used to measure the resulting response to the stimulus. A widely accepted practice in telecommunications is the use of sine wave test signals. They are simple to use, give repeatable results, are well understood, and can be generated and measured with universally available

equipment. However, a sine wave is not very suitable for testing the performance characteristics of an adaptive echo canceller. That is, the echo canceller is designed to operate on a speech signal and certain properties not present in a sine wave are required for proper behavior of its adaptation algorithm.

Two different test signals have been proposed. The first is a band-limited white noise test signal; the second is noise shaped in accordance with CCITT Recommendation G.227 [15] to simulate speech loading.

Those advocating white noise are concerned that a more complex signal will require additional specialized test equipment for measuring echo canceller performance characteristics. They believe that echo canceller performance measured with band-limited white noise can be specified so that satisfactory performance for speech will be guaranteed. This approach was used in the draft Recommendation.

The advocates of spectrum shaping given by Recommendation G.227 maintain that it gives a more accurate representation of the signals which will be encountered by the echo canceller. Further, they feel that manufacturers of a device which includes spectrum whitening circuitry will be unduly penalized with respect to manufacturers which do not. This is because the measured performance using white noise will be the same, but for shaped noise, the device having spectrum whitening circuitry will yield a higher figure of merit (such as dB of attenuation).

Another item of concern is the weighting factor applied to the instrument used to measure the residual echo. A contribution describing the relative subjective effect of sub-bands of echo within the voice band [16] shows that center band echo is more noticeable than band edge echo. This factor must be properly considered if the purpose is to establish a high correlation between the objective and subjective performance ratings.

Echo Canceller Performance Boundaries

A third area of continuing deliberations, and perhaps the most difficult one to resolve, is the limits on the echo canceller performance boundaries. Typical areas include convergence time, performance under conditions of high-level interfering signals, terrestrial extension range, dynamic response to step changes in the echo path characteristics, and control parameters for nonlinear devices such as center clippers. In all probability, limits for these items will be derived through a combination of laboratory testing coupled with operating experience as different types of echo cancellers are developed and field tested.

CONCLUSIONS

The Echo Suppressor Working Party has produced draft Recommendation for echo cancellers, but it is still subject to approval at the Plenary meeting

to be held in November 1980. This Recommendation contains many provisional areas which will be the subject of future deliberations within the CCITT. Included are the definition of test signals and possibly the measuring instrument, identification of upper and lower limits on the rate of convergence, and dynamic performance characteristics at the start of double talk and in the presence of high-level interfering signals.

It should be noted that the present draft Recommendation is based upon the results obtained primarily from two echo cancellers which have been successfully tested in field trials. The performance characteristics have been defined using a band-limited white noise test signal. The test specifications, even though provisional, do represent a reasonable set of characteristics. If the spirit and intent of the draft Recommendation is followed, it should, in the opinion of the authors, provide an acceptable echo canceller.

REFERENCES

- [1] S. J. Campanella et al., "Analysis of an Adaptive Impulse Response Echo Canceller," *COMSAT Technical Review*, Vol. 2, No. 1, Spring 1972, pp. 1-38.
- [2] H. G. Suyderhoud et al., "Results and Analysis of Worldwide Echo Canceller Field Trials," *COMSAT Technical Review*, Vol. 5, No. 2, Fall 1975, pp. 253-273.
- [3] O. A. Horna, "Echo Canceller Utilizing Pseudo-logarithmic Coding," National Teleconferencing Conference, 1977, Los Angeles, California.
- [4] International Telegraph and Telephone Consultative Committee (CCITT), "Echo Suppressors Suitable for Circuits Having Either Short or Long Propagation Times," Recommendation G.161, *VIIth Plenary Assembly, Geneva, 1976, Orange Book*, Vol. III-1, pp. 80-102, Geneva: International Telecommunication Union, 1977.
- [5] CCITT COM XV No. 307, "Compatibility of Echo Suppressors with Echo Cancellers on Satellite Circuits," BNR/CTCS, April 1979.
- [6] CCITT COM XV No. 307, "Subjective Performance Evaluation of Echo Control Devices on Terrestrial and Satellite Circuits," BNR/CTCS, April 1979.
- [7] CCITT COM XV No. 301, "Some Comments on the Specifications of Echo Canceller," KDD, Period 1977-1980.
- [8] CCITT SG XV, Delayed Contribution CW, "Objective Quality Measures on Echo Cancellers," Italy, 25 June-13 July 1979.
- [9] CCITT SG XV, Delayed Contribution CY, "Satellite User Reaction Tests - A Subjective Performance Evaluation of Echo Control Methods," AT&T, 25 June-13 July 1979.

- [10] CCITT SG XV, Delayed Contribution CZ, "Comments on Preliminary Recommendation G.YYY for Echo Cancellers," COMSAT, 25 June-13 July 1979.
- [11] CCITT SG XV, Delayed Contribution DC, "G.YYY Delay Distortion Specification," COMSAT, 25 June-13 July 1979.
- [12] CCITT SG XV, Temp. Document 73, "Appendix 4 to the Report of the Working Party - Draft Rec. G.YYY - Echo Cancellers," 25 June-13 July 1979.
- [13] CCITT, "Pulse Code Modulation (PCM) of Voice Frequencies," Rec. G.711, *Vith Plenary Assembly, Geneva, 1976, Orange Book, Vol. III-2*, pp. 80-102, Geneva, International Telecommunication Union, 1977.

- [14] CCITT, "Performance Characteristics of PCM Channels at Audio Frequencies," Rec. G.712, *Vith Plenary Assembly, Geneva, 1976, Orange Book, Vol. III-2*, pp. 415-423, Geneva: International Telecommunication Union, 1977.
- [15] CCITT, "Conventional Telephone Signal," Rec. G.227, *Vith Plenary Assembly, Geneva, 1976, Orange Book, Vol. III-1*, pp. 145-147, Geneva: International Telecommunication Union, 1977.
- [16] CCITT COM XV No. 231, "Results of a Subjective Test to Determine the Relative Importance of Talker Echo as a Function of Frequency," British Post Office, February 1979.

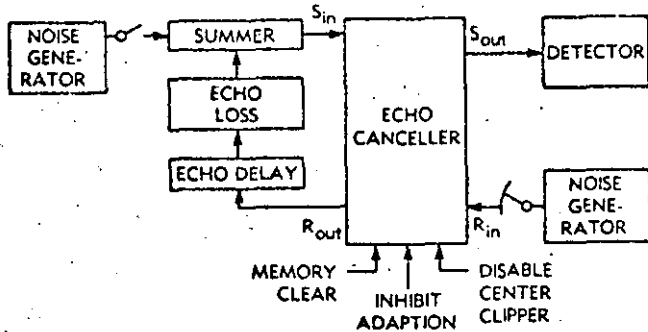


Figure 1. Steady-State Echo Canceller Test Configuration

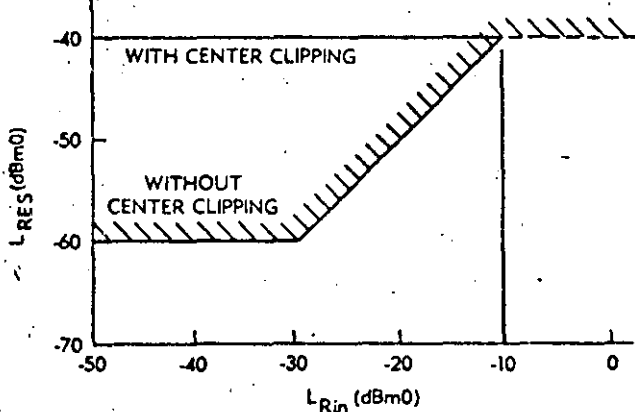


Figure 2. Echo Canceller Steady-State Performance Mask

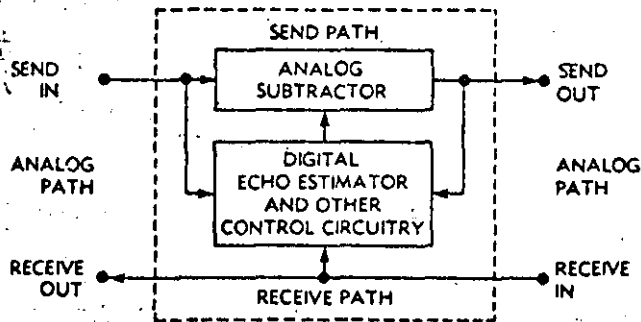


Figure 3a. Type A Echo Canceller

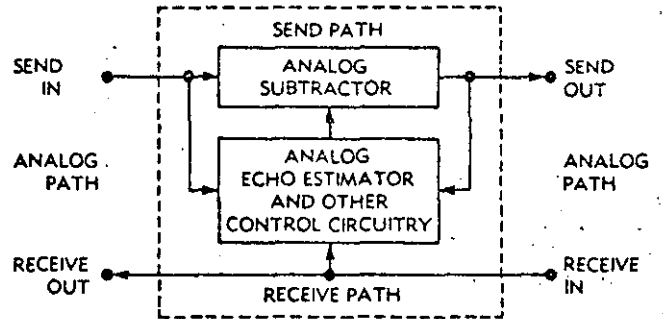


Figure 3b. Type B Echo Canceller

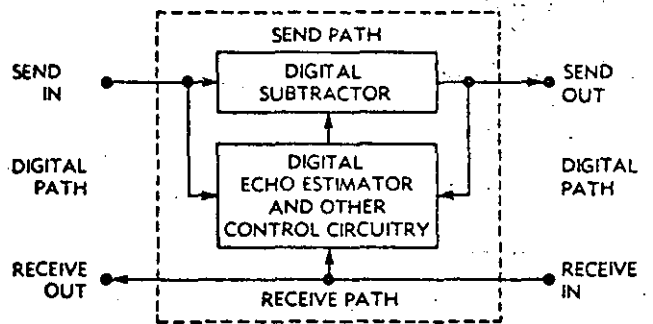


Figure 3c. Type C Echo Canceller

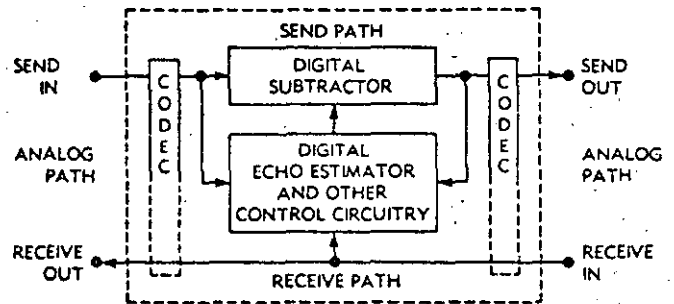


Figure 3d. Type D Echo Canceller

2.9 TÉCNICAS DE CODIFICACION PARA CANALES VIA SATELLITE

En un sistema de transmisión de datos, es deseable incorporar técnicas de codificación dentro de las funciones de los modems, para reducir la razón E_b/N_o requerida para lograr un BER determinado. Esto, sin embargo, reduce la tasa efectiva de la información que puede transmitirse y, por lo tanto, los ahorros en E_b/N_o deben balancearse conjuntamente con la reducción de la tasa de información en un canal limitado en banda ó potencia.

Esencialmente, existen dos variantes de codificación para control de errores:

- Codificación que permite detectar que se produjeron errores en el trayecto de transmisión.
- Codificación que permite detectar y corregir los errores producidos.

En el primer caso, el receptor no es capaz de corregir los errores y tiene que enviar un mensaje al transmisor para que retransmita los paquetes ó bloques detectados con error. Esta técnica se conoce como ARQ (Automatic Repeat Request). Por lo que respecta a enlaces vía satélite, la técnica es poco atractiva debido al retraso que representa el viaje redondo de un cuarto de segundo. Además, se requiere de un sistema de memoria ó buffering para almacenar los bloques ó paquetes temporalmente en caso de que sea necesario retransmitirlos.

En el segundo caso, el receptor utiliza los bits de redundancia para corregir los errores de la transmisión y reconstruir el mensaje original. A la técnica se le conoce como corrección de error por delante ó FEC (Forward Error Correction). Elimina los retrasos en retransmisión y requerimientos de sistemas de

memoria involucrados en la técnica ARQ, y el aumento de complejidad en su implementación no es muy grande. Existen dos tipos de códigos para detección y corrección de errores:

1. Códigos de bloques.
2. Códigos convolucionales.

En la codificación por bloques, el codificador añade bits de paridad a la secuencia de información, entregando a la salida bloques más grandes. La notación empleada para describir estos códigos es (n, k, d_{\min}) , donde n es el número de bits del bloque codificado, k es el número de bits de información, y d_{\min} es la distancia mínima de Hamming entre palabras de código.

Algunos ejemplos de códigos por bloques prácticos son los siguientes:

- a) Códigos de repetición

$$(n, k, d_{\min}) = (n, 1, N), N \geq 2$$

- b) Códigos simplex

$$(n, k, d_{\min}) = (2^k - 1, k, 2^{k-1})$$

- c) Códigos de chequeo por paridad sencilla

$$(n, k, d_{\min}) = (k+1, k, 1), k \geq 1$$

- d) Códigos de Hamming

$$(n, k, d_{\min}) = (2^m - 1, 2^m - 1 - m, 3)$$

- e) Códigos de Hamming extendidos

$$(n, k, d_{\min}) = (2^m, 2^m - 1 - m, 4)$$

- f) Códigos BCH

$$(n, k, d_{\min}) = (2^m - 1, 2^m - 1 - e \cdot m, \geq 2e + 1)$$

La principal característica de la codificación por bloques es que los bits de paridad son agrupados y colocados en una sección definida de la palabra codificada.

En los códigos convolucionales, en contraparte, los bits de paridad son contínuamente intercalados dentro de la palabra codificada. A estos códigos también se les conoce como secuenciales ó recurrentes.

Los sistemas que operan con códigos por bloques requieren elementos de almacenamiento ó memoria para el proceso de codificación y decodificación. En los códigos convolucionales, el proceso de codificación y decodificación es contínuo y no se requieren elementos de almacenamiento ó memoria.

Así como en la codificación por bloques hay diferentes variantes, igual sucede en la codificación convolucional. Algunos ejemplos de las técnicas más comunes de decodificación de esta última son los siguientes:

- a) Decodificación por umbral.
- b) Método secuencial ó probabilístico de Wozencraft.
- c) Algoritmo de Viterbi (decodificación por máxima similitud).

El algoritmo de decodificación de Viterbi por máxima similitud (maximum likelihood decoding) es el que se emplea comúnmente en modems para comunicaciones vía satélite. Entre los principales beneficios que ofrece están:

- La relación E_b/N_0 para una tasa de error ó BER de 10^{-5} , por ejemplo, se reduce aproximadamente de 4 a 6 dB con respecto a la requerida para BPSK ó QPSK sin codificación.

...4

- La estructura del codificador es relativamente simple, y permite operar con tasas de información hasta de 100 Mbps.
- Los requerimientos de coherencia en la fase de la portadora, aún cuando son más exigentes que para BPSK sin codificación, pueden satisfacerse.

Dado que al codificar por cualquier método a una corriente de información, se gana una reducción en el E_b/N_o requerido a cambio de un mayor ancho de banda ó reducción de la tasa efectiva de la información transmitida, lo mismo sucede con la decodificación Viterbi. En los sistemas de comunicación vía satélite generalmente se tienen limitaciones de potencia disponible y no de ancho de banda, por lo que es deseable reducir el E_b/N_o requerido y emplear una técnica eficiente de codificación/decodificación.

Al dispositivo que efectúa el proceso de codificación y decodificación se le denomina CODEC.

Los parámetros más importantes de un codec son la tasa del código y la ganancia del mismo. La tasa del código es una medida de la expansión necesaria en ancho de banda. Por ejemplo, si se tiene ancho de banda extra disponible, ésta puede balancearse con un esquema determinado de codificación y la potencia disponible, para lograr una cierta tasa de bits en error ó BER. Este balance sigue un comportamiento asintótico, en el sentido de que se tiene cada vez menos ganancia por codificación si se usa dos ó tres veces el ancho de banda original. A manera de ejemplo, considérese un sistema con código convolucional de longitud de restricción igual a 7 y con decodificación Viterbi; la ganancia que se obtiene es de 5.1 dB y 5.6 dB sobre PSK coherente, ideal, sin codificación, usando

tasas de código de 1/2 y 1/3, respectivamente, y operando con un BER de 10^{-5} .

En el ejemplo anterior, si la longitud de restricción es 9, se necesita utilizar un 33% más de ancho de banda, y para el mismo BER solamente se obtiene una ganancia de 4.2 dB.

En un enlace vía satélite, la relación total portadora/ruido, C/N, es función de tres relaciones: $(C/N)_{\text{subida}}$, $(C/N)_{\text{bajada}}$, y $(C/N)_{\text{intermodulación}}$. Esta relación total, a su vez, es función de la energía por bit sobre densidad de ruido, E_b/N_o , de acuerdo a la expresión:

$$C/N = (E_b/N_o) \frac{R}{W}$$

en donde R es la velocidad de transmisión, por ejemplo 64 000 bps, y W es el ancho de banda del canal, en Hertz.

No todos los esquemas de modulación son adecuados para la transmisión de datos vía satélite. Los módems más recomendables son BPSK, QPSK, 8PSK y 16PSK. Conforme aumenta el número de fases de la modulación, también aumenta la eficiencia en bits/Hertz, y por consiguiente se reduce el ancho de banda requerido.

Conjuntamente con el tipo de modulación, al haber limitaciones de potencia disponible, habrá que elegir algún esquema de codificación, preferentemente entre codecs con tasa de código de 7/8, 4/5, 3/4, 2/3, ó 1/2.

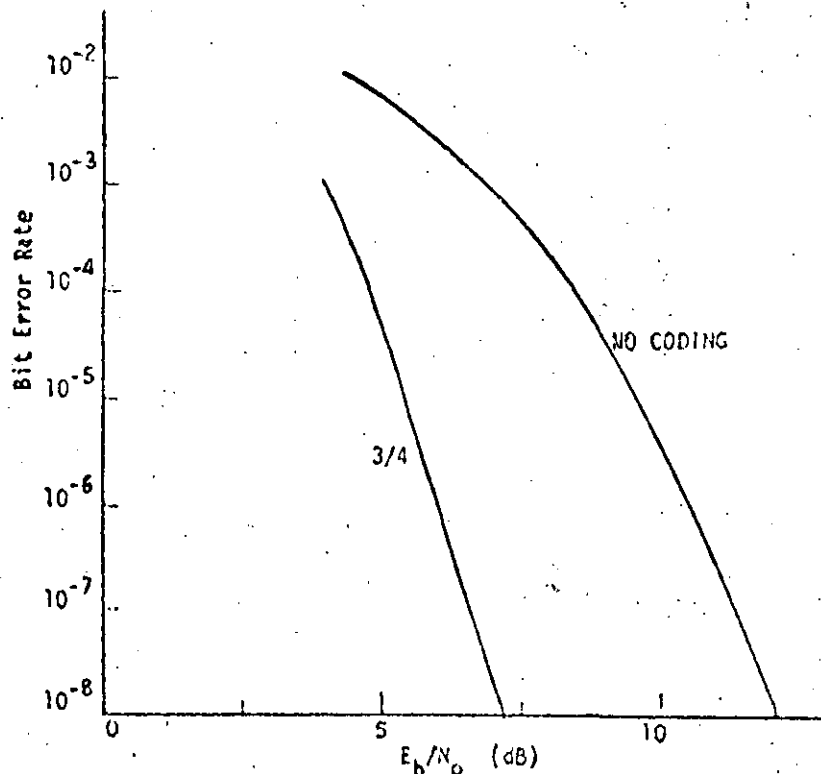
En la Tabla siguiente se muestra, para un BER de 10^{-6} , la ganancia en E_b/N_o y la expansión en ancho de banda que resultan al usar diferentes tasas de código. Los valores indicados para 7/8 y 4/5 se obtienen con decodificación de umbral, y los de 3/4, 2/3 y 1/2 con decodificación Viterbi.

TASA DE CODIGO	1	7/8	4/5	3/4	2/3	1/2
GANANCIA (dB)	0	2.55	3.80	4.39	4.77	5.40
EXPANSION EN ANCHO DE BANDA	1	1.14	1.25	1.33	1.5	2

Se ha demostrado que en sistemas donde se tiene poca potencia disponible, las mejores combinaciones de modulación/codificación son BPSK ó QPSK con tasa de código de 3/4, 2/3, ó 1/2.

En aquellos casos en los que se tengan limitaciones de ancho de banda, y no de potencia, es preferible utilizar por ejemplo 8PSK ó 16PSK con tasas de código de 7/8 ó 4/5.

En la gráfica siguiente se muestra el E_b/N_0 requerido sin codificación y con codificación de 3/4 para lograr una tasa de error ó BER determinada.



Ejemplos de sistemas disponibles en el mercado.

a) DIGITAL COMMUNICATIONS CORPORATION.

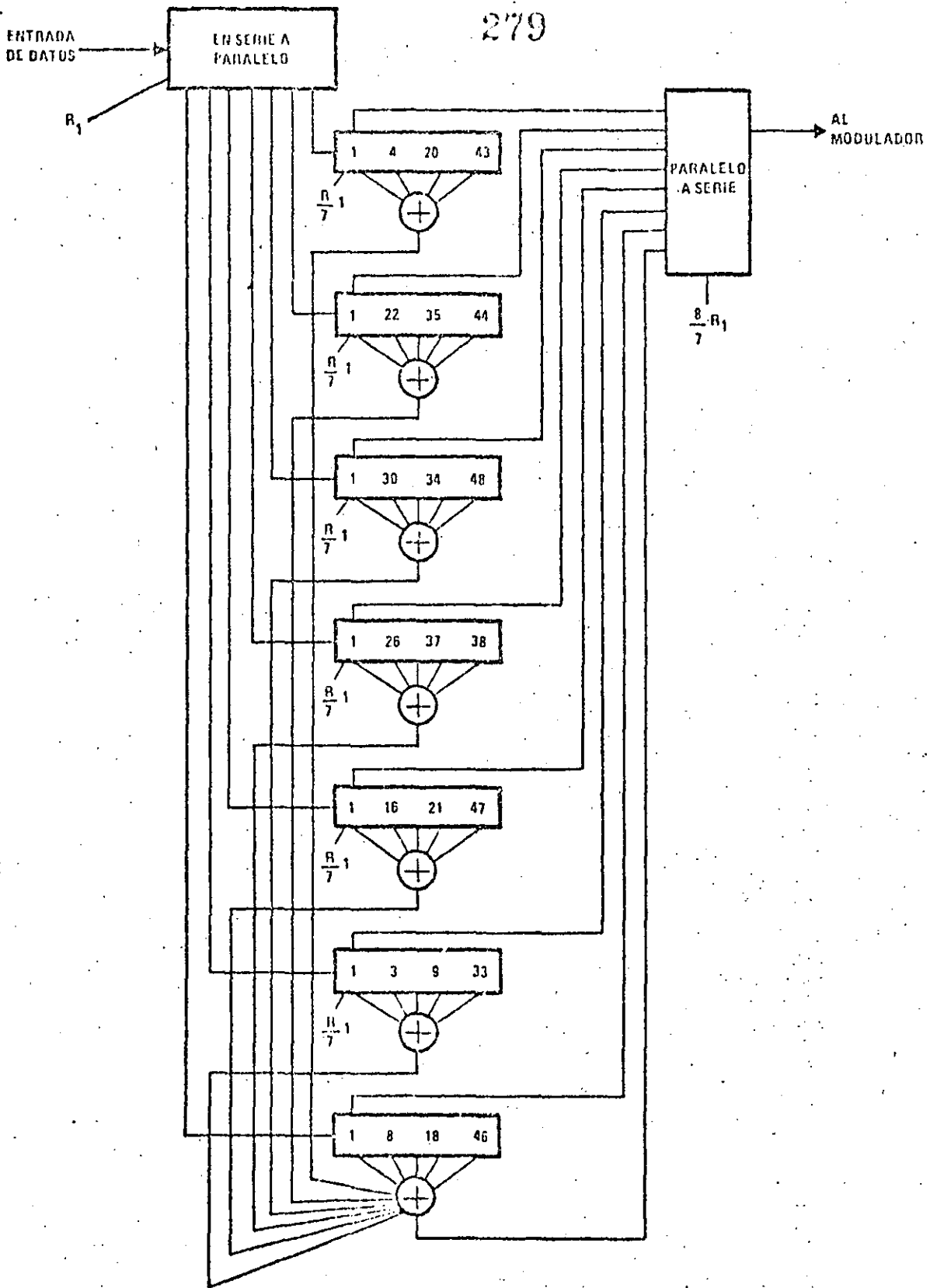
Esta compañía ofrece una serie de estaciones terrenas denominadas DYNAC, para la transmisión de paquetes con datos y voz digitalizada (TDM) por medio de acceso múltiple por división en el tiempo (TDMA). Las estaciones emplean multiplexores estadísticos y las tasas de transmisión pueden seleccionarse desde 268 Kbps hasta 2 Mbps.

La modulación empleada es QPSK y la codificación es del tipo FEC, con tasa de código de 1/2. Ofrecen codecs opcionales con tasas de código de 7/8 y 3/4.

b) HARRIS CORPORATION

Esta compañía ofrece, entre otros componentes, su modem modelo 7005 (LRDM - Low rate data modem) que convierte las señales digitales entrantes a una portadora modulada en BPSK. La tasa del código convolucional empleado es de 7/8 con decodificación de umbral, y la ganancia del codec es de aproximadamente 2.5 dB.

El diagrama de bloques conceptual del codificador de relación 7/8 se muestra en la figura siguiente. El codificador acepta una corriente de datos de entrada en serie y realiza una conversión de serie a paralelo en siete corrientes de datos. Las corrientes de datos se desplazan a través de siete registradores de datos, según el algoritmo de codificación utilizado. Las salidas de las 7 etapas se suman a base de módulo 2 para



Codificador Ortogonal Automático de 7/8

HARRIS

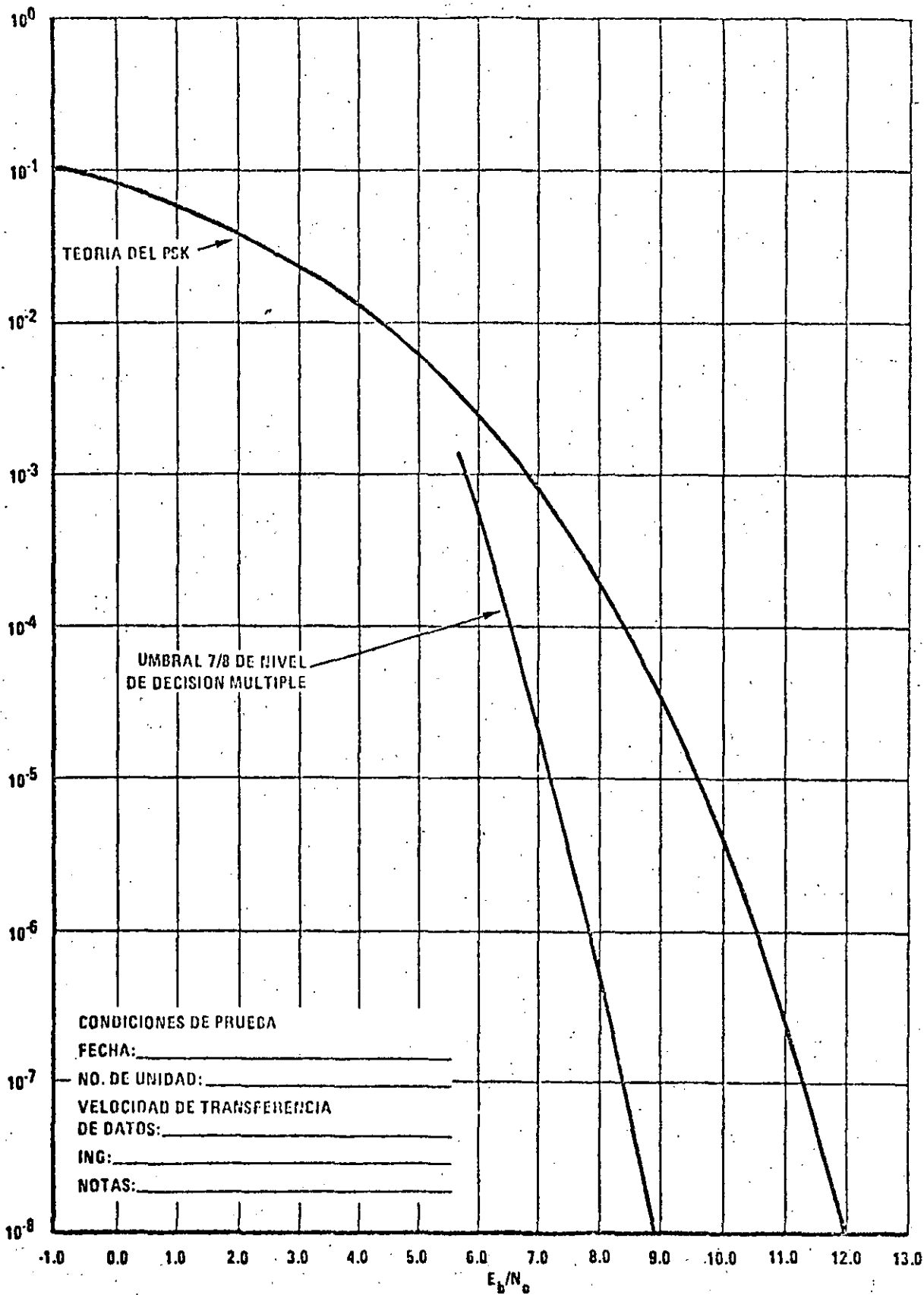
...8

generar el bit de paridad. Los siete canales de datos se recombinan junto con la secuencia de paridad para generar la corriente de datos de salida que entra al modulador.

A continuación se muestra el desempeño del codec de decisión de umbral de 7/8 en comparación con la razón E_b/N_o teórica para PSK sin codificación.

c) TELESYSTEMS

Esta subsidiaria de COMSAT produce una terminal para acceso múltiple por división en el tiempo (TDMA), modelo DST-1000, que puede ser usada en redes privadas y públicas con ráfagas de 15 a 60 Mb/s, con capacidad hasta 100 estaciones por red. El modem de la terminal es QPSK, y emplea codificación por bloques del tipo Hamming con tasa de código 4/5. Se anexa copia del catálogo descriptivo.



"Soft" Codec de Umbral 7/8

HARRIS

Referencias.

- 1.- "Communication Systems", A. Bruce Carlson, McGraw-Hill, sección 10.3.
- 2.- "Digital Communications by Satellite", James J. Spilker, Jr., Prentice-Hall, capítulo 15.
- 3.- "Chien, R.T., "Block coding techniques for reliable data transmission", IEEE Trans. Commun. Technology, Vol. COM-19, pp. 743-751, October 1971.
- 4.- Viterbi, A.J., "Convolutional codes and their performance in communication systems", IEEE Trans. Commun. Technology, COM-19, pp. 751-772, October 1971.
- 5.- Lucky, Salz and Weldon, "Principles of Data Communication", McGraw-Hill, capítulos 11 y 12.

310²⁸³

TERMINAL

DYNAC

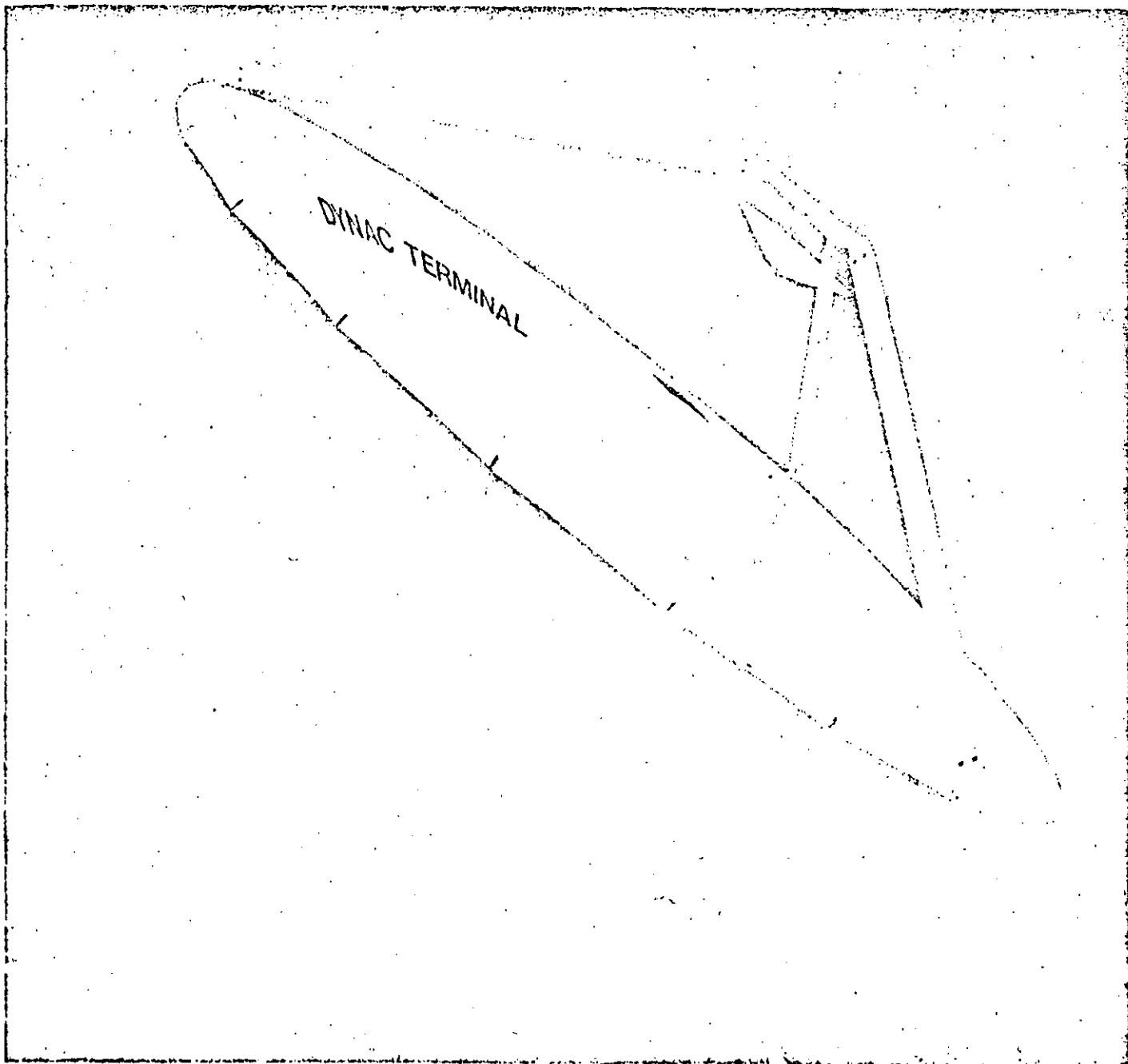
283

TDM - TDMA

DYNAC™

311 284

INTELLIGENT
EARTH
STATION
TERMINALS



via TDM (continuous) broadcast transmission to all remote sites. Communication in the return path, i.e. from all remote sites to the central, is via TDMA. The STAR network uses a TDM/TDMA carrier pair. Note that remote-to-remote communications is via data routing through the central site. Such an interconnection requires a double satellite hop.

The MESH network uses the same terminal equipment as the STAR, but is a fully-connected network utilizing a single TDMA carrier. No central site exists, but one site is designated as the reference site, which provides network management, burst control and synchronization.

For fixed assigned, low density traffic requirements, SCPC can also be implemented.

Key Features

A. Dynamic Assignment

Based upon real-time requirements, satellite bandwidth is allocated to each station in the network, which allows unused capacity to be reassigned upon demand. Several network management algorithms can be used to determine how capacity shall be assigned. The central (or reference) site communicates signaling information to each station in the network, and reconfigures the network connectivity automatically. A terminal operator may also manually request or assign a capacity change.

B. Overhead Signaling Channel

The signaling channel used for network status and control is part of the transmission frame overhead. This duplex channel provides for remote control commands, network reassignments, requests and assignments, and fault monitoring and reporting. All command/control is handled via a microprocessor controlled unit, the Intelligent Terminal Interface (ITI).

C. Auto-Diagnostics and Fault Reporting

The ITI monitors all station fault indications and performs automatic status reporting to the central site. Remote diagnostics can also be performed, such that unmanned stations can be remotely controlled, various loopback functions performed, and test routines exercised.

In addition, the ITI can support a local maintenance terminal and has auto-dial modem capability, allowing for remote diagnostics to be performed without having a satellite path established.

D. Data Concentration

Two levels of concentration are realizable using the dynamic assignment technique. First, bandwidth may be allocated via time slot assignment on a port-by-port basis, at any of the rates shown in *Table 1*: Channel ports may be set up and disabled either manually, automatically upon terminal request, or by time-of-day control via the Network Management System (NMS). Bandwidth not allocated is returned to a "pool" from which it can be reassigned (similar to a DAMA system in FDMA networks).

Secondly, bandwidth may be varied within an assigned channel port in real-time, based upon an instantaneous requirement. Such a scheme is illustrated in *Figure 2*, which shows a statistical multiplexer supporting a variety of data terminals and supplying a multiplexed synchronous serial

The DYNAC™ series of satellite earth stations provide unique integrated communications packages designed for multiple access digital data/voice transmission. The earth stations offer maximum flexibility and statistical multiplexing with a selection of transmission rates from 268 kbps to 2 Mbps, a variety of digital and analog interfaces and microprocessor station control.

Implementation of a complete satellite communications network is afforded via the inherent features of the DYNAC™ series earth stations. The network architecture includes mixed data and voice traffic, centralized network control, incremental growth, unattended operation and phased transition from fixed assigned to dynamic assigned operation.

Network Configurations

The DYNAC earth station employs Time Division Multiplex (TDM) and Time Division Multiple Access (TDMA) techniques, and includes real-time dynamic allocation of transmission bandwidth. The combination of these features provides highly efficient space segment utilization and reduced system hardware costs.

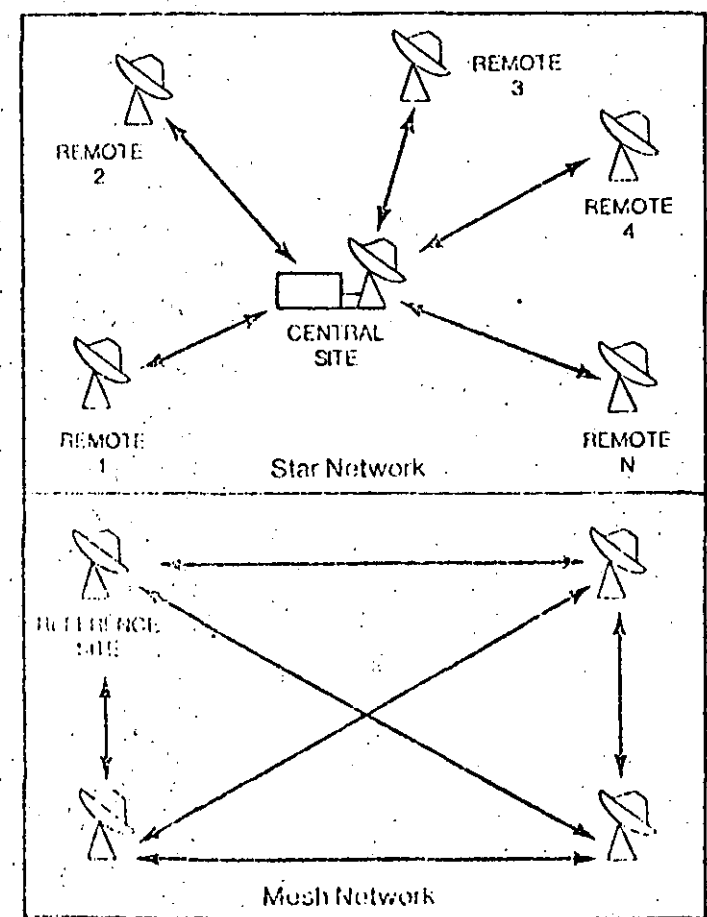


FIGURE 1

Network Configurations

The DYNAC earth station is used in both STAR and MESH network configurations, as shown in *Figure 1*. A STAR network involves a central site that communicates

data stream to the DYNAC channel port. The buffer occupancy status of the statistical multiplexer is sent via an asynchronous out-of-band interface to the ITI, which relays this information via the signaling channel to the AS.

The status is interpreted as a request for more (or less) bandwidth, and a new network plan is generated. All sites that may be affected are reassigned a new network plan consisting of channel port rate assignments and TDMA burst position. When the network reassignment is completed, the low speed clock for the affected port is changed to reflect the new rate. Dynamic assignment of bandwidth within a port extends the statistical multiplexer bandwidth advantages through the complete communications link.

300 baud
600 baud
1.2 kbps
2.4 kbps
4.8 kbps
9.6 kbps
19.2 kbps
32.0 kbps (voice)
56.0 kbps

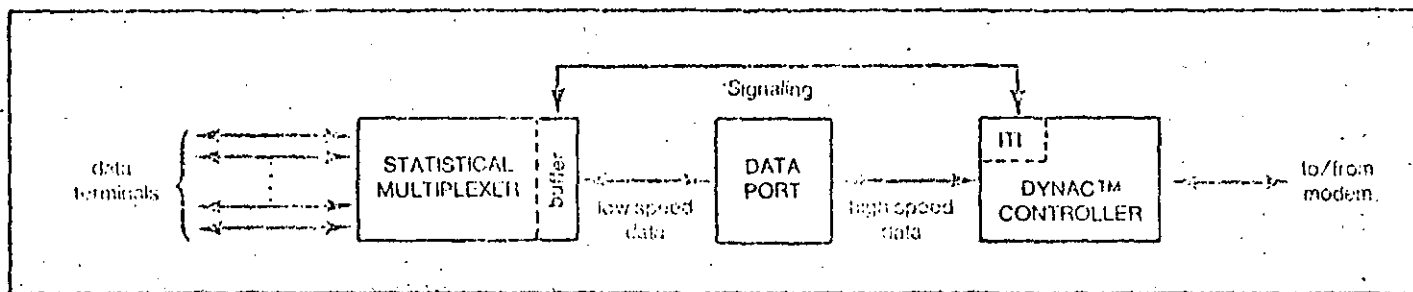


FIGURE 2

Statistical Multiplexer Interface

E. TDMA Burst Synchronization

Burst positions for all earth stations accessing the TDMA frame are assigned by the NMS. Slant path differentials between sites (depending upon the geographical locations of the sites) is known apriori, hence is accounted for in the burst position assignments.

It is necessary to allow for a guard time of sufficient duration between the bursts to preclude the possibility of bursts overlapping at the satellite, due to the doppler shift encountered with the figure-eight motion of the satellite (over one sidereal day). The DYNAC earth station employs open-loop burst synchronization during acquisition, which allows for this minimum guard time (approximately 300 microseconds) in the determination of burst assignments. In steady state (acquired) operation, burst positions are adjusted by the local station to minimize guard times. The scheme is extremely simple and has negligible impact on frame efficiencies at transmission rates below 2 Mbps.

All stations in the network are assigned their transmit burst positions relative to the broadcast reception of the REFERENCE UNIQUE WORD, which is transmitted by the central (or reference) site and denotes the beginning of the TDMA frame.

F. Selectable Frame Lengths

Frame lengths are selectable from 10 to 250 milliseconds duration. Larger frame lengths yield slightly higher bandwidth efficiencies, while shorter frame lengths are used where the transmission delay between interactive terminals is a major consideration.

G. Modularity

All components of the DYNAC earth station has been designed to be accessible from the front of the equipment

ules, which are accessible from the front of the equipment tray by removing a plexiglass front panel. Test points, indicators and controls are located behind the front panel at the front of the circuit cards, facilitating ease of maintenance and test.

The IF/RF frequency converter, which is housed in a stand-alone chassis, uses stripline technology for high reliability and compact design. A removable plexiglass front panel allows access to test points. All internal assemblies are easily removable providing for ease of maintenance.

Typical Link Performance

Table 2 presents link performance summaries for two cases of a MESH configuration. Case 1 is a 537.6 kbps

Item	Value		Units
	Case 1	Case 2	
Frequency (MHz) (Down, nom)	5	5	megahertz
Frequency (MHz) (Up, nom)	22.0	22.0	dB, °K
ITN (dB)	14.1	14.1	
Transmitted Output Power	40	125	watts
Received Power Per Carrier	20.4	60.2	watts
ERP Per Carrier	50.8	62.3	dBw
Modulation	4-Q PSK	4-Q PSK	
Transmission	TDMA	TDMA	
Main Channel Rate	537.6	1,612.8	kbps
Channel	Rate 1	Rate 2	
Channel Noise Power (dB)	20.2		dB
Channel Noise Power (dB)	13.5		dB
Total Channel Efficiency		12.2	dB
Received Power (dB)	0.5		dB
Channel Noise Margin	22.4		dB

TDMA network with all stations having a 22.0 dB/K G/T and transmitting via 40 watt TWT amplifiers. Case 2 is a 1.6128 Mbps TDMA network with the same earth station G/T and operating with 125 watt TWT amplifiers. Rate 1/2 coding is used in both cases with a threshold BER re-

quirement of 10^{-6} assumed. The LNA noise temperature is 120° K, and the antenna diameter is 5 meter (nominal).

Modulation 287

The modulation technique employed is quadrature phase-shift keying (QPSK) with transmission rates to 2.048 Mbps. Standard modem rates are shown in Table 3 and have been chosen to permit a simple baseband clock regeneration scheme.

Error Coding

The DYNAC controller contains a Rate 1/2 Forward-Error-Correction (FEC) codec that is field selectable.

Rate 7/8 hard decision or Rate 3/4 soft decision FEC codecs are also available. Specific network requirements determine the applicability of these codecs.

Standard QPSK modem transmission Rates

- 266.8 Kbps
- 537.6 Kbps
- 1.544 Mbps*
- 1.6128 Mbps
- 2.048 Mbps*

* These rates do not support 56 Kbps data port operation

TABLE 3

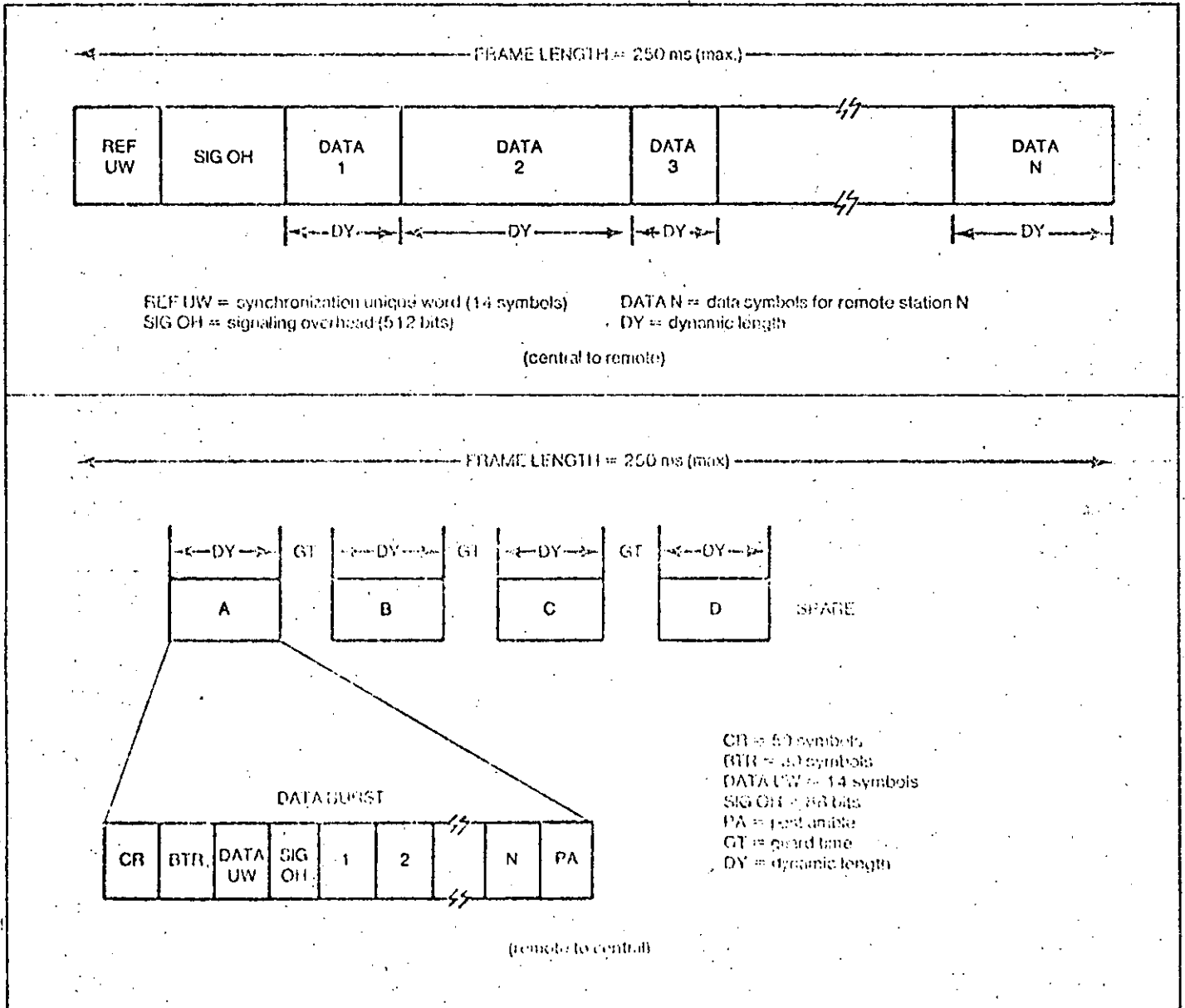


FIGURE 4
 Frame Formats (Star Network)

The frame format selected depends on the network configuration. *Figure 4* presents the formats used for the STAR network. Since transmission from the central station to the remotes is continuous (TDM), the format used is different than that for the remote stations (TDMA). Network synchronization is achieved via the Reference Unique Word in the TDM frame. *Figure 5* illustrates the frame format for the MESH network. Network synchronization is achieved via the REF UW contained in the reference station burst. In both cases, the frame length is dependent on the traffic requirements of the network.

The Carrier Recovery/Bit Timing Recovery (CR/BTR) sequence present at the beginning of each TDMA burst is required to provide for carrier and symbol timing acquisition of the burst demodulator. The CR/BTR sequence is followed by the unique word (UW) which is used to denote

the first valid information bit in the burst. The reference unique word is used for frame synchronization as well.

The signaling overhead is the duplex command and control channel used for signaling between DYNAC earth stations and the central site. The outbound (central to remote) channel consists of 64 bytes of information per frame; each inbound (remote to central) channel consists of 11 bytes.

Data blocks for each assigned data port at the terminal are of different lengths, depending upon the rate assignment. Each port is assigned independently, and can operate transmit and receive sides at different rates as well. The time slot (block) for each port is assigned dynamically.

The postamble (PA) is required whenever a FEC codec is used, so that parity bits may be flushed from the error decoder.

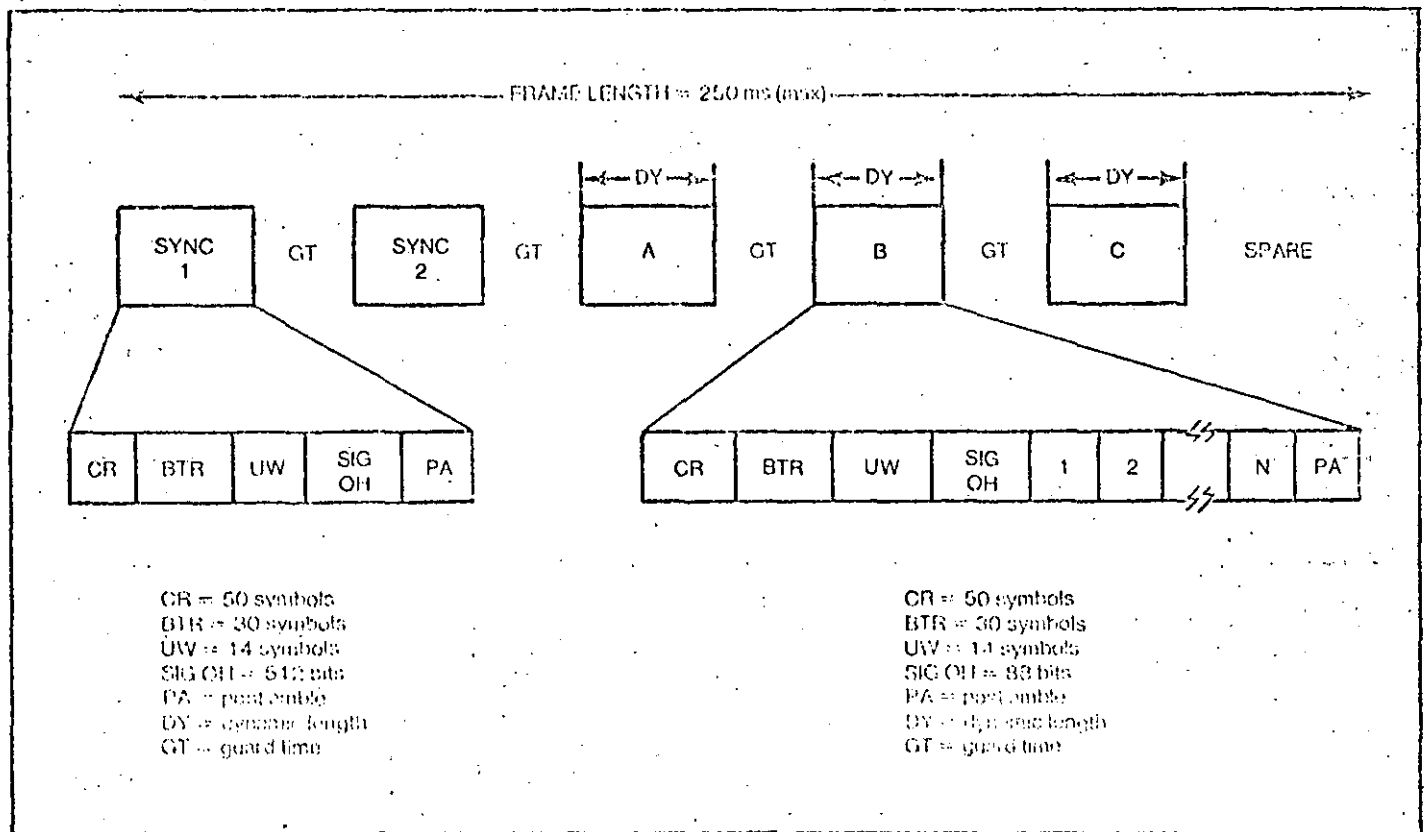


FIGURE 5
Frame Format (Mesh Network)

Terminal Operation

The DYNAC™ earth station is composed of two major subsystems. The first is the IF/RF Subsystem which includes the earth station antenna, low noise amplifier, power amplifier, and frequency converters. The second is the Digital Processing Subsystem which includes the control software and digital baseband hardware. These two major subsystems as well as their individual components are illustrated in *Figure 6* (nonredundant configuration). The operation of the system is described below.

IF/RF Subsystem

The IF/RF subsystem provides the interface between the digital processing subsystem and the satellite. Such interface requirements include the necessary frequency up conversion and power amplification of the outbound QPSK modulated IF carrier as well as the low noise reception and down conversion of the inbound 4 GHz signals from the satellite.

The antenna subsystem consists of a parabolic reflector, a specially shaped subreflector for Cassegrain operation, and the antenna feed assembly.

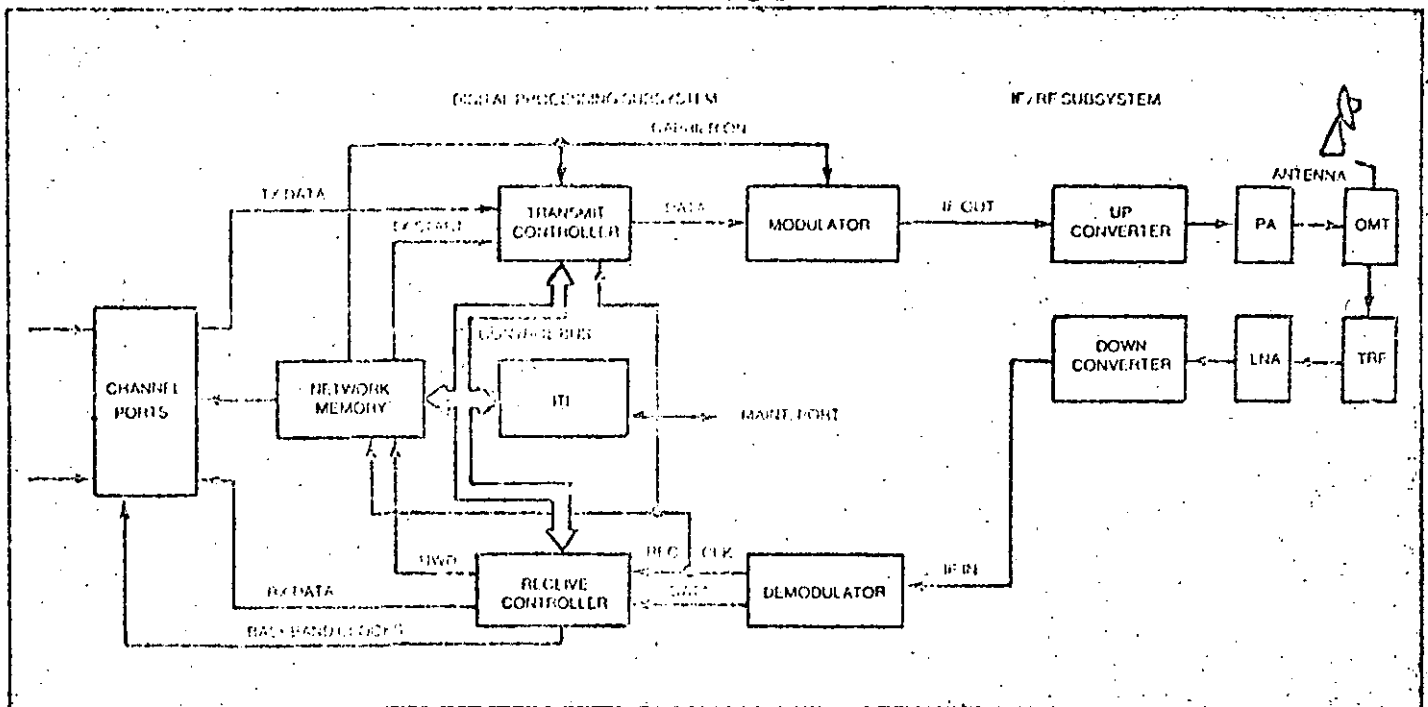


FIGURE 6
DYNACT™ Terminal Block Diagram (non-redundant)

and a manually adjustable mechanical mount. The parabolic reflector and complementary subreflector combined with the dual linearly polarized feed provide high gain and low sidelobe characteristics in the frequency bands of 3.7-4.2 GHz and 5.925-6.425 GHz. The simultaneous transmission and reception of the orthogonally linear polarized signals in the two frequency bands is accomplished via an orthomode transducer (OMT). The OMT is part of the feed assembly and is basically a frequency and polarization selective device.

On the receive side, the 4 GHz signal from the antenna subsystem passes through a transmit reject filter (TRF). The TRF protects the low noise amplifier from the high level 6 GHz signal, being transmitted. The receive signal is then passed through a low noise amplifier (LNA). The low noise properties of this amplifier coupled with its high gain set the noise figure of the receive system. The amplified output of the LNA then passes to the down converter where the 4 GHz signal is translated to a nominal 70 MHz IF frequency. It is this signal which interfaces with the Digital Processing Subsystem.

On the transmit side, the Digital Processing Subsystem supplies a QPSK modulated signal at the nominal 70 MHz IF frequency which is fed into the up converter. This signal is then translated to 6 GHz, amplified by the high power amplifier (HPA) and fed to the antenna. It is important to note that the frequency conversion performed by the up and down converters is done on a transponder basis. Channelization within a transponder is accomplished within the Digital Processing Subsystem.

Digital Processing Subsystem

On the transmit side, synchronous digital data (from any of several channels) is converted to a serial stream and

written into compression buffers of the channel ports by the assigned low speed clock. The compression buffers serve to rate change the continuous low speed data to the high speed rate. The high speed data is gated from the compression buffers under control of the Transmit Network Memory which has been programmed by information "down-line" loaded from the Network Management System (NMS). The gating information is the network plan that also controls carrier on/off times, preamble generation, and the overhead signaling channel.

Data from all channel ports is multiplexed onto the high speed data bus and fed into the transmit TDMA controller, which adds the modem preamble, signaling channel, and postamble (if applicable), then scrambled with a PN sequence to ensure uniform spectral spreading prior to transmission.

The QPSK modulator accepts the two symbol streams (A and B data) and quadrature-phase modulates an IF carrier with this information. The modulated carrier is gated for transmission under direction of the TDMA controller.

The operation of the receive circuitry is similar to the transmit side. The input QPSK carrier is demodulated and the receive data is synchronized to the appropriate unique word detection (UWD). Descrambling and Rate 1/2 decoding (if applicable) of the data is synchronized to the UWD. Signaling data is demultiplexed from the high speed data stream and sent to the Intelligent Terminal Interface (ITI) for further processing. The remainder of the high speed data is selectively gated into the assigned channel ports under control of the Receive Network Memory. Expansion buffers within the channel port restore the high speed data to the low speed continuous rate. Baseband clocks are provided, on both sides, being generated from a common source.

At the heart of the digital processing subsystem is the ITI which performs several key functions. First, all status and alarm information is relayed via the ITI to the NMS location for remote monitoring. Secondly, bandwidth requests and acknowledgements, network plan assignments, update commands, and control information are processed by the ITI. All of the above information is contained in the overhead signaling data. Via the NMS, complete access to the status and control of all remote DYNAC™ terminals is provided for unmanned operation of these sites. Automatic control (port assignment and "down-line" loading) of the entire network can be accomplished through the use of the ITI and its associated overhead channel.

Redundancy

The DYNAC earth station equipment is available in redundant or non-redundant configurations. For a redundant site, all IF/RF transmission hardware is provided with 1:1 redundancy and automatic switchover. The DYNAC baseband common equipment is also provided with 1:1 redundancy and auto switchover. Channel port modules are provided with two independent control and data bus interfaces, so that they can be controlled by either on-line system, electrically independent of the other, thus avoiding the possibility of a catastrophic failure. *Figure 7* shows the redundant configuration.

Reference site redundancy is provided by using primary and secondary reference bursts. Either site provides network synchronization, and upon loss of the primary site, the secondary site establishes network control.

Expansion 290 317

The baseband equipment may be expanded to provide a variety of channel port interfaces. Up to 40 channel ports may be connected at any earth station site. Five ports may be contained in the start-up tray (containing the DYNAC common equipment), and expansion chassis holds up to ten additional ports. The expansion tray contains provisions for redundant power supplies and control busses.

When the space-segment capacity requirements of the network are exceeded, the baseband equipment can be configured to allow for IF (intermediate frequency) hopping. A Channel Select Oscillator (CSO) module provides independent local oscillator references for the modem, and is controlled by instructions down-line loaded into the Network Memory. The station is then capable of transmitting and/or receiving multiple TDMA bursts per frame on different carrier frequencies, hence the network capacity is increased without the addition of baseband equipment, and most importantly without changing the earth station G/T requirements.

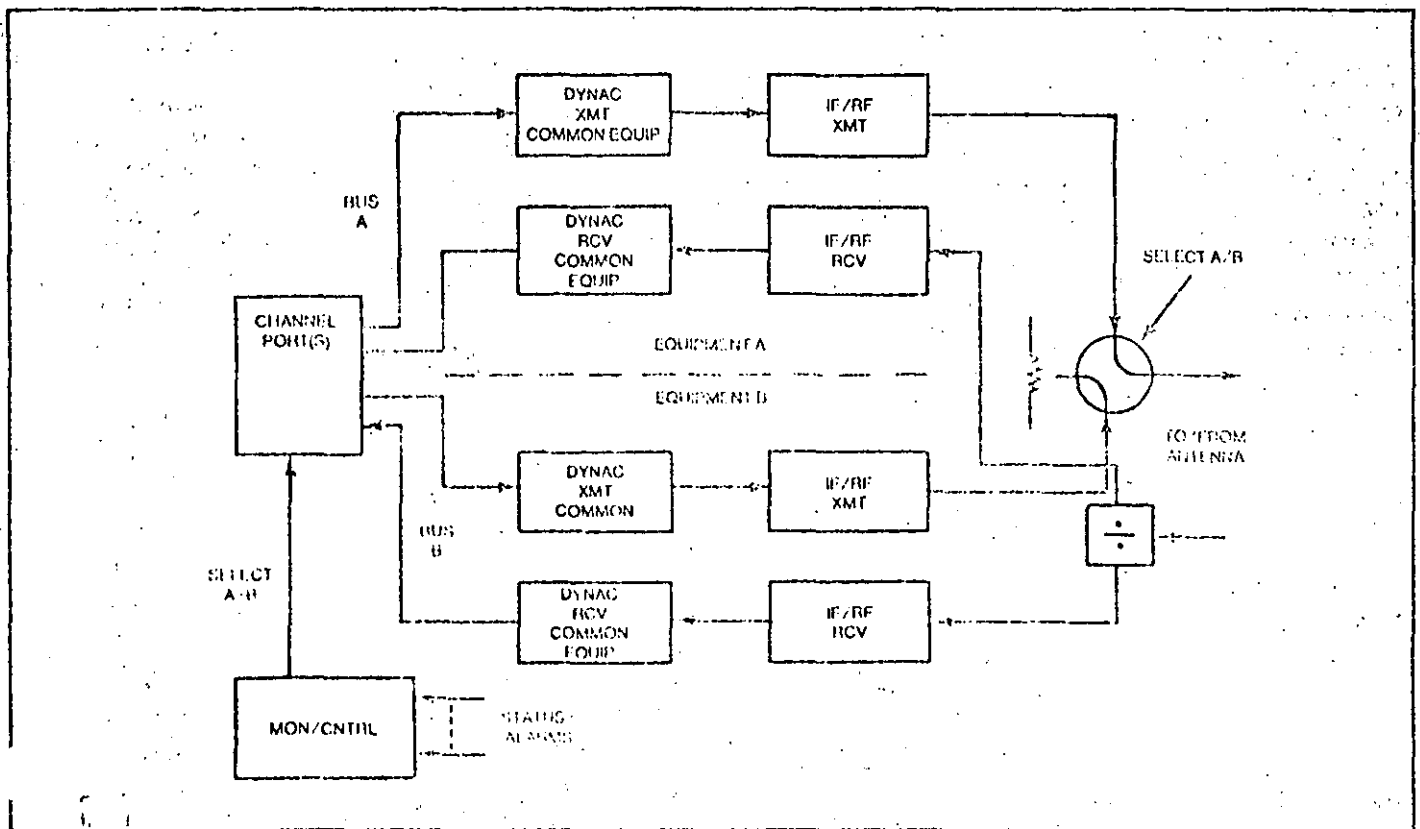


FIGURE 7
Redundancy Scheme

(externally), and then forwarded.

For applications requiring VF interfaces, the DNYAC equipment can be configured with Continuously-Variable-Slope Delta (CVSD) voice codecs, which convert the analog voice input into a 32 kbps continuous data stream. The voice interface is balanced 600-ohm. The CVSD codec is integrated with a fixed rate 32 kbps data port on one printed circuit module, which is compatible with the data port module slots provided in the equipment tray. Thus, voice and data interfaces can be mixed.

To handle telephony signaling, the DYNAC equipment provides an E&M interface, which is used to detect hook status. For dynamic assignment, the E&M is used as a request message, which is forwarded to the central site processor via the overhead signaling channel.

When the VF circuit is established, multiple-frequency (MF) tone signaling (if required) may be sent in band, or single frequency (SF) or E&M signaling is converted to MF

in STAR networks, all VF circuits are connected between the central site and any remote. However, in MESH applications, remote-to-remote connectivity is required. Signaling must first pass in-band (i.e. MF) to the reference site, so that the called earth station can be identified. Once the signaling is received, the network plan is reconfigured, allowing a second VF channel to be established between the reference site and the called earth station. Next, the signaling is forwarded from the reference earth station to the called remote site, upon receipt of which the reference site VF connections are disabled and the remote-to-remote VF is established. This is shown in Figure 8.

Timing and end-to-end delays are a consideration in planning this type of network, and interfaces (switches, etc.) frame rates and the network management system must be thoroughly planned. The dynamic assignment of the VF channels, however, allows for a higher space segment utilization versus fixed assigned channels.

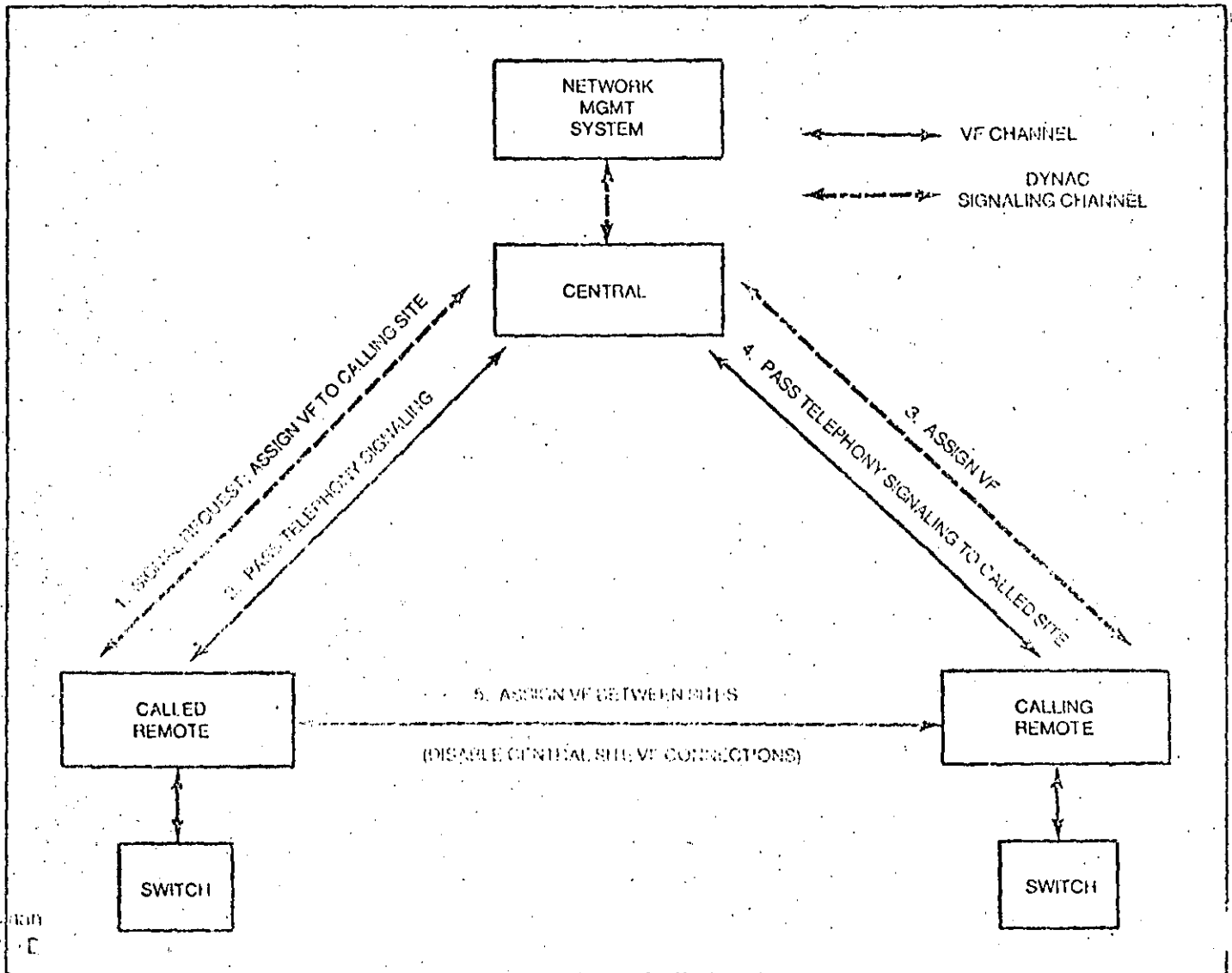


FIGURE 8

Terminal Specifications

292 319

IF/RF Subsystem

Antenna Diameter: Sizes range from 4.6 to 11.0 meters depending on the network configuration and G/T requirements. Table 4 lists some typical antenna characteristics.

PARAMETER	VALUE				
	4.6	5.0	7.0	10.0	11.0
DIAMETER (METERS)					
TYPE	CASSEGRAIN	CASSEGRAIN	CASSEGRAIN	CASSEGRAIN	CASSEGRAIN
OPERATING FREQUENCY (GHZ)	4 6	4 6	4 6	4 6	4 6
TYPICAL GAIN (dBi)	43.5 46.3	44.5 47.3	47.5 50.5	50.85 53.5	52.0 54.5
MOUNT TYPE	quasi-polar	el-over-az	el-over-az	el-over-az	el-over-az
POINTING ACCURACY (°) IN 30 mph WINDS GUSTING TO 45	0.04	0.03	0.04	0.041	0.041
OPERATING TEMPERATURE (°C)	-20 to +55	-20 TO +60	-20 TO +55	-20 TO +55	-20 TO +55
REC. NOISE TEMP. @ 20° EL.	26°K	23°K	26°K	26°K	23°K

Low Noise Amplifier: Available noise temperatures range from 35°K to 120°K depending on the network configuration and G/T requirements. Table 5 lists some typical LNA characteristics.

PARAMETER	Noise Temperature (°K)				
	35	45	70	90	120
Type	parametric		GaAs FET		
operating frequency	3.7 - 4.2 GHz		3.7 - 4.2 GHz		
min. gain	50 dB		50 dB		
max. gain flatness	±0.5 dB		±0.5 dB		
Intermodulation (3rd order)	60 dB rejection for two carriers at input levels of -72 dBm		50 dB below each of two carriers at input levels up to -55 dBm		
overdrive	0 dBm input with no permanent performance degradation		-10 dBm input with no permanent performance degradation		
input connection	CPR-229/G waveguide		CPR-229/G waveguide		
output connection	Type N female		Type N female		

High Power Amplifier: Saturated output powers range from 5 Watts to 400 Watts depending on the network configuration. Table 6 lists some typical HPA characteristics.

PARAMETER	Saturated Output Power (Watts)				
	5	20	75	125	400
Type	GaAs FET		TWTA		
operating frequency	5.925-6.425 GHz		5.925-6.425 GHz		
min. gain	50 dB		50 dB		
gain flatness	±0.4 dB/40 MHz		±1.0 db across 500 MHz		
noise figure	12 dB max		35 dB max		

Subsystem Examples: Typical antenna/LNA/HPA combinations are shown in Table 7.

TABLE 7
Typical Antenna/LNA/HPA Combinations

modem bit rate (Kbps)	network configuration			antenna diameter (M)					HPA sat. output power (watts)				
	Star		mesh	4.6	5	7	10	11	5	20	75	125	400
	central	remote											
268.8		x		x					x				
	x							x	x	x (2cxrs)	x (8cxrs)	x (16cxrs)	x (32cxrs)
268.8			x		x					x			
1.6128		x			x						x		
	x						x				x	x (3cxrs)	x (6cxrs)
1.6128			x		x							x	
1.6128			x				x				x		

NOTE: (1) LNA noise temperature is 120°K for above examples

Frequency Converters: Up and down converter characteristics are shown in Table 8.

TABLE 8
Frequency Converter Characteristics

PARAMETER	up converter	down converter	PARAMETER	up converter	down converter
<u>General Characteristics</u>			<u>Output Characteristics</u>		
type	dual conversion stripline	dual conversion stripline	output level	0 dBm for single carrier input level of -20 dBm	-10 dBm for desired single carrier input of -55 dBm
tuneability	mechanical via crystal change	mechanical via crystal change	1 dB compression point	+10 dBm	0 dBm
frequency sense	no spectral inversion	no spectral conversion	impedance	50 ohms, unbal.	50 ohms, unbal.
<u>Input Characteristics</u>			<u>Transfer Characteristics</u>		
operating frequency	52-88 MHz	3.7-4.2 MHz	center 36MHz BW	center 36MHz BW	center 36MHz BW
translated bandwidth	40 MHz	40 MHz	gain stability (constant temp.)	±0.25dB	±0.25dB
input level	-20 dBm nominal	up to -30 dBm composite	gain slope	±0.1 dB/MHZ	±0.1 dB/MHZ
impedance	50 ohms, unbal.	50 ohms, unbal.	intermodulation (3rd order)	60dBc with two equal RF carriers at an output level of -10dBm	60dBc with two equal IF carriers at an output level of -10dBm
local oscillators					
C-band	4762.5-5222.5MHZ	4762.5-5222.5MHZ			
L-band	1112.5MHZ	1112.5MHZ			

Baseband Interfaces

321 294

Data: RS-232C or V.35
Format: Serial Synchronous
Anal Port Rates: Refer to Table 1
Voice: 4 wire, 600 ohm
Voice Encoding: 32 kbps CVSD
Telephony Signaling: E&M, SF or MF interfaces available

Modem

Modulation: Coherent QPSK, burst or continuous
Operating Bit Rates: Refer to Table 2
Ambiguity Resolution: Unique Word Detection
Forward Error Correction: Rate 1/2 (Selectable)
Rate 7/8 Hard Decision (Optional)
Rate 3/4 Soft Decision (Optional)
AFC: Swept Acquisition, ± 40 kHz
Burst-to-burst + 1 kHz
AGC: ± 10 dB (Continuous)
 ± 2 dB (Burst)
Transmit IF Frequency: .. Selectable from 52 to 88 MHz
(CSO Option Available)
L.O. Stability: Aging $< 1 \times 10^{-7}$ /week
BER Threshold 10^{-4} @ Eb/No = 10.4 dB (uncoded)

Network Control

Time Length: Selectable from 10 ms to 250 ms
Signaling Channels: 512 bits (from NMS)
88 bits (to NMS)
Orderwire Channels: ... May be included in OH signaling
Network Configuration: Automatic, in real time, via
network controller signaling. Typical
reconfiguration times are 2 to 5 seconds.

General Specifications, DYNAC Controller

Fault Indication: Local visual indicators and Form C
summary alarms; automatic status
reporting to central terminal.
Redundancy: 1:1, 1:N configurations available
Power Requirements: 115 VAC, +10%,
60 Hz @ 10 amps
Physical Dimensions: 8.75" (222.3 mm) high,
19" (482.6 mm) wide, 28" (711.2 mm) deep
Weight: 12 kg (approx.)
Mounting: EIA standard
Environment: Operating 10°C to 40°C
Storage -25°C to 85°C

CVSD Codec (Option)

Clock Rate: 32 kbps
Input/Output Impedance 600 Ω balanced $\pm 10\%$
Frequency Response: (at -10 dBm0)
300 - 2500 Hz ± 1 dB
300 - 3000 Hz ± 1 dB, -2 dB
300 - 3400 Hz ± 1 dB, -4 dB

Delay Distortion

600 - 2500 Hz $< 200 \mu\text{sec}$
300 - 3000 Hz $< 500 \mu\text{sec}$
300 - 3400 Hz $< 1000 \mu\text{sec}$

Signal to Quantization Noise

(800 Hz, C-message weighting)

Input: +3 to -20 dBm0 32 dB
-20 to -30 dBm0 30 dB
-30 to -39 dBm0 22 dB

Gain Tracking

(deviation from gain at -20 dBm0)

Input: 800 Hz +3 to 0 dBm0 ± 1.5 dB
0 to -30 dBm0 ± 1.0 dB
-30 to -40 dBm0 ± 1.5 dB

Idle Noise

(C-message weighting) < 65 dBm0

Data Signal Transparency

(2400 bps, bit error rate): $< 10^{-6}$

Support Services

DCC's technical staff is prepared to assist communication managers in the initial definition and planning for a specific network configuration. We are also available to coordinate site surveys and FCC licensing. Installation and maintenance can also be provided.

For further information, contact our satellite communications marketing department.

Preliminary Specification (Subject to Change)

295

322

TERMINAL DST - 1000, TDMA.

295

TELESYSTEMS

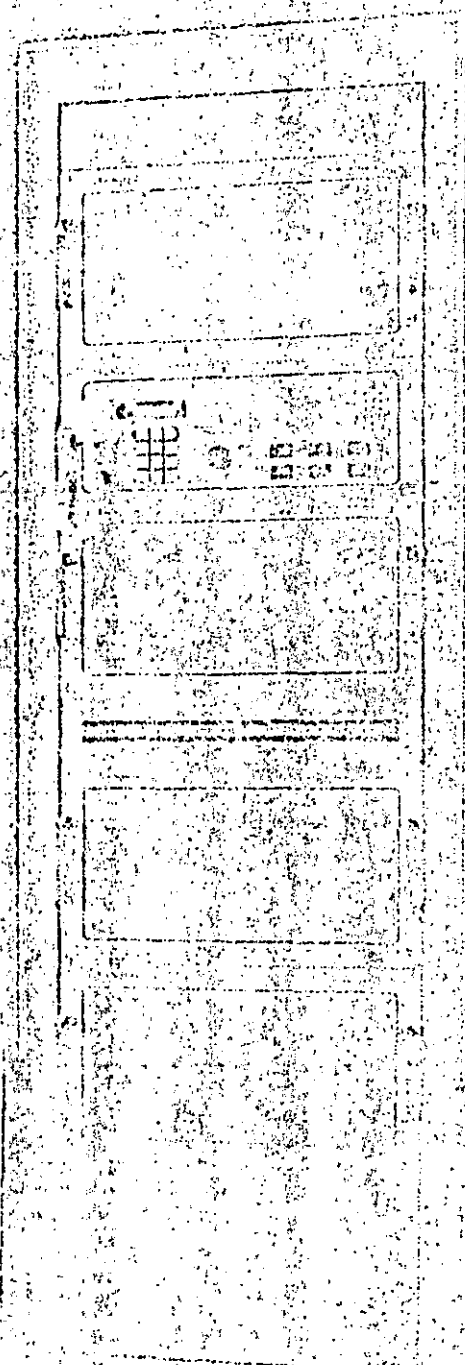
(COMSAT GENERAL)

TELEPHONE SYSTEMS

TELEPHONE SYSTEMS

Advanced TDM/A Today?

TELEPHONE SYSTEMS
TeleSystems



TELEPHONE SYSTEMS

Communications Services

- VOICE: 64 Kb/s PCM embedded in T1 stream with or without E&M, DTMF signaling.
- DATA: 64 Kb/s and N x 64 Kb/s, up to 1.544 Mb/s, embedded in T1 stream.
- VIDEO: encoded into 1.544 Mb/s T1 stream, with or without signaling
- CCITT: Voice, Data & Video Services at 2.048 Mb/s CEPT-32 Standards.
- OTHER: provision can be made to interface with most conventional digital rates and disciplines.

features which lend themselves to evolutionary implementation -- as requirements change, the system can be altered to accommodate those needs without making existing elements obsolete. Similarly, plans for future growth and expansion of the network do not significantly impact initial costs -- there is no need to purchase extra capability initially in order to accommodate anticipated requirements which may or may not materialize as projected.

General Description

The DST-1000 is a medium-rate design for use in private network and common carrier applications requiring burst bit rates of 15 to 60 Mb/s, with capacity for up to 100 stations in the network. Employing the Motorola 68000 family of microprocessors for network management and terminal control, extensive flexibility is achieved in the restructuring of bursts to accommodate changing traffic patterns and user requirements.

Highly effective utilization of space segment capacity is realized by virtue of the fact that burst positions, lengths, and content can readily be adjusted from a central TDMA console. Microprocessor control also achieves considerable reduction in logic components required for the acquisition, synchronization, and traffic management functions, as well as allowing lower rate operation which reduces transponder leasing costs until such time as traffic loads necessitate full transponder operation.

Designed for a wide range of applications, the DST-1000 system offers numerous

Designed for direct interface with T1 PCM encoded voice channels, any conventional interface operating at a 1.544 Mb/s rate can be accommodated. Video conferencing is a

standard feature, as is split T1 operation, permitting individual 64 Kb/s channel streams, or multiples thereof, to be routed individually by source and destination. T1 interfaces are synchronous to the TDMA clock, providing slip-free operation through the system. Similarly, CEPT standards of 2.048 Mb/s are equally acceptable by substituting a different family of Terrestrial Interface Modules (TIM's).

A demand assignment (DAMA) feature, which employs a combination of centralized frame management and distributed call processing, is available either as a part of the initial configuration or as an add-on capability. With this feature, the Network Control Center (NCC) at the Reference Terminal assigns bursts to specific stations within the network, and the individual stations (Local Terminals) access and utilize these time slots to transmit traffic channels on a call-by-call basis, eliminating the need for full-time allocation of slots to service traffic peaks or intermittent demands. This also reduces equipment requirements associated with network synchronization and frame management by requiring a maximum of two stations to be so-equipped, at the same time eliminating much of the frame

Frame Architecture

Dual Reference Bursts are incorporated in the frame architecture, as shown in Figure 1, to ensure utmost reliability in network management. The Reference Bursts maintain frame synchronization via the Transmission Instant Channel, adding and deleting frame space and sending self-test instructions to the individual stations via the Frame Management/Command Channel.

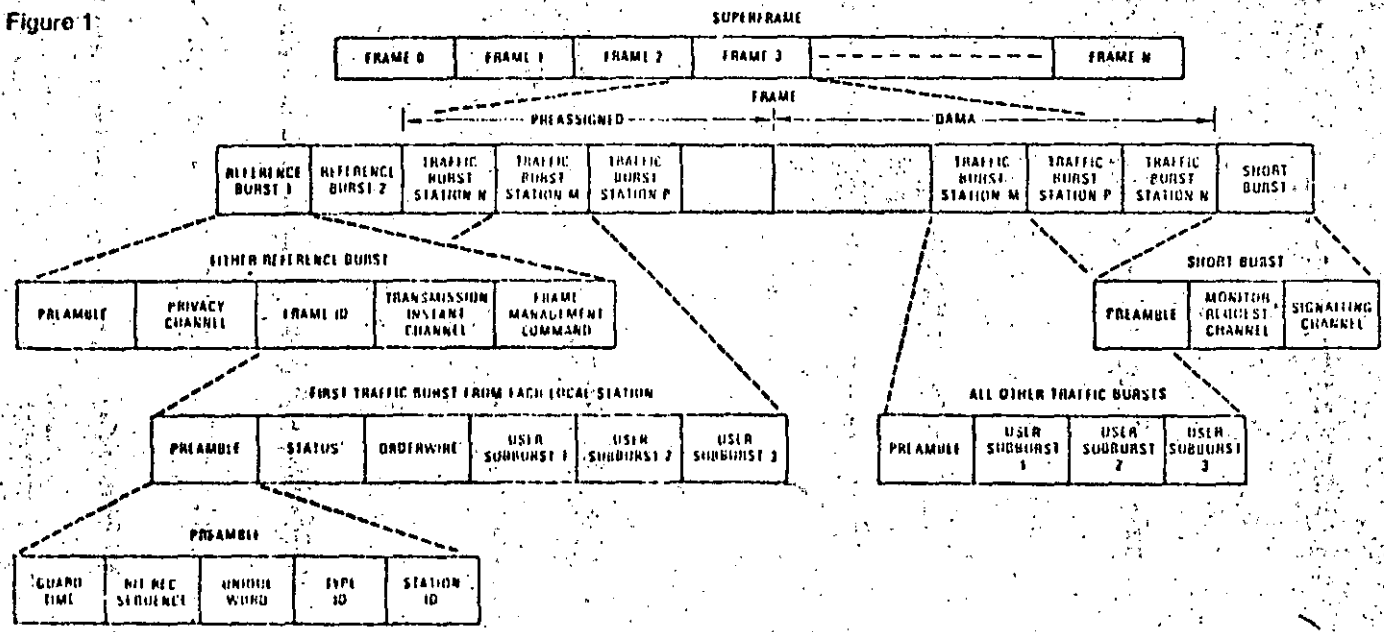
The Privacy Channel of each Reference Burst carries an encrypted scrambler starting key to the Local Terminals; 2ⁿ possible combinations make compromise of network traffic highly improbable.

The future addition of the DAMA feature is accomplished without alteration of the frame architecture by dividing each frame into preassigned and demand assigned segments -- the dynamic nature of the frame architecture allows utilization of those slots for preassigned traffic until such time as the DAMA feature is desired.

Status monitoring and request data are carried between the Local Terminals and the Network Control Centers at the Reference Terminals via a Short Burst included in each frame. This burst also carries call-by-call signaling information when the DAMA option is selected.

Traffic Bursts in the preassigned mode have essentially the same composition as Time Slots in the demand assigned mode. However, with DAMA, the Orderwire Channel is eliminated, this function using demand assigned sub-bursts as required.

Figure 1



DST-1000 TDMA Frame Structure

overhead associated with centralized call control.

Any amount of redundancy can be incorporated. The system can be supplied in a non-redundant configuration where low cost is a predominant consideration and availability criteria can tolerate occasional short outages. Where availability is a prime factor, full redundancy with automatic switchover is offered, with 1:1 redundancy of all common equipment and 1:N redundancy of individual channel equipment.

Conventionally, N=3; however, other ratios can be provided as desired. Similarly, the system can be furnished with a single, non-redundant Reference Station, with two fully redundant Reference Stations, or with any desired mix.

Terminal Configuration

A typical Local Terminal consists of Burst Modems, Frame Management Processors, and Terrestrial Interface Units arranged in a redundant configuration to provide automatic back-up in the event of failure of an on-line unit. In a DAMA application, Terrestrial Signaling Units are employed for processing of the individual calls. A Reference Terminal contains this Local Terminal complement

plus; Frame Supervisory/Network Control Processors, and a Rubidium Clock for network timing. Figure 2 illustrates the Reference Terminal configuration, with the Local Terminal component outlined by a heavy dashed line. The Network Control Center is also a part of the Reference Terminal, and includes interface provision for the Network Monitor and Control System and Centralized Automatic Message Accounting, where required. In a fully redundant network, two such Reference Terminals are employed.

Terminal expansion is greatly facilitated by the bus structure used in interfacing the common equipment with the individual Terrestrial Interface Modules (TIM's). With this arrangement, a variety of terrestrial interfaces can be accommodated without impacting the basic hardware and software structure. Expansion is accomplished by adding TIM's as required. The TIM bus consists of data, address and control lines, with separate buses for transmit and receive paths. During burst transmission, the common equipment presents address and control signals on the transmit TIM bus. Each address identifies a specific TIM and a data block to be read from that TIM, allowing

considerable flexibility in multiplexing TIM data during burst construction. The burst format control network is part of the common equipment. In the receive direction, the opposite functions are performed.

The Modem uses QPSK modulation, employing codeword correlation for resolution of phase ambiguity while avoiding differential encoding loss. Square root Nyquist filters have been selected for the pulse shaping elements, using extensive computer simulation for optimization of BER performance and spectral control.

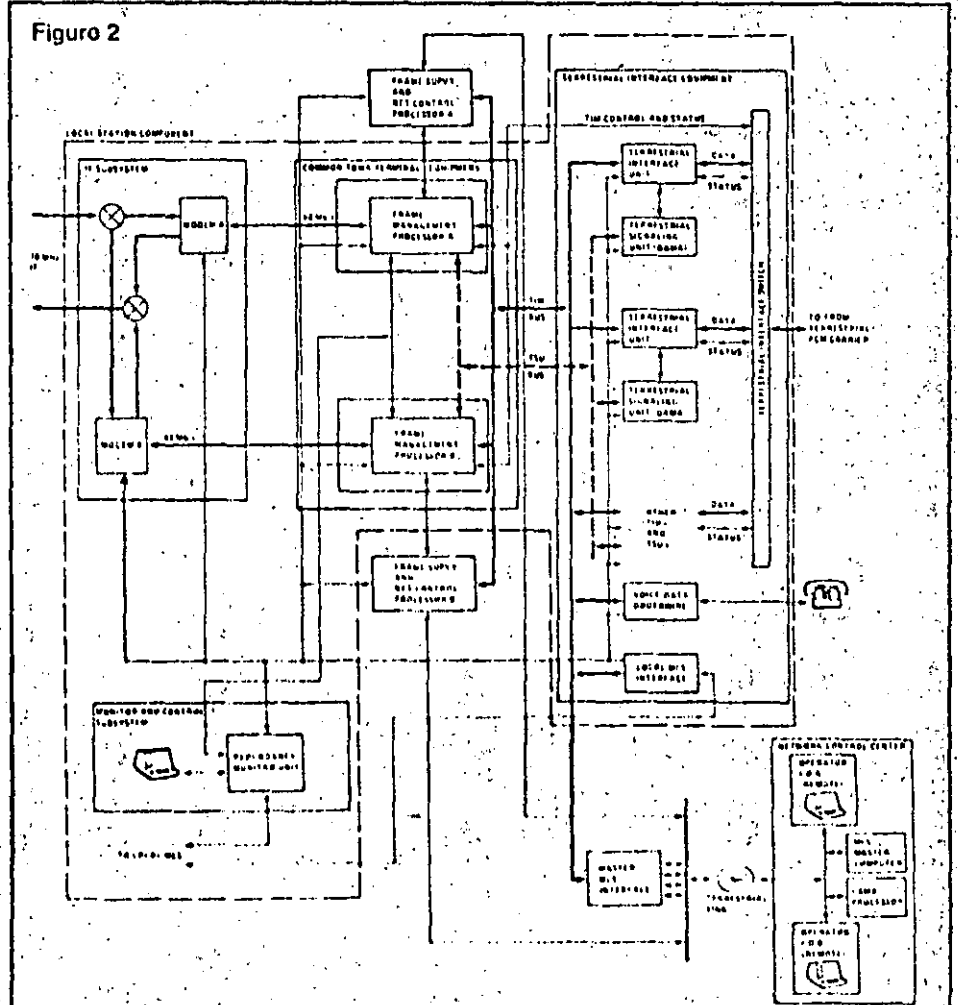
Forward error correction can be employed on any voice, video, data or signaling channel, as required, independent of its use on other channels. A Rate 4/5 Hamming code is utilized, and FEC can be used in DAMA or preassigned operation.

A pseudo random scrambling sequence is introduced to modify all data following the Unique Word, prior to QPSK modulation, dispersing power in the transmitted spectrum per CCIR requirements and permitting clock recovery when long sequences of zeroes are sent. The scrambler starting key is encrypted, using the DES Standard, thus providing a high degree of communications privacy.

Network Maintenance/Operation

Complete monitoring of all local station status by NCC via monitor/request channel.

- remote commands by NCC to execute on-line self-test routines at each local station
- loopback testing of interfaces upon command of remote or local operators
- local station monitoring and fault diagnosis performed by redundancy monitor unit
- local or reference station status available for call-up by operator
- faults automatically detected to board level during on-line operation
- detailed fault testing can be performed with the aid of built-in self-test routines
- voice orderwire facilities
- data orderwire facilities can be used by monitor & control system.



DST-1000 Reference Terminal Block Diagram

- [21] R. T. Chien, "Cyclic decoding procedure for the Bose-Chaudhuri-Hocquenghem codes," *IEEE Trans. Inform. Theory*, vol. IT-10, Oct. 1964, pp. 357-363.
- [22] G. D. Forney, "On decoding BCH codes," *IEEE Trans. Inform. Theory*, vol. IT-11, Oct. 1965, pp. 549-557.
- [23] J. L. Massey, "Shift-register synthesis and BCH decoding," *IEEE Trans. Inform. Theory*, vol. IT-15, Jan. 1969, pp. 122-127.
- [24] ———, *Threshold Decoding*. Cambridge, Mass.: M.I.T. Press, 1963.
- [25] H. F. Mattson and G. Solomon, "A new treatment of Bose-Chaudhuri Codes," *J. Soc. Indust. Appl. Math.*, vol. 9, Dec. 1961, pp. 651-669.
- [26] J. S. Reed, "A class of multiple-error-correcting codes and the decoding scheme," *IRE Trans. Inform. Theory*, vol. IT-4, Sept. 1954, pp. 38-49.
- [27] J. S. Reed and G. Solomon, "Polynomial codes over certain finite fields," *J. Soc. Indust. Appl. Math.*, vol. 8, 1960, pp. 300-304.
- [28] L. D. Rudolph, "Geometric configuration and majority logic decodable codes," M.E.E. thesis, Univ. Oklahoma, Norman, 1964.
- [29] ———, "A class of majority logic decodable codes," *IEEE Trans. Inform. Theory (Corresp.)*, vol. IT-13, Apr. 1967, pp. 305-307.
- [30] ———, "Threshold decoding of cyclic codes," *IEEE Trans. Inform. Theory*, vol. IT-15, May 1969, pp. 414-418.
- [31] J. J. Stone, "Multiple burst error correction," *Inform. Contr.*, vol. 4, Mar. 1961, pp. 324-331.
- [32] S. Y. Tong, "Burst trapping techniques for a compound channel," Bell Telephone Lab., Tech. Memo., 1968.
- [33] K. K. M. Tseng, "On iterative decoding of BCH codes and

decoding beyond the BCH bound." Univ. Illinois, Urbana, CSL Rep. R-104, 1969.

- [34] E. J. Weldon, Jr., "Difference-set cyclic codes," *Bell Syst. Tech. J.*, vol. 45, Sept. 1966, pp. 1045-1055.

299



Robert T. Chien (S'56-M'58) was born in Kiangsu, China, on November 20, 1931. He received the A.M. degree in mathematics and the Ph.D. degree in electrical engineering from the University of Illinois, Urbana, in 1957 and 1958, respectively.

From 1958 to 1965 he was associated with the IBM Thomas J. Watson Research Center, Yorktown Heights, N. Y., where he was responsible for a research group in coding theory and memory addressing. From 1961

to 1963 he was Adjunct Associate Professor at Columbia University, New York, N. Y. In 1965 he joined the University of Illinois where he is currently Professor of Electrical Engineering and Associate Director for Systems at the Coordinated Science Laboratory. He has published in the areas of graph theory, coding theory, artificial intelligence, and information retrieval systems. He is the coauthor of a book, *Topological Analysis and Synthesis of Communication Networks* (New York: Columbia University Press, 1962). He is also a consultant to IBM in error control and coding, digital communication, information retrieval, and memory indexing.

Dr. Chien is a member of Tau Beta Pi and Sigma Xi.

Convolutional Codes and Their Performance in Communication Systems

ANDREW J. VITERBI, SENIOR MEMBER, IEEE

Abstract—This tutorial paper begins with an elementary presentation of the fundamental properties and structure of convolutional codes and proceeds with the development of the maximum likelihood decoder. The powerful tool of generating function analysis is demonstrated to yield for arbitrary codes both the distance properties and upper bounds on the bit error probability for communication over any memoryless channel. Previous results on code ensemble average error probabilities are also derived and extended by these techniques. Finally, practical considerations concerning finite decoding memory, metric representation, and synchronization are discussed.

I. INTRODUCTION

ALTHOUGH convolutional codes, first introduced by Elias [1], have been applied over the past decade to increase the efficiency of numerous communication systems, where they invariably outper-

form block codes of the same order of complexity, there remains to date a lack of acceptance of convolutional coding and decoding techniques on the part of many communication technologists. In most cases, this is due to an incomplete understanding of convolutional codes, whose cause can be traced primarily to the sizable literature in this field, composed largely of papers which emphasize details of the decoding algorithms rather than the more fundamental unifying concepts, and which, until recently, have been divided into two nearly disjoint subsets: This malady is shared by the block-coding literature, wherein the algebraic decoders and probabilistic decoders have been at odds for a considerably longer period.

The convolutional code dichotomy owes its origins to the development of sequential (probabilistic) decoding by Wozencraft [2] and of threshold (feedback, algebraic) decoding by Massey [3]. Until recently the two disciplines flourished almost independently, each with its own literature, applications, and enthusiasts. The Fano sequential decoding algorithm [4] was soon found to

Paper approved by the Communication Theory Committee of the IEEE Communication Technology Group for publication without oral presentation. Manuscript received January 7, 1971; revised June 11, 1971.

The author is with the School of Engineering and Applied Science, University of California, Los Angeles, Calif. 90024, and the Linkabit Corporation, San Diego, Calif.

greatly outperform earlier versions of sequential decoders both in theory and practice. Meanwhile the feedback coding advocates were encouraged by the burst-error correcting capabilities of the codes which render them quite useful for channels with memory.

To add to the confusion, yet a third decoding technique emerged with the Viterbi decoding algorithm [9], which was soon thereafter shown to yield maximum likelihood decisions (Forney [12], Omura [17]). Although this approach is probabilistic and emerged primarily from the sequential-decoding oriented discipline, it leads naturally to a more fundamental approach to convolutional code representation and performance analysis. Furthermore, by emphasizing the decoding-invariant properties of convolutional codes, one arrives directly to the maximum likelihood decoding algorithm and from it to the alternate approaches which lead to sequential decoding on the one hand and feedback decoding on the other. This decoding algorithm has recently found numerous applications in communication systems, two of which are covered in this issue (Heller and Jacobs [24], Cohen *et al.* [25]). It is particularly desirable for efficient communication at very high data rates, where very low error rates are not required, or where large decoding delays are intolerable.

Foremost among the recent works which seek to unify these various branches of convolutional coding theory that of Forney [12], [21], [22], *et seq.*, which includes a three-part contribution devoted, respectively, to algebraic structure, maximum likelihood decoding, and sequential decoding. This paper, which began as an attempt to present the author's original paper [9] to a broader audience,¹ is another such effort at consolidating this discipline.

It begins with an elementary presentation of the fundamental properties and structure of convolutional codes and proceeds to a natural development of the maximum likelihood decoder. The relative distances among codewords are then determined by means of the generating function (or transfer function) of the code state diagram. This in turn leads to the evaluation of coded communication system performance on any memoryless channel. Performance is first evaluated for the specific cases of the binary symmetric channel (BSC) and the additive white Gaussian noise (AWGN) channel with biphasic (or quadriphase) modulation, and finally generalized to other memoryless channels. New results are obtained for the evaluation of specific codes (by the generating function technique), rather than the ensemble average of a class of codes, as had been done previously, and for bit error probability, as distinguished from event error probability.

The previous ensemble average results are then extended to bit error probability bounds for the class of

time-varying convolutional codes by means of a generalized generating function approach; explicit results are obtained for the limiting case of a very noisy channel and compared with the corresponding results for block codes. Finally, practical considerations concerning finite memory, metric representation, and synchronization are discussed. Further and more explicit details on these problems and detailed results of performance analysis and simulation are given in the paper by Heller and Jacobs [24].

While sequential decoding is not treated explicitly in this paper, the fundamentals and techniques presented here lead naturally to an elegant tutorial presentation of this subject, particularly if, following Jelinek [18], one begins with the recently proposed stack sequential decoding algorithm proposed independently by Jelinek and Zigangirov [7], which is far simpler to describe and understand than the original sequential algorithms. Such a development, which proceeds from maximum likelihood decoding to sequential decoding, exploiting the similarities in performance and analysis has been undertaken by Forney [22]. Similarly, the potentials and limitations of feedback decoders can be better understood with the background of the fundamental decoding-invariant convolutional code properties previously mentioned, as demonstrated, for example, by the recent work of Morrissey [15].

II. CODE REPRESENTATION

A convolutional encoder is a linear finite-state machine consisting of a K -stage shift register and n linear algebraic function generators. The input data, which is usually, though not necessarily, binary, is shifted along the register b bits at a time. An example with $K = 3$, $n = 2$, $b = 1$ is shown in Fig. 1.

The binary input data and output code sequences are indicated on Fig. 1. The first three input bits, 0, 1, and 1, generate the code outputs 00, 11, and 01, respectively. We shall pursue this example to develop various representations of convolutional codes and their properties. The techniques thus developed will then be shown to generalize directly to any convolutional code.

It is traditional and instructive to exhibit a convolutional code by means of a tree diagram as shown in Fig. 2.

If the first input bit is a zero, the code symbols are those shown on the first upper branch, while if it is a one, the output code symbols are those shown on the first lower branch. Similarly, if the second input bit is a zero, we trace the tree diagram to the next upper branch, while if it is a one, we trace the diagram downward. In this manner all 32 possible outputs for the first five inputs may be traced.

From the diagram it also becomes clear that after the first three branches the structure becomes repetitive. In fact, we readily recognize that beyond the third branch the code symbols on branches emanating from the two nodes labeled a are identical, and similarly for all the

¹This material first appeared in unpublished form as the notes for the Linkabit Corp., "Seminar on convolutional codes," Jan. 1970.

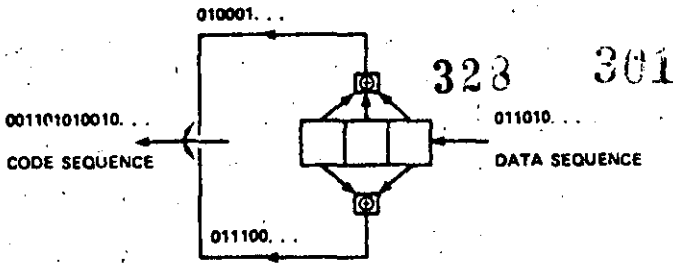


Fig. 1. Convolutional coder for $K = 3, n = 2, b = 1$.

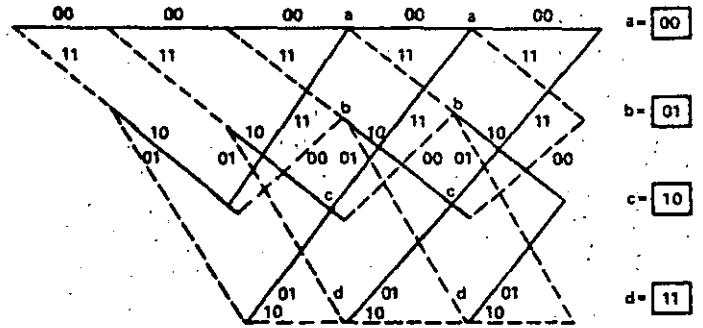


Fig. 3. Trellis-code representation for coder of Fig. 1.

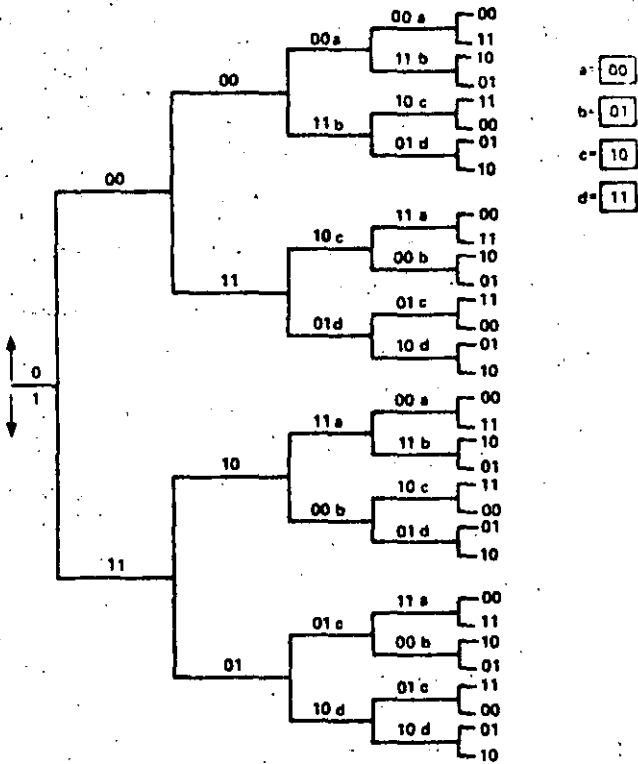


Fig. 2. Tree-code representation for coder of Fig. 1.

identically labeled pairs of nodes. The reason for this is obvious from examination of the encoder. As the fourth input bit enters the coder at the right, the first data bit falls off on the left end and no longer influences the output code symbols. Consequently, the data sequences $100xy \dots$ and $000xy \dots$ generate the same code symbols after the third branch and, as is shown in the tree diagram, both nodes labeled *a* can be joined together.

This leads to redrawing the tree diagram as shown in Fig. 3. This has been called a trellis diagram [12], since a trellis is a tree-like structure with remerging branches. We adopt the convention here that code branches produced by a "zero" input bit are shown as solid lines and code branches produced by a "one" input bit are shown dashed.

The completely repetitive structure of the trellis diagram suggests a further reduction in the representation of the code to the state diagram of Fig. 4. The "states" of the state diagram are labeled according to the nodes of the trellis diagram. However, since the states corres-

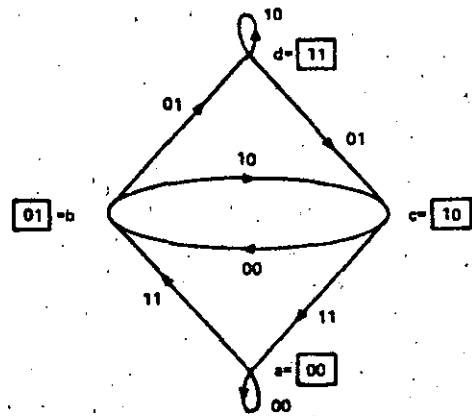


Fig. 4. State-diagram representation for coder of Fig. 1.

pond merely to the last two input bits to the coder we may use these bits to denote the nodes or states of this diagram.

We observe finally that the state diagram can be drawn directly by observing the finite-state machine properties of the encoder and particularly the fact that a four-state directed graph can be used to represent uniquely the input-output relation of the eight-state machine. For the nodes represent the previous two bits while the present bit is indicated by the transition branch; for example, if the encoder (machine) contains 011, this is represented in the diagram by the transition from state $b = 01$ to state $d = 11$ and the corresponding branch indicates the code symbol outputs 01.

III. MINIMUM DISTANCE DECODER FOR BINARY SYMMETRIC CHANNEL

On a BSC, errors which transform a channel code symbol 0 to 1 or 1 to 0 are assumed to occur independently from symbol to symbol with probability p . If all input (message) sequences are equally likely, the decoder which minimizes the overall error probability for any code, block or convolutional, is one which examines the error-corrupted received sequence $y_1 y_2 \dots y_j \dots$ and chooses the data sequence corresponding to the transmitted code sequence $x_1 x_2 \dots x_j \dots$, which is closest to the received sequence in the sense of Hamming distance; that is, the transmitted sequence which differs from the received sequence in the minimum number of symbols.

Referring first to the tree diagram, this implies that we should choose that path in the tree whose code sequence differs in the minimum number of symbols from the received sequence. However, recognizing that the transmitted code branches remerge continually, we may equally limit our choice to the possible paths in the trellis diagram of Fig. 3. Examination of this diagram indicates that it is unnecessary to consider the entire received sequence (which conceivably could be thousands or millions of symbols in length) at one time in deciding upon the most likely (minimum distance) transmitted sequence. In particular, immediately after the third branch we may determine which of the two paths leading to node or state a is more likely to have been sent. For example, if 010001 is received, it is clear that this is at distance 2 from 000000 while it is at distance 3 from 110111 and consequently we may exclude the lower path into node a . For no matter what the subsequent received symbols will be, they will effect the distances only over subsequent branches after these two paths have remerged and consequently in exactly the same way. The same can be said for pairs of paths merging at the other three nodes after the third branch. We shall refer to the minimum distance path of the two paths merging at a given node as the "survivor." Thus it is necessary only to remember which was the minimum distance path from the received sequence (or survivor) at each node, as well as the value of that minimum distance. This is necessary because at the next node level we must compare the two branches merging at each node level, which were survivors at the previous level for different nodes; e.g., the comparison at node a after the fourth branch is among the survivors of comparisons at nodes a and c after the third branch. For example, if the received sequence over the first four branches is 01000111, the survivor at the third node level for node a is 000000 with distance 2 and at node c it is 110101, also with distance 2. In going from the third node level to the fourth the received sequence agrees precisely with the survivor from c but has distance 2 from the survivor from a . Hence the survivor at node a of the fourth level is the data sequence 1100 which produced the code sequence 11010111 which is at (minimum) distance 2 from the received sequence.

In this way we may proceed through the received sequence, and at each step for each state preserve one surviving path and its distance from the received sequence, which is more generally called *metric*. The only difficulty which may arise is the possibility that in a given comparison between merging paths, the distances or metrics are identical. Then we may simply flip a coin as is done for block codewords at equal distances from the received sequence. For even if we preserved both of the equally valid contenders, further received symbols would affect both metrics in exactly the same way and thus not further influence our choice.

This decoding algorithm was first proposed by Viterbi [9] in the more general context of arbitrary memoryless

channels. Another description of the algorithm can be obtained from the state-diagram representation of Fig. 4. Suppose we sought that path around the directed state diagram, arriving at node a after the k th transition, whose code symbols are at a minimum distance from the received sequence. But clearly this minimum distance path to node a at time k can be only one of two candidates: the minimum distance path to node a at time $k - 1$ and the minimum distance path to node c at time $k - 1$. The comparison is performed by adding the new distance accumulated in the k th transition by each of these paths to their minimum distances (metrics) at time $k - 1$.

It appears thus that the state diagram also represents a system diagram for this decoder. With each node or state we associate a storage register which remembers the minimum distance path into the state after each transition as well as a metric register which remembers its (minimum) distance from the received sequence. Furthermore, comparisons are made at each step between the two paths which lead into each node. Thus four comparators must also be provided.

There remains only the question of truncating the algorithm and ultimately deciding on one path rather than four. This is easily done by forcing the last two input bits to the coder to be 00. Then the final state of the code must be $a = 00$ and consequently the ultimate survivor is the survivor at node a , after the insertion into the coder of the two dummy zeros and transmission of the corresponding four code symbols. In terms of the trellis diagram this means that the number of states is reduced from four to two by the insertion of the first zero and to a single state by the insertion of the second. The diagram is thus truncated in the same way as it was begun.

We shall proceed to generalize these code representations and optimal decoding algorithm to general convolutional codes and arbitrary memoryless channels, including the Gaussian channel, in Sections V and VI. However, first we shall exploit the state diagram further to determine the relative distance properties of binary convolutional codes.

IV. DISTANCE PROPERTIES OF CONVOLUTIONAL CODES

We continue to pursue the example of Fig. 1 for the sake of clarity; in the next section we shall easily generalize results. It is well known that convolutional codes are group codes. Thus there is no loss in generality in computing the distance from the all zeros codeword to all the other codewords, for this set of distances is the same as the set of distances from any specific codeword to all the others.

For this purpose we may again use either the trellis diagram or the state diagram. We first of all redraw the trellis diagram in Fig. 5 labeling the branches according to their distance from the all zeros path. Now consider all the paths that merge with the all zeros for the first time at some arbitrary node j .

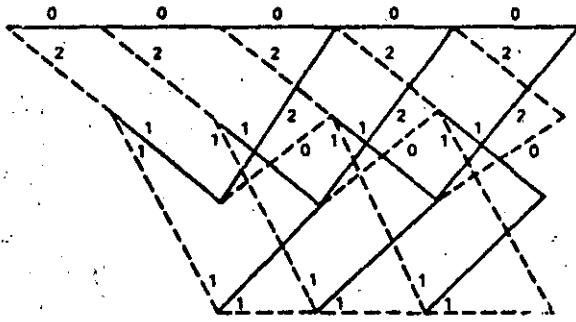


Fig. 5. Trellis diagram labeled with distances from all zeros path.

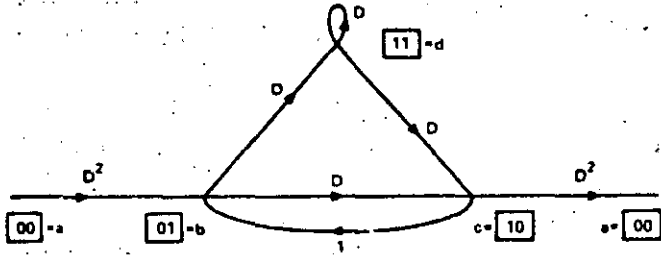


Fig. 6. State diagram labeled according to distance from all zeros path.

It is seen from the diagram that of these paths there will be just one path at distance 5 from the all zeros path and this diverged from it three branches back. Similarly there are two at distance 6 from it, one which diverged 4 branches back and the other which diverged 5 branches back, and so forth. We note also that the input bits for distance 5 path are 00 ... 0100 and thus differ in only one input bit from the all zeros, while the distance 6 paths are 00 ... 01100 and 00 ... 010100 and thus each differs in 2 input bits from the all zeros path. The minimum distance, sometimes called the minimum "free" distance, among all paths is thus seen to be 5. This implies that any pair of channel errors can be corrected, for two errors will cause the received sequence to be at distance 2 from the transmitted (correct) sequence but it will be at least at distance 3 from any other possible code sequence. It appears that with enough patience the distance of all paths from the all zeros (or any arbitrary) path can be so determined from the trellis diagram.

However, by examining instead the state diagram we can readily obtain a closed form expression whose expansion yields directly and effortlessly all the distance information. We begin by labeling the branches of the state diagram of Fig. 4 either D^2 , D , or $D^0 = 1$, where the exponent corresponds to the distance of the particular branch from the corresponding branch of the all zeros path. Also we split open the node $a = 00$, since circulation around this self-loop simply corresponds to branches of the all zeros path whose distance from itself is obviously zero. The result is Fig. 6. Now as is clear from examination of the trellis diagram, every path which arrives at state $a = 00$ at node level j , must have at some previous node level (possibly the first) originated

at this same state $a = 00$. All such paths can be traced on the modified state diagram. Adding branch exponents we see that path $a b c a$ is at distance 5 from the correct path, paths $a b d c a$ and $a b c b c a$ are both at distance 6, and so forth, for the generating functions of the output sequence weights of these paths are D^5 and D^6 , respectively.

Now we may evaluate the generating function of all paths merging with the all zeros at the j th node level simply by evaluating the generating function of all the weights of the output sequences of the finite-state machine.² The result in this case is

$$T(D) = \frac{D^5}{1 - 2D} = D^5 + 2D^6 + 4D^7 + \dots + 2^k D^{k+5} + \dots \quad (1)$$

This verifies our previous observation and in fact shows that among the paths which merge with the all zeros at a given node there are 2^k paths at distance $k + 5$ from the all zeros.

Of course, (1) holds for an infinitely long code sequence; if we are dealing with the j th node level, we must truncate the series at some point. This is most easily done by considering the additional information indicated in the modified state diagram of Fig. 7.

The L terms will be used to determine the length of a given path; since each branch has an L , the exponent of the L factor will be augmented by one every time a branch is passed through. The N term is included only if that branch transition was caused by an input data "one," corresponding to a dotted branch in the trellis diagram. The generating function of this augmented state diagram is then

$$T(D, L, N) = \frac{D^5 L^5 N}{1 - DL(1 + L)N} = D^5 L^5 N + D^6 L^6 (1 + L)N^2 + D^7 L^7 (1 + L)^2 N^3 + \dots + D^{5+k} L^{5+k} (1 + L)^k N^{k+1} + \dots \quad (2)$$

Thus we have verified that of the two distance 6 paths one is of length 4 and the other is of length 5 and both differ in 2 input bits from the all zeros.³ Also, of the distance 7 paths, one is of length 5, two are of length 6, and one is of length 7; all four paths correspond to input sequences with three ones. If we are interested in the j th node level, clearly we should truncate the series such that no terms of power greater than L^j are included.

We have thus fully determined the properties of all paths in the convolutional code. This will be useful later in evaluating error probability performance of codes used over arbitrary memoryless channels.

² Alternatively, this can be regarded as the transfer function of the code if regarded as a signal flow graph.
³ Thus if the all zeros was the correct path and the noise causes us to choose one of the incorrect paths, two bit errors will be made.

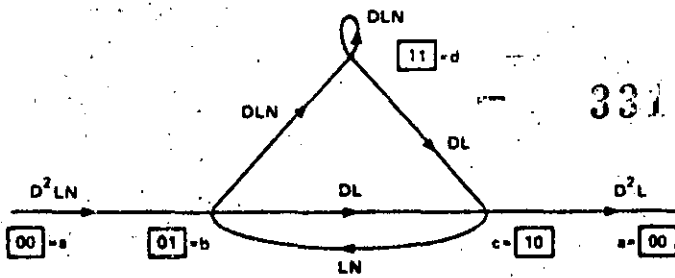


Fig. 7. State diagram labeled according to distance, length, and number of input ones.

V. GENERALIZATION TO ARBITRARY CONVOLUTIONAL CODES

The generalization of these techniques to arbitrary binary-tree ($b = 1$) convolutional codes is immediate. That is, a coder with a K -stage shift register and n mod-2 adders will produce a trellis or state diagram with 2^{K-1} nodes or states and each branch will contain n code symbols. The rate of this code is then

$$R = \frac{1}{n} \text{ bits/code symbol.}$$

The example pursued in the previous sections had rate $R = 1/2$. The primary characteristic of the binary-tree codes is that only two branches exit from and enter each node.

If rates other than $1/n$ are desired we must make $n > 1$, where b is the number of bits shifted into the register at one time. An example for $K = 2, b = 2, n = 3$, and consequently rate $R = 2/3$ is shown in Fig. 8 and its state diagram is shown in Fig. 9. It differs from the binary-tree codes only in that each node is connected to four other nodes, and for general b it will be connected to 2^b nodes. Still all the preceding techniques including the trellis and state-diagram generating function analysis are still applicable. It must be noted, however, that the minimum distance decoder must make comparisons among all the paths entering each node at each level of the trellis and select one survivor out of four (or out of 2^b in general).

VI. GENERALIZATION OF OPTIMAL DECODER TO ARBITRARY MEMORYLESS CHANNELS

Fig. 10 exhibits a communication system employing a convolutional code. The convolutional encoder is precisely the device studied in the preceding sections. The data sequence is generally binary ($a_i = 0$ or 1) and the code sequence is divided into subsequences where \mathbf{x}_j represents the n code symbols generated just after the input bit a_j enters the coder; that is, the symbols of the j th branch. In terms of the example of Fig. 1, $a_j = 1$ and $\mathbf{x}_j = 01$. The channel output or received sequence is similarly denoted. \mathbf{y}_j represents the n symbols received when the n code symbols of \mathbf{x}_j were transmitted. This model includes the BSC wherein the \mathbf{y}_j are binary n vectors each of whose symbols differs from the cor-

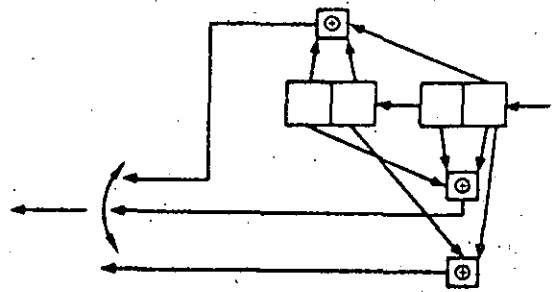


Fig. 8. Coder for $K = 2, b = 2, n = 3$, and $R = 2/3$.

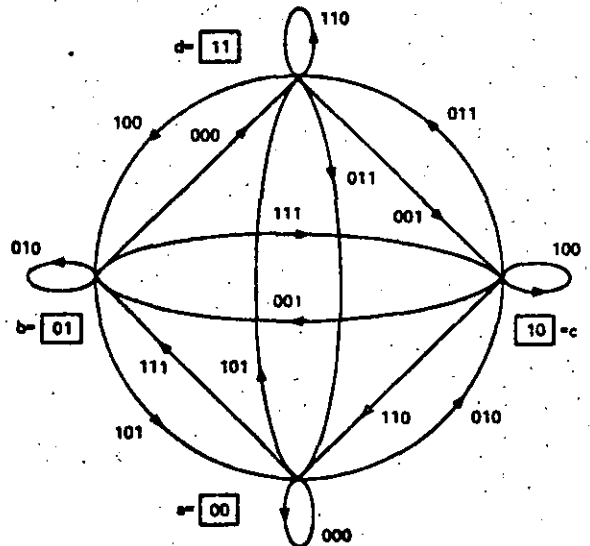


Fig. 9. State diagram for code of Fig. 8.

responding symbol of \mathbf{x}_j with probability p and is identical to it with probability $1 - p$.

For completely general channels it is readily shown [6], [14] that if all input data sequences are equally likely, the decoder which minimizes the error probability is one which compares the conditional probabilities, also called likelihood functions, $P(\mathbf{y} | \mathbf{x}^{(m)})$, where \mathbf{y} is the overall received sequence and $\mathbf{x}^{(m)}$ is one of the possible transmitted sequences, and decides in favor of the maximum. This is called a maximum likelihood decoder. The likelihood functions are given or computed from the specifications of the channel. Generally it is more convenient to compare the quantities $\log P(\mathbf{y} | \mathbf{x}^{(m)})$ called the log-likelihood functions and the result is unaltered since the logarithm is a monotonic function of its (always positive) argument.

To illustrate, let us consider again the BSC. Here each transmitted symbol is altered with probability $p < 1/2$. Now suppose we have received a particular N -dimensional binary sequence \mathbf{y} and are considering a possible transmitted N -dimensional code sequence $\mathbf{x}^{(m)}$ which differs in d_m symbols from \mathbf{y} (that is, the Hamming distance between $\mathbf{x}^{(m)}$ and \mathbf{y} is d_m). Then since the channel is memoryless (i.e., it affects each symbol independently of all the others), the probability

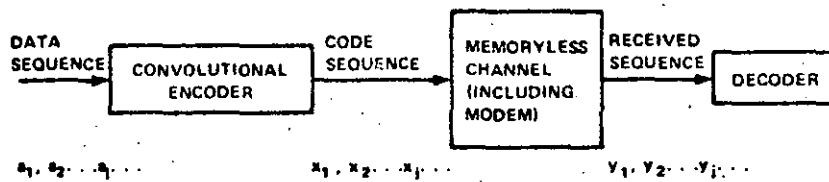


Fig. 10. Communication system employing convolutional codes.

that this $\mathbf{x}^{(m)}$ was transformed to the specific received \mathbf{y} at distance d_m from it is

$$P(\mathbf{y} | \mathbf{x}^{(m)}) = p^{d_m} (1 - p)^{N - d_m}$$

and the log-likelihood function is thus

$$\log P(\mathbf{y} | \mathbf{x}^{(m)}) = -d_m \log(1 - p) + N \log(1 - p)$$

Now if we compute this quantity for each possible transmitted sequence, it is clear that the second term is constant in each case. Furthermore, since we may assume $p < 1/2$ (otherwise the role of 0 and 1 is simply interchanged at the receiver), we may express this as

$$\log P(\mathbf{y} | \mathbf{x}^{(m)}) = -\alpha d_m - \beta \quad (3)$$

where α and β are positive constants and d_m is the (positive) distance. Consequently, it is clear that maximizing the log-likelihood function is equivalent to minimizing the Hamming distance d_m . Thus for the BSC to minimize the error probability we should choose that code sequence at minimum distance from the received sequence, as we have indicated and done in preceding sections.

We now consider a more physical practical channel: the AWGN channel with biphase¹ phase-shift keying (PSK) modulation. The modulator and optimum demodulator (correlator or integrate-and-dump filter) for this channel are shown in Fig. 11.

We use the notation that x_{jk} is the k th code symbol for the j th branch. Each binary symbol (which we take here for convenience to be ± 1) modulates the carrier by $\pm \Pi/2$ radians for T seconds. The transmission rate is, therefore, $1/T$ symbols/second or $b/nT = R/T$ bit/s. The function ϵ_s is the energy transmitted for each symbol. The energy per bit is, therefore $\epsilon_b = \epsilon_s/R$. The white Gaussian noise is a zero-mean random process of one-sided spectral density N_0 W/Hz, which affects each symbol independently. It then follows directly that the channel output symbol y_{jk} is a Gaussian random variable whose mean is $\sqrt{\epsilon_s} x_{jk}$ (i.e., $+\sqrt{\epsilon_s}$ if $x_{jk} = 1$ and $-\sqrt{\epsilon_s}$ if $x_{jk} = -1$) and whose variance is $N_0/2$. Thus the conditional probability density (or likelihood) function of y_{jk} given x_{jk} is

$$p(y_{jk} | x_{jk}) = \frac{\exp[-(y_{jk} - \sqrt{\epsilon_s} x_{jk})^2 / N_0]}{\sqrt{HN_0}} \quad (4)$$

The likelihood function for the j th branch of a particular

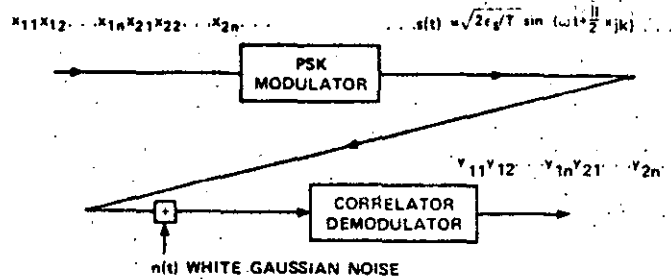


Fig. 11. Modem for additive white Gaussian noise PSK modulated memoryless channel.

code path $\mathbf{x}_j^{(m)}$

$$p(\mathbf{y}_j | \mathbf{x}_j^{(m)}) = \prod_{k=1}^n p(y_{jk} | x_{jk}^{(m)})$$

since each symbol is affected independently by the white Gaussian noise, and thus the log-likelihood function for the j th branch is

$$\begin{aligned} \ln p(\mathbf{y}_j | \mathbf{x}_j^{(m)}) &= \sum_{k=1}^n \ln p(y_{jk} | x_{jk}^{(m)}) \\ &= -\frac{1}{N_0} \sum_{k=1}^n [y_{jk} - \sqrt{\epsilon_s} x_{jk}^{(m)}]^2 - \frac{1}{2} \ln \frac{H}{N_0} \\ &= \frac{2\sqrt{\epsilon_s}}{N_0} \sum_{k=1}^n y_{jk} x_{jk}^{(m)} - \frac{\epsilon_s}{N_0} \sum_{k=1}^n [x_{jk}^{(m)}]^2 \\ &= \frac{1}{N_0} \sum_{k=1}^n y_{jk}^2 - \frac{1}{2} \ln \frac{H}{N_0} \\ &= C \sum_{k=1}^n y_{jk} x_{jk}^{(m)} - D \end{aligned} \quad (5)$$

where C and D are independent of m , and we have used the fact that $[x_{jk}^{(m)}]^2 = 1$. Similarly, the log-likelihood function for any path is the sum of the log-likelihood functions for each of its branches.

We have thus shown that the maximum likelihood decoder for the memoryless AWGN biphase (or quadriphase) modulated channel is one which forms the inner product between the received (real number) sequence and the code sequence (consisting of ± 1) and chooses the path corresponding to the greatest. Thus the metric for this channel is the inner product (5) as contrasted with the distance⁶ metric used for the BSC.

¹ The results are the same for quadriphase PSK with coherent reception. The analysis proceeds in the same way, if we treat quadriphase PSK as two parallel independent biphase PSK channels.

⁶ We have used the natural logarithm here, but obviously a change of base results merely in a scale factor.

⁷ Actually it is easily shown that maximizing an inner product is equivalent to minimizing the Euclidean distance between the corresponding vectors.

For convolutional codes the structure of the code paths was described in Sections II-V. In Section III the optimum decoder was derived for the BSC. It now becomes clear that if we substitute the inner product metric $\sum y_k x_k^{(m)}$ for the distance metric $\sum d_k^{(m)}$, used for the BSC, all the arguments used in Section III for the latter apply equally to this Gaussian channel. In particular the optimum decoder has a block diagram represented by the code state diagram. At step j the stored metric for each state (which is the maximum of the metrics of all the paths leading to this state at this time) is augmented by the branch metrics for branches emanating from this state. The comparisons are performed among all pairs of (or in general sets of 2^b) branches entering each state and the *maxima* are selected as the new most likely paths. The history (input data) of each new survivor must again be stored and the decoder is now ready for step $j+1$.

Clearly, this argument generalizes to any memoryless channel and we must simply use the appropriate metric $\ln P(\mathbf{y} | \mathbf{x}^{(m)})$, which may always be determined from the statistical description of the channel. This includes, among others, AWGN channels employing other forms of modulation.⁷

In the next section, we apply the analysis of convolutional code distance properties of Section IV to determine the error probabilities of specific codes on more general memoryless channels.

VII. PERFORMANCE OF CONVOLUTIONAL CODES ON MEMORYLESS CHANNELS

In Section IV we analyzed the distance properties of convolutional codes employing a state-diagram generating function technique. We now extend this approach to obtain tight upper bounds on the error probability of such codes. We shall consider the BSC, the AWGN channel and more general memoryless channels, in that order. We shall obtain both the first-event error probability, which is the probability that the correct path is excluded (not a survivor) for the first time at the j th step, and the bit error probability which is the expected ratio of bit errors to total number of bits transmitted.

A. Binary Symmetric Channel

The first-event error probability is readily obtained from the generating function $T(D)$ [(5) for the code of Fig. 1, which we shall again pursue for demonstrative purposes]. We may assume, without loss of generality, since we are dealing with group codes, that the all zeros path was transmitted. Then a first-event error is made at the j th step if this path is excluded by selecting another

path merging with the all zeros at node a at the j th level.

Now suppose that the previous-level survivors were such that the path compared with the all zeros at step j is the path whose data sequence is 00...0100 corresponding to nodes $a \dots a \ a \ b \ c \ a$ (see Fig. 4.). This differs from the correct (all zeros) path in five symbols. Consequently an error will be made in this comparison if the BSC caused three or more errors in these particular five symbols. Hence the probability of an error in this specific comparison is

$$P_5 = \sum_{r=3}^5 \binom{5}{r} p^r (1-p)^{5-r} \quad (6)$$

On the other hand, there is no assurance that this particular distance five path will have previously survived so as to be compared with the correct path at the j th step. If either of the distance 6 paths were compared instead, then four or more errors in the six different symbols will definitely cause an error in the survivor decision, while three errors will cause a tie which, if resolved by coin flipping, will result in an error only half the time. Then the probability if this comparison is made is

$$P_6 = \frac{1}{2} \binom{6}{3} p^3 (1-p)^3 + \sum_{r=4}^6 \binom{6}{r} p^r (1-p)^{6-r} \quad (7)$$

Similarly, if the previously surviving paths were such that a distance d path is compared with the correct path at the j th step, the resulting error probability is

$$P_k = \begin{cases} \sum_{r=(k+1)/2}^k \binom{k}{r} p^r (1-p)^{k-r}, & k \text{ odd} \\ \frac{1}{2} \binom{k}{k/2} p^{k/2} (1-p)^{k/2} \\ \quad + \sum_{r=(k/2+1)}^k \binom{k}{r} p^r (1-p)^{k-r}, & k \text{ even.} \end{cases} \quad (8)$$

Now at step j , since there is no simple way of determining previous survivors, we may overbound the probability of a first-event error by the sum of the error probabilities for all possible paths which merge with the correct path at this point. Note this *union bound* is indeed an upper bound because two or more such paths may both have distance closer to the received sequence than the correct path (even though only one has survived to this point) and thus the events are not disjoint. For the example with generating function (1) it follows that the first-event error probability is bounded by

$$P_E < P_5 + 2P_6 + 4P_7 + \dots + 2^k P_{k+3} + \dots \quad (9)$$

where P_k is given by (8).

In Section VII-C it will be shown that (8) can be upper bounded by (see (39))

$$P_k < 2^k p (1-p)^{k/2} \quad (10)$$

Using this, the first-event error probability bound (9)

⁷ Although more elaborate modulators, such as multiple FSK or multiphase modulators, might be employed, Jacobs [11] has shown that the most effective as well as the simplest system for wide-band space and satellite channels is the binary PSK modulator considered in the example of this section. We note again that the performance of quadruphase modulation is the same as for biphasic modulation when both are coherently demodulated.

⁸ We are ignoring the finite length of the path, but the expression is still valid since it is an upper bound.

can be more loosely bounded by

$$P_E < \sum_{k=1}^{\infty} 2^{k-1} 2^k p(1-p)^{k/2} = 334$$

$$= \frac{[2\sqrt{p(1-p)}]^5}{1 - 4\sqrt{p(1-p)}} = T(D) \Big|_{D=2\sqrt{p(1-p)}} \quad (11)$$

where $T(D)$ is just the generating function of (1)

It follows easily that for a general binary-tree ($b = 1$) convolutional code with generating function

$$T(D) = \sum_{k=1}^{\infty} a_k D^k \quad (12)$$

the first-event error probability is bounded by the generalization of (9).

$$P_E < \sum_{k=1}^{\infty} a_k P_k \quad (13)$$

where P_k is given by (8) and more loosely upper bounded by the generalization of (11)

$$P_E < T(D) \Big|_{D=2\sqrt{b(1-p)}} \quad (14)$$

Whenever a decision error occurs, one or more bits will be incorrectly decoded. Specifically, those bits in which the path selected differs from the correct path will be incorrect. If only one error were ever made in decoding an arbitrary long code path, the number of bits in error in this incorrect path could easily be obtained from the augmented generating function $T(D, N)$ (such as given by (2) with factors in L deleted). For the exponents of the N factors indicate the number of bit errors for the given incorrect path arriving at node a at the j th level.

After the first error has been made, the incorrect paths no longer will be compared with a path which is overall correct, but rather with a path which has diverged from the correct path over some span of branches (see Fig. 12). If the correct path x has been excluded by a decision error at step j in favor of path x' , the decision at step $j + 1$ will be between x' and x'' . Now the (first-event) error probability of (13) or (14) is for a comparison, at any step, between path x and any other path merging with it at that step, including path x'' in this case. However, since the metric⁹ for path x' is greater than the metric for x , for on this basis the correct path was excluded at step j , the probability that path x'' metric exceeds path x' metric at step $j + 1$ is less than the probability that path x'' exceeds the (correct) path x metric at this point. Consequently, the probability of a new incorrect path being selected after a previous error has occurred is upper bounded by the first-event error probability at that step.

Moreover, when a second error follows closely after a first error, it often occurs (as in Fig. 12) that the erroneous bit(s) of path x'' overlap the erroneous bit(s) of path x' . With this in mind, we now show that for a

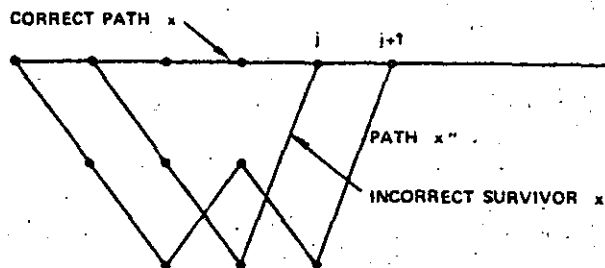


Fig. 12. Example of decoding decision after initial error has occurred.

binary-tree code if we weight each term of the first-event error probability bound at any step by the number of erroneous bits for each possible erroneous path merging with the correct path at that node level, we upper bound the bit error probability. For, a given step decision corresponds to decoder action on one more bit of the transmitted data sequence; the first-event error probability union bound with each term weighted by the corresponding number of bit errors is an upper bound on the expected number of bit errors caused by this action. Summing the expected number of bit errors over L steps, which as was just shown may result in overestimating through double counting, gives an upper bound on the expected number of bit errors in L branches for arbitrary L . But since the upper bound on expected number of bit errors is the same at each step, it follows, upon dividing the sum of L equal terms by L , that this expected number of bit errors per step is just the bit error probability P_B for a binary-tree code ($b = 1$). If $b > 1$, then we must divide this expression by b , the number of bits encoded and decoded per step.

To illustrate the calculation of P_B for a convolutional code, let us consider again the example of Fig. 1. Its transfer function in D and N is obtained from (2), letting $L = 1$, since we are not now interested in the lengths of incorrect paths, to be

$$T(D, N) = \frac{D^5 N}{1 - 2DN}$$

$$= D^5 N + 2D^6 N^2 = \dots + 2^k D^{k+5} N^{k+1} + \dots \quad (15)$$

The exponents of the factors in N in each term determine the number of bit errors for the path(s) corresponding to that term. Since $T(D) = T(D, N) \Big|_{N=1}$ yields the first-event error probability P_E , each of whose terms must be weighted by the exponent of N to obtain P_B , it follows that we should first differentiate $T(D, N)$ at $N = 1$ to obtain

$$\frac{dT(D, N)}{dN} \Big|_{N=1}$$

$$= D^5 + 2 \cdot 2D^6 + 3 \cdot 4D^7 + \dots + (k+1)2^k D^{k+5} + \dots$$

$$= \frac{D^5}{(1 - 2D)^2} \quad (16)$$

⁹ Negative distance from the received sequence for the BSC, but clearly this argument generalizes to any memoryless channel.

Then from this we obtain, as in (9), that for the BSC

$$P_B < P_6 + 2 \cdot 2P_6 + 3 \cdot 4P_7 + \dots + (k+1)2^k P_{k+k} + \dots \quad (17)$$

where P_k is given by (8).

If for P_k we use the upper bound (10) we obtain the weaker but simpler bound

$$\begin{aligned} P_B &< \sum_{k=3}^{\infty} (k-4)2^{k-3} [4p(1-p)]^{k/2} \\ &= \frac{dT(D, N)}{dN} \Big|_{N=1, D=2\sqrt{p(1-p)}} \\ &= \frac{[2\sqrt{p(1-p)}]^3}{[1-4\sqrt{p(1-p)}]^2} \end{aligned} \quad (18)$$

More generally for any binary-tree ($b=1$) code used on the BSC if

$$\frac{dT(D, N)}{dN} \Big|_{N=1} = \sum_{k=d}^{\infty} c_k D^k \quad (19)$$

then corresponding to (17)

$$P_B < \sum_{k=d}^{\infty} c_k P_k \quad (20)$$

and corresponding to (18) we have the weaker bound

$$P_B < \frac{dT(D, N)}{dN} \Big|_{N=1, D=2\sqrt{p(1-p)}} \quad (21)$$

For a nonbinary-tree code ($b \neq 1$), all these expressions must be divided by b .

The results of (14) and (18) will be extended to more general memoryless channels, but first we shall consider one more specific channel of particular interest.

B. AWGN Biphasic-Modulated Channel

As was shown in Section VI the decoder for this channel operates in exactly the same way as for the BSC, except that instead of Hamming distance it uses the metric

$$\sum_{i=1}^n x_{ij} y_{ij}$$

where $x_{ij} = \pm 1$ are the transmitted code symbols, y_{ij} the corresponding received (demodulated) symbols, and j runs over the n symbols of each branch while i runs over all the branches in a particular path. Hence, to analyze its performance we may proceed exactly as in Section VII-A except that the appropriate pairwise-decision errors P_k must be substituted for those of (6) to (8).

As before we assume, without loss of generality, that the correct (transmitted) path \mathbf{x} has $x_{ij} = +1$ for all i and j (corresponding to the all zeros if the input symbols were 0 and 1). Let us consider an incorrect path \mathbf{x}' merging with the correct path at a particular step, which has k negative symbols ($x'_{ij} = -1$) and the remainder positive. Such a path may be incorrectly chosen only if it has a

higher metric than the correct path, i.e.,

$$\sum_{i=1}^k x'_{ij} y_{ij} \geq \sum_{i=1}^k x_{ij} y_{ij}$$

or

$$\sum_{i=1}^k (x'_{ij} - x_{ij}) y_{ij} \geq 0$$

where i runs over all branches in the two paths. But since, as we have assumed, the paths \mathbf{x} and \mathbf{x}' differ in exactly k symbols, wherein $x_{ij} = 1$ and $x'_{ij} = -1$, the pairwise error probability is just

$$\begin{aligned} P_k &= \Pr \left\{ \sum_{i=1}^k \sum_{j=1}^n (x'_{ij} - x_{ij}) y_{ij} \geq 0 \right\} \\ &= \Pr \left\{ \sum_{r=1}^k (x'_r - x_r) y_r \geq 0 \right\} \\ &= \Pr \left\{ -2 \sum_{r=1}^k y_r \geq 0 \right\} \\ &= \Pr \left\{ \sum_{r=1}^k y_r \leq 0 \right\} \end{aligned} \quad (22)$$

where r runs over the k symbols wherein the two paths differ. Now it was shown in Section VI that the y_{ij} are independent Gaussian random variables of variance $N_0/2$ and mean $\sqrt{\epsilon_s} x_{ij}$, where x_{ij} is the actually transmitted code symbol. Since we are assuming that the (correct) transmitted path has $x_{ij} = +1$ for all i and j , it follows that y_{ij} or y_r has mean $\sqrt{\epsilon_s}$ and variance $N_0/2$. Therefore, since the k variables y_r are independent and Gaussian, the sum $Z = \sum_{r=1}^k y_r$ is also Gaussian with mean $k\sqrt{\epsilon_s}$ and variance $kN_0/2$.

Consequently,

$$\begin{aligned} P_k &= \Pr(Z < 0) = \int_{-\infty}^0 \frac{\exp(-Z - k\sqrt{\epsilon_s})^2 / kN_0}{\sqrt{\pi kN_0}} dZ \\ &= \int_{\sqrt{2k\epsilon_s}/N_0}^{\infty} \left[\frac{\exp(-x^2/2)}{\sqrt{2\pi}} \right] dx \triangleq \text{erfc} \sqrt{\frac{2k\epsilon_s}{N_0}} \end{aligned} \quad (23)$$

We recall from Section VI that ϵ_s is the symbol energy, which is related to the bit energy by $\epsilon_s = R\epsilon_b$, where $R = b/n$. The bound on P_B then follows exactly as in Section VII-A and we obtain the same general bound as (13)

$$P_B < \sum_{k=d}^{\infty} a_k P_k \quad (24)$$

where a_k are the coefficients of

$$T(D) = \sum_{k=d}^{\infty} a_k D^k \quad (25)$$

and where d is the minimum distance between any two paths in the code. We may simplify this procedure considerably while loosening the bound only slightly for this channel by observing that for $x \geq 0, y \geq 0$,

$$\text{erfc} \sqrt{x+y} \leq \exp\left(-\frac{y}{x}\right) \text{erfc} \sqrt{x} \quad (26)$$

Consequently, for $k \geq d$, letting $l = k - d$, we have from (23)

$$P_k = \operatorname{erfc} \sqrt{\frac{2k\epsilon_s}{N_0}} = \operatorname{erfc} \sqrt{\frac{2(d+l)\epsilon_s}{N_0}} \\ \leq \exp\left(\frac{-l\epsilon_s}{N_0}\right) \operatorname{erfc} \sqrt{\frac{2d\epsilon_s}{N_0}} \quad (27)$$

whence the bound of (24), using (27), becomes

$$P_E < \sum_{k=d}^{\infty} a_k P_k \leq \operatorname{erfc} \sqrt{\frac{2d\epsilon_s}{N_0}} \sum_{k=d}^{\infty} a_k \exp\left[-\frac{(k-d)\epsilon_s}{N_0}\right]$$

or

$$P_E < \operatorname{erfc} \sqrt{\frac{2d\epsilon_s}{N_0}} \exp\left(\frac{d\epsilon_s}{N_0}\right) T(D) \Big|_{N_0 = \exp(-\epsilon_s/N_0)} \quad (28)$$

The bit error probability can be obtained in exactly the same way. Just as for the BSC [(19) and (20)] we have that for a binary-tree code

$$P_E < \sum_{k=d}^{\infty} c_k P_k \quad (29)$$

where c_k are the coefficients of

$$\frac{dT(D, N)}{dN} \Big|_{N=1} = \sum_{k=d}^{\infty} c_k D^k \quad (30)$$

Thus following the same arguments which led from (24) to (28) we have for a binary-tree code

$$P_E < \operatorname{erfc} \sqrt{\frac{2d\epsilon_s}{N_0}} \exp\left(\frac{d\epsilon_s}{N_0}\right) \frac{dT(D, N)}{dN} \Big|_{N=1, D = \exp(-\epsilon_s/N_0)} \quad (31)$$

For $b > 1$, this expression must be divided by b .

To illustrate the application of this result we consider the code of Fig. 1 with parameters $K = 3$, $R = 1/2$, whose transfer function is given by (15). For this case since $R = 1/2$ and $\epsilon_s = 1/2 \epsilon_b$, we obtain

$$P_E < \frac{\operatorname{erfc} \sqrt{5\epsilon_b/N_0}}{(1 - 2e^{-\epsilon_b/2N_0})} \quad (32)$$

Since the number of states in the state diagram grows exponentially with K , direct calculation of the generating function becomes unmanageable for $K > 4$. On the other hand, a generating function calculation is basically just a matrix inversion (see Appendix I), which can be performed numerically for a given value of D . The derivative at $N = 1$ can be upper bounded by evaluating the first difference $[T(D, 1 + \epsilon) - T(D, 1)]/\epsilon$, for small ϵ . A computer program has been written to evaluate (31) for any constraint length up to $K = 10$ and all rates $R = 1/n$ as well as $R = 2/3$ and $R = 3/4$. Extensive results of these calculations are given in the paper by Heller and Jacobs [24], along with the results of simulations of the corresponding codes and channels. The simulations verify the tightness of the bounds.

In the next section, these bounding techniques will be extended to more general memoryless channels; from which (28) and (31) can be obtained directly, but with-

out the first two factors. Since the product of the first two factors is always less than one, the more general bound is somewhat weaker.

C. General Memoryless Channels

As was indicated in Section VI, for equally likely input data sequences, the minimum error probability decoder chooses the path which maximizes the log-likelihood function (metric)

$$\ln P(\mathbf{y} | \mathbf{x}^{(m)})$$

over all possible paths $\mathbf{x}^{(m)}$. If each symbol is transmitted (or modulates the transmitter) independent of all preceding and succeeding symbols, and the interference corrupts each symbol independently of all the others, then the channel, which includes the modem, is said to be memoryless¹⁰ and the log-likelihood function

$$\ln P(\mathbf{y} | \mathbf{x}^{(m)}) = \sum_i \sum_{j=1}^n \ln P(y_{ij} | x_{ij}^{(m)})$$

where $x_{ij}^{(m)}$ is a code symbol of the m th path, y_{ij} is the corresponding received (demodulated) symbol, j runs over the n symbols of each branch, and i runs over the branches in the given path. This includes the special cases considered in Sections VII-A and -B.

The decoder is the same as for the BSC except for using this more general metric. Decisions are made after each set of new branch metrics have been added to the previously stored metrics. To analyze performance, we must merely evaluate P_k , the pairwise error probability, for an incorrect path which differs in k symbols from the correct path, as was done for the special channels of Sections VII-A and -B. Proceeding as in (22), letting x_{ij} and x'_{ij} denote symbols of the correct and incorrect paths, respectively, we obtain

$$P_k(\mathbf{x}, \mathbf{x}') \\ = \Pr \left[\sum_{r=1}^k \sum_{j=1}^n \ln P(y_{rj} | x'_{rj}) > \sum_{j=1}^n \ln P(y_{rj} | x_{rj}) \right] \\ = \Pr \left\{ \sum_{r=1}^k \ln \frac{P(y_r | x'_r)}{P(y_r | x_r)} > 0 \right\} \\ = \Pr \left\{ \prod_{r=1}^k \frac{P(y_r | x'_r)}{P(y_r | x_r)} > 1 \right\} \quad (33)$$

where r runs over the k code symbols in which the paths differ. This probability can be rewritten as

$$P_k(\mathbf{x}, \mathbf{x}') = \sum_{\mathbf{y} \in Y_k} \prod_{r=1}^k P(y_r | x_r) \quad (34)$$

where Y_k is the set of all vectors $\mathbf{y} = (y_1, y_2, \dots, y_r, \dots, y_k)$ for which

¹⁰ Often more than one code symbol in a given branch is used to modulate the transmitter at one time. In this case, provided the interference still affects succeeding branches independently, the channel can still be treated as memoryless but now the symbol likelihood functions are replaced by branch likelihood functions and (33) is replaced by a single sum over i .

$$\prod_{r=1}^k \frac{P(y_r | x_r')}{P(y_r | x_r)} > 1. \quad (35)$$

337

if this is the case, then

$$P_k(\mathbf{x}, \mathbf{x}') < \sum_{\mathbf{y} \in \mathcal{Y}} \prod_{r=1}^k P(y_r | x_r) \left[\frac{P(y_r | x_r')}{P(y_r | x_r)} \right]^{1/2} < \sum_{\mathbf{y} \in \mathcal{Y}} \prod_{r=1}^k P(y_r | x_r)^{1/2} P(y_r | x_r')^{1/2} \quad (36)$$

where \mathcal{Y} is the entire space of received vectors.¹¹ The

$$\int_{-\infty}^{\infty} p(y_r | x_r)^{1/2} p(y_r | x_r')^{1/2} dy_r = \frac{1}{\sqrt{\pi N_0}} \int_{-\infty}^{\infty} \exp \left\{ -\frac{[(y_r - \sqrt{\epsilon_s} x_r)^2 + (y_r - \sqrt{\epsilon_s} x_r')^2]}{2N_0} \right\} dy_r = \frac{1}{\sqrt{\pi N_0}} \int_{-\infty}^{\infty} \exp \left[-\frac{(y_r^2 + \epsilon_s)}{N_0} \right] dy_r = \exp \left(\frac{-\epsilon_s}{N_0} \right)$$

first inequality is valid because we are multiplying the summand by a quantity greater than unity,¹² and the second because we are merely extending the sum of positive terms over a larger set. Finally we may break up the k -dimensional sum over \mathbf{y} into k one-dimensional summations over y_1, y_2, \dots, y_k , respectively, and this yields

$$P_k(\mathbf{x}, \mathbf{x}') \leq \sum_{y_1} \sum_{y_2} \dots \sum_{y_k} \prod_{r=1}^k P(y_r | x_r)^{1/2} P(y_r | x_r')^{1/2} = \prod_{r=1}^k \sum_{y_r} P(y_r | x_r)^{1/2} P(y_r | x_r')^{1/2} \quad (37)$$

To illustrate the use of this bound we consider the two specific channels treated above. For the BSC, y_r is either equal to x_r , the transmitted symbol, or to \bar{x}_r , its complement. Now y_r depends on x_r through the channel statistics. Thus

$$P(y_r = x_r) = 1 - p \\ P(y_r = \bar{x}_r) = p. \quad (38)$$

For each symbol in the set $r = 1, 2, \dots, k$ by definition $x_r \neq x_r'$. Hence for each term in the sum if $x_r = 0, x_r' = 1$ or vice versa. Hence, whatever x_r and x_r' may be

$$\sum_{y_r=0}^1 P(y_r | x_r)^{1/2} P(y_r | x_r')^{1/2} = 2p^{1/2}(1-p)^{1/2}$$

and the product (37) of k identical factors is

$$P_k = 2^k p^{k/2} (1-p)^{k/2} \quad (39)$$

for all pairs of correct and incorrect paths. This was used in Section VII-A to obtain the bounds (11) and (21).

For the AWGN channel of Section VII-B we showed

¹¹ This would be the set of all 2^k k -dimensional binary vectors for the BSC, and Euclidean k space for the AWGN channel. Note also that the bound of (36) may be improved for asymmetric channels by changing the two exponents of $1/2$ to s and $1-s$, respectively, where $0 < s < 1$.

¹² The square root of a quantity greater than one is also greater than one.

that the likelihood functions (probability densities) were

$$p(y_r | x_r) = \frac{\exp[-(y_r - \sqrt{\epsilon_s} x_r)^2 / N_0]}{\sqrt{\pi N_0}} \quad (40)$$

where $x_r = +1$ or -1 and

$$x_r + x_r' = 0. \quad (41)$$

Since y_r is a real variable, the space of y_r is the real line and the sum in (37) becomes the integral

where we have used (41) and $x_r^2 = x_r'^2 = 1$. The product of these k identical terms is, therefore,

$$P_k < \exp \left(\frac{-k\epsilon_s}{N_0} \right) \quad (42)$$

for all pairs of correct and incorrect paths. Inserting these bounds in the general expressions (24) and (29), and using (25) and (30) yields the bound on first-event error probability and bit error probability.

$$P_E < T(D) |_{D = \exp(-\epsilon_s/N_0)} \quad (43)$$

$$P_B < \frac{dT(D, N)}{dN} \Big|_{N=1, D = \exp(-\epsilon_s/N_0)} \quad (44)$$

which are somewhat (though not exponentially) weaker than (28) and (31).

A characteristic feature of both the BSC and the AWGN channel is that they affect each symbol in the same way independent of its location in the sequence. Any memoryless channel has this property provided it is stationary (statistically time invariant). For a stationary memoryless channel (37) reduces to

$$P_k(\mathbf{x}, \mathbf{x}') < \left[\sum_{y_r} P(y_r | x_r)^{1/2} P(y_r | x_r')^{1/2} \right]^k \triangleq D_0^k \quad (45)$$

where¹³

$$D_0 \triangleq \sum_{y_r} P(y_r | x_r)^{1/2} P(y_r | x_r')^{1/2} < 1. \quad (46)$$

While this bound on P_k is valid for all such channels, clearly it depends on the actual values assumed by the symbols x_r and x_r' of the correct and incorrect path, and these will generally vary according to the pairs of paths \mathbf{x} and \mathbf{x}' in question. However, if the input symbols are binary, x and \bar{x} , whenever $x_r = x$, then $x_r' = \bar{x}$,

¹³ For an asymmetric channel this bound may be improved by changing the two exponents $1/2$ to s and $1-s$, respectively, where $0 < s < 1$.

so that for any input-binary memoryless channel (46) becomes

$$D_0 = \sum_y P(y|x)^{1/2} P(y|\bar{x})^{1/2} \quad (47)$$

and consequently

$$P_E < T(D) |_{D=D_0} \quad (48)$$

$$P_E < \frac{dT(D, N)}{dN} \Big|_{N=1, D=D_0} \quad (49)$$

where D_0 is given by (47). Other examples of channels of this type are FSK modulation over the AWGN (both coherent and noncoherent) and Rayleigh fading channels.

VIII. SYSTEMATIC AND NONSYSTEMATIC CONVOLUTIONAL CODES

The term *systematic* convolutional code refers to a code on each of whose branches one of the code symbols is just the data bit generating that branch. Thus a systematic coder will have its stages connected to only $n - 1$ adders, the n th being replaced by a direct line from the first stage to the commutator. Fig. 13 shows an $R = 1/2$ systematic coder for $K = 3$.

It is well known that for group block codes, any nonsystematic code can be transformed into a systematic code which performs exactly as well. This is not the case for convolutional codes. The reason for this is that, as was shown in Section VII, the performance of a code on any channel depends largely on the relative distances between codewords and particularly on the minimum free distance d , which is the exponent of D in the leading term of the generating function. Eliminating one of the adders results in a reduction of d . For example, the maximum free distance code for $K = 3$ is that of Fig. 13 and this has $d = 4$, while the nonsystematic $K = 3$ code of Fig. 1 has minimum free distance $d = 5$. Table I shows the maximum minimum free distance for systematic and nonsystematic codes for $K = 2$ through 5. For large constraint lengths the results are even more widely separated. In fact, Bucher and Heller [19] have shown that for asymptotically large K , the performance of a systematic code of constraint length K is approximately the same as that of a nonsystematic code of constraint length $K(1 - R)$. Thus for $R = 1/2$ and very large K , systematic codes have the performance of nonsystematic codes of half the constraint length, while requiring exactly the same optimal decoder complexity. For $R = 3/4$, the constraint length is effectively divided by 4.

IX. CATASTROPHIC ERROR PROPAGATION IN CONVOLUTIONAL CODES

Massey and Sain [13] have defined a catastrophic error as the event that a finite number of channel symbol errors causes an infinite number of data bit errors to be decoded. Furthermore, they showed that a necessary and sufficient condition for a convolutional code to produce

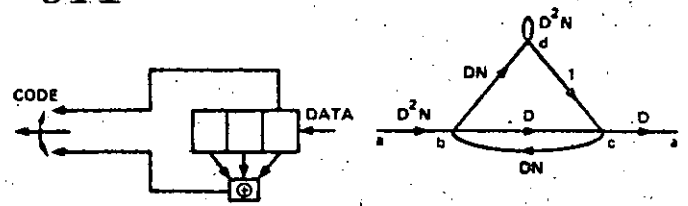


Fig. 13. Systematic convolutional coder for $K = 3$ and $r = 1/2$.

TABLE I
MAXIMUM-MINIMUM FREE DISTANCE

K	Systematic	Nonsystematic*
2	3	3
3	4	5
4	4	6
5	5	7

* We have excluded catastrophic codes (see Section IX); $R = 1/2$.

catastrophic errors is that all of the adders have tap sequences, represented as polynomials, with a common factor.

In terms of the state diagram it is easily seen that catastrophic errors can occur if and only if any closed loop path in the diagram has a zero weight (i.e., the exponent of D for the loop path is zero). To illustrate this, we consider the example of Fig. 14.

Assuming that the all zeros is the correct path, the incorrect path $a b d d \dots d c a$ has exactly 6 ones, no matter how many times we go around the self loop d . Thus for a BSC, for example, four-channel errors may cause us to choose this incorrect path or consequently make an arbitrarily large number of bit errors (equal to two plus the number of times the self loop is traversed). Similarly for the AWGN channel this incorrect path with arbitrarily many corresponding bit errors will be chosen with probability $\text{erfc} \sqrt{6\epsilon_b/N_0}$.

Another necessary and sufficient condition for catastrophic error propagation, recently found by Odenwalder [20] is that any nonzero data path in the trellis or state diagram produces $K - 1$ consecutive branches with all zero code symbols.

We observe also that for binary-tree ($R = 1/n$) codes, if each adder of the coder has an even number of connections, then the self loop corresponding to the all ones (data) state will have zero weight and consequently the code will be catastrophic.

The main advantage of a systematic code is that it can never be catastrophic, since each closed loop must contain at least one branch generated by a nonzero data bit and thus having a nonzero code symbol. Still it can be shown [23] that only a small fraction of nonsystematic codes is catastrophic (in fact, $1/(2^n - 1)$ for binary-tree $R = 1/n$ codes). We note further that if catastrophic errors are ignored, nonsystematic codes with even larger free distance than those of Table I exist.

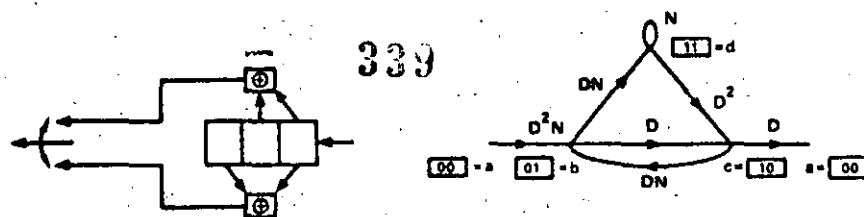


Fig. 14. Coder displaying catastrophic error propagation.

X. PERFORMANCE BOUNDS FOR BEST CONVOLUTIONAL CODES FOR GENERAL MEMORYLESS CHANNELS AND COMPARISON WITH BLOCK CODES

We begin by considering the path structure of a binary-tree¹⁴ ($b = 1$) convolutional code of any constraint K , independent of the specific coder used. For this purpose we need only determine $T(L)$ the generating function for the state diagram with each branch labeled merely by L so that the exponent of each term of the infinite series expansion of $T(L)$ determines the length over which an incorrect path differs from the correct path before merging with it at a given node level. (See Fig. 7 and (2) with $D = N = 1$).

After some manipulation of the state-transition matrix of the state diagram of a binary-tree convolutional code of constraint length K , it is shown in Appendix I¹⁵ that

$$T(L) = \frac{L^K(1-L)}{1-2L+L^K} < \frac{L^K}{1-2L} \\ = L^K(1+2L+4L^2+\dots+2^iL^i+\dots) \quad (50)$$

where the inequality indicates that more paths are being counted than actually exist. The expression (50) indicates that of the paths merging with the correct path at a given node level there is no more than one of length K , no more than two of length $K+1$, no more than three of length $K+2$, etc.

We have purposely avoided considering the actual code or coder configuration so that the preceding expressions are valid for all binary-tree codes of constraint length K . We now extend our class of codes to include time-varying convolutional codes. A time-varying coder is one in which the tap positions may be changed after each shift of the bits in the register. We consider the ensemble of all possible time-varying codes, which includes as a subset the ensemble of all fixed codes, for a given constraint length K . We further impose a uniform probabilistic measure on all codes in this ensemble by randomly reselecting each tap position after each shift of the register. This can be done by hypothetically flipping a coin nK times after each shift, once for each stage of the register and for each of the n adders. If the out-

come is a head we connect the particular stage to the particular adder; if it is a tail we do not. Since this is repeated for each new branch, the result is that for each branch of the trellis the code sequence is a random binary n -dimensional vector. Furthermore, it can be shown that the distribution of these random code sequences is the same for each branch at each node level except for the all zeros path, which must necessarily produce the all zeros code sequence on each branch. To avoid treating the all zeros path differently, we ensure statistical uniformity by requiring further that after each shift a random binary n -dimensional vector be added to each branch¹⁶ and that this also be reselected after each shift. (This additional artificiality is unnecessary for input-binary channels but is required to prove our result for general memoryless channels). Further details of this procedure are given in Viterbi [9].

We now seek a bound on the average error probability of this ensemble of codes relative to the measure (random-selection process) imposed. We begin by considering the probability that after transmission over a memoryless channel the metric of one of the fewer than 2^k paths merging with the correct path after differing in $K+k$ branches, is greater than the correct metric. Let \mathbf{x}_i be the correct (transmitted) sequence and \mathbf{x}'_i an incorrect sequence for the i th branch of the two paths. Then following the argument which led to (37) we have that the probability that the given incorrect path may cause an error is bounded by

$$P_{K+k}(\mathbf{x}, \mathbf{x}') < \prod_{i=1}^{K+k} \sum_{\mathbf{y}_i} P(\mathbf{y}_i | \mathbf{x}_i)^{1/2} P(\mathbf{y}_i | \mathbf{x}'_i)^{1/2} \quad (51)$$

where the product is over all $K+k$ branches in the path. If we now average over the ensemble of codes constructed above we obtain

$$\bar{P}_{K+k} < \prod_{i=1}^{K+k} \sum_{\mathbf{x}_i} \sum_{\mathbf{x}'_i} \sum_{\mathbf{y}_i} q(\mathbf{x}_i) P(\mathbf{y}_i | \mathbf{x}_i)^{1/2} q(\mathbf{x}'_i) P(\mathbf{y}_i | \mathbf{x}'_i)^{1/2} \quad (52)$$

where $q(\mathbf{x})$ is the measure imposed on the code symbols of each branch by the random selection, and because of the statistical uniformity of all branches we have

$$\bar{P}_{K+k} < \left| \sum_{\mathbf{y}} \left| \sum_{\mathbf{x}} q(\mathbf{x}) P(\mathbf{y} | \mathbf{x})^{1/2} \right|^2 \right|^{K+k} = 2^{-(K+k)hR} \quad (53)$$

¹⁴ Although for clarity all results will be derived for $b = 1$, the extension to $b > 1$ is direct and the results will be indicated at the end of this Section.

¹⁵ This generating function can also be used to obtain error bounds for orthogonal convolutional codes all of whose branches have the same weight, as is shown in Appendix C.

¹⁶ The same vector \mathbf{z} added to all branches at a given node level.

where

$$R_0 \triangleq -\frac{1}{n} \log_2 \left\{ \sum_y \left[\sum_x q(\mathbf{x}) P(\mathbf{y} | \mathbf{x})^{1/2} \right]^2 \right\}. \quad (54)$$

Note that the random vectors \mathbf{x} and \mathbf{y} are n dimensional. If each symbol is transmitted independently on a memoryless channel, such as was the case in the channels of Sections VII-A and -B, (54) is reduced further to

$$R_0 = -\log_2 \left\{ \sum_y \left[\sum_x q(x) P(y | x)^{1/2} \right]^2 \right\} \quad (55)$$

where x and y are now scalar random variables associated with each code symbol. Note also that because of the statistical uniformity of the code, the results are independent of which path was transmitted and which incorrect path we are considering.

Proceeding as in Section VII, it follows that a union bound on the ensemble average of the first-event error probability is obtained by substituting \bar{P}_{K+k} for L^{K+k} in (50). Thus

$$\begin{aligned} \bar{P}_R &< \sum_{k=0}^{\infty} 2^k \bar{P}_{K+k} < \sum_{k=0}^{\infty} 2^k 2^{-(K+k)R_0/R} \\ &= \frac{2^{-KR_0/R}}{1 - 2^{-(R_0/R-1)}} \end{aligned} \quad (56)$$

where we have used the fact that since $b = 1$, $R = 1/n$ bits/symbol.

To bound the bit error probability we must weight each term of (56) by the number of bit errors for the corresponding incorrect path. This could be done by evaluating the transfer function $T(L, N)$ as in Section VII (see also Appendix I), but a simpler approach, which yields a simpler bound which is nearly as tight, is to recognize that an incorrectly chosen path which merges with the correct path after $K + k$ branches can produce no more than $k + 1$ bit errors. For, any path which merges with the correct path at a given level must be generated by data which coincides with the correct path data over the last $K - 1$ branches prior to merging, since only in this way can the coder register be filled with the same bits as the correct path, which is the condition for merging. Hence the number of incorrect bits due to a path which differs from the correct path in $K + k$ branches can be no greater than $K + k - (K - 1) = k + 1$.

Hence we may overbound \bar{P}_R by weighting the k th term of (56) by $k + 1$, which results in

$$\bar{P}_R < \sum_{k=0}^{\infty} (k + 1) 2^{-k(R_0/R-1)} 2^{-KR_0/R} = \frac{2^{-KR_0/R}}{[1 - 2^{-(R_0/R-1)}]^2} \quad (57)$$

The bounds of (56) and (57) are finite only for rates $R < R_0$, and R_0 can be shown to be always less than the channel capacity.

To improve on these bounds when $R > R_0$, we must improve on the union bound approach by obtaining a single bound on the probability that any one of the fewer than 2^k paths which differ from the correct path in $K + k$ branches has a metric higher than the correct path at a given node level. This bound, first derived by Gallager [5] for block codes, is always less than 2^k times the bound for each individual path. Letting $\bar{Q}_{K+k} \triangleq \Pr$ (any one of 2^k incorrect path metrics $>$ correct path metric), Gallager [5] has shown that its ensemble average for the code ensemble is bounded by

$$\bar{Q}_{K+k} < 2^{k\rho} 2^{-(K+k)E_0(\rho)} \quad (58)$$

where

$$E_0(\rho) = -\frac{1}{n} \log_2 \sum_y \left[\sum_x q(\mathbf{x}) p(\mathbf{y} | \mathbf{x})^{1/(1+\rho)} \right]^{1+\rho}, \quad 0 < \rho \leq 1 \quad (59)$$

where ρ is an arbitrary parameter which we shall choose to minimize the bound. It is easily seen that $E_0(0) = 0$, while $E_0(1) = R_0$, in which case $\bar{Q}_{K+k} = 2^k \bar{P}_{K+k}$, the ordinary union bound of (56). We bound the overall ensemble first-event error probability by the probability of the union of these composite events given by (58). Thus we find

$$\bar{P}_R < \sum_{k=0}^{\infty} \bar{Q}_{K+k} < \frac{2^{-KE_0(\rho)/R}}{1 - 2^{-(E_0(\rho)/R-\rho)}} \quad (60)$$

Clearly (60) reduces to (56) when $\rho = 1$.

To determine the bit error probability using this approach, we must recognize that \bar{Q}_{K+k} refers to 2^k different incorrect paths, each with a different number of incorrect bits. However, just as was observed in deriving (57), an incorrect path which differs from the correct path in $K + k$ branches prior to merging can produce at most $k + 1$ bit errors. Hence weighting the k th term of (60) by $k + 1$, we obtain

$$\begin{aligned} \bar{P}_R &< \sum_{k=0}^{\infty} (k+1) \bar{Q}_{K+k} < \sum_{k=0}^{\infty} (k+1) 2^{-k(E_0(\rho)/R-\rho)} 2^{-KE_0(\rho)/R} \\ &= \frac{2^{-KE_0(\rho)/R}}{[1 - 2^{-(E_0(\rho)/R-\rho)}]^2}, \quad 0 < \rho \leq 1. \end{aligned} \quad (61)$$

Clearly (61) reduces to (57) when $\rho = 1$.

Before we can interpret the results of (56), (57), (60), and (61) it is essential that we establish some of the properties of $E_0(\rho)$ ($0 < \rho \leq 1$) defined by (59). It can be shown [5], [14] that for any memoryless channel, $E_0(\rho)$ is a concave monotonic nondecreasing function as shown in Fig. 15 with $E_0(0) = 0$ and $E_0(1) = R_0$.

Where the derivative $E_0'(\rho)$ exists, it decreases with ρ and it follows easily from the definition that

$$\lim_{\rho \rightarrow 0} E_0'(\rho) = \frac{1}{n} \sum_y \sum_x q(\mathbf{x}) \log_2 \frac{P(\mathbf{y} | \mathbf{x})}{\sum_x q(\mathbf{x}) P(\mathbf{y} | \mathbf{x})} \quad (62)$$

$$= \frac{1}{n} J(X^*, Y^*) \triangleq C$$

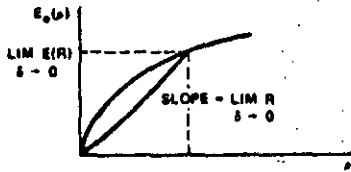


Fig. 15. Example of $E_0(\rho)$ function for general memoryless channel.

the mutual information of the channel¹⁷ where X^* and Y^* are the channel input and output spaces, respectively, for each branch sequence. Consequently, it follows that to minimize the bounds (60) and (61), we must make $\rho \leq 1$ as large as possible to maximize the exponent of the numerator, but at the same time we must ensure that

$$R < \frac{E_0(\rho)}{\rho}$$

in order to keep the denominator positive. Thus since $E_0(1) = R_0$ and $E_0(\rho) < R_0$, for $\rho < 1$, it follows that for $R < R_0$ and sufficiently large K we should choose $\rho = 1$, or equivalently use the bounds (56) and (57). We may thus combine all the above bounds into the expressions

$$\bar{P}_R < \frac{2^{-KK(R)/R}}{1 - 2^{-\delta(R)}} \tag{63}$$

$$\bar{P}_B < \frac{2^{-KK(R)/R}}{\{1 - 2^{-\delta(R)}\}^2} \tag{64}$$

where

$$E(R) = \begin{cases} R_0, & 0 \leq R < R_0 \\ E_0(\rho), & R_0 < R < C, \quad 0 < \rho \leq 1 \end{cases} \tag{65}$$

$$\delta(R) = \begin{cases} R_0/R - 1, & 0 < R < R_0 \\ E_0(\rho)/R - \rho, & R_0 \leq R < C, \quad 0 < \rho \leq 1. \end{cases} \tag{66}$$

To minimize the numerators of (63) and (64) for $R > R_0$ we should choose ρ as large as possible, since $E_0(\rho)$ is a nondecreasing function of ρ . However, we are limited by the necessity of making $\delta(R) > 0$ to keep the denominator from becoming zero. On the other hand, as the constraint length K becomes very large we may choose $\delta(R) = \delta$ very small. In particular, as δ approaches 0, (65) approaches

$$\lim_{\delta \rightarrow 0} E(R) = \begin{cases} R_0, & 0 < R < R_0 \\ E_0(\rho), & R_0 \leq R = E_0(\rho)/\rho < C, \\ & 0 < \rho \leq 1. \end{cases} \tag{67}$$

¹⁷ C can be made equal to the channel capacity by properly choosing the ensemble measure $q(x)$. For an input-binary channel the random binary convolutional coder described above achieves this. Otherwise a further transformation of the branch sequence into a smaller set of nonbinary sequences is required [5].

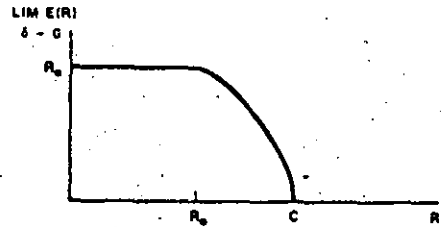


Fig. 16. Typical limiting value of exponent of (67).

Fig. 15 demonstrates the graphical determination of $\lim_{\delta \rightarrow 0} E(R)$ from $E_0(\rho)$.

It follows from the properties of $E_0(\rho)$ described, that for $R > R_0$, $\lim_{\delta \rightarrow 0} E(R)$ decreases from R_0 to 0 as R increases from R_0 to C , but that it remains positive for all rates less than C . The function is shown for a typical channel in Fig. 16.

It is particularly instructive to obtain specific bounds, in the limiting case, for the class of "very noisy" channels, which includes the BSC with $p = 1/2 - \gamma$ where $|\gamma| \ll 1$ and the biphasic modulated AWGN with $\epsilon/N_0 \ll 1$. For this class of channels it can be shown [5] that

$$E_0(\rho) = \frac{\rho C}{1 + \rho} \tag{68}$$

and consequently $R_0 = E_0(1) = C/2$. (For the BSC, $C = \gamma^2/2 \ln 2$ while for the AWGN, $C = \epsilon/N_0 \ln 2$.)

For the very noisy channel, suppose we let $\rho = C/R - 1$, so that using (68) we obtain $E_0(\rho) = C - R$. Then in the limit as $\delta \rightarrow 0$ (65) becomes for a very noisy channel

$$\lim_{\delta \rightarrow 0} E(R) = \begin{cases} C/2, & 0 \leq R \leq C/2 \\ C - R, & C/2 \leq R \leq C \end{cases} \tag{69}$$

This limiting form of $E(R)$ is shown in Fig. 17.

The bounds (63) and (64) are for the average error probabilities of the ensemble of codes relative to the measure induced by random selection of the time-varying coder tap sequences. At least one code in the ensemble must perform better than the average. Thus the bounds (63) and (64) hold for the best time-varying binary-tree convolutional coder of constraint length K . Whether there exists a fixed convolutional code with this performance is an unsolved problem. However, for small K the results of Section VII seem to indicate that these bounds are valid also for fixed codes.

To determine the tightness of the upper bounds, it is useful to have lower bounds for convolutional code error probabilities. It can be shown [9] that for all $R < C$

$$P_B \geq P_E > 2^{-K[E_L(R)/R - \delta(K)]} \tag{70}$$

where

$$E_L(R) = E_0(\rho), \quad 0 \leq \rho < \infty, \quad 0 \leq R \leq C \tag{71}$$

$$R = E_0(\rho)/\rho$$

and $\delta(K) \rightarrow 0$ as $K \rightarrow \infty$. Comparison of the parametric

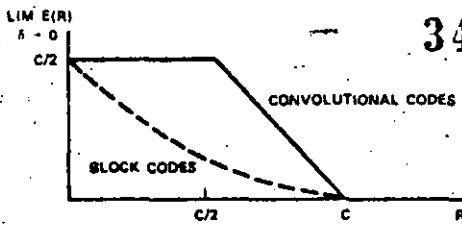


Fig. 17. Limiting values of $E(R)$ for very noisy channels.

equations (67) with (71), shows that

$$E_L(R) = \lim_{\rho \rightarrow 0} E(R)$$

for $R > R_0$ but is greater for low rates.

For very noisy channels, it follows easily from (71) and (68) that

$$E_L(R) = C - R, \quad 0 \leq R \leq C.$$

Actually, however, tighter lower bounds for $R < C/2$ (Viterbi [9]) show that for very noisy channels

$$E_L(R) = \begin{cases} C/2, & 0 \leq R \leq C/2 \\ C - R, & C/2 \leq R < C, \end{cases} \quad (72)$$

which is precisely the result of (69) or of Fig. 17. It follows that, at least for very noisy channels, the exponential bounds are asymptotically exact.

All the results derived in this section can be extended directly to nonbinary ($b > 1$) codes. It is easily shown (Viterbi [9]) that the same results hold with $R = b/n$, R_0 and $E_b(\rho)$ multiplied by b , and all event probability upper bounds multiplied by $2^b - 1$, and bit probability upper bounds multiplied by $(2^b - 1)/b$.

Clearly, the ensemble of codes considered here is non-systematic. However, by a modification of the arguments used here, Bucher and Heller [19] restricted the ensemble to systematic time-varying convolutional codes (i.e., codes for which b code symbols of each branch correspond to the data which generates the branch) and obtained all the above results modified only to the extent that the exponents $E(R)$ and $E_L(R)$ are multiplied by $1 - R$. (See also Section VIII.)

Finally, it is most revealing to compare the asymptotic results for the best convolutional codes of a given constraint length with the corresponding asymptotic results for the best block codes of a given block length. Suppose that K bits are coded into a block code of length N so that $R = K/N$ bits/code symbol. Then it can be shown (Gallager [5]; Shannon *et al.* [8]) that for the best block code, the bit error probability is bounded above and below by

$$2^{-K(E_L(R)/R + o(K))} < P_B < 2^{-K(E_b(R)/R)} \quad (73)$$

where

$$E_b(R) = \text{Max}_{0 \leq \rho \leq 1} [E_b(\rho) - \rho R]$$

$$E_L(R) \leq \text{Max}_{0 \leq \rho \leq 1} [E_b(\rho) - \rho R]$$

Both $E_b(R)$ and $E_{L,b}(R)$ are functions of R which for all $R > 0$ are less than the exponents $E(R)$ and $E_L(R)$ for convolutional codes [9]. In particular, for very noisy channels they both become [5]

$$E_b(R) = E_{L,b}(R) = \begin{cases} C/2 - R \\ (\sqrt{C} - \sqrt{R})^2 \end{cases} \quad (74)$$

This is plotted as a dotted curve in Fig. 17.

Thus it is clear by comparing the magnitudes of the negative exponents of (73) and (64) that, at least for very noisy channels, a convolutional code performs much better asymptotically than the corresponding block code of the same order of complexity. In particular at $R = C/2$, the ratio of exponents is 5.8, indicating that to achieve equivalent performance asymptotically the block length must be over five times the constraint length of the convolutional code. Similar degrees of relative performance can be shown for more general memoryless channels [9].

More significant from a practical viewpoint, for short constraint lengths also, convolutional codes considerably outperform block codes of the same order of complexity.

XI. PATH MEMORY TRUNCATION METRIC QUANTIZATION AND SYNCHRONIZATION

A major problem which arises in the implementation of a maximum likelihood decoder is the length of the path history which must be stored. In our previous discussion we ignored this important point and therefore implicitly assumed that all past data would be stored. A final decision was made by forcing the coder into a known (all zeros) state. We now remove this impractical condition. Suppose we truncate the path memories after M bits (branches) have been accumulated, by comparing all 2^K metrics for a maximum and deciding on the bit corresponding to that path (out of 2^K) with the highest metric M branches forward. If M is several times as large as K , the additional bit errors introduced in this way are very few, as we shall now demonstrate using the asymptotic results of the last section.

An additional bit error may occur due to memory truncation after M branches, if the bit selected is from an incorrect path which differed from the correct path M branches back and which has a higher metric, but which would ultimately be eliminated by the maximum likelihood decoder. But for a binary-tree code there can be no more than 2^M distinct paths which differ from the correct path M branches back. Of these we need concern ourselves only with those which have not merged with the correct path in the intervening nodes. As was originally shown by Forney [12], using the ensemble arguments of Section X we may bound the average probability of this event by [see (58)]

$$P_B < 2^{-M E_b(R)} \leq 2^{-M E_L(R)} \quad 0 < \rho \leq 1 \quad (75)$$

To minimize this bound we should maximize the exponent $E_b(\rho)/R - \rho$ with respect to ρ on the unit interval. But this yields exactly $E_b(R)$, the upper bound exponent of (73) for block codes. Thus

$$P_e < 2^{-ME_b(R)/R} \quad (76)$$

where $E_b(R)$ is the block coding exponent.

We conclude therefore that the memory truncation error is less than the bit error probability bound without truncation, provided the bound of (76) is less than the bound of (64). This will certainly be assured if

$$ME_b(R) > KE(R). \quad (77)$$

For very noisy channels we have from (69) and (74) or Fig. 17, that

$$\frac{M}{K} > \begin{cases} \frac{1}{1 - 2R/C}, & 0 \leq R \leq C/4 \\ \frac{1}{2(1 - \sqrt{R/C})^2}, & C/4 \leq R \leq C/2 \\ \frac{1 - R/C}{(1 - \sqrt{R/C})^2}, & C/2 < R < C. \end{cases}$$

For example, at $R = C/2$ this indicates that it suffices to take $M > (5.8)K$.

Another problem faced by a system designer is the amount of storage required by the metrics (or log-likelihood functions) for each of the 2^k paths. For a BSC this poses no difficulty since the metric is just the Hamming distance which is at most n , the number of code symbols, per branch. For the AWGN, on the other hand, the optimum metric is a real number, the analog output of a correlator, matched filter, or integrate-and-dump circuit. Since digital storage is generally required, it is necessary to quantize this analog metric. However, once the components y_{ik} of the optimum metric of (5), which are the correlator outputs, have been quantized to Q levels, the channel is no longer an AWGN channel. For biphasic modulation, for example, it becomes a binary input Q -ary output discrete memoryless channel, whose transition probabilities are readily calculated as a function of the energy-to-noise density and the quantization levels. The optimum metric is not obtained by replacing y_{ik} by its quantized value $Q(y_{ik})$ in (5) but rather it is the log-likelihood function $\log P(\mathbf{y} | \mathbf{x}^{(m)})$ for the binary-input Q -ary-output channel.

Nevertheless, extensive simulation [24] indicates that for 8-level quantization even use of the suboptimal metric $\sum_k Q(y_{ik})x_{ik}^{(m)}$ results in a degradation of no more than 0.25 dB relative to the maximum likelihood decoder for the unquantized AWGN, and that use of the optimum metric is only negligibly superior to this. However, this is not the case for sequential decoding, where the difference

in performance between optimal and suboptimal metrics is significant [11].

In a practical system other considerations than error performance for a given degree of decoder complexity often dictate the selection of a coding system. Chief among these are often the synchronization requirements. Convolutional codes utilizing maximum likelihood decoding are particularly advantageous in that no block synchronization is ever required. For block codes, decoding cannot begin until the initial point of each block has been located. Practical systems often require more complexity in the synchronization system than in the decoder. On the other hand, as we have by now amply illustrated, a maximum likelihood decoder for a convolutional code does not require any block synchronization because the coder is free running (i.e., it performs identical operations for each successive input bit and does not require that K bits be input before generating an output). Furthermore, the decoder does not require knowledge of past inputs to start decoding; it may as well assume that all previous bits were zeros. This is not to say that initially the decoder will operate as well, in the sense of error performance, as if the preceding bits of the correct path were known. On the other hand, consider a decoder which starts with an initially known path but makes an error at some point and excludes the correct path. Immediately thereafter it will be operating as if it had just been turned on with an unknown and incorrectly chosen previous path history. That this decoder will recover and stop making errors within a finite number of branches follows from our previous discussions in which it was shown that, other than for catastrophic codes, error sequences are always finite. Hence our initially unsynchronized decoder will operate just like a decoder which has just made an error and will thus always achieve synchronization and generally will produce correct decisions after a limited number of initial errors. Simulations have demonstrated that synchronization generally takes no more than four or five constraint lengths of received symbols.

Although, as we have just shown, branch synchronization is not required, code symbol synchronization within a branch is necessary. Thus, for example, for a binary-tree rate $R = 1/2$ code, we must resolve the two-way ambiguity as to where each two code-symbol branch begins. This is called node synchronization. Clearly if we make the wrong decisions, errors will constantly be made thereafter. However, this situation can easily be detected because the mismatch will cause *all* the path metrics to be small, since in fact there will not be any correct path in this case. We can thus detect this event and change our decision as to node synchronization (cf. Heller and Jacobs [24]). Of course, for an $R = 1/n$ code, we may have to repeat our choice n times, once for each of the symbols on a branch, but since n represents the redundancy factor or bandwidth expansion, practical systems rarely use $n > 4$.

XII. OTHER DECODING ALGORITHMS FOR CONVOLUTIONAL CODES

This paper has treated primarily maximum likelihood decoding of convolutional codes. The reason for this was two-fold: 1) maximum likelihood decoding is closely related to the structure of convolutional codes and its consideration enhances our understanding of the ultimate capabilities, performance, and limitation of these codes; 2) for reasonably short constraint lengths ($K < 10$) its implementation is quite feasible¹⁸ and worthwhile because of its optimality. Furthermore for $K \leq 6$, the complexity of maximum likelihood decoding is sufficiently limited that a completely parallel implementation (separate metric calculators) is possible. This minimizes the decoding time per bit and affords the possibility of extremely high decoding speeds [24].

Longer constraint lengths are required for extremely low error probabilities at high rates. Since the storage and computational complexity are proportional to 2^K , maximum likelihood decoders become impractical for $K > 10$. At this point *sequential decoding* [2], [4], [6] becomes attractive. This is an algorithm which sequentially searches the code tree in an attempt to find a path whose metric rises faster than some predetermined, but variable, threshold. Since the difference between the correct path metric and any incorrect path metric increases with constraint length, for large K generally the correct path will be found by this algorithm. The main drawback is that the number of incorrect path branches, and consequently the computation complexity, is a random variable depending on the channel noise. For $R < R_0$, it is shown that the average number of incorrect branches searched per decoded bit is bounded [6], while for $R > R_0$ it is not; hence R_0 is called the computational cutoff rate. To make storage requirements reasonable, it is necessary to make the decoding speed (branches/s) somewhat larger than the bit rate, thus somewhat limiting the maximum bit rate capability. Also, even though the average number of branches searched per bit is finite, it may sometimes become very large, resulting in a storage overflow and consequently relatively long sequences being erased. The stack sequential decoding algorithm [7], [18] provides a very simple and elegant presentation of the key concepts in sequential decoding, although the Fano algorithm [4] is generally preferable practically.

For a number of reasons, including buffer size requirements, computation speed, and metric sensitivity, sequential decoding of data transmitted at rates above about 100 K bits/s is practical only for hard-quantized binary received data (that is, for channels in which a hard decision -0 or 1- is made for each demodulated symbol). For the biphasic modulated AWGN channel, of course, hard quantization (2 levels or 1 bit) results in an efficiency loss of approximately 2 dB compared with soft

quantization (8 or more levels—3 or more bits). On the other hand, with maximum likelihood decoding, by employing a parallel implementation, short constraint length codes ($K \leq 6$) can be decoded at very high data rates (10 to 100 Mbits/s) even with soft quantization. In addition, the insensitivity to metric accuracy and simplicity of synchronization render maximum likelihood decoding generally preferable when moderate error probabilities are sufficient. In particular, since sequential decoding is limited by the overflow problem to operate at code rates somewhat below R_0 , it appears that for the AWGN the crossover point above which maximum likelihood decoding is preferable to sequential decoding occurs at values of P_b somewhere between 10^{-3} and 10^{-5} , depending on the transmitted data rate. As the data rate increases the P_b crossover point decreases.

A third technique for decoding convolutional codes is known as *feedback decoding*, with threshold decoding [3] as a subclass. A feedback decoder basically makes a decision on a particular bit or branch in the decoding tree or trellis based on the received symbols for a limited number of branches beyond this point. Even though the decision is irrevocable, for limited constraint lengths (which are appropriate considering the limited number of branches involved in a decision) errors will propagate only for moderate lengths. When transmission is over a binary symmetric channel, by employing only codes with certain algebraic (orthogonal) properties, the decision on a given branch can be based on a linear function of the received symbols, called the *syndrome*, whose dimensionality is equal to the number of branches involved in the decision. One particularly simple decision criterion based on this syndrome, referred to as *threshold decoding*, is mechanizable in a very inexpensive manner. However, feedback decoders in general, and threshold decoders in particular, have an error-correcting capability equivalent to very short constraint length codes and consequently do not compare favorably with the performance of maximum likelihood or sequential decoding.

However, feedback decoders are particularly well suited to correcting error bursts which may occur in fading channels. Burst errors are generally best handled by using interleaved codes; that is, employing L convolutional codes so that the j th, $(L + j)$ th, $(2L + j)$ th, etc., bits are encoded into one code for each $j = 0, 1, \dots, L - 1$. This will cause any burst of length less than L to be broken up into random errors for the L independently operating decoders. Interleaving can be achieved by simply inserting $L - 1$ stage delay lines between stages of the convolutional encoder; the resulting single encoder then generates the L interleaved codes. The significant advantage of a feedback or threshold decoder is that the same technique can be employed in the decoder resulting in a single (time-shared) decoder rather than L decoders, providing feasible implementations for hard-quantized channels, even for protection against error bursts of thousands of bits. Details of feedback decoding

¹⁸ Performing metric calculations and comparisons serially.

are treated extensively in Massey [3], Gallager [14], and Lucky *et al.* [16].

APPENDIX I

GENERATING FUNCTION FOR STRUCTURE OF A BINARY-TREE CONVOLUTIONAL CODE FOR ARBITRARY K AND ERROR BOUNDS FOR ORTHOGONAL CODES

We derive here the distance-invariant ($D = 1$) generating function $T(L, N)$ for any binary tree ($b = 1$) convolutional code of arbitrary constraint length K . It is most convenient in the general case to begin with the finite-state machine state-transition matrix for the linear equations among the state (node) variables. We exhibit this in terms of N and L for a $K = 4$ code as follows:

$$\begin{bmatrix} 1 & 0 & 0 & -NL & 0 \\ -L & 1 & 0 & 0 & -L \\ -NL & 0 & 1 & 0 & -NL \\ 0 & -L & 0 & 1 & 0 \\ 0 & -NL & 0 & 0 & 1 \\ 0 & 0 & -L & 0 & 0 \\ 0 & 0 & -NL & 0 & 0 \end{bmatrix} \begin{bmatrix} X_{001} \\ X_{010} \\ X_{011} \\ X_{100} \\ X_{101} \\ X_{110} \\ X_{111} \end{bmatrix} = \begin{bmatrix} NL \\ 0 \\ 0 \\ 0 \\ 0 \\ 0 \\ 0 \end{bmatrix} \quad (78)$$

This pattern can be easily seen to generalize to a $2^{K-1} - 1$ dimensional square matrix of this form for any binary-tree code of constraint length K , and in general the generating function

$$T(L, N) = LX_{100\dots 0},$$

where $100 \dots 0$ contains $(K - 2)$ zeros. (79)

From this general pattern it is easily shown that the matrix can be reduced to a dimension of 2^{K-2} . First combining adjacent rows, from the second to the last, pairwise, one obtains the set of $2^{K-2} - 1$ relations

$$NX_{j_1 j_2 \dots j_{K-2} 0} = X_{j_1 j_2 \dots j_{K-2} 1} \quad (80)$$

where j_1, j_2, \dots, j_{K-2} runs over all binary vectors except for the all zeros. Substitution of (80) into (78) yields a 2^{K-2} -dimensional matrix equation. The result for $K = 4$ is

$$\begin{bmatrix} 1 & 0 & -L & 0 \\ -NL & 1 & -NL & 0 \\ 0 & -L & 1 & -L \\ 0 & -NL & 0 & 1 - NL \end{bmatrix} \begin{bmatrix} X_{001} \\ X_{011} \\ X_{101} \\ X_{111} \end{bmatrix} = \begin{bmatrix} NL \\ 0 \\ 0 \\ 0 \end{bmatrix} \quad (81)$$

Defining the new variable

$$X'_{00\dots 01} = NL X_{00\dots 01} + X_{00\dots 11} \quad (82)$$

(which corresponds to adding the second row to NL

times the first), we obtain finally a $2^{K-2} - 1$ dimensional matrix equation, which for $K = 4$ is

$$\begin{bmatrix} 1 & -N(L + L^2) & 0 \\ -L & 1 & -L \\ -NL & 0 & 1 - NL \end{bmatrix} \begin{bmatrix} X'_{001} \\ X_{101} \\ X_{111} \end{bmatrix} = \begin{bmatrix} N^2 L^2 \\ 0 \\ 0 \end{bmatrix} \quad (83)$$

Note that (83) is the same as (78) for K reduced by unity, but with modifications in two places, both in the first row; namely, the first component on the right side is squared, and the middle term of the first row is reduced by an amount NL^2 . Although we have given the explicit result only for $K = 4$, it is easily seen to be valid for any K .

$$\begin{bmatrix} 0 & 0 \\ 0 & 0 \\ 0 & 0 \\ -L & 0 \\ -NL & 0 \\ 1 & -L \\ 0 & 1 - NL \end{bmatrix} \begin{bmatrix} X_{001} \\ X_{010} \\ X_{011} \\ X_{100} \\ X_{101} \\ X_{110} \\ X_{111} \end{bmatrix} = \begin{bmatrix} NL \\ 0 \\ 0 \\ 0 \\ 0 \\ 0 \\ 0 \end{bmatrix} \quad (78)$$

Since in all respects, except these two, the matrix after this sequence of reductions is the same as the original but with its dimension reduced corresponding to a reduction of K by unity, we may proceed to perform this sequence of reductions again. The steps will be the same except that now in place of (80), we have

$$NX_{j_1 j_2 \dots j_{K-3} 01} = X_{j_1 j_2 \dots j_{K-3} 11} \quad (80')$$

and in place of (82)

$$X''_{00\dots 01} = NL X'_{00\dots 01} + X_{00\dots 11} \quad (82')$$

while in place of (81) the right of center term of the first row is $-(L + L^2)$ and the first component on the right side is $N^2 L^2$. Similarly in place of (83) the center term of the first row is $-N(L + L^2 + L^3)$ and the first component on the right side is $N^3 L^3$.

Performing this sequence of reductions $K - 2$ times in all, but omitting the last step—leading from (81) to (83)—in the last reduction, the original $2^{K-1} - 1$ equations are reduced in the general case to the two equations

$$\begin{bmatrix} 1 & -(L + L^2 + \dots + L^{K-2}) \\ -NL & 1 - NL \end{bmatrix} \begin{bmatrix} X_{00\dots 01}^{(K-3)} \\ X_{11\dots 11} \end{bmatrix} = \begin{bmatrix} (NL)^{K-2} \\ 0 \end{bmatrix} \quad (84)$$

whence it follows that

346

$$X_{11\dots 11} = \frac{(NL)^{K-1}}{1 - N(L + L^2 + \dots + L^{K-1})} \quad (85)$$

Applying (79) and the $K - 2$ extensions of (80) and (80') we find

$$\begin{aligned} T(L, N) &= LX_{100\dots 00} = LN^{-1}X_{100\dots 01} \\ &= LN^{-2}X_{100\dots 011} = \dots = LN^{-(K-2)}X_{11\dots 11} \\ &= \frac{NL^K}{1 - N(L + L^2 + \dots + L^{K-1})} \\ &= \frac{NL^K(1 - L)}{1 - L(1 + N) + NL^K} \end{aligned} \quad (86)$$

If we require only the path length structure, and not the number of bit errors corresponding to any incorrect path, we may set $N = 1$ in (86) and obtain

$$T(L) = \frac{L^K}{1 - (L + L^2 + \dots + L^{K-1})} = \frac{L^K(1 - L)}{1 - 2L + L^K} \quad (87)$$

If we denote as an upper bound an expression which is the generating function of more paths than exist in our state diagram, we have

$$T(L) < \frac{L^K}{1 - 2L} \quad (88)$$

As an additional application of this generating function technique, we now obtain bounds on P_E and P_b for the class of orthogonal convolutional (tree) codes introduced by Viterbi [10]. For this class of codes, to each of the 2^K branches of the K -state diagram there corresponds one of 2^K orthogonal signals. Given that each signal is orthogonal to all others in $n \geq 1$ dimensions, corresponding to n channel symbols or transmission times (as, for example, if each signal consists of n different pulses out of 2^{Kn} possible positions), then the weight of each branch is n . Consequently, if we replace L , the path length enumerator, by D^n in (86) we obtain for orthogonal codes

$$T(D, N) = \frac{ND^{nK}(1 - D^n)}{1 - D^n(1 + N) + ND^{nK}} \quad (89)$$

Then using (48) and (49), the first-event error probability for orthogonal codes is bounded by

$$P_E < \frac{D_0^{nK}(1 - D_0^n)}{1 - 2D_0^n + D_0^{nK}} < \frac{D_0^{nK}(1 - D_0^n)}{1 - 2D_0^n} \quad (90)$$

and the bit error probability bound is

$$\begin{aligned} P_b &< \left. \frac{dT(N, D)}{dN} \right|_{N=1, D=D_0} \\ &= \frac{D_0^{nK}(1 - D_0^n)^2}{(1 - 2D_0^n + D_0^{nK})^2} < \frac{D_0^{nK}(1 - D_0^n)^2}{(1 - 2D_0^n)^2} \end{aligned} \quad (91)$$

where D_0 is a function of the channel transition probabilities or energy-to-noise ratio and is given by (46).

ACKNOWLEDGMENT

The author gratefully acknowledges the considerable stimulation he has received over the course of writing the several versions of this paper from Dr. J. A. Heller, whose recent work strongly complements and enhances this effort, for numerous discussions and suggestions and for his assistance in its presentation at the Linkabit Corporation "Seminars on Convolutional Codes." This tutorial approach owes part of its origin to Dr. G. D. Forney, Jr., whose imaginative and perceptive reinterpretation of my original work has aided immeasurably in rendering it more comprehensible. Also, thanks are due to Dr. J. K. Omura for his careful and detailed reading and correction of the manuscript during his presentation of this material in the UCLA graduate course on information theory.

REFERENCES

- [1] P. Elias, "Coding for noisy channels," in *1955 IRE Nat. Conv. Rec.*, vol. 3, pt. 4, pp. 37-46.
- [2] J. M. Wozencraft, "Sequential decoding for reliable communication," in *1957 IRE Nat. Conv. Record*, vol. 5, pt. 2, pp. 11-25.
- [3] J. L. Massey, *Threshold Decoding*. Cambridge, Mass.: M.I.T. Press, 1963.
- [4] R. M. Fano, "A heuristic discussion of probabilistic decoding," *IEEE Trans. Inform. Theory*, vol. IT-9, Apr. 1963, pp. 64-74.
- [5] R. G. Gallager, "A simple derivation of the coding theorem and some applications," *IEEE Trans. Inform. Theory*, vol. IT-11, Jan. 1965, pp. 3-18.
- [6] J. M. Wozencraft and I. M. Jacobs, *Principles of Communication Engineering*. New York: Wiley, 1965.
- [7] K. S. Zangirov, "Some sequential decoding procedures," *Probl. Peredach Inform.*, vol. 2, no. 4, 1966, pp. 13-25.
- [8] C. E. Shannon, R. G. Gallager, and E. R. Berlekamp, "Lower bounds to error probability for coding on discrete memoryless channels," *Inform. Contr.*, vol. 10, 1967, pt. I, pp. 65-103, pt. II, pp. 522-552.
- [9] A. J. Viterbi, "Error bounds for convolutional codes and an asymptotically optimum decoding algorithm," *IEEE Trans. Inform. Theory*, vol. IT-13, Apr. 1967, pp. 260-269.
- [10] —, "Orthogonal tree codes for communication in the presence of white Gaussian noise," *IEEE Trans. Commun. Technol.*, vol. COM-15, April 1967, pp. 238-242.
- [11] I. M. Jacobs, "Sequential decoding for efficient communication from deep space," *IEEE Trans. Commun. Technol.*, vol. COM-15, Aug. 1968, pp. 492-501.
- [12] G. D. Forney, Jr., "Coding system design for advanced solar missions," submitted to NASA Ames Res. Ctr. by Codex Corp., Watertown, Mass., Final Rep., Contract NAS2-3637, Dec. 1967.
- [13] J. L. Massey and M. K. Sain, "Inverses of linear sequential circuits," *IEEE Trans. Comput.*, vol. C-17, Apr. 1968, pp. 330-337.
- [14] R. G. Gallager, *Information Theory and Reliable Communication*. New York: Wiley, 1968.
- [15] T. N. Morrissey, "Analysis of decoders for convolutional codes by stochastic sequential machine methods," Univ. Notre Dame, Notre Dame, Ind., Tech. Rep. EE-682, May 1968.
- [16] R. W. Lucky, J. Salz, and E. J. Weldon, *Principles of Data Communication*. New York: McGraw-Hill, 1968.

- 772
- [17] J. K. Omura, "On the Viterbi decoding algorithm," *IEEE Trans. Inform. Theory*, vol. IT-15, Jan. 1969, pp. 177-179.
- [18] F. Jelinek, "Fast sequential decoding algorithm using a stack," *IBM J. Res. Dev.*, vol. 13, no. 6, Nov. 1969, pp. 675-685.
- [19] E. A. Bueher and J. A. Heller, "Error probability bounds for systematic convolutional codes," *IEEE Trans. Inform. Theory*, vol. IT-16, Mar. 1970, pp. 219-224.
- [20] J. P. Odenwaller, "Optimal decoding of convolutional codes," Ph.D. dissertation, Dep. Syst. Sci., Sch. Eng. Appl. Sci., Univ. California, Los Angeles, 1970.
- [21] G. D. Forney, Jr., "Coding and its application in space communications," *IEEE Spectrum*, vol. 7, June 1970, pp. 47-53.
- [22] —, "Convolutional codes I: Algebraic structure," *IEEE Trans. Inform. Theory*, vol. IT-16, Nov. 1970, pp. 720-738; "II: Maximum likelihood decoding," and "III: Sequential decoding," *IEEE Trans. Inform. Theory*, to be published.
- [23] W. J. Rosenberg, "Structural properties of convolutional codes," Ph.D. dissertation, Dep. Syst. Sci., Sch. Eng. Appl. Sci., Univ. California, Los Angeles, 1971.
- [24] J. A. Heller and I. M. Jacobs, "Viterbi decoding for satellite and space communication," this issue, pp. 835-848.
- [25] A. R. Cohen, J. A. Heller, and A. J. Viterbi, "A new coding technique for asynchronous multiple access communication," this issue, pp. 849-855.



Andrew J. Viterbi (S'54-M'58-SM'63) was born in Bergamo, Italy, on March 9, 1935. He received the B.S. and M.S. degrees in electrical engineering from the Massachusetts Institute of Technology, Cambridge, in 1957, and the Ph.D. degree in electrical engineering from the University of Southern California, Los Angeles, in 1962.

While attending M.I.T., he participated in the cooperative program at the Raytheon Company. In 1957 he joined the Jet Propulsion Laboratory where he became a Research Group Supervisor in the Communications Systems Research Section. In 1963 he joined the faculty of the University of California, Los Angeles, as an Assistant Professor. In 1965 he was promoted to Associate Professor and in 1969 to Professor of Engineering and Applied Science. He was a cofounder in 1968 of Linkabit Corporation of which he is presently Vice President.

Dr. Viterbi is a member of the Editorial Boards of the *PROCEEDINGS OF THE IEEE* and of the journal *Information and Control*. He is a member of Sigma Xi, Tau Beta Pi, and Eta Kappa Nu and has served on several governmental advisory committees and panels. He is the coauthor of a book on digital communication and author of another on coherent communication, and he has received three awards for his journal publications.

Burst-Correcting Codes for the Classic Bursty Channel

G. DAVID FORNEY, JR., MEMBER, IEEE

Abstract—The purpose of this paper is to organize and clarify the work of the past decade on burst-correcting codes. Our method is, first, to define an idealized model, called the classic bursty channel, toward which most burst-correcting schemes are explicitly or implicitly aimed; next, to bound the best possible performance on this channel; and, finally, to exhibit classes of schemes which are asymptotically optimum and serve as archetypes of the burst-correcting codes actually in use. In this light we survey and categorize previous work on burst-correcting codes. Finally, we discuss qualitatively the ways in which real channels fail to satisfy the assumptions of the classic bursty channel, and the effects of such failures on the various types of burst-correcting schemes. We conclude by comparing forward-error-correction to the popular alternative of automatic repeat-request (ARQ).

INTRODUCTION

MOST WORK in coding theory has been addressed to efficient communication over memoryless channels. While this work has been directly applicable to space channels [1], it has been of little use on all other real channels, where errors tend to occur in bursts. The use of interleaving to adapt random-error-correcting codes to bursty channels is frequently pro-

posed, but turns out to be a rather inefficient method of burst correction.

(Of the work that has gone into burst-correcting codes, the bulk has been devoted to finding codes capable of correcting all bursts of length B separated by guard spaces of length G . We call these zero-error burst-correcting codes. It has been realized in the past few years that this work too has been somewhat misdirected; for on channels for which such codes are suited, called in this paper *classic bursty channels*, much more efficient communication is possible if we require only that *practically all* bursts of length B be correctible.

The principal purpose of this paper is tutorial. In order to clarify the issues involved in the design of burst-correcting codes, we examine an idealized model, the classic bursty channel, on which bursts are never longer than B nor guard spaces shorter than G . We see that the inefficiency of zero-error codes is due to their operating at the zero-error capacity of the channel, approximately $(G - B)/(G + B)$, rather than at the true capacity, which is more like $G/(G + B)$. Operation at the true capacity is possible, however, if bursts can be treated as erasures; that is, if their locations can be identified. By the construction of some archetypal schemes in which short Reed-Solomon (RS) codes are used with interleavers, we arrive at asymptotically optimal codes of

Paper approved by the Communication Theory Committee of the IEEE Communication Technology Group for publication without oral presentation. Manuscript received May 10, 1971.
The author is with Codex Corporation, Newton, Mass. 02459.

Block-Coding Techniques for Reliable Data Transmission

ROBERT T. CHIEN, MEMBER IEEE

Abstract—Block coding has been in wide use in the error-detection and retransmission mode. It has also been used in some systems with a combination of forward error correction and retransmission techniques. In this paper, a brief survey and description of those block-coding techniques is given that are likely to be useful in practical data transmission systems.

I. INTRODUCTION

BLOCK-CODING TECHNIQUES have been in use in communication systems for many years. In most of these situations, block coding is used in conjunction with retransmission. In this mode a message is coded with a block check, usually employing a cyclic code; the coded message is transmitted; and a parity check is calculated at the receiver. If the check indicates the presence of an error, the message is repeated over the channel.

This basic scheme is very efficient and very economical provided that 1) the channel is not too noisy, 2) the errors are reasonably bunched, and 3) the feedback channel is available with reasonable cost. If any one of these three conditions is violated, the scheme is either going to be too expensive or the throughput will be unreasonably low. This is due to the fact that when error rate increases, or when they distribute more evenly, the number of blocks to be retransmitted will have to be increased. To reduce the number of retransmitted blocks one may employ shorter blocks, but that lowers the efficiency of the code. For a given reliability (computed through the probability of undetected errors) more percentage redundancy is needed for shorter block length.

Forward error correction would eliminate the need of a feedback channel. However, it has two drawbacks. First, to correct a large collection of error patterns is not only a very difficult task, it is also quite expensive. Second, the more errors are corrected from a block the lower is the confidence that is attached to that block. Thus, extensive forward error correction is not only costly it also reduces the system reliability. Due to these limitations forward error correction is seldom used in commercial systems.

The choice between retransmission and forward error

correction is perhaps too sharply presented. Given the situation it is clear that retransmission will be used whenever a feedback channel is available. In the case of many systems, however, a third situation does exist. Here, the feedback channel is available but the noisy forward channel reduces the throughput in retransmission to a low level. Yet the use of pure forward error correction is not acceptable either from the cost or reliability point of view. The proper answer to this situation could very well be a hybrid scheme which corrects a few errors and use error detection and retransmission as a back up. Such a system would normally have a higher reliability than the system with forward error correction and a higher throughput than the system with retransmission only.

The reason this hybrid scheme may appear attractive is due primarily to error distribution on real channels. In most real channels the errors have a tendency to bunch. That is, the presence of an error in a certain bit position increases the probability that the next bit may be in error. Hence, a burst error is more probable than an arbitrary error pattern with the same number of errors. It is also true that among the blocks that do have errors a vast majority will have only a few errors. It is not uncommon to find up to 80 or even 90 percent of the blocks containing error to contain only a single bit error. Allowing a burst of ten bits one may easily get all but one percent of error blocks remaining. Assuming a reasonable block length, these remaining blocks are typically blocks containing numerous errors signifying possibly a loss of synchronization. Retransmission is about the only practical way for taking care of these situations.

In this paper we give a brief survey of some of the recent techniques for forward error correction. Only those techniques which appear to have strong practical implications are covered. Particular emphasis are given to those systems which require a modest amount of redundancy and are susceptible to simple implementation.

II. BURST DETECTION AND CORRECTION

A. Burst Detection

The cyclic codes are described with polynomials. For our purpose the polynomials will have coefficient in the binary field, called Galois field of two elements ($GF(2)$) after the French mathematician Galois. The addition in $GF(2)$ is mod 2, i.e., $1 + 1 = 0$. The code polynomials are of length n , hence are polynomials of maximum

Paper approved by the Communication Theory Committee of the IEEE Communication Technology Group for publication without oral presentation. This work was supported in part by the National Science Foundation under Grant GK-24879 and in part by the Joint Services Electronics Program under Contract DAAB-07-67-C-0199. Manuscript received June 1, 1971.

The author is with the Coordinated Science Laboratory, University of Illinois, Urbana, Ill. 61801.

degree $n - 1$. All code polynomials $v(x)$ are multiples of a single polynomial $g(x)$, called the generator polynomial of the code.

A burst error of length l may be represented by

$$x^l B(x) = x^l(1 + b_1x + \dots + b_{l-1}x^{l-1})$$

where l is the starting position of the burst and each b_i may be either 1 or 0.

It is well known that for a cyclic code to detect all bursts of length $\leq l$ it is necessary and sufficient for its generator polynomial to have degree $\geq l$ and that it be not divisible by x . The simplest polynomial that satisfies these criteria is

$$g(x) = x^l + 1.$$

The implementation of this code is extremely simple. It only requires an end-around feedback register of length l .

Any cyclic code designed this way for detecting burst errors also detects many other errors. It detects any error pattern that in its polynomial form is not divisible by $g(x)$. Hence, the inherent detection capability of the code is much greater than detecting the bursts alone. In addition one may ensure the detection of all odd errors (error patterns with an odd number of error bits) by simply including $1 + x$ as a factor of $g(x)$. The $(1 + x)$ term serves as the overall parity of the code.

B. Burst Correction

Codes for correcting a single burst have been the subject of extensive study. The most general and versatile class is the class of codes known as Fire codes. The Fire codes are generated by the generator polynomials of the form

$$g(x) = (x^e - 1)p(x)$$

where $p(x)$ is of degree m . This class of codes corrects all bursts of length $\leq b$ and detects all bursts of length $\leq d$ provided that 1) $e \geq d + b - 1$, 2) $m \geq b$, and 3) the period of $p(x)$, e , does not divide e .

The Fire code can be decoded with very simple circuitry. Only very simple decision logic is required in addition to a buffer for holding the received message and a syndrome register for holding the syndrome. Since these two registers are required even for the purposes of detection the additional logic for correction is negligible. The Fire codes are also very efficient in terms of redundancy. That is, nearly all syndromes are used for the purposes of burst correction. However, to achieve this one must have very long codes which may not be compatible with the single-burst assumption. A better way of using Fire codes is probably to use it for the correction of short bursts for improving throughput and to detect long bursts for holding up reliability.

C. High-Speed Burst Correction and Detection

The decoding speed of burst correcting codes is directly proportional to its length. For long codes this could result in excessive delay. It has been discovered recently

that a modified Fire code could be decoded at a much higher speed. The new decoding algorithm requires only minimal additional hardware and takes advantage of arithmetic operations. Since many data communication links are connected with computers such a scheme could be extremely practical.

To illustrate the concept let us consider the code generated by

$$\begin{aligned} g_1(x) &= (x^{11} + 1)(x^6 + x + 1) \\ &= x^{17} + x^{12} + x^{11} + x^6 + x + 1 \end{aligned}$$

This code is of length $n = 693$ and can correct all bursts of lengths up to 6. The decoding time for this code will be 693 cycles after the syndrome is calculated. Let us now consider an alternative code with the generator polynomial

$$g_2(x) = (x^{11} + 1)(x^3 + x + 1)(x^4 + x + 1).$$

It can be verified that this code will correct all bursts of length 3 or less and most of the bursts of length 6 or less, and has a code length of 1155 bits. It is therefore a close competitor of the code generated by $g_1(x)$. The important fact, however, is that this code can be decoded in 26 cycles with a few multiplications for location identification. The decoder for this code is shown in Fig. 1.

The decoding operation proceeds as follows. First, parity checking is done via three feedback shift registers corresponding to the three factors. If all three remainders are zero, the decoder will assume no error to be present. If some but not all remainders are zero, an error is detected but not corrected. If all three are nonzero, an error will be corrected provided the error is a burst of length ≤ 6 .

The error correction is carried out as follows. The burst pattern is present in the register representing $x^{11} + 1$. It is shifted cyclically until the burst is at the lowest position that is detected by the "test for zero" circuit. This count is equal to $11 - r_{11} \bmod 11$. Hence,

$$i \equiv r_{11} \bmod 11.$$

By feeding the burst pattern into the two other registers and counting, one can easily calculate r_7 and r_{15} as defined by

$$i \equiv r_7 \bmod 7$$

and

$$i \equiv r_{15} \bmod 15.$$

By the Chinese remainder theorem technique, the three residues uniquely determine i up to a multiple of $n = 1155$, hence giving the precise location of the error, while the burst pattern is present in the first register.

The Chinese remainder theorem suggests that we find three integers A_1 , A_2 , and A_3 such that

$$A_1(11) + A_2(7) + A_3(15) \equiv 1.$$

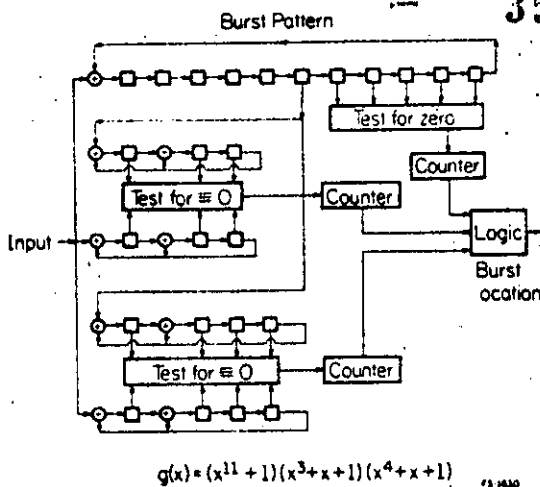


Fig. 1. High-speed decoder for burst correction.

The location of the burst is then given by

$$i = A_1(11)(r_{11}) + A_2(7)(r_7) + A_3(15)(r_{15}).$$

We note that the decoding would take a maximum of 26 cycles and three multiplications. A conventional Fire-code decoder for this code will take 1155 cycles.

As a further illustration, the code generated by $g(x) = (x^{17} + 1)(x^{10} + x^5 + x^2 + 1)(x^3 + x + 1)$ with a normal Fire-code decoder would take $37 \times (2^{10} - 1) = 19360731$ cycles. The code will correct all bursts of length ≤ 19 . The code generated by

$$g(x) = (x^{17} + 1)(x^{10} + x^3 + 1)(x^3 + x + 1)$$

using the high-speed decoder will decode in 1060 cycles and three multiplications. It corrects all bursts of length ≤ 9 . For bursts of length between 9 and 19, more than 99.6 percent are corrected; the rest are detected.

The general code can be described by the generator polynomial

$$g(x) = (x^r - 1) \prod_{i=1}^m p_i(x).$$

Various classes of codes can be constructed for each value of m .

Some of the codes for $m = 2$ are listed in Table I. Where s is the number of cycles required in decoding, all burst of length $\leq b_n$ are corrected, most of the bursts of length $\leq b$ are corrected. E represents the percentage of burst of length between b_n and b that are correctable with the high-speed decoding algorithm. All bursts of lengths $\leq b$ are detected.

A number of codes with $m = 3$ are listed in Table II. It is apparent that m increases the decoding speed also increases while E tends to fall off.

III. BCH CODES AND CORRECTION OF INDEPENDENT ERRORS

A. BCH Codes

To correct independent errors, the BCH codes are quite powerful and can be easily instrumented now with

TABLE I

SOME CODES FOR HIGH-SPEED BURST CORRECTION; $m = 2$

$g(x)$	n	s	b_n	b	E (percent)
$(x^{11}-1)(x^4+x+1)(x^3+x+1)$	1155	26	3	6	79
$(x^{13}-1)(x^4+x+1)(x^3+x+1)$	1365	28	3	7	79
$(x^{13}-1)(x^5+x^2+1)(x^3+x+1)$	2821	44	3	7	82
$(x^{15}-1)(x^5+x^2+1)(x^3+x+1)$	3255	46	3	8	82
$(x^{17}-1)(x^5+x^2+1)(x^4+x+1)$	7905	48	4	9	90
$(x^{19}-1)(x^6+x+1)(x^3+x^2+1)$	37107	82	5	10	95
$(x^{21}-1)(x^7+x^3+1)(x^3+x^2+1)$	82677	148	5	11	96

the invention of the Berlekamp iterative algorithm. The BCH codes are generated by polynomials of the form

$$g(x) = LCM\{m_1(x), m_2(x), \dots, m_{2t}(x)\}$$

where $m_i(x)$ is the minimum polynomial of α^i and α is a primitive root of $GF(2^m)$. The detail structures of BCH codes are well known and are discussed in all coding theory books. The essential property is that

$$g(\alpha^j) = 0, \quad j = 1, 2, 3, \dots, 2t$$

where t is the number of errors correctable. The length of BCH codes is usually $2^m - 1$ or a factor of that number. Error correction can be accomplished by solving the set of simultaneous nonlinear algebraic equations

$$S_j = \sum Y_i X_i^j, \quad j = 1, 2, 3, \dots, 2t$$

where $S_j = r(\alpha^j)$ is the j th power-symmetric function calculated from the received polynomial $r(x)$. The X_i are the location numbers. The Y_i are the error magnitudes and $Y_i = 1$ for all i for the binary case. The solution can be obtained through matrix techniques, but computationally they are not as efficient as the Berlekamp algorithm to be presented in the next section. Basically we define a location polynomial

$$\sigma(x) = x^t + \sigma_1 x^{t-1} + \dots + \sigma_t$$

and solve the set of linear equations

$$S_{2t} + \sigma_1 S_{2t-1} + \sigma_2 S_{2t-2} + \dots + \sigma_t S_t = 0$$

$$S_{2t-1} + \sigma_1 S_{2t-2} + \sigma_2 S_{2t-3} + \dots + \sigma_t S_{t-1} = 0$$

$$S_{t+1} + \sigma_1 S_t + \sigma_2 S_{t-1} + \dots + \sigma_t S_1 = 0$$

for $\sigma_1, \sigma_2, \dots, \sigma_t$, which is then used to find X_1, X_2, \dots, X_t . The Y_i generally are solved from another matrix equation involving S_j and X_i .

B. Berlekamp Iterative Algorithm—An Intuitive Discussion

In the formulation of the Berlekamp algorithm, we first define

TABLE II
SOME CODES FOR HIGH-SPEED BURST CORRECTION; $m = 3$

$g(x)$	n	e	b_0	b	E (percent)
$(x^{17}-1)(x^5+x^2+1)(x^3+x+1)(x^2+x+1)$	11067	48	2	9	49
$(x^{17}-1)(x^5+x^2+1)(x^4+x+1)(x^3+x+1)$	55335	48	3	9	75
$(x^{19}-1)(x^5+x^2+1)(x^3+x+1)(x^3+x+1)$	12369	50	2	10	49
$(x^{19}-1)(x^5+x^2+1)(x^4+x+1)(x^3+x+1)$	61845	50	3	10	75
$(x^{21}-1)(x^7+x^3+1)(x^5+x^2+1)(x^3+x+1)$	578739	148	3	11	81
$(x^{23}-1)(x^5+x^2+1)(x^4+x+1)(x^3+x+1)$	74865	54	3	12	75
$(x^{23}-1)(x^7+x^3+1)(x^4+x+1)(x^3+x+1)$	306705	150	3	12	78
$(x^{23}-1)(x^7+x^3+1)(x^5+x^2+1)(x^3+x+1)$	633857	150	3	12	81

$$\sigma(z) = 1 + \sigma_1 z + \dots + \sigma_t z^t = \prod_{i=1}^t (1 - zX_i)$$

$$S(z) = S_1 z + S_2 z^2 + \dots$$

$$\omega(z) = \omega_0 + \omega_1 z + \dots$$

and establish the equation

$$[1 + S(z)]\sigma(z) = \omega(z),$$

which is also used to define $\omega(z)$.

A close examination readily establishes the fact that

$$\begin{aligned} [1 + S(z)]\sigma(z) &= (1 + S_1 z + S_2 z^2 + S_3 z^3 + \dots)(1 + \sigma_1 z + \dots + \sigma_t z^t) \\ &= 1 + (S_1 + \sigma_1)z + (S_2 + \sigma_1 S_1 + \sigma_2)z^2 + \dots \\ &\quad + (S_t + \sigma_1 S_{t-1} + \sigma_2 S_{t-2} + \dots + \sigma_t)z^t \\ &\quad + (S_{t+1} + \sigma_1 S_t + \sigma_2 S_{t-1} + \dots + \sigma_t S_t)z^{t+1} \\ &\quad + \dots + (S_{2t} + \sigma_1 S_{2t-1} + \dots + \sigma_t S_t)z^{2t} + \dots \end{aligned}$$

The coefficients of z^{t+1}, z^{t+2}, \dots are therefore zero. It is implied that the degree of $\omega(z)$ is always less than or equal to the degree of $\sigma(z)$.

Let $\sigma_1', \sigma_2', \sigma_3', \dots, \sigma_{t-1}'$ be elementary symmetric functions with the variable X_i ($i = 1, 2, \dots, t, i \neq j$), then it follows immediately that

$$\sigma_1 = -(X_1 + X_2 + \dots + X_t) = \sigma_1' - X_j$$

$$\sigma_2 = \sigma_2' - X_j \sigma_1'$$

$$\sigma_3 = \sigma_3' - X_j \sigma_2'$$

$$\sigma_t = -X_j \sigma_{t-1}'$$

We then have

$$\begin{aligned} \omega(z) &= 1 + (S_1 + \sigma_1)z + (S_2 + \sigma_1 S_1 + \sigma_2)z^2 + \dots \\ &\quad + (S_t + \sigma_1 S_{t-1} + \dots + \sigma_t)z^t \\ &= \sigma(z) + S_1 z + (S_2 + \sigma_1 S_1)z^2 + \dots \\ &\quad + (S_t + \sigma_1 S_{t-1} + \dots + \sigma_t S_t)z^t \end{aligned}$$

Substituting z with X_j^{-1} we have

$$\begin{aligned} \omega(X_j^{-1}) &= S_1 X_j^{-1} + (S_2 + \sigma_1' S_1 - X_j S_1)X_j^{-2} \\ &\quad + (S_t + \sigma_1' S_2 - X_j S_2 + \sigma_2' S_1 - X_j \sigma_1' S_1)X_j^{-3} + \dots \\ &\quad + (S_t + \sigma_1' S_{t-1} - X_j S_{t-1} + \sigma_2' S_{t-2} - \sigma_1' X_j S_{t-2} \\ &\quad + \dots + X_j^{-t}). \end{aligned}$$

Due to successive cancellations it is reduced to

$$\begin{aligned} X_j^t \omega(X_j^{-1}) &= S_t + \sigma_1' S_{t-1} + \sigma_2' S_{t-2} + \dots + \sigma_{t-1}' S_1 \\ &= \sum Y_k X_k^t + \sigma_1' \sum Y_k X_k^{t-1} + \dots + \sigma_{t-1}' \sum Y_k X_k \\ &= \sum_{k=1}^t Y_k X_k \prod_{i \neq j} (X_k - X_i). \end{aligned}$$

Since the term that is nonzero is when $k = j$, the equation reduces to

$$X_j^{t-1} \omega(X_j^{-1}) = Y_j \prod_{i \neq j} (X_i - X_j)$$

or

$$Y_j = \frac{X_j^{t-1} \omega(X_j^{-1})}{\prod_{i \neq j} (X_i - X_j)} = \frac{\omega(X_j^{-1})}{\prod_{i \neq j} (1 - X_i X_j^{-1})}$$

This is a formula for direct calculation of Y_j once the X_i are known.

To solve the equation

$$[1 + S(z)]\sigma(z) = \omega(z) \text{ mod } z^{2t+1} \tag{1}$$

Berlekamp suggested that we may use an iterative procedure and solve the equation

$$[1 + S(z)]\sigma^{(n)}(z) = \omega^{(n)}(z) \text{ mod } z^{n+1} \tag{2}$$

for $n = 0, 1, 2, \dots, 2t$.

For $n = 0$, it is clear that

$$\sigma^{(0)}(z) = 1, \quad \omega^{(0)}(z) = 1$$

is a solution for $n = 0$. If $S_1 = S_2 = \dots = S_{j-1} = 0, S_j \neq 0$, then for $n < j$,

$$\sigma^{(n)} = 1, \quad \omega^{(n)} = 1$$

is a solution. For $n = j$, there are at least two possible solutions

$$\sigma^{(n)} = 1 - S_j z^j, \quad \omega^{(n)} = 1 \tag{3}$$

and

$$\sigma^{(n)} = 1, \quad \omega^{(n)} = 1 + S_j z^j.$$

In general, the solution in each step is not unique. Our approach here is to choose a solution that will minimize a certain quantity

$$D(n) = \max [\deg \sigma^{(n)}, \deg \omega^{(n)}]. \tag{3}$$

As will be proved later, given a solution $\sigma^{(n)*}, \omega^{(n)*}$ such that $D(n)^*$ is a minimum, the algorithm will provide a solution for the next step, i.e., $\sigma^{(n+1)*}, \omega^{(n+1)*}$, such that $D(n+1)^*$ is also a minimum.

Let us now consider a solution $\sigma^{(n)}, \omega^{(n)}$. In general, this solution will not satisfy the equation for the $(n+1)$ th step, that is, when the modulus is z^{n+2} . When this is the case, a quantity $\Delta(n)$ known as the n th next discrepancy is introduced and we write

$$(1 + S)\sigma^{(n)} \equiv \omega^{(n)} + \Delta(n)z^{n+1} \pmod{z^{n+2}}. \tag{4}$$

As (2) and (4) are linear in nature, it is observed that if $\sigma_a^{(n)}, \omega_a^{(n)}$ and $\sigma_b^{(n)}, \omega_b^{(n)}$ are both solutions of (2), then for α, β in $\text{GF}(q^m)$, $\alpha\sigma_a^{(n)} + \beta\sigma_b^{(n)}$, $\alpha\omega_a^{(n)} + \beta\omega_b^{(n)}$ is also a solution. Furthermore, if the n th next discrepancies of $\sigma_a^{(n)}, \omega_a^{(n)}$ and $\sigma_b^{(n)}, \omega_b^{(n)}$ are, respectively, $\Delta_a(n), \Delta_b(n)$, then the n th next discrepancy of $\alpha\sigma_a^{(n)} + \beta\sigma_b^{(n)}$, $\alpha\omega_a^{(n)} + \beta\omega_b^{(n)}$ is simply $\alpha\Delta_a(n) + \beta\Delta_b(n)$. This observation will be very useful in the proof of Lemma 1. We remark that it is possible and convenient to consider only those σ such that $\sigma(0) = 1$.

Lemma 1: Let

$$(1 + S)\sigma^{(n)} \equiv \omega^{(n)} \pmod{z^{n+1}}$$

$$(1 + S)\sigma^{(n)} \equiv \omega^{(n)} + \Delta(n)z^{n+1} \pmod{z^{n+2}}$$

where $\Delta(n) \neq 0$. If for some $n' < n$

$$(1 + S)\sigma^{(n')} \equiv \omega^{(n')} \pmod{z^{n'+1}} \tag{5}$$

$$(1 + S)\sigma^{(n')} \equiv \omega^{(n')} + \Delta(n')z^{n'+1} \pmod{z^{n'+2}} \tag{6}$$

where $\Delta(n') \neq 0$, then

$$\sigma^{(n+1)} = \sigma^{(n)} - \Delta(n) \Delta(n')^{-1} z^{n-n'} \sigma^{(n')} \tag{7}$$

$$\omega^{(n+1)} = \omega^{(n)} - \Delta(n) \Delta(n')^{-1} z^{n-n'} \omega^{(n')} \tag{8}$$

satisfies

$$(1 + S)\sigma^{(n+1)} \equiv \omega^{(n+1)} \pmod{z^{n+2}}. \tag{9}$$

Proof: Multiply (5) and (6) by $z^{n-n'}$, we have

$$(1 + S)\sigma^{(n')} z^{n-n'} \equiv \omega^{(n')} z^{n-n'} \pmod{z^{n+1}}$$

$$(1 + S)\sigma^{(n')} z^{n-n'} \equiv \omega^{(n')} z^{n-n'} + \Delta(n') z^{n+1} \pmod{z^{n+2}}.$$

Consider now the pair

$$\sigma_A^{(n+1)} = \sigma^{(n)} + \beta \sigma^{(n')} z^{n-n'}, \quad \omega_A^{(n+1)} = \omega^{(n)} + \beta \omega^{(n')} z^{n-n'}$$

By the linear property

$$(1 + S)\sigma_A^{(n+1)} \equiv \omega_A^{(n+1)} \pmod{z^{n+1}}$$

$$(1 + S)\sigma_A^{(n+1)} \equiv \omega_A^{(n+1)} + (\Delta(n) + \beta\Delta(n'))z^{n+1} \pmod{z^{n+2}}.$$

Let $\beta = -\Delta(n) \Delta(n')^{-1}$, we have

$$\sigma^{(n+1)} = \sigma_A^{(n+1)} \Big|_{\beta}$$

$$= -\Delta(n) \Delta(n')^{-1} = \sigma^{(n)} - \Delta(n) \Delta(n')^{-1} z^{n-n'} \sigma^{(n')}$$

$$\omega^{(n+1)} = \omega_A^{(n+1)} \Big|_{\beta}$$

$$= -\Delta(n) \Delta(n')^{-1} = \omega^{(n)} - \Delta(n) \Delta(n')^{-1} z^{n-n'} \omega^{(n')}$$

and

$$(1 + S)\sigma^{(n+1)} \equiv \omega^{(n+1)} \pmod{z^{n+2}}.$$

Q.E.D.

We note that Lemma 1 can also be very easily proved by a direct substitution as follows:

$$(1 + S)\sigma^{(n+1)}$$

$$= (1 + S)(\sigma^{(n)} - \Delta(n) \Delta(n')^{-1} z^{n-n'} \sigma^{(n')})$$

$$= (1 + S)\sigma^{(n)} - \Delta(n) \Delta(n')^{-1} z^{n-n'} (1 + S)\sigma^{(n')}$$

$$\equiv \omega^{(n)} + \Delta(n)z^{n+1} - \Delta(n) \Delta(n')^{-1} z^{n-n'} \omega^{(n')}$$

$$- \Delta(n) \Delta(n')^{-1} z^{n-n'} \Delta(n') z^{n'+1}$$

$$= \omega^{(n)} - \Delta(n) \Delta(n')^{-1} z^{n-n'} \omega^{(n')}$$

$$= \omega^{(n+1)} \pmod{z^{n+2}}.$$

However, the proof given has provided more insight by showing how the expressions for $\sigma^{(n+1)}, \omega^{(n+1)}$ are constructed and hence that proof is more illustrative.

Lemma 2: Let $\sigma^{(n)}, \omega^{(n)}$ be given as in Lemma 1. If $\sigma^{(n+1)}, \omega^{(n+1)}$ are given, such that

$$(1 + S)\sigma^{(n+1)} \equiv \omega^{(n+1)} \pmod{z^{n+2}}$$

then there exist $\sigma^{(n')}, \omega^{(n')}$ with $n' < n$ satisfying

$$(1 + S)\sigma^{(n')} \equiv \omega^{(n')} \pmod{z^{n'+1}}$$

$$(1 + S)\sigma^{(n')} \equiv \omega^{(n')} + \Delta(n')z^{n'+1} \pmod{z^{n'+2}}$$

with $\Delta(n') \neq 0$, such that

$$\sigma^{(n+1)} = \sigma^{(n)} - \Delta(n) \Delta(n')^{-1} z^{n-n'} \sigma^{(n')}$$

$$\omega^{(n+1)} = \omega^{(n)} - \Delta(n) \Delta(n')^{-1} z^{n-n'} \omega^{(n')}.$$

Proof: Since

$$(1 + S)\sigma^{(n+1)} \equiv \omega^{(n+1)} \pmod{z^{n+2}}$$

implies

$$(1 + S)\sigma^{(n+1)} \equiv \omega^{(n+1)} \pmod{z^{n+1}}$$

then by the linear property, we have

$$(1 + S)(\sigma^{(n+1)} - \sigma^{(n)}) \equiv \omega^{(n+1)} - \omega^{(n)} \pmod{z^{n+1}} \tag{10}$$

$$(1 + S)(\sigma^{(n+1)} - \sigma^{(n)}) \equiv \omega^{(n+1)} - \omega^{(n)} - \Delta(n)z^{n+1} \pmod{z^{n+2}}. \tag{11}$$

As the constant term of both $\sigma^{(n+1)}$ and $\sigma^{(n)}$ are 1, $\sigma^{(n+1)} - \sigma^{(n)}$ is divisible by a power of z . Let αz^x be the nonzero term of lowest order of $\sigma^{(n+1)} - \sigma^{(n)}$. We may write

$$\sigma^{(n+1)} - \sigma^{(n)} = \alpha z^x \frac{\sigma^{(n+1)} - \sigma^{(n)}}{\alpha z^x}$$

Then $[\sigma^{(n+1)} - \sigma^{(n)}]/\alpha z^x$ is a polynomial with a constant term equal to 1. As

$$(1 + S)(\sigma^{(n+1)} - \sigma^{(n)}) \equiv \omega^{(n+1)} - \omega^{(n)} \pmod{z^{x+1}}$$

it then follows that $\omega^{(n+1)} - \omega^{(n)}$ is divisible by αz^x and $[\omega^{(n+1)} - \omega^{(n)}]/\alpha z^x$ is also a polynomial, with a constant term having the value of one. Consequently, (11) can be written as

$$(1 + S) \frac{\sigma^{(n+1)} - \sigma^{(n)}}{\alpha z^x} \equiv \frac{\omega^{(n+1)} - \omega^{(n)}}{\alpha z^x} - \frac{\Delta(n)}{\alpha} z^{n-x+1} \pmod{z^{n-x+2}}$$

Define

$$n'' = n - x, \quad \Delta(n'') = -\frac{\Delta(n)}{\alpha}$$

$$\sigma^{(n'')} = \frac{\sigma^{(n+1)} - \sigma^{(n)}}{\alpha z^x}, \quad \omega^{(n'')} = \frac{\omega^{(n+1)} - \omega^{(n)}}{\alpha z^x}$$

We have

$$(1 + S)\sigma^{(n'')} \equiv \omega^{(n'')} \pmod{z^{n''+1}}$$

$$(1 + S)\sigma^{(n'')} \equiv \omega^{(n'')} + \Delta(n'')z^{n''+1} \pmod{z^{n''+2}}$$

and

$$\sigma^{(n+1)} = \sigma^{(n)} - \Delta(n) \Delta(n'')^{-1} z^{n-n''} \sigma^{(n'')}$$

$$\omega^{(n+1)} = \omega^{(n)} - \Delta(n) \Delta(n'')^{-1} z^{n-n''} \omega^{(n'')}$$

Q.E.D.

Lemma 3: Let $D(n) = \max \{ \deg \sigma^{(n)}, \deg \omega^{(n)} \}$, for all $\sigma^{(n)}, \omega^{(n)}$ satisfying (2) and (4). Let $\sigma^{(n)*}, \omega^{(n)*}$ be a solution such that $D(n)^* = \max \{ \deg \sigma^{(n)*}, \deg \omega^{(n)*} \} = \min \{ D(n) \}$. Let $D(n') = \max \{ \deg \sigma^{(n')}, \deg \omega^{(n')} \}$ for any pair $\sigma^{(n')}, \omega^{(n')}$ satisfying (5) and (6). Furthermore, let

$$\sigma^{(n+1)} = \sigma^{(n)*} - \Delta(n)^* \Delta(n')^{-1} z^{n-n'} \sigma^{(n')} \tag{12}$$

$$\omega^{(n+1)} = \omega^{(n)*} - \Delta(n)^* \Delta(n')^{-1} z^{n-n'} \omega^{(n')} \tag{13}$$

Then

$$D(n+1) = \max \{ D(n)^*, n - n' + D(n') \}. \tag{14}$$

Proof: As

$$(1 + S)\sigma^{(n+1)} \equiv \omega^{(n+1)} \pmod{z^{n+2}}$$

implies

$$(1 + S)\sigma^{(n+1)} \equiv \omega^{(n+1)} \pmod{z^{n+1}}$$

we have

$$D(n+1) \geq D(n)^* \tag{15}$$

Case 1:

$$\deg \sigma^{(n+1)} < \max \{ \deg \sigma^{(n)*}, n - n' + \deg \sigma^{(n')} \}$$

$$\deg \omega^{(n+1)} < \max \{ \deg \omega^{(n)*}, n - n' + \deg \omega^{(n')} \}$$

The first condition is possible only if the leading terms of $\sigma^{(n)*}$ and $\Delta(n)^* \Delta(n')^{-1} z^{n-n'} \sigma^{(n')}$ cancel each other. This will imply $\deg \sigma^{(n+1)} < \deg \sigma^{(n)*}$. Similarly, the second condition implies $\deg \omega^{(n+1)} < \deg \omega^{(n)*}$. Therefore, $D(n)^* > D(n+1)$, which contradicts (15). Consequently, Case 1 never occurs when $\sigma^{(n+1)}, \omega^{(n+1)}$ are generated according to Lemma 3.

Case 2:

$$\deg \sigma^{(n+1)} = \max \{ \deg \sigma^{(n)*}, n - n' + \deg \sigma^{(n')} \}$$

$$\deg \omega^{(n+1)} = \max \{ \deg \omega^{(n)*}, n - n' + \deg \omega^{(n')} \}$$

In this case:

$$\begin{aligned} D(n+1) &= \max \{ \deg \sigma^{(n+1)}, \deg \omega^{(n+1)} \} \\ &= \max \{ \deg \sigma^{(n)*}, n - n' + \deg \sigma^{(n')}, \\ &\quad \deg \omega^{(n)*}, n - n' + \deg \omega^{(n')} \} \\ &= \max \{ D(n)^*, n - n' + D(n') \}. \end{aligned}$$

Case 3:

$$\deg \sigma^{(n+1)} < \max \{ \deg \sigma^{(n)*}, n - n' + \deg \sigma^{(n')} \}$$

$$\deg \omega^{(n+1)} = \max \{ \deg \omega^{(n)*}, n - n' + \deg \omega^{(n')} \}$$

The first condition implies

$$\deg \sigma^{(n+1)} = \deg \sigma^{(n)*} \tag{16}$$

$$\deg \sigma^{(n)*} = n - n' + \deg \sigma^{(n')} \tag{17}$$

By (15) and (16)

$$\begin{aligned} D(n+1) &= \deg \omega^{(n+1)} \\ &= \max \{ \deg \omega^{(n)*}, n - n' + \deg \omega^{(n')} \}. \end{aligned} \tag{18}$$

By (17) and (18) and the definition of $D(n)^*$

$$\begin{aligned} D(n+1) &= \max \{ \deg \omega^{(n)*}, n - n' + \deg \omega^{(n')}, \\ &\quad \deg \sigma^{(n)*}, n - n' + \deg \sigma^{(n')} \} \\ &= \max \{ D(n)^*, n - n' + D(n') \}. \end{aligned}$$

Case 4:

$$\deg \sigma^{(n+1)} = \max \{ \deg \sigma^{(n)*}, n - n' + \deg \sigma^{(n')} \}$$

$$\deg \omega^{(n+1)} < \max \{ \deg \omega^{(n)*}, n - n' + \deg \omega^{(n')} \}$$

This case can be proved in a manner paralleling the proof of Case 3 by interchanging the symbols σ and ω .

Q.E.D.

Now we are ready to prove a theorem.

Theorem 1: Let $\sigma^{(n+1)}, \omega^{(n+1)}$ be defined as in Lemma 3. If $n' \leq n$ is so selected that $n' = D(n')$ is the largest

possible, then $\sigma^{(n+1)}, \omega^{(n+1)}$ is a solution of (9) with minimum $D(n+1)$.

Proof: By Lemma 1, $\sigma^{(n+1)}, \omega^{(n+1)}$ clearly satisfy (9). Suppose there exists another solution $\sigma_A^{(n+1)}, \omega_A^{(n+1)}$ such that $D_A(n+1) < D(n+1)$, then by Lemma 2, from some $n'' < n$

$$\sigma_A^{(n+1)} = \sigma^{(n)'} - \Delta(n) \Delta(n'')^{-1} z^{n-n''} \sigma^{(n'')'}$$

$$\omega_A^{(n+1)} = \omega^{(n)'} - \Delta(n) \Delta(n'')^{-1} z^{n-n''} \omega^{(n'')}'$$

By Lemma 3

$$D(n+1) = \max [D(n)', n - n' + D(n)']$$

$$D_A(n+1) = \max [D(n)', n - n'' + D(n'')']$$

If $D_A(n+1) < D(n+1)$, then

$$n - n'' + D(n'') < n - n' + D(n')$$

or

$$n'' - D(n'') > n' - D(n')$$

contradicting our assumption. Hence $D(n+1)$ is a minimum. Q.E.D.

Based on the preceding theorem and the discussion in the beginning of this section, the following modified version of the Berlekamp iterative algorithm is proposed for the solution of the key equation.

Algorithm: (The asterisk symbol is omitted here since all quantities are starred.)

1) Let j be the smallest integer such that $S_j \neq 0$. The initial parameters are

$$n' = j - 1, \quad n = j$$

$$\sigma^{(n')} = 1, \quad \omega^{(n')} = 1, \quad \Delta(n') = S_j, \quad D(n') = 0$$

$$\sigma^{(n)} = 1 - S_j z^j, \quad \omega^{(n)} = 1.$$

2) For $N > j$, calculate iteratively

$$\Delta(n) = \sum_{i=0}^{\deg \sigma^{(n)}} \sigma_i^{(n)} S_{n+1-i}$$

a) If $\Delta(n) = 0$, then set

$$\sigma^{(n+1)} = \sigma^{(n)}$$

$$\omega^{(n+1)} = \omega^{(n)}$$

$$D(n+1) = D(n)$$

and proceed with the iteration.

b) If $\Delta(n) \neq 0$, then set

$$\sigma^{(n+1)} = \sigma^{(n)} - \Delta(n) \Delta(n')^{-1} z^{-1} z^{n-n'} \sigma^{(n')'}$$

$$\omega^{(n+1)} = \omega^{(n)} - \Delta(n) \Delta(n')^{-1} z^{-1} z^{n-n'} \omega^{(n')}'$$

$$D(n) = \max [D(n), n - n' + D(n')].$$

If $n - D(n) > n' - D(n')$, replace all quantities relating n' with corresponding quantities relating to n and proceed with the iteration.

Given the $2t$ successive syndrome terms S_1, S_2, \dots, S_{2t} ,

S_{2t} , the algorithm will terminate with $\sigma = \sigma^{(2t)}$ and $\omega = \omega^{(2t)}$. If there are no more than t errors in the received vector, the result will be $\deg \sigma^{(2t)} = D(2t) \leq t$. All $D(t)$ roots of $\sigma^{(2t)}$ are in $\text{GF}(q^m)$ and all error magnitudes given by $\omega^{(2t)}$ are in $\text{GF}(q)$. The decoding is then complete.

IV. OTHER CODING TECHNIQUES OF PRACTICAL VALUE

A. Reed-Solomon Codes

The Reed-Solomon codes are a special case of BCH codes but they are quite useful in practical applications hence deserve special attention. The Reed-Solomon codes are generated by polynomials of the form

$$g(x) = (x - \alpha^0)(x - \alpha^1) \cdots (x - \alpha^{2t-1})$$

for correcting t symbols. Usually α would be a primitive root of $\text{GF}(2^m)$ and the code length would then be $2^m - 1$ symbols of $m(2^m - 1)$ bits. The code in fact correct inphase bursts of length in each. This correction capability seem to match channel statistics very well.

Of particular significance is for the case $t = 1$ in which case the code corrects one inphase burst of length m , but decoding now becomes very very simple. The equations are

$$S_0 = Y_1$$

$$S_1 = Y_1 X_1$$

hence the solutions are easily computed as

$$Y_1 = S_0$$

$$X_1 = S_1/S_0.$$

This simple code can find applications in many systems.

B. Product Codes

The product codes are two dimensional codes where the rows are codewords of a (n_1, k_1) code generated by $g_1(x)$ with the columns as codewords of a (n_2, k_2) code generated by $g_2(x)$.

The performance of the product code can be derived easily from the respective components codes. If the minimum distance for the code generated by $g_1(x)$ is d_1 and the minimum distance for the code generated by $g_2(x)$ be d_2 , it can be shown easily that the minimum distance of the product code is $d = d_1 d_2$. Many error patterns can be corrected easily with cascade decoding of a product code. Either the rows or the columns can be decoded first. The decoders are a lot simpler than otherwise needed.

Product codes can also be used for burst correction. Suppose the burst correcting capability of $g_1(x)$ and $g_2(x)$ are respectively b_1 and b_2 then the product code can correct all burst of length $b = \text{Max}(b_1 n_2, b_2 n_1)$.

C. Majority Decoding

Many of the cyclic codes are decodable with majority decoding. For instance the $(15, 7)$ code generated by

$$g(x) = 1 + x^1 + x^6 + x^7 + x^8$$

is majority decodable in one step. This can be seen by seeing that

328

$$S = cH^T = [c_0 c_1 \cdots c_{14}] \begin{bmatrix} 1 & 0 & 0 & 0 & 0 & 0 & 0 & 0 \\ 0 & 1 & 0 & 0 & 0 & 0 & 0 & 0 \\ 0 & 0 & 1 & 0 & 0 & 0 & 0 & 0 \\ 0 & 0 & 0 & 1 & 0 & 0 & 0 & 0 \\ 0 & 0 & 0 & 0 & 1 & 0 & 0 & 0 \\ 0 & 0 & 0 & 0 & 0 & 1 & 0 & 0 \\ 0 & 0 & 0 & 0 & 0 & 0 & 1 & 0 \\ 0 & 0 & 0 & 0 & 0 & 0 & 0 & 1 \\ 1 & 0 & 0 & 0 & 1 & 0 & 1 & 1 \\ 1 & 1 & 0 & 0 & 1 & 1 & 1 & 0 \\ 0 & 1 & 1 & 0 & 0 & 1 & 1 & 1 \\ 1 & 0 & 1 & 1 & 1 & 0 & 0 & 0 \\ 0 & 1 & 0 & 1 & 1 & 1 & 0 & 0 \\ 0 & 0 & 1 & 0 & 1 & 1 & 1 & 0 \\ 0 & 0 & 0 & 1 & 0 & 1 & 1 & 1 \end{bmatrix}$$

$$= [S_0 S_1 S_2 \cdots S_7].$$

Therefore,

$$S_0 = c_0 + c_8 + c_9 + c_{11}$$

$$S_1 = c_1 + c_9 + c_{10} + c_{12}$$

$$S_2 = c_2 + c_{10} + c_{11} + c_{13}$$

$$S_3 = c_3 + c_{11} + c_{12} + c_{14}$$

$$S_4 = c_4 + c_8 + c_9 + c_{11} + c_{12} + c_{13}$$

$$S_5 = c_5 + c_9 + c_{10} + c_{12} + c_{13} + c_{14}$$

$$S_6 = c_6 + c_8 + c_9 + c_{10} + c_{13} + c_{14}$$

$$S_7 = c_7 + c_8 + c_{10} + c_{14}.$$

It then follows that

$$S_3 = c_3 + c_{11} + c_{12} + c_{14}$$

$$S_1 + S_5 = c_1 + c_5 + c_{13} + c_{14}$$

$$S_0 + S_2 + S_6 = c_0 + c_2 + c_6 + c_{14}$$

$$S_7 = c_7 + c_8 + c_{10} + c_{14}.$$

In the above set of equations, it is seen that c_{14} appears in every equation but other variables appear at most once. If c_{14} is 1, then a majority of the equations would end up in one. If c_{14} is 0, then at most two equations could end up in zero. Thus, assuming no more than two errors occurring, a good decision would be $c_{14} = 1$ when and only when a clear majority of the equations vote

for 1. For cyclic codes, this also means automatically a way of deciding on other bits.

Majority decoders are very simple and many codes are known which are majority decodable, although some codes require multilevel decision.

V. CONCLUSION

For channels with low error rate, error detection and retransmission proves to be a practical way of improving reliability. When error rate increases, the retransmission scheme may result in low throughput as more and more blocks have to be retransmitted. In those circumstances, it may be practical to consider hybrid schemes which correct a few errors but reserve the use of retransmission as a backup. This hybrid scheme may be more efficient than the pure retransmission scheme and yet more reliable than a pure forward error correction scheme. In this paper, a number of simple error correction schemes are reviewed for possible use in such a hybrid framework.

REFERENCES

- [1] E. R. Berlekamp, *Algebraic Coding Theory*. New York: McGraw-Hill, 1968.
- [2] S. Lin, *An Introduction to Error-Correcting Codes*. Princeton, N. J.: Prentice-Hall, 1971.
- [3] R. W. Lucky, J. Salz, and E. J. Weldon, Jr., *Principles of Data Communication*. New York: McGraw-Hill, 1968.
- [4] W. W. Peterson and E. J. Weldon, Jr., *Error-Correcting Codes*. Cambridge, Mass.: M.I.T. Press, 1971.
- [5] N. M. Abramson, "A class of systematic codes for non-independent errors," *IRE Trans. Inform. Theory*, vol. IT-5, Dec. 1959, pp. 150-157.
- [6] N. M. Abramson and B. Elspas, "Double-error-correcting coders and decoders for non-independent binary errors," presented at the 1959 UNESCO Inform. Processing Conf., Paris, France.
- [7] D. T. Brown and W. W. Peterson, "Cyclic codes for error detection," *Proc. IRE*, vol. 49, Jan. 1961, pp. 228-235.
- [8] R. T. Chien, "Burst-correcting codes with high-speed decoding," *IEEE Trans. Inform. Theory*, vol. IT-15, Jan. 1969, pp. 109-113.
- [9] B. Elspas and R. A. Short, "A note on optimum burst-error-correcting codes," *IRE Trans. Inform. Theory*, vol. IT-8, Jan. 1962, pp. 39-42.
- [10] P. Fire, "A class of multiple-error-correcting binary codes for non-independent errors," Sylvania Electron. Defense Lab., Reconnaissance Syst. Div., Mountain View, Calif., Sylvania Rep. RSL-E-2, Mar. 1959.
- [11] E. Gorog, "Some new classes of cyclic codes used for burst error correction," *IBM J. Res. Dev.*, vol. 7, 1963, pp. 102-111.
- [12] T. Kasami, "Cyclic codes for burst-error-correction," *J. Inst. Electron. Commun. Eng. Jap.*, vol. 45, Jan. 1962, pp. 9-16.
- [13] T. Kasami, "Optimum shortened cyclic codes for burst-error-correction," *IEEE Trans. Inform. Theory*, vol. IT-9, Apr. 1963, pp. 105-109.
- [14] J. J. Stone, "Multiple burst error correction," *Inform. Contr.*, vol. 4, Dec. 1961, pp. 324-331.
- [15] S. Y. Tong, "Burst trapping techniques for a compound channel," Bell Telephone Lab., Tech. Memo., 1968.
- [16] N. Abramson, "Cascade decoding of cyclic product codes," *IEEE Trans. Commun. Technol.*, vol. COM-16, June 1968, pp. 398-402.
- [17] L. Bahl and R. T. Chien, "A class of multiple-burst-error-correcting codes," presented at the 1969 IEEE Int. Symp. on Information Theory, Ellenville, N. Y.
- [18] E. R. Berlekamp, "Nonbinary BCH decoding," presented at the 1967 IEEE Int. Symp. on Information Theory, San Remo, Italy.
- [19] R. C. Bose and D. K. Ray-Chaudhuri, "On a class of error correcting binary group codes," *Inform. Contr.*, vol. 3, Mar. 1960, pp. 68-79.
- [20] H. O. Burton and E. J. Weldon, Jr., "Cyclic product codes," *IEEE Trans. Inform. Theory*, vol. IT-11, July 1965, pp. 433-439.

Una de las principales desventajas de los sistemas por satélite es el largo retraso introducido por la trayectoria de transmisión (270 milisegundos en un sentido). El efecto de este retraso puede minimizarse usando "protocolos" de transmisión.

Los protocolos empleados más comúnmente son:

- ALOHA
- S-ALOHA (slotted-ALOHA)
- Reservación implícita
- Reservación explícita
- Reservación ALOHA
- R-TDMA
- CFMA (Conflict-Free Multi-access)
- PODA (Priority-Oriented Demand Assignment)

ALOHA

El protocolo ALOHA en su versión más primitiva tuvo su origen en la Universidad de Hawaii; fué creado para interconectar terminales y computadoras vía satélite, conjuntamente con enlaces terrestres de radio.

En este protocolo, cada una de las estaciones terrenas transmite sus paquetes de datos siempre que tengan información que enviar, sin indagar si alguna otra estación de la red está transmitiendo en ese instante ó no. Nótese que todas las estaciones operan "simultáneamente" en TDMA. Debido a que no existe ninguna coordinación de asignación de tiempos para cada una de las estaciones terrenas, puede suceder que los paquetes

...2

357

de varias estaciones lleguen al mismo tiempo al satélite y "choquen" (paquet collision); cuando esto sucede, la información de todos los paquetes que chocan ó se traslapan se pierde. Por consiguiente, es necesario retransmitirlos.

Como el canal de comunicación del satélite empleado con el protocolo ALOHA opera en modo de "difusión", la estación transmisora cuyo paquete se perdió tiene la capacidad de detectar la colisión, e inmediatamente se prepara para retransmitir el paquete.

La eficiencia en el uso de la capacidad del canal es de 18%.

S-ALOHA

La eficiencia en el uso de la capacidad del canal puede mejorarse usando el protocolo S-ALOHA. Suponiendo que todos los paquetes de todas las estaciones son del mismo tamaño (ó sea que se requieren tiempos iguales para transmitirlos), entonces el canal de comunicación disponible en el satélite se ranura en segmentos cuya duración es exactamente igual al tiempo de transmisión de un solo paquete. Todas las estaciones terrenas se sincronizan de tal forma que sólo inicien la transmisión de paquetes al principio de una ranura. Este procedimiento evita el traslape parcial de paquetes, pero todavía puede haber traslape total; sin embargo, la eficiencia aumenta a 36% (ó sea el doble de la eficiencia del protocolo ALOHA), por supuesto a cambio de un control más complejo de las estaciones terrenas.

Uno de los más graves riesgos de los sistemas de acceso aleatorio ALOHA y S-ALOHA es que pueden volverse inestables si no se cuenta con un mecanismo de control eficiente para prevenir una "reacción en cadena" de "choques", retrasos, y colas enor-

mes de información "nueva" e información que debe retransmitirse.

Reservación implícita

En reservación implícita se usa el concepto de tener varios marcos dentro de un canal S-ALOHA. Cada marco puede subdividirse en una ó varias ranuras. El conjunto de todas las ranuras obtenidas de esta manera se subclasifica en dos grandes grupos: uno de ranuras reservadas y otro de ranuras que pueden ser accesadas usando el protocolo común de contención S-ALOHA. El grupo de ranuras reservadas se pone a disposición de las estaciones terrenas con altas tasas de tráfico, las cuales pueden acceder una ó varias de las ranuras de reservación en cada marco.

El principal problema de la reservación implícita es que se van asignando ranuras de reservación de acuerdo a la frecuencia del uso que tenga cada estación. Es decir, siempre que una estación (estación A) transmite con éxito dentro de una ranura, todas las demás estaciones asignan internamente esa ranura en marcos subsecuentes para el uso exclusivo de la estación A, hasta que ya no tenga paquetes que transmitir. Esta "captura" de la ó las ranuras puede continuar por tiempo indefinido y todas las demás estaciones deben conformarse con las ranuras del grupo de contención.

Reservación explícita

En el protocolo con reservación explícita, como su nombre lo indica, cada estación debe enviar un mensaje a todas las demás sobre qué ranuras disponibles de reservación y de qué marcos de sea utilizar para transmitir sus paquetes. Esto requiere de

una buena sincronización entre todas las estaciones para reducir ó evitar choques. Las solicitudes de reservación generalmente se envían en ranuras distintas a las de las empleadas para transmitir los paquetes de datos, y ésto reduce el ancho de banda aprovechable.

Reservación ALOHA

En este tipo de protocolo, el canal se subdivide en un número N de ranuras para transmisión de datos. Todas las estaciones tienen derecho a reservar, por cada solicitud, de una a ocho de las ranuras. Una vez registrada la solicitud de la estación A por todas las demás estaciones, se coloca en una "cola" de espera. Si la estación A tiene muchos paquetes que transmitir, puede hacer otra ó varias solicitudes más de una a ocho ranuras c/u, mismas que serán puestas en la cola de espera. Las reservaciones se hacen por contención usando ALOHA tradicional. Para ésto, después de M ranuras de transmisión de datos se ocupa la ranura $M+1$, subdividida en V ranuras pequeñas, para "solicitar reservaciones" (ver Figura 1).

Reservación TDMA (R-TDMA)

Este protocolo emplea la técnica de asignación fija para hacer las reservaciones, es decir, cada estación tiene su propia ranura para solicitar espacio dentro del canal de comunicación, a diferencia del caso anterior donde se hace por contención.

Con referencia a la figura 2, el canal de comunicación se divide en varios marcos de enrutamiento. Cada marco de enrutamiento se divide en varios marcos de reservación. Un marco de reservación consiste de un grupo de pequeñas ranuras de reser-

vación y de un número de ranuras para la transmisión de datos. El número de ranuras de reservación es igual al número de estaciones terrenas y cada una tiene su propia ranura con asignación fija. Además, cada estación terrena tiene asignada una ranura fija en cada marco de datos (las ranuras para transmisión de datos se agrupan en marcos de datos).

Cuando una estación no tiene información que enviar, envía un "cero" en su ranura de reservación, y automáticamente su ranura para la transmisión de datos queda disponible para las estaciones con mucha información por transmitir. (El reparto provisional de las nuevas ranuras se hace en forma secuencial).

Acceso múltiple sin conflicto, CFMA ó Conflict-Free Multi-access

Con este protocolo se elimina todo conflicto en el acceso múltiple (cero "choques").

El canal de comunicación se divide en marcos, y cada marco se subdivide de acuerdo a la figura 3. Como puede observarse, el marco contiene un vector R, un vector A y un vector I. El vector R se emplea para solicitar reservaciones futuras y queda dividido en un número determinado de ranuras de reservación, igual al número de estaciones terrenas en la red. Cada estación tiene asignada una ranura fija de reservación en el marco R, por lo cual no hay competencia ó contención por una ranura de reservación.

El vector A se divide en un número de mini-ranuras que se utilizan para enviar una señal de que se recibieron bien los paquetes (se denomina A por Acknowledgement).

El vector I (I por Information) se subdivide en ranuras para la transmisión de datos de información. El número máximo de

ranuras que una estación puede solicitar es igual al número de ranuras en el marco ó vector I. Ahora bien, suponiendo que el marco I tiene m ranuras de datos, la asignación se hace por prioridad. Por ejemplo, si el número de estaciones es igual a m, cada estación tiene una ranura específica para la cual tiene prioridad uno, otra para la cual tiene prioridad dos, etc. Si una estación no usa su ranura con prioridad uno, entonces se le asigna a la estación que tenga prioridad dos sobre la misma ranura.

Asignación por demanda con prioridad orientada ó Priority-Oriented Demand Assignment (PODA)

PODA es un protocolo de asignación por demanda diseñado para satisfacer eficientemente los requerimientos de una red de propósito general, que incluya soporte para el tráfico de bloques de datos (datogramas) y voz en paquetes, diferentes prioridades y longitudes variables de los mensajes.

- Para los datogramas se utiliza reservación explícita, que generalmente resulta en retrasos hasta de dos "brincos" ó hops por satélite.

- Cada corriente de voz paquetizada utiliza una sola reservación explícita, y los demás paquetes subsecuentes se programan automáticamente a intervalos predeterminados para dar esencialmente retrasos de un brinco.

Con referencia a la Figura 4, el canal de comunicación se divide en dos marcos básicos: un marco de información T_I y un marco de control T_C . El marco de información se emplea para la transmisión de datogramas, corrientes de voz paquetizada, e información de control como reservaciones y señales de recepción correcta; se subdivide en dos secciones: una para asignaciones

centralizadas, I_C , y otra para asignaciones distribuidas, I_D .

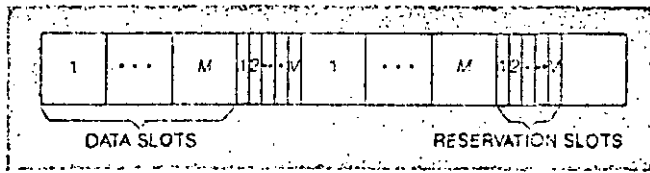
El marco de control se usa para enviar las reservaciones que no puedan enviarse a tiempo en el marco de información, ya que puede haber casos en donde sea muy urgente transmitir ciertos bloques sin poder esperar a tener la oportunidad de reservar dentro del marco de información.

El método de acceso para el marco de control depende de las características particulares del sistema. Si el número total de estaciones es pequeño, se usan asignaciones fijas de una ranura por estación (al igual que en R-TDMA), y el sistema recibe el nombre de FPODA (Fixed PODA). En cambio, cuando se tienen muchas estaciones con ciclo de trabajo bajo, ó estaciones con requerimientos de tráfico muy disímiles, ó bien situaciones donde se desconocen estos requerimientos, se emplea el acceso por contensión, y el sistema recibe el nombre de CPODA (Contention PODA).

En el protocolo CPODA, la duración del marco de control se varía de acuerdo a los requerimientos presentes de programación para la transmisión de los paquetes. Si no hay reservaciones, el marco de control ocupa casi todo el canal de comunicación para reducir la probabilidad de contensión; conforme aumenta la carga del canal, el marco de control se va reduciendo a un valor determinado por la urgencia de los mensajes programados, hasta que alcanza su valor mínimo de duración. Al operar en este estado, todas las estaciones tienen altas restricciones para hacer nuevas reservaciones y solamente se permite que compitan por reservar aquellas con tráfico de muy alta prioridad.

Referencias

- 1.- "Satellite Multiple Access Protocols", C.Retnadhas, IEEE Communications Magazine, Sept. 1980; pags. 16-20.
- 2.- "Protocols & Techniques for Data Communication Networks", editado por Franklin F. Kuo, Prentice-Hall, 1981; Capítulo 5: "Packet protocols for broadcast satellites".
- 3.- "Communications Satellite Systems", J.Martin, Prentice-Hall, 1978; Capítulo 20: "ALOHA channels".



337

Fig. 1. Satellite channel for reservation ALOHA.

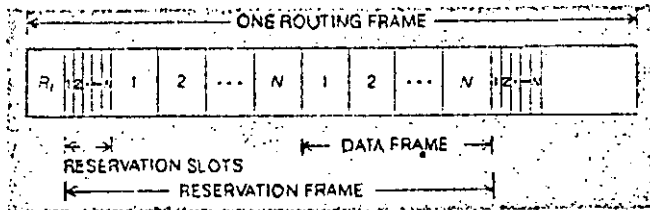


Fig. 2. R-TDMA channel.

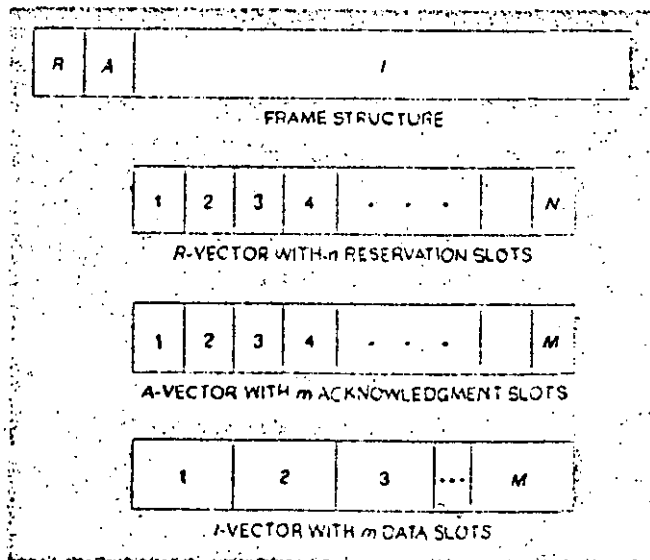


Fig. 3. Frame structure for CFMA channel.

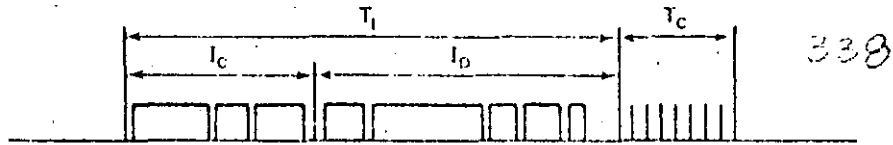


FIG. 4 Priority-oriented demand assignment (PODA).

CENTROS DE LANZAMIENTO

Los centros de lanzamiento para satélites y vehículos espaciales se han ido conformando alrededor de instalaciones creadas inicialmente para la prueba y operación de misiles de largo alcance. Algunos centros se encuentran mucho más avanzados que otros y pocos tienen la capacidad de colocar satélites en órbita geoestacionaria. En el mapa de la página siguiente se indica la situación geográfica de cada uno de estos centros.

VEHICULOS DE LANZAMIENTO

Hasta hace poco tiempo, la mayoría de los satélites de comunicaciones eran lanzados desde Cabo Cañaveral, U.S.A., ó Pleseetsk ó Tyuratam, U.R.S.S. Sin embargo, en 1981, el vehículo espacial Ariane lanzó un satélite indio desde Kourou, Guyana Francesa. El éxito del lanzador Ariane representa una fuerte competencia para el Transbordador Espacial de los Estados Unidos, y ya varios países y organizaciones que inicialmente planeaban lanzar sus satélites a través de la NASA, han hecho sus reservaciones también ó sólomente con Arianspace. Entre ellos se encuentran:

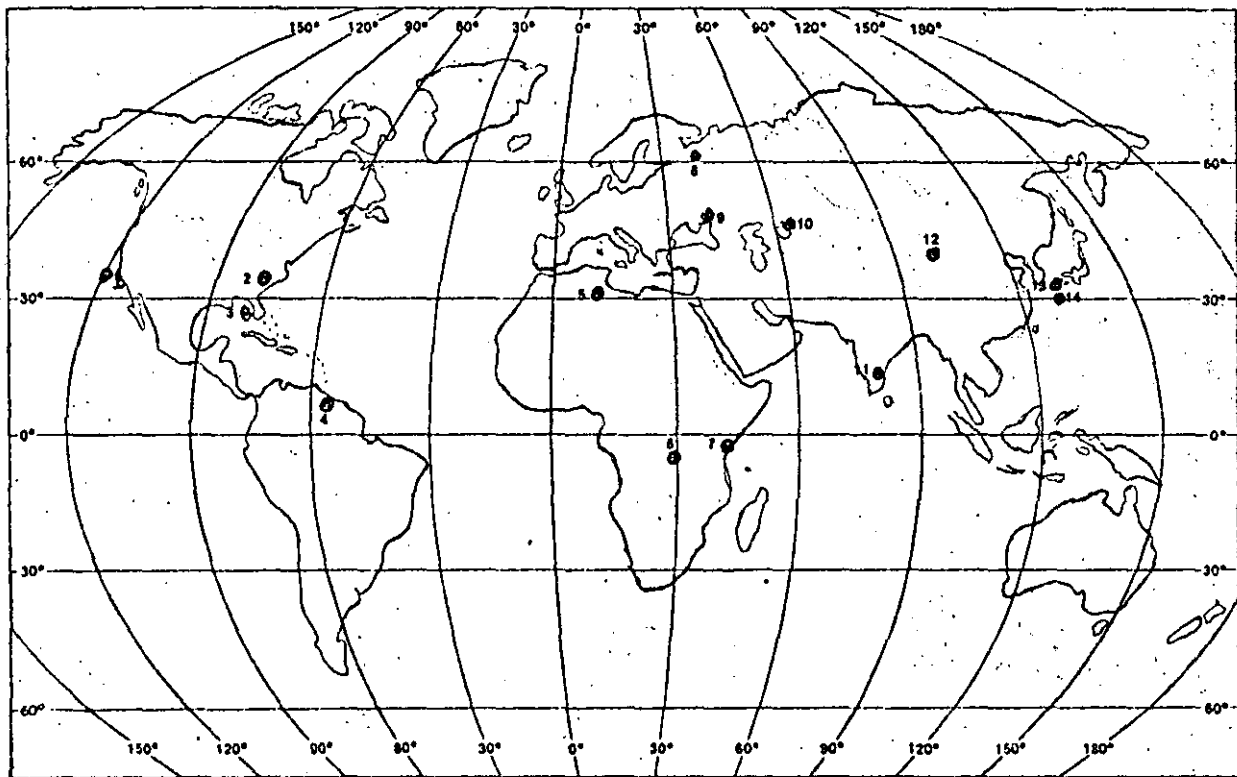
ARABSAT
 COLOMBIA
 WESTERN UNION
 RCA AMERICOM
 AUSTRALIA
 RADIO-TELE-LUXEMBOURG
 SATELLITE TELEVISION CORP.
 BRASIL
 INTELSAT
 SOUTHERN PACIFIC

Los factores que determinan el tipo de vehículo a emplear

Space Launch Centres

- 1 Vandenberg AFB.
- 2 Wallops Island
- 3 Kennedy Space Center.
- 4 Guiana Space Centre.
- 5 OTRAG (Libya)
- 6 OTRAG (Zaire)
- 7 San Marco Platform
- 8 Northern Cosmodrome.
- 9 Volgograd Station
- 10 Baikonur Cosmodrome.
- 11 Sriharikota (SHAR).
- 12 Shuang ch eng-tzu, the 'East Wind' Centre.
- 13 Osaki Launch Site.
- 14 Kagoshima Space Centre.

The premier launch centres in the world are Kennedy Space Center and Vandenberg AFB in the USA, and the Soviet equivalents, Baikonur and the Northern Cosmodrome. Wallops Island and the Volgograd Station launch smaller satellites. The number of countries that participate in space launches, however, has risen sharply since the pioneering efforts of these countries in the late 50s, so that we now see facilities established by France, the ESA-operated, India, Italy, Japan, the PRC and even a private company called OTRAG.



para el lanzamiento de un satélite son:

- órbita de operación del satélite
- peso del satélite

Hasta ahora, el lanzamiento de satélites en órbita geoestacionaria se ha hecho generalmente con cohetes Delta, operacionales desde 1960. Miden aproximadamente 2.5 m. de diámetro por 40 m. de altura en la plataforma. Otros vehículos de lanzamiento son el Scout, Atlas-F y Atlas Centauro. El Scout tiene baja capacidad de lanzamiento (órbitas bajas) y el Atlas Centauro se emplea para trayectorias de escape (naves espaciales) y algunos satélites de segunda generación (Intelsat V y V-A), así como los satélites de la flota de la Marina de los Estados Unidos (FLTSATCOM). Un cohete de este tipo mide aproximadamente 3 m. de diámetro y 45 m. de altura.

Japón cuenta con sus cohetes N-1 y N-2, fabricados con la ayuda de los Estados Unidos y en base a la transferencia de la tecnología del cohete Thor-Delta. Hacia 1982, la NASDA del Japón ya había realizado 6 lanzamientos con el cohete N-1, poniendo en órbita satélites de 85 kg. de peso. El N-2 es capaz de colocar en órbita geoestacionaria satélites de 350 kg. de peso.

Por lo que respecta a los futuros satélites de difusión directa de TV, el mercado será disputado entre los vehículos de lanzamiento Ariane, N-Delta del Japón, Delta y Atlas Centauro de los E.U., además del Transbordador Espacial que es un vehículo recuperable a diferencia de los anteriores que sólo pueden emplearse una vez.

Al final de esta sección se anexa una tabla con los principales satélites que serán lanzados durante los próximos años, y con qué vehículos. Además, se anexan varios artículos sobre el Transbordador Espacial, Ariane, el cohete N y los lanzado-

...3

res de satélites de difusión directa de TV.

COLOCACION EN ORBITA

Casi todos los satélites para comunicaciones son colocados en una órbita geoestacionaria. El proceso consiste de cuatro fases:

- lanzamiento ó ascenso
- órbita de estacionamiento
- órbita de transferencia
- inserción en órbita geoestacionaria

A continuación se describe este proceso al utilizarse un vehículo Delta de tres etapas con nueve motores auxiliares adheridos. En el caso de un Atlas Centauro el procedimiento es generalmente similar.

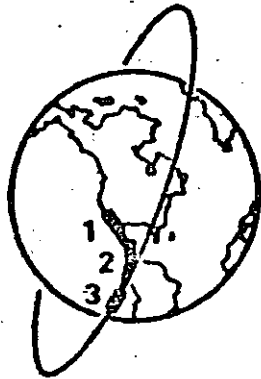
El vehículo inicia su ascenso con el motor de la primera etapa y seis de los nueve motores auxiliares encendidos. Al consumirse estos seis motores, ya con el vehículo en vuelo, se encienden los tres motores auxiliares restantes. A los 2 minutos de haber sido lanzado, el vehículo ya ha alcanzado una altura de 27 millas náuticas y mantiene una velocidad de aproximadamente 5,400 millas/hora. El motor de la primera etapa sigue funcionando hasta alcanzar una altura de 63 millas náuticas y una velocidad de cerca de 12,600 millas/hora. La energía restante necesaria para alcanzar la órbita circular de estacionamiento la suministra el motor de la segunda etapa, el cual se consume 543 segundos después de que se inició el lanzamiento.

Para maximizar la masa satelital que puede colocarse en órbita geoestacionaria, el satélite debe ser inyectado a la órbita de transferencia en el momento en que esté cruzando el

...4

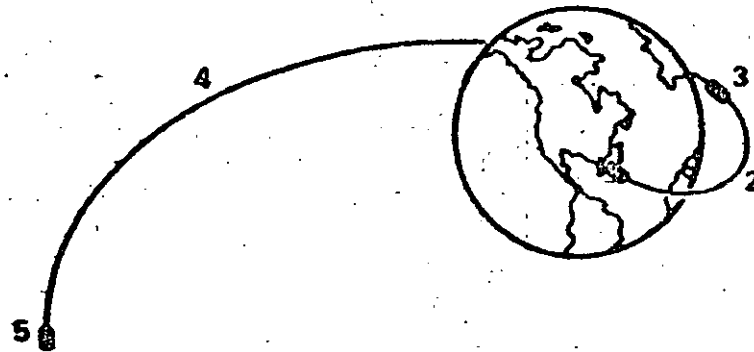
TYPICAL ASCENT TRAJECTORY PROFILES

LOW-EARTH CIRCULAR ORBIT



1. ATLAS POWERED ASCENT PHASE
2. OV1-B/PAYLOAD 3-AXIS STABILIZED BALLISTIC COAST TO TERMINAL ALTITUDE
3. TE 364-4 MOTOR IGNITION TO CIRCULARIZE FINAL ORBIT

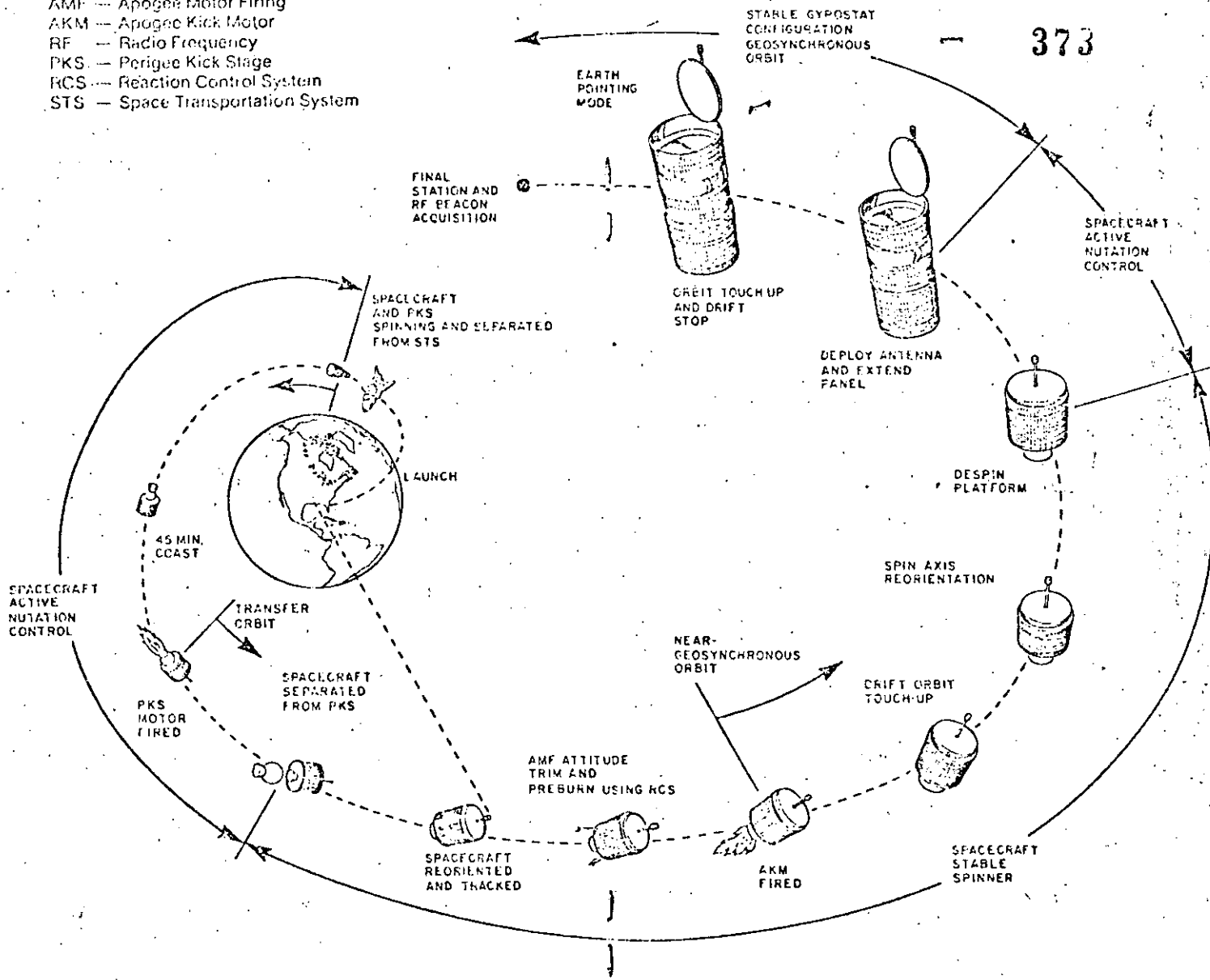
SYNCHRONOUS EQUATORIAL ORBIT



1. ATLAS POWERED ASCENT INTO 172 x 1,320 KM ELLIPTICAL PARKING ORBIT
2. OV1-B/PAYLOAD 3-AXIS STABILIZED COAST TO VICINITY OF EQUATOR
3. TE-364-4-MOTOR IGNITION TO INJECT INTO 314 x 35,800 KM SYNCHRONOUS TRANSFER ORBIT (3-AXIS OR SPIN STABILIZED DURING BURN)
4. PAYLOAD COAST TO SYNCHRONOUS ALTITUDE
5. APOGEE MOTOR IGNITION TO CIRCULARIZE & CHANGE ORBIT INCLINATION

Abbreviations:

- AMF — Apogee Motor Firing
- AKM — Apogee Kick Motor
- RF — Radio Frequency
- PKS — Perigee Kick Stage
- RCS — Reaction Control System
- STS — Space Transportation System



Colocación en órbita con el transbordador espacial Columbia

MANTENIMIENTO DE LA POSICION RELATIVA RESPECTO AL EJE DE LA TIERRA (Satellite Attitude)

Existen dos métodos para estabilizar la posición relativa del satélite con respecto al eje de rotación de la tierra. Esta estabilización es necesaria ya que las antenas del satélite deben apuntar permanentemente hacia la zona que esté recibiendo el servicio. Las dos alternativas son estabilización por rotación del cuerpo del satélite (lo cual involucra rotación simultánea del subsistema de antenas en sentido contrario) y estabilización de tres ejes (que no involucra rotación).

En el caso de estabilización por rotación, las celdas solares están montadas sobre el cuerpo en forma de barril del satélite. Al usar estabilización de tres ejes, con un propulsor ó dispositivo de momento independiente por eje, las celdas solares pueden montarse sobre paneles planos que se orientan óptimamente hacia el sol. Los arreglos solares dispuestos de esta manera son ¶ veces más eficientes que los dispuestos alrededor del cuerpo del satélite (ó sea que para generar la misma potencia, un satélite con estabilización de tres ejes requiere 1/¶ veces menos celdas solares que un satélite rotativo).

Un satélite rotativo maneja del orden de 1 KW de potencia y uno con estabilización de tres ejes y paletas de celdas solares móviles maneja alrededor de 10 KW.

C O M S A T

348

LAUNCH CONTROL CENTER

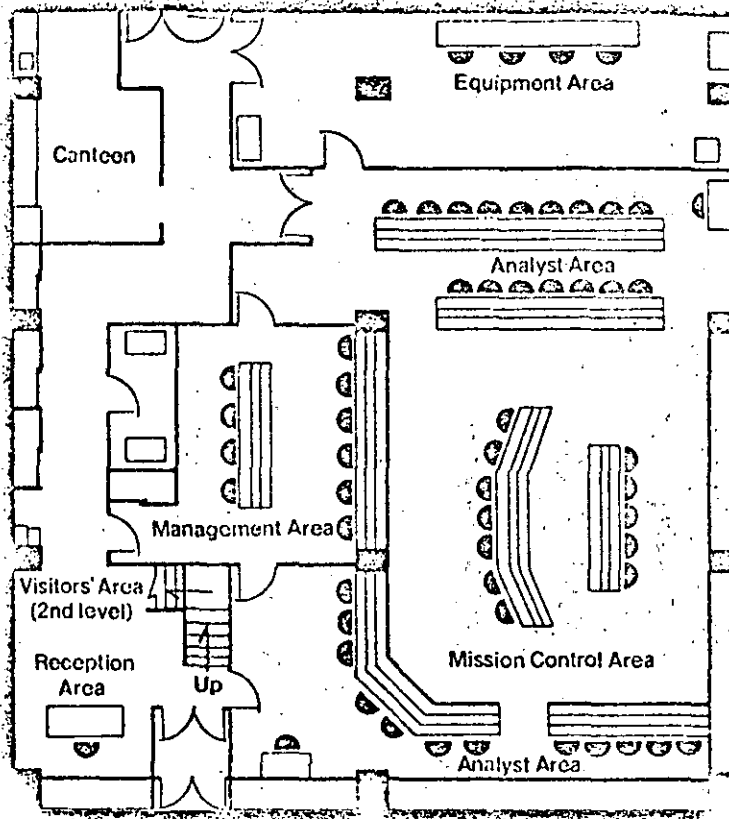
Design Based on Experience

COMSAT has successfully placed into synchronous orbit more than 35 communications satellites, including the most advanced generation of INTELSAT Vs, with a capacity of more than 12,000 circuits plus two TV channels. COMSAT's pioneering efforts in this field began in 1965 with the launching of Early Bird, the world's first commercial communications satellite.

COMSAT designed the Launch Control Center in response to the need for a more versatile facility to meet the data requirements of the most complex satellites of the next decade. These demands are met utilizing the latest in data processing and display capabilities. The LCC has been optimized for launch operations, drawing upon experience gained in more than 15 years of launch, transfer orbit, and subsequent in-orbit operations and systems management.

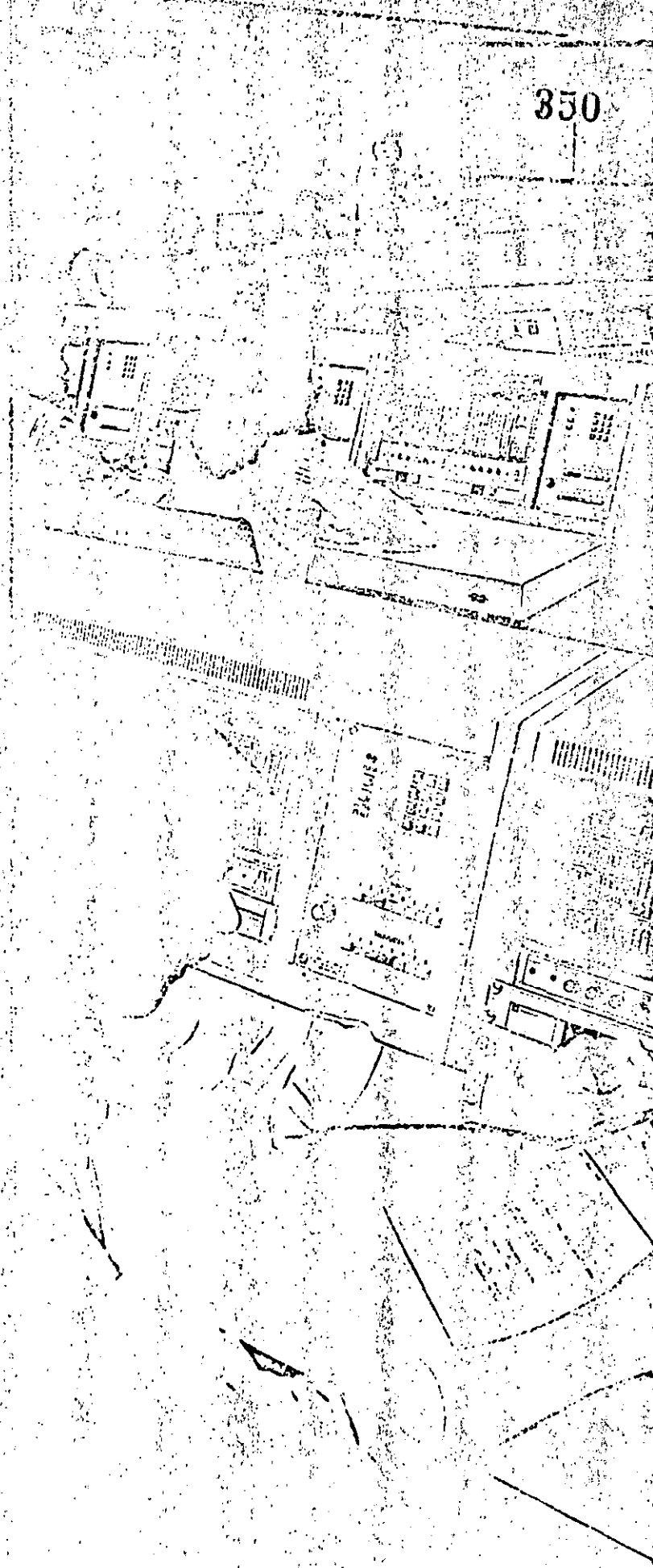
Capable of managing all phases of satellite operations, the Launch Control Center is dedicated to meeting launch and transfer orbit requirements of spin-stabilized and three-axis satellites, including response to in-orbit anomalies or emergencies. The physical layout provides for grouping of related engineering specialists, providing visual contact among the groups, while enforcing operational discipline.

Left: Mission control viewed from Management area.



The facility is divided into several functional areas:

- Equipment Area** - houses the data processing, storage, and control systems.
- Management Area** - provides a central location for the launch and transfer orbit operations.
- Analyst Area** - provides a workspace for the launch and transfer orbit analysts.
- Mission Control Area** - provides a workspace for the mission control specialists.
- Reception Area** - provides a workspace for the reception and distribution of data.
- Visitors' Area** - provides a workspace for the visitors and guests.
- Canteen** - provides a workspace for the staff and visitors.



Flexible and Adaptable

The LCC is equipped with the latest that technology offers. Its flexible data processing system is designed to accommodate a number of spacecraft programs through utilization of appropriate software.

Redundant data processing systems are provided to ensure continuity of operation in the event of a failure of one of the Launch Control Center's processors. In addition, the configuration provides a capability for multiple spacecraft operations or simultaneous real-time and off-line recorded data processing. The dual computers, under executive control, process telemetry and command data received by the LCC. They have extended memory and a switchable I/O extender.

The LCC is equipped with various display and recording devices, including two eight-channel strip chart recorders, a four-channel high-speed light oscillograph, and two 14-track analog tape recorders. The Center interfaces with an IBM 3032 computer system located at COMSAT Laboratories in Clarksburg, Maryland. This system processes incoming telemetry information and is used for orbit determination, maneuver message generation, and real-time graphic displays for monitoring spacecraft maneuvers.

Processed alpha-numeric displays in 20 data formats are distributed throughout the LCC to two CRT's at each console position. Any of the 20 displays can be individually selected on a CRT by thumbwheel selection. A hard copy of the video display can be obtained from either of two separate units.

Left: Mission Control viewed from Analyst area.

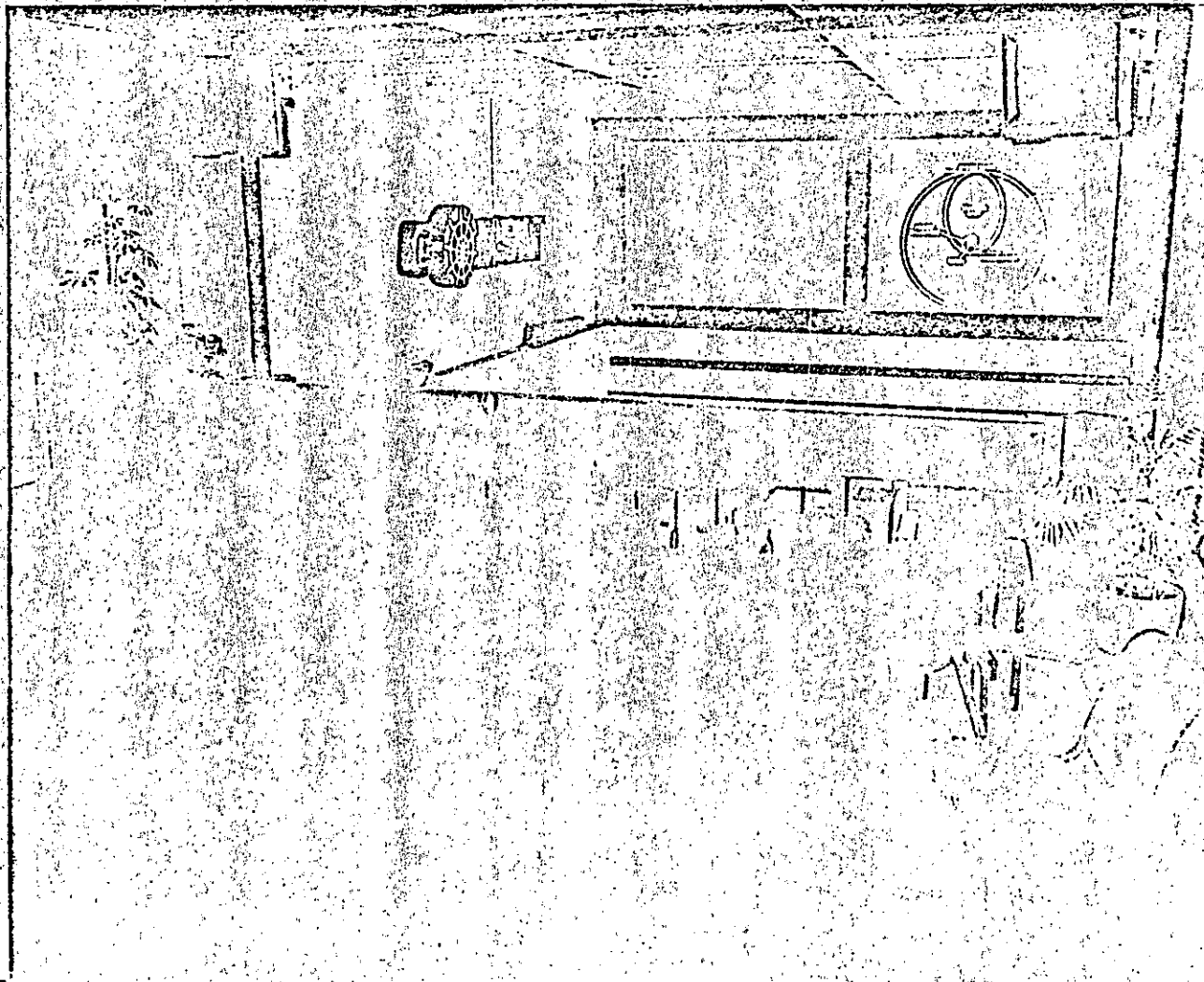
Right: Mission Control area.

Communications internal to the LCC are provided by an eight-channel intercom system which allows users to be active on one network while monitoring other networks. Communications external to the LCC are provided by a computer-driven private phone system which operates independently of the main COMSAT system. External sources, such as incoming or outgoing phone calls, can be routed to any console position or conferenced through a group of positions. These sources also can be interfaced with the intercom system in either an active or monitor mode.

A large screen video projection system can display any of the 20 different computer-generated graphics available in the LCC on one of two screens -- each measuring 10 feet by 7.5 feet -- mounted above the main floor of the facility. Also available for display is an activities schedule, live video from Cape Canaveral or the Center itself, or video taped presentations. The second screen is used for presentation of 35mm slide material. These screens are visible from both the main floor and the visitors' area.

Left: Equipment area.

Below: Visitors' area located above Management area.



SATELITES QUE SERAN

352

COLOCADOS EN ORBITA DE

1982 A 1985

Even more communications in orbit

This latest guide lists the operating characteristics of satellites being launched in the next three years

by the staff of Satellite Engineering Inc., Bethesda, Md.

□ Communications satellites are rapidly revolutionizing the ways in which people communicate by offering such services as video teleconferencing and electronic mail besides the now well-accepted telephone, television, and data transmissions. Approximately 90 active communications satellites orbit the earth today—some 15 more than when Electronics last published this guide on Sept. 11, 1980, and 35 more than in the Oct. 12, 1978, issue. As many as 100 more birds are planned for launch in the next decade.

To obviate any undue repetition, this second update of the guide concentrates on those systems being launched in the next three years that were not described in the 1980 chart. Moreover, systems scheduled for mid-decade or beyond—for example, the U.S. and European direct-broadcasting satellites—are not included since their technical parameters have not been finally set nor their prime contractors selected.

The entries on the chart have been classified in accordance with the International Telecommunications Union usage as fixed, mobile, broadcast, and military. Also indicated is their international, regional, or domestic status. The international category is self-explanatory. Systems are considered regional when they serve a geographical or linguistic grouping, but different political entities are involved. Domestic systems administer to one country only.

Launching options

In the past, most communications satellites were launched either from Cape Canaveral in the U.S. or from Plesetsk or Tyuratam in the USSR. But last year an Indian communications satellite was carried into earth orbit by the French Ariane vehicle launched from Kourou, French Guiana. The success of the Ariane launch presages stiff, low-cost competition for the U.S. shuttle system. In fact, a number of operators who had planned launches with the shuttle have now made firm reservations on Ariane.

Almost all communications satellites are placed into geostationary orbits. After liftoff by means of a booster rocket, the satellite attains a circular low-altitude parking orbit from which it is transferred to a circular geostationary orbit via an elliptical transfer orbit. Firing the perigee kick motor moves the satellite from parking to transfer, and firing of the apogee motor modifies its velocity and moves it into the desired geostationary orbit. During these maneuvers, the mass of the satellite decreases with the diminishing amount of propellant fluid—a fact that, incidentally, complicates satellite mass calculations.

The exception to this positioning process is the Molniya series of satellites, which spin around the earth in a highly inclined elliptical orbit and for most of the time are in view of northern regions of the USSR, such as Siberia. These satellites are used for the Washington-Moscow hotline.

How heavy is it?

The numbers given in the chart for the mass and primary power of satellites are to be used with caution. The mass is generally quoted in operating orbit. But there may be some uncertainty as to whether these numbers do or do not include such factors as on-board propellants. Thus, the mass given is noted as being either an operational figure or one at launch, or beginning of life, as satellite watchers term it.

Even more uncertain are the primary power numbers. These can be quoted at the beginning or end of life and at either the equinox or solstice. Since the total range can be considerable, the probable case is indicated where possible. Otherwise, the best assumption is that the power is the system's at the beginning of its life during equinox.

Only an approximate picture can be given of the kinds of transponders, or satellite channels, and antenna beams available. This is because the system block diagrams of most of these satellites show great variety in redundancy, switching possibilities, and bandwidths. The number of transponders is equal to the number of radio-frequency channels with the bandwidths shown in the appropriate row on the chart.

The satellite receiver figure of merit may have more than one value. These values apply to different beams or transponders or bandwidths, as is evident from the chart.

As noted, some satellite systems are not listed on the chart—even though they will open major communication markets—because they will not be launched until mid-decade and their specifications are not final. Among these are the systems of eight firms in the U.S. that have applied to the Federal Communications Commission to put satellites up to broadcast television programs directly to people's homes. The signals would go directly from the Ku-band (12- to 14-gigahertz) satellites to specially designed small parabolic rooftop antennas. The home receivers that work with these antennas will be the first mass consumer market for gallium arsenide-based microwave integrated circuits [Electronics, June 30, 1982, p. 92].

Reprints of the chart opposite the 1980 chart cost \$5 each. Write to Electronics Dept., 1221 Avenue of the Americas, New York, N.Y. 10020, specifying which chart is being requested. Copyright 1982 Electronics, a McGraw-Hill publication.

357

381

ARTICULOS SOBRE VEHICULOS

DE LANZAMIENTO

354

Systems	INTERNATIONAL FIXED							INTERNATIONAL MOBILE		REGIONAL		
	Intelsat V		Intelsat Va		Intelsat VI		USSR/ Intersputnik Raduga	Inmarsat Marecs		S. E. Asia Palapa 2	Arab League Arabsat	
Prime contractor	Ford Aerospace		Ford Aerospace		Hughes		—	British Aerospace		Hughes		Aerospatiale
Number (and position) of satellites	3 active (22, 24 W, 60 E), 1 spare, 5 more planned with MCS ¹⁰		6 planned (positions not yet determined)		5 contracted for; up to 16 planned (positions not yet determined)		7 active (90 to 35 E) plus 3 in orbit only	1 active (26 W), 2 more planned		2 planned (108, 113 or 118 E)		2 planned (19, 26 E)
Place of launch ¹ and date	CC Dec. 1980, May 1981, Dec. 1981, March 1982		CC first launch 1984; later from CC or KU		CC or KU first launch 1986		TY 1978-81;	KU Dec. 1981, June 1982 planned; third launch undetermined		CC April 1983, Jan. 1984		CC or KU April 1983, Aug. 1984
Launch vehicle	Atlas Centaur		Atlas Centaur or Ariane		shuttle or Ariane		Proton-SL-12	Ariane or shuttle		Thor Delta 3920		Ariane
Service ²	international fixed tel., TVD, TTY, data, and some domestic leases		international fixed tel., TVD, TTY, data, and some domestic leases		international fixed tel., TVD, TTY, data, and some domestic leases		international fixed tel., TVD, and telegraph	mobile tel., TTY		regional fixed tel., TVD		regional fixed tel., TVD
Stabilization	3-axis		3-axis		spin		3-axis	3-axis		spin		3-axis
Mass ³ (kg)	1,870 at launch 1,020 in orbit ¹¹		2,141 at launch 1,160 in orbit ¹¹		3,407 at launch 2,004 in orbit BOL		1,500 at launch	572 BOL		628 in orbit BOL 532 EOL		680 in orbit
Primary power ³ (W)	1,800 BOL 1,300 EOL		see Intelsat V		2,260		700	775 BOL 748 EOL		831 EOL ss		1,300 EOL
Frequencies ⁴	C	Ku	C	Ku	C	Ku	C	L ship	C shore	C	C	S
Number of transponders per satellite ⁵	25	6	32	6	36	10	7	1	1	24	25	1
Transponder bandwidth (MHz)	36 41 72 77	72 77 241	see Intelsat V		36 41 72 77	72 77 150	40	4.75	5.9	36	33	33
Transponder output power (W)	10	10	10	10	10	8.5	40	n. a.	n. a.	10	n. a.	n. a.
Number of antenna beams ⁶	5 Rx 5 Tx	2 Rx 2 Tx	see Intelsat V		7 Rx 7 Tx	2 Rx 2 Tx	2-4 total	1 Rx 1 Tx	1 Rx 1 Tx	1 Rx 1 Tx	1 Rx 1 Tx	1 Tx
Polarization	circular	linear	see Intelsat V		circular	linear	circular	circular	circular	linear	circular	linear
G/T ⁷ (figure of merit, dB/K) and coverage ⁸	-18.6 gl -11.6 he - 8.6 zo	0 es 3.3 ws	see Intelsat V		-15.0 gl -8.5 he -7.0 zo -1.0 zo	1.0 es 4.3 ws	-15.8	18.8 per carrier	-2.5 per carrier	-5 Indonesia -7 ASEAN	-7.5	-7.5
Effective isotropic radiated power ⁹ (dBW)	23.5 gl 26.5 gl 26 he 29 he 29 zo	41.4 es 44.4 ws	see Intelsat V		23.5 gl 31 he 28 zo	41.1 es 44.4 ws	25 to 36	32	32	34 Indonesia 32 EOC	31 min	41 min
Saturation flux density (dBW/m ²) (single carrier)	-75 gl, he -72 gl, he -72 zo	-77 es -80 ws	see Intelsat V		-77.6 (adjustable)	-78.4 es -81.3 ws	n. a.	-85 to -106 (adjustable)	-123	-89.5	n. a.	n. a.

¹CC - Cape Canaveral, USA
²KU - Kourou, French Guiana
³PL - Pleiades, USSR
⁴TY - Tyuratam, USSR
⁵TA - Tanegashima, Japan

⁶fixed - satellite service to specified fixed points
⁷mobile - satellite service to ships, airplanes and mobile ground terminals
⁸bricast - satellite service intended for reception by the general public
⁹BOC - broadcast (one-way) satellite service
 gl - geophony
 he - telephony
 he - teletype
 TVD - television distribution

¹⁰BOL - beginning of life
¹¹EOL - end of life
 ss - summer solstice
 eq - autumnal equinox

COMMUNICATIONS SATELLITES

FIXED		FOREIGN FIXED											
Eutelsat ECS	France Telecom	Telesat Canada Anik C	Telesat Canada Anik D	Australia Ausat	India Insat	Japan CS	RCA Satcom V-VIII	Western Union Westar IV-VI	Western Union Advanced Westar/TDRSS				
Mesh	Matra	Hughes	Spar Aerospace	Hughes	Ford Aerospace	Mitsubishi (Ford Aerospace contractor)	RCA Astroelectronics	Hughes	TRW				
5 planned (10 to 12 E)	2 planned (7, 10 W)	3 planned (112.5, 116, 109 W)	2 planned (104, 114 W)	3 planned (156, 160, 164 E)	2 planned (74, 94 E)	1 experimental active (135 E), 2 more planned (130, 135 E)	4 planned (132, 83 W, n.a., n.a.)	1 active (99 W), 2 more planned (123 W, n.a.)	5 planned, incl 1 spare (41, 79, 91, 191 W)				
KU or CC Jan. 1983	KU Sept. 1983, Dec. 1983	CC Nov. 1982, April 1983, April 1984	CC Aug. 1982, Oct. 1985	KU or CC 1985	CC April 1982, July 1983	CC Dec 1977, TA Jan/Feb. 1983, Aug/Sept. 1983	CC Nov. 1982, March 1983, Dec. 1983, early 1984	CC Feb. 1982, June 1982, CC or KU late 1983	CC Jan. 1983, July 1983, Jan. 1984, May 1984				
Ariane	Ariane	shuttle or Thor Delta 3914	shuttle or Thor Delta 3910	Ariane, shuttle, or Thor Delta	Thor Delta 2914 or shuttle	Thor Delta 2914 N-2	Thor Delta 3910	Thor Delta 3910	shuttle				
regional tel., TVD	regional fixed tel., TVD	fixed tel., telegraph, data, TVD	fixed tel., telegraph, data, TVD	fixed tel., radio, data, TVD	fixed tel., TTY, meteorological data, TVD	fixed tel., TTY	fixed tel., TVD	fixed tel., telegraph, data, TVD	fixed tel., telegraph, TVD				
3-axis	3-axis	spin	spin	spin	3-axis	spin	3-axis	spin	3-axis				
1,030 at launch	1,142 at launch 653 in orbit BOL	1,090 at launch 567 in orbit BOL	635 in orbit BOL	600 in orbit approx.	1,152 at launch 600 in orbit	675 at launch 350 BOL	598 in orbit	584 in orbit	2,132 in orbit				
642 EOL	1,045 EOL	1,122 BOL ss	1,000 BOL ss	1,054 BOL ss	1,250 BOL 1,150 EOL ss	538 BOL eq 375 EOL ss	1,000 average	822 BOL 684 EOL	1,700 EOL				
Ku	C Ku	Ku	C Ku	C Ku	C S	C K	C	C	C Ku				
12 (9 activated)	6 6	16	24	15	4 2	2 6	24 all solid state	24	12 4				
80	40 120	36	54	36	45	36 0.2	180 to 200	130 to 200	34	36	36	225	
20	8.5	20	15	20	12, 30	4.5, 50 0.6	5	6	8.5	7.5	5.5	15, 30	
2 Rx 4 Tx	2 Rx 3 Tx 1 Rx 1 Tx	2 Rx 4 Tx	1 Rx 4 Tx	5 Rx 7 Tx	1 Rx 2 Tx	1 Rx 2 Tx	1 Rx 1 Tx	1 Rx 1 Tx	2 Rx 2 Tx	1 Rx 1 Tx	1 Rx 1 Tx	7 Rx 7 Tx	
linear	circular	linear	linear	linear	linear	linear	circular	circular	circular	linear	linear	linear	circular and linear
-5.3	-13.6 6.5	3	-37.5 -27 -28	-3	-4.3 -3.4	-16.2	-8	-5	-5 Conus, AK -10 HI	-6 Conus -7.5 AK -10.9 HI, PR	-7 Conus -13 HI	-5 to 4.4	
34.8 Eurobeam 40.8 spot	26.8 to 35.4	47.5	48	36	36 national 42 spot 47 spot	33 43.2	22.4	29.5 EOC	37 EOC	34 Conus 26 HI	34 Conus 31 AK 28.3 HI 27.2 PR	33 Conus 26 HI	42 to 50.3
-76.2 max -89.9 min	-70	-91	-80	n.a.	-90 to -75 (adjustable)	-90 to -72 (adjustable)	n.a.	-74	-80 Conus nom -84 Conus op -75 HI	-80 Conus -78.5 AK -75.1 HI, PR	-80 Conus -72 HI	-78 -75 -90	

300 to 3,000 MHz X¹ - 7,250 to 7,750 MHz
 1,530 to 2,700 MHz 7,900 to 8,400 MHz
 2,500 to 2,700 MHz sh² - 3 to 30 GHz
 3,400 to 4,200 MHz Ku - 10.95 to 14.5 GHz
 4,300 to 4,700 MHz Kc - 17.7 to 21.2 GHz
 5,725 to 6,425 MHz K - 27.5 to 31.0 GHz

⁵ Number of transponders - available communications channels, except when C and Ku bands share transponders, whereupon the number of simultaneously active transponders becomes less than the theoretical maximum obtained by channel summation; spares are not counted.

⁶Rx - receive
Tx - transmit

⁷g - global
h - hemispheric
z - zonal
e - east spot
w - west spot

⁸Conus - CONUS
AK - ASEAN

U.S. FIXED							MILITARY						
GTE G Star	Southern Pacific Communications Spacenet		Hughes Galaxy	AT&T Telesat	Satellite Business Systems SBS	American Satellite ASC	United States Satellite Systems Inc. USAT		USA OSCS II	USA DSCS III	NATO III	Hughes Leasat	
RCA Astroelectronics	RCA Astroelectronics		Hughes	Hughes	Hughes	not yet chosen	not yet chosen		TRW	GE Space Division	Ford Aerospace	Hughes	
3 planned (103, 106, 87) or 119 W	3 planned, incl. 1 spare (119, 70 W)		3 planned incl. 1 spare (74, 135 W)	3 planned (95, 87, 128 W)	2 active (100, 97 W) and 1 planned (94 W)	3 planned, incl. 1 spare (122, 88 W)	3 planned, incl. 1 spare (88, 122 W)		14 active, 1 more planned	12 planned	3 active, 2 more planned	4 planned	
KU or CC April 1984 late 1984 early 1985	CC or KU 1984		CC or KU 1983 or 1984	CC 1983 or 1984	CC Nov. 1980, Sept. 1981, Nov. 1982	CC or KU Oct. 1985, March 1986	CC or KU 1985		CC 1971 to 1979, 1982 or 1983	CC 1982 or 1983	CC April 1976, Jan. 1977, Nov. 1978	CC 1984 or 1985	
Ariane, Thor Delta or shuttle	Thor Delta 3920 or Ariane		Thor Delta 3920 or Ariane	Thor Delta 3910 shuttle	Thor Delta 3920 shuttle or Ariane	Thor Delta 3920 shuttle or Ariane		Titan III C	Titan III C or shuttle	Thor Delta 2914, 3913	shuttle		
fixed data and possibly DBS	fixed tel. telegraph data, TVD		fixed tel. data, TVD	fixed tel. telegraph data, TVD	fixed data, TVD	fixed TVD, voice, data	fixed tel. data, TVD		fixed/mobile military	fixed/mobile military	fixed military tel. TTY	mobile military	
3-axis	3-axis		spin	spin	spin	not yet determined	not yet determined		spin	3-axis	spin	spin	
670 in orbit 80L	670 in orbit		1,073 at launch 476 80L	659 in orbit 80L	900 at launch 546 in orbit	1,220 at launch	668 in orbit 80L		538 80L	748 80L	349 80L	1,427 60L	
1,350 EOL eq	1,150		670 EOL	917 EOL 800 EOL	900 EOL	not yet determined	1,680 EOL eq		520 80L	1,100 80L 857 EOL	538 80L eq	1,210 EOL	
Ku	C	Ku	C	C	Ku	C	Ku	Ku	X	X	X	uhf, shf	
16	18	6	24	24	10	18	8	20	4	8	2	9	
54	36	72	36	36	43	36, 72	72	49	410 total	395 total	17 85	0.5 0.025	
20, 30	8.5, 16	16	8.5	5.5	20	7.5, 10	20	10, 20	20	10, 40	23	n.a.	
3 Rx 3 Tx	2 Rx 2 Tx	1 Rx 1 Tx	1 Rx 3 Tx	1 Rx 4 Tx	1 Rx 1 Tx	multiple array	3 Rx 5 Tx	3	multiple array	2	2 Rx 2 Tx		
linear	linear	linear	linear	linear	linear	linear	linear	linear	circular	circular	circular	circular	
-1.5 to -4.8	-5 to -4	-3 to -2	-7 edge of Conus	-5 edge of Conus	+2 to -2	-4 Conus -7 PR -9 AK HI	-5 Conus -2 primary	-2 Conus -7 AK -4 HI	6.5 20.2	-16 to -1	-14.1	-16 (uhf)	
40 to 42	33 to 35 36 to 38	40 to 44	34.5	34 edge of Conus	40 to 43.7	34 Conus 36 Conus 27, 29 PR 28, 30 HI 31, 33 AK	39 Conus	40 Conus 35 to 38 AK, HI	28 40	23-40	35 29	28 (uhf) 26 (uhf) 16.5 (uhf)	
n.a.	-80 to -79 or -86 to -85 (adj.)	-79 to -80 or -85 to -86 (adj.)	n.a.	n.a.	-82 (for G/T, -2)	-80 Conus -77 PR -75 AK HI	-77 Conus	-78 to -80 nom	-84 -78	n.a.	n.a.	-157 to -113 (uhf)	

Environmental U.S. (hour Alaska, Hawaii, etc.)
 location of Southeast Asia Nations
 in Rio

Values usually nominal
 max = maximum
 min = minimum
 op = operational
 n.a. = not available
 EOC = edge of coverage
 COB = center of beam

OMCS - maritime communications subsystem for mobile land services to be leased by Inmarsat
 Mass after firing apogee motor

THIS CHART WAS COMPILED BY SATELLITE SYSTEMS ENGINEERING WASHINGTON, D.C. 1987 ELECTRONIC INDUSTRIES INC. MCGRAW-HILL

LAUNCH VEHICLES FOR COMMUNICATIONS SATELLITES

JOSEPH B. MAHON

National Aeronautics and Space Administration

The United States currently maintains and operates a balanced family of space launch vehicles. These vehicles provide the capability to launch a wide variety of space missions such as planetary probes, meteorological and astronomical observatories, and communications satellites. The ability of current launch vehicles to launch communications satellites is a matter of considerable importance and is the subject of this paper.

CURRENT LAUNCH VEHICLES

The current civilian space launch vehicle inventory is listed below. The vehicles range in size from the Scout, intended for launching small (a few hundred pounds) spacecraft into Earth orbit, to the Atlas Centaur, designed to launch high energy planetary missions into escape trajectories. Of the vehicles shown, two are the primary launchers of communications satellites--the Delta and the Atlas Centaur. While the Titan IIC has geosynchronous capability, it has not been used by commercial users to launch communications satellites.

Launch Vehicle	Low Earth Orbit/300 Inject'n Wt/Lb	Transfer Orbit Inject'n Wt/Lb	Weight in Geo-sync Orbit/Lb
Scout	450	-	-
Delta	6,600	2,750	1,380
Atlas-F	3,000	-	-
A/Centaur	11,500	5,050	2,500

Delta Launch Vehicle

The Delta was originally a combination of the Thor military ballistic missile and the upper two stages of the Navy Vanguard launch vehicle. Over its life, all three stages have evolved and changed. The vehicle is currently being offered with two third stages for

selection by the user--an updated version of the Thiokol solid motor (Star 37) or the newly developed Star 48 motor. Two versions of the Castor motor are available for strapping to the core vehicle to augment the thrust developed by the first stage.

The Delta launch vehicle has been operational since 1960 and has been used for over 160 space launches. It is eight feet in diameter and about 115 feet tall standing on the pad ready for launch. The Delta is the most frequently used U.S. launch vehicle and has launched most of the commercial communications satellites to date. Its performance and cost have made it an attractive vehicle for first generation communications satellites.

NASA plans to provide Delta vehicles as long as they are needed during the transition period to the Space Shuttle. For the present planning, six launches are planned in Fiscal Year 1982, seven in Fiscal Year 1983, nine in Fiscal Year 1984, and nine in Fiscal Year 1985. I have not included projections for Delta usage well into 1985 because the lead time for vehicle fabrication permits delaying the decision to proceed on these vehicles for about a year. It does appear that the demand for Delta will continue into 1986.

Atlas Centaur Launch Vehicle

The Atlas Centaur is an all-liquid propellant, two-stage launch vehicle. The first stage is a modification of the early Atlas ICBM, stretched and updated to provide greater performance. The second stage is the Centaur--NASA's first operational stage using hydrogen/oxygen propellants.

The Atlas Centaur has been operational since about 1965 and has been used for over 60 launches. It is ten feet in diameter and about 130 feet tall. It was first used to launch the

Surveyor spacecraft which soft-landed on the Moon. The Atlas Centaur has subsequently been used for launching a variety of missions, including planetary probes and larger, more sophisticated second-generation communications satellites. It is currently being used to launch the INTELSAT-V and VA series of spacecraft, as well as the Navy fleet communications satellites.

NASA planning for Atlas Centaur includes launchers through 1985 for INTELSAT-VA, and through 1986 for PITSATCOM. It could be available on a three-year lead time notification to prospective users for larger communications satellites, including the direct broadcast type.

COMMUNICATIONS SATELLITE ORBITS

The U.S. and other Western satellite developers have preferred to place communications satellites in the geostationary orbit where the spacecraft remains stationary with respect to the Earth, directly above a point on the equator. This result is achieved by a unique combination of orbital period, eccentricity, and inclination--the orbital period of the spacecraft being 24 hours equal to the Earth's rotational period; the orbital eccentricity being zero, resulting in a constant spacecraft velocity throughout the orbit; and the orbital inclination being zero, meaning the orbital plane is in the plane of the Earth's equator.

The advantage of the geostationary orbit is the constant position of the satellite with respect to ground stations, which greatly simplifies the operation of the ground stations. However, for ground stations at high latitudes, the satellite in the geosynchronous orbit is near the horizon, a situation less than ideal for communications links. Some communications, therefore, employ an inclined elliptical orbit with a period of 12 hours. While this orbit does not allow continuous communications between a ground station and a satellite, the orbit geometry causes the spacecraft to hover above a specific ground location for a substantial part of the orbit.

TYPICAL LAUNCH TRAJECTORY

The delivery of a communications

satellite to the popular geostationary orbit occurs in four steps or phases: launch or ascent, parking orbit, transfer orbit, and orbital insertion.

Using the Delta 3920/PAM (a three-stage Delta vehicle with nine strap-on Castor motors) to illustrate these phases, the launch profile is described. The profile for Atlas Centaur would be generally similar. In either of these cases, the launch would be from the Eastern Space and Missile Center in Florida.

Ascent begins at vehicle lift-off when the first stage main engine and six of the nine Castor solid motors are ignited. Only six are ignited to keep the vehicle accelerations down. Following the burn of the six Castors, the remaining three are ignited in flight. The entire sequence of Castor motor burns takes about two minutes, at the end of which the vehicle has risen to a height of 27 nautical miles and has attained a velocity of approximately 8000 feet per second (5400 miles per hour). From this point, the first stage main engine propulsion system continues operating, reaching cut-off at an altitude of 63 nautical miles and a velocity of about 18,500 feet/sec (12,600 miles/hour). The remaining energy to achieve orbit is supplied by the second stage, cut-off occurring at 543 seconds after lift-off.

For geostationary orbits, the spacecraft mass that can be delivered is maximized by injecting it into the transfer orbit at an equatorial crossing. Therefore, the Delta second stage (with partial propellant load remaining), the third stage (payload assist module), and the spacecraft must coast in the parking orbit until the proper time for the injection burn. The injection burn is normally completed at the first equatorial crossing; the second and third stages are both used for this burn, which accelerates the spacecraft to a velocity of 33,600 ft/sec (22,800 miles/hour).

The transfer injection burn occurs at an equatorial crossing, i.e., at a node of the parking orbit, which places the spacecraft into a transfer orbit with apogee at geosynchronous altitudes. To achieve geostationary orbit, another velocity impulse must be applied at the apogee of the transfer orbit to remove the orbital inclination due to

the launch site latitude and to circularize the final orbit. This final velocity increment can be supplied by the launch vehicle upper stage or by the spacecraft. The current practice for Delta and Atlas Centaur launches of communications satellites is for the spacecraft to insert itself into final orbit. To do this, the spacecraft must include a sizeable propulsion system, typically, a solid propellant motor. As a rule of thumb, the mass of the apogee motor will be approximately the same as the mass of the rest of the communications satellite. Thus, for an estimate of the final mass in geostationary orbit, the quoted geosynchronous transfer injection mass for a given launch vehicle should be divided by two.

HISTORICAL AND PROJECTED COMMUNICATIONS SATELLITES

The extent of past and projected communications satellites is illustrated below. The launches have been grouped into four time periods and two mission classes. The class labeled International includes INTELSATS and early experimental satellites, such as Early Bird and Syncoms; the Regional class includes the domestic communications satellites (i.e., Westar, Marisat) and regional national systems, such as the ANIK or Palapa series. The four launch periods are five year intervals to reflect the early period (1965-1970), two mid periods to reflect launch levels (1971-1976 and 1977-1981), and, finally, 1982 and beyond. Not included in this projection are launches of communications satellites by the Space Shuttle. As can be seen, the pace is expected to continue and increase in the future.

Mission Class	Years			
	65-70	71-76	77-81	82-85
International	13	13	9	10
Regional	0	10	18	24

Director, Expendable Launch Vehicles, National Aeronautics and Space Administration, Washington, DC 20546

Director of NASA's Expendable Launch Vehicles Program. Responsible for NASA's family of expendable launch vehicles, completing nearly 200 successful space launches of scientific satellites and observatories, lunar and planetary probes and satellites, as well as communications satellites for commercial organizations.

Previous experience included employment by the Navy Department as Systems Engineer for the Polaris missile and Senior Project Engineer of the Sparrow air-to-air guided missile.

Holds a B.S. in Mechanical Engineering from Catholic University.

Earned NASA Distinguished Service Medal for efforts in Launch Vehicles, NASA Exceptional Service Medal for work on the Agena Program which resulted in the first U.S. spacecraft landing on the Moon, and Secretary of Navy Certificate of Commendation for work on the Polaris missile.

ATLAS AND CENTAUR ADAPTATION AND EVOLUTION—27 YEARS AND COUNTING

H. M. Bonesteel

Atlas/Centaur Program Director
General Dynamics Convair Division

ABSTRACT

The Atlas and Centaur launch vehicles have evolved and adapted since 1955 to provide the spacecraft community with a highly reliable launch system. The production and launch events of these vehicles are described, the environment provided to a spacecraft is detailed, and the payload performance and accuracy of the launch vehicle system are presented.

INTRODUCTION

There is a story about two astronauts sitting atop their launch vehicle somewhat apprehensively discussing their fate being in the hands of a "stack of low-bid" hardware.

No doubt a number of you have, at times, had some of the same misgivings as your "electronic astronauts" waited to be propelled into space. Perhaps you would have been more comfortable had the equipment been carried aboard a vehicle with a little more "heredity" or "lineage".

Two vehicles that have always been extolled as examples of durable and long-term production runs have been the innovative Ford Model T and the venerable DC-3. The Model T was in continuous production from 1909 to 1927 and the DC-3 from 1934 until 1945 (people seem to forget the A4 Skyhawk that was built for 26 years). The reasons these products were produced for such a long time were:

1. They were good, reliable products.
2. They evolved and improved to meet the needs of their users.

There is another vehicle that meets those same criteria and has been in continuous production since 1955 — longer than the Ford, the Cooney, or the Skyhawk — and that is the Atlas (Figure 1). From its beginning as an intercontinental ballistic

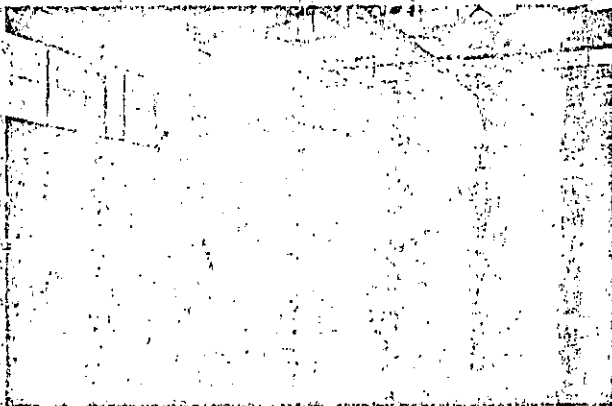


Figure 1. Atlas and tank after welding.

missile over a quarter century ago until the present day, it has evolved, improved, and adapted to serve the United States Space Program like no other vehicle. From John Glenn to Voyager, Atlas and its heir, the Centaur, have provided that "stack of low-bid" hardware for almost 500 launches.

ATLAS

From its beginning in 1955, Atlas has progressed through the years until today there exists a "family" of vehicles still expanding in capability and reliability.

Figure 2 is today's "family portrait." The three vehicles on the right, together with other versions, are being considered in advanced studies as we adapt to survive in the Shuttle era.

CENTAUR

The "youngest" in the Convair launch vehicle stable is the Centaur (Figure 3). The world's first liquid hydrogen launch vehicle, the Centaur has been in continuous production since 1960 (only 22 years). Even a quick examination of the Centaur will show its family resemblance to Atlas. This vehicle developed directly from the Atlas technology of the late 1950s, but it, too, has been shaped and reshaped to meet the needs of the spacecraft community. Today it is being improved again to provide even more capability for the INTELSAT-VA spacecraft to be launched in 1984.

ATLAS AND CENTAUR

Atlas and Centaur have faced the trials that all new vehicles seem to have to endure. (Table 1 indicates that launch vehicles can expect four failures out of the first ten tries. This appears to have been a common pattern with the exception of the Saturn

Table 1. New launch vehicles require many flights to achieve high reliability.

	Early Mission Success (%)			Total Flights	Current Operational Reliability (%)
	First 5	First 10	First 15		
Lower Stages					
Thor (space launches)	60	70	80	500	96
Atlas (space launches)	60	70	68	466	96 (SLV)
Titan III	100	100	100	124	99
Lower Stage Average	73	80	82	358	97
Upper Stages					
Agona	60	70	73	352	96
Centaur	60	70	73	66	100 (D-1)
Transago	80	60	73	37	92
Upper Stage Average	67	67	73	149	96
Vehicle average (lower X upper stage)	49	54	60	N/A	93

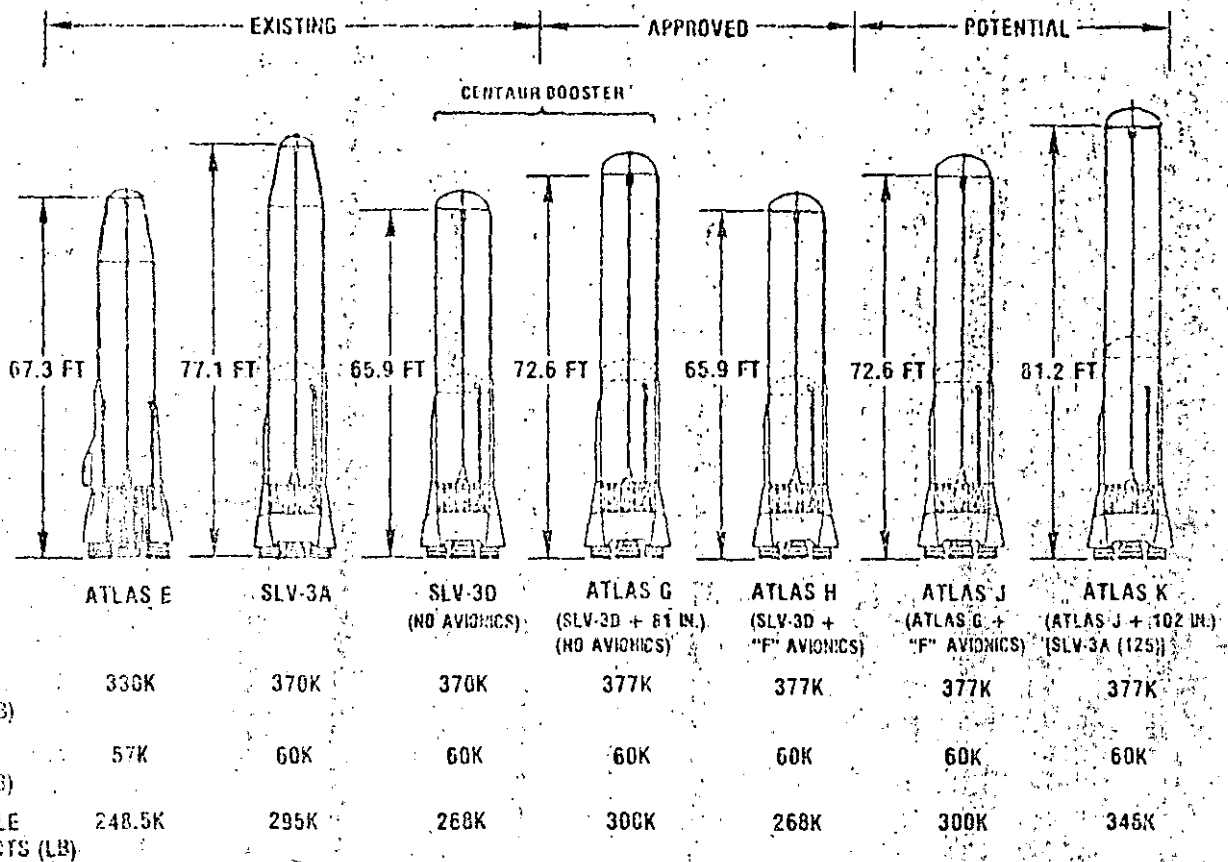


Figure 2. Atlas vehicle family.

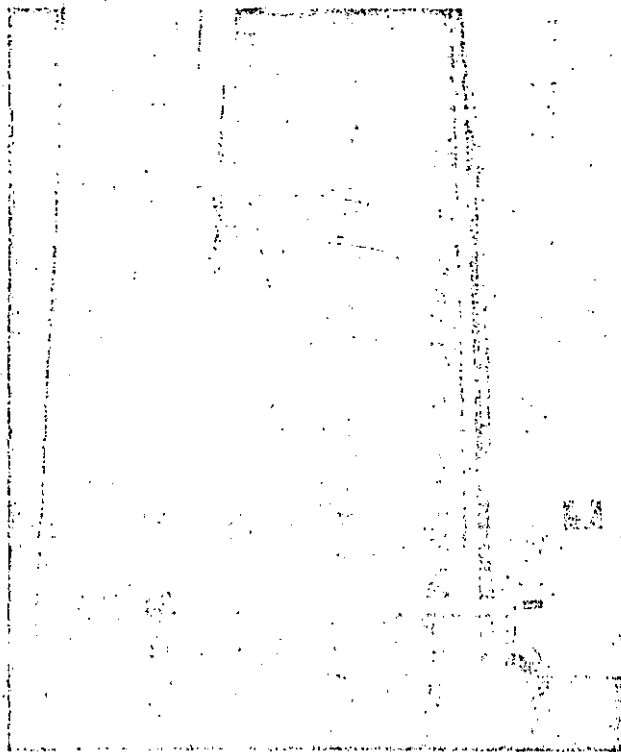


Figure 3. Centaur vehicle in hoist for welding operation.

series (and hopefully the Shuttle). Together, Atlas and Centaur have provided 25 years of successful launch vehicle experience (Figure 4).

ATLAS & CENTAUR — HOW THEY ARE BUILT

The Atlas and Centaur vehicles are unique. They are fabricated (Figure 5) of thin (0.014 in. — 0.041 in.) stainless steel skins with no (that's none) internal supporting structure. The skins are welded together to provide sealed tanks for holding the liquid oxygen (LO₂) and kerosene (RP-1) for the Atlas and LO₂ and Liquid Hydrogen (LH₂) for the Centaur. Like a football or basketball, the strength and stability of the tanks are maintained by pressurizing the tanks at all times and utilizing sensing systems to prevent undesired deflation.

A skin stringer and fiberglass section encloses the Rocketdyne booster engines at the aft end of Atlas while a similar skin stringer structure is used to connect the Centaur to the Atlas and provide a cover for the Pratt & Whitney Centaur engines. Insulation panels on the sides of the Centaur prevent the formation of liquid air when the vehicle is loaded with liquid hydrogen and a fiberglass and aluminum nose fairing provides payload accommodations. The total assembly is finished in San Diego and air shipped to Cape Canaveral for launch from Complex 36.

LAUNCH SITE OPERATIONS

At the Cape, all spacecraft operations are essentially independent of the launch vehicle preparations prior to encapsulation into the nose fairing for installation on the launch vehicle (Figure 6). Subsequent to an integrated countdown, the

Atlas/Centaur		Titan/Centaur
Payloads (58) Test Flight (8) Surveyor (7) ATS (2) OAO (3) Mariner Mars (4) Intelsat IV (6) Intelsat IVA (6) Pioneer F (1) Pioneer G (1) MVM (1) Comstar (4) HEAO A (1) HEAO B (1) HEAO C (1) Flitsatcom (5) Pioneer Venus (2) Intelsat V (4)		Payloads (7) Test Flight Helios A Helios B Viking A Viking B Voyager 1 Voyager 2

Figure 4. Launches -- 1957-1982.

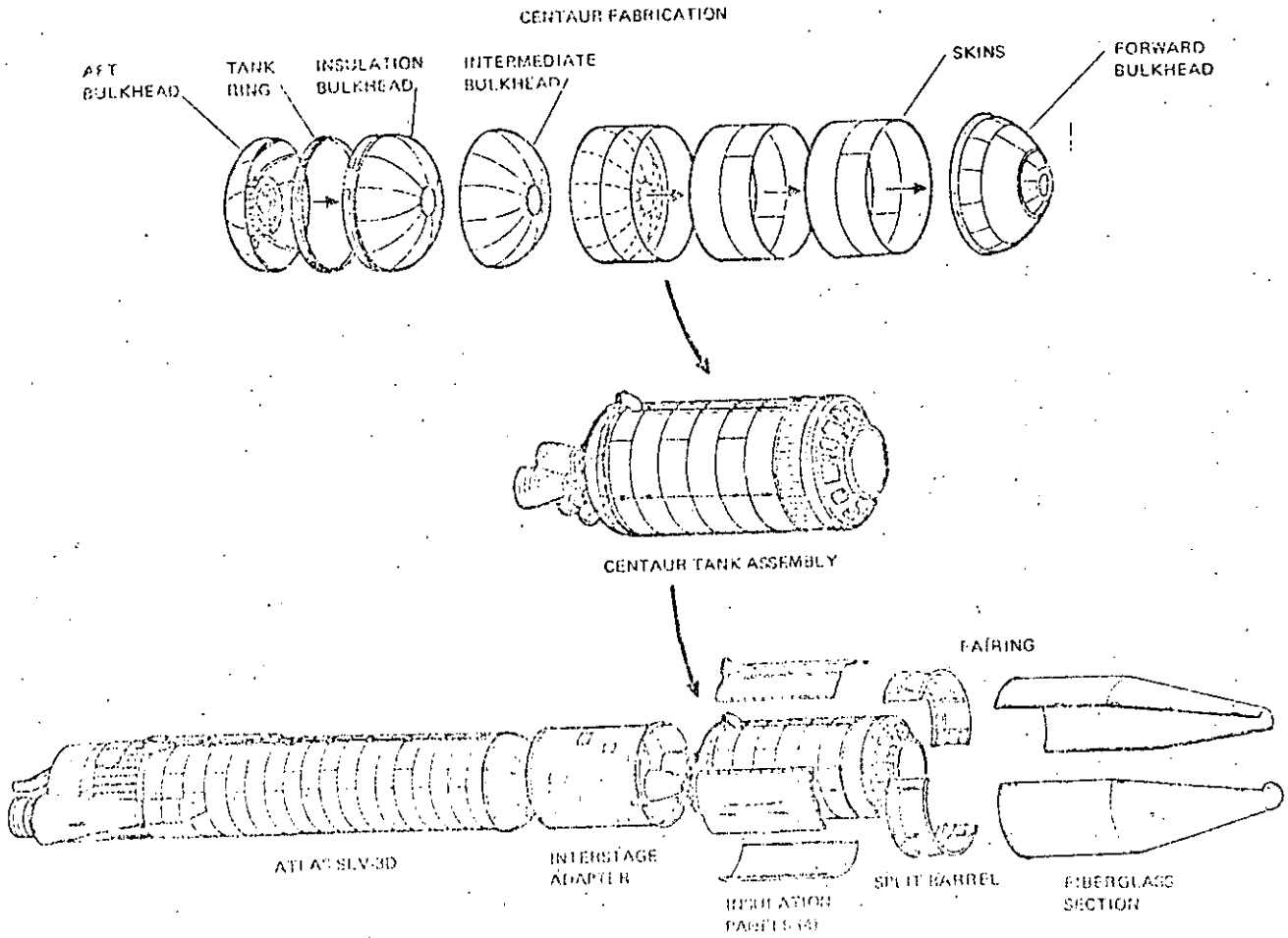


Figure 5. Fabrication sequence.

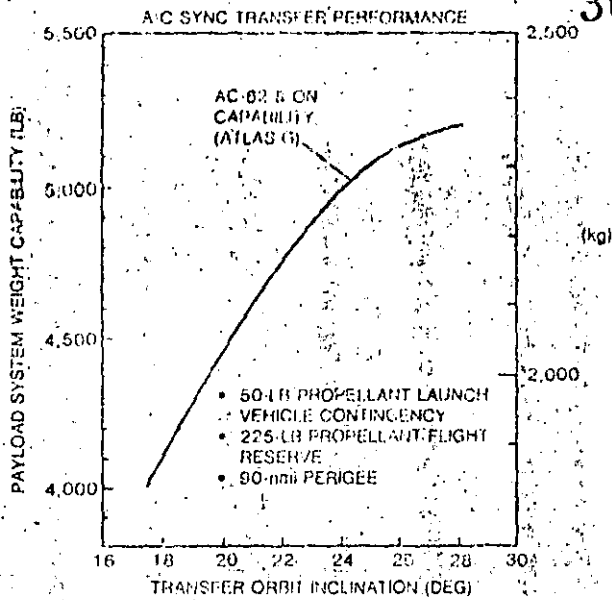


Figure 8. Synchronous transfer performance capability for Atlas/Centaur vehicles.

vehicle ensures an excellent chance of a successful mission. The demonstrated reliability of the Atlas/Centaur over the last five years has been 100%.

Table 2. Operational reliability.

Atlas/Centaur (last 36 flights)	94%
Titan/Centaur (six flights)	100%
Centaur stage (last 40 trials)	100%

WHAT IS SUPPLIED FOR THE PAYLOAD?

The Atlas/Centaur provides general space and services for each of the spacecraft it launches. Unique requirements are provided on a mission-by-mission basis, but these unique requirements usually result in only minor modifications.

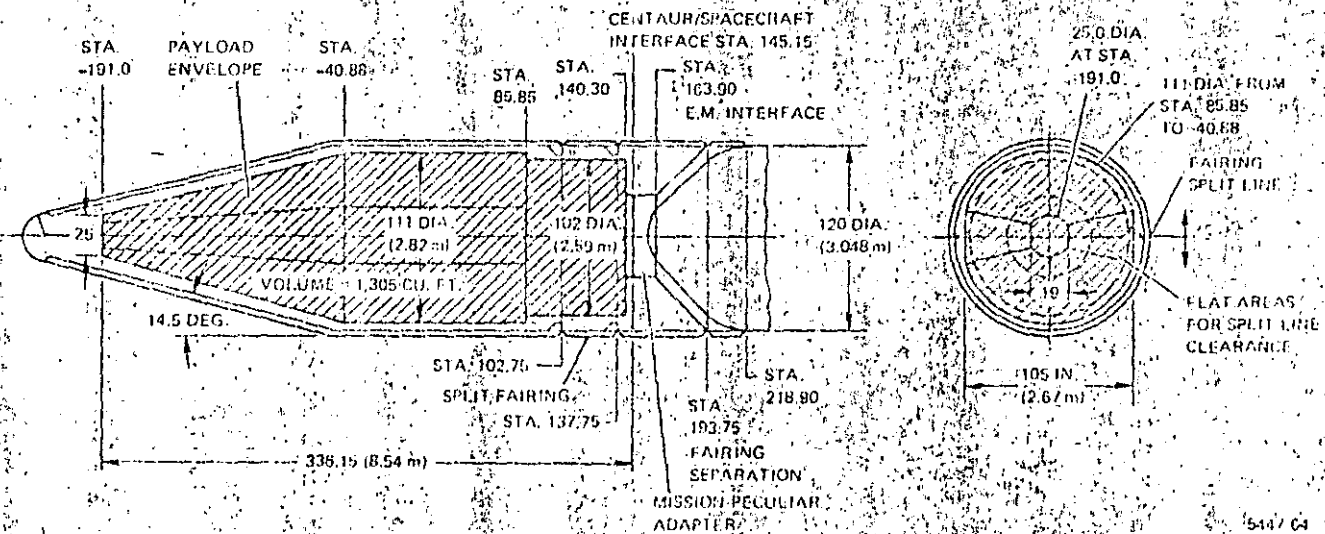


Figure 9. Centaur nose fairing useable space.

Figure 9 shows the space available within the Centaur nose fairing that is usable by a spacecraft. Usually payload dynamic analyses are performed in order to explicitly define this envelope for a specific application. Access doors are also provided for unique items.

For past payloads, Convair has provided structural adapters for mounting spacecraft to the Centaur forward equipment module. Normally, the spacecraft provides its own separation plane above the equipment module since there is no standard separation device designed for the module. Figure 10 shows the size and shape of these adapters.

Electrical and signal interfaces to each spacecraft are normally provided as shown in Figure 11. These standard services are usually adequate for most spacecraft but we have provided more, or less, in the past and the unique requirements of a particular spacecraft are usually easy to provide. We also have available, remote multiplexer units to provide for some spacecraft telemetry during ascent.

WHAT DOES THE SPACECRAFT HAVE TO ENDURE?

Many people say that the space environment is more benign than the things the spacecraft has to endure prior to launch and during its ascent. This is probably true, but if they are well known, then they can be accommodated. The pad environment and ascent conditions for Atlas/Centaur have varied only slightly over the last decade.

Thermal Conditions

On the launch stand a payload gas conditioning system provides dry air or gaseous nitrogen to the spacecraft at the required temperature, dew point, and flow rate. The flow paths are shown in Figure 12.

During the ascent the internal temperature of the fairing is very stable (Figure 13). The jettison point for the fairing is calculated during ascent and is usually set by performance requirements combined with spacecraft allowables for dynamic pressure. The pressure profile within the fairing during this same period is shown in Figure 14.

Structural Conditions

Figure 15 shows the axial load factors for a 5200-lb payload during the ascent portion of the Atlas/Centaur flight. In addi-

vehicle begins its launch phase when all booster engines are ignited and liftoff occurs (Figure 7).

FLIGHT PROFILE

At approximately 2.5 minutes into flight, the booster section is jettisoned and the sustainer phase continues until Atlas propellants are depleted. When Centaur engines are ignited and the nose fairing is jettisoned, the vehicle continues on to a parking orbit phase of variable length depending on the payload. The Centaur engines burn again to inject the payload into a geosynchronous transfer orbit, and the payload is separated. Circularization of the orbit is achieved by the use of an apogee motor on the payload.

PAYLOAD CAPABILITY

Figure 8 presents the synchronous transfer performance capability for the Atlas/Centaur vehicles now in production. Note that the transfer orbit inclination has a significant effect on the attainable weight. Those conditions noted on the figure are critical "ground rules" utilized to develop the curve and are shown as examples of some of the important parameters.

BUT WILL IT MAKE IT?

Atlas/Centaur reliability cannot claim a "certainty" level comparable to "death and taxes," but its success record is impressive. Table 2 shows that launching on an Atlas/Centaur

Figure 6. Current Centaur fairing (for Inmarsat IV).

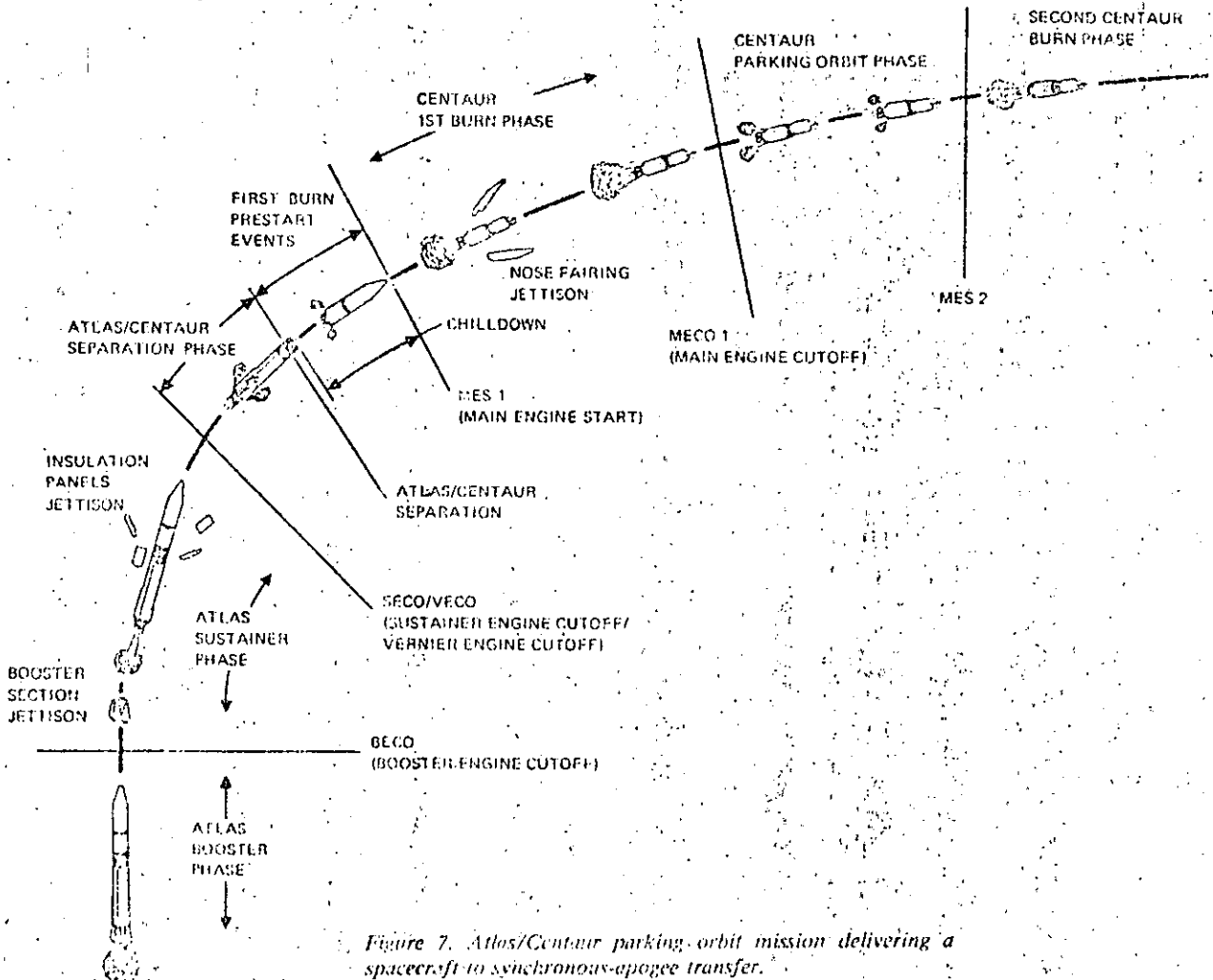


Figure 7. Atlas/Centaur parking orbit mission delivering a spacecraft to synchronous-apogee transfer.

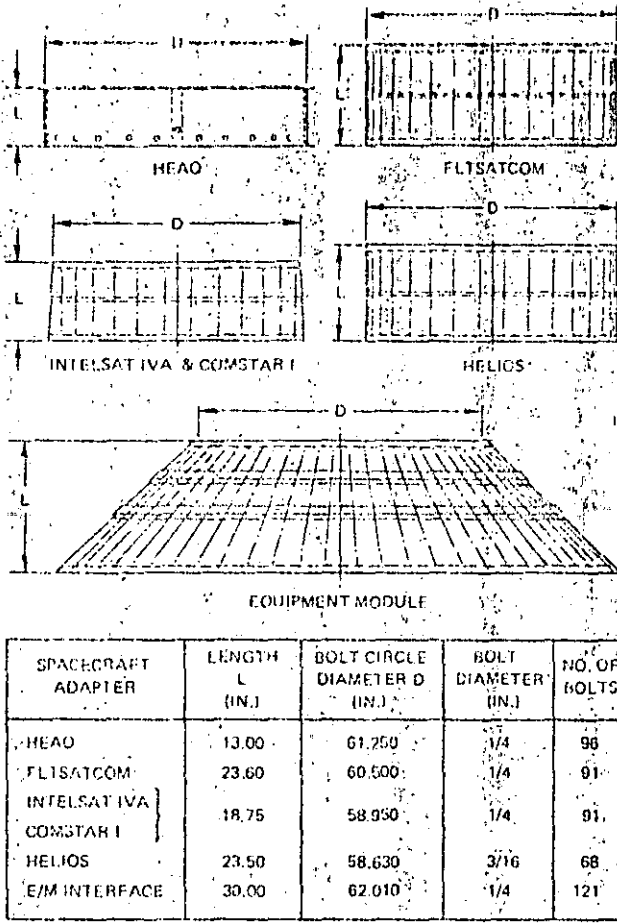


Figure 10. Equipment module interface.

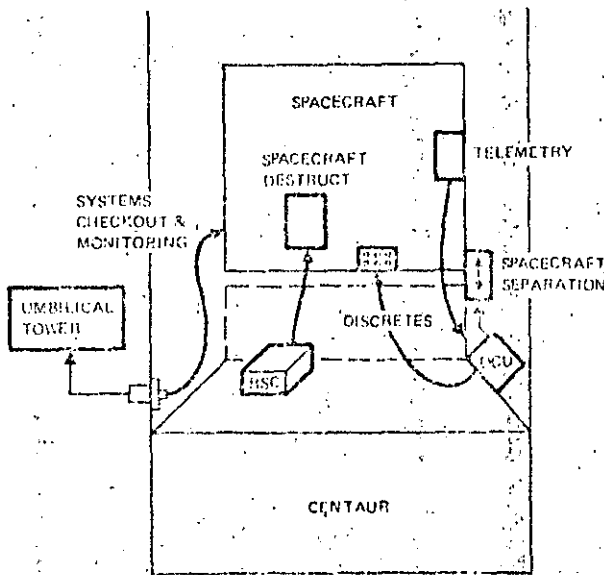


Figure 11. Typical electrical interfaces.

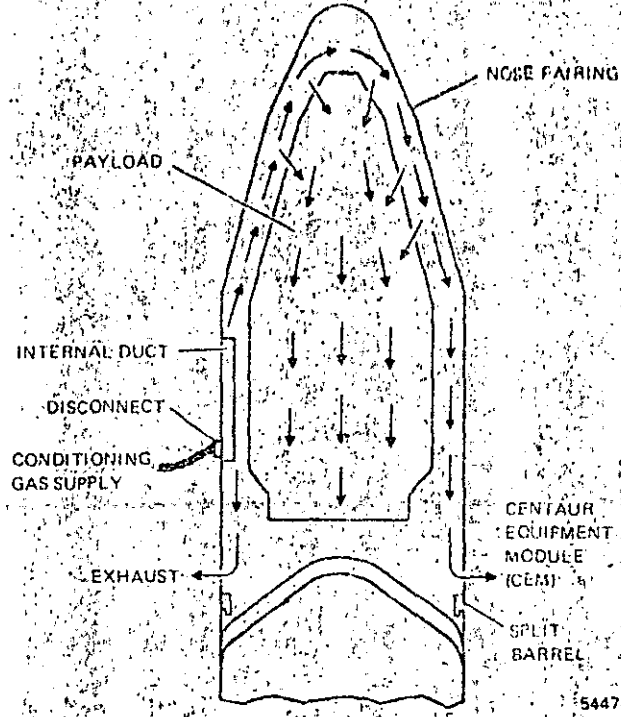


Figure 12. Payload gas conditioning system.

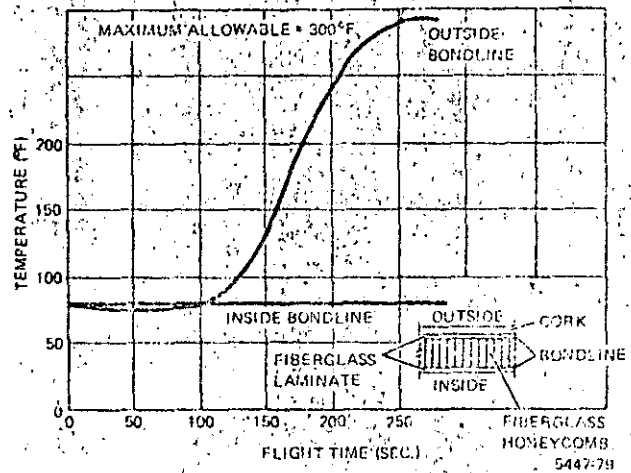


Figure 13. Fairing maximum bondline/temperature predictions (conical portion).

tion to these "steady state" accelerations, various transients apply equivalent accelerations of 1-2 g to the center of gravity of the spacecraft both laterally and longitudinally. Actual values are very sensitive to individual payload design with some tendency to decrease as payload weight increases.

Dynamic loadings on the spacecraft during ascent are a combination of vibration, acoustics and shock. Figure 16 shows a very general test level which would vary for different spacecraft. Each spacecraft is usually individually analyzed to determine its peculiar characteristics.

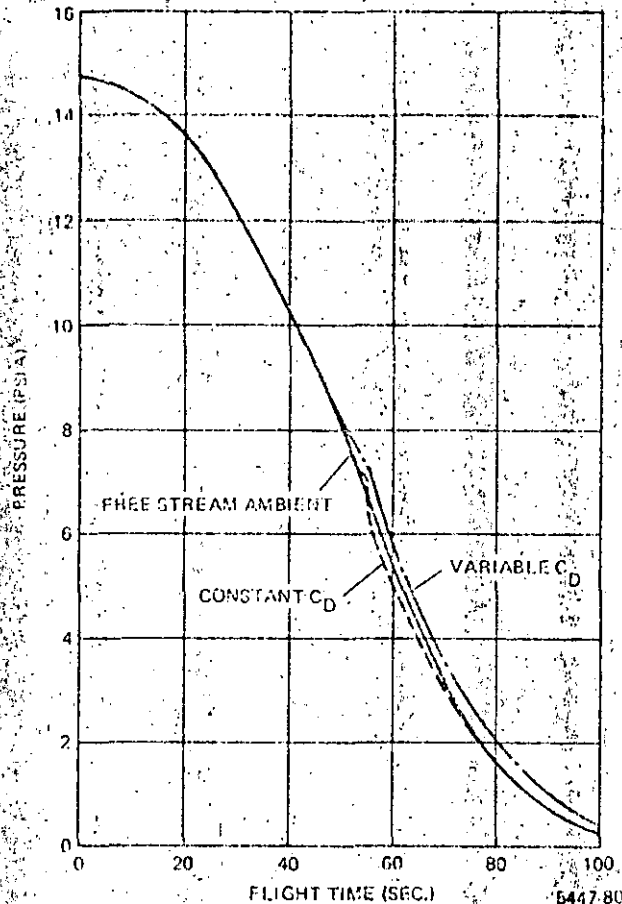


Figure 14. Typical fairing pressures.

Peaks of acoustic noise occur at launch and in the transonic portion of ascent and payload components should be capable of functioning during one minute of exposure to the acoustic spectrum portrayed in Figure 17.

Although shock events occur upon jettison of nose fairing and insulation panels due to pyrotechnic devices, the major payload shocks are normally encountered during the self-generated separation event.

WHAT DOES THE PAYLOAD GET FOR ITS TROUBLE?

One of the hallmarks of the Centaur vehicle is accuracy. The combination of the highly accurate inertial guidance system with flexible guidance software has enabled the Centaur to achieve precise injection conditions for a complete spectrum of missions, both interplanetary and earth-centered. Figures 18 and 19 demonstrate that Centaur not only meets the mission requirements but exceeds them by a substantial margin.

SUMMARY

The Atlas and Centaur vehicles have adapted and evolved over the years to supply a portion of the launch capability needed by the world's spacecraft community (Figure 20). This

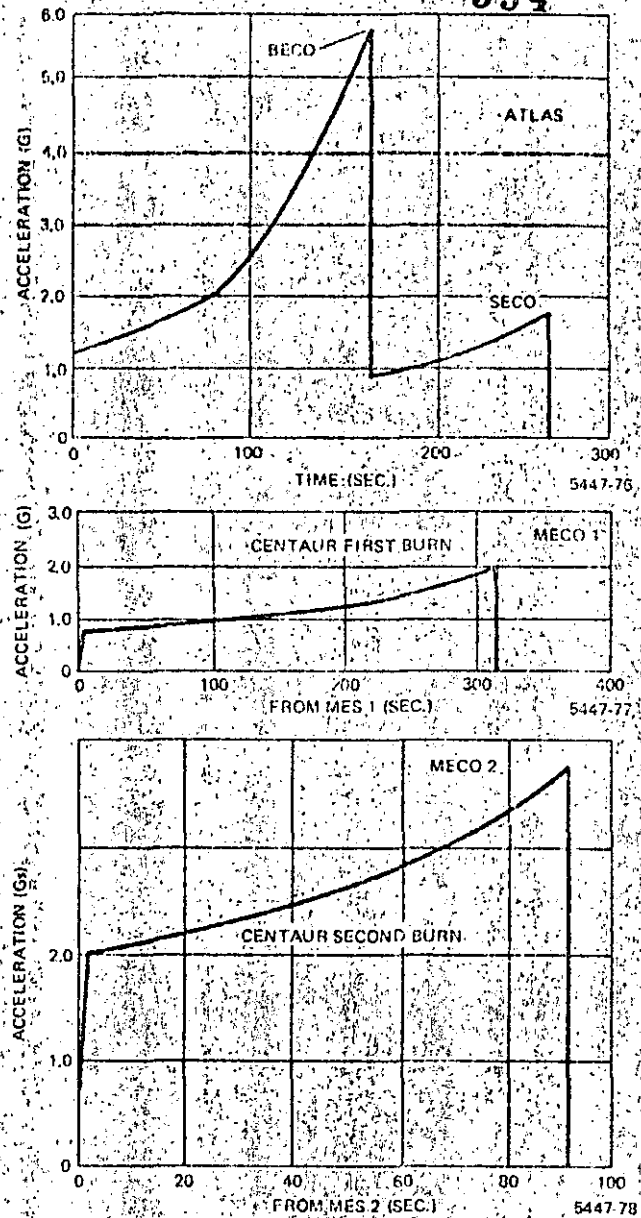


Figure 15. Axial load factors for Atlas/Centaur flight (5,200-lb payload).

process has not been without some temporary setbacks even though every change was critically evaluated for what its effect would be on the launch reliability of the vehicle. Even today, under the direction of the NASA Lewis Research Center, the capability of the Atlas/Centaur is being expanded to meet current requirements and will, in the future, provide the same high-performance, reliable launch services that have enabled it to be today — 27 years and counting.

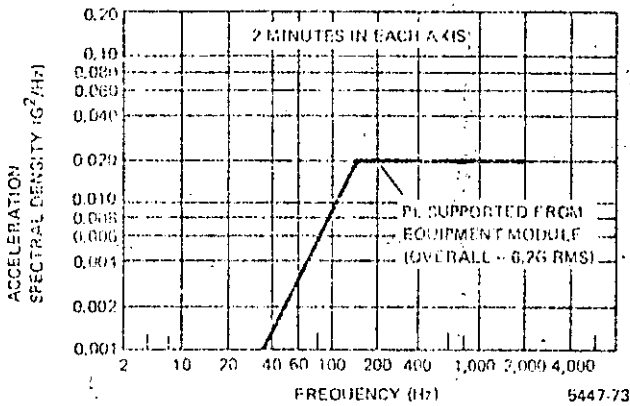
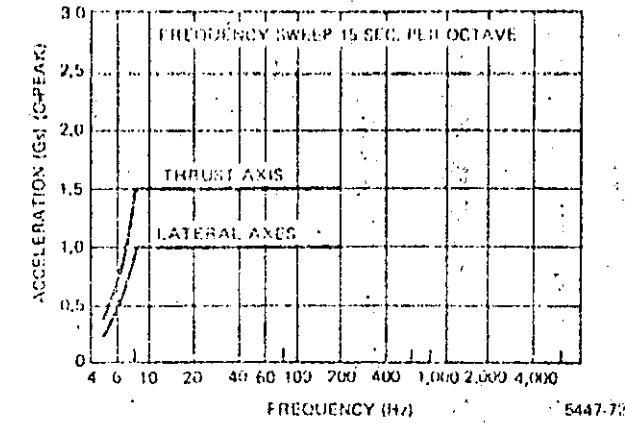


Figure 16. Recommended sinusoidal vibration environment and expected random vibration spectrum.

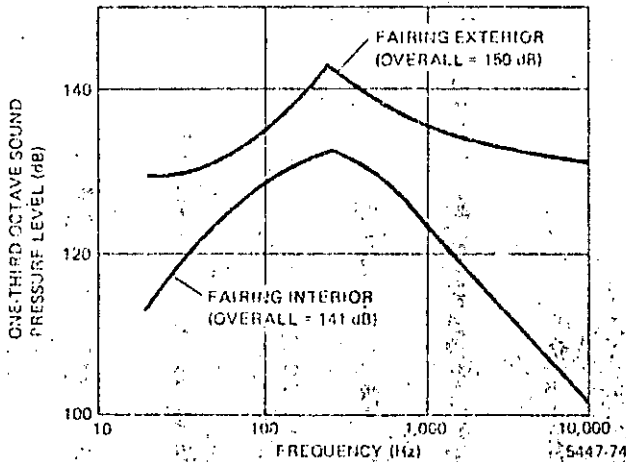


Figure 17. Expected acoustic environment.

	Transfer orbit (Centaur 2nd burn)		Final Orbit (Centaur 3rd burn)
	Flight Data	Guidance System 3a	Guidance System 3b
Perigee (nmi)	0.83	1.3	—
Apogee (nmi)	34.1	63.3	—
Apogee Minus Perigee (nmi)	—	—	306
Inclination (deg)	0.000	0.022	0.29
Period (min)	1.21	2.25	11

* AC-54 Intelsat
* Titan/Centaur

Figure 18. Typical accuracy for synchronous orbit.

	Mission Requirement	Flight Data	Guidance System 3a
Relative Node (deg)	0.5	0.05	0.14
Circularity (nmi)	5.0	2.8	3.98
Inclination (deg)	0.1	0.003	0.007

Figure 19. Typical accuracy for near-earth orbit (HEAOA 290 nmi data). Launch mode: direct ascent.

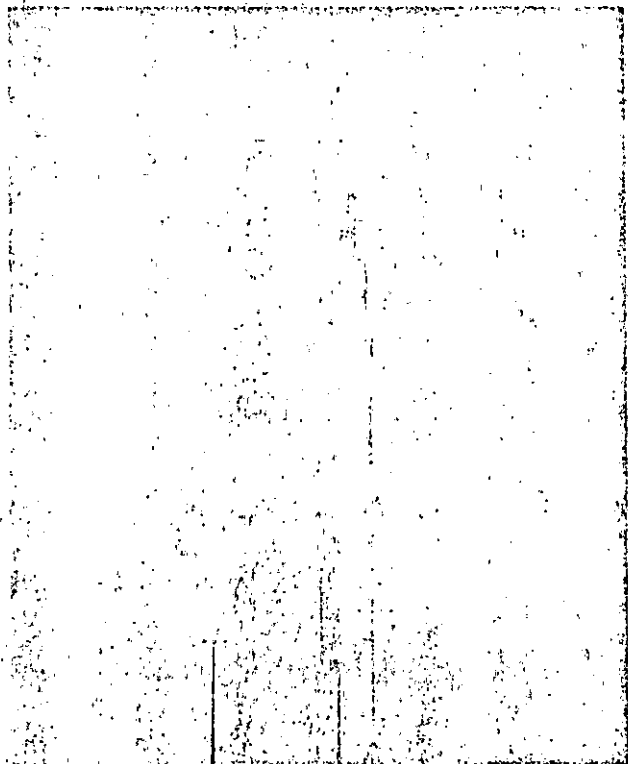


Figure 20. Communication satellite launch by Atlas/Centaur.

SPACE TRANSPORTATION SYSTEMS UTILIZATION

CHESTER M. LEE
DIRECTOR, STS UTILIZATION

NASA HEADQUARTERS

ABSTRACT

It is planned that the Space Transportation System (STS) will become operational in late 1962 after the successful completion of four test flights. To date, two flights were successful with a third scheduled for late March 1962.

The successful utilization of the STS will depend upon reducing costs and the price of sending cargo and ultimately people into space. As this begins to take effect, more and more flights will occur. The Space Shuttle can be reflown up to 100 times and unlike the expendable launch vehicles, offers a tremendous opportunity for developing a cost reduction in space utilization.

This presentation will focus on the Space Shuttle system, its components and what the mission profile and launch sequence will entail. Also included will be the types of payloads carried on the Shuttle, the upper stages, a discussion of the current NASA Space Shuttle manifest and a preview of the Ariane competition.

CHART 1 - A general overview of the Space Transportation System which includes the Space Shuttle, Spacelab, TUS, SSUS-A, and SSUS-D configurations.

CHART 2 - The general dimensions and performance levels of the Space Shuttle reveal its potential capabilities.

SPACE SHUTTLE SYSTEM

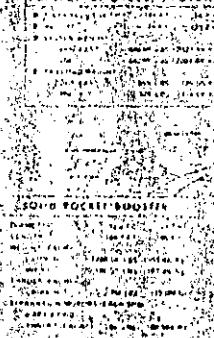


CHART 3 - The mission profile, from payload integration, liftoff, orbital operations, re-entry and landing.

CHART 4 - An overview of the NASA Kennedy Space Center Shuttle facilities. Includes the facilities which will be used to checkout, integrate, and launch the payloads on the Shuttle.

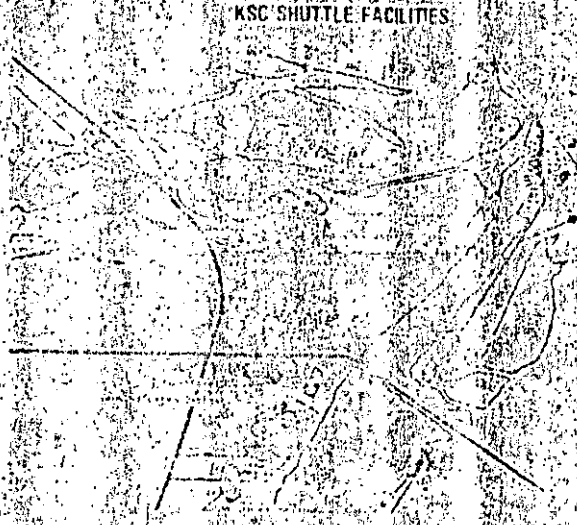


CHART 6 - A listing of the Space Transportation Products and Services.

SPACE TRANSPORTATION PRODUCTS AND SERVICES

- LAUNCH AND ORBIT SERVICES
- PAYLOAD HANDLING AND CHECKOUT
- PAYLOAD OPERATORS SUPPORT
- CREW TRAINING
- SPARES AND LOGISTICS
- EXPENDABLE LAUNCH VEHICLES
- SHUTTLE EXPENDABLES
- OPERATIONAL UPPER STAGES
- SPACELAB AND SUPPORT EQUIPMENT
- RATE FACILITIES

CHART 5 - The Shuttle mission priorities which specify first-come, first-serve.

MISSION PRIORITIES

- GENERAL POLICY
 - TO ACCOMMODATE USER REQUIREMENTS AS CLOSE AS POSSIBLE ON A FIRST-COME, FIRST-SERVED BASIS
- IN THE EVENT OF CONFLICTING REQUIREMENTS, THE PRIORITIES TO BE FOLLOWED ARE:
 - SPACE PROGRAMS (DEFENSE) URGENT SIS SUPPLY TO MAINTAIN NATIONAL SECURITY MISSION CAPABILITIES
 - COMMERCIAL & FOREIGN
 - NASA PAYLOADS

CHART 7 - A pictorial view of the Space Shuttle manifest.



CHART 8 - A listing of the domestic and the foreign payloads booked on the Shuttle and Expendable Launch Vehicles (ELV).

OFFICE OF SPACE TRANSPORTATION OPERATIONS SHUTTLE/ELV REIMBURSABLE USERS (EXCEPT OTHER U.S. GOVERNMENT AND DOD)									
AT&T COMM. LINE	4	2	2	WEST GERMANY (BMFT)	2	2			
ETE SATELLITE CORP.	4	2	2	INDONESIA	2	2			
HUGHES COMM. INC.	8	8		TELCELAT CANADA	2	1	8		
HUGHES COMM. SERVICES, INC.	8	8		INDIA	2	2			
SOUTHERN PACIFIC COMM.	2	2	2	INDONESIA	2	2			
SATELLITE BUSINESS SYSTEMS	2	2		ASAP SATELLITE COMM. INC.	2	2			
SPACECOM	4	4		AUSTRALIA	2	2			
SATELLITE TELEVISION CORP.	6	6		COLOMBIA	2	2			
COMSAT CENTRAL CORP.	6	6		ITALY	2	2			
SEA AMERICAN CORP., INC.	10	8	10	JAPAN (SHARED SPACEFLIGHT)	2	2			
WESTERN UNION TELEGRAPH CO.	4	2	1	UNITED KINGDOM	2	2			
USA SATELLITE SYSTEMS	1	1		KATO	2	2			
AMERICAN SATELLITE CO.	3	3		RAION-TELE-LUXEMBOURG	2	2			
				INTELSAT	20	5	14		
				COES (SHARED SPACEFLIGHT)	1	1			
				BRAZIL	2	2			
				ENGLISH AEROSPACE	1	1			
TOTALS	62	22	32	TOTALS	58	9	42	7	

CHART 10 - The U.S./Foreign Geosynchronous Communications Traffic projected to the year 2000 and the increasing number of transponders on-orbit in the out years.

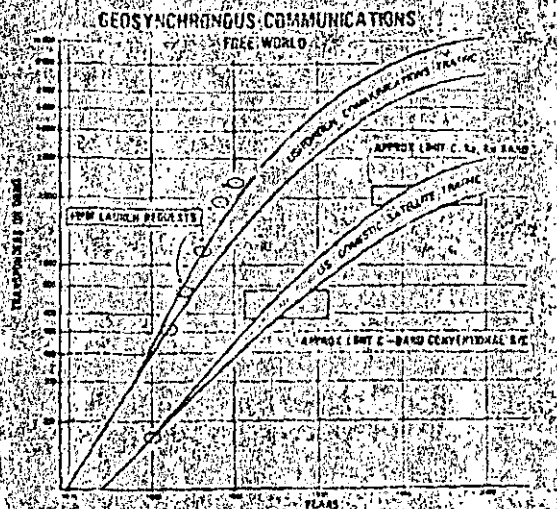


CHART 9 - A cost comparison between the STS and the ELV.

ELV vs STS COST COMPARISON

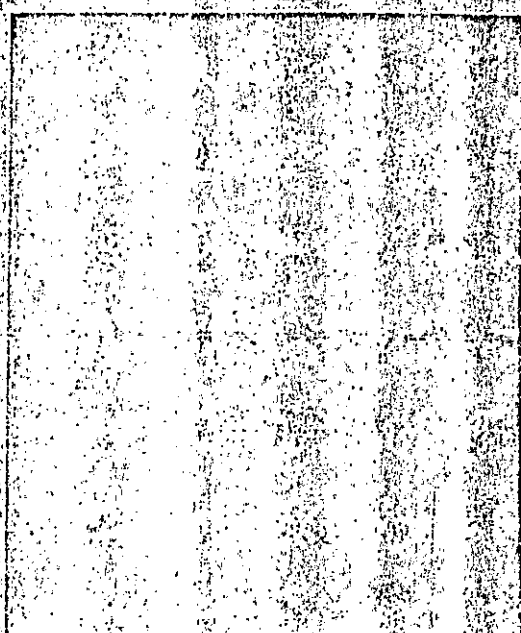
- **CURRENT ASSESSMENT**
 - CURRENT PRICE (\$18M (75\$)) IS COMPETITIVE WITH ELV'S. SHARED SHUTTLE PRICE EQUALS APPROXIMATELY:
 - 50% DELTA PRICE
 - 60% ATLAS/CENTAUUR PRICE IF P/L SHUTTLE OPTIMIZED
 - 65% ATLAS/CENTAUUR IF P/L DUAL COMPATIBLE
 - 85% TITAN 34 D PRICE OF FOUR TITAN LAUNCHES PER YEAR
 - 50% TITAN 34 D PRICE OF EIGHT TITAN LAUNCHES PER YEAR
- **FUTURE PLANS**
 - PRICE FOR LAUNCH IN FY 1988 EXPECTED IN \$31-\$35M (75\$) RANGE IF PRICE IS \$27M (75\$) SHARED SHUTTLE PRICE EQUALS APPROXIMATELY:
 - 70% DELTA PRICE
 - 80% ATLAS/CENTAUUR PRICE IF P/L SHUTTLE OPTIMIZED
 - 100% ATLAS/CENTAUUR PRICE IF P/L DUAL COMPATIBLE
 - 85% TITAN 34 D PRICE OF FOUR TITAN LAUNCHES PER YEAR
 - 55% TITAN 34 D PRICE OF TWO TITAN LAUNCHES PER YEAR

CHART 11 - Provides a description of Geostationary Platform.

EXPERIMENTAL GEOSTATIONARY PLATFORM

DESCRIPTION/FUNCTION:	To demonstrate technologies needed for operational geostationary platform in the 1990s, and to permit test of new communications technologies. Such platforms will be required for extension of earth's spectrum resource, and for scientific experiments in radio earth observation, remote information services, and national security.
NASA CENTER:	MSFC
CONTRACTOR:	General Dynamics
FUNDING:	1981-2000 (plus 100 from QSTAR) 1981-2000 1982-2000
STATUS:	Final Step under study
PROPOSED NEW SIARI:	1980
PROPOSED FIR FIGHT:	1981
RELATION TO OTHER PROGRAMS:	Supported by large space structure/vehicle studies.

CHART 12 - Geostationary Platform.



CHARTS 14 & 15 - A description of NASA Small Self-Contained Payloads Program used on the Shuttle.

SMALL SELF-CONTAINED PAYLOADS (GETAWAY SPECIALS)

DEFINITION PAYLOADS THAT REQUIRE MINIMUM SERVICES PROVIDED BY SMALL AVAILABLE DUNGS FROM 200 POUNDS TO 3000 POUNDS

QUALIFICATION SCIENTIFIC RESEARCH AND DEVELOPMENT

PRICE BETWEEN \$3,000 AND \$10,000 DEPENDING ON SIZE AND WEIGHT

CATEGORIES INDUSTRIAL PHARMACEUTICAL RESEARCH, MATERIALS TESTING AND PROCESSING
 EDUCATIONAL PURE AND APPLIED RESEARCH
 INDIVIDUAL PRIVATE CITIZENS TESTING INNOVATIONS AND RESEARCH IDEAS
 GOVERNMENTAL SCIENTIFIC EXPERIMENTS BY ALL AGENCIES OF FEDERAL, STATE AND OTHER GOVERNMENTS

RESERVATION SUBMIT \$500 EARNEST MONEY PAYMENT TO DIRECTOR, FINANCIAL MANAGEMENT CODE: BF-6 NASA HEADQUARTERS WASHINGTON, D.C. 20546

INFORMATION CONTACT MS. DONNA MULLER AT NASA HEADQUARTERS (202) 755-2427

CHART 13 - A summary of the NASA commercial effort involving Materials Processing in Space.

MATERIALS PROCESSING IN SPACE (MPS) COMMERCIAL MPS PARTICIPANTS

- **JOINT ENDEAVOR AGREEMENT**
 - PROVIDES FOR FLIGHT TIME ON STS - NO EXCHANGE OF FUNDS BY NASA
 - INDUSTRY PROVIDES THE COMMERCIAL PRODUCT IN LOW G ENVIRONMENT OF SPACE
 - MCDONNELL DOUGLAS ISSUED JANUARY 29, 1980
 - TESTS CONTAINING FLOW ELECTROPHORESIS APPARATUS TO DEVELOP COMMERCIALY USEFUL POLYMER MEMBRANE MATERIALS
 - STI CORPORATION ISSUED JANUARY 20, 1982
 - EXT. MARK BARBER AND OTHERS SALE TO UNIVERSITY AND INDUSTRIAL RESEARCHERS
 - MICROGRAVITY RESEARCH ASSOCIATES, INC. (PROPOSED)
 - USE HIGH GRAVITY AND FREE CRYSTALS FOR ELECTRONIC AND COMPUTER APPLICATIONS
- **TECHNICAL EXCHANGE AGREEMENT**
 - PROVIDES FOR SHORT DURATION LOW G TIME ON DROP TUBES/DROP TOWER AND KC-135 - NO EXCHANGE OF FUNDS
 - DEAL AND COMPANY ISSUED JUNE 29, 1981
 - EXP. DURATION 18 MONTHS TO 18 MONTHS PROCESS
 - DUPONT ISSUED JANUARY 27, 1982
 - FUTURE TESTS AND EXPERIMENTS OF VARIOUS AGENTS
 - AECB RESEARCH AND DEVELOPMENT CENTER, INC. ISSUED JANUARY 29, 1982
 - RESEARCH TESTS TO BE CONDUCTED AT 104 G
- **INDUSTRIAL CUBIC INVESTIGATOR**
 - NASA PROVIDES FLIGHT SUPPORT AND TESTS/PRINCIPAL INVESTIGATOR
 - COLLABORATE IN RESEARCH AREA OF MUTUAL INTEREST - NO EXCHANGE OF FUNDS
 - TRW, CLEVELAND ISSUED APRIL 1980
 - UNIVERSITY OF CALIFORNIA, SAN DIEGO AT 104 G

OFFICE OF SPACE TRANSPORTATION OPERATIONS	
SMALL SELF-CONTAINED PAYLOADS	
RESERVATIONS	TOTAL = 322
INDUSTRIAL	158
EDUCATIONAL	85
INDIVIDUAL	51
U.S. GOVERNMENT	28
MILESTONES	
• FIRST LSA SIGNING	6/81
• PROOF FLIGHT CANNISTERS	STS-3 3/82
• FIRST GAS PAYLOAD	STS-4 5/82
• UP TO 5 GAS PAYLOADS	STS-5 11/82

THE ARIANE CHALLENGE

- **ARIANESPACE MARKETING SERVICES AGGRESSIVELY**
 - GERMANY ARIANESPACE, EADS AND AIRBUS MAIN CONTRACT REPRESENTATIVE
 - BUNNAG HAS MADE AGREEMENT TO BUILD AND MARKET PLATFORMS FOR ARIANESPACE, EADS AND AIRBUS TO BE DEVELOPED BY ARIANESPACE, EADS AND AIRBUS
 - BUNNAG HAS MADE AGREEMENT TO BUILD AND MARKET PLATFORMS FOR ARIANESPACE, EADS AND AIRBUS
 - 22% TO SHARE IN MONTHS FROM TO 1997
 - 10% TO SHARE IN PAYMENT SCHEDULE STARTING SIX MONTHS AFTER LAUNCH AT 1997
- **USERS THAT ORDER THE ARIANE LAUNCH SERVICES RATHER THAN NASA'S**

USER	NUMBER OF PAYLOADS
● WELLSAT	2
● SOUTHERN PACIFIC	1 (AS FAR AS POSSIBLE)
- **USERS DOUBLE BOOKED WITH ARIANE AND NASA**

USER	NUMBER OF PAYLOADS
● ARASAT	2
● COLUMBIA	2
● WELLSAT	1
● SCA AMERICAN	1
● AEROSPACIA	2
● REDOUBLE PAYMENTS	1
● SATELLITE TELEVISION CORP	1
● EIRASAT	2

ARIANE
EUROPE'S EXPENDABLE LAUNCHER

DR. KLAUS ISERLAND
Deputy Director General

ARIANESPACE

ABSTRACT

ARIANE as a competitive expendable launcher has received recently growing world-wide attention and raised much interest in the United States. This paper is aimed at exposing ARIANE's features and present status, its commercialization and finally its order book and future prospects.

INTRODUCTION

With the ARIANE 1 to ARIANE 4 family of expendable launchers, Europe is now offering up to far in the 90's a space transportation system which, although expendable, has received bookings from different parts of the world up to 1986 so far; and which appears to remain competitive at least during this decade. This success of an expendable launcher in our days is certainly due to its low-risk concept, its performances matching well the market needs, its long-term availability and the industrial approach chosen for its marketing and sales.

TEXT

Europe has engaged in a long term effort to assure the availability of a ballistic space transportation system by developing the ARIANE family (fig.1). The development of ARIANE 1 with 1 780 kg in GTO is now achieved, modifications are presently introduced and solid strap-on boosters developed to obtain in 1983 performances of 2 175 kg GTO for ARIANE 2 and 2 580 kg for ARIANE 3.

Also, just at the beginning of 1982 the European nations decided to go ahead with the ARIANE 4 program in order to have available in 1986 a vehicle capable to boost up to 4 200 kg in GTO.

The concept

The concept of ARIANE was deliberately aimed at using well proven technologies, in particular in the two first stages (both stages use the same "VIKING" engine which is the latest of an engine family developed for the 2nd stage of the EUROPA-2 launcher and the successful French "DIAMANT" series), while still achieving high performance through cryogenic propulsion in the 3rd stage (with a prudent approach by choosing low chamber pressure) and high injection accuracy through a very precise inertial guidance. This may explain why already the first test flight was completely successful, an achievement which, to our knowledge, has only one precedent: the US SATURN family of launchers.

In the same philosophy, the continuous increase in performance from ARIANE 1 to ARIANE 4 is achieved by introducing successively conservative improvements with now major technological steps.

Thus ARIANE 2 differs from ARIANE 1 only by a thrust chamber increase of less than 10 % and propellant increase in the 3rd stage by 25 %. ARIANE 3 is identical to ARIANE 2; merely 2 solid strap-on boosters are added. The decision to fly in ARIANE 2 or ARIANE 3 configuration can be taken as late as 8 to 6 months before launch. ARIANE 4 uses the same 2nd and 3rd stage as ARIANE 3, the first stage is stretched to take some 50 % more propellants, while using the same engines as ARIANE 3. Different combinations of solid and liquid strap-on boosters can be used to match the actual payload, the solid ones being those used for ARIANE 3, the liquid ones using the same "VIKING" engines as the 1st and 2nd stage.

Of course, the payload compartment - i.e. the fairings - is augmented in proportion to the increasing performance.

Meeting the market

To offer space transportation responds today to a market need. Fig. 2 shows geosynchronous orbit traffic of the GEO age including contracted or reserved launchings until 1986. The traffic growth is striking. However, the market does not appear to us unbalanced as sufficient transportation capacity seems to be available through the existence of the US ballistic launchers, the STS and the European ARIANE.

Europe has realized the importance of this market and has therefore tried to find the best suited response to growing industrial and commercial activities by creating the first space transportation company in the world, ARIANESPACE, in March 1980. This company with a capital of 120 million FF has been created by 36 European aerospace companies, 13 European banks and the French National Space Agency C.N.E.S. It has been entrusted with the worldwide marketing of the ARIANE launch services and assures with its own resources continuous production of the vehicle and execution of launchings and launch related operations.

The role of ARIANESPACE

This company houses the managerial, marketing and engineering skills to operate the ARIANE launch vehicle. All follow-on development of ARIANE is however conducted under the responsibility of ESA and executed by the French National Space Agency. Upon completion, ARIANESPACE undertakes to operate all demonstrated systems.

ARIANESPACE is based in Evry, in the Southern suburbs of Paris, in France.

All of the 36 industrial shareholders of ARIANESPACE are its suppliers. The French National Space Agency holds 34%. Main suppliers are presently:

AEROSPATIALE	* 1st, 3rd stage, system integration
ERNO	* 2nd stage
MATRA	* vehicle equipment bay
SEP	* engines of 1st, 2nd and 3rd stage
CONTRAVES	* fairings
DIFEZA E SPAZIO	* solid boosters.

They hold 30% of the shares, the remainder being held by the subcontractors and the banks.

France in particular followed by Germany have most of the interest in this venture.

It is our impression that the commercial initiative to create ARIANESPACE has been well received.

The order book grew from 1.4 billion FF in 1980 to 3 billion at the end of 1981. A total of 19 vehicles, including the 4 flight test vehicles, and 6 launchers of the first operational series have been produced or are presently under production, 9 of which ordered by ARIANESPACE, and longlead items for 5 more are ordered. As entrepreneurship in the market spreads, commercial entities generally respond more flexibly and adjust better to market needs. We also believe that the commercial community benefits from the fact that the monopolistic market situation of space transport has been replaced by a competitive one.

The launch service offered

ARIANESPACE offers to its clients dedicated and shared launchings. In a dedicated launch, generally one spacecraft uses the entire performance of the ARIANE. The best example here are the launchings of the INTELSAT V and VA.

In a shared launch two spacecraft of the Thor-Delta-PAM-D or STS-SSUSD class are put on one launch vehicle using a special double launch adaptor called SYLDA (Système de Lancement Double Ariane). This double launch mode in particular makes the ARIANE launch extremely cost-effective for a PAM-D type spacecraft. Fig. 3 shows launch configurations for shared launchings.

The ARIANE 4 shall offer larger payload capability and volume to spacecraft. Fig. 4 depicts the volume available for shared launchings as compared to the presently available volume size of ARIANE 3, DELTA or STS-SSUSD. ARIANE 4 shall not only allow shared launchings of PAM-D type spacecraft, but also shared launchings of spacecraft of 2'000 kg or more together with PAM-D type spacecraft.

ARIANE launchings take place in French Guiana, which is an overseas department of France. The launch base has a privileged location about 5 degrees north of Equator. Since its establishment in 1968, it has become one of the most modern launch sites in the world and offers all buildings and equipment necessary to safely and expeditiously prepare spacecraft for launch. Here again, Europe has engaged into a long term effort as a second launch pad is presently under construction and work to extend the available spacecraft preparation and check-out buildings has started. The second pad shall be in service in 1985 and by that allow to increase launching frequency to 8 and later to 10 per year.

ARIANESPACE launch services can be obtained by first reserving a launch slot against payment of US \$ 100 000 per reservation. A contract for launch services should typically be signed 3 years before launch. It is also possible to buy a paying option for a duration of 12 months valid until 2 years before launch.

It is our understanding that insurances against launch failure are available on the market at rates comparable to rates for other expendable launch vehicles. Against third party liability, ARIANESPACE takes out unlimited insurance for its clients for three years.

Commercial use of ARIANE is best reflected in the present status of orders and reservations of this vehicle that shows continuous and increasing use of the system. Flight qualification of this vehicle has been achieved by 4 test flights called L01 through L04.

A special feature of this period of test flights that extended over 2 years was that not only test and measurement equipment has been flown, but also real spacecraft and this from the second test flight onwards.

Therefore, we have not only acquired knowledge of the launch vehicle itself but also qualified all service related buildings and operations and have also launched two spacecraft at once on L03 followed by a commercial spacecraft (MARECS-A) on L04.

Now the initial phase of operational exploitation of the ARIANE launch vehicle has started with the flight L5 in May 1982.

The order book

Review of the order and reservation list (fig. 5) allows the following conclusions:

1) The launch sequence will be gradually increased from 4 in 1982 to 5 in 1983 and 1984. It is presently planned a number of up to 8 launchings in 1985. This will be made possible through the 2nd launch pad.

2) 1982 and 1983 are fully booked. However, two flight opportunities on L11 and L12 could be made available. Towards the end of 1984, a fifth launching is entirely available.

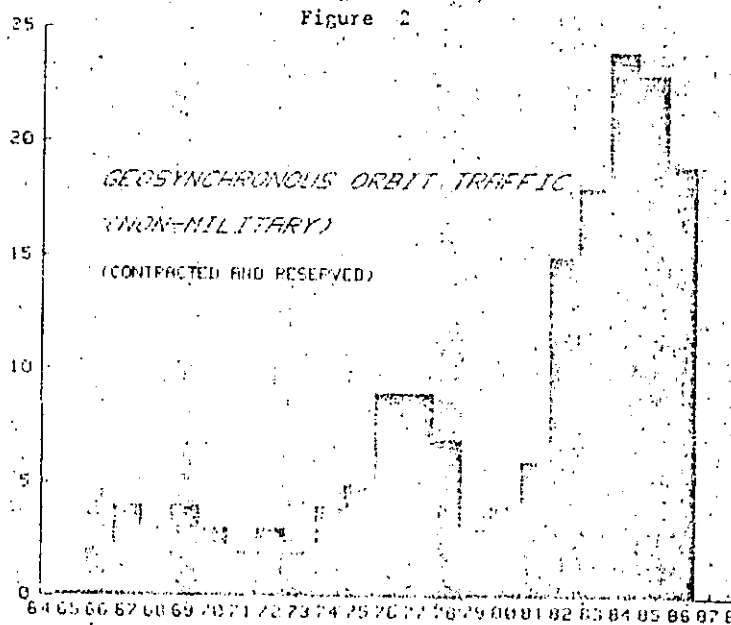
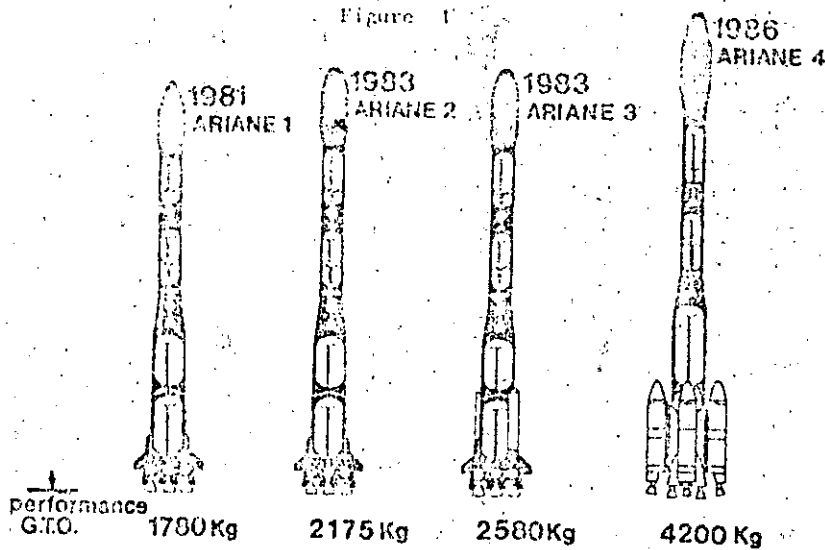
3) All types of commercial spacecraft presently built in either Europe or US will be flown at least once on ARIANE.

4) The maiden flight of ARIANE 4 is scheduled for late 1985.

5) Export is vital for ARIANE, the portion of export missions to European missions approaches 50%. We assume that this relation will be maintained.

The success of ARIANE has created a competitive market situation beneficial to the customer. As competition has been increased, it is the most important driver towards success. In more business, we are sure that we have managed into a period of growth. Therefore,

Europe expects extensive use of this transportation system through a long period of operations and understands it to be competitive with other available expendable systems or with the Space Shuttle.



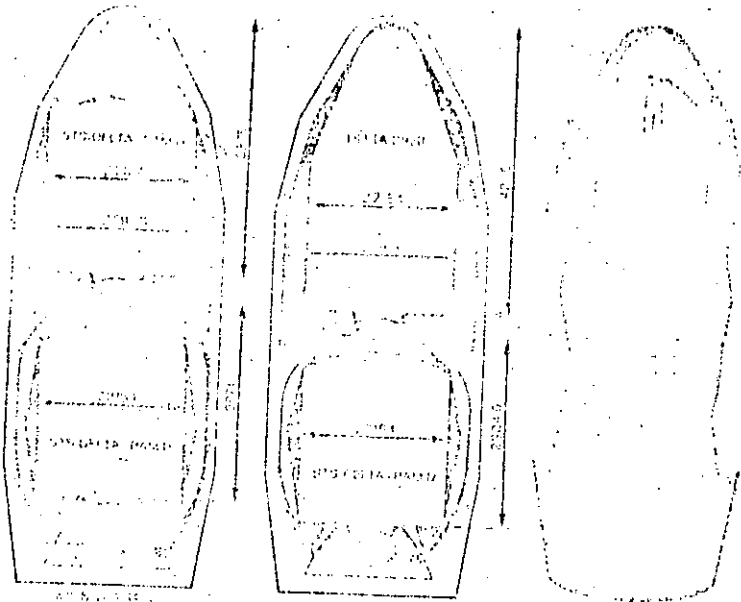
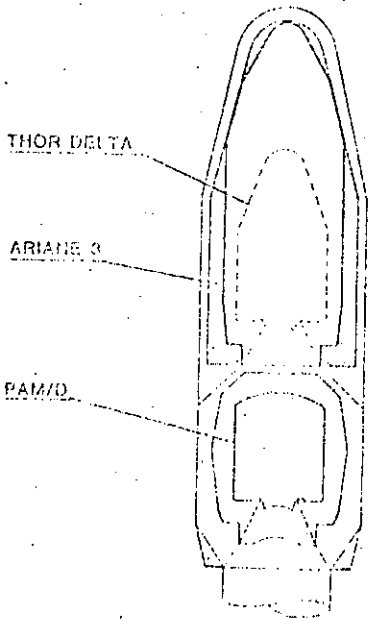


Figure 4

ARIANE 4

(Static envelope)



ARIANE 3

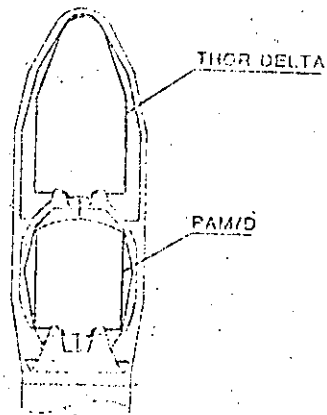


Figure 5

DGA/TC-KI/HC
4/02/82STATUS OF ORDERS AND
RESERVATIONS OF THE
ARIANE LAUNCHER

1980 - 1985

L01	AR.1	CAT	12/79
L02	AR.1	CAT + AMSAT + FIREWHEEL	05/80
L03 L04	AR.1 AR.1	CAT + METEOSAT + APPLE CAT + MARECS-A	06/81 12/81
L 5 L 6 L 7 L 8	AR.1 AR.1 AR.1 AR.1	MARECS-B + SIRIO-2 ECS-1 + AMSAT INTELSAT V F6 EXOSAT	04/82 07/82 10/82 12/82
L 9 L10 L11 L12 L13	AR.1 AR.1 AR.1 AR.2 AR.3	INTELSAT V F7 INTELSAT V F8 or ECS-2 ECS-2 or INTELSAT V F8 TELECOM-1A TELECOM-1B + WESTAR-VI	02/83 05/83 07/83 09/83 12/83
L14 L15 L16 L17 L18	AR.3 AR.3 AR.2 AR.3 AR.3	SPACENET-1 + ARABSAT-1 GSTAR-1 + (ECS-3) SPOT-1 + VIKING GSTAR-2 + SPACENET-2 (SATCOL-1) + ...	02/84 04/84 06/84 08/84 12/84
		INTELSAT VA F14 TV-SAT TDF 1 (AUSSAT 1) (SATCOL 2) GIOTTO INTELSAT VA F15 ARIANE 4/01 (STC) (AUSSAT 2)	1st half year 1985 2nd half year 1985
		Note : Second launch pad available from 1985 onwards	
		SPOT 2 L-SAT (CLT) (TELE-X) (INTELSAT VI) (TEL-SAT)	Year 1986

() = reservation

JAPAN'S EXPENDABLE LAUNCH VEHICLES

Takashi Matsuda, Masafumi Miyazawa
and Shinji Nio

National Space Development Agency of Japan

INTRODUCTION

The National Space Development Agency of Japan (NASDA) has been conducting the development and operation of a satellite launcher called N-rocket over the past ten years. This N series rocket, Japan's first liquid propellant booster, is a three stage vehicle capable of launching medium size applications satellites. The N launch vehicle program, from the basic N, called N-I vehicle, through the current N, called N-II vehicle, has been supported by the United States through government level agreements. Hardware and technology of the NASA Thor-Delta have been transferred and applied to both N-I and N-II vehicles.

The N-I rocket project started in 1970 and this launch vehicle became operational in 1975 when it successfully put an 85 kg Engineering Test Satellite into a planned orbit accurately in its first flight. Since then the N-I rocket has launched six satellites in total, with five successful flights and one malfunction connected with the mission failure.

Following the successful operation of the first generation of the N (N-I launch vehicle), the upgraded N-II vehicle has entered on the operational phase with two successful flights in 1981. Being capable of placing about 350 kg payload into geostationary orbit, this N-II rocket is the heaviest launcher at the present time in Japan to be used for launching various applications satellites over the coming several years. Figure 1 shows the lift-off scene of the first N-II launch which took place in February 1981.

To meet the need for launching large capacity applications satellites in near future as requested by Japan's satellite users, NASDA has been carrying out study and development work of a future rocket, called H-I launch vehicle with high performance capability. This new launch vehicle, with the estimated capability of placing about 550 kg payload into geostationary orbit, is expected to meet the need for heavier applications satellites requested from Japan's future users in the late 1980s through the 1990s.

This paper presents a brief description of N and H vehicles including configuration, subsystems and performance capability. The current launch schedule and mission summary are also presented.



Fig. 1 Lift-off of N-II Launch Vehicle (Feb. 1981)

LAUNCH SCHEDULE AND MISSIONS

The NASDA launch vehicles from N-I through H-I have supported and will support various missions for space applications of Japan. The past and future launch schedule (1975 through 1988) is shown in Table 1. The status for launched missions and the scheduled missions are briefly described in Table 2.

The N-I rocket will be phased out with the expected launch of ETS-III in this August. Following the successful launch of the Geostationary Meteorological Satellite-2 in 1981, the current N-II vehicle is scheduled to support important missions for domestic communications, broadcasting and earth observations over the next several years.

If the H-I development program progresses as currently scheduled, the first test flight will be conducted in 1986 with the two-stage configuration, followed by the three-stage operational flight in the late 1980s through 1990s.

Table 1 NASDA LAUNCH VEHICLES MASTER SCHEDULE

CY	'75	'76	'77	'78	'79	'80	'81	'82	'83	'84	'85	'86	'87	'88
VEHICLE	'75	'76	'77	'78	'79	'80	'81	'82	'83	'84	'85	'86	'87	'88
N-I	ETS-I ↑ ISS ↑	ETS-II ↑	ISS-b ↑	ECS ↑	ECS-b ↑			ETS-III ↑						
N-II						ETS-IV ↑	GMS-2 ↑	CS-2a ↑	CS-2b ↑	BS-2a ↑	GMS-3 ↑	BS-2b ↑	MOS-1 ↑	
H-I											GS-1 ↑ (2 stage)		ETS-V ↑ CS-3a ↑	CS-3b ↑ (2 stage)

LAUNCHED / FIRM PLAN
 UNDER STUDY
 BACKUP FLIGHT

Table 2 NASDA PROGRAMS MISSION SUMMARY

LAUNCHED

FLIGHT NUMBER	SATELLITE NAME	LAUNCH DATE	WEIGHT (Kg)	ORBIT PARAMETERS (Km/Km/deg.)	LAUNCH VEHICLE	MISSION
1	ETS-I	9/9/75	83	1100/980/47	N-I	ENGINEERING TEST SATELLITE
2	ISS	2/29/76	139	1010/990/70	N-I	IONOSPHERE SOUNDING SATELLITE
3	ETS-II	2/23/77	130	GEOSTATIONARY	N-I	ENGINEERING TEST SATELLITE
4	ISS-b	2/16/78	141	1220/980/70	N-I	IONOSPHERE SOUNDING SATELLITE
5	ECS	2/6/79	130	-	N-I	EXPERIMENTAL COMMUNICATIONS SATELLITE MISSION FAILURE DUE TO SPACECRAFT/VEHICLE COLLISION
6	ECS-b	2/22/80	130	-	N-I	EXPERIMENTAL COMMUNICATIONS SATELLITE MISSION FAILURE DUE TO SPACECRAFT APOGEE MOTOR MALFUNCTION
7	ETS-IV	2/11/81	640	35800/225/28.5	N-II	ENGINEERING TEST SATELLITE
8	GMS-2	8/11/81	340	GEOSTATIONARY	N-II	METEOROLOGICAL SATELLITE

SCHEDULED

FLIGHT NUMBER	SATELLITE NAME	LAUNCH YEAR	APPROX. WEIGHT (Kg)	ORBIT PARAMETERS (Km/Km/deg.)	LAUNCH VEHICLE	MISSION
9	ETS-III	1982	385	1000/1000/45	N-I	ENGINEERING TEST SATELLITE
10	CS-2a	1983	350	GEOSTATIONARY	N-II	DOMESTIC COMMUNICATIONS SATELLITE
11	CS-2b	1983	350	GEOSTATIONARY	N-II	DOMESTIC COMMUNICATIONS SATELLITE
12	BS-2a	1984	355	GEOSTATIONARY	N-II	DOMESTIC BROADCASTING SATELLITE
13	GMS-3	1984	350	GEOSTATIONARY	N-II	METEOROLOGICAL SATELLITE
14	BS-2b	1985	355	GEOSTATIONARY	N-II	DOMESTIC BROADCASTING SATELLITE
15	GS-1	1986	1200	1500/1500/50	H-I	GEODETIC SATELLITE AND TEST PAYLOAD (TEST FLIGHT)
16	MOS-1	1986	750	910/910/80 SUNSYNCHRONOUS	N-II	MARINE OBSERVATION SATELLITE
17	ETS-V	1987	550	GEOSTATIONARY	H-I	ENGINEERING TEST SATELLITE
18	CS-3a	1988	550	GEOSTATIONARY	H-I	DOMESTIC COMMUNICATIONS SATELLITE
19	CS-3b	1988	550	GEOSTATIONARY	H-I	DOMESTIC COMMUNICATIONS SATELLITE

VEHICLE SYSTEM DESCRIPTION

The outboard profile of N-I, N-II and H-I rockets is illustrated in Fig. 2. An overall description of the vehicles subsystems is presented in Table 3.

The N-I rocket is a three-stage, radio-guided vehicle with overall length of 32.6 m, maximum diameter of 2.4 m and a lift-off weight of 90 tons. The first stage consists of a MB-3 engine, liquid propellant tank and three Castor-II solid strap-on boosters. The second stage propulsion system uses a regeneratively cooled LE-3 engine and a liquid propellant tank, which were developed in Japan. An off-loaded TE-364-3 solid motor of the Delta vehicle is used as the third stage.

The N-II vehicle, an upgraded version of the N-I vehicle, is 35.4 m long and 2.4 m in diameter with a lift-off weight of 135 tons. The first stage uses an Extended Long Tank with the same MB-3 engine and nine Castor-II strap-on boosters. These major first stage components are Thor-Delta hardware but license-produced in Japan.

The second stage propulsion system (SSPS), AJ10-118FJ, has been improved from the original model for the Delta 1900 series by a U.S. company: the tank volume and nozzle expansion ratio were increased. To accommodate increased payloads requested by users, this basic SSPS is being further improved: increase in the combustion chamber pressure (Pc-up)

and employment of the improved injector (ITIP). The engine is of pressure-fed, ablatively-cooled type and has a restart capability.

A larger solid motor, TE-364-4, is a Delta component applied to the N-II third stage. Also, the Delta Inertial Guidance System (DiGS) is employed for guidance and control of the vehicle.

The H-I rocket is a three-stage, inertial-guided vehicle with overall length of 40 m, maximum diameter of 2.4 m and a lift-off weight of 140 tons. The first stage and strap-on boosters of the H-I vehicle are the same as those of the N-II vehicle. Much efforts are being concentrated on the development of new upper stages with high performance.

The second stage propulsion system uses liquid oxygen and liquid hydrogen as propellants, with an average vacuum thrust of 10 tons and a vacuum specific impulse of 442 sec. A new large solid motor with the propellant weight of 1.9 tons is being developed to be used for the third stage. An inertial guidance system of stable platform type will be used for guidance and control of the vehicle.

Various development tests of these major components have been carried out by domestic efforts with a substantial progress.

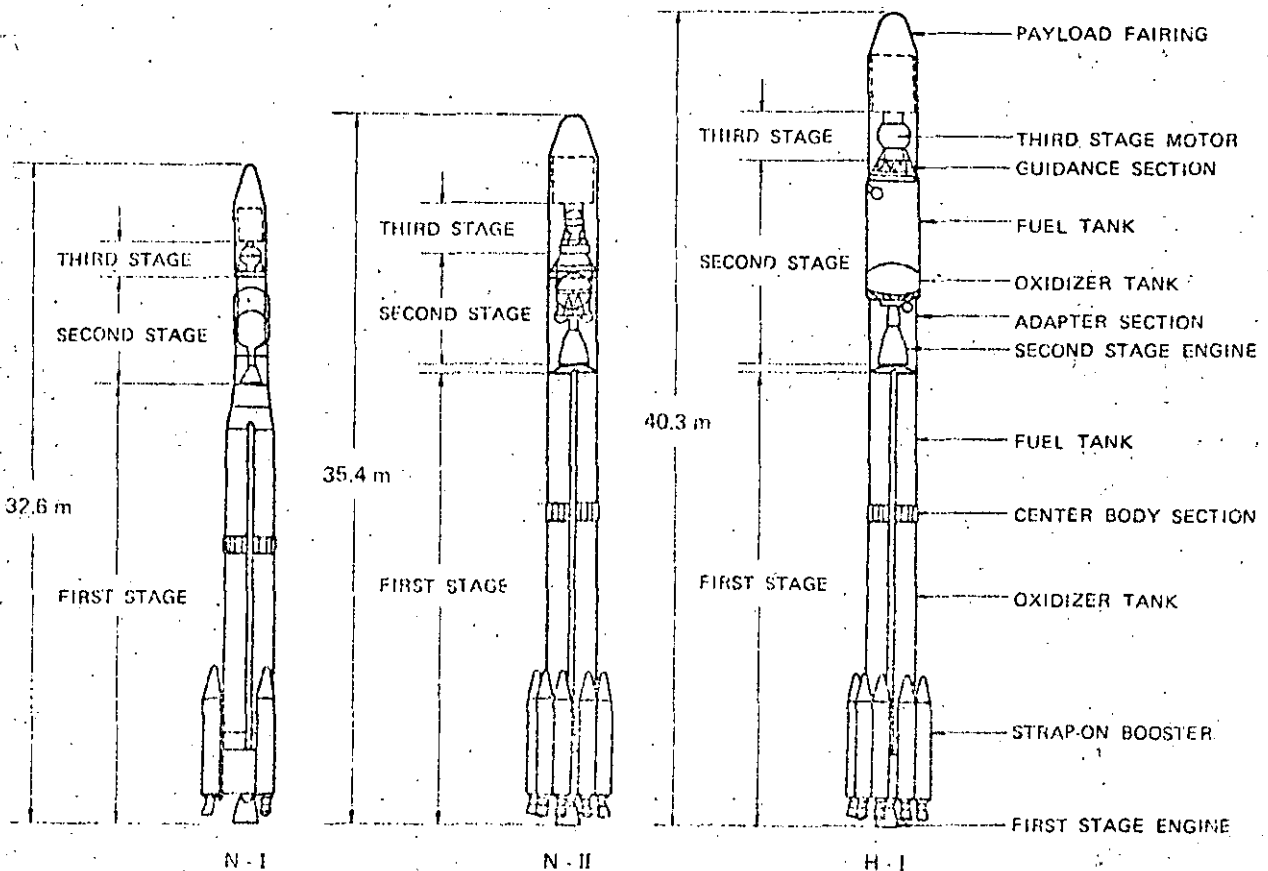


Fig. 2 OUTBOARD PROFILE COMPARISONS

Table 3 MAIN CHARACTERISTICS OF N-I, N-II AND H-I VEHICLES

SIZE	OVERALL LENGTH (m) DIAMETER (m) LIFT OFF WEIGHT (APPROX. TON)	VEHICLE		
		N-I	N-II	H-I
FIRST STAGE	ENGINE PROPELLANT AVERAGE THRUST (TON, SEA LEVEL) SPECIFIC IMPULSE (SEC, SEA LEVEL) TOTAL/PROPELLANT WEIGHT (TON)	MB-3 LOX/RJ-1 78 249 70/66	MB-3 LOX/RJ-1 78 249 86/81	MB-3 LOX/RJ-1 78 249 86/81
STRAP ON BOOSTER	MOTOR PROPELLANT AVERAGE THRUST (TON, SEA LEVEL) SPECIFIC IMPULSE (SEC, SEA LEVEL) TOTAL/PROPELLANT WEIGHT (TON)	CASTOR II SOLID 23.7 x 3 238 4.5/3.8 x 3	CASTOR II SOLID 23.7 x 9 238 4.5/3.8 x 9	CASTOR II SOLID 23.7 x 9 238 4.5/3.8 x 9
SECOND STAGE	ENGINE PROPELLANT AVERAGE THRUST (TON, VACUUM) SPECIFIC IMPULSE (SEC, VACUUM) TOTAL/PROPELLANT WEIGHT (TON)	LE-3 N ₂ O ₄ /A-50 5.4 285 5.8/4.7	AJ10-118FJ N ₂ O ₄ /A-50 4.4 315 - 319 (ITIP) 6.8/5.8	LE-5 LOX/LH ₂ 10.5 442 10.6/8.6
THIRD STAGE	MOTOR PROPELLANT AVERAGE THRUST (TON, VACUUM) SPECIFIC IMPULSE (SEC, VACUUM) PROPELLANT WEIGHT (TON)	TE-364-14 SOLID 4.0 290 0.56	TE-364-4 SOLID 6.8 286 1.05	SOLID 9.0 288 1.9
FAIRING	DIAMETER (m) MAX. SPACECRAFT DIAMETER (m)	1.7 1.4	2.4 2.2	2.4 2.2
	GUIDANCE SYSTEM	RADIO GUIDANCE	DELTA INERTIAL GUIDANCE SYSTEM	INERTIAL GUIDANCE SYSTEM

PERFORMANCE GROWTH

Figure 3 shows a schematic presentation of NASDA vehicles performance growth in terms of geosynchronous payload. The performance capability of the current N (N-II) vehicle was greatly increased as a result of improvements described above over the basic N (N-I) vehicle.

It is noted here that the current N-II launch vehicle has a similar configuration as the Delta 1910 series, while its capability is rather close to the 2910 series. The same ITIP SSPS hardware will be used for the new Delta 3920 series.

Much higher performance growth is expected of the H-I vehicle due to the use of a cryogenic propulsion system and an optimum (larger) third stage motor.

A feasibility study is being carried out to further upgrade the payload capability of the presently defined H-I launch vehicle.

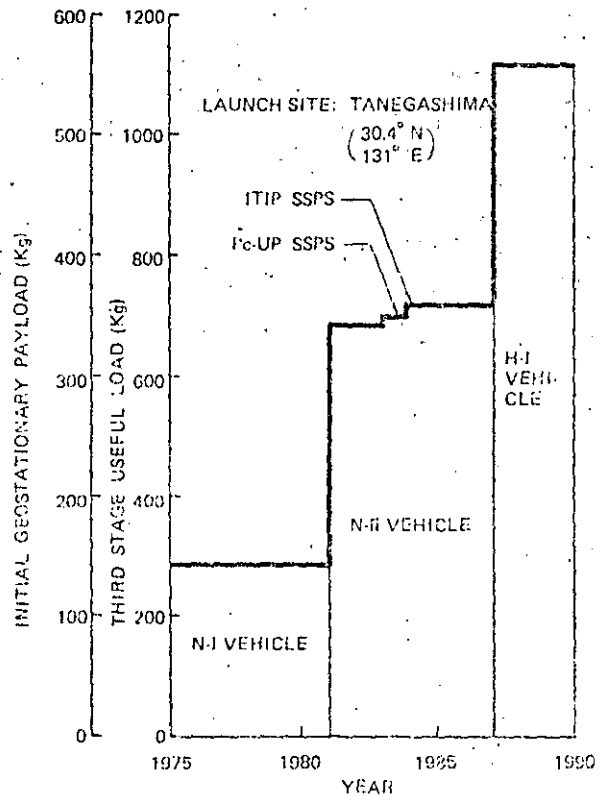


Fig. 3 GEOSYNCHRONOUS PERFORMANCE GROWTH

SPACECRAFT TECHNOLOGY FOR DIRECT BROADCAST MISSIONS

Herbert D. Cohen

TRW Space and Technology Group

ABSTRACT

This paper surveys the technologies required for presently conceived direct broadcast satellite (DBS) projects. The technologies include launch vehicles, shaped beam antennas, high power traveling wave tubes (TWT^s), electronic power conditioners for TWT^s, lightweight, high power solar arrays, heat pipe radiators and output multiplexers. It is concluded that the technology is available and only detailed engineering development and test is required for DBS construction.

INTRODUCTION

The term direct broadcast has been applied to a variety of satellite programs covering the frequencies from 850 MHz to 20 GHz and beyond. For the purposes of this paper, we shall restrict our discussion to the 12 GHz band and to TV broadcast direct to the home (DBS). DBS is yet in its infancy but has evoked a tremendous response for potential commercial exploitation both for conventional and high definition (HDTV) applications. Nonetheless, past, present and future programs span a wide range of spacecraft size and use different levels of key technologies. A technologically representative set of programs and studies listed in Table 1 includes Delta class and greater than Atlas-Centaur class satellites. A small domestic communications satellite (Anik B) using a 20 watt traveling wave tube (TWT) and less than 1 kilowatt output solar array is presently performing a pre-operational mission in Canada, while a Nordic satellite study utilizes a 450 watt TWT requirement and a 9 kilowatt solar array. Satellite designs are often required to meet dual launch requirements of expendables (Ariane) and Shuttle and may require special ascent stages intermediate to PAM A and IUS.

TABLE 1. TECHNOLOGICALLY REPRESENTATIVE DBS SYSTEMS

PROGRAM	STATUS	ANTENNA	RF STAGE	TWT OUTPUT (WATTS)	SOLAR ARRAY OUTPUT (D.E. (WATTS))	LAUNCH VEHICLE OR ORBIT MASS (LBS)	THERMAL DESIGN
ANIK B	OPERATIONAL	DIPOLE OFFSET PARABOLA SIMPLE FEED	NO	20	1000	DELTA 7000 1000	NO HEATPIPES
ANIK C2	FLOOR DEVELOPMENT	DIPOLE OFFSET PARABOLA SIMPLE FEED	YES	100	1000	DELTA 7000 1000	NO HEATPIPES
EUROSPONG	PLANNED	DIPOLE OFFSET PARABOLA SIMPLE FEED	YES	65-70	1000	SIX PAM D OR ARIANE 4	
EBI-17545T	DEVELOPMENT	DIPOLE OFFSET PARABOLA COMPLEX FEED	YES	230-250	2000	ARIANE 7	SIMPLE AND VARIABLE CONDUCTANCE HEATPIPES
STC COMBAT	PLANNED	DIPOLE OFFSET PARABOLA COMPLEX FEED	NO	200	2000	STS PAM D OR DUAL ARIANE 3 1200	PROBABLY SIMPLE HEATPIPES
ESD	PLANNED	DIPOLE OFFSET PARABOLA COMPLEX FEED	YES	2-3300 OR 150	4000	STS PAM A OR ARIANE 40 2000	PROBABLY SIMPLE HEATPIPES
NORDSAT	STUDY	DIPOLE OFFSET PARABOLA COMPLEX FEED	YES	200-600 500	6000	STS INTEGRATED PROVISION OR ARIANE 4P 2000	SIMPLE AND COMPLEX VARIABLE CONDUCTANCE HEAT PIPIES

This paper surveys the technologies required for presently conceived DBS projects. These are summarized in Table 2. These include shaped beam antennas (12/18 GHz) which cover irregular national or regional footprints to maximize EIRP, limit sidelobe levels and provide polarization purity for either linear or circular polarization; TWT^s at power levels up to 450 watts designed for 7-10 year lifetimes, with multiple collectors for high efficiency (approximately 50 percent), with collectors radiating 65-70 percent

TABLE 2. SATELLITE TECHNOLOGY FOR DBS

ITEM	FEATURES	STATUS
LAUNCH VEHICLE (STS AND ARIANE)	• 1500-3000 LBS IN-ORBIT	ADVANCED DEVELOPMENT
ASCENT STAGE (PAM D, PAM A, SPECIAL)	• EFFICIENT, FLEXIBLE	ADVANCED DEVELOPMENT OR NEW
SOLAR ARRAY (1-10 KW)	• LIGHTWEIGHT (25-30 KG/KW)	ADVANCED DEVELOPMENT OR NEW
ANTENNA (12-18 GHz)	• SHAPED BEAM • OFFSET FEED, OVER-SIZED, PARABOLA • MULTIPLE FEED • SIDELobe CONTROL, LOW CROSSPOL • DUAL POLARIZATION	TECHNOLOGY DEVELOPED, NEW APPLICATION
HIGH POWER TWT (100-450W)	• LONG LIFE, DISPENSER CATHODE (7-10 YRS) • MULTIPLE COLLECTOR, HIGH EFFICIENCY (50%) • DIRECT RADIATING COLLECTOR • HIGH COLLECTOR BODY DISSIPATION (85% 35%)	ADVANCED DEVELOPMENT
TWT EPC	• HIGH VOLTAGE (6-15 KV) • HIGH EFFICIENCY (88-90%) • PACKAGING (POTTED VS OPEN)	OPEN PACKAGING SUCCESSFULLY DEMONSTRATED FLOOR POTTED TECHNOLOGY TO BE DEMONSTRATED
HEAT PIPE RADIATOR	• SIMPLE AND VARIABLE CONDUCTANCE	TECHNOLOGY DEVELOPED, NEW APPLICATION
HIGH POWER MULTIPLEXER	• HIGH/LOW LOSS • GOOD HEAT TRANSFER • RIGID MULTIPACTION	TECHNOLOGY DEVELOPED, NEW APPLICATION

of the dissipated energy directly to space and using either helix or coupled cavity slow wave structures; TWT electronic power conditioners (EPC) requiring high voltage (6-15 kv) supplies, with high efficiency (88-90 percent), operating from low voltage or high voltage (100 volts and higher) regulated or unregulated DC power supplies, using potted or open construction; lightweight solar arrays (25-30 kg/kw) providing end-of-life outputs up to 10 kilowatts with limited or no transfer orbit stowed capability; heat pipe radiators simple and variable conductance, coupled and uncoupled, to spread high heat concentrations with different spatial geometries engendered by redundancy modes on common radiators, to survive eclipse with sharply reduced or zero dissipation or to transfer heat from confined geometries with high heat concentrations (output multiplexers); and high power output multiplexers, contiguous combining high Q (for low insertion loss), good heat transfer and avoiding potential multipaction caused by high frequency and high voltage.

Most of the technologies can be seen installed on a four kw class DBS satellite (Figure 1), carrying six channels of 230 watt TWT^s with two for one redundancy. The TWT^s and EPC^s are mounted on the North-South panels (from which the solar arrays protrude) so that the collectors radiate directly to space. Heat pipe radiators are used to spread the heat on the North-South panels and also on the top panel where the output multiplexer is installed.

LAUNCH VEHICLE

Geosynchronous orbit performance for a range of expendable and shuttle based launch vehicles is presented in Table 3. The key boosters for DBS are still in the development stage. This includes the Ariane series and the STS/PAM-D and STS/PAM-A. The Ariane list is incomplete since it skips, presently used vehicles and goes directly to the 1985 era and beyond. The Ariane 4 family is just being introduced for 1986 availability and hence only a few typical choices are shown to illustrate the range of payload capability.

Note that performance calculations have been done for the most part using available Thiokol solid apogee motors for comparison. It is recognized that in some cases a liquid will provide somewhat better performance. The beginning of life satellite weight includes various allowances footnoted in Table 3 enabling a comparison between

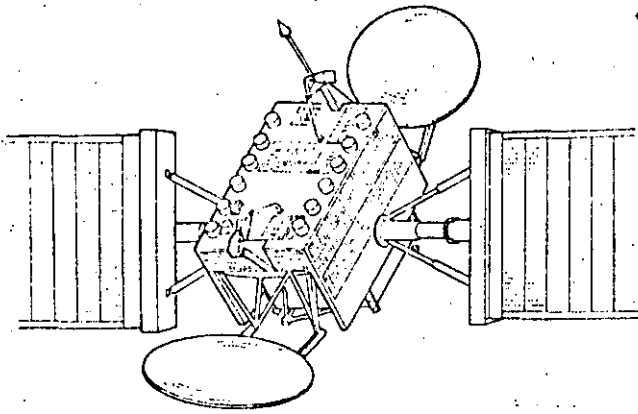


Figure 1. DBS Spacecraft

stages having diverse initial maneuver requirements. Hydrazine is used with a continuous thrust specific impulse of 220 seconds.

STS/PAM-D and STS/PAM-A performance can be "stretched" using an oversized liquid system which provides some of the perigee velocity requirements (ΔV) in addition to the apogee ΔV . The payload gain slope is low providing 100 pounds of additional payload for each 500 pounds of propellant added. The LEASAT integrated propulsion system also uses this technique.

TABLE 3. LAUNCH VEHICLE GEOSYNCHRONOUS ORBIT PERFORMANCE COMPARISON

LAUNCH VEHICLE	WEIGHTS ⁽¹⁾		BURST WEIGHT LIFE ⁽²⁾		MAXIMUM SATELLITE DIAMETER	
	LBS	KG	LBS	KG	FT	M
IRIDIUM	2,760	1,250	1,300	625	7.7	2.3
DELTA 3500	4,150	1,885	2,100	1,225	9.5	2.9
ATLAS CENTAUR	2,515	1,140	1,600	670	10.0	3.0
ARIANE 3 DUAL LAUNCH	4,410	2,000	2,100	1,045	12.0	3.65
ARIANE 30	4,220	1,915	2,200	1,015	12.0	3.65
ARIANE 4L DUAL LAUNCH	9,360	4,200	5,000	2,268	12.0	3.65
ARIANE 5L						
SATELLITE						
STS PAM D	2,760	1,250	1,300	625	9.10 ⁽³⁾	2.73 ⁽⁴⁾
STS PAM A	4,400	2,000	2,150	960	14.5	4.4
STS HS			4,800	2,170	14.5	4.4
STS INTEGRATED PROPULSION			10,000	4,540	14.5	4.4
STS CENTAUR			11,000	5,000	14.5	4.4

(1) LAUNCHER ORBIT INCLINATION CHOSEN TO MAXIMIZE PAYLOAD AND ADAPT TO AVAILABLE APPOGE MOTOR
 (2) USE EXISTING THROAT SIZE APPOGE MOTOR WHEN AVAILABLE. INCLUDES ALLOWANCE FOR ACADAPTOR SPIN DEPLOY ACQUISITION AND INITIAL VELOCITY CORRECTION.
 (3) 300 INCHES VERTICALLY IN SHUTTLE BAY

ANTENNA

Antenna coverage for DBS is either elliptical as represented by the WARC '77 assignments in Regions 1 and 3 or irregularly shaped as exemplified by U. S. time zone coverage. Figure 2 shows U. S. service areas with modified time zone boundaries, which are roughly equal in area when seen from four satellites (one per zone) located at 115° West longitude (W), 135°W, 165°W and 175°W (Ref. 1). Equal areas enable the use of equal power TWT⁵. Shaped beam antennas will be required to maximize gain and low sidelobes and crosspol will be required to minimize interference to adjoining regions.

The technology, both software and hardware, has been demonstrated at Ku-band by a study performed for NASA Langley by TRW (Ref. 2). Figure 3 shows the shaped beam antenna geometry for the coverage of the true Eastern Time Zone as seen from a satellite located at 98°W. Linear polarization enables the use of a vertical grid subreflector so that the aperture can be reused and all four time zones can be implemented as shown. An offset parabolic reflector with a 2.3 meter diameter (D), a 25 horn feed and an F/D = 1.25 is employed. The resulting directivity contours are shown in Figure 4. Coverage is roughly at the -2 dB contour and the gain slope around the contour is uniform and roughly 10 dB/degree providing low susceptibility to attitude control errors. Special pains have been taken to control sidelobes so that a -35 dB level is achieved at the border of the Central Time Zone to enable frequency reuse.

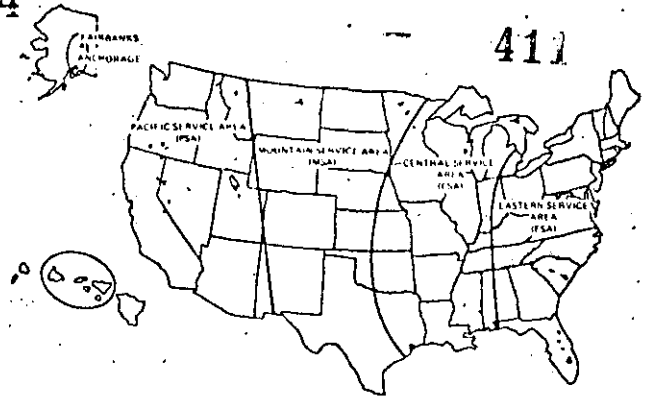


Figure 2. Conus Service Areas and Coverage of Alaska and Hawaii

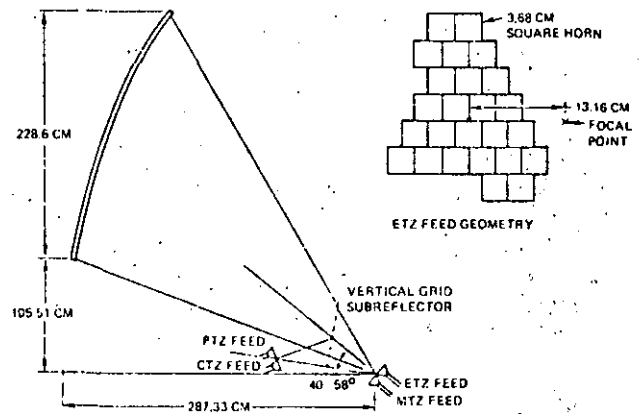


Figure 3. Contoured Beam Antenna Configuration

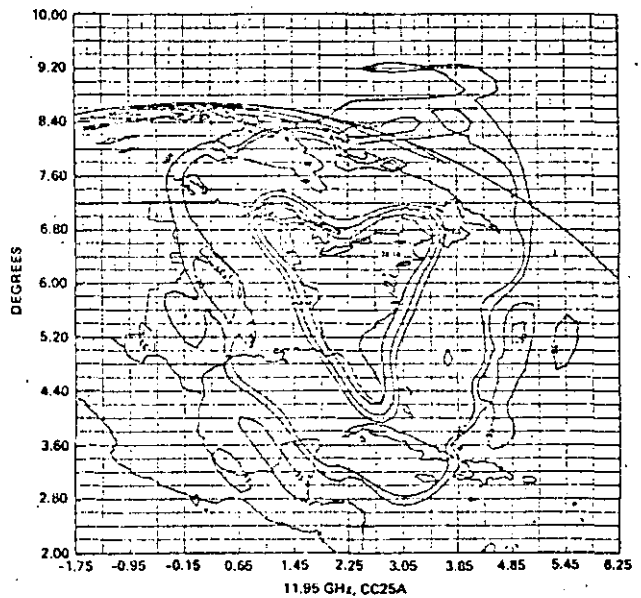


Figure 4. Beam Isolation Contours at 11.95 GHz

Additional horns are used around the periphery of the feed network for this purpose (Ref. 7).

The software technology is illustrated by a comparison of calculated and measured results shown in Figure 5. There is good agreement in contour and sidelobe structure to about the -20 to 25 dB level. Lower level sidelobes and crosspol must be verified by measurements employing good mechanical simulations of actual spacecraft installation. Figure 6 is a photograph of the 25 horn feed which was built and tested. Note that the antenna was designed for both transmit and receive across the 11.7 to 14.5 GHz band. Uniform results were obtained across the band.

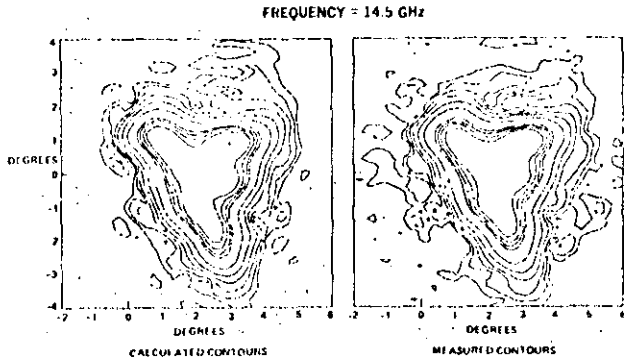


Figure 5. Comparison of Calculated and Measured Gain Contours

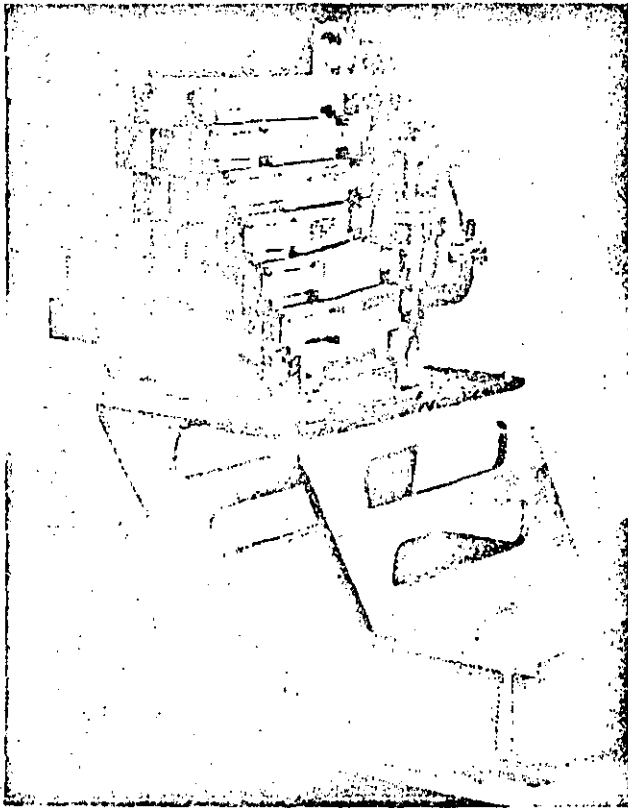


Figure 6. ETZ Feed Cluster

U. S. DBS satellites will most probably use circular polarization and each satellite will provide 3-6 channels to one of the service areas at 12 GHz as defined above. Each satellite antenna will be designed to cover two service areas from the designated orbital locations for the purpose of in-orbit sparring. Uplinking at 18 GHz

will be from the Las Vegas/Los Angeles area. Figure 7 shows the antenna layout and feed geometry for an Eastern type satellite which can cover either the Eastern Service Area from 115°W or the Central Service Area from 135°W. In addition, a separate set of feeds in four horn monopulse arrangement is provided for the Las Vegas uplink and RF sensing. In this case the antenna designer has been constrained to work with an $F/D = 0.9$ for spacecraft mechanical design reasons. Antenna directivity contours are shown on Figure 8 for the Eastern Service Area. Again, excellent coverage at the -2 dB contour and sidelobe control have been obtained.

It is noteworthy that mini-max computer optimization programs have been implemented to weight the antenna gain distribution as a function of a set of gain requirements. This technique can be used to provide additional gain to rainy areas assuming equal home receiver G/T or to equalize RF power budget margins assuming graduated values of home receiver G/T as a function of rain.

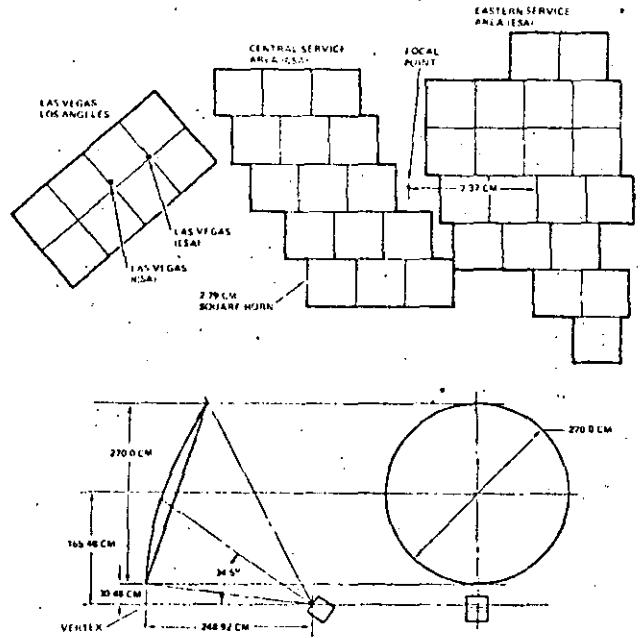


Figure 7. Eastern/Central Satellite Antenna Configuration

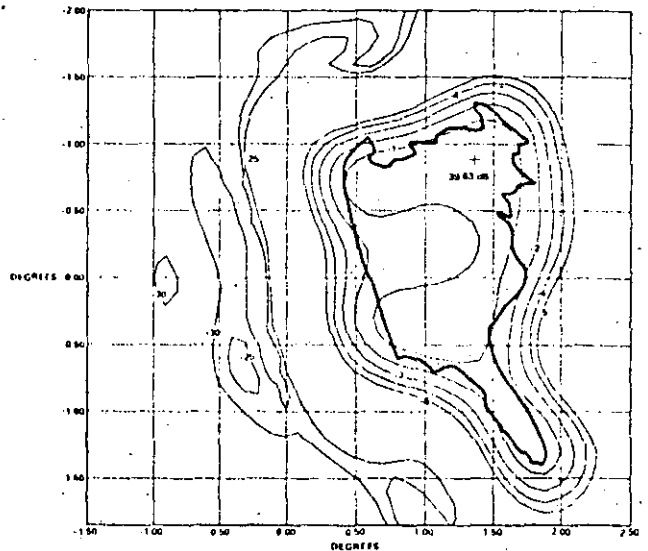
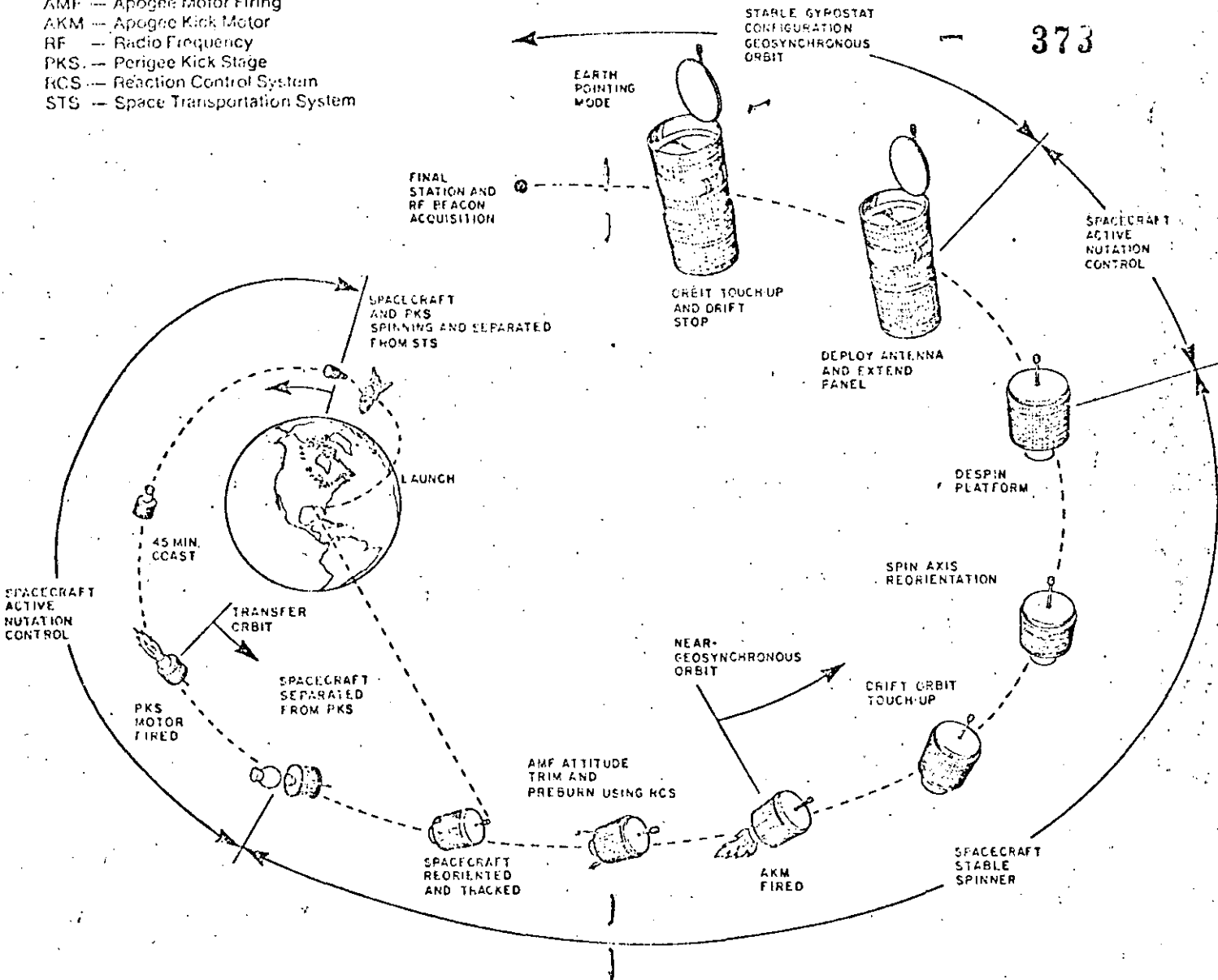


Figure 8. Antenna Directivity Contours Spacecraft at 115°W

Abbreviations:

- AMF --- Apogee Motor Firing
- AKM --- Apogee Kick Motor
- RF --- Radio Frequency
- PKS --- Perigee Kick Stage
- RCS --- Reaction Control System
- STS --- Space Transportation System



Colocación en órbita con el transbordador espacial Columbia

MANTENIMIENTO DE LA POSICION RELATIVA RESPECTO AL EJE DE LA TIERRA (Satellite Attitude)

Existen dos métodos para estabilizar la posición relativa del satélite con respecto al eje de rotación de la tierra. Esta estabilización es necesaria ya que las antenas del satélite deben apuntar permanentemente hacia la zona que esté recibiendo el servicio. Las dos alternativas son estabilización por rotación del cuerpo del satélite (lo cual involucra rotación simultánea del subsistema de antenas en sentido contrario) y estabilización de tres ejes (que no involucra rotación).

En el caso de estabilización por rotación, las celdas solares están montadas sobre el cuerpo en forma de barril del satélite. Al usar estabilización de tres ejes, con un propulsor ó dispositivo de momento independiente por eje, las celdas solares pueden montarse sobre paneles planos que se orientan óptimamente hacia el sol. Los arreglos solares dispuestos de esta manera son \uparrow veces más eficientes que los dispuestos alrededor del cuerpo del satélite (ó sea que para generar la misma potencia, un satélite con estabilización de tres ejes requiere $1/\uparrow$ veces menos celdas solares que un satélite rotativo).

Un satélite rotativo maneja del orden de 1 KW de potencia y uno con estabilización de tres ejes y paletas de celdas solares móviles maneja alrededor de 10 KW.

C O M S A T

348

LAUNCH CONTROL CENTER

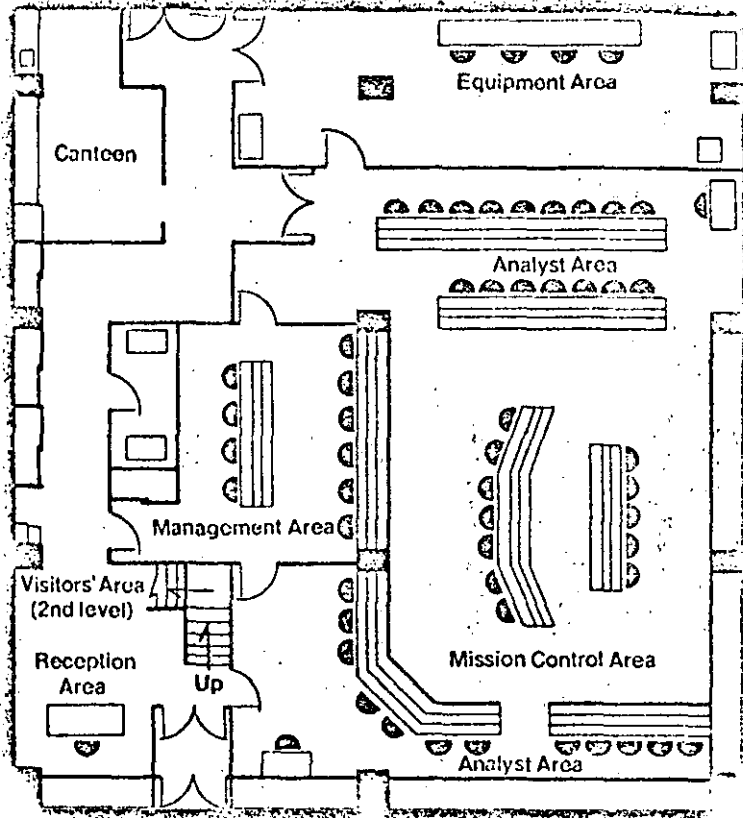
Design Based on Experience

COMSAT has successfully placed into synchronous orbit more than 35 communications satellites, including the most advanced generation of INTELSAT Vs, with a capacity of more than 12,000 circuits plus two TV channels. COMSAT's pioneering efforts in this field began in 1965 with the launching of Early Bird, the world's first commercial communications satellite.

COMSAT designed the Launch Control Center in response to the need for a more versatile facility to meet the data requirements of the most complex satellites of the next decade. These demands are met utilizing the latest in data processing and display capabilities. The LCC has been optimized for launch operations, drawing upon experience gained in more than 15 years of launch, transfer orbit, and subsequent in-orbit operations and systems management.

Capable of managing all phases of satellite operations, the Launch Control Center is dedicated to meeting launch and transfer orbit requirements of spin-stabilized and three-axis satellites, including response to in-orbit anomalies or emergencies. The physical layout provides for grouping of related engineering specialists, providing visual contact among the groups, while enforcing operational discipline.

Left: Mission control viewed from Management area.



- Equipment Area** - houses the data processing, storage, distribution and other electronic equipment.
- Visitors' Area** - provides for the reception of special dignitaries. Seating is provided for up to 15 persons.
- Management Area** - area of 10 workstations for the management of the center.
- Analyst Area** - provides for 24 console positions for the analysis of data.
- Reception Area** - provides for the reception of visitors and the issuance of identification badges.
- Visitors' Area** - provides for the reception of special dignitaries. Seating is provided for up to 15 persons.
- Canteen** - provides for the refreshment of the staff.

Flexible and Adaptable

The LCC is equipped with the latest that technology offers. Its flexible data processing system is designed to accommodate a number of spacecraft programs through utilization of appropriate software.

Redundant data processing systems are provided to ensure continuity of operation in the event of a failure of one of the Launch Control Center's processors. In addition, the configuration provides a capability for multiple spacecraft operations or simultaneous real-time and off-line recorded data processing. The dual computers, under executive control, process telemetry and command data received by the LCC. They have extended memory and a switchable I/O extender.

The LCC is equipped with various display and recording devices, including two eight-channel strip chart recorders, a four-channel high-speed light oscillograph, and two 14-track analog tape recorders. The Center interfaces with an IBM 3032 computer system located at COMSAT Laboratories in Clarksburg, Maryland. This system processes incoming telemetry information and is used for orbit determination, maneuver message generation, and real-time graphic displays for monitoring spacecraft maneuvers.

Processed alpha-numeric displays in 20 data formats are distributed throughout the LCC to two CRT's at each console position. Any of the 20 displays can be individually selected on a CRT by thumbwheel selection. A hard copy of the video display can be obtained from either of two separate units.

Left: Mission Control viewed from Analyst area.

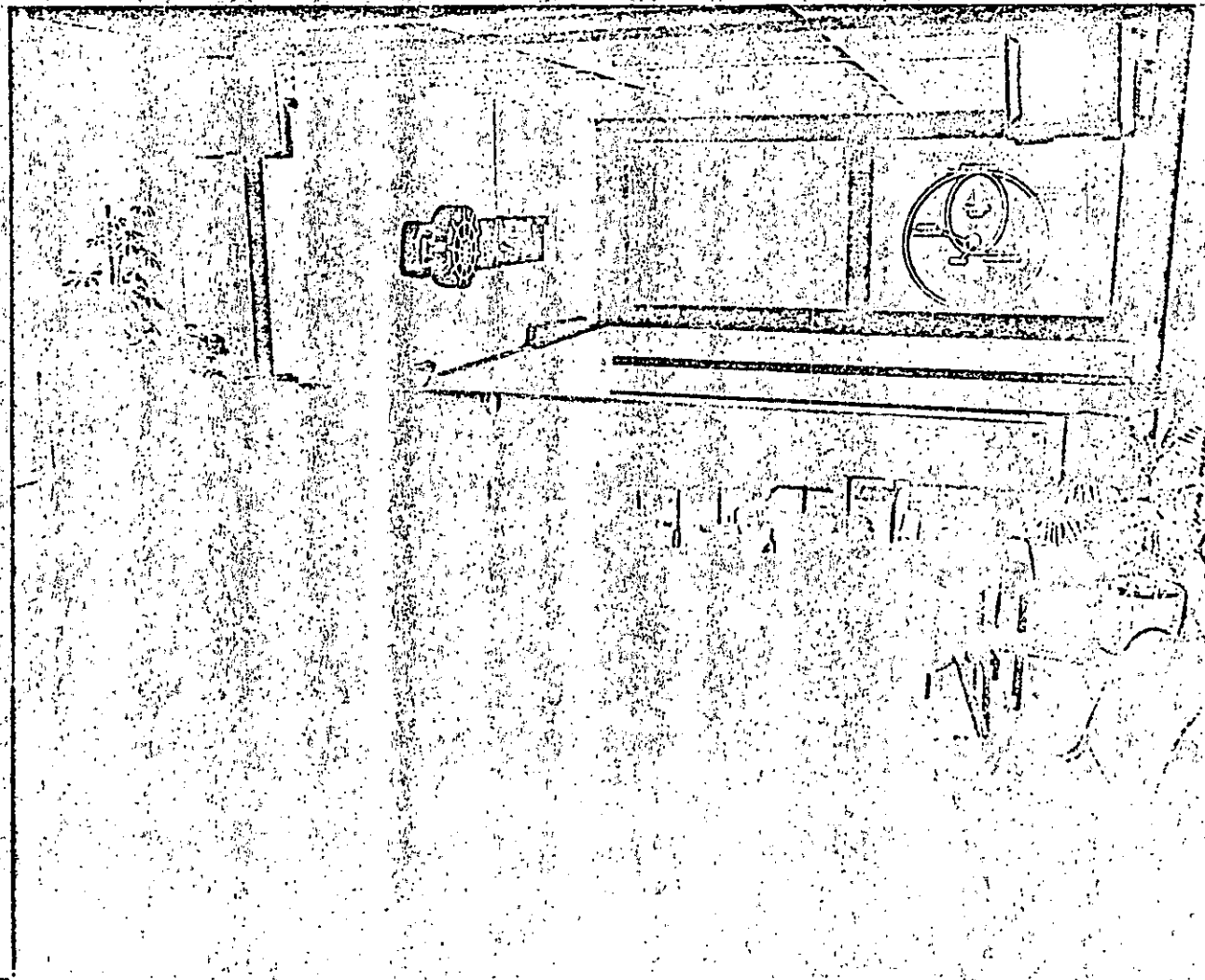
Right: Mission Control area.

Communications internal to the LCC are provided by an eight-channel intercom system which allows users to be active on one network while monitoring other networks. Communications external to the LCC are provided by a computer-driven private phone system which operates independently of the main COMSAT system. External sources, such as incoming or outgoing phone calls, can be routed to any console position or conferenced through a group of positions. These sources also can be interfaced with the intercom system in either an active or monitor mode.

A large screen video projection system can display any of the 20 different computer-generated graphics available in the LCC on one of two screens — each measuring 10 feet by 7.5 feet — mounted above the main floor of the facility. Also available for display is an activities schedule; live video from Cape Canaveral or the Center itself, or video taped presentations. The second screen is used for presentation of 35mm slide material. These screens are visible from both the main floor and the visitors' area.

Left: Equipment area

Below: Visitors' area located above Management area



SATELITES QUE SERAN

352

COLOCADOS EN ORBITA DE

1982 A 1985

Even more communications in orbit

This latest guide lists the operating characteristics of satellites being launched in the next three years

by the staff of Satellite Engineering Inc., Bethesda, Md.

□ Communications satellites are rapidly revolutionizing the ways in which people communicate by offering such services as video teleconferencing and electronic mail besides the now well-accepted telephone, television, and data transmissions. Approximately 90 active communications satellites orbit the earth today—some 15 more than when Electronics last published this guide on Sept. 11, 1980, and 35 more than in the Oct. 12, 1978, issue. As many as 100 more birds are planned for launch in the next decade.

To obviate any undue repetition, this second update of the guide concentrates on those systems being launched in the next three years that were not described in the 1980 chart. Moreover, systems scheduled for mid-decade or beyond—for example, the U.S. and European direct-broadcasting satellites—are not included since their technical parameters have not been finally set nor their prime contractors selected.

The entries on the chart have been classified in accordance with the international Telecommunications Union usage as fixed, mobile, broadcast, and military. Also indicated is their international, regional, or domestic status. The international category is self-explanatory. Systems are considered regional when they serve a geographical or linguistic grouping, but different political entities are involved. Domestic systems administer to one country only.

Launching options

In the past, most communications satellites were launched either from Cape Canaveral in the U.S. or from Plesetsk or Tyuratam in the USSR. But last year an Indian communications satellite was carried into earth orbit by the French Ariane vehicle launched from Kourou, French Guiana. The success of the Ariane launch presages stiff, low-cost competition for the U.S. shuttle system. In fact, a number of operators who had planned launches with the shuttle have now made firm reservations on Ariane.

Almost all communications satellites are placed into geostationary orbits. After liftoff by means of a booster rocket, the satellite attains a circular low-altitude parking orbit from which it is transferred to a circular geostationary orbit via an elliptical transfer orbit. Firing the perigee kick motor moves the satellite from parking to transfer, and firing of the apogee motor modifies its velocity and moves it into the desired geostationary orbit. During these maneuvers, the mass of the satellite decreases with the diminishing amount of propellant fluid—a fact that, incidentally, complicates satellite mass calculations.

The exception to this positioning process is the Molniya series of satellites, which spin around the earth in a highly inclined elliptical orbit and for most of the time are in view of northern regions of the USSR, such as Siberia. These satellites are used for the Washington-Moscow hotline.

How heavy is it?

The numbers given in the chart for the mass and primary power of satellites are to be used with caution. The mass is generally quoted in operating orbit. But there may be some uncertainty as to whether these numbers do or do not include such factors as on-board propellants. Thus, the mass given is noted as being either an operational figure or one at launch, or beginning of life, as satellite watchers term it.

Even more uncertain are the primary power numbers. These can be quoted at the beginning or end of life and at either the equinox or solstice. Since the total range can be considerable, the probable case is indicated where possible. Otherwise, the best assumption is that the power is the system's at the beginning of its life during equinox.

Only an approximate picture can be given of the kinds of transponders, or satellite channels, and antenna beams available. This is because the system block diagrams of most of these satellites show great variety in redundancy, switching possibilities, and bandwidths. The number of transponders is equal to the number of radio-frequency channels with the bandwidths shown in the appropriate row on the chart.

The satellite receiver figure of merit may have more than one value. These values apply to different beams or transponders or bandwidths, as is evident from the chart.

As noted, some satellite systems are not listed on the chart—even though they will open major communication markets—because they will not be launched until mid-decade and their specifications are not final. Among these are the systems of eight firms in the U.S. that have applied to the Federal Communications Commission to put satellites up to broadcast television programs directly to people's homes. The signals would go directly from the Ku-band (12-to-14-gigahertz) satellites to specially designed small parabolic rooftop antennas. The home receivers that work with these antennas will be the first mass consumer market for gallium arsenide-based microwave integrated circuits. [Electronics, June 30, 1982, p. 92]

Reprints of the chart opposite or the 1980 chart cost \$5 each. Write to Electronics Dept., 1221 Avenue of the Americas, New York, N.Y. 10020, specifying which charts are being requested. Copyright 1982 Electronics, a McGraw-Hill publication.

357

381

ARTICULOS SOBRE VEHICULOS

DE LANZAMIENTO

354

GTE G-Sta	Systems	INTERNATIONAL FIXED						INTERNATIONAL MOBILE		REGIONAL			
		Intelsat V		Intelsat Va		Intelsat VI		USSR/ Intersputnik Raduga		Inmarsat Marecs		S. E. Asia Palapa 2	Arab League Arabsat
RCA Astr electronic	Prime contractor	Ford Aerospace		Ford Aerospace		Hughes		—		British Aerospace		Hughes	Aerospatiale
3 planned (103, 106 97 or 119	Number (and position) of satellites	3 active (22, 24 W, 60 E), 1 spare, 5 more planned with MCS ¹⁰		6 planned (positions not yet deter- mined)		5 contracted for; up to 16 planned (positions not yet determined)		7 active (90 to 35 E) plus 3 in orbit only		1 active (26 W), 2 more planned		2 planned (108, 113 or 118 E)	2 planned (19, 26 E)
KU or CC April 1982; late 1984, early 1982	Place of launch and date	CC Dec. 1980, May 1981, Dec. 1981, March 1982		CC first launch 1984; later from CC or KU		CC or KU first launch 1986		TY 1978-81;		KU Dec. 1981, June 1982 planned; third launch undetermined		CC April 1983, Jan. 1984	CC or KU April 1983, Aug. 1984
Ariane, Del or shuttle	Launch vehicle	Atlas Centaur		Atlas Centaur or Ariane		shuttle or Ariane		Proton-SL-12		Ariane or shuttle		Thor Delta 3920	Ariane
fixed data and possib DBS	Service ²	international fixed tel., TVD, TTY, data, and some domestic leases		international fixed tel., TVD, TTY, data, and some domestic leases		international fixed tel., TVD, TTY, data, and some domestic leases		international fixed tel., TVD, and telegraph		mobile tel., TTY		regional fixed tel., TVD	regional fixed tel., TVD
3-axis	Stabilization	3-axis		3-axis		spin		3-axis		3-axis		spin	3-axis
670 in orb BOL	Mass ³ (kg)	1,870 at launch 1,020 in orbit ¹¹		2,141 at launch 1,160 in orbit ¹¹		3,407 at launch 2,004 in orbit BOL		1,500 at launch		572 BOL		628 in orbit BOL 532 EOL	680 in orbit
1,350 EOL ss	Primary power ³ (W)	1,800 BOL 1,300 EOL		see Intelsat V		2,260		700		775 BOL 748 EOL		831 EOL ss	1,300 EOL
Ku	Frequencies ⁴	C	Ku	C	Ku	C	Ku	C	L ship	C shore	C	C	S
16	Number of transponders per satellite ⁵	25	6	32	6	36	10	7	1	1	24	25	1
54	Transponder bandwidth (MHz)	36 41 72 77	72 77 241	see Intelsat V		36 41 72 77	72 77 150	40	4.75	5.9	36	33	33
20, 30	Transponder output power (W)	10	10	10	10	8.5	40	n. a.	n. a.	10	n. a.	n. a.	n. a.
3 Rx 3 Tx	Number of antenna beams ⁶	5 Rx 5 Tx	2 Rx 2 Tx	see Intelsat V		7 Rx 7 Tx	2 Rx 2 Tx	2-4 total	1 Rx 1 Tx	1 Rx 1 Tx	1 Rx 1 Tx	1 Rx 1 Tx	1 Tx
linear	Polarization	circular	linear	see Intelsat V		circular	linear	circular	circular	circular	linear	circular	linear
-1.5 to -4.8	G/T ⁷ (figure of merit, dB/K) and coverage ⁸	-18.6 gl -11.6 he -8.5 zo	0 es 3.3 ws	see Intelsat V		-15.0 gl -8.5 he -7.0 zo -1.0 zo	1.0 es 4.3 ws	-15.8	18.8 per carrier	-2.5 per carrier	-5 Indonesia -7 ASEAN	-7.5	-7.5
40 to 42	Effective isotropic radiated power ⁹ (dBW)	23.5 gl 26.5 gl 26 he 29 he 29 zo	41.4 es 44.4 ws	see Intelsat V		23.5 gl 31 he 28 zo	41.1 es 44.4 ws	25 to 36	32	32	34 Indonesia 32 EOC	31 min	41 min
n. a.	Saturation flux density (dBW/m ²) (single carrier)	-75 gl, he -72 gl, he -72 zo	-77 es -80 ws	see Intelsat V		-77.6 (adjust- able)	-78.4 es -81.3 ws	n. a.	-85 to -106 (adjustable)	-123	-89.5	n. a.	n. a.

¹CC - Cape Canaveral, USA
²KU - Kourou, French Guiana
³PL - Plesetsk, USSR
⁴TY - Tyuratam, USSR
⁵TA - Tanigahima, Japan

⁶fixed - satellite service to specified fixed points
⁷mobile - satellite service to ships, airplanes and mobile ground terminals
⁸public - satellite service intended for reception by the general public
⁹DBS - direct broadcast satellite service
¹⁰tel - telephony
¹¹TTY - teletypewriter
¹²TVD - television distribution

¹³BOL - beginning of life
¹⁴EOL - end of life
¹⁵ss - summer solstice
¹⁶eq - autumnal equinox

International U
 about Alaska
 aska
 location of
 and Niles
 by
 into 1982

COMMUNICATIONS SATELLITES

FIXED		FOREIGN FIXED											
Eutelsat ECS	France Telecom	Telesat Canada Anik C	Telesat Canada Anik D	Australia Ausstat	India Insat	Japan CS*	RCA Satcom V-VIII	Western Union Westar IV-VI	Western Union Advanced Westar/TDRSS				
Mesh	Matra	Hughes	Spar Aerospace	Hughes	Ford Aerospace	Mitsubishi (Ford Aerospace contractor)	RCA Astroelectronics	Hughes	TRW				
5 planned (10 to 12 E)	2 planned (7, 10 W)	3 planned (112.5, 116, 109 W)	2 planned (104, 114 W)	3 planned (156, 160, 164 E)	2 planned (74, 94 E)	1 experimental active (135 E), 2 more planned (130, 135 E)	4 planned (132, 83 W, n.a., n.a.)	1 active (99 W), 2 more planned (123 W, n.a.)	5 planned, incl. 1 spare (41, 79, 91, 191 W)				
KU or CC Jan. 1983	KU Sept. 1983, Dec. 1983	CC Nov. 1982, April 1983, April 1984	CC Aug. 1982, Oct. 1985	KU or CC 1985	CC April 1982, July 1983	CC Dec 1977, TA Jan./Feb. 1983, Aug./Sept. 1983	CC Nov. 1982, March 1983, Dec. 1983, early 1984	CC Feb. 1982, June 1982, CC or KU late 1983	CC Jan. 1983, July 1983, Jan. 1984, May 1984				
Ariane	Ariane	shuttle or Thor Delta 3914	shuttle or Thor Delta 3910	Ariane, shuttle, or Thor Delta	Thor Delta 2914 or shuttle	Thor Delta 2914 N-2	Thor Delta 3910	Thor Delta 3910	shuttle				
regional tel., TVD	regional fixed tel., TVD	fixed tel., telegraph, data, TVD	fixed tel., telegraph, data, TVD	fixed tel., radio, data, TVD	fixed tel., TTY, meteorological data, TVD	fixed tel., TTY	fixed tel., TVD	fixed tel., telegraph, data, TVD	fixed tel., telegraph, TVD				
3-axis	3-axis	spin	spin	spin	3-axis	spin	3-axis	spin	3-axis				
1,030 at launch	1,142 at launch 653 in orbit BOL	1,090 at launch 567 in orbit BOL	635 in orbit BOL	600 in orbit approx.	1,152 at launch 600 in orbit	675 at launch 350 BOL	598 in orbit	584 in orbit	2,132 in orbit				
642 EOL	1,045 EOL	1,122 BOL ss	1,000 BOL ss	1,054 BOL ss	1,250 BOL 1,150 EOL ss	538 BOL eq 375 EOL ss	1,000 average	822 BOL 684 EOL	1,700 EOL				
Ku	C Ku	Ku	C Ku	C Ku	C S	C K	C	C	C Ku				
12 (9 activated)	6 6	16	24	15	4 2	2 6	24 all solid state	24	12	4			
80	40 120	36	54	36	45	36 0.2	180 to 200	130 to 200	34	36	36	225	
20	8.5 20	15	20	12, 30	4.5, 50	0.6	5	6	8.5	7.5	5.5	1.5, 30	
2 Rx 4 Tx	2 Rx 3 Tx	1 Rx 1 Tx	2 Rx 4 Tx	1 Rx 4 Tx	5 Rx 7 Tx	1 Rx 2 Tx	1 Rx 2 Tx	1 Rx 1 Tx	1 Rx 1 Tx	2 Rx 2 Tx	1 Rx 1 Tx	1 Rx 1 Tx	7 Rx 7 Tx
linear	circular	linear	linear	linear	linear	linear	circular	circular	circular	linear	linear	linear	circular and linear
-5.3	-13.6	6.5	3	-37.5 -27 -28	-3	-4.3 -3.4	-16.2	-8	-5	-5 Conus, AK -10 HI	-6 Conus -7.5 AK -10.9 HI, PR	-7 Conus -13 HI	-5 to 4.4
34.8 Eurobeam 40.8 spot	26.8 to 35.4	47.5	48	36	36 national 42 spot 47 spot	33 43.2	22.4	29.5 EOC	37 EOC	34 Conus 26 HI	34 Conus 31 AK 28.3 HI 27.2 PR	33 Conus 26 HI	42 to 50.3
-76.2 max -89.9 min	-70	-91	-80	n.a.	-90 to -75 (adjustable)	-90 to -72 (adjustable)	n.a.	-74	-80 Conus nom -84 Conus op -75 HI	-80 Conus -78.5 AK -75.1 HI, PR	-80 Conus -72 HI	-78 -75 -90	

300 to 3,000 MHz
 1,530 to 2,700 MHz
 2,500 to 2,700 MHz
 3,400 to 4,200 MHz
 4,900 to 4,700 MHz
 5,725 to 6,425 MHz

XI - 7,250 to 7,750 MHz
 7,900 to 8,400 MHz
 shf - 3 to 30 GHz
 Ku - 10.95 to 14.5 GHz
 Ka - 17.7 to 21.2 GHz
 K - 27.5 to 31.0 GHz

*Number of transponders = available communications channels, except when C and Ku bands share transponders, whereupon the number of simultaneously active transponders becomes less than the theoretical maximum obtained by channel summation; spares are not counted.

⁶Rx - receive
 Tx - transmit

⁷gl - global
 he - hemispheric
 zo - zonal
 es - east spot
 ws - west spot

⁸Conus
 AK
 ASEAN

U.S. FIXED								MILITARY				
GTE G-Star	Southern Pacific Communications Spacenet	Hughes Galaxy	AT&T Teletar 3	Satellite Business Systems SBS	American Satellite ASC	United States Satellite Systems Inc. USAT	USA DSCS II	USA DSCS III	NAZD III	Hughes Learnt		
RCA Astro-electronics	RCA Astro-electronics	Hughes	Hughes	Hughes	not yet chosen	not yet chosen	TRW	GE Space Division	Ford Aerospace	Hughes		
3 planned (103, 106, 97 or 119 W)	3 planned, incl. 1 spare (119, 70 W)	3 planned, incl. 1 spare (74, 135 W)	3 planned (95, 87, 128 W)	2 active (100, 97 W) and 1 planned (94 W)	3 planned, incl. 1 spare (122, 88 W)	3 planned, incl. 1 spare (88, 122 W)	14 active, 1 more planned	12 planned	3 active, 2 more planned	4 planned		
KU or CC April 1984, late 1984, early 1985	CC or KU 1984	CC or KU 1983 or 1984	CC 1983 or 1984	CC Nov. 1980, Sept. 1981, Nov. 1982	CC or KU Oct. 1985, March 1986	CC or KU 1985	CC 1971 to 1979, 1982 or 1983	CC 1982 or 1983	CC April 1976, Jan. 1977, Nov. 1978	CC 1984 or 1985		
Ariane, Thor Delta, or shuttle	Thor Delta 3920 or Ariane	Thor Delta 3920 or Ariane	Thor Delta 3920	Thor Delta 3910, shuttle	Thor Delta 3920, shuttle or Ariane	Thor Delta 3920, shuttle or Ariane	Titan III C	Titan III C or shuttle	Thor Delta 2914, 3913	shuttle		
fixed data and possibly DBS	fixed tel., telegraph, data, TVD	fixed tel., data, TVD	fixed tel., telegraph, data, TVD	fixed data, TVD	fixed TVD, voice, data	fixed tel., data, TVD	fixed/mobile military	fixed/mobile military	fixed military tel., TTY	mobile military		
3-axis	3-axis	spin	spin	spin	not yet determined	not yet determined	spin	3-axis	spin	spin		
670 in orbit 80L	670 in orbit	1,073 at launch 476 BOL	659 in orbit 80L	900 at launch 546 in orbit	1,270 at launch	668 in orbit 80L	538 80L	748 80L	349 80L	1,427 80L		
1,350 EOL eq	1,150	670 EOL	917 EOL 800 EOL	900 EOL	not yet determined	1,680 EOL eq	520 80L	1,100 80L 837 EOL	538 80L eq	1,210 EOL		
Ku	C, Ku	C	C	Ku	C, Ku	Ku	X	X	X	uhf, shf		
16	18	6	24	24	10	18	6	20	4	6	2	9
54	36	72	36	36	43	38, 72	72	43	410 total	395 total	17, 85	0.5, 0.025
20, 30	8.5, 18	16	8.5	5.5	20	7.5, 10	20	10, 20	20	10, 40	23	n.a.
3 Rx 3 Tx	2 Rx 2 Tx	1 Rx 1 Tx	1 Rx 3 Tx	1 Rx 4 Tx	1 Rx 1 Tx	multiple array	3 Rx 5 Tx	3	multiple array	2	2 Rx 2 Tx	
linear	linear	linear	linear	linear	linear	linear	linear	linear	circular	circular	circular	circular
-1.5 to -4.8	-5 to -4	-3 to -2	-7 edge of Conus	-5 edge of Conus	+2 to -2	-4 Conus -7 PR -9 AK, HI	-5 Conus -2 primary	-2 Conus -7 AK -4 HI	6.5, 20.2	-16 to -1	-14.1	-18 (uhf)
40 to 42	33 to 35 36 to 38	40 to 44	34.5	34 edge of Conus	40 to 43.7	34 Conus 36 Conus 27, 29 PR 28, 30 HI 31, 33 AK	39 Conus	40 Conus 35 to 38 AK, HI	28, 40	23-40	35, 29	28 (uhf) 26 (uhf) 16.5 (uhf)
n.a.	-80 to -79 or -86 to -85 (adj.)	-79 to -80 or -85 (adj.)	n.a.	n.a.	-82 (for G/T = -2)	-80 Conus -77 PR -75 AK -75 HI	-77 Conus	-78 to -80 nom	-84 -78	n.a.	n.a.	-157 to -113 (uhf)

*Values usually nominal
 †max - maximum
 ‡min - minimum
 §operational
 ¶n.a. - not available
 ††EOL - end of coverage
 †††COB - center of beam
 †††MCS - maritime communications subsystem for mobile L-band service to be leased by Inmarsat
 †††Must after firing apogee motor
 THIS CHART WAS COMPILED BY SATELLITE SYSTEMS ENGINEERING WASHINGTON, D.C. © 1987 ELECTRONIC M.G. GRAV...

LAUNCH VEHICLES FOR COMMUNICATIONS SATELLITES

JOSEPH B. MAHON

National Aeronautics and Space Administration

The United States currently maintains and operates a balanced family of space launch vehicles. These vehicles provide the capability to launch a wide variety of space missions such as planetary probes, meteorological and astronomical observatories, and communications satellites. The ability of current launch vehicles to launch communications satellites is a matter of considerable importance and is the subject of this paper.

CURRENT LAUNCH VEHICLES

The current civilian space launch vehicle inventory is listed below. The vehicles range in size from the Scout, intended for launching small (a few hundred pounds) spacecraft into Earth orbit, to the Atlas Centaur, designed to launch high energy planetary missions into escape trajectories. Of the vehicles shown, two are the primary launchers of communications satellites--the Delta and the Atlas Centaur. While the Titan IIIC has geosynchronous capability, it has not been used by commercial users to launch communications satellites.

Launch Vehicle	Low Earth Orbit/300 Inject'n Wt/Lb	Transfer Orbit Inject'n Wt/Lb	Weight in Geosync Orbit/Lb
Scout	450	-	1,380
Delta	6,600	2,750	1,380
Atlas-F	3,000	-	-
A/Centaur	11,500	5,050	2,500

Delta Launch Vehicle

The Delta was originally a combination of the Thor military ballistic missile and the upper two stages of the Navy Vanguard launch vehicle. Over its life, all three stages have evolved and changed. The vehicle is currently being offered with two third stages for

selection by the user--an updated version of the Thiokol solid motor (Star 37) or the newly developed Star 48 motor. Two versions of the Castor motor are available for strapping to the core vehicle to augment the thrust developed by the first stage.

The Delta launch vehicle has been operational since 1960 and has been used for over 160 space launches. It is eight feet in diameter and about 115 feet tall standing on the pad ready for launch. The Delta is the most frequently used U.S. launch vehicle and has launched most of the commercial communications satellites to date. Its performance and cost have made it an attractive vehicle for first generation communications satellites.

NASA plans to provide Delta vehicles as long as they are needed during the transition period to the Space Shuttle. For the present planning, six launches are planned in Fiscal Year 1982, seven in Fiscal Year 1983, nine in Fiscal Year 1984, and nine in Fiscal Year 1985. I have not included projections for Delta usage well into 1985 because the lead time for vehicle fabrication permits delaying the decision to proceed on these vehicles for about a year. It does appear that the demand for Delta will continue into 1986.

Atlas Centaur Launch Vehicle

The Atlas Centaur is an all-liquid propellant, two-stage launch vehicle. The first stage is a modification of the early Atlas ICBM, stretched and updated to provide greater performance. The second stage is the Centaur--NASA's first operational stage using hydrogen/oxygen propellants.

The Atlas Centaur has been operational since about 1965 and has been used for over 60 launches. It is ten feet in diameter and about 130 feet tall. It was first used to launch the

Surveyor spacecraft which soft-landed on the Moon. The Atlas Centaur has subsequently been used for launching a variety of missions, including planetary probes and larger, more sophisticated second-generation communications satellites. It is currently being used to launch the INTELSAT-V and VA series of spacecraft, as well as the Navy Fleet Communications satellites.

NASA planning for Atlas Centaur includes launches through 1985 for INTELSAT-VA, and through 1986 for FITSATCOM. It could be available on a three-year lead time notification to prospective users for larger communications satellites, including the direct broadcast type.

COMMUNICATIONS SATELLITE ORBITS

The U.S. and other Western satellite developers have preferred to place communications satellites in the geostationary orbit where the spacecraft remains stationary with respect to the Earth, directly above a point on the equator. This result is achieved by a unique combination of orbital period, eccentricity, and inclination--the orbital period of the spacecraft being 24 hours equal to the Earth's rotational period; the orbital eccentricity being zero, resulting in a constant spacecraft velocity throughout the orbit; and the orbital inclination being zero, meaning the orbital plane is in the plane of the Earth's equator.

The advantage of the geostationary orbit is the constant position of the satellite with respect to ground stations, which greatly simplifies the operation of the ground stations. However, for ground stations at high latitudes, the satellite in the geosynchronous orbit is near the horizon, a situation less than ideal for communications links. Some communications, therefore, employ an inclined elliptical orbit with a period of 12 hours. While this orbit does not allow continuous communications between a ground station and a satellite, the orbit geometry causes the spacecraft to hover above a specific ground location for a substantial part of the orbit.

TYPICAL LAUNCH TRAJECTORY

The delivery of a communications

satellite to the popular geostationary orbit occurs in four steps or phases: launch or ascent, parking orbit, transfer orbit, and orbital insertion.

Using the Delta 3920/PAM (a three-stage Delta vehicle with nine strap-on Castor motors) to illustrate these phases, the launch profile is described. The profile for Atlas Centaur would be generally similar. In either of these cases, the launch would be from the Eastern Space and Missile Center in Florida.

Ascent begins at vehicle lift-off when the first stage main engine and six of the nine Castor solid motors are ignited. Only six are ignited to keep the vehicle accelerations down. Following the burn of the six Castors, the remaining three are ignited in flight. The entire sequence of Castor motor burns takes about two minutes, at the end of which the vehicle has risen to a height of 27 nautical miles and has attained a velocity of approximately 8000 feet per second (5400 miles per hour). From this point, the first stage main engine propulsion system continues operating, reaching cut-off at an altitude of 63 nautical miles and a velocity of about 18,500 feet/sec (12,600 miles/hour). The remaining energy to achieve orbit is supplied by the second stage, cut-off occurring at 543 seconds after lift-off.

For geostationary orbits, the spacecraft mass that can be delivered is maximized by injecting it into the transfer orbit at an equatorial crossing. Therefore, the Delta second stage (with partial propellant load remaining), the third stage (payload assist module), and the spacecraft must coast in the parking orbit until the proper time for the injection burn. The injection burn is normally completed at the first equatorial crossing; the second and third stages are both used for this burn, which accelerates the spacecraft to a velocity of 33,600 ft/sec (22,800 miles/hour).

The transfer injection burn occurs at an equatorial crossing, i.e., at a node of the parking orbit, which places the spacecraft into a transfer orbit with apogee at geosynchronous altitudes. To achieve geostationary orbit, another velocity impulse must be applied at the apogee of the transfer orbit to remove the orbital inclination due to

the launch site latitude and to circularize the final orbit. This final velocity increment can be supplied by the launch vehicle upper stage or by the spacecraft. The current practice for Delta and Atlas Centaur launches of communications satellites is for the spacecraft to insert itself into final orbit. To do this, the spacecraft must include a sizeable propulsion system, typically, a solid propellant motor. As a rule of thumb, the mass of the apogee motor will be approximately the same as the mass of the rest of the communications satellite. Thus, for an estimate of the final mass in geostationary orbit, the quoted geosynchronous transfer injection mass for a given launch vehicle should be divided by two.

HISTORICAL AND PROJECTED COMMUNICATIONS SATELLITES

The extent of past and projected communications satellites is illustrated below. The launches have been grouped into four time periods and two mission classes. The class labeled International includes INTELSATs and early experimental satellites, such as Early Bird and Syncoms; the Regional class includes the domestic communications satellites (i.e., Westar, Marisat) and regional national systems, such as the ANIK or Palapa series. The four launch periods are five year intervals to reflect the early period (1965-1970), two mid periods to reflect launch levels (1971-1976 and 1977-1981) and, finally, 1982 and beyond. Not included in this projection are launches of communications satellites by the Space Shuttle. As can be seen, the pace is expected to continue and increase in the future.

Mission Class	Years			
	65-70	71-76	77-81	82-85
International	13	13	9	10
Regional	0	10	18	24

Director, Expendable Launch Vehicles,
National Aeronautics and Space Administration,
Washington, DC 20546

Director of NASA's Expendable Launch Vehicles Program. Responsible for NASA's family of expendable launch vehicles, completing nearly 200 successful space launches of scientific satellites and observatories, lunar and planetary probes and satellites, as well as communications satellites for commercial organizations.

Previous experience included employment by the Navy Department as Systems Engineer for the Polaris missile and Senior Project Engineer of the Sparrow air-to-air guided missile.

Holds a B.S. in Mechanical Engineering from Catholic University.

Earned NASA Distinguished Service Medal for efforts in Launch Vehicles, NASA Exceptional Service Medal for work on the Agena Program which resulted in the first U.S. spacecraft landing on the Moon, and Secretary of Navy Certificate of Commendation for work on the Polaris missile.

ATLAS AND CENTAUR ADAPTATION AND EVOLUTION—27 YEARS AND COUNTING

H. M. Bonesteel

Atlas/Centaur Program Director,
General Dynamics Convair Division

ABSTRACT

The Atlas and Centaur launch vehicles have evolved and adapted since 1955 to provide the spacecraft community with a highly reliable launch system. The production and launch events of these vehicles are described, the environment provided to a spacecraft is detailed, and the payload performance and accuracy of the launch vehicle system are presented.

INTRODUCTION

There is a story about two astronauts sitting atop their launch vehicle somewhat apprehensively discussing their fate being in the hands of a "stack of low-bid" hardware.

No doubt a number of you have, at times, had some of the same misgivings as your "electronic astronauts" waited to be propelled into space. Perhaps you would have been more comfortable had the equipment been carried aboard a vehicle with a little more "heredity" or "lineage".

Two vehicles that have always been extolled as examples of durable and long-term production runs have been the innovative Ford Model T and the venerable DC-3. The Model T was in continuous production from 1909 to 1927 and the DC-3 from 1934 until 1945 (people seem to forget the A4 Skyhawk that was built for 26 years). The reasons these products were produced for such a long time were:

1. They were good, reliable products.
2. They evolved and improved to meet the needs of their users.

There is another vehicle that meets those same criteria and has been in continuous production since 1955 -- longer than the Ford, the Gooney, or the Skyhawk -- and that is the Atlas (Figure 1). From its beginning as an intercontinental ballistic

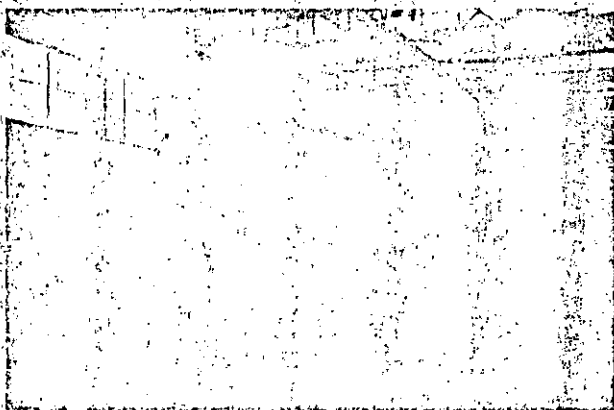


Figure 1. Atlas and tank, after welding.

missile over a quarter century ago, until the present day, it has evolved, improved, and adapted to serve the United States Space Program like no other vehicle. From John Glenn to Voyager, Atlas, and its heir, the Centaur, have provided that "stack of low-bid" hardware for almost 500 launches.

ATLAS

From its beginning in 1955, Atlas has progressed through the years until today there exists a "family" of vehicles still expanding in capability and reliability.

Figure 2 is today's "family portrait." The three vehicles on the right, together with other versions, are being considered in advanced studies as we adapt to survive in the Shuttle era.

CENTAUR

The "youngest" in the Convair launch vehicle stable is the Centaur (Figure 3). The world's first liquid hydrogen launch vehicle, the Centaur has been in continuous production since 1960 (only 22 years). Even a quick examination of the Centaur will show its family resemblance to Atlas. This vehicle developed directly from the Atlas technology of the late 1950s, but it, too, has been shaped and reshaped to meet the needs of the spacecraft community. Today it is being improved again to provide even more capability for the INTELSAT-VA spacecraft to be launched in 1984.

ATLAS AND CENTAUR

Atlas and Centaur have faced the trials that all new vehicles seem to have to endure. (Table 1 indicates that launch vehicles can expect four failures out of the first ten tries. This appears to have been a common pattern with the exception of the Saturn

Table 1. New launch vehicles require many flights to achieve high reliability.

	Early Mission Success (%)			Total Flights	Current Operational Reliability (%)
	First 5	First 10	First 15		
Lower Stages					
Thor (space launches)	60	70	80	500	96
Atlas (space launches)	60	70	68	466	96 (SLV)
Titan III	100	100	100	124	99
Lower Stage Average	73	80	82	358	97
Upper Stages					
Agona	60	70	73	352	96
Centaur	60	70	73	68	100 (D-1)
Translago	80	60	73	37	92
Upper Stage Average	67	67	73	149	96
Vehicle average (lower X upper stage)	49	54	60	N/A	93

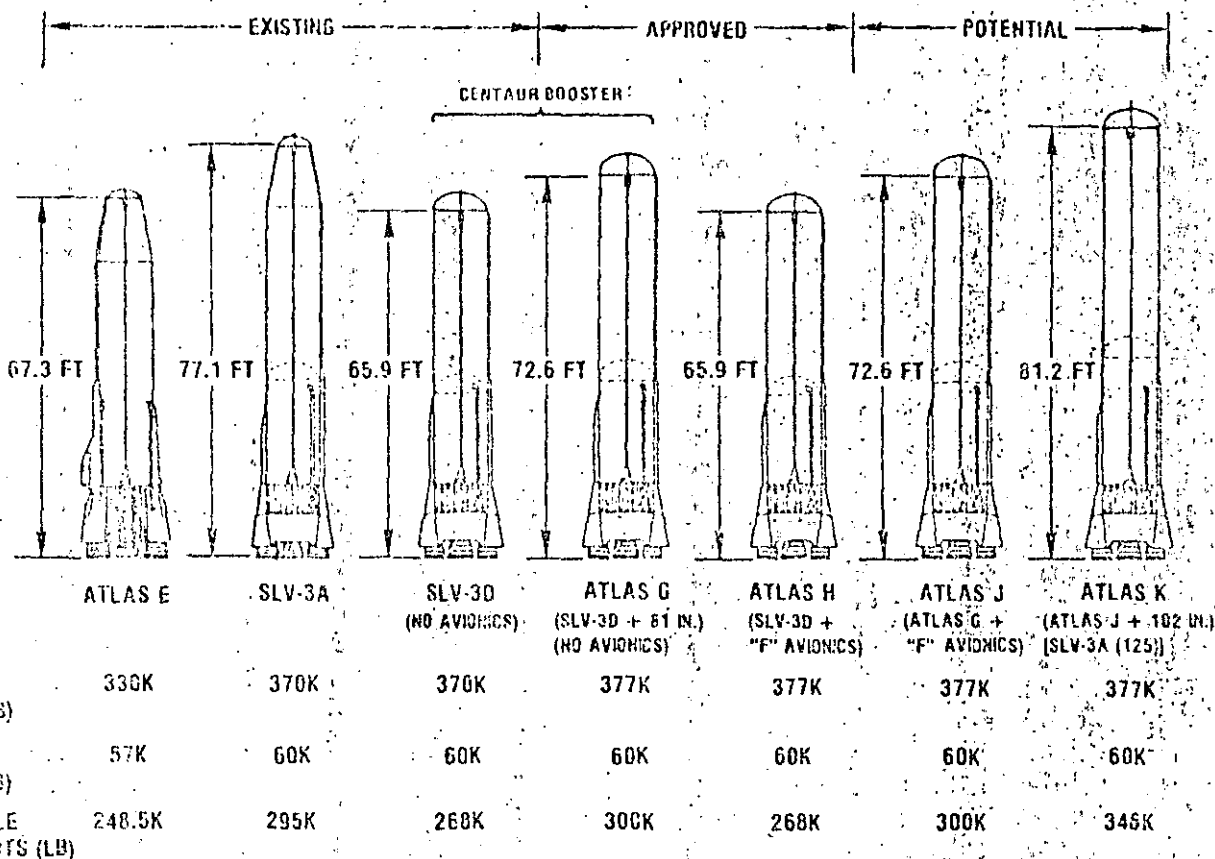


Figure 2. Atlas vehicle family.

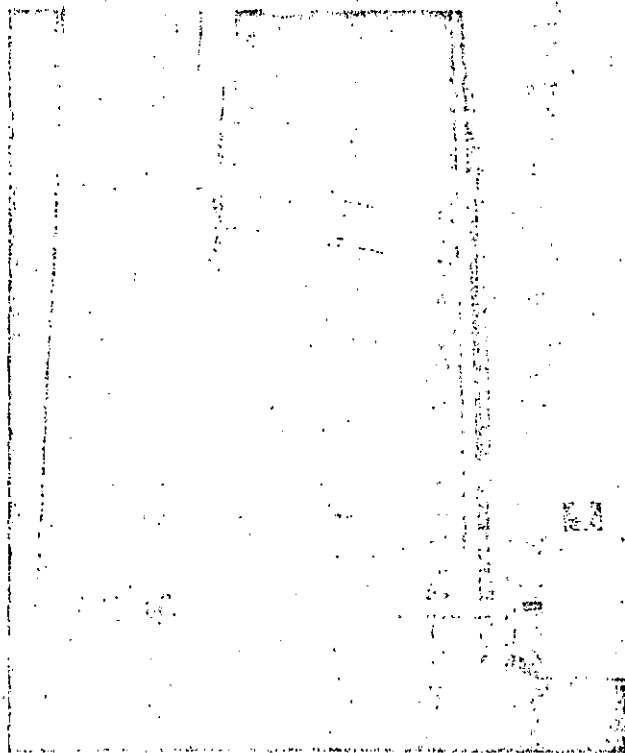


Figure 3. Centaur vehicle in hoist for welding operation.

series (and hopefully the Shuttle). Together, Atlas and Centaur have provided 25 years of successful launch vehicle experience (Figure 4).

ATLAS & CENTAUR — HOW THEY ARE BUILT

The Atlas and Centaur vehicles are unique. They are fabricated (Figure 5) of thin (0.014 in. — 0.041 in.) stainless steel skins with no (that's none) internal supporting structure. The skins are welded together to provide sealed tanks for holding the liquid oxygen (LO₂) and kerosene (RP-1) for the Atlas and LO₂ and Liquid Hydrogen (LH₂) for the Centaur. Like a football or basketball, the strength and stability of the tanks are maintained by pressurizing the tanks at all times and utilizing sensing systems to prevent undesired deflation.

A skin stringer and fiberglass section encloses the Rocketdyne booster engines at the aft end of Atlas while a similar skin stringer structure is used to connect the Centaur to the Atlas and provide a cover for the Pratt & Whitney Centaur engines. Insulation panels on the sides of the Centaur prevent the formation of liquid air when the vehicle is loaded with liquid hydrogen and a fiberglass and aluminum nose fairing provides payload accommodations. The total assembly is finished in San Diego and air shipped to Cape Canaveral for launch from Complex 36.

LAUNCH-SITE OPERATIONS

At the Cape, all spacecraft operations are essentially independent of the launch vehicle preparations prior to encapsulation into the nose fairing for installation on the launch vehicle (Figure 6). Subsequent to an integrated countdown, the

Atlas/Centaur		Titan/Centaur	
Payloads	(53)	Payloads	(7)
Test Flight	(8)	Test Flight	
Surveyor	(7)	Helios A	
ATS	(2)	Helios B	
OAO	(3)	Viking A	
Mariner Mars	(4)	Viking B	
Intelsat IV	(6)	Voyager 1	
Intelsat IVA	(6)	Voyager 2	
Pioneer F	(1)		
Pioneer G	(1)		
MVM	(1)		
Comstar	(4)		
HEAO A	(1)		
HEAO B	(1)		
HEAO C	(1)		
Ellisatom	(5)		
Pioneer Venus	(2)		
Intelsat V	(4)		
		Atlas	
		467	

Figure 4. Launches -- 1957-1982.

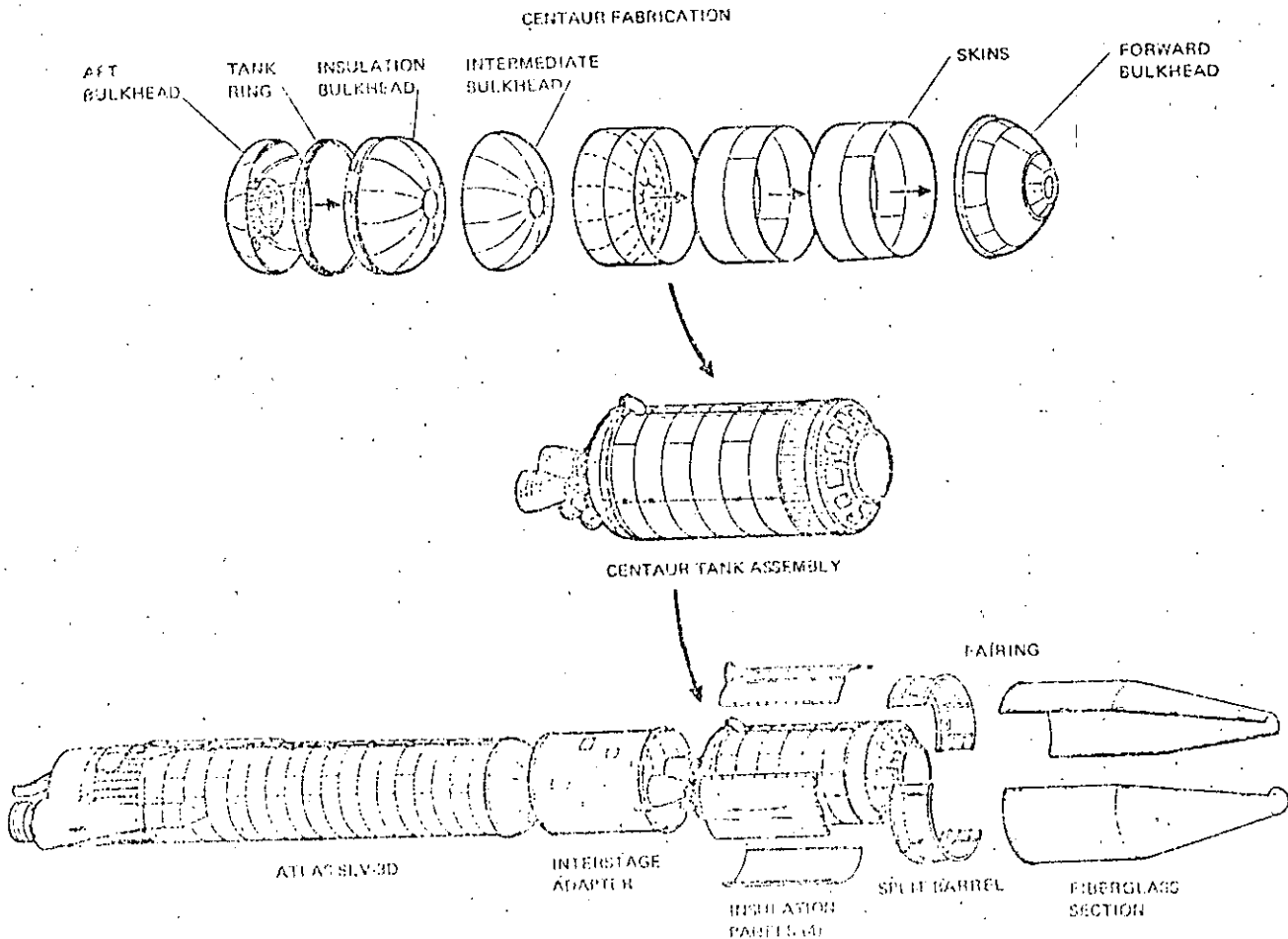


Figure 5. Fabrication sequence.

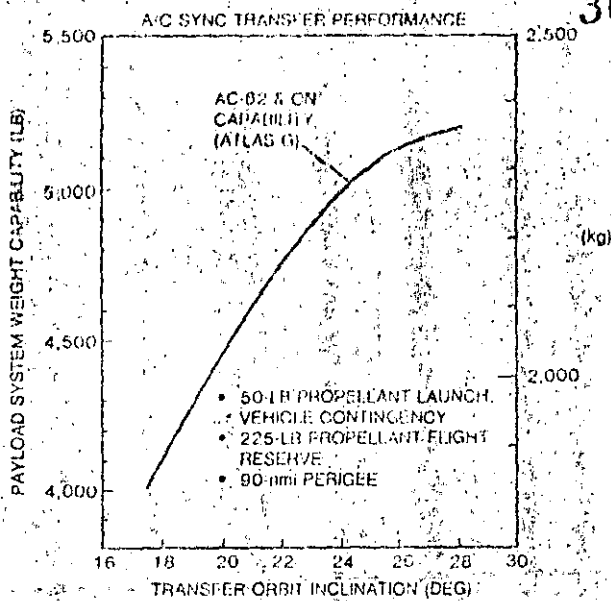


Figure 8. Synchronous transfer performance capability for Atlas/Centaur vehicles.

vehicle ensures an excellent chance of a successful mission. The demonstrated reliability of the Atlas/Centaur over the last five years has been 100%.

Table 2. Operational reliability.

Atlas/Centaur (last 36 flights)	94%
Titan/Centaur (six flights)	100%
Centaur stage (last 40 trials)	100%

WHAT IS SUPPLIED FOR THE PAYLOAD?

The Atlas/Centaur provides general space and services for each of the spacecraft it launches. Unique requirements are provided on a mission-by-mission basis, but these unique requirements usually result in only minor modifications.

Figure 9 shows the space available within the Centaur nose fairing that is usable by a spacecraft. Usually payload dynamic analyses are performed in order to explicitly define this envelope for a specific application. Access doors are also provided for unique items.

For past payloads, Convair has provided structural adapters for mounting spacecraft to the Centaur forward equipment module. Normally, the spacecraft provides its own separation plane above the equipment module since there is no standard separation device designed for the module. Figure 10 shows the size and shape of these adapters.

Electrical and signal interfaces to each spacecraft are normally provided as shown in Figure 11. These standard services are usually adequate for most spacecraft but we have provided more, or less, in the past and the unique requirements of a particular spacecraft are usually easy to provide. We also have available, remote multiplexer units to provide for some spacecraft telemetry during ascent.

WHAT DOES THE SPACECRAFT HAVE TO ENDURE?

Many people say that the space environment is more benign than the things the spacecraft has to endure prior to launch and during its ascent. This is probably true, but if they are well known, then they can be accommodated. The pad environment and ascent conditions for Atlas/Centaur have varied only slightly over the last decade.

Thermal Conditions.

On the launch stand a payload gas conditioning system provides dry air or gaseous nitrogen to the spacecraft at the required temperature, dew point, and flow rate. The flow paths are shown in Figure 12.

During the ascent the internal temperature of the fairing is very stable (Figure 13). The jettison point for the fairing is calculated during ascent and is usually set by performance requirements combined with spacecraft allowables for dynamic pressure. The pressure profile within the fairing during this same period is shown in Figure 14.

Structural Conditions.

Figure 15 shows the axial load factors for a 5200-lb payload during the ascent portion of the Atlas/Centaur flight. In addi-

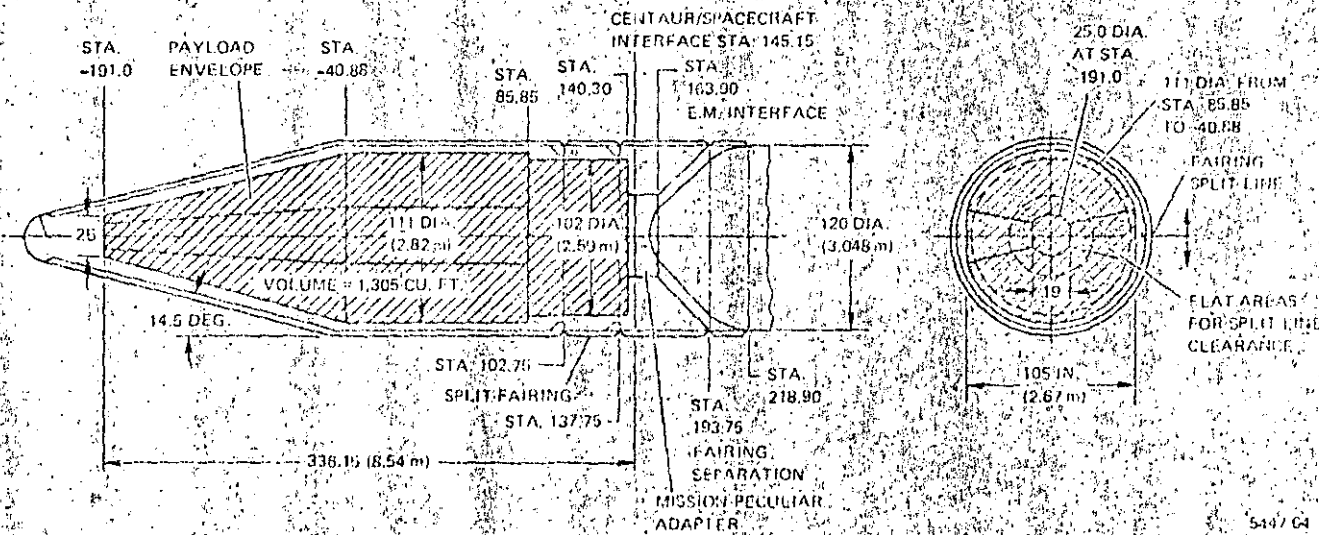


Figure 9. Centaur nose fairing useable space.

vehicle begins its launch phase when all booster engines are ignited and liftoff occurs (Figure 7).

FLIGHT PROFILE

At approximately 2.5 minutes into flight, the booster section is jettisoned and the sustainer phase continues until Atlas propellants are depleted. When Centaur engines are ignited and the nose fairing is jettisoned, the vehicle continues on to a parking orbit phase of variable length depending on payload. The Centaur engines burn again to inject the payload into a geosynchronous transfer orbit, and the payload is separated. Circularization of the orbit is achieved by the use of an apogee motor on the payload.

PAYLOAD CAPABILITY

Figure 8 presents the synchronous transfer performance capability for the Atlas/Centaur vehicles now in production. Note that the transfer orbit inclination has a significant effect on the attainable weight. Those conditions noted on the figure are critical "ground rules" utilized to develop the curves and shown as examples of some of the important parameters.

BUT WILL IT MAKE IT?

Atlas/Centaur reliability cannot claim a "certainty" comparable to "death and taxes," but its success record is impressive. Table 2 shows that launching on an Atlas/Centaur

Figure 6. Current Centaur fairing (for Intelsat IV).

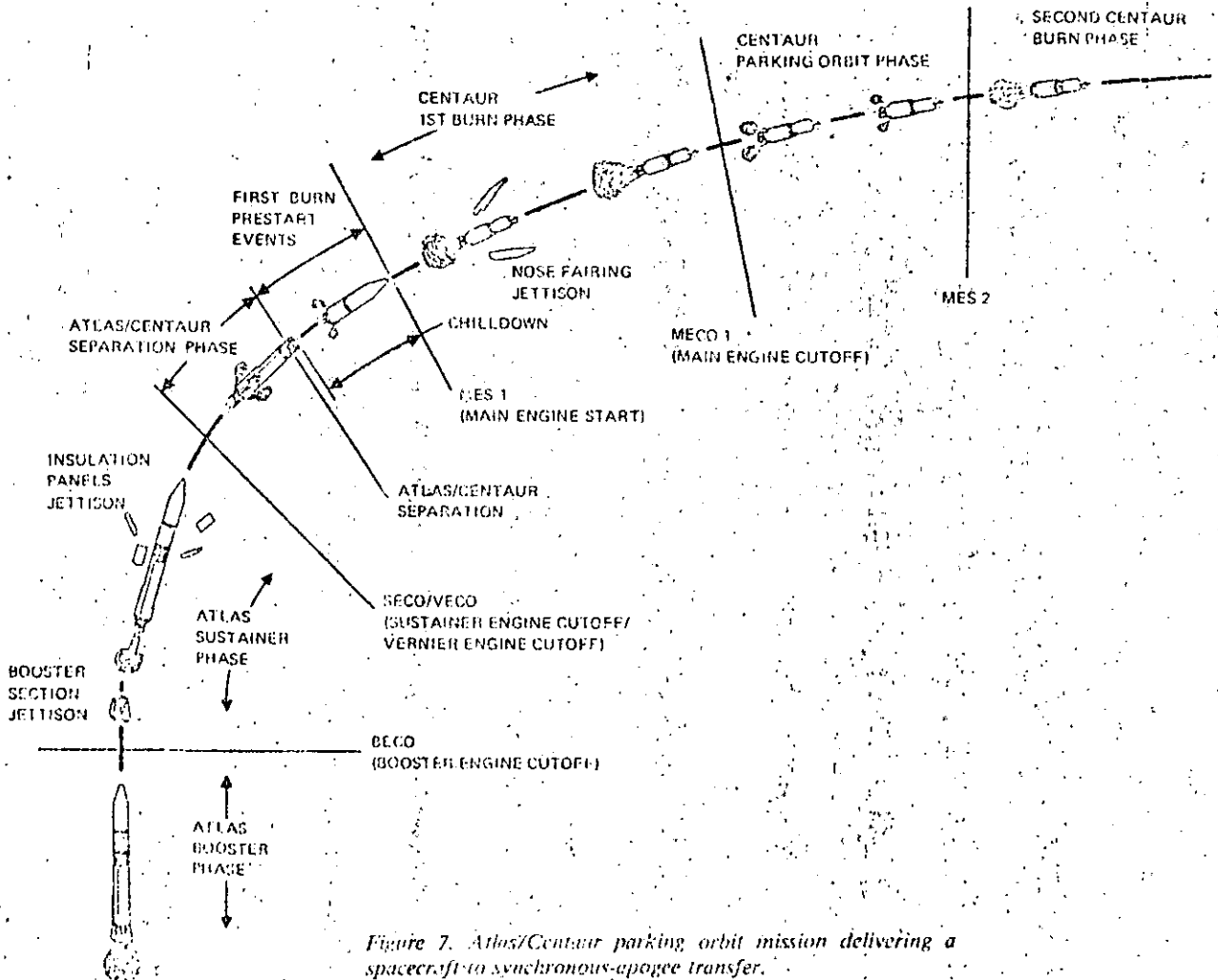
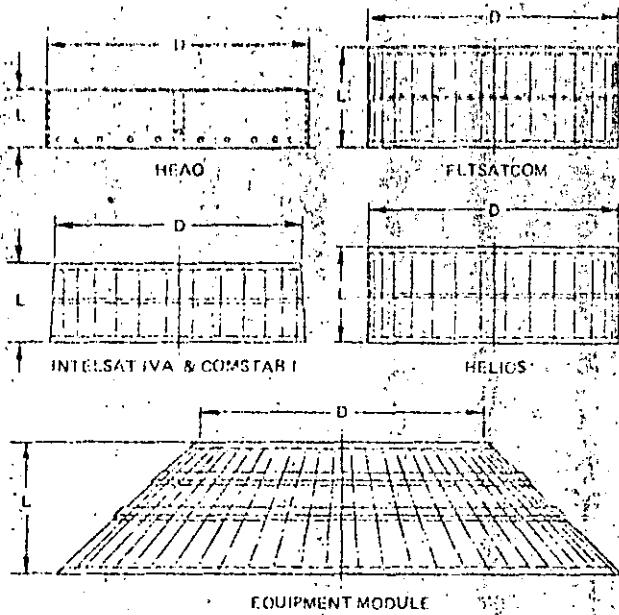


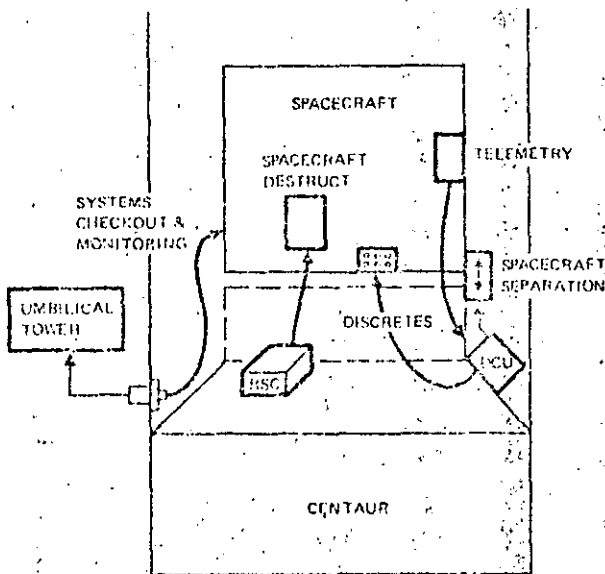
Figure 7. Atlas/Centaur parking orbit mission delivering a spacecraft to synchronous-apogee transfer.



SPACECRAFT ADAPTER	LENGTH L (IN.)	BOLT CIRCLE DIAMETER D (IN.)	BOLT DIAMETER (IN.)	NO. OF BOLTS
HEAD	13.00	61.250	1/4	98
FLTSATCOM	23.60	60.500	1/4	91
INTELSAT IVA COMSTAR I	18.75	58.950	1/4	91
HELIOS	23.50	58.630	3/16	68
E/M INTERFACE	30.00	62.010	1/4	121

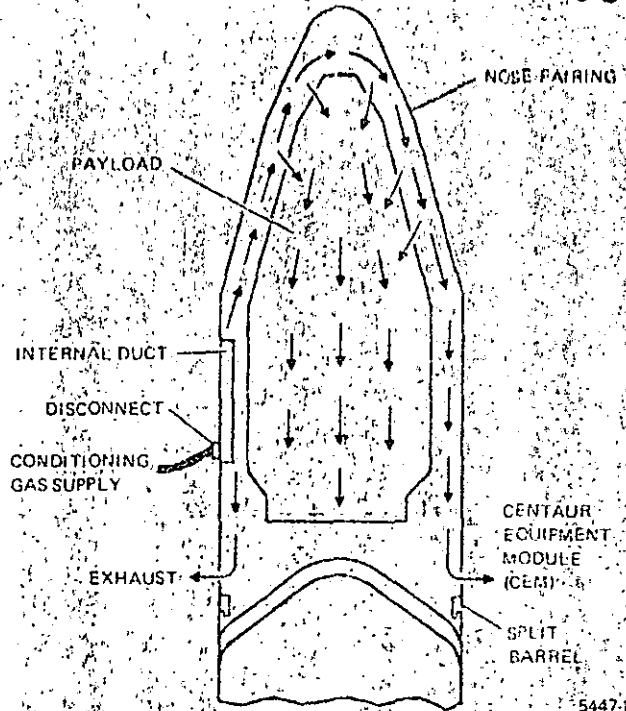
5447-66

Figure 10. Equipment module interface.



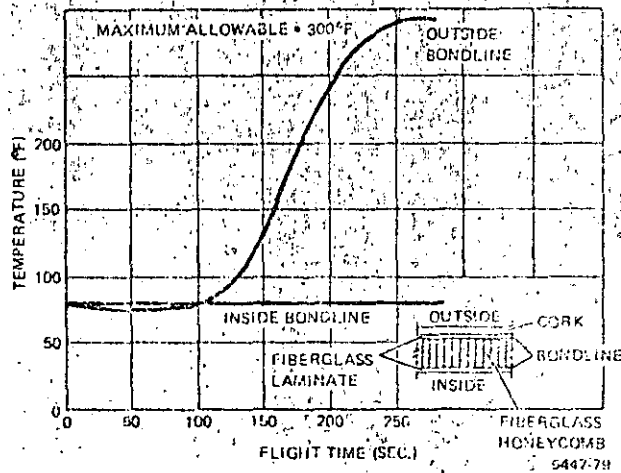
5447-68

Figure 11. Typical electrical interfaces.



5447-86

Figure 12. Payload gas conditioning system.



5447-79

Figure 13. Fairing maximum bondline/temperature predictions (conical portion).

tion to these "steady state" accelerations, various transients apply equivalent accelerations of 1-2 g to the center of gravity of the spacecraft both laterally and longitudinally. Actual values are very sensitive to individual payload design with some tendency to decrease as payload weight increases.

Dynamic loadings on the spacecraft during ascent are a combination of vibration, acoustics and shock. Figure 16 shows a very general test level which would vary for different spacecraft. Each spacecraft is usually individually analyzed to determine its peculiar characteristics.

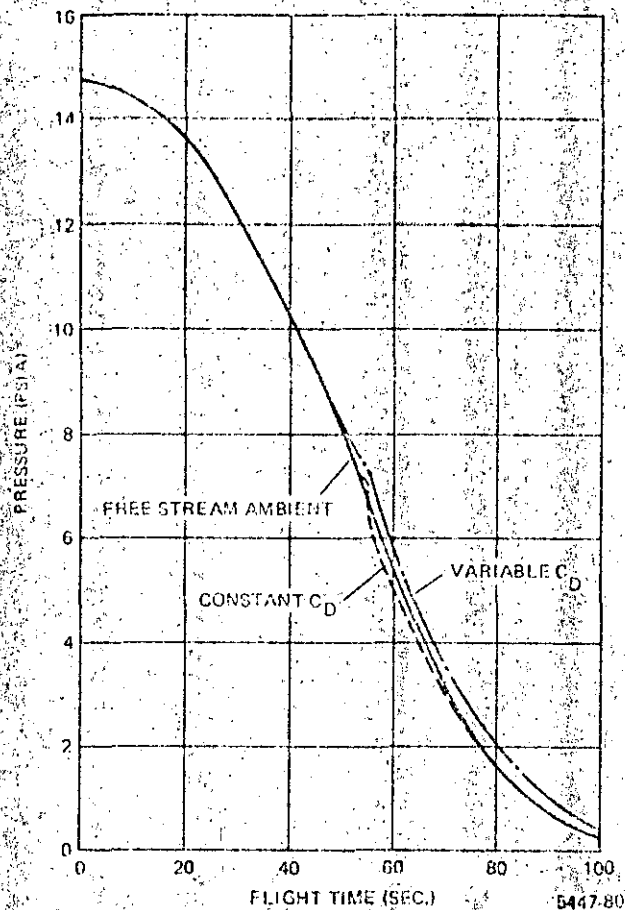


Figure 14. Typical firing pressures.

Peaks of acoustic noise occur at launch and in the transonic portion of ascent and payload components should be capable of functioning during one minute of exposure to the acoustic spectrum portrayed in Figure 17.

Although shock events occur upon jettison of nose fairing and insulation panels due to pyrotechnic devices, the major payload shocks are normally encountered during the self-generated separation event.

WHAT DOES THE PAYLOAD GET FOR ITS TROUBLE?

One of the hallmarks of the Centaur vehicle is accuracy. The combination of the highly accurate inertial guidance system with flexible guidance software has enabled the Centaur to achieve precise injection conditions for a complete spectrum of missions, both interplanetary and earth-centered. Figures 18 and 19 demonstrate that Centaur not only meets the mission requirements but exceeds them by a substantial margin.

SUMMARY

The Atlas and Centaur vehicles have adapted and evolved over the years to supply a portion of the launch capability needed by the world's spacecraft community (Figure 20). This

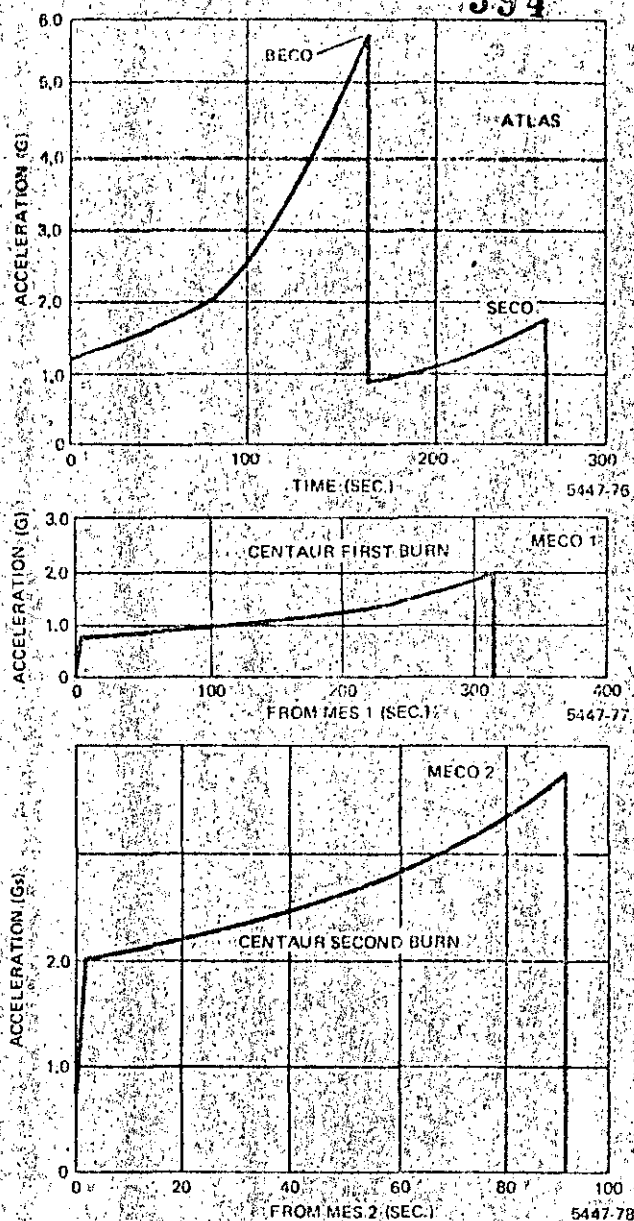


Figure 15. Axial load factors for Atlas/Centaur flight (5,200-lb payload).

process has not been without some temporary setbacks even though every change was critically evaluated for what its effect would be on the launch reliability of the vehicle. Even today, under the direction of the NASA Lewis Research Center, the capability of the Atlas/Centaur is being expanded to meet current requirements and will, in the future, provide the same high-performance, reliable launch services that have enabled it to be today — 27 years and counting.

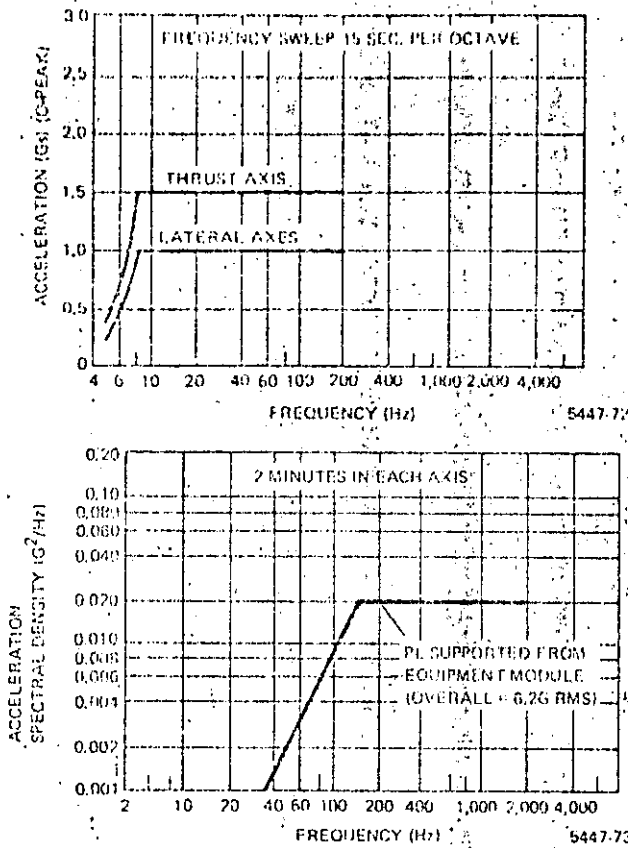


Figure 16. Recommended sinusoidal vibration environment and expected random vibration spectrum.

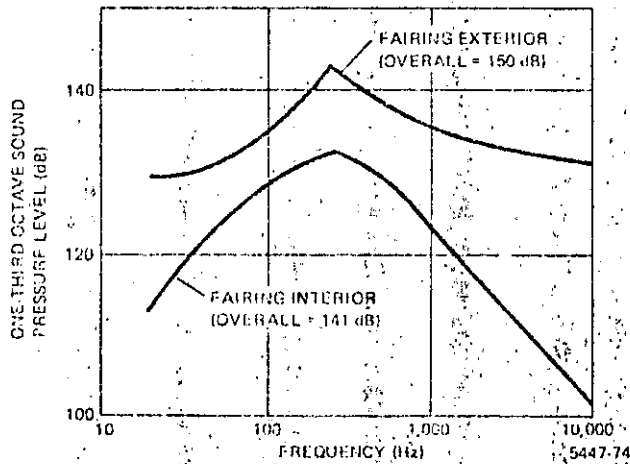


Figure 17. Expected acoustic environment.

	Transfer orbit (Centaur 2nd burn)		Final Orbit (Centaur 3rd burn)
	Flight Data	Guidance System 3a	Guidance System 3a
Perigee (nmi)	0.83	1.3	—
Apogee (nmi)	34.1	63.3	—
Apogee Minus Perigee (nmi)	—	—	306
Inclination (deg)	0.000	0.022	0.29
Period (min)	1.21	2.25	11

* AC-54; Intelsat
• Titan/Centaur

Figure 18. Typical accuracy for synchronous orbit.

	Mission Requirement	Flight Data	Guidance System 3a
Relative Node (deg)	0.5	0.05	0.14
Circularity (nmi)	5.0	2.8	3.96
Inclination (deg)	0.1	0.003	0.037

Figure 19. Typical accuracy for near-earth orbit (HEAO A 290 nmi data). Launch mode: direct ascent.

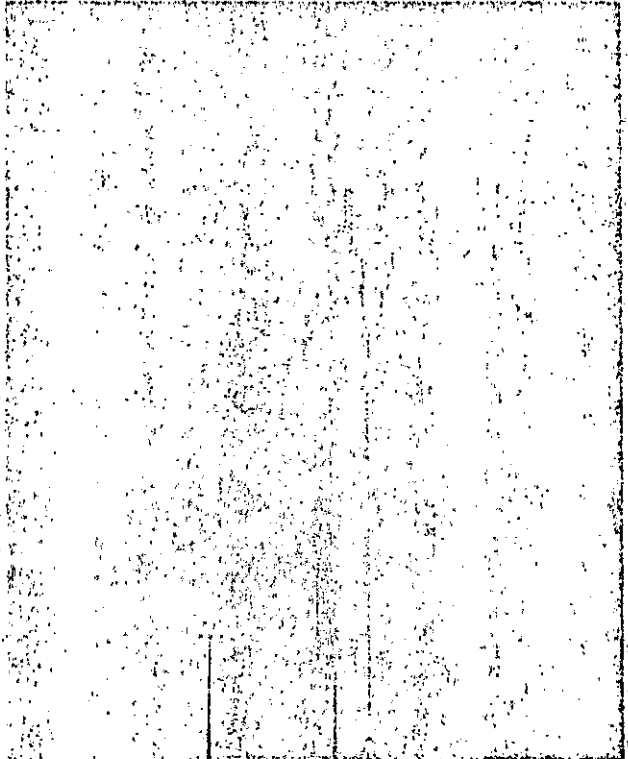


Figure 20. Communication satellite launch by Atlas/Centaur.

SPACE TRANSPORTATION SYSTEMS UTILIZATION

CHESTER M. LEE
DIRECTOR, STS UTILIZATION

NASA HEADQUARTERS

ABSTRACT

It is planned that the Space Transportation System (STS) will become operational in late 1982 after the successful completion of four test flights. To date, two flights were successful with a third scheduled for late March 1982.

The successful utilization of the STS will depend upon reducing costs and the price of sending cargo and ultimately people into space. As this begins to take effect, more and more flights will occur. The Space Shuttle can be reflown up to 100 times and unlike the expendable launch vehicles, offers a tremendous opportunity for developing a cost reduction to space utilization.

This presentation will focus on the Space Shuttle system, its components and what the mission profile and launch sequence will entail. Also included will be the types of payloads carried on the Shuttle, the upper stages, a discussion of the current NASA Space Shuttle manifest and a preview of the Ariane competition.

CHART 1 - A general overview of the Space Transportation System which includes the Space Shuttle, Spacelab, IUS, SSUS-A, and SSUS-D configurations.

CHART 2 - The general dimensions and performance levels of the Space Shuttle reveal its potential capabilities.



CHART 3 - The mission profile from payload integration, liftoff, orbital operations, re-entry and landing.



CHART 4 - An overview of the NASA Kennedy Space Center Shuttle facilities, including the facilities which will be used to checkout, integrate, and launch the payloads on the Shuttle.

KSC SHUTTLE FACILITIES



CHART 5 - The Shuttle mission priorities which specify first-come, first-serve.

MISSION PRIORITIES

- GENERAL POLICY
 - TO ACCOMMODATE USER REQUIREMENTS AS CLOSE AS POSSIBLE ON A FIRST-COME, FIRST-SERVED BASIS
- IN THE EVENT OF CONFLICTING REQUIREMENTS, THE PRIORITIES TO BE FOLLOWED ARE:
 - SPACE PROGRAMS REQUIRING URGENT STS SUPPORT TO MAINTAIN NATIONAL SECURITY MISSION CAPABILITIES
 - COMMERCIAL & FOREIGN
 - NASA PAYLOADS

CHART 6 - A listing of the Space Transportation products and services.

SPACE TRANSPORTATION PRODUCTS AND SERVICES

- LAUNCH AND ORBIT SERVICES
- PAYLOAD HANDLING AND CHECKOUT
- PAYLOAD OPERATORS SUPPORT
- CREW TRAINING
- SPARES AND LOGISTICS
- EXPENDABLE LAUNCH VEHICLES
- SHUTTLE EXPENDABLES
- OPERATIONAL UPPER STAGES
- SPACELAB AND SUPPORT EQUIPMENT
- RATE FACILITIES

CHART 7 - A pictorial view of the Space Shuttle manifest.



CHART 8 - A listing of the domestic and the foreign payloads booked on the Shuttle and Expendable Launch Vehicles (ELV).

OFFICE OF SPACE TRANSPORTATION OPERATIONS SHUTTLE/ELV REIMBURSABLE USERS (EXCEPT OTHER U.S. GOVERNMENT AND USG)									
AT&T LONG LINES	4	2	2	WEST GERMANY (BMFT)	1	1	1	1	1
BTE SATELLITE CORP.	1	2	2	FRG (WGS)	1	1	1	1	1
BUGH'S COMM. INC.	0	0	0	TELESAT CANADA	2	1	1	1	1
WASH'S COMM. SERVICES, INC.	1	1	1	INDIA	2	1	1	1	1
SOUTHERN PACIFIC COMM.	3	1	1	INDONESIA	2	1	1	1	1
SATELLITE BUSINESS SYSTEMS	2	2	2	ASIAN SATELLITE COMM. ORG.	2	1	1	1	1
SPACECOM	4	1	1	AUSTRALIA	2	1	1	1	1
SATELLITE TELEVISION CORP.	6	1	1	COLOMBIA	4	2	2	2	2
COMSAT GENERAL CORP.	4	1	1	ITALY	1	1	1	1	1
RCA AMERICAN COMM. INC.	16	3	3	JAPAN (SHARED SPACELAB)	1	1	1	1	1
WESTERN UNION TELEGRAPH CO. INC.	4	2	2	UNITED KINGDOM	3	1	1	1	1
U.S. SATELLITE SYSTEMS	1	1	1	NATO	2	1	1	1	1
AMERICAN SATELLITE CO.	3	1	1	FRANCE - TELE-LUXEMBOURG	3	1	1	1	1
				WELLSAT	20	9	9	9	9
				CRS (SHARED SPACELAB)	13	1	1	1	1
				SPAZA	2	1	1	1	1
				BRITISH AEROSPACE	2	1	1	1	1
TOTALS	62	29	32	TOTALS	58	9	42	7	7

CHART 10 - The U.S./Foreign Geosynchronous Communications Traffic projected to the year 2000 and the increasing number of transponders on-orbit in the out years.

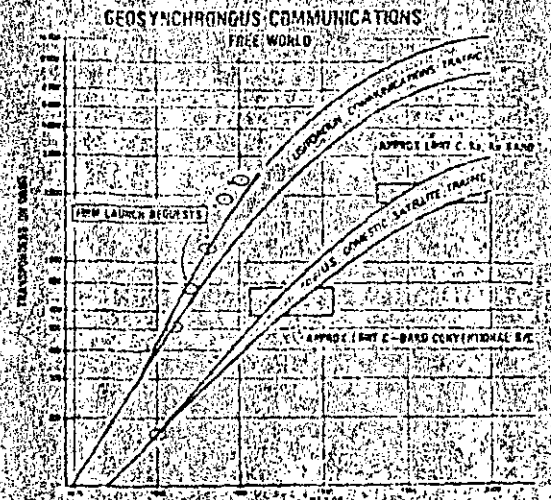


CHART 9 - A cost comparison between the STS and the ELV.

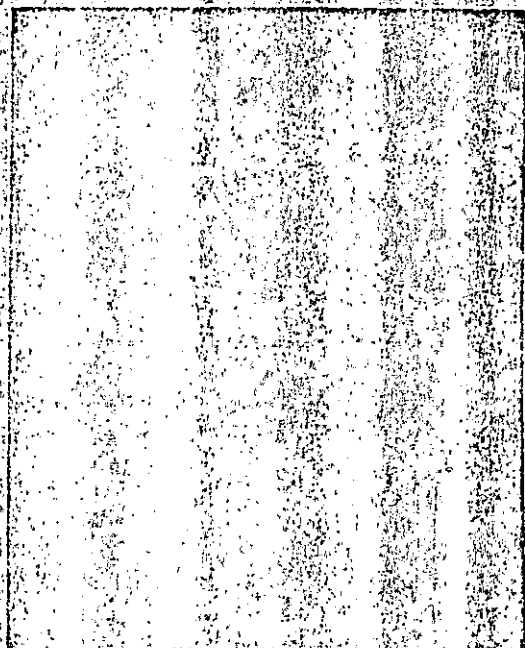
ELV vs STS COST COMPARISON

- CURRENT ASSESSMENT
 - CURRENT PRICE (\$18M (75\$)) IS COMPETITIVE WITH ELV'S. SHARED SHUTTLE PRICE EQUALS APPROXIMATELY:
 - 80% DELTA PRICE
 - 60% ATLAS/CENTAUR PRICE IF P/L SHUTTLE OPTIMIZED
 - 65% ATLAS/CENTAUR IF P/L DUAL COMPATIBLE
 - 85% TITAN 34 D PRICE IF FOUR TITAN LAUNCHES PER YEAR
 - 80% TITAN 34 D PRICE IF TWO TITAN LAUNCHES PER YEAR
- FUTURE PLANS
 - PRICE FOR LAUNCH IN FY 1980 EXPECTED IN \$31 - \$35M (75\$) RANGE IF PRICE IS \$32M (75\$) SHARED SHUTTLE PRICE EQUALS APPROXIMATELY:
 - 70% DELTA PRICE
 - 60% ATLAS/CENTAUR PRICE IF P/L SHUTTLE OPTIMIZED
 - 100% ATLAS/CENTAUR PRICE IF P/L DUAL COMPATIBLE
 - 80% TITAN 34 D PRICE IF FOUR TITAN LAUNCHES PER YEAR
 - 85% TITAN 34 D PRICE IF TWO TITAN LAUNCHES PER YEAR

CHART 11 - Provides a description of Geostationary Platform

EXPERIMENTAL GEOSTATIONARY PLATFORM	
DESCRIPTION/FUNCTION:	To demonstrate technologies needed for operational geostationary platforms in the 1980's, and to permit tests of new communications technologies. Such platform will be required for utilization of orbit slots, spectrum resource, and for science experiments, remote Earth observations, innovative information services, and national security.
NASA CENTER:	MSFC
CONTRACTOR:	General Dynamics
FUNDING:	1980 - 200K plus 100K from OSTP 1981 - 200K 1982 - 300K
STATUS:	Final step under study
PROPOSED NEW START:	1980
PROPOSED FIP (FISCAL YEAR):	1980
RELATION TO OTHER PROGRAMS:	Supported by large space structure systems studies.

CHART 12 - Geostationary Platform



CHARTS 14 & 15 - A description of NASA's Small Self-Contained Payloads Program used on the Shuttle

SMALL SELF-CONTAINED PAYLOADS
(GETAWAY SPECIALS)

DEFINITION PAYLOADS THAT REQUIRE MINOR LIFE SUPPORTS PROVIDED ON SPACE VEHICLES TRANSITING THROUGH LOW-ORBIT CIRCLES

QUALIFICATION SCIENTIFIC RESEARCH AND DEVELOPMENT

PRICE BETWEEN \$3,000 AND \$10,000 DEPENDING ON SIZE AND WEIGHT

CATEGORIES INDUSTRIAL - PHARMACEUTICAL RESEARCH, MATERIALS TESTING AND PACKAGING
EDUCATIONAL - PURE AND APPLIED RESEARCH
INDIVIDUAL - PRIVATE CITIZENS TESTING INNOVATIONS AND RESEARCH IDEAS
GOVERNMENTAL - SCIENTIFIC EXPERIMENTS BY ALL AGENCIES OF FEDERAL, STATE AND OTHER GOVERNMENTS

RESERVATION SUBMIT \$500 EARNEST MONEY PAYMENT TO:
DIRECTOR, FINANCIAL MANAGEMENT
CODE BF-6
NASA HEADQUARTERS
WASHINGTON, DC 20546

INFORMATION CONTACT: MS. DONNA MULLER AT NASA HEADQUARTERS
(202) 755-2427

CHART 13 - A summary of the NASA commercial effort involving Materials Processing in Space

MATERIALS PROCESSING IN SPACE (MPS)
COMMERCIAL MPS PARTICIPANTS

- **JOINT ENDEAVOR AGREEMENT**
 - PROVIDES FREE FLIGHT TIME ON STS - NO EXCHANGE OF FUNDS BY NASA - INDUSTRY PROVIDES A FREE COMMERCIAL PRODUCT IN LOW G ENVIRONMENT OF SPACE
 - MCDONNELL DOUGLAS (SIGNED JANUARY 25, 1980)
 - FIRST CONTRACTS WITH TELECOMMUNICATIONS APPARATUS TO DEVELOP COMMERCIAL USEFUL PRODUCTS
 - GTE CORPORATION (SIGNED JANUARY 20, 1982)
 - GTE HAS CONTRACTS WITH NASA TO UNIVERSITY AND INDUSTRIAL RESEARCHERS AND MICROGRAVITY RESEARCH ASSOCIATES, INC. (PROPOSED)
 - ASSESSING GROWING MARKET CRISTALS, FIBER OPTICS, AND COMPUTER INTEGRATED CIRCUITS
- **TECHNICAL EXCHANGE AGREEMENT**
 - PROVIDES FOR SHORT DURATION LOW G FLIGHT ON DROP TUBES/DROP TOWER AND KC-135 - NO EXCHANGE OF FUNDS
 - GEORGE W. H. COMPANY (SIGNED JUNE 25, 1981)
 - PROVIDES EXPERIMENTAL RESEARCH CASTING PROCESS
 - DUPONT (SIGNED JANUARY 27, 1982)
 - INVESTIGATING MATERIALS PROPERTIES OF VARIOUS ALLOYS
 - NCO RESEARCH AND DEVELOPMENT CENTER, INC. (SIGNED JANUARY 20, 1982)
 - INVESTIGATING POLYMER PROCESS AT 100°C
- **INDUSTRIAL GUEST INVESTIGATOR**
 - NASA PROVIDES INVESTIGATOR AND COMPANY PRINCIPAL INVESTIGATOR
 - COLLABORATE ON RESEARCH AREA OF MUTUAL INTERESTS - NO EXCHANGE OF FUNDS
 - TRW, CLEVELAND (SIGNED APRIL, 1980)
 - INVESTIGATING POLYMER PROCESSING AT 100°C

OFFICE OF SPACE TRANSPORTATION OPERATIONS	
SMALL SELF-CONTAINED PAYLOADS	
RESERVATIONS	TOTAL = 322
INDUSTRIAL	158
EDUCATIONAL	85
INDIVIDUAL	51
U.S. GOVERNMENT	28
MILESTONES	
• FIRST USA SORLING	STS-3 6/81
• PROOF FLIGHT CANNISTERS	STS-3 3/82
• FIRST GAS PAYLOAD	STS-4 7/82
• UP TO 5 GAS PAYLOADS	STS-5 11/82

THE ARIANE CHALLENGE

- **ARIANESPACE MARKETING SERVICES AGGRESSIVELY**
 - GOODMAN AIRSPACE, TOLLON AND JETEC MARKETING REPRESENTATIVE
 - BELL HAS MADE AGREEMENT TO BUILD AND MARKET IN ATLANTA FOR ARIANESPACE MARKETING SERVICES FOR ARIANESPACE
 - BELL HAS MADE AGREEMENT TO BUILD AND MARKET IN ATLANTA FOR ARIANESPACE MARKETING SERVICES FOR ARIANESPACE
 - 25% OF AN AT 15 MONTHS FROM THE START
 - FULL PAYMENT SCHEDULE STARTS 12 MONTHS AFTER LAUNCH AT 15 MONTHS
- **USERS THAT OPTED FOR ARIANE LAUNCH SERVICES RATHER THAN NASA'S**

USER	NUMBER OF PAYLOADS
● INTELSAT	2
● NORBIENI PACIFIC	1 (2 IS POSSIBLE)
- **USERS DOUBLE BOOKED WITH ARIANE AND NASA**

USER	NUMBER OF PAYLOADS
● AEROSAT	2
● COLUMBIA	2
● WETTERLING	1
● RCA AMSTEAM	1
● ANDRISA	2
● BELL TELE OPERATING	1
● BELL TELE OPERATING COMP	1
● TRAVEL	2

ARIANE
EUROPE'S EXPENDABLE LAUNCHER.

DR. KLAUS ISERLAND
Deputy Director General

ARIANESPACE

ABSTRACT

ARIANE as a competitive expendable launcher has received recently growing world-wide attention and raised much interest in the United States. This paper is aimed at exposing ARIANE's features and present status, its commercialization and finally its order book and future prospects.

INTRODUCTION

With the ARIANE 1 to ARIANE 4 family of expendable launchers, Europe is now offering up to far in the 90's a space transportation system which, although expendable, has received bookings from different parts of the world up to 1986 so far; and which appears to remain competitive at least during this decade. This success of an expendable launcher in our days is certainly due to its low-risk concept, its performances matching well the market needs, its long-term availability and the industrial approach chosen for its marketing and sales.

TEXT

Europe has engaged in a long term effort to assure the availability of a ballistic space transportation system by developing the ARIANE family (fig.1). The development of ARIANE 1 with 1 780 kg in GTO is now achieved, modifications are presently introduced and solid strap-on boosters developed to obtain in 1983 performances of 2 175 kg GTO for ARIANE 2 and 2 580 kg for ARIANE 3.

Also, just at the beginning of 1982 the European nations decided to go ahead with the ARIANE 4 program in order to have available in 1986 a vehicle capable to boost up to 4 200 kg in GTO.

The concept

The concept of ARIANE was deliberately aimed at using well proven technologies, in particular in the two first stages (both stages use the same "VIKING" engine which is the latest of an engine family developed for the 2nd stage of the EUROPA-2 launcher and the successful French "DIAMANT" series), while still achieving high performance through cryogenic propulsion in the 3rd stage (with a prudent approach by choosing low chamber pressure) and high injection accuracy through a very precise inertial guidance. This may explain why already the first test flight was completely successful, an achievement which, to our knowledge, has only one precedent: the US SATURN family of launchers.

In the same philosophy, the continuous increase in performance from ARIANE 1 to ARIANE 4 is achieved by introducing successively conservative improvements with now major technological steps.

Thus ARIANE 2 differs from ARIANE 1 only by a thrust chamber increase of less than 10 % and propellant increase in the 3rd stage by 25 %. ARIANE 3 is identical to ARIANE 2; merely 2 solid strap-on boosters are added. The decision to fly in ARIANE 2 or ARIANE 3 configuration can be taken as late as 3 to 6 months before launch. ARIANE 4 uses the same 2nd and 3rd stage as ARIANE 3, the first stage is stretched to take some 50 % more propellants, while using the same engines as ARIANE 3. Different combinations of solid and liquid strap-on boosters can be used to match the actual payload, the solid ones being those used for ARIANE 3, the liquid ones using the same "VIKING" engines as the 1st and 2nd stage.

Of course, the payload compartment - i.e. the fairings - is augmented in proportion to the increasing performance.

Meeting the market

To offer space transportation responds today to a market need. Fig. 2 shows geosynchronous orbit traffic of the GEO 4th age including contracted or reserved launchings until 1986. The traffic growth is striking. However, the market does not appear to us unbalanced as sufficient transportation capacity seems to be available through the existence of the US ballistic launchers, the STS and the European ARIANE.

Europe has realized the importance of this market and has therefore tried to find the best suited response to growing industrial and commercial activities by creating the first space transportation company in the world, ARIANESPACE, in March 1980. This company with a capital of 120 million FF has been created by 36 European aerospace companies, 13 European banks and the French National Space Agency C.N.E.S. It has been entrusted with the worldwide marketing of the ARIANE launch services and assures with its own resources continuous production of the vehicle and execution of launchings and launch related operations.

The role of ARIANESPACE

This company houses the managerial, marketing and engineering skills to operate the ARIANE launch vehicle. All follow-on development of ARIANE is however conducted under the responsibility of ESA and executed by the French National Space Agency. Upon completion, ARIANESPACE undertakes to open-rate all demonstrated systems.

ARIANESPACE is based in Evry, in the Southern suburbs of Paris, in France.

All of the 36 industrial shareholders of ARIANESPACE are its suppliers. The French National Space Agency holds 34%. Main suppliers are presently:

AEROSPATIALE	* 1st, 3rd stage, system integration
ERNO	* 2nd stage
MATRA	* vehicle equipment bay
SEP	* engines of 1st, 2nd and 3rd stage
CONTRAVES	* fairings
DIFEZA E SPAZIO	* solid boosters.

They hold 30% of the shares, the remainder being held by the subcontractors and the banks.

France in particular followed by Germany have most of the interest in this venture.

It is our impression that the commercial initiative to create ARIANESPACE has been well received.

The order book grew from 1.4 billion FF in 1980 to 3 billion at the end of 1981. A total of 19 vehicles, including the 4 flight test vehicles, and 6 launchers of the first operational series have been produced or are presently under production, 9 of which ordered by ARIANESPACE, and longlead items for 5 more are ordered. As entrepreneurship in the market spreads, commercial entities generally respond more flexibly and adjust better to market needs. We also believe that the commercial community benefits from the fact that the monopolistic market situation of space transport has been replaced by a competitive one.

The launch service offered

ARIANESPACE offers to its clients dedicated and shared launchings. In a dedicated launch, generally one spacecraft uses the entire performance of the ARIANE. The best example here are the launchings of the INTELSAT V and VA.

In a shared launch two spacecraft of the Thor-Delta-PAM-D or STS-SSUSD class are put on one launch vehicle using a special double launch adaptor called SYLDA (Système de Lancement Double Ariane). This double launch mode in particular makes the ARIANE launch extremely cost-effective for a PAM-D type spacecraft. Fig. 3 shows launch configurations for shared launchings.

The ARIANE 4 shall offer larger payload capability and volume to spacecraft. Fig. 4 depicts the volume available for shared launchings as compared to the presently available volume size of ARIANE 3, DELTA or STS-SSUSD. ARIANE 4 shall not only allow shared launchings of PAM-D type spacecraft, but also shared launchings of spacecraft of 2000 kg or more together with PAM-D type spacecraft.

ARIANE launchings take place in French Guiana, which is an overseas department of France. The launch base has a privileged location about 5 degrees north of Equator. Since its establishment in 1968, it has become one of the most modern launch sites in the world and offers all buildings and equipment necessary to safely and expeditiously prepare spacecraft for launch. Here again, Europe has engaged into a long term effort as a second launch pad is presently under construction and work to extend the available spacecraft preparation and check-out buildings has started. The second pad shall be in service in 1985 and by that allow to increase launching frequency to 8 and later to 10 per year.

ARIANESPACE launch services can be obtained by first reserving a launch slot against payment of US \$ 100 000 per reservation. A contract for launch services should typically be signed 3 years before launch. It is also possible to buy a paying option for a duration of 12 months valid until 2 years before launch.

It is our understanding that insurances against launch failure are available on the market at rates comparable to rates for other expendable launch vehicles. Against third party liability, ARIANESPACE takes out unlimited insurance for its clients for three years.

Commercial use of ARIANE is best reflected in the present status of orders and reservations of this vehicle that shows continuous and increasing use of the system. Flight qualification of this vehicle has been achieved by 4 test flights called L01 through L04.

A special feature of this period of test flights that extended over 2 years was that not only test and measurement equipment has been flown, but also real spacecraft and this from the second test flight onwards.

Therefore, we have not only acquired knowledge of the launch vehicle itself but also qualified all service related buildings and operations and have also launched two spacecraft at once on L03 followed by a commercial spacecraft (MARECS-A) on L04.

Now the initial phase of operational exploitation of the ARIANE launch vehicle has started with the flight L5 in May 1982.

The order book

Review of the order and reservation list (fig. 5) allows the following conclusions:

1) The launch sequence will be gradually increased from 4 in 1982 to 5 in 1983 and 1984. It is presently planned a number of up to 8 launchings in 1985. This will be made possible through the 2nd launch pad.

2) 1982 and 1983 are fully booked. However, two flight opportunities on L11 and L12 could be made available. Towards the end of 1984, a fifth launching is entirely available.

3) All types of commercial spacecraft presently built in either Europe or US will be flown at least once on ARIANE.

4) The maiden flight of ARIANE 4 is scheduled for late 1985.

5) Export is vital for ARIANE, the portion of export missions to European missions approaches 30%. We assume that this relation will be maintained.

COSMOS 1988

The success of ARIANE has created a certain market situation beneficial to the company. As competition has been reduced, as the most important driver towards success in more business, we are sure that we have managed into a period of growth. Therefore,

Europe expects extensive use of this transportation system through a long period of operation, and understands it to be competitive with other available expendable systems or with the Space Shuttle.

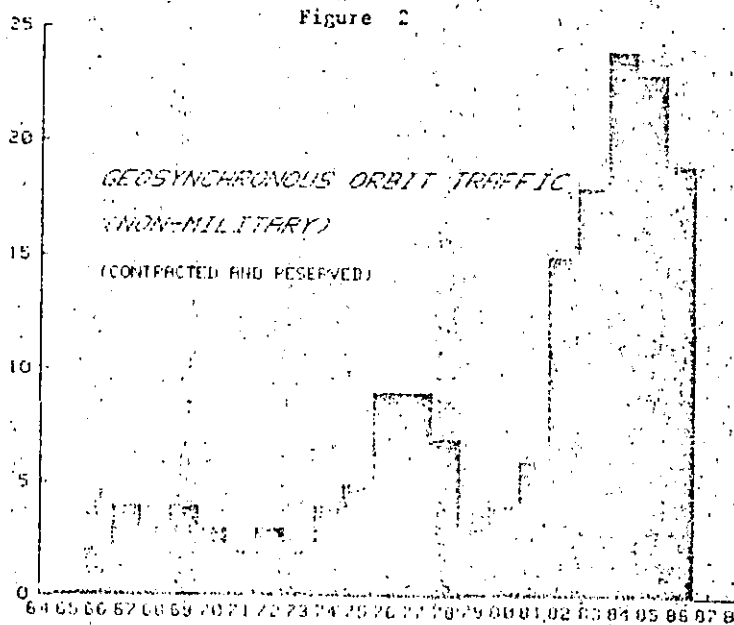
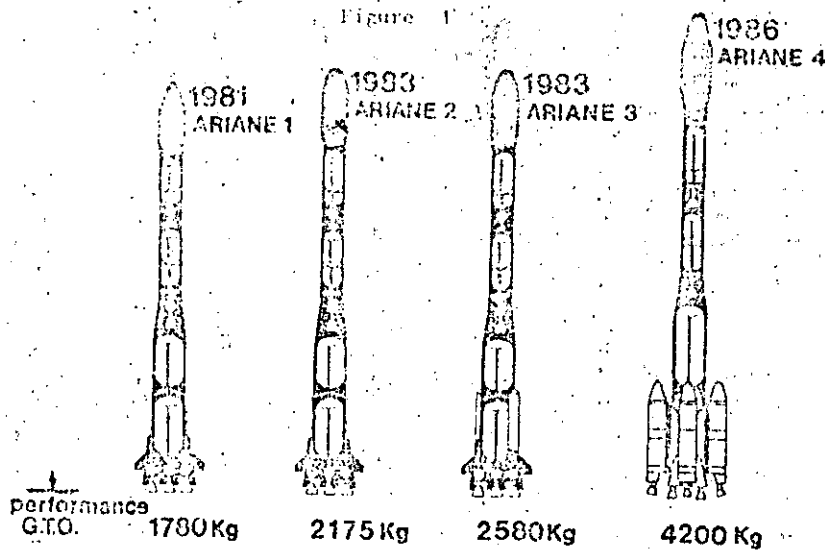


Figure 3

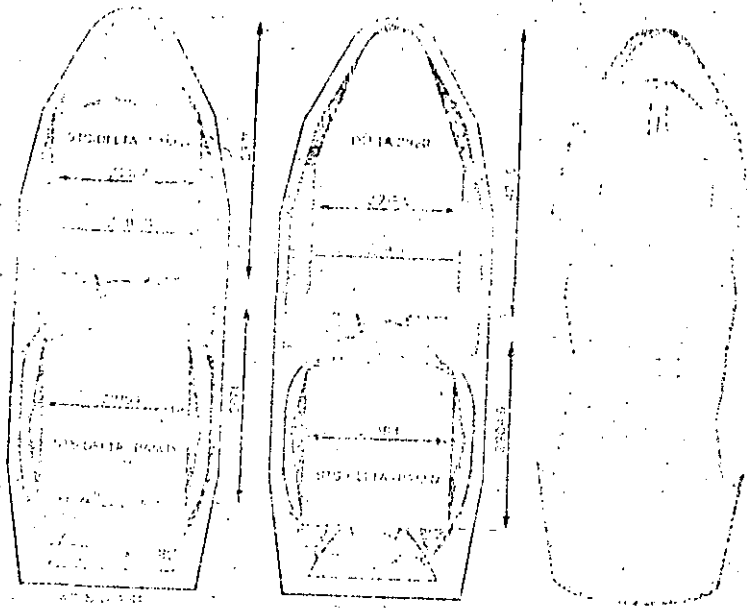


Figure 4

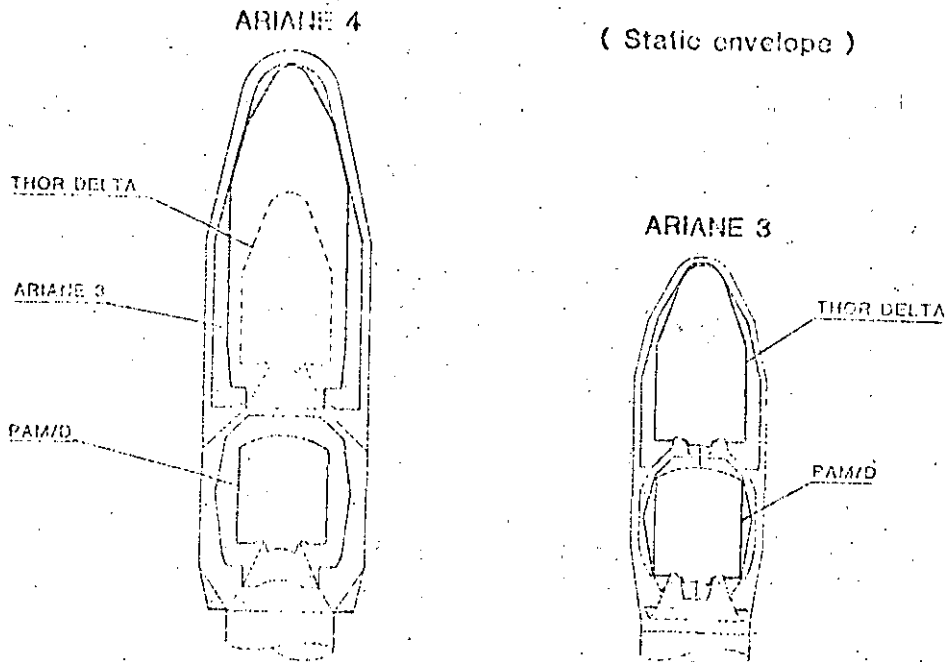


Figure 5

DGA/TC-KI/HC
4/02/82

STATUS OF ORDERS AND
RESERVATIONS OF THE
ARIANE LAUNCHER

1980 - 1985

L01	AR.1	CAT	12/79
L02	AR.1	CAT + AMSAT + FIREWHEEL	05/80
L03 L04	AR.1 AR.1	CAT + METEOSAT + APPLE CAT + MARECS-A	06/81 12/81
L 5 L 6 L 7 L 8	AR.1 AR.1 AR.1 AR.1	MARECS-B + SIRIO-2 ECS-1 + AMSAT INTELSAT V F6 EXOSAT	04/82 07/82 10/82 12/82
L 9 L10 L11 L12 L13	AR.1 AR.1 AR.1 AR.2 AR.3	INTELSAT V F7 INTELSAT V F8 or ECS-2 ECS-2 or INTELSAT V F8 TELECOM-1A TELECOM-1B + WESTAR-VI	02/83 05/83 07/83 09/83 12/83
L14 L15 L16 L17 L18	AR.3 AR.3 AR.2 AR.3 AR.3	SPACENET-1 + ARABSAT-1 GSTAR-1 + (ECS-3) SPOT-1 + VIKING GSTAR-2 + SPACENET-2 (SATCOL-1) + ...	02/84 04/84 06/84 08/84 12/84
		INTELSAT VA F14 TV-SAT TDF 1 (AUSSAT 1) (SATCOL 2) GIOTTO INTELSAT VA F15 ARIANE 4/01 (STC) (AUSSAT 2)	1st half year 1985 2nd half year 1985
		Note : Second launch post available from 1985 onwards	
		SPOT 2 L-SAT (CLT) (TELE-X) (INTELSAT VI) (TEL-SAT)	Year 1986

() = reservation

JAPAN'S EXPENDABLE LAUNCH VEHICLES

Takashi Matsuda, Masafumi Miyazawa
and Shinji Nio

National Space Development Agency of Japan

INTRODUCTION

The National Space Development Agency of Japan (NASDA) has been conducting the development and operation of a satellite launcher called N-rocket over the past ten years. This N-series rocket, Japan's first liquid propellant booster, is a three stage vehicle capable of launching medium size applications satellites. The N launch vehicle program, from the basic N, called N-I vehicle, through the current N, called N-II vehicle, has been supported by the United States through government level agreements. Hardware and technology of the NASA Thor-Delta have been transferred and applied to both N-I and N-II vehicles.

The N-I rocket project started in 1970 and this launch vehicle became operational in 1975 when it successfully put an 85 kg Engineering Test Satellite into a planned orbit accurately in its first flight. Since then the N-I rocket has launched six satellites in total, with five successful flights and one malfunction connected with the mission failure.

Following the successful operation of the first generation of the N (N-I launch vehicle), the upgraded N-II vehicle has entered on the operational phase with two successful flights in 1981. Being capable of placing about 350 kg payload into geostationary orbit, this N-II rocket is the heaviest launcher at the present time in Japan to be used for launching various applications satellites over the coming several years. Figure 1 shows the lift-off scene of the first N-II launch which took place in February 1981.

To meet the need for launching large capacity applications satellites in near future as requested by Japan's satellite users, NASDA has been carrying out study and development work of a future rocket, called H-I launch vehicle with high performance capability. This new launch vehicle, with the estimated capability of placing about 550 kg payload into geostationary orbit, is expected to meet the need for heavier applications satellites requested from Japan's future users in the late 1980s through the 1990s.

This paper presents a brief description of N and H vehicles including configuration, subsystems and performance capability. The current launch schedule and mission summary are also presented.

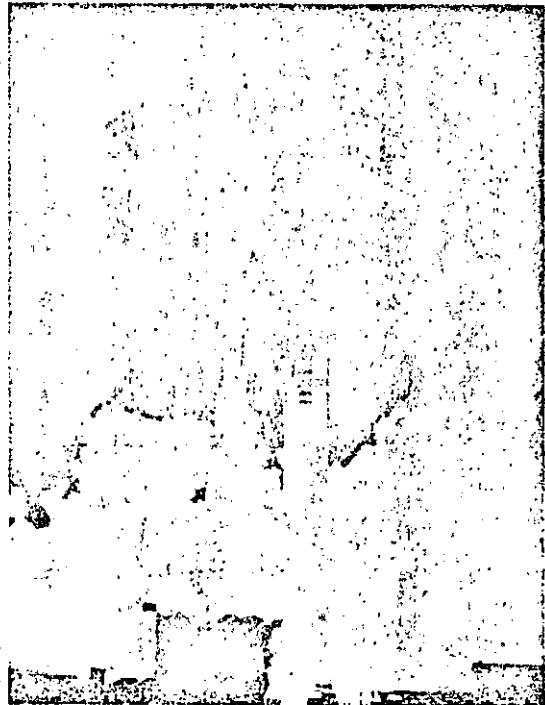


Fig. 1 Lift-off of N-II Launch Vehicle (Feb. 1981)

LAUNCH SCHEDULE AND MISSIONS

The NASDA launch vehicles from N-I through H-I have supported and will support various missions for space applications of Japan. The past and future launch schedule (1975 through 1988) is shown in Table 1. The status for launched missions and the scheduled missions are briefly described in Table 2.

The N-I rocket will be phased out with the expected launch of ETS-III in this August. Following the successful launch of the Geostationary Meteorological Satellite-2 in 1981, the current N-II vehicle is scheduled to support important missions for domestic communications, broadcasting and earth observations over the next several years.

If the H-I development program progresses as currently scheduled, the first test flight will be conducted in 1986 with the two-stage configuration, followed by the three-stage operational flight in the late 1980s through 1990s.

Table 1 NASDA LAUNCH VEHICLES MASTER SCHEDULE

CY	'75	'76	'77	'78	'79	'80	'81	'82	'83	'84	'85	'86	'87	'88	
VEHICLE	'75	'76	'77	'78	'79	'80	'81	'82	'83	'84	'85	'86	'87	'88	
N-I	ETS-I ↑ ISS ↑	ETS-II ↑	ISS-b ↑	ECS ↑	ECS-b ↑			ETS-III ↑							
N-II						ETS-IV ↑	GMS-2 ↑	CS-2a ↑	CS-2b ↑	BS-2a ↑	GMS-3 ↑	BS-2b ↑	MOS-1 ↑		
H-I											GS-1 ↑ (2 stage)		ETS-V ↑ (2 stage)	CS-3a ↑	CS-3b ↑

LAUNCHED / FIRM PLAN
 UNDER STUDY
 BACKUP FLIGHT

Table 2 NASDA PROGRAMS MISSION SUMMARY

LAUNCHED

FLIGHT NUMBER	SATELLITE NAME	LAUNCH DATE	WEIGHT (Kg)	ORBIT PARAMETERS (Km/Km/deg.)	LAUNCH VEHICLE	MISSION
1	ETS-I	9/9/75	83	1100/980/47	N-I	ENGINEERING TEST SATELLITE
2	ISS	2/29/76	139	1010/990/70	N-I	IONOSPHERE SOUNDING SATELLITE
3	ETS-II	2/23/77	130	GEOSTATIONARY	N-I	ENGINEERING TEST SATELLITE
4	ISS-b	2/16/78	141	1220/980/70	N-I	IONOSPHERE SOUNDING SATELLITE
5	ECS	2/6/79	130	-	N-I	EXPERIMENTAL COMMUNICATIONS SATELLITE MISSION FAILURE DUE TO SPACECRAFT/VEHICLE COLLISION
6	ECS-b	2/22/80	130	-	N-I	EXPERIMENTAL COMMUNICATIONS SATELLITE MISSION FAILURE DUE TO SPACECRAFT APOGEE MOTOR MALFUNCTION
7	ETS-IV	2/11/81	640	35800/225/28.5	N-II	ENGINEERING TEST SATELLITE
8	GMS-2	8/11/81	340	GEOSTATIONARY	N-II	METEOROLOGICAL SATELLITE

SCHEDULED

FLIGHT NUMBER	SATELLITE NAME	LAUNCH YEAR	APPROX. WEIGHT (Kg)	ORBIT PARAMETERS (Km/Km/deg.)	LAUNCH VEHICLE	MISSION
9	ETS-III	1982	385	1000/1000/45	N-I	ENGINEERING TEST SATELLITE
10	CS-2a	1983	350	GEOSTATIONARY	N-II	DOMESTIC COMMUNICATIONS SATELLITE
11	CS-2b	1983	350	GEOSTATIONARY	N-II	DOMESTIC COMMUNICATIONS SATELLITE
12	BS-2a	1984	355	GEOSTATIONARY	N-II	DOMESTIC BROADCASTING SATELLITE
13	GMS-3	1984	350	GEOSTATIONARY	N-II	METEOROLOGICAL SATELLITE
14	BS-2b	1985	355	GEOSTATIONARY	N-II	DOMESTIC BROADCASTING SATELLITE
15	GS-1	1986	1200	1500/1500/50	H-I	GEODETIC SATELLITE AND TEST PAYLOAD (TEST FLIGHT)
16	MOS-1	1986	750	5100/1039 SUBSYNCHRONOUS	N-II	MARINE OBSERVATION SATELLITE
17	ETS-V	1987	550	GEOSTATIONARY	H-I	ENGINEERING TEST SATELLITE
18	CS-3a	1988	550	GEOSTATIONARY	H-I	DOMESTIC COMMUNICATIONS SATELLITE
19	CS-3b	1988	550	GEOSTATIONARY	H-I	DOMESTIC COMMUNICATIONS SATELLITE

VEHICLE SYSTEM DESCRIPTION

The outboard profile of N-I, N-II and H-I rockets is illustrated in Fig. 2. An overall description of the vehicles subsystems is presented in Table 3.

The N-I rocket is a three-stage, radio-guided vehicle with overall length of 32.6 m, maximum diameter of 2.4 m and a lift-off weight of 90 tons. The first stage consists of a MB-3 engine, liquid propellant tank and three Castor-II solid strap-on boosters. The second stage propulsion system uses a regeneratively cooled LF-3 engine and a liquid propellant tank, which were developed in Japan. An off-loaded TE-364-3 solid motor of the Delta vehicle is used as the third stage.

The N-II vehicle, an upgraded version of the N-I vehicle, is 35.4 m long and 2.4 m in diameter with a lift-off weight of 135 tons. The first stage uses an Extended Long Tank with the same MB-3 engine and nine Castor-II strap-on boosters. These major first stage components are Thor-Delta hardware but license-produced in Japan.

The second stage propulsion system (SSPS), AJ10-118FJ, has been improved from the original model for the Delta 1900 series by a U.S. company; the tank volume and nozzle expansion ratio were increased. To accommodate increased payloads requested by users, this basic SSPS is being further improved: increase in the combustion chamber pressure (Pc-up)

and employment of the improved injector (ITIP). The engine is of pressure-fed, ablative-cooled type and has a restart capability.

A larger solid motor, TE-364-4, is a Delta component applied to the N-II third stage. Also, the Delta Inertial Guidance System (DIGS) is employed for guidance and control of the vehicle.

The H-I rocket is a three-stage, inertial-guided vehicle with overall length of 40 m, maximum diameter of 2.4 m and a lift-off weight of 140 tons. The first stage and strap-on boosters of the H-I vehicle are the same as those of the N-II vehicle. Much efforts are being concentrated on the development of new upper stages with high performance.

The second stage propulsion system uses liquid oxygen and liquid hydrogen as propellants, with an average vacuum thrust of 10 tons and a vacuum specific impulse of 442 sec. A new large solid motor with the propellant weight of 1.9 tons is being developed to be used for the third stage. An inertial guidance system of stable platform type will be used for guidance and control of the vehicle.

Various development tests of these major components have been carried out by domestic efforts with a substantial progress.

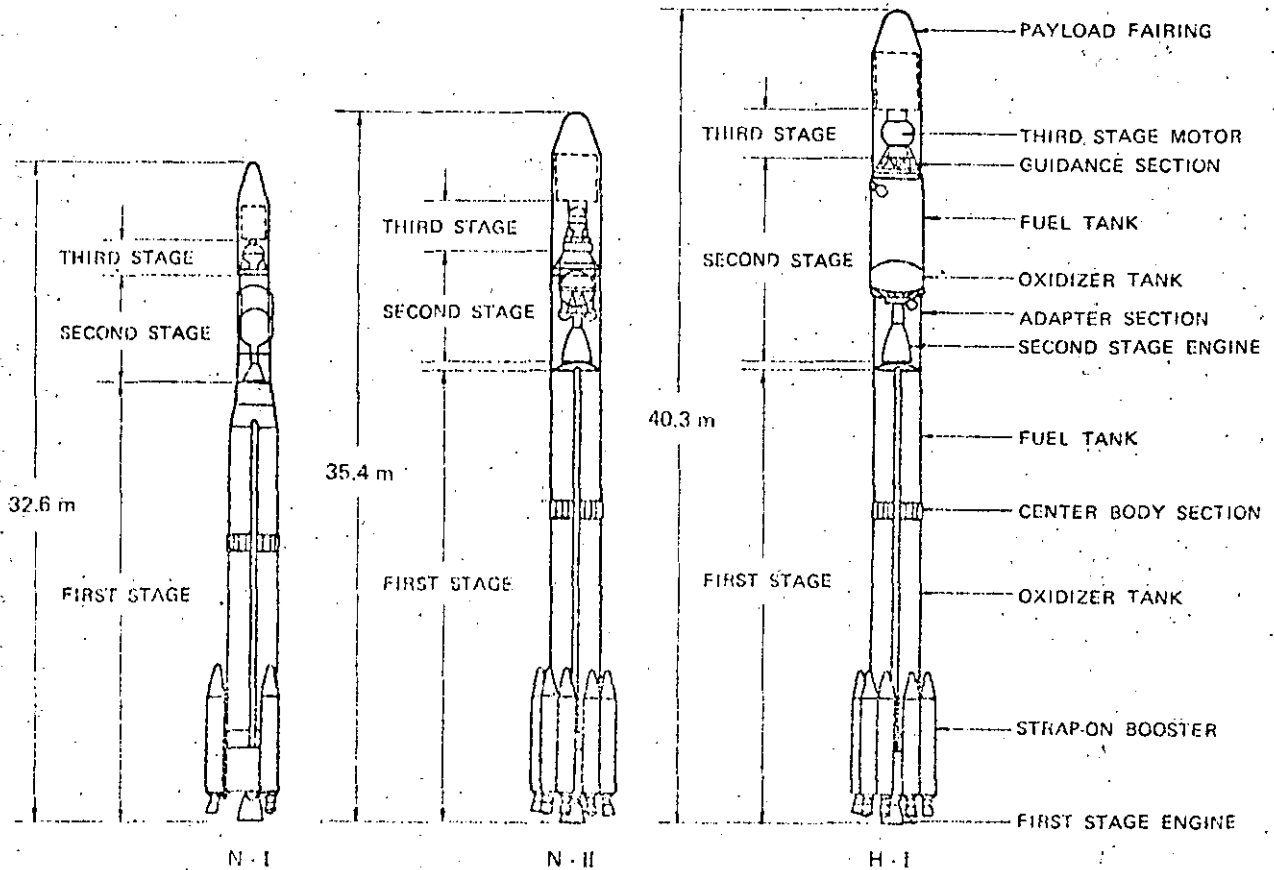


Fig. 2 OUTBOARD PROFILE COMPARISONS

Table 3 MAIN CHARACTERISTICS OF N-I, N-II AND H-I VEHICLES

		VEHICLE		
		N-I	N-II	H-I
SIZE	OVERALL LENGTH (m)	32.6	35.4	40.3
	DIAMETER (m)	2.4	2.4	2.4
	LIFT-OFF WEIGHT (APPROX. TON)	90	135	140
FIRST STAGE	ENGINE	MB-3	MB-3	MB-3
	PROPELLANT	LOX/RJ-1	LOX/RJ-1	LOX/RJ-1
	AVERAGE THRUST (TON, SEA LEVEL)	78	78	78
	SPECIFIC IMPULSE (SEC, SEA LEVEL)	249	249	249
	TOTAL/PROPELLANT WEIGHT (TON)	70/60	86/81	88/81
STRAP ON BOOSTER	MOTOR	CASTOR II	CASTOR II	CASTOR II
	PROPELLANT	SOLID	SOLID	SOLID
	AVERAGE THRUST (TON, SEA LEVEL)	23.7 x 3	23.7 x 9	23.7 x 9
	SPECIFIC IMPULSE (SEC, SEA LEVEL)	238	238	238
	TOTAL/PROPELLANT WEIGHT (TON)	4.5/3.8 x 3	4.5/3.8 x 9	4.5/3.8 x 9
SECOND STAGE	ENGINE	LE-3	AJ10-118FJ	LE-5
	PROPELLANT	N ₂ O ₄ /A-50	N ₂ O ₄ /A-50	LOX/LH ₂
	AVERAGE THRUST (TON, VACUUM)	5.4	4.4	10.5
	SPECIFIC IMPULSE (SEC, VACUUM)	285	315 - 319 (ITIP)	442
	TOTAL/PROPELLANT WEIGHT (TON)	5.8/4.7	6.8/5.8	10.6/8.6
THIRD STAGE	MOTOR	TE-364-14	TE-364-4	-
	PROPELLANT	SOLID	SOLID	SOLID
	AVERAGE THRUST (TON, VACUUM)	4.0	6.8	9.0
	SPECIFIC IMPULSE (SEC, VACUUM)	290	286	288
	PROPELLANT WEIGHT (TON)	0.56	1.05	1.9
FAIRING	DIAMETER (m)	1.7	2.4	2.4
	MAX. SPACECRAFT DIAMETER (m)	1.4	2.2	2.2
GUIDANCE SYSTEM		RADIO GUIDANCE	DELTA INERTIAL GUIDANCE SYSTEM	INERTIAL GUIDANCE SYSTEM

PERFORMANCE GROWTH

Figure 3 shows a schematic presentation of NASDA vehicles performance growth in terms of geosynchronous payload. The performance capability of the current N(N-II) vehicle was greatly increased as a result of improvements described above over the basic N(N-I) vehicle.

It is noted here that the current N-II launch vehicle has a similar configuration as the Delta 1910 series, while its capability is rather close to the 2910 series. The same ITIP SSPS hardware will be used for the new Delta 3920 series.

Much higher performance growth is expected of the H-I vehicle due to the use of a cryogenic propulsion system and an optimum (larger) third stage motor.

A feasibility study is being carried out to further upgrade the payload capability of the presently defined H-I launch vehicle.

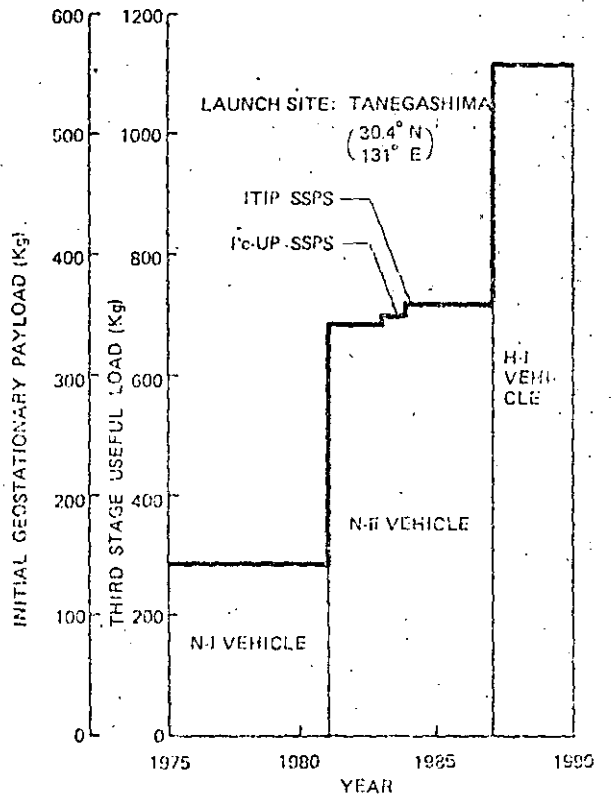


Fig. 3 GEOSYNCHRONOUS PERFORMANCE GROWTH

SPACECRAFT TECHNOLOGY FOR DIRECT BROADCAST MISSIONS

Herbert D. Cohen

TRW Space and Technology Group

ABSTRACT

This paper surveys the technologies required for presently conceived direct broadcast satellite (DBS) projects. The technologies include launch vehicles, shaped beam antennas, high power traveling wave tubes (TWT^s), electronic power conditioners for TWT^s, lightweight, high power solar arrays, heat pipe radiators and output multiplexers. It is concluded that the technology is available and only detailed engineering development and test is required for DBS construction.

INTRODUCTION

The term direct broadcast has been applied to a variety of satellite programs covering the frequencies from 850 MHz to 20 GHz and beyond. For the purposes of this paper, we shall restrict our discussion to the 12 GHz band and to TV broadcast direct to the home (DBS). DBS is yet in its infancy but has evoked a tremendous response for potential commercial exploitation both for conventional and high definition (HDTV) applications. Nonetheless, past, present and future programs span a wide range of spacecraft size and use different levels of key technologies. A technologically representative set of programs and studies listed in Table 1 includes Delta class, and greater than Atlas-Centaur class satellites. A small domestic communications satellite (Anik B) using a 20 watt traveling wave tube (TWT) and less than 1 kilowatt output solar array is presently performing a pre-operational mission in Canada, while a Nordic satellite study utilizes a 450 watt TWT requirement and a 9 kilowatt solar array. Satellite designs are often required to meet dual launch requirements of expendables (Ariane) and Shuttle and may require special ascent stages intermediate to PAM A and IUS.

TABLE 1. TECHNOLOGICALLY REPRESENTATIVE DBS SYSTEMS

PROGRAM	STATUS	ANTENNA	# CHANNELS	TWT OUTPUT (WATTS)	SOLAR ARRAY (OUTPUT @ 12.1 GHz)	LAUNCH VEHICLE (ON ORBIT MASS (LBS))	THERMAL DESIGN
ANIK B	OPERATIONAL	SHAPED BEAM OFFSET PARABOLA SIMPLE FEED	NO	20	~1000	DELTA 214 1000	NO HEAT PIPES
ANIK M2	FLYING DEVELOPMENT	SHAPED BEAM OFFSET PARABOLA SIMPLE FEED	YES	100	~1000	DELTA 214 1000	NO HEAT PIPES
LUXEMBOURG	PLANNED	SHAPED BEAM UNUSUALLY OFFSET PARABOLA SIMPLE FEED	YES	65-70	~1000	STS/PAM 0 OR ARIANE 1 1500	PROBABLY SIMPLE HEAT PIPES
TDI-17V3A1	DEVELOPMENT	SHAPED BEAM OFFSET PARABOLA COMPLEX FEED	YES	230-250	~2000	ARIANE 2 2000	SIMPLE AND VARIABLE CONDUCTANCE HEAT PIPES
STC COMSAT	PLANNED	SHAPED BEAM OFFSET PARABOLA COMPLEX FEED	NO	300	~2000	STS/PAM 0 OR SOLAR ARRIANE 3 1500	PROBABLY SIMPLE HEAT PIPES
LAS	PLANNED	SHAPED BEAM OFFSET PARABOLA COMPLEX FEED	YES	24-250 OR 500	~4000	STS/PAM 0 OR ARIANE 4B 2000	PROBABLY SIMPLE HEAT PIPES
NORDSAT	STUDY	SHAPED BEAM OFFSET PARABOLA COMPLEX FEED	YES	200 AND 500	~1000	STS INTERNATIONAL PROPOSAL OR ARIANE 4DP 2000	SIMPLE AND VARIABLE CONDUCTANCE HEAT PIPES

This paper surveys the technologies required for presently conceived DBS projects. These are summarized in Table 2. These include shaped beam antennas (12/18 GHz) which cover irregular national or regional footprints to maximize EIRP, limit sidelobe levels and provide polarization purity for either linear or circular polarization; TWT^s at power levels up to 450 watts designed for 7-10 year lifetimes, with multiple collectors for high efficiency (approximately 50 percent), with collectors radiating 65-70 percent

TABLE 2. SATELLITE TECHNOLOGY FOR DBS

ITEM	FEATURES	STATUS
LAUNCH VEHICLE (STS AND ARIANE)	• 1500-2000 LBS IN ORBIT	ADVANCED DEVELOPMENT
ASCENT STAGE (PAM D PAM A, SPECIAL)	• EFFICIENT, FLEXIBLE	ADVANCED DEVELOPMENT OR NEW
SOLAR ARRAY (1-30 KW)	• LIGHTWEIGHT (25-30 KG/KW)	ADVANCED DEVELOPMENT OR NEW
ANTENNA (12-18 GHz)	• SHAPED BEAM • OFFSET FEED, OVERSIZED, PARABOLA • MULTIFEED • SIDELobe CONTROL, LOW CROSSPOL • DUAL FREQUENCY	TECHNOLOGY DEVELOPED, NEW APPLICATION
HIGH POWER TWT (100-450W)	• LONG LIFE, DISPENSER CATHODE (7-10 YRS) • MULTIPLE COLLECTOR, HIGH EFFICIENCY (50%) • DIRECT RADIATING COLLECTOR • HIGH COLLECTOR BODY DISSIPATION (85% 25%)	ADVANCED DEVELOPMENT
TWT EPC	• HIGH VOLTAGE (6-15 kV) • HIGH EFFICIENCY (80-90%) • PACKAGING (POTTED VS OPEN)	OPEN PACKAGING SUCCESSFULLY FLOWN, POTTED TECHNOLOGY TO BE DEMONSTRATED
HEAT PIPE RADIATOR	• SIMPLE AND VARIABLE CONDUCTANCE	TECHNOLOGY DEVELOPED, NEW APPLICATION
HIGH POWER MULTIPLEXER	• HIGH Q, LOW LOSS • GOOD HEAT TRANSFER • AVOID MULTIPACTON	TECHNOLOGY DEVELOPED, NEW APPLICATION

of the dissipated energy directly to space and using either helix or coupled cavity slow wave structures; TWT electronic power conditioners (EPC) requiring high voltage (6-15 kv) supplies, with high efficiency (88-90 percent), operating from low voltage or high voltage (100 volts and higher) regulated or unregulated DC power supplies, using potted or open construction; lightweight solar arrays (25-30 kg/kw) providing end-of-life outputs up to 10 kilowatts with limited or no transfer orbit stowed capability; heat pipe radiators simple and variable conductance, coupled and uncoupled, to spread high heat concentrations with different spatial geometries engendered by redundancy modes on common radiators, to survive eclipse with sharply reduced or zero dissipation or to transfer heat from confined geometries with high heat concentrations (output multiplexers); and high power output multiplexers, contiguous combining high Q (for low insertion loss), good heat transfer and avoiding potential multipaction caused by high frequency and high voltage.

Most of the technologies can be seen installed on a four kw class DBS satellite (Figure 1), carrying six channels of 230 watt TWT^s with two for one redundancy. The TWT^s and EPC^s are mounted on the North-South panels (from which the solar arrays protrude) so that the collectors radiate directly to space. Heat pipe radiators are used to spread the heat on the North-South panels and also on the top panel where the output multiplexer is installed.

LAUNCH VEHICLE

Geosynchronous orbit performance for a range of expendable and shuttle based launch vehicles is presented in Table 3. The key boosters for DBS are still in the development stage. This includes the Ariane series and the STS/PAM-D and STS/PAM-A. The Ariane list is incomplete since it skips presently used vehicles and goes directly to the 1985 era and beyond. The Ariane 4 family is just being introduced for 1986 availability and hence only a few typical choices are shown to illustrate the range of payload capability.

Note that performance calculations have been done for the most part using available Thiokol solid apogee motors for comparison. It is recognized that in some cases a liquid will provide somewhat better performance. The beginning of life satellite weight includes various allowances footnoted in Table 3 enabling a comparison between

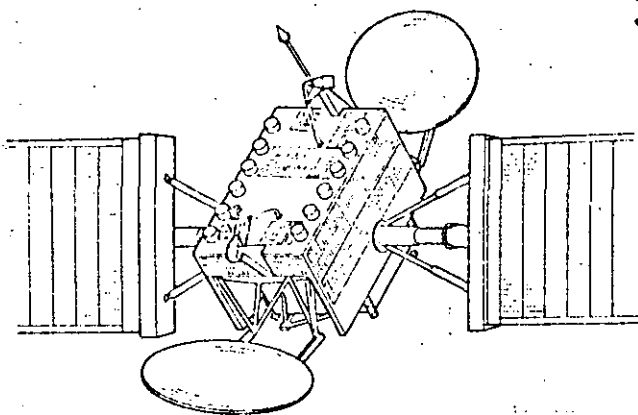


Figure 1. DBS Spacecraft

stages having diverse initial maneuver requirements. Hydrazine is used with a continuous thrust specific impulse of 220 seconds.

STS/PAM-D and STS/PAM-A performance can be "stretched" using an oversized liquid system which provides some of the perigee velocity requirements (ΔV) in addition to the apogee ΔV . The payload gain slope is low providing 100 pounds of additional payload for each 500 pounds of propellant added. The LEASAT integrated propulsion system also uses this technique.

TABLE 3. LAUNCH VEHICLE GEOSYNCHRONOUS ORBIT PERFORMANCE COMPARISON

LAUNCH VEHICLE	WEIGHT IN ¹¹ GEOSYNCHRONOUS TRANSFER ORBIT		RELATIVE COST LIFE ¹² LIFE SATELLITE WEIGHT		MAXIMUM SATELLITE DIAMETER	
	LBS	KG	LBS	KG	FT	M
EXPLODABLE						
DELTA 2900	2,260	1,040	1,360	629	7.7	2.3
ATLAS CENTAUR	5,150	2,335	2,110	1,025	8.5	2.6
ARIAN 3 DUAL LAUNCH	2,515	1,130	1,400	670	10.0	3.0
ARIAN 3E	4,410	2,000	2,110	1,085	12.0	3.6
ARIAN 4E DUAL LAUNCH	4,270	1,915	2,270	1,075	12.0	3.6
ARIAN 5E	9,350	4,200	5,040	2,280	12.0	3.6
SATELLITE						
STS/PAM-D	2,760	1,250	1,780	825	9.10 ¹³	2.77 ¹³
STS/PAM-A	4,400	2,000	2,110	960	14.5	4.4
STS/105			4,670	2,120	14.5	4.4
STS/105 INTEGRATED PROPULSION			10,000	4,540	14.5	4.4
STS/CENTAUR			13,800	6,250	14.5	4.4

11. TRANSFER ORBIT INCLINATION CHOSEN TO MAXIMIZE PAYLOAD AND ADAPT TO AVAILABLE PROPELLE MOTOR
 12. USE EXISTING THICKET SOLID ARGON MOTOR WHEN AVAILABLE INCLUDES ALLOWANCE FOR A/C ADAPTOR SPIN
 DESIGN ACQUISITION AND INITIAL VELOCITY CORRECTION
 13. MOUNTED VERTICALLY IN SHUTTLE BAY

ANTENNA

Antenna coverage for DBS is either elliptical as represented by the WARC '77 assignments in Regions 1 and 3 or irregularly shaped as exemplified by U. S. time zone coverage. Figure 2 shows U. S. service areas with modified time zone boundaries which are roughly equal in area when seen from four satellites (one per zone) located at 115° West longitude (W), 135°W, 155°W and 175°W (Ref. 1). Equal areas enable the use of equal power TWT⁵. Shaped beam antennas will be required to maximize gain and low sidelobes and crosspol will be required to minimize interference to adjoining regions.

The technology, both software and hardware, has been demonstrated at Ku-band by a study performed for NASA Langley by TRW (Ref. 2). Figure 3 shows the shaped beam antenna geometry for the coverage of the true Eastern Time Zone as seen from a satellite located at 98°W. Linear polarization enables the use of a vertical grid subreflector so that the aperture can be reused and all four time zones can be implemented as shown. An offset parabolic reflector with a 2.3 meter diameter (D), a 25 horn feed and an F/D = 1.25 is employed. The resulting directivity contours are shown in Figure 4. Coverage is roughly at the -2 dB contour and the gain slope around the contour is uniform and roughly 10 dB/degree providing low susceptibility to attitude control errors. Special pains have been taken to control sidelobes so that a -35 dB level is achieved at the border of the Central Time Zone to enable frequency reuse.

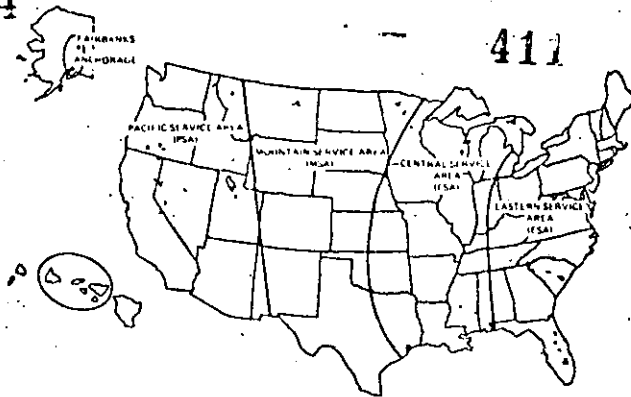


Figure 2. Conus Service Areas and Coverage of Alaska and Hawaii

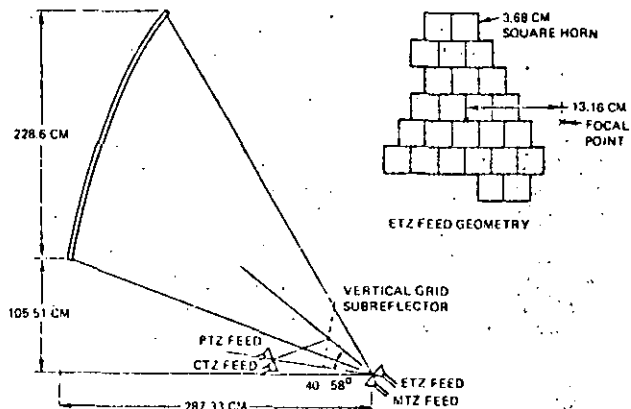


Figure 3. Contoured Beam Antenna Configuration

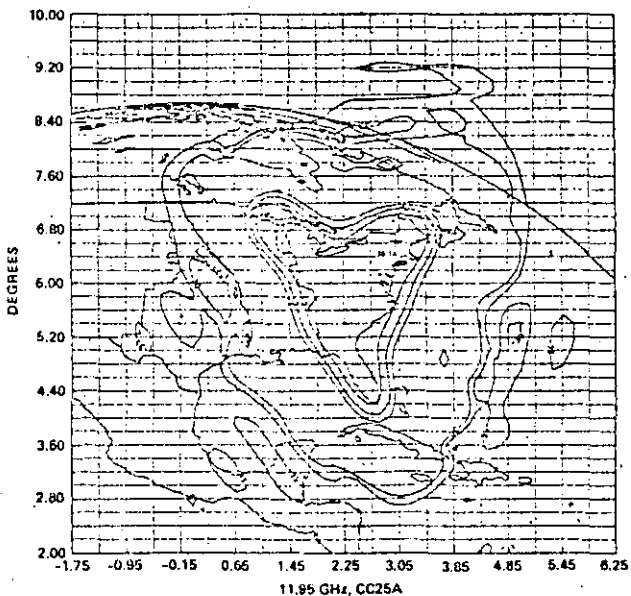


Figure 4. Beam Isolation Contours at 11.95 GHz

Additional horns are used around the periphery of the feed network for this purpose (Ref. 7).

The software technology is illustrated by a comparison of calculated and measured results shown in Figure 5. There is good agreement in contour and sidelobe structure to about the -20 to 25 dB level. Lower level sidelobes and crosspol must be verified by measurements employing good mechanical simulations of actual spacecraft installation. Figure 6 is a photograph of the 25 horn feed which was built and tested. Note that the antenna was designed for both transmit and receive across the 11.7 to 14.5 GHz band. Uniform results were obtained across the band.

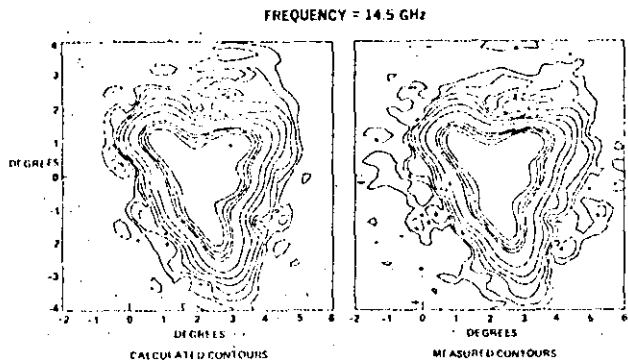


Figure 5. Comparison of Calculated and Measured Gain Contours

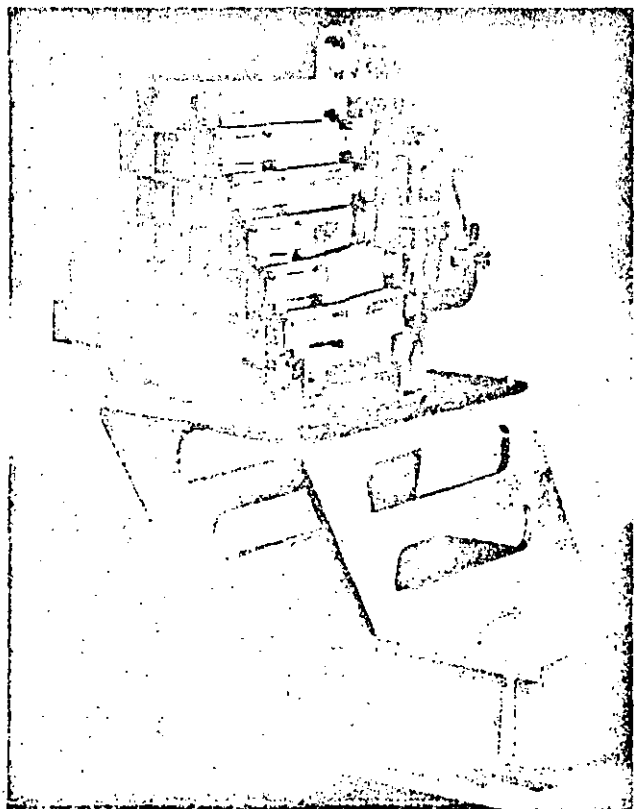


Figure 6. ETZ Feed Cluster

U. S. DBS satellites will most probably use circular polarization and each satellite will provide 3-6 channels to one of the service areas at 12 GHz as defined above. Each satellite antenna will be designed to cover two service areas from the designated orbital locations for the purpose of in-orbit sparing. Uplinking at 18 GHz

will be from the Las Vegas/Los Angeles area. Figure 7 shows the antenna layout and feed geometry for an Eastern type satellite which can cover either the Eastern Service Area from 115°W or the Central Service Area from 135°W. In addition, a separate set of feeds in four horn monopulse arrangement is provided for the Las Vegas uplink and RF sensing. In this case the antenna designer has been constrained to work with an $F/D = 0.9$ for spacecraft mechanical design reasons. Antenna directivity contours are shown on Figure 8 for the Eastern Service Area. Again, excellent coverage at the -2 dB contour and sidelobe control have been obtained.

It is noteworthy that mini-max computer optimization programs have been implemented to weight the antenna gain distribution as a function of a set of gain requirements. This technique can be used to provide additional gain to rainy areas assuming equal home receiver G/T or to equalize RF power budget margins assuming graduated values of home receiver G/T as a function of rain.

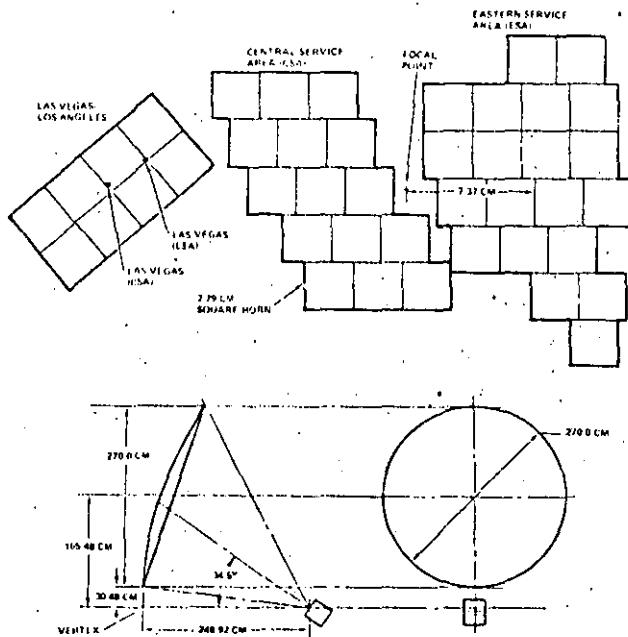


Figure 7. Eastern/Central Satellite Antenna Configuration

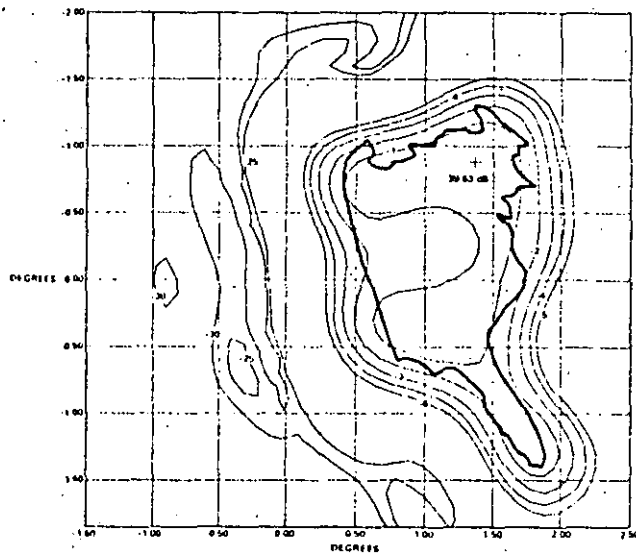


Figure 8. Antenna Directivity Contours Spacecraft at 115°W

TABLE 4. TRAVELING WAVE TUBES FOR DBS

As noted in Table 1, for Luxembourg, the minimum beamwidth of 0.6 degree specified for Regions 1 and 3 of WARC '77 leads to a diameter of roughly 3.3 meters using the relationship

$$D = \frac{80\lambda}{BW} \quad (1)$$

to achieve a 30 dB first sidelobe. This diameter exceeds the available space in the Ariane 3 shroud and in the vertical-in-shuttle installation. Figure 9 shows an unfurlable design being engineered at TRW which will be available both in center fed and offset geometries. General Dynamics is working on a competing truss design aimed at larger apertures.

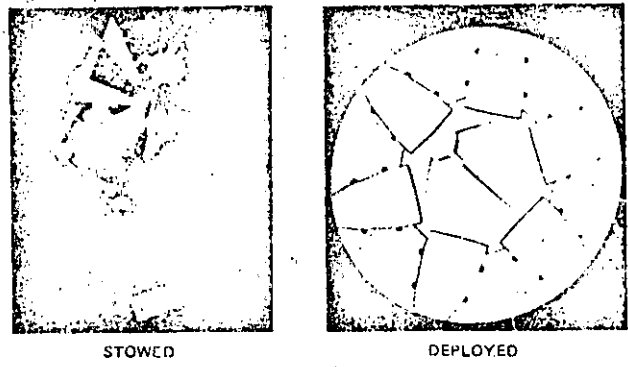


Figure 9. Six Main Panel Reflector Furling Concept

TRAVELING WAVE TUBES

The traveling wave tube amplifier (TWTA) is the only high power amplifier presently under development for the 12 GHz DBS application. A promising high power klystron development was funded for a number of years by the German government at the Valvo Company in Hamburg but this was dropped. This device performed well in the neighborhood of 1 kw RF output.

Solid state devices at 12 GHz are limited to a few watts and amplifiers are under development with up to 20 watt outputs. This is clearly insufficient for DBS requirements.

The TWTA consists of two distinct parts: the TWT and the EPC (electronic power conditioner). These units are built by different groups and usually by different companies. For the TWT power levels of interest, the two leading suppliers are Thomson CSF (Ref. 3) in France and AEG-Telefunken (Ref. 4) in Germany. Hughes Electron Dynamics Division and Litton have built DBS TWT⁵ in the past but have fallen behind because of lack of U. S. government support. By contrast, both the French and German governments have provided significant funding to enable high power TWT development.

Table 4 summarizes some of the principal features of TWT⁵ for DBS projects. It includes the two outdated U. S. tubes for completeness. Note that the technology has progressed dramatically in a few key areas. The dividing line for use of a helix instead of a coupled cavity for the slow wave structure at 12 GHz has increased from the 60 watt region (Hughes K-Band Shuttle TWT) to the 250-280 watt region. The helix tube is generally cheaper, more compact, and lighter. (Note the lighter weights for the four European tubes.) It is generally a broader bandwidth device although this is not at all clear from Table 4. Instantaneous bandwidth is rigorously that bandwidth over which guaranteed performance is maintained. The entries in Table 4 are nominal or typical.

The design lifetime is claimed to be improved because of the use of an impregnated cathode similar to those used on 20 watt 12 GHz tubes operated at the same temperature and emission density. Thomson and Telefunken both have had extensive life test programs ongoing for many years. Unfortunately, there is almost no orbital life data for 200 watt helix tubes. Hence, a prudent spacecraft designer will incorporate as much redundancy as weight will allow.

The thermal design has improved dramatically as evidenced by the collector/body dissipation ratio. The early tubes had the collector radiating 40% of the heat dissipated directly to space while 60% was conducted to a radiator panel. This has been improved to a

	30 150W THOMSON CSF	250 200W THOMSON CSF	250 200W AEG TELEFUNKEN	250 200W AEG TELEFUNKEN	250 200W HUGHES	250 200W LITTON
REFLECTOR	HELIX	HELIX	HELIX	COUPLED CAVITY	COUPLED CAVITY	COUPLED CAVITY
NO. OF ELEMENTS	3	4	5	5	3	18
NOMINAL EFFICIENCY (%)	58	48	45	58	58	48
INSTANTANEOUS BANDWIDTH (MHz)	700	100,000	100,000	100,000	100	85
DESIGN LIFE (years)	5.7	5.7	5.7	5.7	3	3
COLLECTOR HEATING	RADIATION	RADIATION	RADIATION	RADIATION	RADIATION	RADIATION
COLLECTOR BODY DISSIPATION PERCENT	40.00	70.00	70.00	70.00	40.00	40.00
WAVELENGTH	2.0	2.5	3.1	3.0	3.0	3.0
PROGRAM	HS 2	EDI 3	TVSAT		JBS 1	CTS
STATUS	ADVANCED DEVELOPMENT	ADVANCED DEVELOPMENT	ADVANCED DEVELOPMENT	ENGINEERING MODEL	FLYING	FLYING

70/30 percent collector to body dissipation ratio. This makes the spacecraft thermal job much easier.

Note that the 200 watt tubes are both in advanced development for the Franco-German DBS project. In fact, the French and German satellites will carry a mixed complement of French and German tubes.

For the HDTV project proposed by CBS a 450-watt RF output is desired. This can be achieved either by paralleling two 230-watt tubes (which will have been qualified) or by completing the development and qualification of the 450 watt tube. Paralleling TWT⁵ has been previously done both terrestrially and in space and has been resorted to for much the same reason. Namely, when a higher power is needed and there exists a well tested device at roughly half the required power. Paralleling is generally heavier and more costly, and there are combining losses of 0.3-0.5 dB. Generally, the circuit is mechanized in a 3 for 2 redundancy configuration.

Note that Hughes EDD is still a viable high power TWT supplier and should not be ruled out as a tube source. Litton, however, has dropped this line of business.

ELECTRONIC POWER CONDITIONER

The design of Electronic Power Conditioners (EPC) for high power TWT⁵ is distinguished by the requirement to handle high voltage. For the DBS class amplifiers these voltages can be as high as 15 kilovolts. For the tubes of interest, very few companies have built EPC⁵. AEG-Telefunken in Backnang is currently developing EPC⁵ for both the Thomson and Telefunken 230 watt/275 watt tubes. AEG is also breadboarding a power supply for the 450 watt tube. General Electric built the power supplies for the Hughes JBS-1 tube and is redesigning the supply for the Thomson JBS-2 tube. TRW built the EPC for the Litton 200 watt tube used on the Communications Technology Satellite (CTS) (Ref. 5).

Orbital experience is sparse and is mixed. All three TWT⁵ on JBS-1 failed within a few months of each other. There is evidence to suggest that all failures were attributable to arcing in the high voltage section of the EPC. This in turn could be caused by a deterioration of the potting material. General Electric is presently working on a fix for the potting process for the JBS-2 mission.

The experience on CTS was completely successful. CTS continued to operate past its three year lifetime until it was turned off. The TRW EPC avoids the problem of potting deterioration by using an open construction. The same technique has been incorporated successfully in a number of TWT designs eliminating the potting in the collector region thus avoiding arcing problems.

Figure 10 is a photograph of the CTS TWTA. It was built as an experiment and was integrated and tested by TRW. The maximum high voltage supply was 11.3 kv, the nominal unregulated bus power was roughly 80 VDC and the nominal efficiency was 89%.

Figure 11 presents EPC specific mass in kg/kw as a function of EPC power output for a number of power supplies. Unfortunately data is sparse and some is preliminary. CTS (modified) is an estimate of the CTS EPC as it might be for an operational mission with four to five collectors instead of 10. The AEG TV-Sat is an early estimate and could well increase by the time it is qualified. The Siemens 450 watt TWTA was a breadboard performed for a German technology program.

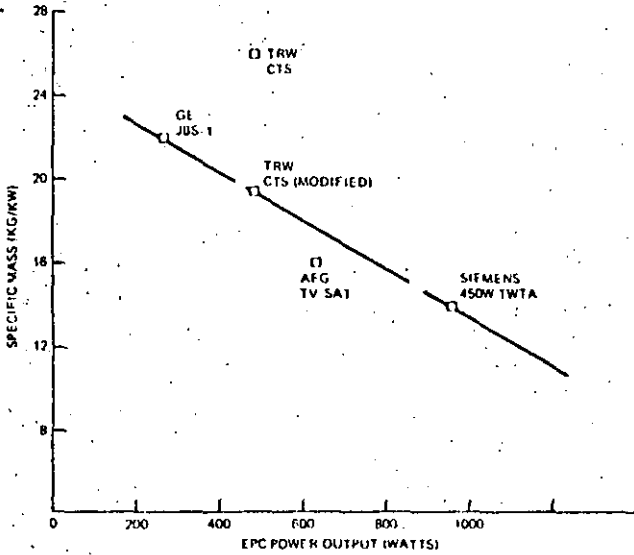


Figure 10. TWT Electronic Power Conditioner (EPC) Specific Mass



Figure 11. Transmitter Experiment Package (TEP) for Communications Technology Satellite

SOLAR ARRAY

Near term DBS missions show solar array requirements ranging from 1 to 5 kilowatts (kw) at 7-10 year equinox.

State of the art using silicon cells is exemplified by the performance curves shown in Figure 12. Note that these curves are indicative of performance values and can vary by 5 to 15% as a function of specific cell and cover glass, radiation degradation, temperature, installation losses and harness losses. The curves have been normalized using identical parameters and, hence, may differ somewhat from manufacturer's data.

The MBB/ULP (ultra lightweight panel) (Ref. 6) has been qualified using a 1 kw wing under contract to Intelsat. It is not being used as yet in any space project. Performance is shown for various panel widths and conventional and thin cells and cover glass. Conventional cells are defined as 10 ohm-cm back surface reflecting, efficiency of 11.9% at 28°C, cell thickness of 0.2 mm and fused silicon cover glass with a thickness of 0.1 mm. Thin cells have the same efficiency with a thickness of 0.05 mm and a cover glass thickness of 0.05 mm. MBB has tested the array with both conventional and thin cells.

Thin cells and cover glass are not yet in production but manufacturers are willing to bid for production contracts. First users will have to pay for initial tooling costs and learning. Thin cells would be applicable to any of the arrays shown in Figure 12.

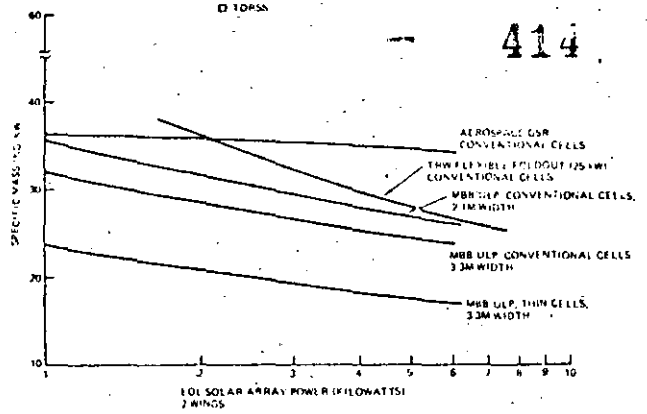


Figure 12. Solar Array Specific Mass

The various solar panel widths are indicative of practical installation limitations as a function of launch vehicle and spacecraft size. The full 3.3 meters width could be applicable to a horizontal STS installation or a full use of the Ariane shroud. Smaller satellites using a vertical installation in Shuttle or a shared Ariane 3 launch would be restricted to a smaller panel width and a heavier weight.

The Aerospatiale GSR (Générateur Solaire Rigide) (Ref. 7) is being used on the Franco-German DBS as well as on Arabsat. Note that as used with European cells and for the European project groundrules its performance is closer to 38 kg/kw rather than 35 kg/kw as shown in Figure 12 for 4 kw. This is for a 3.6 meter panel width. For a 2.05 meter panel width the performance is about 7% lower.

The flexible foldout array has been under development at TRW and Lockheed in conjunction with NASA high power applications of 25 kw or higher. Extrapolation of this technology to the 2.5 kw level puts it at a disadvantage with respect to the ULP array. In addition, both the GSR and ULP arrays have exposed panels in their stowed configurations and, hence, can provide some power in transfer orbit. The flexible foldout is stowed in a container and requires partial deployment to provide transfer orbit power. Partial deployment is generally applicable only to a 3-axis stabilized ascent and may be difficult for a spin stabilized ascent.

Figure 13 is a photograph of a portion of the TRW ultra light-weight solar array undergoing engineering testing.

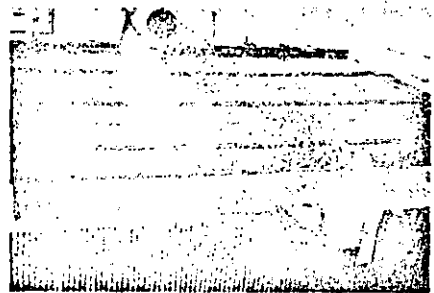


Figure 13. TRW Ultra Light Solar Array

HEAT PIPE RADIATORS

Thermal control for DBS spacecraft will often resort to the use of heat pipe radiators because of the high heat dissipation caused by the communications equipment and because the distribution of the active TWTA's on the North and South panels can cause significant heat load variations. Figure 14 illustrates a particularly complex system implementation for the NORDSAT (Refs. 8 and 9) Model A spacecraft designed by TRW. The total radiator area has been minimized by thermally coupling the North, South and top (Earth facing) panel using variable conductance heat pipes (VCHP). Thus, all three radi-

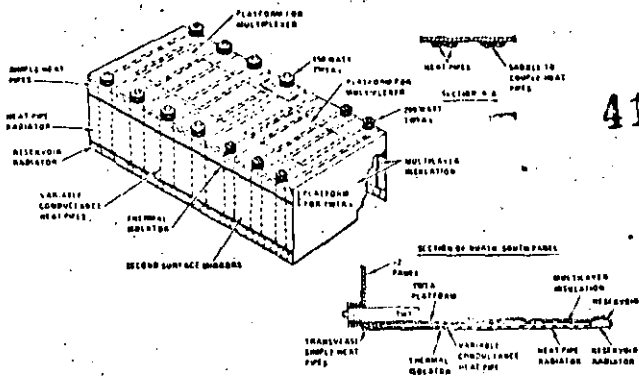


Figure 14. NORDSAT Payload Module Thermal Design

ators share in the heat rejection, regardless of which combination of TWTA^s are active. There are also simple heat pipes on both the North and South panels used to spread the heat in the direction normal to the VCHP^s. During eclipse, when the TWTA^s are off, the VCHP^s "turn-off" or deactivate over 50 percent of the radiator area preventing the equipment from getting too cold. A very similar design was proposed for use on the Franco-German DBS program.

Analyses indicate that benign conditions can be established for the high power equipment maintaining temperatures between 20 and 45°C during operation and above -10°C during non-operating eclipse conditions.

Simple and variable conductance heat pipes have been successfully flown on many geosynchronous missions including ATS-6 and CTS and are considered passive devices. A photograph of the CTS heat pipe radiator built and integrated by TRW is shown in Figure 15.

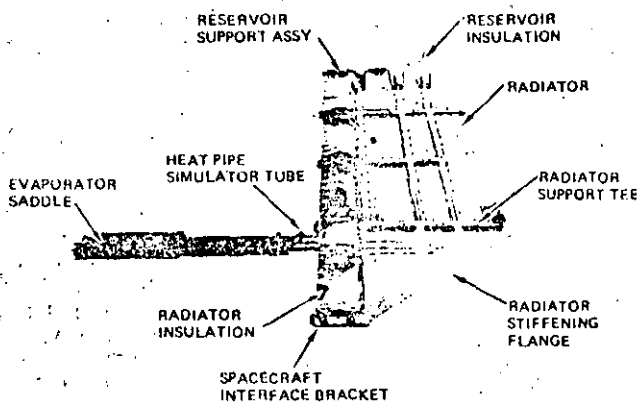


Figure 15. Communication Technology Satellite Variable Conductance Heat Pipe System

which was assigned channels 22, 24, 26, 28, 30, 32, 36, and 40. This required the use of a contiguous band multiplexer wherein the non-zero in-band reactance of a filter can be used to compensate for the out-of-band reactance of the adjacent channels. Matching requires that all channel filters have similar impedance characteristics, which implies that all have the same number of poles, same design bandwidth and same channel separation.

Table 5 shows the insertion loss of some of the filters considered for the NORDSAT output multiplexer.

TABLE 5. OUTPUT FILTER INSERTION LOSS

TYPE OF FILTER	MIDBAND INSERTION LOSS (dB)	
	EVEN (OR ODD) 3-POLE MAXIMALLY FLAT FILTER	CONTIGUOUS 4-POLE TSCHERBYSCHEFF FILTER
TE ₁₀₁	1.40	2.00
TE ₁₀₃	0.96	1.37
TE ₁₀₅	0.72	1.03
TE ₁₁₁	1.40	2.00
TE ₁₁₃	0.43	0.61
TE ₀₁₁	0.35	0.50

A TE₀₁₁ (mode) 4 channel filter (shown in Figure 16) was bread-boarded and tested and an unloaded Q of 20,000 was realized. An eight channel contiguous output multiplexer (Ref. 10) was designed, including four additional filters, for matching (as shown in Figure 17) Computer simulations were run producing a transmission response shown in Figure 18. A thermal design and analysis was performed showing that invar is required to help provide a dimensionally stable filter and that heat must be removed from both ends of the filter. Tests showed that an aluminum tuner and tuner plate are required to compensate for cavity length change under full dissipation.

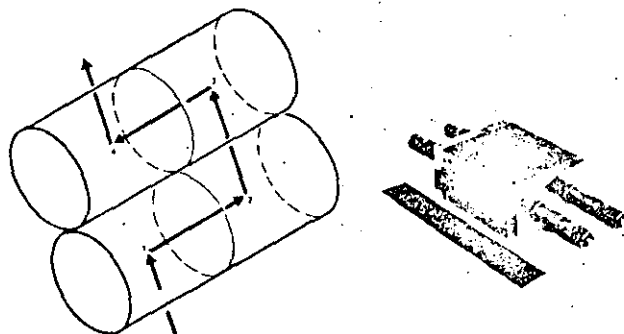


Figure 16. 4 Pole Tschebyscheff (TE₀₁₁) Mode Filter

OUTPUT MULTIPLEXER

The filter problem unique to DBS is the high power handling requirement in the output multiplexer. The filter insertion loss can lead to high thermal dissipation with TWT output levels up to 450 watts. Assuming the use of state of the art high Q filters such as TE₁₁₃, the key parameter limiting insertion loss is the filter design bandwidth. The wider the bandwidth, the lower the insertion loss. The wider the channel spacing, the wider the allowable design bandwidth.

Channel spacing and assignments have still to be made for Region 2 at the RARC '83 conference. Regions 1 and 3 assigned 27 MHz channels on 38 MHz centers at WARC '77. Most countries were assigned widely spaced channels such as 1, 5, 9, etc., for France, considerably easing the output multiplexer thermal problem. However, a more difficult spacing was assigned to NORDSAT (Ref. 8)

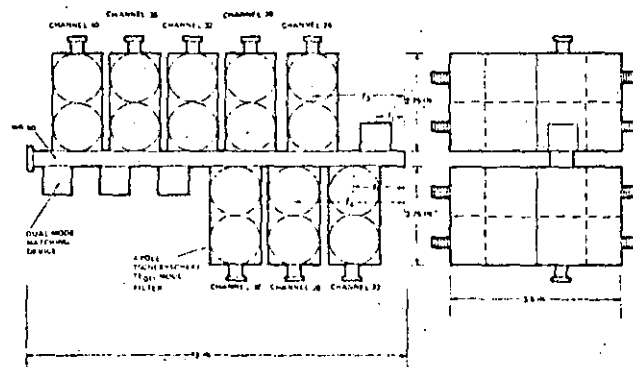


Figure 17. Eight Channel Contiguous Multiplexer

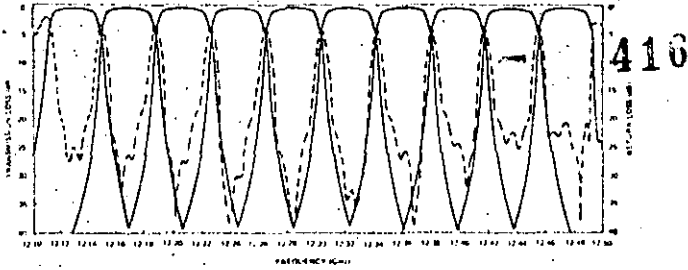


Figure 18. Multiplexer Transmission Response

Multipaction refers to high voltage breakdown in vacuum which is generally a function of the product of frequency and electrode separation. Analysis techniques are available (Ref. 11) and analysis performed for NORDSAT (Ref. 8) revealed a potential problem at 450 watts for the TE₀₁₁ filter to manifold coupling slot. A possible solution is widening of the slot width. However, analytical modeling is not sufficiently accurate. Hence, high power testing of all critical microwave hardware will be standard operating procedure for DBS satellite programs.

CONCLUSION

Technology required for near term DBS missions has been surveyed. It is concluded that the technology is available and only detailed engineering development and test is required for DBS construction.

REFERENCES

1. "Application of the Satellite Television Corporation for a satellite-to-home subscription television service," before the Federal Communications Commission, Washington, D. C., December 17, 1980.
2. C. C. Chen, C. F. Franklin, "Ku band multiple beam antenna," prepared for NASA Langley Research Center, NASA Contract Report 154 364, December 1980.
3. J. Collomb, A. Pelletier, H. Raye, "Performance results and interface considerations for a 200-230W, 12 GHz DBS TWT," Thomson-CSF, AIAA 9th Communications Satellite Systems Conference, San Diego, California, March 1982.
4. D. Deml, Kalscon, Malzahn, "New satellite TWT^s for 12, 20 and 30 GHz systems and associated life consideration," AEG-Telefunken, AIAA 9th Communications Systems Conference, San Diego, California, March 1982.

5. E. F. Miller, J. L. Fiala, I. G. Hansen, "Performance characteristics of the 12 GHz, 200 watt transmitter equipment package for CTS," Lewis Research Center, IEEE, Washington, D. C., October 1975.

6. K. Schneider, "Development and testing of the ULP solar array," Proceeding of the European Symposium on Photovoltaic Generators in Space, ESTEC, Noordwijk, September 1978, ESA SP-140 (November 1978)

7. Gerard Barkats, "Development of a fold-out rigid solar array for 3-axis-stabilized geosynchronous satellites," Aerospatiale, Cannes, France, Internal Paper.

8. "NORDSAT spacecraft models and critical subsystems study," Final Report, March 1979, TRW, prepared for the Norwegian Telecommunications Administration, Kjeller, Norway.

9. H. D. Cohen, "Shuttle launched NORDSAT satellites," TRW, Montreux TV Broadcast Symposium, June 1979.

10. M. H. Chen, F. Assal, C. Mahle, "A contiguous band multiplexer," Comsat Technical Review, Volume 6, No. 2, Fall 1976.

11. R. Woo, "Final report on RF voltage breakdown in coaxial transmission lines," Jet Propulsion Laboratory Technical Report 32-1500, October 1970.

BIOGRAPHY

Herbert D. Cohen, B.A., Brooklyn College; M.S., Stanford University.

Mr. Cohen is currently a senior systems engineer in the Space and Technology Group of TRW. He has been with TRW since 1955, and has been working on satellite design during most of that period. He was on assignment in Europe for 8 years, managing TRW support of satellite design by private companies and government agencies. Since his return from Europe in 1973, Mr. Cohen has specialized in advanced system design activities for communication satellites. His experience in DBS projects started prior to 1965 with internal company projects and includes funded studies for the French and German governments in the late 60^s and consultancy to the German DFVLR in 1972-73. He headed a NORDSAT DBS system study for the NORDIC Telecommunications Administrations in 1978-79. He presently leads DBS system engineering work at TRW. He contributes to the work of CCIR JWG 10-11S on DBS and the FCC Advisory Committee on preparation for RARC '83.

MAILING ADDRESS

Herbert D. Cohen, Bldg. R-5, Room 1020 TRW, Inc., One Space Park, Redondo Beach, California 90278.

3.2 ESTRUCTURA BASICA DE UN SATELITE

En esta sección se describen las principales características físicas y el funcionamiento de los subsistemas que integran a un satélite artificial. La confiabilidad del equipo empleado es de suma importancia ya que se desea recibir y transmitir información ininterrumpidamente por varios años (de 5 a 7 años que es la vida típica de diseño de un satélite). Una vez lanzado el satélite, la posibilidad de reparación queda excluida; por esta razón, varios de los subsistemas que lo integran se montan por duplicado (subsistemas redundantes) y se conmutan ya sea "en línea" automáticamente, ó bien por medio de comandos transmitidos desde la tierra. Los principales subsistemas de un satélite son los siguientes:

- Antenas
- Transpondedores
- Seguimiento
- Telemetría
- Comando
- Control de posición
- Corrección de órbita
- Alimentación

En la figura 1 se muestra la distribución de cada subsistema dentro del cuerpo del satélite.

ANTENAS

En la figura 2 se muestra el subsistema de antenas del INTEL SAT IV. Posee cuatro cornetas cónicas de iluminación global y dos antenas parabólicas para iluminación con haz pincel. El diseño de las cornetas es idéntico en los cuatro casos, únicamente escalado a la frecuencia apropiada, ya que dos de ellas

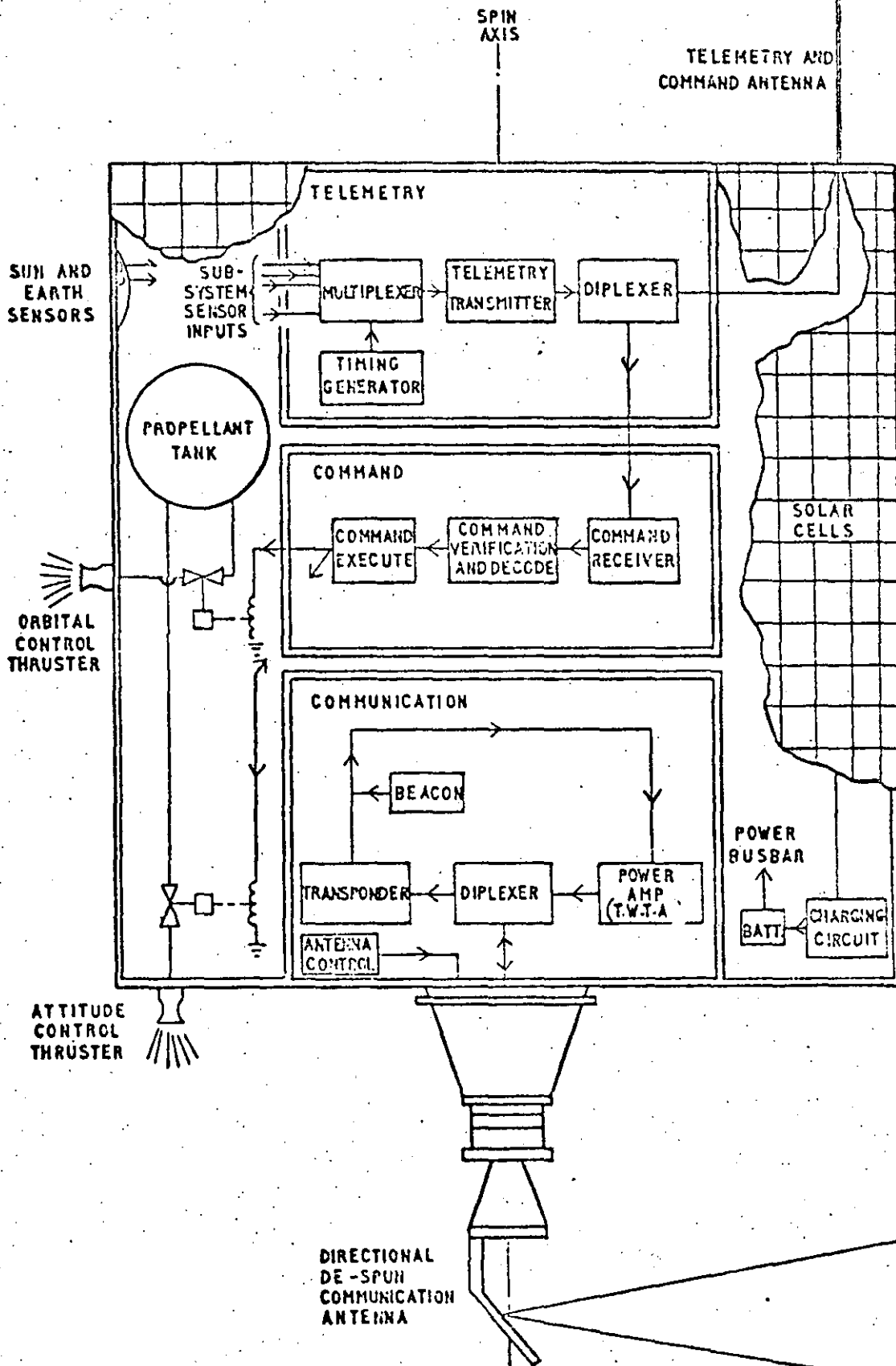


FIG. 1 TYPICAL SATELLITE SUB-SYSTEMS.

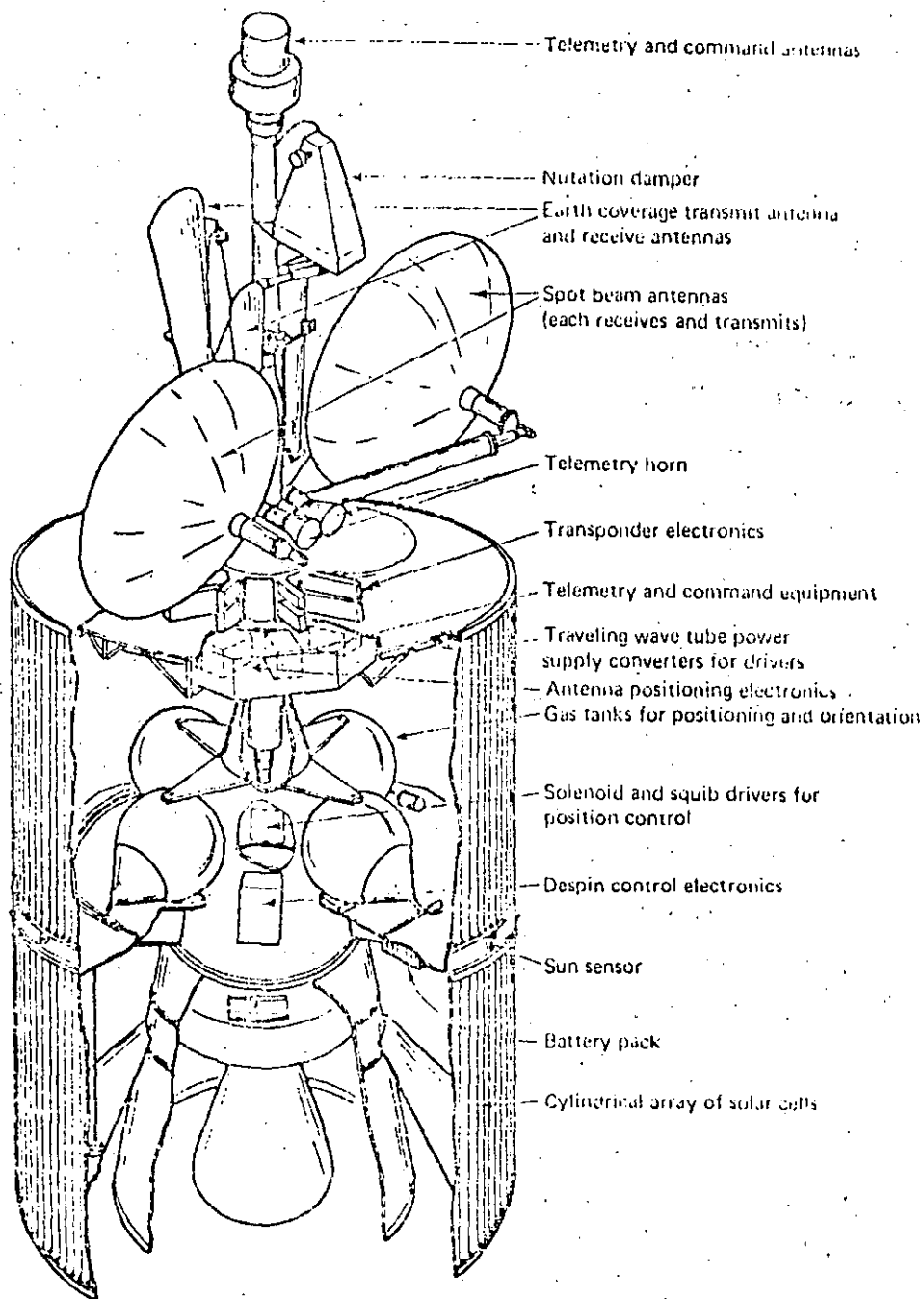


FIG. 2

The structure of INTELSAT IV.

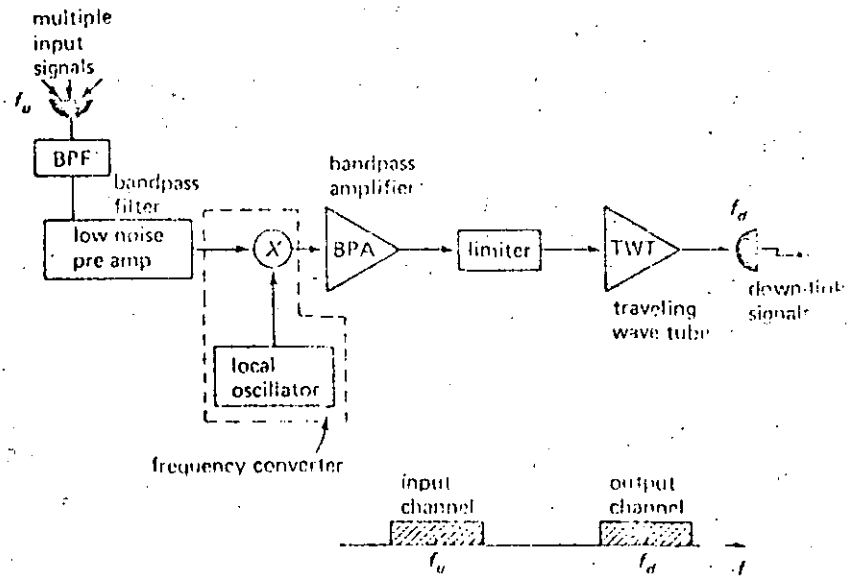
reciben a la frecuencia de subida y las otras dos transmiten a la frecuencia de bajada. El ángulo de la sesga es de 6° y cada corneta se monta con su eje paralelo al eje de rotación del satélite, provista de un plato elíptico reflector que dirige la energía proveniente de la tierra a la boca de la corneta, ó bien dirige la energía que desea transmitirse hacia la tierra.

Las antenas parabólicas de haz pincel son provistas de un mecanismo que permite cambiar su orientación en órbita. El reflector tiene un diámetro de aproximadamente 1.2 m. y una razón $F/D = 0.422$, lo cual da una ganancia aproximada de 28 dB a frecuencias en la banda de 4 GHz. El alimentador es una corneta cónica con sesga de 10° , y el ancho del haz es de 4.5° .

Tanto las cornetas como las antenas parabólicas operan con polarización circular.

TRANSPONEDORES

La mayoría de los satélites de comunicaciones contienen varios (cuatro ó más) transpondedores en paralelo, frecuentemente con varias antenas de haz angosto ó pincel. En la figura siguiente se muestran los elementos más básicos de un transpondedor típico. A la antena receptora llegan varias señales senoidales dentro de la banda con frecuencia central f_{subida} y después de pasar por las diferentes etapas del transpondedor, bajan a través de la antena transmisora a frecuencias que caen dentro de la banda con frecuencia central f_{bajada} . Las dos bandas tienen una separación adecuada para evitar interferencia ó traslape entre ellas. En este ejemplo, se tiene una sola etapa de traslación de frecuencia, en donde las señales recibidas de RF se convierten y amplifican directamente a la frecuencia de RF de transmisión. Existen otras confi



Simplified transponder block diagram showing a single channel transponder

guraciones en donde las señales se bajan primero a una frecuencia intermedia conveniente, por ejemplo 150 MHz, y después de amplificarlas se suben a la frecuencia de transmisión; estas configuraciones se conocen como de doble conversión y gran parte de la amplificación puede realizarse en FI por medio de transistores.

Los transpondedores de una sola conversión como el de la figura anterior generalmente emplean dos amplificadores TWT en cascada.

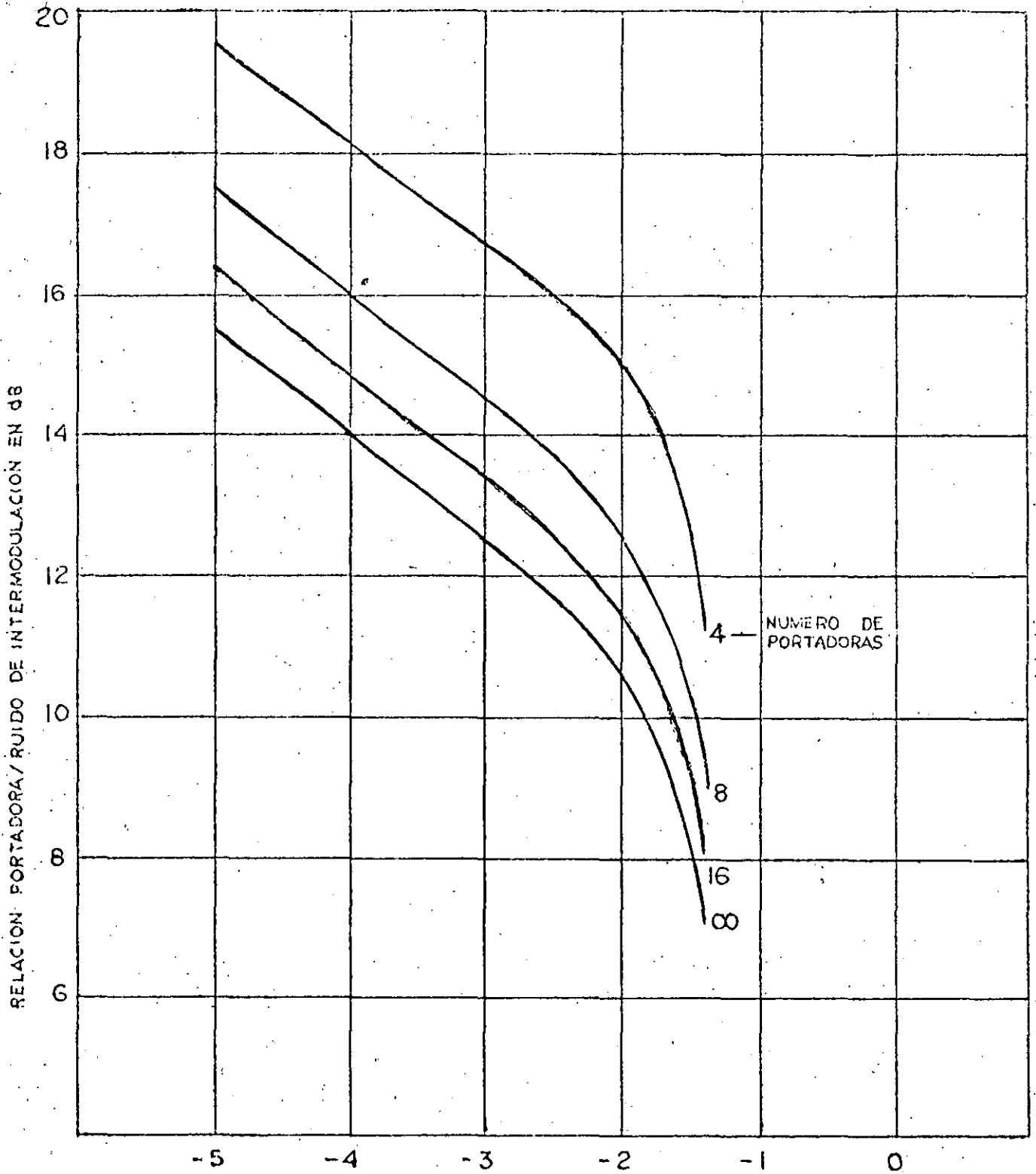
La característica de amplificación de los tubos de onda progresiva (TWT) es no lineal, y para evitar la introducción de altos productos de intermodulación, se requiere operar el amplificador con varios decibeles de "back-off" de salida, lo cual reduce la eficiencia del mismo. A continuación se muestra la curva característica de la razón potencia de la portadora/potencia de ruido de intermodulación en función del back-off de salida, para un TWT típico, así como la configuración simplificada del subsistema de 12 transpondedores del satélite Intelsat IV.

SEGUIMIENTO O RASTREO

El satélite contiene un dispositivo que genera una señal de identificación en codificación binaria, misma que se transmite continuamente a la tierra a través de un transpondedor ó del transmisor de telemetría, para que las estaciones terrenas puedan rastrear el satélite.

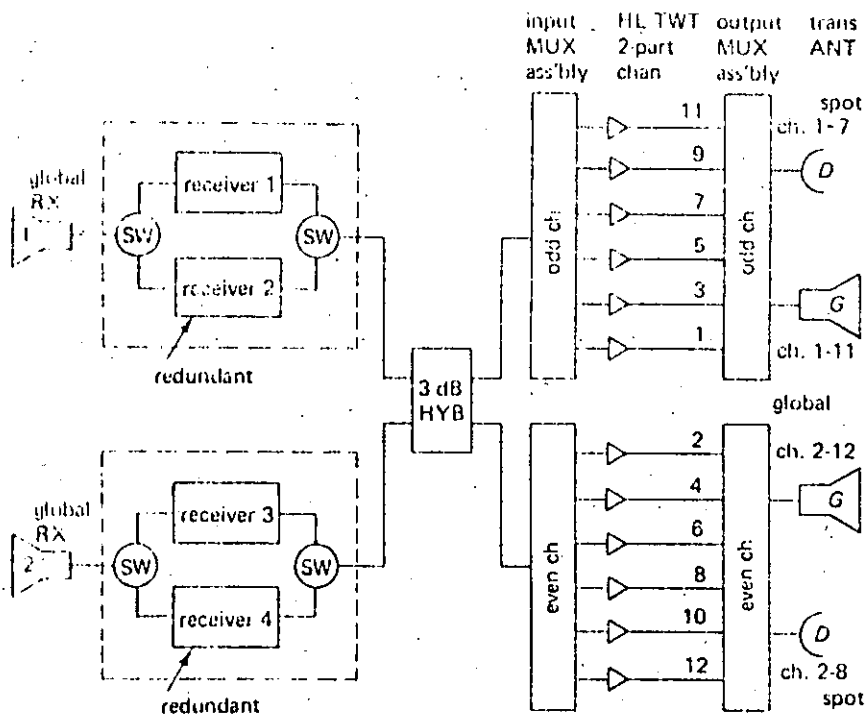
TELEMETRIA

Este subsistema consiste de un transmisor que envía la infor

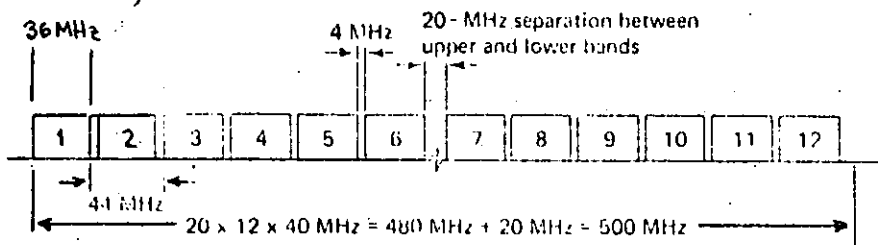


BACK-OFF DE SALIDA DE UN AMPLIFICADOR T.W.T. EN dB

RELACION PORTADORA/RUIDO DE INTERMODULACION EN
FUNCION DEL BACK-OFF PARA UN AMPLIFICADOR T.W.T. TIPICO.



(a)



(b)

Simplified configuration of the INTELSAT IV satellite transponder [After Bennett and Dostis, 1974, 375] (a) transponder block diagram, (b) transponder frequency plan

mación colectada de varios sensores hacia la tierra para el monitoreo del satélite. Los principales parámetros sensados son:

- Presión de los tanques de combustible
- Voltaje y corriente de diferentes subsistemas
- Potencia consumida por los subsistemas
- Temperatura de la estructura
- Estado de operación de equipos redundantes.

COMANDO

Consiste de un receptor con circuitería adecuada de decodificación que transfiere señales de ejecución a los diferentes subsistemas. Estas señales son originadas en tierra de acuerdo a los datos existentes de seguimiento y telemetría.

Nota: Una estación terrena adicional ejecuta las funciones de seguimiento, telemetría y comando (conocida como T.T.&C. ground station, Telemetry, Tracking and Command). Las bandas de frecuencias empleadas pueden caer dentro de las categorías siguientes, de acuerdo al tipo de satélite:

- (a) 137-138 MHz Telemetría y seguimiento
148-149.9 MHz Telecomando
- (b) 400.15-401 MHz Telemetría y seguimiento
375 MHz Telecomando
- (c) 2.29-2.30 GHz Telemetría y seguimiento
1.76-1.84 GHz Telecomando

Las antenas empleadas a bordo son omnidireccionales de tal forma que pueda haber comunicación permanente con el satélite

independientemente de su posición relativa con respecto a la tierra.

CONTROL DE POSICION

Este subsistema corrige la orientación del cuerpo del satélite, de las antenas y de las celdas solares.

CORRECCION DE ORBITA

Este subsistema consiste de propulsores que modifican la posición orbital del satélite cuando se ha desviado más allá de los límites permisibles, como efecto de las fuerzas gravitacionales del sol y la luna. Este subsistema, además, coloca al satélite en órbita geostacionaria durante el lanzamiento.

ALIMENTACION

Consiste de un arreglo de celdas solares en combinación con baterías recargables, redundantes. Generalmente, cada batería consiste de 16 celdas de 1.3 volts cada una, conectadas en serie.

En las páginas siguientes se anexa información sobre el sistema mexicano Morelos de satélites domésticos.



427

**DIVISION DE EDUCACION CONTINUA
FACULTAD DE INGENIERIA U.N.A.M.**

TELECOMUNICACIONES VIA SATELITE

CARACTERISTICAS TECNICAS DEL SISTEMA DE SATELITES DOMESTICO
MEXICANO - SISTEMA MORELOS

JUNIO, 1984.

CARACTERISTICAS TECNICAS DEL SISTEMA DE SATELITES

DOMESTICO MEXICANO

SISTEMA MORELOS

El Sistema Morelos consistirá de dos satélites domésticos mexicanos situados en órbita geoestacionaria a 113.50 y 116.50 longitud oeste. Estos satélites serán construidos por la compañía Hughes de California, Estados Unidos, en base a su modelo de satélite HS 376. Las características de ambos satélites son similares y se listan a continuación.

Número de Transpondedores por satélite	Banda C 12 de 36 MHz c/u 6 de 72 MHz c/u	Banda Ku 4 de 108 MHz c/u
PIRE por transpondedor en saturación, en cobertura nacional.	39.0 dBW en polarización horizontal (72 MHz) 35.5 dBW en polarización vertical (36 MHz)	44.0 dBW
G/T, en cobertura nacional	Por definirse para polarización horizontal - 2.0 dB/°K para polarización vertical	1.0 dB/°K
Densidad de flujo para operar en saturación.	<p>Transpondedor de 36 MHz:</p> <p>- 69 dBW/m² Ajustable en incrementos de 3.0 ± 0.25 dB dentro del rango de - 69 dBW/m² a - 80 dBW/m².</p> <p>Transpondedor de 72 MHz:</p> <p>- 66 dBW/m² Ajustable en incrementos de 3.0 ± 0.25 dB dentro del rango de - 66 dBW/m² a - 77 dBW/m².</p>	<p>- 60 dBW/m² ± 0.5 dB.</p>

Plan de frecuencias y polarización de los satélites domésticos mexicanos, para la banda C.

Transponder Channel	Downlink		Uplink	
	Center Frequency, MHz	Polarization*	Center Frequency, MHz	Polarization
1 (WB)	3740	H	5965	V
2 (WS)	3820	H	6045	V
3 (WB)	3900	H	6125	V
4 (WB)	3980	H	6205	V
5 (WB)	4060	H	6285	V
6 (WB)	4140	H	6365	V
7	3740	V	5965	H
8	3780	V	6005	H
9	3820	V	6045	H
10	3860	V	6085	H
11	3900	V	6125	H
12	3940	V	6165	H
13	3980	V	6205	H
14	4020	V	6245	H
15	4060	V	6285	H
16	4100	V	6325	H
17	4140	V	6365	H
18	4180	V	6405	H

*H = horizontal polarization, V = vertical polarization. Horizontal polarization shall be parallel to the velocity vector of the spacecraft. Vertical polarization shall be perpendicular to the velocity vector of the spacecraft.

Estabilización	Sobre su propio eje
Dimensiones	2.16 m diámetro 6.60 m altura
Masa en órbita	666 Kg.
Potencia para operación normal	940 watts c.d. producidos por celdas solares
Potencia para operación en casos de eclipse	830 watts producidos por baterías de níquel-cadmio
Lanzador	Transportador espacial, abril y septiembre, 1985
Vida de diseño	10 años

* Cada satélite, dada sus características de repetidor en el espacio, podrá utilizarse con técnicas de modulación analógicas o digitales y modos de acceso múltiple por división en frecuencia (FDMA) o en tiempo (TDMA). SCPC/DAMA es una de las alternativas en FDMA.

- 1 transpondedor de 36 MHz tendrá capacidad para cualquiera de las siguientes aplicaciones:
 - 800 circuitos telefónicos, usando canales SCPC analógicos de 22 KHz.
 - 400 circuitos telefónicos, usando canales SCPC digitales PSK de 2 ó de 4 fases de 45 KHz.
- 2 canales de TV
- Transmisión de datos a 60 Mbits/seg.
- Otros variantes o alternativas

ESTACIONES TERRENAS

TIPOS DE ESTACIONES TERRENAS.

Las estaciones terrenas se clasifican en diferentes categorías dependiendo del servicio que prestan: Estaciones Terrenas para el Servicio de Satélite Fijo, Estaciones Terrenas Móviles (las que se emplean a bordo de barcos y aeronaves) y Estaciones Portátiles.

En esta sección se hará énfasis en las Estaciones Terrenas para Servicio de Comunicación por Satélite Fijo.

1.- ESTACION TERRENA ESTANDAR

Una Estación Terrena que opera en base a un acceso múltiple se le llama Estación Terrena Estandar.

Las Estaciones Terrenas que operan en la banda de frecuencias de 4-6 GHz y las cuales tienen una figura de mérito (razón de la ganancia de la antena a la temperatura de ruido) superiores a 40.7 dbk a un ángulo de operación específico a la antena de la estación terrena, se le conoce como una Estación Terrena de norma A y aquellas que tienen una $\frac{G}{T}$ de aproximadamente 31.7 dbk se les conoce como Estaciones Terrenas de norma B. Cuando la estación terrena opera en la banda de frecuencias de 14/11 GHz y satisface los valores especificados de $\frac{G}{T}$ se les llama Estaciones Terrenas de norma C.

Las características de funcionamiento de las estaciones terrenas estandar se dividen en dos categorías, requisitos de mandato y requisitos recomendados.

432

El primero incluye características en aprobación da da para la estación terrena estandar y la segunda da características de funcionamiento deseable para la operación eficiente del satélite y desarrollos futuros de la estación terrena. En principio se basan en las características técnicas que se encuentran en las recomendaciones y reportes del CCIR.

La Tabla (1) muestra los requisitos de mandato para las estaciones terrenas estandar A, B y C. Las estaciones terrenas que tienen características de funcionamiento inferiores a las que se especifican en la Tabla (1) se llaman Estaciones Terrenas No Estandar. A dichas estaciones se les puede conceder temporalmente el acceso a segmentos de espacio con algunas restricciones en su operación.

	Estación terrena norma A		Estación terrena norma B		Estación terrena norma C
7 Polarización	satélite	covertura	Transmisor de la est. terrena	Receptor de la est. terrena	Polarización lineal, ortogona para transmitir y recibir. La polarización en los haces puntuales este y oeste son ortogonales
	INTELSAT IV y IVA	Global, puntual (IV) y hemisférico IVA	LHCP	RHCP	
	INTELSAT V	Global hemisferio Oeste hemisferio Este Zona 1 (Oeste) Zona 2 (Este)	LHCP LHCP LHCP RHCP RHCP	RHCP RHCP RHCP LHCP LHCP	
8 Razón axial de la antena	Para INTELSAT IV y IVA : inferior a 1.4 Para INTELSAT V : Estaciones terrenas que deben acceder a los transponders del haz global debido a sus restricciones de ubicación geográfica ... inferior a 1.4 antenas existentes (reuso de frecuencia) inferior a 1.09 nuevas antenas (reuso de frecuencia) inferior a 1.06				433
9 Estabilidad de la EIRP	dentro de ± 0.5 dB del valor nominal				
10 Tolerancia de frecuencia portadora	Todas las portadoras de FDM-FM a excepción de las portadoras de 1.25, 2.5 y 5.0 MHz dentro de ± 150 KHZ Portadoras de 1.25 MHz dentro de ± 40 KHZ Portadoras de 2.5 y 5.0 MHz dentro de ± 80 KHZ Portadora de 5.0 MHz dentro de ± 80 MHz Portadoras SCPC dentro de ± 250 KHZ Portadoras de TV dentro de ± 250 KHZ		Portadoras FDM-FM dentro de ± 80 KHZ Portadoras SCPC: dentro de ± 250 KHZ Portadoras de TV dentro de ± 250 KHZ		Portadoras FDM-FM: Idem que estaciones terrenas de norma A

Tabla 1 Características de funcionamiento de estaciones terrenas estandar INTELSAT

	Estación terrena de norma A	Estación terrena norma B	Estación terrena norma C
Ancho de banda	Ancho de banda de transmisión Ancho de banda de recepción	5.925 - 6.425 GHZ 3.7 - 4.2 GHZ	Ancho de banda de Tx 14.0-14.5 GHZ Ancho de banda de Rx 10.95-11.20 GHZ 11.45-11.70 GHZ
Razón de ganancia a temperatura de ruido G/T	G/T 40.7+20 log f/4 (dbk) Nota 1: f es la frecuencia de recepción expresada en GHZ Nota 2: Los términos L ₁ y L ₂ representan la atenuación relativa esperada con un cielo despejado, a la frecuencia de interés, excedida por no más de P ₁ =10.0 y P ₂ =0.017%	G/T 31.7+20 log f/4 (dbk)	G/T ₁ -L ₁ A+20 log f/11.2 (dbk) para todo tiempo, excepto P ₁ G/T ₂ -L ₂ B+20 log f/11.2 (dbk) para todo tiempo excepto P ₂ A = 39.0 B = 29.5 (puntual oeste), 32.5 (puntual este)
Ganancia de antena		Superior a 53.2dB (a 6 GHZ)	
Patrón del lóbulo lateral de la antena (transmisión)	$1^\circ < \theta \leq 48^\circ : G(\theta) \leq 32 - 25 \log \theta \text{ (dB)}$ $\theta > 48^\circ : G(\theta) \leq - 10 \text{ dB}$		434
	<p>Nota 1: θ es el ángulo en grados entre el eje del haz principal y la dirección considerada</p> <p>Nota 2: No deben de exceder por más del 10% de los picos del lóbulo lateral a una envolvente descrita por estas expresiones a un ángulo mayor de 1° medido desde el eje del haz principal. Para antenas de norma A existentes que accesan los satelites INTELSAT IV y IVA, o aquellas que estaran operando antes del 1^o de enero de 1985, se aplica una condicion de tolerancia.</p>		
Acceso Multiple	FDMA	FDMA	FDMA
Tipos de modulación	FDM/FM (canales telefonicos, SCPC-PCM/PSK (voz, canales telegraficos, y datos a baja velocidad) SCPC-PSK (canales de datos) FM (canales de televisión)	FDM-FM (canales de TV con audio) SCPC-PCM-PSK (voz, canales telegraficos y datos a baja velocidad) SCPC- Fsk (canales de datos) FM (canales de TV)	FDM - FM

Continúa Tabla 1

	Estación terrena norma A	Estación terrena norma B	Estación terrena norma C
1. Emisión de RF fuera de banda (productos de intermodulación)	Intermodulación entre portadoras FDM/FM incluyendo Portadoras de TV y entre SPADE o SCPC preasignadas y cualquier otra portadora no SEPC o SPADE		Inferior a 12 (dBW/4KHZ)
	Covertura	Límite a un ángulo de elevación de 10°	Factor de corrección para otros ángulos de elevación
	Hemiterico y de zona	23 dBW/4 KHZ	-0.02 (-10) (dB)
	Global (SCPC)		-0.06 (-10) (dB)
	Global	26 dBW/4 KHZ	
	Intermodulación entre portadoras SCPC:		
	Modulación tipo de portadoras	Límite a un ángulo de elevación de 10°	Factor de corrección para otros ángulos de elevación
	SCPC-PCM-PSK y SCPC- FSK	33(dBW/4KHZ) para $2 \leq N \leq 7$ 50-20 log N(dBW/4KHZ) para $N > 7$	-0.06 (-10) (dB)
	1. α es el ángulo de elevación de la estación terrena en grados		
	2. N es el número total de canales SCPC configurados		
2. Nivel de emisión de espureas(excluyendo productos de intermodulación)	Inferior a 4 (dBW/4KHZ)		

435

Es obligatorio para las estaciones terrenas normales, ecualizar la distorsión por retardo de grupo de los transponders del satélite. Esto se desarrolla en el transmisor de la estación terrena. La máxima ecualización permitida se muestra en la Tabla (11).

ANCHO DE BANDA (MHz)	ANCHO DE BANDA ECUALIZADA (MHz)	ECUALIZACION LINEAL (ns/MHz)	EGUALIZACION PARABOLICA (ns/MHz ²)
1.25	1.125	0 ± 10	0 - 2
2.5	2.25	0 ± 10	0 - 2
5	4.5	0 ± 5	0 - 2
7.5	6.75	0 ± 5	0 - 1
10.0	9.0	0 ± 5	0 - 1
15.0	13.5	0 ± 5	0 - 0.5
17.5	15.75	0 ± 3	0 - 0.5
20.0	18.0	0 ± 2	0 - 0.5
25.0	22.5	0 ± 2	0 - 0.5
36.0	36.0	0 ± 1	0 - 0.25

TABLA (11). Ecualización en el Transmisor de la Estación Terrena requerido para retardo de grupo por Satélite.

2.- FACILIDADES DE UNA ESTACION TERRENA

2.1.- CONFIGURACION DE UNA ESTACION TERRENA

Una estación terrena generalmente cuenta con facilidades de comunicaciones de transmisión terrestre, de potencia y un edificio de control. Las facilidades de comunicaciones se subdividen en:

- a) Subsistema de antena
- b) Subsistema del amplificador de transmisión
- c) Subsistema de amplificación del receptor
- d) Subsistema equipo de comunicación de tierra (GCE)
- e) Subsistema de equipo terminal, y
- f) Subsistema de control de comunicaciones.

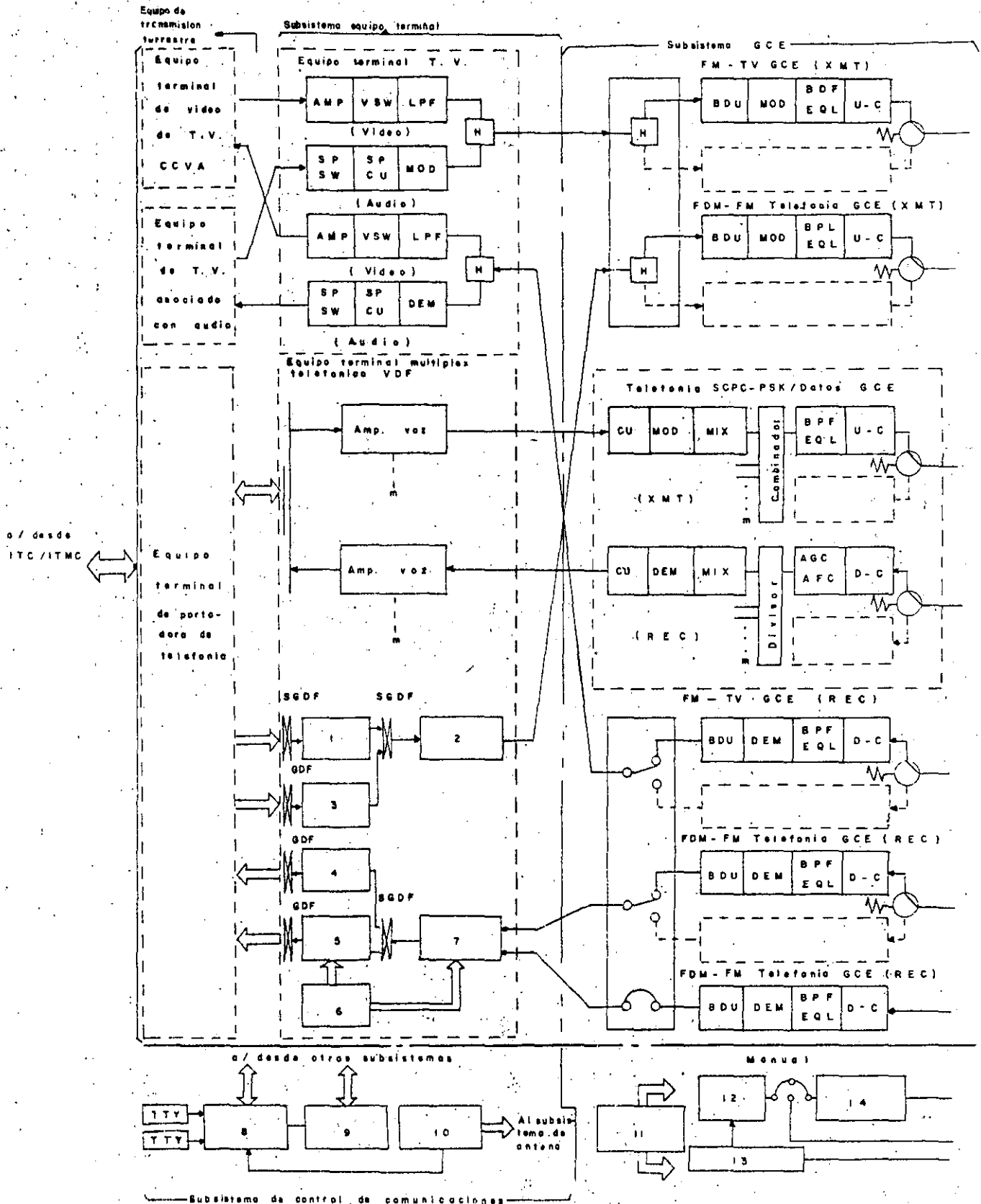
La figura (1) muestra un diagrama a bloques de una configuración típica de una estación terrena de norma A para el satélite INTELSAT V.

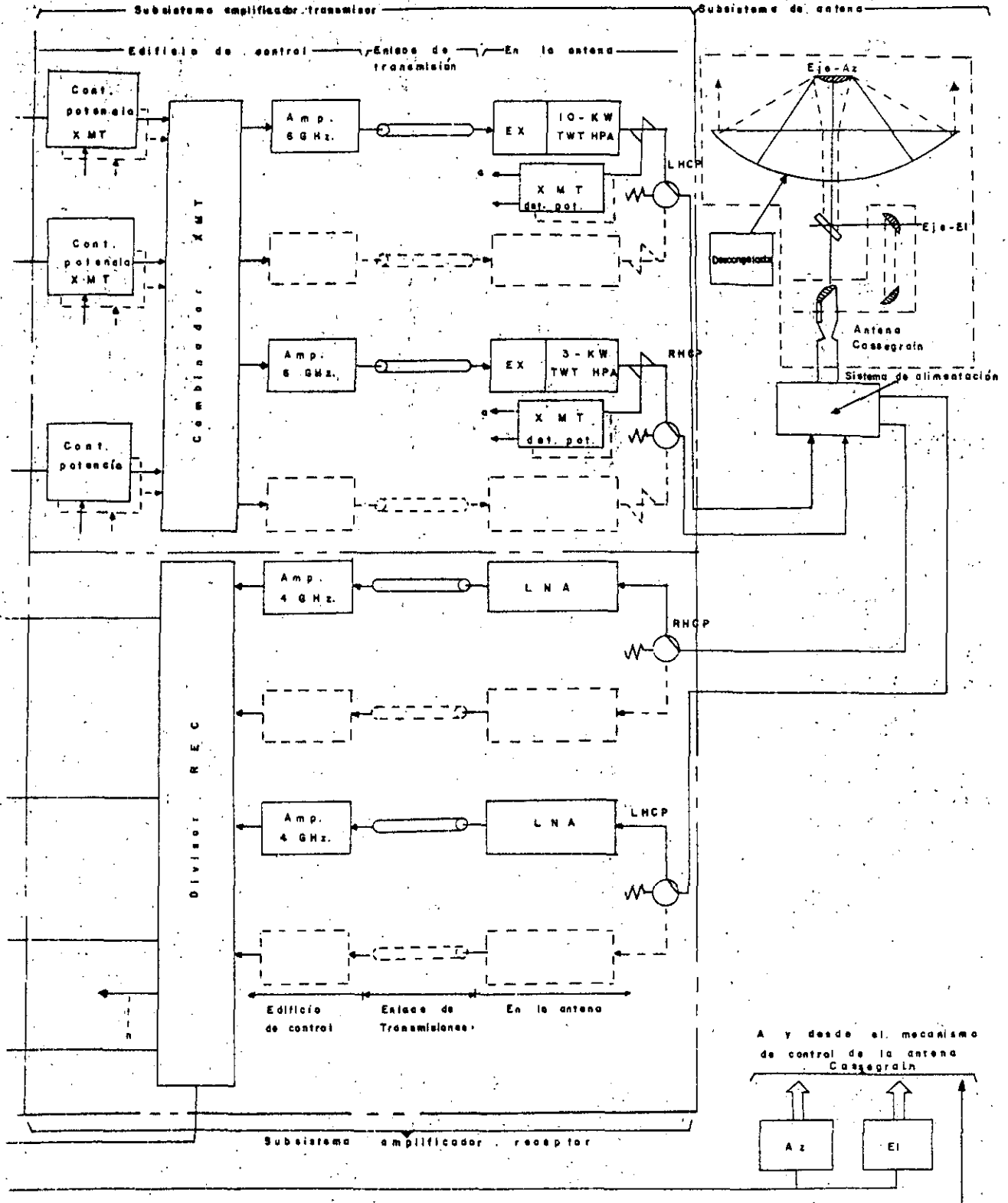
2.2.- FACILIDADES DE COMUNICACION

En los siguientes párrafos se hará una descripción de las facilidades del subsistema de comunicaciones.

1) Subsistema de Antena

La antena se emplea para rastrear el satélite para transmitir las señales de comunicación eficientemente y para recibir las señales débiles que provienen del satélite. La antena es generalmente del tipo Cassegrain, la cual consiste de un reflector principal y de un sub-reflector, un alimentador, un equipo para medir la posición, un equipo de rastreo,





etc. La antena que se muestra en la Fig. (1) es del tipo - - Cassegrain alimentada por medio de una guía de onda de cuatro reflectores. Esta antena esta equipada con un sistema de -- alimentación para polarización ortogonal con el fin de permitir el acceso al satélite INTELSAT V.

2) Subsistema de Amplificador del Transmisor

Generalmente se requiere de una estación terrena -- que proporcione la capacidad de transmitir una o más portadoras simultáneamente. Hay dos sistemas bien conocidos para -- amplificar las portadoras múltiples: uno es el sistema de -- amplificación común en el cual se emplea un amplificador de -- alta potencia (HPA) el cual es empleado para amplificar las -- portadoras múltiples, y el otro es el sistema de amplifica -- ción individual en el cual las portadoras múltiples son ampli -- ficadas por HPA's independientes con potencia de salida compa -- rativamente baja, y las señales de salida de estos amplifica -- dores individuales se combinan a través de un combinador de -- potencia.

(a) Sistemas de Amplificación Común

El Subsistema de Amplificador de Transmisión, el -- cual se muestra en la figura (1) muestra un ejemplo de su con -- figuración para la operación de polarización ortogonal en el -- cual las portadoras de transmisión son amplificadas en una -- base de amplificación común empleando un par de amplificado -- res de alta potencia uno para la polarización circular de -- mano izquierda (LHCP) y el otro para la polarización circular -- de mano derecha (RHCP). Cada amplificador de alta potencia -

estos amplificadores se combinan mediante un combinador de tipo híbrido o un combinador tipo filtro. Un combinador de tipo híbrido convencional origina 3 db de pérdida de potencia cada vez que se combinan 2 señales de entrada. Sin embargo, recientemente se ha desarrollado un combinador de razón de potencia, el cual permite la variación de pérdidas de 1 a 7 db (7 al 1 db para el puerto opuesto). La pérdida de un combinador de tipo filtro es del orden de 1 db, pero este tipo tiene una desventaja que presenta una pequeña banda muerta en la banda de frecuencia de transmisión. El sistema de amplificación individual requiere un ancho de banda un poco más angosto para cada HPA. Esto permite el empleo de Klystron, los cuales son menos costosos que los TOP's.

3) SUBSISTEMA AMPLIFICADOR DEL RECEPTOR

Este subsistema consiste principalmente de receptores de bajo ruido (LNR's), enlaces a 4 GHz, amplificadores asociados y un divisor, para la operación con polarización ortogonal como en el INTELSAT V. Deben instalarse dos conjuntos de LNR's, uno para RHCP y uno para LHCP.

Con el fin de reducir la temperatura de ruido del sistema receptor se requiere emplear un circuito de guía de onda de pequeña longitud a la entrada del LNR y usar un receptor que tenga una baja temperatura de ruido.

4) SUBSISTEMA GCE

Este subsistema se puede clasificar en equipo para los sistemas telefónicos FDM - F.M y Televisión en F.M y --

equipos para el sistema SCPC-PSK.

442

(a) GCE para el Sistema de F.M.

Como se muestra en la fig. (1) el equipo empleado en los sistemas GCE para el sistema F.M incluye moduladores de F.M (MOD) y conversores de frecuencia de transmisión, (U-C) para la trayectoria de transmisión así como para los conversores de recepción (D-C) y demoduladores de F.M. (DEM) para la trayectoria de recepción. Una de las funciones más importantes del subsistema GCE es que las frecuencias y los niveles de las portadoras de R.F. en enlace por satélite pueden cambiarse rápidamente sin una interrupción considerable de servicio. Para cumplir estos requisitos se emplean U-C y D-C del tipo de doble conversión y se usa un oscilador local sintetizado en lugar de un oscilador a cristal. Además se utiliza un ecualizador de satélite (EQL) para la preigualación de las características de retardo de grupo de los transponders de satélite en el circuito BPF/EQL del GCE de transmisión como se muestra en la fig. 2.

El número de GCEs para la trayectoria de recepción en la estación terrena generalmente es más grande que las de la trayectoria de transmisión debido al múltiple destino de sistema de portadoras empleadas para los enlaces telefónicos FDM-F.M. en el sistema INTELSAT. En algunos casos especialmente para enlaces por satélite de pequeña capacidad, los GCEs son instalados sin redundancia.

(b) GCE para el sistema SCPC-PSK

El sistema SCPC-PSK es uno de los sistemas de trans

se acompaña por un amplificador de alta potencia redundante - para propósitos de seguridad. En este ejemplo, un circuito de control de nivel automático (ALC) se emplea para cada portadora para evitar fluctuaciones de los niveles de portadora amplificadas y que se transmitirán debido a que las portadoras múltiples son generalmente amplificadas por un HPA después de que se han combinado en un combinador de portadora de transmisión. El circuito de ALC consiste de un detector de potencia de transmisión que sirve para detectar la potencia de salida del HPA y un controlador de potencia del transmisor que sirve para controlar el nivel de potencia del transmisor a la entrada del HPA. Las facilidades de comunicación instaladas en el edificio de control y los HPA's que se encuentran en la antena se conectan por un enlace de transmisión. Dicha configuración es generalmente adoptada en muchas estaciones terrenas de gran tamaño.

En este sistema el TOP se emplea generalmente como un amplificador de alta potencia. Cuando las portadoras múltiples se amplifican simultáneamente, se generan a la salida del HPA producto de intermodulación debido a la no linealidad del TOP. Con el propósito de mantener el ruido y la emisión fuera de banda que resulta de esta intermodulación por abajo de valores específicos, generalmente se operan los TOP's con suficiente punto de operación (BACK-OFF). Debe emplearse un compensador de intermodulación si se requiere una supresión más rigurosa de intermodulación.

(b) Sistema de Amplificación Individual

En este sistema, se emplean HPA's independientes --

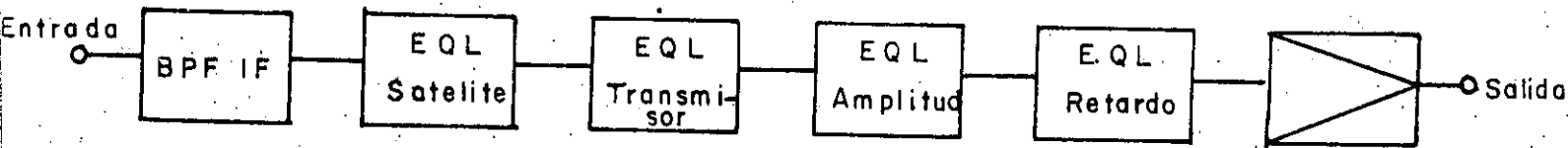
~~521~~ 444

Fig. 2. Diagrama a bloques de un circuito BPF/EQL del transmisor en el subsistema GCE.

tienen pequeño tráfico y una alta velocidad de transmisión de datos tal como 48 - 50 ó 56 Kbits/seg. las cuales se han --- empleado ampliamente en el sistema INTELSAT.

El equipo SCPC-PSK consiste de un bastidor de canal y un bastidor común tal como se ilustra en la fig. (1). El bastidor de canal incluye la unidad de canal (C-U), el modulador (MOD), Demodulador (DEM) y el mezclador de frecuencia (MIX) que están proporcionados a cada canal. El bastidor -- común consiste principalmente de U-C, D-C y Diplexers. La -- trayectoria de recepción de el bastidor común tiene un circuito AFC/AGC para desarrollar control automático de frecuencia (AFC) y un control automático de ganancia (AGC) de la señal -- recibida al recibir una señal piloto de referencia asignada -- al centro de la banda del SCPC. Para el circuito a nivel de voz, las unidades de canal incluyen además de otros circuitos --

445

detectores para controlar la operación de las portadoras para la activación de voz, circuitos de sincronía, etc.

5) SUBSISTEMA DE EQUIPO TERMINAL

El subsistema de equipo terminal de la estación --terrena tiene una función de interconectar el enlace por satélite y los enlaces terrestres. Puede comprender equipo terminal de multicanalización telefónica ó equipo terminal de televisión para la señal de video, equipo para la señal de televisión asociada con audio dependiendo del modo de transmisión.

(a) Equipo Terminal de Multicanalización Telefónica

Este equipo consiste de amplificadores de voz trasladadores de grupo y super grupo, fuentes de portadoras, etc. es capaz de proporcionar interfase entre enlaces por satélite y enlaces de transmisión terrestre en la cual se hace la conversión del arreglo de banda base de las portadoras con destino múltiple para el enlace por satélite en el arreglo que acomode el canal, el grupo ó el super grupo. Este equipo es --altamente confiable así que no se requiere redundancia.

(b) Equipo Terminal de Televisión

El equipo terminal de televisión instalado en la --estación terrena está interconectado en el enlace por satélite con el circuito terrestre que conecta el centro de televisión internacional (ITC) y la estación terrena. Consiste del equipo terminal de video que tiene una función de conmutar el circuito y compensarlo para las características de transmi---sión, el equipo de audio asociado con televisión para multi--

canalizar la señal de video con la de audio, y la consola de control de televisión. Además los conversores estandar de televisión se instalan en muchas estaciones terrenas para cumplir con los requisitos especificados para la transmisión de televisión internacional.

6) SUBSISTEMA DE CONTROL DE COMUNICACION

Este subsistema consiste principalmente del equipo de monitoreo para supervisar el estado de otros subsistemas descritos anteriormente, enlaces terrestres y el equipo de control para conmutar los equipos en operación y en reserva. Además el reloj de tiempo estandar el cual proporciona el tiempo de referencia para la estación terrena y el equipo de circuito de servicio de ingeniería (ESC) para manejar la información operacional con otras estaciones terrenas ó la oficina central que también está incluida en este subsistema.

2.3 BOSQUEJO DE LAS FACILIDADES DE LA ESTACION TERRENA

(I) Consideraciones en el Bosquejo de las Facilidades.

De acuerdo con el bosquejo de las facilidades de la estación terrena se consiven dos métodos: El primero es el de acomodar las facilidades de comunicación en dos sitios separados, la antena y el edificio de control, mientras que el otro es instalar todas las facilidades en un edificio que sirve como el pedestal de la antena y el edificio de control. La selección entre estas dos alternativas debe determinarse de acuerdo a la escala de la estación y su conveniencia operacional.

Actualmente se emplean en estaciones terrenas de gran tamaño dos tipos de sistemas de antenas, en uno de ellos se emplea una antena CASSEGRAIN en el campo cercano, el LNA se instala en el local del receptor el cual contiene el ensamblaje alimentador y el HPA se instala generalmente en el pedestal de la antena como se muestra en la figura (3). Dado que es difícil encontrar suficiente espacio en el pedestal de la antena y el cuarto del receptor, otras facilidades de comunicación diferentes al HPA y al LNA son inevitablemente instalados en un edificio de control separado.

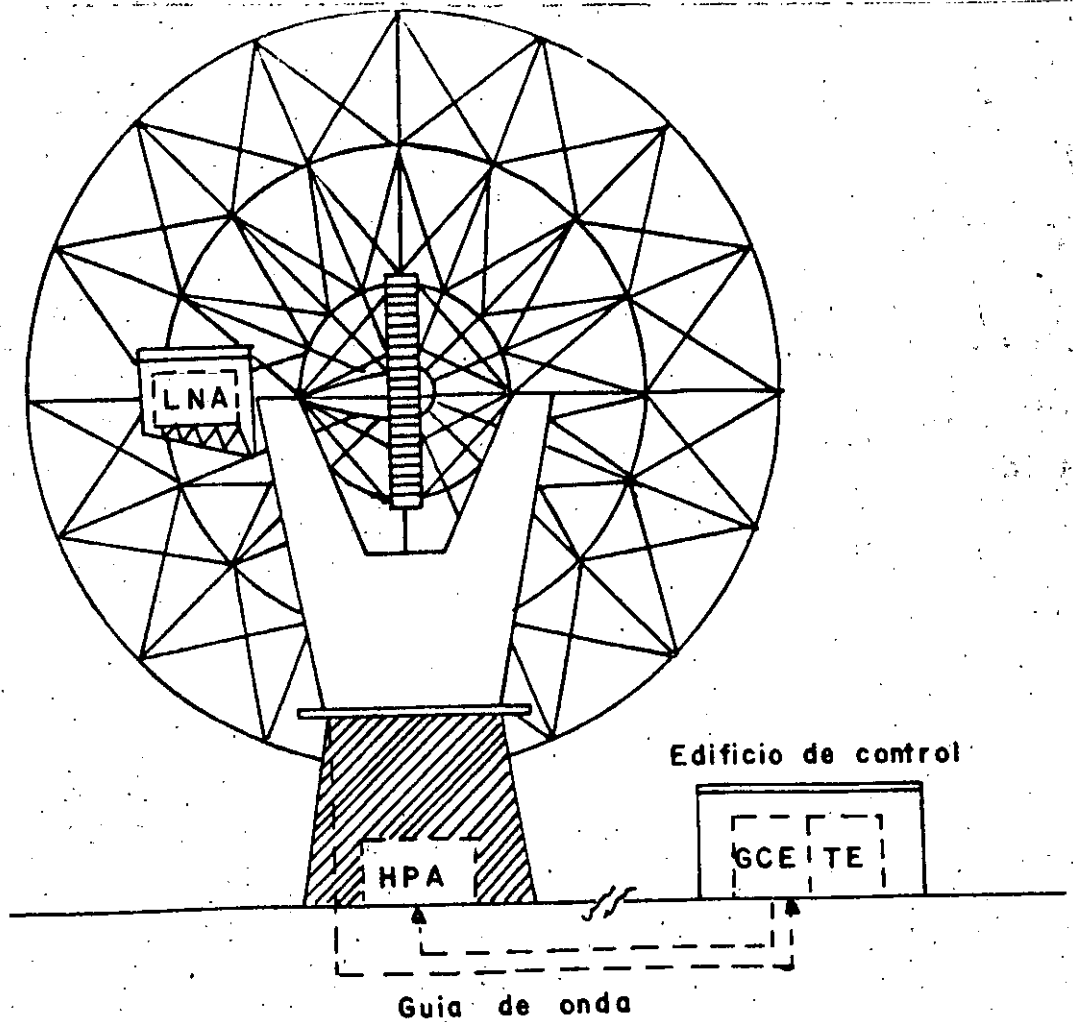


Fig. 3 Estación terrena de gran tamaño que emplea una antena tipo Cassegrain.

El otro tipo de antena CASSEGRAIN emplea la alimentación del haz guiado y no solamente presenta alto rendimiento, sino que también tiene el mérito de fácil operación y mantenimiento debido a que el ensamble de alimentación, el LNA y el HPA pueden instalarse en tierra. Recientemente los subsistemas GCE, terminales asociados y equipo de control tienden a instalarse en el edificio de control para el caso de estaciones terrenas de gran tamaño, mientras que en las estaciones terrenas pequeñas, todos los subsistemas se instalan en el edificio de la antena.

(2) FACILIDADES DEL ENLACE DE TRANSMISION

En el caso donde la antena es construida en un sitio diferente del edificio de control, se requieren sistemas de transmisión de señal entre el sitio de la antena y el edificio de control. Se consideran las siguientes alternativas; (i) Un sistema de transmisión de banda base, (ii) Un sistema de transmisión en F.I, (i, i, i) Un sistema de transmisión de Microondas, (i,v) Un sistema de transmisión por fibra Optica. De los sistemas anteriores el de microondas es ampliamente empleado en la estación terrena porque es flexible para la expansión del destino y para la introducción de nuevos sistemas de comunicación sin dificultad, proporciona la capacidad de fácil mantenimiento y operación.

(3) ESTACION TERRENA DE 14/II GHz

Las bandas de frecuencia de 14 y II GHz son empleados para los sistemas de satélite INTELSAT V. Las estaciones terrenas que emplearan estas bandas de frecuencias deben de

~~5380~~
contar con nuevas facilidades de comunicaciones que incluyan una antena que satisfaga las especificaciones de las normas para las estaciones terrenas tipo C. Dado que la atenuación de la propagación en las bandas de 14 y 11 GHz debido a lluvia es alta, puede ser necesario proporcionar una antena adicional para la operación por diversidad de espacio en la estación terrena localizada en áreas que tengan una fuerte precipitación pluvial. En este caso se requieren de 10 a 30 Kms. para la separación entre la estación principal y la estación auxiliar. Las dos estaciones serán conectadas por un enlace de interconexión de diversidad.

Los métodos de diversidad se clasifican de acuerdo a la combinación de las antenas empleadas en un modo balanceado y otro desbalanceado. El primero consiste de dos antenas que tienen el mismo diámetro y el segundo se emplean antenas que tienen diferente diámetro. Se están llevando a cabo estudios en antenas que se puedan utilizar en las dos bandas de 6/4 GHz y 14/11 GHz. Para lograr esto se ha requerido emplear cornetas corrugadas y un diplexer el cual se usará comúnmente en ambas bandas de frecuencia. Debe hacerse un estudio en la exactitud de rastreo del satélite debido al pequeño ancho del haz empleado en esta banda de 14/11 GHz.

2.4 EJEMPLOS DE ESTACIONES TERRENAS ESTANDAR

Las características de funcionamiento de las estaciones terrenas estandar tipo A para los sistemas INTELSAT IV, IV A y V se muestran en la tabla (III).

TABLA III EJEMPLO DE CARACTERISTICAS DE FUNCIONAMIENTO DE ESTACIONES TERRENAS ESTANDAR INTELSAT

Característica	Estación terrena estandar A para INTELSAT IV y IV-A	Estación terrena estandar A para INTELSAT V.	
Razón de Ganancia a Temperatura de ruido (G/T)	Mayor de 41.7 dbk (a un ángulo de elevación de 5°)	Mayor de 42.6 dbk al ángulo de elevación de operación	
Sistema de antena	Tipo de antena	Cassegrain, alimentación mediante haz guiado con 4 reflectores	Cassegrain, alimentación mediante haz guiado con 4 reflectores
	Tipo de montaje	Con movimiento en azimuth y elevación	Con movimiento en azimuth y elevación
	Diámetro del reflector principal	29.6 m	34 m
	XPD (6/4 GHz)	63.4 db/60 db	65.6 db/61.9 db
	Peso	250 toneladas	430 toneladas
	Mecanismo para el movimiento	Dos motores de C.D.	Dos motores de C.D.
	Velocidad del viento maxima operable	33 m/s (pico)	35 m/s (pico)
	Sistema anticongelante	Calentador en la parte posterior del reflector principal (390 KVA)	Calentador en la parte posterior del reflector principal 585 KVA
Sistema transmisor	Programa de seguimiento (rastreo)	Procesamiento en tiempo real	Procesamiento en tiempo real
	Amplificador de alta potencia (HPA)	Amplificador de alta potencia a TOP de 8 KW	HPA a TOP de 10 KW (LHCP) HPA a TOP de 3 KW (RHCP)
	Número de portadoras de transmisión	16 (capacidad máxima)	24 (capacidad máxima)

	Sistema de transmisión entre el sitio de la antena y el edificio de control	Microondas con guía de onda	Microondas con guía de onda elíptica
Subsistema Receptor	Receptor de bajo ruido	Amps. paramétrico enfriados con helio y termoeléctricamente	Amps. paramétricos enfriados termoeléctricamente
	Número de portadoras de recepción	24 (capacidad máxima)	72 (capacidad máxima)
Subsistema GCE	Capacidad de la portadora de telefonía	24 - 1872 canales	12 - 1332 canales
	Conversión de frecuencia	Todos los tipos de frecuencia separación de portadora: 250 KHz	Todos los tipos de frecuencia separación de portadora: 250 KHz
	Demodulador { Telefonía Televisión	Extensión de umbral (hasta 252 canales y tipos convencionales tipo convencional	Tipo extensión de umbral (para todas las capacidades de portadora) tipo convencional
Subsistema Terminal	Equipo terminal multiplex telefónico (MUX)	Terminales variables MUX que corresponden a la composición de banda base de transmisión y recepción de destino múltiple.	
	Equipo terminal de televisión	Máxima capacidad de canal por portadora: 1872 canales Consola de operación de TV y convertor estándar para sistemas NTSC 525/60 y PAL 625/50 Equipo de TV asociada con audio	Máxima capacidad de canal por portadora: 1332 canales Consola de operación de TV y convertores estándar para sistemas NTSC 525/60, PAL 625/50 y SECAM 625/50 Equipo de TV asociada con audio
Subsistema de control de comunicaciones		Monitoreo centralizado y sistema de control	Sistema de control y de monitoreo central computarizado

	Sistema de transmisión entre el sitio de la antena y el edificio de control	Microondas con guía de onda	Microondas con guía de onda elíptica
Subsistema receptor	Receptor de bajo ruido.	Amps. paramétrico enfriados con helio y termoeléctricamente	Amps. paramétricos enfriados termoeléctricamente
	Número de portadoras de recepción	24 (capacidad máxima)	72 (capacidad máxima)
	Capacidad de la portadora de telefonía	24 - 1872 canales	12 - 1332 canales
Subsistema	Conversión de frecuencia	Todos los tipos de frecuencia separación de portadora: 250 KHz	Todos los tipos de frecuencia separación de portadora: 250 KHz
DE	Demodulador { Telefonía Televisión	Extensión de umbral (hasta 252 canales y tipos convencionales tipo convencional	Tipo extensión de umbral (para todas las capacidades de portadora) tipo convencional
	Equipo terminal multiplex telefónico (MUX)	Terminales variables MUX que corresponden a la composición de banda base de transmisión y recepción de destino múltiple.	
Subsistema terminal	Equipo terminal de televisión	Máxima capacidad de canal por portadora: 1872 canales Consola de operación de TV y conversor estandar para sistemas NTSC 525/60 y PAL 625/50 Equipo de TV asociada con audio	Máxima capacidad de canal por portadora: 1332 canales Consola de operación de TV y conversores estandar para sistemas NTSC 525/60, PAL 625/50 y SECAM 625/50 Equipo de TV asociada con audio
	Subsistema de control de comunicaciones	Monitoreo centralizado y sistema de control	Sistema de control y de monitoreo central computarizado

(3) REUSO DE FRECUENCIAS POR MEDIO DE POLARIZACION ORTOGONAL

453

En la serie de satélites INTELSAT V se utiliza el reuso de frecuencias por medio de la polarización ortogonal. Con el fin de tener acceso a dichos satélites, se requiere que la antena de la estación terrena tenga buenas características de polarización cruzada y, en algunos casos capacidad de compensación para la degradación de la discriminación de la polarización cruzada (XPD) debido a la lluvia. Lo primero puede lograrse empleando una combinación de antena CASSEGRAIN del tipo de alimentador con haz guiado con un sistema alimentador de alta eficiencia, mientras que lo último puede lograrse desarrollando una red de compensación de polarización cruzada.

3.1 ENSAMBLE ALIMENTADOR PARA POLARIZACION CRUZADA

Existen dos tipos de sistemas de alimentación con polarización ortogonal, uno es el tipo de banda ancha y el otro el tipo de banda angosta. El sistema de alimentación del tipo de banda angosta proporciona polarizadores independientes para las bandas de 6 y 4 GHz y generalmente se prefiere debido a su funcionamiento XPD superior. La fig. (4) muestra un diagrama a bloques del ensamble de la alimentación con polarización ortogonal. Con este ensamble de alimentación, la señal recibida de la antena se alimenta a los dos ensambles de unión de modo ortogonal (OMJ) (Ortho-mode Junction) donde la señal recibida en la banda de 4 GHz se separa de la señal transmitida a 6 GHz. Las señales LHCP y RHCP se convierten en señales de polarización lineal ortogonal en cada banda de frecuencia empleando un desviador de fase diferen-

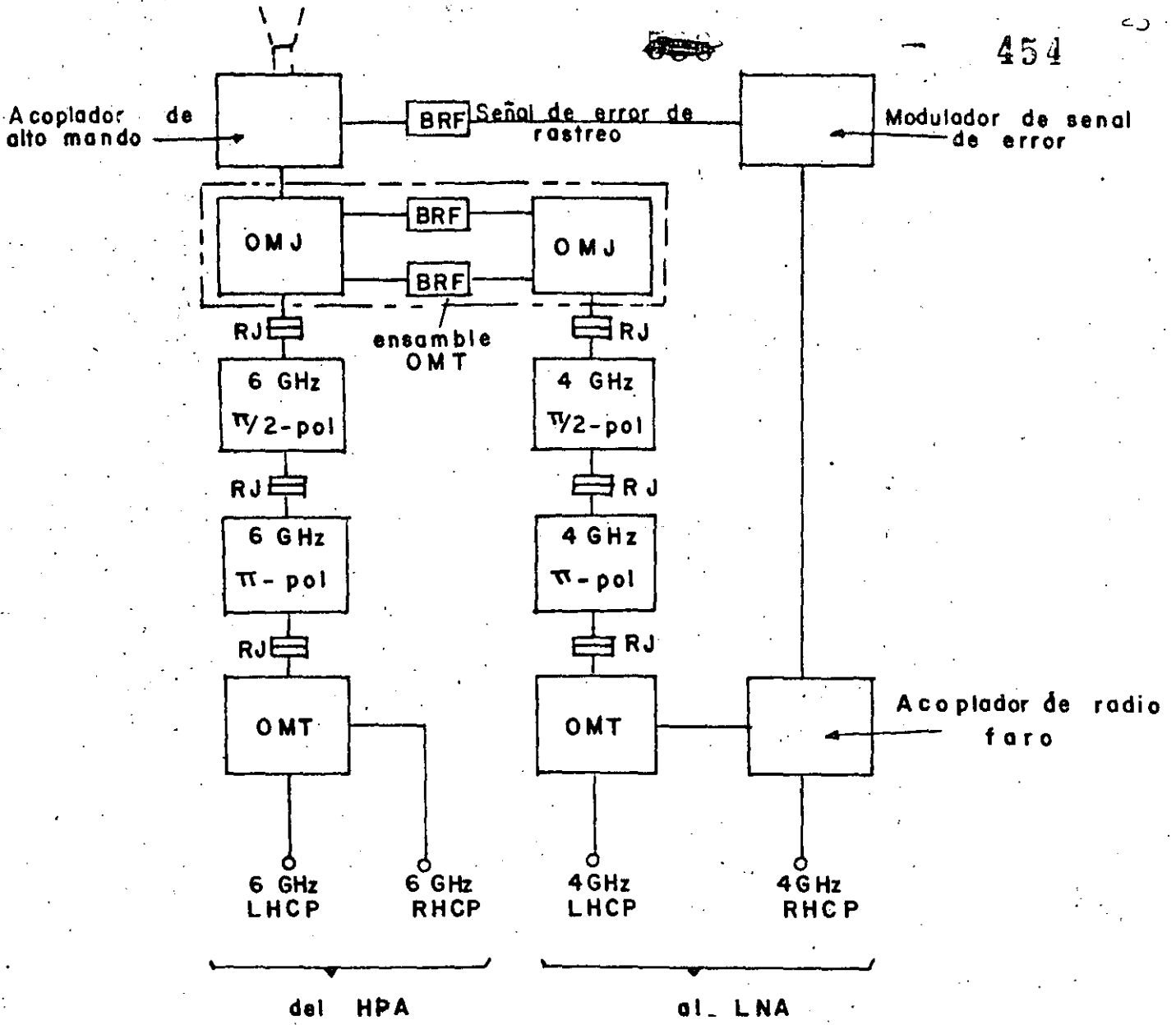


Fig. 4 Diagrama a bloques de un ensamble de alimentación para polarización ortogonal

- BRF: Filtro supresor de banda de transmisión
- RJ: Unión giratoria
- OMJ: Unión de modo ortogonal
- OMT: Transductor de modo ortogonal
- POI: Polarizador
- LHCP: Polarizador circular de mano izquierda
- RHCP: Polarizador circular de mano derecha

dor de fase diferencial de media onda (polarizador Π).

Las señales de alto modo para el rastreo de la antena se seleccionan mediante los acopladores de alto modo y se envían al modulador de señal de error para separar la señal - error de la señal de referencia. Entonces la señal modulada se combina con la señal de referencia a través del acoplador del radiofaro, y se envía al LNA. Las señales transmitidas - por los puertos LHCP y RHCP y generadas en el HPA con polarización lineal se combinan mediante el transductor de modo -- ortogonal (OMT) y convertidas a una señal con polarización -- circular ortogonal por el polarizador de $\Pi/2$ y alimentadas a la antena.

Las características de funcionamiento del ensamble de alimentación con polarización ortogonal se muestran en la tabla IV.

Tabla IV Características de funcionamiento medidas del ensamble de alimentación para polarización ortogonal.

Característica	Transmisión	Recepción
Ancho de banda	5.925 - 6.425 GHz	3.7 - 4.2 GHz
Polarización	LHCP	RHCP
V S W R	Menor de 1.15	Menor de 1.15
Raxón Axial	Menor de 0.14db	Menor de 0.33db
Pérdida de inserción	Menor de 0.20db	Menor de 0.24db
Aislamiento entre Puertos	Mayor de 26db	Mayor de 24db
Fuga de onda transmitida	—	Menor de -80db a la entrada - del LNA con BRF

3.2 RED COMPENSADORA DE DEFOLARIZACION

La degradación de la discriminación de polarización cruzada (XPD) en la trayectoria de propagación de la onda de radio resulta del desviador de fase diferencial (DPS) y el -- atenuador diferencial (DA) debido a la lluvia. El sistema -- requiere de un alto funcionamiento de la XPD que compense la degradación individual en el ascenso y en descenso.

1) Configuración

Hay dos tipos típicos de red de compensación XPD: -- el tipo A y el tipo B, los cuales se muestran en la fig. (5). El tipo A tiene una configuración tal que la red de compensación principal la cual compensa el DPS y la red compensadora auxiliar para D A se incluyen dentro del ensamble de alimentación de la antena. En este tipo, la inserción de la red de -- compensación, especialmente aquella para DA puede originar un incremento en la temperatura de ruido de aproximadamente 15°K y un incremento en la pérdida de alimentación en banda de -- transmisión de 0.15 a 1.5 db. A pesar de esta característica este tipo no requiere funcionamiento balanceado para HPA's -- como es el caso del tipo B. Por lo tanto, este tipo se consi dera prometedor para la compensación en el ascenso.

En el tipo B, solamente se incluye la red de compen sación DPS en el ensamble alimentador de la antena, y la red de compensación DA se inserta en la salida del LNA o a la -- entrada del HPA. En este tipo, el incremento de la temperatu ra de ruido del sistema receptor y la pérdida de inserción a la salida del HPA debido a la red de compensación, se estima

de $2^{\circ}K$ y 0.05 db respectivamente. Sin embargo, este tipo -- requiere un funcionamiento altamente balanceado entre los -- HPA's con respecto a la respuesta amplitud - frecuencia y la respuesta fase - frecuencia, la cual es algo difícil de lo -- lograr. Por lo tanto, el tipo B se le considera efectivo para la compensación XPD en el descenso.

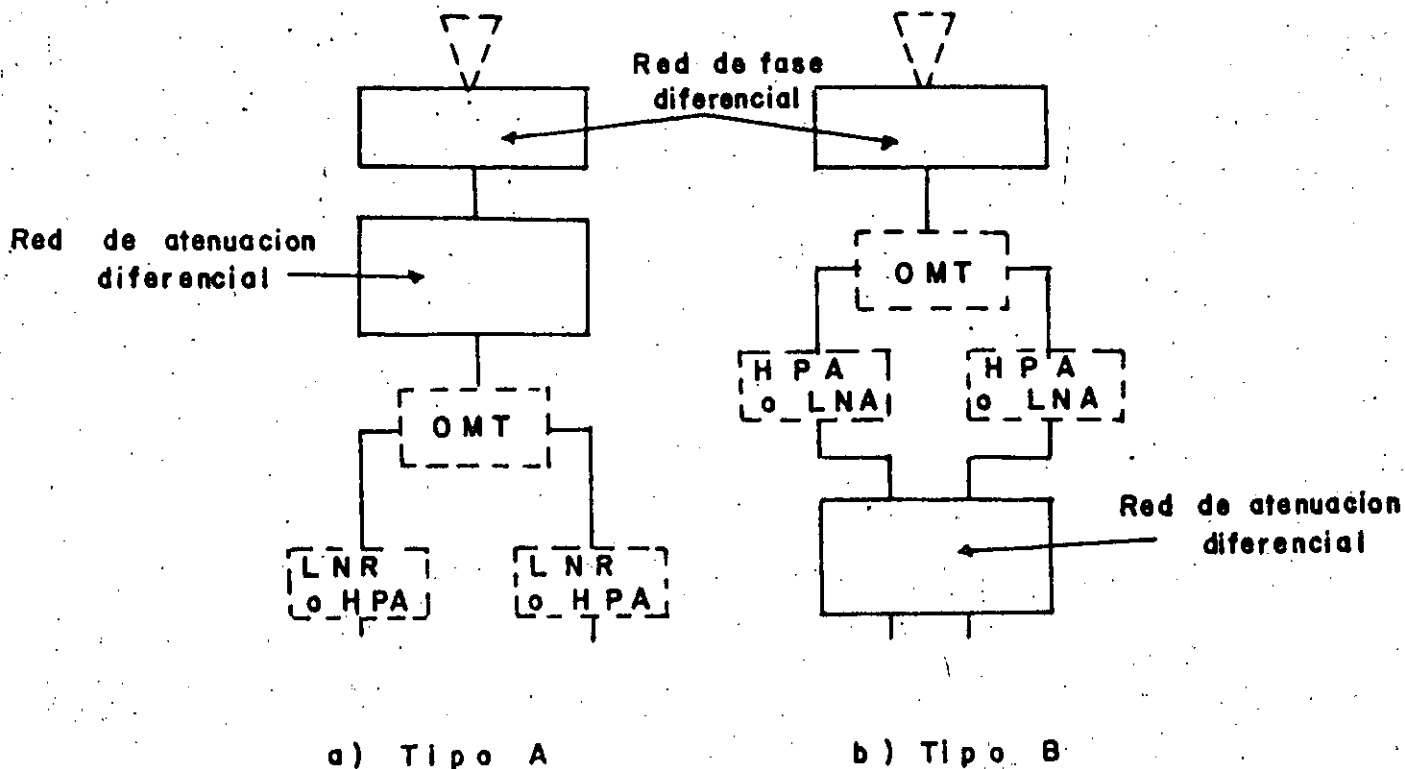


Fig. 5 Configuración de la red compensadora de despolarización

2) Método de Control

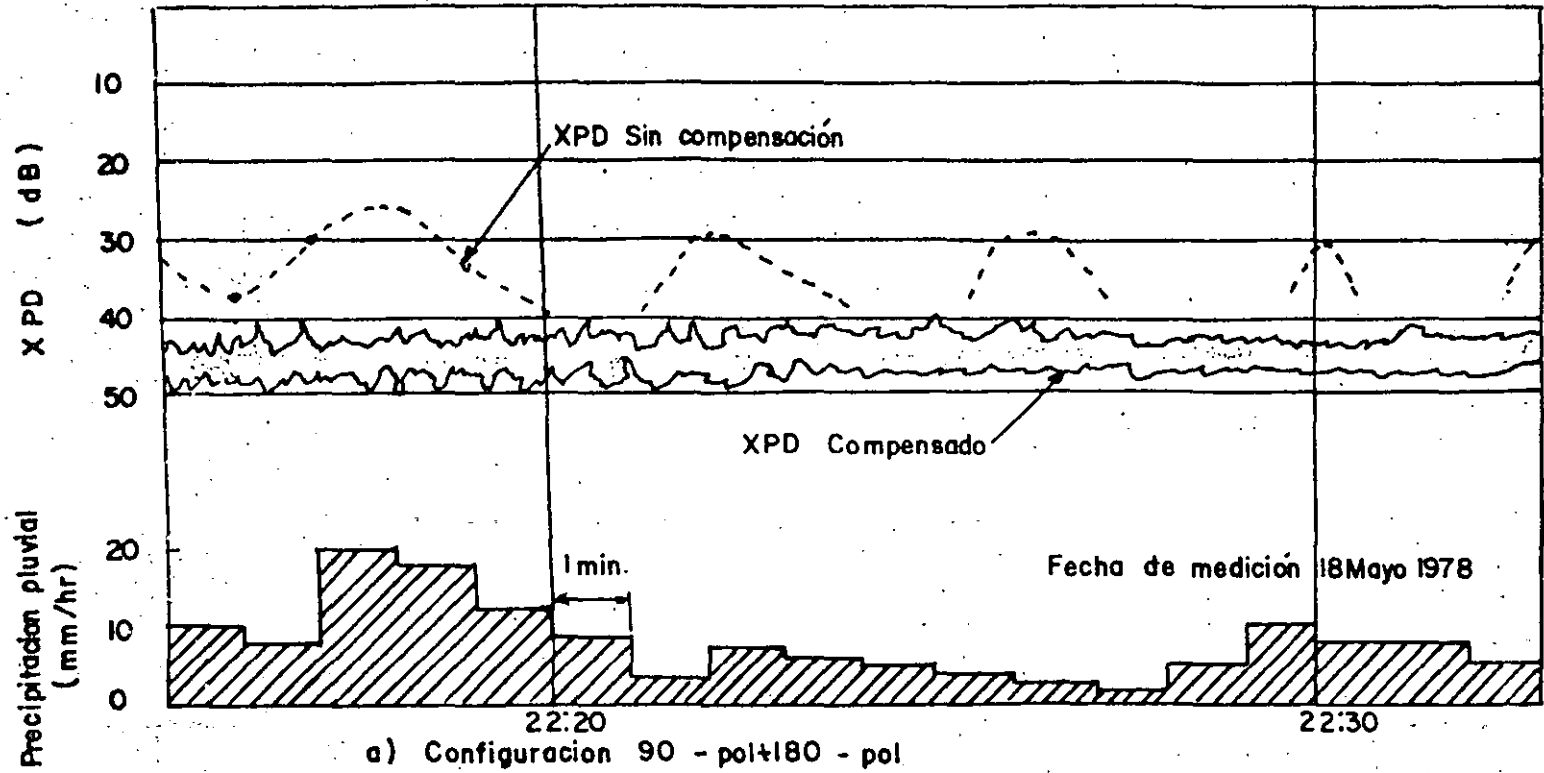
La red de compensación aplicada al descenso es controlada por la recepción de la señal piloto en la banda de 4 GHz radiada desde el satélite y de así detectando la diferencia de fase entre la componente copolarizada y la componente con polarización cruzada inducida en la trayectoria de propagación, así como la razón de amplitud entre estas dos componentes. A esto se le llama el método de control por piloto.

Se consideraran dos métodos de control de la red de compensación que se aplican al ascenso. Uno es el llamado método de control de correlación, en el cual el control es llevado a cabo estimando los valores de DPS y DA del ascenso a partir de la señal de control para el descenso se utiliza la correlación de DPS entre los dos enlaces. El otro es el conocido método de control por piloto en el cual la señal de control del ascenso se deduce de la señal piloto en la banda de 6 GHz la cual se transmite desde la estación terrena respectiva.

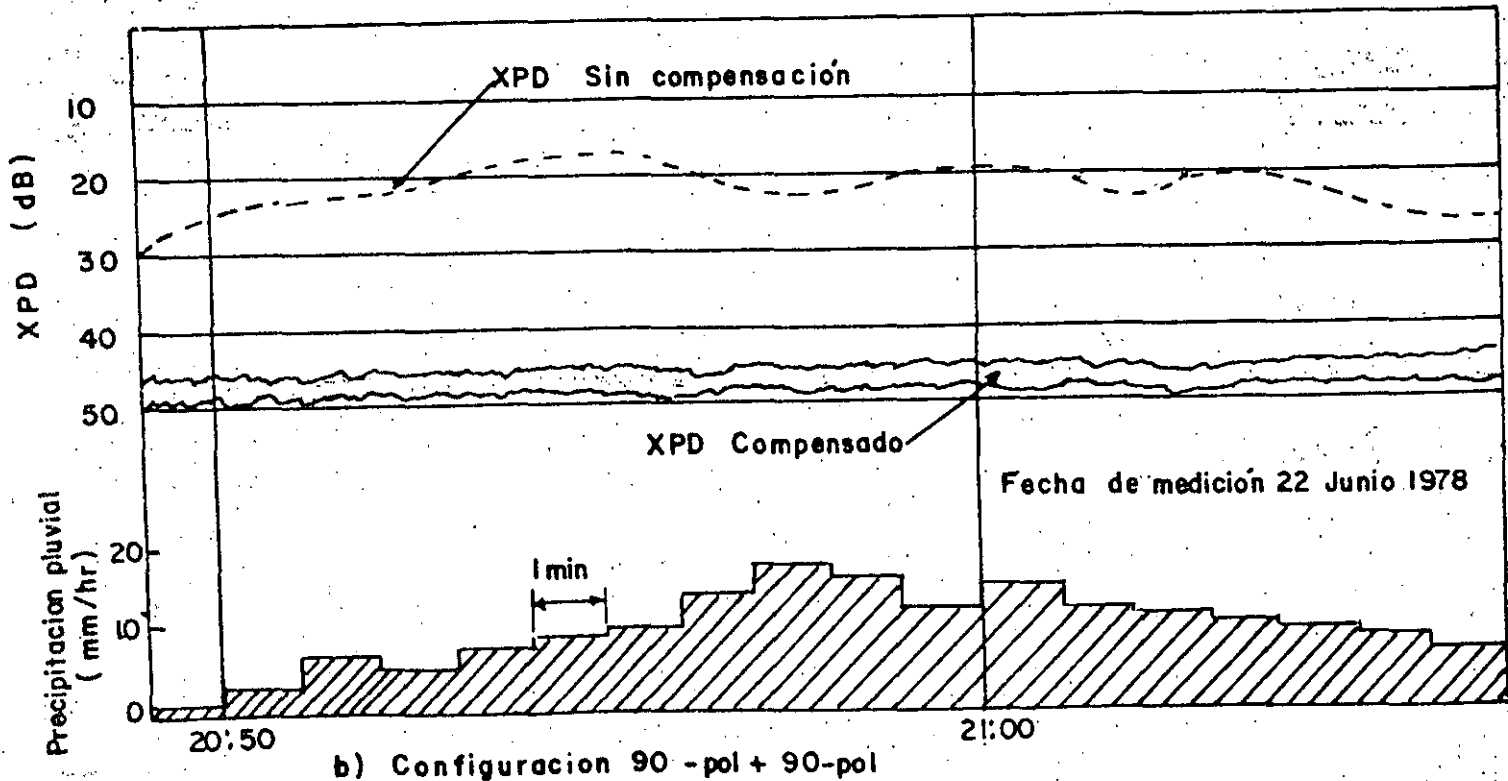
3) Funcionamiento de Compensación

Hay dos configuraciones típicas de la red de compensación, una viene siendo la combinación de un polarizador de $\pi/2$ y un polarizador de π , y la otra la combinación de dos polarizadores de $\pi/2$. La fig. (6) muestra ejemplos del mejoramiento de XPD alcanzado al emplear estas redes de compensación en una condición de lluvia. Se observa de estas figuras que cualquiera de estas redes es capaz de compensar

la XPD degradada de 20 db hasta aproximadamente 40 db.



a) Configuración 90 - pol + 180 - pol



b) Configuración 90 - pol + 90-pol

Fig. 6. Mejoramiento de XPD mediante redes compensadoras de depolarización

8.4 TECNICAS DE TRANSMISION DE ALTA POTENCIA

La escala del amplificador de alta potencia (HPA) en una estación terrena depende principalmente del número de portadoras por transmitir asignadas a la estación terrena -- considerada y la E.I.R.P requerida. A continuación se describirán las técnicas recientes de un HPA incluyendo los tubos de onda progresiva (TOP) de alta potencia de 8 a 12 KW empleados en grandes estaciones terrenas.

4.1 DEPRESION DEL COLECTOR EN TOP DE ALTA POTENCIA

Cuando se emplea un TOP como amplificador de alta potencia, es necesario considerar una reducción del consumo de potencia por el incremento de la eficiencia del TOP, y la simplificación del sistema de enfriado. Como uno de los medios para lograr este objetivo, se emplea el método de depresión del colector.

Este método reduce la energía cinética mediante la depresión del potencial del colector por abajo del voltaje de línea de retardo (cuerpo) y reduce consecuentemente la generación de calor mejorando la eficiencia del TOP. Sin embargo, con el colector de un tipo simple, la depresión del potencial del colector abajo del voltaje del cuerpo puede producir emisión secundaria de electrones y una elevación brusca en la corriente del cuerpo.

Como resultado se incrementa la pérdida de energía cinética del cuerpo. Por lo tanto, con el fin de asegurar -- una depresión del colector adecuada, es necesario diseñar la configuración del colector de tal forma que impide el flujo --

de regreso de la emisión secundaria de electrones al cuerpo.

La fig. (7) muestra la depresión del colector logra da protegiendo magnéticamente la porción bombardeada del colector. La apertura del colector es ligeramente mayor en su diámetro que el haz de electrones, dado que la eficiencia del TOP viene a ser mayor cuando el tamaño de la apertura del colector sea mas pequeña. Esto significa que puede obtenerse una depresión del colector de alto grado haciendo más pequeño el diámetro del haz de electrones y consecuentemente puede incrementarse la eficiencia del TOP. Con un TOP que tenga por ejemplo una potencia de salida máxima de 12 KW (LD-4052A), es posible incrementar la eficiencia total aproximadamente un 6% mediante la depresión del voltaje colector desde su nivel normal de 25 KV a 16 KV.

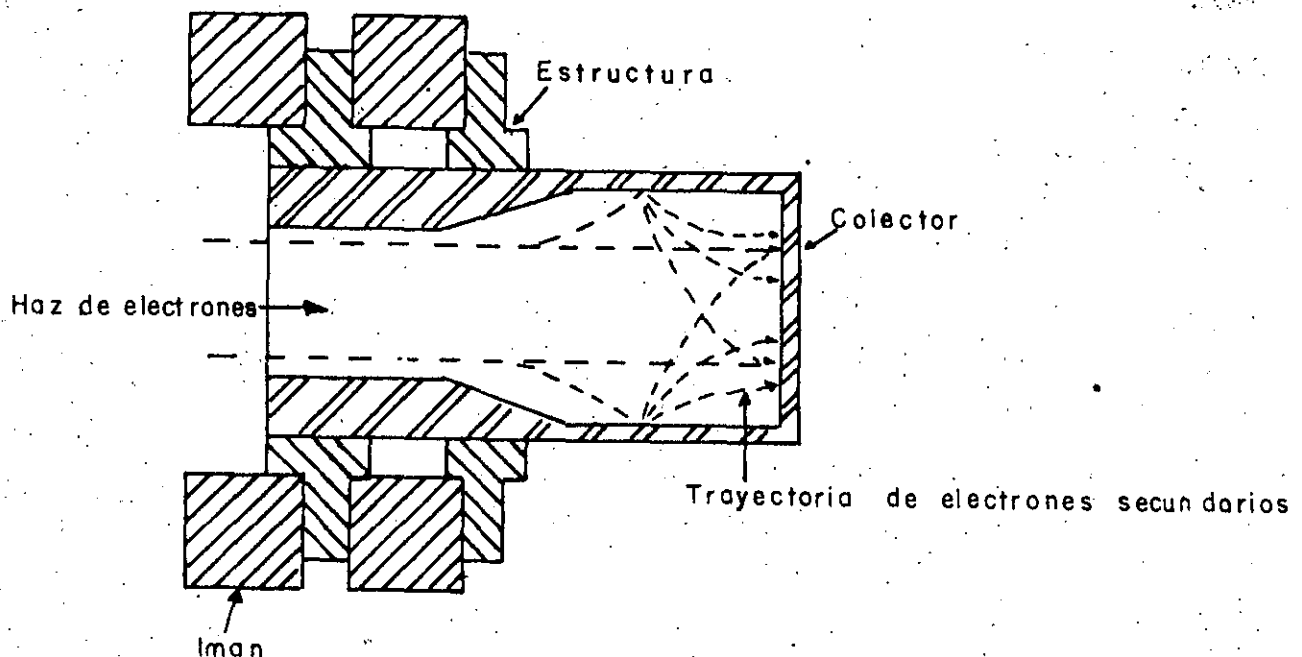


Fig. 7. Estructura del colector de TOP mejorado

4.3 COMPENSADOR DE DISTORSION POR INTERMUDULACION

La amplificación común de portadoras múltiples origina productos de intermodulación (IM) debido a la no linealidad del TOP. Hay dos tipos de no linealidad, la no linealidad de amplitud entrada-salida y la no linealidad amplitud-fase (conversión AM-PM) la cual es de importancia cuando la envolvente de la portadora que se transmite no es plana. Dado que esta distorsión IM viene a producir interferencia cuando cae en la banda de frecuencias de transmisión, INTELSAT ha establecido una estricta especificación para la emisión IM de las estaciones terrenas (ver tabla I). Por lo tanto es una práctica general para las estaciones terrenas que emplean el sistema de amplificación común mantener suficiente tolerancia en el punto de operación para evitar la distorsión IM al emplear TOP's de alta potencia con una potencia de saturación de 5 a 10 veces la potencia de la portadora requerida.

Dado que la potencia de distorsión IM se incrementa en proporción a la tercer potencia de los niveles de portadora, se requiere de TOP's de mayor potencia si la potencia de portadora es mayor de acuerdo al incremento de capacidad de transmisión. Por supuesto es difícil lograr dicha alta potencia del HPA desde un punto de vista económico y técnico. Por lo antes expuesto, se ha propuesto un método para reducir la distorsión IM compensando las características de linealidad de amplitud del TOP y de conversión AM - PM.

I) Método de Compensación

Como un medio para compensar la linealidad de ampli

~~339~~

tud y fase de una función de transferencia, se considera el método de retroalimentación negativa. Sin embargo, este método no es adecuado cuando no puede ignorarse el retardo debido a la velocidad viajera del electrón dentro del tubo como en el caso de un TOP de alta potencia. En lugar de lo anterior, se consideran los siguientes tres métodos; (i) el método de predistorsión, (ii) el método de alimentación directa y (iii) el método de modulación de hélice. De estos tres métodos, el método de alimentación directa no es adecuado como un método de compensación para TOP's de alta potencia, debido a que se requiere de un amplificador de potencia auxiliar que consiste de un TOP o de una clase similar el cual debe tener las mismas características que el TOP principal. El método de modulación de hélice es también inadecuado debido a que el control del -- circuito de alto voltaje del TOP hace la configuración del -- circuito complejo y la compensación se limita a la no linealidad de fase.

Por otro lado, el método de predistorsión es muy -- superior a los dos métodos anteriores, no obstante que requiere de un circuito de compensación el cual debe tener caracte-- rísticas exactamente opuestas a la no linealidad de la ampli-- tud y fase del sistema compensado, y esto da como resultado -- una restricción de la compensación efectiva.

2) Ejemplo de equipo de Compensación

Para un compensador de distorsión IM que emplea el método de predistorsión requiere de las siguientes condicio-- nes:

- (i) Una compensación sobre una gama amplia de frecuencias
- (ii) Una gama amplia de no linealidad para características opuestas
- (iii) Una configuración de circuito solamente en la gama de radiofrecuencia, y
- (iv) Simplicidad en la estructura

El equipo actual consiste de un generador de distorsiones no lineal, un ecualizador de amplitud y ecualizador de fase como se muestra en la fig. (8). El generador no lineal se muestra en la fig. (9).

La señal de entrada se divide en dos rutas, una viene siendo lineal y la otra no lineal, donde la señal no lineal es generada mediante un amplificador de microondas de baja potencia. Las dos señales se combinan diferencialmente y se obtiene la no linealidad de las características opuestas. Además se incorpora un ecualizador en este equipo para mejorar las características amplitud - frecuencia y fase - frecuencia debido a la transferencia de ganancia de los amplificadores TOP de alta potencia y Klystron dependiendo de la frecuencia.

En la fig. (10) se muestra un ejemplo de las mediciones de un compensador de distorsiones IM con tres portadoras, f_1 , f_2 y f_3 , los cuales fueron amplificadas en común por un amplificador de alta potencia TOP. Esta figura indica razones de potencia de portadora a potencia de distorsión IM (C/IM), con y sin compensador IM, mostrando las peores componentes tales como $(f_1 + f_2 - f_3)$, $(f_1 - f_2 + f_3)$ y -

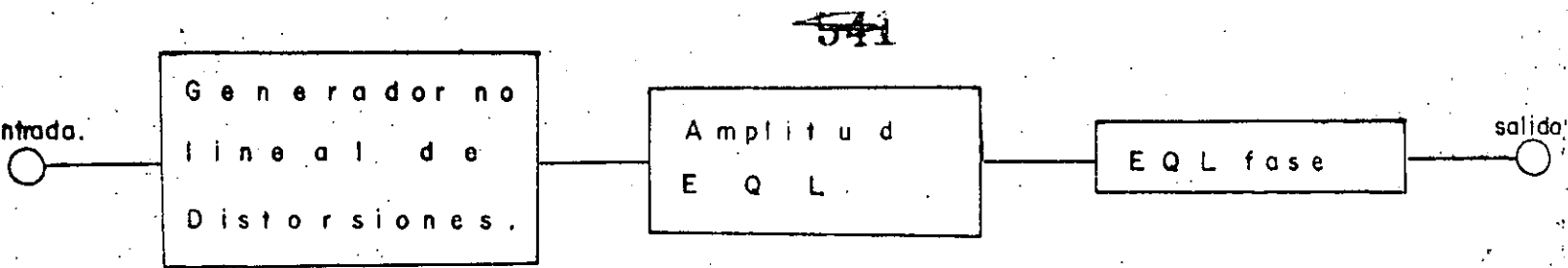


FIG. 8.- Diagrama a bloques de un compensador de IM para HPA mediante el método de predistorsión.

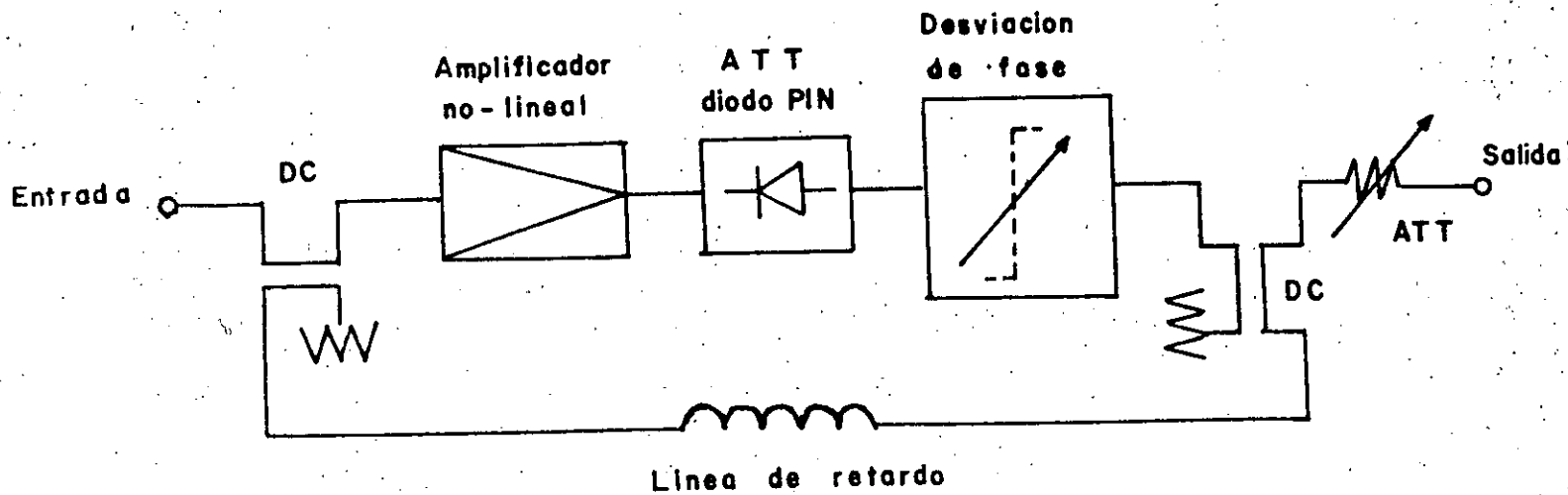


FIG. 9.- Configuración típica de un generador de distorsiones no lineal.

($-f_1 + f_2 + f_3$). Es claro de esta figura, que el compensador de distorsión IM proporciona mejoramientos de aproximadamente 10 db en una gama del punto de operación de salida del TOP de 6 a 10 db.

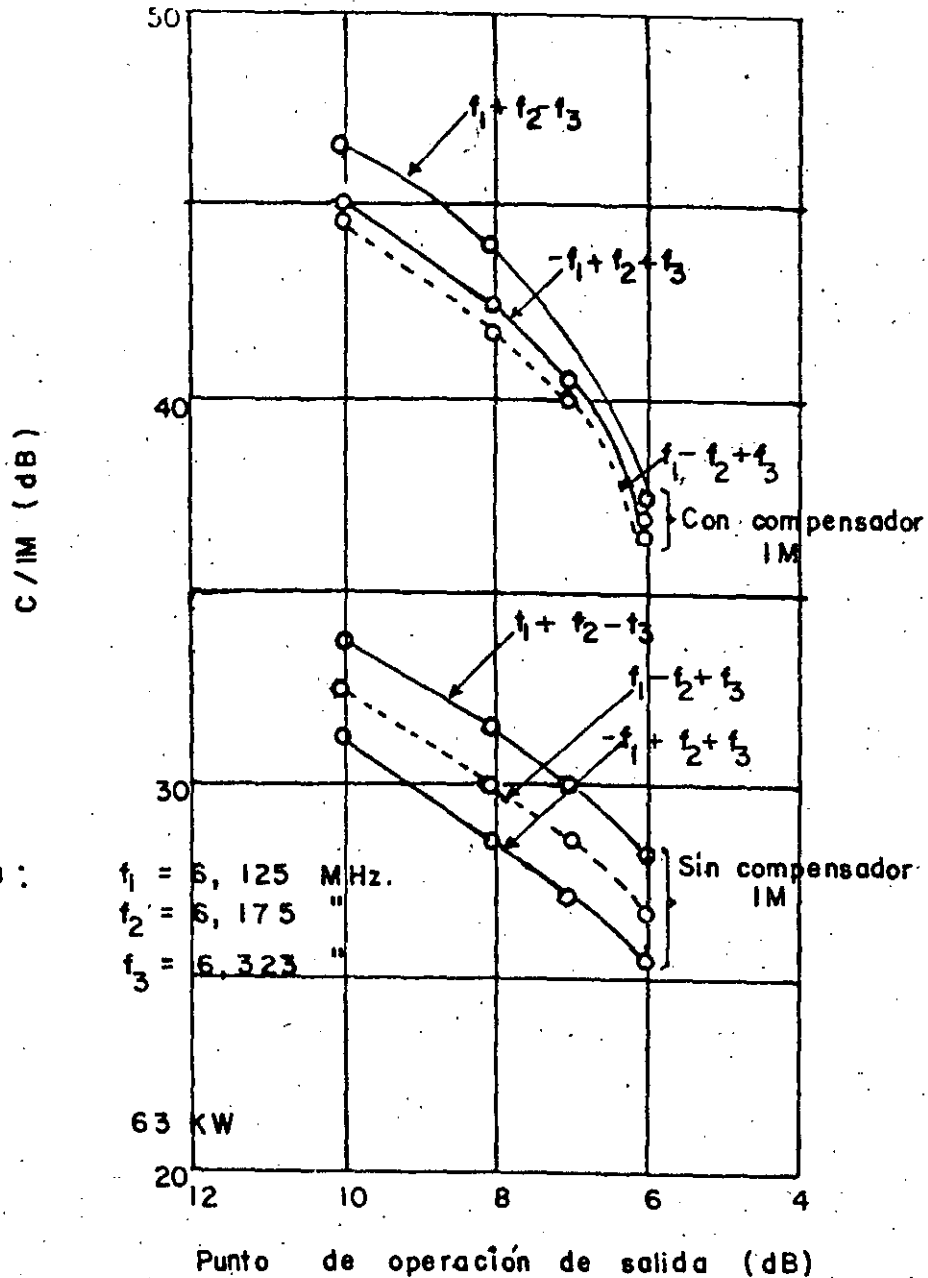


Fig. 10 Mejoramiento de productos de intermodulación por medio de compensación

5) TECNICAS DE RECEPCION CON BAJO RUIDO

Actualmente, están operando varias clases de amplificadores de bajo nivel de ruido (LNA's) en las estaciones terrenas. Las características típicas de estos amplificadores se muestran en la tabla (V). Entre ellos, los amplificadores paramétricos son superiores a otros debido a sus características de baja temperatura de ruido y su gran ancho de banda. Estos dispositivos son ampliamente empleados en las primeras etapas de un receptor en las estaciones terrenas. Existen también amplificadores a diodo tunnel y los más modernos que son a base de transistores FET's de bajo nivel de ruido.

5.1 AMPLIFICADOR PARAMETRICO

El circuito equivalente de un diodo varactor empleado en un amplificador paramétrico puede representarse mediante un circuito en serie de una capacitancia, la cual varía su valor de acuerdo a un voltaje externo de bombeo, y una resistencia r_a independiente del voltaje aplicado. La Q dinámica de un varactor (Q) esta dada por.

$$Q = \frac{\text{Variación de reactancia}}{4 \pi \gamma_d} \quad (1)$$

$$4 \pi \gamma_d$$

lo cual indica la figura de mérito del varactor. La temperatura de ruido T_e del amplificador paramétrico que emplea dicho varactor se expresa mediante la siguiente expresión:

$$T_e = \left(1 - \frac{1}{G}\right) T_d \frac{\tilde{Q}_s^2 \left(\frac{f_s}{f_i}\right)^2 + 1}{\tilde{Q}_s^2 \frac{f_s}{f_i} - 1} \quad (K) \quad (2)$$

donde

544

- G — Ganancia de amplificador
 Td — Temperatura ambiente del varactor
 \tilde{Q}_s — Q dinámica medida a f_s
 f_s — Frecuencia de la señal de entrada
 f_f — Frecuencia diferencia (LIBRE)

De la ecuación (2), pueden hacerse las siguientes observaciones, las cuales son efectivas en la reducción de la temperatura de ruido del amplificador paramétrico:

- (i) El empleo de un varactor con un alto Q dinámico
- (ii) La selección de una frecuencia libre apropiada
- (iii) El enfriamiento de la temperatura ambiente que rodea al varactor y los circuitos que forman el amplificador.

El amplificador paramétrico generalmente se mantiene a una temperatura constante mediante enfriamiento. Actualmente, los amplificadores paramétricos que se emplean ampliamente son aquellos que están enfriados por medio del gas helio y los que son enfriados termoeléctricamente por medio del efecto Peltier. En el primer caso, el amplificador paramétrico se coloca en un recipiente al vacío protegido de la temperatura externa y enfriado a aproximadamente 20°K mediante un refrigerador, mientras que en el segundo caso el amplificador es enfriado a aproximadamente -40°C . El último método tiene una ventaja que es el fácil mantenimiento debido a que no tiene mecanismos giratorios como en el caso de enfriamiento con helio. -- Recientemente se ha fabricado un amplificador que emplea el método de enfriamiento de efecto Peltier cuya temperatura de --

CARACTERISTICAS DE AMPLIFICADORES TIPICOS DE BAJO RUIDO

Característica	Amp. paramétrico enfriado con helio	Amp. paramétrico enfriado termo - electricamente	Amp. a diodo tunnel	Amp. a transistores de bajo ruido	Amp. Transistores de efecto de campo
Temperatura de ruido (figura de ruido)	10 - 20 K	35 K mínima	900-1,600 K (6 - 8 db)	900-3400 K (6 - 11 db)	70 K mínima
Ancho de banda	500 MHz	500 MHz	600 MHz	600 MHz	800 MHz
Ganancia	30 db	30 db	10 db	10 db	10 db
Potencia de salida a saturación	-10 a - 5 dbm	-10 a -5 dbm	-25 dbm	5 dbm	43 dbm
Sistema de enfriamiento	enfriamiento por medio de helio (gas)	enfriamiento termo eléctrico	—	—	—
Mantenimiento	moderado	fácil	fácil	fácil	fácil

ruido es inferior a los 40°K.

En la fig (11) se muestra un diagrama a bloques de un amplificador paramétrico enfriado termoelectricamente y en la tabla (VI) sus características de funcionamiento.

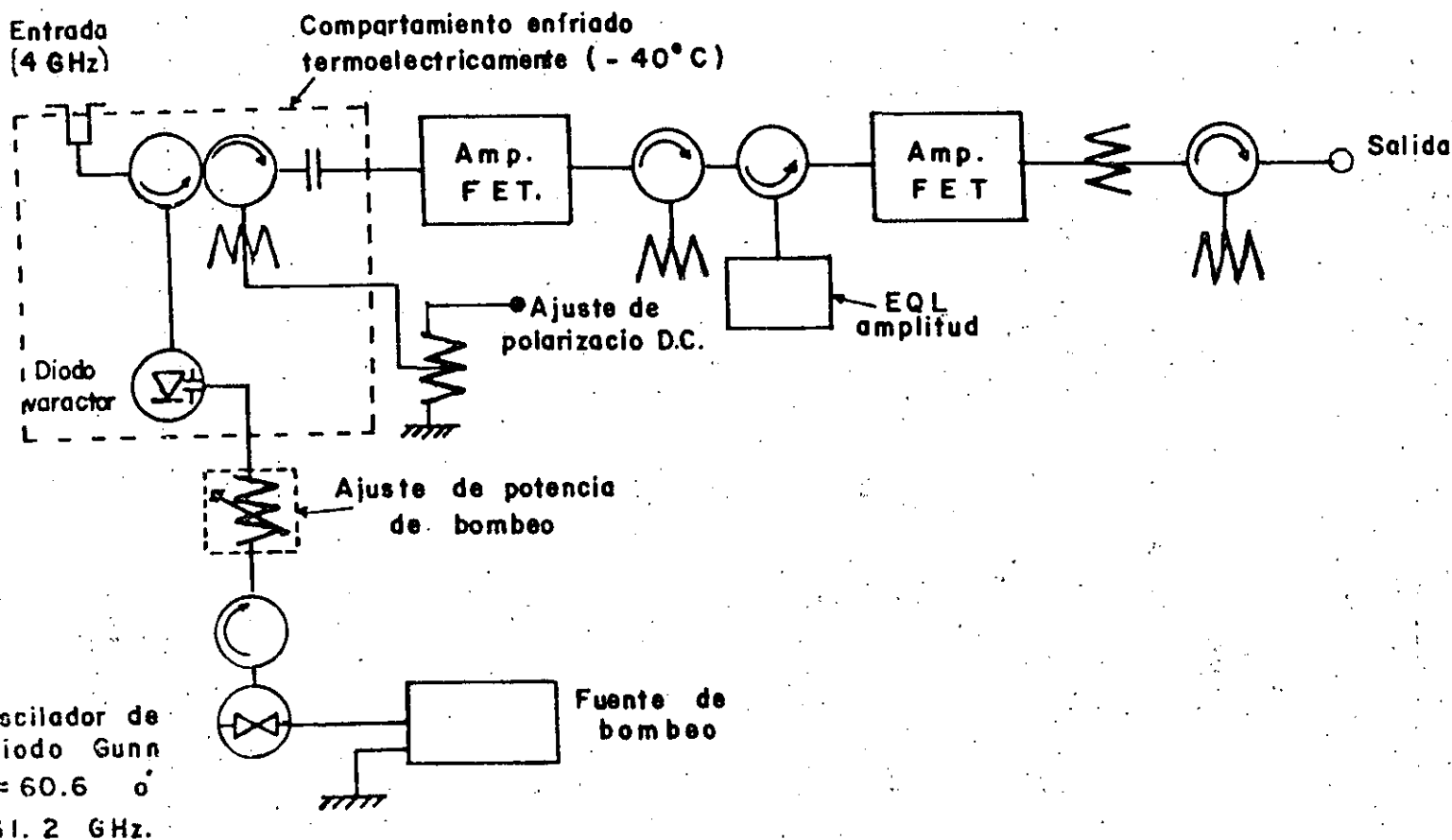


Fig. II Diagrama a bloques de un amplificador paramétrico enfriado termoelectricamente

Tabla (VI) Características de funcionamiento típicas de un amplificador paramétrico enfriado termoelectricamente.

Características	Funcionamiento
Ancho de banda	3,7 - 4.2 GHz
Ganancia	Superior a 60 db
Temperatura de ruido	Inferior a los 40K
Respuesta amplitud a frecuencia	Inferior a 1 db
Respuesta retardo de grupo a frecuencia	
Lineal	Dentro de ± 0.1 ns/MHz
Parabólico	Dentro de ± 0.03 ns/MHz ² ***
Rizo	Inferior a los 0.5 ns*
Respuesta fase a frecuencia	Inferior a los 50°/500 MHz*
Estabilidad de fase	Inferior a los 20°/mes
Estabilidad de nivel	Dentro ± 0.2 db/día Dentro de ± 0.5 db/semana

* Valor pico a pico

** Valor pico en cualquier ancho de banda de 40 MHz entre 3.7 y 4.2 GHz.

5.2 AMPLIFICADOR A TRANSISTORES DE EFECTO DE CAMPO

Un amplificador a transistores de efecto de campo consiste de FET's de barrera Schottky de GaAs desarrollados recientemente y muestran el mismo rendimiento eléctrico que los amplificadores paramétricos mencionados en la sección anterior. Este amplificador tiene unas características únicas que son su pequeño tamaño, poco peso y lo más atractivo que es su bajo costo. Puede observarse específicamente que el amplificador FET de GaAs proporciona características superiores a aquellas que ofrece el amplificador a transistores bipolar en lo que respecta a características de RF tales como bajo ruido, mayor gama de frecuencia y alta ganancia.

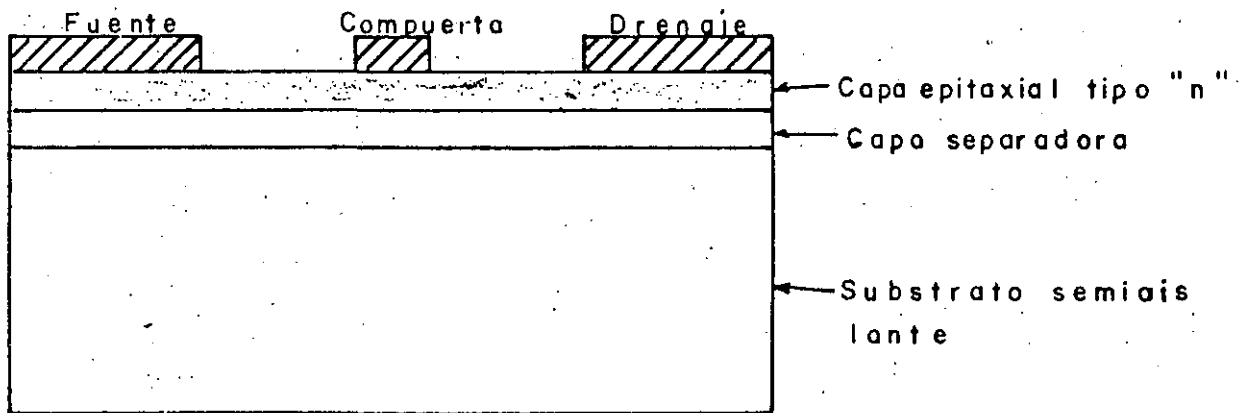


Fig. 12. Estructura básica del GaAs FET

El FET de GaAs el cual se muestra en la fig (12), está básicamente formado de una delgada capa epitaxial de GaAs tipo n de aproximadamente $0.3 \mu\text{m}$ de grueso depositada sobre un substrato de GaAs semi - aislado con una capa separadora -- entre ellos, un par de terminales ohmicas que son los electrodos de fuente y drenaje montados sobre la capa epitaxial, y -- una compuerta de barrera Schottky colocada entre estos dos electrodos.

Los factores principales de las buenas características de operación de los FET's de GaAs son;

- (i) El GaAs tiene una alta movilidad de los electrones y una alta velocidad de portadora saturada.
- (ii) La estructura del FET es relativamente simple y pueden formarse fácilmente patrones finos de aproximadamente $0.5 \mu\text{m}$.
- (iii) Comparado con el ruido de disparo de un transistor bipolar, el ruido generado en el FET de GaAs se incrementa en menor cantidad a altas frecuencias y
- (iv) La capacitancia parásita puede reducirse empleando un GaAs semiaislado como el substrato.

Actualmente se están empleando amplificadores de bajo nivel de ruido FET de GaAs para las bandas de 4, 12 y 20 GHz en comunicaciones. Se alcanza una temperatura de ruido inferior a los 90°K en la banda de 4 GHz empleando el sistema de enfriamiento termoeléctrico a -50°C .

6 TECNICAS DE TRANSMISION DE TELEVISION ~~550~~

Los desarrollos recientes en el campo de la técnica de transmisión de televisión son:

- (i) INTELSAT introdujo un nuevo sistema de transmisión de programas de televisión asociados con audio y
- (ii) un conversor de normas de televisión digitalizado de alta calidad para satisfacer el incremento de demanda para la transmisión de televisión, particularmente para la transmisión entre países que emplean sistemas diferentes.

6.1 EQUIPO DE PROGRAMA DE TELEVISION ASOCIADO CON AUDIO

Hay dos tipos de transmisión para la señal de un programa de audio de TV,

- (i) la transmisión por medio de una portadora FDM-FM que es asignada independiente de la portadora de video y
- (ii) la transmisión por medio de una portadora de video que es modulada de acuerdo con una señal de banda base multicanalizada que contiene la información de audio y video.

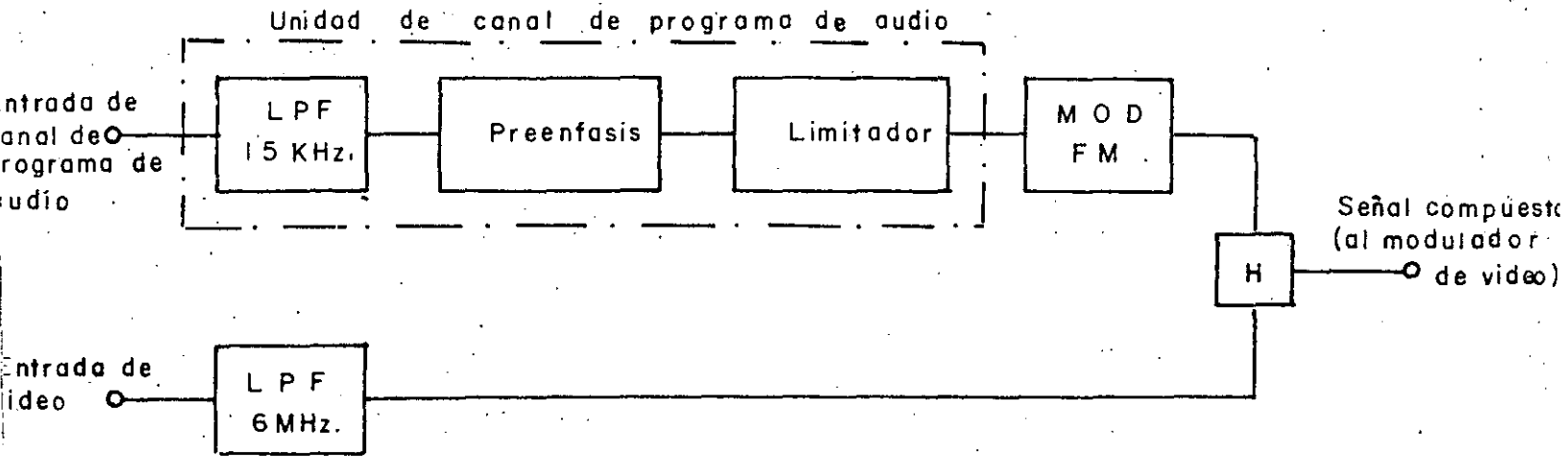
Con este sistema de transmisión la señal de audio de 0.05 a 10 KHz (o 6 KHz) es trasladada mediante un equipo de terminal para el sistema de portadora de radiodifusión en una señal de banda base correspondiente a 24 canales de telefonía multicanal.

La señal se transmite entonces en una portadora de 2.5 MHz después de ser procesada por el GCE.

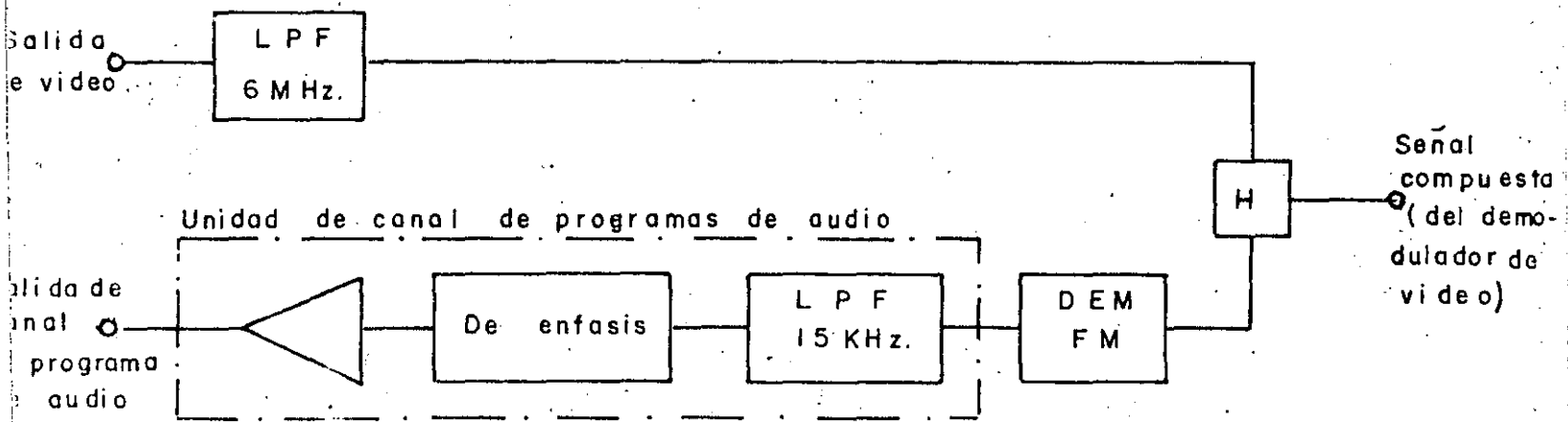
Uno de los últimos INTELSAT, incluye un sistema de transmisión de televisión asociada con audio empleando la técnica de subportadora de FM. La razón del porqué se emplea -- esta técnica, es debido a que las técnicas que conciernen a -- la subportadora de FM ya se han desarrollado, y el costo es -- comparativamente más bajo al modificar el equipo existente en las estaciones terrenas para este propósito.

En este sistema de transmisión de subportadora de -- FM, la subportadora de 6.6 MHz para el canal 1 y de 6.65 MHz para el canal 2 de TV, es modulada por la señal de audio con ancho de banda de 0.05 a 15 KHz. La señal modulada se combina con la señal de video para formar una señal de banda Base. Esta señal de B.B se transmite después de ser procesada por el GCE para la transmisión de TV.

En este sistema, como se ilustra en la fig. (13), la ruta de transmisión del equipo de TV asociado con audio se compone de una unidad de canal de programa de audio, un modulador (MOD), un circuito que combina la señal de video, etc. La trayectoria de recepción está compuesta de un circuito que separa la señal de video, un demodulador (DEM), SPCU, etc. -- Este equipo constituye una parte del subsistema de equipo -- terminal de la estación terrena como se ilustra en la fig. -- (13).



a) Trayectoria de transmisión



b) Trayectoria de recepción

Frecuencia subportadora para el canal I de TV: 6.60 MHz.
 " " " " " 2 de TV: 6.65 MHz.

Fig. 13. Diagrama a bloques de un equipo de audio de F.M. típico



6.2 CONVERSION DE NORMAS DE TELEVISION

Actualmente en el mundo se emplean varios sistemas de televisión. Las características típicas de las normas de TV aplicados en la transmisión Internacional de televisión se muestran en la tabla (7). En la transmisión Internacional es indispensable la conversión entre diferentes normas. INTELSAT recomienda que la sección receptora debe convertir la señal a un sistema de televisión nacional como una regla general.

1) CONVERSION DE NORMAS

La conversión de normas de televisión puede dividirse en la conversión del sistema de exploración y la del sistema de color. En la conversión del sistema de exploración, el número de líneas (525 o 625 líneas por cuadro o dos campos) y la frecuencia del campo (50 o 60 Hz) es convertido de tal manera que la señal de entrada es procesada básicamente suprimiendo o repitiendo las líneas y campos de acuerdo a la regla específica de conversión de señal. Además, las técnicas de interpolación de línea y campo son utilizadas con el fin de eliminar la discontinuidad geométrica y el movimiento o vibración de las imágenes. Para la conversión del sistema de color, la señal con el color deseado puede obtenerse mediante un proceso en que la señal de color codificada que llega será decodificada en tres señales de colores primarios (o señales diferencia de color) los cuales se codificarán otra vez para obtener la señal de color deseada de acuerdo con los sistemas de color específicos.

TABLA 7

CARACTERISTICAS TÍPICAS DE SEÑALES DE VIDEO Y DE SINCRONIA

		C A R A C T E R I S T I C A S				
Sistema de TV monocromática		M	B, G, H, I, D, K, K ₁ y L			
Sistema de TV cromática		M/NTSC	M/PAL	B,G y H/PAL	I/PAL	B,D,G,H,K,K ₁ y L/SECAM
No. de líneas por imagen (cuadro)		525		625		
Frecuencia de campo (valor nominal)		59.94 campos/s	60 campos/s	50 campos/s		
Periodo de línea		63.555 s	63.492 s	64 s		
Frecuencia de subportadora de crominancia		3,579,545 ± 10 Hz	3,575,611.49 ± 10 Hz	4,433,618.75 ± 5 Hz	4,433,618.75 ± 1 Hz	foe = 4,406,250 ± 2000 Hz fob = 4,425,000 ± 2000 Hz
Tipo de modulación de la suportadora de crominancia		Modulación en amplitud con portadora suprimida de dos subportadoras en cuadratura			Modulación en frecuencia	
Ancho de banda de video nominal		4.2 MHz		5MHz (B,G y H), 5.5MHz (I) y 6MHz (D,K,K ₁ y L)		
Abreviación del sistema	Señal de TV mono-cromática	525/60		625/50		
	Señal de TV cromática	525/60 NTSC	525/60 PAL	625/50 PAL		625/50 SECAM

147
554

TABLA 7

473

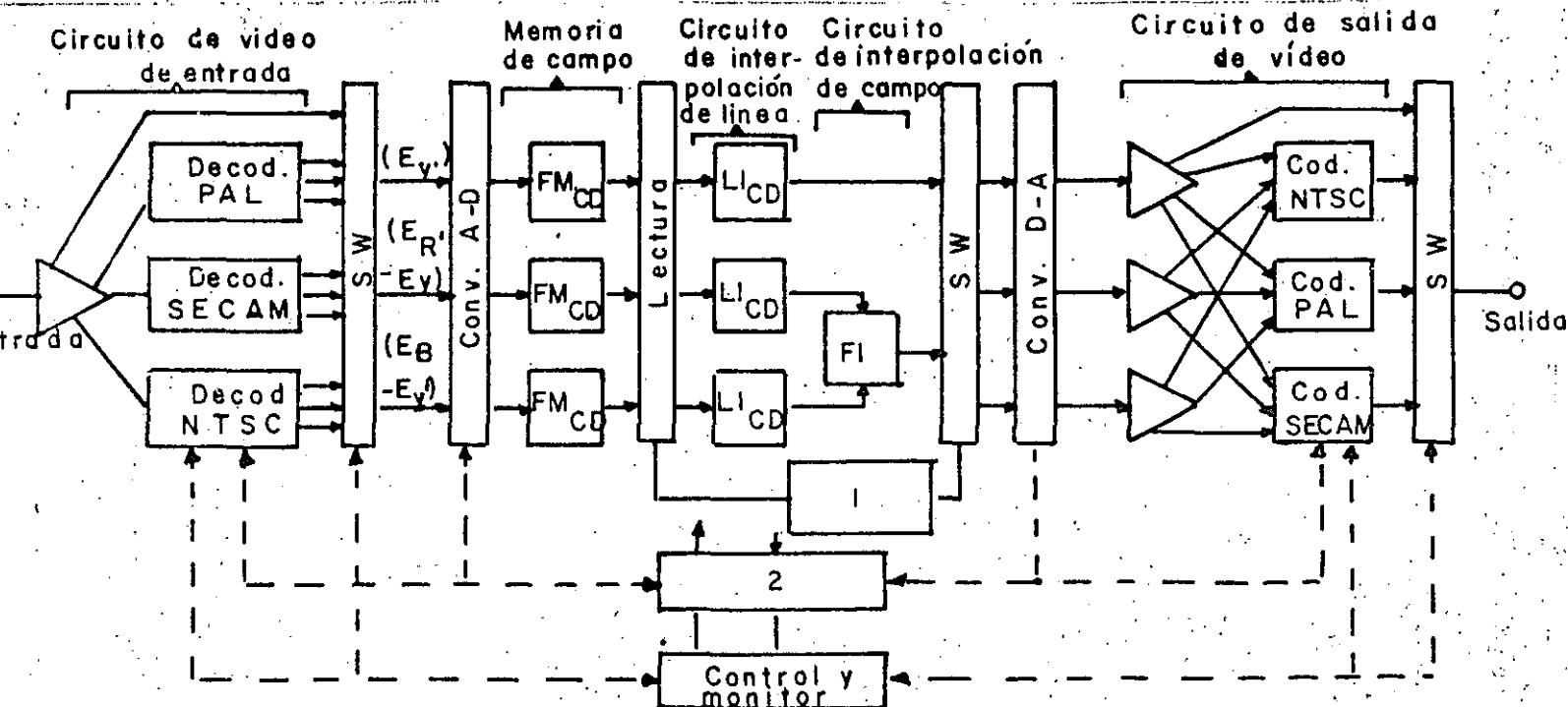
CARACTERISTICAS TIPICAS DE SEÑALES DE VIDEO Y DE SINCRONIA

		C A R A C T E R I S T I C A S				
Sistema de TV monocromática		M		B, G, H, I, D, K, K ₁ y L		
Sistema de TV cromática		M/NTSC	M/PAL	B,G y H/PAL	I/PAL	B,D,G,H,K,K ₁ y L/SECAM
No. de Líneas por imagen (cuadro)		525		625		
Frecuencia de campo (valor nominal)		59.94 campos/s	60 campos/s	50 campos/s		
Periodo de línea		63.555 s	63.492 s	64 s		
Frecuencia de subportadora de crominancia		3,579,545 ± 10 Hz	3,575,611.49 ± 10 Hz	4,433,618.75 ± 5 Hz	4,433,618.75 ± 1 Hz	f _{oe} = 4,406,250 ± 2000 f _{ob} = 4,425,000 ± 2000
Tipo de modulación de la portadora de crominancia		Modulación en amplitud con portadora suprimida de dos subportadoras en cuadratura				Modulación en frecuencia
Ancho de banda de video nominal		4.2 MHz		5MHz (B,G y H), 5.5MHz (I) y 6MHz (D,K, y L)		
Desviación del sistema	Señal de TV monocromática	525/60		625/50		
	Señal de TV cromática	525/60 NTSC	525/60 PAL	625/50 PAL		625/50 SECAM

El método de conversión de normas se clasifica en dos tipos, uno viene siendo el método de transferencia de imagen mediante el procesamiento óptico y el otro el método de conversión directa o método de conversión electrónico. El método de conversión directo se clasifica en el método analógico que emplea la memoria con línea de retardo como medio de almacenamiento y el método digital que emplea la memoria de IC. Recientemente se han popularizado los conversores de normas de TV digitalizados, debido a sus excelentes características eléctricas y su bajo precio.

2 EJEMPLO DE UN CONVERTOR DE NORMAS DE TV

La fig. (14) muestra un diagrama a bloques de un conversor digitalizado.



Amplificador de distribución de video

1. Detector de imagen en movimiento
2. Unidad de procesamiento temporal

Fig. 14 Diagrama a bloques de un conversor de

El proceso de conversión de este equipo es el ----
siguiente:

La señal compuesta de entrada se decodifica en la --
señal de luminancia (E_y') y las señales diferencia de color --
($E_R - E_y'$) y ($E_B - E_y'$) mediante el decodificador que corres-
ponde a las normas de la señal de entrada. En los sistemas --
NTSC y PAL, la separación de la señal de luminancia y las --
señales de color de la señal de video compuesta se lleva a --
cabo mediante un filtro tipo "peine" de tal manera que no se
degrade la resolución. Entonces la señal de salida del deco-
dificador se digitaliza mediante el conversor A-D. Los pará-
metros para la codificación de la señal se determinan tomando
en cuenta la reducción del ruido de cuantización y el ruido -
de sobrecarga.

Cada secuencia de señal imprime en una memoria de
IC la cual tiene una capacidad para tres campos. De esta --
memoria, se leen las señales de cada uno de los tres campos --
consecutivos línea por línea en sincronía con las señales de
sincronía de la norma del sistema de salida. Las señales que
se leen simultáneamente son aquellas señales de los tres cam-
pos que corresponden a la misma posición en la imagen. Hasta
este momento, las conversiones de línea y campo se desarro ---
llan suprimiendo o repitiendo líneas en los campos. Por ejem
plo, en el proceso de conversión del sistema 625/50 al siste-
ma 525/60, se suprime una línea cada 6 líneas y se repite un
campo cada 5 campos.

Como se mencionó anteriormente, las señales que han
sido leídas se envían al circuito de interpolación de línea -

(L_1 (1) - L_1 (3)). Cuando la señal de entrada es una imagen en movimiento, la interpolación de línea intracampo por L_1 (1) y L_1 (2) se desarrolla por la razón de la necesidad de compensar la distorsión geométrica debido a la diferencia en tiempo entre los dos campos secuenciales los cuales forman un cuadro en la exploración entrelazada. Cuando la señal de entrada es una imagen fija, se lleva a cabo la interpolación intra - cuadro por L_1 (3) debido a que la posición en la imagen no cambia con el tiempo. En el caso de imágenes en movimiento, además de lo anterior, la interpolación del campo se lleva a cabo a través del circuito de interpolación de campo (F_1) después de la interpolación de línea. La señal de entrada de una imagen en movimiento y la de una imagen fija se distinguen debido a la comparación entre la información de imagen de un cuadro de la señal de entrada y la del cuadro precedente. Para complementar la interpolación de línea y campo, se emplean los valores medios ponderados (pesados) entre líneas o campos.

Cuando la señal es convertida a su sistema de exploración, ésta se transforma en la señal analógica mediante el conversor D-A y entonces se codifica en una señal compuesta de color con las normas deseadas.

La tabla 8 muestra un ejemplo de parámetros y características de un conversor de normas de TV digitalizado. Es evidente de esta tabla que debido al mejoramiento en las técnicas de interpolación se obtenga una mejor calidad de imagen que la lograda por medio de los sistemas convencionales.

TABLA 8

EJEMPLO DE PARAMETROS Y CARACTERISTICAS DE UN CONVERSOR DE NORMAS DE TELEVISION

Característica	Funcionamiento
Parametros (1) Codificación Luminancia Crominancia	12 MHz/8 bits 3 MHz/8 bits
(2) Elemento de memoria	chip de 16 Kbit RAM-MOS
(3) Capacidad de memoria	7.1 Mbit
(4) Interpolación imagen fija	Interpolación de línea intra-cuadro, paso mínimo de factor de ponderación: 1/8
Imagen en movimiento	Interpolación de línea intra-campo, paso mínimo de factor de ponderación: 1/8
Interpolación de campo	Paso mínimo de factor de ponderación: 1/8
Modos de conversión	625/50 monocromático — 525/60 monocromático 625/50 PAL 525/60 NTSC 625/50 SECAM 525/60 NTSC 525/60 monocromático 625/50 monocromático 525/60 NTSC 625/50 PAL 525/60 NTSC 625/50 SECAM

<p>Características eléctricas</p> <p>(1) S/N</p> <p>Ruido aleatorio</p> <p>Ruido periódico</p> <p>Ruido impulsivo</p>	<p>Superior a 50 dB_{b-w/rms}</p> <p>Superior a 50 dB_{b-w/p-p} (50 Hz - 1 MHz)</p> <p>Superior a 30 dB_{b-w/p-p} (≥ 1 MHz)</p>
<p>(2) Distorsión lineal</p> <p>Tiempo de campo</p> <p>Tiempo de línea</p> <p>Tiempo corto</p>	<p>Dentro de $\pm 1\%$</p> <p>Dentro de $\pm 3\%$</p> <p>$K \leq 2$ (2T pulso seno cuadrado)</p>
<p>(3) Distorsión no lineal</p> <p>Saturación de color</p> <p>Error de fase</p>	<p>Dentro de $\pm 3\%$</p> <p>Dentro de $\pm 3\%$</p>
<p>(4) S/N de entrada requerida para una conversión estable</p>	<p>25 dB_{p-p/rms} (no ponderada), mínima</p>
<p>(5) Resolución</p> <p>Vertical</p> <p>Horizontal</p>	<p>Superior a 330 líneas</p> <p>Superior a 330 líneas para NTSC 525/60 y PAL 625/50</p> <p>Superior a 280 líneas para SECAM 625/50</p>

7 - ESTACIONES TERRENAS CON PEQUEÑAS ANTENAS

Como se ha discutido hasta aqui, las estaciones terrenas de gran capacidad, y con antenas parabólicas de -- aproximadamente 30 mts de diámetro permiten el manejo de -- 1200 canales de voz por cada canal del satélite y transmitir o recibir simultaneamente imágenes de TV de banda ancha de - alta calidad.

Existen pequeñas estaciones terminales de satélite que proporcionan una variedad de servicios de baja capacidad a sus usuarios, tales como:

Transmisión y Recepción de TV y Telefonía

Una pequeña terminal puede transmitir y, recibir simultáneamente señales de TV y un número pequeño de canales de voz.

Transmitir y Recibir TV

Estas estaciones pueden transmitir y recibir únicamente un solo canal de TV.

Recepción de TV

Estas pequeñas estaciones pueden recibir únicamente una señal de TV. Este tipo de estación es probablemente -- una de las más importantes debido a la gran aplicación que últimamente se les está dando.

Recepción de TV y Transmisión y Recepción de Telefonía

Este tipo de terminal proporciona comunicación telefónica, además de la recepción de un canal de TV.

Recepción y Transmisión de Telefonía Unicamente

Este tipo de estación proporciona las facilidades de comunicación empleando terminales con pequeñas antenas (del orden de 3 mts. de diámetro) la cual se puede construir a un bajo costo.

Los sistemas de comunicaciones que emplean antenas del orden de 10 y 30 metros de diámetro pueden manejar varios supergrupos de canales de voz (20 supergrupos o 1200 canales) y su frecuencia de operación en la mayor parte de los sistemas interfiere con los sistemas de comunicaciones FDM - FM de superficie.

Este tipo de estaciones terrenas (10 y 30 mts.) de alta capacidad cumplen, o deben cumplir con las normas recomendadas por el CCIR para sistemas de distribución local con el propósito de retransmitir los mensajes telefónicos o de TV recibidos a las redes telefónicas regionales o sistemas de radiodifusión comercial. En contraste, los sistemas que emplean pequeñas antenas (3-7 mts.) generalmente se conectan directamente al usuario y los requisitos para la calidad de la voz y de la imagen de TV pueden ser menos estrictos.

Las estaciones terrenas con pequeñas antenas requieren de una figura de mérito de 14 a 20 dB. Dichas terminales pueden recibir y presentar una imagen de TV de mediana calidad, o pueden manejar un pequeño número de canales de voz (12 canales). Se les puede emplear en regiones donde el requisito de comunicaciones es pequeño y también se puede manejar una variedad de información como son; televisión educativa, teleconferencias, telefonía, noticias y comunicaciones comerciales e industriales, etc. En cada uno de estos casos, los requisitos de capacidad mínima da como resultado el bajo costo de estas pequeñas estaciones que se desarrollan para que cumplan con estas necesidades.

Este tipo de estaciones terminales tienen un gran futuro, ya que en algunos países como el nuestro se está instalando un gran número de estaciones para llevar TV educativa y cuando menos un canal de voz a regiones remotas en las cuales las comunicaciones por otro medio es actualmente imposible. La utilización de un gran número de estas estaciones terrenas y debido al avance tecnológico en los dispositivos semiconductores de bajo ruido y no enfriados, está dando como resultado que el costo de cada terminal sea cada día menor.

El empleo de estaciones terrenas pequeñas ha sido posible gracias al desarrollo y puesta en órbita de los satélites de comunicaciones denominados domésticos, que fueron primeramente experimentados por los Canadienses con la serie ANIK y los Norteamericanos con los WESTAR.

Este tipo de satélites pueden colocar haces puntuales que provienen de sus antenas en un país seleccionado o una región de interés en la cual se requiere comunicaciones. Con un incremento de aproximadamente 8 dB. en la potencia de la señal recibida desde un satélite ANIK o WESTAR, comparada a la del haz de digamos el INTELSAT IV, se puede utilizar una antena de aproximadamente 10 mts. de diámetro con un preamplificador no enfriado y relativamente no tan complicado que pueda manejar el ancho de banda de la información de un transponder de 36 MHz.

Las terminales terrenas con pequeñas antenas utilizan en general el servicio de un solo canal por portadora (SCPC) el cual hace más eficiente el empleo del canal de cada satélite de comunicaciones doméstico y el cual manejará hasta 12 canales de voz ya sea con preasignación o con asignación de demanda.

En la fig. (15) y la tabla (9) se muestran respectivamente un diagrama a bloques de una estación terminal pequeña y la capacidad de la misma.

Como puede observarse en el diagrama, esta estación utiliza un reflector de 4.5 mts. para un sistema de un solo canal por portadora (SCPC). En este sistema se emplea un amplificador de potencia de 400 watts para alimentar a la antena en el ascenso; mientras que en la rama receptora se emplea un amplificador a transistores como el amplificador de bajo nivel de ruido (LNA). Este sistema en particular también incluye un demodulador separado de TV cromática, un monitor de TV y modems de voz SCPC - FM.

Antena parabólica con polarización lineal en banda "C"

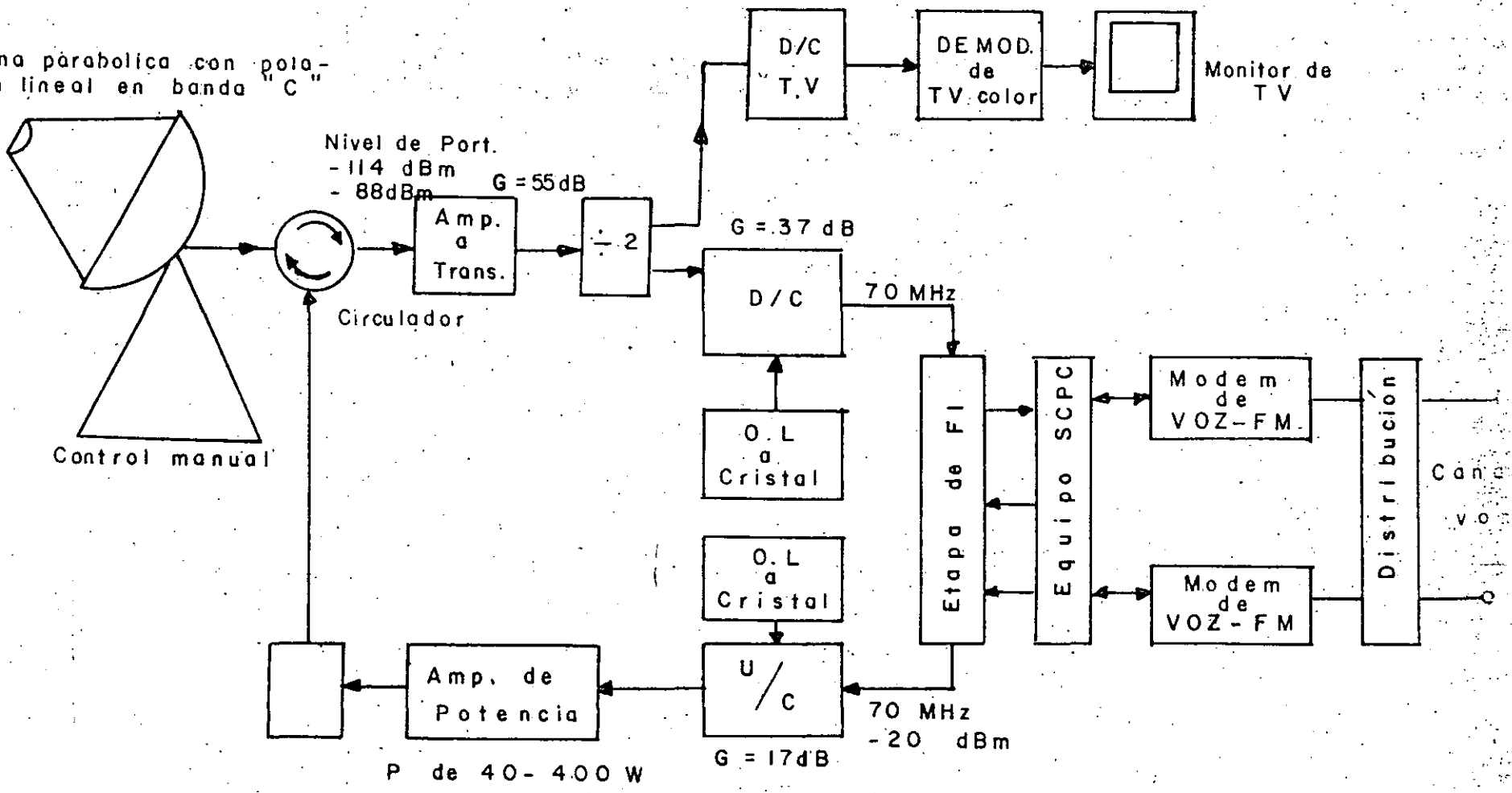


Fig. 15. Diagrama a bloques de una estación terrena de baja capacidad

CAPACIDAD DEL SISTEMA

CAPACIDAD DE LA PORTADORA TERMINAL								CARACTERISTICAS ESPERADAS EN LA RECEPCION DE TV					
Tipo de satélite	G/T Terminal	Voz FM de banda angosta			Datos FSK 2400 b/s cod. 3/4			TV Blanco y Negro			TV Cromatica		
		AP 10W	AP 100W	AP 400W	AP 10W	AP 100W	AP 400W	S/N	Grado	Calidad	S/N (C) pon.	Grado Taso	Calida
SK	13.2 dB/K con T A	1 portadoras	2 portadoras	8 portadoras	1 portadoras	10 portadoras	40 portadoras	43.8	3 (d)	aceptable equivalente a la clase B de la FCC (Radiodifusión áreas rurales D)	40.1	2	"Fina" para el 50% de los televidentes
AN	20 dB/K con preamp. no enfriado	1 portadoras	8 portadoras	32 portadoras	6 portadoras	85 portadoras	280 portadoras	50.5	2	Fina, equivalente a la clase A de la FCC (Radiodifusión urbana)	46.9	1	Fina para el 98% de los televidentes o excelente para el 50%.
TELESAT IV (Global)	13.2 dB/K con T A	(a)	(a)	(a)	(a)	(a)	1 portadora						
	20 dB/K con reamp no enfriado	(a)	(a)	(a)	(b) o portadora	1 portadora	4 portadoras						

Antena parabólica con polarización lineal en banda C

564

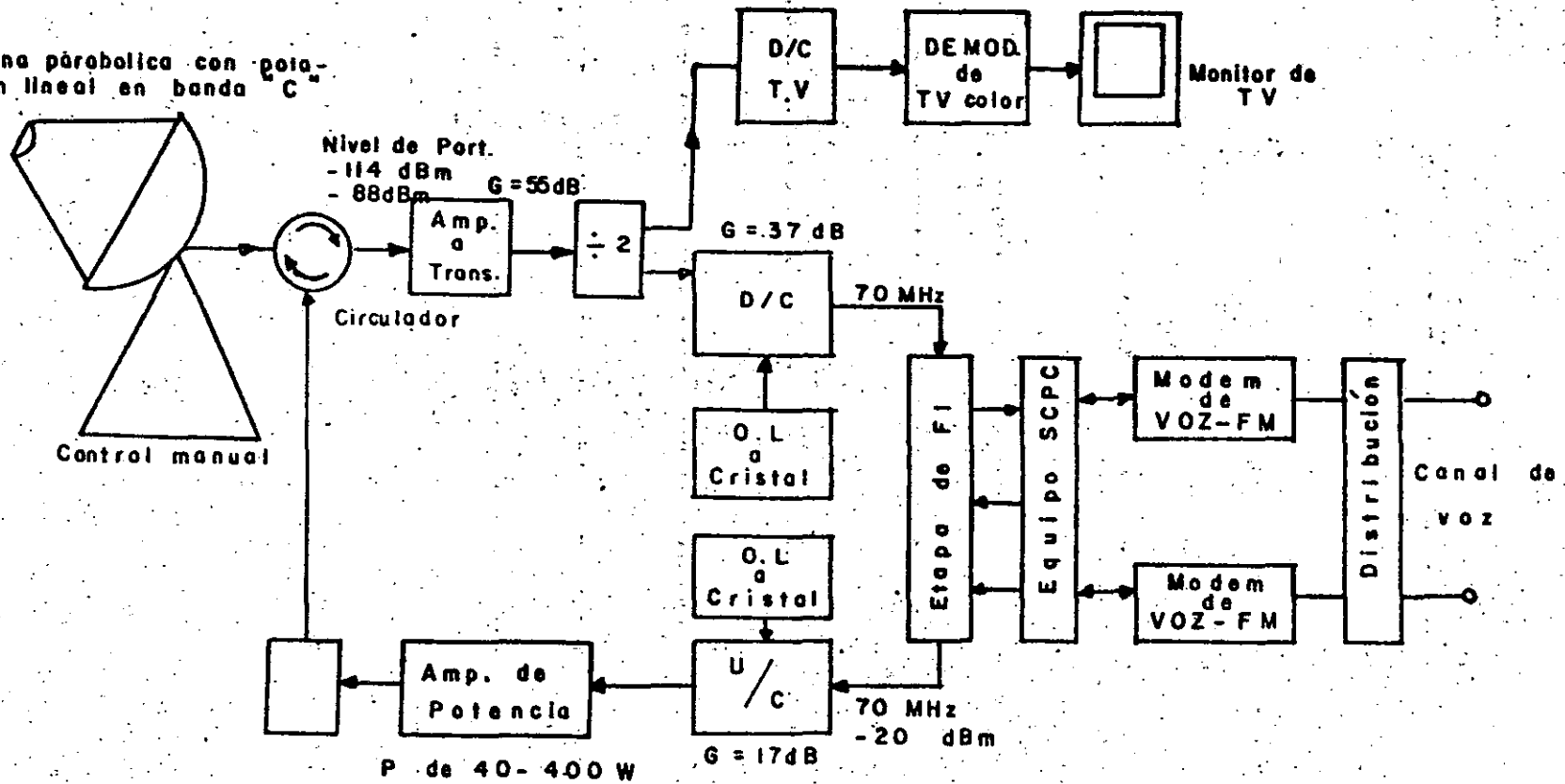


Fig. 15. Diagrama a bloques de una estación terrena de baja capacidad

TABLA 9
CAPACIDAD DEL SISTEMA

CAPACIDAD DE LA PORTADORA TERMINAL								CARACTERISTICAS ESPERADAS EN LA RECEPCION DE TV					
Tipo de Satélite	G/T Terminal	Voz FM de banda angosta			Datos PSK 2400 b/s cod. 3/4			TV Blanco y Negro			TV Cromatica		
		AP 10W	AP 100W	AP 400W	AP 10W	AP 100W	AP 400W	S/N	Grado	Calidad	S/N (C) bon.	Grado Taso	Calidad
ANIK	13.2 dB/K con T A	1 portadoras	2 portadoras	8 portadoras	1 portadoras	10 portadoras	40 portadoras	43.8	3 (d)	aceptable, equivalente a la clase B de la FCC (Radiodifusión áreas rurales D)	40.1	2	"Fina" para el 50% de los televidentes
WESTAR	20 dB/K con preamp. no enfriado	1 portadoras	8 portadoras	32 portadoras	6 portadoras	85 portadoras	280 portadoras	50.5	2	Fina, equivalente a la clase A de la FCC (Radiodifusión urbana)	46.9	1	Fina para el 98% de los televidentes o excelente para el 50%.
INTELSAT IV (Global)	13.2 dB/K con T A	(a)	(a)	(a)	(a)	(a)	1 portadora						
	20 dB/K con reamp no enfriado	(a)	(a)	(a)	(b) o portadora	1 portadora	4 portadoras						

CSC

- (a) No evaluados
- (b) Limitada por la potencia del transmisor de la estación terrena terminal
- (c) Razón de la señal de video pico a pico al ruido ponderado rms
- (d) S/N ponderado de 45 dB corresponden al grado y calidad indicada de aproximadamente 1 dB abajo del grado y calidad indicada.

Nota:

Los datos tabulados se basan en una eficiencia de la antena del 45%.
Eficiencia que ahora se proyecta sea del 55% en transmisión y del 60% en recepción.

Como se observa en la fig. (15), la pequeña terminal puede manejar hasta 32 portadoras empleando un amplificador de potencia de 400 watts y un preamplificador no enfriado. Se pueden utilizar 2400 bits por segundo con portadora PSK con un valor de código de $3/4$. Se pueden emplear hasta 40 portadoras con un amplificador a transistores (TRANSAMP) como el LNA.

Observese de la tabla (9) que las características de la TV esperadas varían desde "fina" a "aceptables", y en general proporciona un servicio que es aproximadamente el equivalente al de la calidad de la TV encontrada en la mayoría de los hogares, sin presencia de degradación o efectos por multitrayectoria o de interferencia los cuales son típicos de las transmisiones de TV comerciales que provienen de una estación con una antena alta situada en una comunidad metropolitana.

Los elementos básicos de una estación terrena de pequeña capacidad son los siguientes:

- 1 - Antena
- 2 - Amplificador de alta potencia (HPA)
- 3 - Amplificador de bajo ruido (LNA)
- 4 - Equipo de un solo canal por portadora (SCPC)
- 5 - Conversores ascendente y descendente U/C (D/C)
- 6 - Sistema receptor de TV

1) - Antenas - En la tabla (10) se muestran las características de antena para este tipo de estaciones terrenas pequeñas. Se observa una antena de 4.5 mts para la banda C (3.9 - 6.2 GHz) y una antena de 3 mts para la banda de 11.7 a 12.5 GHz. En la gama de 11/14 GHz se encuentran muy convenientes las antenas cuyo diámetro es de 3 mts, las cuales proporcionan una ganancia de aproximadamente 50 dBi en ambos modos, el de transmisión y el de recepción. Obsérvese que el ancho del haz a media potencia para ambos modos de la antena de 4.5 mts para la banda C es de aproximadamente 1°. Dado que la mayoría de los satélites se mantienen en una posición que no varía más de $\pm 0.3^\circ$, es evidente que las pequeñas antenas pueden operarse en forma manual, sin que se requiera un sistema automático de seguimiento.

CARACTERISTICAS TIPICAS DE ANTENAS

Tamaño del reflector	4.5 m	3 m.	1.20 m
Frecuencia (GHz)			
Recepción	3.7-4.2	11.7-12.5	1.5351-1.5435
Transmisión	5.925-6.425	14.0-14.3	16.365-16.450
Ganancia a media banda (dB)			
Recepción	43.7	45	23.5
Transmisión	46.8	50.4	23.5
VSWR máx	1.3:1	1.5:1	1.5:1
Ancho del haz a media potencia (°)			
Recepción	1.2	0.57	10
Transmisión	0.92	0.49	—
Primer lóbulo lateral	-15dB	-17dB	—
Potencia promedio de Trnsmisión (KW)	2	1.5	G/T=-4dB
Temperatura de ruido			
10° de elevación	35°	25°	100°K
40° de elevación	20°	10°	

2)- AMPLIFICADORES DE ALTA POTENCIA (HPA)

La tabla (11) muestra características típicas - para amplificadores de alta potencia de pequeñas estaciones

570

497

terrenas. Obsérvese en la tabla (11) la variedad de características para los HPA, que pueden adquirirse, incluyendo los HPA's de 10-40 watts, de 400-600 watts y los de 1.5-3 Kwatts. Estos dispositivos tienen ganancias típicas de 60-70 dB.

TABLA (11)

CARACTERISTICAS TIPICAS DE LOS HPA's

Potencia (saturada)	40 watts	400 watts	1.5 KW
Gama de frecuencias (GHz)	5.9-6.425	5.5-6.425	5.5-6.425
Ancho de banda a 1dB	banda ancha	banda ancha	TOP de banda ancha- Klystron -45MHz sintonizable
Ganancia de HPA más Amp. de			
Excitación	60-70dB	60-70dB	60-70dB
Potencia de excitación de			
Entrada (dBm)	0-5	0-5	0-5
Nivel de RF (dB)	20	20	20
Estabilidad de la ganancia			
dB/mes	0.5	0.5	0.25
Pendiente de ganancia (dB/MHz)	0.3	0.3	0.65
Salida de espurias en cualquier banda de 4 KHz en la banda de transmisión	-65dBw	-65dBw	-65dBw
VSWR de la carga	1.5:1	1.5:1	1.5:1
VSWR de entrada	1.2:1	1.3:1	1.3:1

Retardo de grupo			
Lineal	± 0.5 ns/MHz	± 0.5 ns/MHz	± 0.5 ns/MHz
Parabólico	0.05 ns/MHz ²	0.050 ns/MHz ²	0.05 ns/MHz ²
Rizo	2 ns p - p	2 ns p - p	2 ns p - p

Generalmente cuando se requieren potencias del orden de 40 watts a 3 kw, se emplean Klystrons o TOP's . Sin embargo, potencias inferiores a los 10 watts se pueden obtener mediante dispositivos semiconductores que existen acualmente en el mercado. Estos dispositivos incluyen a los --- amplificadores IMPATT y sistemas multiplicadores.

3) - AMPLIFICADOR DE BAJO NIVEL DE RUIDO (LNA)

En la tabla (12) se muestran las características típicas de los LNA's que se emplean en pequeñas estaciones terrenas.

TABLA (12)

CARACTERISTICAS DE LNA's TIPICOS

	amp. paramétrico enfriado termo- eléctricamente	amp. caliente	amp. FET
Gama de frecuencias (GHz)	3.7-4.2	3.7-4.2	3.7-4.2
Temperatura de ruido (°K)	45-55	90-150	200-250
	(50)	(100)	banda ancha 150 en 40 MHz de ancho de banda.
Ganancia (db)	60	60	60
Estabilidad en la ganancia dB por día	0.5	0.5	0.5

dB por mes	1.0	1.0	1.0
Temperatura ambiente (°C)	-50 a + 50	-50 a + 50	-50 a + 50
Compresión de ganancia de 0.5 db, Max. (dbm)	-60	-60	-60
Retardo de grupo Retardo lineal en una banda de 40 MHz	4ns	4ns	4ns
Rizo p - p	0.5ns	0.5ns	0.5ns
Intermodulación Dos portadoras con igual entrada de -64 dBm	60dB abajo	60dB abajo	60dB abajo

Se emplean tres dispositivos: El amplificador paramétrico enfriado termoeléctricamente, el amplificador paramétrico caliente (el cual opera a una temperatura elevada de -- aproximadamente 58°C) y el amplificador a FET.

Los param.s. enfriados termoeléctricamente operan con un diodo amplificador paramétrico y un circulador enfriado a una gama de temperatura de 0°C y -50°C . Dichos paramps. también utilizan una fuente de bombeo a diodo Gunn, operando a aproximadamente 60 GHz, para proporcionar temperaturas de ruido del orden de 45 a 55°K . Estos param.s. tienen circuladores especiales que presentan muy pocas pérdidas y un aislamiento inverso significativo para evitar el deterioro de la temperatura de ruido debido al VSWR de la antena de 1.5:1, el cual para un param.s. de 50° , puede degradar la temperatura de ruido en 70°K .

El paramp. caliente emplea una fuente de bombeo a 60 GHz, y puede proporcionar temperaturas de ruido del orden

de 90°K y 150°K, dependiendo de la complejidad del sistema. Dichos amplificadores son generalmente seguidos de amplificadores a transistores (transamps) para lograr una ganancia de 60 dB. Estos circuitos son en general muy confiables y se diseñan para operar a la intemperie con un mínimo de mantenimiento.

El amplificador a FET, es quizá la aportación más valiosa que se ha hecho en los últimos años, para poder diseñar un amplificador de bajo nivel de ruido que se pueda utilizar en una estación terrena de pequeñas dimensiones. Este amplificador proporciona una figura de ruido del orden de 90 -- 100 K en la banda de 3.7-4.2 GHz.

Una gran ventaja en este tipo de circuitos, es su bajo costo.

4) EQUIPO DE CONTROL DE TIERRA

En la mayoría de las estaciones terrenas pequeñas los conversores ascendentes y descendentes están integrados al equipo de procesamiento de la señal. En grandes terminales, tales como las de INTELSAT, los conversores deben de estar equipados para sintonizarse a cualquier canal del satélite. En algunos casos esta sintonía debe de realizarse en forma rápida y con una exactitud de 1 KHz con el fin de proporcionar una recepción adecuada.

En la mayoría de las pequeñas estaciones terminales la sintonía sobre un gran número de canales simplemente no se requiere. Con el fin de recibir un solo canal de un satélite, es económico emplear un filtro para el canal particular del

satélite y entonces utilizar técnicas de una sola conversión para obtener una FI de digamos 130 o 70 MHz. Lo mismo es válido para la trayectoria ascendente. De acuerdo con lo anterior el equipo de control de una pequeña estación terrena combina las funciones de conversión con el sistema de procesamiento de señal.

La tabla (13) muestra características de equipo típicas de un solo canal por portadora, mientras que la tabla (14) muestra las características típicas de receptores de TV.

5) UN SOLO CANAL POR PORTADORA (SCPC)

Un solo canal por portadora es mucho más eficiente que el FDM/FM desde ambos puntos de vista; el económico y el de aprovechamiento del espectro para rutas de pequeño tráfico ya se espera que esta técnica de comunicación sea la que se emplee en áreas que requieran menos de 12 canales telefónicos

6) RECEPTORES DE TV.

La tabla (14) presenta las características de los receptores de TV que pueden utilizarse para recibir radiodifusión de TV empleando FM con doble banda lateral desde un satélite.

TABLA (13)

CARACTERISTICAS TÍPICAS DE EQUIPO SCPC

EL EQUIPO SCPC NO INCLUYE CONVERSORES asc/desc.

- 1) Para una razón de portadora nominal a la densidad de ruido (C/No de 55 dB/Hz, el funcionamiento del circuito de voz será subjetivamente equivalente a un circuito

- 2) En un sistema FM, la razón tono de prueba a ruido debe ser de 33 dB con mensaje C ponderado y con preénfasis -- para una C/No de 55 dB/Hz. Debe de proporcionarse la -- curva que muestra las razones tono de prueba a ruido para $49 \text{ dB} \leq C/No \leq 61 \text{ dB}$.
- 3) En un sistema PSK los objetivos son que la razón señal a ruido de cuantización sea de 30dB o superior para un -- tono de prueba de 1 KHz a un nivel de entrada o de - 10 dBm para un BER de 10^{-3} . Este funcionamiento debe cum-- plirse para un BER de 10^{-4} . Debe de proporcionarse una curva que muestre las razones señal a ruido de cuantiza-- ción para $49 \text{ dB} \leq C/No \leq 61 \text{ dB}$.

TABLA (14)

CARACTERISTICAS DE RECEPTORES DE TV TIPICOS

Frecuencia de entrada	3.7 - 4.2 GHz
Gama de potencia de entrada	-85 dBm a - 60 dBm
Frecuencia intermedia	120 MHz
Respuesta de frecuencia de video	$\pm 0.5\text{dB}$ desde 50Hz a 4.2MHz $\pm 1\text{dB}$ max a 4.5 MHz
Deénfasis de video	Recomendación 405 - 1 del CCIR para el sistema de 525 líneas.
Nivel de salida de video	1 Volt $\pm 3\text{dB}$ pico a pico
Nivel de salida de audio	8 dBm $\pm 2 \text{ dB}$ en 600 ohms para una desviación pico-pico de 200 KHz.
Respuesta de frecuencia de audio	$\pm 2 \text{ dB}$, 50 Hz a 7500 Hz

3. TEMPERATURA DE RUIDO Y G/T

Temperatura de ruido.- La potencia del ruido generalmente se expresa en términos de su "temperatura de ruido".

Si cualquier equipo electrónico estuviera perfectamente aislado de interferencia externa, aun existiría ruido en él, originado por el movimiento aleatorio de los electrones. A este ruido se le conoce como ruido térmico. Este ruido siempre existe en el fondo de toda proceso electrónico. Al incrementarse la temperatura, el movimiento de los electrones también se incrementa, aumentando la potencia del ruido térmico.

La potencia del ruido térmico que afecta a una gama de frecuencias es proporcional a la temperatura absoluta y al ancho de banda en cuestión:

La potencia del ruido térmico puede expresarse como

$$P_N = k TW \quad (3)$$

donde

P_N = Potencia de ruido en watts.

K = Constante de Boltzman, 1.380×10^{-23} watts -
seg. /K

T = Temperatura en K del sistema

W = Ancho de banda, en Hz

La temperatura de ruido de una fuente ruidosa es la temperatura que produce la misma potencia de ruido sobre la misma gama de frecuencias.

Así si una fuente origina un ruido de potencia P_N , su temperatura de ruido, en algunas ocasiones se le llama -- temperatura de ruido equivalente, ENT, y esto es

$$T = \frac{P_N}{k W} \quad (4)$$

8.1. DENSIDAD DE RUIDO

El término densidad de ruido se aplica al ruido por Hz de ancho de banda, o sea

$$\text{Densidad de ruido} = \frac{P_N}{W} = k T \quad (5)$$

8.2. FIGURA DE MERITO $\frac{G}{T}$

Debido a la pequeña señal recibida tanto en el satélite como en la estación terrena, es importante que tanto la antena receptora como la electrónica de la estación introduzcan un ruido tan pequeño como sea posible. Para evitar pérdidas y ruido en las líneas de transmisión que conectan la antena receptora a las circuitos electrónicas, generalmente la antena tiene un preamplificador colocado en el foco geométrico de la parábola como se muestra en la fig. (1). La eficiencia de esta combinación se expresa como la razón de la ganancia a la temperatura de ruido y se le conoce como figura de mérito, esto es:

$$\text{Figura de merito} = \frac{G}{T}$$

Donde:

G = Ganancia del preamplificador y de la antena

T = Temperatura de ruido recibida por el sistema

Esta figura de mérito está relacionada con la razón señal a ruido e indica la capacidad relativa del subsistema - receptor para recibir una señal.

En la fig. (16) se presenta una gráfica en la cual se muestran algunos valores típicos de G/T para receptores - con electrónica no enfriada.

Para medir la temperatura de ruido de una antena, - debe emplearse un radiómetro. La G/T puede obtenerse tomando la razón de la ganancia de la antena entre la temperatura de ruido de la antena T medida con el radiómetro.

Existe un método para medir la G/T directamente -- empleando las fuentes de radio celestes. Si la razón del -- nivel de ruido de la fuente de radio recibida por el receptor al nivel de ruido recibido cuando la antena se dirige hacia - otro punto, es r , entonces la G/T estará dada por:

$$\frac{G}{T} = \frac{8\pi k}{S \lambda^2} (MK) (r-1) \quad (7)$$

Donde:

S Es la densidad de flujo de potencia de la fuente de radio.

k Es la constante de Boltzman,

M Es el factor de corrección que se requiere debido a que la fuente de radio celeste no es una - fuente puntual.

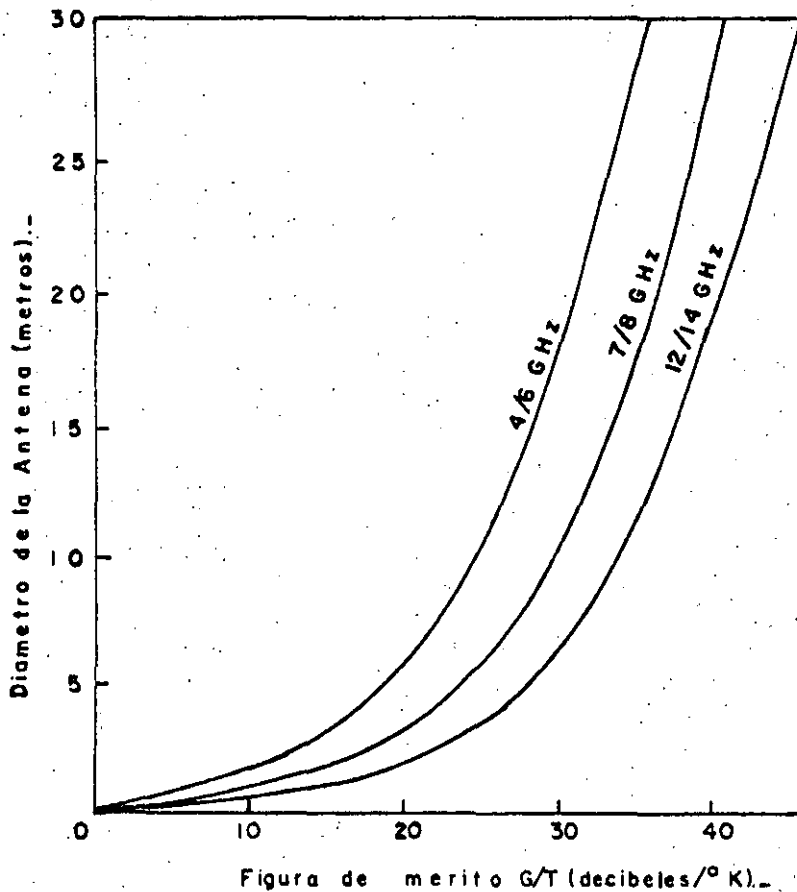


FIG. 16.- Figuras de mérito típica G/T de estaciones terrenas, calculadas considerando un receptor con electrónica no enfriada y una temperatura de ruido de 316°K.

K Es el coeficiente para corregir la pérdida de absorción de la atmósfera la cual está dada por la siguiente ecuación para un ángulo de elevación.

K = a cosec θ (8)

Donde: a es la constante de absorción en el cenit y tiene el valor de 0.036 dB en la banda de 4 GHz y 0.045 dB en la banda de 6 GHz. Es necesario tomar en cuenta la atenuación por refracción y la atenuación por difusión, especialmente en el caso donde el ángulo de elevación es menor de 10°.

La fig. (17) muestra los valores del factor de corrección M. y la tabla (15) presenta las fuentes de radio celestes típicas.

Fig.17 .

Factor de Corrección

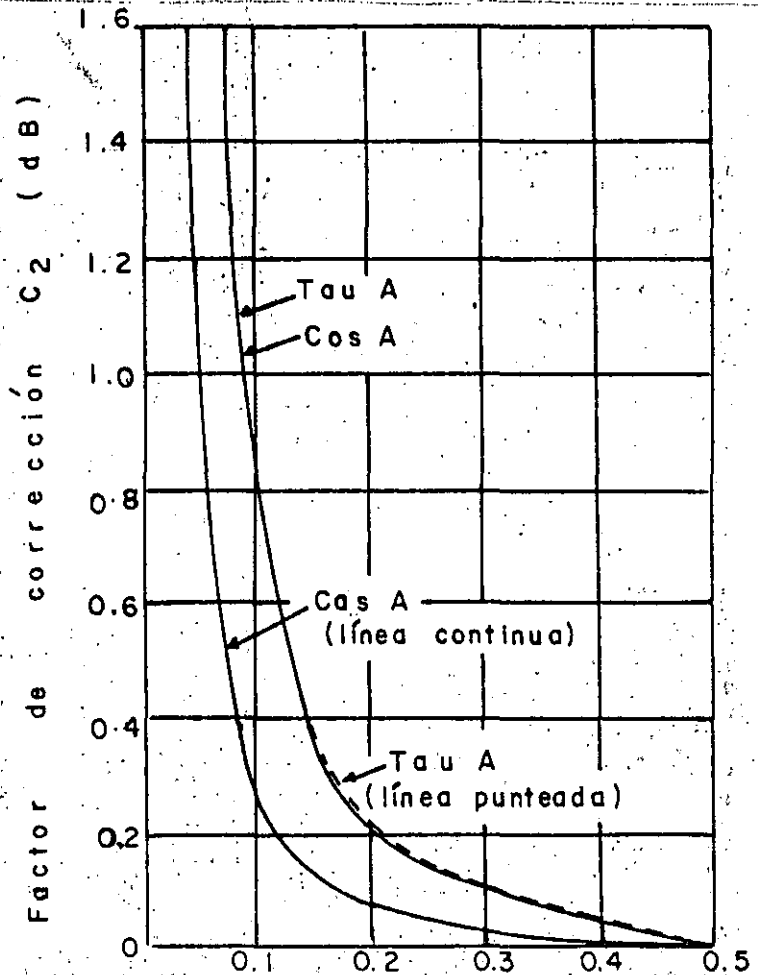


TABLA 15

Fuente de radio	Ubicación (a)		Forma	Tamaño	Índice espectral (b)	Polarización		Densidad de flujo $Wm^{-2}Hz^{-1}10^{-2}$	
	Perturbación					4170 MHz	6390 MHz	4000 MHz	6390 MHz
	ascension recta	declinación							
Cas A	$23h21m11.4s$ 2.71s	$58^{\circ}31.9'$ 0.33'	anular	4' de diámetro	-0.792	-	-	1067 (c)	774
Tau A	$0.5h31m30s$ 3.61s	$21^{\circ}59.3'$ 0.04'	elíptica. (Gaussiana)	eje mayor 4.3' eje menor 2.7'	-0.287	$\frac{5.7\%}{143^{\circ}}$	$\frac{7.0\%}{147^{\circ}}$	679	604
Cyg A	$19h57m44.5s$ 2.08 s	$40^{\circ}35.8'$ 0.16'	fuelle puntual doble	2' de separación	-1.198	$\frac{3.0\%}{1.60^{\circ}}$	$\frac{5.7\%}{148^{\circ}}$	483	29

(a) Perturbación por . Ubicación (1950 + X) = Ubicación (1950) + perturbación X

(b) 1-16 GHz.

(c) Valor para enero de 1965.

508

Para el caso de pequeñas estaciones terrenas empleadas para un solo usuario o una pequeña comunidad, el factor de mérito debe ser igual o superior 6 dB/K.

El factor de mérito de la estación receptora se puede calcular mediante la siguiente expresión

$$\frac{G}{T} = \frac{\alpha \beta G_a}{\alpha T_a + (F - \alpha) T_o} \quad \text{dB/}^\circ\text{K} \quad (9)$$

Donde:

α = Atenuación entre el alimentador de la antena y la entrada al receptor.

β = Factor de pérdidas debido a error de orientación de la antena y al desacoplamiento de la polarización.

G_a = Ganancia efectiva de la antena

T_a = Temperatura de ruido de la antena en K

F = Factor de ruido del receptor

T_o = Temperatura de referencia (290° K)

Para una antena parabólica, la ganancia en potencia se expresa mediante la siguiente fórmula:

$$G_a = \eta \left(\frac{\pi D}{\lambda} \right)^2 \quad (10)$$

Donde:

η = Eficiencia de la antena (que puede considerarse de 0.54 a 0.65)

D = Diametro del reflector parabólico

λ = Longitud de onda

Para antenas fijas se ha estimado que el error de orientación del eje del lóbulo principal está entre 0.4° (en el mejor de los casos) y 0.7° (en el peor de los casos) por lo que es razonable tomar un valor de $\xi = 0.6^\circ$. El factor de pérdidas β debido a este error está dado por

$$\beta = Q^{-2.764} \left(\frac{\xi}{\phi_0} \right)^2 \quad (11)$$

Donde:

ϕ_0 = Al ancho del haz (se toma a puntos en donde la señal a caído 3 dB con respecto al valor máximo).

$$\phi_0 = \frac{4\lambda}{\pi D} \text{ rad} = \frac{720 \lambda}{\pi^2 D} \text{ grados} \quad (12)$$

La temperatura de ruido de la antena T_a depende del ángulo de elevación de la antena y de su diámetro. (Un valor típico es de 60°K).

La atenuación α debida al polarizador y al filtro de R F puede considerarse como 1 dB. La tabla siguiente muestra algunos valores de F en función del diámetro de las antenas para obtener un factor de calidad mínimo de $\frac{G}{T} = 6 \text{ dB}/^\circ\text{K}$

~~584~~

TABLA . . 15

Diámetro (m)	Factor de ruido (dB)
0.8	6.23
0.9	6.91
1.0	7.50
1.1	7.98
1.2	8.39

9. Obtención de coordenadas para la localización de un satélite geoestacionario.

La obtención de coordenadas para localizar un satélite doméstico mediante una antena parabólica, es de suma -- importancia y merece una atención especial, ya que cualquier estación terrena chica, mediana o grande debe de tener algún método para la localización de los satélites de interés.

Los satélites domésticos son geosíncronos y están -- localizados sobre el ecuador. Para un observador que se encuentra en el hemisferio norte, los satélites parecerán encontrarse hacia el sur en el cielo. Cuando una antena está localizada muy hacia el norte el ángulo de elevación de la antena tenderá a aproximarse a cero grados, al apuntarse hacia el sur. Para antenas de 7 metros o menores, el ancho del haz -- es grande por lo que el ángulo de elevación es el más importante y este ángulo depende primordialmente de la latitud en la que se encuentre la estación terrena.

El ángulo de azimut variara porque los satélites -- geosíncronos están localizados a diferentes longitudes. Para un observador en el hemisferio norte, un satélite en parti -- cular aparecerá al oeste o al este mirando hacia el sur.

Para recibir señales de diferentes satélites, deben de ajustarse estos ángulos de elevación y azimut correctamente, que son los más importantes, sin embargo, existe un tercer movimiento angular que tiene gran importancia para que la señal recibida sea clara. Este movimiento es en el alimentador de la antena y que se encuentra en el foco de ésta. La

forma en que se obtienen estos ángulos y los ajustes que se deben hacer se describen en este apartado.

Solo queda un comentario por hacer antes de comenzar estas descripciones, y es la forma en que se toman los datos para realizar los cálculos.

Se considera que la latitud es positiva hacia el norte del ecuador y negativa para el hemisferio sur. La longitud es positiva al oeste (W) del primer meridiano y negativa para el este. Existe un fenómeno natural que es la declinación magnética y que hay que considerar. La declinación magnética es la desviación en grados que existe entre el norte geográfico y el norte magnético que nos da una brújula. Como normalmente se utiliza una brújula para orientar en azimut a la antena hay que considerar la declinación magnética, ésta es positiva hacia el este y negativa hacia el oeste del polo norte.

9.1. Parámetros geométricos con respecto a una estación terrena y un satélite en órbita.

Los dos parámetros geométricos básicos que se desean obtener para una estación terrena con respecto a un satélite en órbita geosíncrono, son el ángulo de elevación y el ángulo de azimut .

Existen otros parámetros que también se pueden obtener, como son el ángulo entre la estación terrena y la perpendicular del satélite sobre el ecuador visto desde el satélite o el ángulo visto desde el centro de la tierra. Para comprender mejor lo dicho anteriormente nos basaremos en la figura -

(18); En la figura, "O" representa el centro de la tierra, S un satélite geosíncrono a una altura H, y Q un punto sobre el ecuador que resulta al trazar una línea desde el satélite hasta el centro de la tierra. La fracción de la superficie terrestre vista desde el satélite que se genera al circundar el punto Q' se le conoce como cobertura del satélite, la --- cual es aproximadamente 42.5 % de la superficie total de la tierra.

El punto se obtiene al trazar una línea desde el --- satélite tangente a la superficie de la tierra.

En la fig. (18) S representa el satélite goestacionario, E representa a la estación terrena, β es el -- ángulo formado por la línea que partiendo del centro de la tierra pasa por E y la línea que va desde el satélite hasta el centro de la tierra, y $\Delta\phi$ es la distancia angular de longitudes entre la estación terrena E y Q sobre la superficie de la tierra, y medida sobre el ecuador. El ángulo de elevación θ está dado por la horizontal de la superficie terrestre y la posición del satélite en el espacio y λ representa la longitud o distancia entre la estación terrena y el satélite. Como se observa en la figura, todos estos parámetros -- pueden obtenerse por medio de Trigonometría esférica ya que los triángulos formados son esféricos, y algunos triángulos rectángulos. Para nuestro caso solo aplicaremos algunas --- ecuaciones sencillas para la obtención de los parámetros mencionados con anterioridad.

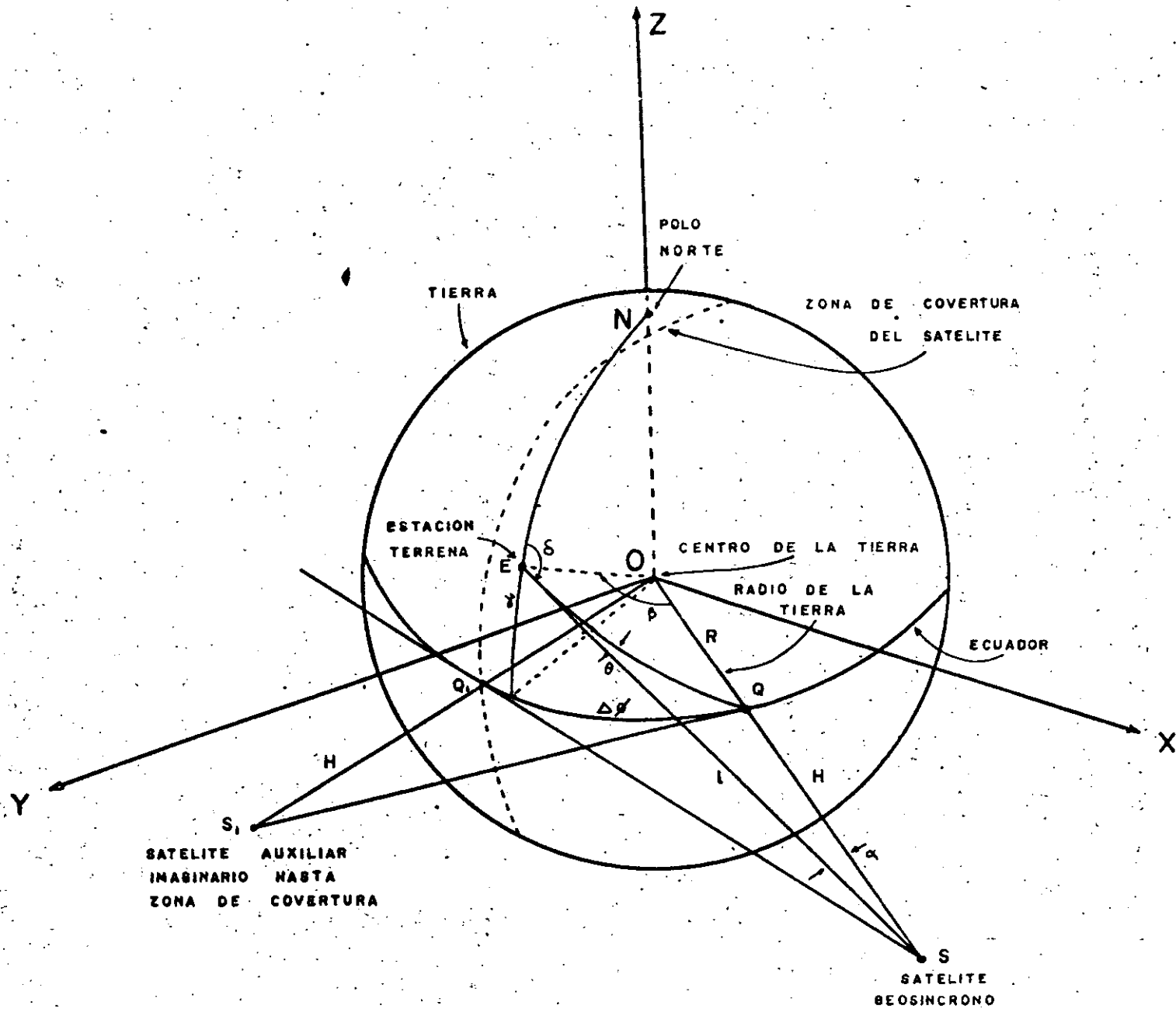


Fig. 18 (a) Geometría de la tierra y de un satélite en órbita.

508

515

583

- R = Radio terrestre 6378 Km. (valor medio)
 H = Altitud del satélite en forma perpendicular sobre el ecuador. 35786 Km. (valor medio)
 l = Distancia entre la estación terrena y el satélite.
 θ = Angulo de elevación de la antena de la estación terrena con respecto a la horizontal.
 δ = Latitud de la estación terrena.
 $\Delta\phi$ = Diferencia de longitud entre la estación terrena y el satélite.
 β = Distancia angular entre la estación terrena y Q sobre la superficie de la tierra.
 α = Angulo entre la estación terrena y la perpendicular del satélite sobre el ecuador, visto desde el satélite
 δ = Angulo de azimut.
 S = Posición del satélite geosíncrono en órbita terrestre.
 S_1 } Puntos auxiliares para formar las trazas auxiliares en
 Q } la formación de triángulos semejantes y obtener los
 Q_1 } parámetros geométricos, dentro de la cobertura del
 O } satélite.

Todos los parámetros geométricos están dados por las siguientes ecuaciones:

$$\text{sen } (\alpha) = \frac{R}{l} \text{ sen } (\beta) \quad (13)$$

$$\text{cos } (\beta) = \text{cos } (\theta) \text{ cos } (\Delta\phi) \quad (14)$$

$$\cos (\theta) = \frac{(R+H)}{L} \sin (\beta) \Rightarrow \theta = \arccos \left(\frac{(R+H)}{L} \sin (\beta) \right) \quad (15)$$

$$L = \left[R^2 + (R+H)^2 - 2 R (R+H) \cos (\beta) \right]^{1/2} \quad (16)$$

$$\tan (\delta) = \frac{\tan (\Delta\phi)}{\sin (\gamma)} \quad (17)$$

$$\delta = \arctan (\tan \delta) \quad (18)$$

Ejemplo:

En este ejemplo se obtendrán los ángulos de elevación y azimut para orientar una antena hacia un satélite específico, mediante un método matemático.

Partiendo de la posición conocida del satélite y de las coordenadas de la estación terrena, tenemos que el satélite que deseamos recibir, es el SATCOM F3, el cual sabemos que tiene una posición de:

$$\phi_s = 131 \text{ W (longitud del satélite)}$$

Y nuestra estación terrena se encuentra en la posición de:

$$\phi_E = 99^\circ \text{ (longitud)}$$

$$\gamma = 19.5^\circ \text{ (latitud)}$$

Para determinar el ángulo de elevación que debe tener la antena en nuestra estación terrena, procedemos de la manera siguiente:

De la ecuación (14) se tiene que: (ver fig. 18a)

$$\cos \beta = \cos \gamma \times \cos \Delta\phi$$

$$\Delta\phi = \phi_E - \phi_s$$

Para nuestro caso se tiene que:

$$\phi_E - \phi_s = 99^\circ - 131^\circ = -32^\circ, \text{ o sea que}$$

$$\Delta\phi = -32^\circ$$

$$\cos \Delta\phi = 0.8480$$

Substituyendo valores en la ecuación (14) tenemos

$$\cos \beta = \cos 19.5^\circ \cos (-32^\circ)$$

$$= (0.9426) (0.8480) = 0.7994$$

$$\therefore \beta = 36.9266^\circ \quad \text{sen } \beta = 0.60079$$

Aplicando la ecuación (16), se tiene que

$$l = \left[(6378)^2 + (6378+35786)^2 - 2(6378)(6378+35786) \right. \\ \left. (0.7994) \right]^{1/2}$$

$$l = 37,262.937 \text{ Kms.}$$

Aplicando ahora la ecuación (15), tenemos

$$\cos \theta = \left(\frac{6378 + 35786}{37262.937} \right) (0.60079) = 0.6798$$

$$\therefore \theta = 47.171^\circ$$

Este ángulo es el de elevación requerido para nuestra antena receptora en el punto considerado.

Para calcular el ángulo azimutal, partimos de la ecuación (17)

$$\text{Tang } \delta = \frac{\text{tang } \Delta\phi}{\cos \beta}$$

Substituyendo valores

$$\text{Tang } \delta = \frac{\text{tang } (-32^\circ)}{\text{Sen } 19.5^\circ} = \frac{-0.6248}{0.3338} = -1.8719$$

$$\therefore \delta = -61.888^\circ$$

El ángulo azimutal requerido por nuestra antena - será Az, el cual se determina mediante la siguiente consideración:

$$\text{Az} = 180^\circ - \delta = 180^\circ + 61.88^\circ = 241.88^\circ$$

Este ángulo se considera con respecto al norte geográfico de la tierra.

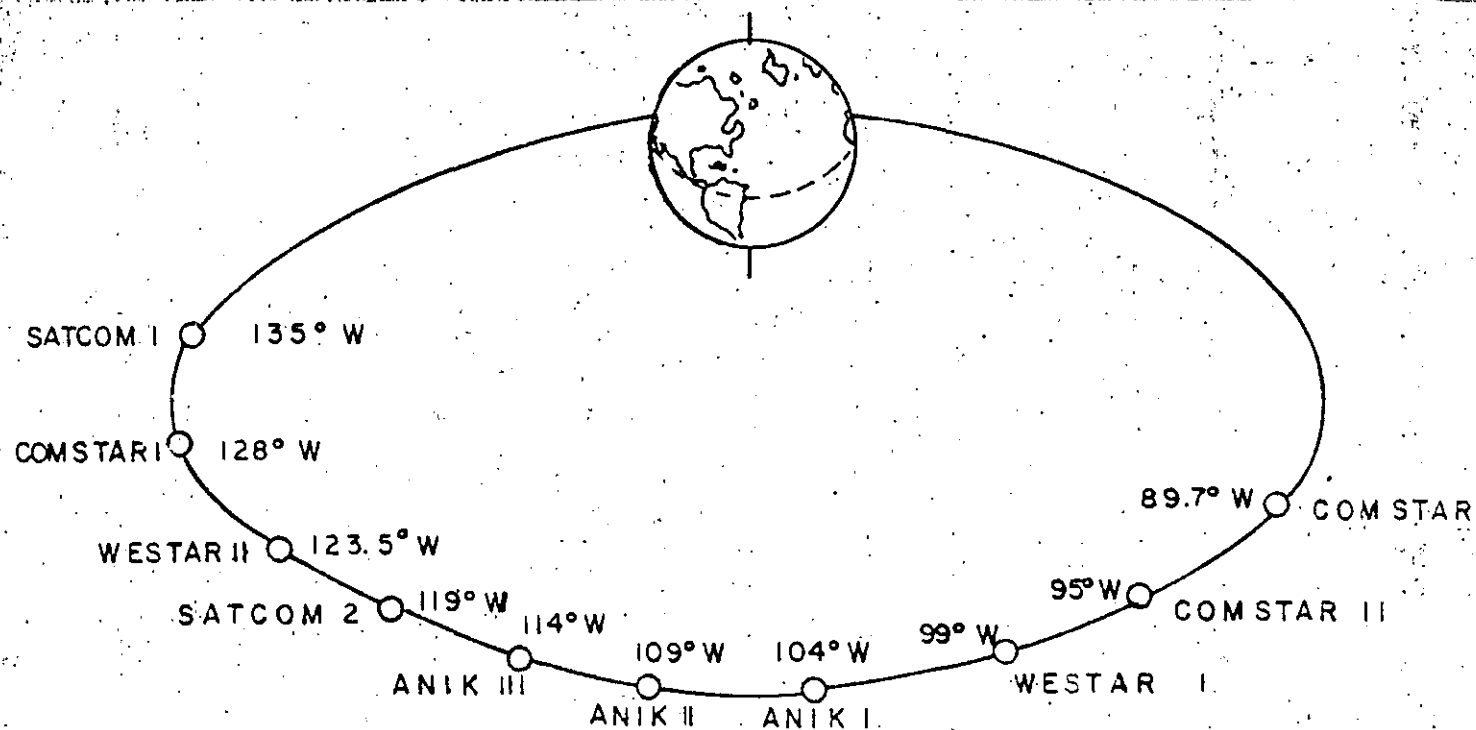


Fig. 18 (b) Ubicación de las satélites con orbitas

10. Obtención de los ángulos de elevación y azimut en forma gráfica para orientar una antena parabólica.

Los ángulos de elevación y azimut de una antena parabólica dependen de la ubicación geográfica que tenga la estación terrena, o sea de su latitud y longitud, y la posición orbital que tenga el satélite en su longitud ya que la latitud para los satélites geosíncronos será siempre de cero grados.

En la figura (19) se muestra una carta completa con la cual podemos obtener estos ángulos, para cualquier lugar de la tierra en que se encuentre la antena, dentro de la cobertura del satélite.

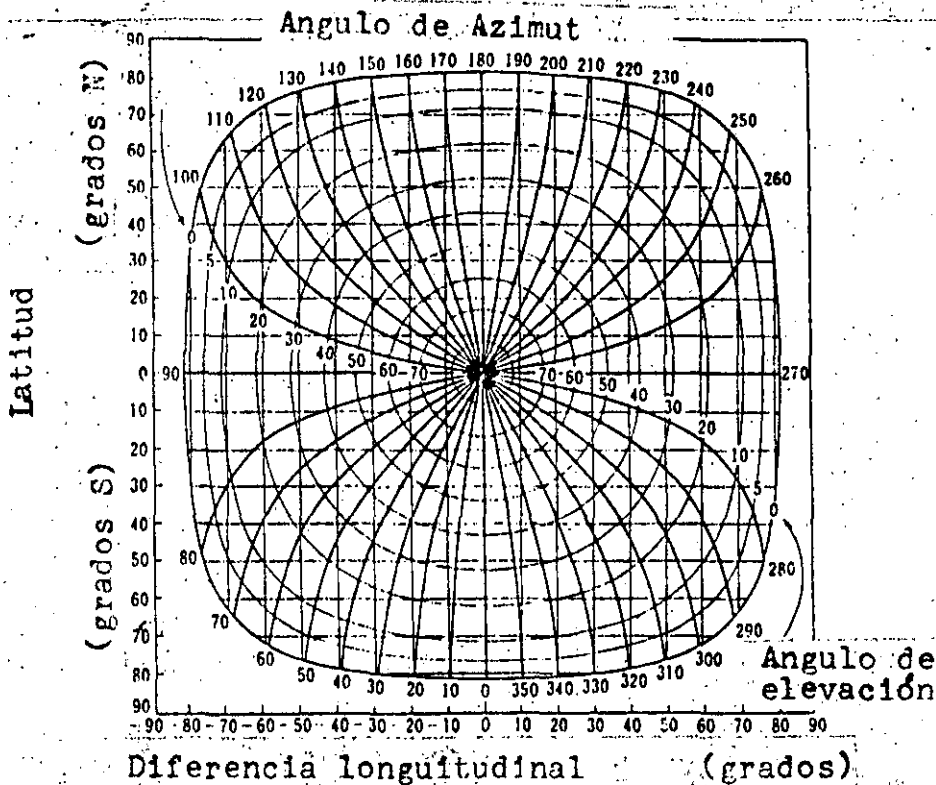


Fig. 19. Relación entre la ubicación de la estación terrena y un satélite geosíncrono

Si observamos la carta nos damos cuenta de que ésta está dividida en cuadrantes y cada uno de ellos tiene cierta similitud, por lo que con las gráficas de un solo cuadrante - podemos obtener estos dos ángulos. Es importante tomar en - cuenta el cuadrante que se esté inspeccionando ya que de esto depende el agregar o sustraer 90° o 180° a las lecturas - obtenidas y poder localizar correctamente al satélite en cues-
tión.

Las figuras (20) y (21) muestran las gráficas - para obtener el ángulo de elevación y el ángulo de azimut, - respectivamente. Aunque también existen cartas en las que se tienen las dos cartas juntas como la que se muestra en la fi-
gura (22) .

El primer paso consiste en saber la ubicación geo--
gráfica de la antena, referidos a un punto.

- Latitud (Norte o Sur)
- Longitud (Este u Oeste)

El siguiente paso consiste en saber la ubicación --
geográfica del satélite deseado del cual se quiera recibir la
señal.

- Longitud del satélite.

Para obtener los ángulos con precisión es necesario contar con una carta como la descrita anteriormente.

595

522

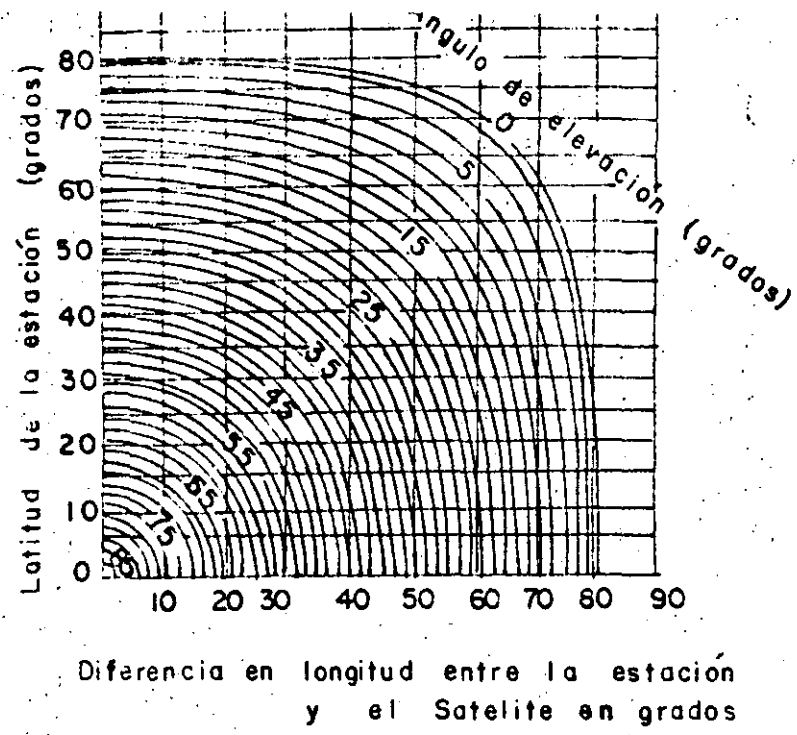


Fig. 20. Gráfica para obtener el ángulo de elevación.

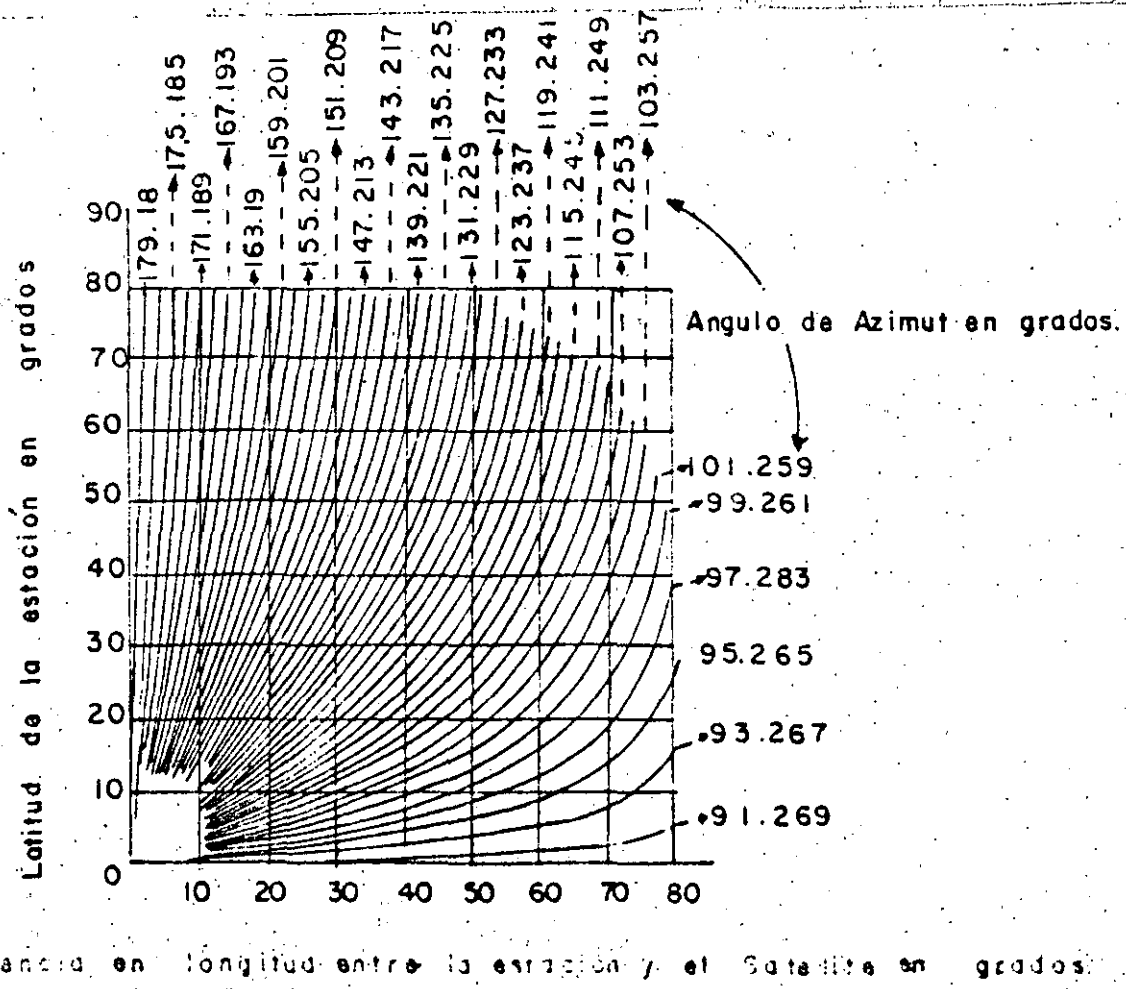


Fig. 21. Gráfica para obtener el ángulo de azimut.

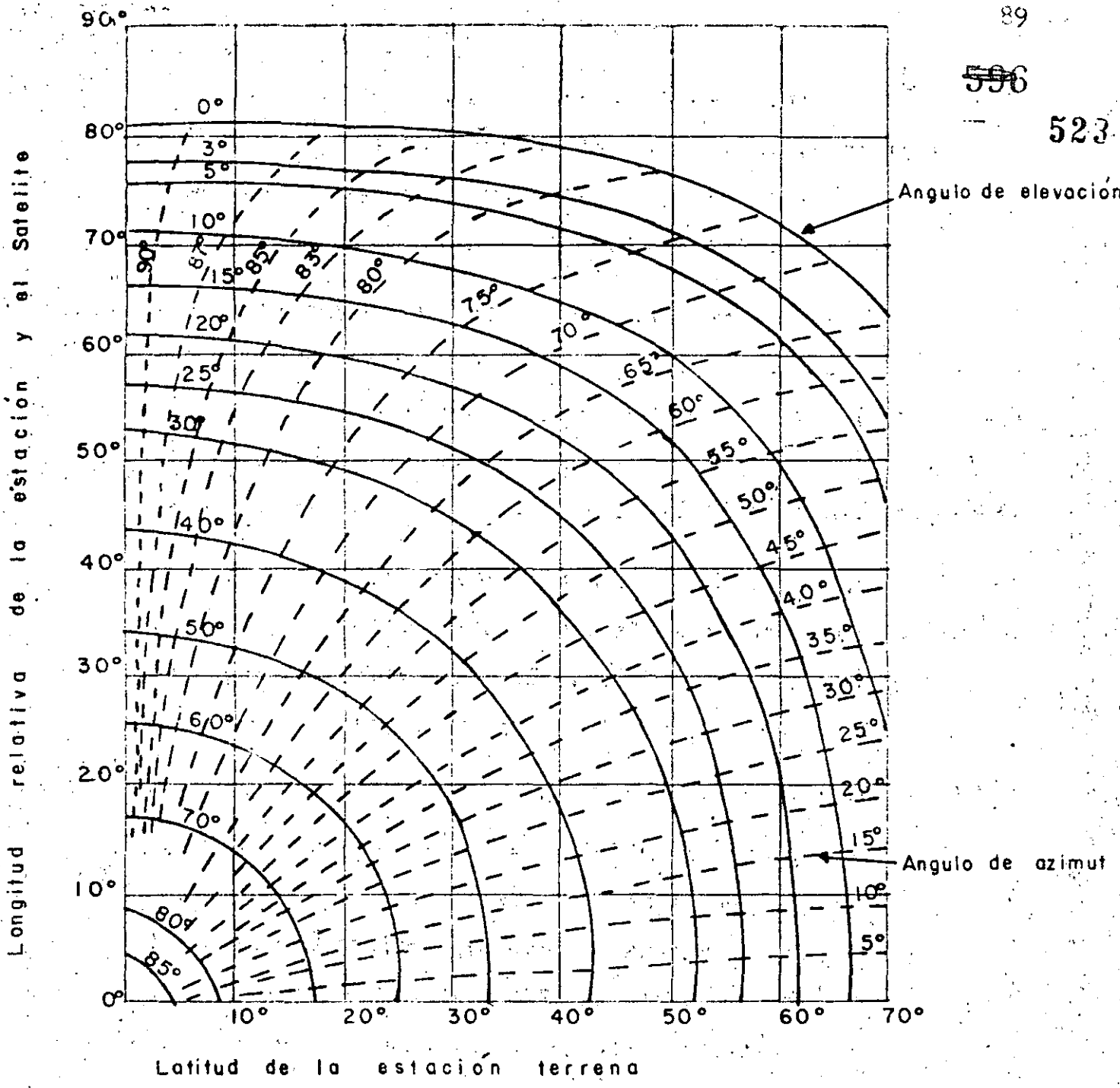


Fig. 22. Gráfica para obtener los ángulos de elevación y azimut de un satélite.

La carta que emplearemos consta de un solo cuadrante, sin embargo, es más que suficiente para la obtención de estos ángulos ya que en este cuadrante se encuentra ubicada la mayor parte del Territorio Nacional.

En esta carta (ver fig. 22) se tienen dos ejes, el vertical que marca la longitud relativa de la estación terrena esta longitud relativa es la resta de la longitud del satélite menos la longitud de la estación terrena y en el eje horizontal se tiene la latitud real de la estación terrena.

La fig. (20) que parece tener círculos concéntricos sirve para obtener el ángulo de elevación de la antena y la gráfica de la fig. (21) en la que aparecen curvas que coinciden en el origen, nos da el ángulo de azimut de la antena.

Otro punto de interés que hay que tomar en cuenta es la declinación magnética de la tierra en el lugar donde se encuentre ubicada la antena, ya que para orientarla se utiliza generalmente una brújula en el movimiento de azimut, a menos de que se tenga una situación de la antena con puntos cardinales absolutos o el norte astronómico y por lo tanto será necesario sumar o restar la cantidad de grados de la declinación magnética del lugar.

Los datos con los que se entre a la carta se consideran positivos si la latitud es hacia el norte y la longitud hacia el oeste. La declinación magnética es positiva al este del polo norte y negativa al oeste del polo norte.

11. Ejemplos de la obtención de los ángulos en forma gráfica.

Situación geográfica de la antena Ciudad de México

- Latitud 19.5° Norte
- Longitud 99° Oeste
- Declinación magnética 7°

Situación geográfica del satélite.

SATCOM F 3 Longitud 131°

Utilizaremos la carta de la fig. (22) que tiene las dos curvas para el ángulo de elevación y para el de - - azimut .

En el eje horizontal de la carta, localizamos la - latitud de la Ciudad de México 19.5° y trazamos una vertical.

A continuación necesitamos la longitud rotativa de la estación terrena y del satélite.

Longitud del satélite	131°
Longitud de la Cd. de Méx	<u>99°</u>
Longitud relativa	32°

Con este dato obtenido, lo marcamos sobre el eje - vertical y trazamos una horizontal, hasta cruzarse con la -- línea trazada anteriormente.

Las dos rectas se intersectan en un punto, en este punto se hacen pasar curvas concéntricas que corresponden a los ángulos de elevación, obteniéndose de esta manera el ángu-

lo de elevación que es de 47.5° .

Las curvas que inciden al centro nos dan el ángulo de azimut , y una curva que pasa por el punto nos indica un ángulo de 63° . Hay que sumar 180° más a la lectura obtenida para la posición correcta de la antena.

$63^{\circ} + 180^{\circ} = 243^{\circ}$ - - - - - Angulo total de azimut
con respecto al el norte
geográfico.

Por lo tanto los ángulos de elevación y azimut -
son

Azimut ----- 243°
Elevación ----- 47.5°

Cuando se mueve la antena en azimut habrá que --
sumar los grados de la declinación magnética de la tierra -
que se tenga en ese lugar.

12. Consideraciones prácticas en la orientación de una
antena.

Después de haber obtenido los ángulos de elevación
y azimut para una antena, es necesario el orientarla en una
forma física. Al hacerlo hay que considerar que los valo -
res de los ángulos obtenidos no son exactos para el lugar en
particular, debido a que la tierra no es completamente redon
da y que existen pequeñas variaciones en la posición del --
satélite. Los ángulos obtenidos variarían en un pequeño va-
lor; por lo que es necesario el efectuar pequeños ajustes -
tanto en elevación como en azimut , después de que la antena

~~500~~

ha sido orientada con los ángulos obtenidos por algún método de los vistos anteriormente.

Para estaciones terrenas de gran tamaño se utilizan servomecanismos de control azimut en elevación, así como en el alimentador, y generalmente este control es en forma automática y continua, para poder corregir instantáneamente las variaciones que se tengan en cualquier momento.

Por otra parte se tienen las estaciones terrenas de pequeño tamaño, en la que los diámetros de las antenas parabólicas son del orden de 10 mts. o menores.

Estas pequeñas estaciones terrenas son generalmente fijas y están orientadas a un satélite en particular no contando con servomecanismos para seguir al satélite. Como existen actualmente un gran número de estaciones pequeñas; es conveniente el comentar como se deben de efectuar los ajustes para recibir una señal de buena calidad.

Para hacer los ajustes finos es necesario que se tenga el equipo receptor operando en buenas condiciones y que esté cercano a la antena para detectar los cambios en el nivel de recepción de la señal. La línea de transmisión que se esté utilizando debe de tener la menor longitud posible entre la antena y el receptor para que las pérdidas sean mínimas y la cantidad de ruido sea pequeño. Bajo estas condiciones es posible hacer los ajustes finos necesarios para la recepción de señal con el máximo nivel. Al receptor hay que sintonizarlo de preferencia en los canales pares que son los de más bajo nivel en la señal recibida. Para darnos cuenta -

del nivel con que llega la señal, generalmente al receptor - incluye un medidor de intensidad de campo relativo diseñado - para éste fin.

12.1. Ajustes en el ángulo de elevación.

Suponemos que la antena ha sido orientada tanto en elevación como en azimut con los ángulos calculados.

El ajuste en el ángulo de elevación es el más crítico por lo que se debe de orientar la antena lo más preciso posible ya que como se ha visto anteriormente, el ancho del haz que tiene la antena es muy pequeño y fácilmente se puede perder la señal del satélite. Al primer intento de la localización de un satélite en elevación se le llama ajuste burdo y para hacerlo se requiere de un medidor de inclinación o pendiente que se adhiere a la antena. Se puede improvisar un medidor de inclinación con un transportador y una plomada para que nos indique la inclinación que tenga la antena.

Hay que recordar que el ángulo de elevación se mide con respecto al horizonte en donde se tiene una inclinación de cero grados, y cuando la antena esta orientada con la abertura de la parábola hacia el cielo en una forma vertical, se tendrá una inclinación de 90 grados.

Una vez que la antena ha sido orientada en forma burda, se procede a un ajuste fino en su ángulo de elevación. Para hacer este ajuste, normalmente las antenas fijas cuentan con unos tornillos para este ajuste que controlan el ángulo de elevación, por lo que el ajuste fino se hace moviendo estos tornillos ya sea elevando o bajando la antena en una can-

602

tividad pequeña de grados, generalmente el máximo desplazamiento es de dos grados. En la posición en que se recibe la señal con la mejor calidad, se sujeta firmemente la antena.

12.2 Ajuste en el ángulo de azimut .

Los ajustes que se hacen en el ángulo de azimut se efectúan siguiendo un procedimiento análogo al que se utilizó en el ajuste del ángulo de elevación; es decir, se localiza el ángulo de azimut calculado que es la forma burda, y después se procede a un ajuste fino hasta lograr la señal con la mejor calidad, afianzándose la antena firmemente para evitar un posible movimiento accidental. Con estos dos ajustes se obtiene generalmente la mejor señal del satélite, detectándola con el medidor relativo de nivel con que cuenta el receptor, o con un monitor de TV ya que las señales recibidas son en su mayoría de TV.

12.3 Ajuste en el alimentador

El último ajuste que queda por hacer es el ajuste en el alimentador que se encuentra en el foco de la parábola, este ajuste hay que hacerlo después de haber hecho los ajustes finos de los ángulos de elevación y azimut . El ajuste de alimentador se hace con la finalidad de alinear las guías de onda del polarizador con la onda electromagnética proveniente del satélite, que normalmente para transmisiones de señales de televisión utiliza una polarización lineal. Con este último ajuste, se puede garantizar la optima recepción de la señal proveniente del satélite.

El tipo de pequeña estación terrena que únicamente recibe televisión (TVRO) es quizá una de las de mayor importancia, debido a la enorme cantidad de estas estaciones que se han instalado, se están instalando y se instalarán en el futuro para recibir la radio difusión de TV directa.

Actualmente se cuenta con varios satélites que proporcionan señales de TV las 24 horas del día y entre los más populares se tienen entre otros a los SATCOM I, y II, los WESTAR I y II, los COMSTAR I, II, III, etc.

Estos satélites son geostacionarios y su ubicación se puede observar en la fig (18b) . La frecuencia de operación se encuentra en la banda de 4/6 GHz, siendo la banda de frecuencia de ascenso de 5.9 a 6.4 GHz y la banda de frecuencia de descenso de 3.7 a 4.2 GHz.

Cada satélite cuenta con 12 ó 24 transponders, dependiendo del tipo . El ancho de banda de cada transponder para Tv es de 36 MHz, pero no contando las guardabandas, se puede considerar de 30 MHz. El audio se envía generalmente en una subportada modulada en frecuencia de 6.2 ó 6.8 MHz. Los satélites que cuentan con 24 canales de TV emplean el sistema de reuso de frecuencias, enviando 12 canales con polarización horizontal y 12 con polarización vertical. La polarización es relativa al polo norte de la tierra o al ángulo oblicuo de la antena del satélite y no a la de la ubicación de la estación terrena.

Las estaciones terrenas que proporcionan la facilidad de recibir únicamente TV son relativamente simples. Las fig 23 y 24 muestran diagramas a bloques en los cuales se representan los principales circuitos que los componen.

604 97

Los circuitos fundamentales para este tipo de estación son:

- 1.- Antena
- 2.- Amplificador de bajo nivel de ruido (LNA)
- 3.- Conversor
- 4.- Receptor de TV
- 5.- Monitor

Como puede observar en la fig. 23 (a), el equipo de la estación, se ha dividido en dos partes, indicadas mediante líneas punteadas; una parte representa lo que llamaremos el equipo externo y la otra el equipo interno.

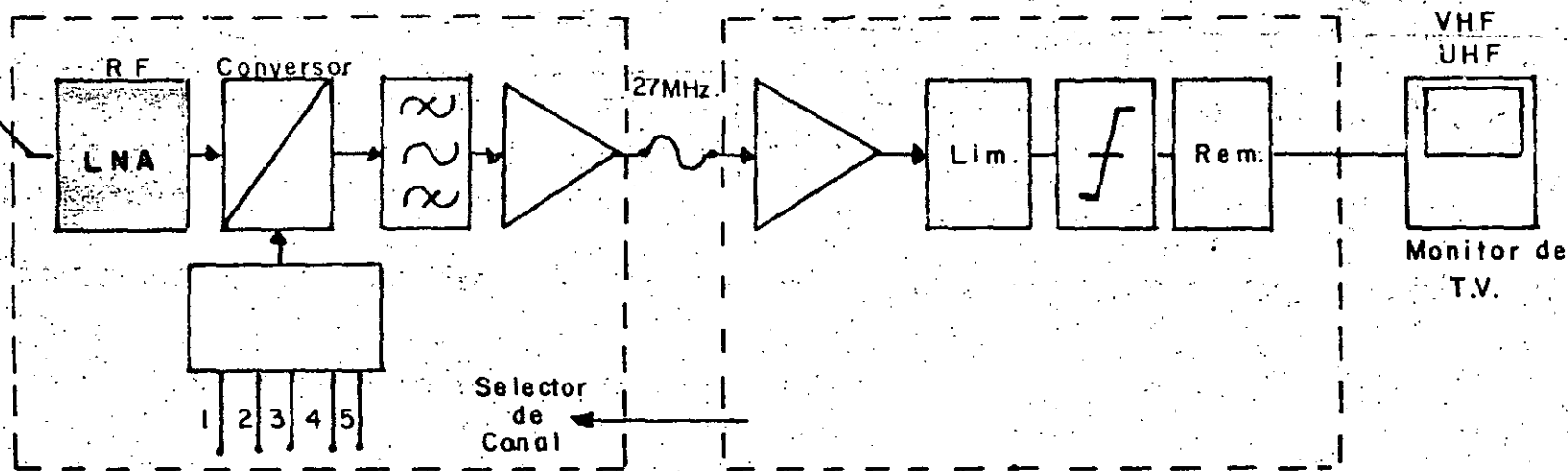
El equipo externo representa a aquellos circuitos que se encuentran al intemperie, y el equipo interno a aquellos circuitos que colocamos dentro de un local cubierto.

Existen dos tipos de estaciones, dependiendo del número de conversiones de frecuencia que se lleve a cabo hasta recuperar la información de banda base, es decir la señal de TV; de una sola conversión o de doble conversión.

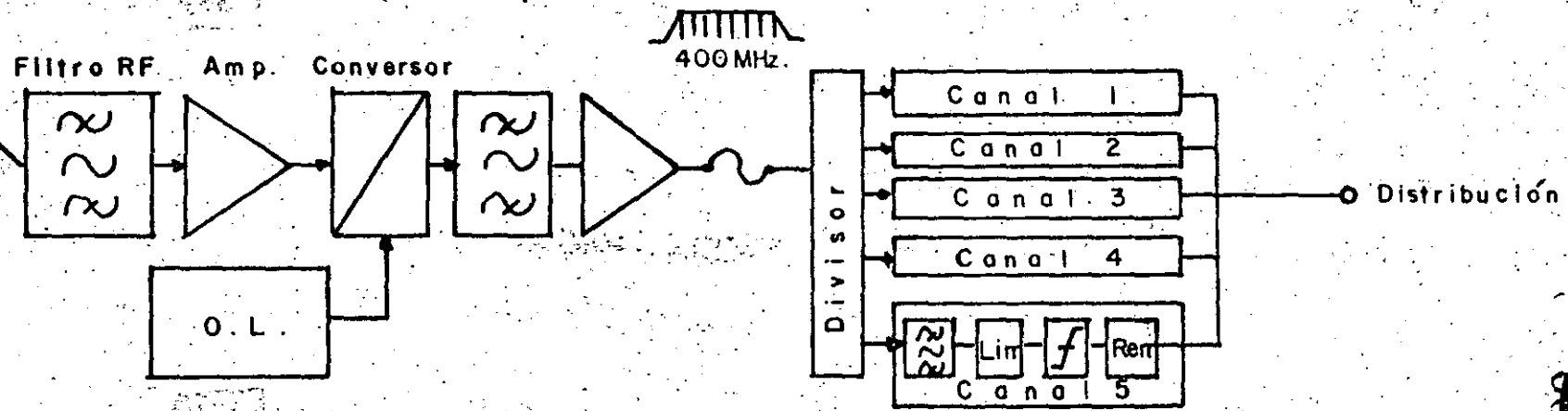
La fig. 23 representa dos posibilidades de estaciones terrenas de pequeña capacidad; en (a) se observa una estación terrena para un solo usuario y en (b) una estación terrena para varios usuarios, empleando ambos una sola conversión de frecuencia.

En la fig. 23 (a) el equipo externo lo forman el LNA, el conversor de frecuencia, un oscilador que estará regido desde el local del equipo interno, un filtro pasabanda centrado a la FI y un amplificador de FI. En esta primera etapa, se ha realizado una sola conversión de frecuencia, es decir se ha trasladado la información que venía en RF, a una frecuencia menor de FI, que generalmente es de 30 MHz .

Esta señal de FI modulada en frecuencia se envía mediante un cable coaxial de bajas pérdidas hacia el receptor de TV, que se



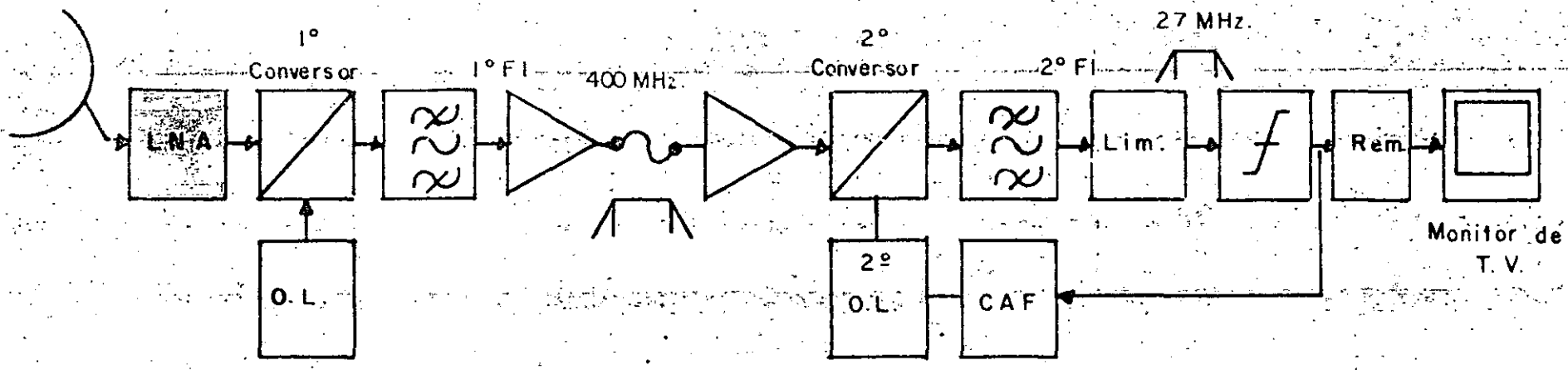
a) Estación terrena para un solo abonado con una sola conversión de frecuencia



b)

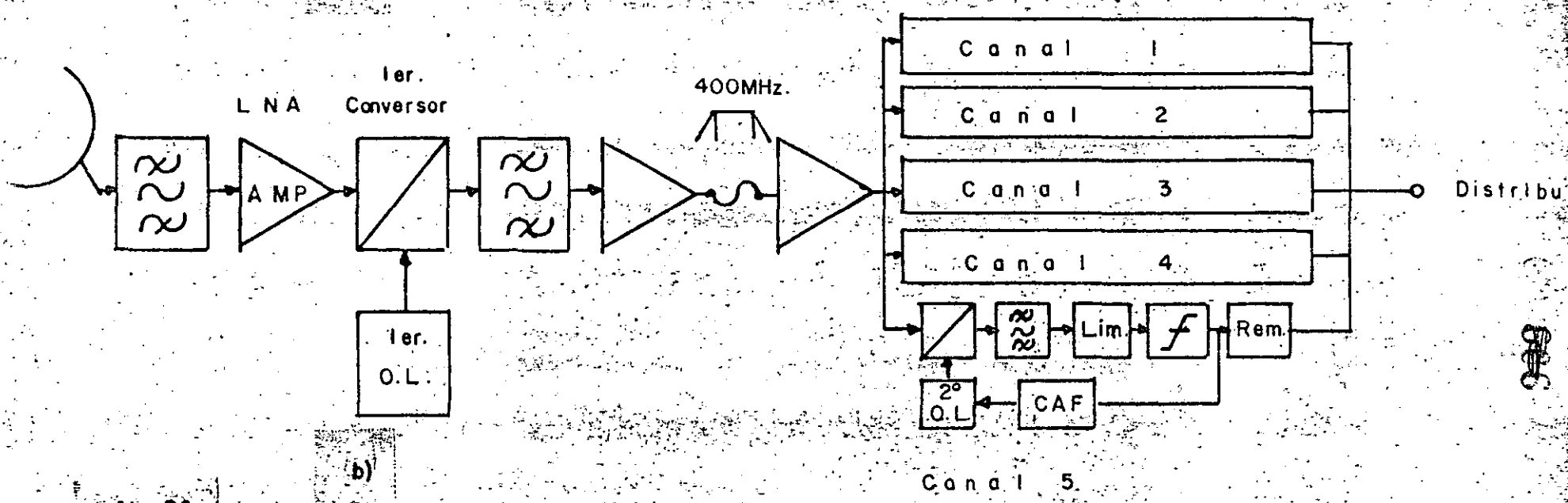
Fig. 23

Estación terrena para varios usuarios con una sola conversión de frecuencia



Estación terrena para un solo usuario con doble conversión de frecuencia.

a)



b)

Fig. 24

Estación terrena para varios usuarios con doble conversión de frecuencia.

encuentra en un local protegido, en donde se realizan ⁶⁰⁷procesamiento 100
to de la información, es decir, se amplifica, ^{pasas} por un circuito limi-
tador, un discriminador y posteriormente se aplica a un monitor de
TV, o se puede modular sobre una portadora que se seleccione, ya
sea en la banda de VHF o UHF, para después aplicarse a la entrada 534
de un receptor de televisión a color comercial, que sintonice la
frecuencia seleccionada.

En la fig. 23 (b) se ilustra un diagrama a bloques de una
posibilidad para una estación terrena de pequeña capacidad emplea-
da para varios usuarios y con una sola conversión de frecuencia.

El circuito exterior está formado por un filtro pasabanda de
Radio Frecuencia con un ancho de banda de 500 MHz aproximadamente,
un amplificador de bajo nivel de ruido, un conversor, un oscilador
local que al mezclarse con la señal de R. F. en el conversor, pro-
duce una señal de Frecuencia Intermedia, cuyo ancho de banda será
de los 500 MHz, es decir, contiene la información de los 12 canales
de televisión. Esta señal se envía al equipo interior una vez que
ha pasado a través de un filtro pasabanda y un amplificador. En el
equipo interior existe un divisor ó filtro de ramificación, el cual
proporciona una trayectoria para cada canal. Una vez seleccionado
un canal determinado, éste se filtra, se limita, se discrimina y se
puede modular en la banda de VHF ó UHF ó se puede alimentar a un
monitor de televisión cromática.

En la fig. (24a) se representa una estación terrena con doble
conversión.

En el circuito externo se lleva a cabo una primera conversión
de frecuencia, bajando la señal hacia el equipo interno en una fre-
cuencia intermedia (que puede ser 1200 MHz) con un ancho de banda
de 500 MHz. En el receptor se lleva a cabo una segunda conversión
de frecuencia (70 MHz), la cual tiene un ancho de banda de 30 MHz,
debido a que se seleccionó un canal de TV deseado. Esta señal se

limita, se discrimina, se remodula ó se aplica a un monitor de TV. 101

En la fig. (24b) se representa el diagrama a bloques de una estación terrena para varios usuarios con una doble conversión de frecuencia. En esta estación, la primera conversión de frecuencia se lleva a cabo en el circuito externo, la frecuencia intermedia también en este caso tiene un ancho de banda de 500 MHz. Esta señal al llegar al equipo interior se ramifica en el número de canales de televisión recibidos. La segunda conversión de frecuencia se lleva a cabo en los circuitos que manejan un solo canal de televisión seleccionado, continuando con el procesamiento de limitación, discriminación, y remodulación de la información para entregarse a los usuarios.

Hay otro tipo de estación terrena en la cual el equipo externo únicamente amplifica la señal de Radio Frecuencia, entregándola al equipo receptor en donde se lleva a cabo la conversión de frecuencia a una FI de 70 MHz. El oscilador local selecciona al canal de televisión deseado. Este oscilador es generalmente un circuito sintetizado. La FI se amplifica, limita, discrimina y se remodula ó se entrega a un monitor de televisión.

14 SELECCION DE LAS DIMENSIONES DE LA ANTENA PARABOLICA

Es de interés poder determinar el diámetro de la antena parabólica que se requerirá en una estación terrena para poder recibir con buena calidad la señal que proviene de un satélite seleccionado. Debe de preverse que la irregularidad de la superficie reflectora de la parábola no debe exceder $1/24 \lambda$ (0.3175 cm. para la frecuencia de 4 GHz.)

La sensibilidad del receptor deber ser del orden de - 50 a - 80 dbm con una figura de ruido de 10 a 15 db.

Una razón del nivel de portadora recibida (C/N) de al menos 10 db dará una buena calidad de imagen una vez que se exceda el umbral de F.M. del receptor. Se puede tomar como regla general que la mayoría de los receptores necesitan una (C/N) de aproximadamente 10 db.

Lo que se requiere conocer realmente es el nivel de la señal del satélite en nuestra localización y el nivel de ruido. Si sumamos 10 db a la diferencia, se obtendrá la ganancia de la antena requerida.

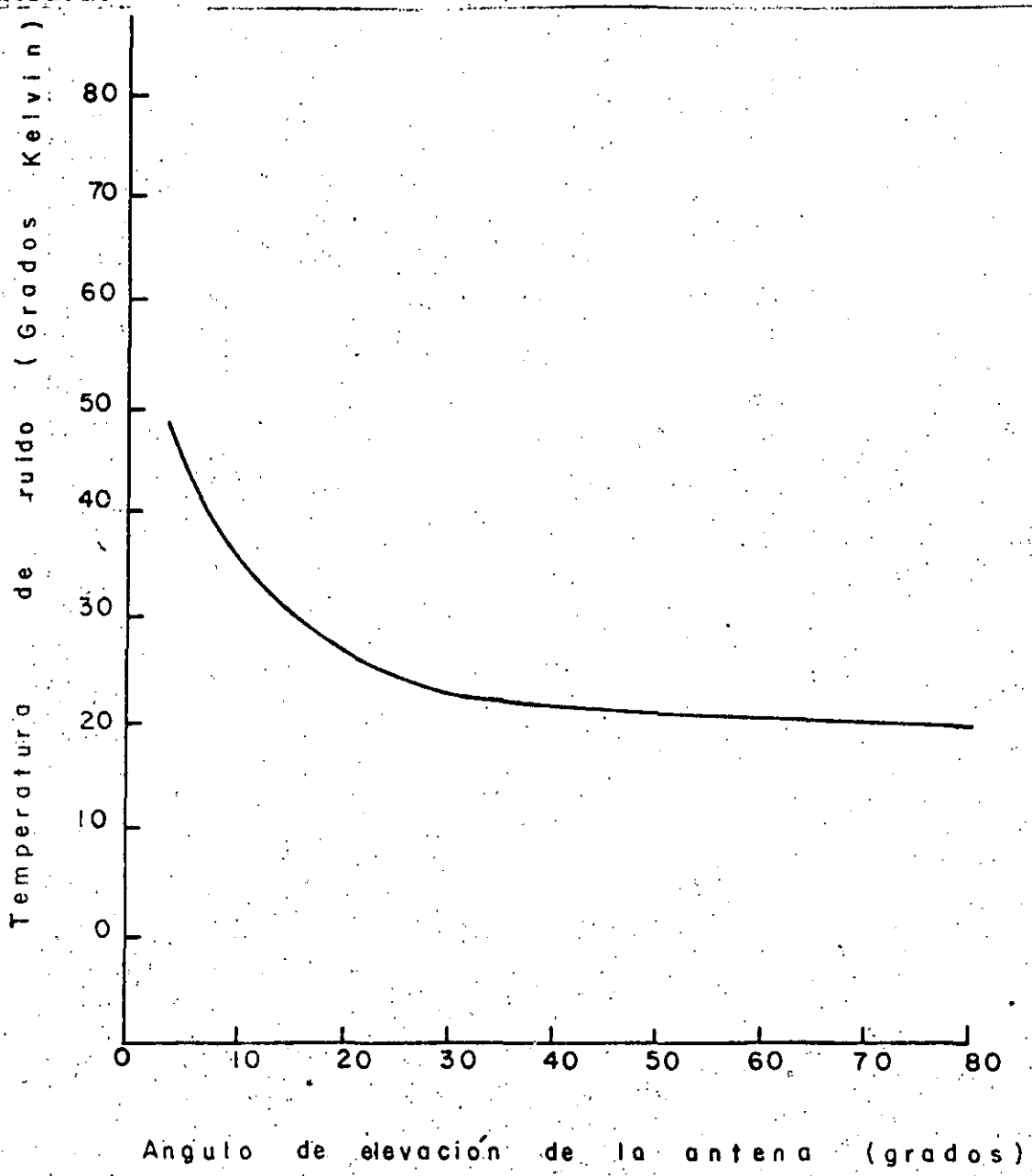


Fig. 25 Temperatura de ruido de una antena parabólica en función del ángulo de elevación.

Tabla 16

Figura de Ruido	Temperatura de Ruido
3.0 db	290° K
2.5 db	225° K
2.0 db	170° K
1.5 db	120° K
1.3 db	100° K
1.0 db	75° K

537

La tabla (16) representa la equivalencia de figura de ruido a la temperatura de ruido de un LNA.

Se debe conocer la temperatura de ruido del sistema, esto es una mezcla de ruido de la antena, del LNA y el ruido del receptor. Puesto que se debe exceder el umbral de ruido del receptor por lo menos en 10 db, se puede ignorar la temperatura de ruido del receptor y tratar únicamente con el ruido de la antena y del LNA, la fig. (25) muestra una gráfica de la temperatura de ruido típica de una antena parabólica en función del ángulo de elevación. Observe que el ruido disminuye cuando la antena se dirige hacia el Cenit.

La tabla 16 representa una lista de las temperaturas de ruido de los LNA típicos que se encuentran en el mercado, considerándose 100° como un muy buen LNA.

Si se suman las temperaturas de ruido del LNA y el ruido interceptado por la antena, se tendrá una idea clara de la temperatura de ruido del sistema.

Por ejemplo una antena que se orienta a 47.171° de elevación, intercepta aproximadamente 20° K de ruido (ver fig. 25).

Si se selecciona un LNA de 100° , al sumarlos con la temperatura de ruido de la antena, tendremos una temperatura de ruido del sistema de 120° .

De la ecuación (3) se tiene que:

$$\text{Pot. de Ruido } P_N = K T W$$

Sustituyendo valores

$$P_N = 1.38 \times 10^{-23} \times 120^\circ \times 30 \times 10^6$$

$$= 49 \times 10^{-15}$$

Expresado en dbw

$$P_{N \text{ dbw}} = 10 \log (49 \times 10^{-15})$$

$$= -133$$

La señal que proviene del satélite SATCOM F₁ tiene un nivel de aproximadamente -165 dbw lo cual como puede observarse es más pequeña que el nivel del ruido (-133 dbw). Si sumamos ahora la ganancia de una antena receptora digamos de 45 db, la señal que se recibe sobre pasará al nivel del ruido.

Esto es:

$$-165 \text{ dbw} + 45 \text{ db} = -120 \text{ dbw}$$

La razón señal a ruido del sistema (C/N) sera:

$$C/N = -120 \text{ dbw} - (-133) \text{ dbw}$$

$$C/N = 13 \text{ dbw}$$

lo cual quiere decir que la señal que proviene del satélite excede en 13 db al nivel del ruido, proporcionando una imagen de buena calidad.

Para encontrar la ganancia de la antena y sus dimensiones físicas que se requieran en un punto de interés particular, simplemente se puede aplicar la siguiente consideración.

$$G_a = P_N - C + C/N \quad (19)$$

donde:

$$G_a = \text{Ganancia de la antena}$$

P_N = Nivel de ruido

C/N = Razón señal a ruido del sistema

C = Nivel de la señal que proviene del satélite.

De acuerdo al ejemplo anterior se tiene que la ganancia requerida por la antena en el punto de recepción es de:

$$G_a = -133 \text{ dbw} - (-165) \text{ dbw} + 13 \text{ db}$$

$$G_a = 45 \text{ db}$$

Observando la fig. (20) de la sección de cálculo de enlace digital, se determina que el diámetro requerido por la antena parabólica es de 6 m. junto con una LNA de 100° K .

La fig. (26) muestra un mapa de contornos del EIRP del satélite SATCOM-I-F₁

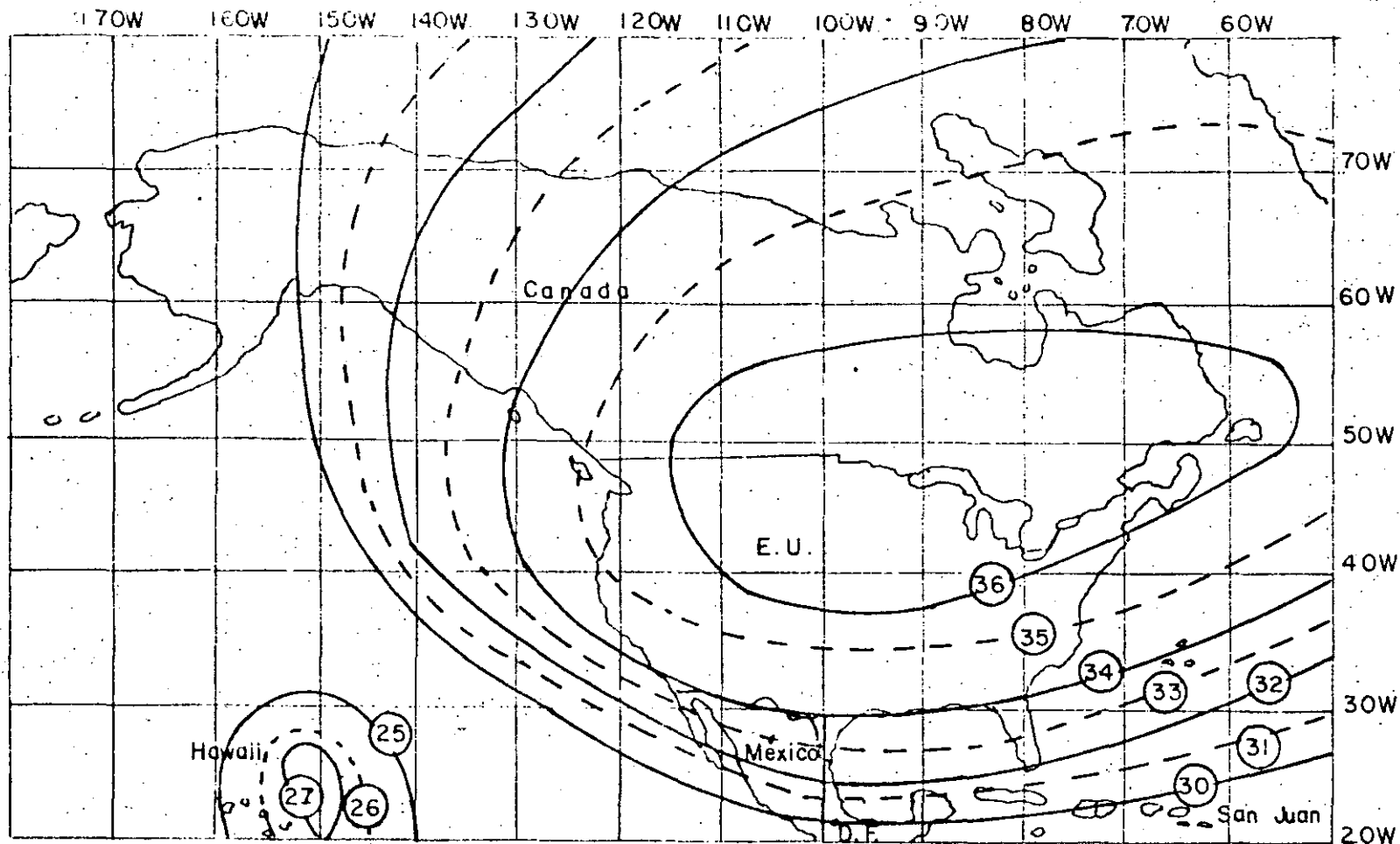


Fig. 26 Mapa de contornos de la EIRP en dBW
 Satellite. SATCOM I (F1)
 Transponders. 2, 6, 10, 14, 18, 22.
 Polarización. Horizontal
 Formato de canal. Video CATV
 Uso. Repetidora de programación CATV

4.1 DISTORSION POR INTERMODULACION EN SISTEMAS DE FM CON PORTADORAS MULTIPLES

En un capítulo anterior se ha estudiado el problema del ruido de intermodulación en un sistema de microondas ---- FDM/FM que resulta de varias no-linealidades con respecto a la frecuencia de la trayectoria de radio transmisión. Las perturbaciones resultantes dan lugar a la distorsión de la señal multicanal, la cual aparece en cada canal telefónico como un ruido ya sea ininteligible o como diafonía (ruido inteligible), - la cual consiste en la reproducción del contenido de otro canal.

Un mecanismo adicional de distorsión es proporcionado por la detección de la portadora modulada deseada, junto -- con otra portadora la cual puede estar modulada o no modulada. En sistemas de radiodifusión de un solo canal, la portadora -- interferente generalmente proviene de otra estación, pero en -- sistemas multicanales, la portadora interferente puede originarse en otro sistema o dentro del mismo sistema el cual se -- emplea para transmitir simultáneamente un cierto número de portadoras de RF. (Sistema con portadoras múltiples moduladas en frecuencia), cada una de ellas moduladas con un gran número de canales de voz.

Los sistemas de FM multiportadora que emplean un -- amplificador de potencia común de banda ancha, son de gran -- importancia en los enlaces de microondas y particularmente en

la comunicación simultánea mediante satélites entre varios pares de estaciones terrenas. Dicho sistema multiplex en RF se obtiene, asignando una ranura de frecuencia a cada portadora modulada dentro del pasabanda del amplificador común.

En sistemas de FM multiportadora, se encuentran varias fuentes de distorsión por intermodulación. Como en el caso de sistemas de FM de una sola portadora, es necesario considerar el ruido de intermodulación producido directamente por las desviaciones de la transmisión dentro de la banda transmitida, o sean, las desviaciones en las características de ganancia y fase de las características ideales de ganancia constante y fase lineal para todas las componentes de frecuencia de la onda modulada en frecuencia. Además, la distorsión por intermodulación es propia de la amplificación no lineal de las fluctuaciones de la envolvente de la onda combinada.

Por otra parte, como en los sistemas de FM de una sola portadora, los términos de distorsión de envolvente no producen directamente efectos de degradación en los sistemas lineales. Sin embargo, cuando el medio de transmisión lineal es seguido por un dispositivo que convierte las variaciones de envolvente que están presentes en la entrada, a variaciones de fase en su salida, entonces la señal a la salida del conversor contendrá una función de distorsión adicional modulando en fase, denominada ruido de intermodulación AM/PM.

Este tipo de ruido de intermodulación se encuentra generalmente en transmisores de microondas a tubos de onda -- progresiva (TOP) y Klystrons. Estos dispositivos se caracterizan por el mecanismo de conversión AM/PM, al cual está asociada una constante K que tiene las unidades de grado/decibel.

La constante K puede interpretarse como el cambio de fase pico a la salida para una carga de la envolvente a la entrada de 1 db.

Otro deterioro que puede encontrarse en la transmisión de sistemas de FM multiportadora es la diafonía entre canales de voz de diferentes grupos de portadoras. Dicha diafonía es originada por la distorsión atenuación-frecuencia (atenuación en función de la frecuencia) que resulta de la conversión AM/PM y disminuye cuando se incrementa el número de grupos de portadora. Por el contrario, la distorsión intermodulación origina un ruido semejante al de interferencia y se incrementa cuando se aumenta el número de portadoras.

Los tipos de ruido que están presentes en los sistemas multiplex de RF son:

- 1) El ruido de intermodulación debido a las desviaciones de la transmisión y
- 2) El ruido de intermodulación debido a las desviaciones de transmisión y a la conversión AM/PM.

El valor de $\omega_D = 2\pi f_D = 2\pi (2.48 \times 10^6)$ en donde $f_D = 2.48 \times 10^6$ Hz = a la separación entre frecuencias de portadoras deseada y no deseada.

4.7 PORTADORA ADICIONAL MODULADA

Si la modulación de una portadora no deseada ocupa la misma gama de frecuencias que la banda base, produciendo la misma desviación rms que la de la portadora deseada, no obstante ésto, las modulaciones no estarán relacionadas.

La resultante de las portadoras deseada y no deseada es:

$$e_r(t) = \cos(\omega_c t + \mu_t) + r \cos\left[(\omega_c + \omega_D)t + V_t\right] \quad (4.13)$$

donde

$$A^2 = 1 + r^2 + 2r \cos(\omega_D t + V_t - \mu_t) \quad (4.14)$$

$$\mu_d = \tan^{-1} \left(\frac{r \sin(\omega_D t + V_t - \mu_t)}{1 + r \cos(\omega_D t + V_t - \mu_t)} \right) \quad (4.15)$$

μ_t y V_t son modulaciones en fase de las portadoras deseada y no deseada respectivamente.

Cuando $r \ll 1$, se tiene que

$$A \approx 1 + r \cos(\omega_D t + V_t - \mu_t) \quad (4.16)$$

y

$$\mu_d = r \text{ sen } (\omega_D t + V_t - \mu_t) \tag{4.17}$$

Dado que V_t y μ_t no están relacionadas una con la otra, $V_t - \mu_t$ puede considerarse como una banda de ruido que ocupan la misma gama de frecuencias que V_t o μ_t pero que tienen una amplitud rms incrementada por $\sqrt{2}$ (adición de potencia). Así, la distorsión no lineal que aparece como diafonía ininteligible puede calcularse mediante la ecuación (4.8), sustituyendo ω_Δ por $\sqrt{2} \omega_\Delta$.

4.8 DISTORSION DEBIDO A UNA PORTADORA ADICIONAL DE GRAN AMPLITUD ($r \leq 1$)

En este caso se hace uso de las expresiones exactas dadas por las ecuaciones (4.2) y (4.3), que describen la modulación de amplitud instantánea y la modulación de fase adicional de la onda resultante. Se considerará únicamente el caso no modulado.

Suponiendo que se emplea un limitador perfecto, la distorsión de modulación de fase μ_d dada por la ecuación (4.3) puede expresarse como una expansión de Fourier que toma la siguiente forma:

$$\begin{aligned} \mu_d = & r \text{ sen } (\omega_D t - \mu_t) - \frac{r^2}{2} \text{ sen } 2 (\omega_D t - \mu_t) \\ & + \frac{r^3}{3} \text{ sen } 3 (\omega_D t - \mu_t) + \dots \dots \dots \end{aligned} \tag{4.18}$$

La contribución del primer término ya se ha considerado en el párrafo correspondiente a "portadora adicional no modulada". La contribución de los términos restantes a la razón de distorsión/potencia de señal a la frecuencia de banda base ω_m , está dada aproximadamente por

$$\frac{\omega_m^2 (\hat{\omega}_m - \check{\omega}_m)}{\sqrt{2\pi} \omega_\Delta^3} \sum_{n=2}^{\infty} \frac{r^{2n}}{n^3} \exp\left(-\frac{\omega_D^2 + \omega_m^2/n^2}{2\omega_\Delta^2}\right) \cos h \frac{\omega_\Delta \omega_m}{n\omega_\Delta^2} \quad (4.19)$$

Resultados numéricos para un sistema de 600 canales, muestran que la contribución de distorsión calculada empleando la ecuación (4.19) es considerablemente menor que lo que resulta al emplear el primer término de la ecuación (4.18) o la ecuación (4.8). Así, considerando que se cumplen las condiciones del receptor, el nivel de distorsión variará linealmente con el nivel de la portadora adicional hasta la condición de igual portadora adicional ($r = 1$). Sin embargo, la linealidad entre la distorsión y la portadora adicional no serán válidos en el caso de un limitador imperfecto y $r \neq 1$.

4.9 RESULTADOS PARA SISTEMAS DE 240 Y 600 CANALES

Se suponen los siguientes parámetros:

Número de canales	Limites de la banda - base MHz	Nivel de potencia multicanal) dbm0	Desviación rms por canal KHz	Desviación rms total MHz
240	0.06-1.052	12.2	200	0.812
600	0.06-2.540	14.8	200	1.100

1) Relativo a un miliwatt en un punto de nivel relativo cero.

La desviación rms total, se toma convencionalmente - como la desviación debido a los canales de conversación, tonos de prueba, etc., la cual es excedida por no más del 1% de la hora más ocupada.

Las figuras (4.1) y (4.2) muestran la variación de distorsión teórica para tres frecuencias de banda base, en función de la separación de portadoras, con portadoras interferentes moduladas y no moduladas para sistemas de 240 y 600 canales. Se supone que las características del limitador son suficientes para asegurar la validez de la ecuación (4.8). Bajo estas condiciones, la distorsión será linealmente proporcional al nivel de portadora adicional hasta $r = 1$. En todos los casos la distorsión mostrada consiste de diafonía ininteligible.

Las figuras (4.3) y (4.4) muestran las variaciones de distorsión medidas con un nivel de portadora interferente para un sistema de 600 canales. La señal moduladora fue una banda de ruido plano simulando una señal de banda base FDM de 600 canales. En la figura (4.3) se muestra la distorsión en función del nivel de portadora interferente y una separación de cero Hz de la frecuencia de portadora.

Obsérvese que cuando el nivel de la portadora adicional se aproxima al nivel de la portadora deseada, existe una divergencia de linealidad. En la figura (4.4) se presenta la

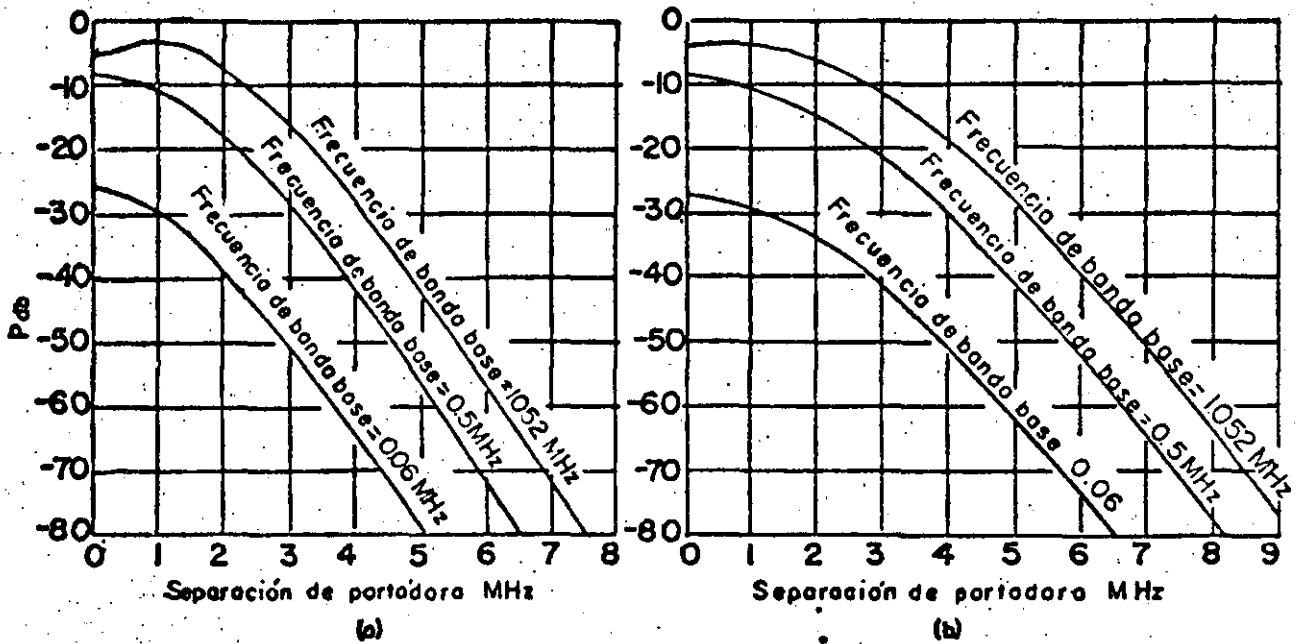


Fig. (4.1) Distorsión debido a una portadora interferente en un sistema de 240 canales telefónicos con un limitador ideal. La razón distorsión/señal es $P + 20 \log_{10} r$ dB. (a) Portadora sin modular (b) Portadora modulada

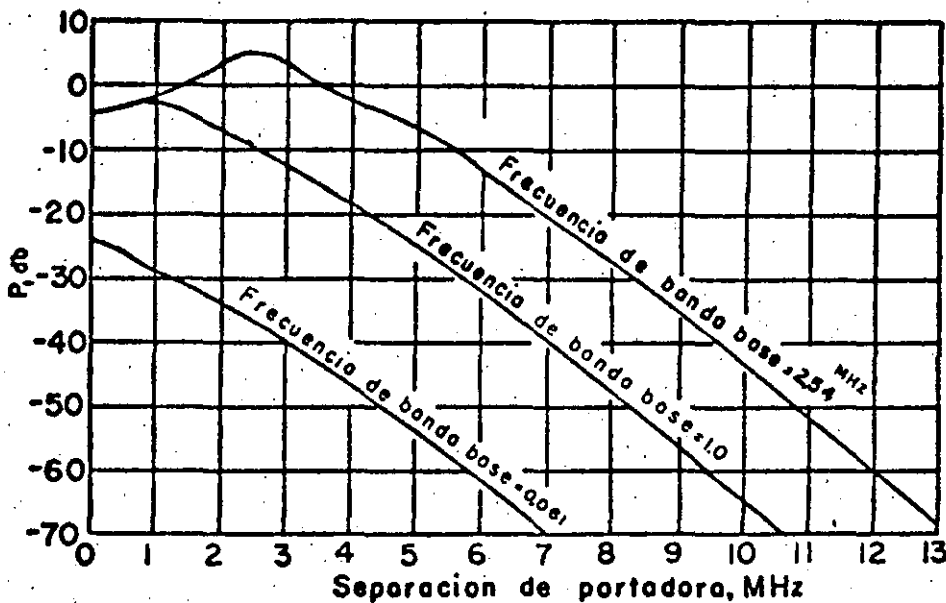
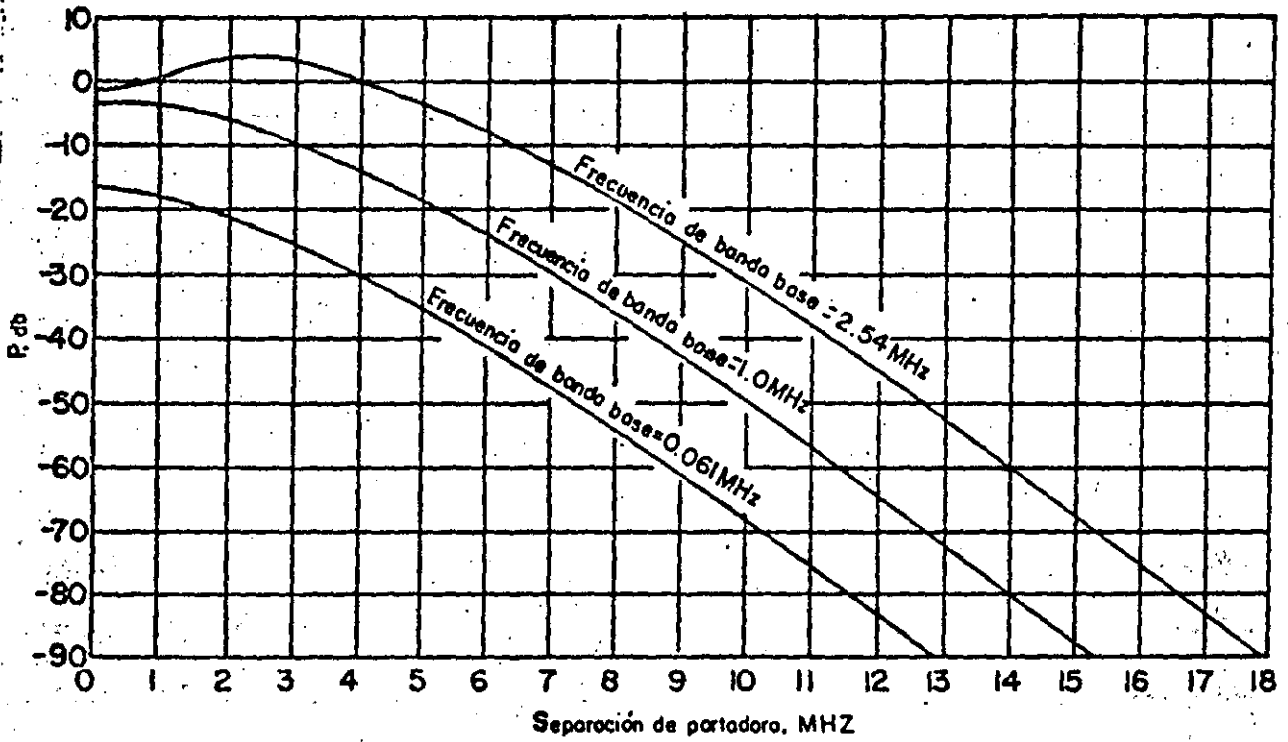


Fig. (4.2) Distorsión debido a una portadora interferente en un sistema de 600 canales telefónicos con un limitador ideal. La razón distorsión/señal es $P + 20 \log_{10} r$ dB. (a) Portadora sin modular (b) Portadora modulada



(b)

distorsión en función de la separación de la frecuencia portadora. Cuando la separación de frecuencia no es muy grande, -- los resultados teóricos y prácticos coinciden.

4.10 DISTORSION EN SISTEMAS FDM/FM DEBIDO A MULTIPLES PORTADORAS INTERFERENTES.

En esta sección se generalizará el análisis de distorsión por portadora interferente a un sistema que contiene un gran número de portadoras, cada una modulada por una señal de banda base formada por una gran cantidad de canales de conversación. Actualmente existen en operación sistemas de 960 y 1800 canales, por lo que se presentarán curvas de distorsión para los sistemas de 1800 canales.

Los requisitos de ancho de banda y niveles de distorsión debido a la interferencia por portadoras no deseadas, -- dependen de la forma y gama del espectro de RF de la portadora modulada deseada. En el caso de FDM/FM, el espectro de RF -- varía de una forma muy complicada, debido a los cambios de las características de conversación individuales y a las variaciones en el número instantáneo de usuarios. Como se indicó anteriormente, la señal FDM puede simularse por medio de una banda de ruido blanco que cubra el mismo espectro de frecuencias que la banda base y que tenga una amplitud rms igual a la media de los niveles rms instantáneos de la señal FDM (tomada en la -- hora de mayor tráfico telefónico).

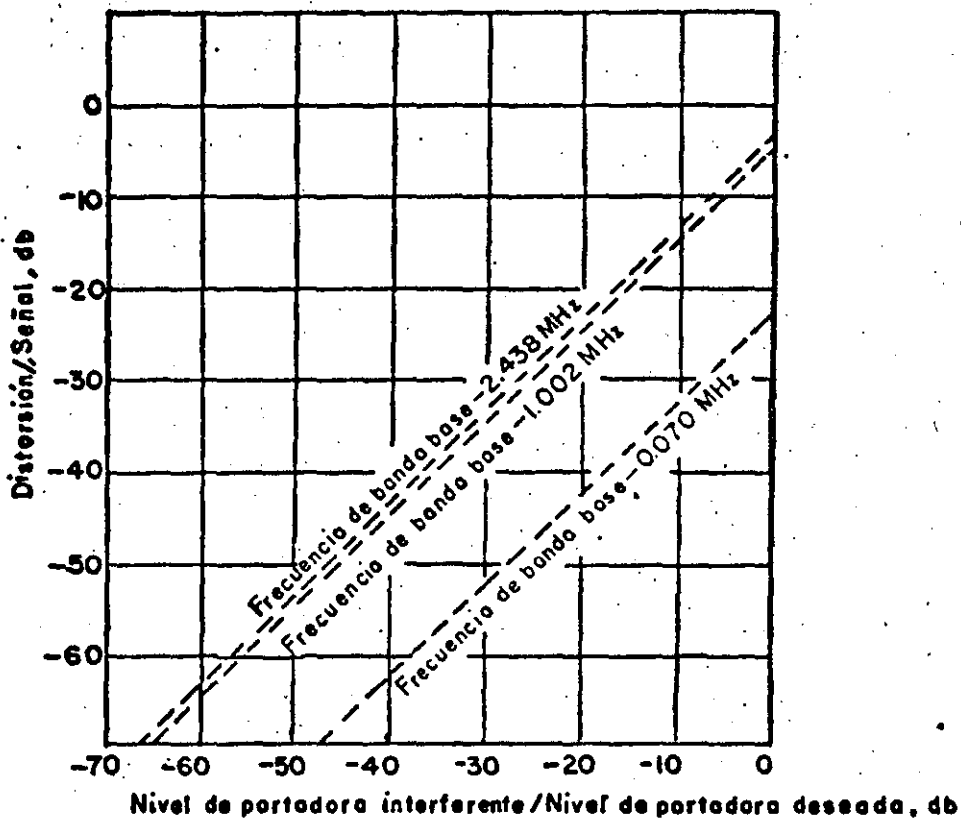


Fig. (4.3) Variación del nivel de distorsión medido con un nivel de portadora interferente para un sistema de 600 canales. La separación frecuencia de la portadora es de 0 Hz. La portadora interferente está sin modular.

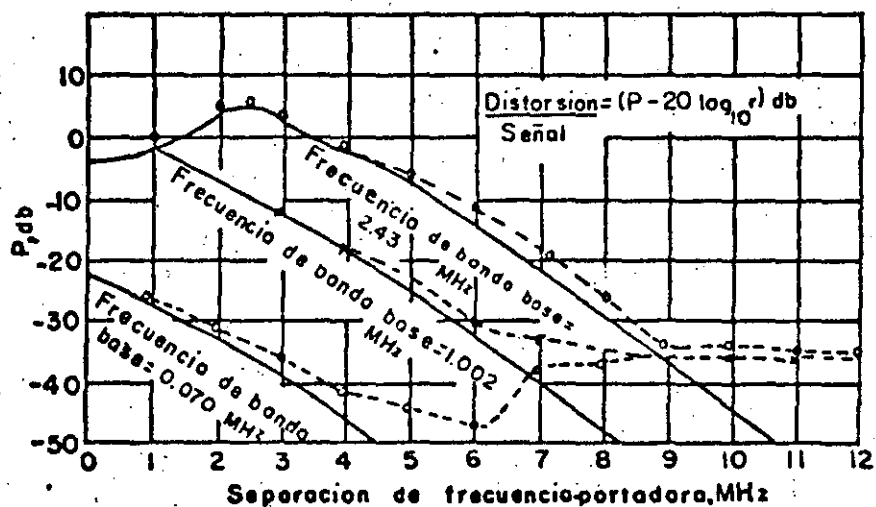


Fig. (4.4) Variación del nivel de distorsión medido con una separación de la frecuencia portadora para un sistema de 600 canales. El nivel de la portadora interferente sin modular es mucho menor que el nivel de la portadora deseada.

La banda de ruido blanco que simula a una señal FDM, tiene las siguientes características:

$\tilde{\omega}_m = P_o$ = Mínima frecuencia modulante, rad/seg.

$\hat{\omega}_m = P_m$ = Máxima frecuencia modulante, rad/seg.

ω_Δ = Desviación de frecuencia rms rad/seg.

Los valores de estos parámetros para varios canales telefónicos y diversas condiciones de modulación, se presentan en la tabla 1.

Como se indicó anteriormente, una función importante de esas cantidades que describen la distribución espectral de la portadora de RF modulada es la expresión $\omega_\Delta^2 / P_o P_m$. Cuando la cantidad $\omega_\Delta^2 / P_o P_m \gg 1$, la gráfica de la potencia espectral de RF en función de la frecuencia, toma la forma de una curva plana y continua. Esta condición se mantiene para cualquier número de canales, hasta 960, con valores óptimos de desviación de frecuencia rms.

Cuando $\omega_\Delta^2 / P_o P_m < 1$, el espectro se divide en secciones discontinuas y aparece un tono en la frecuencia portadora que contiene una gran parte de la potencia total. Esta condición se aplica a sistemas de 1800 canales o más.

En seguida se analizará el espectro de RF de un sistema de 1800 canales y se presentarán curvas que muestran la distorsión de portadora interferente. A partir de esos resultados, se determinarán las separaciones permitidas de portadoras para los sistemas multicanales de RF con el propósito de que cumplan los requisitos de distorsión.

4.11 FORMULA PARA DETERMINAR EL ESPECTRO DE RF (INCLUYENDO TERMINOS DE TERCER ORDEN)

La portadora modulada se considera que tiene una potencia unitaria y se puede representar de la siguiente forma:

$$\sqrt{2} \cos (\omega_c t + \mu_t) = \sqrt{2} \cos \omega_c t \cos \mu_t - \sqrt{2} \sin \omega_c t \sin \mu_t \quad (4.20)$$

Donde μ_t indica la modulación de fase de la señal. - La banda de ruido blanco puede representarse por la expresión

$$\phi(t) = \frac{\sqrt{2} \omega_\Delta}{P_m - P_o} \sum_{p=p_o}^{P_m} \cos (Pt + \phi_p) \quad (4.21)$$

Donde P se incrementa en pasos unitarios y ϕ_p es un ángulo de fase aleatorio uniformemente distribuido en la gama de 0 a 2π . La modulación de fase correspondiente es por lo tanto.

$$\mu_t = \int \phi(t) dt = \frac{\sqrt{2} \omega_\Delta}{\sqrt{P_m - P_o}} \sum_{p=p_o}^{P_m} \frac{1}{p} \sin (Pt + \phi_p) \quad (4.22)$$

TABLA (IV.1) Condiciones de modulación para varios canales telefónicos

Número de canales	Banda base ($\frac{1}{2\pi} \omega_m$ a $\frac{1}{2\pi} \hat{\omega}_m$) KHz	Desviación rms por canal KHz	Fórmula para nivel rms de banda de rui- do equivalen- te	Desviación rms de la banda de ruido equiva- lente ($\frac{1}{2\pi} \omega_\Delta$) KHz	$\frac{\omega_\Delta}{\hat{\omega}_m}$	$\frac{\sqrt{\omega_m}}{\hat{\omega}_m}$	$\frac{\omega_\Delta^2}{\omega_m \hat{\omega}_m}$
6	12 - 36	20	A	26	0.71	0.33	1.5
6	12 - 36	50	A	64	1.77	0.33	9.4
12	12 - 60	20	A	30	0.50	0.20	1.3
12	12 - 60	50	A	75	1.25	0.20	7.8
12	6 - 54	20	A	30	0.56	0.11	2.8
12	6 - 54	50	A	75	1.39	0.11	17.4
24	12 - 108	35	A	59	0.55	0.11	2.7
24	12 - 108	50	A	84	0.78	0.11	5.5
36	12 - 156	35	A	64	0.41	0.08	2.2
36	12 - 156	50	A	91	0.59	0.08	4.5
36	12 - 156	100	A	183	1.17	0.08	17.8
60	60 - 300	50	A	101	0.34	0.20	0.6
60	60 - 300	100	A	202	0.67	0.20	2.3
60	60 - 300	200	A	404	1.35	0.20	9.1
120	60 - 552	50	A	116	0.21	0.11	0.4
120	60 - 552	100	A	232	0.42	0.11	1.6
120	60 - 552	200	A	464	0.84	0.11	6.5
240	60 - 1052	200	B	551	0.52	0.05	4.8
300	60 - 1300	200	B	616	0.47	0.05	4.9
600	60 - 2540	200	B	871	0.34	0.02	5.0
960	60 - 4028	200	B	1102	0.27	0.01	5.0
960	316 - 4188	200	B	1102	0.26	0.01	0.9
1800	316 - 8204	140	B	1056	0.13	0.04	0.4
2700	316 - 12388	140	B	1292	0.10	0.03	0.4

Fórmulas para nivel rms de banda de ruido equivalente:

A = (- 4 log₁₀N) dbmO B = (- 15 + 10 log₁₀N) dbmO, donde N = Número de canales

El valor cuadrático medio de la modulación de fase, está dada por:

$$\bar{\mu}_t^2 = \frac{\omega_\Delta^2}{P_m - P_o} \int_{P_o}^{P_m} \frac{1}{p^2} dp = \frac{\omega_\Delta^2}{P_o P_m} \quad (4.23)$$

Si esta cantidad es mucho menor que la unidad, es -- válido expresar a $\cos \mu_t$ y al $\sin \mu_t$ de la ecuación (4.20) como una serie de potencias en μ_t .

Con esta consideración la ecuación (4.20) puede expresarse de la siguiente manera

$$\sqrt{2} \cos (\omega_c t + \mu_t) = \sqrt{2} \exp \left[- \frac{1}{2} \left(\frac{\omega_\Delta^2}{P_o P_m} \right) \right] \left\{ \cos \omega_c t - \mu_t \sin \omega_c t + \frac{1}{2} \mu_t^2 \cos \omega_c t + \frac{1}{6} \mu_t^3 \sin \omega_c t + \dots \right\} \quad (4.24)$$

Una expresión que nos representa la potencia espectral en una banda angosta con un ancho de banda ω_b , a una frecuencia de $\omega_c \pm \omega$, es de la forma:

$$W(\omega) = \omega_b \exp \left(\frac{-\omega_\Delta^2}{P_o P_m} \right) \left\{ \left[\frac{1}{\omega_b} \right]_{\omega=0} + \left[\frac{1}{2} \frac{\omega_\Delta^2}{(P_m - P_o) \omega^2} \right]_{P_o < \omega < P_m} + \left[\frac{1}{4} \frac{\omega_\Delta^4}{(P_m - P_o)^2} \left\{ F_2(\omega) \right\}^2 \right] + \left[\frac{1}{18} \frac{\omega_\Delta^6}{(P_m - P_o)^3} \left\{ F_3(\omega) \right\}^2 \right] \right\} \quad (4.25)$$

El primer término de la ecuación (4.25) representa la potencia en un solo tono a la frecuencia portadora. Los -- términos restantes representan bandas de ruido adicionales, --

originadas por la primera, segunda y tercera potencia de μ_t .

4.12 RAZON ENTRE LA DISTORSION DE LA PORTADORA INTERFERENTE Y EL ESPECTRO DE RF DE LA PORTADORA MODULADA

Cuando estan presentes tonos de RF modulados o no modulados, que tengan frecuencias iguales o cercanas a la frecuencia de la portadora deseada en la entrada del demodulador, junto con la portadora deseada, se producirá distorsión en la señal de salida demodulada.

Cuando el tono interferente está sin modular, la razón de la potencia de distorsión a la potencia de la señal deseada medida en una banda angosta de igual ancho de banda y centrada a la frecuencia P está dada por.

$$\frac{r^2 P_m P^2}{2\omega_b \omega_\Delta^2} \left[W(\omega + P) + W(|\omega - P|) \right] \quad (4.26)$$

Donde $W(\omega)$ esta dada por la ecuación (4.25) hasta el tercer orden. La ecuación (4.26) proporciona una relación directa entre el espectro de RF de la onda modulada y el efecto distorsionante de una portadora interferente no modulada.

También existirán portadoras interferentes moduladas en un sistema multicanal de RF, o pueden ser generados en sistemas internos. Generalmente, aquellas portadoras generadas de un solo sistema multicanal de RF llevarán diferentes cana-

les de conversación que ocupan la misma banda de frecuencia total y producen la misma desviación de frecuencia rms. Bajo estas condiciones la distorsión puede deducirse sustituyendo $W(\omega)$ de la ecuación (4.26) por la función de potencia espectral generada cuando la desviación rms de la portadora deseada se incrementa por $\sqrt{2}$.

Sustituyendo la ecuación (4.25) en la (4.26), se pueden determinar las componentes de distorsión debido a una portadora interferente. El primer término da lugar a una componente de distorsión de un solo tono audible como un silbido a la frecuencia de banda base ω_D . Su magnitud relativa a la potencia en un solo canal de voz, esta dada por

$$\frac{r^2 P_m P^2}{2 P_s \omega_\Delta^2} \exp \left[- \left(\frac{\omega_\Delta^2}{P_o P_m} \right) \right] \quad (4.27)$$

Donde $P_s = 2\pi (4 \times 10^3)$ rad/seg. ó sea el ancho de banda de un canal de voz.

El segundo término de la ecuación (4.25) tiene un espectro igual al de la señal deseada. Es evidente de la ecuación (4.26) que este término podría dar lugar a una diafonía inteligible cuando ω_Δ tiene un valor adecuado, sin embargo la desviación de la portadora generalmente convierte a esta diafonía en ininteligible.

4.13 ESPECTRO DE RF Y DISTORSION DE PORTADORA INTERFERENTE EN UN SISTEMA DE 1800 CANALES

1.- SIN PREENFASIS.- De acuerdo a la recomendación CCIR, el espectro de una banda de ruido blanco que simula a un sistema de 1800 canales, comprende desde 316 KHz a 8204 KHz. La desviación rms por canal es de 140 KHz y el nivel multicanal está dado por la relación $-15 + 10 \log_{10} 1800$ db's relativos a la potencia en un canal, así que la desviación rms de la banda de ruido equivalente es de 1056 KHz (Ver tabla IV.1).

$\omega_{\Delta}^2 / P_o P_m = 0.430$ así que las fórmulas presentadas para calcular el espectro de RF son aplicables.

La figura (4.5) muestra la mitad superior del espectro simétrico modulado en frecuencia calculado mediante la ecuación (4.25) con una modulación de ruido blanco que simula la señal de 1800 canales. La ordenada corresponde a $W(\omega)P_m/\omega_b$ y la potencia de espiga en $\omega = 0$ representa la potencia de portadora residual (independiente de P_m/ω_b).

A partir de los valores de espectro de RF y la ecuación (4.26), se pueden calcular los efectos de distorsión de la portadora interferente, los cuales como se han indicado anteriormente son proporcionales a la amplitud relativa de la portadora interferente. La razón de la distorsión de portadora interferente no modulada a la amplitud relativa de la porta

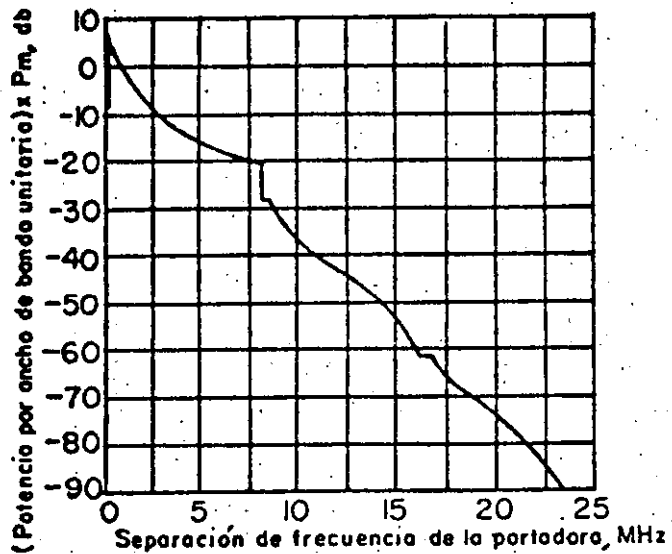


Fig. (4.5) Distribución espectral de una frecuencia de portadora modulada con ruido blanco simulando a un sistema de 1800 canales. Sin preénfasis.

dora interferente, se muestra en la figura (4.6) en función de la separación de las portadoras deseada y no deseada. La figura (4.7) muestra la gráfica correspondiente para una portadora modulada en frecuencia con una banda de ruido similar e independiente.

2.- CON PREENFASIS.- De acuerdo con las recomendaciones del CCIR, la característica de preénfasis para un sistema que transmite hasta 1800 canales está dado por la siguiente -

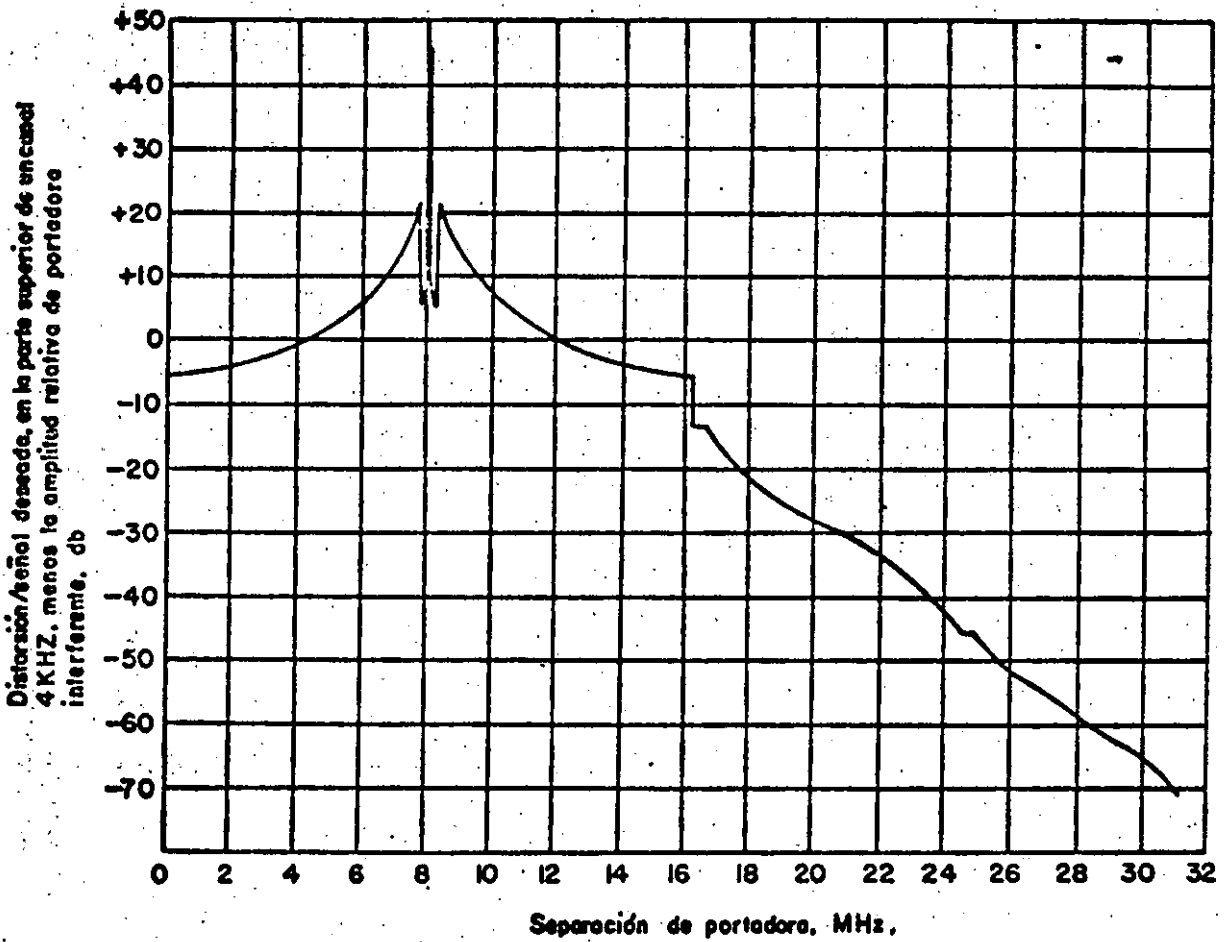


Fig. (4.6) Distorsión debida a una portadora interferente no modulada en un sistema de 1800 canales (se supone una característica de limitación ideal y no se emplea preénfasis).

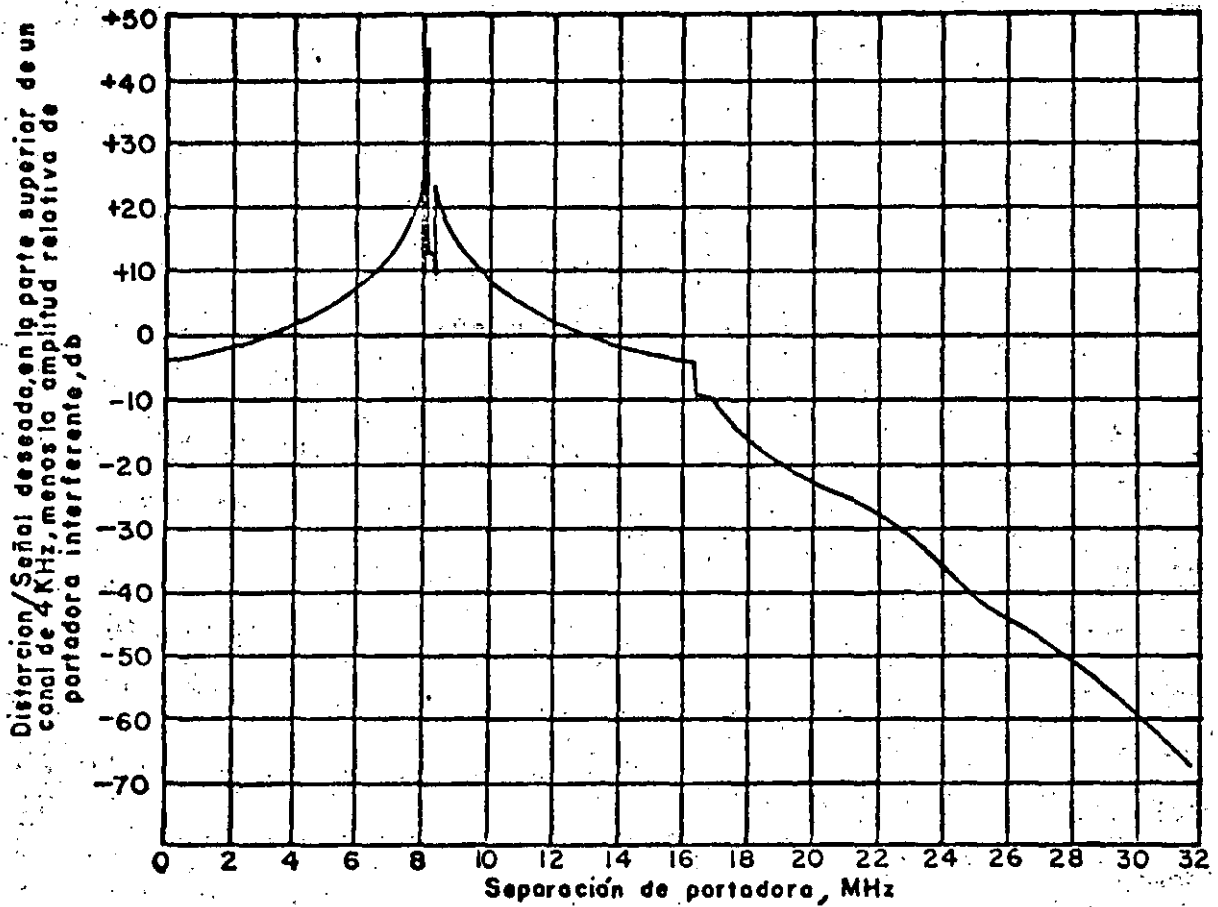


Fig. (4.7) Distorsión debida a una portadora interferente modulada en un sistema de 1800 canales (se -- supone una característica de limitación ideal y no se emplea preénfasis)

función de transferencia.

$$\frac{3.15}{1 + \frac{6.90}{1 + \frac{5.25}{\left(\frac{P_r}{P} - \frac{P}{P_r}\right)^2}}} \quad (4.28)$$

Donde $P_r = 1.25 P_m$. El valor cuadrático medio de la modulación de fase cuando se emplea preénfasis es igual a --- $0.45 \omega_{\Delta}^2 / P_m P_o$, el cual en nuestro sistema se reduce a 0.197. Dado que este valor es menor que la unidad, se puede emplear la fórmula presentada previamente para el espectro de R.F.

La figura (4.8) muestra el cambio en el espectro de primer orden cuando se emplea preénfasis y la figura (4.9) --- muestra el cambio correspondiente en la distorsión en la parte superior del canal, debido a una portadora interferente no -- modulada.

4.14 INTERMODULACION DE CONVERSION AM/PM

Otra fuente de distorsión de intermodulación en ---- transmisores de microondas que emplean tubos de onda progresiva y Klystron, es la conversión de la variación de la envolvente de la onda recibida en modulación en fase para todas las -- portadoras transmitidas, efecto conocido como conversión AM/PM. La intermodulación de dichos sistemas dependen de una manera -- compleja de la amplificación y de las características de con--

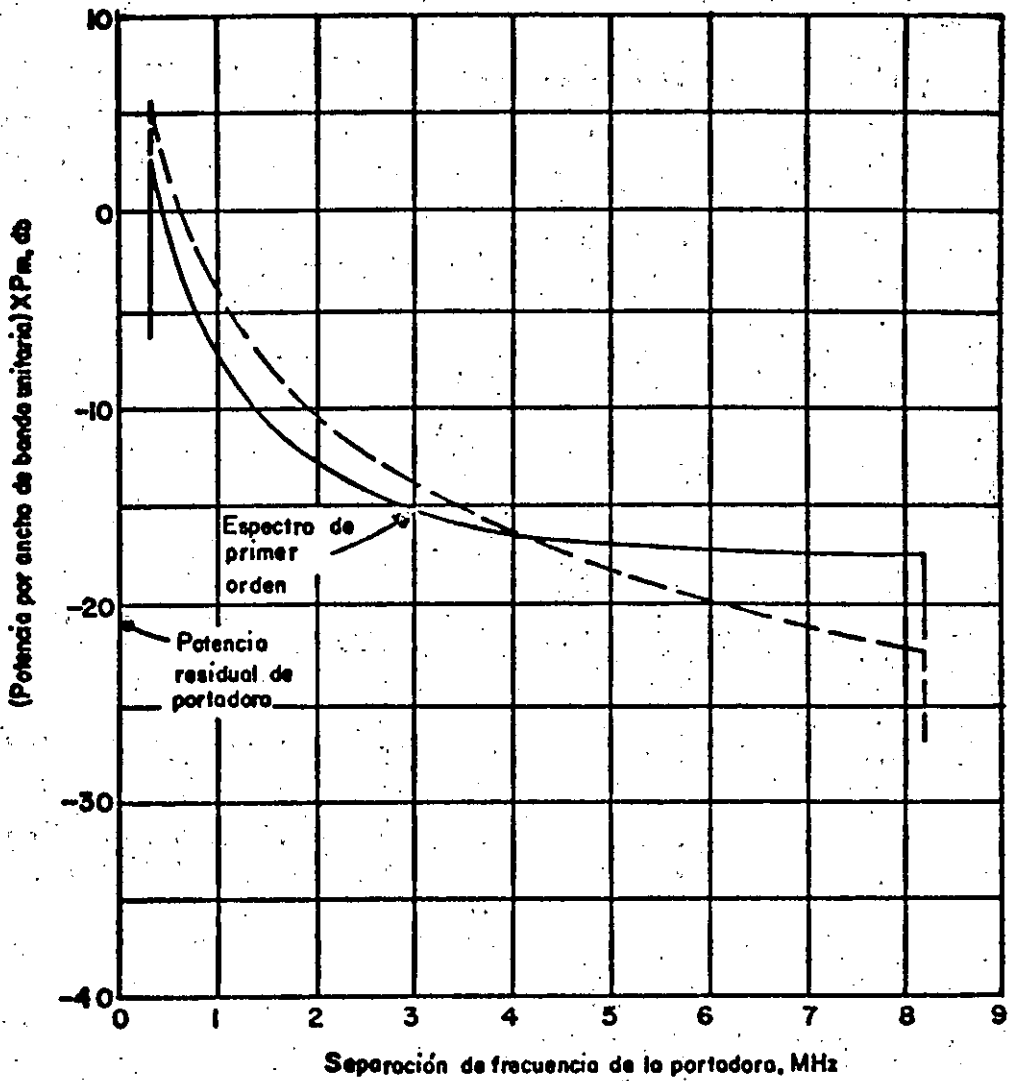


Fig. (4.8) Comparación del espectro de primer orden para una señal modulante de 1800 canales con preénfasis (línea continua) sin preénfasis (línea discontinua)

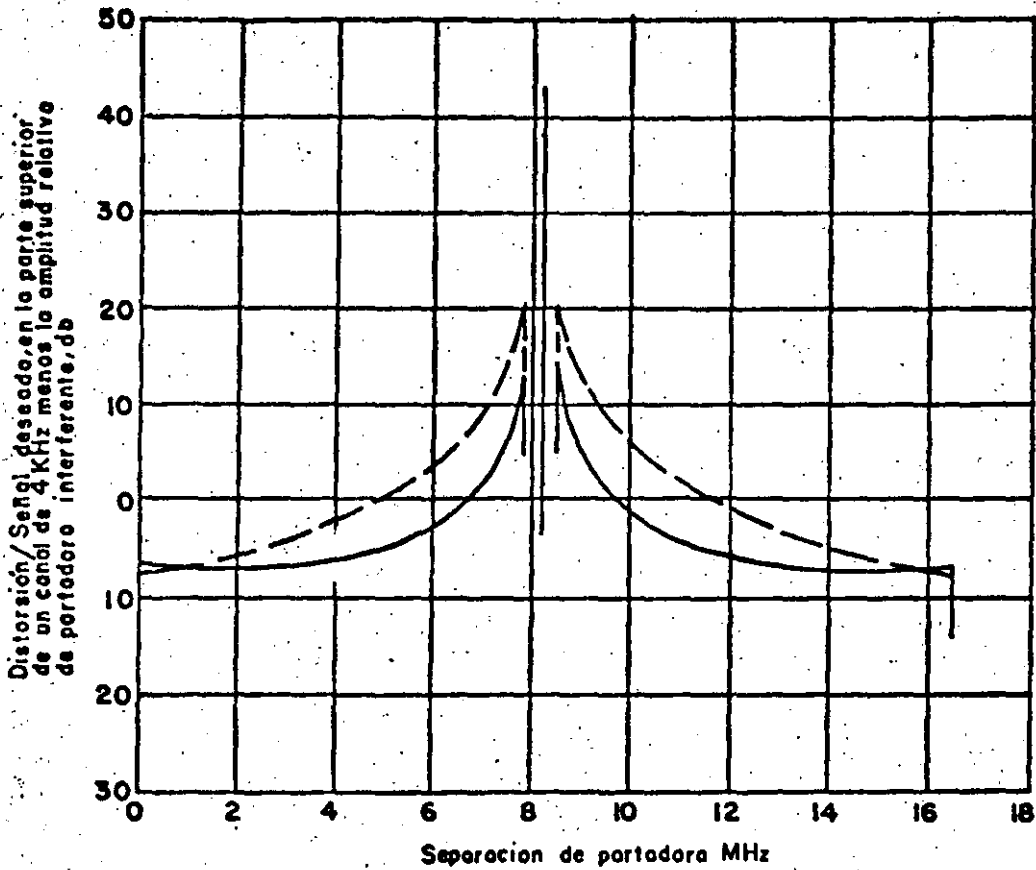


Fig. (4.9) Comparación de la distorsión debido a una portadora interferente no modulada en un sistema de 1800 canales con preénfasis (línea continua) y sin preénfasis (línea discontinua). La gama de separación de portadoras es de 0 a dos veces la máxima frecuencia modulante

versión AM/PM, en el número de portadoras y en el grado de modulación de portadora.

Como se indicó anteriormente, otra fuente de distorsión que puede encontrarse en sistemas de FM de multiporadoras, es la diafonía inteligible entre canales de voz de diferentes grupos de portadora. Dicha diafonía es originada por la distorsión de atenuación - frecuencia seguida por una conversión AM/PM y disminuye cuando se incrementa el número de grupos de portadoras. Por el contrario, la distorsión por intermodulación que origina interferencia se incrementa cuando aumenta el número de portadoras.

4.15 SIMULACION DE UN REPETIDOR

En el análisis siguiente se considera una característica ideal de la potencia no lineal de entrada - salida para todos los amplificadores, tal como se ilustra en la figura (4.10) para un tubo de onda progresiva (TOP), junto con el factor de conversión AM/PM (K) medido con una pequeña modulación en amplitud a la entrada. Para la no linealidad del tipo mostrado en la figura (4.10), es conveniente emplear una simulación limitada de las características instantaneas del voltaje entrada - salida tal como se muestra en la figura (4.11). Dicha representación puede lograrse que sea muy semejante a las mediciones de las características de transferencia de la potencia de portadora y la distorsión de intermodulación, seleccio-

nando adecuadamente la potencia suprimida (recortada) $P_c = C^2$

Cuando la entrada es una sola onda senoidal de potencia promedio $P_i = \frac{A^2}{2}$, donde A es la amplitud, la razón de la potencia de la onda senoidal de salida P_o a la potencia recortada P_c se representa por:

$$\frac{P_o}{P_c} = \frac{2}{\pi^2} \left[\left(1 - \frac{1}{2\rho}\right)^{1/2} + (2\rho)^{1/2} \operatorname{sen}^{-1} \left(\frac{1}{2\rho}\right)^{1/2} \right]^2 \quad (4.29)$$

$$= \frac{8}{\pi^2} \doteq 0.81 \quad \text{para} \quad \rho = \frac{P_i}{P_c} = \infty$$

Con una entrada de dos ondas senoidales de amplitud A para $\rho \geq 1/4$, la ecuación (4.29) toma la siguiente forma:

$$\frac{P_o}{P_c} = \rho \left[1 + \frac{4}{\pi^2} F(\rho) \right]^2 \quad (4.30)$$

$$= \left(\frac{8}{\pi^2}\right)^2 \doteq 0.65 \quad \text{para} \quad \rho = \frac{P_i}{P_c} = \infty$$

donde

$$F(\rho) = \int_0^\pi \left[(1 - u^2)^{1/2} - u \cos^{-1} u \right] \cos y \, dy \quad (4.31)$$

en la cual

$$u = \rho^{-1/2} + \cos y$$

y

$$\phi = \cos^{-1} (1 - \rho^{-1/2})$$

Para un gran número de portadoras, se aplica la siguiente relación para todos los valores de ρ

$$\begin{aligned} \frac{P_o}{P_c} &= \rho f_{er}^2 \left(\frac{1}{2\rho}\right)^{1/2} & (4.32) \\ &= \frac{2}{\pi} = 0.64 \text{ para } \frac{P_i}{P_c} = \infty \end{aligned}$$

donde f_{er} es la función de error

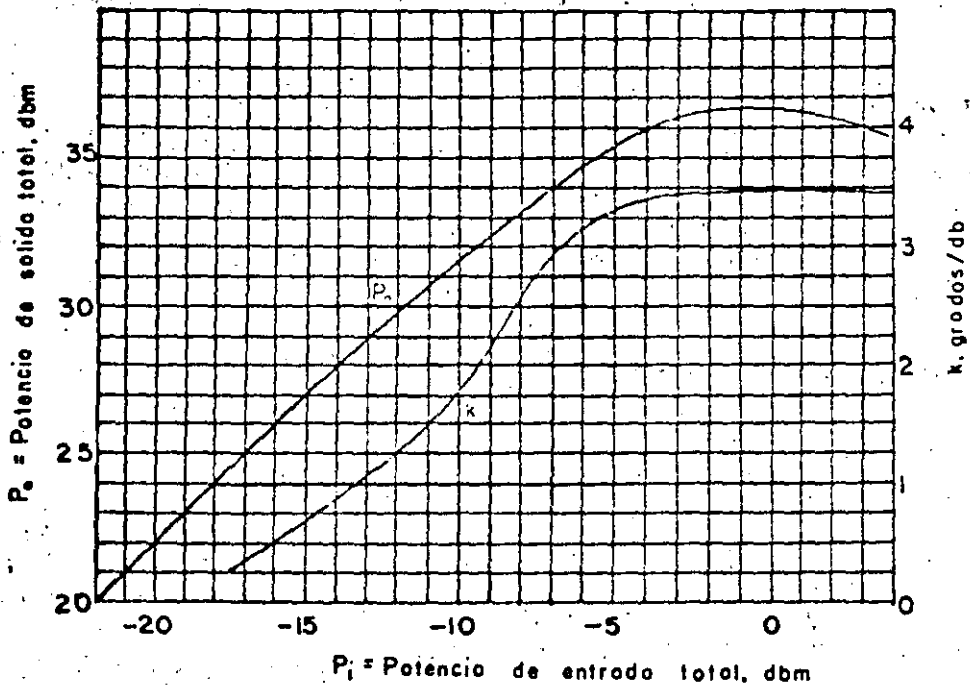


Fig. (4.10) Características de transmisión de una sola potencia de portadora y factor de conversión AM/PM para un potencial de hélice de 1525 volts.

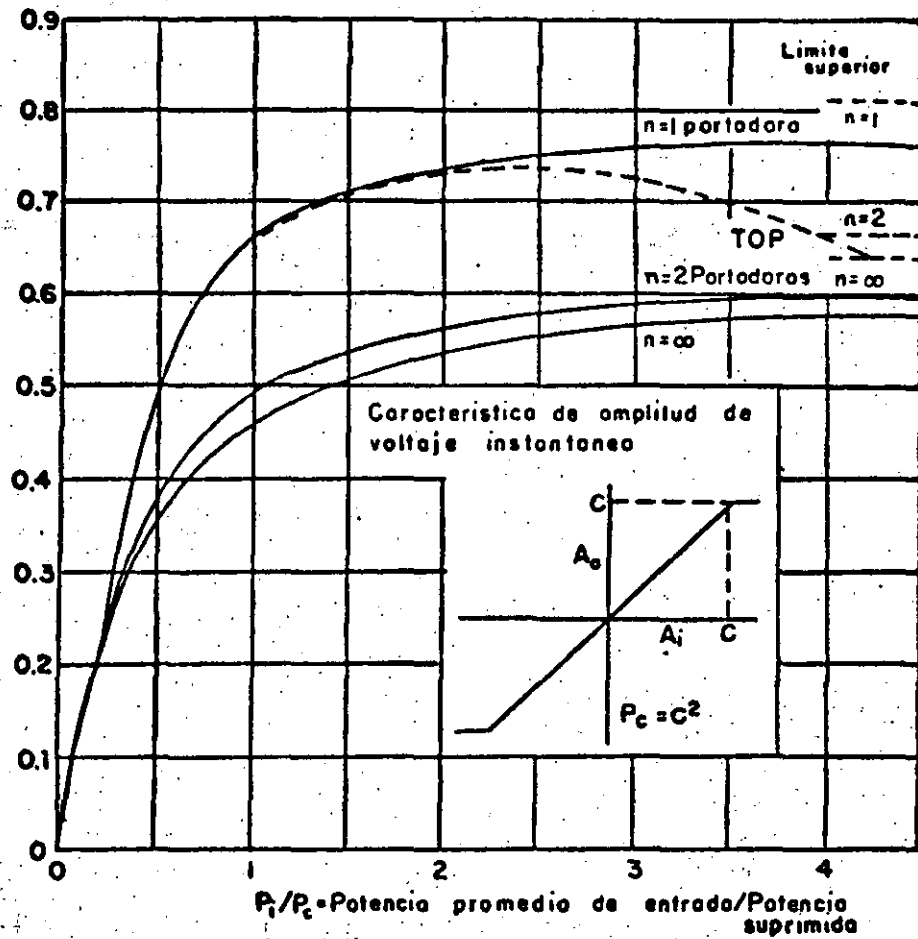


Fig. (4.11) Características de transferencia de la potencia no distorsionada de un amplificador no lineal con la representación de un limitador ideal de las características de amplificación de voltaje instantaneo, para la transmisión de una y varias portadoras.

4.16 INTERMODULACION DEBIDO A LA NO LINEALIDAD EN LA AMPLIFICACION

1.- Entrada de dos Portadoras de igual Amplitud. Considérese primero el caso en donde la entrada consiste de dos ondas senoidales de igual amplitud, las cuales se representan por

$$Z(t) = A (\cos \omega_1 t + \cos \omega_2 t) \quad (4.33)$$

Una medida convencional de la no linealidad de un amplificador, son los productos de intermodulación de tercer orden. Los productos de intermodulación de frecuencias $2\omega_1 - \omega_2$ y $2\omega_2 - \omega_1$ están dados por

$$\alpha_{21} = 2A_{21} = \frac{4A}{3\pi^2} \int_0^\pi (1 - u^2)^{3/2} \cos y \, dy \quad (4.34)$$

En donde u y θ se definieron en el párrafo anterior.

La razón de las amplitudes de cada producto de intermodulación de tercer orden a la amplitud de cada fundamental es α_2 , la cual se muestra graficada en la figura (4.12). La gráfica representa α_2^2 en función de $\rho = A^2/C^2$. Para $\rho = \infty$

$$\alpha_2 = \frac{1}{3}.$$

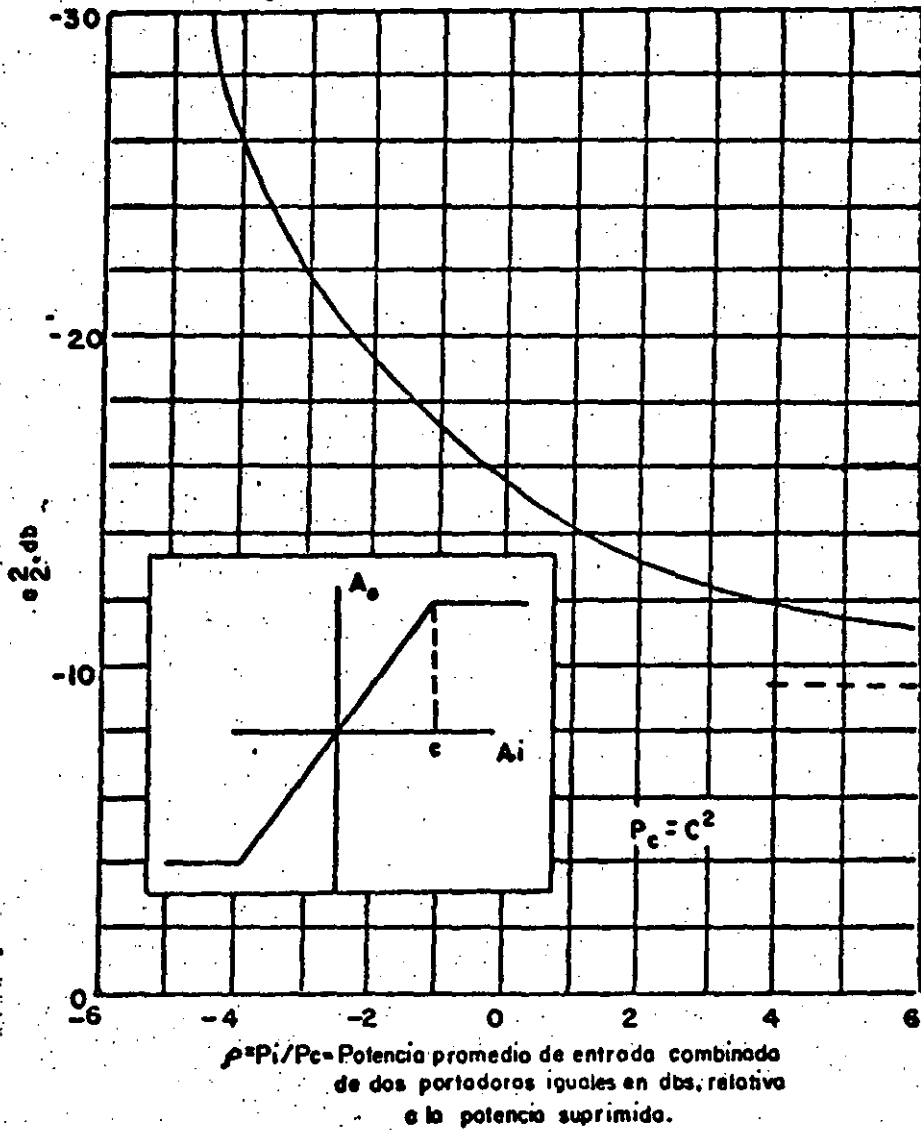


Fig. (4.12) Productos de intermodulación de tercer orden de las frecuencias $2f_1 - f_2$ y $2f_2 - f_1$ para dos portadoras de entrada de igual amplitud

2.- Entrada de Ruido Aleatorio Plano. Considérese ahora el caso donde la entrada consiste de un ruido aleatorio de banda angosta, o un gran número de portadoras moduladas en fase. La razón $\alpha_{\infty}^2(r)$ de la densidad de potencia de distorsión a la densidad de la potencia de la señal en la salida del amplificador a la frecuencia relativa r a media banda, dada por $r = f/(B_i/2) = 2f/B_i$, donde B_i = al ancho de banda del espectro de potencia de entrada de banda angosta plana, está dada por

$$\alpha_{\infty}^2 = \frac{\left[\frac{4}{\pi} \exp(-2x^2) \sum_{j=1,2,\dots} \frac{G(r) 2^{j+1} H_{2j-1}^2(x)}{4^{2nj} (j+1)!} \right]}{f \text{er}(X)} \quad (4.35)$$

donde $H_m(X)$ es un polinomio Hermitiano,

$$X^2 = P_c / 2P_i \text{ y}$$

$$G_m(r) = \frac{m}{2^{m-1}} \sum_{i=0,1,\dots} \frac{(-1)^i}{i!(m-i)!} (m-2i+r)^{m-1} \quad (4.36)$$

Para $X = 0$ y $P_i/P_c = \infty$, la ecuación (4.35) se reduce a

$$\alpha_{\infty}^2(r) = \frac{1}{2^2 1! 2!} G_3(r) + \frac{3^2}{2^4 2! 3!} G_5(r) + \frac{(3.5)^2}{2^6 3! 4!} G_7(r) + \dots \quad (4.37)$$

La razón $\alpha_{\infty} = \alpha_{\infty}(0)$ se muestra en la figura (4.13), junto con la razón correspondiente para un espectro de potencia Gaussiano.

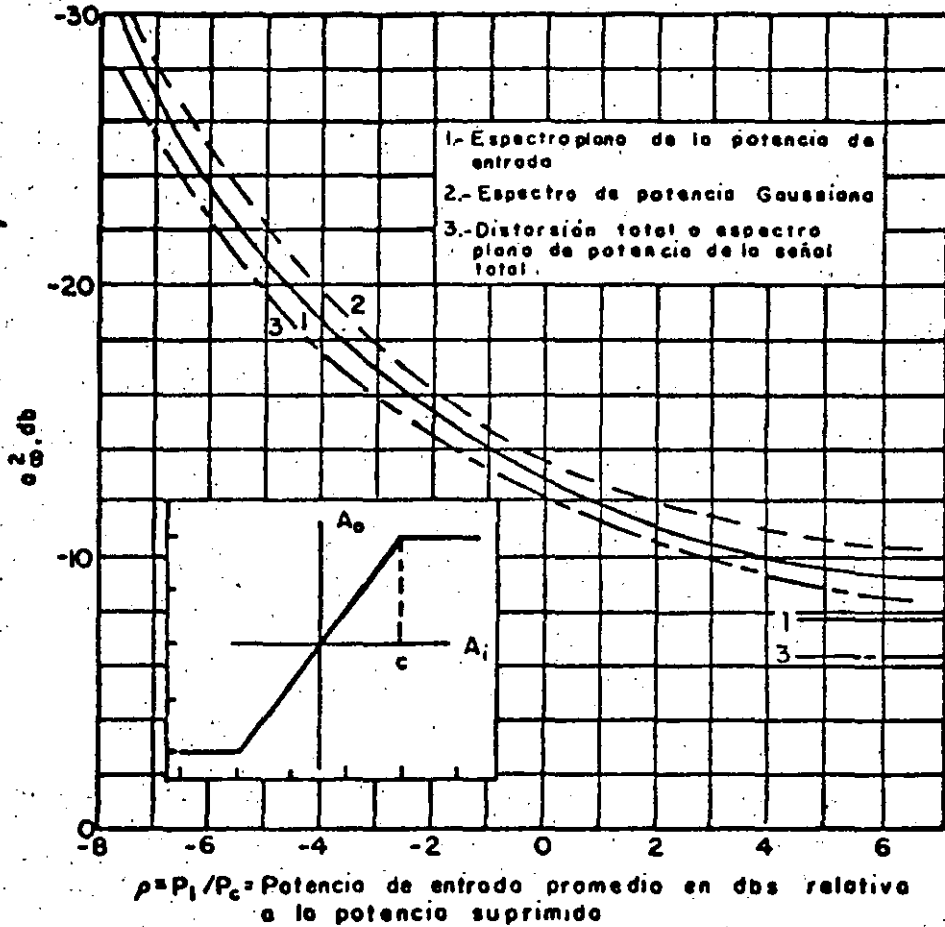


Fig. (4.13) Razón de la distorsión de intermodulación a la densidad de potencia de señal al centro de la banda de transmisión con una entrada de ruido plano.

4.17 INTERMODULACION DEBIDO A LA CONVERSION AM/PM

Considérese ahora la intermodulación debido a la conversión AM/PM para los mismos dos casos extremos tratados anteriormente, esto es, para dos ondas senoidales y para un número infinito de ondas senoidales moduladas en fase, o ruido aleatorio.

1.- Entrada de dos Portadora de igual Amplitud. La entrada del repetidor consiste de dos ondas senoidales de igual amplitud expresadas por la ecuación (4.33), la cual tam-

bién puede representarse de la siguiente forma:

$$z(t) = \bar{z}(t) \cos \omega_0 t \quad (4.38)$$

donde la envolvente $\bar{z}(t)$ está dada por

$$\bar{z}^2(t) = 2A^2 \left[1 + \cos \bar{\omega}t \right] \quad (4.39)$$

$$y \quad \bar{\omega} = \omega_2 - \omega_1$$

$$\omega_0 = (\omega_1 + \omega_2) / 2$$

Para comparación, considérese una onda senoidal modulada en amplitud como la empleada en la medición del factor de conversión K (el cual se representa en la figura 4.10), la cual está dada por

$$Y(t) = \sqrt{2} (A + A_1 \cos St) \cos \omega_0 t \quad (4.40)$$

Para $A_1 \ll A$, La envolvente cuadrada de la ecuación 4.40 es

$$\bar{Y}^2(t) \approx 2A^2 \left(1 + \frac{2A_1}{A} \cos St \right) \quad (4.41)$$

La potencia promedio es entonces la misma para ambos casos y es igual a $P_1 = A^2$

Supóngase ahora que la modulación de fase originada por la fluctuación de la envolvente, está representada por alguna relación funcional F de la envolvente cuadrada. La modulación de fase originada por la envolvente $\bar{Z}(t)$ de las dos portadoras de entrada de igual amplitud está representada por:

$$\psi_x(t) = F(\bar{Z}^2) = F\left[2A^2 (1 + \cos \bar{\omega}t)\right] \quad (4.42)$$

y la modulación de fase resultante debida a la onda senoidal - modulada en amplitud, está dada por

$$\phi_x(t) = F(\bar{Y}^2) = F\left[2A^2 \left(1 + \frac{2A_1}{A} \cos St\right)\right] \quad (4.43)$$

Estas relaciones pueden desarrollarse en series de Taylor como

$$\psi_x(t) = F(0) + 2A^2 (1 + \cos \bar{\omega}t) F'(0) + \frac{4A^2}{2!} (1 + \cos \bar{\omega}t) F''(0) + \dots \quad (4.44)$$

y

$$\phi_x(t) = F(0) + 2A^2 \left(1 + \frac{2A_1}{A} \cos St\right) F'(0) + \frac{4A^2}{2!} \left(1 + \frac{2A_1}{A} \cos St\right)^2 F''(0) + \dots \quad (4.45)$$

Las modulaciones de fase de las frecuencias $\bar{\omega}$ y S -- pueden expresarse como

$$\psi_{\bar{\omega}} = 2k_0 \cos \bar{\omega}t \quad (4.46)$$

$$\phi_s = \frac{4A_1}{A} k_0 \cos St \quad (4.47)$$

donde

$$k_0 = k_0(P_1) = P_1 F(0) + 2P_1^2 F''(0) + 4P_1^3 F'''(0) + \dots \quad (4.48)$$

$$y \quad P_1 = A^2$$

De la ecuación (4.47) se obtiene la siguiente relación entre la modulación de fase pico $\hat{\phi}_s$ y k_0

$$\frac{\hat{\phi}_s}{A_1/A} = 4k_0 \quad (4.49)$$

La fluctuaciones en la envolvente, expresada en decibeles es:

$$\frac{A_1}{A} \text{ db} = 20 \log \left(1 + \frac{A_1}{A} \right) \approx \frac{8.69A_1}{A}$$

Entonces

$$\frac{\hat{\phi}_s}{(A_1/A) \text{ db}} = \frac{4k_0}{8.69} \text{ rad/db} = 26.6k_0 \text{ grados/db} = K \quad (4.50)$$

o.

$$k_0 = 0.038 K \quad (4.51)$$

donde $K = K(P_1)$ es el factor de conversión que se muestra en la figura (4.10).

Regresando al caso de dos portadoras iguales, cuando la modulación de fase $\psi_x(t)$ se introduce en la ecuación (4.33) la onda resultante es

$$\begin{aligned} Z_o(t) &= \bar{Z}(t) \cos [\omega_o t + \psi_x(t)] \\ &= A \cos [\omega_1 t + \psi_x(t)] + A \cos [\omega_2 t + \psi_x(t)] \end{aligned} \quad (4.52)$$

en donde la modulación de fase $\psi_x(t)$ es de la forma general

$$\psi_x(t) = \psi_o + \psi_{\omega} + \psi_{2\omega} + \dots \quad (4.53)$$

La razón de las amplitudes de los productos de intermodulación de tercer orden de frecuencias $2\omega_2 - \omega_1$ y $2\omega_1 - \omega_2$ a la amplitud de cada fundamental está dada por:

$$\beta_2 = \frac{J_1(2k_o)}{\left[J_o^2(2k_o) + J_1^2(2k_o) \right]^{1/2}} = \frac{k_o}{(1 + k_o^2)^{1/2}} \text{ para } k_o \ll 1 \quad (4.54)$$

$$\approx 0.038 K \quad (4.55)$$

Donde k_o está dada por la ecuación (4.51). Con las características de conversión AM/PM que se muestran en la figura (4.10), la razón β_2 se muestra graficada en la figura --- (4.14) en función de la potencia total en entrada P_i en dbm.

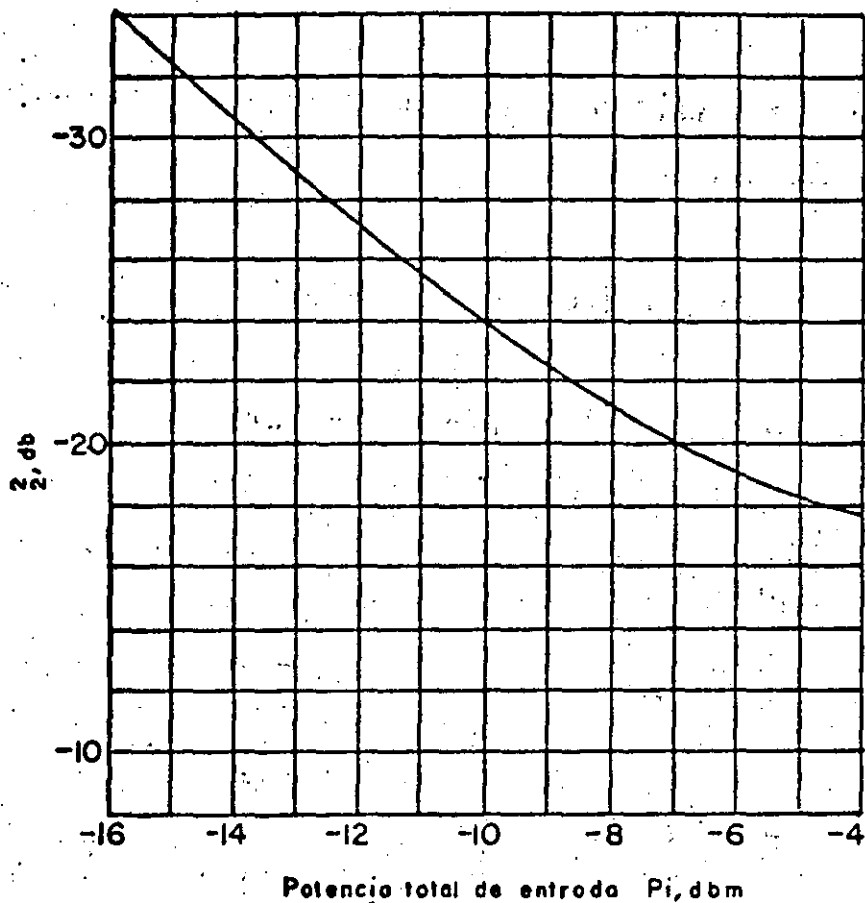


Fig. (4.14) Productos de intermodulación de tercer orden $2f_1 - f_2$ y $2f_2 - f_1$ propios de la conversión -- AM/PM para entrada de dos portadoras de --- igual amplitud, calculados empleando el factor de conversión AM/PM mostrado en la figura (4.10)

2.- Entrada de Ruido Aleatorio Plano. Considérese ahora que la entrada del repetidor está simulada por n ondas senoidales de amplitud A_i , representadas por

$$Z(t) = \sum_{i=1}^n A_i \cos \left[\omega_0 t + u_i t + \phi_i(t) \right] \quad (4.56)$$

Donde ω_0 se toma convenientemente como la frecuencia a -- media banda $u_i = \omega_i - \omega_0$ es la frecuencia a media banda de -- la portadora i y $\phi_i(t)$ es su modulación de fase.

La ecuación (4.56) puede expresarse mediante la relación siguiente:

$$z(t) = \bar{Z}(t) \cos\left[\omega_0 t + \psi_0(t)\right] \quad (4.57)$$

donde la envolvente $\bar{Z}(t)$ está dada por

$$z^2(t) = \left[\sum_{i=1}^n A_i \cos(u_i t + \phi_i) \right]^2 + \left[\sum_{i=1}^n A_i \sin(u_i t + \phi_i) \right]^2 \quad (4.58)$$

y la función de fase por

$$\text{tang } \psi_0(t) = - \frac{\sum_{i=1}^n A_i \sin(u_i t + \phi_i)}{\sum_{i=1}^n A_i \cos(u_i t + \phi_i)} \quad (4.59)$$

donde $\phi_i = \phi_i(t)$

La función de envolvente da lugar a una modulación de fase $\psi_x(t)$.

La onda de salida está dada por:

$$\begin{aligned} z_0(t) &= \bar{Z}(t) \cos\left[\omega_0 t + \psi_0(t) + \psi_x(t)\right] \\ &= \sum_{i=1}^n \cos\left[\omega_0 t + u_i t + \phi_i(t) + \psi_x(t)\right] \end{aligned} \quad (4.60)$$

en donde se muestra que la modulación de fase $\psi_x(t)$ aparece en cada una de las portadoras transmitidas.

Supóngase que la fluctuación de envolvente da lugar a una modulación de fase de acuerdo con la relación

$$\psi_x(t) = k_1 \left[Z(t) \right]^V \quad (4.61)$$

Para $V = 2$ esta corresponde al segundo término de la expresión (4.44) con $k_1 = F(0)$

El valor medio de $\psi_x(t)$ es

$$\psi_m = k_1 \int_0^{\infty} \bar{Z}^V P(\bar{Z}) d\bar{Z} \quad (4.62)$$

donde $P(\bar{Z})$ es la densidad de probabilidad de la fluctuación de envolvente.

La variancia de la fluctuación de envolvente es

$$\sigma_{\psi_x}^2 = k_1^2 \int_0^{\infty} \bar{Z}^{2V} P(\bar{Z}) d\bar{Z} - \psi_m^2 \quad (4.63)$$

Como la entrada consiste de un gran número n de ondas senoidales que se aproximan al ruido aleatorio; en este caso la envolvente tiene una distribución de probabilidad tipo-Rayleigh con una densidad de probabilidad.

$$P(\bar{Z}) = \frac{\bar{Z}}{\sigma^2} \exp\left(-\frac{\bar{Z}^2}{2\sigma^2}\right) \quad (4.64)$$

Donde $\sigma^2 = P_i$ es la potencia de entrada promedio

Empleando la ecuación (4.64), la variancia está re--
presentada por:

$$\sigma_{\psi_x}^2 = C(V) k_1^2 \sigma^{2V} = C(V) k_1^2 P_i^V \quad (4.65)$$

Donde $C(V)$ está rdlacionada a la función gama por:

$$C(V) = \Gamma(1 + V) - \Gamma^2\left(1 + \frac{V}{2}\right) \quad (4.66)$$

$$= 0.22 \quad \text{para } V = 1$$

$$= 1 \quad \text{para } V = 2$$

Para $V = 2$ se obtiene

$$\sigma_{\psi_x}^2 = k_1 P_i = k_0 \quad (4.67)$$

Donde k_0 es el factor de conversión representado por el pri--
mer término de la ecuación (4.48). También se tiene que:

$$\beta_{\infty}^2 = \frac{3}{2} \cdot k_0^2 = 2.2 \times 10^{-3} K^2 \quad (4.68)$$

Se concluye que para una entrada de ruido aleatorio de banda angosta con un espectro de potencia plano, el espectro de potencia de la fluctuación de fase $\psi_x(t)$ a la salida, será el mismo que la salida de un dispositivo no lineal de ley V con una entrada similar.

4.18 INTERMODULACION COMBINADA

En este párrafo se considera la distorsión de intermodulación combinada que resulta de la no linealidad en la amplificación, junto con la conversión AM/PM para los mismos casos límites que en el análisis anterior.

1.- Entrada de dos Portadoras de igual Amplitud

Los productos de intermodulación que resultan de una conversión AM/PM están virtualmente en cuadratura con aquellos originados por la no linealidad en la amplificación, previendo que $k_0 \ll 1$, los productos de intermodulación combinados están representados por:

$$\gamma_2^2 = \alpha_2^2 + \beta_2^2 \quad (4.69)$$

En la figura (4.15) se muestra la razón α_2^2 obtenidas a partir de las curvas de la figura (4.12) con $P_0 = -4$ dbm, junto con la razón β_2^2 obtenida de la ecuación (4.62) empleando los valores de K que se muestran en la figura (4.10) y la razón combinada γ_2^2 .

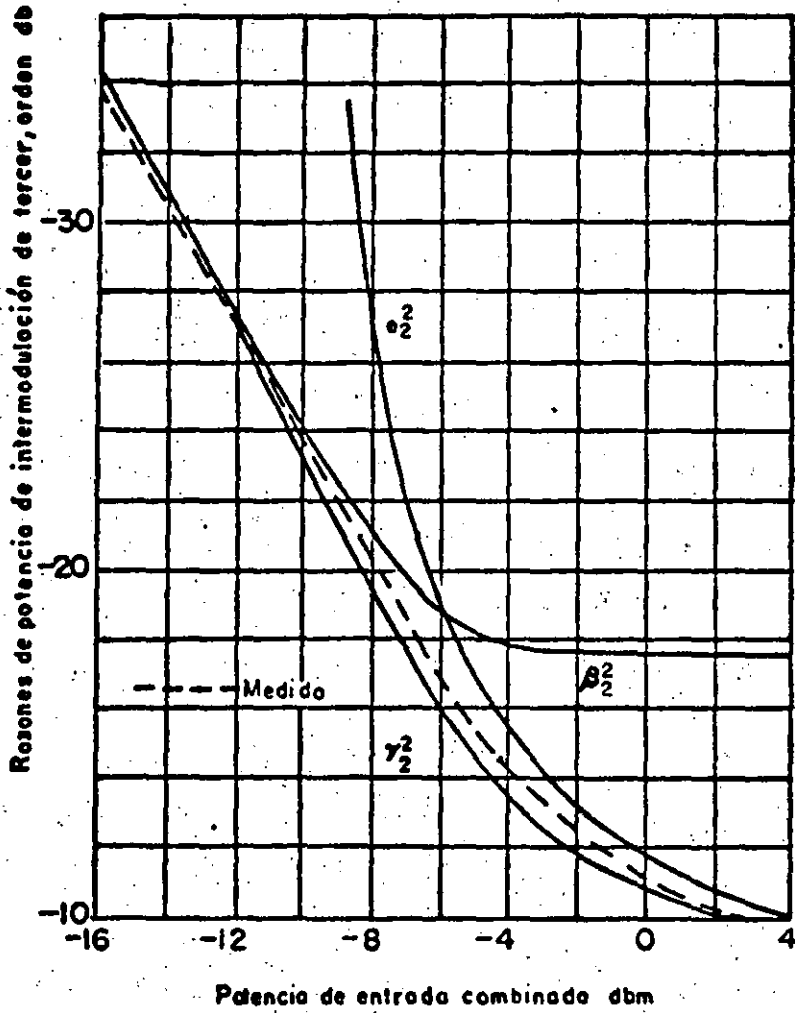


Fig. (4.15) Productos de intermodulación de tercer orden para una entrada de dos portadoras de igual amplitud

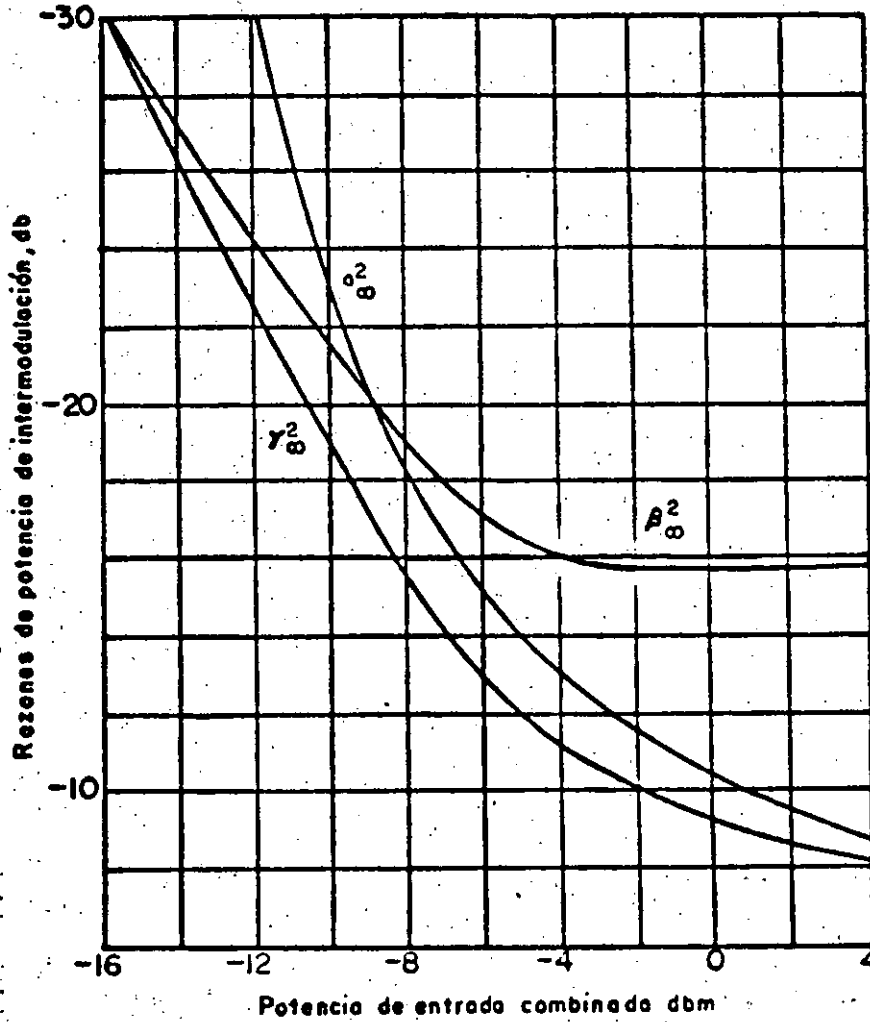
Se concluye de estas curvas que para bajas potencias de entrada, la intermodulación de tercer orden está originada principalmente por la conversión AM/PM mientras que para altas potencias de entrada, la no linealidad de la amplificación es la principal causante

2.- Entrada de Ruido Aleatorio Plano

En este caso la razón resultante de la densidad de potencia de distorsión de intermodulación promedio a la densidad de potencia de señal en el centro de la banda con un gran número de portadoras moduladas en fase está representada por:

$$\gamma_{\infty}^2 = \alpha_{\infty}^2 + \beta_{\infty}^2 \quad (4.70)$$

Donde α_{∞}^2 se muestra en la figura (4.13), mientras que β_{∞}^2 se obtiene de la ecuación (4.68) empleando los valores de K dados en la figura (4.10). Estas curvas se muestran graficada en la figura (4.16). En la figura (4.17) se muestran los resultados obtenidos en las mediciones con una entrada de ruido aleatorio plano para un TOP que tiene la misma amplificación que la que se muestra en la figura (4.10) pero un factor K ligeramente mayor para entradas abajo de - 6 dbm.



Fgi. (416) Distorsión de intermodulación para una entrada de ruido aleatorio

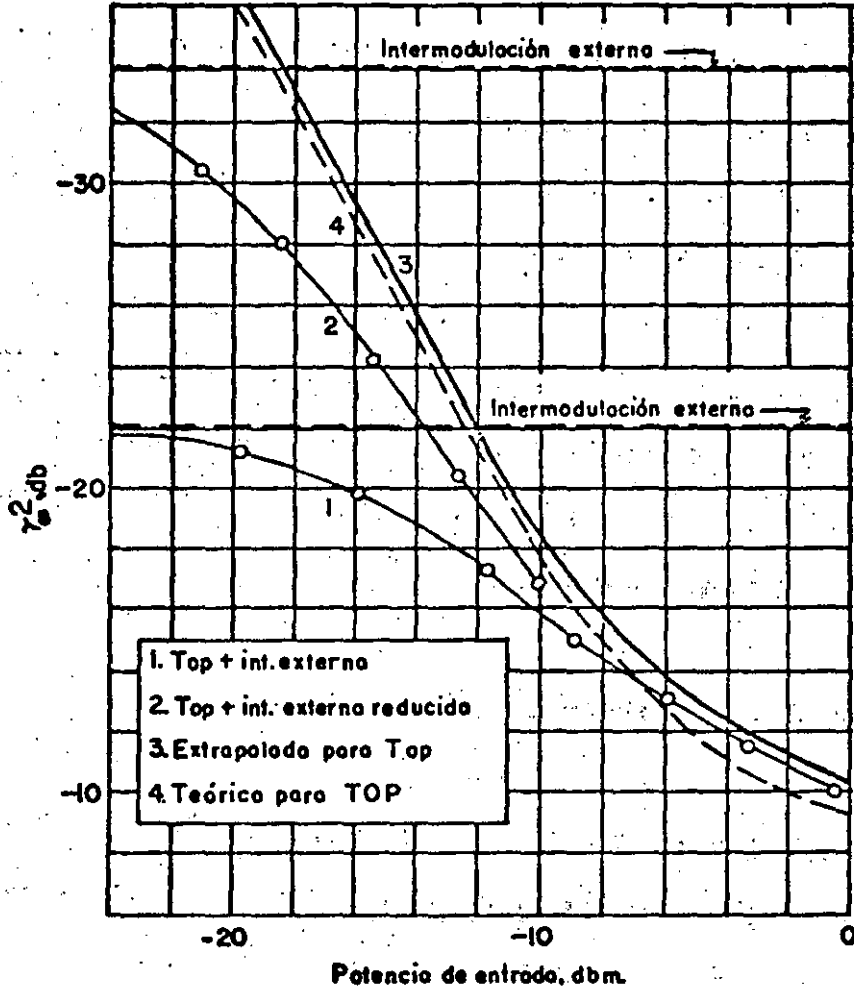


Fig. (4.17) Razón de intermodulación teórica en función de las medidas para una entrada de ruido aleatorio plano

METODO DE RUIDO BLANCO PARA MEDIR EL RUIDO DE INTERMODULACION EN SISTEMAS TELEFONICOS MULTICANALES

Existen varios métodos para medir el ruido de intermodulación en sistemas multicanales, de los cuales el que emplea una carga con ruido blanco es el más indicado para medir las características de funcionamiento de un sistema FDM/FM. -- Como ya se ha indicado, el ruido blanco tiene propiedades similares a las de las señales de un sistema multicanal FDM. Consecuentemente, cuando la señal de ruido se aplica al sistema -- con un nivel de potencia adecuada, se simula un sistema multicanal completamente cargado.

TECNICAS DE INTERMODULACION CON RUIDO

La figura (4.18) muestra un diagrama a bloques en el cual se indica el arreglo para medir la distorsión de intermodulación. El generador de ruido de banda ancha produce -- una banda base correspondiente a la señal multicanal que se -- está simulando, pero con ranuras específicas, las cuales pueden producirse mediante filtros en la parte inferior, media y superior del espectro de frecuencia de la banda base. Los filtros que tienen una pérdida de inserción mínima de 80 dbs, se les conoce como filtros de ranura o supresores de banda. El -- ruido se mide en la banda suprimida mediante un receptor de -- ruido con filtros adecuados (o con un vóltmetro selectivo en --

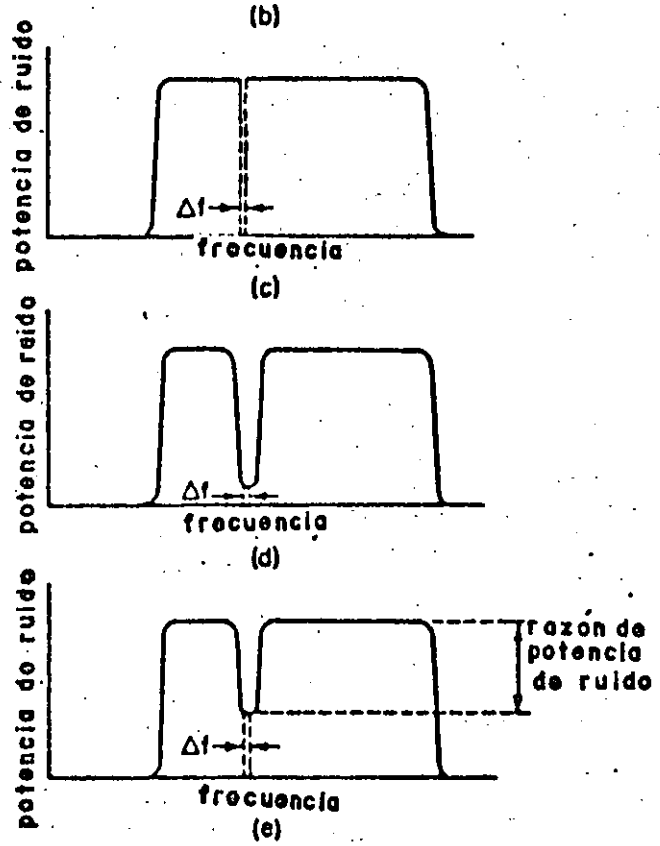
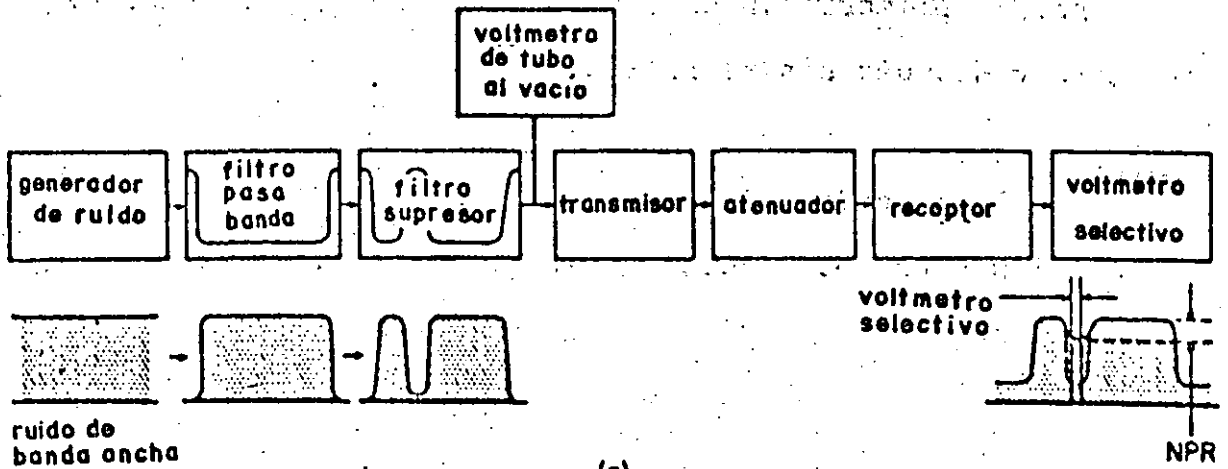


Fig. (4.18) Diagrama a bloques para medir el ruido de intermodulación de un sistema multicanal

frecuencia), primero con el filtro de ranura intercalada en el circuito y después sin el filtro.

De acuerdo a la recomendación 399-1 del CCIR, las -- frecuencias para los canales se muestran en la tabla (IV - 2) de medición.

Tabla (IV-2) Frecuencias centrales de los canales de medición, KHz

Capacidad del sistema (canales)	Límites de banda ocupada por los canales telefónicos (KHz)	Frecuencias de corte efectivas de los filtros limitadores de banda KHz		Frecuencias de los canales de medición disponibles -- KHz
		Pasa altas	Pasa bajas	
60	60 - 300	60 ± 1	300 ± 2	70 270
120	60 - 552	60 ± 1	552 ± 4	70 270, 534
300	60 - 1300 64 - 1296	60 ± 1	1,296 ± 8	70 270, 534, 1248
600	60 - 2540 64 - 2660	60 ± 1	2,600 ± 20	70 270, 534, 1248, 2438
960	60 - 4028 64 - 4024	60 ± 1	4,100 ± 30	70 270, 534, 1248, 2438, 3886
900	316 - 4188	316 ± 5	4,100 ± 30	534, 1248, 2438, 3886
1,260	60 - 5636 60 - 5564	60 ± 1	5,600 ± 50	70 270, 534, 1248, 2438, 3886, 5340
1,200	316 - 5564	316 ± 5	5,600 ± 50	534, 1248, 2438, 3886, 5340
1,800	312 - 8120 312 - 8204 316 - 8204	316 ± 5	8,160 ± 75	534, 1248, 2438, 3886, 5340 7,600
2,700	312 - 12336 316 - 12388 312 - 12388	316 ± 5	12,360 ± 100	534, 1248, 2438, 3886, 5340, 7,600, 11,700

Las características de atenuación de los filtros supresores de banda a la entrada del sistema, se presentan en la tabla

Tabla (IV - 3) Atenuación de los filtros supresores de banda.

Frecuencia central f_c (KHz)	Ancho de banda (KHz) con respecto a f_c sobre el cual la discriminación debe ser de al menos			Ancho de banda (KHz) con respecto a f_c fuera de la cual la discriminación no debe exceder	
	70 db	55 db	30 db	3 db	0.5 db
70	± 1.5	± 2.2	± 3.5	± 12	
270	± 1.5	± 2.3	± 2.9	± 8	
534	± 1.5	± 3.5	± 7.0	± 15	
1 248	± 1.5	± 4.0	± 11.0	± 35	
2 438	± 1.5	± 4.5	± 19.0	± 60	
3 886	± 1.5	± 15.0	± 30.0	± 110	
		± 1.8	± 3.5	± 12	± 100
5 340	± 1.5	± 2.2	± 4.0	± 14	± 140
7 600	± 1.5	± 2.4	± 4.6	± 16	± 200
11 700	± 1.5	± 3.0	± 7.0	± 20	± 300

El método de hacer una medición es de la siguiente manera:

El nivel r.m.s. del generador de ruido se coloca de acuerdo a las recomendaciones del CCIR

$$(-15 + 10 \log_{10} N) \text{dbm}_0, \quad N \geq 240 \text{ canales}$$

y

$$(-1 + 4 \log_{10} N) \text{dbm}_0, \quad 12 < N \leq 240 \text{ canales}$$

donde:

N - Número de canales de voz espaciados cada 4 KHz.

Estas relaciones de carga con ruido de banda ancha (NCR) se muestran gráficamente en la figura (4.19)

El generador se coloca al nivel correspondiente del número de canales deseados y un ruido de banda plana se aplica con el nivel adecuado al sistema bajo prueba. La salida del sistema se aplica al receptor del medidor de ruido, el cual se coloca a la frecuencia de supresión. El receptor es esencialmente un dispositivo del tipo de medición de pérdida de inserción, ya que opera siempre a ganancia completa y las mediciones se hacen por medio de un atenuador calibrado.

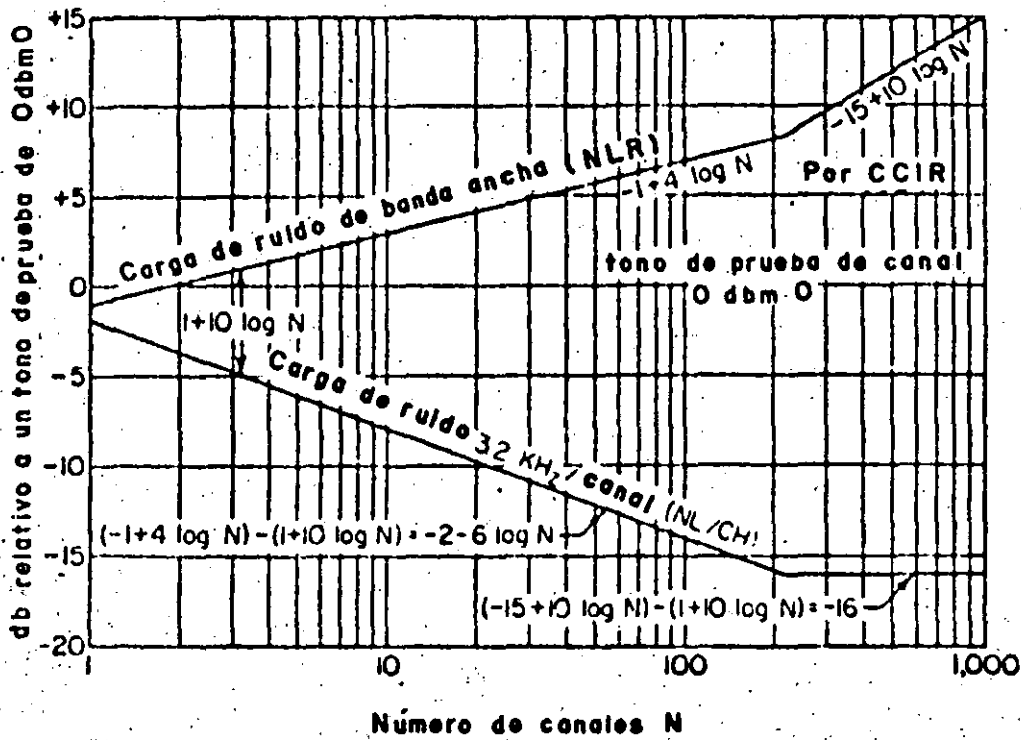


Fig. (4.19)

El filtro supresor de banda apropiado se inserta --- dentro del circuito en el extremo transmisor y el atenuador de entrada del receptor se reajusta para restaurar la deflexión original del medidor. La diferencia entre las dos lecturas -- del atenuador en el receptor es la razón de potencia de ruido. (NPR) para el nivel de carga particular y la frecuencia de supresión correspondiente.

Cuando este conjunto de prueba se emplea en un sistema de transmisión el cual está en operación, las mediciones incluyen ruido de intermodulación generado por los equipos terminales de radio, guías de onda y el medio de transmisión. Con el fin de medir solamente el ruido de intermodulación originado por los equipos de radio, el transmisor modulado por el generador de ruido se conecta directamente al receptor a través de un atenuador apropiado.

RAZON DE POTENCIA DE RUIDO Y RAZON DE SEÑAL A RUIDO

La razón de potencia de ruido (NPR) de un sistema -- cargado con un nivel particular de señal de ruido de prueba, -- puede definirse como la razón de la potencia de ruido en un pequeño ancho de banda arbitrario del pasabanda a la potencia de ruido en el mismo ancho de banda dentro de una banda suprimida. El NPR variará con la carga y generalmente con la posición de la banda suprimida en el espectro de frecuencia de ruido, de -- tal forma que no puede expresarse como una sola figura. Los --

resultados se presentan más apropiadamente en forma de curvas- (ó tablas) de NPR en función de la carga para cada frecuencia de medición; ó de NPR en función de la frecuencia para cada nivel de carga. Estas curvas proporcionan datos fundamentales del funcionamiento del sistema en una forma rápida, simple y exacta. Lo más importante de todo es que el sistema está cargado de una manera real y se toma en cuenta el ruido que proviene de cualquier fuente así como los productos de intermodulación de cualquier orden que caen dentro de los canales medidos.

Es conveniente expresar NPR en función de una SNR -- donde la señal es el tono de prueba del canal de referencia es el tono de prueba del canal de referencia a 0 dbm; esto es la razón del tono de prueba al ruido de intermodulación en el canal. La conversión de NPR es simplemente un mecanismo de sumar un factor de conversión el cual puede considerarse como -- una tolerancia para la diferencia entre el nivel del tono de prueba del canal y la proporción de la potencia de ruido total cargado, el cual se aplica efectivamente a cualquier canal.

La carga de ruido por canal (NL/Ch) en una ranura de 3.2 KHz está abajo de la carga de ruido de banda base por una cantidad.

$$10 \log_{10} \frac{N(4\text{KHz})}{3.2 \text{ KHz}} = 1 + 10 \log N \text{ db}$$

a la cual se le conoce como la razón del ancho de banda (BWR) - en db.

La razón NL/ch. También se encuentra graficada en la figura (4.19). Dado que

$$\text{NPR} = \frac{\text{NL/ch}}{\text{Ruido IM/ch}}$$

y

$$\text{SNR} = \frac{0 - \text{dbm}(\text{Nivel del tono de prueba})}{\text{Ruido IM/ch}}$$

y dado que NL/ch con respecto al 0 dbm del tono de prueba es - igual a:

$$(-1 + 4 \log N) - (1 + 10 \log N) = (-2 - 6 \log N) \text{db}$$

$$N < 244$$

y

$$(-15 + 10 \log N) - (1 + 10 \log N) = -16 \text{ db}$$

$$N \geq 240$$

(Ver figura 4.19)

entonces:

$$\begin{aligned}
 \text{SNR}(\text{db}) &= \text{NPR} + (\text{Odbm} - \text{NL}/\text{ch}) \\
 &= \text{NPR} + \left[0 - (-2 - 6 \log N) \right] \\
 &= \text{NPR} + 2 + 6 \log N && N < 240 \\
 &= \text{NPR} + 16 && N \geq 240
 \end{aligned}$$

Esto algunas veces se expresa como

$$\text{SNR}(\text{db}) = \text{NPR}(\text{db}) + \text{BWR}(\text{db}) - \text{NLR}(\text{db})$$

donde NLR es la razón de carga de ruido expresada por:

$$\text{NLR} = 10 \log_{10} \frac{\text{Señal de carga de ruido de banda base}}{\text{Señal de tono de prueba del canal}}$$

Como ejemplo, considerese un sistema de 120 canales.

El generador de ruido se coloca a un nivel r.m.s. de $(-1 + 4 \log 120) = 7.5$ dbm con respecto a 0 - dbm del tono de prueba del canal. Entonces NL/ch es $(-2 - 6 \log 120) = 14.5$ dbm.

El nivel en la ranura se mide con la ranura filtrada en el transmisor. Supongase que la lectura medida es de -64.5 dbm. Entonces, la NPR es:

$$\text{NPR} = -14.5 \text{ dbm} - (-44.5 \text{ dbm}) = 30 \text{ db}$$

entonces:

$$\begin{aligned} \text{SNR}(\text{db}) &= \text{NPR} + 2 + 6 \log 120 \\ &= 30 + 14.5 = 44.5 \text{ db} \end{aligned}$$

estos valores son para las mediciones planas. Por ejemplo, la SNR obtenida empleando un medidor de ruido FIA ponderado es 3 db más grande que la SNR obtenida en un medidor de ruido plano.

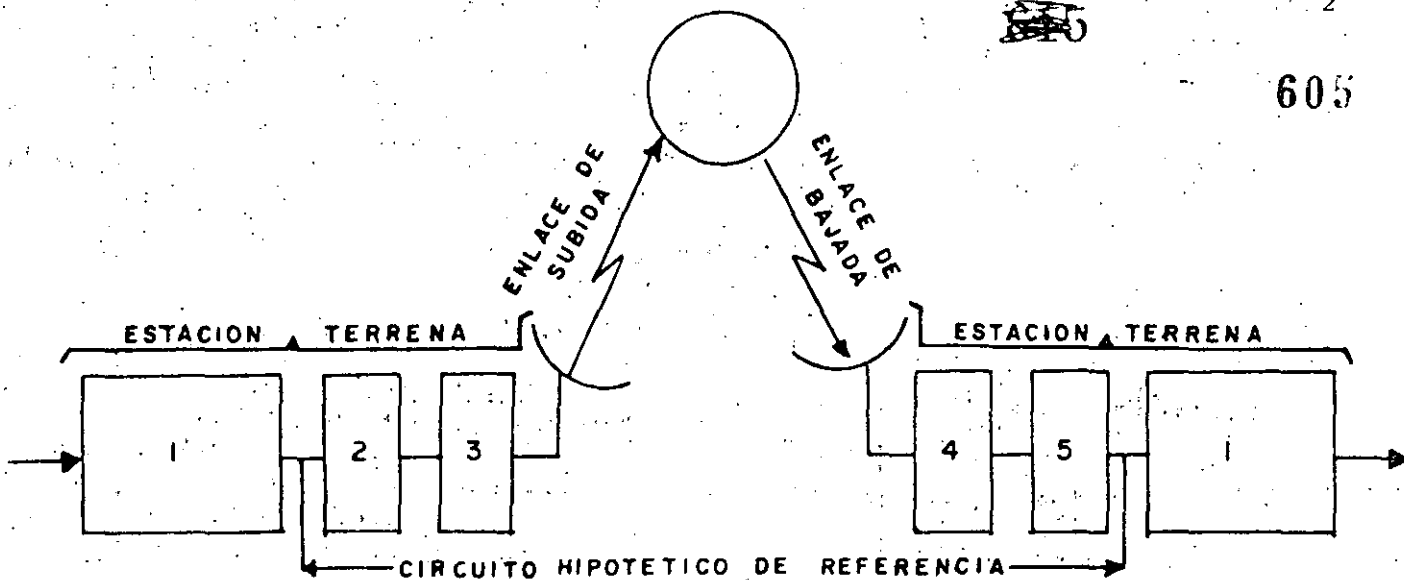
1 Recomendaciones del CCIR que relacionan los objetivos de calidad de circuitos F.M.

1.1 Circuito Hipotético de referencia.

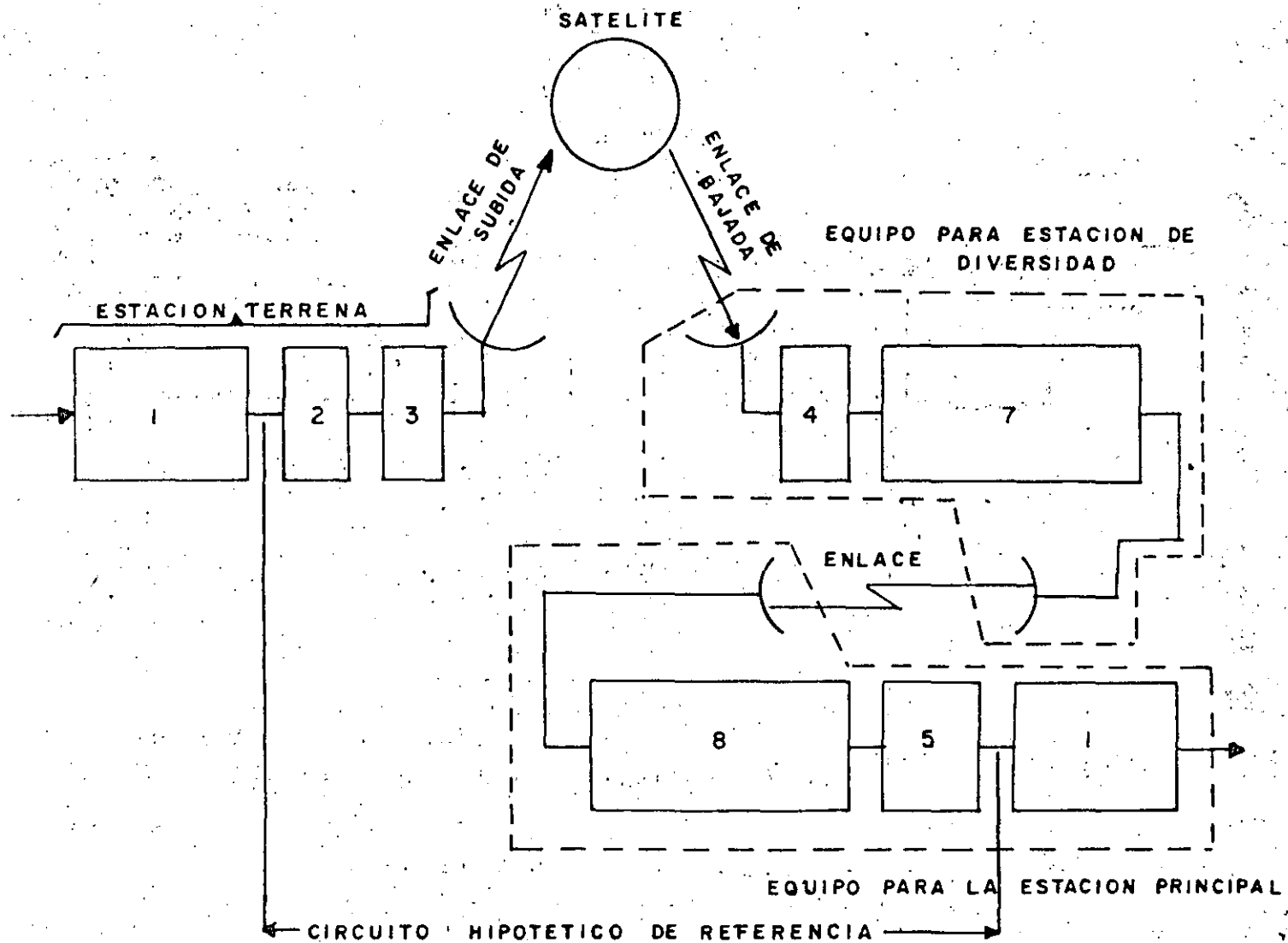
Cuando se consideran objetivos de calidad de un circuito de comunicaciones por satélite, o cuando se diseña un enlace por satélite es necesario primero que todo definir la sección de circuito a las cuales las consideraciones serán dadas. En el CCIR (Recomendación 352-3) se define un circuito hipotético de referencia como una norma del enlace de satélite para la transmisión de televisión y telefonía en los servicios de satélite fijos como sigue:

- a) El circuito hipotético de referencia consiste de un enlace tierra-espacio-tierra en el cual la porción de espacio puede contener una o más trayectorias satélite a satélite.
- b) Para estaciones terrenas no conectadas en diversidad de sitio este circuito incluye un par de equipos de modulación y Demodulación para trasladar la señal de banda base a la portadora de R.F. y de la portadora de R.F. a la banda base.
- c) Para estaciones terrenas con diversidad en sitio, el circuito hipotético de referencia también incluye el enlace terrestre necesario y, el equipo apropiado adicional de modulación y/o de modulación.

Debe notarse que este circuito de referencia no incluye enlaces entre estas estaciones terrenas y sus centros de conmutación asociadas. En el caso de un circuito de televisión un conversor estandard de televisión y el equipo para inserción de señales e intervalo de barrido de campo o línea no son incluidos en el circuito de referencia.

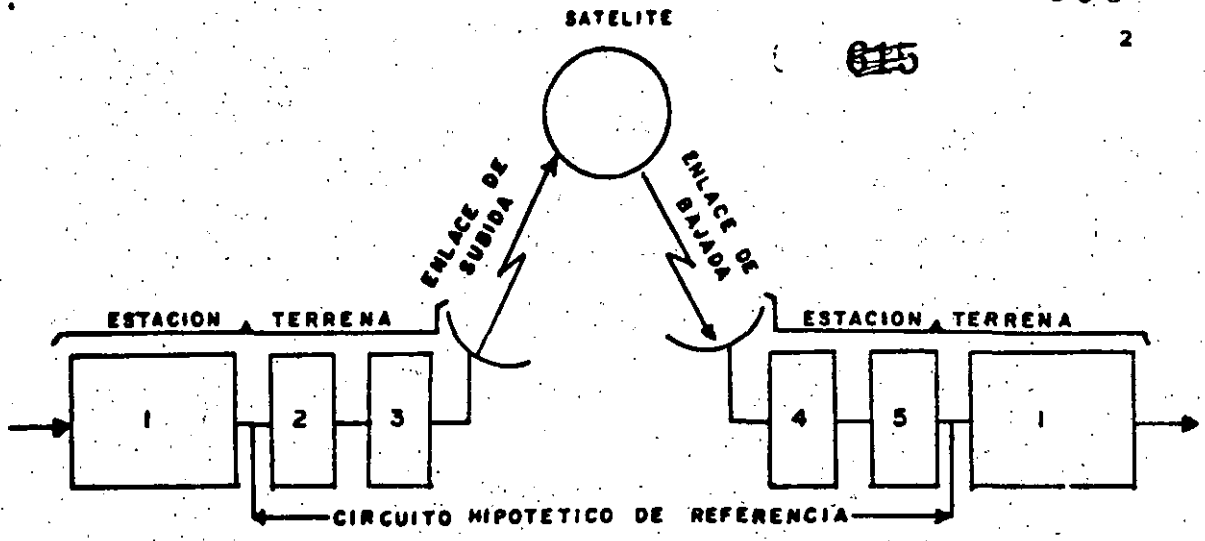


a) Caso en el cual no se incluye la estación de diversidad.

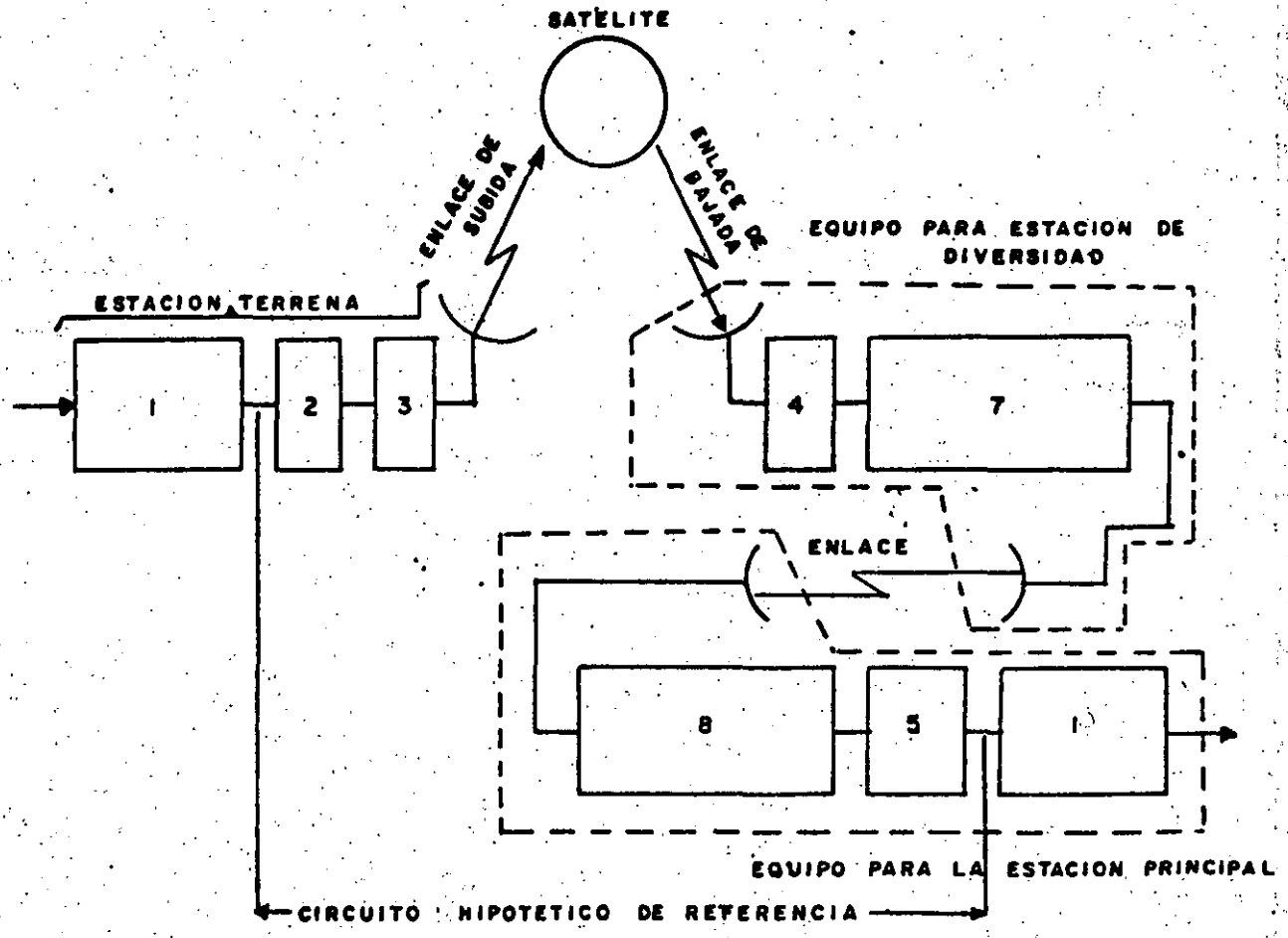


b) Caso donde se incluye una estación de diversidad.

015



a) Caso en el cual no se incluye la estación de diversidad.



b) Caso donde se incluye una estación de diversidad.
Fig.(1) Circuito Hipotético de referencia.

Fig. (1). Circuito hipotético de referencia.

Descripción de los diagramas de bloques.

1. Equipo para enlace terrestre.
2. Modulador.
3. Transmisor.
4. Receptor.
5. Demodulador.
7. Equipo para enlace de interconexión.
8. Equipo para enlace de interconexión.

1.2 OBJETIVOS DE RUIDO PARA CIRCUITOS TELEFONICOS.

Una de las normas básicas que relacionan al diseño de circuitos en los servicios de satélite fijos es el que consierne al ruido del canal en circuitos telefónicos multicanalizados. El CCIR recomienda los siguientes valores como porcentajes en tiempo de ruido provisional, objetivos que serán aplicados a un punto relativo con nivel cero en un canal telefónico FDM en el circuito de referencia hipotético (recomendación 353-3)

- a) La potencia media en un minuto no debe exceder a $10\ 000\ p_{Wop}$ por más del 20% de cualquier mes.
- b) La potencia media en un minuto no debe exceder a $50\ 000\ p_{Wop}$ por más del 0.3% de cualquier mes.
- c) La potencia del ruido en un tiempo de integración de 5 m seg. no debe exceder a $1\ 000\ 000\ p_{W0}$ no ponderados por mas del 0.01% de cualquier año.

Debe de observarse que la potencia de ruido indicado anteriormente debe incluir el ruido de interferencia debido a otros sistemas de satélite y otros sistemas de microondas de superficie así como el ruido resultante de la absorción atmosférica y la temperatura de ruido incrementada debido a la lluvia. Por otro lado como el objetivo de ruido del inciso c) no debe incluirse el tiempo en el cual el objetivo dado es excedido debido al ruido de interferencia del sol. Las interrupciones cortas menores de 10 segundos deben de tratarse como equivalentes al caso donde la potencia de ruido de un circuito es mayor que $10^6\ p_{W0}$ no ponderados. En el inciso a) anterior $10^4\ p_{Wop}$ se considera como el objetivo de calidad para un estado ordinario y en b) $5 \times 10^4\ p_{Wop}$ deben de aplicarse a los casos donde ocurre degradación de la calidad del circuito (por ejemplo degradación debido a la lluvia). El último caso puede especificarse como el umbral de la calidad de circuitos telefónicos para uso comercial. En el inciso c) se considera como una especificación que relaciona a interrupciones cortas de circuito el cual puede originar desconexiones en facilidades de conmuta-

ción en circuitos telefónicos ó errores de caracter en circuitos telegráficos con portadora de frecuencia de voz, etc. Debe también observarse que las especificaciones observadas anteriormente no son objetivos de confiabilidad sino objetivos de funcionamiento.

1.3 OBJETIVOS DE RUIDO PARA CIRCUITOS DE TELEVISION.

Con respecto al funcionamiento de la transmisión de circuitos de televisión, la recomendación 567 del CCIR especifica varios criterios. entre estos, el más importante es el que relaciona al ruido aleatorio continuo el cual se especifica de la siguiente manera.

La razón señal a ruido para ruido aleatorio continuo no debe caer - abajo de 53 db por más del 1% de cualquier mes ó no estar abajo de 45 db por más del 0.1% de cualquier mes, cuando se está empleando la red cargada (ponderada) que tenga una característica de ponderación unificada. (ver figura 9).

Antes de que se redactara esta recomendación en la asamblea plenaria del CCIR en junio de 1978, diferentes valores de $\frac{S}{N}$ se aplicaron a normas de televisión individuales, mientras que la nueva recomendación (Rec. 567) especifica un solo criterio, para normas de 525 y 625 líneas. Debe de observarse que la frecuencia de corte del filtro pasabajos para medir el ruido aleatorio continuo es de 5MHz, el cual ha sido especificado por conveniencia que toma el valor medio de las frecuencias límites superiores de los anchos de banda requeridas para normas de 525 y 625 líneas.

2 DISEÑO DE ENLACES PARA TELEFONIA MULTICANAL.

2.1 RUIDO

Como se estableció, la potencia media en un minuto en el circuito de referencia hipotético para telefonía en el servicio de satélites fijos se requiere que sea igual o menor que 10 000 μW_{op} para el 80% del tiempo. Por lo tanto en el diseño de un enlace por satélite los parámetros de transmisión están generalmente determinados para que satisfagan este criterio en

en el estado normal del circuito. El ruido generado dentro del enlace por satélites puede clasificarse de la siguiente manera.

- a) Ruido de enlace (ruido térmico de UP-LINK, Ruido -- térmico de DOWN-LINK, Ruido por intermodulación del satélite y ruido de interferencia intrasistema).
- b) Ruido del equipo de la estación terrena (excluyendo Ruido Térmico generado en el receptor).
- c) Ruido de interferencia de otros sistemas (Ruido de interferencia de sistemas de radiorepetidoras de su superficie y de otros sistemas de satélite).

El ruido de enlace del inciso a) ocupa generalmente la parte mas grande de la potencia del ruido total en el circuito de referencia hipotético y está determinado por varios factores tales como el EIRP de la estación terrena, la $\frac{G}{T}$ de la estación terrena, el funcionamiento del transponder del satélite y el índice de modulación de la señal de F.M. Entre fuentes de -- ruido en el equipo de la estación terrena el ruido de intermodulación generado en el transmisor depende del tipo de amplificador y su método de operación. Este hecho necesita tomarse en -- cuenta cuando portadoras múltiples son amplificadas en un transmisor. Otras fuentes de ruido son diferentes tipos de ruido de intermodulación las cuales son inherentes a la transmisión de -- F.M. El ruido de interferencia debido a otros sistemas, incluye aquellos provenientes de sistemas de microondas de superficie -- y otros sistemas de satélite diferente al sistema tratado. En -- casos reales, la cantidad esperada de ruido de interferencia, difiere una gran cantidad dependiendo de la localización del satélite en la órbita geostacionaria y del medio geográfico alrededor de la estación terrena. Así, el problema de cuanta potencia de ruido de interferencia puede asignarse a un sistema por satélites tiene que ser examinado para los sistemas individuales.

Las normas del CCIR relacionan al nivel máximo permisible de interferencia de otros sistemas de satélite y de sistemas de radio por línea de vista son como se muestran en la tabla I.

2.2 PARAMETROS FUNDAMENTALES PARA EL DISEÑO DE ENLACES POR SATELITE

2.2.1) $\frac{C}{N}$, $\frac{C}{N_0}$ y $\frac{C}{T}$

Al diseñar un enlace por satélite, particularmente al calcular el ruido de enlace definido en la sección anterior, la relación entre el nivel de la potencia de la portadora y el nivel de la potencia de ruido, es uno de los parámetros más fundamentales.

Estas relaciones pueden expresarse en términos de $\frac{C}{N}$, $\frac{C}{N_0}$ ó $\frac{C}{T}$ que serán empleados de acuerdo a la situación, la interrelación entre esos parámetros es como sigue:

$$\frac{C}{N} = \frac{C}{KT B_0} \quad (1)$$

$$\left[\frac{C}{N_0} \right] = \left[\frac{C}{N} \right] + 10 \log B_0 \quad (2)$$

$$\left[\frac{C}{T} \right] = \left[\frac{C}{N_0} \right] + 10 \log K \quad (3)$$

Donde:

- C - Potencia de la portadora (W)
- N - Potencia de Ruido (W)
- K - Constante de Boltzman ($\frac{Jouls}{^\circ K}$)
- T - Temperatura de ruido (°K)

Limitaciones de ruido de interferencia para servicio de satélites
fijos en sistemas de satélites Geostacionarios (CCIR 1978)

SISTEMAS	RECOMENDACIONES DEL CCIR	POTENCIA DEL RUIDO DE INTERFERENCIA	PORCENTAJE DE TIEMPO DE CUALQUIER MES		N. O T A S
			PROMEDIO EN MINUTOS		
Interferencia entre redes de satélites geostacionarios en el servicio de satélites fijos.	REC. 466-2 ruido de interferencia (telefonía FDM-FM)	1,500 PWOP reuso de frecuencias 2,000 PWOP no reuso de frecuencias.	más del 20%	10 minutos	1 000 PWOP para redes que sometieron publicaciones avanzadas al IFRB antes de junio de 1978. inferiores a 10 GHz. Revisado en la asamblea del CCIR en 1980 a 600 PWOP
	en circuito hipotético de referencia.	400 PWOP de otra red			
	REC. 483-1 Ruido de interferencia (televisión FM) en el circuito hipotético de referencia.	1/10 del ruido de video permitido 4/10 del anterior de otra red	más del 1%		
Interferencia en un sistema de radio terrestre debido al servicio de sistemas de satélites fijos.	REC. 523 Nivel de potencia de interferencia total (PCM de 8 bits)	15% reuso de frecuencia 20% no reuso de frecuencia 4% de otra red del nivel de potencia de ruido total que daría lugar a BER de 1 en 10 ⁶	más del 20%	1 minuto	10% para las redes que sometieron publicaciones avanzadas al IFRB antes de junio de 1978. inferiores a 10 GHz valores provisionales
	REC. 357-3 ruido de interferencia (telefonía FDM-FM)	1,000 PWOP	más del 20%	1 minuto	
Interferencia en un sistema de radio terrestre debido al servicio de sistemas de satélites fijos.	en un circuito hipotético de referencia de 2500 Kms.	50000 pWop	más del 0.01%	1 minuto	superior a 1 GHz
Interferencia al servicio de un sistema de satélite fijo debido a sistemas de radio terrestres.	Rec. 356-4 ruido de interferencia (telefonía FDM-FM) en un circuito hipotético de referencia de servicio de satélite fijos.	1000 pWop	más del 20%	1 minuto	superior a 1GHz
		50,000 pWop	más del 0.03%		
Interferencia al servicio de un sistema de satélite fijo debido a sistemas de radio terrestres.	Rec. 558 potencia interferente (PCM de 8 bits)	10% de la potencia de ruido total que darían lugar a BER de 1 en 10 ⁶	más del 20%	10 minutos	valores provisionales
		BER no debe exceder de 1 en 10 ⁶	más del 0.03%	1 minuto	

TABLA 1

Limitaciones del ruido de interferencia para servicio de satélites fijos en sistemas de satélites Geoestacionarios (CCIR 1978)

SISTEMAS	RECOMENDACIONES DEL CCIR	POTENCIA DEL RUIDO DE INTERFERENCIA	PORCENTAJE DE TIEMPO DE CUALQUIER MES		NOTAS
			PROMEDIO EN MINUTOS		
<p>622</p> <p>Interferencia entre redes de satélites geoestacionarios en el servicio de satélites fijos.</p>	<p>REC. 466-2 ruido de interferencia (telefonía FDM-FM)</p> <p>en circuito hipotético de referencia.</p>	<p>1 500 PWOP : reuso de frecuencias</p> <p>2 000 PWOP : no reuso de frecuencias.</p> <p>400 PWOP : de otra red</p>	<p>más del 20%</p> <p>10 minutos</p>	<p>1 000 PWOP para redes que sometieron publicaciones avanzadas al IFRB antes de junio de 1978.</p> <p>Inferiores a 10 GHz</p> <p>Revisado en la asamblea del CCIR en 1980 a 600 PWOP</p>	
	<p>REC. 483-1 Ruido de interferencia (televisión FM) en el circuito hipotético de referencia.</p>	<p>1/10 del ruido de video permitido.</p> <p>4/10 del anterior : de otra red</p>	<p>más del 1%</p>		
	<p>REC. 523 Nivel de potencia de interferencia total (PCM de 8 bits)</p>	<p>15%: reuso de frecuencia.</p> <p>20%: no reuso de frecuencia</p> <p>4%: de otra red del nivel de potencia de ruido total que daría lugar a BER de 1 en 10⁶</p>	<p>más del 20%</p> <p>1 minuto</p>	<p>10% para las redes que sometieron publicaciones avanzadas al IFRB antes de junio de 1978.</p> <p>Inferiores a 10 GHz valores provisionales</p>	
	<p>REC. 357-3 ruido de interferencia (telefonía FDM-FM)</p>	<p>1,000pWop</p>	<p>más del 20%</p> <p>1 minuto</p>		
<p>Interferencia en un sistema de radio telex debido al servicio de sistemas de satélites fijos.</p>	<p>en un circuito hipotético de referencia de 2500 Kms.</p>	<p>50000pWop</p>	<p>más del 0.01%</p> <p>1 minuto</p>	<p>superior a 1 GHz</p>	
<p>Interferencia al servicio de un sistema de satélite fijo debido a sistemas de radio terrestres.</p>	<p>Rec.356-4 ruido de interferencia (telefonía FDM-FM) en un circuito hipotético de referencia de servicio de satélite fijo.</p>	<p>1000pWop</p>	<p>más del 20%</p> <p>1 minuto</p>	<p>superior a 1GHz</p>	
		<p>50,000 pWop</p>	<p>más del 0.03%</p>		
<p>621</p> <p>197</p>	<p>Rec.558 potencia interferente (PCM de 8 bits)</p>	<p>10% de la potencia de ruido total que darían lugar a BER de 1 en 10⁶</p>	<p>más del 20%</p> <p>10 minutos</p>	<p>valores provisionales</p>	
		<p>BER no debe exceder de 1 en 10⁴</p>	<p>más del 0.03%</p> <p>1 minuto</p>		

~~623~~
 B_0 - Ancho de Banda de la portadora ocupada.

$\left[\frac{C}{N} \right]$ - Razón de la potencia de la portadora a la potencia de ruido (db).
 (los paréntesis rectangulares implican expresiones en dbs).

$\left[\frac{C}{N_0} \right]$ - Razón de la potencia de portadora a la densidad de potencia de ruido (db.Hz).

$\left[\frac{C}{T} \right]$ - Razón de la potencia de portadora a la temperatura de ruido $\left(\frac{dbw}{^\circ K} \right)$.

$\left[\frac{C}{N} \right]$ - Es una expresión directa de ambas potencias de portadora y potencia de ruido -- que inmediatamente corresponden a valores medidos, pero contiene menos generalidad dado que su valor depende del ancho de banda del ruido. Por otro lado, $\left[\frac{C}{N_0} \right]$ y $\left[\frac{C}{T} \right]$ contiene generalidades dado que son independientes del ancho de banda del ruido y así son convenientes para la comparación entre portadoras que tienen valores diferentes de anchos de banda ocupados.

2.2 , 2) $\frac{S}{N}$. Cuando la potencia de portadora es suficientemente grande comparada con la potencia del ruido a la entrada de un demodulador de F.M., la potencia de ruido que aparece a la salida del demodulador que corresponde al ruido de entrada, es proporcional a la razón de la densidad de potencia de --

ruido a la potencia de portadora y al cuadrado de la desviación de frecuencia rms el cual está trayendo la portadora por el ruido de entrada. La potencia de ruido N_d a la salida del demodulador puede expresarse dentro de la gama de linealidad del demodulador de la siguiente manera.

$$N_d = a \cdot \frac{N_0}{C} \cdot f^2 \quad (4)$$

Donde:

N_0 - Es la densidad de potencia de ruido a la entrada del demodulador.

C - Potencia de portadora

f - Diferencia en frecuencia entre portadora y ruido.

a - Una constante relacionada a las características de funcionamiento del demodulador.

(Se supone aquí que una salida $a \cdot f_r^2$ es dada y que corresponde a una señal con una desviación de frecuencia r.m.s. f_r).

Cuando la potencia total del ruido está dentro de la banda $f_1 f_2$ después de la demodulación, es N_t ,

$$N_t = a \cdot \frac{N_0}{C} \int_{f_1}^{f_2} f^2 df$$

$$= \frac{a}{3} \cdot \frac{N_0}{C} (f_2^3 - f_1^3) \quad (5)$$

en el caso donde $f_2 \gg f_1$ la ecuación anterior puede simplificarse de la siguiente manera

$$N_t = \frac{a}{3} \cdot \frac{N_0}{C} \cdot f_2^3 \quad \text{--- (6)}$$

Por lo tanto, la razón de la potencia de la señal a la potencia de ruido en la salida del demodulador, está dada por la siguiente ecuación

$$\frac{S}{N} = 3 \frac{C}{N_0} \cdot \frac{1}{f_2} \left(\frac{f_r}{f_2} \right)^2 \quad \text{--- (7)}$$

Donde:

f_r - Desviación de frecuencia rms de la señal.

Aquí, $2 \times 3 \left(\frac{f_r}{f_2} \right)^2$ se llama la ganancia de ancho de banda debido al sistema F.M. la cual implica la razón de la anterior $\frac{S}{N}$ a la de la señal A.M. con 100% de modulación.

Cuando se considera un solo canal sobre un circuito telefónico multicanal, la potencia de ruido del canal N_{CH} se escribe de la siguiente manera:

$$N_{CH} = a \frac{N_0}{C} \int_{f_i - \frac{\Delta f}{2}}^{f_i + \frac{\Delta f}{2}} f^2 \Delta f$$

$$= \frac{a}{3} \frac{N_0}{C} \cdot \Delta f \left(3f_i^2 + \frac{\Delta f^2}{4} \right) \quad \text{--- (8)}$$

Donde:

f_i - Es la frecuencia central de un canal de interés.

Δf - Es el ancho de banda del canal.

En el caso donde $f_i \gg \Delta f$, ec. (8) puede simplificarse de la siguiente manera:

$$N_{CH} = a \cdot \frac{N_0}{C} \Delta f \cdot f_i^2 \quad (9)$$

Vemos de esta ecuación que la potencia de ruido del canal es proporcional al cuadrado de la frecuencia de banda base y por lo tanto tiende a ser máximo en el canal superior de la banda base.

De la ec. (9) la $\frac{S}{N}$ del canal está dada por:

$$\frac{S}{N} = \frac{C}{N_0} \cdot \frac{1}{\Delta f} \left(\frac{f_r}{f_i} \right)^2 \quad (10)$$

Donde

f_r - Desviación de frecuencia rms de la señal.

De la ecuación (10) la razón de la potencia de la señal de tono de prueba a la potencia de ruido ponderado en el canal superior de la banda base, toma en cuenta el mejoramiento por énfasis y el factor de ponderación es obtenido de la siguiente manera:

$$\left[\frac{S}{N_w} \right] = \left[\frac{C}{N_0} \right] - 10 \log b_{ch} + 20 \log \frac{f_r}{f_m} + [P] + [w] \quad (11)$$

Donde

$\left[\frac{S}{N_w} \right]_t$ - Es la razón de la potencia de la señal de tono de prueba a la potencia del ruido ponderado en el canal superior de banda base (db).

$\left[\frac{C}{N_0} \right]$ - La razón de la potencia de portadora a la densidad de potencia de ruido a la entrada del demodulador (db.H_z)

b_{CH} - Ancho de banda del canal (3100 H_z).

f_r - Desviación de frecuencia rms debida al tono de prueba de 0 dbm₀ (H_z)

f_m - Frecuencia máxima de banda base (H_z)

$[P]$ - Mejoramiento por énfasis (4db al canal superior de banda base).

$[w]$ - Factor de ponderación (2,5 db) (1)

De la ecuación (11) la potencia de ruido (ponderado ó cargado psfométricamente) al punto de nivel relativo "o" se obtiene de la siguiente manera:

$$10 \log N_w = 83.5 - \left[\frac{C}{N_0} \right] + 10 \log b_{CH} - 20 \log \left[\frac{f_r}{f_m} \right] \quad (12)$$

Donde:

N_w - Potencia de ruido cargado en el canal superior de la banda base en PW_{op}.

(1) Este factor representa el efecto del ruido sobre el oído humano generalmente se emplea un valor 2,5 db.

2.3 RUIDO DE ENLACE

El ruido de enlace como se definió anteriormente, consiste del ruido térmico del UP-LINK, el ruido térmico del DOWN LINK, el ruido de intermodulación del satélite y el ruido de interferencia intrasistema. La cantidad de ruido en cada categoría implica un valor equivalente del ruido después de la demodulación, el cual depende del $\frac{C}{N}$ y el índice de modulación de la señal de F.M. Puede expresarse convenientemente en términos de la potencia de ruido (ejemplo en pico watts) referido al punto de nivel relativo cero del circuito hipotético de referencia, si la respectiva $\frac{C}{N}$ que relaciona a las categorías anteriores y, la potencia de ruido de enlace total son conocidas.

2.3, 1.- RUIDO TERMICO DE UP-LINK o ASCENDENTE

La mayor fuente de ruido del UP-LINK es el ruido térmico generado en el receptor de satélite. Cuando se considera la contribución a la potencia del ruido después de la demodulación en una estación receptora terrena, es necesario definir la relación entre la potencia de ruido mencionado anteriormente y la potencia portadora. La $\frac{C}{N_0}$ del UP-LINK para una sola portadora está dada por

$$\left[\frac{C}{N_0} \right]_u = [P_E] - [L_u] + \left[\frac{G}{T} \right]_s - 10 \log K \quad (13)$$

Donde:

$$[P_E] - \text{EIRP de la estación terrena (dbw)}$$

$$[L_u] - \text{Pérdida de transmisión del UP-LINK (db)}$$

$$\left[\frac{G}{T} \right]_s - \text{La } \frac{G}{T} \text{ del satélite en (db}^\circ\text{K)}$$

K - Constante de Boltzman (10 log K =
- 228.6 db)

Cuando se considera la amplificación simultánea de portadoras múltiples, es necesario obtener una $\frac{C}{N_0}$ compuesta para el UP-LINK empleando la siguiente ecuación.

$$\left[\frac{C}{N_0} \right]_{uA} = [w_s] - 10 \log \frac{4\pi}{\lambda^2} - [Bo_i] + \left[\frac{G}{T} \right]_s - 10 \log K \quad (14)$$

Donde:

w_s - Densidad del flujo de potencia de entrada requerido para saturar un transponder del satélite (dbw/m²)

$10 \log \frac{4\pi}{\lambda^2}$ - Ganancia de una antena hipotética con un área efectiva de un m² para una longitud de onda de λ (db)

$[Bo_i]$ - Punto de operación (back-off) de entrada de un transponder del satélite (db)

$\left[\frac{G}{T} \right]_s$ - $\frac{G}{T}$ del satélite en (db°K)

Donde $[w_s] - 10 \log \frac{4\pi}{\lambda^2}$ se considera como la potencia, la cual puede derivarse del $\frac{4\pi}{\lambda^2}$ área efectiva unitaria de la antena cuando el transponder del satélite está saturado.

Bo_i - Implica la diferencia entre nivel de potencia de entrada de una sola portadora al cual hace que un transponder del satélite

esté saturado y la de un punto de operación real. Esta relación se ilustra en la fig.

(2)

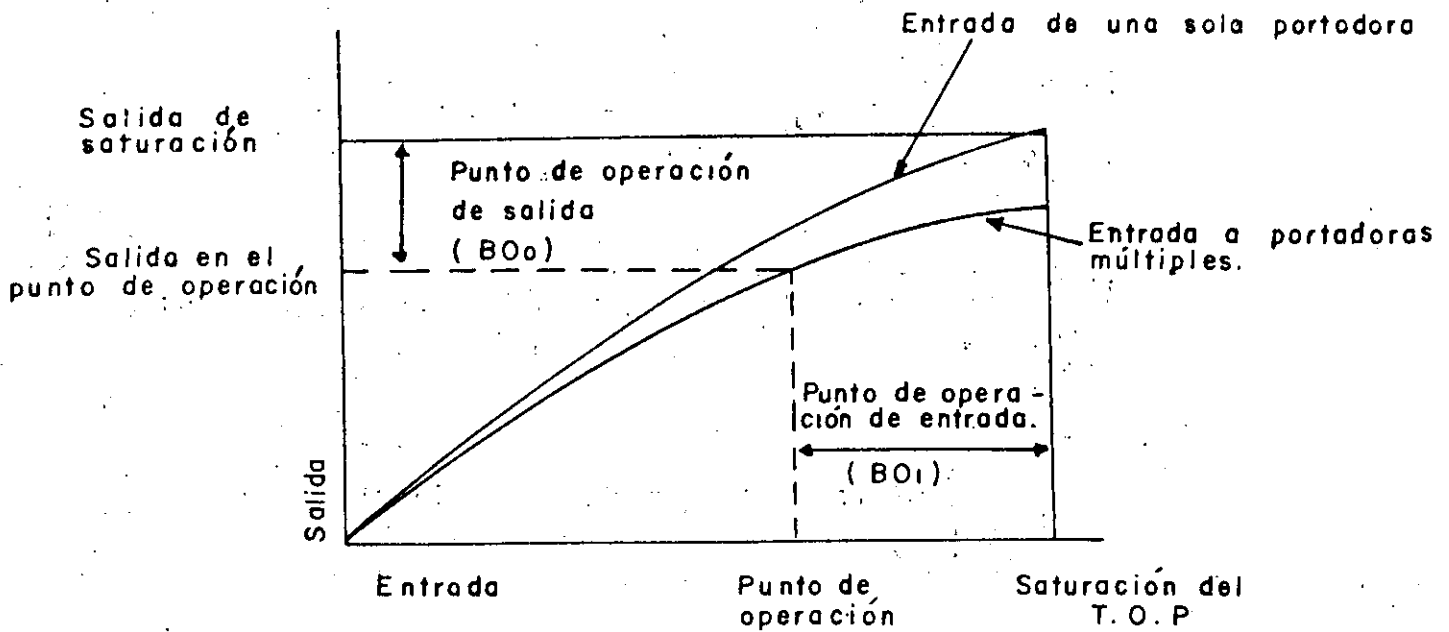


Fig.(2) Características entrada - salida de un amplificador de T.O.P.

2.3,2 RUIDO TERMICO DEL DOWN-LINK.

Dentro de la categoría del ruido térmico incluido en el DOWN-LINK, los dominantes son el ruido térmico recibido por la antena de la estación terrena y el generado en el receptor de la estación terrena. $\frac{C}{N_0}$ para una sola portadora y portadoras múltiples están dadas respectivamente por las siguientes ecuaciones:

$$\left[\frac{C}{N_0} \right]_d = \left[P_S \right] - \left[L_d \right] + \left[\frac{G}{T} \right]_E - 10 \log K \quad (15)$$

$$\left[\frac{C}{N_0} \right]_A = \left[P_{SM} \right] - \left[BO_0 \right] - \left[L_d \right] + \left[\frac{G}{T} \right]_E - 10 \log K \quad (16)$$

Donde:

$\left[P_S \right]$ - EIRP del satélite de una sola portadora - (dbw)

$\left[L_d \right]$ - Pérdida de transmisión del DOWN-LINK (db)

$\left[\frac{G}{T} \right]_E$ - $\frac{G}{T}$ de la estación terrena (db°K)

$\left[P_{SM} \right]$ - La EIRP de saturación del satélite para una sola portadora (dbw).

$\left[BO_0 \right]$ - Punto de operación (back-off) de salida de un transponder del satélite en (db).

2.3,3.- RUIDO DE INTERMODULACION DEL SATELITE

Los amplificadores de TOP son generalmente empleados como transponders del satélite. Cuando portadoras múltiples son amplificadas en un transponder simultáneamente, un conjunto de productos de intermodulación formados por combinaciones de estas portadoras, las cuales se llevan a cabo debido a la no linealidad de amplitud y fase del amplificador TOP, viene a ser una fuente de ruido en la banda de frecuencias de transmisión de las señales de R.F.

La cantidad de ruido de intermodulación varía dependiendo de la combinación de portadoras, las cuales son amplificadas simultáneamente y de la posición relativa de la portadora de interés sobre una escala de frecuencias.

Así, es difícil expresarlo en una forma general. Además, el ruido de intermodulación contiene componentes las cuales tienen correlación con señales de R.F. en sus fases, y esto prohíbe el manejo del ruido de intermodulación de la misma manera que el ruido térmico. Al diseñar un enlace por satélite generalmente ^{se} emplean valores experimentales para determinar el objetivo de ruido de intermodulación.

Si la razón de la salida de saturación de un transponder a la potencia de ruido de intermodulación cae dentro de la banda de frecuencia de transmisión es obtenido experimentalmente, la $\frac{C}{N_0}$ que relaciona la portadora puede expresarse de la siguiente manera.

$$\left[\frac{C}{N_0} \right]_{IM} = \left[\frac{C_S}{N_0} \right]_{IM} + \left[P_S \right] - \left[P_{SM} \right] \quad (17)$$

Donde

$\left[\begin{array}{c} C_S \\ No \end{array} \right]_{IM}$	-----	Razón de la EIRP de saturación de un transponder al ruido de intermodulación ¹ por H_z a un punto de operación de una portadora de interés (db)
$\left[P_S \right]$	-----	EIRP del satélite para una portadora de interés en (dbw)
$\left[P_{SM} \right]$	-----	EIRP de saturación de un transponder en (dbw)

2.3 ,4. INTERFERENCIA INTRASISTEMA

Para la utilización eficiente del espectro de frecuencias localizado en el servicio de satélites fijos, el reuso de frecuencias es disponible por medio de aislamiento del haz del satélite o por medio del aislamiento de polarización.

Estas técnicas sin embargo traen otra fuente de ruido a una portadora cocanal. Además en el caso donde las frecuencias de las portadoras adyacentes con la misma polarización en el mismo haz no están suficientemente separadas o las características de atenuación del filtro pasabanda en un transponder no son satisfactorios, la interferencia mutua entre estas portadoras no puede despreciarse.

Dado que en general el ruido de interferencia tiene una distribución en el espectro no plano no puede tratarse de la misma manera que el ruido térmico. Sin embargo puede transformarse dentro de un equivalente del ruido térmico basado sobre -

¹El ruido de intermodulación por H_z transformado desde un valor medido de intermodulación que en la banda de frecuencias de interés.
cae

un valor experimental.

Considérese un caso donde las dos fuentes de interferencia mencionadas anteriormente existen en ambas trayectorias del enlace el UP-LINK y DOWN-LINK. Cuando estas fuentes de interferencia individuales no están correlacionadas una con otra la interferencia total está dada por la siguiente expresión.

$$\frac{1}{\left(\frac{C}{N_o}\right)_1} = \frac{1}{\left(\frac{C}{N_o}\right)_{BU}} + \frac{1}{\left(\frac{C}{N_o}\right)_{Bd}} + \frac{1}{\left(\frac{C}{N_o}\right)_{XU}} + \frac{1}{\left(\frac{C}{N_o}\right)_{Xd}} \quad (18)$$

Donde:

$\left(\frac{C}{N_o}\right)_{BU}$ ----- Es $\frac{C}{N_o}$ equivalente debido a la interferencia en el UP-LINK debido al cubrimiento, de la misma polarización.

$\left(\frac{C}{N_o}\right)_{Bd}$ ----- Es $\frac{C}{N_o}$ equivalente debido a la interferencia en el DOWN-LINK debido al cubrimiento de la misma polarización.

$\left(\frac{C}{N_o}\right)_{XU}$ ----- $\frac{C}{N_o}$ equivalente debido a la interferencia en el UP-LINK debido al cubrimiento de la polarización opuesta.

$\left(\frac{C}{N_o}\right)_{Xd}$ ----- $\frac{C}{N_o}$ equivalente debido a la interferencia en el DOWN-LINK debido al cubrimiento de la polarización opuesta.

Debe observarse que todos los valores para $\frac{C}{N_o}$ en la ecuación (18) son expresados en valores antilogarítmicos.

2.3.5. RUIDO DE ENLACE TOTAL.

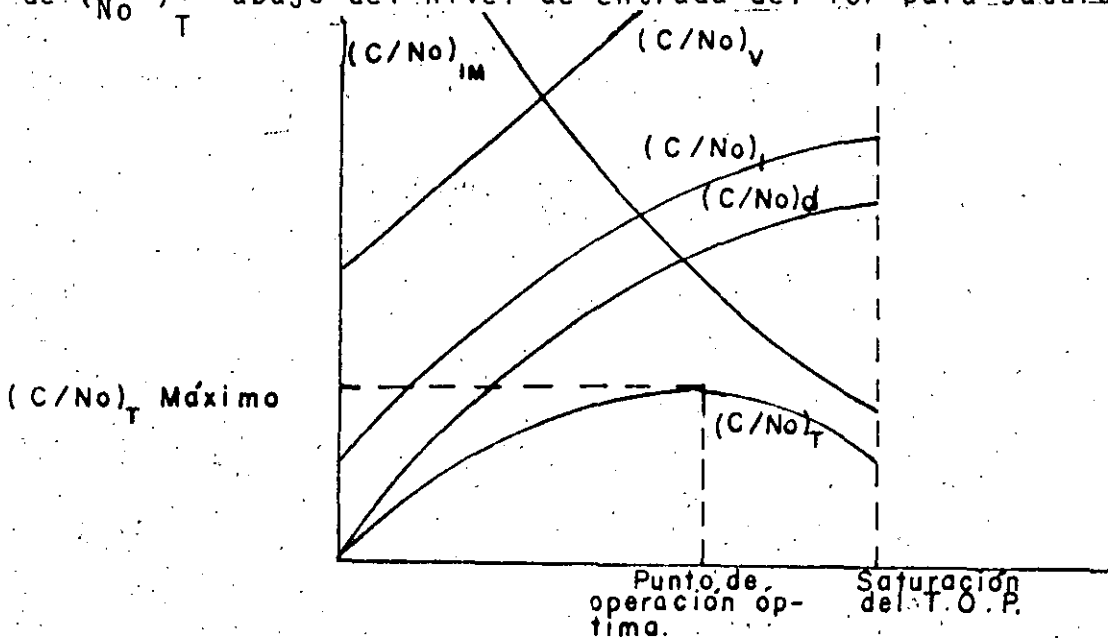
Dado que las fuentes de ruido individuales descritas en los puntos del 1 al 4 pueden considerarse que no están correlacionadas una con otra, el recíproco del total $\frac{C}{N_o}$ (la razón de la potencia de ruido total a la potencia portadora) es igual a la suma de los recíprocos individuales de $\frac{C}{N_o}$.

Nominalmente

$$\frac{1}{\left(\frac{C}{N_o}\right)_T} = \frac{1}{\left(\frac{C}{N_o}\right)_U} + \frac{1}{\left(\frac{C}{N_o}\right)_d} + \frac{1}{\left(\frac{C}{N_o}\right)_{IM}} + \frac{1}{\left(\frac{C}{N_o}\right)_I} \quad (19)$$

Donde todos los valores de $\frac{C}{N_o}$ son antilogarítmicos.

La figura (3) muestra la relación entre el $\frac{C}{N_o}$ individual y $\left(\frac{C}{N_o}\right)_T$. Como se ve de la figura existe un punto máximo de $\left(\frac{C}{N_o}\right)_T$ abajo del nivel de entrada del TOP para saturación.



Nivel relativo del punto de operación del T.O.P. (dB)

Fig.(3) Relación entre el punto de operación del T.O.P. del transponder de B.S. y $\frac{C}{N_o}$.

2.3,6. MARGEN DE UMBRAL.

Cuando el $\frac{C}{N_0}$ en la entrada del demodulador de F.M. es suficientemente grande, la $\frac{S}{N}$ a la salida es proporcional a la $\frac{C}{N_0}$. Sin embargo, si la $\frac{C}{N_0}$ disminuye abajo de un cierto nivel, la $\frac{S}{N}$ no mantiene la relación 1 a 1 y se deteriora rápidamente como se observa en la fig. 4.

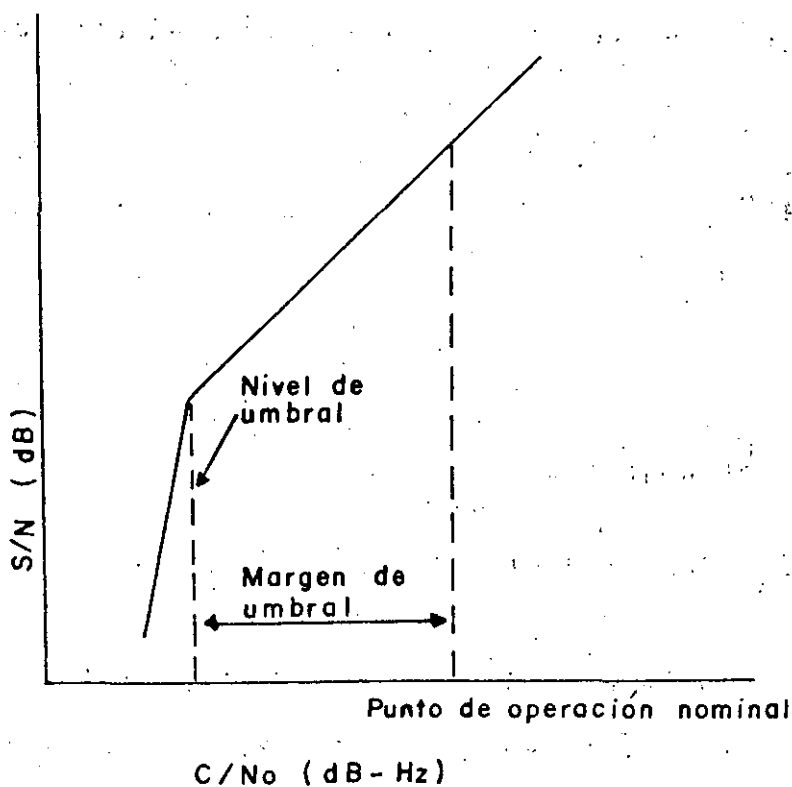


Fig.(4) Umbral en sistemas de F.M.

637

Este nivel de entrada es generalmente llamado el nivel de umbral. No obstante en un tipo convencional de demodulador, el fenómeno de umbral ocurre a una $\frac{C}{N}$ de aproximadamente -10db, el nivel de umbral puede reducirse por varios decibeles si se emplea un demodulador de extensión de umbral.

En el enlace por satélites, el sistema es generalmente operado a una $\frac{C}{N_0}$ mayor por varios decibeles que el nivel de umbral. La diferencia entre el $\frac{C}{N_0}$ del punto de operación nominal y la del nivel de umbral es llamado el margen del umbral.

Suponiendo que el nivel de umbral aparece a una $\frac{C}{N}$ de 10 db, el margen de umbral está dado por la siguiente expresión

$$\left[E \right] = \left[\frac{C}{N_0} \right]_{OP} - 10 \log B_0 - 10 \quad (20)$$

$$B_0 = 2fr \cdot \ell \cdot g + 2 f_m$$

Donde:

$\left[E \right]$ - margen de umbral en (db)

$\left[\frac{C}{N_0} \right]_{OP}$ Es el $\frac{C}{N_0}$ en el punto de operación (db·Hz).

B_0 - Ancho de banda ocupado por una señal de F.M. en Hz

f_r - Desviación de frecuencia r.m.s. del tono de prueba (Hz)

ℓ - Factor de carga

g - Factor pico

f_m - Frecuencia superior de la banda base en (Hz)

Cuando se usa un demodulador de extensión de umbral, el factor de mejoramiento debe de sumarse al margen de umbral dado

por la ecuación 20. Factores de variación en propagación incluye atenuación por precipitación (acompañada por un incremento de ruido térmico), desvanecimiento por cintilleo. En regiones que tienen mucha lluvia, la influencia de atenuación por precipitación y su incremento acompañado de ruido térmico es más significativa.

Por esta razón, el margen previsto para un punto de operación nominal arriba del nivel de umbral algunas veces es llamado margen de lluvia, el cual se aplica únicamente al DOWN-LINK.

La relación entre el margen de umbral y el margen de lluvia se expresa como

$$[E] = 10 \log \left[\frac{N_T + (m+1)N_d}{N_T} \right] \quad (21)$$

$$[M] = 10 \log m \quad (22)$$

Donde

$[E]$ = margen de umbral (db)

$[M]$ = margen de lluvia (db)

m = valor del incremento del ruido térmico del DOWN-LINK, debido a la precipitación

N_T = ruido de enlace total bajo una condición normal (cielo despejado) (PWOp)

N_d = ruido térmico del DOWN-LINK bajo una condición normal (cielo despejado) (PWOp)

2.4 RUIDO DEL EQUIPO DE LA ESTACION TERRENA

Entre varias fuentes de ruido en el equipo de la estación terrena, el ruido térmico generado en el receptor ha sido manejado como una componente del ruido de enlace como se describió en la sección anterior. En esta sección se discutirá el ruido del equipo de la estación terrena excluyendo el ruido térmico en un receptor. Las fuentes de ruido principales en esta categoría son el ruido de intermodulación debido a los amplificadores de alta potencia de la estación terrena y el ruido de intermodulación generado en una línea de transmisión de F.M. El ruido térmico que excluye la del receptor y el ruido de intermodulación debido al receptor también se incluye en esta categoría.

En el sistema intelsat los objetivos empleados se muestran en la tabla II.

T A B L A I I

Ruido del Equipo de la Estación Terrena en el Sistema INTELSAT

TIPO DE RUIDO	POTENCIA DE RUIDO P_{WO} p
- Ruido de intermodulación debido a amplificadores de alta potencia ¹	500
- Ruido de distorsión por retardo de grupo del transmisor	200
- Ruido por distorsión por retardo de grupo del receptor	200
- Ruido del transmisor que excluye el anterior	250
- Ruido del receptor que excluye el anterior ²	250
- Ruido por distorsión del retardo del grupo dentro del satélite ³	100

¹Incluyendo contribuciones de imisiones fuera de banda debido a intermodulación de otras estaciones terrenas.

²Excluyendo ruido térmico del receptor.

³Será aplicada después de la compensación de la estación terrena de la transmisión lateral.

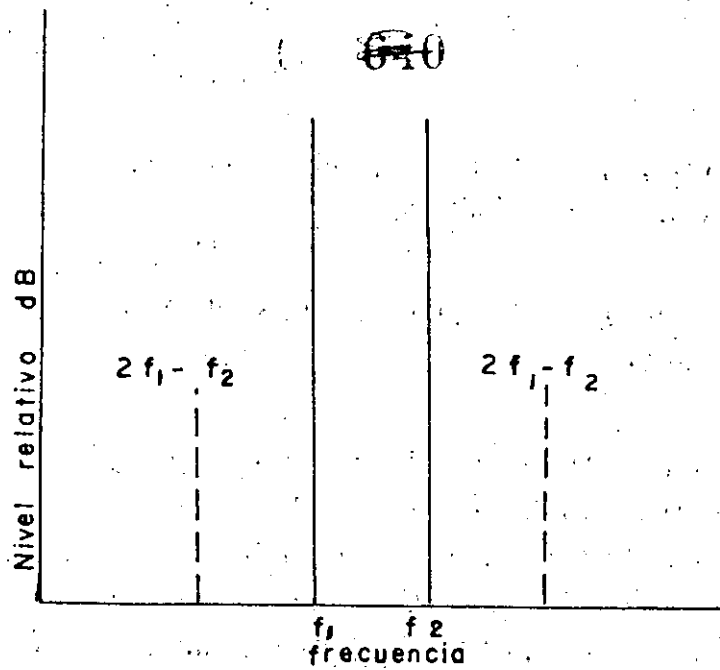


Fig.(5) Productos de intermodulación de tercer orden para el caso de dos portadoras.

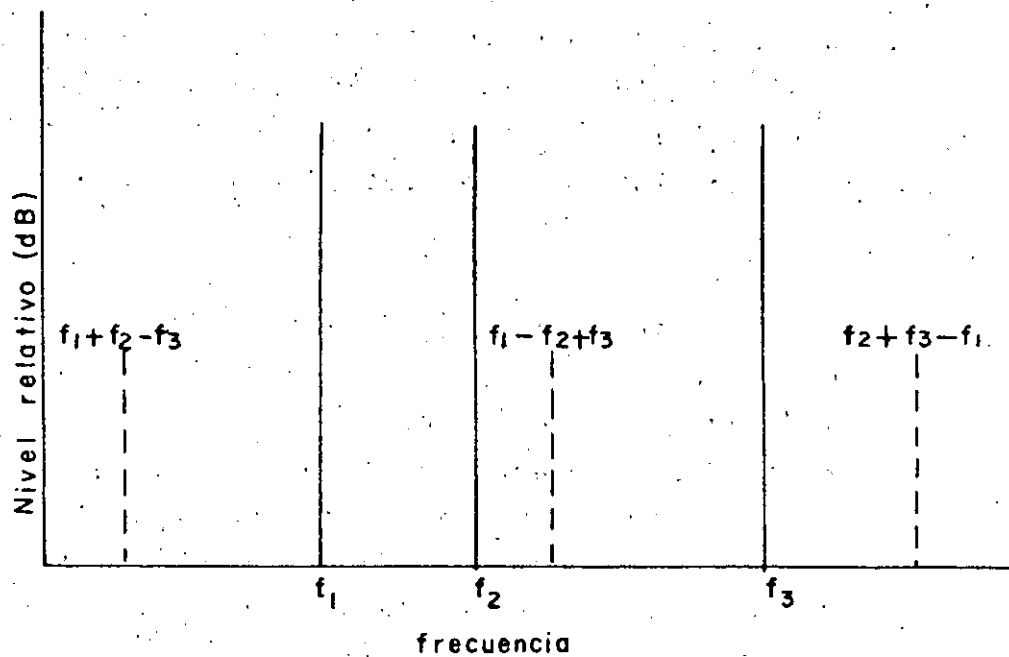


Fig.(6) Productos de intermodulación de tercer orden para el caso de tres portadoras.

641

La profundidad de cada objetivo se deja en manos del diseñador de la estación terrena.

2.4.1. RUIDO DE INTERMODULACION DEBIDO A UN AMPLIFICADOR DE ALTA POTENCIA.

Los amplificadores de alta potencia de las estaciones terrenas, generalmente consisten de tubos Klystron, ó TOP los cuales tienen características entrada salida no lineales. Por lo tanto cuando más de una portadora son amplificadas simultáneamente en dicho amplificador, los productos de intermodulación tienden a ser producidos por una combinación de estas portadoras igualmente caen en la banda de frecuencia de transmisión y vienen a ser una fuente de ruido.

Entre los productos de intermodulación el más significativo es el de tercer orden. Los tipos de $(2f_1 - f_2)$ y $(2f_2 - f_1)$ como las combinaciones de dos portadoras y los tipos de $(f_1 + f_2 - f_3)$, $(f_1 - f_2 + f_3)$ y $(f_2 + f_3 - f_1)$ como las combinaciones de 3 portadoras que pueden caer dentro de la banda de frecuencias de transmisión, donde f_1, f_2 y f_3 son las frecuencias portadoras. Las figuras (5) y (6) ilustran ejemplos de productos de intermodulación para los casos de dos y tres portadoras respectivamente.

Las características de intermodulación de KLYSTRON y TOP generalmente se expresan en términos de la cantidad de productos de intermodulación de tercer orden, los cuales son generados cuando dos portadoras no moduladas de igual amplitud son amplificadas simultáneamente. Basado en esto, los productos de intermodulación de tercer orden para los casos de dos y tres portadoras cada una no modulada y de una amplitud diferente, se obtienen de la siguiente expresión

$$[P_{1M}]_2 = [P_1] + [P_2] - 2[P_0] + [P_{1M}] \quad (23)$$

$$[P_{1M}]_3 = [P_1] + [P_2] + [P_3] - 3[P_0] + [P_{1M}] + .6 \dots \dots \dots (24)$$

Donde:

$[P_{1M}]_2$	Productos de intermodulación de tercer orden, para el caso de dos portadoras (dbW)
$[P_{1M}]_3$	Productos de intermodulación de tercer orden para el caso de tres portadoras (dbW)
$[P_1], [P_2], [P_3]$	Potencias de portadoras simultáneamente amplificadas (dbW)
$[P_0]$	Potencia de las portadoras de referencia las cuales dan los productos de intermodulación de dos portadoras no moduladas de igual amplitud (dbW)
$[P_{1M}]$	Productos de intermodulación para el caso de dos portadoras de referencia de igual amplitud (dbW)

Debe notarse que en casos reales, no hay necesidad de considerar los productos de intermodulación de alto orden mayores que el tercero, pero deben tomarse en cuenta cuando se quiere un análisis preciso.

Los productos de intermodulación debido a las portadoras moduladas en frecuencia forman una envolvente compleja de acuerdo a las distribuciones de espectro individual.

Cuando el espectro de las portadoras de F.M. son distribuidas por señales dispersas de energía, los productos de intermodulación por ancho de banda de frecuencia unitaria se reducen en proporción al efecto de la energía dispersa.

2.4.2. RUIDO DE INTERMODULACION DEBIDO A LINEAS DE TRANSMISION DE F.M.

Sobre una línea de transmisión de F.M., el ruido de intermodulación es originado por la no linealidad entrada salida, no linealidad de características fase-frecuencia, características amplitud frecuencia y eco. Dado que el ruido por intermodulación debido a estos factores se discuten en detalle en -- otras publicaciones aquí únicamente se indican ecuaciones para calcular dicho ruido las cuales aparecen en la tabla(III). El ruido de intermodulación en esta categoría es generalmente medido por medio de métodos de carga de ruido. La potencia de ruido Pesado debido a la intermodulación referido al punto del nivel relativo cero puede derivarse de la razón del nivel de carga de ruido al nivel de ruido de intermodulación de la siguiente manera.

$$10 \log N = 90 - \left[\frac{S}{D} \right] - 10 \log n + 20 \log \frac{\sigma}{f_r} - 10 \log \frac{b_{\ell}}{b_{ch}} - [P_d] - [W] \quad (25)$$

Donde:

N - Ruido de intermodulación cargado (PWop)

$\frac{S}{D}$ - Razón del nivel de la carga del ruido al ruido de intermodulación de segundo y tercer orden en un canal de interés (db)

n - Número de canales de señales de telefonía multicanalizadas

$\frac{\sigma}{f_r}$ - Razón de la desviación de frecuencia r.ms. de las señales telefónicas multicanalizadas a desviación de frecuencia del tono de prueba r.ms. ($20 \log \frac{\sigma}{f_r}$: nivel de carga de circuitos telefónicos multicanales)

$1 - 15 + 10 \log n$ (db) ($n > 240$), $-1 + 4 \log n$ (db) ($12 < n < 240$)

~~641~~

635

- b_{ℓ} - Ancho de banda de frecuencia en método de carga de ruido (4KHz)
- b_{ch} - Ancho de banda de un canal telefónico (3.1 KHz)
- $[P_d]$ - Mejoramiento² de características de ruido de intermodulación por medio de énfasis (db)
- $[w]$ - Factor de peso o de ponderación (2.5db)

² El mejoramiento en la $\frac{S}{N}$ por medio de énfasis referente al ruido de intermodulación de segundo y tercer orden en la parte superior del canal de banda base es aproximadamente 5.5 db y 3.5 db respectivamente.

645

636

T A B L A I I I

E C U A C I O N E S P A R A C A L C U L A R R U I D O D E I N T E R M O D U L A C I O N

Categoría de Distorsión	Ecuación	Notas
DISTORSION NO LINEAL	$\left[\frac{S}{D_2} \right] = -10 \log \left\{ \frac{1}{2} \left(\frac{d_1}{100} \right)^2 \alpha^2 \left(1 - \frac{1}{2} Kf \right) \right\}$ $\left[\frac{S}{D_3} \right] = -10 \log \left\{ \frac{1}{2} \left(\frac{d_2}{100} \right)^2 \alpha^2 \left(1 - \frac{1}{3} Kf^2 \right) \right\}$ $\left[\frac{S}{D_2} \right] \cdot \left[\frac{S}{D_3} \right]$ <p>Razón del nivel de carga de ruido de un canal de interés al ruido de intermodulación debido a componentes lineales y parabólico en db.</p> <p>d_1 - Componentes lineales de características de ganancia diferencial (%/Hz)</p> <p>d_2 - Componentes parabólicos de características de ganancia diferencial (%/Hz²)</p> <p>α - Desviación de frecuencia r.m.s. de señales telefónicas multicanales (Hz)</p> <p>Kf - Razón de la frecuencia de banda base superior f_m a la frecuencia central de un canal de interés f_i ($Kf = f_i/f_m$)</p>	<p>Debido a la no linealidad entrada salida del modulador, demodulador, etc.</p>
	$\left[\frac{S}{D_2} \right] = -10 \log \left\{ 2\pi^2 b_1^2 \alpha^2 f_i^2 \left(1 - \frac{1}{2} Kf \right) \right\}$ $\left[\frac{S}{D_3} \right] = -10 \log \left\{ 2\pi^2 b_2^2 \alpha^4 f_i^3 \left(1 - \frac{1}{3} Kf^2 \right) \right\}$ <p>b_1 - Componentes lineales de características de retardo ($\frac{s}{Hz}$)</p>	<p>Debido a las características fase frecuencia de una línea de transmisión de F.M. incluyendo amplificadores de F.I.</p>

	<p>b_2 - Componentes parabólicos de características de retardo $\left(\frac{S}{Hz^2}\right)$</p> <p>$f_i$ - La frecuencia central de un canal de interés (Hz)</p>	
distorsión de amplitud	<p>$\left[\frac{S}{D_2}\right] = -10 \log \left\{ \frac{1}{2} \left(\frac{Dg_1}{100}\right)^2 \alpha^2 \left(\frac{f_m}{f_d}\right)^4 Kf^4 \left(1 - \frac{1}{2} Kf\right) \right\}$</p> <p>$\left[\frac{S}{D_3}\right] = -10 \log \left\{ \frac{1}{2} \left(\frac{Dg_2}{100}\right)^2 \alpha^4 \left(\frac{f_m}{f_d}\right)^4 Kf^4 \left(1 - \frac{1}{3} Kf\right) \right\}$</p> <p>$Dg_1$ - Componente lineal de ganancia diferencial (%Hz)</p> <p>Dg_2 - Componente parabólica de ganancia diferencial (%Hz²)</p> <p>f_m - frecuencia superior de banda base (Hz)</p> <p>f_d - frecuencia diferencial (Hz)</p>	<p>Principalmente debido a coeficientes de 3° y 4° orden de características frecuencia amplitud de líneas de transmisión de FM. este factor debe considerarse para el caso de la transmisión de FM de una portadora de gran tamaño arriba de 1000 canales.</p>
distorsión por ECO	<p>$\left[\frac{S}{D_2}\right] = -10 \log \left\{ 8\pi^4 r_g^2 \tau^4 \alpha^2 f_i^2 \left(1 - \frac{1}{2} Kf\right) \right\}$</p> <p>$\left[\frac{S}{D_3}\right] = -10 \log \left\{ 8\pi^6 r_p^2 \tau^6 \alpha^4 f_i^2 \left(1 - \frac{1}{3} Kf\right) \right\}$</p> <p>$r_g = r \sin \omega_c \tau$, $r_p = r \cos \omega_c \tau$</p> <p>$r = \frac{r_1 r_2 e^{-2\alpha \tau}}{1 - r_1 r_2 e^{-2\alpha \tau}}$, $\tau = 2\ell/v$</p> <p>r - razón de eco (razón de amplitud de la señal principal a la señal reflejada)</p> <p>ω_c - frecuencia angular de la señal principal (rad/S)</p> <p>τ - retardo de tiempo entre la señal principal y señales reflejadas (S)</p> <p>r_1, r_2 - Coeficiente de reflexión en los puntos de entrada y salida</p>	<p>Debido al traslapamiento de la señal principal y la señal reflejada generada debido al desacoplamiento de impedancias en los puntos de entrada y salida de una línea de transmisión dentro de la estación terrena (ejemplo cable de FI, sistema de guías de onda, etc.)</p> <p>Las ecuaciones que se muestran en la columna central se aplican al caso donde el ancho de banda ocupado Bf de una señal telefónica multicanal y tiempo de retardo τ entre las señales principal y reflejadas tienen una relación de $Bf \tau < 1$</p>

α	- constante de atenuación de la línea de transmisión de interés
l	- longitud de la línea de interés (m)
v	- velocidad de propagación (m/S).

2.4.3.- RUIDO TERMICO.

No obstante que el ruido térmico en el receptor es el más dominante sobre todas las otras fuentes de ruido térmico dentro del equipo de una estación terrena, generalmente se maneja en forma separada como un factor componente del ruido térmico de down-link. Bajo esta categoría, por lo tanto se considera el ruido térmico debido al equipo de la estación terrena a excepción del receptor. Sin embargo la fuente de ruido térmico dominante está determinada por el diagrama de niveles de cada estación terrena.

2.4.4.- RUIDO DE INTERMODULACION DEBIDO AL RECEPTOR.

Esta fuente de ruido no es tan significativa como en el equipo transmisor. Sin embargo, cuando portadoras múltiples que incluyen una portadora de gran tamaño que maneje 1872 canales que son simultáneamente amplificados, debe considerarse el ruido de intermodulación debido a las características no lineales entrada-salida.

2.4.5.- RUIDO POR DISTORSION DE RETARDO DENTRO DE UN SATELITE.

Las características de retardo en los transponders de un satélite puede compensarse para una cierta magnitud en la estación terrena en el transmisor basado en datos obtenidos por mediciones. Las características de retardo residual después de la compensación y el efecto de las señales de paso debido a las características fuera de banda de transponders adyacentes (considerados equivalentes a las características de retardo) son incluidos en algunos ca

tos en la fuente de ruido del equipo de la estación terrena por conveniencia.

2.5 RUIDO DE INTERFERENCIA DE OTROS SISTEMAS.

Bajo esta categoría, se considera el ruido de interferencia de sistemas repetidores de radio terrestres y otros sistemas de satélite que comparten las mismas bandas de frecuencia. El ruido de interferencia debido al reuso de frecuencia dentro de un solo sistema, el ruido de interferencia de canal adyacente, y el ruido de distorsión de eco debido a una larga línea de transmisión puede manejarse de la misma manera que el ruido de interferencia de otros sistemas, no obstante estas fuentes de ruido se clasifican dentro de otras categorías para el propósito del cálculo del ruido.

El ruido de interferencia es manejado generalmente de muchas maneras de acuerdo a distribuciones de espectro de señales deseadas y no deseadas. Si se conoce la razón de potencia de las portadoras deseadas y las no deseadas, así como el factor de reducción de interferencia, la potencia de ruido de interferencia (pesado) se obtiene por la siguiente ecuación

$$10 \log N_p = 90 - \left[\frac{D}{U} \right] - [R_i] - [W] \quad (26)$$

Donde:

N_p - Potencia de ruido de interferencia (pesado) (PWop)

$\left[\frac{D}{U} \right]$ - Razón de la potencia de portadora deseada a la potencia de la portadora no deseada en la entrada del receptor (db)

$[R_i]$ - Factor de reducción de interferencia (db)

$$\left([R_i] = \left[\frac{S}{N_i} \right] - \left[\frac{D}{U} \right] \right)$$

$\left[\frac{S}{N_i} \right]$ - Razón de la potencia del tono de prueba (imw) a la poten--

cia de ruido de interferencia (no pesado) en un canal telefónico (ancho de banda 3.1 KHz) (db)

W - Factor de ponderación o de peso (2.5 db)

Cuando las portadoras deseadas y no deseadas son ambas señales F.D.M. - F.M. el factor de reducción de interferencia puede obtenerse de acuerdo a los índices de modulación de las dos portadoras como se dá a continuación.

a) Interferencia entre señales F.D.M.-F.M. con altos índices de modulación¹

$$\begin{aligned} [Ri] &= 10 \log \alpha_s - 10 \log b_{ch} + 20 \log \left(\frac{f_r}{f_i} \right) + 10 \log 2\sqrt{2\pi} \\ &- 10 \log \left\{ e^{-\frac{(F_o - f_i)^2}{2\alpha_s^2}} + e^{-\frac{(F_o + f_i)^2}{2\alpha_s^2}} \right\} + [P] \end{aligned} \quad (27)$$

DONDE:

$\alpha_s = \sqrt{\alpha_D^2 + \alpha_U^2}$ (α_D, α_U) - Desviación de frecuencia r.m.s. de las portadoras deseada y no deseada debido a las señales de telefonía multicanal (Hz)

b_{ch} - Ancho de banda de un canal telefónico (3100 Hz)

f_r - Desviación del tono de prueba r.m.s. de la portadora deseada (Hz)

f_i - Frecuencia central de un canal de interés (Hz)

F_o - Diferencia en frecuencia entre las portadoras deseada y no deseada (Hz)

$[P]$ - Mejoramiento por énfasis (db)

¹ Esta ecuación puede aplicarse cuando $\alpha/f_m > 1$ para ambas portadoras deseada y no deseada. Aquí α es la desviación de frecuencia r.m.s. debido a las señales de telefonía multicanal y f_m es la frecuencia máxima de banda base.

- b) Interferencia de una portadora F.D.M. - F.M. con un bajo índice de modulación dentro de una portadora F.D.M.-F.M. con un alto índice de modulación

$$\begin{aligned}
 [R_i] &= 10 \log \sigma_D - 10 \log b_{ch} + 20 \log \left(\frac{f_r}{f_i} \right) + 10 \log 2\sqrt{2\pi} \\
 &- 10 \log \left\{ e^{-\frac{(F_0 - f_i)^2}{2\sigma_D^2}} + e^{-\frac{(F_0 + f_i)^2}{2\sigma_D^2}} \right\} + [P] \quad (28)
 \end{aligned}$$

DONDE:

σ_D - es la desviación de frecuencia r.m.s. de la portadora - deseada debido a una señal de telefonía multicanal.

3 EJEMPLO DE UN DISEÑO DEL SISTEMA INTELSAT- IV- A

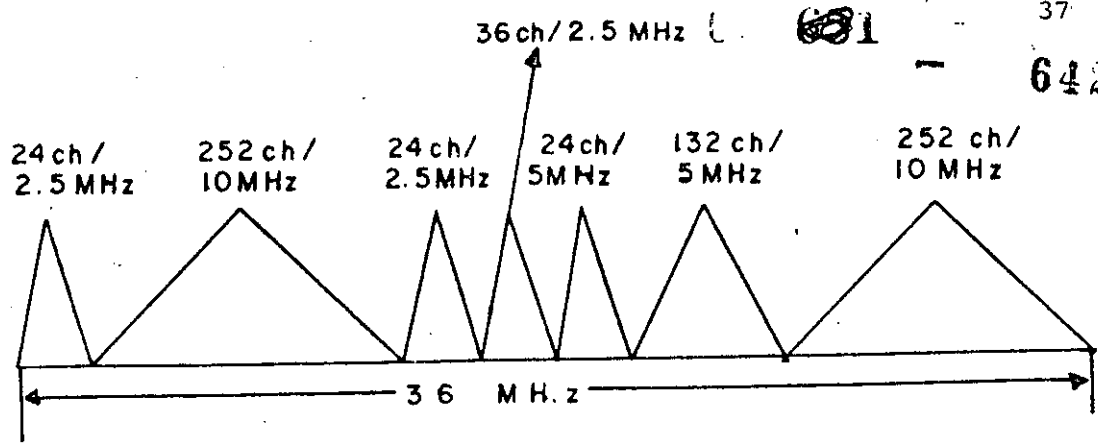
Un satélite INTELSAT IV-A tiene tres tipos de antenas - transmisoras del tipo haz; a saber:

- Haz Global
- Haz Hemisférico
- Haz Puntual²

En el caso del haz hemifésrico (ó haz puntual) se practica el reuso de frecuencias entre los haces este y oeste. Por lo tanto, en el diseño de enlaces por satélite para el sistema INTELSAT IV-A, el ruido de interferencia intrasistema tiene que considerarse como una componente para el ruido del enlace. Con el fin de reducir el ruido de interferencia intrasistema, se emplea un esquema intercalado de frecuencias, en el cual las frecuencias centrales de las portadoras de ambos haces este oeste están desviados uno con respecto a otro. Actualmente han sido diseñados sistemas de tal forma que la contribución al ruido - por la interferencia intrasistema viene a ser menor que aproximadamente 1000 p_{wop}. La figura (7) muestra un ejemplo del plan de frecuencias en el sistema INTELSAT IV-A.

²En el caso de una antena receptora se emplean dos tipos de haces - el global y el Hemisférico.

Transponder para el haz oeste



Transponder para el haz este

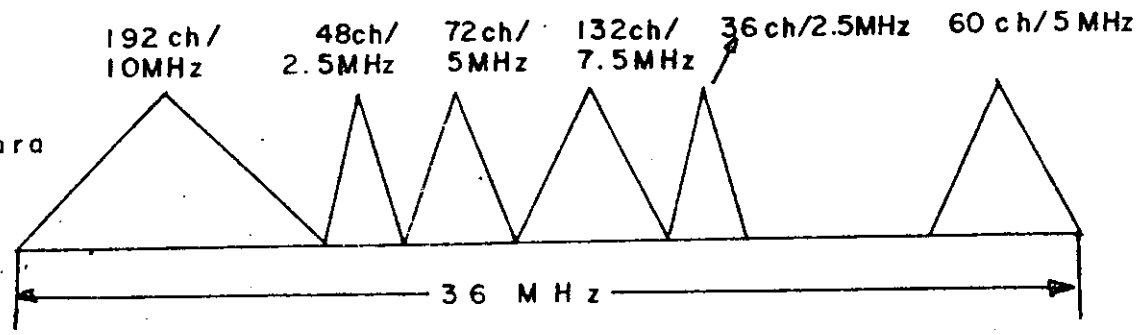


Fig.(7) Ejemplo de un arreglo en frecuencia aplicado al sistema del satélite INTELSAT IV-A con una interrelación combinada de frecuencia.

En la figura (8) se ilustra el incremento del factor de reducción de interferencia debido a la distribución intercalada de frecuencias, el cual se ha calculado empleando la ec. (27). Esta figura muestra un ejemplo de interferencia entre portadoras del mismo tamaño. Además, esta figura indica la variación del factor de reducción de interferencia para el caso de una sola portadora de interferencia, mientras que en arreglos de frecuencias reales de transponders deben de considerarse la interferencia entre dos portadoras adyacentes en el transponder interferido como se ve de la figura (7).

De la figura (8) se observa que, en el caso donde la diferencia de las frecuencias centrales F_{ode} de las portadoras interferidas e interferidas-con es igual a la mitad de su ancho de

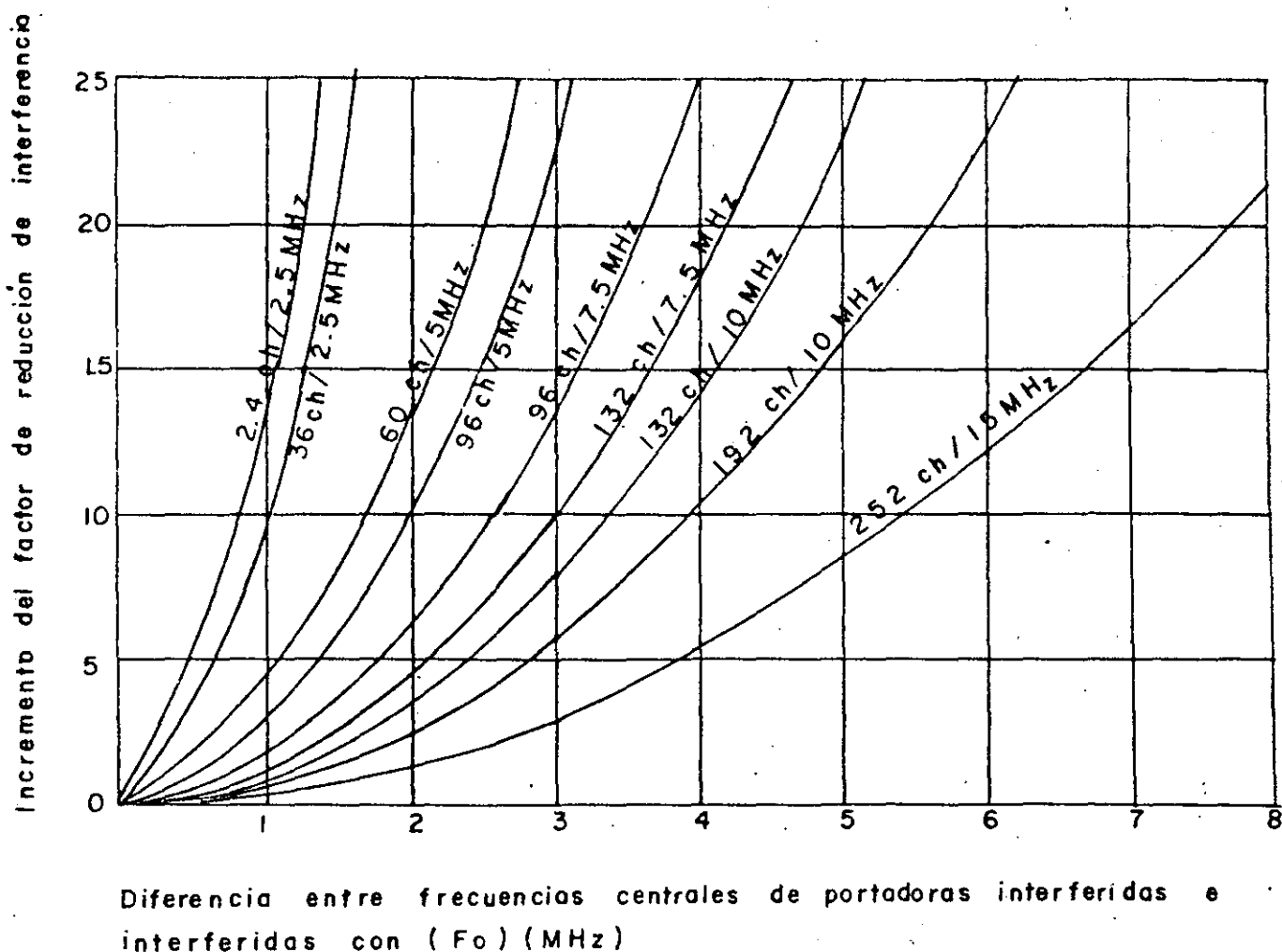


Fig.(8) Variación del factor de reducción debido a la interrelación de frecuencia (para el caso donde la interferencia con portadoras tienen igual tamaño.)

banda de la frecuencia asignada dentro del satélite, el ruido de interferencia es reducido por 16 a 23 db. Se deduce además que cuando las dos portadoras adyacentes se acomodan en un transponder de interés y son consideradas, el efecto de distribución de frecuencias alcanza de 13 a 20 db como un máximo.³

La tabla IV muestra los parámetros empleados para el diseño de enlaces por satélite para el sistema INTELSAT IV-A. Las tablas V y VI muestran ejemplos de valores de potencia de enlace y de ruido para el transponder de haz Hemisférico en un modo de transmisión de portadora múltiple respectivamente.

TABLA IV

Parámetros de diseño para un enlace telefónico multicanal mediante satélite. (INTELSAT IV-A)

LOS OBJETIVOS DE CALIDAD SON

- Ruido del canal - $10\ 000 P_{\omega op}$ (-50 dbmop)
- Ruido de enlace más ruido de interferencia según normas debido a otros sistemas por satélite deben ser de $7\ 500 P_{\omega op}$.
- Mejoramiento de la relación señal a ruido por énfasis 4 db a la frecuencia superior de la banda base.
- Factor de ponderación 2.5 db
- Factor pico 3.16 (= 10 db)
- Ancho de banda ocupada $2(3.16\sigma + f_m)$, Hz
- Guarda-bandas entre portadoras adyacentes mas del 10% del ancho de banda asignado.
- Nivel de carga de circuitos telefónicos multicanales
 - $1 + 4 \log n$ (db) ($12 < n \leq 240$)
 - $15 + 10 \log n$ (db) ($n \geq 240$)

³Un caso en el cual la frecuencia central de la portadora interfiere con, cae a la mitad de dos portadoras interferentes de igual tamaño.

64

645

- Pérdida en el espacio libre
 $L_p = 32.4 + 20 \log f(\text{MHz}) + 20 \log(41756) = 200.6 \text{ db (6GHz)}$
 $L_p = 32.4 + 72 + 92.4 = 196.85 \text{ db (4GHz)}$
- Figura de mérito de la estación terrena ($\frac{G}{T}$) norma
 A 40.7 dbK (en la dirección del satélite a 4 GHz)
- Figura de mérito del satélite ($\frac{G}{T}$) en el lado del haz
 -17.6 dbK (haz global); -11.6dbK (haz hemisférico).
- Densidad de flujo de potencia para saturar el transpon
 der del satélite (en el lado del haz)
 - 67.5 $\text{db}\omega/\text{m}^2$ (haz global entrada de portadora múltiple)
 - 67.5 $\text{db}\omega/\text{m}^2$ (haz hemisférico/puntual entrada portadora múltiple)
 - 75.0 db/m^2 (haz hemisférico/puntual, entrada de una sola portadora)
- EIRP de saturación del satélite (al lado del haz)
 - 22 $\text{db}\omega$ (haz global)
 - 26 $\text{db}\omega$ (haz hemisférico)
 - 29 $\text{db}\omega$ (haz puntual)
- Punto de operación (banck-off) de
 Entrada del transponder del satélite
 - 10 db (haz global)
 - 11 db (haz hemisférico)
 - 12 db (haz puntual)
- Punto de operación de
 Salida del transponder del satélite
 - 4.2 db (haz global)
 - 6.0 db (haz hemisférico)
 - 7.0 db (haz puntual)
- Aislamiento entre antenas este y oeste
 $\frac{C}{I} = 27 \text{ db}$ (para ambos UP-LINK y DOWN LINK)

TABLA V

Ejemplo de la potencia requerida en el enlace en el modo de transmisión multiportadora de un transponder de haz hemisférico en el satélite INTELSAT-IV A

- Ancho de banda empleable del transponder (36 MHz x 0.9)	75.1 db Hz
- Densidad de flujo de potencia de entrada de portadora múltiple para saturar el transponder ($\text{db}\omega/\text{m}^2$)	- 67.5
- Ganancia de la antena de Area efectiva de 1m^2 a 6GHz (db)	37
- Punto de operación (Back-off) de entrada del transponder en db	11
- $\frac{G}{T}$ del satélite en dbK	-11.6
- $\frac{C}{N_0}$ que relaciona el ruido térmico del UP-LINK $\text{db}\times\text{Hz}$	101.5
- EIRP de saturación del satélite (al lado del haz) ($\text{db}\omega$)	26
- Punto de operación (Back-off) de salida del transponder (db)	6
- Pérdida en el espacio libre en el enlace DOWN-LINK en 4 GHz	196.7
- Factor de compensación de la EIRP del satélite desde el lado del haz en (db)	0.6 ¹
- $\frac{G}{T}$ de la estación terrena en dbK	40.7
- $\frac{C}{N_0}$ que relaciona al ruido térmico del DOWN-LINK $\text{db}\times\text{Hz}$	93.2
- $\frac{C}{N_0}$ que relaciona el ruido de intermodulación dentro del transponder de un satélite $\text{db}\times\text{Hz}$	96.9 ¹

~~656~~

- $\frac{C}{N_0}$ que relaciona a la interferencia intra sistema para enlaces UP y DOWN LINK ² dbxHz	98.1 ¹
- $\frac{C}{N_0}$ Total ³ db.Hz	90.4
- $\frac{C}{N}$ Total ³ db	15.3

¹Un valor típico

²Incluye mejoramiento por distribución intercalada de frecuencia.

³Valor compuesto para portadoras múltiples.

T A B L A V I

Ejemplo de la cantidad de ruido en el modo de transmisión de portadora múltiple del transponder del haz hemisférico del sistema Intelsat IV-A (caso donde el ruido de enlace es igual a 6 500 p_{wop})

- Ruido térmico del UP-LINK (p _{wop})	507
- Ruido térmico del DOWN-LINK (p _{wop})	3424
- Ruido de intermodulación dentro del satélite (p _{wop})	1461
- Ruido de interferencia intrasistema en enlaces UP-LINK y DOWN-LINK (p _{wop})	1108

UN 657

648

4.- DISEÑO DE ENLACES DE TELEVISION

4.1 ENLACES DE VIDEO PARA TELEVISION

El diseño de enlaces de video para televisión vía satélite, se desarrolla con respecto al circuito hipotético de referencia que se describe en la sección (1.1).

La calidad de los enlaces de televisión, se expresa en términos de varios factores. Uno de los factores fundamentales es el ruido aleatorio continuo el cual corresponde al ruido del canal sobre un circuito telefónico multicanal. La razón de la señal de video al ruido aleatorio continuo para la transmisión de F.M. está dada por:

$$\left[\frac{S_p - p}{N_w} \right] = \left[\frac{C}{N_o} \right] + 20 \log \left(\frac{\gamma_{\ell} - \Delta F_{p-p}}{f_m} \right) - 10 \log \frac{f_m}{3} + [P] + [Q] \quad \text{-----} \quad 29$$

Donde:

$\left[\frac{S_p - p}{N_w} \right]$ - Razón de la amplitud nominal de la señal de luminancia a la amplitud r.m.s. del ruido medido después de limitarse en banda y ponderarse con una red específica (db).

γ_{ℓ} - Razón de la amplitud pico a pico de una señal de video compuesta monocromática a la amplitud nominal de la señal de luminancia (0.7 para 525/60, 0.714 para 625/50).

ΔF_{p-p} - Desviación de frecuencia pico a 15 KHz (H_z)

f_m - Frecuencia máxima de banda base (H_z).

$[P]$ - Mejoramiento por énfasis (db)

$[Q]$ - Factor de ponderación (db)

Como se estableció en la sección (1.3) el CCIR especifica una

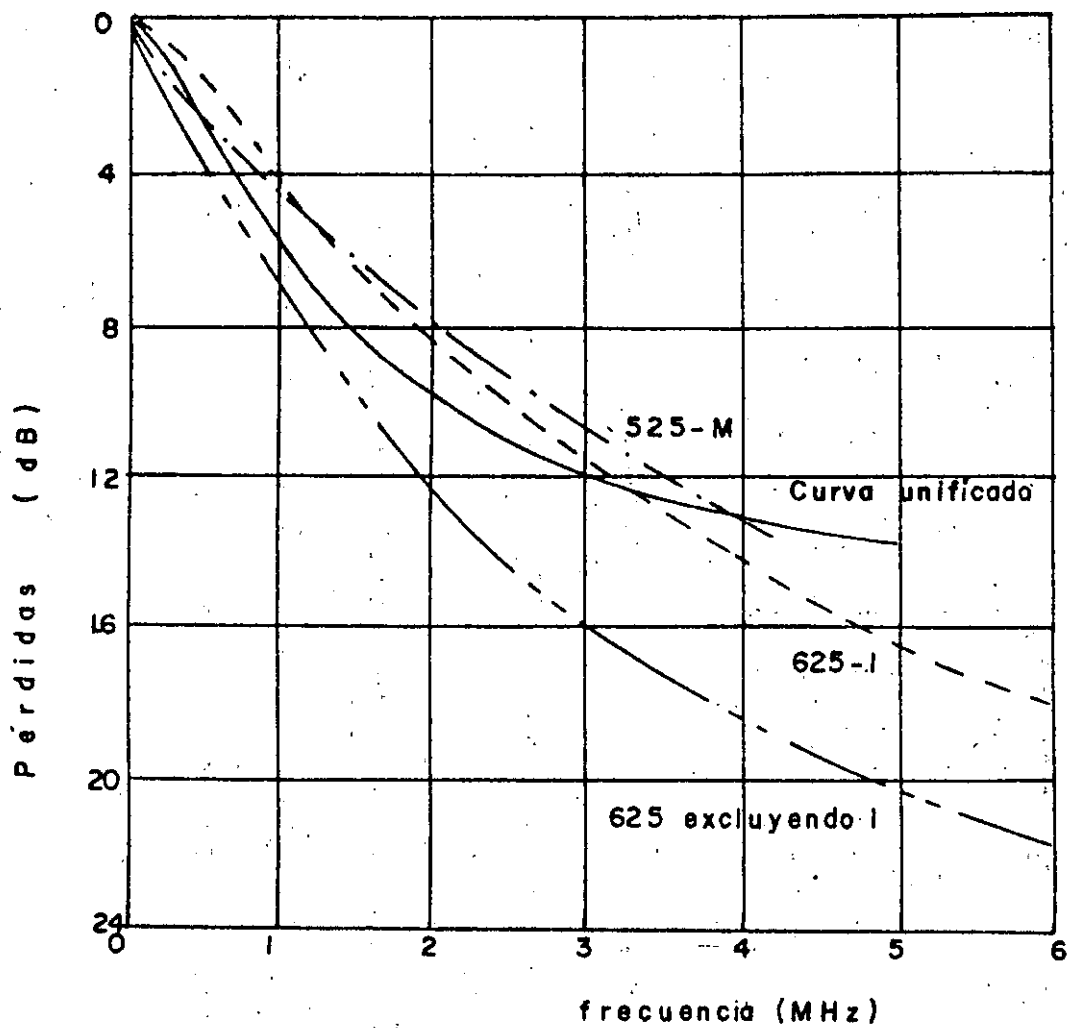


Fig. 9 Características de frecuencia de redes Ponderadas para la medición de ruido aleatorio continuo.

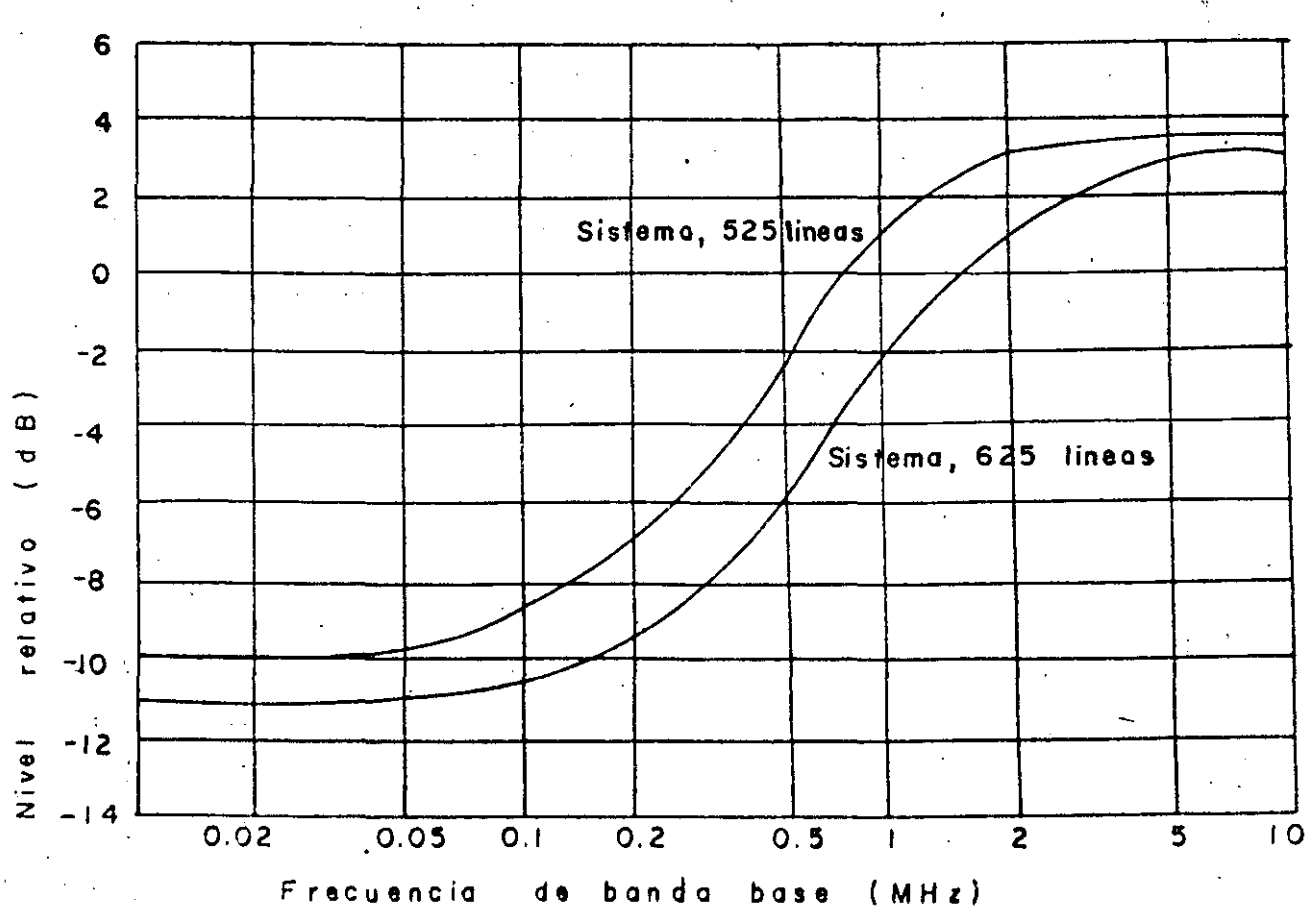


Fig. 10 Características de Preénfasis para sistemas 525/60 y 625/50 (Rec. del CCIR 405-1).

una idéntica razón, señal a ruido que relaciona al ruido aleatorio continuo, para sistemas de 525/60 y 625/50. Nominalmente la $\frac{S}{N}$ debe ser igual a o mejor que 53 db para el 99% del tiempo y 45 db para 99.9% del tiempo (recomendación 567) esta recomendación fue --- adoptada en la asamblea plenaria del CCIR en 1978, y las características de frecuencia anteriores de redes de ponderación, las cuales han sido definidas separadamente para diferentes normas de televisión, fueran reemplazadas por un solo conjunto de características que dan objetivos unificados de $\frac{S}{N}$.

La figura 9 muestra la curva unificada así como las características de frecuencia anteriores de redes ponderadas. La fig. 10 presenta las características de énfasis para normas de 525 y 625 líneas.

En la tabla VIII se presentan los factores de conversión¹ para el ruido triangular en el caso de la curva unificada.

Intelsat ha definido dos tipos de modos de transmisión de TV, un modo con un transponder completo empleando un ancho de banda de 30 MHz y un modo de medio transponder empleando un ancho de banda de 17.5 MHz. En la actualidad el último modo es el más empleado.

En la tabla IX se indica los parámetros de transmisión para los dos tipos anteriores. La tabla X representa los valores $\frac{S_{p-p}}{N_w}$ los cuales fueron calculados en base a los parámetros dados en la tabla (IX) aplicando ambas curvas la anterior y la unificada.

4.2 ENLACE DE AUDIO PARA TELEVISION

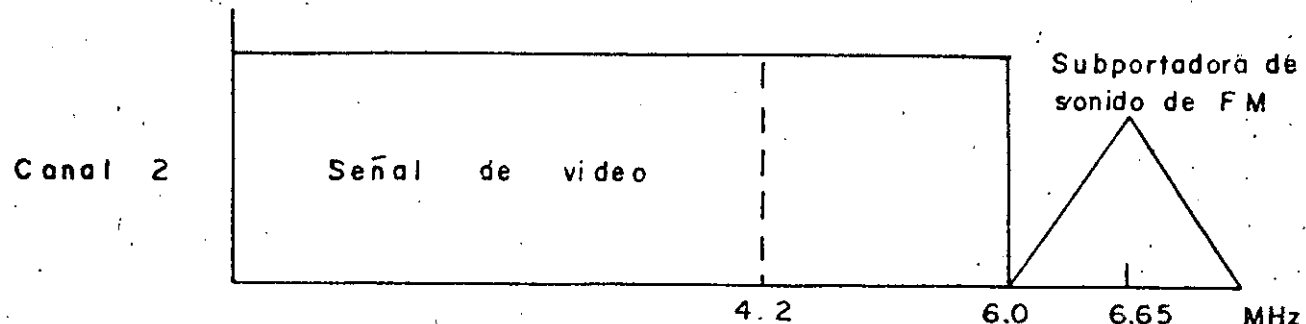
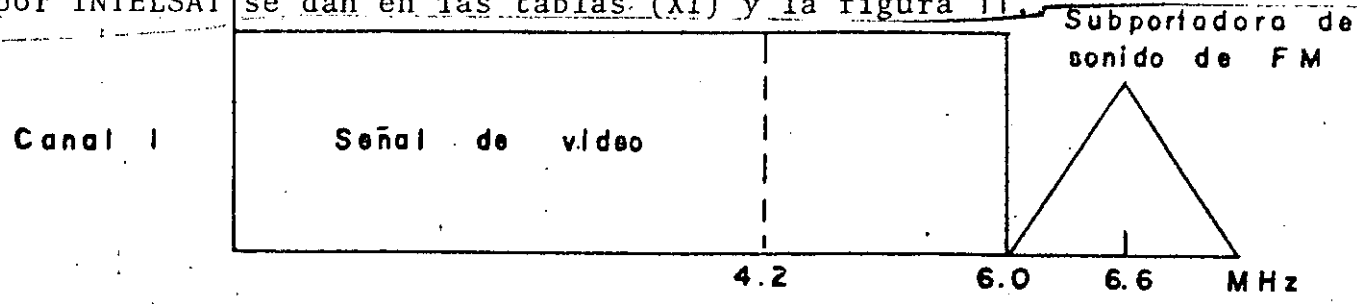
En el sistema INTELSAT, las señales de audio y video para televisión han sido hasta ahora, transmitidas separadamente. En es-

1.- Mejoramiento por énfasis más factor de ponderación (P + Q).

te caso, la señal de audio de televisión (Recomendada del tipo A - por el CCITT) está modulada en frecuencia y transmitida por una portadora equivalente a 24 canales telefónicos (ancho de banda asignada de 2.5 MHz). En el caso de la transmisión con el transponder completo (ancho de banda asignado 30 MHz), la portadora de audio puede acomodarse dentro de un transponder que tenga 36 MHz de ancho de banda, mientras que en el caso de una transmisión de medio transponder (ancho de banda asignado 17.5 MHz) dos portadoras de video son acomodados en un solo transponder y así los portadores de audio tienen que acomodarse en otro transponder.

Con el reciente crecimiento en la demanda para los servicios de transmisión de televisión, el esquema mencionado anteriormente está muy lejos de ser eficiente, desde el punto de vista de la utilización de las bandas de frecuencia. Esto obligó a INTELSAT a introducir el así llamado sistema de Subportadora de F.M. En este sistema, una subportadora está modulada en frecuencia por la señal del programa de sonido. La señal modulada está combinada con una señal de video que viene a estar otra vez modulada en frecuencia.

A través de este proceso, la señal de sonido puede ser transmitida en una portadora de video de televisión. Los parámetros principales y arreglos de frecuencia de este sistema especificado por INTELSAT se dan en las tablas (XI) y la figura 11.

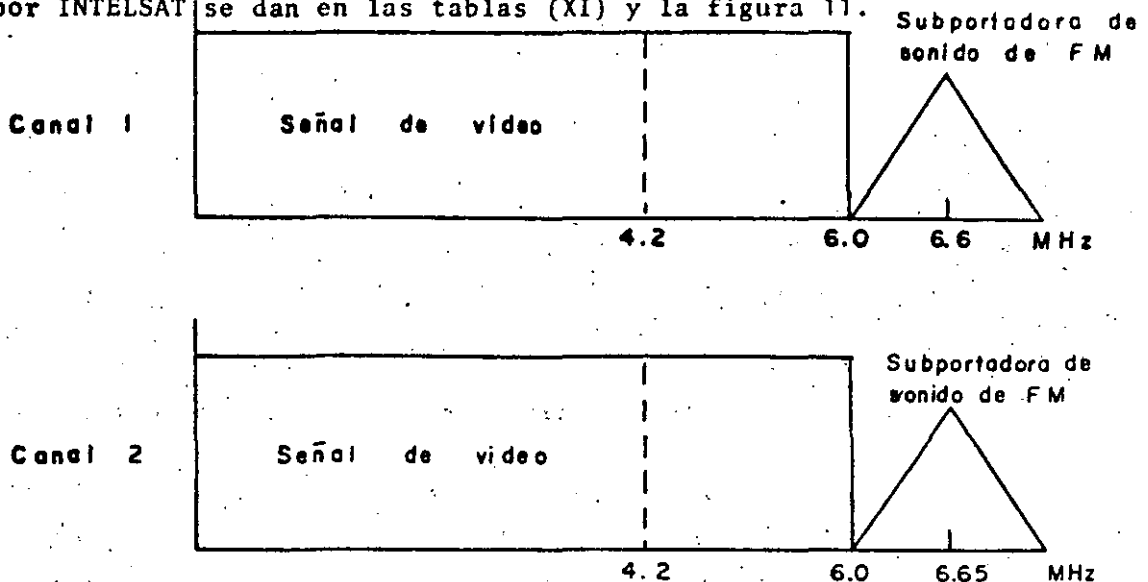


00 659

te caso, la señal de audio de televisión (Recomendada del tipo A por el CCITT) está modulada en frecuencia y transmitida por una portadora equivalente a 24 canales telefónicos (ancho de banda --- asignada de 2.5 MHz). En el caso de la transmisión con el transponder completo (ancho de banda asignado 30 MHz), la portadora de audio puede acomodarse dentro de un transponder que tenga 36 MHz de ancho de banda, mientras que en el caso de una transmisión de medio transponder (ancho de banda asignado 17.5 MHz) dos portadoras de video son acomodados en un solo transponder y así los portadores de audio tienen que acomodarse en otro transponder.

Con el reciente crecimiento en la demanda para los servicios de transmisión de televisión, el esquema mencionado anteriormente está muy lejos de ser eficiente, desde el punto de vista de la utilización de las bandas de frecuencia. Esto obligó a INTELSAT a introducir el así llamado sistema de Subportadora de F.M. En este sistema, una subportadora está modulada en frecuencia por la señal del programa de sonido. La señal modulada está combinada con una señal de video que viene a estar otra vez modulada en frecuencia.

A través de este proceso, la señal de sonido puede ser transmitida en una portadora de video de televisión. Los parámetros principales y arreglos de frecuencia de este sistema especificado por INTELSAT se dan en las tablas (XI) y la figura 11.



Fig(11) Arreglo de frecuencias en el sistema de subportadora de audio (INTELSAT)

TABLA VII

LIMITACIONES EN FRECUENCIAS COMPARTIDAS SUPERIORES A 1 MHz

ESTACION	ESPECIFICACION	GAMA DE FRECUENCIAS	VALOR MAXIMO PERMITIDO	ANGULO DE ANTENA	NOTAS
ESTACION TERRENA	ANTENA DIRECCIONAL Y EIRP	Superior a 1GHz 1-10GHz 10-15GHz Superior a 15GHz	+ 55 dbw + 35 dbw(1) + 45 dbw Sin Límite	$\Delta \geq 2^\circ$ $\Delta \geq 1.5^\circ$	Δ - Angulo entre la dirección del satélite geostacionario y la dirección del haz de la antena. (1)- Aplicable a nuevas estaciones, excepto el caso donde el valor de Δ es pequeño.
	POTENCIA DE ENTRADA DE ANTENA	1-10 GHz Superior a 10GHz	+ 13 dbw + 10 dbw		Valor máximo
ESTACION TERRENA	EIRP CERCA DEL HORIZONTE	Superior a 15GHz	+ 64dbw/1MHz (+64+3 θ)dbw/1MHz	$\theta \leq 0^\circ$ $0^\circ \leq \theta \leq 5^\circ$	θ Angulo de elevación, en el caso de que otra administración esté fuera del área de coordinación, pueden sumarse hasta 10 db (sat. fijo). Pueden sumarse hasta 15db para investigación espacial profunda. No se limita si $\theta > 5^\circ$.
	MAXIMO ANGULO DE ELEVACION DE LA ANTENA			3°	Excepción: 5° (Investigación espacial) 10° (Investigación espacial profunda)
	MAXIMA RADIACION LATERAL PERMITIDA.	6 GHz	(35-25logf)dbw/4KHz -7dbw/4KHz	$2.5^\circ \leq \phi \leq 48^\circ$ $48^\circ \leq \phi \leq 180^\circ$	ϕ Angulo de la dirección del haz de la antena (Rec. CCIR 524) aplicable a la transmisión de satélite fijo para proteger en tres grados de ancho la órbita geostacionaria.
		1.67 - 1.7 GHz	-133dbw/m ² /1.5MHz		Satélites de exploración de la Tierra (satélites meteorológicos)
			$\frac{Adbw/m^2/4KHz}{(A+1) \frac{0.5}{2}}$ dbw/m ² /4KHz	$0^\circ \leq \theta \leq 5^\circ$ $5^\circ \leq \theta \leq 25^\circ$	θ Angulo de elevación
ESTACION ESPACIAL	DENSIDAD DE FLUJO DE POTENCIA MAXIMA PERMITIDA EN LA SUPERFICIE DE LA TIERRA		Cdbw/m ² /4Ghz	$25^\circ \leq \theta \leq 90^\circ$	
		1.525 - 2.5 GHz	A -154 B 1 C -144		Satélites meteorológicos, Investigación espacial, operación espacial.
		2.5 - 2.69 GHz	-152 3/2 -137		Satélites fijos, Satélites de radiodifusión.
		3.4 - 7.75 GHz	-152 1 -142		Satélites fijos, satélites móviles, Satélites Meteorológicos, Investigación espacial.
		8.025 - 11.7 GHz	-150 1 -140		Satélites fijos, espaciales, de exploración de la tierra.
		12.2 - 12.75 GHz	-148 1 -138		Satélites fijos
		17.7 - 19.7 GHz	-115 1 -101		Satélites fijos, de exploración la tierra, Meteorológicos.
		31.0 - 40.5 GHz	-115 1 -105		Satélites fijos, móviles, operación espacial
MANTENIMIENTO DE LA ESTACION			$\pm 0.1^\circ$		Satélites fijos, radiodifusión
			$\pm 0.5^\circ$		Experimentales, otros.
			$\pm 1^\circ$		Estaciones espaciales que se publicaron antes del 1°/VI/82 y debieron iniciar el servicio antes del 1°/I/87. Blanco 0.5°
EXACTITUD DE ENFOQUE		10% del ancho de Banda a media potencia ó 0.3°		Menor que el valor más grande	
SUSPENSION DE RADIACION			El equipo debe estar provisto. Si se solicita el comando debe de darse remotamente.		

TABLA VII

LIMITACIONES EN FRECUENCIAS COMPARTIDAS SUPERIORES A 1 MHz

ESTACION	ESPECIFICACION	GAMA DE FRECUENCIAS	VALOR MAXIMO PERMITIDO	ANGULO DE ANTENA	NOTAS
ESTACION RRRENA	ANTENA DIRECCIONAL Y EIRP	Superior a 1GHz 1-10GHz 10-15GHz Superior a 15GHz	+ 55 dbw + 35 dbw(1) + 45 dbw Sin Límite	$\Delta > 2^\circ$ $\Delta > 1.5^\circ$	Δ - Angulo entre la dirección del satélite geostacionario y la dirección del haz de la antena. (1)- Aplicable a nuevas estaciones, excepto el caso donde el valor de Δ es pequeño.
	POTENCIA DE ENTRADA DE ANTENA	1-10 GHz Superior a 10GHz	+ 13 dbw + 10 dbw		Valor máximo
ESTACION RRRENA	EIRP CERCA DEL HORIZONTE	Superior a 15GHz	+ 64dbw/1MHz (+64+3 θ)dbw/1MHz	$\theta \leq 0^\circ$ $0^\circ \leq \theta \leq 5^\circ$	θ Angulo de elevación, en el caso de que otra administración esté fuera del área de coordinación, pueden sumarse hasta 10 db (sat. fijo). Pueden sumarse hasta 15db para investigación espacial profunda. No se limita si $\theta > 5^\circ$.
	MAXIMO ANGULO DE ELEVACION DE LA ANTENA			3°	Excepción: 5° (Investigación espacial) 10° (Investigación espacial profunda)
	MAXIMA RADIACION LATERAL PERMITIDA.	6 GHz	(35-25log ϕ)dbw/4KHz -7dbw/4KHz	$2.5^\circ \leq \phi < 48^\circ$ $48^\circ \leq \phi < 180^\circ$	ϕ Angulo de la dirección del haz de la antena (Rec. CCIR 524) aplicable a la transmisión de satélite fijo para proteger en tres grados de ancho la órbita geostacionaria.
		1.67 - 1.7 GHz	-133dbw/m ² /1.5MHz		Satélites de exploración de la Tierra (satélites meteorológicos)
			$\frac{A+B}{2} \text{ dbw/m}^2/4\text{GHz}$ $\frac{A+B}{2} \text{ dbw/m}^2/4\text{KHz}$	$0^\circ < \theta \leq 5^\circ$ $5^\circ < \theta < 25^\circ$	θ Angulo de elevación

655-A

667

		Cdbw/m ² /4Ghz			25° < θ < 90°	
		A	B	C		
DENSIDAD DE FLUJO DE POTENCIA MAXIMA PERMITIDA EN LA SUPERFICIE DE LA TIERRA	1.525 - 2.5 GHz	-154	1	-144		Satélites meteorológicos, Investigación espacial, operación espacial.
	2.5 - 2.69 GHz	-152	3/2	-137		Satélites fijos, Satélites de radiodifusión.
	3.4 - 7.75 GHz	-152	1	-142		Satélites fijos, satélites móviles Satélites Meteorológicos, Investigación espacial.
	8.025 - 11.7 GHz	-150	1	-140		Satélites fijos, espaciales, de exploración de la tierra.
	12.2 - 12.75 GHz	-148	1	-138		Satélites fijos
	17.7 - 19.7 GHz	-115	1	-101		Satélites fijos, de exploración la tierra, Meteorológicos.
	31.0 - 40.5 GHz	-115	1	-105		Satélites fijos, móviles, operación espacial
	MANTENIMIENTO DE LA ESTACION		± 0.1°			
		± 0.5°				Experimentales, otros.
		± 1°				Estaciones espaciales que se publicaron antes del 1°/VI/82 y debieron iniciar el servicio antes del 1°/I/87. Blanco 0.5°
EXACTITUD DE ENFOQUE		10% del ancho de Banda a media potencia ó 0.3°				Menor que el valor más grande
SUSPENSION DE RADIACION		El equipo debe estar provisto. Si se solicita el comando debe de darse remotamente.				

5.- ENERGIA DISPERSA DE PORTADORAS DE F.M.

5.1 LIMITACION DE LA DENSIDAD DE FLUJO DE POTENCIA.

Dado que la banda de frecuencia localizada para el servicio de satélite fijo se comparte en muchos casos con los sistemas de radio superficiales, las portadoras transmitidas desde las estaciones terrenas o desde satélites pueden interferir con sistemas de radio de superficie. La interferencia mútua entre sistemas de comunicación por satélite para los servicios de satélite fijos -- también puede ocurrir si emplean la misma banda de frecuencia.

Con el fin de mantener la cantidad de ruido de interferencia dentro de un nivel permisible, la densidad de energía de las ondas de radio transmitidas desde las estaciones terrenas deben estar limitadas a un cierto nivel.

En las regulaciones de radio, la máxima densidad de flujo de potencia permitida en la superficie de la tierra debido a ondas de radio que provienen de satélites se especifica como se muestra en la tabla VII. Además, la recomendación 524 del CCIR, recomienda que a cualquier ángulo de 2.5° ó más a partir del eje del lóbulo principal de una antena en una estación terrena, EIRP en 4 KH_z en cualquier dirección dentro de los grados de la órbita del satélite geostacionario no debe exceder los siguientes valores.

$$P_m = 35 - 25 \log \phi \frac{\text{dbw}}{4 \text{ KH}_z} ; (2.5^\circ \leq \phi \leq 48^\circ) \text{ ---- (30)}$$

Donde:

- ϕ - Angulo a partir del eje en grados
- P_m - Máxima EIRP permitida a 4 KH_z en cualquier dirección dentro de tres grados de la órbita del satélite geostacionario.

Con el fin de obtener, muchos canales de comunicaciones por satélite con una calidad aceptable bajo las condiciones mencionadas anteriormente, se requiere distribuir la energía de las porta-

doras transmitidas desde las estaciones terrenas. Para este propósito se han empleado técnicas llamadas de dispersión de energía.

La energía dispersa es también empleada para reducir la densidad de ruido de intermodulación en transponders de satélites o amplificadores de alta potencia de estaciones terrenas.

La recomendación 466 del CCIR recomienda que deben emplearse técnicos de dispersión de energía en las estaciones terrenas para los servicios de satélites fijos.

6.- SISTEMAS DE COMUNICACION DE SATELITES DIGITALES

Como se mencionó anteriormente FDM-FM-FDMA es la técnica más popular en la actualidad en los sistemas de comunicación de satélites comerciales. Esto se debe a que FDM-FM-FDMA es una técnica muy experimentada y comparativamente más fácil de proporcionar enlaces de comunicación con alta calidad y bajo costo. Recientemente se han enfatizado sus desventajas tales como la ineficiencia en la utilización de la potencia del satélite y la inflexibilidad para llevar a cabo arreglos en el circuito. Por lo tanto, se desea la utilización de sistemas de comunicación más eficientes y más versátiles, que respondan a las variaciones de tráfico y que cumplan con las demandas requeridas de las estaciones terrenas de baja capacidad. Los sistemas de comunicación de satélites digitales prometen cumplir con este punto de vista, además que son capaces de transmitir datos a alta velocidad, formando en lo futuro

redes digitales integradas.

Pueden realizarse varios tipos de sistemas de comunicación de satélites digitales, al llevar a cabo una combinación de codificación, multicanalización y modulación. Por ejemplo hay un sistema FDMA (Acceso múltiple por división de frecuencia) llamado SCPC (solo ^{un} canal por portadora), en el cual un solo canal a nivel de voz es transmitido por una portadora. Se está planeando que los sistemas TDMA (acceso múltiple por división de tiempo) combinados con multicanalización por división de tiempo (TDM) PCM se utilicen en varios sistemas de comunicación por satélite.

La fig (12) muestra un ejemplo de la capacidad calculada de canales a nivel de voz por transponder de satélite en función del número de estaciones terrenas de acceso para los casos de FDM - FM - FDMA, PCM - TDM - PSK - TDMA y SCPC.

Se puede observar de esta figura que cuando se incrementa el número de estaciones terrenas, las ventajas de los sistemas digitales es más notable.

Asociados con los sistemas de comunicación de satélite digital, hay esquemas que proporcionan un incremento adicional de eficiencia. Uno de estos esquemas es una técnica de interpolación de conversación del tipo digital llamada DSI (interpolación de conversación digital). Cuando se aplica al TDMA se puede esperar que se duplique la capacidad de canales de voz. Otros esquemas que sirven para incrementar la utilización del ancho de banda, hacen uso de la naturaleza de las señales de la fuente.

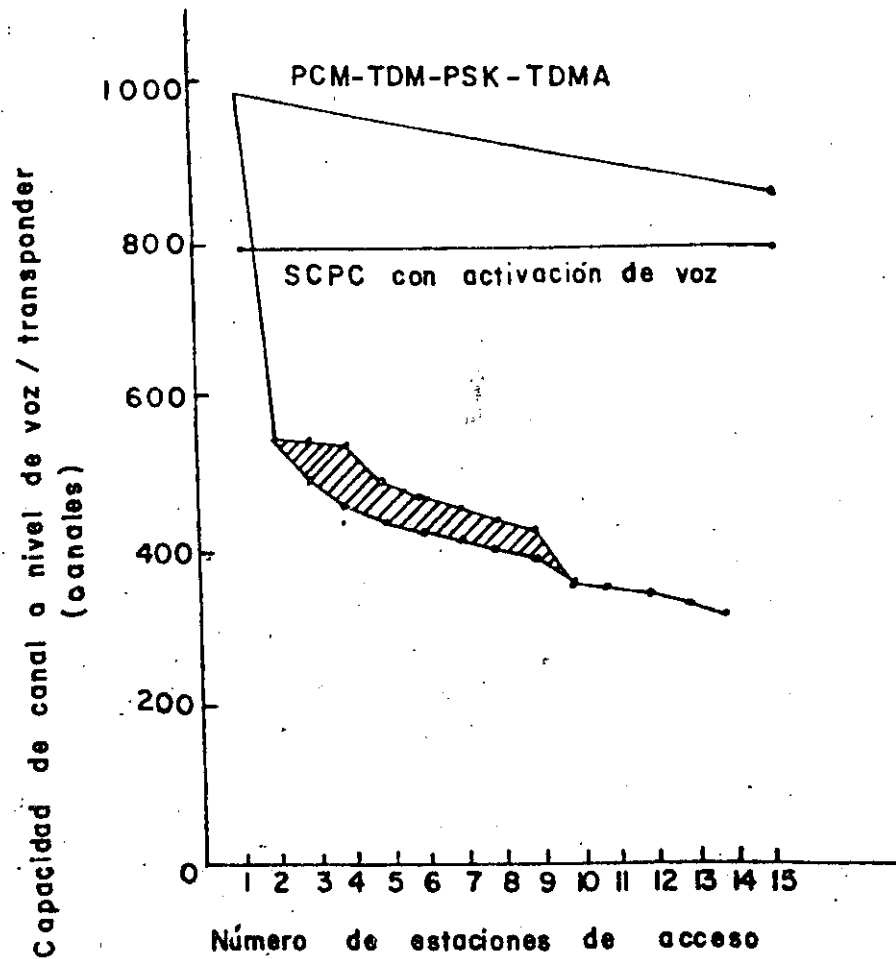


Fig. (12) CAPACIDAD DE CANAL A NIVEL DE VOZ DE SISTEMAS DE ACCESO MULTIPLE

Los haces puntuales múltiples son muy efectivos para elevar la capacidad del canal del satélite.

El TDMA aplicado a un satélite con haz puntual múltiple, el cual lleva un conjunto de conmutadores a bordo para conmutar los haces en una base de división por tiempo se le llama SS (Satellite - Switched) - TDMA. Este sistema puede proporcionar una mayor eficiencia que el sistema con una conexión fija entre haces.

6.1 MODULACION DIGITAL.

Una de las funciones fundamentales en los sistemas de comunicación de satélites digitales es la modulación. Las modulaciones digitales típicas son la ASK (modulación por desviación de amplitud), FSK (modulación por desviación de frecuencia), PSK (modulación por desviación de fase) y la modulación compuesta APK (modulación por desviación amplitud-fase).

En la comunicación por satélite digital generalmente se desea emplear una modulación que no sea afectada fácilmente por el ruido y por la no linealidad de los amplificadores que lleva el satélite.

7. CALCULO DEL ENLACE DE CANALES SCPC

Si se considera que se transmiten 800 canales SCPC a través de un transponder de 36 MHz de ancho de banda del satélite INTELSAT IV, el cálculo del enlace puede realizarse de la siguiente manera:

Primero la razón de la potencia de la portadora total a la temperatura de ruido $(C/T)_T$ está dada por la expresión siguiente:

Por otro lado, se supone que el valor total del margen del enlace y el margen de implementación es de 2.8 db basándose en las especificaciones del INTELSAT, las C/T requerida para obtener el nivel de umbral de error de bits de 10^{-4} viene a ser -169.3 dbwK para 64 Kbits/s con detección coherente QPSK. Por lo tanto el margen de umbral, o sea la diferencia entre este valor y $(C/T)_T$, es de 2 db.

8. CALCULO DE ENLACE PARA SISTEMAS TDMA

En esta sección se describe el cálculo de un enlace para sistemas TDMA en el cual se han acomodado señales telefónicas en PCM.

La calidad de señales telefónicas PCM se especifica generalmente por error del bit.

El CCIR recomienda los valores mostrados a continuación como el error de bit tolerable para el servicio de satélite fijo empleando PCM para telefonía.

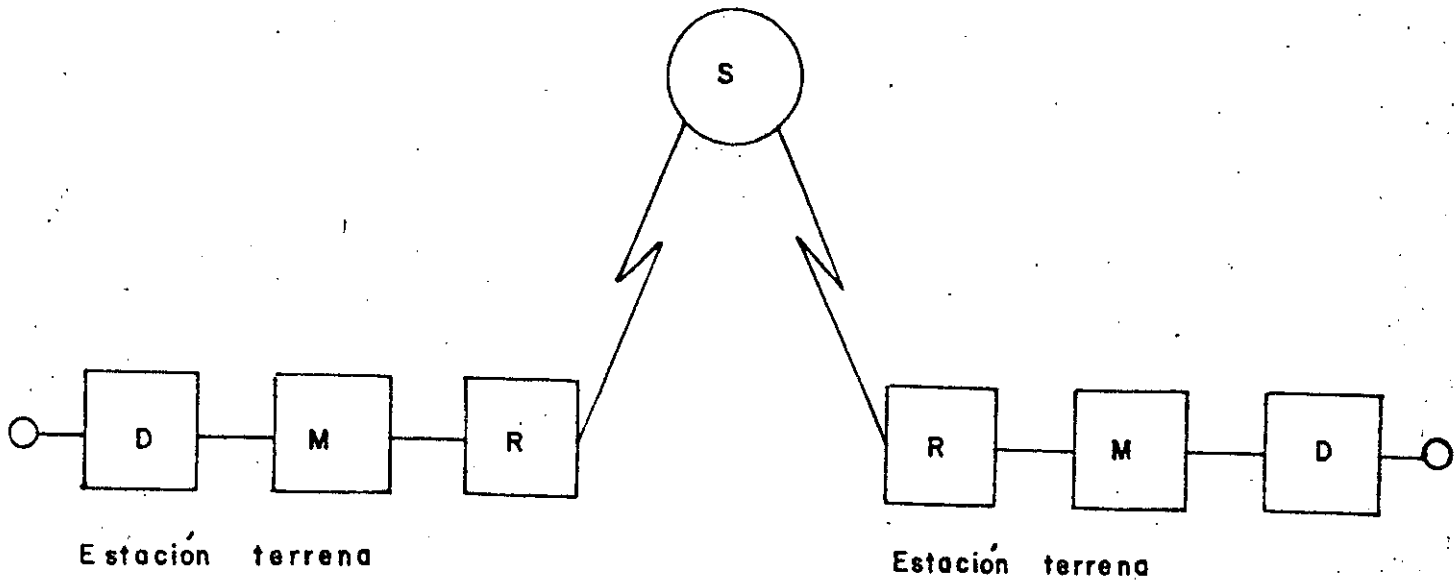
El CCIR recomienda el circuito hipotético de referencia que se muestra en la fig.(13)

El valor de error del bit a la salida del circuito hipotético de referencia ¹ no debe ser superior a los valores provisionales siguientes.

- (1) Una parte en 10^6 , valor promedio en 10 min. para más del 20% de cualquier mes.
- (2) Una parte en 10^4 , valor promedio en 1 min. para más del 0.3% de cualquier mes.
- (3) Una parte en 10^3 , valor promedio en 1 seg. para más del 0.01% de cualquier mes.

1 Recomendación del CCIR 521

2 Recomendación del CCIR 522



S - Estaciones espaciales en el servicio de satélites ó estación espacial en el servicio de satélites fijos interconectados -- por enlace de satélite.

D - Equipo de interferencia digital directo (DDIE)

M - Equipo MODEM (incluyendo el equipo TDMA si es requerido)

R - Equipo de FI/RF

Fig (13) CIRCUITO HIPOTETICO DE REFERENCIA PARA SISTEMAS DE TRANSMISION DIGITAL EN EL SERVICIO DE SATELITES FIJOS

Basándose en estos objetivos de calidad y si se considera que un sistema TDMA modulado en 4 fases PCK ocupa el transponder de un satélite. En el enlace TDMA, la razón de potencia de portadora a temperatura de ruido $(C/T)_T$ que se obtiene en el receptor está dada por¹

$$(C/T)_T^{-1} = (C/T)_u^{-1} + (C/T)_d^{-1} + (C/T)_{su}^{-1} + (C/T)_{ld}^{-1} \quad (35)$$

donde.

$(C/T)_u$ - Es la C/T del ascenso

$(C/T)_d$ - Es la C/T del descenso

$(C/T)_{lu}$, $(C/T)_{ld}$ - Son las (C/T) equivalentes debido al ruido de interferencia en el ascenso y descenso respectivamente

$(C/T)_u$ y $(C/T)_d$ pueden calcularse sustituyendo $n=1$ en las ecuaciones (32) y (33). $(C/T)_{lu}$ y $(C/T)_{ld}$ también pueden calcularse empleando la ecuación (34) si se conoce la razón de potencia de portadora a la potencia de interferencia (C/T) .

Las fuentes de interferencia en el up-link incluyen la emisión fuera de banda del transmisor de la estación terrena, los productos de intermodulación debidos a la amplificación común de portadoras múltiples en los amplificadores de alta potencia de la estación terrena, y la interferencia co-canal entre diferentes haces y entre polarizaciones ortogonales. En el down-link existe la interferencia co-canal entre haces y entre polarizaciones ortogonales, interferencia de enlaces terrestres

y otros sistemas de comunicación por satélite e interferencia de canales adyacentes, no obstante la influencia de estas fuentes interferentes son diferentes, dependiendo del sistema de comunicación por satélite individual, las interferencia co-canal entre haces y polarizaciones ortogonales son dominantes en el caso del sistema de comunicaciones del INTELSAT IV.

Además de la interferencia, el problema más crítico en la transmisión de señales TDMA moduladas en QPSK es la distorsión de la forma de onda debido a la no linealidad del amplificador de potencia del satélite. En general cuando el punto de operación del amplificador de potencia del satélite se eleva, la influencia del ruido disminuye; pero esto da como resultado una mayor distorsión en la forma de onda.

La fig.(14) muestra un ejemplo del cálculo del valor de error del bit de la señal QPSK en función del punto de operación de entrada del amplificador de potencia del satélite en el cual se supone que se emplea TOP.

1 No obstante que la contribución de interferencia dentro del valor de error del bit es diferente a la del ruido térmico, el error calculado es lo bastante pequeño por lo que se considera que en el cálculo del enlace sus contribuciones son idénticas. De acuerdo a esto el ruido total se considera como la suma de las potencias del ruido térmico y de interferencia.

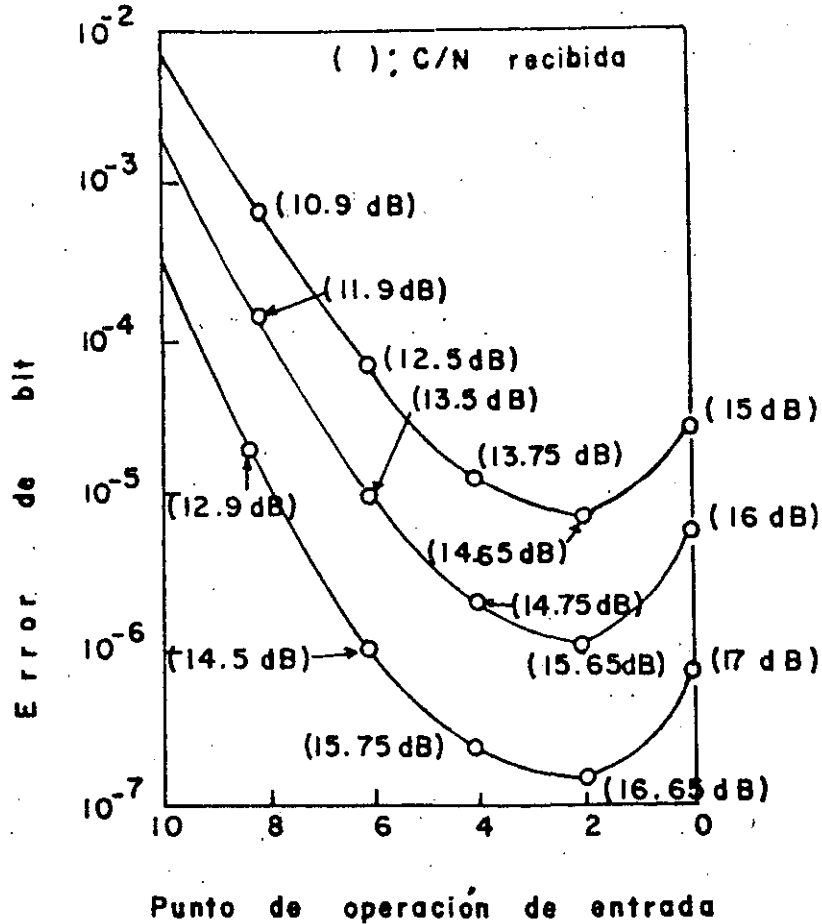


Fig (14) CARACTERISTICAS DEL ERROR DE BIT EN FUNCION DEL PUNTO DE OPERACION DEL TOP (SE SUPONE -- UNA POTENCIA DE RUIDO CONSTANTE)

La degradación del valor de error del bit debido a la no linealidad del amplificador de potencia depende de las características del filtro. En el caso del ejemplo dado en la fig.(14), en el cual se emplea la combinación de la forma del espectro y el 20 % de un filtro de raíz coseno como un filtro transmisor y el 20 % de un filtro de raíz coseno como un filtro receptor. El funcionamiento del valor del bit es mejor en un punto de operación de entrada de 2 db y la degradación de la condición

ideal es 2 db en el punto del valor de error del bit de 10^{-6} . En el sistema real, hay degradación de transmisión debido a otros factores tales como distorsión frecuencia-amplitud y distorsión por retardo. Además el funcionamiento del valor de error del bit se degrada con el proceso de demodulación no solo por la recuperación de la portadora y/o el reloj, sino también por las características no ideales del hardware.

Empleando el 40 % de un filtro de raíz coseno junto con la forma del espectro para la transmisión y un 40 % de un filtro de raíz coseno para la recepción se obtiene una degradación de 2.6 db al valor de error del bit de 10^{-6} en el cual el punto de operación de entrada del TOP del satélite y de la estación terrena se han considerado de 2 db y 14 db respectivamente.

Considerando la degradación adicional debido a la recuperación de portadora y el reloj, la distorsión incluida a lo largo de la línea de transmisión y la desviación de características debido al envejecimiento será necesario considerar un margen de 4 a 5 db comparado con el valor teórico en el punto del valor de error de 10^{-6} .

Por otro lado el margen requerido para factores externos tales como lluvia, el cual se especifica generalmente en el punto del valor de error del bit de 10^{-3} o 10^{-9} no puede determinarse únicamente debido a que depende enormemente de la banda de frecuencias empleada.

9 TRANSMISION DIGITAL DE SEÑALES DE TELEVISION

Un método PCM directo para una señal de TV cromática de ra diodifusión requiere una frecuencia de muestreo superior a los 10 Mhz y una exactitud de cuantización de 8 bits/Pel¹.

El valor de la transmisión resultante viene siendo aproximadamente de 90 Mbits/seg. y mucho mayor en algunos casos, lo cual requerirá de un ancho de banda muy grande e impráctico y puede ser muy costosa la transmisión para larga distancia. Para reducir la velocidad de transmisión se han desarrollado muchas investigaciones por mas de 25 años para lograr una codificación eficiente ó una compresión del ancho de banda de señales de TV. De estas investigaciones tenemos ahora varias técnicas de codificación tales como PCM diferencial(DPCM), códigos de transformación, ó códigos de intercuadro basado en un relleno condicional.

Actualmente se usan tres sistemas de televisión a color a nivel mundial y estos son: NTSC , PAL y SECAM. Estas señales de televisión a color estan en una forma compuestas, esto es, dos - señales de crominancia están multicanalizadas en el mismo dominio de frecuencias de una señal de luminancia.

Se han propuesto dos aproximaciones diferentes a los problemas de codificación de dichas señales compuestas de televisión a color. En la primera aproximación la señal de televisión compuesta es codificada directamente mientras que en la otra, la señal compuesta se separa en sus componentes de luminancia y crominancia y se codifican individualmente. La primera aproxima-
1 Pel - Elemento de imagen

676

670

ción se llama "Codificación Compuesta" y la segunda "Codificación de Componente".

En la aplicación usual donde la misma forma de la señal de color compuesta es necesaria en la entrada y la salida de un sistema de transmisión digital, la codificación compuesta tiene algunas ventajas sobre la codificación de componentes esto es, requiere menos complejidad en la implementación del Hardware (mecánica) y no produce degradación en la calidad de la imagen debido al proceso de codificación del color el cual es esencial en la codificación de componentes.

Las técnicas de codificación por ejemplo el DPCM ó código transformado, el cual originalmente se ha desarrollado para señales de televisión monocromática, puede aplicarse directamente a la codificación de cada señal compuesta de TV a color. También se han aplicado exitosamente a la codificación compuesta en los sistemas NTSC y PAL.

Unos de los aciertos importantes de las recientes investigaciones es el que hace posible transmitir una señal de televisión de radiodifusión a una velocidad de transmisión del nivel de la tercera gerarquía de las normas de los sistemas de transmisión digital, ó sea 44Mbits/seg. en Japon, 34 Mbits/seg. en países de Europa Central ó de un enlace de satélite digital de 20 a 30 Mbits/seg. por un canal de televisión. Otro éxito es - transmitir señales de televisión de nuevos servicios de comunicaciones tales como videoteléfono ó videoconferencias a velocidad de transmisión tan bajas como sea posible. Se han empleado

en algunos sistemas de videoconferencias codificadores de tele-
visión que trabajan a 2 ó 6 Mbits/seg. El funcionamiento de la
codificación eficiente depende inherentemente de las caracterís-
ticas de las imágenes de televisión que serán codificadas así
como el grado de movimiento ó la finesa de la textura. La tabla
(XIII) muestra objetivos provicionales para la codificación e-
ficiente en varios servicios de transmisión de televisión.

T A B L A XIII

OBJETIVOS DE VARIOS SERVICIOS DE TRANSMISION DE TELEVISION
Y VELOCIDAD DE TRANSMISION

S E R V I C I O S		VELOCIDAD DE TRANSMISION
Calidad de TV de radiodifusión		60 Mbits/s - 30 Mbits/s
TV de propositos especiales	Noticias de reunio- nes de electrónica	20 Mbits/s - 6 Mbits/s
	Videoconferencias	6 Mbits/s - 1.5Mbits/s
	Videoteléfono	1.5 Mbits/s - 64 Kbits/s

Un factor importante en los sistemas de transmisión digi-
tal para televisión es un medio de protección contra los erro-
res de transmisión. En general un PCM directo necesita un BER¹
(Valor de Error del Bit) menor de 10^{-7} para mantener una buena
calidad de imagen y una codificación de alta eficiencia , en al-
gunos casos requiere un BER menor de 10^{-9} . Así cuando el funcio-
namiento de error intrínseco de una línea digital dada es peor
que el requerido , es indispensable adoptar una sierta codifi-
1 BER - Bit Error Rate

cación de corrección de error directa (FEC)¹ para mejorar su funcionamiento de error.

10 APROXIMACION BASICA PARA REDUCCION DE LA VELOCIDAD DE TRANSMISION

Existen tres aproximaciones para reducir la velocidad de transmisión efectivamente de una señal de televisión; suprimir el período de borrado, reducción de la frecuencia de muestreo y reducción de la redundancia de las señales de imagen.

1) SUPRESION DEL PERIODO DE BORRADO.- En la codificación digital de señales de televisión, el tiempo de sincronía puede indicarse efectivamente por un corto código de sincronía de 10 a 20 bits. Por lo tanto, es posible emplear la mayor parte del período de borrado para la transmisión de elementos de imagen activos. Así esta técnica puede proporcionar un ahorro en la velocidad del bit hasta aproximadamente 20% sin ningún deterioro en la calidad de la imagen.

2) REDUCCION DE LA FRECUENCIA DE MUESTREO.- El espectro de las señales de TV no son continuas pero tienen patrones semejantes a los dientes de un peine. Utilizando esta propiedad, es posible reducir la frecuencia de muestreo bajo el límite de NYQUIST sin ninguna degradación notable en la calidad de la imagen. El empleo de $2f_{sc}$ (f_{sc} - frecuencia de subportadora de color) muestras se ha reportado para ambos sistemas el NTSC y el PAL.

3) REDUCCION DE REDUNDANCIA DE LAS SEÑALES DE IMAGEN.- Las señales de imagen de televisión contienen una cantidad considerable de redundancia estática ó perceptual². La redundancia se

1 - FEC- Forward Error Correction

2 - La redundancia perceptual implica componentes de dicha señal que no pueden ser percibidas por el ojo humano.

divide en dos categorías:

- REDUNDANCIA ESPACIAL.- La cual está contenida en un campo.

-REDUNDANCIA TEMPORAL.- La cual está contenida en una sección de campo¹. La cantidad de redundancia temporal depende del grado de movimiento de las imágenes. Es muy grande en videoteléfono ó señales de videoconferencias donde el movimiento es generalmente muy pequeño.

Se han propuesto varias aproximaciones para reducir la velocidad de transmisión. Entre ellas, el código predictivo (ó DPCM) y el código de transformación son las aproximaciones básicas y mas importantes desde un punto de vista práctico en la actualidad. Estos emplean en forma individual y algunas veces en combinación.

En sistemas de codificación predictivo básicos (ver figura 15) se hace una predicción de la muestra que será codificada de la información previamente codificada que ha sido transmitida. El error de predicción, el cual es la diferencia entre el valor de la muestra real y la predicha, se cuantiza en un conjunto de niveles de amplitud discretos por ejemplo de 10 a 30 niveles. Estos niveles se presentan en palabras binarias en cualquier longitud fija ó variable para la transmisión. Los elementos de imagen vecinos o proximos generalmente tienen una

¹ Los sistemas de TV comerciales emplean exploración entrelazada y una señal de TV está formada de campos ó la mitad de una imagen. 60 cuadros (norma de E.U o Japón) ó 50 cuadros (normas Europeas) son transmitidos cada segundo y dos campos sucesivos forman una imagen completa a la cual se le llama cuadro.

alta correlación y la Entropía del error de predicción viene a ser considerablemente menor que la de las muestras de imagen originales. Además, la reducción de la velocidad de transmisión puede lograrse en la cuantización donde se pueden utilizar las propiedades del ojo humano y también el proceso de la asignación del código usando códigos de longitud variable, por ejemplo codificación de entropía

En la forma más simple de la codificación predictiva, el valor codificado de la muestra inmediatamente anterior se usa como la predicción. Sin embargo predictores más sofisticados tales como los predictores de intercampo ó de intercuadro usan la línea previa así como el campo previo ó cuadro de información.

En la codificación de transformación una imagen se divide en subimágenes de un tamaño razonable por ejemplo 4 PELS por 4 líneas y entonces cada una de estas subimágenes se transforma en un conjunto de coeficientes estáticamente ó perceptualmente más independientes. Los coeficientes son entonces cuantizados y representados en códigos binarios para la transmisión. En el receptor los códigos recibidos son decodificados en coeficientes de transformación. Una transformación inversa se aplica a los niveles de amplitud recuperados de los elementos de imagen. Estos procesos se muestran en la fig.(16). Gran parte de la reducción de la velocidad de transmisión se logra eliminando algunos coeficientes en la transmisión cuya magnitud es pequeña así como cuantizando burdamente algunos otros coeficientes de acuerdo a la calidad de la imagen requerida.

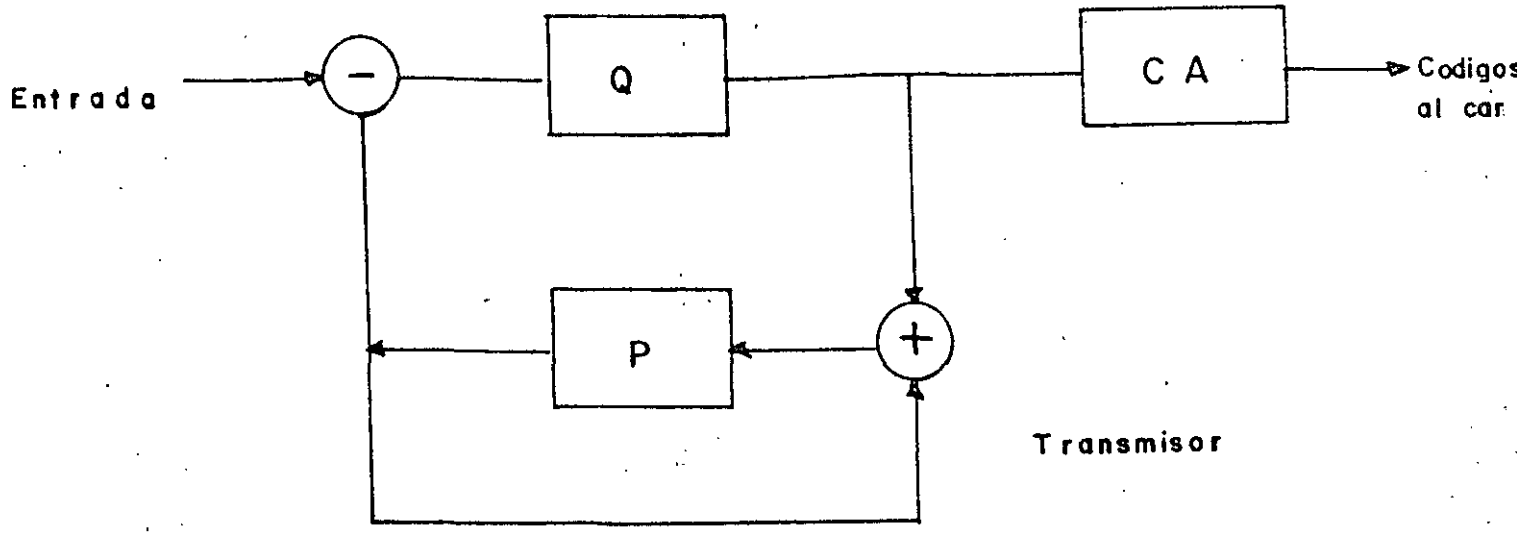
Transformadores HADAMARD y transformadores oblicuos se emplean actualmente en algunos códigos de televisión.

Estos métodos de codificación se clasifican en 3 categorías de acuerdo a que PELS son procesados para la codificación. La codificación intracampo procesa los elementos de imagen solamente dentro de un campo y la codificación intercampo procesa los elementos de imagen sobre campos adyacentes. La codificación intercuadro procesa sobre cuadros adyacentes. La codificación intracampo es simple y efectiva para reducir solamente la redundancia espacial mientras que ambas codificaciones ó sea la intercampo e intercuadro hacen posible reducir la redundancia temporal así como la redundancia espacial. Es posible por estos métodos de codificación intracampo, no obstante que requieren una mayor complejidad para la implementación de su mecánica.

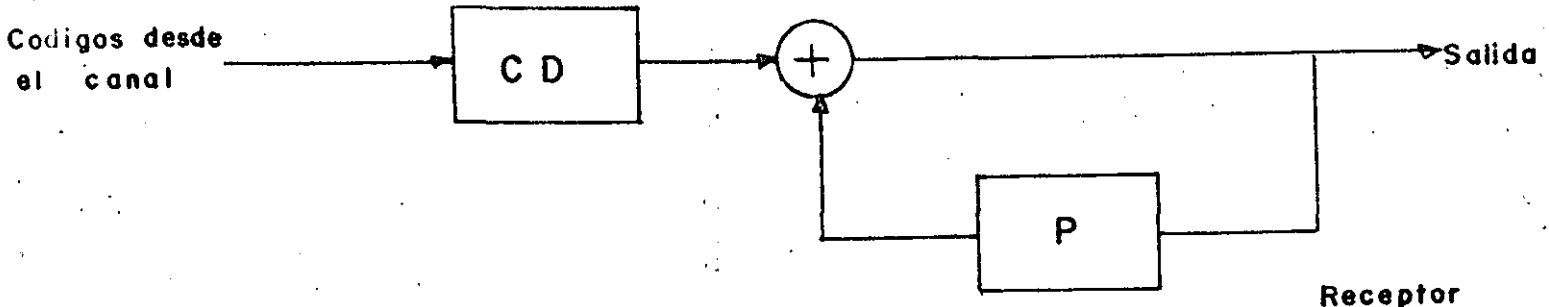
La codificación intracampo simple tal como DPCM ó el código de transformación HADAMARD pueden comprimir 8 bits/PEL ó imágenes PCM a 3 a 4 bit/pel.

Así puede transmitir una señal de televisión a color de radiodifusión con una calidad aceptable a una velocidad tan grande como 32 Mbits/seg. y con una muy buena calidad a 44 Mbits/s

Sin embargo a velocidades menores de 30 Mbits/seg es extremadamente difícil obtener una satisfactoria calidad de imagen por los simples y convencionales métodos de codificación intracampo. En dicho caso, la codificación intercampo ó intercuadro pueden ser alternativas bastante poderosas. El NETEC-22H es un ejemplo de la codificación intercuadro el cual puede transmitir



Transmisor

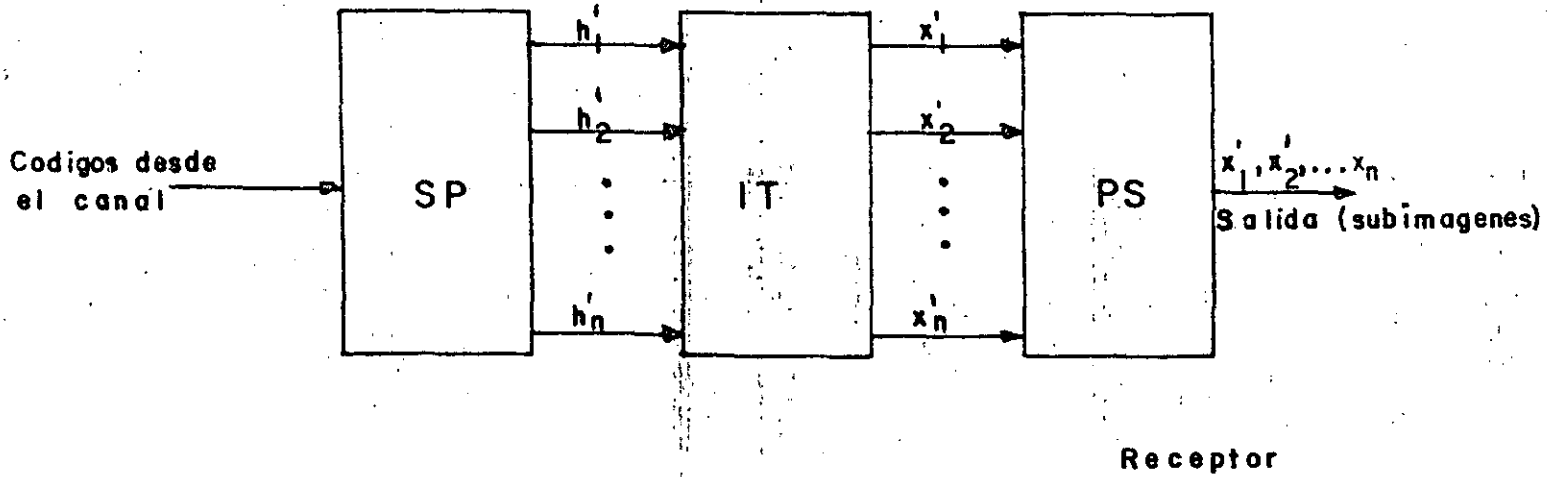
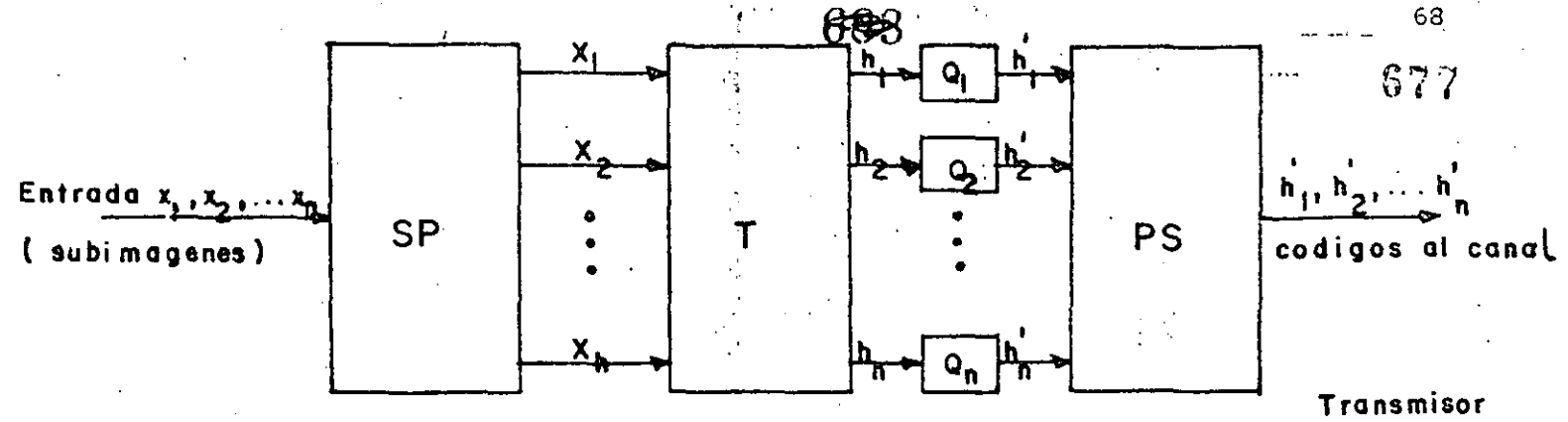


Receptor

- Q - CUANTIZADOR
- P - PREDICTOR
- CA - ASIGNADOR DE CODIGO
- CD - DECODIFICADOR DE CODIGO DE CANAL

Fig (15) DIAGRAMA A BLOQUES DE UN TRANSMISOR Y RECEPTOR

D P C M



SP - CONVERSION SERIE PARALELO

PS - CONVERSION PARALELO SERIE

Q_1, \dots, Q_n - CUANTIZADORES

x_1, \dots, x_n - VALORES EN UNA SUBIMAGEN DE ENTRADA

x'_1, \dots, x'_n - VALORES RECONSTRUIDOS DE x_1, \dots, x_n

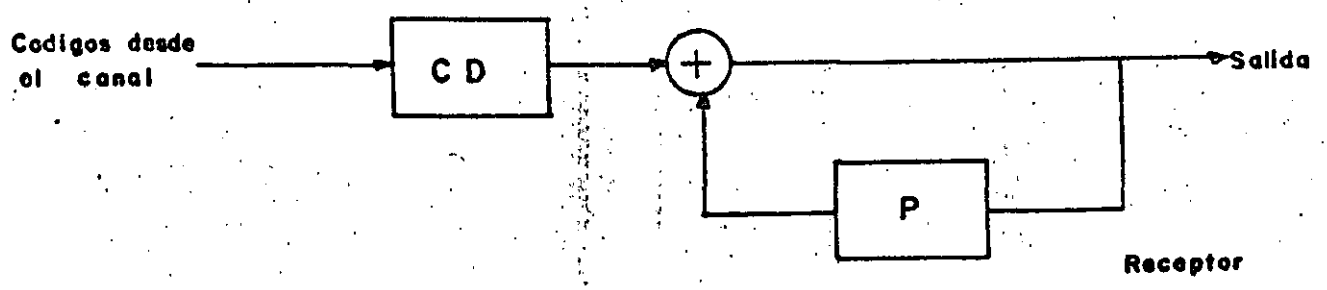
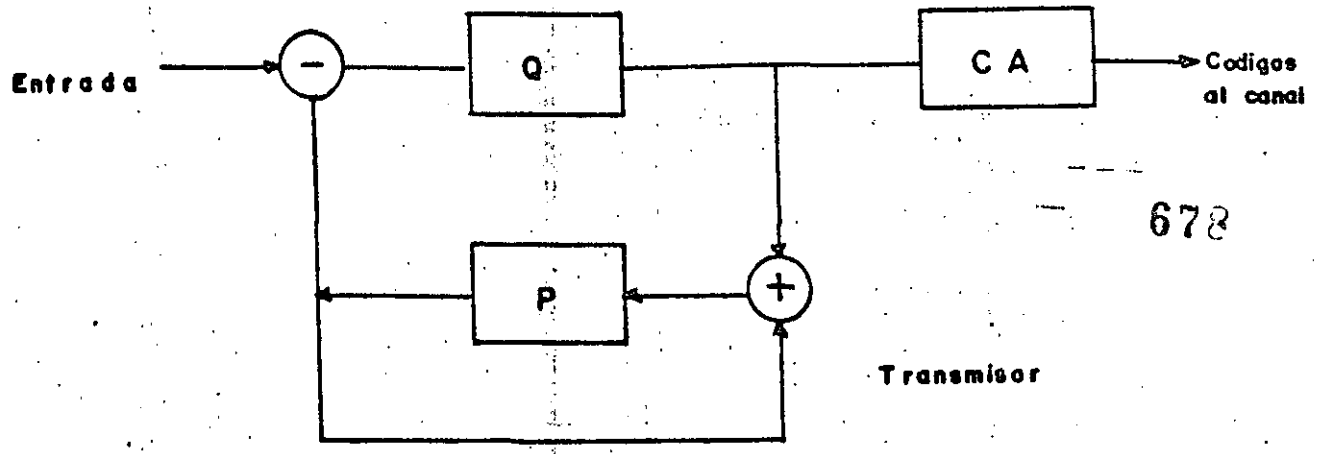
h_1, \dots, h_n - COEFICIENTES DE TRANSFORMACION

h'_1, \dots, h'_n - VERSION CUANTIZADA DE h_1, \dots, h_n

T - TRANSFORMACION

IT - TRANSFORMACION INVERSA DE T

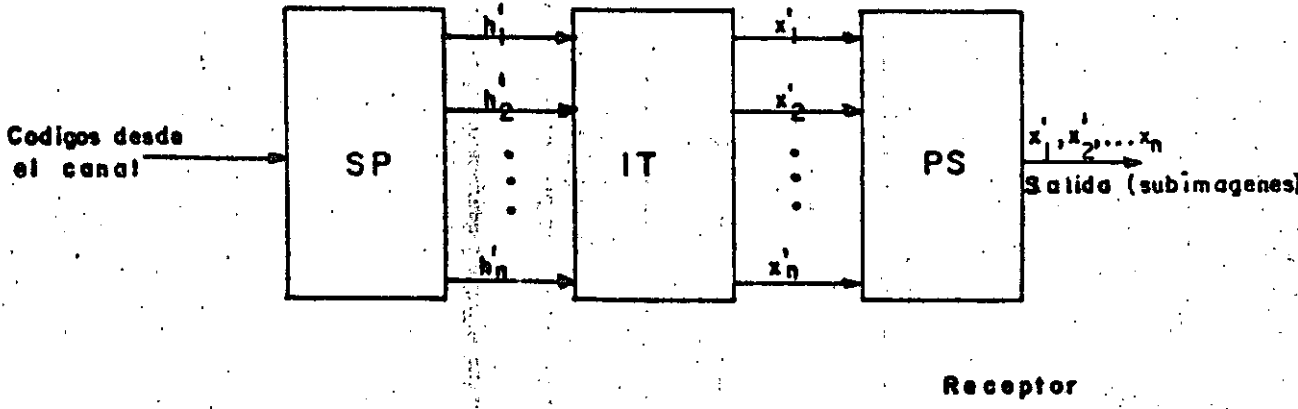
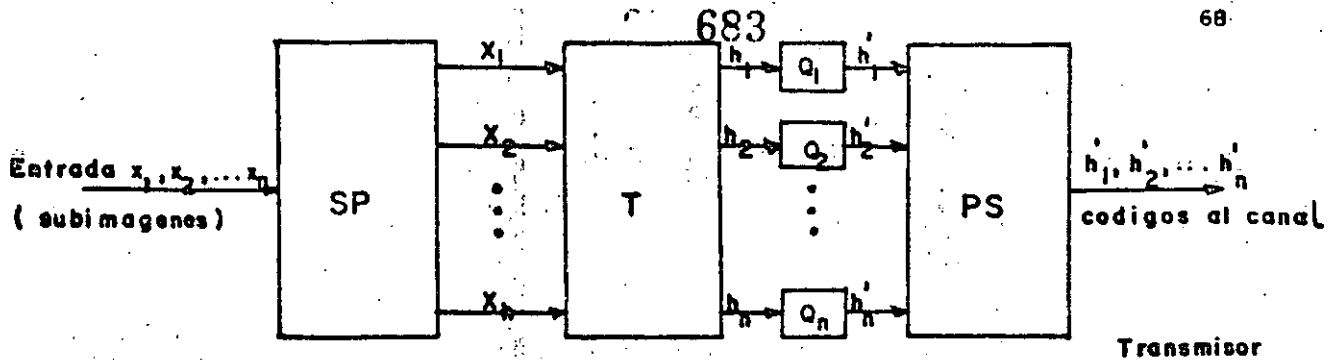
Fig (16) PRINCIPIO DE CODIGO DE TRANSFORMACION



- Q - CUANTIZADOR
- P - PREDICTOR
- CA - ASIGNADOR DE CODIGO
- CD - DECODIFICADOR DE CODIGO DE CANAL

Fig (15) DIAGRAMA A BLOQUES DE UN TRANSMISOR Y RECEPTOR

D P C M



- SP - CONVERSION SERIE PARALELO
- PS - CONVERSION PARALELO SERIE
- Q_1, \dots, Q_n - CUANTIZADORES
- x_1, \dots, x_n - PEl EN UNA SUBIMAGEN DE ENTRADA
- x'_1, \dots, x'_n - VALORES RECONSTRUIDOS DE x_1, \dots, x_n
- h_1, \dots, h_n - COEFICIENTES DE TRANSFORMACION
- h'_1, \dots, h'_n - VERSION CUANTIZADA DE h_1, \dots, h_n
- T - TRANSFORMACION
- IT - TRANSFORMACION INVERSA DE T

Fig (16) PR INICIO DE CODIGO DE TRANSFORMACION

una señal de televisión de radio difusión a 30 y 20 Mbits/seg.

La codificación decodificación (CODEC) intercambio a 30 - Mbits/seg. que emplea predicción adaptiva intercambio-intracampo es otro ejemplo de los codex de televisión a color desarrollados recientemente para los enlaces de satélites digitales.

La codificación intercuadro es muy efectiva para la transmisión de señales de televisión de videoteléfono ó videoconfe - rencias a una velocidad de transmisión del orden de 6 a 1.5 - Mbits/seg.

11. EJEMPLO DE CODIFICACION-DECODIFICACION DE TELEVISION DE ALTA EFICIENCIA PARA ENLACES DE SATELITE DIGITALES.

A la fecha se han reportado muchos CODECS digitales de alta eficiencia, algunos de los cuales se han probado en enlaces de satélites digitales actuales. En esta sección se describe un CODEC intercambio de 30 Mbits/seg. para señales de TV a color - NTSC el cual ha sido desarrollado recientemente.

Este CODEC se diseñó con el propósito de transmitir 2 programas de TV de radiodifusión simultáneamente a través de un solo transponder de 36 MHz que emplea el satélite INTELSAT IV. El transponder permite una transmisión de un tren digital de 60 - Mbits/seg. con modulación PSK de cuatro fases. Por lo tanto la velocidad de transmisión asignada a un canal de TV es de 30 Mbit /seg., la cual puede incluir uno ó dos canales de voz así como

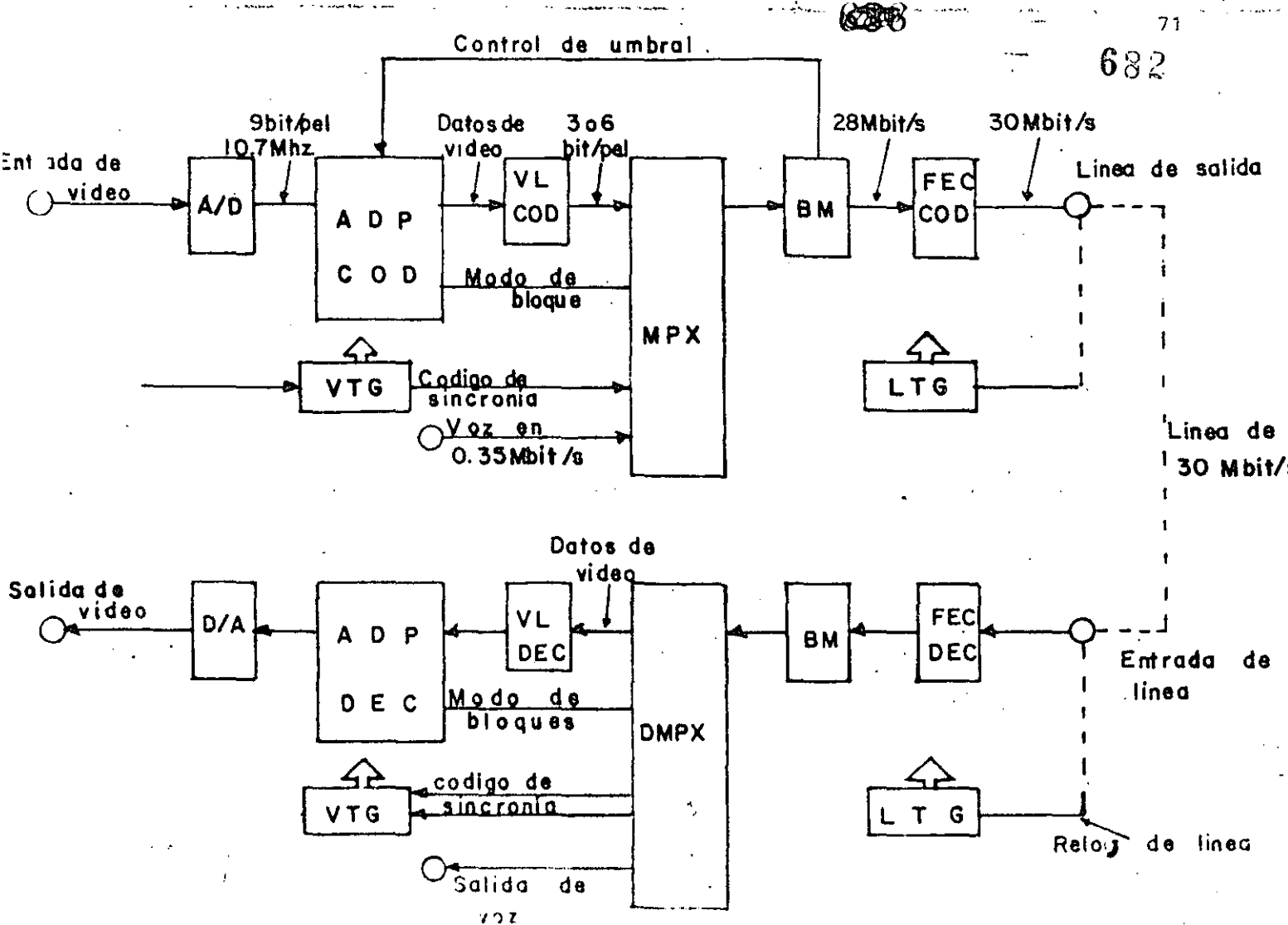
transmisión neta permitida para un canal de video debe ser menor de 28 Mbits/seg.

Para dicha velocidad de transmisión, las técnicas de codificación intracampo convencionales tales como DPCM ó la codificación de transformación no pueden lograr una suficiente calidad de imagen para programas de radiodifusión de TV. Para lograr una calidad satisfactoria, los CODECS actuales adoptan un método de codificación más avanzado; por ejemplo la codificación de predicción adaptiva emplea dos tipos de predictores de señal de color compuesta. Esta aplicación adaptiva de los predictores intracampo e intercampo logran una predicción muy buena y estable para practicamente todas las clases de imágenes, aún las que contienen un movimiento muy violento.

En la fig.(17) se muestra un diagrama a bloques de un CODEC intercampo.

Este CODEC codifica directamente la señal compuesta de TV cromática NTSC. En otras palabras, desarrolla la codificación compuesta como se ilustra en la fig.(17) una señal de entrada de TV primeramente se muestrea a una velocidad de tres veces la frecuencia de la subportadora de color (alrededor de 10.7 MHz) y se cuantiza linealmente a 9 bits/Pel. La señal digitalizada se aplica entonces al codificador de predicción adaptiva el cual incorpora el predictor intracampo P1 y el predictor intercampo P2.

Los predictores se expresan por:



ADPCOD - Codificador de Prediccion Adaptivo Intercampo e Intracampo

ADPDEC - Decodificador de Prediccion Adaptivo Intercampo e Intracampo

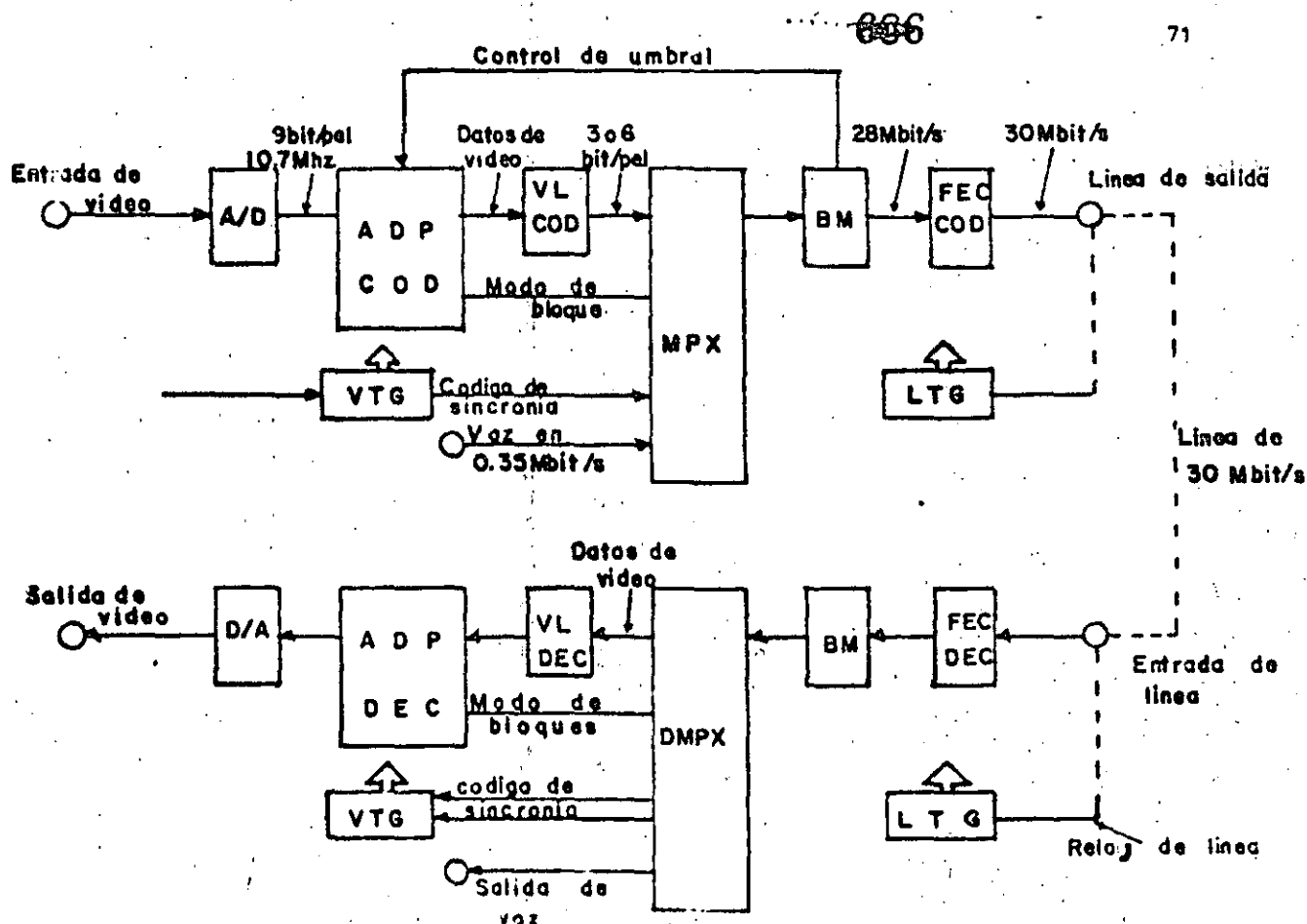
VLCOD - Codificador de Longitud Variable de 3 a 6 Bits

VLDEC - Decodificador de Longitud Variable de 3 a 6 Bits

FEECOD- Codificador de Corrección de Error Directo

FECDEC- Decodificador de Corrección de Error Directo

Fig (17) DIAGRAMA A BLOQUES DE UN CODEC INTERCAMPO



ADPCOD - Codificador de Predicción Adaptivo Intercampo e Intracampo

ADPDEC - Decodificador de Predicción Adaptivo Intercampo e Intracampo

VLCOD - Codificador de Longitud Variable de 3 a 6 Bits

VLDEC - Decodificador de Longitud Variable de 3 a 6 Bits

FECOD- Codificador de Corrección de Error Directo

FECDEC- Decodificador de Corrección de Error Directo

Fig (17) DIAGRAMA A BLOQUES DE UN CODEC INTERCAMPO

Las expresiones anteriores se representan en función de la transformada Z, donde L indica el número de Pels en una línea de exploración.

Estos dos predictores operan simultáneamente y sus errores de predicción se comparan por bloques.

Específicamente, los valores absolutos de los errores de predicción por cada 8 Pels sucesivos en una línea de exploración los cuales se consideran como un bloque se aplican a cada predictor, y se escoge el predictor que proporcione la suma más pequeña como el efectivo para el bloque considerado.

La suma de errores, dados por el predictor escogido, se compara entonces con un cierto valor de umbral. Si es mayor que el umbral, el bloque se considera significativo y si es menor se considera insignificante. Solamente se cuantizan y transmiten los errores de predicción de los bloques significantes. En el receptor, la señal de imagen de TV se reconstruye integrando las señales de error de predicción transmitidas. Los errores de predicción para los bloques insignificantes no se consideran en la reconstrucción de la señal.

El nivel del umbral no varía de acuerdo al contenido de la memoria del (BUFFER). Esto es, cuando una gran cantidad de errores de predicción excede un nivel de umbral específico y el contenido de memoria (BUFFER) se incrementa, el nivel de umbral se eleva para suprimir la ocurrencia de bloques significantes. Cuando se producen menos bloques significantes disminuye el nivel de umbral. Así, el valor de ocurrencia de datos se mantiene a

un promedio de aproximadamente 27.7 Mbits/seg.

Los errores de predicción se cuantizan en 13 niveles y se codifican en palabras de código de 3 a 6 bits como se muestra en la tabla (XIV).

Los datos de cuatro líneas de cada campo se transmiten en PCM de 9 bits, para colocar los valores iniciales de los predictores en el receptor: Se toman dos líneas de la parte superior de cada campo para el predictor de intracampo, y las otras dos líneas se toman de la parte inferior de cada campo para el predictor intercampo. Cada 10 seg., la predicción intracampo es adoptada únicamente durante un periodo de campo. Este método trabaja eficientemente para recuperar imágenes normales que se encuentran deterioradas debido a los errores de transmisión.

TABLA XIV
CARACTERÍSTICAS DE CUANTIZACIÓN

NIVEL DE ENTRADA	NIVEL DE SALIDA	CODIGO
- 136 a - 511	-192	101101
- 58 a - 135	- 79	101111
- 27 a - 57	- 36	101110
- 13 a - 26	- 17	111
- 6 a - 12	- 8	100
- 2 a - 5	3	110
1 a - 1	0	010
2 a - 5	3	011
6 a 12	8	000
13 a 26	17	001
27 a 57	36	101011
58 a 135	79	101010
136 a 511	192	101000

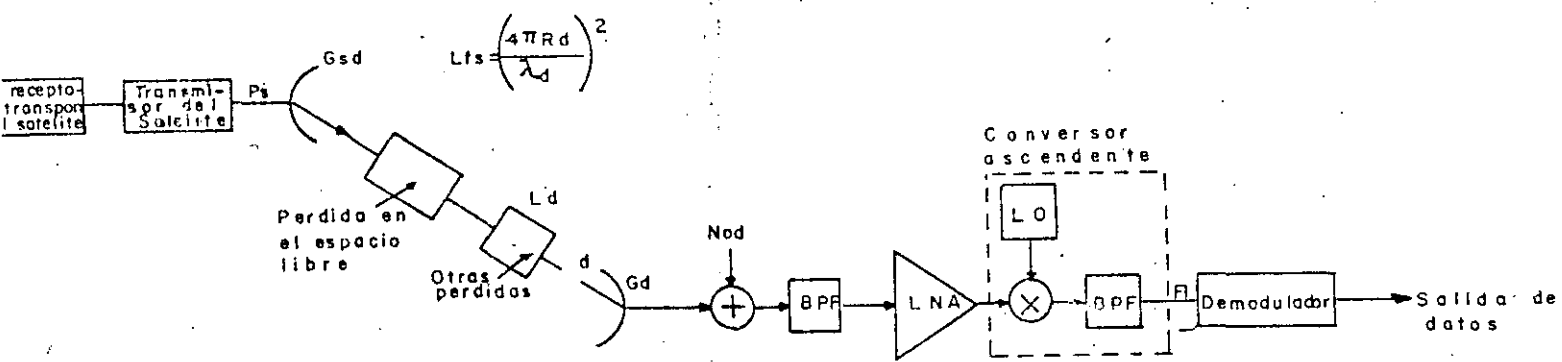
Para cada dos líneas en el punto de partida del periodo de borrado horizontal (HBL) se incerta un código de sincronía de 18 bits. Se transmite antes de los datos de imagen de las 2 líneas requeridas, incluyendo todas las muestras en HBL.

Así, este CODEC completa la reproducción de una señal de televisión que está llegando. El código de sincronía de 18 bits está diseñado de tal forma que su ausencia debido a los errores de transmisión puede ser menor de 1 en 10 min. para una transmisión efectiva con un valor de error del bit de 10^{-5} .

El código con doble corrección de error (BCH) se emplea para corrección de error directa (FEC) el cual puede mejorarse, por ejemplo con un error de bit de 10^{-4} a 10^{-7} y de 10^{-5} a 10^{-10} respectivamente. El código FEC cuyo ancho de banda es de 2Mbits/seg. y los datos de voz de 0.35 Mbits/seg. se suman a la señal de televisión para dar la velocidad de transmisión total (ancho de banda relativo) de 30Mbits/seg.

La calidad de la imagen es satisfactoria para toda escena, incluyendo a aquellas que tienen movimientos muy violentos, el efecto de acercamiento y alejamiento de la cámara (zoom) y los cambios de escena. La única excepción es un pequeño número de imágenes que tienen una gran cantidad de textura extremadamente fina con alto contraste que se mueven lentamente donde se percibe cierta cantidad de ruido de codificación. La calidad se estima en 4.5 en una escala de deterioro de 5 puntos para una prueba de evaluación subjetiva formal especificada por la recomendación 500 del CCIR.

de transmisión efectiva, por ejemplo de un valor de error corregido por la codificación FEC inferior a 10^{-9} para lograr una degradación de imagen despreciable debido a errores de transmisión. Un error efectivo de 10^{-8} es un valor crítico de umbral requerido para obtener una calidad de transmisión aceptable. En resultados de pruebas de propagación en un satélite INTELSAT IV que emplea este CODEC intercampo, muestran que, bajo condiciones normales de operación del INTELSAT IV en la estación terrestre donde el valor de error del canal es menor de 10^{-6} y el valor efectivo es menor de 10^{-13} , la influencia de los errores de transmisión es completamente imperceptible y la calidad de la imagen es evidentemente un poco mejor que la transmisión en FM empleando un medio transponder (17.5 MHz de ancho de banda) empleados actualmente en algunos sistemas de comunicación por satélite. (Ejemplo los satélites INTELSAT).



c)

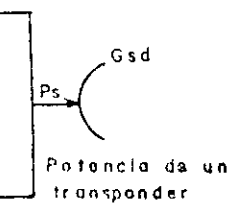
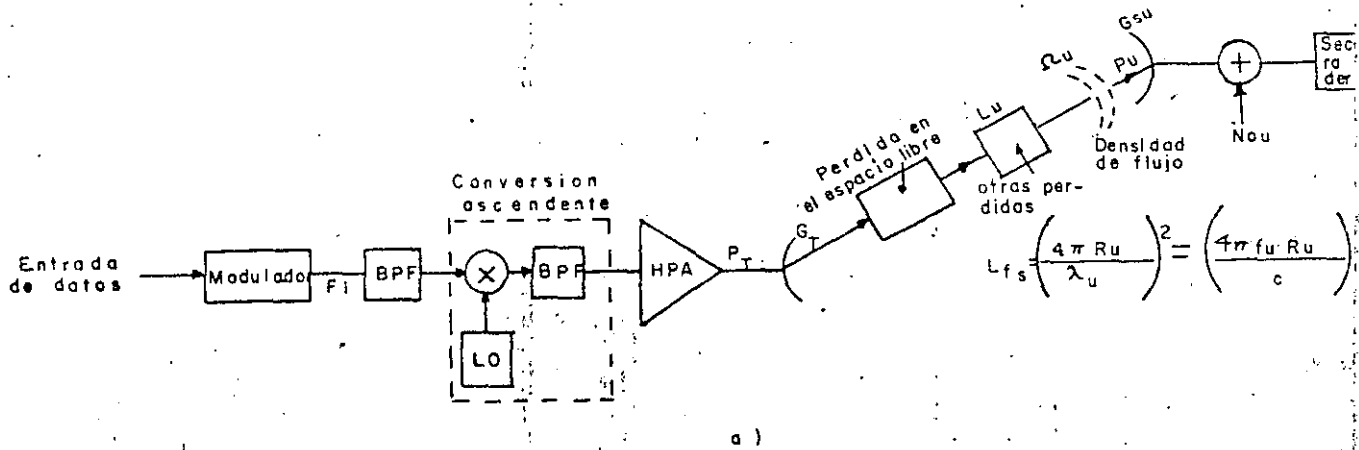
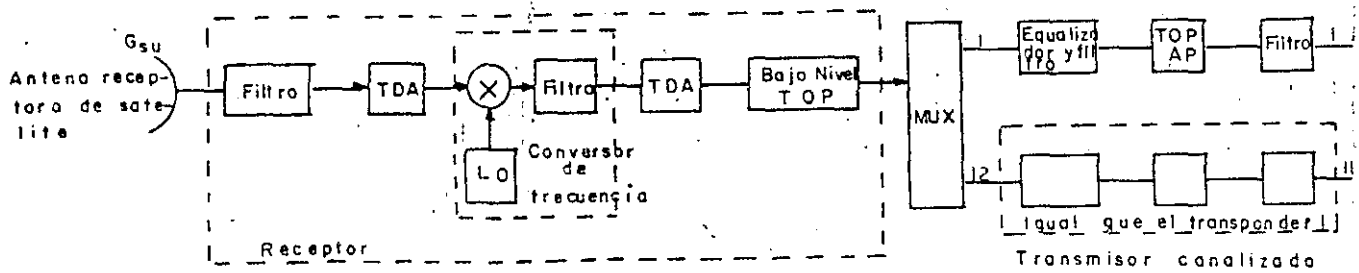


Fig (18) a) Modelo ascendente b) Transponder del satélite c) Modelo descendente.



a)



b)

- Asu - Área efectiva de la antena receptora del satélite (ascendente).
- BPF - Filtro pasa banda.
- C - Velocidad de la luz 2.99×10^8 m/seg.
- f_u - Frecuencia de portadora ascendente.
- G_d - Ganancia de la antena receptora de la estación terrena.
- G_{Sd} - Ganancia de la antena de transmisión del satélite (descendente).
- G_{Su} - Ganancia de la antena de recepción del satélite (ascendente).
- G_T - Ganancia de la antena transmisora de la estación terrena.
- HPA - Amplificador de alta potencia.
- IF - Frecuencia intermedia (típicamente $70\text{MHz} \pm f$ ó $140\text{MHz} \pm f$).
- L_{fs} - Pérdidas en el espacio libre (dispersión).
- L_o - Oscilador local.
- L_u, L_d - Otras pérdidas ascendentes (descendentes) (tales como el factor de eficiencia de la antena, pérdidas atmosféricas).
- MUX - Red de multicanalización (en este caso, una red de R.F.)
- N_{ou}, N_{od} - Densidad espectral del ruido ascendente (descendente).
- P_u - Potencia de la señal recibida por el satélite.
- AP - Amplificador de potencia.
- P_s - Potencia transmitida por un transponder del satélite.
- P_T - Potencia transmitida por el amplificador de alta potencia de la estación terrena.
- R_u - Distancia ascendente en metros de la tierra al satélite.
- TDA - Amplificador a diodo TUNNELL.
- TCP - Amplificador a tubo de onda progresiva.
- λ_d - Longitud de onda ascendente (descendente).
- η_u - Densidad de flujo de recepción en el satélite.

12 PARAMETROS DEL SISTEMA

12.1 DEFINICIONES

12.1.1 POTENCIA DE TRANSMISION P_p Y ENERGIA DEL BIT E_b . - Los amplificadores típicos de alta potencia de una estación terrena (HTA) y los amplificadores de los satélites de TOP son dispositivos no lineales. La razón de la potencia de salida a la potencia de entrada (ganancia) depende del nivel de excitación de entrada. La figura (18) muestra características típicas de fase y potencia de entrada y salida.

Para obtener una operación eficiente el diseñador debe intentar operar a los amplificadores de potencia (que se encuentran en la estación terrena y en el transponder) muy próximos al punto de saturación. Desafortunadamente las características de ganancia no lineal y de fase de estos dispositivos degradan la calidad de los sistemas modulados. Así pues, se requiere una solución con un cierto compromiso. Llamémosle P_{osat} a la potencia de salida saturada. En este caso la energía promedio del bit transmitido es;

$$E_b = P_{osat} T_b \quad \text{----- (38)}$$

Donde:

T_b - Duración del bit.

De la figura (19) observamos que un punto de operación de entrada a 6db (se requiere una potencia de entrada inferior a 6 db para llevar al amplificador a saturación) origina un punto de operación de salida de 2 db. Así, es evidente una comparaci-

ción de potencias.

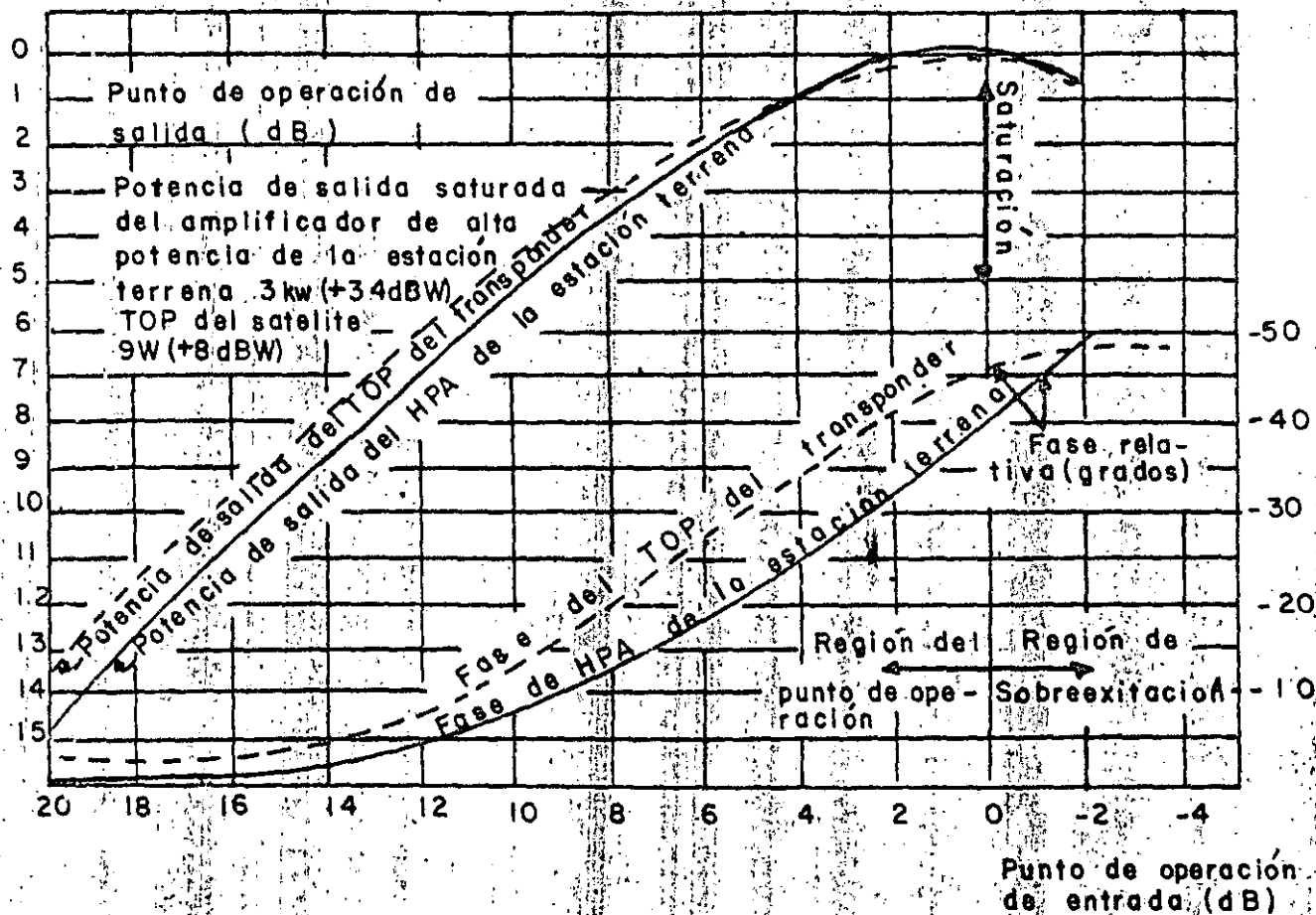


Fig (19) Características de amplitud y fase de un HPA de una estación terrena típica y el TOP del transponder de un satélite empleado en el sistema INTELSAT -V-TDMA 6/4 GHz.

12.1,2 ANTENA ISOTRÓPICA.- Una antena isotrópica es una antena ideal sin pérdidas la cual irradia igual potencia en todas direcciones. Una antena isotrópica no puede construirse y solamente se puede aproximar en la práctica. Sin embargo para estudios de sistemas por satélite es conveniente emplear la antena isotrópica como referencia para hacer una comparación con las antenas

reales. La antena isotrónica tiene una ganancia en potencia - igual a 1. Para esta antena la radiación en cualquier dirección es constante y está dada por:

$$\text{INTENSIDAD DE RADIACION DE UNA ANTENA ISOTROPICA} = \frac{P}{4\pi} \quad \text{-----} \quad (39)$$

Donde:

P - Potencia de entrada

12.1.3 GANANCIA DE UNA ANTENA.- El incremento de potencia relativo logrado por enfocar la antena se define como la ganancia de la antena, es decir es la habilidad de una antena para concentrar la energía electromagnética en un punto determinado y se define como:

$$G = \frac{\text{INTENSIDAD DE RADIACION MAXIMA}}{\text{INTENSIDAD DE RADIACION DE UNA ANTENA ISOTROPICA}} \quad \text{-----} \quad (40)$$

suponiendo la misma potencia de entrada.

También se puede definir como:

$$G = \frac{\text{POTENCIA RECIBIDA DESDE LA ANTENA DEL RECEPTOR}}{\text{POTENCIA QUE RECIBIRIA EL RECEPTOR SI LA TRANSMISION FUERA ISOTROPICA}} \quad \text{-----} \quad (41)$$

empleando las ecuaciones (39) y (41) tenemos

$$G = \frac{4\pi (\text{INTENSIDAD DE RADIACION MAXIMA})}{P} \quad \text{-----} \quad (42)$$

La ganancia aproximada para una antena parabólica se representa por la siguiente expresión:

$$G = \eta \left(\frac{\pi D}{\lambda}\right)^2 = \frac{4\pi f^2 A_p}{c^2} \quad \text{-----} \quad (43)$$

Donde:

η - Eficiencia de la antena (0.5 a 0.8) típicamente 0.54

D - Diámetro de la antena

A_e - Area efectiva de la antena transmisora = $\frac{D^2 \cdot \pi}{4}$

La figura (20) nos representa un nomograma para el cálculo de la ganancia de una antena parabólica a diferentes frecuencias y en función del diámetro.

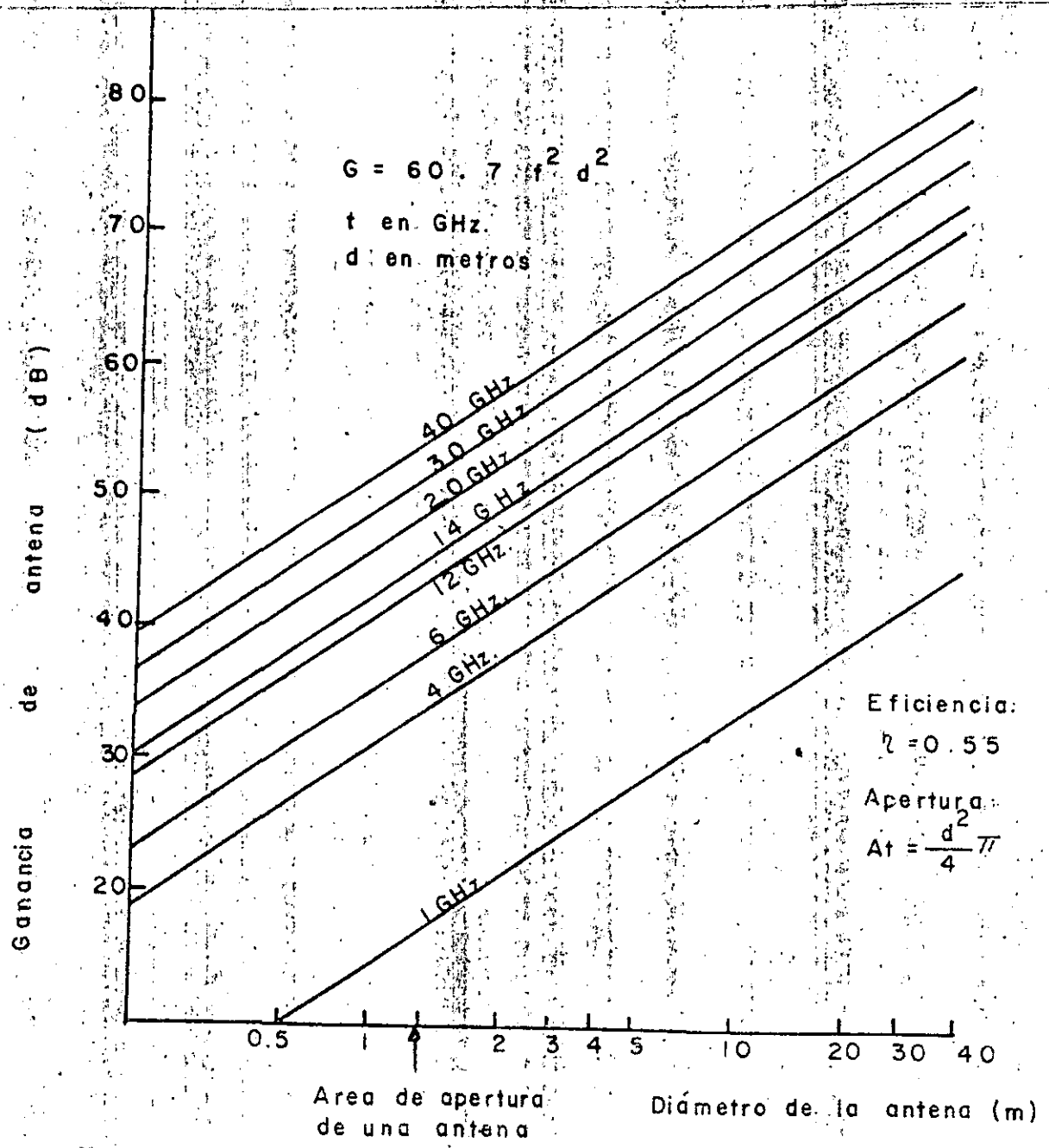


Fig. (20) Ganancia

12.1.4 POTENCIA RADIADA ISOTROPICA EFECTIVA (EIRP).- La potencia radiada isotrópica efectiva de una estación terrena o de un transponder puede expresarse como:

$$EIRP = P \cdot G \quad (44)$$

6

$$EIRP = P(\text{dbw}) + G(\text{db})$$

Donde:

P - Potencia transmitida de la estación terrena ó potencia transmitida del amplificador de alta potencia del transponder.

Ejemplo: La potencia de salida saturada de un amplificador de una estación terrena es de 2 Kw (33 dbw). El diámetro de la antena de la estación terrena es de 15 m. La frecuencia de transmisión es de 14 GHz. Se desea conocer la EIRP saturada de la estación terrena. Supongase que la pérdida por el punto de operación de salida y de combinación son iguales a 7 db.

Aplicando la ecuación (43) y considerando una eficiencia de 0.55 tenemos:

$$G = 0.55 \left(\frac{15}{0.021} \right)^2 = 2659858.4$$

$$G = 10 \log (2659858.4)$$

$$G = 64.24 \text{ db}$$

POTENCIA DE SALIDA SATURADA 33 dbw

GANANCIA D. LA ANTENA 64 db

PERDIDAS POR COMBINACION Y PUNTO DE OPERACION - 7 db

EIRP 90 dbw

~~699~~

Esta es una EIRP típica para satélites de comunicaciones EUROPEOS y para estaciones terrenas INTERSAT-V- TDMA

12.1,5 PERDIDA POR TRAYECTORIA EN EL ESPACIO LIBRE.- La pérdida de potencia de una onda de radio en el espacio es:

$$L_{fs} = (4\pi R / \lambda)^2 = (4\pi fR / C)^2 \text{ ----- (45)}$$

Donde:

R - Distancia viajada en el espacio; para un ángulo de elevación de 90° esta distancia es 3.593×10^7 m. o sea - aproximadamente igual a 3.6×10^4 km.

$$L_{fs} = 32.4 + 20 \log (f \text{ MHz}) + 20 \log (R \text{ km.}) \text{ ---- (46)}$$

La pérdida en el espacio libre en función de la frecuencia se muestra en la figura (21)

700

697

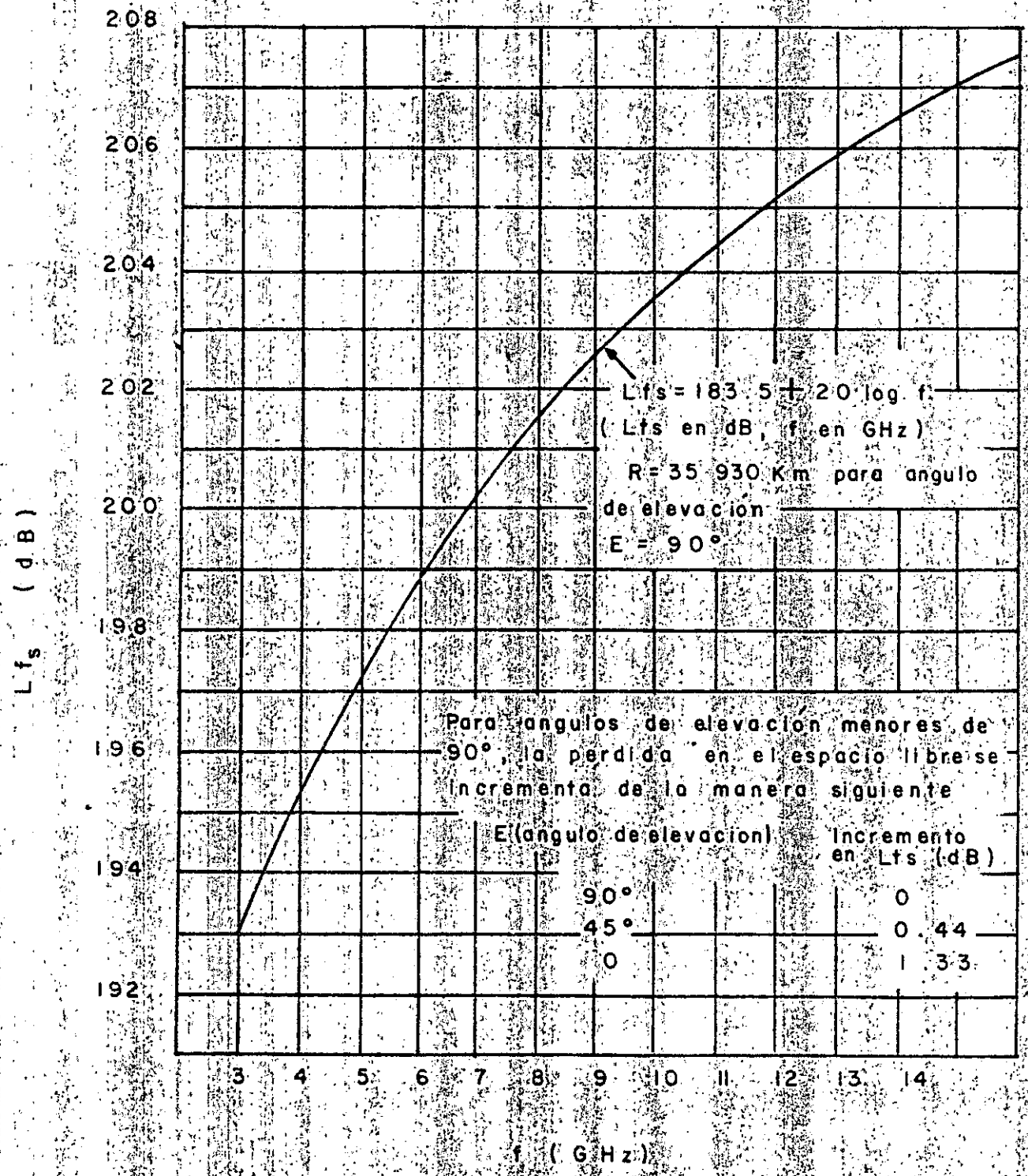


Fig. (21) Pérdida por trayectoria en el espacio libre.

Existen también pérdidas por absorción debido al oxígeno, vapor de agua, lluvia, nieve, niebla, etc. Este efecto se ilustra en la gráfica de la figura (22)

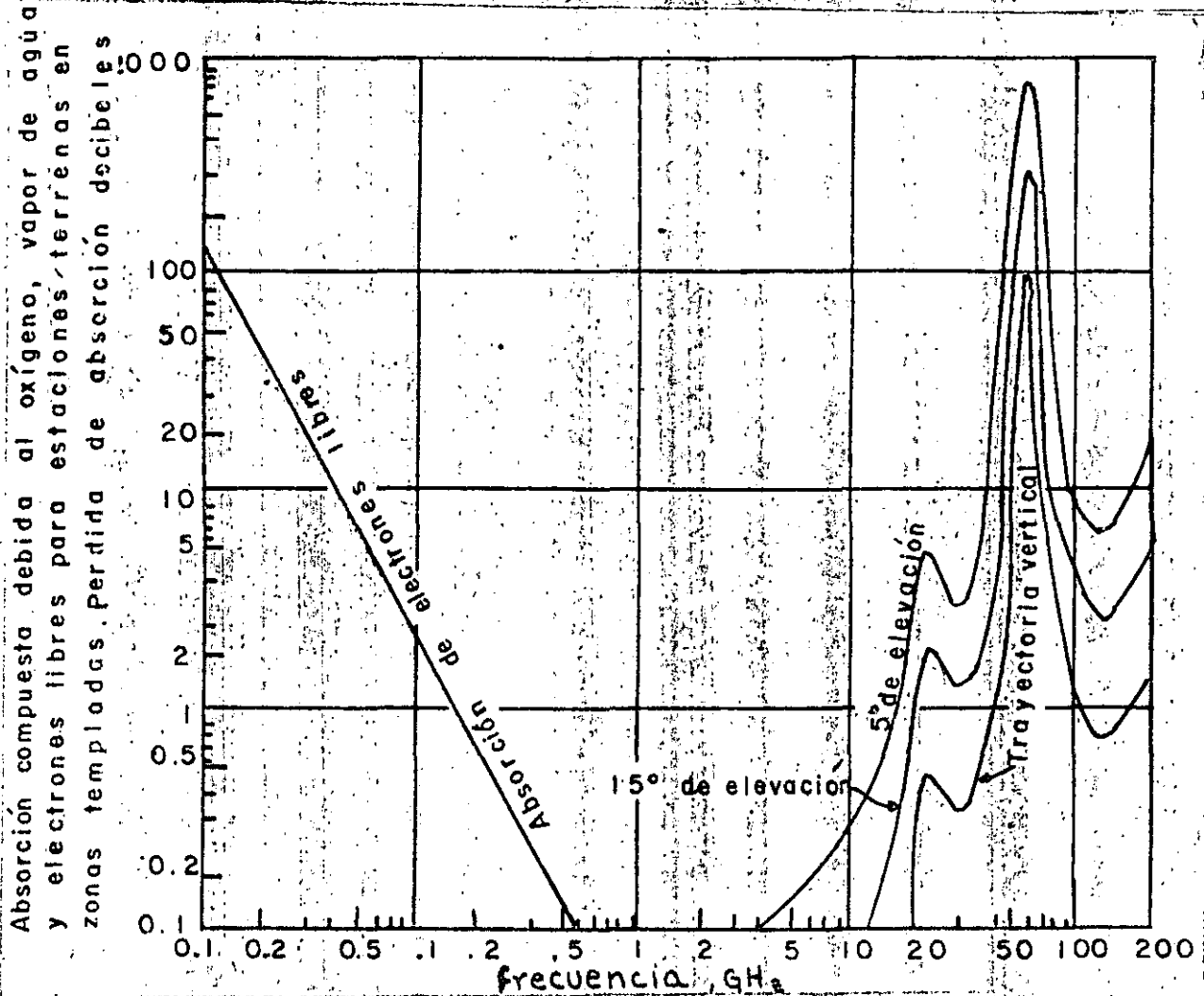


Fig. (22). Absorción en la atmósfera originada por electrones libres, oxígeno molecular y vapor de agua no condensada.

La distancia desde una estación terrena al satélite también como distancia oblicua que se puede representar como:

$$R = \sqrt{(h + r_e)^2 + r_e^2 - 2r_e(h + r_e) \cos \theta}^{1/2} \quad (47)$$

Donde:

h , r_e y θ se definen de acuerdo a la figura (23)

702

699

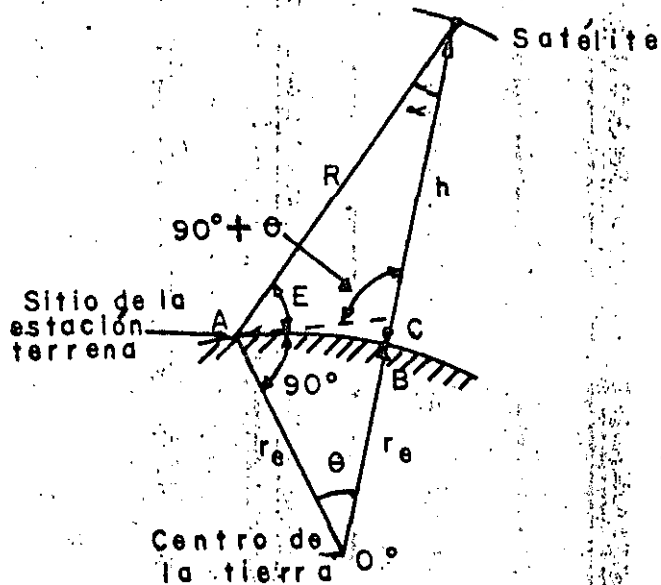


Fig (23) Distancia oblicua, central y ángulos de elevación (órbita geostacionaria) r_e - Radio de la tierra (6378 km) h - altura del satélite (35970 km) $r_e + h$ - (42230 km) R - distancia oblicua, E - ángulo de elevación, θ - ángulo central, $90^\circ + \theta$ - ángulo Nadir.

12.1.6 TEMPERATURA DE RUIDO, T_n Y FIGURA DE RUIDO (NF). - En sistemas de microondas terrestres la potencia del ruido generado por el equipo o más generalmente en los sistemas de transmisión, -- está especificado en términos de la figura de ruido (NF). En enlaces por satélite se requiere frecuentemente calcular y verifi

~~703~~

700

car experimentalmente la cantidad de ruido dentro de una fracción de 1 db. Esto se hace así porque en un sistema de comunicación de satélites que tienen numerosas estaciones terrenas, el error de 1 db. en los calculos del enlace y en las características del sistema puede resultar muy costoso. Para fuentes de bajo ruido la temperatura de ruido equivalente (T_e), proporciona un parámetro del sistema mas práctico que la figura de ruido. Por esta razón este término es más empleado en comunicaciones por satélite.

12.1,7 FIGURA DE RUIDO.- Una definición de la figura de ruido es:

$$NF = \frac{N_{\text{práctico}}}{N_{\text{ideal}}} = \frac{N_{\text{práctico}}}{k T_o W A} \quad (48)$$

Donde:

W - Ancho de banda de ruido lateral doble del sistema que se evalúa.

A - Ganancia del sistema que se evalúa

k - Constante de BOLTZMAN 1.38×10^{-23} W-seg/K = -198.6 dbm/K-Hz

T_o - Temperatura del medio ambiente en la cual se desarrolla la medición (a temperatura ambiente $T_o = 293K$)

Un diagrama a bloques en el cual se ilustre la medición de la figura de ruido se muestra en la figura (24) donde se ilustran los puntos de medición de los parámetros de la ecuación (48). Para un conjunto práctico de la medición de la figura de ruido es suficiente tener un amplificador de referencia el cual tenga una figura de ruido considerablemente mas baja que la del amplificador que está siendo evaluado.

701

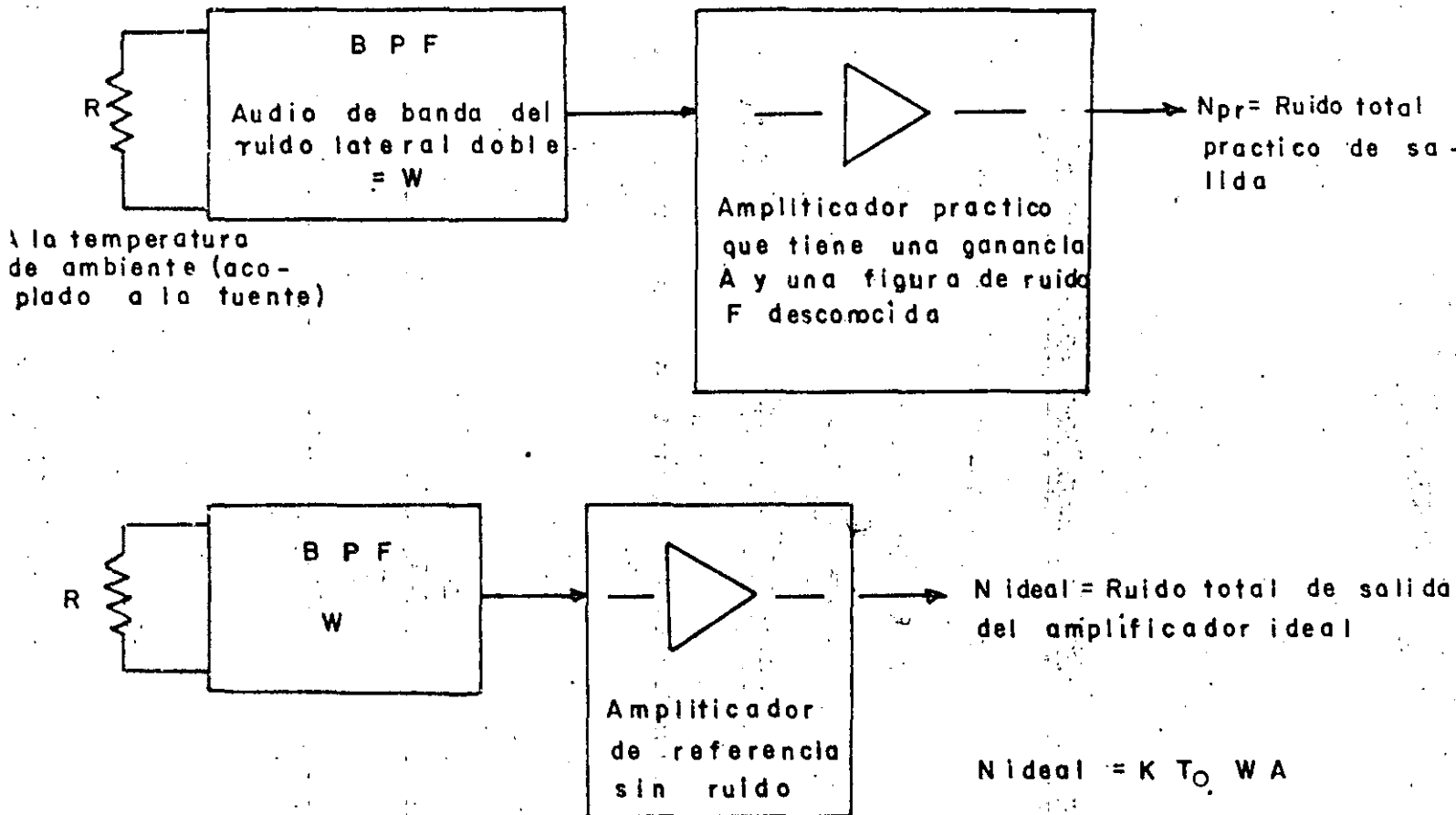


Fig. (24) CONJUNTO PARA MEDIR LA FIGURA DE RUIDO

12.1,8 TEMPERATURA DE RUIDO T_0 . - Si una fuente ruidosa genera una potencia de ruido representada por N , su temperatura de ruido equivalente, T_0 está definido por:

$$T_0 = \frac{N}{K W} \quad (49)$$

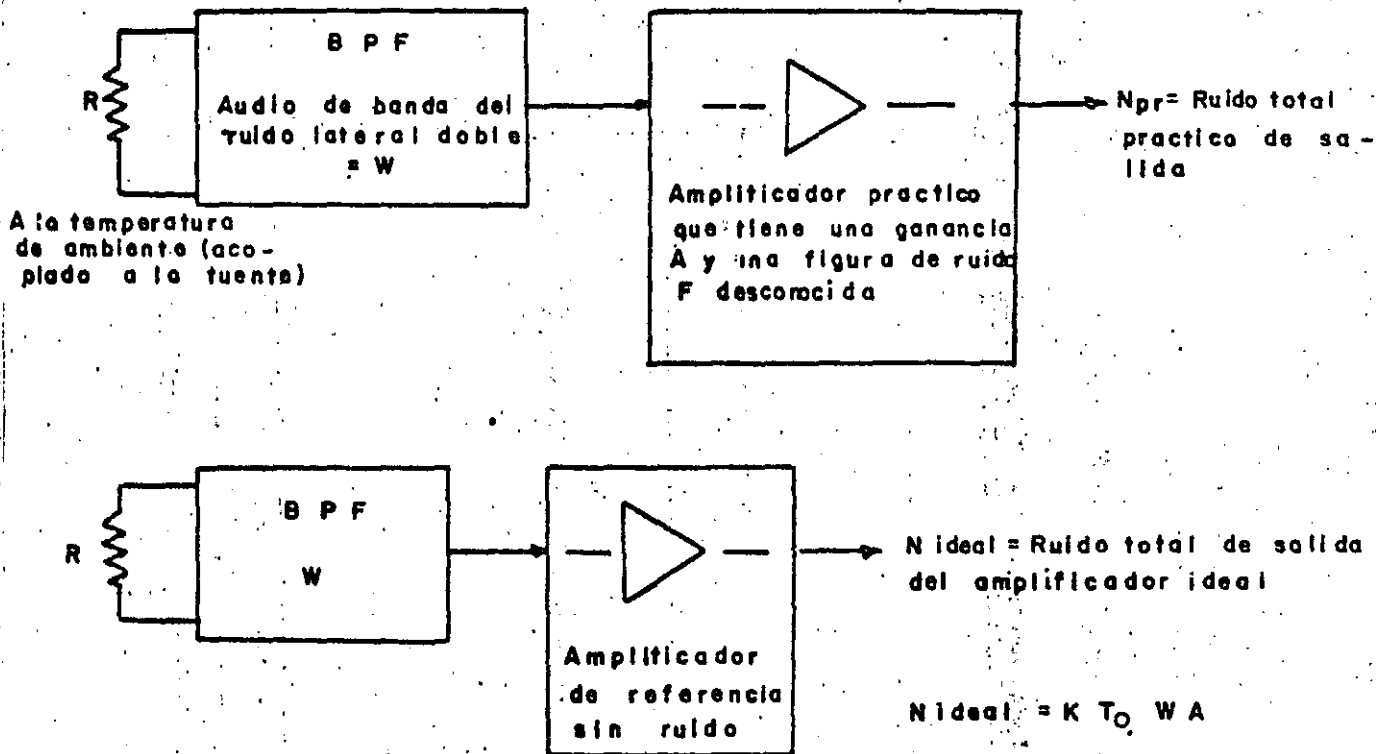


Fig. (24) CONJUNTO PARA MEDIR LA FIGURA DE RUIDO

12.1,8 TEMPERATURA DE RUIDO T_e .- Si una fuente ruidosa genera una potencia de ruido representada por N , su temperatura de ruido equivalente, T_e esta definido por:

$$T_e = \frac{N}{K W} \quad (49)$$

La potencia de ruido a la salida de un receptor que tiene un ancho de banda de ruido W' , una ganancia A y una temperatura de ruido equivalente T_e puede representarse como:

$$N_{\text{práctico}} = \underbrace{AKT_0W'} + \underbrace{AKT_eW'} = AK(T_0 + T_e)W' \quad \text{-----} (50)$$

Potencia de ruido de salida suponiendo un receptor ideal sin ruido

Potencia de ruido de salida debido al ruido generado en el receptor -- que tiene una temperatura de ruido equivalente T_e

De estas ecuaciones obtenemos la figura de ruido que está dada por:

$$NF = 1 + \frac{T_e}{T_0} \quad \text{-----} (51)$$

La temperatura de ruido T_e es equivalente a una temperatura hipotética, sin embargo es un parámetro muy conveniente y empleado muy frecuentemente. En la tabla (XV) se presenta la relación numérica entre un número de figuras de ruido y temperaturas de ruido equivalente.

Para bajas temperaturas de ruido (abajo de 100 K) tenemos la relación aproximada de:

$$T_e = 70 NF \text{ db} \quad \text{-----} (52)$$

706

704

T A B L A X V

VALORES NUMERICOS DE TEMPERATURA DE RUIDO EQUIVALENTE T_e
(K) Y FIGURA DE RUIDO CORRESPONDIENTE NF (db)₁

A temperatura ambiente (17°C) tenemos:

$$NF_{db} = 10 \log_{10} \left[1 + \frac{T(K)}{290} \right]$$

Temperatura de ruido T_e (K)	7	10	35	75	300	3000	30000
Figura de ruido NF (db)	0.100	0.148	0.496	1.002	3.092	10	20

NOTA:

$$T(^{\circ}K) = T(^{\circ}C) + 273 = (5/9) T(^{\circ}F) + 355$$

$$T(^{\circ}C) = 5/9 (T(^{\circ}F) - 32)$$

$$T(^{\circ}F) = 9/5 (T(^{\circ}C) + 32)$$

($^{\circ}C$) = CELSIUS

($^{\circ}K$) = KELVIN

($^{\circ}F$) = FAHRENHEIT

1 La figura de ruido NF es una razón de dos niveles de potencia. En el caso de amplificadores de bajo ruido (LNA), el ruido generalmente se expresa en grados KELVIN (K).

Las temperaturas típicas de ruido equivalente de receptores de satélite están en la gama de 1000 K ($NF = 7\text{db}$); hasta los receptores de estaciones terrenas que están en la gama de 20 a 1000 K.

12.1.9 DENSIDAD DE RUIDO, N_o . -- El término densidad de ruido nos presenta la potencia de ruido que está presente en un ancho de banda normalizado de 1Hz. Esto es:

$$N_o = \frac{N_{\text{TOTAL}}}{W} = K T_e \text{ ----- (53)}$$

Donde:

N_{TOTAL} - Potencia de ruido total medida en un sistema que tiene un ancho de banda de ruido W .

PARAMETROS EMPLEADOS FRECUENTEMENTE EN UN ENLACE

$$\frac{C}{N_o} \text{ - Razón de portadora a densidad de ruido. } \frac{C}{K T_e}$$

Considérese que la potencia promedio de la portadora de banda ancha es C y la densidad de ruido es N_o . C/N_o representa la razón de potencia de portadora de banda ancha promedio a la potencia de ruido, donde el ruido se mide en un ancho de banda normalizado de 1 Hz. Esta razón puede presentarse en términos de la temperatura de ruido equivalente como:

$$\frac{C}{N_o} = \frac{C}{K T_e} \text{ ----- (54)}$$

12.1.10 RAZON DE LA GANANCIA DE LA FIGURA DE MERITO A LA TEMPERATURA DE RUIDO EQUIVALENTE, G/T_e . -- La eficiencia de una sección receptora de una estación terrestre y la de un satélite se representan

~~708~~

ta frecuentemente en términos de la razón de la ganancia a la temperatura de ruido equivalente.

$$\text{Figura de Mérito} = \frac{G}{T_e} \text{ (db/K ó dbK}^{-1}\text{) } \text{-----} (55)$$

12.1.11 RAZON DE ENERGIA DEL BIT A LA DENSIDAD DE RUIDO $\frac{E_b}{N_o}$.--

Es uno de los parámetros mas frecuentemente empleados en sistemas de comunicación digital. Esta razón permite una comparación de sistemas que tienen velocidad de transmisión variables (baja y alta velocidad) y del funcionamiento de varios sistemas de modulación y codec en canales lineales y no lineales y en un medio ambiente de interferencia complejo.

La energía del bit, E_b , se obtiene multiplicando la potencia de la portadora C , por la duración del bit esto es,

$$E_b = C T_b \text{-----} (56)$$

donde. T_b - Tiempo de duración del bit.

13 ECUACIONES DE ENLACE.

Las ecuaciones que se derivan en esta sección son para un enlace de una sola portadora por transponder. Con relación a la fig. (18 a,b), la densidad de flujo a la entrada de la antena receptora de satélite esta dada por:

$$\Omega_u = \frac{P_T G_T}{4 R_u^2} L_u \text{ W/m}^2 \text{-----} (57)$$

La potencia de la portadora modulada que se recibe en el satélite está representada por:

$$P_u = \Omega_u A_{su} = \Omega_u \frac{G_{su} \lambda_u}{4\pi} \text{ Watts} \text{ ----- (58)}$$

El ruido del equipo y del canal, consiste del ruido intröducido por la lluvia, ruido de la tierra y el ruido térmico en el receptor. Para la mayoría de los sistemas prácticos este ruido tiene una densidad espectral de potencia plana sobre el ancho de banda del receptor de, N_{ou} W/Hz.

La razón de la potencia de portadora de enlace ascendente a la densidad de ruido está dada por:

$$\frac{C_u}{N_{ou}} = \frac{P_u}{N_{ou}} = \frac{P_u}{kT} \text{ ----- (59)}$$

Donde:

$$k = 1.30 \times 10^{-23} \frac{j}{k}$$

$$10 \log k = -228.6 \text{ dbw/K-Hz} = -198.6 \text{ dbm/K-Hz.}$$

T_e - Temperatura efectiva de ruido de entrada (K).

De las ecuaciones (57) a (59) obtenemos las ecuaciones básicas del enlace ascendente, que son:

$$\left(\frac{C_u}{N_{ou}} \right)_{db} = \underbrace{10 \log P_T G_T}_{\text{EIRP de la estación terrena.}} - \underbrace{20 \log \frac{4 R_u}{\lambda_u}}_{\text{Pérdida en el espacio libre ascendente.}} + \underbrace{10 \log \frac{G_{su}}{T_s}}_{\text{G/T del satélite}} + \underbrace{10 \log L_u}_{\text{Pérdidas adicionales ascendentes.}} - 10 \log k \text{ ----- (60)}$$

Sustituyendo de la ecuación (60) a $\frac{C}{T_e}$ por $\frac{kC}{N_o}$ obtenemos:

$$\frac{C_u}{T_{eu}} = 10 \log P_T G_T - 20 \log \frac{4 R_u}{\lambda_u} + 10 \log \frac{G_{su}}{T_s} + 10 \log L_u \text{ ---- (61)}$$

De la figura (18 b) el modelo para el enlace descendente empleando el mismo procedimiento, obtenemos las ecuaciones básicas para el descenso.

$$\frac{E_d}{N_{od}} \text{ db} = 10 \log (P_s G_{sd}) - 20 \log \frac{4 R_d}{d} + 20 \log \frac{G_d}{T_d} + 10 \log L_d -$$

EIRP del satélite Pérdidas en el espacio libre descendente G/T de la estación terrena Pérdidas adicionales descendentes

$$10 \log k \text{ ----- (62)}$$

y

$$\frac{C_d}{T_{ed}} \text{ db} = 10 \log (P_s G_{sd}) - 20 \log \frac{4 R_d}{d} + 20 \log \frac{G_d}{T_d} + 10 \log L_d \text{ ----- (63)}$$

En un sistema de satélites clásico con traslación de frecuencia, la razón de potencia de portadora total a la densidad de ruido en la estación terrena receptora es:

$$\frac{C}{N_o} T = \frac{1}{\frac{N_{ou}}{C_u} + \frac{N_{od}}{C_d}} \text{ ----- (64)}$$

Esta ecuación indica que el ruido ascendente y descendente se sumarán para formar el nivel de ruido total. Para sistemas de comunicaciones digitales la razón de energía del bit a la densidad de ruido $\frac{E_b}{N_o}$ del sistema total se obtiene considerando:

$$\left. \begin{aligned} E_{bu} &= C_u T_b \\ E_{bd} &= C_d T_b \end{aligned} \right\} \text{ ----- (65)}$$

de la ecuación (64) se observa que:

$$\left(\frac{E_b}{N_o}\right)_T = \frac{1}{\frac{N_{ou}}{E_{bu}} + \frac{N_{od}}{E_{bd}}} \text{-----(66)}$$

Obsérvese que en las ecuaciones (64) y (66) las cantidades son razones y no db.

La probabilidad de error del sistema digital estará en función de la razón de la energía total por bit a la densidad de ruido $\frac{E_b}{N_o}$ T.

14 CALCULO DEL ENLACE DE UN SISTEMA DE COMUNICACIONES DIGITAL VIA SATELITE.

La tabla (XVI) muestra los parámetros de un enlace vía satélite del sistema de comunicaciones de satélite Europeas (ECS) Los valores presentados, resultan al emplear las ecuaciones descritas hasta este punto.

TABLA XVI PARAMETROS DE UN ENLACE EN LA BANDA DE 14/11 GHz DEL SISTEMA DE COMUNICACIONES VIA SATELITE EUROPEOS ¹ (ECS)

ASCENDENTE	
1.- Potencia de salida del transmisor a saturación, 2 kw	33 dbw
2.- Pérdidas de combinación y del punto de operación	7 db
3.- Ganancia de la antena transmisora (15 m , 14 GHz)	64 db
4.- EIRP	90 dbw
5.- Pérdidas en el espacio libre (14 GHz)	207.5 db
6.- Pérdidas atmosféricas (14 GHz, tiempo despejado)	0.6 db
7.- G/T del satélite	- 5.3 db/K
8.- C a la entrada del repetidor	- 123.4 dbw/K
9.- Constante de Boltzman	- 228.6 $\frac{\text{dbw}}{\text{KHz}}$
10.- Velocidad de transmisión 120 Mb/s	80.8 dbHz
11.- Eb/No a la entrada del repetidor	24.4 db

1. Este sistema proporcionará una capacidad de 17000 circuitos telefónicos digitales bidireccionales en 1990. Los transponders individuales manejarán un tráfico de 120 Mb/s.

DESCENDENTE.

1.- EIRP del haz lateral (portadora no modulada, a saturación).	40.8 dbw
2.- Pérdidas del punto de operación de modulación y limitación en banda	0.6 db
3.- Pérdidas en el espacio libre (11.7 GHz)	205.6 db
4.- Pérdidas atmosféricas (11.7 GHz, tiempo despejado)	0.4 db
5.- Potencia en la antena receptora	- 165.8 dbw
6.- Ganancia de la antena receptora (15 m. , 11.7 GHz)	62.0 db
7.- Temperatura de ruido del sistema receptor (tiempo despejado) 270 K	24.3 dbk
8.- $\frac{G}{T}$ de la estación terrena	37.7 $\frac{db}{K}$
9.- $\frac{C}{T}$ a la entrada del receptor	- 128.1 $\frac{dbw}{K}$
10.- Constante de Boltzman	- 228.6 $\frac{dbw}{K Hz}$
11.- Velocidad de transmisión a 120 Mb/s	80.8 dbHz
12.- $\frac{E_b}{N_0}$ a la entrada del receptor	19.7 db

EIRP DE LA ESTACION TERRENA (EXPRESADA EN dbw ARRIBA DE 1w (dbw)).

La EIRP (dbw) = a la potencia de salida del transmisor (dbw) ganancia de la antena en db. Esto es igual a la potencia de salida del transmisor a saturación (dbw) - pérdidas del punto de operación y combinación (db) + Ganancia de la antena(db).

La ganancia de una antena de 15 m de diámetro a una frecuencia de 14 GHz es de 64 db. (ver fig. 20). Las pérdidas por punto de operación y combinación son de 7 db y la potencia de salida del transmisor es para este caso de 33 dbw por lo que:

$$EIRP (dbw) = 33 dbw - 7 db + 64 db = 90 dbw$$

La pérdida en el espacio libre ascendente a 14 GHz es de 207.5 db (ver fig. 21).

$\frac{C}{T}$ DEL ENLACE ASCENDENTE.

Sustituyendo la pérdida en el espacio libre por trayectoria, la EIRP, la $\frac{G}{T}$ del satélite y las pérdidas atmosféricas que son para este caso de 0.6 db en las ecuaciones (62) y (63), se

obtiene:

$$\frac{C_u}{T_{eu}} = 90 \text{ dbw} - 207.5 \text{ db} + (-5.3) \frac{\text{db}}{\text{K}} + (-0.6) \text{ db} = -123.4 \frac{\text{dbw}}{\text{K}}$$

Para el cálculo del $\frac{E_b}{N_o}$ disponible a la entrada del transponder del satélite, primero se calcula $\frac{C_u}{N_{ou}}$, o sea:

$$\begin{aligned} \frac{C_u}{N_{ou}} \text{ db} &= 90 \text{ dbw} - 207.5 \text{ db} - 5.3 \frac{\text{db}}{\text{K}} - 0.6 \text{ db} + 228.6 \text{ dbw} = 105.2 \frac{\text{dbw}}{\text{Hz}} \\ &= 135.2 \frac{\text{dbw}}{\text{Hz}} \end{aligned}$$

La energía del bit ascendente para el sistema de 120 Mb/s es:

$$E_{bu} = C_u T_b$$

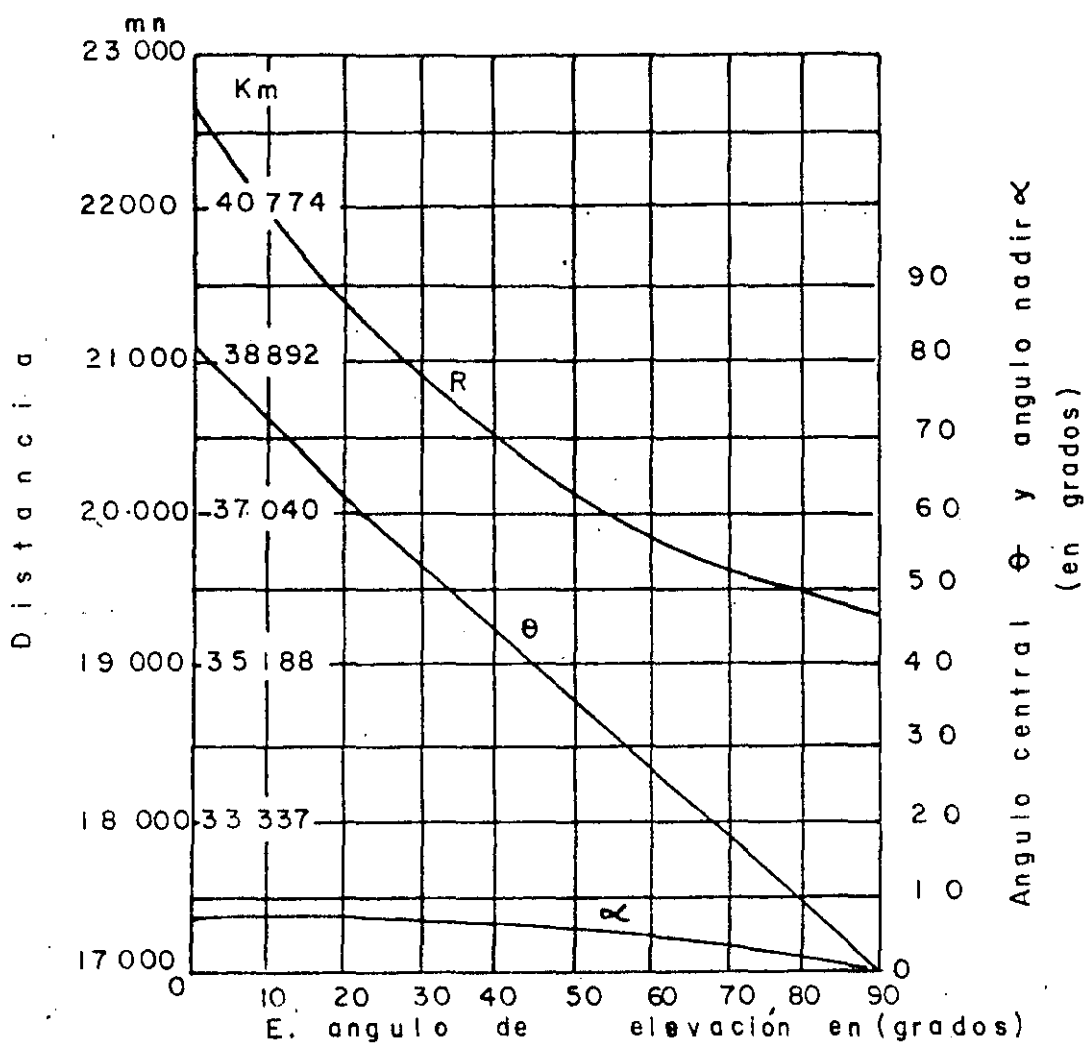
$$\begin{aligned} E_{bu} \text{ dbm} &= C_u(\text{dbw}) + 10 \log T_b (\text{seg}) \\ &= 105.2 \frac{\text{dbw}}{\text{Hz}} + 10 \log \frac{1}{120 \times 10^6} \text{ seg} \\ &= 105.2 - 80.8 \text{ dbs} \\ &= 24.4 \text{ dbs} \end{aligned}$$

$$\begin{aligned} \frac{E_{bu}}{N_o} &= \frac{C_u}{N_o} T_b \\ &= 105.2 \frac{\text{dbw}}{\text{Hz}} + 10 \log \frac{1}{120 \times 10^6} \text{ seg} \\ &= 105.2 - 80.8 \\ &= 24.4 \text{ dbs.} \end{aligned}$$

Para calcular las razones en la trayectoria descendente se sigue un procedimiento análogo al anterior.

714

712



a)

EJEMPLOS DE DISEÑOS DE ENLACES

EJEMPLOS ILUSTRATIVOS PARA EL DISEÑO DE ENLACES
VIA SATELITE PARA DIFERENTES TIPOS DE SERVICIO.

Todos los diseños aquí mostrados fueron hechos utilizando los parámetros del "Sistema Morelos de Satélites".

Estos diseños fueron hechos para tres tipos de servicios básicos que son:

- 1) Televisión
- 2) Telefonía multicanal FDM/FM
- 3) Telefonía SCPC

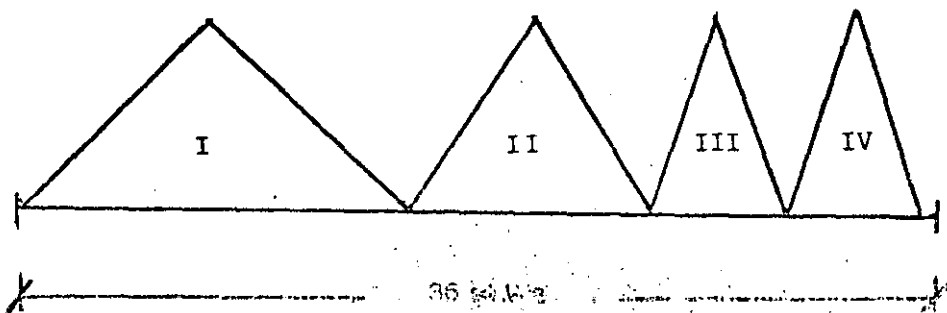
Con las siguientes modalidades:

1) Televisión

- a) Utilizando un transpondedor de 36 MHz con 1 portadora de T.V. + audio asociado en banda C.
- b) Utilizando un transpondedor de 72 MHz con 2 portadoras de T.V. + audio asociado en banda C.
- c) Utilizando un transpondedor de 108 MHz con 2 portadoras de T.V. + audio asociado en banda Ku.

2) Telefonía multicanal FDM/FM

- a) Utilizando un transpondedor de 36 MHz de la siguiente manera.



- I.- Cursando 312 canales FDM/FM ocupando 15 MHz.
- II.- Cursando 132 canales FDM/FM ocupando 10 MHz.
- III.- Cursando 60 canales FDM/FM ocupando 5 MHz.
- IV.- Cursando 72 canales FDM/FM ocupando 5 MHz.

Sólo se presenta la metodología de cálculo para el primer caso (312 canales) ya que para los demás casos es la misma, mostrándose al final una tabla de resultados para las diferentes cargas telefónicas.

3) Telefonía S.C.P.C.

- a) Analógica en un transpondedor de 36 MHz
- b) Digital en un transpondedor de 36 MHz.

EJEMPLOS DE DISEÑO PARA TELEVISION

CASO a:

DATOSEnlace:

Transmisión: México

Receptora: Tijuana

Posición Geográfica:

Latitud	19.35° N	32.5° N
Longitud	99.01° W	117.03° W
ASNM	2.233 Km.	0.016 Km.

Datos estaciones terrenas:

	Diámetros de Ant.	Ganancia	Figura de Mérito
Transmisora	11 mts.	54.5 dbi	-
Receptora	5 mts.	-	23.73 dB/oK

Datos del satélite para esos dos puntos de enlace:

PIRE del satélite en saturación	36.2 dB
Densidad de flujo para saturar el satélite	-82 dBw/m ²
Figura de mérito del satélite	3.9 dB/°K
Atenuador de posición	0 dB
Back-off de entrada al satélite	0 dB
Back-off de salida del satélite	0 dB

Frecuencia de operación y margen de lluvia.

Frecuencia de operación de la portadora ascendente	6.405 GHz
Frecuencia de operación de la portadora descendente	3.74 GHz
Margen de lluvia ascendente y descendente	1.5 dB

Parámetros de la señal de video

Modulación	F.M.
Norma de televisión utilizada	525/60 Líneas/campos
Desviación pico de la frecuencia de video	10.75 MHz
Frecuencia máxima de banda base de video	4.2 MHz
Factor de mejoramiento (Enfasis, ponderación)	1.574

Parámetros de la señal de audio *

Frecuencia máxima de audio	15 KHz
Frecuencia de la subportadora	6.8 MHz
Ancho de banda de ruido del audio	15 KHz
Ancho de banda del ruido del filtro de la subportadora	600 KHz
Desviación pico de la portadora debido a la subportadora	2 MHz
Desviación pico de la subportadora	75 KHz
Mejoramiento por pre/deenfasis	12 dB

* Datos utilizados por la compañía Scientific Atlanta.

MEMORIA DE CALCULO

Cálculo de las distancias de las estaciones terrenas (transmisora y receptora) al satélite Morelos I ubicado en - - 113.5° W longitud oeste.

Las fórmulas utilizadas para este cálculo vienen detalladas en el capítulo de estaciones terrenas de éstos apuntes.

Ecuaciones utilizadas en el cálculo

$$\underline{\Delta \phi = \phi_e - \phi_s}$$

Donde:

$\Delta \phi$ = Diferencia de longitudes

ϕ_e = Longitud de la estación terrena

ϕ_s = Longitud del satélite

$$\underline{\cos \beta = \cos \gamma \cos \Delta \phi}$$

Donde:

γ = Latitud de la estación terrena

$$l = \left[(R+ASN)^2 + (R+H)^2 - (R+ASN)(R+H)\cos \beta \right]^{1/2}$$

Donde:

l = Distancia de la estación terrena al satélite

R = Radio medio de la Tierra = 6378 Km

ASNM = Altura sobre el nivel del mar de la estación terrena

H = Altura del Satélite en forma perpendicular sobre el ecuador

\approx 35786 Km.

Sustituyendo valores en las ecuaciones antes mencionadas para la estación terrena transmisora. (México)

$$\Delta\phi = 99.01 - 113.5 = -14.99^\circ$$

$$\cos \Delta\phi = 0.96819$$

$$\gamma = 19.35^\circ \quad \cos \gamma = 0.9435$$

$$\cos \beta = (0.94351)(0.96819)$$

$$\cos \beta = 0.9134 \quad \beta = 24.02^\circ$$

$$l = \left[(6378+2.233)^2 + (6378+35786)^2 - 2(6378+2.233)(6378+35786)0.9134 \right]^{1/2}$$

$l_1 = 36428.994$ Km Distancia que hay entre México y el satélite Morelos I

Sustituyendo valores en las mismas ecuaciones para los valores de la estación terrena receptora (Tijuana)

$$\Delta\theta = 117.03 - 113.5 = 3.53^\circ$$

$$\cos \Delta\theta = 0.9950$$

$$\cos \beta = [\cos 32.5^\circ] [\cos 3.533^\circ]$$

$$\cos \beta = 0.84170 \quad \beta = 32.67^\circ$$

$$l_2 = \left[(6378+0.016)^2 + (6378+35786)^2 - 2(6378+0.016)(6378+35786)0.84176 \right]^{1/2}$$

$l_2 = 36956.428$ Km Distancia que hay entre Tijuana y el satélite Morelos I.

Cálculo del $\left[\frac{C}{N_0} \right]_T$ del enlace

Cálculo del $\left[\frac{C}{N_0} \right]_U$ (ascendente)

De la ecuación (14) de las notas tenemos:

$$\left[\frac{C}{N_0} \right]_U = W_s - 10 \log \frac{4\pi}{\lambda^2} + \left[\frac{G}{T} \right]_s - 10 \log K - BO_i$$

Simplificando el término: $-10 \log \frac{4\pi}{\lambda^2}$ queda:

$$\text{Sabemos que: } \lambda = \frac{c}{f} : \therefore -10 \log \frac{4\pi f^2}{c^2}$$

si expresamos:

$$c = 3 \times 10^8 \text{ m/seg y en } f \text{ en GHz:}$$

$$-10 \log \frac{4\pi f^2}{c^2} = -10 \log \frac{4\pi f^2 \times 10^{18}}{9 \times 10^{16}} = -10 \log \left[\frac{4\pi \times 10^{-18}}{9 \times 10^{16}} + 2 \log f(\text{GHz}) \right]$$

$$-10 \log \frac{4\pi f^2}{c^2} = -21.45 - 20 \log f(\text{GHz}).$$

sustituyendo este valor en la ecuación (14):

$$\left[\frac{C}{N_0} \right]_U = W_s - 20 \log f(\text{GHz}) - 21.45 + \left[\frac{G}{T} \right]_s - 10 \log K - BO_i \text{ (dB-Hz) } - (I)$$

La ecuación (I) es la que se utilizará para cálculos posteriores.

Sustituyendo los datos antes tabulados para este enlace en la ecuación (1).

$$\left[\frac{C}{N_0} \right]_u = -82 - 20 \log 6.405 - 21.45 + 3.9 + 228.6 - 0$$

En donde:

$$- 10 \log K = -10 \log(1.38038 \times 10^{-23}) = 228.6$$

$$\left[\frac{C}{N_0} \right]_u = 112.919 \text{ dB} - \text{Hz}$$

Cálculo del $\left[\frac{C}{N_0} \right]_D$ (descendente).

De la ecuación (16) de los apuntes tenemos:

$$\left[\frac{C}{N_0} \right]_D = P_{SM} - [B_0]_o - L_d + \left[\frac{G}{T} \right]_E - 10 \log K$$

Haremos uso de la ecuación antes mencionada sólo que la $\left[\frac{C}{N_0} \right]_D$ la afectaremos por el margen de lluvia -- descendente debido a que la potencia que nos entrega el satélite es fija, de tal manera que al llover nuestro enlace descendente sería afectado por la atenuación y ruido producido por la lluvia, para compensar esto agregaremos un término a la ecuación (16) que llamaremos margen de lluvia descendente M_D , quedando la ecuación (16) expresado como sigue:

$$\left[\frac{C}{N_0} \right]_D = P_{SM} - [B_0]_o - L_d + \left[\frac{G}{T} \right]_E - 10 \log K - M_D$$

Recordando que: $-10 \log K = 228.6$ ∴.

$$\left[\frac{C}{N_0} \right]_D = P_{SM} - B_{O_0} - L_d + \left[\frac{G}{T} \right]_E + 228.6 - M_D \text{ (dB-Hz)} \text{ ---- (II)}$$

En donde L_d puede ser calculado mediante la siguiente ecuación

$$L_d = 92.45 + 20 \log f(\text{GHz}) + 20 \log \lambda_2 \text{ (Km)} \text{ (dB)} \text{ --- (III)}$$

en donde:

$f(\text{GHz})$: es la frecuencia de operación del enlace en expresado en Gigahertz

λ_2 (Km): es la distancia que hay entre el satélite y la estación terrena receptora expresada en kilómetros

La ecuación (II) y (III) son las que se utilizaron para todos los cálculos posteriores.

Sustituyendo los datos antes tabulados para este enlace, la distancia que hay entre el satélite y la estación terrena receptora Tijuana (ya antes calculada), en las ecuaciones (II) y (III).

$$L_d = 92.45 + 20 \log (3.74) + 20 \log (36956.428)$$

$$L_d = 195.2612 \text{ dB}$$

$$\left[\frac{C}{N_0} \right]_D = 36.2 - 0 - 195.2612 + 23.73 + 228.6 - 1.5$$

$$\left[\frac{C}{N_0} \right]_D = 91.76 \text{ dB-Hz}$$

Ruido de intermodulación

El valor del ruido de intermodulación es considerado cero ya que estamos trabajando el TWT del satélite con una sola portadora por lo tanto:

$$\left[\frac{C}{No} \right]_{IM} = 0$$

Cálculo de la $\left[\frac{C}{No} \right]_T$ Relación portadora a densidad de ruido total .

El cálculo de la $\left[\frac{C}{No} \right]_T$ puede encontrarse mediante la siguiente ecuación:

$$\left[\frac{C}{No} \right]_T = 10 \log \left[\frac{1}{\frac{1}{\text{Antilog} \left(\frac{C}{No} \right)_u / 10} + \frac{1}{\text{Antilog} \left(\frac{C}{No} \right)_D / 10} + \frac{1}{\text{Antilog} \left(\frac{C}{No} \right)_{IM} / 10}} \right] \quad (\text{dB-Hz}) \text{---(IV)}$$

Aplicando la ecuación (d):

$$\left[\frac{C}{No} \right]_T = 10 \log \left[\frac{1}{\frac{1}{\text{Antilog } 11.291} + \frac{1}{\text{Antilog } 9.176} + 0} \right]$$

$$\left[\frac{C}{No} \right]_T = 91.72 \text{ dB-Hz}$$

Cálculo de la $\left[\frac{C}{N} \right]_T$ (relación portadora a ruido total)

$$\left[\frac{C}{N} \right]_T = \left[\frac{C}{N_0} \right]_T - 10 \log \left[B_{IF} \right] \text{--- (V)}$$

donde:

$\left[B_{IF} \right]$ = Ancho banda de ruido de frecuencia de intermedia del equipo receptor

Sustituyendo valores:

$$\left[\frac{C}{N} \right]_T = 91.72 - 10 \log (36 \times 10^6)$$

$$\left[\frac{C}{N} \right]_T = 16.16 \text{ dB}$$

Cálculo de la relación señal a ruido de video $\left[\frac{S}{N} \right]_V$

El cálculo de $\left[\frac{S}{N} \right]_V^*$ se hará mediante la siguiente ecuación:

$$\left[\frac{S}{N} \right]_V = \left[\frac{C}{N_0} \right]_{T(\text{dB-MHz})} + 10 \log \left[\frac{12(0.714 \times \Delta f_v)^2}{b_s^3} \right] \text{---(VI)}$$

Donde:

$\left[\frac{C}{N_0} \right]_{T(\text{dB-MHz})}$ = Relación portadora a densidad de ruido total expresada en dB-MHz.

Δf_v = Densidad pico de la frecuencia video = 10.75 MHz.

b_s = Factor de mejoramiento (combinación de ponderación y énfasis).
= 1.574 Norma CCIR

* Nota.- Ver artículo que se anexa al final.

$$\left[\frac{S}{N} \right]_v = \left[\frac{C}{N_o} \right]_T \text{ dB-MHz} + 10 \log \left[\frac{12(0.714 \times 10.75)}{(1.574)^3} \right]$$

$$\left[\frac{S}{N} \right]_v = \left[\frac{C}{N_o} \right]_{T \text{ dB-MHz}} + 22.58 \text{ --- (VII).}$$

El valor de 22.58 es el standar utilizado por los sistemas de E.U., Canadá y es el que utilizaremos, por lo cual la ecuación (VII) antes escrita es la que va a ser usada para cálculos posteriores de éstos ejemplos:

Sustituyendo valores en (VII)

$$\left[\frac{C}{N_o} \right]_{T \text{ dB-MHz}} = \left[\frac{C}{N} \right]_T + 10 \log \left[B_{IF} \right]$$

$$\left[\frac{C}{N_o} \right]_T \text{ dB-MHz} = 16.16 + 10 \log (36) = 31.72 \text{ dB-MHz}$$

$$\left[\frac{C}{N_o} \right]_T = 31.72 \text{ dB - MHz : .}$$

$$\left[\frac{S}{N} \right]_v = 31.72 + 22.58$$

$$\left[\frac{S}{N} \right]_v = 54.30 \text{ dB}$$

Cálculo de la $\left[\frac{S}{N} \right]_A$ de audio

El cálculo de $\left[\frac{S}{N} \right]_A$ se hará mediante las siguientes ecuaciones:

[S/N] [S/N] [S/N]

Donde:

$[C/N]_{SC}$ = Relación portadora a ruido de la subportadora

$[C/N]$ = Relación portadora a ruido del enlace

B_{IF} = Ancho de banda de ruido de frecuencia intermedia

B_{SC} = Ancho de banda de ruido del filtro de la subportadora

ΔF_c = Desviación pico de la portadora debido a la subportadora

F_{SC} = frecuencia de la subportadora

$$[S/N]_A = [C/N]_{SC} + 10 \log 3 \left[\frac{\Delta f_{sc}}{f_m} \right]^2 + 10 \log \left[\frac{B_{sc}}{2B_a} \right] + E \text{ --- (IX)}$$

f_m = Frecuencia de audio máxima

B_a = Ancho de banda de ruido del audio

Δf_{sc} = Desviación pico de la subportadora

E = Ventaja del audio por pre/deenfasis

Sustituyendo valores antes tabulados en la ecuación de

$$[C/N]_{sc} \text{ y } [S/N]_A :$$

$$\left[\frac{C}{N} \right]_{sc} = 16.16 + 10 \log \left[\frac{36 \times 10^6}{2(600 \times 10^3)} \right] + 10 \log \left[\frac{2 \times 10^6}{6.8 \times 10^6} \right]^2$$

$$\left[\frac{C}{N} \right]_{sc} = 16.16 + 4.14$$

$$\left[\frac{C}{N} \right]_{sc} = 20.3 \text{ dB}$$

$$\left[\frac{S}{N} \right]_A = 20.3 + 10 \log 3 \left[\frac{75 \times 10^3}{15 \times 10^3} \right]^2 + 10 \log \left[\frac{600 \times 10^3}{(2)(15 \times 10^3)} \right] + 12$$

$$\left[\frac{S}{N} \right]_A = 20.3 + 43.76$$

$$\left[\frac{S}{N} \right]_A = 64.06 \text{ dB}$$

Cálculo de la potencia de salida del HPA de la estación
terrena transmisora.

a) Primero se calcula el $\text{PIRE}]_{ET}$ entregado por la estación terrena en función de la densidad de flujo requerida en el satélite:

$$\text{PIRE}]_{ET} = W_s + 10 \log 4\pi l_1^2 + M_A - BO_i \text{ (dBw) --- (X)}$$

donde:

W_s = Densidad de flujo

l_1 = Distancia al satélite en metros de la estación

130

M_A = Margen de lluvia ascendente para
compensar la atenuación

BO_i = Back-off entrada al satélite

b) Segundo se procede al cálculo del HPA:

$$HPA = PIRE \left. \vphantom{HPA} \right]_{ET} - G_{ANT} + L_{ET} + BO_{HPA} \quad (\text{dBw}) \quad \text{---(XI)}$$

donde

G_{ANT} = Ganancia de la antena en transmisión

L_{ET} = Pérdidas que sufre la señal hasta antes de ser radiada por la antena (guías de onda, conectores, etc.)

BO_{HPA} = Back-off de salida del HPA

El HPA en watts se calcula:

$$HPA = \text{antilog} \frac{HPA}{10} \quad (\text{watts}) \quad \text{--- (XII)}$$

Sustituyendo los datos de éste ejemplo en las ecuaciones anteriores:

$$PIRE_{ET} = -82 + 10 \log 4 \pi (36428.994 \times 10^3)^2 + 1.5$$

$$PIRE_{ET} = 81.72 \text{ dBw}$$

$$HPA = 81.72 - 54.50 + 3 + 0 = 30.22 \text{ dBw}$$

$$HPA(\text{watts}) = \text{Antilog} \frac{30.22}{10}$$

EJEMPLOS DE DISEÑO

PARA TELEVISION

CASO: b

Este caso se refiere a un programa de televisión que se emite los días martes y viernes a las 8 de la noche. El programa trata sobre la vida cotidiana de una familia que vive en un pueblo pequeño. El programa es muy popular y atrae a un gran número de espectadores. El diseño del programa es muy atractivo y fácil de entender. El programa es muy educativo y ayuda a los niños a aprender sobre la vida cotidiana. El programa es muy divertido y ayuda a los niños a pasar un buen rato. El programa es muy interesante y ayuda a los niños a aprender sobre el mundo que los rodea. El programa es muy útil y ayuda a los niños a mejorar sus habilidades de comunicación. El programa es muy bueno y ayuda a los niños a crecer y desarrollarse.

Cálculo de $\left[\frac{S}{N} \right]_V$:

$$\left[\frac{S}{N} \right]_V = 26.83 + 22.58$$

$$\left[\frac{S}{N} \right]_V = 49.41 \text{ dB}$$

Cálculo de $\left[\frac{S}{N} \right]_A$

$$\left[\frac{C}{N} \right]_{SC} = 11.27 + 4.14$$

$$\left[\frac{C}{N} \right]_{SC} = 15.41 \text{ dB}$$

$$\left[\frac{S}{N} \right]_A = 15.41 + 43.76$$

$$\left[\frac{S}{N} \right]_A = 59.17 \text{ dB}$$

Cálculo del HPA

$$\text{PIRE} \left. \right]_{ET} = W_s + 10 \log 4\pi l^2 + M_A - BO_i$$

$$\text{PIRE} \left. \right]_{ET} = 82 + 10 \log 4 \cdot (36428.994 \times 10^3)^2 + 1.5 - 8$$

$$\text{PIRE} \left. \right]_{ET} = 73.72 \text{ dBw}$$

$$\text{HPA} = 73.72 - 54.50 + 3 + 0 = 22.22 \text{ dBw}$$

$$\text{HPA} = 166.76 \text{ watts}$$

EJEMPLOS DE DISEÑO

PARA TELEVISION

CASO: c

DATOSEnlace:

Transmisión: México

Receptora: Cd. Victoria

Zona Geográfica Centro

Zona Geográfica: Golfo Norte

Posición Geográfica:

Latitud	19.35°N	23.73° N
Longitud	99.01°W	99.14° W
ASN	2.233 Km	0.321 Km

Datos estaciones terrenas:

	Dímetros de Ant.	Ganancia	Figura de Mérito
Transmisora	7.6 mts.	59.50 dbi	--
Receptora	7.6 mts.	--	34.16 dB/°K

Datos del satélite para esos dos puntos de enlace:

PIRE del satélite en saturación	44.50 dB
Densidad de flujo para saturar el satélite	-81.50 dBw/m ²
Figura de Mérito del satélite	2 dB/°K
Atenuador de posición	0 dB
Back-off de entrada al satélite	8 dB
Back-off de salida del satélite	4.5 dB

Frecuencias de operación y márgenes de lluvia.

Frecuencia de operación de la portadora ascendente	14.463 GHz
Frecuencia de operación de la portadora descendente	12.163 GHz
Márgen de lluvia ascendente	8.3 dB

Porcentaje de confiabilidad ascendente	99.98 %
Márgen de lluvia descendente	7.6 dB
Porcentaje de confiabilidad descendente	99.80 %

Los parámetros de la señal de video y audio, son los mismos que se utilizaron en el primer ejemplo.

Cálculo de las distancias de las estaciones terrenas (transmisora y receptora) involucradas en el enlace, al satélite Morelos I ubicado en 113.5°W longitud oeste.

En el caso de México, la distancia ya fue calculada en el ejemplo del caso a)

$$l_1 = 36428.994 \text{ Km. distancia que hay entre México y el --} \\ \text{satélite Morelos I}$$

Sustituyendo datos para Cd. Victoria:

$$\Delta\theta = 99.14 - 113.5 = -14.36$$

$$\cos \Delta\theta = 0.9687$$

$$\gamma = 23.73^\circ \quad \cos \gamma = 0.91545$$

$$\cos \beta = (0.9687) (0.91545)$$

$$\cos \beta = 0.88679$$

$$l_2 = \left[(6378+0.321)^2 + (6378+35786)^2 - 2 (6378+0.321) (6378+35786) 0.88679 \right]^{1/2}$$

$$l_2 = 36626.591 \text{ Km. Distancia que hay entre Cd. Victoria y el} \\ \text{satélite Morelos I}$$

Cálculo del $[C/No]_T$ del enlace

741

Cálculo del $[C/No]_U$ (ascendente)

$$[C/No]_U = W_s - 20 \log f(\text{GHz}) - 21.45 + [G/T]_S + 228.6 - B01$$

Como estamos utilizando el transpondedor a la mitad de su capacidad para una señal de video+audio asociado por lo cual:

$$W_{s/2} = W_s - 3 \text{ dB}$$

$$W_{s/2} = -81.5 - 3 = -84.5 \text{ dBw/m}^2$$

Sustituyendo este valor en W_s de la ecuación ascendente y los demás parámetros que son datos:

$$[C/No]_U = -84.5 - 20 \log 14.463 - 21.45 + 2 + 228.6 - 8$$

$$[C/No]_U = 93.44 \text{ dB - Hz}$$

Cálculo del $[C/No]_D$ (descendente)

742

$$[C/No]_D = P_{SM} - BO_o - Ld + [G/T]_E + 228.6 - M_D$$

Como se utiliza la mitad del transpondedor del satélite el PIRE que entrega será reducido en 3 dB.

Sustituyendo los datos en las ecuaciones:

$$Ld = 92.45 + 20 \log (12.163) + 20 \log (36626.591)$$

$$Ld = 205.42 \text{ dB}$$

$$[C/No]_D = (44.5 - 3) - 4.5 - 205.42 + 34.16 + 228.6 - 7.6$$

$$[C/No]_D = 86.74 \text{ dB - Hz}$$

Cálculo del $[C/No]_{IM}$

Al igual que el ejemplo anterior si asumimos un valor de - -

$$[C/N]_I = 21 \text{ dB de la gráfica 1}$$

$$[C/No]_{IM} = [C/N]_I + 10 \log B_{IF}$$

Sustituyendo valores queda:

$$[C/No]_{IM} = 21 + 10 \log 36 \times 10^6$$

$$\left[\frac{C}{N_0} \right]_{IM} = 96.56 \text{ dB} - \text{Hz}$$

Cálculo del $\left[\frac{C}{N_0} \right]_T$

$$\left[\frac{C}{N_0} \right]_T = 10 \log \left[\frac{1}{\frac{1}{\text{Antilog } 9.344} + \frac{1}{\text{Antilog } 8.674} + \frac{1}{\text{Antilog } 9.656}} \right]$$

$$\left[\frac{C}{N_0} \right]_T = 85.54 \text{ dB} - \text{Hz}$$

Cálculo del $\left[\frac{C}{N} \right]_T$

$$\left[\frac{C}{N} \right]_T = 85.54 - 10 \log 36 \times 10^6$$

$$\left[\frac{C}{N} \right]_T = 9.97 \text{ dB}$$

Expresado en dB-MHz

$$\left[\frac{C}{N} \right]_T \text{ dB-MHz} = 25.54 \text{ dB} - \text{MHz}$$

Cálculo del $\left[\frac{S}{N} \right]_V$:

$$\left[\frac{S}{N} \right]_V = 25.54 + 22.58$$

$$\left[\frac{S}{N} \right]_V = 48.12 \text{ dB}$$

El cálculo de las distancias de estaciones terrenas (transmisora y receptora) al satélite Morelos I es igual que el ejemplo de caso a) para televisión.

$l_1 = 36428.99$ Km. Distancia de México al satélite

$l_2 = 36955.845$ Km. Distancia de Tijuana al satélite

Cálculo del $[C/No]_T$ del enlace

Cálculo del $[C/No]_U$ (ascendente).

$$[C/No]_U = W_s - 20 \log f(\text{GHz}) - 21.45 + [G/T]_S + 228.6 - B01$$

En este caso como estamos ocupando solo 15 MHz del ancho de banda del transpondedor (ancho banda asignado en el satélite, dato) de los 36 MHz disponibles, por lo tanto cantidad de potencia que se ocupe del satélite, será proporcional al ancho de banda ocupado por la señal y la densidad de flujo requerida también es proporcional al ancho de banda ocupado por la señal. Para calcular el PIRE del satélite entregado y la densidad de flujo requerida para el ancho banda asignado en el satélite procederemos de la siguiente forma:

$$\% BW_0 = \frac{(15\text{MHz})(100)}{36 \text{ MHz}} = 41.66 \%$$

Densidad de flujo requerida y PIRE del satélite para este ancho de banda:

$$W_{sp} = \left(\text{antilog} \frac{-82.00}{10} \right) (0.4166) = 2.6285683 \times 10^{-9} \frac{\text{watt}}{\text{m}^2}$$

$$P_{sm} = \left(\text{antilog} \frac{36.20}{10} \right) (0.4166) = 1736.6779 \text{ watts}$$

Expresado en dB queda:

$$W_{sp} = -85.802 \text{ dBw/m}^2 \text{ Densidad de flujo para portadora de interés}$$

$$P_{sm} = 32.397 \text{ dBw PIRE para portadora de interés}$$

Sustituyendo en la ecuación del enlace ascendente:

$$\left[\frac{C}{No} \right]_U = -85.802 - 20 \log 6.405 - 21.45 + 3.9 + 228.6 - 10$$

$$\left[\frac{C}{No} \right]_U = 99.117 \text{ dB} - \text{Hz}$$

Cálculo de $\left[\frac{C}{No} \right]_D$ (descendente)

$$\left[\frac{C}{No} \right]_D = P_{sm} - B0. - Ld + \left[\frac{G}{T} \right]_E + 228.6 - MD$$

Sustituyendo valores:

$$Ld = 92.45 + 20 \log 4.18 + 20 \log (36955.845)$$

$$Ld = 196.227 \text{ dB}$$

$$\left[\frac{C}{No} \right]_D = 32.397 - 5.3 - 196.227 + 31.7 + 228.6 - 1.5$$

$$\left[\frac{C}{No} \right]_D = 89.67 \text{ dB} - \text{Hz}$$

750

Cálculo del $\left[\frac{C}{No} \right]_{IM}$

A partir de la figura 1 para cuatro portadoras y un back-off de salida de 5.3 dB se tiene un valor aproximado de $\left[\frac{C}{N} \right]_I$ de 19.7 dB entonces:

$$\left[\frac{C}{No} \right]_{IM} = \left[\frac{C}{N} \right]_I + B_{IF}$$

Sustituyendo valores:

$$\left[\frac{C}{No} \right]_{IM} = 19.7 + 10 \log 13.5 \times 10^6$$

$$\left[\frac{C}{No} \right]_{IM} = 90.90 \text{ dB} - \text{Hz}$$

Cálculo del $\left[\frac{C}{No} \right]_T$

$$\left[\frac{C}{No} \right]_T = 10 \log \left[\frac{1}{\frac{1}{\text{Antilog } 9.911} + \frac{1}{\text{Antilog } 8.967} + \frac{1}{\text{Antilog } 9.09}} \right]$$

$$\left[\frac{C}{No} \right]_T = 86.95 \text{ dB} - \text{Hz}$$

Cálculo de $\left[\frac{C}{N} \right]_T$

$$\left[\frac{C}{N} \right]_T = \left[\frac{C}{No} \right]_T - 10 \log B_{IF}$$

$$\left[\frac{C}{N} \right]_T = 86.95 - 10 \log 13.5 \times 10^6$$

$$\left[\frac{C}{N} \right]_T = 15.64 \text{ dB}$$

Cálculo de $\left[\frac{S}{N} \right]$ para telefonía multicanal.

La relación $\left[\frac{S}{N} \right]$ puede obtenerse mediante la siguiente ecuación

$$\left[\frac{S}{N} \right] = \left[\frac{C}{N} \right]_T + 20 \log \left[\frac{Af_{TT}}{f_{ch}} \right] + 10 \log \left[\frac{B_{IF}}{B_{ch}} \right] + P + W \text{ ---(XIV)}$$

Donde:

Af_{TT} = Desviación (rms) de tono de prueba

f_{ch} = Frecuencia de banda base más alta

B_{IF} = Ancho de banda ruido de frecuencia intermedia

B_{ch} = Ancho de banda del canal telefónico (usualmente
3.1 KHz)

P = Factor de mejoramiento por preenfasis (4.0 dB)

W = Factor de mejoramiento por ponderación (2.5dB)

Sustituyendo en la ecuación anterior los valores antes tabulados y el $\left[\frac{C}{N} \right]_T$ tenemos:

$$\left[\frac{S}{N} \right] = 15.64 + 20 \log \left[\frac{546 \times 10^3}{1300 \times 10^3} \right] + 10 \log \left[\frac{13.5 \times 10^6}{3.1 \times 10^3} \right] + 4.0 + 2.5$$

$$\left[\frac{S}{N} \right] = 50.99 \text{ dB}$$

Cálculo de la potencia de ruido:

Mediante la ecuación (12) tenemos que:

$$10 \log N = 83.5 - \left[\frac{C}{N_0} \right]_T + 10 \log B_{ch} - 20 \log \left[\frac{A_{fTT}}{f_{ch}} \right]$$

Sustituyendo valores en la ecuación anterior

$$10 \log N = 83.5 - 86.95 + 10 \log (3.1 \times 10^3) - 20 \log \frac{546 \times 10^3}{1300 \times 10^3}$$

$$10 \log N = 38.998$$

$$N = \text{antilog} \frac{38.998}{10}$$

$$N = 7940.77 \text{ pWop}$$

Otra forma de calcularlo es mediante la siguiente ecuación

$$N = \text{Antilog} \frac{90 - \left(\frac{S}{N} \right)}{10} \text{ pWop} \text{ --- (XV)}$$

$$N = \text{Antilog} \frac{90 - 50.99}{10}$$

$$N = 7961.59 \text{ pWop.}$$

Cálculo del HPA

$$\text{PIRE}]_{\text{ET}} = W_s + 10 \log 4\pi \lambda_1^2 + M_A - \text{BOI}$$

$$\text{PIRE}]_{\text{ET}} = -85.802 + 10 \log 4\pi (36428.99 \times 10^3)^2 + 1.5 - 10$$

$$\text{PIRE}]_{\text{ET}} = 67.919 \text{ dBw}$$

$$\text{HPA} = \text{PIRE}]_{\text{ET}} - G_{\text{ANT}} + L_{\text{ET}} + \text{BO}_{\text{HPA}}$$

$$\text{HPA} = 67.919 - 54.5 + 3 + 3$$

$$\text{HPA} = 19.419 \text{ dBw}$$

$$\text{HPA} = 87.47 \text{ watts}$$

TABLA DE RESULTADOS PARA LAS DIFERENTES CARGAS TELEFONICAS

Place	NCT	∅Ant. Tx	∅Ant. Rx.	BOi	BOo	$[C/N]_U$	$[C/N]_D$	$[C/No]_{IM}$	$[C/No]_T$	$[S/N]$	N	HPA
		m	m	dB	dB	dB-Hz	dB-Hz	dB-Hz	dB-Hz	dB	pWop	watts
Mexico-Tijuana	312	11	11	10	5.3	99.11	89.67	90.90	86.95	50.99	7961.5	87.47
Terrey-Guadalupe	132	11	11	10	5.3	97.36	86.64	88.45	84.23	53.64	4322.7	74.49
Osillo-Mérida	60	11	11	10	5.3	94.35	86.02	85.72	82.56	54.75	3353.1	39.97
San-Hermosillo	60	11	11	10	5.3	94.35	85.95	85.72	82.53	54.72	3376.5	37.59

de:

N = Número de canales telefónicos

Ant. Tx = Diámetro de la antena transmisora

Ant. Rx = Diámetro de la antena receptora

EJEMPLO DE DISEÑO PARA

SCPC - ANALOGICO.

DATOS

757

Enlace

Transmisora: México

Receptora: Tijuana

Posición Geográfica

Latitud	19.35° N	32.5° N
Longitud	99.01° W	117.03 W
ASNМ	2.233 Km	0.016 Km

Datos estaciones terrenas:

	Diámetro de Ant.	Ganancia	Figura de Mérito
Estación transmisora	7.5 mts	50.50 dbi	---
Estación receptora	3.2 mts	---	19.70 dB/°K

Datos del satélite para esos dos puntos de enlace:

PIRE del satélite en saturación	36.20 dBw
Densidad de flujo para saturar el satélite	-82.00 dBw/m ²
Figura de Mérito del satélite	3.90 dB/°K
Atenuador de posición	0 dB
Back-off de entrada al satélite	11 dB
Back-off de salida del satélite	6 dB

Datos de la red

Número de canales totales de la red	1200
Factor de actividad	40 %
Canales activados por voz pre-asignados	FDMA
Número canales transmitidos por la est. terrena	5
Espaciamiento entre canales	30 KHz

Frecuencias de operación y márgenes de lluvia

Frecuencia de operación portadora ascendente	6.405 GHz
Frecuencia de operación portadora descendente	3.820 GHz
Márgenes de lluvia ascendente y descendente	1.5 dB

Datos de la señal*

Modulación	F.M.
Frecuencia máxima de banda base	3.1 KHz
Desviación pico de frecuencia	9.6 KHz
Ancho de banda de ruido del audio	3.1 KHz
Factor de ponderación	7 dB
Ventaja por compensar	17 dB

* Datos de la compañía Scientific Atlanta

Memoria de cálculoCálculo de las distancias

Las distancias de las estaciones terrenas al satélite ya fueron calculadas en el primer ejemplo de televisión caso a) y fueron:

$l_1 = 36428.99$ Km. Distancia que hay entre el satélite y México

$l_2 = 36956.428$ Km. Distancia que hay entre el satélite y Tijuana

Cálculo de la $[C/N_0]_U$ (ascendente)

$$[C/N_0]_U = W_s - 20 \log f(\text{GHz}) - 21.45 + [G/T]_s + 228.6 - B01$$

En el caso de SCPC es necesario calcular la cantidad de densidad de flujo requerida por canal SCPC de entrada al satélite y el PIRE del satélite por canal SCPC, para hacerlo procederemos de la siguiente forma:

Primero se calcula el número de canales activos que estarían -- presentes en forma simultánea en el transpondedor del satélite de la siguiente manera:

$$NCA = NCTR \times F.A. \text{ ----- (XVI)}$$

donde

NCA = Número de canales activos

NCTR = Número de canales total de la red o ranuras disponibles en el transpondedor

F.A. = Factor de actividad

luego

$$W_{s_{xscpc}} = W_s - 10 \log NCA \text{ dBw/m}^2 \quad (\text{XVII})$$

$$PIRE_{xscpc} = PIRE - 10 \log NCA \text{ dBw} \quad (\text{XVIII})$$

donde:

$$W_{s_{xscpc}} = \text{Densidad de flujo por canal SCPC}$$

$$PIRE_{xscpc} = \text{PIRE que entrega el satélite por canal SCPC}$$

Nótese que el W_{sxscpc} y el $PIRE_{xscpc}$ calculado anteriormente es como si se trabajara el TWT en saturación ya que aún no se toma en cuenta los Back-offs del satélite, estos se toman en cuenta hasta las ecuaciones de enlace ascendente y descendente.

Sustituyendo los datos antes tabulados en las ecuaciones.

$$NCA = (1200) (0.40)$$

$$NCA = 480 \text{ canales activos}$$

Cálculo de W_{sxscpc} y $PIRE_{xscpc}$

$$W_{sxscpc} = -82 - 10 \log 480$$

$$W_{sxscpc} = -108.81 \text{ dBw/m}^2$$

$$PIRE_{xscpc} = 36.20 - 10 \log 480$$

$$PIRE_{xscpc} = 9.38 \text{ dBw}$$

Sustituyendo W_{sxscpc} en W_s de la ecuación ascendente y los demás valores queda:

$$\left[\frac{C}{No} \right]_U = -108.81 - 20 \log 6.405 - 21.45 + 3.90 + 228.6 - 11$$

$$\left[\frac{C}{No} \right]_U = 75.109 \text{ dB} - \text{Hz}$$

Cálculo de $\left[\frac{C}{No} \right]_D$ (descendente).

$$\left[\frac{C}{No} \right]_D = P_{SM} - BO_o - L_d + \left[\frac{G}{T} \right]_E + 228.6 - Md$$

Sustituyendo $PIRE_{xscpc}$ en P_{SM} y los demás datos en la ecuación descendente

$$L_d = 92.45 + 20 \log f(\text{GHz}) + 20 \log (\lambda_2)$$

$$L_d = 92.45 + 20 \log (3.805) + 20 \log (36956.428)$$

$$L_d = 195.41 \text{ dB}$$

$$\left[\frac{C}{No} \right]_D = 9.38 - 6 - 195.41 + 19.7 + 228.6 - 1.5$$

$$\left[\frac{C}{No} \right]_D = 54.77 \text{ dB} - \text{Hz}$$

Cálculo de $\left[\frac{C}{No} \right]_{IM}$

Para sistemas de alta densidad de SCPC ocupando un transpondedor es posible calcular el valor de $\left[\frac{C}{N} \right]_I$ mediante la siguiente fórmula:

$$\left[\frac{C}{N} \right]_I = 4.7 + 10 \log \left(\frac{N}{n} \right) + 2 (BO_o) - - - (XIX)$$

Donde:

$\left[\frac{C}{N} \right]_{IM}$ = Relación de la portadora a potencia de ruido de in -
termodulación en el peor canal (central)

$N = NCTR$ = Ranuras disponibles en el transpondedor

$n = NCA$ = Número de canales activos

BO_0 = Back-off de salida

Sustituyendo datos en la ecuación (XIX)

$$\left[\frac{C}{N} \right]_{IM} = 4.7 + 10 \log \left(\frac{1200}{480} \right) + 2 \quad (6)$$

$$\left[\frac{C}{N} \right]_{IM} = 20.67$$

$$\left[\frac{C}{N_0} \right]_{IM} = \left[\frac{C}{N} \right]_{IM} + B_{IF}$$

Donde B_{IF} se puede calcular por la regla de Carson:

$$B_{IF} = 2 (f_m + Df) \quad - - - \quad (XX)$$

donde

f_m = Frecuencia máxima de banda base

Df = Desviación pico de frecuencia

$$B_{IF} = 2(3.1 + 9.7)$$

$$B_{IF} = 25.6 \text{ KHz}$$

$$\left[\frac{C}{N_0} \right]_{IM} = 20.67 + 10 \log (25.6 \times 10^3)$$

$$\left[\frac{C}{N_0} \right]_{IM} = 64.75 \text{ dB}$$

Cálculo de $\left[\frac{C}{N_0} \right]_T$:

$$\left[\frac{C}{N_0} \right]_T = 10 \log \left[\frac{1}{\frac{1}{\text{Antilog } 7.5109} + \frac{1}{\text{Antilog } 5.477} + \frac{1}{\text{Antilog } 6.475}} \right]$$

$$\left[\frac{C}{N_0} \right]_T = 54.31 \text{ dB - Hz}$$

Cálculo de $\left[\frac{C}{N} \right]_T$

$$\left[\frac{C}{N} \right]_T = 54.31 - 10 \log (25.6 \times 10^3)$$

$$\left[\frac{C}{N} \right]_T = 10.22 \text{ dB}$$

Cálculo de la $\left[\frac{S}{N} \right]$

La siguiente ecuación puede utilizarse para el cálculo de $\frac{S}{N}$

por canal SCPC

$$\left[\frac{S}{N} \right] = \left[\frac{C}{N} \right] + 10 \log 3 \left[\frac{A_f}{f_m} \right]^2 + 10 \log \left[\frac{B_{IF}}{2B_a} \right] + WTC \quad \text{--- (XXI)}$$

Donde:

A_f = Desviación pico de frecuencia

f_m = Frecuencia máxima de banda base

B_{IF} = Ancho de banda de ruido de frecuencia intermedia

Ba = Ancho de banda de ruido de audio

W = Factor de mejoramiento por énfasis

c = Ventaja por compensar

Sustituyendo los datos en la ecuación (XXI):

$$\left[\frac{S}{N} \right] = 10.22 + 10 \log 3 \left[\frac{9.6 \times 10^3}{3.1 \times 10^3} \right]^2 + 10 \log \frac{25.6 \times 10^3}{2(3.1 \times 10^3)} + 7 + 17$$

$$\left[\frac{S}{N} \right] = 54.96 \text{ dB}$$

Cálculo del HPA

$$\text{PIRE}]_{ET} = W_s x s c p c + 10 \log 4 \pi \lambda_1^2 + M_a - B O_1$$

$$\text{PIRE}]_{ET} = - 108.81 + 10 \log 4 \pi (36428.99 \times 10^3)^2 + 1.5 - 11$$

$$\text{PIRE}]_{ET} = 43.91 \text{ dBw}$$

$$\text{HPA} = \text{PIRE}]_{ET} - G_A + L_{ET} + B O_{\text{HPA}}$$

$$\text{HPA} = 43.91 - 50.50 + 3 + 0$$

$$\text{HPA} = - 3.58 \text{ dBw}$$

$$\text{HPA} = 0.4385 \text{ watts X canal SCPC}$$

Como estamos transmitiendo 5 canales es necesario multiplicar

el HPA x 5:

HPA = 0.4385 X 5

HPA = 2.1915 watts para 5 canales SCPC

EJEMPLO DE DISEÑO PARA

SCPC DIGITAL

DATOSEnlace:

Transmite: México

Recibe: Tijuana

Datos Geográficos:

Latitud	19.35° N	32.5° N
Longitud	99.01° W	117.03° W
ASNМ	2.223 Km.	0.016 Km.

Datos estaciones terrenas

	Diámetro Ant.	Ganancia	Figura de Mérito
Transmisora	7.5 Mts.	50.50 dBi	---
Receptora	3.2 Mts.	---	19.70 dB/°K

Datos del satélite para estos dos puntos de enlace

PIRE del satélite en saturación	36.20 dBw
Densidad de flujo de saturación del satélite	-82.00 dBw/m ²
Figura de Mérito del satélite	3.90 dB/°K
Atenuador de posición	0 dB
Back-off de entrada al satélite	11 dB
Back-off de salida del satélite	6 dB

Datos de la red

Número de canales total de la red	800
Factor de actividad	40 %

Número de canales transmitidos por la est. terrena	5
Espaciamiento entre canales	30 KHz

Datos de frecuencias y márgenes de lluvia

Frecuencia portadora ascendente	6.405 GHz
Frecuencia portadora descendente	3.820 GHz
Márgenes de lluvia ascendente y descendente	1.5 dB

Datos de la señal*

Tipo de modulación digital	ADPCM **
Ancho de banda del canal de audio	300-3400 Hz
Velocidad de transmisión	33.3 kb/s
Ancho de banda de FI	16.6 KHz
Modulación	FSK 4 fases
Bit-error-rate (BER) para voz	10^{-4}

* Datos utilizados por la compañía japonesa NEC

** PCM adaptivo diferencial

Memoria de cálculo

El cálculo de las distancias de las estaciones terrenas (transmisora y receptora) al satélite y fueron calculados en el primer ejemplo de estas notas, resultando los siguientes valores:

$$l_1 = 36428.994 \text{ Km} \quad \text{Distancia de México al Morelos I}$$

$$l_2 = 36956.42 \quad \text{Distancia de Tijuana al Morelos I}$$

Cálculo de $[C/No]_U$ (ascendente)

$$[C/No]_U = W_s - 21.45 - 20 \log (f) + [G/T]_s + 228.6 - B0i$$

$$W_{sxscpc} = W_s - 10 \log NCA$$

$$NCA = NCT \times FA$$

Sustituyendo valores:

$$NCA = (800) (0.40) = 320$$

$$W_{sxscpc} = -82 - 10 \log 320$$

$$W_{sxscpc} = -107.05 \text{ dBw/m}^2$$

Sustituyendo W_{sxscpc} en W_s en la ecuación de enlace ascendente

$$\left[\frac{C}{No} \right]_U = -107.05 - 21.45 - 20 \log (6.405) + 3.9 + 228.6 - 11$$

$$\left[\frac{C}{No} \right]_U = 76.86 \text{ dB} - \text{Hz}$$

Cálculo del $\left[\frac{C}{No} \right]_D$ (descendente)

$$\left[\frac{C}{No} \right]_D = P_{SM} - BO_o - L_d + \left[\frac{G}{T} \right]_E + 228.6 - M_D$$

$$PIRE_{xscpc} = PIRE \left]_{sat} - 10 \log NCA$$

$$PIRE_{xscpc} = 36.20 - 10 \log 320$$

$$PIRE_{xscpc} = 11.14 \text{ dBw}$$

$$L_d = 92.45 + 20 \log f(\text{GHz}) + 20 \log l_2 \text{ (Km)}$$

$$L_d = 92.45 + 20 \log 3.82 + 20 \log 36956.42$$

$$L_d = 195.44 \text{ dB}$$

Sustituyendo $PIRE_{xscpc}$ en P_{sm} , L_d y los demás parámetros conocidos (datos) en la ecuación del enlace descendente:

$$\left[\frac{C}{No} \right]_D = 11.14 - 6 - 195.44 + 19.7 + 228.6 - 1.5$$

$$\left[\frac{C}{No} \right]_D = 56.5 \text{ dB} - \text{Hz}$$

Cálculo de $\left[\frac{C}{N_0} \right]_{IM}$

En este caso utilizaremos un valor típico de $\frac{C}{N_0} = 19.9 \text{ dB}^*$ para transpondedores cargados uniformemente por portadoras SCPC digital (40PSK) igualmente especiales y de igual potencia.

$$\left[\frac{C}{N_0} \right]_{IM} = \frac{C}{N_0} + 10 \log B_{IF}$$

$$\left[\frac{C}{N_0} \right]_{IM} = 19.9 + 10 \log 16.6 \times 10^3$$

$$\left[\frac{C}{N_0} \right]_{IM} = 62.10 \text{ dB} - \text{Hz}$$

Cálculo de $\left[\frac{C}{N_0} \right]_T$

$$\left[\frac{C}{N_0} \right]_T = 10 \log \left[\frac{1}{\frac{1}{\text{Antilog } 7.68} + \frac{1}{\text{Antilog } 5.65} + \frac{1}{\text{Antilog } 6.21}} \right]$$

$$\left[\frac{C}{N_0} \right]_T = 55.41 \text{ dB} - \text{Hz}$$

Después de haber obtenido el $\left[\frac{C}{N_0} \right]_T$ se calculara el $\left[\frac{C}{N_0} \right]_R$ (relación portadora a densidad ruido requerida) para obtener un BER de 10^{-4} especificado para voz por medio de la siguiente ecuación.

$$\left[\frac{C}{N_0} \right]_R = E_b/N_0 + 10 \log BR + MI - - - \text{(XXI)}$$

* Valor utilizado por INTELSAT. Nótese que no se utilizó la ecuación

Donde:

E_b/N_o = Energía/bit por hertz

BR = velocidad de bits transmitidos

MI = 1.5dB=Márgen de implementación (valor típico promedio)

El valor de E_b/N_o puede calcularse a partir de la curva en la fig. 2 donde para un BER de 10^{-4} corresponde un valor de 8.4 dB. Nótese que esta curva es ideal por lo cual en la ecuación de $\left[\frac{C}{N_o} \right]_R$ se suma un margen de implementación.

Sustituyendo datos en la ecuación

$$\left[\frac{C}{N_o} \right]_R = 8.4 + 10 \log 33.3 \times 10^3 + 1.5$$

$$\left[\frac{C}{N_o} \right]_R = 55.12 \text{ dB} - \text{Hz}$$

Comparando $\left[\frac{C}{N_o} \right]_R$ con $\left[\frac{C}{N_o} \right]_T$ obtenido del radio enlace se visualiza que

$$\left[\frac{C}{N_o} \right]_T > \left[\frac{C}{N_o} \right]_R$$

De esto se deduce que nuestro enlace está trabajando correctamente.

Cálculo del HPA.

$$\text{PIRE}]_{ET} = W_{\text{sxscpc}} + 10 \log 4\pi f_1^2 + M_A - BO_i$$

Sustituyendo valores

$$\text{PIRE}]_{ET} = -107.05 + 10 \log 4\pi (36428.99 \times 10^3)^2 + 1.5 - 11$$

$$\text{PIRE}]_{ET} = 45.61 \text{ dBw x canal SCPC}$$

$$\text{HPA} = \text{PIRE}]_{ET} - G_A + L_{ET} + BO_{\text{HPA}}$$

$$\text{HPA} = 45.61 - 50.5 + 3 + 0$$

$$\text{HPA} = -1.89 \text{ dBw}$$

$$\text{HPA} = 0.6471 \text{ watts}$$

Como estamos transmitiendo 5 canales es necesario multiplicar el HPA x 5.

$$\text{HPA} = 0.6471 \times 5$$

$$\text{HPA} = 3.235 \text{ watts para transmitir 5 canales SCPC}$$

A N E X O S

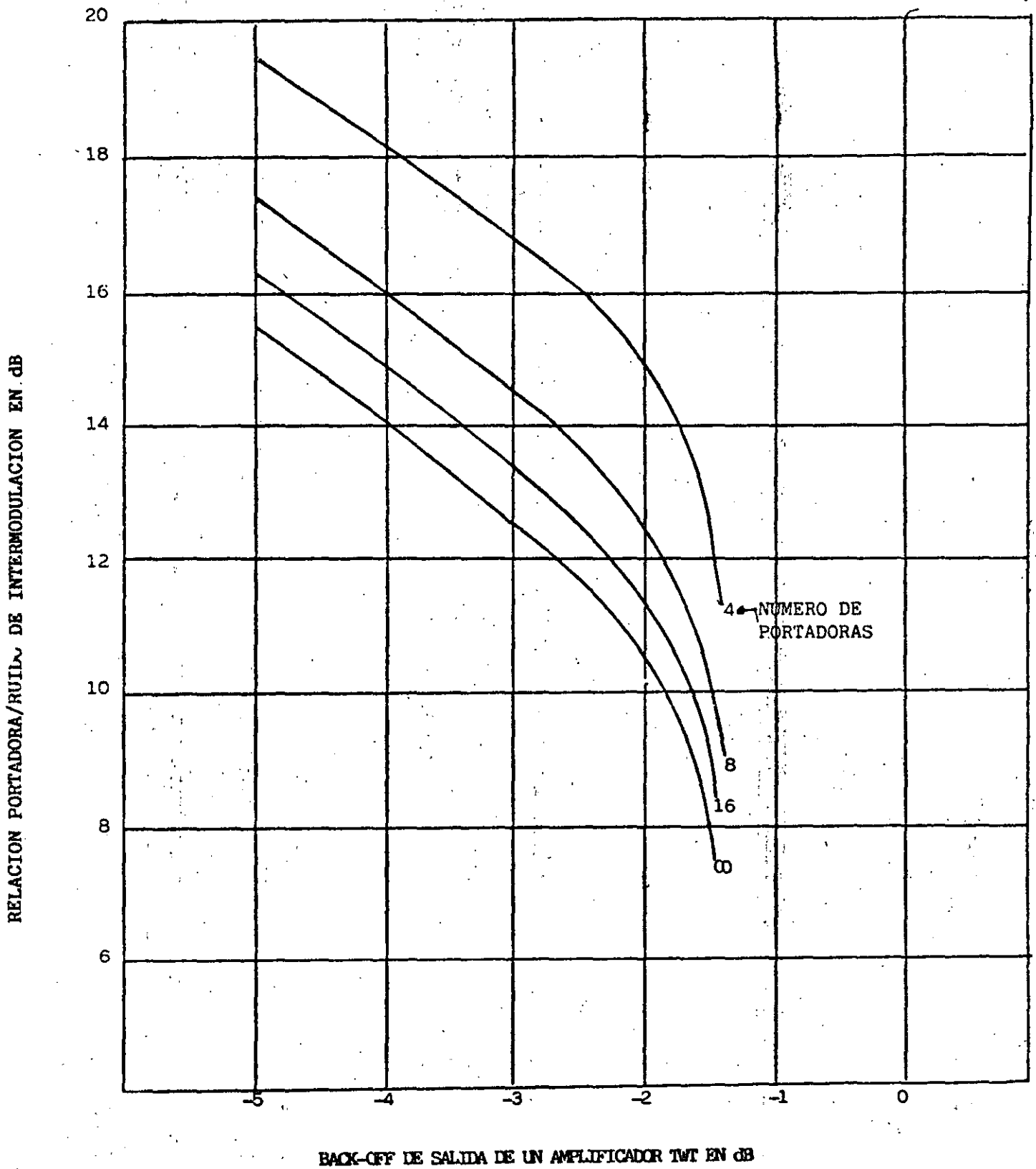


FIG. 1 RELACION PORTADORA/RUIDO DE INTERMODULACION EN FUNCION DEL BACK-OFF PARA UN AMPLIFICADOR TWT TIPICO

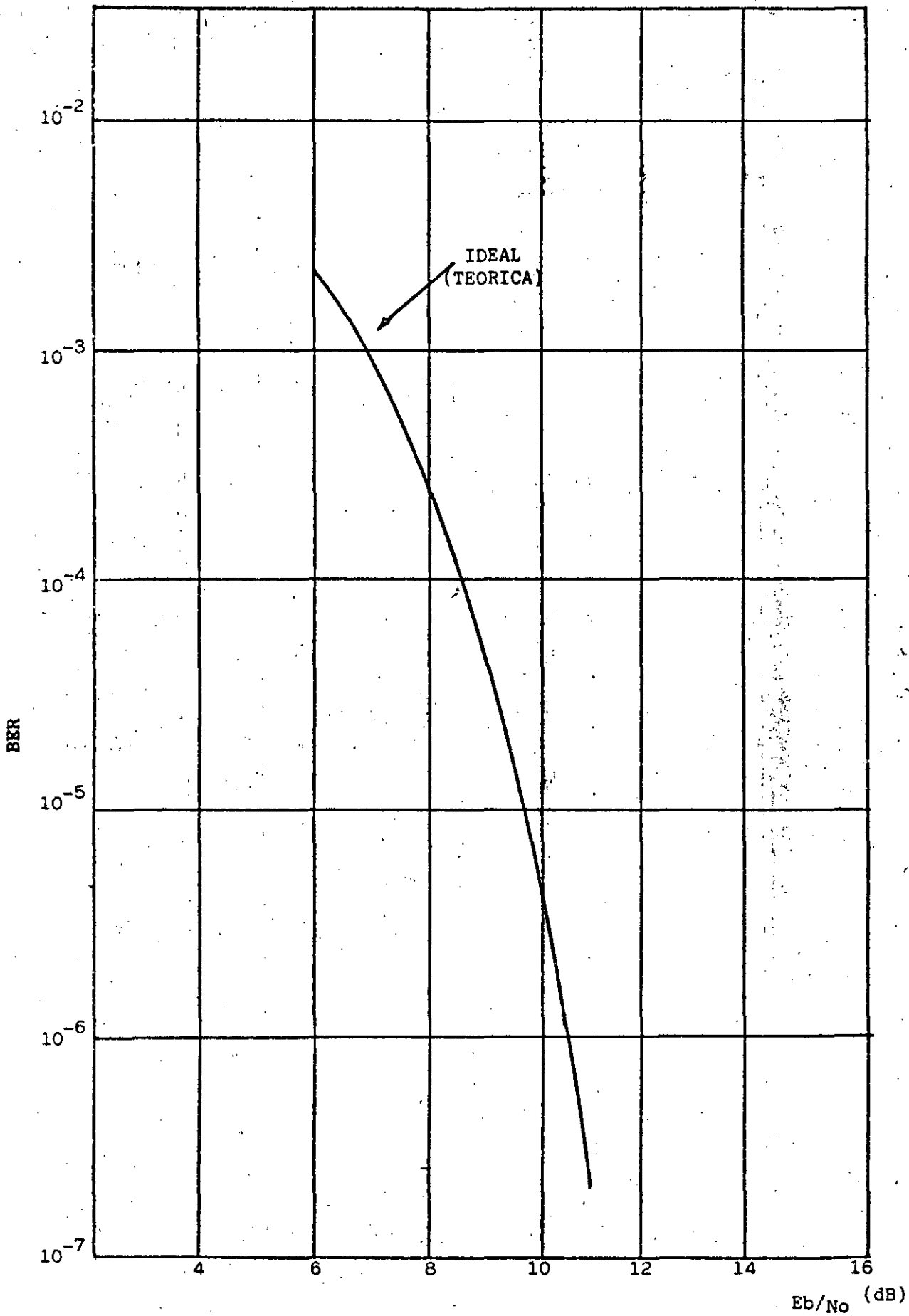


FIG.2 BIT ERROR RATE PARA UN MODEM SCPC-PSK

Cuadro 3.15
Parámetros de transmisión para los satélites INTELSAT IV-A, V, V-A y VI
(Portadoras FDM/FM normales)

Carrier Capacity (Number of Channels)	Top Baseband Frequency (kHz)	Allocated Satellite BW Unit (Mhz)	Occupied Bandwidth (Mhz)	Deviation (rms) for 0 dBm0 Test Tone (kHz)	Multichannel rms Deviation (kHz)	Carrier-to-Total Noise Temperature Ratio at Operating Point (8000 + 200 p/Co from RF Sources) (dBm/K)	Carrier-to-Noise Ratio in Occupied BW (dB)	Ratio of Unmodulated Carrier Power to Max. Carrier Power Density Under Full Load Conditions (dB/4 kHz)
n	f ₀	b _a	b _o	f _{mc}	f _{mc}	C/T	C/N	
12 +	60	1,25	1,125	109	159	- 154,7	13,4	20,0
24	108	2,5	2,00	164	275	- 153,0	12,7	22,3
36	156	2,5	2,25	168	307	- 150,0	15,1	22,6
48	204	2,5	2,25	151	292	- 146,7	18,4	22,6
60	252	2,5	2,25	136	276	- 144,0	21,1	22,4
60	252	5,0	4,0	270	546	- 149,9	12,7	25,3
72	300	5,0	4,5	294	616	- 149,1	13,0	25,8
96	408	5,0	4,5	263	584	- 145,5	16,6	25,6
132	552	5,0	4,4	223	529	- 141,4	20,7	24,2*(X=1)
96	408	7,5	5,9	360	799	- 145,2	12,7	27,0
132	552	7,5	6,75	376	891	- 145,9	14,4	27,5
192	804	7,5	6,4	297	758	- 140,6	19,9	25,8*(X=1)
132	552	10,0	7,5	430	1020	- 147,1	12,7	28,0
192	804	10,0	9,0	457	1167	- 144,4	14,7	28,6
252	1052	10,0	8,5	358	1009	- 139,9	19,4	27,0*(X=1)
252	1052	15,0	12,4	577	1627	- 144,1	13,6	30,0
312	1300	15,0	13,5	546	1716	- 141,7	15,6	30,2
372	1548	15,0	13,5	480	1645	- 135,9	16,4	30,1
432	1796	15,0	13,0	401	1479	- 136,2	21,2	27,6*(X=2)
432	1796	17,5	15,75	517	1919	- 138,5	18,2	30,8
432	1796	20,0	18,0	616	2276	- 139,9	16,1	31,5
492	2044	20,0	18,0	558	2200	- 137,8	18,2	31,4
552	2292	20,0	18,0	508	2121	- 136,0	20,0	30,2*(X=1)
432	1796	25,0	20,7	729	2688	- 141,4	14,1	32,2
492	2044	25,0	22,5	730	2911	- 140,3	14,8	32,6
552	2292	25,0	22,5	678	2833	- 135,5	16,6	32,5
612	2540	25,0	22,5	626	2755	- 135,9	18,1	32,4
792	3284	36,0	32,4	816	4085	- 137,0	16,5	34,1
972+	4028	36,0	32,4	694	3849	- 133,8	19,7	32,8*(X=1)
972	4028	36,0	36,0	802	4417	- 135,2	17,8	34,5
1092**	4692	36,0	36,0	701	4118	- 132,4	20,7	32,2*(X=2)

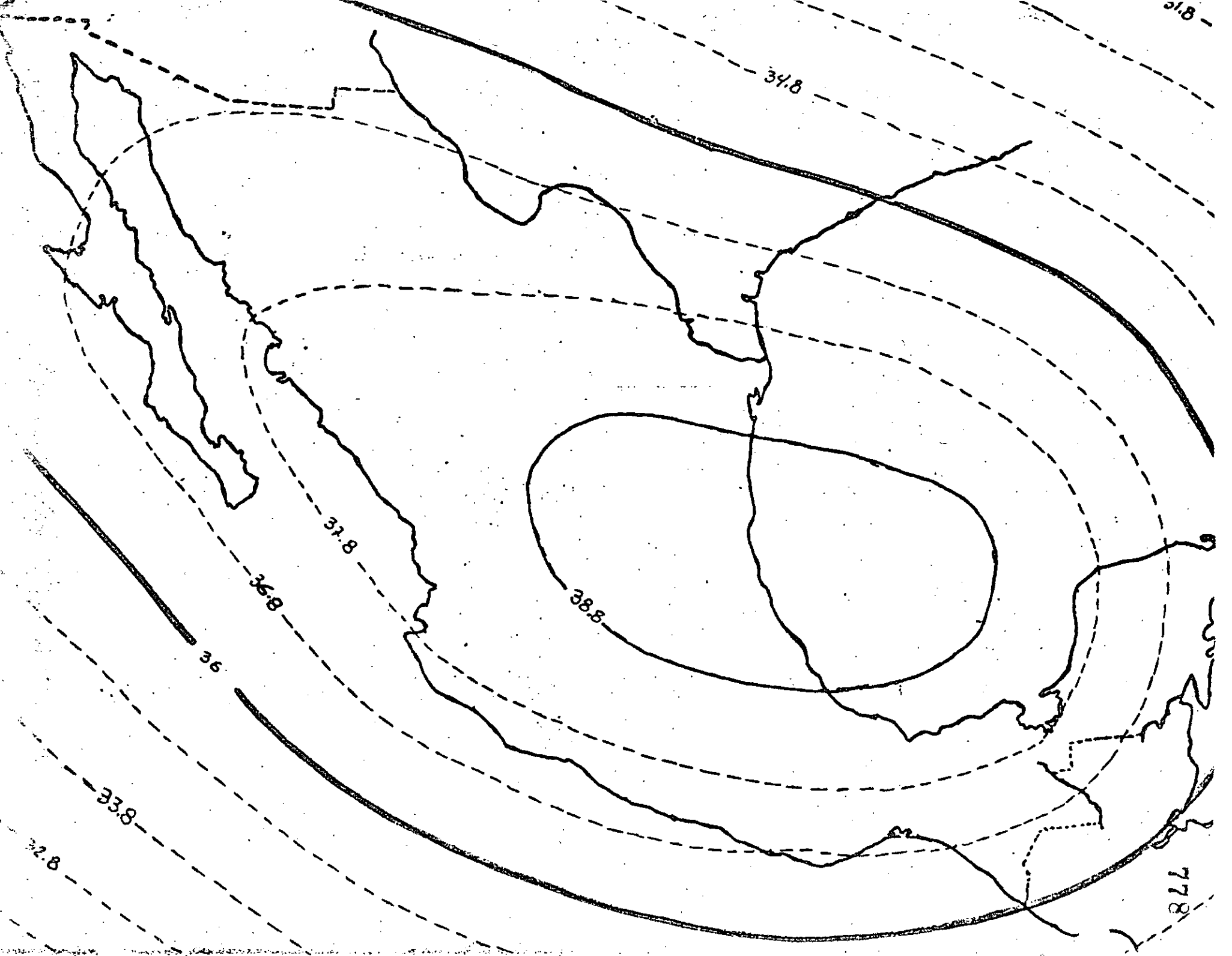
* Este valor es X dB menor que el calculado conforme a la fórmula normal empleada para obtener esta relación, o sea,

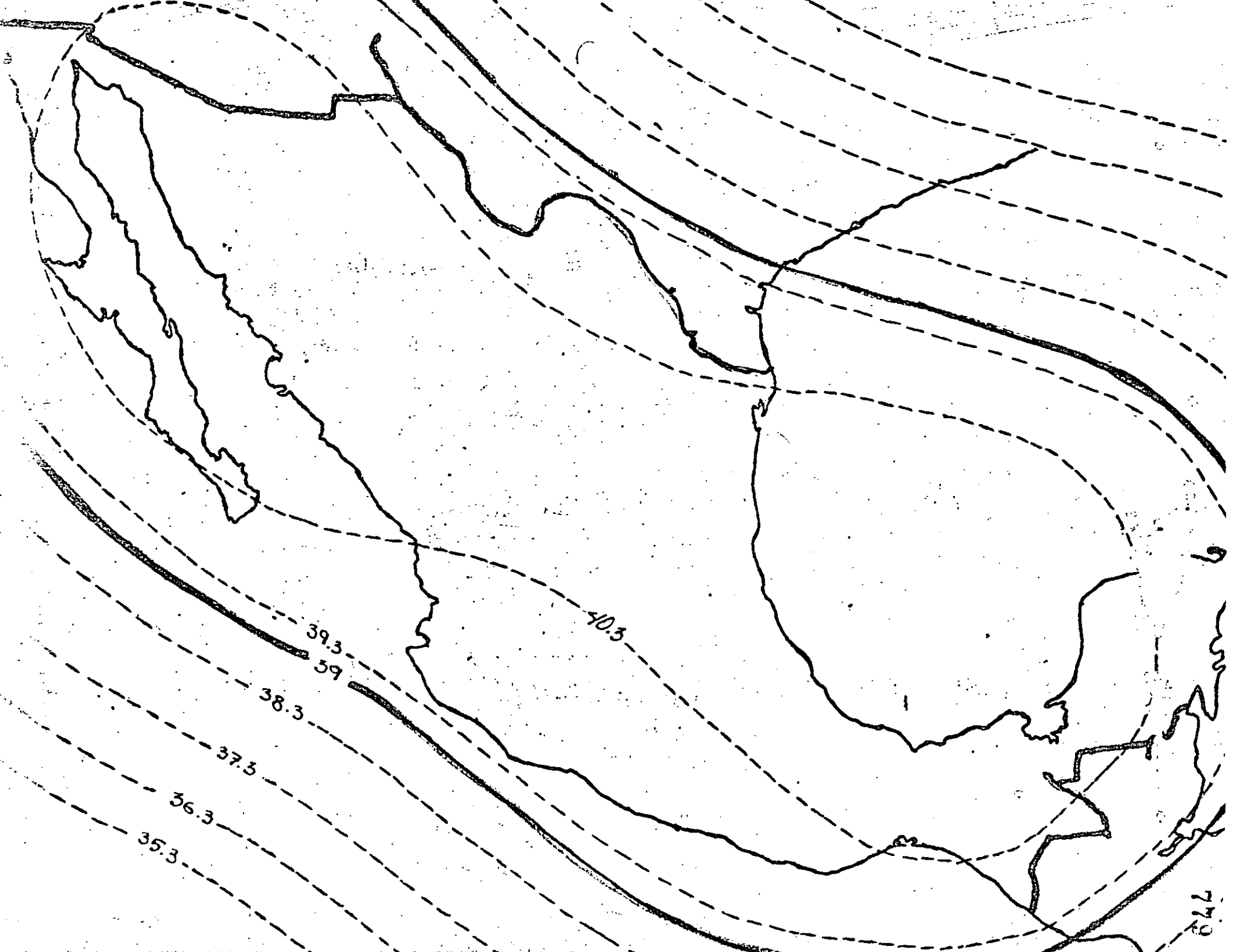
$$10 \log_{10} \left(\frac{f_{mc}}{\sqrt{2} \pi / 4} \right)$$

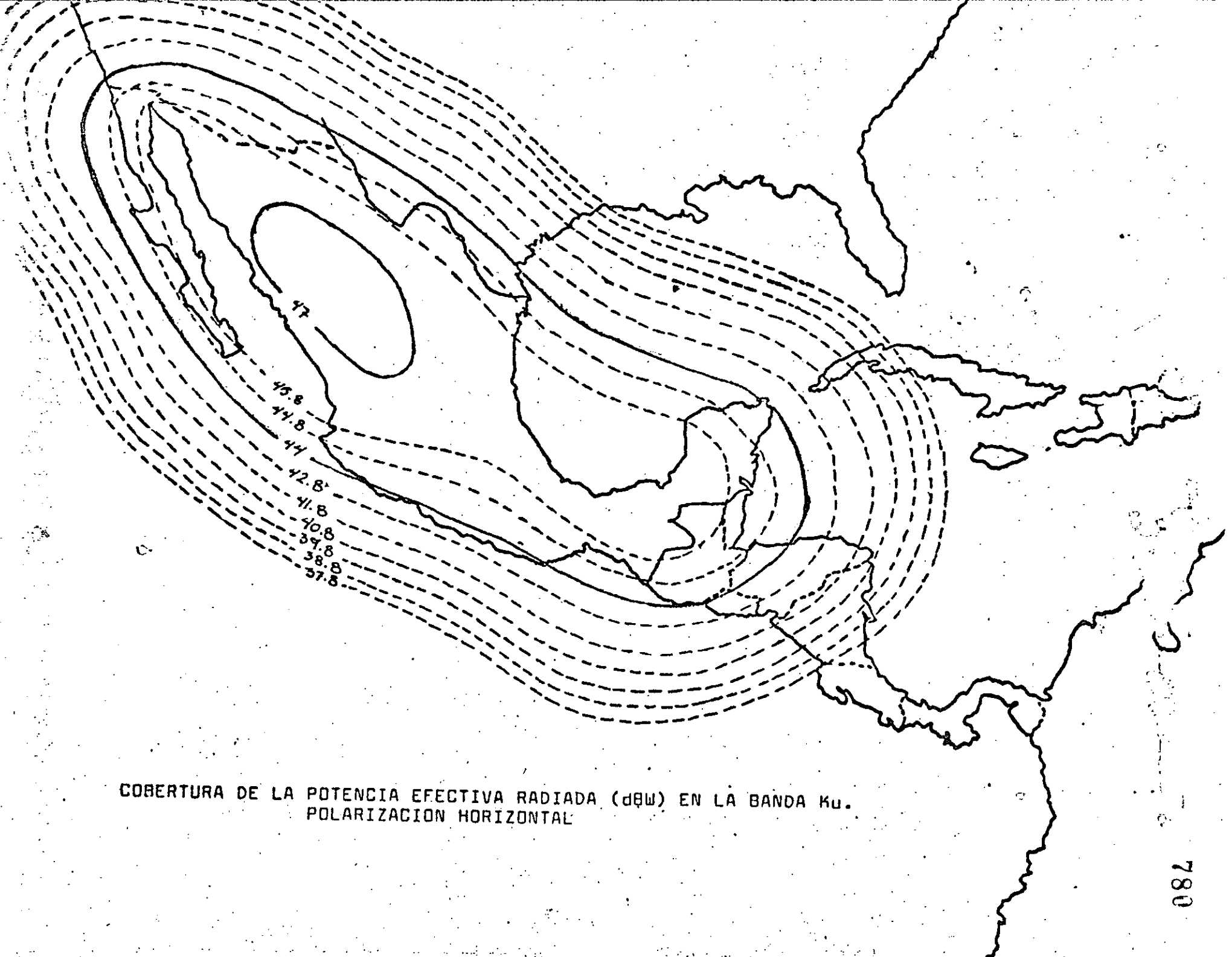
donde: X es el valor entre paréntesis de la última columna y f_{mc} es la desviación cuadrática de canales múltiples, en kHz. Este factor es necesario a fin de poder compensar las portadoras de bajo índice de modulación que se considera no tienen una distribución gaussiana de densidad de potencia.

** No se utiliza con el INTELSAT V, V-A o VI (Aprobada únicamente para el INTELSAT IV-A).

† No se utiliza con el INTELSAT IV-A.



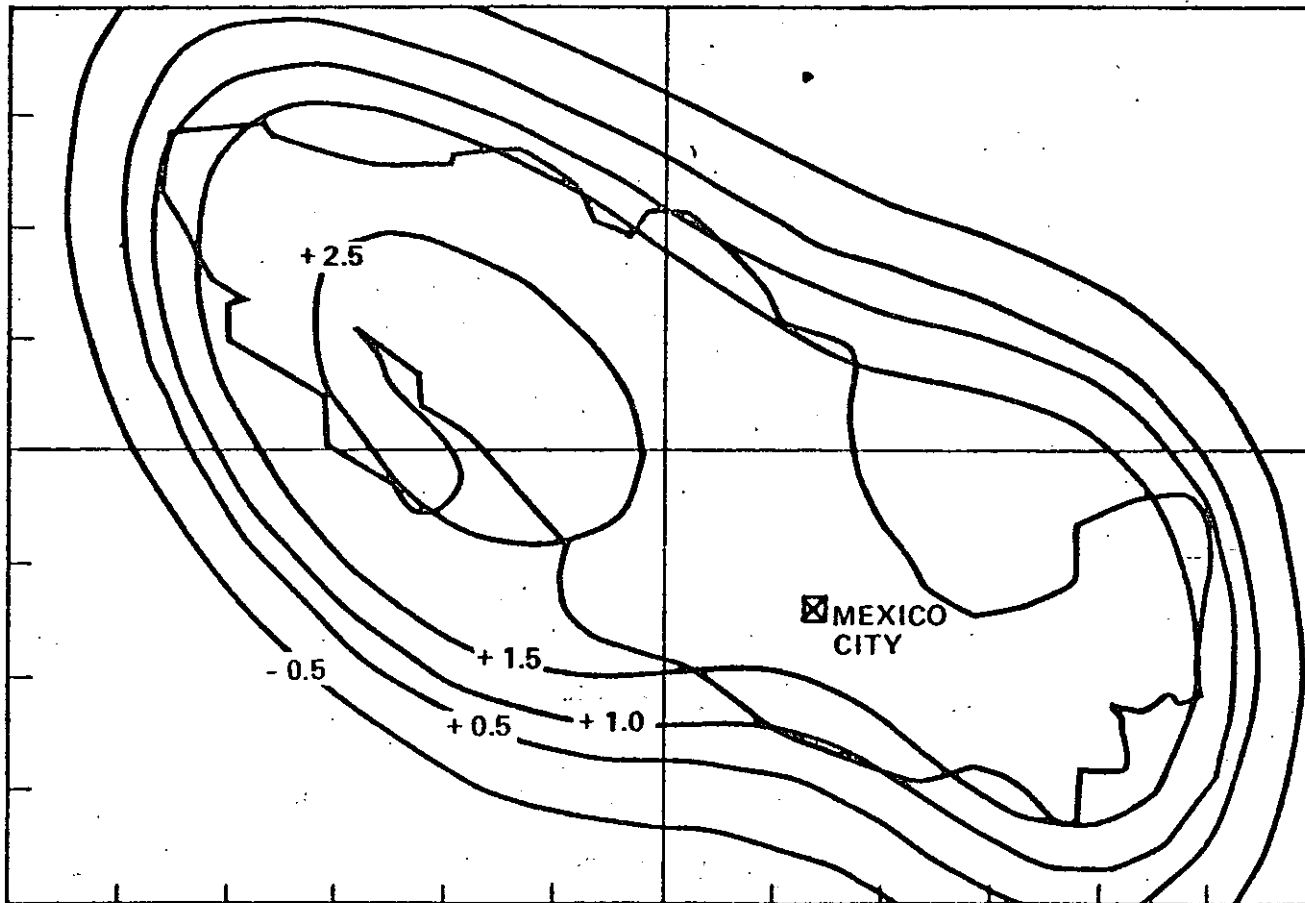


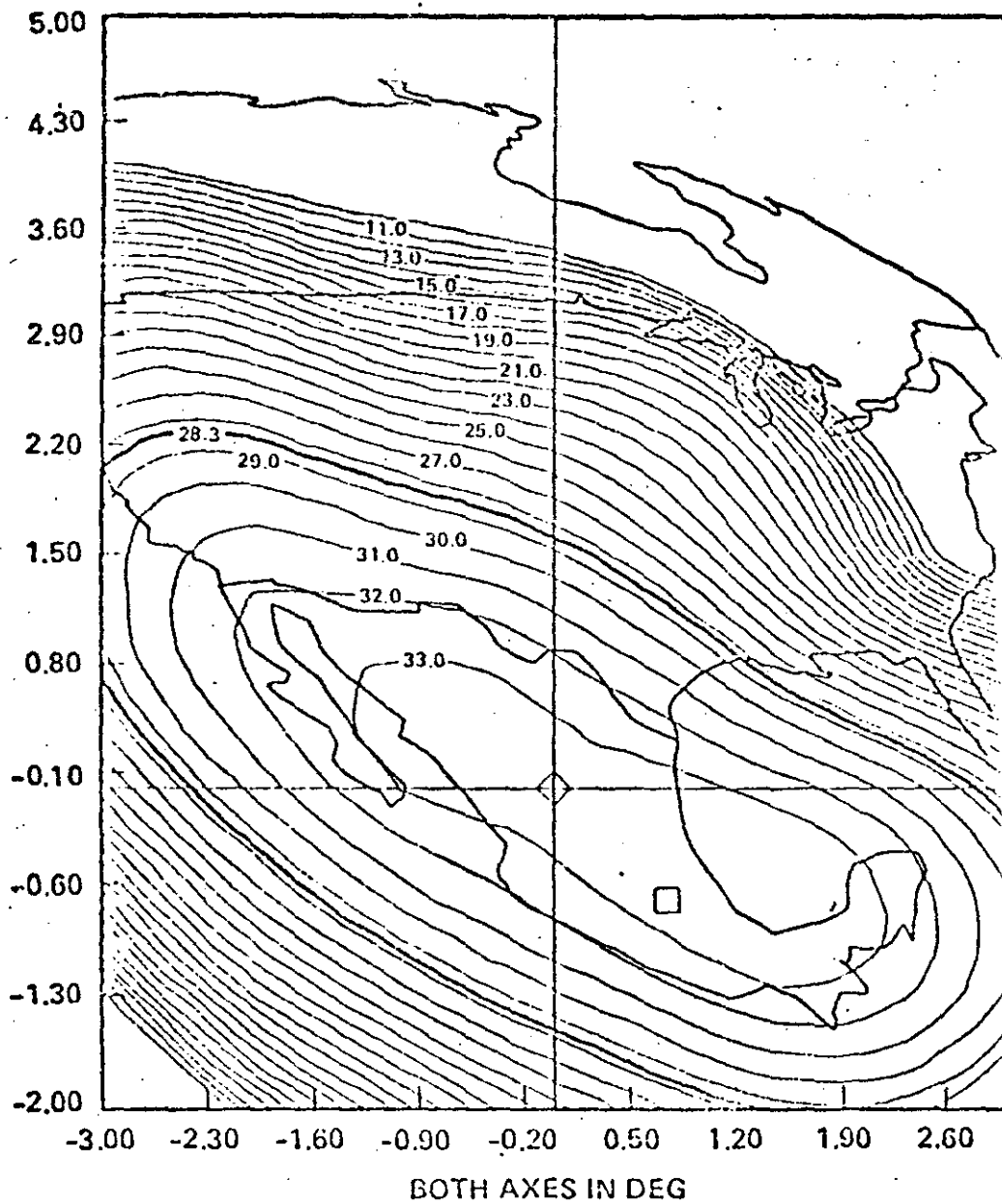


COBERTURA DE LA POTENCIA EFECTIVA RADIADA (dBW) EN LA BANDA Ku.
POLARIZACION HORIZONTAL

K BAND RECEIVE G/T PATTERN PLANAR ARRAY

HUGHES
HUGHES AIRCRAFT COMPANY





HUGHES

HORIZONTAL C
BAND RECEIVE

846185-159

ZONA GEOGRAFICA	CONFIABILIDAD				
	99.99	99.98	99.95	99.90	99.80%
NOR OCCIDENTE	8.4	7.0	5.1	3.4	3.2
NORTE CENTRO	5.6	4.3	2.3	2.0	1.9
GOLFO NORTE	12.8	11.5	9.5	7.8	7.6
CENTRO	9.7	8.3	6.4	4.7	4.5
PACIFICO CENTRO	11.1	9.7	7.8	6.1	5.9
ITSMD	11.1	9.8	7.8	6.1	5.9
YUCATAN	10.4	9.0	7.1	5.4	5.2

TABLA 4

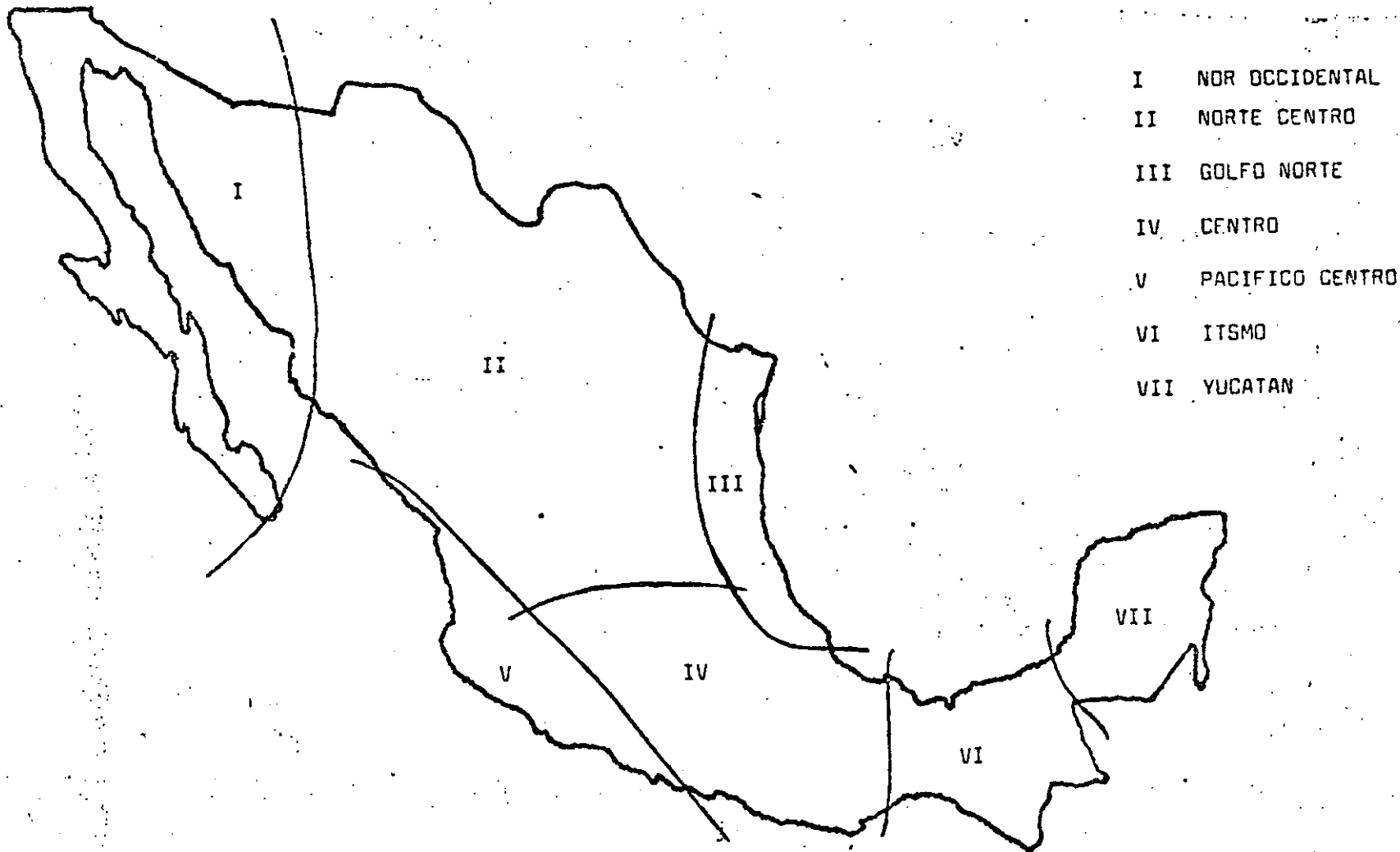


FIGURA 7

FM Television Signal-to-Noise Ratio

LORIMER CLAYTON
Scientific-Atlanta, Inc.

Abstract. For a frequency-modulation relay link carrying television, a simple general form is suggested for the relationship between baseband signal-to-noise ratio and the ratio of carrier power to noise power density applied to the receiver discriminator. The bandlimiting, emphasis, and weighting functions prescribed by various standards are characterized by effective noise bandwidths with respect to triangular noise.

I. Signal-To-Noise Ratio Equation. In analysis of frequency-modulation relay links carrying television, one calculates a predicted value of C/N_0 : the ratio of carrier power to noise power density in the receiver intermediate-frequency circuits. It is usually of interest next to calculate the corresponding theoretical baseband signal-to-noise ratio which should result from a measurement procedure prescribed by a certain standard, on the assumption that the system is operating well above threshold. The equation employed in this step has been expressed in a remarkable variety of ways. It is suggested that the simplest general form is the following:

$$(S/N)_b = \frac{C}{N_0} \left[\frac{12 (\Delta F_s)^2}{b_b^3} \right] \quad (1)$$

where

- C = carrier power (watts)
- N_0 = noise power density at that point in the receiver where C is measured = kT_s (watts/MHz)
- k = Boltzmann's constant = 1.3806×10^{-17} W/MHz/°K
- T_s = system operating noise temperature referred to that point in the system where C is measured (°K)
- ΔF_s = half of the peak-to-peak deviation produced by that part of the video waveform which is defined to be the "signal" (MHz)
- b_b = noise bandwidth of the baseband filter function (representing the combination of the deemphasis network, measurement bandlimiting filter, and weighting network [when used]) with respect to "triangular" noise (MHz)

$$= \left[3 \int_0^F f^2 |H(f)|^2 df \right]^{1/3}$$

$H(f)$ = product of deemphasis, bandlimiting filter, and weighting (if used) transfer functions

F = an integration limit frequency high enough so that $H(f)$ may be considered zero above F.

The definition of $(S/N)_b$ and a derivation are given in the Appendix.

In decibels, $(S/N)_b$ is 10 times the logarithm of the numeric ratio expression.

Note that $(S/N)_b$ is not a function of IF bandwidth or modulating frequency. The relation (or any of its variants) is applicable, however, only when the IF bandwidth is at least adequate to support the signal.

II. Standards and Parameters. Equation (1) is sufficiently general to accommodate any standard by specifications of the appropriate ΔF_s and b_b . Those cases for which we have carried out the necessary numerical integration are listed in Table I. The notation is the following:

- ΔF_s = half of the peak-to-peak deviation produced by the video waveform including sync tips
- D = deemphasis response per CCIR Rec. 405-1
- W = weighting network response
- F = low-pass bandlimiting filter per CCIR Rec. 421-3 (except RS-250-A)

We assume lossless network inductors, and omit the specified hum-elimination high-pass filters (which have negligible effect for triangular noise). Otherwise we have avoided approximations (e. g., truncation at the upper baseband frequency) except as indicated in the comments which follow.

A property of weighting is worth mentioning. A result obtained by Straus (1) is widely known in the cable television industry: if a given baseband signal is obtained from the output of a vestigial-sideband TV demodulator

Table I

<u>Standard</u>	<u>ΔF_v</u>	<u>Unweighted $b_n(D, F)$ MHz</u>	<u>Weighted $b_n(D, W, F)$ MHz</u>
525 Line System M (USA/Canada)			
CCIR Rec. 421-3 (1974) NTC Rep. No. 7 (1975) }	0.714 ΔF_v	3.357	1.574
EIA RS-250-A (1967)	ΔF_v	-----	2.22
Bell Telephone Labs (1971)	ΔF_v	-----	1.574
Proposed: CCIR Rep. 410-2 (1974) EIA Prop. 1193 (1974) }	0.714 ΔF_v	3.960	1.608
625 Line Systems B, C, G, H (5 MHz) and D, K, L (6 MHz)			
CCIR Rec. 421-3 5 MHz	0.700 ΔF_v	4.295	1.425
CCIR Rec. 421-3 6 MHz	0.700 ΔF_v	5.052	1.483
Proposed: CCIR Rep. 410-2 5 and 6 MHz	0.700 ΔF_v	4.295	1.811

having an ideal Nyquist-slope IF filter and the quality of this signal is assessed first according to CCIR 421-3 and then according to EIA RS-250-A. the RS-250-A recipe gives a number which is 0.3 dB better than that given by the 421-3 recipe. One should not conclude that this is also the difference for a given baseband signal obtained from the output of an ideal FM relay link. For this case (S/N), according to RS-250-A is worse than that according to 421-3 by

$$30 \log (2.22/1.574) + 20 \log (0.714) = 1.55 \text{ dB.}$$

The two weightings represent incompatible assessments of the subjective effects of frequency-dependent noise, differing by 4.5 dB here.

1. CCIR Rec. 421-3 (525-line) (ref. 2). This is the standard currently used by the domestic satellite communications industry. It has been adopted by the Network Transmission Committee of the Video Transmission Engineering Advisory Committee (3), a joint committee of television network broadcasters and the Bell System. The "signal" is the luminance part of the video waveform.

The CCIR measurement setup has a band-limiting low-pass filter which is separate from the weighting network. It is therefore possible to make a meaningful measurement without the weighting network. For deemphasized triangular noise the expected difference between a weighted

and an unweighted measurement is

$$30 \log \frac{b_n(D, F)}{b_n(D, W, F)} = 9.9 \text{ dB.}$$

2. EIA RS-250-A (ref. 4). This standard has been widely used in the domestic ground microwave relay industry. It is presently under revision. The "signal" is the entire video waveform.

The weighting is somewhat ambiguous. We interpret the "standard" as being Barstow and Christopher's 1962 color weighting curve (5). Using it, we get agreement with Straus (1) and with Lenkurt (6). The recommended network, at least with ideal inductors, does not match the curve very closely. It gives an 0.8-dB worse (S/N).

The bandlimiting filter is an integral part of the weighting network; one cannot make a well-defined "unweighted" measurement.

3. Bell Telephone Laboratories (ref. 7). This procedure uses the RS-250-A definition of signal and the 421-3 weighting.

4. CCIR Report 410-2 (ref. 8). A new unified weighting network used with a 5 MHz bandlimiting filter is proposed for all international television circuits. EIA Proposal 1193 (ref. 9) and CCIR Report 486-1 (ref. 10) adopt it.

The internal baseband response of 525-line receivers need not be flat above 4.2 MHz, and rolloff can affect measurements. Weighted deemphasized noise between 4.2 and 5 MHz contributes 1.3 dB to the total noise integral.

5. CCIR Rec. 421-3 (625-line systems). A slight roundoff ambiguity exists in the weighting time-constant tabulated in 421-3. We use the specification that for the 6 MHz systems, the time constant multiplied by 6 MHz is exactly two ($\tau = 1/3 \mu s$). The resulting difference between weighted and unweighted measurements (systems D, K, L) is

$$30 \log \frac{5.052}{1.483} = 16.0 \text{ dB}$$

CCIR Report 637 (ref. 11) uses the specification that $\tau = 0.33 \mu s$ and gets 15.8 dB. For the 5 MHz systems we differ by 0.1 dB.

III. Examples.

1. A certain satellite link uses 10.75 MHz peak deviation. Predict performance according to CCIR Rec. 421-3 (USA/Canada).

$$\begin{aligned} (S/N)_e &= \left(\frac{C}{N_0} \right)_{\text{dB MHz}} \\ &+ 10 \log \left[\frac{12 (0.714 \times 10.75)^2}{(1.574)^3} \right] \\ &= \left(\frac{C}{N_0} \right)_{\text{dB MHz}} + 22.6 \text{ dB MHz}^{-1} \end{aligned}$$

Note the megahertz units of the ratio of carrier power to noise power density.

2. For the special case of ground microwave relay links with a peak deviation $\Delta F_v = 4$ MHz, Lenkurt's handbook (6) gives this decibel relationship:

$$(S/N)_e = C_{\text{dB}} - F + A$$

where F is the operational noise figure

$$F = 10 \log \frac{T_s}{290}$$

and A depends upon the standard used as follows:

Case	Standard	A
1	EIA North America	126.5
2	CCIR 625-line, 5 MHz	129.0
3	CCIR 625-line, 6 MHz	128.6

Compare these results with ours:

$$(S/N)_e = C_{\text{dB}} - N_0 + 10 \log \left[\frac{12 \left(\frac{\Delta F_s}{\Delta F_v} \times 4 \right)^2}{b_s^3} \right]$$

$$C_{\text{dB}} = C_{\text{dB}} - 30$$

$$N_0 = 10 \log kT_s = F + 10 \log (k \times 290)$$

$$\begin{aligned} N_0 &= F + 10 \log (1.3806 \times 10^{-17} \times 290) \\ &= F - 143.98 \end{aligned}$$

$$\begin{aligned} (S/N)_e &= C_{\text{dB}} - F + 113.98 + 10 \log (12 \times 16) \\ &+ 20 \log \frac{\Delta F_s}{\Delta F_v} - 30 \log b_s \end{aligned}$$

Comparing terms,

$$A = 20 \log \frac{\Delta F_s}{\Delta F_v} - 30 \log b_s + 136.81$$

$$\text{Case 1: } \frac{\Delta F_s}{\Delta F_v} = 1, b_s = 2.22; A = 126.4$$

$$\text{Case 2: } \frac{\Delta F_s}{\Delta F_v} = 0.700, b_s = 1.425; A = 129.1$$

$$\text{Case 3: } \frac{\Delta F_s}{\Delta F_v} = 0.700, b_s = 1.483; A = 128.6$$

IV. Alternate Forms. The alternate forms of Equation 1 found in the literature look quite different at first glance. They can be obtained by applying one or more of the following modifications, which provide conveniences and insights for certain purposes. Some also introduce hazards of misinterpretation.

1. Constant Approximation. For those standards for which $\Delta F_s/\Delta F_v$ is either 0.714 or 0.700, replace the ratio by $1/\sqrt{2}$.

2. Introduction of Highest Video Modulating Frequency. Letting f_v be a hypothetical highest video modulating frequency, multiply numerator and denominator by f_v^3 . Retain the denominator term within the brackets, and extract an "advantage" factor $(f_v/b_s)^3$. In decibels,

$$A = 30 \log \frac{f_v}{b_s}$$

For example, for 421-3 USA/Canada, let $f_v = 4.2$.

$$A = 30 \log \frac{4.2}{1.574} = 12.8 \text{ dB}$$

Other numbers resulting from improper combination of partial advantages (weighting and deemphasis) are sometimes seen. This situation has been cleared up by CCIR Report 637 (ref. 1). One must still know what f_v has been assumed in the calculation of a published advantage in order to use the same number in the denominator.

A variant form multiplies numerator and denominator by only the square of f_v , factors out a 20-log advantage term, and leaves a first power of b_s in the denominator. This seems to be quite liable to misinterpretation.

3. Introduction of Another Bandwidth. Multiply numerator and denominator by a bandwidth B , forming the product $N_0 B$ in the denominator and placing the numerator factor inside the brackets.

If B is taken to be the IF noise bandwidth $B_{s, IF}$, the result is useful because the first factor becomes the IF signal-to-noise ratio C/N , where $N = N_0 B_{s, IF}$. One must know this anyway to determine threshold margin.

Some forms take B to be the Carson's rule bandwidth for video without audio subcarrier: $B_c = 2(\Delta F_v + f_v)$. The product $N_0 B_c$ in the denominator has no special significance.

The hazard lies in the inadvertent use of different numerator and denominator bandwidths; e.g., B_c in the numerator and $B_{s, IF}$ in the denominator.

4. Introduction of Modulation Index. Having introduced f_v , let $(\Delta F_v / f_v) = m$, a hypothetical modulation index.

V. Conclusion. In comparison with alternate forms, the simplicity of equation (1) appears to reduce the chance of making a mistake or a wrong interpretation.

Appendix. Some insight is provided by arriving at equation (1) without recourse to the known relationship for sinusoidal modulation.

We define television signal-to-noise ratio $(S/N)_t$ as a numeric ratio: the ratio of the square of the peak-to-peak "signal" voltage to the mean squared noise voltage at some baseband terminal, such as the output of a specified bandlimiting and weighting network. The equivalent decibel definitions of some standards correspond to 10 times the common logarithm of this ratio. It is not necessary at this point to impose a restriction as to what part of the video waveform constitutes the "signal".

An ideal frequency-modulation discriminator is a device whose output voltage is linearly proportional to the frequency of a waveform applied to it:

$$V_{out} = k_d (F_1 - F_0) \quad (A1)$$

F_0 = center frequency
 F_1 = input waveform frequency
 k_d = constant of proportionality

If the peak-to-peak deviation produced by that part of the video waveform which is defined to be the "signal" is $2\Delta F_s$, then the peak-to-peak signal voltage out of the discriminator is

$$v_{s, pp} = k_d 2\Delta F_s$$

and the "S" in $(S/N)_t$ is just

$$S = v_{s, pp}^2 = k_d^2 4(\Delta F_s)^2 \quad (A2)$$

To address the "N", first consider the presence at the discriminator input of an unmodulated carrier of frequency F_c (not necessarily F_0) and rms amplitude a_c . We will later remove the restriction that the frequency of this signal be constant. In addition, let a tiny sinusoid of rms amplitude a_s be applied at frequency $F_c + f$. The slipping of the little phasor with respect to the carrier phasor gives combined amplitude and phase modulation:

$$\text{Let } v_c = \sqrt{2} a_c \sin 2\pi F_c t$$

$$v_s = \sqrt{2} a_s \sin 2\pi (F_c + f)t$$

$$= \sqrt{2} a_s [\cos 2\pi ft \sin 2\pi F_c t + \sin 2\pi ft \cos 2\pi F_c t]$$

$$v = v_c + v_s = \sqrt{2} [(a_c + a_s \cos 2\pi ft) \sin 2\pi F_c t + a_s \sin 2\pi ft \cos 2\pi F_c t]$$

$$v = \sqrt{2} a_c \sqrt{1 + \left(\frac{a_s}{a_c}\right)^2 + 2\frac{a_s}{a_c} \cos 2\pi ft} \times \sin[2\pi F_c t + \phi(t)]$$

where

$$\phi(t) = \tan^{-1} \frac{\frac{a_s}{a_c} \sin 2\pi ft}{1 + \frac{a_s}{a_c} \cos 2\pi ft}$$

The radical term is the amplitude modulation and the $\phi(t)$ term is the phase modulation. We will make $\frac{a_s}{a_c}$ an infinitesimal, and in this limit the tangent of the angle becomes equal to the angle in radians. Also the alternating term in the denominator vanishes in comparison to the unit term:

$$\phi(t) \approx \frac{a_s}{a_c} \sin 2\pi ft$$

Thus we have a phase modulation which can be expressed as an equivalent frequency modulation:

$$v = (\text{amplitude}) \times \sin 2\pi (F_c + \Delta f)t$$

where Δf is obtained from

$$\Delta\omega = 2\pi\Delta f = \frac{d}{dt} \phi(t) = \frac{a_s}{a_c} 2\pi f \cos 2\pi ft$$

$$\Delta f = \Delta f \cos 2\pi ft$$

$$\text{with } \Delta f = \frac{a_s}{a_c} f$$

When we apply this to the discriminator, which is not responsive to amplitude variation, its output is

$$v_{out} = k_d [F_c - F_0 + \Delta f \cos 2\pi ft] \quad [\text{using (A1)}]$$

The mean squared value of the a-c part of the voltage (due to v_s), averaged over a cycle of f , is

$$\overline{v_{os}^2} = k_d^2 \frac{\Delta f^2}{2} = k_d^2 \left(\frac{a_s}{a_c}\right)^2 \frac{f^2}{2} \quad (\text{A3})$$

We now identify v_s as an equivalent sinusoid representing the noise power in a frequency slot df wide centered on $F_c + f$. There are infinitely many such sinusoids. For flat noise on the input side with density N_s watts per Hertz, they have the equal amplitudes and random phases. Taking v_s to be developed across an arbitrary resistive impedance R ,

$$N_s df = \frac{a_s^2}{R}$$

$$a_s^2 = RN_s df$$

The carrier power C is developed across the same load:

$$C = \frac{a_c^2}{R}$$

$$\left(\frac{a_s}{a_c}\right)^2 = \frac{N_s}{C} df \quad (\text{A4})$$

We now obtain the total mean squared noise voltage at the discriminator output contained within a baseband frequency interval f_1 to f_2 by adding up the input noise contributions which translate into this interval. As we sum infinitesimal noise phasors, each adds a frequency modulation to a resultant large phasor which is the carrier, frequency-modulated by all the noise phasors we have already added in. The process begins to fall apart when the accumulated noise amplitude modulation of the resultant phasor becomes large compared with a_c . There has to be an input-side bandlimiting filter to keep the total noise power at least 10 dB below the carrier power. That is about the point where the fluctuations in the carrier-plus-noise envelope get so large compared to the mean that their effects no longer average out in the instantaneous frequency. In fact, at moments when the

instantaneous envelope amplitude is small, the quadrature components of noise can carry the phase of the resultant phasor through extraneous complete revolutions. These phase steps correspond to near impulse changes in frequency, producing the "click" noise whose onset defines (somewhat loosely) the threshold C/N in FM systems. We assume we are well above threshold.

At this point we observe that F_c need not be the unmodulated carrier frequency; it can be the instantaneous frequency of the modulated signal. At any moment the noise power which is being translated into a baseband slot df wide centered on f comes from input noise in two slots df wide centered on $F_c - f$ and $F_c + f$. For flat input noise all such slots are equivalent and the effect of varying F_c is not distinguishable. We do have to take the contributions from both slots. Since noise components are noncoherent, we add their powers, doubling the mean squared baseband voltage in the slot at f .

The total mean squared noise voltage at the discriminator output due to components in the interval f_1 to f_2 is the sum of the mean squared voltages due to the components in the infinitesimal slots:

$$\overline{V_{os}^2} = \int_{f_1}^{f_2} 2k_d^2 \frac{f^2}{2} \frac{N_s}{C} df \quad [\text{using (A3) and (A4)}] \quad (\text{A5})$$

For our assumptions to be valid in the practical case of input bandlimiting, f_2 must be small compared to half the IF bandwidth.

Now let the discriminator be followed by a filter with amplitude frequency response $H(f)$. In (A5), weight the integrand by the filter's power transfer response, which is the square of its amplitude response:

$$\overline{V_{os}^2} = k_d^2 \frac{N_s}{C} \int_{f_1}^{f_2} f^2 |H(f)|^2 df \quad (\text{A6})$$

In video work we may let $f_1 = 0$ even if the measurement is actually made with a hum-removing high-pass filter. Because of the factor of the square of frequency in the integral, the low-frequency noise components make virtually no contribution to the output. Let f_2 be some frequency F beyond which $fH(f)$ is negligible.

For flat noise the concept of the "noise bandwidth" of a filter function is familiar. It is the bandwidth of a hypothetical ideal rectangular filter which would admit the same amount of noise power to its output as does a real filter with arbitrary response shape, when flat noise of the same power density is applied to both. It is convenient to apply the same concept to the noise out of the discriminator, which is called "triangular" because the rms noise amplitude in

a narrow slot centered on f is directly proportional to f . If b_n is the noise bandwidth of $H(f)$ with respect to triangular noise and we made the noise power transmitted through the ideal rectangular filter equal to that transmitted through $H(f)$,

$$\int_0^{b_n} f^2 df = \int_0^F f^2 |H(f)|^2 df$$

$$\frac{1}{3} b_n^3 = \int_0^F f^2 |H(f)|^2 df$$

$$b_n = \left[3 \int_0^F f^2 |H(f)|^2 df \right]^{1/3}$$

With this replacement in (A6),

$$\frac{V_{oa}^2}{V_{na}^2} = k_s^2 \frac{N_o b_n^3}{C}$$

So far as the signal is concerned, we assume that $H(f)$ is sufficiently transparent to the signal that it does not change the peak-to-peak signal voltage, which is still given by (A2). Then

$$(S/N)_s = \frac{V_{spp}^2}{V_{na}^2} = \frac{C}{N_o} \frac{12 (\Delta F_s)^2}{b_n^3} \quad (1)$$

$H(f)$ can represent the deemphasis function or the weighting function or both, in combination with a bandlimiting filter, real or ideal. Deemphasis does indeed change the video waveform, but we always assume that the complementary preemphasis is used at the transmitter so that the combination is transparent. In this case ΔF_s is always taken to be the deviation that would be obtained without preemphasis, and the deemphasis function used is gain-scaled to have zero insertion loss at the prescribed crossover frequency.

There is no way in which the integral in (A6) can be performed piecemeal to handle various contributors to $H(f)$ separately. The combination of weighting, deemphasis, etc., can be handled only by integrating the product of their responses.

References.

1. T. M. Straus, "The Relationship between the NCTA, EIA, and CCIR Definitions of Signal-to-Noise Ratio", IEEE Transactions on Broadcasting Vol. BC-20, No. 3, Sept. 1974, pp. 36-41.

2. C. C. L. R. (International Radio Consultative Committee), "Transmission of Sound Broadcasting and Television Signals over Long Distances (CMTT)", XIIIth Plenary Assembly Vo. XII, International Telecommunication Union, Geneva, 1975, pp. 21-41.

3. Network Transmission Committee, NTC Report No. 7, Public Broadcasting Service, June 1975.

4. Electronic Industries Association, "Electrical Performance Standards for Television Relay Facilities", RS-250-A, Feb. 1967.

5. J. M. Barstow and H. N. Christopher, "The Measurement of Random Interference to Monochrome and Color Television Pictures", AIEE Transactions Pt. 1 Vol. 81, Nov. 1962, pp. 313-320.

6. Lenkurt Electric Co. (GTE Lenkurt Inc.), Engineering Considerations for Microwave Communications Systems, San Carlos 1970, p. 70.

7. Bell Tel. Labs, Transmission Systems for Communications Revised 4th Ed., Winston-Salem 1971, p. 704.

8. C. C. L. R., loc. cit., pp. 60-63.

9. Electronic Industries Association, "Electrical Performance Standards for Television Relay Facilities", Standards Proposal No. 1193, Oct. 1975, pp. 31-32.

10. C. C. L. R., loc. cit., pp. 63-99.

11. Ibid., pp. 106-107.

Part II Systems

There are currently a large number of communications satellites for international, domestic/regional, mobile, military, experimental, and other services.

The reprint papers discuss communication satellite systems that are currently in operation or scheduled for operation in the near term. Future or planned systems are discussed in Part VII. The systems are categorized by their usage using the hierarchy shown below.

Operational
 Commercial
 Fixed
 International
 Domestic/Regional
 Mobile
 Broadcast
 Military
 Fixed
 Mobile
 Experimental
 Civilian
 Military

Several systems with multiple functions have been categorized according to their primary function. The systems discussed in this part are shown in the following lists.

Operational Systems: Current and Near Term

Commercial
 Fixed
 International
 INTELSAT
 INTERSPUTNIK (USSR)
 Domestic/Regional
 TELESAT (Canada)
 Western Union (USA)
 RCA SATCOM
 COMSTAR
 SBS
 TDRSS/Advanced WESTAR
 ESA (OTS/ECS)
 Indonesia (Palapa)
 Arabsat

Indian Satellite
 Mobile
 Marisat (Comsat General)
 MAROTS (ESA)

Military
 Fixed
 DSCS
 Skynet
 NATO
 Mobile
 FLTSATCOM

Experimental Systems: Current and Near Term

Civilian
 ATS-6
 Symphonie
 Canadian Technology Satellite
 Japanese Communication Satellite
 Japanese Broadcast Satellite
 SIRIO
 OTS
 Military
 Lincoln Experimental Satellites (LES)

(Systems which obtain their space segment by lease from another system are not included.) The reference section contains one or more articles describing each of these systems. This introduction provides some general background.

INTELSAT

The INTELSAT system is presently composed of over 100 countries and provides global satellite communications services to three ocean regions.

At present, there are over 141 antennas, typically 30-m dishes, that operate in the 4-6 GHz band. There are three operational satellites in the Atlantic plus an operational spare. There is one satellite plus a spare in both the Indian and Pacific Ocean regions. There are a total of about 35 000 half-circuits in use worldwide (with approximately 22 000 in the Atlantic, 9 000 in the Indian, and 4 000 in the Pacific).

The INTELSAT IV satellite series, first launched in 1971, had a capacity of 8 000 half circuits (channels) plus one TV

transponder and a SPADE transponder and was launched on an Atlas/Centaur. The INTELSAT IV-A provides an increased operational capacity of 12 000 channels plus TV and SPADE transponders (in the Atlantic primary) and was first launched in 1975. The INTELSAT V is scheduled for 1980 use in the Atlantic Ocean Region and will have a capacity of almost 25 000 channels. All of these capacities are relative to use in a frequency modulation-frequency division multiple access (FM/FDMA) mode. The increased capacity of INTELSAT V will be obtained through the use of dual polarization frequency reuse in the 4-6 GHz band plus beam isolation reuse in the same band. In addition, an 11-14 GHz capability has been included, with spot beam antenna coverages over North America and Europe in the Atlantic Ocean region. Reprint Paper 2.1 discusses the INTELSAT system in detail as part of a general synopsis of commercial communications satellites. References [1]-[3] discuss other aspects of the INTELSAT system.

DOMESTIC/REGIONAL

Many domestic satellite systems have become operational during the past several years. The first such geosynchronous system was initiated by TELESAT of Canada with the ANIK satellite launched in 1972. This system is composed of more than 80 earth stations and three satellites operating at 4-6 GHz, providing voice, video, and data communication services. The system also incorporates the first operational TDMA link at a transmission rate of 61 Mbit/s. Both heavy-route and thin-route services are provided, and a mix of earth segment equipment exists. Reprint Paper 2.1 and [4] discuss the Telesat system.

The U.S.S.R. has had, since the mid-1960's, an operational nonsynchronous system employing the Molniya satellites. These satellites are in elliptical orbit and use tracking earth-station antennas. In late 1975, the U.S.S.R. launched the first of the STATIONAR series of synchronous satellites to be used for domestic service using the 4-6 GHz band. A total of ten STATIONAR orbital slots are planned, seven of which would be used for global coverage (see [5]).

In the U.S. there are presently three operational systems—Western Union's WESTAR, RCA's SATCOM, and COMSAT General COMSTAR which is leased to AT&T and is used by both AT&T and GTE satellite earth stations. Both WESTAR and COMSTAR are spin-stabilized satellites, and all three operate in the 4-6 GHz band. The RCA SATCOM satellite is three-axis stabilized and was the first satellite to be launched on the Thor-Delta 3914 vehicle. In addition, the RCA and COMSTAR satellites use dual-linear polarization for frequency reuse, while WESTAR operates on a single polarization. Reprint Paper 2.1 and [6]-[8] discuss these systems.

Reprint Paper 2.2. describes the SBS system. This is an innovative system which will provide integrated voice, data, and image services using digital transmission at 12 and 14 GHz between 5- and 7-m customer premise earth stations. The use of a flexible TDMA allows efficient use of

the satellite capacity.

Algeria, the Arab States, Brazil, Colombia, India, Indonesia, Iran, Japan, Malaysia, and Nigeria are also operating, developing, or seriously planning their own domestic or regional systems. The Algerian, Brazilian, Malaysian, and Nigerian systems currently use leased transponders on the INTELSAT satellites. Norway is also using leased INTELSAT capacity to provide service to the North Sea oil rigs. References [9]-[11] discuss some of these systems.

MOBILE

The MARISAT satellites, operated by COMSAT General, provide services to the U.S. Navy in the Atlantic, Pacific, and Indian Ocean regions and commercial voice and teletype communications in the Atlantic and Pacific Ocean regions [12]. The commercial portion of MARISAT is a C-band (4-6 GHz) earth-station satellite link crossed to an L-band (1.5-1.6 GHz) satellite/ship link. The ship terminals use 1.3-m tracking antennas. The military portion of the satellite uses frequencies in the lower UHF band.

The European Space Agency (ESA) is planning a maritime satellite called MAROTS [13]. An aeronautical satellite system, AEROSAT, had been planned for use over the Atlantic Ocean, but the program has been cancelled [14]. Several conference proceedings [15]-[16] are useful references on mobile communications.

MILITARY SYSTEMS

Military satellite communications systems have demonstrated the unique capabilities that they can provide in both the strategic and tactical environments and are currently an important part of the overall military communications system.

These systems are designed to satisfy the unique and vital requirements of the military as well as to ensure the existence of a communication capability in crisis situations. The military X-band (7-8 GHz) systems are primarily used for strategic communications including intelligence, trunking, extension and restoration of terrestrial-switched systems, and in support of strategic command and control requirements. They provide some communication to major Navy ships and potentially can provide communication to command aircraft. The UHF systems primarily provide tactical command and control communication for mobile platforms, including ships, aircraft, and ground vehicles.

The military systems must satisfy certain requirements which tend to make them more expensive and require technologically advanced designs.

The system must be able to provide secure communication to a large mix of earth terminal types with rapidly changing requirements, even in the advent of electronic warfare, or, in some cases, physical attack. Satisfying these requirements implies a need for such features as a secure and protected command and telemetry system, narrow-beam satellite antennas, satellite antennas with nulling capabilities, and an essentially real-time control capability.

By the early 1980's the U.S. strategic system, the Defense Satellite Communications System (DSCS), will be composed of DSCS II and DSCS III spacecraft. Reprint [17]-[21] describes the DSCS-III satellite. References [17]-[21] discuss the DSCS system. The NATO system will be composed of NATO III spacecraft [22]-[23].

The U.S. UHF system consists of the leased UHF position of three MARISAT satellites and the FLTSATCOM spacecraft [24]. In the early 1980's, it will be augmented by a set of leased satellites.

The Lincoln Experimental Satellites (LES) have been used to develop and demonstrate many of the advanced technologies and system concepts. References [25]-[26] discuss the latest in the series, LES 8 and 9. Reprint Paper 1.6.7.1 discusses the intersatellite link on the LES 8/9.

EXPERIMENTAL

A number of satellites have been orbited in the last ten years for the purpose of communication satellite application and technology evaluation. Of particular interest are those systems which are pioneering the technology and operational experiments for broadcast satellite applications and systems which are major precursors to potential operational satellite-based telecommunication systems. The first class includes ATS-6, the Canadian Technology Satellite (CTS), the Japanese Broadcast Satellite Experiment (BSE), and the Russian Stationar satellites. The second class includes the ESA Orbital Test Satellite (OTS), the French-German Symphonie satellite, the Italian SIRIO satellite and the Japanese Experimental Test Satellite (ETS-2), Experimental Communications Satellite (ECS), and medium capacity Communications Satellite (CS). Both classes of systems are not only important technology experiments, particularly in the areas of higher satellite EIRP and/or the use of higher frequency bands, but also involve significant applications oriented experiments and demonstrations.

Reprint Paper 2.4 discusses the significance of the ATS-6. References [27]-[28] describe the ATS-6 satellite. The CTS system is described in [29]-[30].

The Symphonie satellite is being used for numerous technical and operational experiments as described in [31]. OTS is a three-axis stabilized satellite developed by the European Space Agency [32]-[33] which operates in the 11-14 GHz band with polarization frequency reuse. It is designed as a precursor to the planned operational European Communications Satellite (ECS) system [34]-[35]. The ECS System is expected to provide intra-European international telephony service, exchange of TV programs among the members of the European Broadcasting Union, and new services such as high-speed data, TV broadcasting, teleconferencing, communications to North Sea oil rigs, and computer communications. The Italian SIRIO satellite which was launched in 1977 is being used for various propagation and communications experiments [36].

The Japanese ETS-2 satellite, which contains an S-band transponder, has the primary mission of enabling Japan's

National Space Development Agency (NASDA) to develop and test its ability to launch and control a spacecraft in synchronous orbit. It was launched using an N-rocket in 1977. It also contains a propagation experiment transmitter which can provide S-band (1.7 GHz), X-band (11 GHz), and Ka-band (34 GHz) coherent signals.

The ECS satellite will be launched on an N-rocket. It will contain C-band and K-band (34.8-GHz uplink and 31.6-GHz downlink) transponders for digital data, wideband FM color television transmission (20-40 MHz), and K-band propagation experiments.

The CS satellite is the first commercial satellite operating in the 30-20 GHz region. The satellite contains six 200-MHz transponders in the 30-20 GHz band and two 200-MHz transponders in the 6-4 GHz band. It is being used with a variety of earth stations ranging in size from 3 to 13 m. References [37]-[41] describe the various Japanese satellite programs.

REFERENCES

- [1] "A decade of Intelsat," *J. British Interplanetary Society*, vol. 28, no. 7, Jul. 1975.
- [2] B. Edelson, H. William Wood, and C. J. Reber, "Cost effectiveness in global satellite communications," *IEEE Communications Society Magazine*, Jan. 1977.
- [3] B. I. Edelson, R. Strauss, and P. L. Bargellini, "Intelsat system reliability," *Acta Astronautica*, vol. 2, nos. 7-8, Jul.-Aug. 1975.
- [4] D. G. Thorpe, "Evolution of the Telesat Canada System into the mid-1980's," in *Satellite Communications: Future Systems, from Progress in Astronautics and Astronautics*, vol. 54, David Jarrett, Volume Ed., Martin Summerfield, Series Ed., New York: AIAA 1977.
- [5] K. Johnsen, "Soviets plan seven-satellite global system," *Aviation Week & Space Technology*, Dec. 15, 1975.
- [6] D. J. Lee, "System performance of America's first domestic communications satellite—WESTAR," *Proc. of EASCON 74*, pp. 386-393.
- [7] J. Christopher and D. Greenspan, "RCA Satcom communication system," *EASCON '77*, Washington, DC, Sept. 26-28, 1977.
- [8] M. Abutaleb, M. C. Kim, K. F. Manning, J. F. Phiel, Jr., and L. H. Westerlund, "The COMSTAR satellite system," *COMSAT Technical Review*, vol. 7, no. 1, 1977.
- [9] J. S. Tengker, "Indonesian domestic satellite system," *EASCON 76*, Sept. 1976, pp. 11-A-11-U.
- [10] M. Abdallah, "The Arab satellite," *Telecommunication J.*, vol. 44-IX, Sept. 1977, p. 422.
- [11] A. Bairi and J. Leonhard, "A domestic satellite communications system for Algeria," *Int. Communications Conf.*, San Francisco, CA, June 1975.
- [12] D. W. Lipke, D. W. Swearingen, J. F. Parker, E. E. Steinbrecher, T. O. Calvit, and H. Dodel, "MARISAT—A maritime satellite communication system," *COMSAT Technical Review*, vol. 7, no. 2, pp. 351-392, 1977.
- [13] O. J. Haga and J. A. Vandenkerckhov, "MAROTS: A satellite for maritime communication," *IAF XXVIII Congress*, Prague, Sept. 25-Oct. 1, 1977.
- [14] E. F. Binz, "A satellite concept for Aerosat," *AIAA Paper 76-259*, *AIAA/CASI 6th Communications Satellite Systems Conf.*, Apr. 1976.
- [15] "Satellite systems for mobile communications," *IEEE Conf. Publication No. 95*, Mar. 1973.
- [16] International Conference on Maritime and Aeronautical Satellite Communication and Navigation, *Conf. Proc.*, London, Mar. 1978.
- [17] G. E. LaVeau, "The defense satellite communications system," *AIAA Paper No. 74-457*, Los Angeles, Apr. 1974.
- [18] F. E. Bond and W. H. Curry, Jr., "The evolution of military satellite communications systems," *Signal*, Mar. 1976, pp. 39-44.
- [19] W. H. Curry, Jr., "The military satellite communications systems architecture," *Paper 76-252*, *1976 AIAA Satellite Communications Conf.*, Apr. 1976.

- [20] J. H. Babcock, "Architecture and management of DOD satellite communications programs," *EASCON '77*.
- [21] H. Wynne and D. E. Kendall, "Defense satellite communications system in the 1980's," *WESCON*.
- [22] H. A. Kissinger, "NATO satellite communications: Past, present and future," *Signal*, Mar. 1976, pp. 53-57.
- [23] E. T. Bobak and R. G. Clabaugh, "NATO phase III satellite design," *EASCON '77*, Washington, DC, Sept. 26-27, 1977.
- [24a] N. L. Wardle, "U.S. Navy fleet satellite communications," *AIAA Paper, No. 74-458*, Los Angeles, Apr. 1974.
- [24b] F. S. McCartney and E. K. Heist, "FLTSATCOM program review: Requirements, design, and performance," *WESCON*, Los Angeles, Sept. 1978, pp. 442-452.
- [25] F. J. Solman, C. D. Bergland, R. W. Chick, and B. J. Clifton, "The K_a-band systems of the Lincoln Experimental Satellites LES-8 and LES-9," *Proc. 7th AIAA Communications Satellite Systems Conf.*, San Diego, Apr. 24-27, 1978, pp. 208-215.
- [26] L. J. Collins, L. R. Jones, D. R. McElroy, D. A. Siegel, W. W. Ward, and D. K. Willim, "LES-8/9 communications system test results," *Proc. 7th AIAA Communications Satellite Systems Conf.*, San Diego, Apr. 24-27, 1978, pp. 471-478.
- [27] D. B. Dobson, Ed., *Special Issue on IEEE Trans. on Aerospace and Electronic Systems on ATS-6 Satellite*, vol. AES-11, no. 6, Nov. 1975.
- [28] W. M. Redisch, "ATS-6 Description," *Proc. of the IEEE International Conf. on Communications*, Jun. 16-18, 1975, pp. 18-1-18-5.
- [29] C. A. Franklin and E. H. Davison, "A high-power communications technology satellite for the 12 and 14 GHz bands," *AIAA Fourth Communications Satellite Systems Conf.*, Washington, DC, Apr. 24-26, 1972.
- [30] P. L. Donoughe, "United States societal experiments via the communications technology satellite," *Proc. of the IEEE Int. Conf. on Communications*, Jun. 14-16, 1976, pp. 1-17-1-22.
- [31] G. Moesi and J. Muller, "In-orbit performance and experimental utilization of the symphonic satellites," *Paper 76-306, 1976 AIAA Satellite Communications Conf.*, Montreal, Apr. 1976.
- [32] R. C. Collette and B. Stockwell, "The OTS Project, basis of future European space communications systems," *AIAA 5th Communications Satellite Systems Conf.*, Los Angeles, Apr. 22-24, 1974.
- [33] S. Tirro and A. Bayliss, "The utilization programme of the orbital test satellite," *Paper 76-247, 1976 AIAA Satellite Communications Conf.*, Montreal, Apr. 1976.
- [34] R. C. Collette, "The European communications satellite programme and the orbital test satellite," *Journal of the British Interplanetary Society*, vol. 29, 1976, pp. 335-353.
- [35] P. Bartholome, "The European communications satellite system—A review of current and planned activities," *Paper 76-243, 1976 AIAA Satellite Communications Conference*, Montreal, Apr. 1976.
- [36] F. Carassa, L. A. Ciavoli-Cortelli, and S. Tirro, "The SIRIO-SHF Experiments: First in-orbit measurements, results and possibilities of experimentation," *IAF XXVIII Congress*, Prague, Sept. 25-Oct. 1, 1977.
- [37] T. Ishida, N. Fugono, J. Tabata, and M. Ohara, "Program of Experimental Communication Satellite (ECS) of Japan," *Paper 78-614, 1976 AIAA Satellite Communications Conf.*, Montreal, Apr. 1976.
- [38] H. Kaneda, K. Tsukamoto, and H. Fuketa, "Experiments in the Japanese CS Program," *Paper 78-616, 1976 AIAA Satellite Communications Conf.*, Montreal, Apr. 1976.
- [39] T. Ohtake, H. Reichert, and L. T. Seaman, "Japanese broadcast satellite," *Microwave Journal*, Sept. 1977.
- [40] H. S. Braham, "Spacecraft for broadcast systems," *EASCON '77*, Washington, DC, Sept. 26-28, 1977.
- [41] H. Kaneda, K. Tsukamoto, and O. Ogawa, "Experiments with the Japanese medium-scale broadcast satellite," *Paper 78-573, 1976 AIAA Satellite Communications Conf.*, Montreal, Apr. 1976.

2.1
A SYNOPSIS OF COMMERCIAL SATELLITE COMMUNICATIONS SYSTEMS*

P. L. Bargellini, Senior Scientist
COMSAT Laboratories
Clarksburg, Maryland 20734

INTRODUCTION

With their impact upon people's lives and exchanges among nations, communications satellites, which constitute one of the outstanding fallouts of the space program, have totally altered the patterns of world communications. Communications by satellite, having evolved from science fiction through scientific and engineering developments to trials and operations, is now a thriving business. Satellite systems inter-act effectively with terrestrial networks; their second decade of operational service began three years ago, and substantial growth is foreseeable in the future.

Developments in the commercial field can be best projected by distinguishing three separate categories of satellite systems: the international INTELSAT system, domestic (U.S. and non-U.S.) systems, and mobile systems. With respect to the first category, the INTELSAT system today provides routine reliable worldwide communications. In the second category, satellite systems in Canada, the Soviet Union, Indonesia, and the United States provide domestic communications for telephone, television, facsimile, and data traffic. Finally, in the case of mobile services, communications via satellite have been extended to ships at sea with the MARISAT system.

This paper reviews the origins of satellite communications, surveys their technological and operational progress, and examines future trends.

HISTORICAL BACKGROUND

Satellite communications combines two distinct technologies, rocketry and microwave engineering, which had greatly advanced during World War II. Their combination, intended to provide new means of communications, was proposed shortly after the end of the War; early experiments occurred about 15 years later.

In 1945, Arthur C. Clarke conceived satellites in geosynchronous orbit providing global telecommunications. Clarke showed that three geosynchronous satellites, powered by solar energy converted into electricity by silicon cells, could provide worldwide communications "for all possible types of service with unrestricted use of a frequency band at least 1000 MHz wide (providing), with the use of beams, an almost unlimited number of channels."¹

The translation of Clarke's concept into reality required adequate rockets for launching satellites and suitable onboard electronic devices. In the field of rocketry, the pioneering work of Constantin Tsiolkowsky, Robert Goddard, Herman Oberth, and Wernher Von Braun led through the V-1's and V-2's of World War II to the first Sputnik, launched by the U.S.S.R. in October 1957. In communications, electronic devices operating at ever increasing frequencies and a better understanding of radio wave propagation phenomena were major causes of progress. Curiously enough, however, until the late 1940's electrical communications systems had developed without a clear understanding of the commodity (information) which was being handled. In 1948, long after practical communications systems had been implemented, Statistical Communication Theory,

*This paper is based on work performed at COMSAT Laboratories.

also known as Information Theory, was developed. This theory and its many extensions focus on the fundamental relationships among information transmission rate, bandwidth, signal and noise power, transmission impairments, and attenuation.²

Communications satellite systems benefited from all this knowledge, and as soon as rocket engineering was capable of safely injecting reliable electronic packages into orbit, success was ensured. Most importantly, a substantial increase in communications capacity and network flexibility with respect to previously available wire and wireless systems was achieved.

Arthur Clarke's concept went unnoticed by communications engineers for several years. In 1954, J. R. Pierce of Bell Telephone Laboratories independently studied the fundamentals of radio relaying via artificial satellites, and two years before Sputnik, prepared concrete technical proposals for satellite communications.³ Passive satellites had the important advantages of simplicity and potentially unlimited multiple access. However, the inverse distance square law applicable to active satellites gives them a substantial advantage over passive satellites, to which the inverse distance fourth power law applies. Thus, although early experiments were performed with reflecting balloons, all operating systems have used active satellites.

The stage was set for satellite communications when the first commercial satellite, Early Bird, was orbited in 1965. With Early Bird, the status of transoceanic communications was drastically altered as 240 voice circuits became available, and high-quality transatlantic TV was possible for the first time.

SERVICES AND INSTITUTIONAL ARRANGEMENTS

The combined efforts of governments and industry were required to promote space exploration leading to satellite communications. In the United States, the Communications Satellite Act, enacted by the 87th Congress in August 1962, was signed by President John F. Kennedy on 31 August 1962. The Act declared it to be the policy of the United States "to establish, in conjunction and in cooperation with other countries, as expeditiously as practicable a commercial communications satellite system, as part of an improved global communications network, which will be responsive to public needs and national objectives, which will serve the communications needs of the United States and other countries, and which will contribute to world peace and understanding."

The Communications Satellite Corporation (COMSAT), incorporated in February 1963, led the development program for the global satellite system and its financing. In 1964, 11 participant nations entered into a unique international partnership originally known as the International Telecommunications Satellite Consortium (INTELSAT), and designated COMSAT as its manager.

Since its inception, INTELSAT has operated under two sets of agreements, referred to as interim and definitive. On 12 February 1973, INTELSAT, whose

membership had grown to 87, became the International Telecommunications Satellite Organization, with the definitive agreements becoming effective.

While the space segment, consisting of the satellites and the facilities required to support their operation, is owned and operated by INTELSAT, the earth segment, which comprises the earth stations in various countries, is owned by designated telecommunications entities in each country.

The expansion of the INTELSAT system, which continued with great vigor and has been documented in the literature,^{4,5} will be illustrated in some detail in a later section.

Although in recent years domestic services have been provided by INTELSAT to numerous countries (at present 13 countries lease 12 transponders from INTELSAT and some 70 earth stations are in use for this purpose), it became clear in the late sixties that satellite communications for internal (domestic) services would be highly attractive to countries characterized by vast territory or geographical singularities which would make difficult and costly the deployment of earth-based communications systems.

The U.S.S.R. initiated domestic satellite communications in 1965 with nongeosynchronous Molniya satellites placed in highly elliptical orbits inclined by 65°. Their capabilities have been increased and the orbits have been replenished to accommodate the relatively short lifetime of these spacecraft. More recently the U.S.S.R. has also placed several communications and broadcast satellites in geosynchronous orbit (Statsionar, Raduga, Ekran, etc.). In November, 1972, Canada launched the first geostationary satellite for domestic communications. The Canadian system is in its sixth year of operation; a second generation of spacecraft is under construction, and a third generation is planned.⁶ In November 1975, Indonesia inaugurated its own domestic satellites.⁷ Domestic satellites have permitted the establishment of new, highly reliable, high-capacity communications links where almost none existed previously.

The different situation in the U.S.,⁸ due to existing ground-based communications networks, has led to the establishment of four separate, partly competing systems, and an additional innovative system is currently being developed.

Satellites are obviously ideal for establishing links with mobile terminals. In 1976, almost a decade of efforts directed toward the development of a satellite system to serve mobile maritime users led to the implementation of the MARISAT system.⁹

The extension of communications satellites to aeronautical services, TV distribution, educational and public services and also direct broadcasting to individual homes has been the object of numerous studies. All the above mentioned areas show considerable promise; yet difficult institutional and financial problems will have to be resolved before operational status is achieved.¹⁰

CHOICE OF THE ORBIT

Orbital height and inclination are fundamental parameters of satellite systems.¹¹ From Kepler's Laws, the orbital period is

$$P = \frac{2\pi a^{3/2}}{\mu}$$

where a is the semimajor axis of the ellipse, and μ is the gravitational constant \times earth mass = 3.99×10^{14} m³/s². As only modest payloads (~100 kg) could be placed in low- or medium-altitude orbits (<10,000 km) by early rockets, these orbits were used for experimental satellites. Satellites in low orbits pass rapidly overhead and require tracking. Continuous communications between points on the earth's surface would thus require traffic handover as a satellite sets beyond the horizon while another rises to take its place and many satellites to ensure continuous coverage. In spite of these difficulties, systems were proposed with as many as 50 spacecraft in medium-altitude orbits to serve the Atlantic Ocean region. Early experiments with single spacecraft (TELSTAR, 1962-1963, and RELAY, 1962-1964) proved the feasibility of active satellites.

Increasing the orbital altitude to 35,863 km, i.e., about six times the earth's radius, increases the period to a sidereal day (23 hr, 56 min). A synchronous satellite above a fixed spot, subtends an angle of about 18°, and can provide coverage of about four-tenths of the earth's surface. Additional advantages of the "geostationary" orbit are zero Doppler, infrequent thermal stress cycles, moderate energy storage requirements for eclipse operation, mild radiation environment above the Van Allen belts, and minor perturbations by the earth's magnetic field.

Yet the difficulties of achieving operation in geostationary orbit were considerable. The Thor-Delta vehicle, which had been used for launching the TELSTAR (AT&T, 1962-1963) and RELAY (RCA-NASA, 1962-1964) satellites, was inadequate to inject a payload of around 80 kg directly into geostationary orbit from Cape Kennedy (28° north latitude). A brilliant solution, consisting of first injecting the payload in a highly elliptical orbit with apogee at synchronous altitude, was eventually adopted.¹² An added rocket, weighing about one-half of the payload in transfer orbit and fired at apogee, allowed circularization of the orbit. Auxiliary thrusters were used to change the orbital plane, thus achieving zero inclination. Such a mission was regarded as highly complicated, given the state-of-the-art of space technology at the time it was first proposed. The first experimental geosynchronous satellite, SYNCOM I (February 1963), failed to attain its orbit; the second and third launches of SYNCOM II (July 1963) and SYNCOM III (August 1964) were successful. These satellites were developed for NASA by the Hughes Aircraft Co.

A geostationary satellite must be kept in position as solar and lunar gravitational forces and the nonsphericity of the earth cause orbital perturbations. Solar radiation pressure is an additional nongravitational perturbation. Stationkeeping is required to counteract these forces, corrections being obtained by activating onboard thrusters upon command from the earth. Ideally, longitudinal drift and orbit inclination can be controlled independently, but in practice some interaction is encountered. Usually drift is allowed to build up to some set value beyond which corrective maneuvers are effected. Information from earth, sun, and star sensors provide the inputs for correction maneuvers.

In addition to orbital positioning, attitude control is necessary to point the satellite's directional antennas toward the earth. A common method of attitude control consists of spinning the satellite body for gyroscopic stiffness. Despinning the communications antenna permits beam pointing accuracy of

the order of about one-tenth of a degree. This simple, reliable method eases the problem of thermal control of the structure, but also results in only partial utilization of the total area of the solar cell panels, limiting the amount of electrical power available.

Early Bird (INTELSAT I) was an "experimental satellite with operational capabilities" which provided answers to questions related to the applicability of geostationary satellites within the existing global terrestrial telephone network.¹³ Early Bird remained in operational commercial service for more than four years.

THE COMMUNICATIONS PROBLEMS

Satellite communications involve at least two cascaded links: the up-link from an earth station to the active repeater in orbit, and the down-link from the satellite to another earth station. The two channels in opposite directions constitute a full circuit. A satellite in geosynchronous orbit which sees about four-tenths of the earth's surface can, in principle, link any pair of stations separated by great circle distances up to 17,000 km. It is this capability of multiple access which makes satellites a truly unique tool for communications.

For a stations "visible" from a satellite, the number of potentially available communications circuits is

$$n = \frac{m(m-1)}{2} \quad (2)$$

Clearly, the n-port network topology of the satellite system offers conspicuous advantages vis-a-vis the inflexibility of 2-port networks such as cable and land circuits.

For a single link, the rate of information transmission relates to certain fundamental parameters through the equation

$$R = \frac{B P_t G_t A_r}{4\pi r^2 \beta N} = \frac{B C}{\beta N} \quad (3)$$

where

- R = information rate (bit/s)
- r = link distance (m)
- B = bandwidth (Hz)
- P_t = transmitter power (W)
- G_t = transmitting antenna gain
- A_r = receiving antenna area (m²)
- β = communications efficiency = $\frac{\text{energy per bit}}{\text{noise power density}}$
- C = carrier power (W)
- N = noise power (W)

The upper bound for R is the Shannon channel capacity:

$$R \leq B \log_2 \left(1 + \frac{S}{N} \right) \quad (4)$$

When B is allowed to go to infinity, the signal-to-noise ratio goes to zero and the communications efficiency, β, assumes the asymptotic minimum value log_e2 = 0.693. The actual value of β greater than the above-mentioned minimum depends upon the modulation-demodulation scheme. Equation (3) indicates that communications capacity is proportional to bandwidth and power when other quantities are fixed. Optimum operating frequencies and bandwidth defined, in principle, on the basis of minimum noise power density and favorable propagation conditions depend in practice on spectrum availability in terms of international and

regional agreements. Power, easily available on the ground, is limited by spacecraft mass and hence launch vehicle capability.

Since onboard transponders have, until now, been operated as frequency translators between the up- and down-links, two cascaded links are considered. The system transmission rate is obtained by introducing into equation (3) the overall carrier-to-noise ratio, which is equal in analog systems to the inverse of the sum of the inverses of the carrier-to-noise ratios in the up- and down-links [(C/N)_u and (C/N)_d, respectively], i.e.,

$$R = \frac{B}{\beta} \frac{(C/N)_u (C/N)_d}{(C/N)_u + (C/N)_d} \quad (5)$$

Among the modulation schemes capable of trading signal-to-noise (S/N) ratio for bandwidth, frequency modulation (FM) has prevailed because of its effectiveness, simplicity, and adaptability to the interfacing of satellite and ground communications systems. Frequency modulation, combined with frequency-division multiplexing (FDM) of voice channels at baseband and frequency-domain multiple access (FDMA) for several RF transmissions through the satellite, constitutes the transmission scheme known as FDM/FM/FDMA.*

Unfortunately, the situation is complicated by nonlinearities, especially in traveling wave tube amplifiers (TWTAs), which cause undesirable modulation conversion effects (AM/AM and AM/PM) in both the satellite repeaters and the transmitting earth stations. Ultimately, the maximum information transmission rate—in practice, the number of telephone circuits a satellite can handle—is dictated by the overall carrier-to-noise ratio, C/N_{tot}, whose inverse equals the sum of the inverse carrier-to-noise ratios arising in the up-link, down-link, and in the intermodulation processes:

$$\frac{1}{C/N_{tot}} = \frac{1}{C/N_{up-link}} + \frac{1}{C/N_{down-link}} + \frac{1}{C/N_{im}} \quad (6)$$

Other impairments arise from earth RF out-of-band emission, cochannel interference due to imperfect beam isolation, transponder group-delay and dual path distortion, and adjacent transponder interference. Finally, in the case of frequency reuse through orthogonal polarizations, another kind of interference appears in the form of cross coupling due to rain depolarization effects (amplitude and phase). Clearly, transmission system planning requires careful analysis of several interactive factors.

With FDM/FM/FDMA, the intermodulation noise contribution can be reduced by backing off the TWTAs until a maximum value for C/N_{tot} is achieved in equation (6). In general, the choice of a specific method of multiple access, or a combination of the methods of multiple access with appropriate forms of modulation and multiplexing, yields solutions which are ultimately evaluated in terms of the number of channels which can be provided.

With communications capacity proportional to transmitter power, and power in turn related to spacecraft mass and size, since the communications subsystem

*A notable exception is the phase shift keyed (PSK) FDMA single-channel-per-carrier (SCPC) access on demand transmission system (SPADE) introduced in INTELSAT in 1969 and presently used by more than 30 countries.

of a satellite is the useful payload, it is important to minimize the mass of all noncommunications subsystems. In the apportionment of mass among the different subsystems (communications, structure, power, positioning and orientation, and TT&C), communications satellites of different types have been investigated.¹⁴ Trends have thus been identified which reveal that the use of advanced technologies would greatly increase communications capacity for a given total satellite mass. Although some of these concepts have been verified in experimental programs, the first decade of satellite communications has chiefly evolved around the gradual growth from the technology introduced in the SYNCOM and Early Bird satellites. In this sense, communications capacity has increased essentially in terms of larger and more powerful satellites. The variety of launch vehicle combinations and their capabilities are shown in Figure 1 for conventional disposable rockets.

above the equator. This choice allows continuous coverage, with tracking by earth stations necessary to maintain the antenna beams pointed at the satellite in the presence of very small drift angles. All of the satellites used so far are spin-stabilized; that is, they maintain their orientation in space through rotation of the satellite body along an axis parallel to the earth's axis. Silicon solar cells mounted on the spinning body convert solar energy into electrical energy and nickel-cadmium batteries provide energy during eclipses.

The satellites receive on frequencies in the 6-GHz band and transmit on frequencies in the 4-GHz band. Thus, the repeaters have all been frequency translators with wideband receivers and, usually, channelized transmitters. Tunnel diodes have been used in the front end and traveling wave tubes (TWTs) as final amplifiers delivering a few watts of RF power.

The evolution of the INTELSAT space segment is illustrated in Figures 2 and 3.

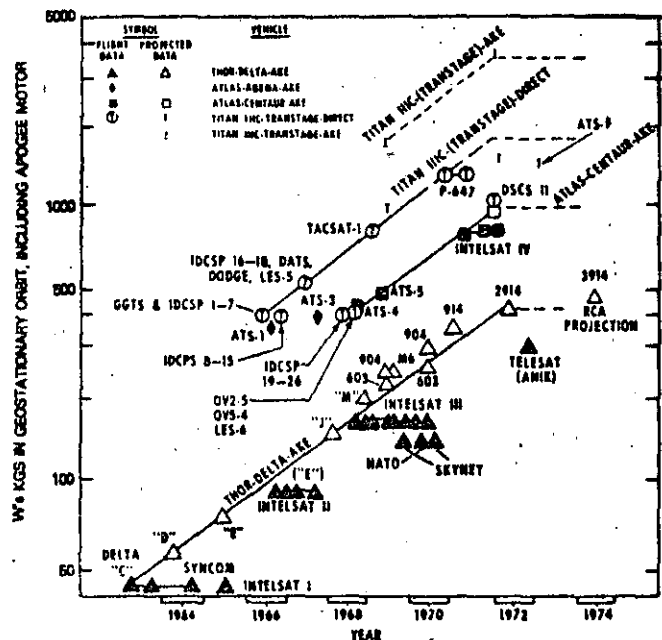


Figure 1. Launch Vehicle Evolution

In spite of the many potential launchers, from small rockets to the huge SATURN V vehicle, the choice of a practical means of placing communications satellites in geosynchronous orbit is limited, in the U.S.A., to the Thor, Atlas, and Titan rockets in combination with specific upper stages. Important factors are also the availability of launch facilities at suitable geographical locations, the life of a given program, its reliability record, and naturally, the cost of the vehicle.

In recent years NASA's efforts have been directed toward the construction of reusable vehicles which will take off as rockets and land as planes. The impact of this Space Transportation System, in combination with the upper stages required to inject payloads in geosynchronous orbit on future communications satellites, will certainly be conspicuous.¹⁵⁻¹⁷

THE INTELSAT SYSTEM

The INTELSAT global system, the first commercial system in operation (1965), is today by far the largest and most extensive. All INTELSAT satellites have operated in synchronous equatorial orbits: 35,700 km

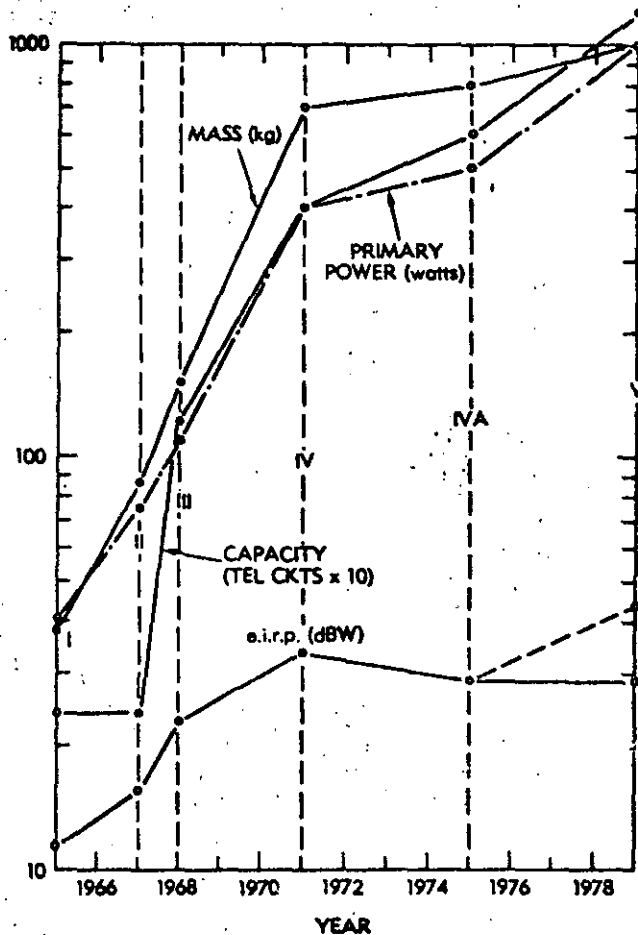


Figure 2. Evolution of INTELSAT Space Segment

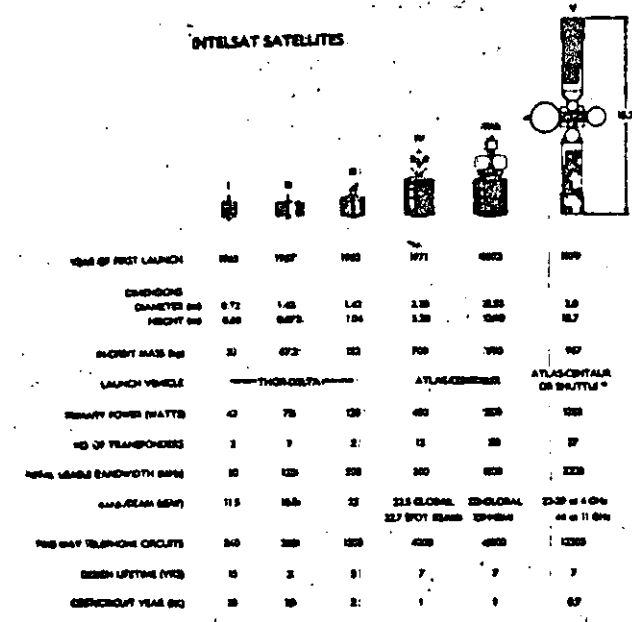
As the effectiveness of a communications satellite depends upon its capacity, which in turn is related to radiated power and bandwidth, and upon lifetime in orbit, the technology developed during the 1965-75 decade by INTELSAT resulted in improvements in all three areas:

- a. **Power.** More powerful launch vehicles allowed greater mass in orbit, thus providing a greater area for solar cells and more electrical power for radio transmitters.
- b. **Bandwidth.** Increased power and more sophisticated transponder design permitted more efficient use of the allocated bandwidth, and eventually its reuse.
- c. **Lifetime.** Improved components, devices, and design, and more effective quality assurance techniques improved satellite reliability and operating lifetime.

antenna always pointed toward the earth, providing a so-called "global beam" which covered all of the earth visible from a given position of the synchronous orbit.

The first INTELSAT IV satellite was launched in January 1971. Built by Hughes, and weighing 720 kg in orbit, these satellites are still in use. The major advance of INTELSAT IV over its predecessors was the use of "spot-beam" transmit antennas covering only a small portion of the visible earth, in this case a beam angle of about 4.5°. The resulting concentration of radiated energy contributed to the increased capacity. The INTELSAT IV satellites are rated at about 4,000 circuits or greater, depending on the number of transponders connected to spot beams and the multiple-access system in use. The INTELSAT IV electrical power subsystem provides about 470 W generated by some 45,000 solar cells, and includes nickel-cadmium batteries used during solar eclipse.

INTELSAT SATELLITES



INTELSAT IV was the first communications satellite to be bandwidth- rather than power-limited.¹⁸ The communications subsystem is channelized into 12 transponders of 36-MHz bandwidth. All transponders receive from a global-beam antenna. Both global- and spot-beam transmit antennas provide respectively about 180 and 2,500 W of equivalent radiated power (22.5- and 34-dBW e.i.r.p.).

Improvements of the INTELSAT IV configuration resulted in the INTELSAT IV-A satellites, again built by the Hughes Aircraft Company. The first of these satellites entered service in 1975 in the Atlantic region to meet that area's high level of traffic requirements.

From 1976 to 1977, three other INTELSAT IV-A satellites entered service, two in the Atlantic and one in the Indian Ocean region. Frequency reuse techniques, through spatial separation, allow simultaneous use of the same portion of the spectrum in two separated areas; e.g., in the Atlantic region, one shaped beam will cover Europe and Africa, and the other will cover North and South America. A global beam is also available and 20 transponders, connected in various combinations, provide global, eastern, or western receive or transmit beams. With approximately the same weight and power as INTELSAT IV and using the same 6/4-GHz frequency band, the INTELSAT IV-A satellite has 50 percent greater capacity, i.e., about 6,000 circuits.

The INTELSAT V satellites,¹⁹ the first of which is expected to become operational by late 1979 or early 1980, will differ from their predecessors as follows:

- a. body stabilization,
- b. fourfold frequency reuse by beam separation and cross polarization of the 500-MHz available bandwidth at 4/6 GHz, and
- c. use of the 11/14-GHz band with twofold frequency reuse of the available 500-MHz bandwidth via beam separation.

Table 1 gives the major characteristics of this series of satellites. The configuration chosen for INTELSAT V, shown in detail in Figure 4, departs from that of the preceding INTELSAT satellites. Increased communications capacity will be achieved by the following means:

- a. higher power (prime, RF, and e.i.r.p.);
- b. more efficient bandwidth utilization;

Figure 3. INTELSAT Spacecraft Characteristics

Early Bird, built by the Hughes Aircraft Company, was launched in April 1965. It weighed only 38 kg in orbit and had a total effective radiated power of 10 W in each of two transponders, using only 50 MHz of bandwidth. Its limited power output required that the spinning antenna radiation pattern be "squinted" to cover North America and Europe. Its potential capacity of 240 two-way telephone circuits allowed linking of only two earth stations at a time; i.e., multiple access was not available, nor was it possible to carry television and telephone simultaneously.

A second series of commercial satellites was developed to support the manned spaceflight operations of NASA. Reliable communications were urgently needed to connect a worldwide network of tracking stations for Project Apollo, some on islands and others on ships at sea. The Hughes-built INTELSAT II satellites were larger than Early Bird, having more power and bandwidth, and thus were able to provide coverage of a wider area of the earth. An important innovation in INTELSAT II was multiple-access capability; many pairs of earth stations could be connected through the satellites, each transponder carrying several radio frequency carriers simultaneously. The first INTELSAT II satellite entered service in January 1967.

The larger INTELSAT III series, built by TRW, was introduced in late 1968. By 1969, three of these satellites made possible the realization of a true global communications system. Each INTELSAT III had a nominal capacity of 1,200 telephone circuits. This increase was achieved by using a mechanically despun

- c. addition of the 11/14-GHz bands; and
- d. advances in the design of all subsystems, resulting in greater payload availability for communications.

The Ford Aerospace and Communications Corporation is the prime contractor for the INTELSAT V satellites.

Table 1. INTELSAT V Performance Specifications

Mass in Orbit	967 kg
Launch Vehicle	Atlas-Centaur or STS
Frequency Bands	6/4 and 14/11 GHz with interconnect capability and frequency reuse (separate beams at both 6/4 and 14/11 GHz, and orthogonal polarization at 6/4 GHz)
Transponders	27
6/4 GHz	16 with 80-MHz bandwidth and 5 with 40-MHz bandwidth
14/11 GHz	4 with 80-MHz bandwidth and 2 with 240-MHz bandwidth.
Received Power Flux Density, Δ BW/m ²	
6 GHz	-60 to -69
14 GHz	-67 to -76.5
e.i.r.p.,* dBW	
4 GHz	22 to 29
11 GHz	44.1
Nominal Communications Capacity	12,000-14,500 voice circuits

*Specific coverage requirements differ according to the region of utilization.

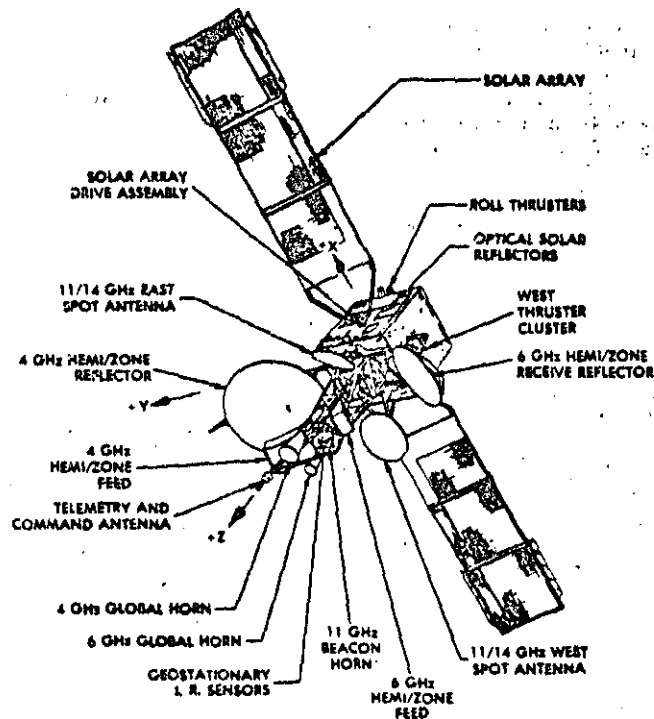


Figure 4. INTELSAT-V Configuration (Courtesy of Ford Aerospace Communications Corporation)

In conjunction with spacecraft developments, the earth segment has grown enormously, as shown in Figure 5. The INTELSAT system has grown from 5 earth stations in 1965 to 202 earth station antennas in 88 countries in 1978.

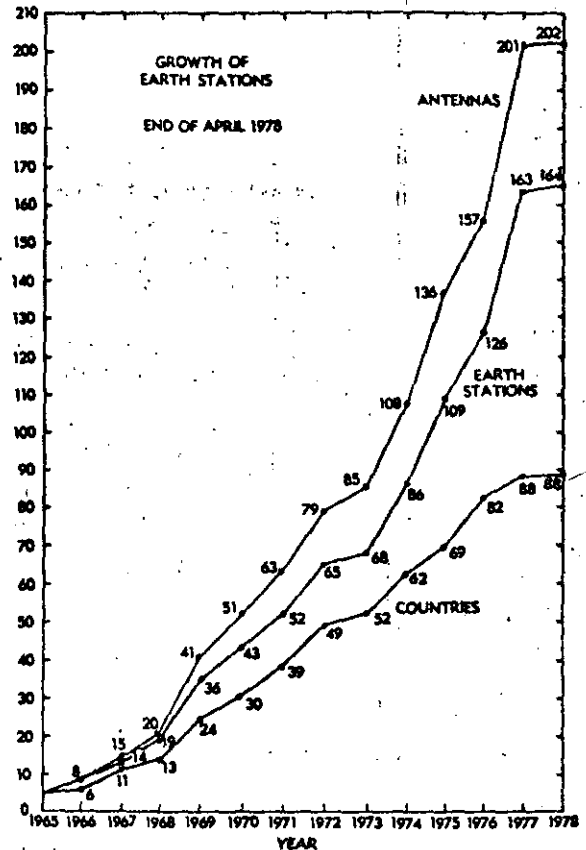


Figure 5. Earth Segment Growth in the INTELSAT System

After the early use of radome-covered horn antennas, a design previously developed for low-orbit satellites such as TELSTAR and RELAY, two kinds of earth stations have been adopted by INTELSAT. The Standard A antenna comprises a large reflector (about 30 m diameter) and liquid-helium-cooled parametric amplifiers, resulting in a G/T ratio of 40.7 dB/K. These antennas, fully steerable in azimuth and zenith, can track a geostationary satellite to within 0.02° and allow full versatility for all types of communications.

The Standard B antennas comprise a 12-m reflector with limited steerability, although the tracking requirements are identical to those of the Standard A antennas. The resultant G/T of 31.7 dB/K allows the convenient adoption of this antenna, which costs only a fraction of the previously mentioned Standard A, at terminals characterized by light traffic. A Standard C antenna will be introduced in the INTELSAT V era. This antenna will operate at 11/14 GHz and have a G/T ratio of 39.0 dB/K for 90 percent of the year.²⁰

The INTELSAT system provides continuous global telephone service in addition to television, telegraph, and data transmission. Temporary service is also

available on a short-term basis to accommodate special world events and special communications requirements. Services meet or exceed international standards of quality, while maintaining an exceedingly high level of reliability.^{21,22}

The primary operational mode of the system is multiple access, preassigned in the frequency domain. The previously mentioned SPADE, a demand-assignment multiple-access system, was introduced in 1973 and has been implemented in the Atlantic Ocean region, with 32 terminals in operation. Direct digital transmissions have been established between a number of points, and more are planned.

A transmission system known as single channel per carrier (SCPC), which provides preassigned circuits for voice and data, is available in all ocean regions. SCPC combined with pulse code modulation and phase shift keying is the standard transmission technique for standard B earth stations.

The INTELSAT system provides restoration service for interrupted submarine cables on very short notice, and permits rerouting via satellite of cable circuits which would have remained suspended for a long time while repairs are made at sea.

All real-time transoceanic television is transmitted via satellite. TV service is characterized by large fluctuations, caused by singular world events such as international political events and sports competitions.

Finally, the extra capacity of the INTELSAT space segment provides domestic communications services to various countries. Communications capacity is leased in terms of multiples of one-quarter transponder utilizing various transmission techniques which include FDM/FM, SCPC/PCM/PSK, SCPC/compressed FM, or delta modulation. This kind of service is very attractive in countries with geographical obstacles to conventional terrestrial communications. Plans for the post-1985 period envisage alternate concepts tied to advanced technologies. As the traffic projections by end of 1977 indicate the need for some 300,000 channels, new systems concepts and technologies will be required.²³

THE CANADIAN DOMESTIC SYSTEM

Canada has been the first country in the Western hemisphere to establish a multipurpose communications satellite system for domestic service. The space segment comprises three satellites in orbit, the first launched in November 1972 and operational in January 1973 at 114° west longitude, the second launched in April 1973 at 109° west longitude, and the third launched in May 1975 at 104° west longitude. The satellites were manufactured by Hughes Aircraft Co. with Canadian firms as subcontractors for the onboard communications equipment (Northern Electric) and the main structure (Spar Aerospace). The launch vehicles (Thor-Delta) and facilities were provided through NASA.

Telephone, television, data, and facsimile transmission services are provided throughout Canada, increasing the capacity of the existing terrestrial systems and permitting their interconnection. The overall transmission performance is comparable to or better than that of terrestrial systems.

The earth segment consists of over 50 stations: 2 for heavy route traffic, 6 for network television,

18 for thin route traffic, 2 for northern telecommunications, 76 for remote television service, and finally, 1 TT&C station. The operating frequency bands are from 3.202 to 4.178 GHz in the down-link (horizontal polarization), and 5.927 to 6.403 GHz in the up-link (vertical polarization).

The first generation satellites built for TELESAT Canada by Hughes Aircraft were spinners with a diameter of 190.5 cm, height of 161 cm, and in-orbit mass of 600 kg. The platform, carrying 12 transponders, spins at 100 rpm with the outer drum, which supports 20,048 silicon cells, producing 300 W of electrical power at beginning of life. The despun upper structure carries a 152.4-cm-diameter lightweight parabolic reflector illuminated by a multiple horn offset feed. The radiation pattern (about 3° x 8.5°) is elliptically shaped to cover the territory of Canada. The e.i.r.p. per transponder is 33 dBW (minimum at the beam contour) obtained by a 5-W TWT in each transponder, and the transmit antenna gain is 27 dB. A TT&C antenna on top of the parabolic reflector brings the overall satellite height to 358.1 cm.

The repeater is a fixed gain, single-conversion, 12-transponder design with 36-MHz bandwidth allocated to each channel and a 4-MHz guard band between adjacent channels. A redundant (switchable) wideband receiver using tunnel diode amplifiers at 6 GHz is common to the 12 transponders. The receive G/T ratio is -7 dB/K. Each transponder can operate with the TWT at saturation in the single-access mode, providing a capacity of 960 voice circuits or one color TV and two 5-kHz audio circuits (earth station G/T = 37 dB/K). It can also operate at backoff in the multiple-access FDM/FM/FDMA mode with varying communications capacity, depending on the circumstances. During eclipses, only 10 of the 12 transponders can be fully operational.

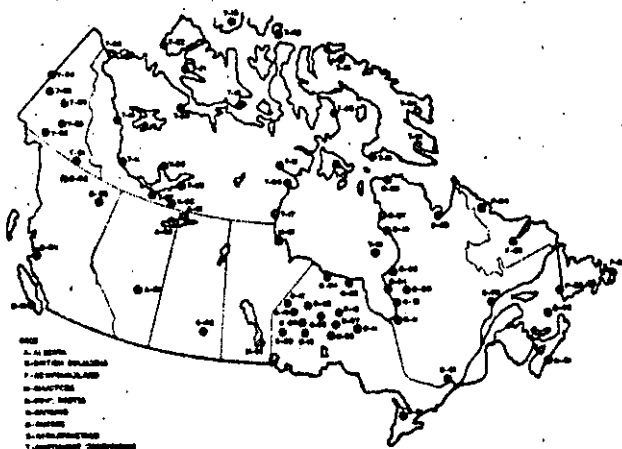
The locations of the Anik system earth stations are shown in Figure 6; their variety is considerable. The TT&C facilities, located at the two heavy route stations on the east (Allan Park, Ontario) and west (Lake Cowichan, Vancouver Island) coasts, operate in conjunction with the Ottawa control center. During the transfer orbit phase of a mission, a third TT&C station operates on the island of Guam in the Pacific.

The two heavy route stations satisfy high-density traffic requirements as well as television services. The antennas are 29.87-m-diameter parabolas, with a gain of 63 dB in transmission and 59 dB in reception. The combination of the antenna and a parametric front end yields a G/T ratio of 37 dB/K. The e.i.r.p. per carrier is 84 dBW with 960 voice circuits, or one color TV plus two audio channels. Normally, five transmit and seven receive channels with hot standbys are provided. The stations operate continuously and have tracking capabilities.

The six network television stations located near major cities provide TV signal transmission and reception for use by the CBC network. The antennas are 10.5-m-diameter parabolas with gains of 52.5 and 50.5 dB, respectively, in transmission and reception. The antennas are fixed with manual steering over a limited range. Therefore, precise satellite station-keeping is required to remain within the antenna beamwidth. The G/T is 28 dB/K and the e.i.r.p. per carrier is 83 dBW. The communications capacity per carrier is one TV plus two audio channels. Some stations are permanently manned, while others require only part-time staffing.

bandwidth and power. However, this solution is not desirable because flexibility will be lost and, in addition, spacecraft mass and service costs will increase. Standardized transponder design, with compromises in communications capacity and quality of service, was the solution finally adopted.

The careful planning of the TELESAT system has contributed to its operational success since 1973. The advanced design of the spacecraft resulted in its adoption by other users. The Hughes Aircraft Co. HS-333 spacecraft has proved highly successful and was later adopted with minor changes by Western Union for its two WESTAR satellites (1974-1975) for U.S. domestic services, and by the Government of Indonesia for its PALAPA system (1976). Two HS-333 satellites constitute the space segment of the Indonesian system; fifty 10-m earth terminals located on the various islands of the Indonesian Archipelago constitute the earth segment.



EARTH STATION INDEX

ALASKA	NORTHWEST TERRITORIES (Continued)	ONTARIO (Continued)
A-01 August	T-04 Pt. Smith	O-11 Seabrook Lake
A-02 Pt. Chisseyan	T-07 Pt. Pelet	O-12 Silver Falls
BRITISH COLUMBIA	T-08 Yellowknife	O-16 Niagara
B-01 Lake Cowichan	T-09 Kamik Inlet	QUEBEC
B-02 Cedar	T-10 Norman Wells	Q-01 Riviere Rouge
B-03 Pt. Nelson	T-11 Ft. Simpson	Q-02 Repulse Is.
B-04 Millie Wells	T-12 Baker Lake	Q-03 Repulse Is.
MANITOWA	T-13 Coral Harbour	Q-04 Pt. George
M-01 Chatham	T-14 Sea Point	Q-05 Pt. Chalm
M-02 Blair	T-15 Cape Barbert	Q-06 Point de la Baleine
NEWFOUNDLAND	T-16 Foxe Inlet	Q-07 Persepolis
F-01 Bay Bulls	T-17 Eskimo Point	Q-08 Redoubt
F-02 Port au Port	T-18 Enfield	Q-09 Saguenay
F-03 Goose Bay	T-19 Cambridge Bay	Q-10 Inoussouane
F-04 Nain	T-20 Cuppersmine	Q-11 Pt. Stuyvesant
NOVA SCOTIA	T-21 Nain	Q-12 Newcomb Campbell
N-01 Harrietsfield	T-22 Repulse Harbour	
NORTHWEST TERRITORIES	T-23 Snowfield	SARASWATI
T-01 Allan Park	ONTARIO	S-01 Uranium City
T-02 Winton	O-01 Allan Park	S-02 Du'Appelle
T-03 Red Frost Lake	O-02 Winton	TULSA
T-04 Pt. Severn	O-03 Red Frost Lake	T-01 Hattah Lake
O-05 Ft. Hope	O-04 Pt. Severn	T-02 Shi Lohore
O-06 Repulse	O-05 Ft. Hope	T-03 Okem
O-07 Repulse	O-06 Repulse	T-04 Clifton Street
O-08 Kias Lake	O-07 Landdowne House	T-05 Peru
O-09 Hubbard Dam	O-08 Kias Lake	T-06 Zion
O-10 Opita	O-09 Hubbard Dam	
O-11 Opita	O-10 Opita	

* Stations are numbered by province in order of start of service.

U.S. DOMESTIC SATELLITE SYSTEMS

The existence of an extremely well-developed and efficient earth-based communications network in the U.S. delayed the introduction of satellites for domestic communications. In addition, as previously mentioned, complex politico-economical forces contributed to further delays.

In December 1972, the U.S. Federal Communications Commission, after almost seven years of arguments, ruled on the matter of domestic communications satellites, announcing the so-called "open-sky" policy whereby the arena was open to competing private enterprise. Approximately 12 companies filed applications for domestic systems. Three companies (American Satellite, RCA, and Western Union Telegraph) established ground stations and initiated services in 1973-1974. Initial service was established through leasing available transponder capacity from the Canadian TELESAT satellites.

Western Union launched the first U.S. domestic satellite, WESTAR I, in April 1974, followed by WESTAR II in June of the same year. Commercial service was established in August 1974 with five earth terminals in New York, Los Angeles, Chicago, Dallas, and Atlanta. These stations have 15-m parabolic antennas.

The WESTAR satellites have become an integral part of the Western Union network. Telex, TWX, hot-line point-to-point, Central Telephone Bureau, telegrams, mailgrams, and Info-Master services are available in addition to point-to-point voice, data, and facsimile, and point-to-point or point-to-multipoint video.

Two satellites and five earth stations (Glenwood, New Jersey; Estill Fork, Alabama; Steele Valley, California; Cedar Hill, Texas; and Lake Geneva, Wisconsin) are now operational. Twenty satellite access cities and five television centers are connected via the Western Union surface microwave network.

The RCA domestic system began with leased transponders on the TELESAT Canada Anik II satellite. With the launches of the SATCOM spacecraft in December 1975 and March 1976, commercial services were provided to the 48 contiguous states and Alaska and Hawaii. The services include TV distribution in Alaska, toll messages and bush telephones in Alaska, private-line video, voice and data to government agencies, commercial TV and radio, and CATV program distribution to over 100 small receive-only stations.

Figure 6. TELESAT Earth Stations (Courtesy) of TELESAT Canada)

The northern telecommunications stations provide up to 132 voice channels at two far north locations. The stations are unattended and controlled from a nearby supervision and maintenance center. The antennas at these stations are 10.15-m parabolas (52.5-dB transmit and 50.5-dB receive gain), with a G/T of 28 dB/K and an e.i.r.p. of 73 dBW per carrier. Klystrons rated at 1.5 kW are used as final power amplifiers.

The thin route stations provide small communities with a limited number of telephone circuits (usually two to eight). SCPC techniques with delta modulation (32 kbit/s) and FDMA preassigned access are used, providing telephone service or combinations of voice, teletype, facsimile, and data. Increased capacity is achieved by voice activation and demand-assigned multiple-access techniques. Major characteristics of these stations are a G/T of 20 dB/K and an e.i.r.p. per voice carrier of 55-58 dBW.

The TELESAT system was the first to introduce TDMA, starting with early tests in 1971 and with commercial operation beginning in September 1975. Four hundred telephone circuits are handled at an overall transmission rate of 61.248 Mbit/s between a station at Harrietsfields, Nova Scotia (G/T = 31 dB/K), and another station at Allan Park, Ontario (G/T = 37.5 dB/K). This TDMA system replaced a 240-circuit FDMA system.

The outstanding characteristic of the TELESAT system is the variety of services provided. In general, as system organization for a given type of service does not necessarily coincide with optimization for other services, this conflict can be resolved by optimization of all services, matching different earth stations with satellite transponders of different

In the case of COMSAT General Corporation, two WESTAR satellites entirely leased to AT&T and GSAT have been integrated within the nation's telephone network. A third satellite was launched in June 1978 and is now in orbit. AT&T's earth stations are located at Three Peaks, California; Hanover, Illinois; Woodbury, Georgia; and Hawley, Pennsylvania. GSAT's earth stations are in Sunset, Hawaii; Triunfo Pass, California; and Homosassa, Florida.

The major characteristics of the three spacecraft used in the above mentioned systems are summarized in Table 2.

Table 2. Major Characteristics of U.S. Domestic Satellites

Quantity	HS332	SATCOM	COMSTAR
Mass in Orbit (kg)	297	465	810
Launch Vehicle	Delta 2914	Delta 3914	Atlas-Centaur
Primary Power (W) ^a	300	740	760
Frequencies (GHz)	4/6	4/6 ^b	4/6 ^b
nominal Bandwidth (MHz)	500	1,000	1,000
No. of Transponders	12	24	24
e.i.r.p./ Transponder (dBW)	24.5-34	26-32	27-34
Communications Capacity (2-way voice circuits)	7,000	14,000	18,000

^abeginning of life.

^bfrequency reuse with orthogonal polarizations.

The RCA SATCOM spacecraft, the first operational body-stabilized communications satellite, was launched by a modified 3914 Thor-Delta vehicle. Its communications capacity is 14,400 voice circuits with 24 transponders and frequency reuse by means of orthogonal linear polarization.

The COMSTAR spacecraft, the largest of the three, has 24 transponders, and again dual polarization yields a total communications capacity of 18,000 voice circuits.

American Satellite Corporation, although it does not have satellites of its own, has installed 21 earth stations. SCPC techniques are used for digital transmission ranging from 56 Mbit/s to 1.344 Mbit/s. Modest antenna size (10-meter parabolas), unattended operation, installation at the user's premises, high reliability, and low cost have been key elements in the success of the system. American Satellite Corporation has also been carrying commercial traffic for a number of users such as Dow Jones (Wall Street Journal), Sperry, and Boeing.

Certain characteristics of the four domestic systems now operational in the U.S. are indicated in Table 3. Currently, there are six operational spacecraft with 96 available transponders. The total available communications capacity amounts to 57,600 voice circuits. Otherwise, each transponder can carry digital transmissions at the rate of 60 Mbit/s to yield a 5,760-Mbit/s total digital communications capability.

Notwithstanding the differences among the four operational U.S. domestic systems, the following goals have been achieved:

- satisfactory integration with the nation's earth-based networks;
- connectivity among widely dispersed points;
- direct connection avoiding local interconnection problems;
- high-speed, high-reliability data transmission permitting the efficient linking of computers; and
- broadcast-mode TV distribution to receive-only stations.

Table 3. U.S. Operational Domestic Systems (1977)

Company	S/C Designation (No. of Transponders)	Launch Date	Orbital Position (°W)	Earth Station Dia (m)	No. of Earth Stations
Western Union	WESTAR ^b (12)	4/3/74 10/10/74	99 123.5	15.5	5
RCA American Comm.	SATCOM ^c (24)	12/13/75 3/26/76	119 135.8	10	5
COMSAT General Corp./ AT&T-GSAT	COMSTAR ^c (24)	15/13/76 7/22/76	128 94	30	5 + 3
American Satellite ^d Corp.	-	-	-	10 5	21

^aall satellites use the 4/6-GHz frequency bands.

^bMAC HS333 Type.

^cfrequency reuse with orthogonal linear polarizations.

^dleases capacity from WESTAR satellites.

U.S. domestic satellite systems are expected to expand, particularly in those areas where earth-based systems are less developed (e.g., Alaska). The Public Broadcasting Service (PBS) will become the first nationwide TV broadcast network interconnected via satellite.²⁴ PBS stations, supported by the Federal government and by the contributions of viewers, carry no advertising. Terrestrial cable and microwave circuits currently leased from the common carriers at high cost will be replaced by satellites. The PBS satellite network will consist of a central program-originating station in Washington, D.C., five regional stations, and about 150 receive-only stations.

Other entities exploring satellite interconnections are the Corporation for Public Broadcasting and the Public Service Consortium. The Corporation for Public Broadcasting will seek FCC approval to provide satellite interconnections for over 200 radio stations, broadcasting audio monaural and stereophonic programs. The Public Service Satellite Consortium consists of consumer groups, educational institutions, medical organizations, and other similar entities. Plans to service communities, universities, and hospitals are being defined.

As a result of the growth in all three current areas of service, i.e., high-density trunking, thin routes, and distribution, the available communications capacity of the existing systems will eventually become fully utilized, although their saturation date will be delayed by more efficient transmission techniques. Recent estimates indicate that around the mid-1980's, utilization of higher frequency bands at 11/14 GHz will be necessary. By the late 1980's or early 1990's, the 20/30-GHz bands may be needed.²⁵

The trend will also be toward an all-digital approach for the most diverse kinds of traffic. In this context, the system announced by Satellite Business Systems (SBS), a partnership of COMSAT General Corporation, International Business Machines Corporation, and Aetna Casualty and Surety Company, deserves special mention.²⁶ In December 1975, SBS filed with the FCC for approval to construct a domestic satellite system to provide private-line networks. On February 8, 1977, FCC approval was obtained, and since then, progress has been made toward the definition of the system. The system will include:

- a. use of 11- and 14-GHz bands;
- b. all-digital transmission with time domain on-demand multiple access;
- c. integrated voice, data, and image services;
- d. unattended earth stations;
- e. 5- and 7-meter earth station antennas located at the customers' premises;
- f. minimum dependence on terrestrial interconnections;
- g. centralized system management facilities; and
- h. means to enable customers to dynamically control their networks.

The space segment will consist of a primary operational satellite, a second operational spacecraft as an in-orbit backup, and a third satellite as a ground spare. Table 4 lists the major characteristics of the spacecraft. The Hughes Aircraft Company will construct these spacecraft, which will use a dual-spinner configuration. Spacecraft design will be compatible with both the STS or Delta 3910 launch vehicles. These launch vehicles will be employed to inject the satellite into a parking orbit, a perigee stage will be used for injection into transfer orbit, and an apogee motor incorporated in the satellite will be fired for injection into geostationary orbit.

Table 4. SBS Spacecraft Performance Specifications

Launch Vehicle	STS or Delta 3910
Launch Date	1980
Frequencies (GHz)	11/14
No. of Transponders	10
Transponder Bandwidth (MHz)	43
e.i.r.p./Transponder (dBW)	43, 39, 37
Nominal Communications Capacity (2-way voice circuits)	12,000-14,000

Each satellite will carry 10 transponders, with a nominal bandwidth of 49 MHz. Traveling wave tubes with 23-watt output power will be used as final amplifiers. Full solar eclipse capability will be maintained. The satellites will each carry one active and three spare wideband receivers and ten communications channels, including ten active and six spare TWTAs. Parabolic reflectors, one for receiving and two for transmitting, will be used with multiple feeds and a maximum gain of no less than 32 dB.

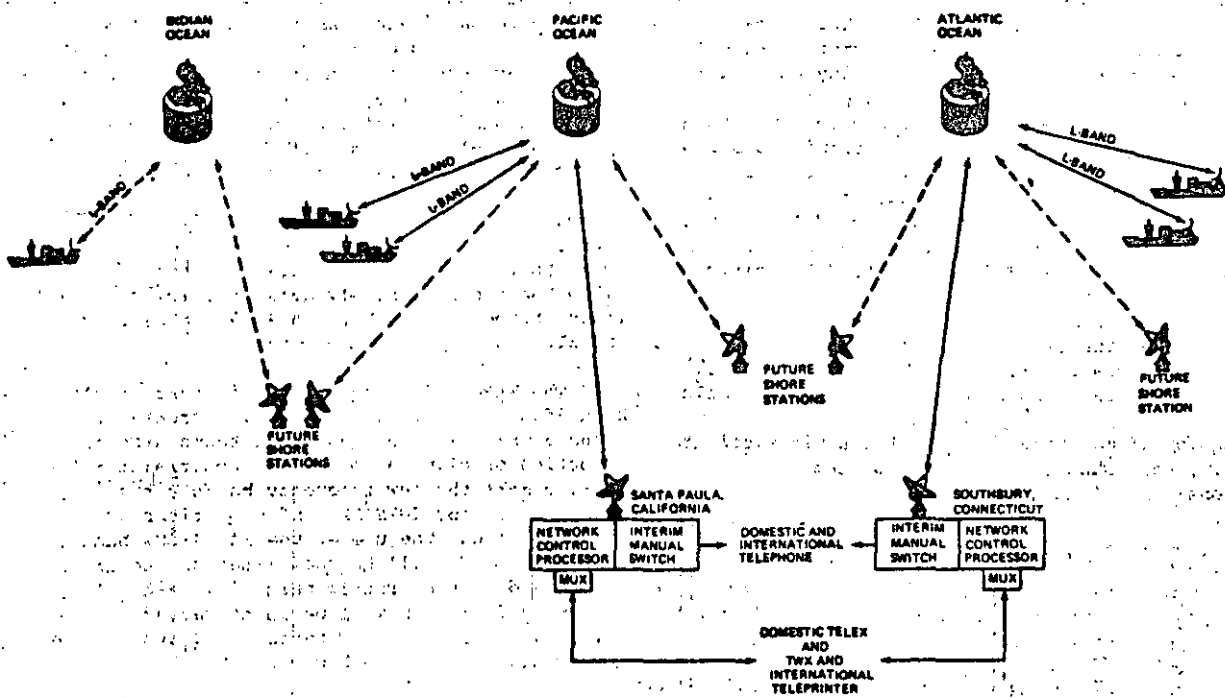
In the earth segment, earth stations interfacing with customer-provided PBXs, foreign exchange lines, data terminals, and other equipment will be designed for unattended operation. Five- and seven-meter antennas and 500-watt HPAs will be employed. Small earth stations at the user's premises will constitute a fully switched, wideband communications network with minimum need for terrestrial access facilities. Through the use of demand assignment, the satellite will enable low-density traffic nodes to be served as effectively as high-density nodes. The RF link is designed for a 99.5-percent availability (i.e., BER < 1×10^{-4}). With a raw bit rate of 43 Mbit/s and 10 active transmission channels, the overall spacecraft capacity is 430 Mbit/s.

MOBILE SYSTEMS

In 1976 the MARISAT system inaugurated a new era in maritime communications, which previously suffered from the limited communications capacity and low reliability of conventional radio from VLF to HF. Satellites have made possible highly reliable, high-quality voice, data, facsimile, and teletype services to and from ships. Interconnection with domestic and international networks makes the system doubly attractive. Currently, 106 shipboard terminals are operational.

The MARISAT system is also unique because its spacecraft constitute the first example of multipurpose operational communication platforms, since UHF channels are available to the U.S. Navy while SHF channels are available to commercial users.

Figure 7 shows the deployment of the system, Figure 8 its coverage, and Figure 9 the spacecraft and its major characteristics. Three distinct transponders are available on the spacecraft. The first operates at 300/250 MHz, providing half-duplex transmission in three separate channels, one 480 kHz wide, and the other two 24 kHz wide used for U.S. Navy purposes. The second transponder is a 1.64/4.19-GHz wideband repeater used for ship-to-shore commercial traffic. The third is a 6.42/1.53 GHz wideband repeater used for shore-to-ship and ship-to-ship.



NOTE: ALL SHORE STATION/SATELLITE LINKS USE 8.4 GHz FOR COMMUNICATIONS AND 1.8/1.5 GHz FOR AFC.

Figure 7. MARISAT System Deployment. (from COMSAT Technical Review Vol. 7, No. 2, Fall 1977)

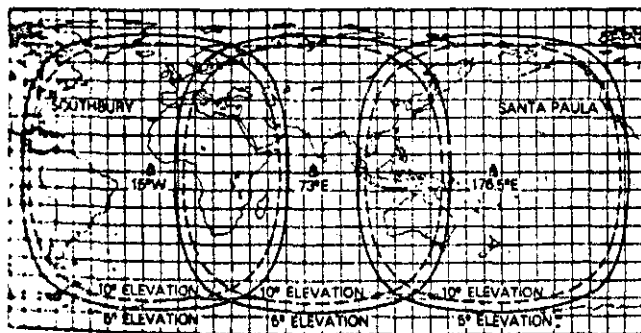


Figure 8. MARISAT Coverage (from COMSAT Technical Review, Vol. 7, No. 2, Fall 1977)

The commercial voice-grade channels are allocated on an SCPC basis using frequency modulation. The telegraph channels are time-division multiplexed (TDM) in the ship-to-ship direction and time-domain multiple accessed (TDMA) in the ship-to-shore direction with channels sharing the same carrier. Channel assignment and signaling information is integrated into the telegraph TDM carrier. A single frequency is shared by the ship's terminals on an as-needed basis for channel requests. A voice-grade call is set up by selecting two frequencies at the shore station and assigning them to a specific mobile terminal.



YEAR OF FIRST LAUNCH	1976
DIMENSIONS:	
DIAMETER (m)	2.16
HEIGHT (m)	1.63
IN-ORBIT MASS (kg)	325
LAUNCH VEHICLE	THOR DELTA 2914
PRIMARY POWER (W)	300
UHF REPEATER	
NOMINAL RECEIVE FREQUENCY (MHz)	300
G/T (dB/K)	-18
CHANNEL BANDWIDTH (kHz)	480, 24, 24
NOMINAL TRANSMIT FREQUENCY (MHz)	250
e.i.r.p. (dBW)	28, 23, 23
SHF REPEATER	
RECEIVE BAND (GHz)	6.420-6.424, 1.6385-1.6625
G/T (dB/K)	-25.4, -17
TRANSMIT BAND (GHz)	1.537-1.541, 4.195-4.199
e.i.r.p. (dBW)	20, 26, 29.5, 18.8

Figure 9. MARISAT Spacecraft Characteristics

For telegraph calls, the assignment of frequency pairs is different; the shore-to-ship TDM carrier is PSK-modulated by a 1,200-bit/s stream. The ship-to-shore TDMA channel is filled by gated bursts transmitted in a prearranged sequence by as many as 22 different ships. Each burst is PSK modulated at 4,800 bit/s and carries up to 12 message characters. As the time reference for the ship's transmissions is derived from the continuously received TDM signal, no synchronization is necessary. Adequate time between bursts accommodates different propagation delays within the coverage and voice area. Voice-grade circuits can handle speech, facsimile, and data up to 2,800 bit/s.

The communications capacity depends upon the operating mode of the L-band satellite transmitter. Distress and broadcast remote type messages are also possible. Reference 9 should be consulted for details.

Expansion of maritime communications via satellite is foreseen, and plans are being formulated for an international organization in this area. The Inter-Governmental Maritime Consultative Organization (IMCO) established in 1972 a panel of experts to study the technical, economic, and operational factors involved in future commercial maritime communications systems via satellite. During several important meetings the relationship between the existing operational MARISAT system and future possible systems such as MAROTS and MARECS have been investigated.

There are clearly other possibilities for satellite communications to mobile users. Plans for an aeronautical satellite system (AEROSAT) were actively pursued from 1975 to 1977 by the U.S., Canada, and various European countries. Although the project came to a standstill, mostly because of economical and institutional obstacles, the potential advantages of such a service are sufficiently well defined.

FUTURE TRENDS, SPECTRUM AND ORBIT UTILIZATION

Satellite communications systems will continue to expand because traffic growth forecasts indicate the need for greater communications capacity. For example, the yearly average growth rate in the INTELSAT system is expected to be at least 15 percent in the next decade. Satellites will therefore become more competitive vis-a-vis other systems—in terms of increasing communications capacity, reliability, flexibility, and cost effectiveness. In addition, satellites will permit many new communications services to be offered.

The two natural resources, the electromagnetic spectrum and the geosynchronous orbit, determine the bounds of satellite communications' ultimate growth, and will be briefly discussed in the following paragraphs.

As latecomers among the users of the electromagnetic spectrum, satellite services were not assigned "optimum" spectral regions. The assignment to fixed satellite services of 500 MHz at around 4 and 6 GHz for the down- and up-links, respectively, only approaches an optimum allocation since the noise power density spectrum exhibits a broad minimum between 1 and 2.5 GHz. In addition, power flux density limitations were imposed on satellite systems because the 4- and 6-GHz frequency bands must be shared with existing terrestrial microwave systems. In spite of these constraints, satellite systems have been extremely successful, the most serious limitation probably being that which derives from the constraints on the growth of the system.

All commercial satellite systems at this time operate at 4 and 6 GHz. Among the frequency bands assigned to satellite communications at the World Administrative Radio Conference of 1971 two new pairs of bands are especially attractive: one at 11 and 14 GHz, and another at 19 and 29 GHz. At 11 and 14 GHz, a bandwidth of 500 MHz is available for the down- and up-links, respectively. These bands are shared with terrestrial services and are subject to power flux density limitations. There is 2,000 MHz of shared spectrum available between 17.7 and 19.7 for down-links, and another 2,000 MHz between 27.5 and 29.5 GHz for up-links. Finally, bandwidths of 1,500 MHz are exclusively available for down- and up-links, respectively, between 19.7 and 21.2 GHz and 29.5 and 31.0 GHz.

The WARC 1971 frequency assignment results in bandwidth availability eight times greater than that at 4 and 6 GHz. The decrease in antenna size and the reduction or elimination of the constraint related to sharing make the new frequency bands attractive. Future plans for INTELSAT and domestic or regional systems include the use of the 11/14-GHz bands. The 19/29-GHz bands will be used later as the art progresses and as the traffic needs increase. Attenuation resulting from rain will be counteracted by adequate power margins, diversity techniques, and special coding techniques combined with diversity.

Several years ago it was pointed out^{27,28} that communications capacities of the order of 100,000 telephone circuits per satellite could be attained without excessive demands on satellite mass and power. Increases in capacity at least one order of magnitude above that of current satellites can be achieved by introducing advanced technologies such as:

- a. 3-axis body stabilization,
- b. higher efficiency solar cells (e.g., "Violet" and non-reflective cells),
- c. higher efficiency energy storage devices (e.g., nickel-hydrogen batteries),
- d. electrical propulsion for stationkeeping and positioning,
- e. frequency reuse with orthogonal polarization and multiple-beam antennas,
- f. onboard switching with combined time- and space-domain multiple-access,
- g. onboard regeneration of digital signals,
- h. transponder linearization,
- i. hybrid modulation techniques,
- j. source and baseband encoding, and
- k. intersatellite links.

Table 5 summarizes the status and the potential of various technologies.

Antenna gain affects both e.i.r.p. and usable bandwidth because capacity is proportional to power and usable bandwidth, the latter being determined by the frequency reuse factor. Precise stationkeeping and positioning and orientation techniques are needed with narrow antenna beamwidths. The advantages obtained are clear, for example, a beamwidth of 1° yields a gain increase of 360 times with respect to a 19° beamwidth for global coverage, i.e., a 25.8-dB improvement.

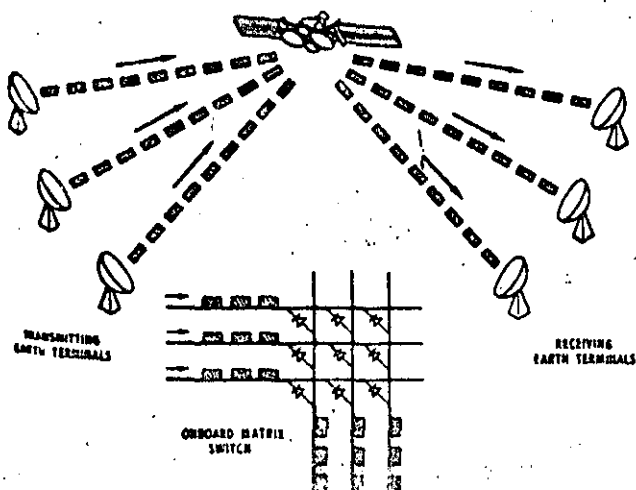
Multibeam antennas yield higher e.i.r.p. toward given areas and allow frequency reuse, but require interconnection capability to provide multipoint services. Hence the combination of multibeam antennas and satellite-switched TDMA (SS-TDMA) techniques is especially attractive.

Table 5. Status and Potential of Various Technologies

Item	Operational in Space	Experience		Untried in Space	Increase in Communications Capacity	Other Advantages
		in Space	in Lab			
Body Stabilization	✓				30%-40%	Easier deployment of complex antennas
High-Efficiency Solar Cells	✓				5%-7%	-
H ₂ Batteries	✓				5%-15%	Longer life
Ion Propulsion		✓	✓		30%-40%	Longer life, increased pointing accuracy
Multibeam Antennas	✓					
Spectrum Reuse					Proportional to frequency reuse factor	-
- Via Orthogonal Polarization	✓					
- Via Separate Beams	✓					
Higher Frequencies		✓			Proportional to available bandwidth	Smaller antennas
TDMA/SS-TDMA	✓	✓	(✓)	(✓)	Up to 100%	-
Source Encoding (DSI-SPEC-CODIT)		✓			Up to 100%	-
Regenerative Repeaters			✓	✓	50% or more	Better error control
Intersatellite Links		✓			N.A.	Increased connectivity

Figure 10 shows a possible system configuration combining TDMA with SS/TDMA. A spaceborne distribution center, consisting of a switching matrix and a control unit, provides the interconnection of different transponders. Information about traffic flow is stored in onboard memory circuits that control the switching matrix; command signals from the earth rearrange the connections in the matrix whenever necessary. Three important advantages result from SS/TDMA. With a single carrier present at any given time, the TWTs operate at saturation with maximum conversion efficiency, no intermodulation noise is produced, and the weight penalty of the multiplexing filters required in TDMA is eliminated.

SATELLITE SWITCHED-TDMA



The introduction of advanced technologies, plus the increased reliability and longer in-orbit lifetime of the spacecraft, will lead to a progressive reduction of the space segment cost.

The theoretical bound of communications capacity per unit of bandwidth and per unit of angular separation is determined by radiation spillover on the basis of the following assumptions.²⁹

- ideal modulation-demodulation processes;
- neglect of thermal noise, i.e., no power limitations;
- sharing of a given bandwidth by satellites uniformly spaced in equatorial synchronous orbit; and
- earth station antennas with uniformly illuminated apertures.

The noise power is a function of a single geometric variable, the satellite spacing. When differences in slant range are neglected, an optimum space $\Delta\theta = \lambda/D$ yields a communications capacity per units of bandwidth and angle:

$$C = 2 \frac{D}{\lambda} \text{ bit/s/Hz/rad} \quad (6)$$

where D is the earth station diameter and λ the operating wavelength. Consequently, the maximum transmission rate (bit/s) which can be handled by a satellite system using a bandwidth B and a segment of synchronous orbit spanning θ rad is

$$R = 2 \frac{D}{\lambda} B\theta \text{ bit/s} \quad (7)$$

capacity of 2.51×10^{12} bit/s, i.e., approximately 40 million telephone channels.

In practice, results of this kind must be corrected to include possible mechanical problems resulting from tight orbital spacing, the lower efficiency of real modulation-demodulation processes, the unavoidable presence of thermal noise, intermodulation noise, and actual antenna radiation patterns. While the first four items lead to lower communications capacities, the last item can lead to an increase in communications capacity beyond the above mentioned theoretical bound.

Additional possibilities for augmenting communications capacity are intersatellite relaying, increase in the allowable interference ratio, channel interleaving, reversed use of frequencies, and pseudo-stationary satellites and 2-dimensional orbit space.³⁰

Clearly, as the two problems of spectrum and orbit utilization are inseparable, tradeoffs are possible.³¹ At 4/6 GHz the current value of the orbital spacing (around 4°) is primarily dictated by the earth station size within the current range of 10-30 meters. Increased satellite e.i.r.p., accompanied by reduction of the size (cost) of the earth station antennas, leads unavoidably to a less efficient utilization of the orbit because of the wider satellite spacing required. A reduction of the number of spacecraft in geosynchronous orbit, conceivable by combining services on multipurpose platforms (an approach which may be desirable for other reasons), would also lead to reduced communications capacity. Improvements in antenna sidelobe control techniques (including signal processing antennas) will ultimately be required to avoid wasteful use of the geosynchronous orbit.

In all cases, of course, the opening of higher frequency bands or the availability of additional bands leads to better orbit utilization and higher communications capacity.

CONCLUSIONS

Striking progress has been made in technology, operational use, institutional arrangements, and cost effectiveness of communications satellite systems in their first decade of deployment. Continued progress is expected through the expanded use of existing international, domestic/regional, and mobile systems. Further progress will occur as systems and services come into being.

Future systems will have greater capacity and flexibility to serve a variety of users. Increased reliability, longer lifetime, in-orbit servicing, and the introduction of new technologies will contribute to progressive cost reductions in both the space and earth segments.

The higher frequency bands will be occupied in addition to the continued use and improved exploitation of the lower frequency bands already occupied. Advanced spacecraft, signal processing, and microwave technologies, combined with earth terminal development slanted toward automated operations and greater reliability, will contribute to the progress of satellite communications systems well beyond the achievements recorded in the first decade of commercial operation.

ACKNOWLEDGMENT

Thanks are offered to the International Astronautical Federation (IAF) and in particular to Prof. B. G. ...

the XXVth IAF Congress, and Pergamon Press, the publishers, for their kind permission to allow parts of Reference 5 to be incorporated in this paper.

The encouragement of Dr. B. I. Edelson, Director of COMSAT Laboratories, is also gratefully acknowledged.

REFERENCES

1. A. C. Clarke, "Extraterrestrial Relays," Wireless World, October 1945, pp. 305-308.
2. C. E. Shannon, "The Mathematical Theory of Communication," Bell System Technical Journal, Vol. 27, No. 3, July 1948, pp. 379-428; Vol. 27, No. 4, October 1948, pp. 623-656.
3. J. R. Pierce, "Orbital Radio Relays," Jet Propulsion, Vol. 25, April 1955, pp. 153-157.
4. I. Goldstein, "INTELSAT and the Developing World," IEEE Transactions on Communications, COM-24, No. 7, July 1976, pp. 742-748.
5. P. L. Bargellini and B. I. Edelson, "Progress Trends in Commercial Satellite Communications--A Survey," Proc. of the XXVI International Astronautical Congress, Lisbon, Portugal, 1975, L. G. Napolitano, Pergamon Press, 1976, pp. 259-276.
6. D. G. Thorpe, "Evolution of the TELESAT Canada System into the Mid-1980's," Satellite Communications: Future Systems, D. Jarett, ed., New York: AIAA Press, 1977, pp. 39-55.
7. C. C. Sanderson and B. R. Elbert, "Communication System Design of the Indonesian Domestic Satellite System," WESCON 1976, Los Angeles, CA, Paper No. 9.2.
8. P. L. Bargellini, "Evolution of U.S. Domestic Satellite Communications," Proc. of 3rd Jerusalem Conf. on Information Technology, August 1978, J. Moneta, ed., North Holland Publishing Co.
9. D. W. Lipke et al., "MARISAT--A Maritime Satellite Communications System," COMSAT Technical Review, Vol. 7, No. 2, Fall 1977, pp. 351-391.
10. J. V. Charyk, "Communications Satellites," Von Karman Lectureship in Astronautics, AIAA 13th Annual Meeting, Washington, D.C., 1977, Paper No. 77-323.
11. W. L. Pritchard, "Satellite Communication--An Overview of the Problems and Programs," Proc. IEEE, Vol. 65, No. 3, March 1977, pp. 294-307.
12. H. Rosen, "Synchronous Communications Satellites," Space Communications, A.V. Balakrishnan, ed., New York: McGraw-Hill, 1963, Chapt. 17.
13. S. Metzger, "Foreword," COMSAT Technical Review, Vol. 2, No. 2, Fall 1972, pp. vii-xi.
14. J. Kiesling et al., "A Technique for Modeling Communications Satellites," COMSAT Technical Review, Vol. 2, No. 1, Spring 1972, pp. 73-104.
15. New Space Transportation Systems--An AIAA Assessment, J. Preston Layton and Jerry Grey, ed., New York: AIAA Press, 1973.
16. Space Transportation Systems--User Handbook, NationalAeronautics and Space Administration, June 1977.
17. M. H. Kaplan, Space Shuttle: America's Wings to the Future, Fallbrook, CA: Aero Publishers, 1978.
18. "The INTELSAT-IV Communications System," P. L. Bargellini, ed., COMSAT Technical Review, Vol. 2, No. 2, Fall 1972, pp. 437-572.
19. R. J. Rusch et al., "INTELSAT V Spacecraft Design Summary," AIAA 7th Communications Satellite Systems Conference, San Diego, CA, April 24-27, 1978, A Collection of Technical Papers, pp. 8-20.
20. M. P. Brown, Jr., "INTELSAT V Standard C Earth Station Performance Objectives," EASCON '77, ...

c. Brown, "The INTELSAT Global Satellite Communications System," COMSAT Technical Review, Vol. 4, No. 2, Fall 1974, pp. 477-488.

22. B. I. Edelson et al., "INTELSAT System Reliability," International Astronautical Federation XXVth Congress, Amsterdam, The Netherlands, 30 September-5 October 1974.

23. H. Van Trees et al., "Planning for the Post-1985 INTELSAT System," AIAA 7th Satellite Systems Conference, San Diego, CA, April 24-27, 1978, A Collection of Technical Papers, pp. 43-54, Reprint Paper 7.1.

24. A. Washburn, "U.S. Domestic Communications Satellite Systems," International Astronautical Federation XXVIIIth Congress, Prague, Czechoslovakia, 25 September-1 October 1977, Paper No. 77-01.

25. D. Jarrett, "Meeting the Twin Challenges of Demand and Conservation of Spectrum and Orbit Through Technology," EASCON '77, Washington, D.C., September 1977, Proceedings, pp. 25.1A-25.1H.

26. J. D. Barnla and P. R. Zitzmann, "The SBS Digital Communications Satellite System," EASCON '77, Washington, D.C., September 1977, Reprint Paper 2.2.3.

27. W. L. Pritchard and P. L. Bargellini, "Trends in Technology for Communications Satellites," Astronautics and Aeronautics, Vol. 10, No. 4, April 1972, p. 26.

-28. J. J. Knopow, "Next Generation Communications Satellites," Communications Satellite Systems (AIAA Progress in Astronautics and Aeronautics, Vol. 32), P. L. Bargellini, ed., Cambridge, MA: MIT Press, 1974, pp. 63-86.

-29. W. E. Bradley, "Communications Strategy of Geostationary Orbit," Astronautics and Aeronautics, Vol. 6, No. 4, April 1968, p. 34.

30. P. L. Bargellini, "Extension of the Concept of Satellite Communication System Capacity to a Two-Dimensional Model," ICC '69, Boulder, CO, June 9-11, 1969, Conference Record, pp. 37-25-37-29.

31. R. C. Davis et al., "Future Trends in Communications Satellite Systems," ACTA Astronautica, Vol. 5, No. 3-4, March-April 1978, pp. 275-298.

Part VIII

Regulatory, Political, Legal, and Economic Issues

Most of the papers up to this point have emphasized the technical aspects of satellite communications. The political, regulatory, and economic issues are of equal, or perhaps greater, importance.

The first area of interest is orbit and spectrum utilization. As Fig. 1 (from [1]) graphically illustrates, the number of satellites in geostationary orbit is increasing rapidly. In the 4 and 6-GHz band, there are already segments of the orbital arc where intersatellite interference is an issue. Appendix Paper 8.1 provides an overview of the problem. Some of the measures identified in the paper which will increase the efficiency of orbit-spectrum utilization include segregation of networks according to their interference potential, improvement of satellite and earth-station

antenna sidelobe patterns, and various standardization guidelines. Reference [2] provides a survey of interference problems and their application to the orbit utilization problem. The reader should note the similarity between these interference results and those in the digital modulation section (3.3). References [3]-[6] discuss various aspects of the spectrum and orbit utilization problem.

A second related area is the management of the spectrum and orbit. Decisions made at the World Administrative Radio Conference scheduled for 1979 (WARC-79) could have a significant impact on satellite communications. Reference [7] discusses some of the issues that will be important at the 1979 WARC.

A third area of interest is the availability and costs of

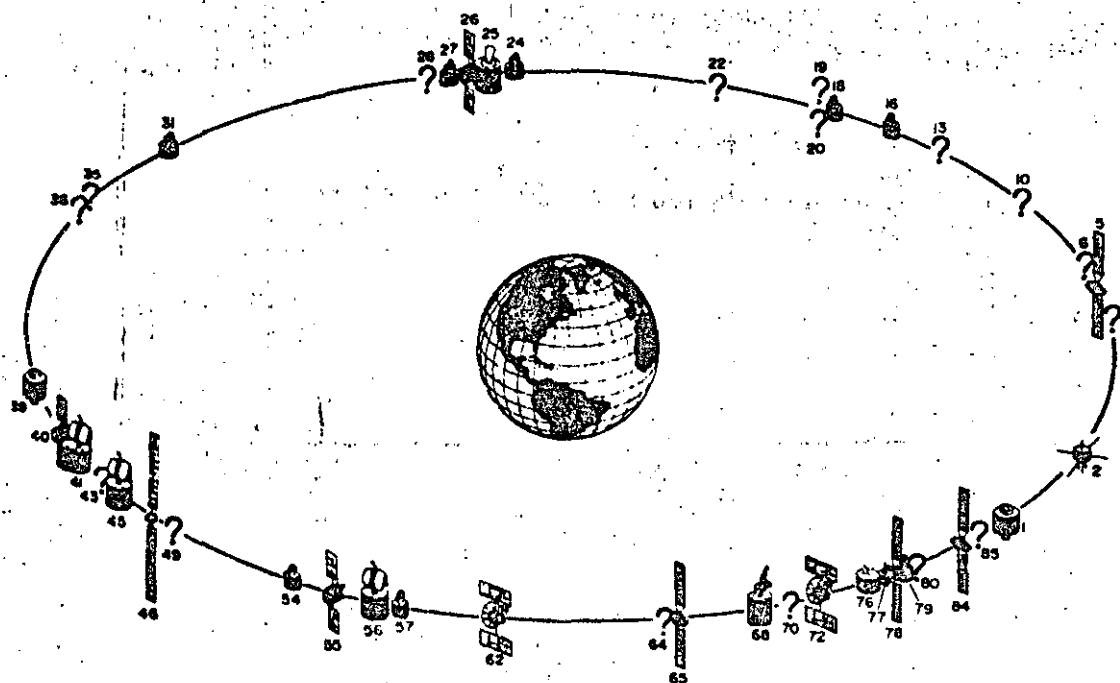


Fig. 1. Geosynchronous satellites launched or to be launched after January 1, 1976 from [1].

launch vehicles. There are three factors in the launch vehicle area which will be significant in the 1980's. They are 1) the charging policy for the Space Transportation System (Shuttle) and the availability, capability, reliability, and any limitations associated with the shuttle orbit to synchronous orbit booster; 2) the continued availability of U.S. launch services for expendable launch vehicles; and 3) the development of non-U.S. launch capacity. Assuming that the Shuttle costs and availability meet its goals, it will clearly play a dramatic role in the development of communication satellite capability, including being a significant influence on technological priorities and satellite design practices.

Currently, Japan and the U.S.S.R. have their own launch capabilities, and ESA is developing the ARIANE launch vehicle. The U.S.S.R. launch capabilities could potentially impact strongly in the marketplace if they decide to sell launch services.

A fourth area is the growth of regional systems. The questions with respect to regional systems concern the number of such systems to be developed and their impact on and relation to INTELSAT. The Arab Telecommunication Union is moving rapidly to implement a regional system for the Arab countries, and an African system has been proposed. The ECS system, managed by EUTELSAT, is proceeding toward operation.

The 1980's can be expected to be a period of significant sorting out of the relative advantages and economics of the various system options available (e.g., dedicated satellites versus leased transponders, regional versus domestic systems). National goals and priorities, as well as technology and economics, will play a significant role in the decisionmaking process.

A fifth, and perhaps dominant, area is the legal and regulatory environment. There are a number of current actions that will have a major impact on the future of satellite communications, e.g., the cable-satellite question and the appeal of the original authorization of the SBS. However, the dominant long-term factor will be the revision of the Communications Act of 1934, the "Van Deerlin" bill. The

outcome of this legislation may affect the entire communications industry in a dramatic manner. References [8]-[10] discuss various aspects of the legal, political, and regulatory environment.

A sixth area can be labeled "government decisions." The question of future NASA involvement in research and development in the communications satellite area is currently being reexamined. The outcome of these discussions will affect both the rate and nature of various technological developments.

Currently, the U.S. Navy is leasing part of the capacity on MARISAT. It has recently made a commitment for a LEASAT which will serve as a follow-up to this service. NASA is proceeding with a lease arrangement on the TDRSS system. Future government policies regarding leasing of services and/or systems will influence the structure and economic viability of various proposed systems.

Various papers in the Bibliography discuss numerous aspects of these problems.

REFERENCES

- [1] W. L. Morgan, "Satellite utilization of the geosynchronous orbit," *Comsat Tech. Rev.*, vol. 6, no. 1, Spring 1978.
- [2] M. C. Jeruchim, "A survey of interference problems and applications to geostationary satellite networks," *Proc. IEEE*, vol. 65, no. 3, pp. 317-329, Mar. 1977.
- [3] W. E. Bradley, "Communications strategy of geostationary orbit," *Astronautics and Aeronautics*, vol. 6, pp. 34-41, Apr. 1968.
- [4] J. C. Fuenzalida, "A comparative study of the utilization of the geostationary orbit," *Proc. Int. Conf. Digital Satellite Communication, Intelsat/IEEE*, pp. 213-225, 1969.
- [5] J. L. Hult and E. E. Reinhardt, "Satellite spacing and frequency sharing for communication and broadcast services," *Proc. IEEE*, pp. 118-128, Feb. 1971.
- [6] J. K. S. Jowett and A. K. Jefferis, "Ultimate capacity of the geostationary-satellite orbit," *Proc. IEEE*, vol. 116, pp. 1304-1310, Aug. 1969.
- [7] Federal Communications Commission, "Report and Order in Docket 20271: Preparation for the 1979 General World Administrative Radio Conf. (GWARC), Dec. 6, 1978.
- [8] R. G. Gould, "Regulatory aspects of digital communications," *IEEE Trans. Commun.*, vol. 24, no. 1, Jan. 1976.
- [9] W. R. Hinchman, "Public policy and the domestic satellite industry," *Int. Conf. Communications*, June 1972.
- [10] "Space Broadcasting," *Journal of Space Law*, vol. 3, Spring-Fall 1975.

27

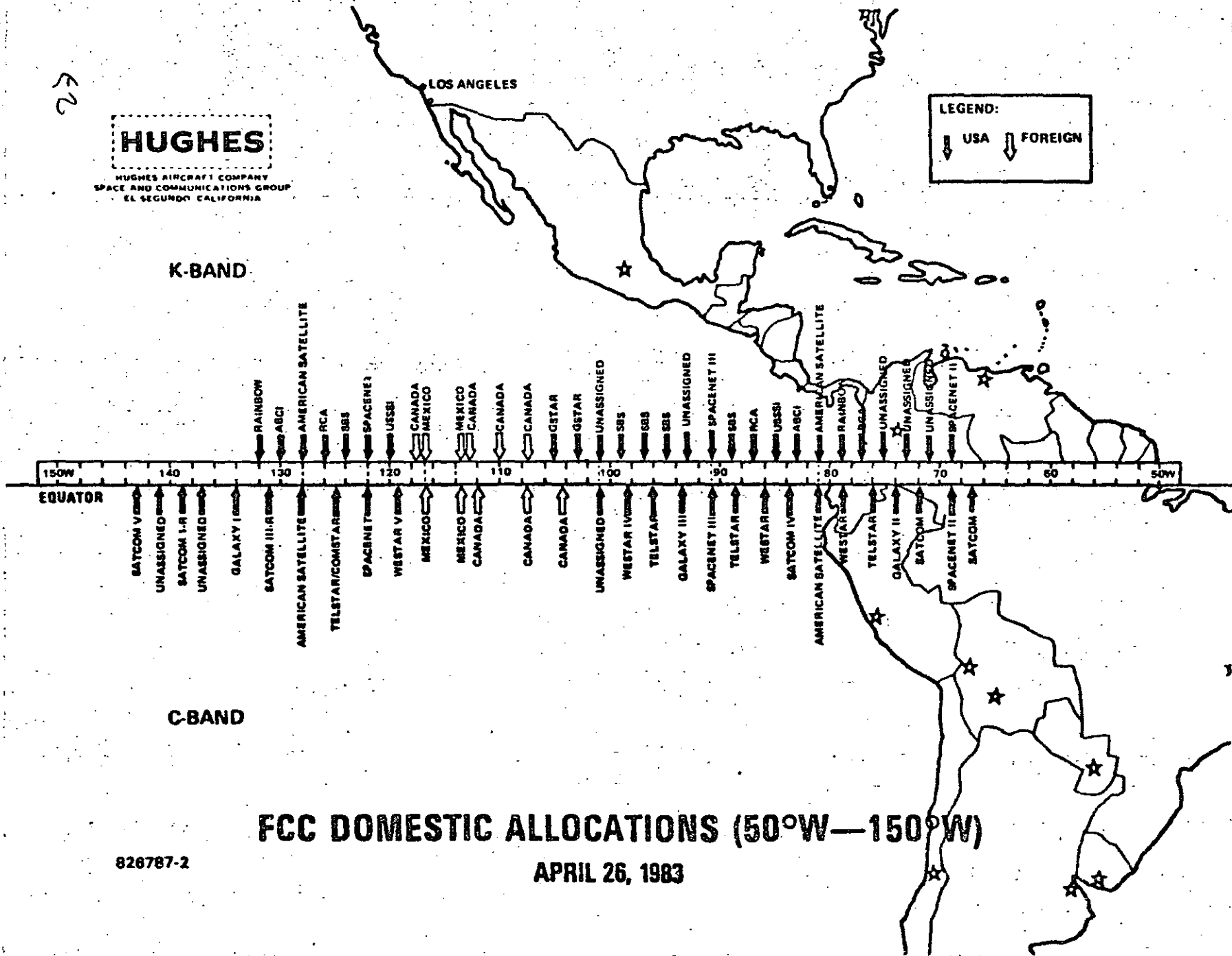
HUGHES

HUGHES AIRCRAFT COMPANY
SPACE AND COMMUNICATIONS GROUP
EL SEGUNDO, CALIFORNIA

LEGEND:
↓ USA ↓ FOREIGN

K-BAND

C-BAND



FCC DOMESTIC ALLOCATIONS (50°W—150°W)

APRIL 26, 1983

826787-2

813 27

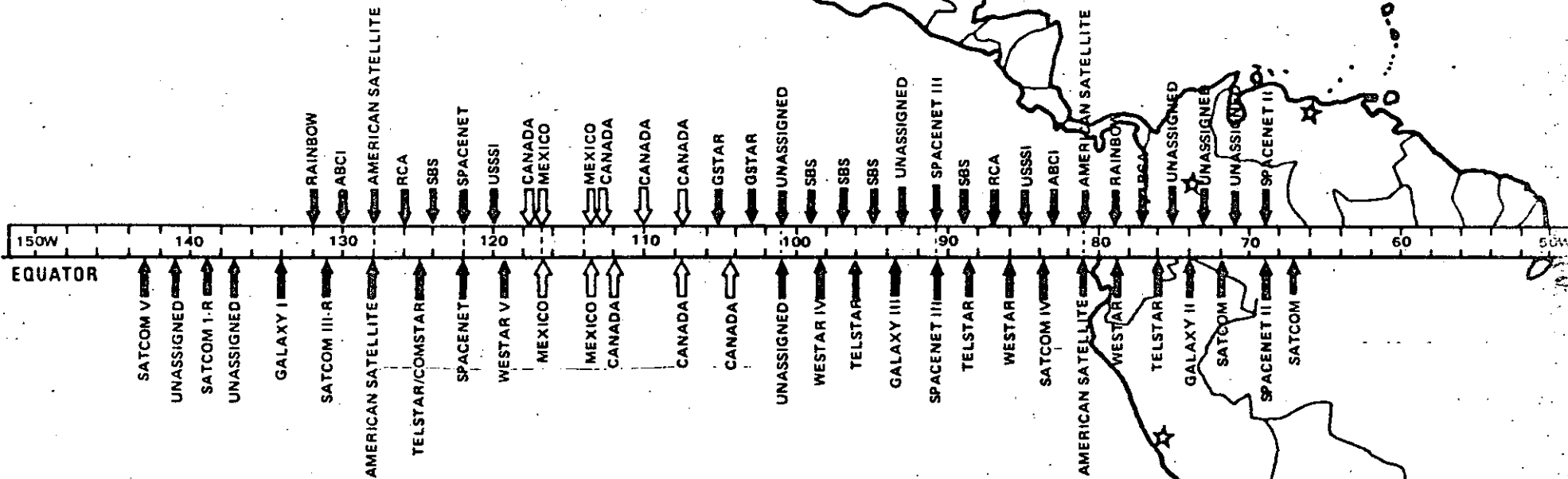
HUGHES

HUGHES AIRCRAFT COMPANY
SPACE AND COMMUNICATIONS GROUP
EL SEGUNDO, CALIFORNIA

LEGEND:

↓ USA ↓ FOREIGN

K-BAND



C-BAND

FCC DOMESTIC ALLOCATIONS (50°W—150°W)

APRIL 26, 1983

826787-2

DOMESTIC SATELLITE SUMMARY (AS OF FEB 1983)

SATELLITE PROGRAM, LAUNCH DATE LONGITUDE

	1	2	3	4	5	6	7	8	9	10	11	12	13	14
WESTERN UNION	WESTAR 1 4/73 127°	WESTAR 2 12/73 119°	WESTAR 3 6/79 98.5°	WESTAR 4 2/82 129°	WESTAR 5 6/82 119.5°	WESTAR 6 12/83 85°	WESTAR 7 8/84 78.5°	WESTAR 7* 20/85 ** X	WESTAR 8* 20/85 ** X	WESTAR K1* 1985 ** X	WESTAR K2* 1985 ** X	WESTAR K3* 1986 ** X		
	C	C	C	C	C	C	C	C	C	C	C	C	C	C
RCA	SATCOM 1 12/72 122°	SATCOM 2 3/76 119°	SATCOM 3 12/79 124°	SATCOM 3R 11/81 131°	SATCOM 4 1/82 83.5°	SATCOM 5 10/82 143°	SATCOM 1R 3/83 136°	SATCOM 2R 12/83 72°	SATCOM 6 5/85 67°	SATCOM 7* 10/84	SATCOM K1* 5/85 126°	SATCOM K2* 5/86 87°	SATCOM K3* 6/87 **	SATCOM K4*
CANADA TELESAT	ANIK A-1 11/72	ANIK A-2 4/73	ANIK A-3 5/75 114°	ANIK D-1 8/82 104.5°	ANIK D-2 10/85 111.5°	ANIK B 12/78 103°	ANIK C-1 11/82 112.5°	ANIK C-2 4/83 117.5°	ANIK C-3 4/84 108°					
COMSAT GENERAL	COMSTAR D1 5/73	COMSTAR D2 5/73	COMSTAR D3 5/78 87°	COMSTAR D4 7/81 125°										
SBS	SBS 1 11/83 100°	SBS 2 9/83 97°	SBS 3 11/85 95°	SBS 4 8/84 124°	SBS 5 4/85 89°									
HUGHES COMM (INC)	GALAXY 1 6/80 134°	GALAXY 2 9/83 74°	GALAXY 3 7/84 93.5°											
SPCC	SPACENET 1 2/84 122°	SPACENET 2 7/84 69°	SPACENET 3 7/85 91°	SPACENET 4* 9/85 **										
OTE SATELLITE	GSTAR 1 4/84 103°	GSTAR 2 9/84 105°	GSTAR 3 11/85 ** X	GSTAR 4* 11/85 X										
AT&T	TELSTAR 3A 7/83 125°	TELSTAR 3B 5/84 96°	TELSTAR 3C 8/84 88.5°	TELSTAR 3D 5/85 76°										
USSR	USAT 1* 1985 120°	USAT 2* 9/85 85°	USAT 3*											
AMERICAN SATELLITE	ASC 1* 10/86 128°	ASC 2* 3/86 81°	ASC 3* 2/87											
ADVANCED BUSINESS	ABC 1* 1986 130°	ABC 2* 1986 83°	ABC 3*											
ARTHUR V PALMER	DCBS* ** X 30/20/14/12 GHz	DCTS* ** X 30/20/14/12 GHz UHF/VHF	MGP* ** X 30/20/14/12 GHz + All lower bands											
BRAZIL	SBS 1 12/84 80°	SBS 2 3/85 85°												
MEXICO	MORELOS 9/85 116.5°	MORELOS 5/86 113.5°												
FORD	FASSC 1* 6/82 X 83-83°W	FASSC 2* 7/87 X 119-136°W	FASSC 3* X											
INTELSAT IV (LEASES)	F1 5/75 53.0°													
RAINBOW	RBI 1* 1985 132°	RBI 2* 1986 78°	RBI 3*											
CABLESAT GENERAL	CGC 1* 1986 ** X	CGC 2* 1986 ** X	CGC 3* X											

NEW FCC ALLOCATIONS (APRIL 1983) ARE IN RED
SATELLITE NUMBER IN EACH SERIES IS NOT NECESSARILY
MATCHED TO ORBITAL LOCATION

NOTES

- Satellites presently in operation.
- Out of service.
- △ Launch failure
- ▲ Applications propose an evolution toward a "Large Space Platform," drawing heavily on NASA's 20/30 GHz program.
- * Pending application for construction permit.
- ** Pending application for launch authority.
- C Satellite operates in the 6/4 GHz bands.
- K Satellite operates in the 14/12 GHz bands.
- H Satellite operates in both 6/4 and 14/12 GHz bands, (Hybrid)
- X Applications received after FCC processing order of May 18, 1982.

TDRS WEST 171°W	TDRS 79°W and 91°W	COLOMBIA	SATCOL 1A	SATCOL 1B	SATCOL H
			75.4°	75.0°	
TDRS EAST 41°W					
TDRS 3/84 91°	TDRS 6/84 79°				
H	H				

814

828

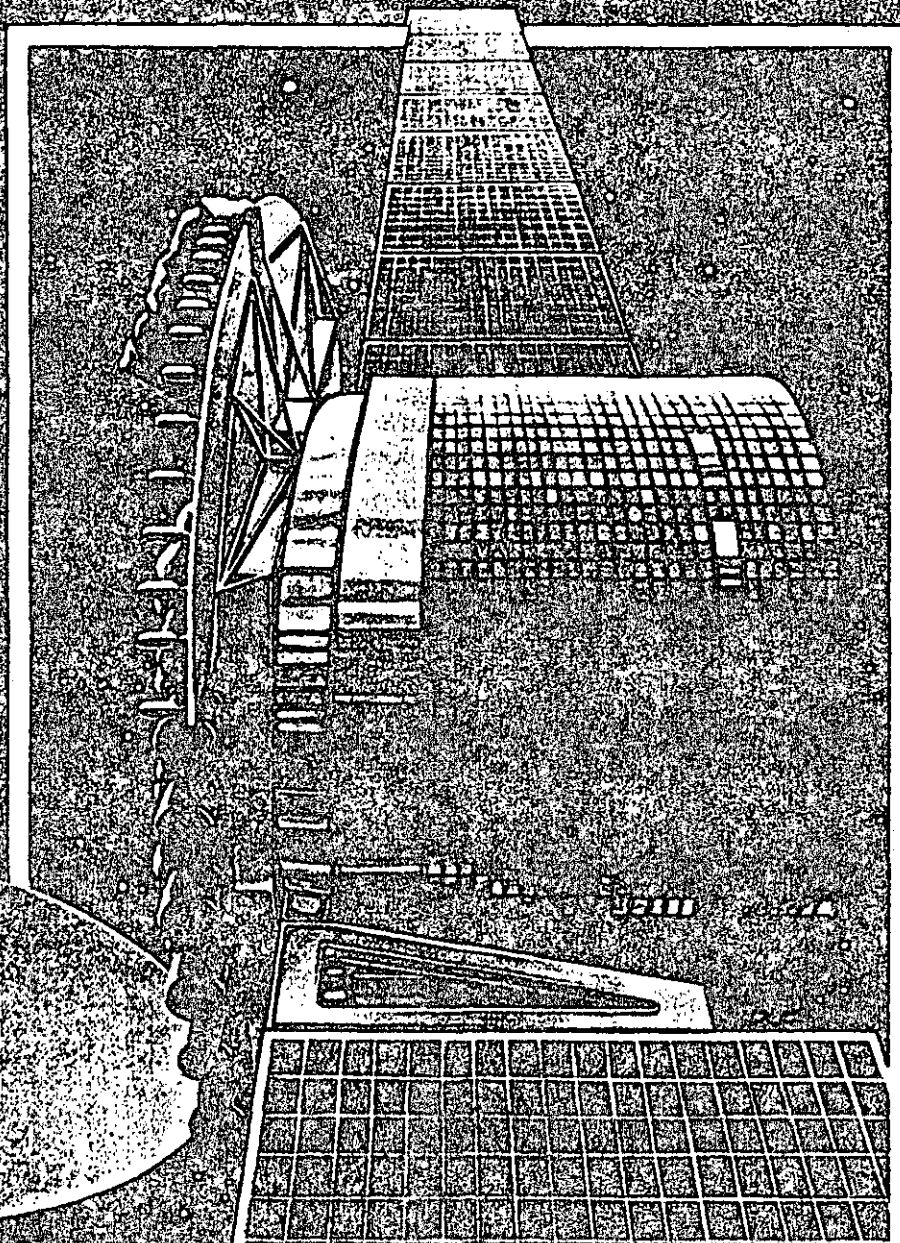
7. SISTEMAS FUTUROS Y TENDENCIAS

401

La literatura actual relacionada con la descripción de los futuros sistemas de satélites, su tecnología y sus aplicaciones, es muy amplia. A continuación se anexan copias de documentos que de una manera muy clara explican estos avances, mismos que son comentados en el curso.

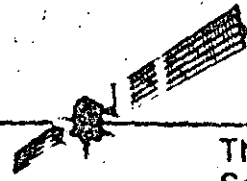
Satellite Communications

Notebook



816

This issue is a compilation of the Satellite Notebook series since it began in 1981, 39 installments in all.



The International Magazine for the
Satellite Communications Industry
Since 1977

Table of Contents

Notebook #	Page #	Notebook #	Page #
1	— An outline of Satellite Business Systems (SBS), its goals and objectives	18	— GTE Satellite Corp.'s high power GSTAR satellites 25
2	— Specifications for Comsat's STC broadcasting satellite and its applications	19	— Glossary of satellite industry terms 26
3	— The upgraded Satcoms: III R & IV	20	— Walter Morgan on Arabsat, the Arab Satellite Communications Organization
4	— The nine-spacecraft Intelsat V series	21	— Profile of Telstar 3 28
5	— The Fleet Satellite Communications System operated by the U.S. Navy	22	— Western Union's proposed 14/12 GHz satellite systems. 29
6	— Comstar, AT&T's domestic satellites leased from Comsat General Corporation	23	— A description of the Tracking and Data Relay Satellite System (TDRSS) owned by Spacecom
7	— An examination of Indonesia's Palapa system	24	— Walter Morgan's profile of the mobile maritime system. 31
8	— Western Union's Westar system outlined	25	— Unisat, the satellite with the changing names and combination of services
9	— Walter Morgan explains the Hughes Galaxy satellites and how they penetrated the CATV market	26	— Intelsat's return to a spin-stabilized spacecraft
10	— Japan's Medium Capacity Communications Satellite for Experimental Purposes is explained. CS (Sakura) and CS-2a & 2b	27	— An outline of the American Satellite Company's system. 35
11	— The Tiros/NOAA multi-mission sensing satellites for weather forecasting	28	— The three-satellite Australian national communication satellite system
12	— Leasat analyzed as a future replacement for the Fleet Satcom system	29	— Morelos, the Mexican Communications System
13	— Initial European DBS satellites and policy matters affecting their performance	30	— A table of all geostationary satellite locations
14	— Spacenet and SP Communications Corp.'s increasing involvement in the industry	31	— Eutelsat 1, a first-generation European communications satellite
15	— The military's new generation of communications satellites, DSCS-III	32	— A special edition on the future of the industry in light of the new domestic satellite findings
16	— The three-satellite Anik-C series owned by Telesat Canada	33	— RCA's 14/12 GHz medium power satellites
17	— Japan's direct broadcasting satellites, BSI (Yuri), BS-2a & BS-2b	34	— M-Sat, the joint U.S.-Canada mobile satellite project detailed
		35	— An examination of Tele-X and Nordsat
		36	— Telecom-1, French communications satellite
		37	— Insat, India's communications, broadcasting and meteorological satellites
		38	— The story of Insat continues with Insat-1B and Insat-1C. 50
		39	— Description of the Brazil SBTS A1 & A2 51

Dear Reader:

Since 1981, Walter L. Morgan of the Communications Center of Clarksburg, has been writing the Satellite Notebook series for Satellite Communications magazine. It has grown, and continues to be one of the most popular features of the magazine. The series has covered both domestic and international satellites, organizations, their functions, technical specifications and policies. All 39 installments of Morgan's writings are included in this issue. It will provide a handy reference for anyone involved in the satellite communications industry. All articles are presented in their original order. None have been updated so the reader may gain an historical perspective of the satellite industry through the writings of one of the industry's most respected authorities.

SBS-1

By Walter L. Morgan

Satellite Business Systems (SBS) was established in Dec., 1975 as a joint venture of Comsat General, IBM and Aetna Life and Casualty. The SBS system is intended to provide an integrated, all digital, interference free transmission for telephone, computer, teleconferencing and telemail services. The total capacity of the satellite may be as high as 480 Mb/s or 10 million words.

The satellite diameter is 2.16 m. The height varies from 2.82 m in the stowed condition to 6.6 m when the solar panels and antenna are deployed. The satellites have an on-orbit mass of 555 kilograms (1222 lbs). The dual-drum solar array generates 914 watts.

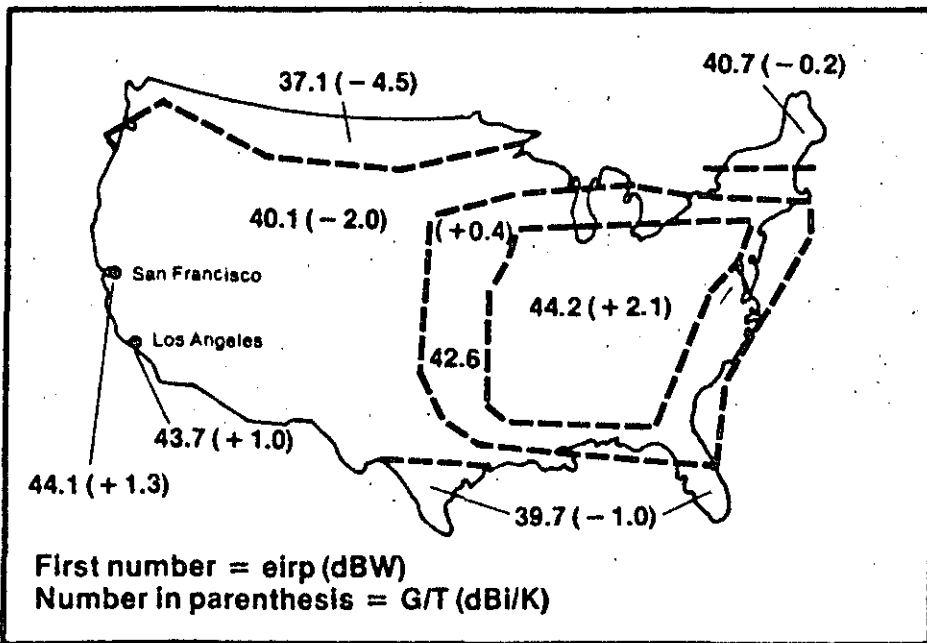
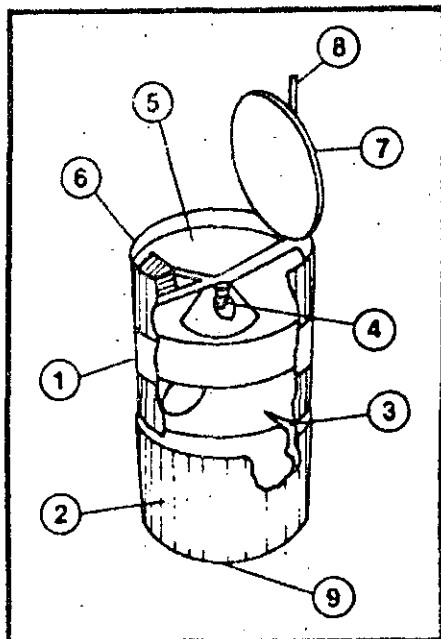
The two solar arrays (1 and 2) are telescoped for launch. The position of the lower array (2) is actively controlled (3) as part of the nutation control. The outer array (1) supplies power during the transfer orbit. The entire satellite is spin stabilized with a despun antenna. The despun mechanism (4) has a two axis motion. The first is to remove the spin of the satellite, and the second is to remove any remaining nutation, bearing groan, or other instabilities. An arm (5) supports the feeds (6) and a dual surface reflector (7) and the TT&C antenna (8).

The antenna (7) is a shaped aperture device, 183 cm in diameter. The two surfaces are separated by polarization for transmitting and receiving. The resulting antenna beams (see lower figure) are shaped to optimize the power and sensitivity of the satellite on the industrial areas of the United States. The TT&C antenna (8) operates at both 4 & 6 GHz (for the transfer orbit) and 12 & 14 GHz (for on orbit use). The apogee kick motor (9) is a Star 48. The initial two satellites use the Thor Delta 3920 and the PAM-D perigee assist module. These satellites have a fuel lifetime of approximately seven years. The third satellite will be launched using the shuttle (STS) and the PAM-D

The satellite uses a single polarization and therefore requires only one of the four receivers carried on board. Ferrite switches at the antenna output select the receiver. The receivers have a noise figure of 4.3 dB. There are sixteen 20 watt TWTA's carried for the ten transponder channels. The satellite's performance is as shown. Each of the transponders has a 43 MHz bandwidth.

The operating frequencies (14.0-14.5 GHz and 11.7-12.2 GHz) permit earth stations to be located on the customer's premises using 5.5 to 7.7 meter antennas. This band permits nearly unlimited locations for the earth stations. The stations use a 300K LNAs and a pair of 250 W TWTAs. With forward error control, the bit error rate is 1×10^{-7} . □

The satellite uses a single polariza-



SUMMARY

- Operator: Satellite Business Systems
- Launches: 1980, 1981, 1987
- Satellite Class: HS-376
- TT&C Stations: Castle Rock, Colo. & Clarksburg, Md.
- Control Center: McLean, Va.
- Orbit Locations: 100 W (SBS-1) 97 & 94 W (SBS-2 & -3).

In his second installment of *Satellite Notebook*, Walter Morgan, our consulting editor, details the specifications for Comsat's STC Broadcasting Satellite and its' applications.

We'd like to welcome Walter to a regular monthly berth at *Satellite Communications Magazine*, keeping us abreast of the latest in satellite hardware.

By *Walter L. Morgan*
Consulting Editor
Communications Center of Clarksburg

The Satellite Television Corporation (STC) is a subsidiary of the Communications Satellite Corporation (Comsat) that was established to own and operate direct broadcast satellites for providing multiple television channels directly to the homes of subscribers in the United States.

These satellites will operate at frequencies in the 12.2-12.7-GHz band using time-zone-shaped beams to operate into small home antennas. All 50 states are covered in the application filed with the FCC in 1980 but only the Eastern Service Area (ESA) would be covered by an initial FCC authorization for experimental service with one active and one spare satellite.

Eventually STC plans to have four active (one for each time zone) plus two spare satellites on orbit. Hawaii

and Alaska are covered by the Pacific Service Area (PSA) satellite that also covers the Western-most part of the U.S.A. The ESA and CSA satellites are of one design (any satellite being capable of serving either time zone) while the MSA and PSA satellites are of a second design. All satellites operate on a common set of three channel frequencies. Orthogonal circular polarizations are used to separate the adjacent (and in most cases overlapping) beams. A different orbit location is used for each service area satellite, thus both polarization and a 20-degree angular separation provide isolation at the earth station.

Three TV channels will be available. There will be a diversity of program material to be offered including specialty (narrowcasting) programs. Each channel will have two 13-kHz audio

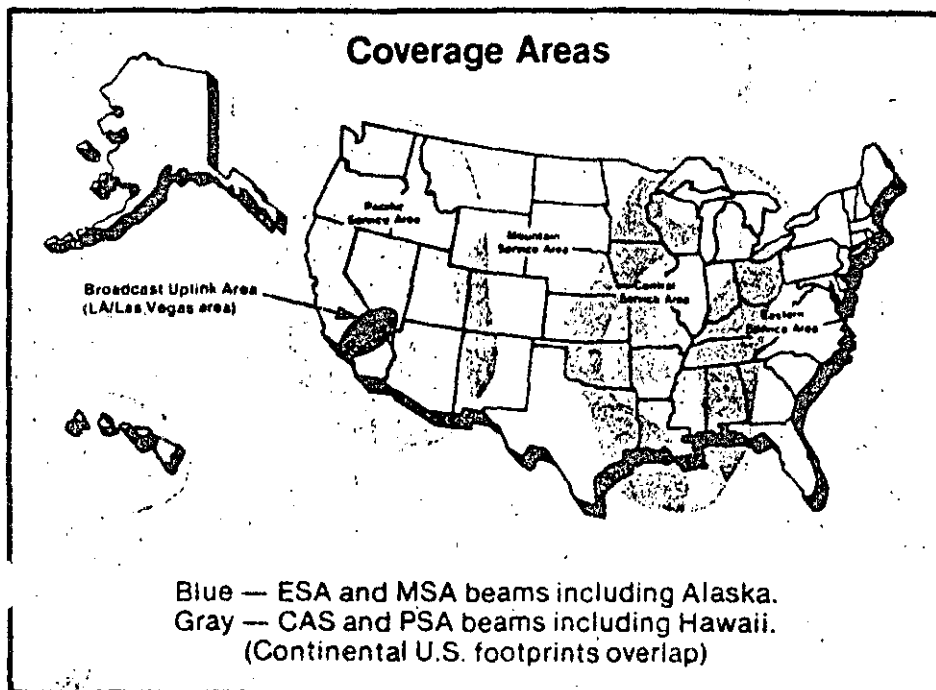
channels (for a second language or stereo), closed captioning, teletext and eventually a high definition television (HDTV) service at 1000 to 1500 lines. The HDTV would be provided by switching transponders two and three from the normal 16-MHz bandwidth to 28 or 100 MHz via on-board equipment.

The satellite described in the filing has a 2.9m antenna (45 kg), two 1.5 x 7m solar arrays which generate 2 kW initially and 1.7 kW at end of life (7 years). The satellite mass is estimated at 650 kg (1433 lbm) on orbit. No TV is provided during the eclipse. All active units are fully redundant.

The home earth station uses a 75 cm (2 1/2') antenna and a 4.5 dB NF receiver ($G/T_e = +8.8$ dB/K). The satellite eirp ranges between 55.1 and 58.2 dBW. The coverage figures are for 57 dBW where the 75 cm antenna provides a clear-sky margin of 5.9 dB. 60 and 90 cm antennas may also be used in some areas.

The uplink signals come from the Los Angeles-Las Vegas area.

The television signals will be scrambled. The audio will be digitized and combined with a descramble code.



Summary

Operator: Sat. TV Corp. (Comsat)
Approx. launch date: 1984 STS/
PAM-D or Ariane III with SYLDA
(dual launch).
Lifetime: 7 years.
Transponders: 3 @ 17/12 GHz 200
WTWTAs.
TV Picture: (99 percent) 42 dB
Scrambled FM-TV 16 MHz.
Locations: 115, 135, 155, 175W
Spares: 115.05 & 174.95W.

Satcom III-R & IV

By Walter L. Morgan
Consulting Editor
Communications Center of Clarksburg

RCA American Communications, Inc. plans to launch two satellites this year. These satellites (Satcom III-R and IV) are upgraded versions of the first generation Satcoms. The first generation consisted of three satellites (I, II, III) of 24 transponders each, using 5-watt tubes and no spares. Satcom III-R and IV will incorporate twenty 5-watt and four 8.5-watt TWTAs. Spare units are provided.

The second generation RCA Satcoms (V and VI, to be launched in 1982 and 1983) will use 8.5-watt solid state power amplifiers. Four of the 28 SSPAs aboard will be spares.

Satcom III-R replaces the original Satcom III (which was launched in 1979 and lost during insertion into the geosynchronous orbit) and will become the Cablenet 1 satellite. It will relieve traffic from Satcom I which is presently the primary cable TV satellite.

The loss of Satcom III led to the filing of a \$77 million claim for loss of the satellite, its launch vehicle, and the initial revenue. This insurance payment enabled RCA to lease transponders on Comstar D-2 as an interim measure, which provided some capacity for expanded services to the cable industry.

Satcom IV will be placed at 83 degrees west, and will also be used for CATV by transferring traffic from the RCA leased transponders on Comstar

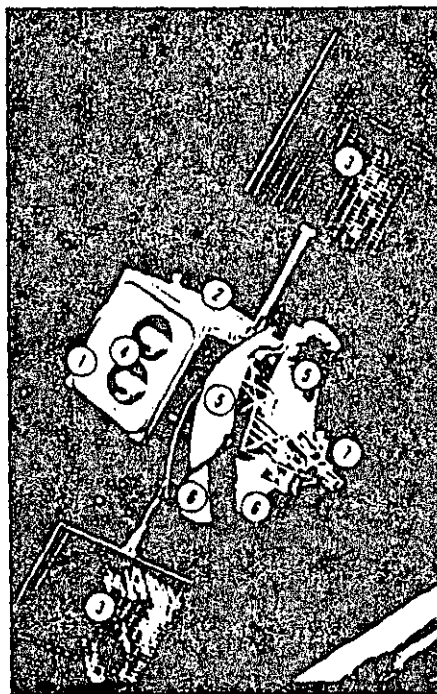


Figure 1.

D-2. Satcom III-R will be at 131 degrees west.

At the beginning of life in geosynchronous orbit, the satellite weighs approximately 462 kg (1019 lbm). The body (Figure 1, #1) is 5.3 by 4.1 by 4.1 meters. The north and south surfaces (2) are used for thermal control. As in the previous satellites, each solar array (3) consists of two foldout panels. When deployed, these panels measure eleven meters, tip to tip, and are not aligned with the

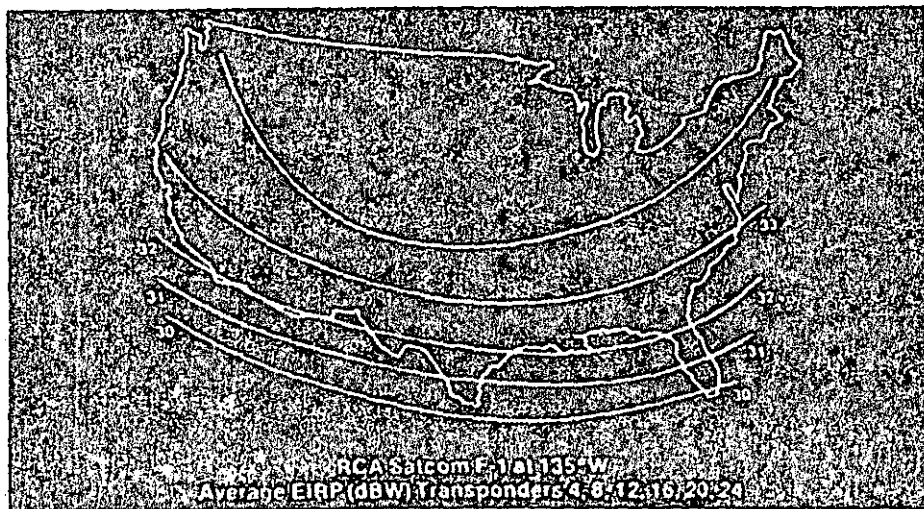
center of mass of the satellite. Hence, to overcome the solar torques, magnetic torquing is used with coils on a solar array. This technique, pioneered on the Tiros satellites, requires no onboard fuel.

Hydrazine tanks (4) and associated thruster systems are used for station-keeping and attitude control. This mid-generation class of satellite contains higher capacity batteries than the first generation. Also, the end-of-life power capability of a solar array is approximately 550 watts. A three-axis stabilization system is used.

The antenna system consists of two pairs of reflectors, one placed atop the other. The top reflector (5) contains a grid for reflecting one polarization. The orthogonal polarization is passed through the top reflector (5) and reflected by the bottom grid (6). The feed horns (7) are offset. Four different coverage patterns result in coverage of all fifty states, with eirp levels in the range of 32 to 34 dBW at the edge of the contiguous 48 states. The uplink G/T is approximately -6 dB/K under the worst condition. Each transponder has a nominal bandwidth of 34 MHz for a total of 816 MHz on the satellites.

These satellites will be launched on a Thor Delta 3910, with a perigee assist module (PAM-D). Future generations will use the space-transportation system (Shuttle) to reach the low earth orbit, from which a transfer stage will place the satellite onto the transfer orbit. At that time the apogee kick motor is fired to attain the geosynchronous orbit.

Satcom III-R and IV will operate at 5.925/6.425 GHz for the uplink and at 3.7/4.2 for the downlink, and are fully compatible with the present CATV and Alascom earth stations. □



Summary

Operator: RCA American Communications, Inc.

Launches: 1981 (2).

TT&C Stations: Vernon Valley, N.J. and Moorpark (South Mountain), Calif.

Control Center: Vernon Valley, N.J.
Orbit Locations: 131 west (Satcom III-R) and 83 west (Satcom IV).

Also Known as: Satcom D&E.

Intelsat V

By Walter L. Morgan
 Consulting Editor
 Communications Center of Clarksburg

The Intelsat V series consists of nine spacecraft, five of which will be fitted with a maritime communications subsystem (MCS), operating at 1.6/1.5 GHz. Assembled by Ford Aerospace, the satellite is truly international, containing major assemblies from the US, France, UK, Italy, West Germany and Japan. Valued at \$34 million, the satellite is part of a \$60 million Intelsat investment. Earth stations are owned by Intelsat member countries.

The Intelsat organization consists of 106 countries, and its network provides about two-thirds of the transoceanic telephone circuits, and most of the world's TV connections. Intelsat also provides domsat services to 16 countries, and each Intelsat V can simultaneously relay up to 12,000 full voice circuits and two TV channels.

Intelsat V-F2 was launched Dec. 6, 1980, and will be the Atlantic Ocean spare. The next launch (V-F1) is planned for mid-1981, and is to be the Atlantic primary. The first five satellites will be launched aboard the Atlas-Centaur, while the next three will ride the Ariane, from Kourou, French Guiana.

Early test results have shown that the communications packages are performing at better-than-specified values. First use of the 14/11 GHz band was a teleconference between Genoa, Italy, and Clarksburg, Md., in March. It was highly successful.

The Intelsat V has a tip-to-tip solar array span of 15.6 meters, and it's panels produce 1,241 watts after seven years. The body is 6.4 meters tall, and at launch its mass is 1,946 kg (4,290 lbm). Mass in orbit is 1,041 kg (2,296 lbm).

Pictured on the cover of the April, 1981 *Satellite Communications* magazine, the spacecraft operates in the 4,6,11 and 14 GHz bands. (See Figure 1). Transponders have varying bandwidths, between 36 and 241 MHz. Spot beams operate at 14/11 GHz, and have edge-coverage e.i.r.p.s of 38 dBw (east) and 41.7 dBw (west). All other beams are at 6/4 GHz. Shaped and global beams cover the Intelsat earth station network (Figure 2). The 27 transponders have a total bandwidth of 2137 MHz. Other specifica-

tions are listed in the "Satellite Performance Reference Chart" in the March, 1981 issue.

Intelsat V is the sixth generation, as IV-A was the fifth. Ford has a contract to build at least three of the V-A series. A request for proposals for the Intelsat VI series has been issued.

Summary

Operator: Intelsat.
 Launches: 1980-81 82.
 Control Center: Washington, D.C.
 Orbit Locations: Over the Atlantic, Pacific and Indian Oceans.
 Lifetime: 7 years.

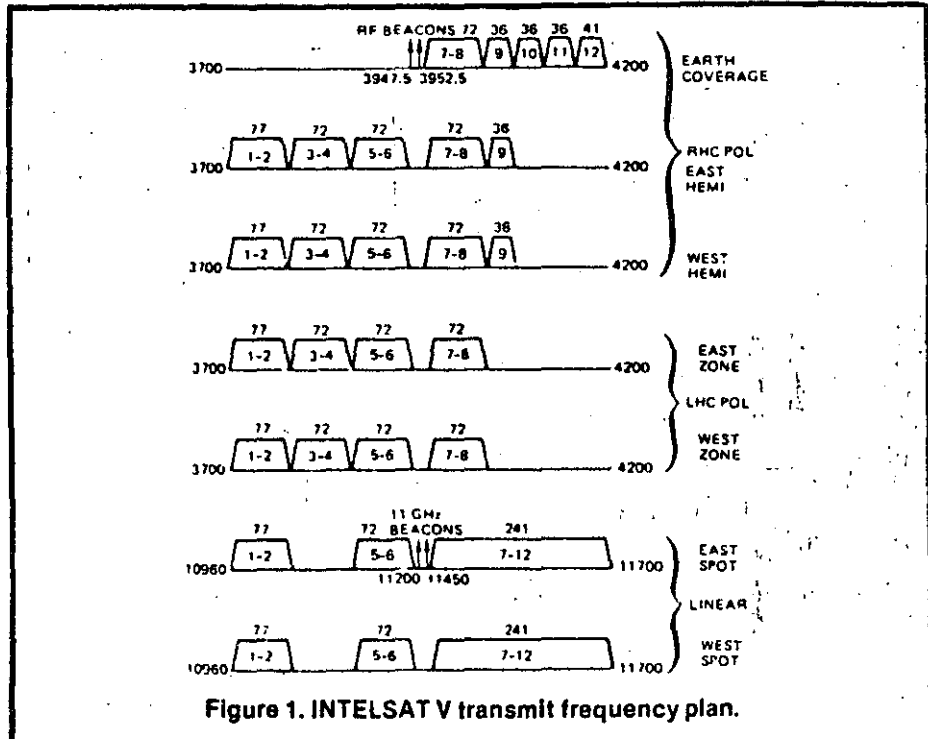


Figure 1. INTELSAT V transmit frequency plan.

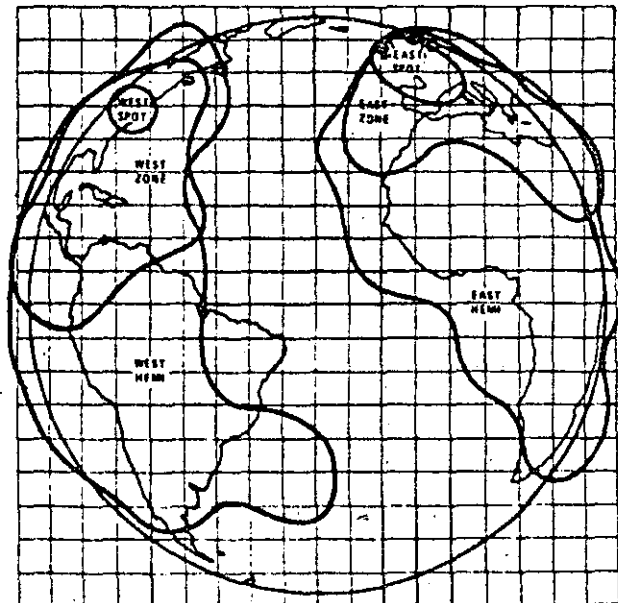


Figure 2. INTELSAT V Atlantic Ocean coverages.

Fitsatcom

By Walter L. Morgan
Consulting Editor
Communications Center of Clarksburg

The U.S. Navy's space program includes a communications satellite series known as the Fleet Satellite Communications System. Also referred to as FleetSatCom or Fitsatcom, it is a government satellite that operates at UHF or SHF, providing the Navy worldwide communications to its ships, submarines and shore stations. A portion of these satellites is shared by the U.S. Air Force as part of the AFSatCom-I system which provides services to aircraft, earth stations and the Commanders-in-Chief.

The AFSatCom-I system uses UHF capacity on several satellite systems, including LES, GPS, SDS and Fitsatcom. The LES-5 and -6 and TacSatCom were earlier military UHF satellites.

Space Segment

The first Fitsatcom was launched on February 9, 1978. The four satellites in operation provide global coverage (except at the polar regions). The fifth is to be launched in August, 1981 as an on-orbit spare. For mobile applications (where a tracking antenna is needed) some extension of the nominal five-year lifetime is possible by relaxing the three degree inclination requirement. The east/west stationkeeping goal is plus or minus one degree.

Fitsatcom is unique in many ways. First, it employs a large helical receive antenna which is deployed in orbit. The stabilization system (goals: 0.2 degrees in pitch and roll and one degree in yaw) uses a body-fixed,

momentum-biased reaction wheel. The body is hexagonal in cross-section, with a width of 2.3 meters and a height of 1.2 meters. Deployed antennas give the spacecraft an overall height of 6.6 meters, and the solar array measures 13.2 meters, tip-to-tip. Each panel is approximately 9 by 13 feet, and end of life power for the satellite is 1260 watts. Using on-board batteries, the satellite can operate throughout an eclipse.

The body has two sections. The first holds the communications antennas, receivers, frequency synthesizers, decoders, filters, processors, limiters and transmitters. The other contains housekeeping functions: fuel, power, solar array drives, stationkeeping and altitude controls, and TT&C.

The satellites have been designed to resist physical attack, nuclear radiation and jamming. This makes them heavier than other narrow-band satellites. End-to-end encryption is available, and on-board processors may be used for certain channels.

Communications

This subsystem features an 18-turn helical antenna which receives the circularly polarized signals in the 292-318 MHz band. The G/T is -16.7 dB/K. The spectrum is divided into 23 channels with bandwidths of 5, 25 and 500 kHz (see table 1). The 10 solid-state transmitters have full-power output ratings of 33 to 46 watts.

When deployed, the 4.9-meter para-



bolic mesh reflector antenna is used for the 243-270 MHz downlinks. It is the largest deployable antenna carried into space on a routine basis.

A horn antenna is provided at 7/8 GHz, with full visible earth coverage at both UHF and SHF. The fleet broadcast channel can be addressed at 8 GHz, and there is a beacon in the 7 GHz band as well.

Because of the close proximity of the multiple channels and the receive-transmit frequencies, problems were encountered with intermodulation distortion (IM) products. Originally only a single UHF parabolic antenna was planned. The flight units use separate antennas.

Launch

The Atlas-Centaur is used to launch Fitsatcom, and an apogee kick motor enables it to reach geosynchronous orbit. At launch the satellite's mass is 1876 kg (4136 lbm). On-orbit mass is 1005 kg (2216 lbm). The satellite is manufactured by the Space Systems Group of TRW, under contract from the Air Force's Space Division (formerly SAMSO).

Just as Fitsatcom replaced the Gap-sat service (the UHF portion of Marisat) the Leasat will eventually replace the retiring Fitsatcoms.

Table 1. Fleetsatcom Channellization

Quantity	Function	User	Bwth kHz each	eirp dBW	rate bits/sec
1	Fleet Broadcast	USN	25	26	1200
9	Fleet Relay	USN	25	26-28	1200-32,000
12	AFSatCom	USAF	5	16.5	75
1	Wideband	USAF	500	27	Various

Summary:

Operator: U.S. Dept. of Defense
Launches: 1978, 79, 79, 80, 81
Control Center: Sunnyvale, Calif.
Locations: 100W, 72.5E, 23W, 172E, 93W
See also *Satellite Communications*:
March 1978; January, 1979; June, 1980.

Comstar

By Walter L. Morgan
Consulting Editor
Communications Center of Clarksburg

These satellites are leased by the Comsat General Corporation to AT&T for domestic services. The total revenues to Comsat have been about \$200 million to date. A total of 300 transponder-years have been provided.

The Comstar satellite system is now complete with the launch of the fourth satellite in the series, earlier this year. The first Comstar was launched in May 1976 about 32 months after the contract was signed with Hughes Aircraft Co. The four satellites are similar to Intelsat IV-A and provide full national coverage at 6/4-GHz.

Comstar D-2 has provided replacement transponders to RCA. Other transponders on this satellite are now being offered for lease by AT&T for \$1,664,700 per transponder-year (including earth station services).

The actual earth station facilities are provided by AT&T, GTE Satellite Corp. and a unit of ITT (in Puerto Rico).

Each earth station uses two or more 30 to 32 meter antennas for trunk telephony service. A typical G/T of 42 dB/K is achieved using 17K LNAs. The AT&T stations use a 3 kW klystron or a 1 kW TWTAs for the up-link power amplifier.

Each satellite has a capacity of about 1500 half circuits per transponder. There are 24 transponders

(at 34-MHz each) in the communications subsystem.

Unlike most domestic satellites, the received and transmitted polarizations are identical for any one transponder. Two rectangular reflectors with polarized screens are used to produce the vertical and horizontal frequency reuse signals. The G/T is -9 dB/K and the eirp is 33-34 dBW for the worst case over the contiguous US.

The Atlas-Centaur was used to launch the Comstars. On orbit their mass is about 864 kg (1900 lbm). The satellite body has a diameter of 2.4m and a height of 6.1m. The end of life power for the satellite is 600 Watts.

The aging Comstar D-1 and D-2 satellites have been co-located at 95 West longitude where they are being operated as though they were a single

satellite, thus lengthening the life of both TWTAs and batteries. As a further means of extending the battery capabilities some of the 24 TWTAs were turned off during the eclipse seasons early in life when traffic allowed.

The Comstar series also carry beacons at 18 and 28-GHz for measuring the anticipated attenuation in these future satellite communications bands. These transmitters were provided by Comsat's Clarksburg laboratories and operate as long as the solar array generates excess power.

The Comstar satellites will eventually be replaced by AT&T's Telstar-3 and General Telephone's GSTAR series of satellites.

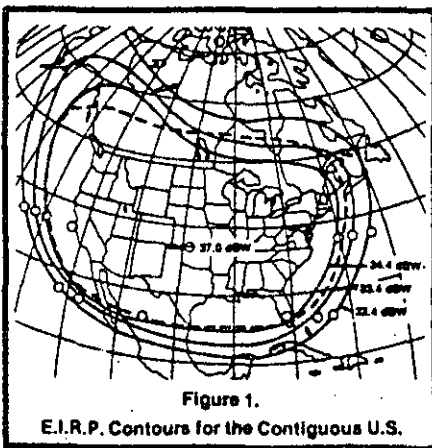


Figure 1.

E.I.R.P. Contours for the Contiguous U.S.

Summary

Owner: Comsat General Corp.
 Operators: AT&T & GT&E
 Launches: 1976, 76, 78, 81
 Orbit locations: 95, 95, 87, & 127.25W
 Lifetime: 7 years
 Control Center: Washington, D.C.
 TT & C locations: Southbury, Conn.,
 Santa Paula, Calif.

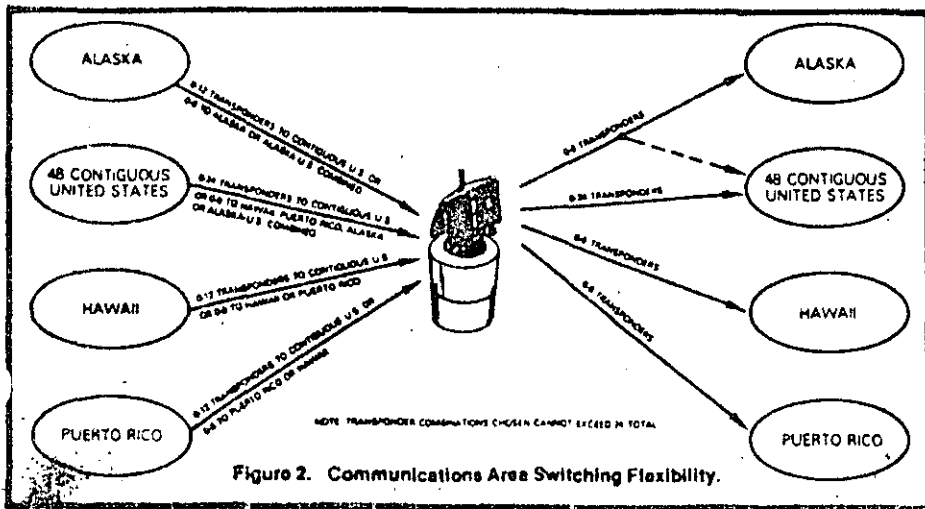
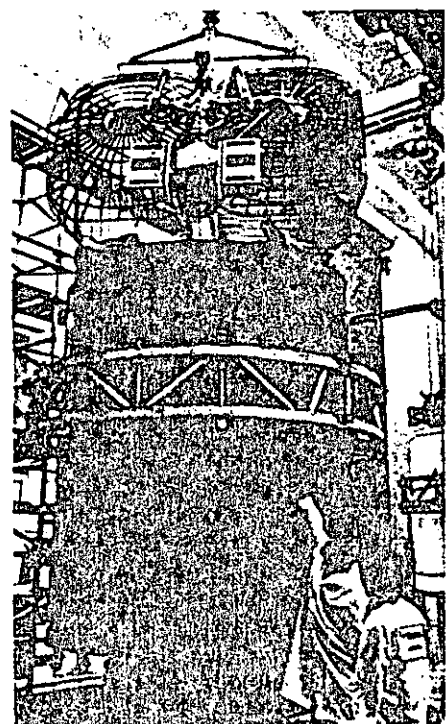


Figure 2. Communications Area Switching Flexibility.



Comstar

Palapa

By Walter L. Morgan
 Consulting Editor
 Communications Center of Clarksburg

"Palapa" is a fruit mentioned in an oath taken by a 13th Century Indonesian prime minister. Today, the word stands for Indonesian national unity, an appropriate title for the satellite communications system of that country.

The Palapa satellite system will be using two series of satellites in the mid-1980s. The first, Palapa-A, consists of two satellites, launched in 1976 and '77, using the Hughes HS-333 satellite design. This series was originally intended for national service to Indonesia's 120 million people, who populate 5000 islands, covering a span of 3000 miles. Television, radio, telephone, telegraph and government traffic is carried. As well, several transponders have been leased to the Philippines for their internal use.

The Palapa-B series will utilize the larger Hughes HS-376 family of satellites. Service will be provided throughout the entire ASEAN (Association of South East Asian Nations) membership, thus providing regional coverage. Perusahaan Umum Telekomunikasi (PERUMTEL) is the Indonesian organization that has planned and operates the Palapa system of satellites and Indonesian earth stations.

The development of two series of satellites illustrate the rapid growth of telecommunications in this part of the world, and the rapid growth in satellite technology. The new satellites will have twice as many transponders (24 vs. 12), each with double the power. The edge of coverage e.i.r.p.s are 34 dBW (Indonesia), and 32 dBW (ASEAN). The uplink G/Ts are -5 and -7 dB/K respectively. One of the Palapa-B transponders will be used for regional TV among ASEAN members. This is a prime example of regional telecommunications cooperation.

The A series was launched aboard

the Delta launch vehicle. In keeping with the rapidly changing times, the B spacecraft may go up on the STS/PAM, or the Delta 3920/PAM. Both Palapa-B launches are scheduled for 1983 on the Shuttle.

The Palapa-B series will cost \$74.5 million (fixed price, including PAM but excluding the rest of the launch vehicle). Part of the expense is being underwritten by the Eximbank and U.S. Banks.

Master control center for Palapa is in Jakarta. There were 40 earth stations constructed for the original system, and additional stations are



being built, particularly small terminals of five meters or less. G/Ts will be 18 to 22 dB/K. Portions of these stations are being made in Indonesia, and at least 100 earth stations will be in use in the near future.

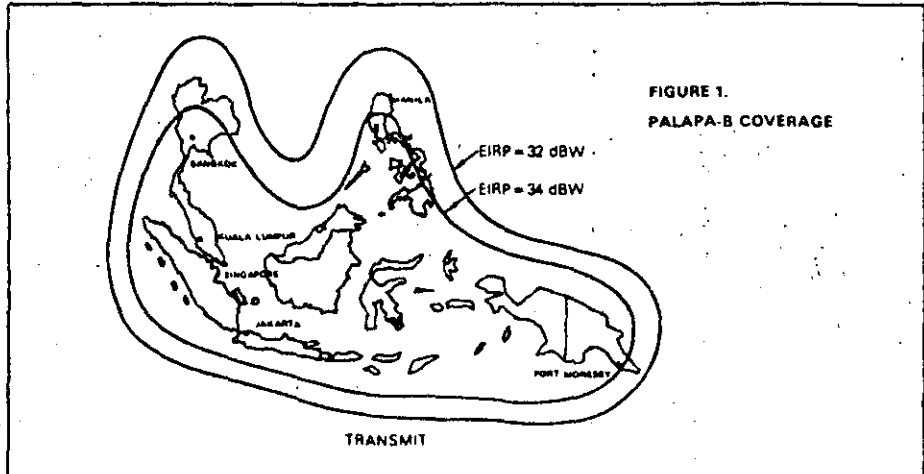


FIGURE 1.
 PALAPA-B COVERAGE

Table of Comparative Performance
 Summary

Parameter	Palapa-A	Palapa-B	Units
Transponders	12	24	
TWTAs	12	30	Tubes
Power/tube	5	10	Watts
eirp-Indonesia	32	34	dBW
- ASEAN	27	32	dBW
G/T-Indonesia	-7	-5	dB/K
Mass on orbit	294	638	kg
DC power (min.)	300	831	Watts
Satellites	2	2	
Locations	83 & 77	108, 113 & 118	E. Long.
Lifetime	7	8	Years

Westar

By Walter L. Morgan
 Consulting Editor
 Communications Center of Clarksburg

The original three Westar satellites will soon be joined by another three, and later by the Advanced Westar (AW) series. Very recently, a waiver was approved by the FCC which will permit Western Union to begin construction and arrange launch services for Westar VI. Two of these spacecraft will replace the seven year old Westars I and II.

The first three spacecraft (I-III) and Westars IV & V are to be 20 percent owned by the American Satellite Co. of Rockville, Md. (which is jointly owned by Continental Telephone of Atlanta, Ga. and Fairchild Industries of Germantown, Md.) and 80 percent by the Western Union Telegraph Co. of Upper Saddle River, N.J. The Advanced Westar satellites are owned by the Space Communications Company of Gaithersburg, Md. Spacecom is a joint venture of Western Union (50 percent), Fairchild Industries (25 percent), and Continental Telephone (25 percent).

The Westar satellite series has been used for domestic U.S. services. These include the distribution of radio programs, independent TV programming, and up to four simultaneous channels of the Public Broadcasting System (PBS) TV programs. The Western Union Telegraph Company uses them for connecting cities off its basic terrestrial microwave network for both telegraph and telephone services. The

satellites are an important element in its new Metro I long distance telephone service. The satellite has reduced WU's dependence upon the AT&T Long Lines and made new market entries possible.

Other users, such as Cylix, use the Westars for private and leased voice/data offerings. American Satellite Co. provides a full range of private line services, wideband data and government services via the Westar system.

Transponders have been made available both for lease and sale. All transponders on Westars I through V have been committed. Some on Westar VI have already been committed as well.

The original three satellites use the Hughes HS-333 spaceframe. Westars IV through VI are based on the HS-376 design. (See Satellite Notebooks 1 [SBS] and 7 [Palapa]).

Eventually one Advanced Westar (AW) satellite will be added plus a spare

satellite to be shared with the NASA TDRS. These are body-stabilized spacecraft being built by TRW for use in both the Advanced Westar and Tracking and Data Relay Satellite (TDRS) services. It is not intended that the spacecraft be used simultaneously for both services. The Advanced Westar operates at 6/4 and 14/12-GHz (see elsewhere in this issue for an application of 12 GHz. It may be described in a future Satellite Notebook when its fate and uses become clearer.

Of the 12 TWTAs in Westar I, II and III there are 10, 11 and 12 transponders still in use. During eclipse the HS-333 design permits 10 TWTAs to be powered in the later years.

Frequency reuse is employed on the Westar IV-VI and at 14/12-GHz on the Advanced Westar. The Westars I-III and the Advanced Westar antennas do not have sufficient polarization isolation to allow more than 12 transponders per orbit slot at 6/4 GHz.

Parameter	Westar	Advanced Westar
Owner	Western Union Telegraph Co.	Space Comm. Co.
Launch dates	1974, 74 & 79 1982, 82 & 84	1983
Satellite Class	HS-333 HS-376	TDRS
TT&C Stations	Glenwood, NJ	White Sands, NM
Orbit Locations	99, 123.5 & 95 W 99, 123 W & TBD	Spare TDRS/AW at 79W 91 W
Lifetimes (years)	7, 10	10
Transponders	12, 24	12 + 4
TWTA Power (W)	5, 7.5	5 (at 4-GHz)
BOL Mass (kg)	249, 585	2268
EOL Power (W)	282, 684	1700

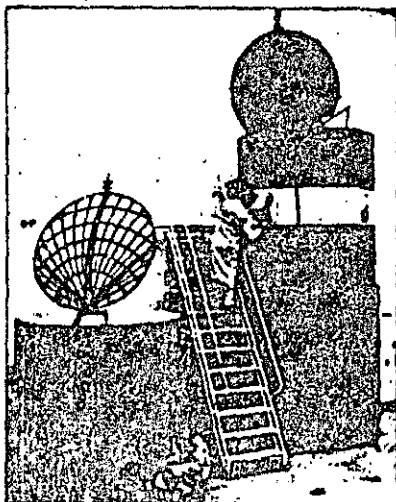


Figure 1. Westar I & IV

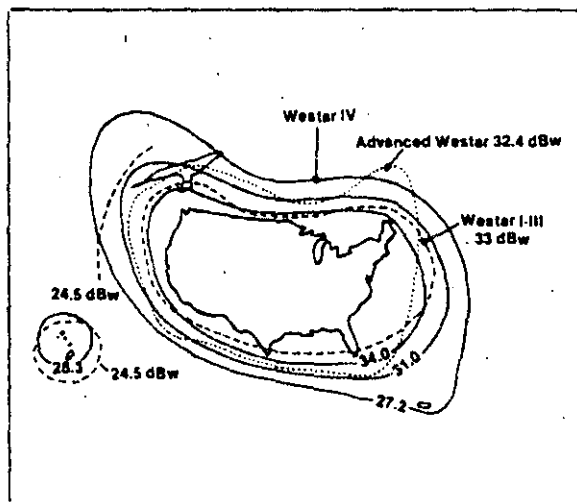


Figure 2. EIRP Coverage at 4 GHz

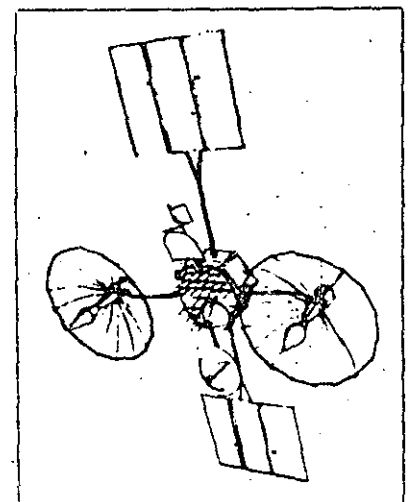


Figure 3. Advanced Westar

Galaxy

By Walter L. Morgan
Communications Center of Clarksburg

The renaming of Hughes Communications' two authorized 6/4 GHz satellites from HC-2 and HC-1 to Galaxy I and II, respectively, signaled much more than a cosmetic change. Soon the industry came to recognize the new Hughes subsidiary as a strong contender in the domestic satellite transponder marketplace.

In a well-timed and orchestrated thrust, Hughes Communications was able to cut to the very heart of the CATV satellite business, heretofore the sacred preserve of RCA's Satcoms. The initial coup was to conceive of a "shopping center" in orbit, filled with video goodies. What would be a more natural spot on the Geo orbit than 135° West, present home of Satcom I, towards which most CATV antennas now point? The FCC had assigned Hughes this slot when it reallocated orbit locations late last year (see *Satellite Communications*, January, 1981, page 17).

The first step was to activate a magnet that would attract other video programmers. The sale of six transponders to Time Inc.'s Home Box Office in mid-1981 got things off to a fast start. In a rapid string of sales, 16 of 18 primary transponders were sold

on Galaxy I (see figure 1). The primary transponders are those that have two levels of protection. One level uses a spare TWTA in each bank of four active transponders. The other level permits substitution of one of six reserve transponders. For the 18 primary transponders, there are six spare TWTA's, and six reserve transponders. Hughes' reserve transponders may be utilized, subject to pre-emption, if backup of the 18 primary transponders is needed.

But that's only half the story. Galaxy II is located too far east to provide full coverage of Alaska and Hawaii, thus lessening its value for Cable TV. It is situated for business communications to the contiguous 48 states. Hughes may make Galaxy II to data and business services what its twin (Galaxy I) has become to video.

A Galaxy III launch will be authorized by the FCC on the basis of a showing of need. An application for this launch is now pending before the Commission. The proposed 2° orbit spacing may eventually contain an assignment that may give a clue to its particular mission.

The minimum e.i.r.p. over the continental U.S. (CONUS) is 34 dBW.

Each tube is rated at nine watts. The satellite's lifetime is ten years, with a mission life of nine years. The satellites utilize dual polarization frequency reuse, with one sense aligned perpendicular to the Equator.

The first two satellites will be launched on the Thor Delta 3920/PAMs in 1983. There is a launch reservation for the second quarter of 1984 for a third satellite.

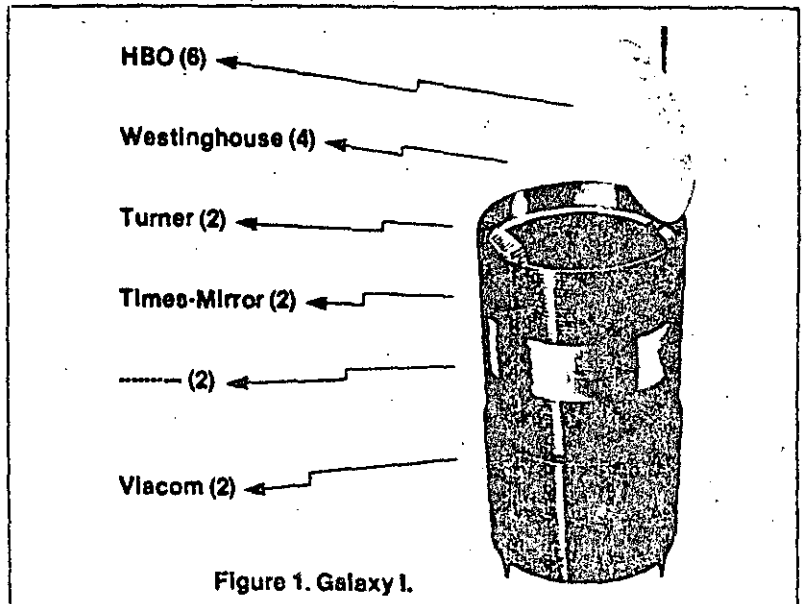
These satellites are part of the Hughes HS-376 family, which includes the SBS, Westar IV-VI; Anik C and D, Telstar 3 and Palapa B series.

The late-1979 filing with the FCC indicated estimated satellite costs (for three) of \$111.7 million, and \$60 million for two launches. By the time other earth and space segment costs (e.g. insurance and TT&C) were included, the total program cost was estimated at \$190 million. Inflation has probably boosted these costs as well.

The filing indicated that Hughes Communications, Inc. is 100 percent owned by Hughes Aircraft Co., which in turn is owned by the nonprofit Hughes Medical Institute, of Coconut Grove, Fla. The filing is unusual, in that it includes copies of documents signed by the late Howard Hughes.

Parameter	Galaxy
Owner	Hughes Communications, Inc.
Launches	1983, 83 & 84
Satellite Class	Hughes HS-376
TT&C Station	Brooklyn, N.Y. and Fillmore, Calif.
Control Center	El Segundo, Calif.
Orbit Locations	135 & 74 West
Transponders	24 (+ 6 spare tubes)
TWTA Power (W)	9
BOL Mass (kg)	476
EOL Power (W)	670

Summary Table



CS (Sakura) and CS-2a & -2b

By Walter L. Morgan,
Consulting Editor
Communications Center of Clarksburg

CS means Medium Capacity Communications Satellite for Experimental Purposes. Sakura (a Japanese word meaning cherry blossoms, following the custom of naming successful satellites after flowers) is the name for the first satellite in this series. CS-2a & -2b may use other names.

Sakura was launched in December, 1977 on a Delta 2914 and placed in geosynchronous orbit at 135° east longitude. CS-2a & CS-2b are operational satellites, scheduled for launch in February and August, 1983 from the Tanegashima Space Center in Japan, aboard the N-2 launcher.

These satellites carry two 6/4 GHz (C-band), and six 30/20 GHz (Ka-band) transponders on each. Sakura has been a useful training tool for learning how 30/20 GHz satellites can be operated under the non-optimum weather conditions encountered in Japan. This satellite has provided hands-on experience. CS-2a & 2b will carry this experience into operational use.

The 30/20 GHz antenna beam covers the main Japanese islands of Hokkaido, Honshu, Shikoku and Kyushu. The 6/4 GHz coverage is broadened to include the Ryukyu and Bonin Island groups. The antenna reflector has been contoured to shape the beams and to reduce the sidelobes on neighboring nations. A single circular polarization sense is used. The nominal e.i.r.p. is 29 and 37 dBW at 4 and 20 GHz respectively.

A despun antenna design is used. At Ka-band there is a 2 to 4 dB spin modulation on Sakura. The spin rate is 90 rpm.

Sakura relays TV and communications signals among the Japanese islands. These satellites have been constructed by Ford Aerospace and Mitsubishi (MELCO) for Japan's National Space Development Agency (NASDA). The operational experiments are being conducted by the Ministry of Posts & Telecommunications' (MOPT) Radio Research Laboratory, and the Nippon Telephone & Telegraph's (NTT) Yokosuka Electrical Communications Laboratory.

The spaceframe's origin is the NATO-III satellite series, also made by Ford.

Sakura has eight 200 MHz wide transponders at each frequency band for a total capacity of 1600 MHz supplied by Ford and NEC. Two of the

six Ka-band transponders developed problems (spurious signals and power supply tripout). The remaining four continue to be used for tests.

The CS-2 series of satellites each use two 180 MHz wide, 4 GHz channels, and six 130 MHz, 20 GHz transponders, for a total capacity of 1140 MHz. All of the CS-2 transponders are made in Japan.

Even before the launch of the CS-2 series, Japan's laboratories began working in a concerted manner on future generations of domestic communications satellites, which will use 30/20 and 50/40 GHz. These satellites are sometimes referred to as the Advanced CS, and as having "integrated transponders." This means that multibeam antennas with onboard regeneration and satellite switching will be used to obtain a high capacity satellite. Sakura and the CS-2a & 2b have a single antenna beam at each frequency band. The Advanced CS satellites may have four 0.5 degree (500 km diameter) beams, spanning the main Japanese islands.

The 30/20 GHz paths must pass through rain rate region D (similar to the rainfall in the U.S., east of the Mississippi and north of the Gulf states). At Kashima, the rain rate exceeds 40 mm/h (12 dB attenuation at 19.45 GHz) 0.01 percent of the time. During very heavy rainstorms, the experiments have included reducing the bit rate through the satellite and changing the error correction coding to a more robust structure.

Among the experiments that have been conducted are FM-TV, FM-phone, PCM-phone, PCM-TV, SCPC and SSMA (spread spectrum multiple access). Two TDMA burst synchronization methods were tried (noncoherent and clock coherent). TDMA rates used were 64.136 and 106.88 mbps.

After three years of testing, MOPT and NTT reported that a CS-like satellite would be suitable for future Japanese domestic service. The CS-2 series and Advanced CS demonstrate the strength of this decision. Sakura's nominal lifetime is three years. CS-2a & 2b's nominal lifetimes will be five years.

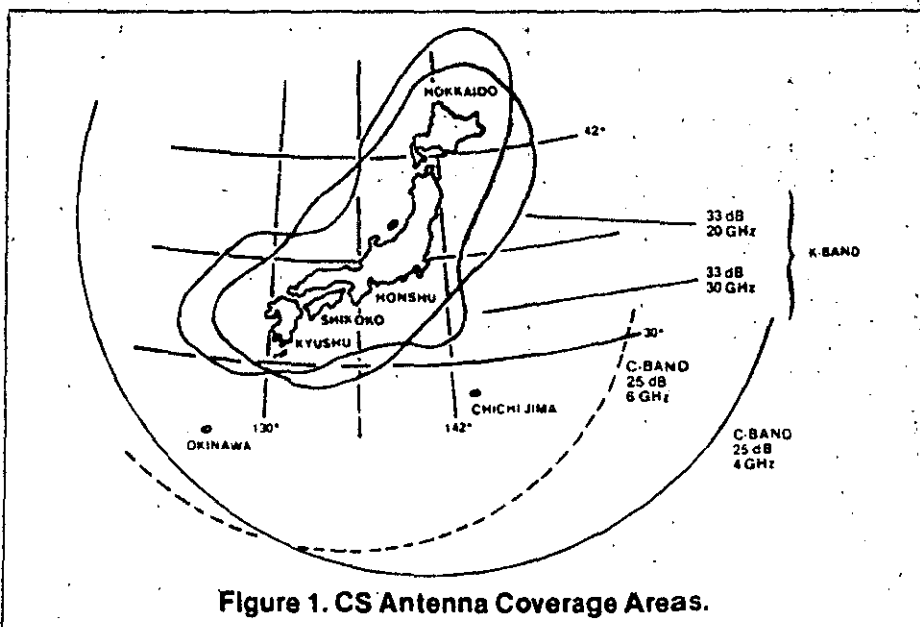


Figure 1. CS Antenna Coverage Areas.

Summary Table

Parameter	CS	CS-2
Owner	NASDA	NASDA & NTT
Launches	1977	1983 (2)
Control Center	Tsukuba	Kimitsu & Tateyama
Orbit Locations	135 E	130 & 135 E
Transponders	2 at 6/4 GHz + 6 at 30/20 GHz (each)	
TWTA Power (W) at 4 & 20 GHz	4 & 5	5 & 6
Bol Mass (kg)	350	350

By Walter L. Morgan, Consulting Editor
Communications Center of Clarksburg

Meteorological (weather and environment) satellites have been a major participant in the space program of many nations. Few, if any, satellite types have produced such massive and obvious benefits to the world's population.

Starting immediately after the 1960 launch of Tiros-I, weather forecasters finally had a reliable way of tracking storms as they ravaged their way across the ocean voids and into populated areas. With the addition of infra-red sensors, observations were possible at night. Daily observations of the global weather with complete profiles of clouds are routinely assembled along with data on ocean currents, temperatures, atmospheric temperature and humidity profiles, and solar particles.

The current Tiros-N/NOAA (National Oceanographic and Atmospheric Administration) satellites are derived from the Defense Meteorological Satellite Program (DMSP), operated by the U.S. Department of Defense. Both satellite series are made by RCA and operate at low altitudes in near polar orbits. Geosynchronous meteorological satellites like GOES provide an overview of the hemisphere and complementary coverage.

The Tiros/NOAA multi-mission sensing satellites provide information to oceanographers, hydrologists, and meteorologists about ocean currents, temperatures, sea ice and atmospheric/stratospheric conditions. In addition, the NOAA series collects data from remote fixed or moving sensing platforms (out of range of the geosynchronous satellites or needing a location determination). The Advanced Tiros-N/NOAA-E to -G satellites will provide search and rescue (SAR) functions for downed aircraft or ships in trouble, ozone mapping of the atmosphere, and measurements of the incoming and outgoing planetary radiation, in addition to their other functions.

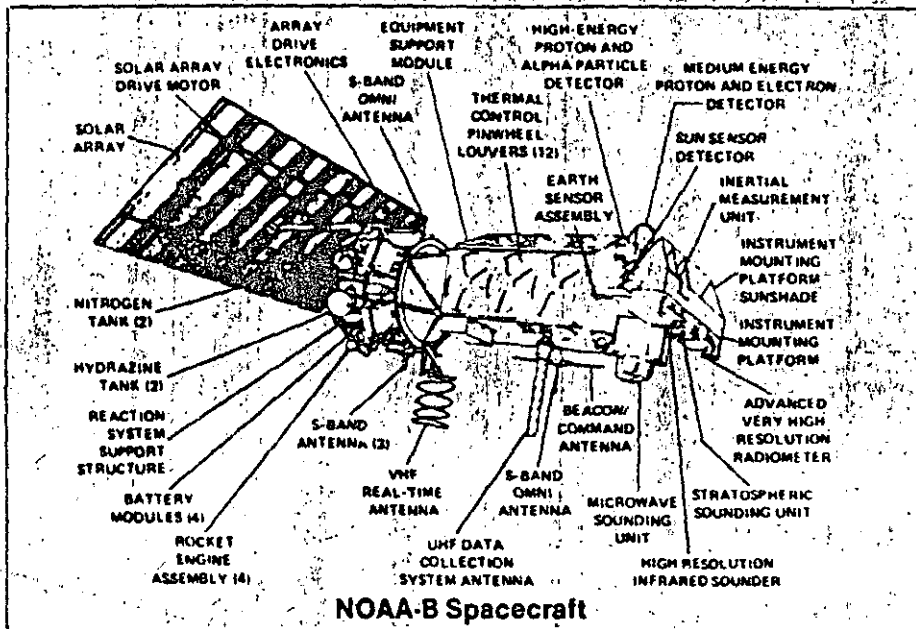
Extensive use is made of the on-board CPU (the Control Processing Unit) which provides the following

functions; a) guidance of the integral second stage using stored trajectory equations; b) velocity trim burns (to attain the desired orbit); c) spacecraft initial orientation; d) solar array erection and orientation; e) orbit position location (using ephemeris data updated weekly); f) sensor operation at the proper times to acquire data; g) data processing and compaction prior to recoding and transmission; h) data formatting; i) autonomous attitude control; and other functions.

Five 450-Mbit tape recorders are carried for recording the data when out of range of the earth stations.

The automatic picture transmission (APT) system permits over 120 nations and more than 1,000 low cost ground stations to "see" the images from the NOAA satellites as they pass overhead. These transmissions are sent at 137.50 and 137.62 MHz. Other data streams are transmitted at 1698, 1702.5 and 1707 MHz.

These satellites are maintained in near polar, sun-synchronous orbits. The orbit altitude and inclination are selected so the orbit plane tracks the sun by making one complete rotation per year. The launch vehicles have been retired Atlas-E and -F boosters.



Summary Table

Parameter	NOAA 6&7	DMSP
Family Name	Tiros-N	Block 50-1
Owner	NOAA	Dept. of Def.
Control Center	Suitland, MD	Offutt, NB
Orbit Altitude (km)	833 or 870	830
Orbit Inclination (Deg)	98.7 or 98.9	98.8
Orbit Period (Minutes)	101.6 or 102.4	101
Sensors	4	7
BOL Mass (kg)	771	513
BOL Power (Watts)	1250	1000
Solar Array Size (m)	2.4 x 4.8	1.8 x 4.8
Body Height & Width (m)	3.7 x 1.9	5.2 x 1.8

Leasat

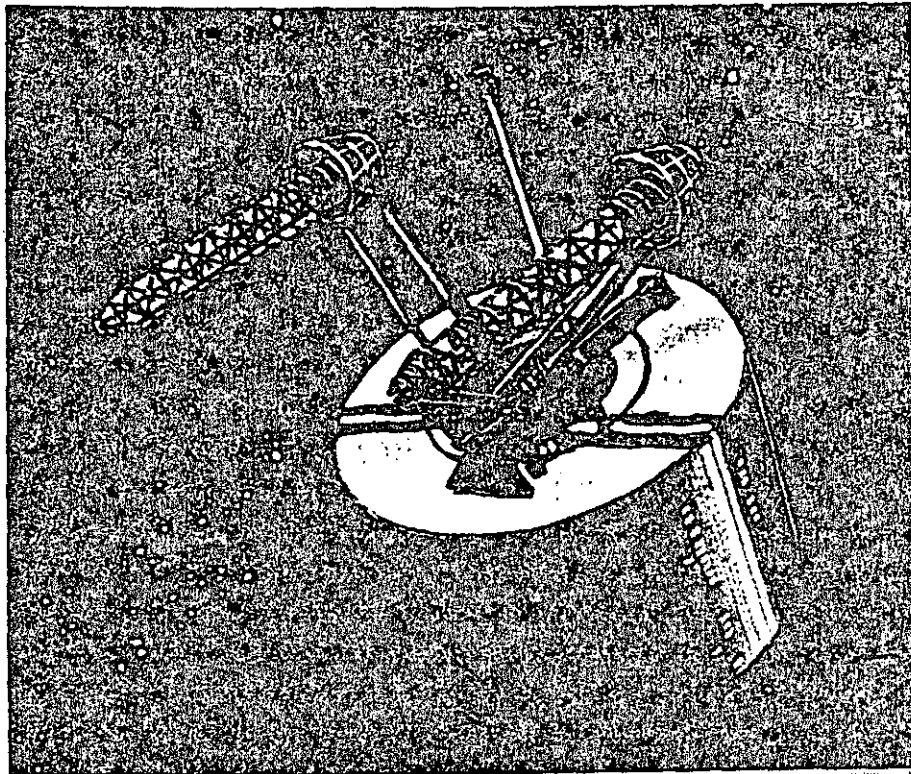
By Walter L. Morgan, Consulting Editor
Communications Center of Clarksburg

The Leasat satellite series is intended as the future replacement for the FleetSatCom system (see Satellite Notebook #5). These satellites represent a different approach to the provision of service to the U.S. military. In the DSCS program, satellites are fully owned and operated by the government, but in the case of Marisat, the government contracted for services of parts of three satellites for a limited period.

The original contract called for monthly payment for services for five years, at each orbit location. Unexpected delays in the STS (Shuttle) program have delayed the first scheduled launch, from 1982 to early 1984. This delay left Hughes with substantially increased construction costs, due to much higher interest rates and a longer construction time. The Navy will pay HCSI \$67 million in fiscal 1982, and varying amounts over the following six years. Total contract value is \$335 million, including earth stations and control facilities.

The Leasat satellites are an outgrowth of the Syncom-IV program, and are intended solely for launch on the Shuttle. Most spacecraft ride upright in the Shuttle's cargo bay, but the Leasat will ride on its side, so its diameter can be the maximum allowed (4.22 meters) while occupying less than half of the shuttle bay length. Virtually no room is needed for the ascent stages, as they are self-contained. Total length is 4.3 meters. Like most Hughes satellites, Leasat is drum-shaped and spin-stabilized. It is ejected like a frisbee from the STS. Two large helical antennas provide global coverage.

Leasat has its own internal propulsion system, thus eliminating the need for external perigee and apogee kick motors. The perigee stage (a solid motor from the Minuteman III) is jettisoned after use. The two 440-Newton liquid apogee motors (LAM) use a bipropellant. The RCS system is monopropellant, and uses six 22-N thrusters. The LAM and RCS can be used independently or in combination during ascent and on-orbit, for various maneuvers.



The satellite's drum has a surface area of about 40 square meters, and generates 1100 Watts after seven years. The repeaters require 700 Watts, and the nominal lifetime of the satellite

is ten years. Four satellites are planned, one each over the U.S., Atlantic, Pacific and Indian Oceans. A fifth satellite is a spare. Operating frequencies are similar to FleetSatCom's.

Summary Table

Operator:	Hughes Communications Services, Inc.		
User:	U.S. Department of Defense		
Launches:	Two in 1984, two in 1985		
Control Center:	El Segundo, Calif.		
Locations:	75° E, 176.5° E, 100° W and 23° W		
Mass (kg)		Stationkeeping:	
Out of Shuttle:	6898	-inclination:	3°
PKM/adaptor:	314	-longitude (+ or -):	1°
Expendables:	5350	Antenna pointing	
End of life:	1234	(+ or -)	0.5 degree
Communication:	204	Frequencies-uplink:	300 MHz
Power & distribution	309		8 GHz
		-downlink:	250 MHz
		Total kHz (each way)	675

Initial European DBS Satellites

By Walter L. Morgan, Consulting Editor
Communications Center of Clarksburg

A study of the European broadcasting satellites provides a first-handed hint of what may happen in other parts of the world, as well as raising a host of questions about DBS.

Technical questions, such as footprint spillover, antenna pointing accuracy and compatibility of varying national TV standards (SECAM and PAL are mutually incompatible), seem simple when compared to the policy questions involved.

Some policy points which will need to be addressed include: who will be authorized to program the satellite channels; commercial sponsorship and limits; the number of languages carried; programming standards; pay or free TV; scrambled or non-scrambled; cultural "exportation"; impact on cable TV and over-the-air broadcasting; and the role of the European Broadcasting Union (EBU). Use of the five TV channels raises more questions: leased transponders; private or government ownership; should channels be leased to non-nationals; radio and TV mix on satellite; should channels be available for lease for as little as an hour; and so forth. As well, more questions on protection for current TV networks have arisen: should "foreign-origin" broadcast satellite signals be allowed to enter cable TV systems; will network viewers be lost to DBS, and if so, how many; and the question of trans-border video.

Institutional aspects of DBS in Europe include deliberate transborder programming (perhaps in a language foreign to the channel's nation of origin, with advertising directed towards neighboring nations), propaganda, legal aspects and finally, the question of whether nations should undertake the joint ownership and operation of a multinational satellite at 19°W. The next growth locations will be 31° and 37°W.

Eventually, the grouping of European DBS birds at 19° W will be replaced by a large platform (LASP). Bandwidth, power, patterns, orbit locations and frequencies have been specified at the WARC-77, so the concern for

changing requirements which has in the past inhibited the development of LASPs does not exist. Nations at 19° W include France (TDF-1), Germany (TV Sat-A3), Switzerland, Luxembourg, Italy, Austria, Belgium and the Netherlands. Five African nations and ESA's L-Sat 1 (to provide experimental broadcasting to Italy) round out the usage of that orbital slot.

Currently, European DBS spacecraft are under design and fabrication for France and West Germany, for launches in 1985 on the Ariane 3. Both series are being built by the Eurosatellite Group (France's Aerospatiale and Thomson CSF; Germany's MBB and AEG-Telefunken). The French satellite will be integrated at Cannes, and the German one at Otobrunn. The group is a 50/50 German/French venture, with an industrial return plan of 54/46 percent. Two protoflight models (one for each nation) and a spare (with a full set of mission-unique spares) are being built. The differences between the satellites are in coverage, power and number of active channels.

A common bus design serves the TDF/TV-Sat satellite group. It uses redundant double-gimballed momentum wheels, a structure approximately 2.4 meters square and six meters

high (including antennas), heat pipes and two propulsion systems (chemical and ion). A unified propulsion stage is used for ascent. Neither satellite will broadcast during the eclipse, 0112 to 0224 Central European Time (worst case).

Home earth stations for the service will use antennas in the range of 60 cm (two feet) to several meters in diameter. The uplinks are between 18.3 and 18.7 GHz, while the downlinks are in the 11.7 to 12.5 GHz band. Polarizations are linear, and direct radio will be provided by some nations, in addition to video. Residents of many nations will be able to select among several different programs. Choice of antenna size may be as shown in the table.

The 1977 WARC on Broadcasting Satellites allocated orbit locations and channels on an "a priori" basis, and most nations in Europe got five channels each, without regard to size or population. If the same planning were used, an analogous situation for the 1983 Region 2 RARC might be the assignment of the same number of channels to the islands of St. Pierre and Miquelon (French territory east-northeast of Maine) as to the entire U.S. or Canada.

Viewing City	Viewing Options				
	OTS	TDF	TV-SAT	UKSAT	LUXSAT
Amsterdam	C	A	A	B	C
Bern	C	A	A	C	C
Bonn	C	A	A	C	A
London	C	A	C	A	D
Madrid	D	C		D	
Paris	C	A	B	B	B
Rome	D	B	C		
Warsaw	D	C	C		

CODE: A = 0.6m, B = 0.9-1m, C = 2m, D = 4m

Satellite Notebook # 14

Spacenet

By Walter L. Morgan
Consulting Editor
Communications Center of Clarksburg

The Southern Pacific Railway constructed a major corporate telecommunications facility in the 1960s along its extensive right-of-way through the middle and western U.S. By the late 1970s, this network had grown into a public long-distance telephone network, now known by its service name of "Sprint," which is operated by the SP Communications Corp. (SPCC).

SPCC has been authorized to provide satellite services via a new family of satellites to be known as "Spacenet." SPCC has been using other people's satellites for many years to provide its private and dial-up telephone and data services. Thus, this move was not a surprise.

The Spacenet satellite is innovative, in that it will carry the equivalent spectrum of 36 conventional (36 MHz) transponders on a launch vehicle (originally the Delta and now the Ariane) that normally carries only 24.

As well as full frequency reuse at 6/4 GHz, additional transponders are carried for single polarization use of 14/12 GHz. Individual transponder bandwidths are 36 and 72 MHz (12 of each, see table). Both Hughes TWTAs and RCA solid-state power amplifiers (SSPAs) are used.

The FCC has authorized SPCC two locations, and there is a request for a third satellite location pending. SPCC has signed a more than \$100 million contract with RCA Astro-Electronics of Princeton, NJ for three spacecraft, the first year's operation, etc. Options include a fourth and parts for a fifth Spacenet bird.

Spacenet I will carry mainly video users (see below). At 6/4 GHz, it can cover all 50 states and the Caribbean. At 14/12 GHz, its coverage is limited to the original 48 states (see figure). Due to its location, Spacenet II can only cover 48 states, and thus has a more business-oriented customer base. SPCC plans to establish a series of "thin route" earth stations to expand the Sprint system coverage to cities now too far off its present microwave network.

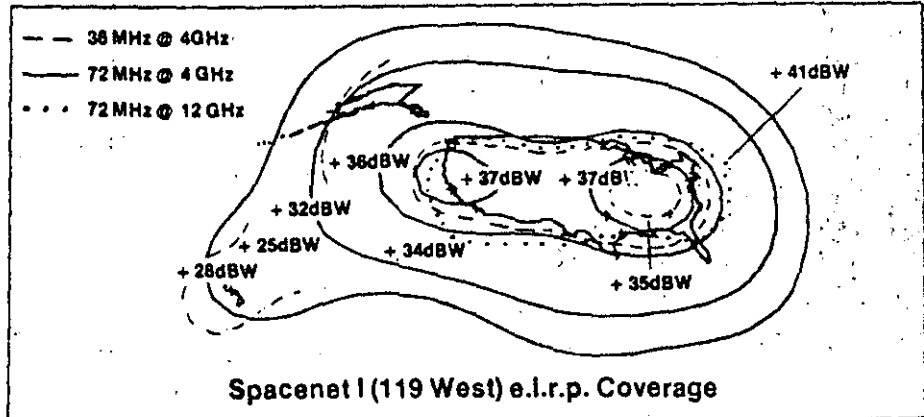
Financing a satellite system is no

small task. According to press reports, SPCC has been looking for a team of partners (GE & American Express, and Federal Express & Cox Broadcasting have been frequently mentioned). The best "partner" so far has been the Arianespace group in Europe. Well below prime rate loans (payable after the system revenue starts), and a launch vehicle price about 25 percent below what the Europeans themselves pay, made Spacenet one of the first North American Ariane users.

Transponders have been leased on the first and second satellites. Customers on Spacenet I include SSS, SIN, NBC, United Video, Bonneville and the Baptists. Spacenet II users include Bonneville, Guadalupe Associates, Lincoln Network and the Pop Network.

The current annual protected transponder lease rates are \$2.1 million for 36 MHz, \$3.84 million and \$4.2 million for the 72 MHz transponders at 4 GHz and 12 GHz respectively. Many of the 72 MHz channels will be operated on a two-TV per transponder basis. This technology is still being developed, especially for small CATV earth stations. A Spacenet I users group has proposed to erect 1000 earth stations for CATV operators under the name of "Earthnet I." The Baptists have announced plans to construct 10,000 TVROs at their U.S. churches.

The spacecraft design demanded weight savings. These are embodied in the form of nickel-hydrogen batteries and electrically heated thrusters (EHT). Full eclipse operation is planned. □



Summary Table

Parameter	Value
Owner:	SP Communications Corp.
Launches:	February & August, 1984
Control Center:	McLean, VA
TT&C Station:	Cooksville, MD
Orbit Locations Assigned:	119 & 70° West
Transponders:	
6/4 GHz	12 at 36 MHz at 8.5 Watts 6 at 72 MHz at 16 Watts 6 at 72 MHz at 16 Watts
14/12 GHz	1296 MHz
total bandwidth:	670 kg
Mass at BOL:	7.5 years
Minimum lifetime (fuel):	

DSCS-III

By *Walter L. Morgan,*
Consulting Editor,
Communications Center of Clarksburg

The Defense Satellite Communications System, Phase III (DSCS-III) represents a new generation of military communications satellites. These satellites can communicate to fixed and transportable earth stations, in addition to aircraft and ships. This is a more flexible design than any prior military communications satellite. The DSCS-III can reallocate its transmitter power, receiver sensitivity and coverage. In doing so, it can be protected against jammers or produce an optimized division of its resources.

It has been designed to be survivable by using a hardened command system at S-band (2 GHz) and SHF (8 GHz) and an antenna system using multiple beam antennas as well as conventional horns and a gimballed dish. It also can control the transponder gain over a 39 dB range. The satellite can be operated in FDMA, SSMA (spread spectrum), and single carrier modes.

Various antennas provide global (1), one degree spot and a gimballed three degree (2) coverage. Each of the two transmit multibeam antennas (MBA) (3) have 19 "sub-beams" that are turned on/off to produce various beam shapes for selective coverage. For reception, the MBA (4) has 61 such "sub-beams" for nulling and interference rejection. Because of this flexibility, no antenna pattern is included in this notebook page. All beams use circular polarization.

The body (5) is a cube about two meters on the side. When the solar array (6) is deployed, it has a tip-to-tip span of 11.6 meters (almost as tall as a four-story building).

The Titan and the Transtage or the Inertial Upper Stage (IUS) permits direct injection into GEO (no apogee motor required). In some cases the stage is left in the geostationary orbit. As has long been the DSCS tradition, multiple satellites are injected at the

same time. The first DSCS-III research and development satellite will be paired with a DSCS-II for launch this fall.

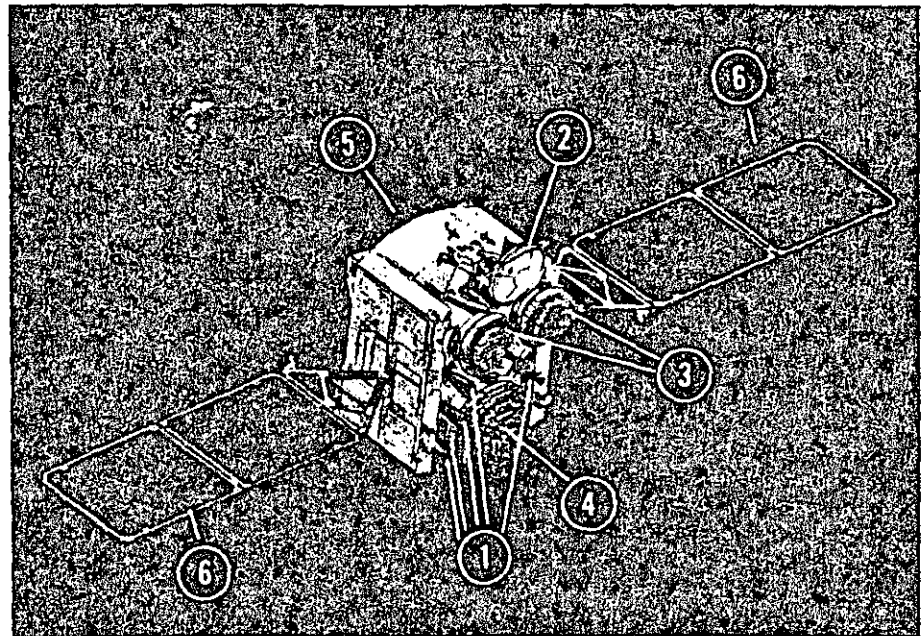
The DSCS family started with DSCS-I (IDSCP) made by Ford. The DSCS-II comes from TRW. General Electric (GE) is the manufacturer of the third phase of the space segment.

Two R&D flight models plus a refurbishable model are being built. Plans call for the production of 12

flight models (including the refurbishment of the R&D qualification model).

Three-axis stabilization is used to achieve a 1.2 degree antenna pointing accuracy.

The six SHF transponders can be interconnected to various input and output antenna combinations. Extensive onboard path switching is used to further extend the communications reliability and versatility.



Summary Table

Parameter	Value
Owner	Defense Communications Agency
Launches	1982 - ?
Launcher	Titan or Shuttle & IUS
Control Center	Sunnyvale, CA
Potential Orbit Slots	60° & 175° East 12° & 135° West
Transponders — 8/7 GHz	1 (50 MHz at 10 Watts) 2 (60 MHz at 10 Watts) 2 (60 MHz at 40 Watts) 1 (85 MHz at 10 Watts) (Plus 2 spares each at 10 & 40 Watts)
Total Bandwidth	375 MHz
— UHF	1
E.i.r.p.	23 to 44 dBW
Mass at BOL	816 kg
Power at EOL	837 Watts
Minimum Lifetime (fuel)	7 years 10 years

ANIK-C

By **Walter L. Morgan**
Consulting Editor
Communications Center of Clarksburg

Anik-C is a three-satellite series being built by Hughes Aircraft Co. (prime contractor) and Spar Aerospace Ltd. of Canada (a subcontractor) for Telesat Canada. In the Anik-D series the Hughes/Spar roles are reversed.

The Anik-C series operates at 14/12 GHz (uplink/downlink frequency bands) with appreciable radiated power (47 dBW) using multicollector TWTAs and a spot beam antenna system. These beams may be operated as four independent spots ("quarter-Canada") or paired for "half-Canada" coverage.

The first satellite to be launched (which will probably be Anik-C3) has had up to 14 of its 16 transponders leased to two United States organizations (GTE and Oak Satellite) for various purposes (primarily DBS demonstration and MATV services). Telesat will tip the beams southward 0.5 degrees and westward 0.3 degrees to better cover the United States. This will be done by fooling the beacon tracking antenna pointing system. A new beacon transmit station will be constructed by Telesat Canada within the United States. By turning off the Allen Park, Ont., station and turning on the U.S. transmitter, the antennas will be tipped southwest.

These satellites were leased at 10 percent over the rate charged other Canadian users. The U.S. rates are Canadian dollars 2.5 million (or approximately \$2 million in U.S.) per year per 54 MHz transponder. Similar leases are available on the Anik-D series. In theory these leases are provided because there are no idle equivalent U.S. transponders available at the instant. The traffic will transition to U.S. transponders as soon as the GTE or Oak satellites become available in either the 14/12 GHz or the DBS frequency band. The contracts need approval of the Canadian and U.S. governments, the Canadian Radio-Television & Telecommunications Commission and the FCC.

The far north of Canada must rely on the aging Anik-B1 and a future Anik-C (probably C2) for service.

If Canada needs the capacity, it

can preempt the leases. There are two classes of preemption: immediate (for restoring existing Canadian service) and with a 12-month notice (for a scheduled future Canadian need).

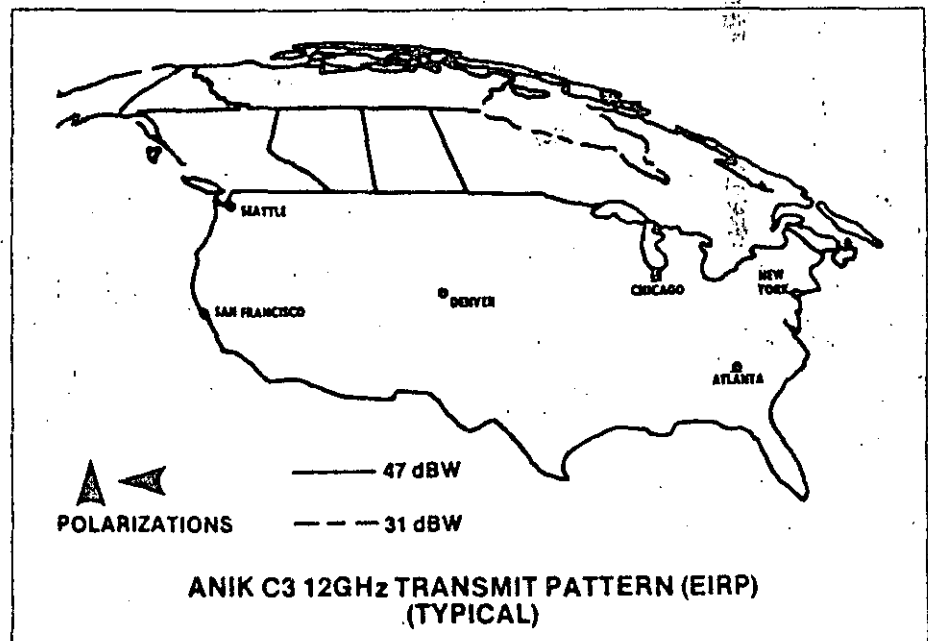
The satellites use the Hughes HS-376 spin stabilized designs and outwardly resemble the SBS, Palapa-B, Westar and Galaxy satellites described previously in this series.

Anik-C3 and SBS-C will be the first commercial users of the Shuttle. Each spacecraft is carried in a cradle in the cargo bay and is ejected vertically with its PAM-D (SSUS-D) solid motor.

The PAM converts the low (Shuttle) orbit into the elliptical transfer orbit. A subsequent firing of the apogee kick motor injects the satellite into the geostationary orbit.

The Anik-C satellites were intended to provide heavy and medium route message services and high-quality TV distribution within Canada. Each transponder can accommodate two FM-TV carriers or 91 Mb/s.

There are four spare TWTAs. In the event of a failure of a TWTAs, the traffic can be diverted to a neighboring TWTAs or a spare.



Summary Table

Parameter	Value
Tentative Launch Sequence	C3, C2, C1
Owner	Telesat Canada
Launches	November 1982, April 1983, & April 1984
Control Center	Ottawa
Orbit Locations Assigned	112.5, 116 & 109 West
Transponders at 14/12 GHz	16 at 54 MHz at 15 W
Total Bandwidth	864 MHz
Mass at Beginning of Life	567 kg
Maximum Lifespan (design)	8-9 years
	10 years

Japan's Broadcasting Satellites BSE (Yuri), BS-2a & BS-2b

By Waiter L. Morgan,
Consulting Editor
Communications Center of Clarksburg

Toshiba and General Electric teamed to produce a series of direct broadcasting satellites for Japan. The first was launched on the Delta on Apr. 7, 1978. Subsequent launches will use Japan's N-2 launcher from the Tanegashima Space Center. The first Broadcasting Satellite, an experimental satellite, was placed at 110 East and was named Yuri (meaning Ily). From this location, the satellite pattern covers Japan and the outlying islands as shown in Figure 1.

Japan is in ITU region 3 and therefore uses the band 11.7-12.2 GHz for the Broadcasting Satellite Service. At the WARC-77, Japan was assigned channels 1, 3, 5, 7, 9, 11, 13 and 15 from the 110 east position.

The typical earth station size used in the BSE tests varied from 1-1.6 meters on the main Japanese islands and up to 4.5 meters on some of the remote islands. The goal was a video signal-to-noise ratio of at least 45 dB (TASO grade 1).

The two transponders on "Yuri" had 50 and 80 MHz bandwidths, facilitating experiments in high definition satellite TV. The luminance channel used the 80 MHz transponder, while chrominance information occupied 25 MHz of the other transponder. Other tests included digital (Pulse Code Modulation) TV and TV with up to five companion audio channels.

The satellite was body stabilized

with a ± 0.2 degree accuracy in pitch and roll. The yaw accuracy was ± 2 degrees. As is typical of broadcasting satellites, the high TWTA power required advanced thermal control techniques. Fourteen heat pipes were placed on the north-facing panel to dissipate the heat from the tubes.

The planned lifetime of "Yuri" was three years due to fuel limitations, but all three of the 100 watt TWTA's failed in 27 months terminating the mission early. The failure believed to have been caused by a high voltage breakdown in the TWTA power supplies.

The BS-2a and -2b are essentially identical to the first BSE, "Yuri." However, steps have been taken to improve the TWTA reliability and the antenna pointing accuracy to 0.1 degrees.

The BS-3 is in the early definition stage, with launches anticipated in the late 1980s. It is expected that this satellite will display the WARC-77 mandated technical characteristics as shown in the summary table. If the full 64 dBW is radiated using a 3.52 x 3.3 degree beam, the individual TWTA's will have an output power rating in excess of 1,000 watts. If eight active tubes are carried, the power supply demands will exceed 15 kilowatts. Recent technical improvements in earth stations place lighter demands on the satellite than envisioned in 1977, thus these values may represent only the upper limits.

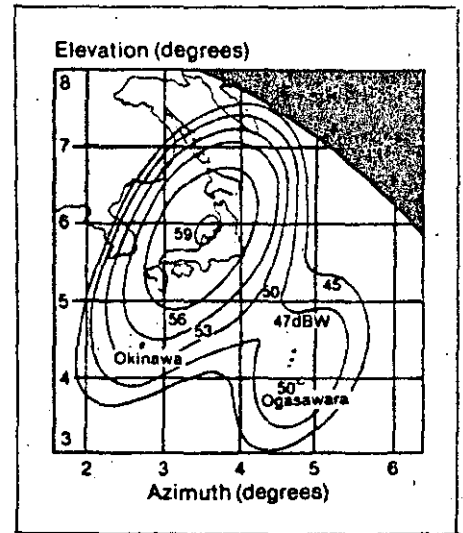


Figure 1

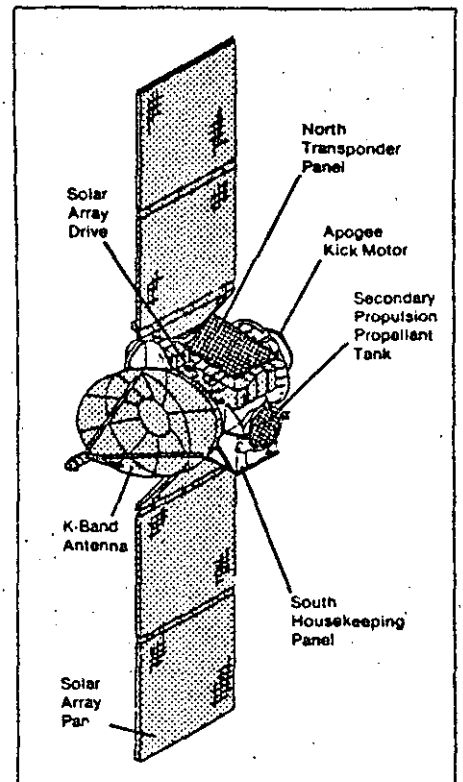


Figure 2

Summary Table

Parameter	Value		
	BSE	BS-2	WARC-77
Developer		National Space Development Agency	
Launches	1978	84 & 85	887
Launcher	Delta	N-2	H or STS
Orbit Locations	110	110	110 East
TV Transmitters	2	2	8
elrp	55.3	55.3	63.2-64.4 dBW
Mass at Beginning of Life	354	350	- kg
Power at End of Life	780	800	15,000 watts
Minimum Lifetime	3	3	- years

GSTAR

By *Walter L. Morgan,*
Consulting Editor
Communications Center of Clarksburg

The GTE Satellite Corporation (GSAT) of Stamford, Conn., has contracted for three high-capacity 14/12 GHz domestic satellites for digital voice, data and video distribution. RCA Astro Electronics is constructing these satellites for a cost of approximately \$100 million.

The GSAT satellite system will consist of two operating satellites and a spare. In July 1982, GSAT applied to the Federal Communications Commission for authority to launch the third satellite and to construct an additional spacecraft to be held in reserve.

The GSAT satellites, called GSTARS, are designed for high power output. The solar array power is 1900 Watts, representing about two and a half times the original Satcom capacity. The satellite mass has increased to 1250 kg in transfer orbit.

The GSTARS utilize switchable east and west spot beams as well as a CONUS beam. Fourteen active and five spare 20-watt TWAs access the 48 contiguous states. In addition, two active and one spare 30-watt TWAs may be selected for 50 state coverage. There are three different patterns in each of the two polarizations (see Figures).

The satellites operate in the 14.0-14.5 GHz (uplink) and 11.7-12.2 GHz (downlink) bands. Unlike other satellites in this frequency band, the GSTAR polarization axes are tilted 26 degrees to reduce rainfall depolarization effects in the Southeastern United States.

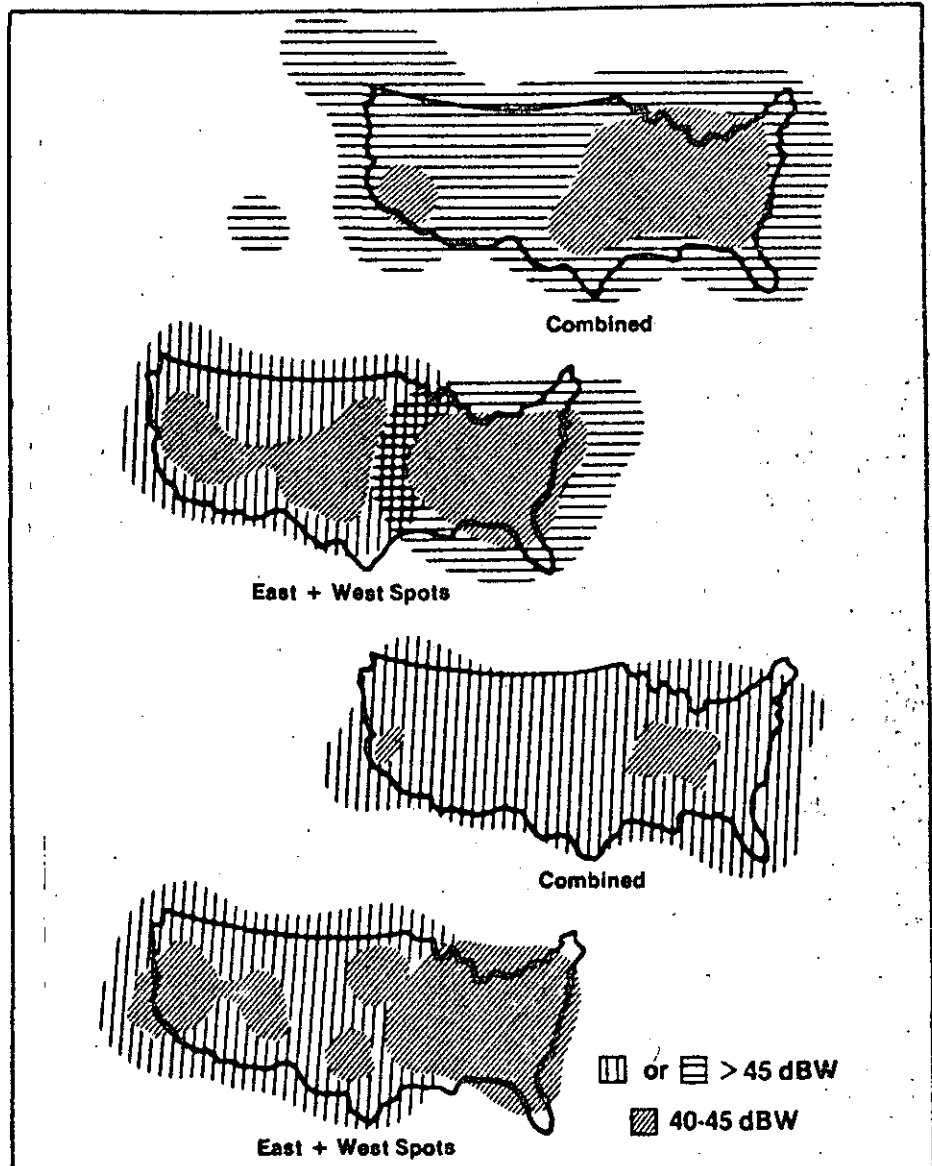
The earth station transmit and receive antenna beams are narrower than if used at 6/4 GHz, therefore the satellite stationkeeping requirements are ± 0.05 degrees. The satellite's spot beams require better attitude control (pitch: ± 0.04 ; roll: ± 0.05 and yaw: ± 0.13 degrees). The three axis stabilization system uses a momentum wheel operating at 6500 rpm.

The satellites use switchable limiters in front of the TWAs to reduce up to 10 dB of the effect of variations in the uplink (such as caused by rain attenuation). Switchable 0 to 21 dB attenuators establish the clear sky uplink operating point (limiter on) or

the saturation flux density level (limiter off).

The digital services will be operated at 60 and 90 Mb/s. A typical 60 Mb/s earth station will be equipped with one 5.5 to 7.7 m antenna, one 125 K LNA, one 500 W transmitter and an additional LNA transmitter for redundancy. Sim-

ilarly, the 90 Mb/s station will consist of a 7.7 to 8.9 m antenna, a 125 to 225 K LNA, a 1,000 W transmitter and a spare LNA transmitter. The 90 Mb/s QPSK service uses the spot beam transponder. The system provides 99.7 percent availability or 10^{-3} bit error rate for voice and 10^{-7} BER for data.



Summary Table

Owner	GTE Satellite Corporation
Launch dates	May and August 1984
Launch vehicles	Ariane 3 (or STS)
Assigned orbit locations	103 and 106 west
Transponders	16 at 54 MHz each
TWAs	20 and 30 Watts
Design life	10 years
Configuration	see October 1981, page 22
eirp	See Figures
Verified	July 22, 1982

By Walter L. Morgan
 Consulting Editor
 Communications Center of Clarksburg

As a help to our readers of the "Satellite Notebook" we are providing a glossary of some of the satellite-unique terms that have been used.

Term	Meaning (Units)	GHZ	Gigahertz (1000 MHz).
Apogee	The highest point in the satellite's orbit (km)	HDTV	Higher (than normal) definition TV.
Apogee	A rocket stage used to convert the elliptical	HS-333 & HS-376	Families of Hughes satellites.
kick motor (AKM)	transfer orbit into a circular geosynchronous orbit.	Hydrazine	A commonly used liquid propellant for stationkeeping.
Ariane	A European launch vehicle.	IM	Intermodulation distortion occurs when two (or more) signals are passed through a non-linear device (such as an amplifier).
Atlas	A U.S. rocket stage.	Inclination	The angle between the Earth's equatorial plane and the orbit plane of the satellite. (deg.)
Attitude control	Maintenance of the satellite's orientation with respect to the Earth and Sun.	Isotropic antenna	A theoretical antenna that radiates (or receives) the same amount of signal in all directions.
Bandwidth	The useful frequency range of a device such as a transponder. (MHz)	IUS	Inertial upper stage, a rocket motor system.
Beamwidth	The angular coverage of an antenna beam	kg	Kilograms (1 kg = 2.2 lbm).
	Earth station beams are usually specified at the half-power (or -3 dB) point. Satellite beams are based on the area to be covered.	lbf	Pounds force.
Body stabilized	A satellite attitude control system using the gyroscopic stiffness of one (or more) spinning wheels.	lbm	Pounds mass.
BOL	Beginning of life.	Location	The satellites assigned longitudinal position over the equator. (East or West longitude.)
BSS	Broadcasting satellite systems are intended for transmission to small home or community receivers.	Mb/s	Megabits per second.
Cargo bay	The part of the Shuttle used to carry satellites.	Motor	A rocket stage.
CATV	Cable television.	Nutation	An imbalance in a spinning object.
Channel	(1) A half-circuit. (2) A radio frequency assignment (which is dependent upon the frequency band and the geographic location).	Orbit altitude	Height above the earth's surface (km).
Circuit	(1) A complete (two-way) telecommunications loop. (2) Two half circuits.	Orbit period	The time for the satellite to make one full revolution in its orbit. (min.)
Colocated	Multiple satellites sharing (approximately) the same location.	Orbit spacing	The angular separation (measured in degrees of longitude) between satellites using the same frequency and covering overlapping area. (deg.)
CPU	Central processing unit.	Orthogonal	At opposite (or right) angles to another form of intelligence.
dB	A logarithmic representation of a ratio.	PAM	Perigee assist module, a rocket stage.
dbi	The ratio of the gain of an actual antenna to an isotropic radiator using decibels.	Perigee	The lowest point in a satellite's orbit. (km)
DBS	Direct broadcasting satellite service.	Platform	A structure in space containing multiple missions.
dBW	The ratio of the power to one Watt expressed in decibels.	RARC	Regional Administrative Radio Conference.
Delta	(1) The amount of change in a quantity. (2) A U.S. launch vehicle family.	SCPC	Single channel per carrier.
Downlink	The space-to-earth path.	SCPT	Single carrier per transponder.
e.i.r.p.	Equivalent isotropically radiated power is the amount of power that would need to be fed into an isotropic antenna to match the flux level from an actual antenna. (dBW)	Scramble	Deliberate distortions of information to permit only authorized reception.
EOL	End of life.	Solar array	A power generation method using solar cells.
FDMA	Frequency domain (or division) multiple access.	Spin stabilization	Attitude control by spinning most (or all) of the satellite's exterior.
FEC	Forward error control adds unique codes to the digital signal at the source so errors can be detected and corrected at the receiver.	SSMA	Spread spectrum multiple access.
FM-TV	Frequency modulated TV.	SSPA	Solid state power amplifier.
FSS	Fixed satellite service. The earth stations are non-mobile. This service generally provides telephony and TV distribution.	Station	The assigned satellite location (East or West longitude).
GEO	Geosynchronous or geostationary.	Stationkeeping	Maintaining the assigned location (deg.).
Geostationary	A geosynchronous satellite that has a zero inclination angle. This satellite appears to hover over one spot on the earth's equator.	TDMA	Time domain (or division) multiple access.
Geosynchronous	An orbit whose period exactly matches the Earth's rotation rate (about 24 hours).	Thruster	A small rocket motor.
		Transfer orbit	An intermediate orbit used to reach the geosynchronous orbit.
		Transponder	A combination of one or more receivers, filter, frequency converters and transmitters to form a signal repeater.
		TT&C	Tracking, telemetry and control.
		TWT	Traveling wave tube.
		TWTA	An amplifier using a TWT and power supply.
		Uplink	Earth-to-space path.
		WARC	World Administrative Radio Conference.

Arabsat

By Walter L. Morgan
 Consulting Editor
 Communications Center of Clarksburg

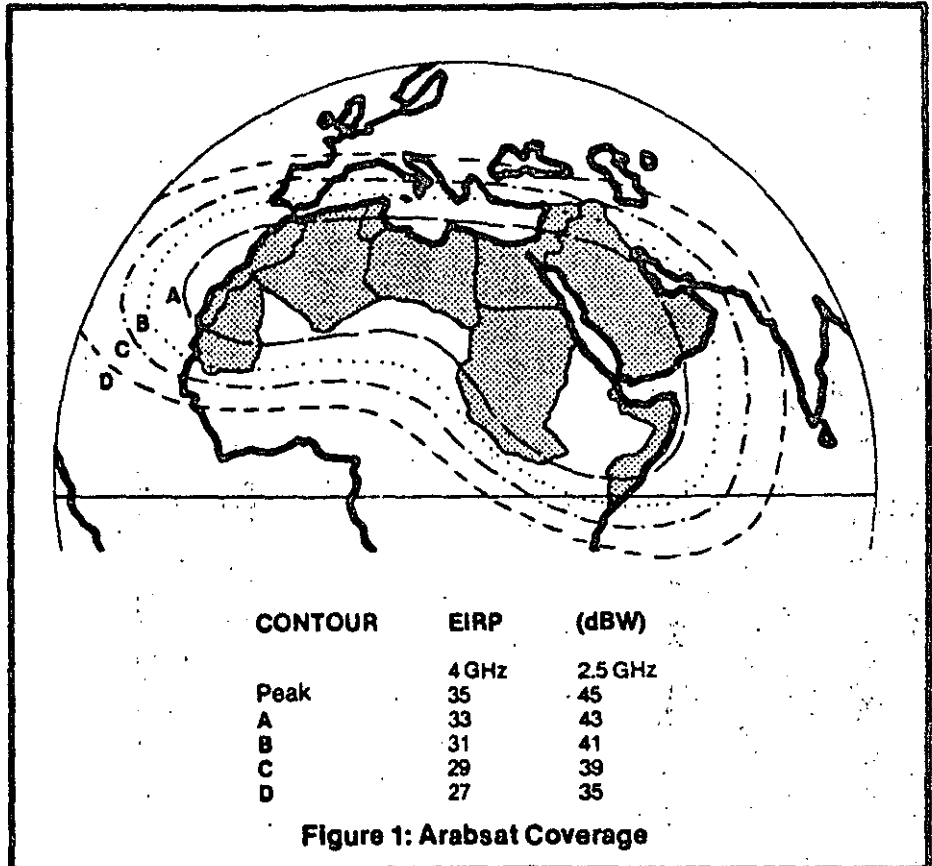
The Arab Satellite Communications Organization (Arabsat) is a consortium of Arab organizations spread through Africa and the Middle East. The organization is headquartered in Riyadh, Saudi Arabia. The Arabsat consortium is 26 percent funded by Saudi Arabia. It has entered into a \$134 million contract with Aerospatiale (France) and the Ford Aerospace and Communications Corp. as the principal subcontractor for three spacecraft to perform both fixed satellite services (FSS) and community television distribution service.

The present plans are for the first of these satellites to be launched on the European Ariane. The second will fly on the Shuttle. Technical advice is being provided by the Comsat General Corporation (USA). The contract for the TT&C stations and the control center is now being negotiated.

The portion of the world to be covered is shown in Figure 1. It is approximately 8000-km (east-west) and 4500-km (north-south). Many of the countries have already gained satellite communications experience as users of Intelsat services for international and domestic communications.

Arabsat is yet another indicator of the growth of regional telecommunications. In this case the common goal is the economic independence of the region. Each Arabsat satellite contains 25 transponders, each of 33 MHz bandwidth, operating at 6/4 GHz, and one transponder operating at 2.5 GHz. Eight thousand half-circuits are for regional and domestic applications. There are seven TV transponders and one for community TV use.

The community TV transponder has a 6 GHz uplink and a 2.5 GHz downlink and provides an edge of coverage e.i.r.p. of 41 dBW. The use of 2.5 GHz permits the fabrication of relatively simple earth stations. This frequency was first used in the Rocky Mountain States experiment on ATS-6 and was in use on INSAT. The earth station sizes are shown in Table 1.



Summary Table 1

Parameter	Value
Owner	Arab Satellite Communications Organization
Launches	February 1984 on Ariane August 1984 on Shuttle
Locations	19° & 26° East
Transponders	25 of 33 MHz each at 4 GHz 1 of 33 MHz at 2.5 GHz
Tubes	25 of 8.5 watts each at 4 GHz 3 of 50 watts each at 2.5 GHz with two operating in parallel and one spare
Lifetime	7 years
Earth Stations	
2.5 GHz TVRO	3 m (11 dBI/K)
6/4 GHz FDM/FM Voice	11-12 m (31.7 dBI/K)
6/4 GHz SCPC/C FM Voice	11-12 m (31.7 dBI/K)
6/4 GHz FM Video	11-12 m (31.7 dBI/K)
Verified	September 22, 1982

Telstar 3

By Walter L. Morgan
Consulting Editor

The Telstar satellites are the successors to the Comstar series (see Satellite Notebook 6, August, 1981). While Comstar brought Comsat General, AT&T and GTE together, they have all announced their own systems. Comsat has an investment in SBS, GTE in GSTAR & Spacenet and AT&T in Telstar 3.

Various temporary designations have been given to the Telstar 3 series. NASA once used ATT-1, etc. now uses Telstar 3A, 3C and 3D. AT&T Long Lines indicates that permanent designations (Telstar 301 to 303) will only be assigned after they have been successfully placed on station. (Telstars 1 & 2 were medium-orbit experiments launched many years ago). An application is outstanding for a fourth launch (304). A reservation for a May, 1984, Delta flight (Telstar-3B in NASA's terminology) is no longer needed.

The new satellites are part of the Hughes HB-376 family (see prior Notebook pages for SBS, Palapa-B, Anik-C, Westar IV and Galaxy). All family members have the same exterior, but inside the branches reveal the results of tradeoff studies with differing objectives. In the case of the Telstar series, higher rf power was traded off for increased linearity, life and reliability. The new transponders will have improved filtering, equalization and sensitivity. The individual power amplifiers produce the same amount of rated power as the Comstar satellites (see the table), thus keeping the dc power requirements low. This in turn permitted more mass for spare power amplifiers and 10 years of hydrazine (for station-keeping). Even without resorting to higher-efficiency thrusters and nickel hydrogen batteries, the new satellites have a lower mass than old Comstars, a measure of the payoff of satellite technology research.

Telstar mirrors the Comstar experience. Now spare TWTAs and improved nickel cadmium batteries are carried. In addition, solid-state power

amplifiers (SSPAs) are included thus producing a form of functional design redundancy.

Transponders may use either a TWTAs or a SSPA. For example, it may be more efficient to use a TWTAs for single-carrier-per-transponder applications (wideband digital or FM/TV) and the SSPA for multiple-carrier-per-transponder applications (SCPC, fractional transponder TDMA, two video carriers, etc.) to reduce the intermodulation (IM) noise. The coverage is similar to the earlier Comstar.

The systems will continue to function with all of the present 30 meter Comstar earth stations. The Telstar system will use the two AT&T 10 m stations (Merritt I., FL and Greenbelt, MD) and a new series of 7 to 12 meter stations which will be on or near customer premises. In the TV service the customer may either use an AT&T station or supply his own (often 4.5 to 10m).

Each transponder is capable of carrying 900 full voice circuits using conventional FDM/FM. Using com-

panded single sideband (CSSB/AM), this can be increased to 3900 full circuits (assuming sufficient satellite spacing, earth station G/T and single carrier per transponder). This contrasts with Comstar's 750 full circuits per transponder.

If an entire satellite is optionally loaded with large carriers the Comstar series would be rated at 18,000 full circuits and Telstar 3's at 21,600 to 93,600 full circuits. AT&T's initial application envisioned 32,000 full circuits in service by the time of Comstar/Telstar transition. AT&T has filed a tariff to offer Satellite Television Service (STS) transponders to the cable and broadcast industries (ABC-TV, CBS-TV, NBC-TV, Wold, etc.) Seven Comstar transponders are currently being used for this service) 1.544 Mb/s service is also available on special order.

The original 1980 FCC filing called for three satellites (\$113 million), three launches (\$90 million), satellite control facilities (\$17 million) and in-house support (\$7 million).

Summary Table

Parameter	Comstar	Telstar	Units
Up/downlink Frequency Bands	6/4	6/4	GHz
Transponders-Active	24	24	Transponders
Spare	0	8	Transponders
Remaining at 7 years	18	22	Transponders
Bandwidth	34	36	MHz
Eirp	31-34	31-34	dBW
Launches	1976, 76, 78-81	1983, 84, 85 & ?	
Launcher	Atlas Centaur	Delta 3920, STS, STS & ?	
Locations	87, 95 & 128	87, 95 & 128	West
Intended Lifetime	7	10	years
BOL Mass	884	653	kg
EOL Power	600	670	Watts
Experiments	18 & 28	none	GHz
Names (AT&T):	Telstar 301 302 303 304		
(NASA):	Telstar -A -C -D n/a		
Verification date	October 6, 1982		

RCA & Western Union: 14/12 GHz Satellite

By Walter L. Morgan
Consulting Editor
Communications Center of Clarksburg

These satellites operate with uplinks of 14.0-14.5 and downlinks of 11.7-12.2 GHz. These ranges are sometimes referred to as the Ku band; that designation is so broad that it is confusing since "Ku band" covers fixed satellite service, direct broadcasting (12.2-12.7 GHz) and the NASA TDRSS frequencies. RCA and Western Union have both filed for satellites in this frequency band. This means that every major satellite carrier (with the notable exception of AT&T) has now announced plans for this frequency range.

The filings with the Federal Communications Commission, which were used as a basis for this Satellite Notebook, pinpoint the launch dates for the RCA system in May and October 1985 and May 1987; a ground spare will be available by January 1988. Western Union's plans show the three satellites being launched at six-month intervals starting in the second quarter of 1985.

Each operator has requested three orbit slots. RCA desires that all of its satellites be placed between 73° and 88° West longitude, and would prefer one to be located at 83° West so that it could be colocated with the existing Satcom IV. Western Union asks that at least one of the satellites be placed in the arc between 92° and 106° West so that fifty-state coverage can be provided from one satellite. In contrast, RCA proposes to provide coverage to Alaska and Hawaii through an existing 6/4 GHz Satcom. Both systems could use the Thor-Delta, the Ariane or the Shuttle to launch the satellites.

Western Union has filed for three satellites to be known as Westar IX through XI. Unlike the Advanced Westar satellite, these satellites are designed for small, inexpensive earth stations to be installed on rooftops or in parking lots in industrial locations.

RCA sees a market for these satellites that is distinct from its conventional 6/4 GHz Satcom series. It argues in its application to the

FCC that if a customer needs very high reliability, this can be accommodated on the existing Satcom series. However, if the customer wishes to use an earth station in a downtown area, then 14/12 GHz satellite would be preferable.

RCA also envisions opportunities for small antennas in the range of 2 to 3 meters (6 to 10 feet) for video and data reception at hotels, motels, multiple-unit dwellings and hospitals. On-the-job training by satellite is also proposed, particularly in the health care area.

The RCA and WU satellites will have 16 transponders, eight on each polarization, of 54 MHz each. In this sense, they will resemble the Gstar and Anik C satellites. Both the RCA and Western Union designs include four spare transponders.

RCA's edge of coverage (eirp) for the 48 states is between 38 and 39 dBW using 20- and 30-watt tubes. Western Union does not reveal the power level, but has an end-of-life eirp requirement equal to or greater than 41 dBW at the edge of CONUS coverage and a maximum on-axis power of 48 dBW. This implies a 50-watt TWTA. The Alaska/Hawaii coverage will be at approximately 37 dBW end-of-life. Western Union also talks about having quarter- or half-CONUS coverage selectable for each of the

16 transponders. The power provided to these regional beams can be incrementally controlled. At least two transponders can be capable of providing coverage to Alaska and Hawaii for satellites located between 92° and 106° West.

When it comes to polarization, the proposed satellites reflect different approaches. RCA, like Gstar, inclines its polarization axes 26° with respect to the equator to minimize rain losses. Western Union adopts the more conventional orientation in which one axis is parallel to the equator and the other perpendicular. Western Union goes on to state that its design will be capable of switching the polarization of transponders from the ground, thereby easing the cofrequency adjacent satellite interference.

It is not surprising that the RCA spacecraft is body-stabilized and bears a striking resemblance to other members of the Satcom family. Western Union is flexible on stabilization type.

Western Union's satellites will cost about \$105 million, and the total launch cost will be an additional \$130 million. RCA estimates that the four satellites will total \$152 million, and by the time the launch insurance, TT&C and engineering support are added in, the total network will be worth approximately \$306 million.

Satellite Owner Name	RCA Satcom	Western Union Westar IX-XI
Orbit locations	See text	See text
Coverage	48 states	50 states
Alaska & Hawaii	2 transponders in certain satellites	
Transponders		
• Active	16	16
• Spare	4	4
TWTA Power Rating	20 & 30 watts	not stated (50 watts implied)
Lifetime (minimum)	10 years	10 years
Bandwidth	54 MHz	54 MHz
End-of-Life eirp		
• Edge of CONUS	38-39 dBW	41 dBW
• Maximum on-axis	—	48 dBW
Launcher		Delta 3920, Ariane or Shuttle

TDRSS

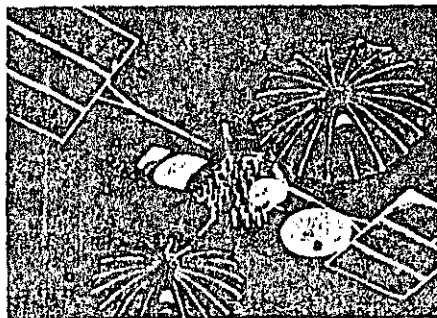
By Walter L. Morgan
 Consulting Editor
 Communications Center of Clarksburg

The Tracking and Data Relay Satellite System (TDRSS) is being assembled to permit the nearly continuous tracking of low-orbit satellites and space vehicles from the geostationary orbit. The user satellites transmit their data up to either of the two TDRS satellites in sight. Each of these satellites can track many low-orbit satellites simultaneously. The collected data is then relayed down to White Sands, New Mexico, where it is put into NASA's communications network (NASCOM). Some of the data may be distributed through domestic satellites to other NASA space operations centers.

These satellites are by far the most complex system ever flown commercially. The satellites use a combination of fixed, phased-array and large, movable antennas. Each of the two 4.9-meter (16-foot) antennas have a mass of 24 kg (53 lbm).

Space Communications Company (Spacecom), the owner/operator of the TDRSS system, is a partnership currently affiliated with Western Union (50 percent), Fairchild Industries (25 percent) and Continental Telecom (25 percent) for the purpose of operating the TDRS system under contract to NASA for ten years. By mid-1983 Western Union will have sold its share and the ownership will be the same as the American Satellite Co.

Under the December 14, 1982 reformation of the NASA/Spacecom contract, NASA will acquire all satellite capabilities (including the former Advanced Westar) for \$250 million. There eventually will be two operating (plus at least one spare) geostationary satellites in orbit at the same time.



Missions And Frequencies

Every satellite is launched with all the equipment to be either a TDRS or a fixed-service satellite. The FSS function was formerly known as Advanced Westar.

The TDRS mission requires operation at 2 GHz ("S" band) and 15/13 GHz (also called "Ku" band). The 15/13 GHz TDRS and the 14/12 GHz FSS functions share the same receivers and transmitters. Therefore, only one of these missions can be operated at a time. The TDRS and 6/4 GHz services can be operated simultaneously inside the same spacecraft shell.

Fixed Satellite Services

The Advanced Westar 14/12 GHz design used the large TDRS apertures in a unique switch beam design. When combined with TDMA this would have produced the first high speed SS/TDMA in orbit. This design approach makes more efficient use of the satellite-borne communications resources than with other systems currently in orbit. It is therefore the author's wish that when NASA's needs

have been met some meaningful tests and demonstrations of in orbit SS/TDMA capabilities be conducted. The 250 Mb/s rate could be replaced by 120 Mb/s equipment now becoming available for Intelsat and other systems.

The 6/4 GHz ("C" band) portion is patterned around the original Westar satellites of the 1977-79 vintage. The rated eirp at the edge of CONUS is 32.4 dBW. There is little likelihood that these satellites will be used for commercial service in the United States. There has been some interest in permitting the Island Nations of the South Pacific to make use of the idle capacity at 6/4 GHz in the TDRS West satellite.

The end of life dc power from each TDRS satellite is 1700 watts. The size of the satellite is staggering. For example, the solar arrays, when deployed, span the height of a six-story building. Several thousand commands are needed to deploy and beam steer the antennas.

The mission is also unique in its launch requirements. The first stage will use a new Shuttle and the Interim Upper Stage (IUS). The TDRS marks the start of the Shuttle-unique satellite designs. □

Summary Table

Parameter	Value & Units
Owner/Operator	Space Communications Co.
Customer	NASA
Launches	1983, 83 & 84
Control and TT&C Center	White Sands, N.M.
Orbit Locations Assigned	41, 79 & 171 West
Transponders	
2 GHz	2 at 26 Watts (+ 2 spares) SSA 1 at 28 Watts (using a min. of 8 of 12 3.5 watt TWTAs)
6/4 GHz*	12 at 5.5 Watts
14/12 GHz*	4 at 30 Watts (+ 2 spares) 2 at 1.5 Watts (+ 2 spares)
14.5-15.3/13.4-14.05 GHz	2 at 1.5 Watts (+ 2 spares) KSA 2 at 25 Watts (+ 4 spares)
Satellite mass in cargo bay	About 2250 kg
Minimum Lifetime (Fuel Dependent)	10 years
---*Ex-Advanced Westar--- Verification Date	January '83

Inmarsat

By Walter L. Morgan
Consulting Editor

Organization

The International Maritime Satellite Organization (INMARSAT) provides communications via satellite to the shipping and offshore industries around the world. Services include telephone, telex, facsimile and data communications. It is headquartered in London. The Director General is Olof Lundberg. It is financed by 38 nations with merchant fleets. More than 85% of the world's merchant shipping gross tonnage belongs to nations that are members of Inmarsat.

The United States is represented by the Comsat General Corporation (23.4% ownership). The Soviet Union is the second largest owner (14.1%) with the U.K., Norway, Japan and others with lesser ownerships. The investment in the network is about \$US250 million. The organization was created in 1979. Inmarsat took over the Marisat service on February 1, 1982.

Satellites

The present array of satellite facilities is:

- Atlantic: Marisat F1
Marecs-A
- Indian Ocean: Marisat F3 & Intelsat V-F5/MCS
- Pacific: Marisat F2

These facilities are leased from Comsat General (Marisat), the European Space Agency (Marecs) and Intelsat (the Maritime Communications Subsystem aboard Intelsat V-F5 and subsequent satellites). The second Marecs (bound for the Pacific) was lost on Ariane L5.

Shore Stations

The three Marisat stations (two in

the U.S. and one in Japan) have been joined by three more in 1982 and by 1985 there may be 18 more constructed.

Ship Terminals

The original Marisat terminal consisted of a 1.2 meter (4 ft.) antenna in a radome plus below-deck equipment to provide telephone, telex and data services. The follow-on satellites have been designed to be compatible with these stations. The number of terminals has grown from 1007 in February 1982 to more than 1550 by January 1983. Inmarsat has been considering both larger and smaller ship terminals to provide users with the choice of increased service or decreased cost.

Maritime Services

Conventional maritime communications involves the use of short-wave radio. This is an unpredictable service, and often can take 12 hours for the New York or London shipping office to reach its ship and another 12 to get a response. At the cost of operating a modern ship, this delay means the waste of both fuel and manpower if the message involves a change in port assignment, etc. Satellite communications have cut this delay to a fraction of a second (with the advent of direct dialing to a ship's telephone) and replaced static with clarity.

Making a ship-to-shore call involves the use of four separate frequencies. The ship-to-satellite link operates at 1.6 GHz. 4 GHz is used for the satellite-to-shore station where connections to the terrestrial telephone or telex network are made. The return path is at 6 GHz and 1.5 GHz.

The author placed the first ship-station-to-ship-station call using two Marisat satellites in 1976 at the IAF meeting in Anaheim, Calif. The call was placed via the Marisat Pacific satellite to the shore station at Santa Paula, Calif., then via land lines to the shore station at Southbury, Conn.,

Inmarsat Satellite

Satellite	Marisat	Marecs	Intelsat V/MCS
Owner	Comsat Gen'l	ESA	Intelsat
Manufacturer	Hughes	Brit Aero	Ford Aero
Mass at BOL (kg)	327	509	N/A
Lifetime (years)	7	7	7
First Launch	1976	1981	1982
Mid-band Frequencies, MHz & (bandwidth, MHz)			
Receive	1640.5 (4)	1641 (6*)	1640.25 (7.5*)
Transmit	6422 (4) 1539 (4) 4197 (4)	6422.5 (5) 1540 (5) 4197.5 (6*)	6421.25 (7.5) 1538.75 (7.5) 4196.25 (7.5*)
EIRP (dBW) in Each Band (dBW) @ Edge	27 18.8	34.7 16.6	32.8 21.2
Oceans Served	All	Atlantic	All
Number of Satellites	3	1†	4
Full Circuits	10	48	30
Lease/Satellite (\$US)	5M/3	60M/2	?
Stabilization	Spin	3-axis	3-axis
See <i>Satellite Comm.</i>		May 1981	June 1981

UNCLASSIFIED

January 1983

* Including 0.5 MHz for safety & rescue (distress).

† The second Marecs was lost on Ariane L5. A replacement will probably be launched in 1984 for the Pacific Ocean Region.

in the Persian Gulf. This was one of the first double-hop links and worked successfully. Today double-hop ship-to-ship links (via a shore station) are frequently made.

At one time, the Marisats were also used at UHF for service to the U.S. Navy. Fleetsatcom and Leasat (see "Satellite Notebooks" #5 & #12) have taken over this function, so more power is available for commercial services. All satellites provide global coverage at each frequency.


Marecs

This satellite is provided by the European Space Agency. Two (Marecs-A and -B) were constructed and launched by the Ariane. The second was lost on L5. ESA has proposed to assemble a replacement satellite (B2) from parts and Inmarsat is negotiating a fixed price. These maritime satellites are the second European design. The previous satellite concept (called Marots) was based on the Orbital Test Satellite (OTS). An enlarged

version, based on the European Communications Satellite (ECS or Eutelsat), is, naturally, called Marecs.

Intelsat V/MCS

842

Inmarsat is leasing a maritime communications sub-system (MCS) on the Intelsat V-F5 and the next three satellites in the series. Unlike the other satellites, the stationkeeping is more precise (as dictated by the fixed satellite services). 

Marisat

This is a spin-stabilized satellite produced by Hughes and owned by a consortium headed by Comsat General. Its characteristics are shown in the table. Marisat has demonstrated that there is a market for maritime communications satellite services. These satellites will continue to function beyond their nominal lifetime by making optimum use of the remaining fuel. Mobile satellites generally require little or no north/south stationkeeping fuel. Since the earth station must be capable of tracking (by virtue of the mobility of the station) it can also track the slow motion of the satellite.

Inmarsat Ship Station Standards

Units	A*	B†	C†	D†
Antenna diam. (m)	0.8-1.2	0.5	0.2	3
Fig. of merit (dB/K)	-4	-10 to -15	-19 to -26	+6

Services:

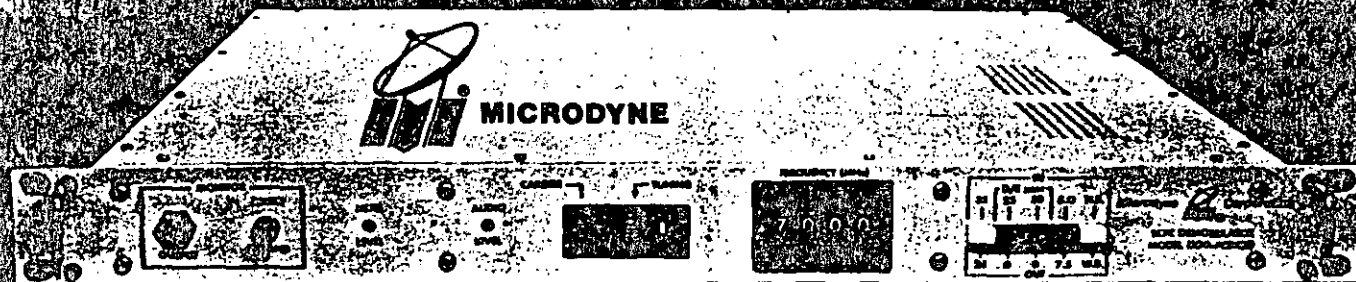
Voice				
Multichannel.....				X
1 channel.....	X			
Reduced quality.....		X		
Telex				
.....	X	X	X	X
Data:				
2400 baud.....	X	X	X	X
56 kb/s.....	X		(ship shore)	X
* Current standard			† Possible future standards	

Microdyne's new 1100-PCDR(5) is a tuneable Single Channel Per Carrier demodulator that provides you with access to a wide range of satellite transmission formats.

Synthesized 10 KHz step tuning makes crystal controlled units and plug-in cards obsolete! So expanding your radio programming was never easier — or more economical.

Find out more about Microdyne's revolutionary tuneable SCPC demodulator. Call 516/293-7788 and talk to the Tele-Wire satellite experts today — *distributors of radio broadcasting electronics and complete SCPC systems.*

**SUPPLY
CORP.**



Corporate Headquarters: 7 Michael Ave.
E. Farmingdale, NY 11735

Four Regional Distribution Centers
New York, Pennsylvania, Florida, Texas

UNISAT

By Walter L. Morgan
Consulting Editor

The satellite for this month has gone under a number of different names. At various times it was called UKSAT, Britsat and Halley. A more permanent name seems to be Unisat, which is derived from the corporate name. United Satellites Ltd. is a company formed by British Aerospace, General Electric Company (which includes the Marconi Company) and British Telecom (formerly the British Post Office).

This satellite is sometimes referred to as a direct broadcast satellite for the United Kingdom, as a business satellite, and at other times as a quasi-international service. In reality, it is a combination of all of these.

Direct Broadcasting

The direct broadcasting function to the U.K. will be carried out on two television channels on each satellite. The service selected from the list of five allocated to the United Kingdom at the 1977 World Administrative Radio Conference.

The frequency range for the BSS transponders is between 11.78 and 12.10 GHz. The maximum permitted eirp for this service is 65 dBW. The coverage of the 0.72 x 1.84 degree beams is shown in the figure. The TWTAs will be rated at 200 watts, producing an on-axis eirp of about 63.7 dBW.

Each satellite will be equipped with two direct broadcast transponders switchable to any two out of four of the five assigned television channels.

This satellite and its in-orbit spare will be located at 31° West longitude and may eventually be part of a large satellite collection at this longitude. (See "Satellite Notebook #13.")

The pattern for the direct television signal is basically the United Kingdom (within the 3 dB contours). As indicated in an earlier Satellite Notebook page, improved receivers and larger than anticipated (in 1977) antennas may well permit homes in other regions to view the BBC.

Transatlantic Business

The business service covers half the United States and most of Western

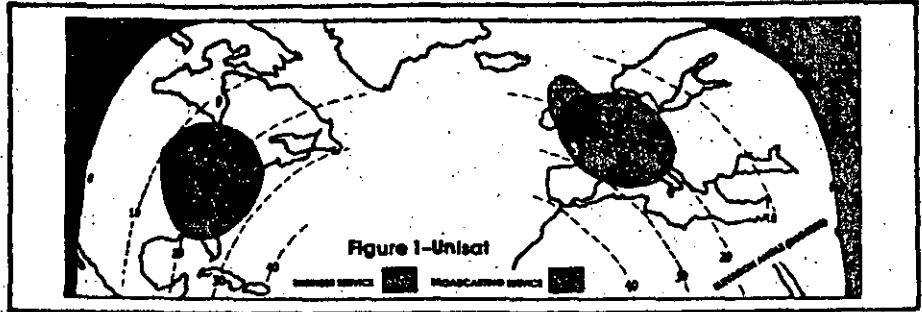


Figure 1-Unisat

Europe (see Figure 1.) Intelsat views this as both a threat and a promise. While it is authorizing Ford to procure long lead items to convert Intelsat V-As for providing a business service, it is investigating obtaining these services from Unisat. Later versions of Intelsat V1 might also be modified for business services.

The business frequency bands will be: uplinks at 14.0-14.5 GHz and European downlinks at 12.5-12.75 GHz; North American downlinks will be at 11.7-12.2 or 10.95-11.2 GHz. This is caused by the differing allocations in Europe and North America for broadcasting, fixed-satellite and terrestrial services. The intention is to provide services to small earth stations.

Each beam is approximately 1° by 3° and has an antenna gain of about 39 dBi. A 20-watt TWTAs of the type used on ECS produces an on-axis eirp of about 48 dBW.

Towards A Freer Market

The emergence of a private British satellite comes on the heels of the new Telecommunications Act and the authorization of an alternative common carrier within the United Kingdom. Mercury Communications Consortium is a joint venture of British Petroleum (BP), Cable & Wireless Ltd. and Barclay's Bank Ltd. While Mercury is primarily a terrestrial carrier, it is possible it may wish to use a satellite to interconnect various Mercury nodes

within the United Kingdom. Mercury already has announced plans to construct an earth station near London for trans-atlantic services. A single, smaller earth station might provide both domestic and international services at each of Mercury's nodes.

British Telecom has made cooperative arrangements with Satellite Business Systems in the United States for international traffic between the two countries. How this relates to British Telecom's dual responsibilities under the United Satellites Ltd. and Intelsat agreements (it is the signatory for the United Kingdom) will make interesting reading and a case study for future generations of students.

Price & Schedule

Three satellites have been ordered at a total cost of about \$190 million from British Aerospace, which will use the experience gained in the Marecs, Eutelsat (ECS) and L-Sat programs. An enhanced version of the ECS bus will form the basis of Unisat. The mission life will be seven years.

Reservations have been made for launching two of these satellites (and a back-up third) on the Shuttle using a spin-stabilized upper stage with launches scheduled for September and December, 1986, and February, 1987. Ariane reservations have been made for January-February, 1986, and June-July, 1986.

Summary Table

Operator	United Satellites Ltd.	
Launches	1987	
Satellite Family	Enhanced ECS	
Orbit locations	31	West
Lifetime	7	Years
Transponders	2 @ 60.7 dBW @ 27 MHz	(BSS)
(@ edge)	4 @ 44 dBW @ 36 MHz	(FSS)
Spares	2	(BSS)
	2	(FSS)
Satellite mass on orbit	850	kg (BOL)
Power capability	2300	W (BOL)
Coverage	U.K.	(BSS)
	Western Europe	(FSS)
	North America	(FSS)

Intelsat VI

By **Walter L. Morgan**
Consulting Editor
Communications Center of Clarksburg

The Intelsat VI design marks the return of the 108-member international telecommunication satellite organization to a spin-stabilized spacecraft after using the body-stabilized Intelsat Vs and V-As spacecraft. Hughes won the award for five spacecraft for \$700 million with an option for additional spacecraft, which may bring the total to 16 spacecraft and \$1,600 million. As in the case of recent Intelsat satellites, the VIs will carry hardware being provided by major subcontractors in Canada, France, Italy, Japan, the United Kingdom, and West Germany.

The satellite has a useful bandwidth of 3200 MHz and is rated as providing approximately 33,000 half-circuits even before the use of digital speech interpolation (DSI) which can double the capacity. In addition, television is carried in transponder 12 and SCPC in transponder 10.

Each Intelsat VI satellite will have 48 active transponders of which 38 are for use in the 6/4 GHz frequency range. Two of these (1'-2') lie below the normal 6/4 GHz band. The remaining ten are in the 14/11 GHz band.

This giant spacecraft will weigh 2180 kg at the beginning of life in geosynchronous orbit and have a diameter of 3.6 m. The basic design is an outgrowth of the Leasat bus (see "Satellite Notebook #12") with other features taken from the highly successful HS-376 series. The solar arrays will generate 2,100 watts of electrical power at the end of life.

The Intelsat VI will be 11.7 m (39 feet) tall. To pack this large spacecraft into the Shuttle or Ariane requires extensive folding of the antennas.

The antenna subsystem consists of a 3.2 m (10.5 foot) reflector for transmission at 4 GHz, a 2.0 m antenna for 6 GHz reception, 1.0 and 1.1 m reflectors for the spot beams at 14/11 GHz, and two global horns for 6/4 GHz operation.

The antenna patterns for the Atlantic Ocean region closely resemble those of the Intelsat V (see "Satellite Notebook #4"). There are three types of antenna patterns (hemi-

spheric, zone and spot beams). The major change is the addition of two more zone beams. The beams may be reconfigured after launch to optimize the coverage for the Indian and Pacific Ocean users. This permits the six-fold reuse of frequencies in the zone and hemi-beams (compared with four for Intelsat V).

Dual polarized global beams are also available at 6/4 GHz using horn antennas. The spot beams operate at 14/11 GHz and cover approximately the same areas as those of Intelsat V.

The small zone beams cover portions of North America and Europe. Zones may also be reconfigured to closely simulate the Intelsat V operation.

The Intelsat VI frequency plan is shown in the table. Cross-strapping between the 6/4 GHz and 14/11 GHz frequency bands is made possible by the use of common 4 GHz intermediate frequency and static bypass switches. For example, an uplink at 6 GHz may become an 11 GHz downlink. Satellite-switched time division multiple access is also available for certain hemi- and zone-transponder combinations. This marks the first use of SS/

TDMA on an international satellite. All traffic from the beam must follow a consistent path unless the SS/TDMA is used.

The 4 GHz TWTAs have power ratings ranging from 5.5 watts to 16 watts. Solid-state power amplifiers (GaAs FET transistors) can be used for the North American and European zone beams. The 11 GHz TWTAs are rated at 8.5 watts. For every two active transponders, there is one spare power amplifier at 4 GHz and two at 11 GHz.

A liquid bipropellant subsystem will provide the functions of the apogee kick motor and orbit station-keeping and attitude control. Each of the two apogee thrusters are rated at 490 Newtons. The stationkeeping thrusters are rated at 22 Newtons.

The initial Intelsat VI satellite will be delivered late in 1985 and launched early the following year for Atlantic Ocean regional service. The satellites will be capable of being launched from either the Shuttle or the Ariane 4. In the case of the Shuttle, the deployment uses the same frisbee mode described in "Satellite Notebook #12." The mission lifetime is ten years.

INTELSAT VI FREQUENCY PLAN

Number	Center Freq. (GHz)	Bandwidth (MHz)	Hemi Beam (RHC)	Zone Beam (LHC)	Spot Beam (LIN)
1'-2'	3.685	72	E & W		
1-2	3.7425	72	E' & W'	1'-4'	
1-2	10.9925	77			E & W
3-4	3.825	72	E' & W'	1'-4'	
3-4	11.075	72			E & W
5-6	3.905	72	E & W	1-4	
5-6	11.155	72			E & W
7-8	3.985	72	E & W	1-4	
7-8	11.495	72			E & W
9	4.055	36	E & W	1-4	
9-12	11.618	150			E & W
Global Beams					
LHC RHC					
9	4.055	36	X	X	
10	4.095	36	X	X	
11	4.135	36	X	X	
12	4.175	41	X	X	

UPLINKS**

(For 4 GHz Downlinks)

All are 2.225 GHz higher except 7-8 & 9-12 which are 2.8 GHz higher in frequency.

(For 11 GHz Downlink)

All are 3.050 GHz higher in frequency.

* Access to the SS/TDMA is provided for these beams for 6/4 GHz service.

** The uplink polarizations are orthogonal to the downlinks.

Verification Date: April 1983

American Satellite System

By **Walter L. Morgan**
Consulting Editor
Communications Center of Clarksburg

If one was to divide satellite carriers into two groups — old-line common carriers and the new entrepreneurs — American Satellite Company (ASC or Amersat) would defy classification. One of its two parents is Continental Telecom, Inc. (Contel), one of the largest and oldest independent telephone companies. The other is Fairchild Industries, which built the ATS-6 and still constructs spacecraft. ASC has demonstrated an ability to find traffic in areas that others have ignored or ill-served. It now operates over 130 earth stations (mostly two-way) carrying mainly digital traffic through a collection of transponders which it owns on Westar satellites.

Several years ago it acquired 20 percent of the Westar system capacity. It now has the equivalent of over 18 transponders. In 1981 it surveyed its future and decided it wanted so many additional transponders that it needed its own series of satellites. In December 1981, it filed an application for two on-orbit and one ground spare satellite. Although the application has yet to be approved by the FCC, the company has entered into an approximately \$100 million contract with RCA Astro-Electronics for the construction of two satellites, certain ground equipment and long lead items for optional additional spacecraft.

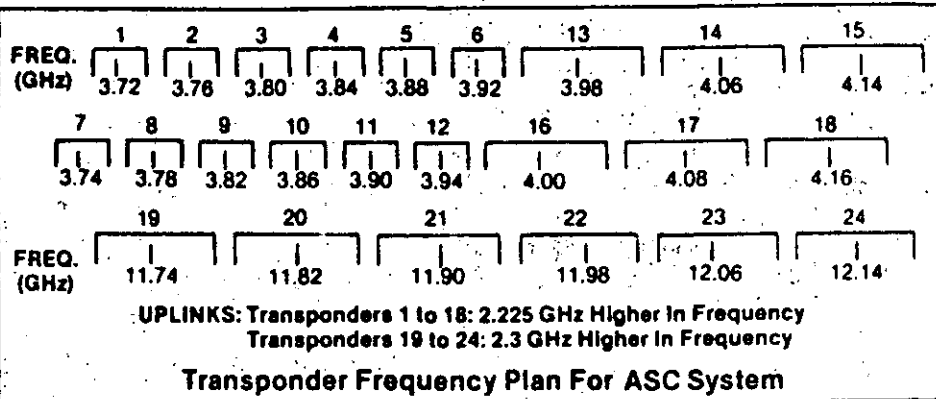
Delivery of the spacecraft is due in May, 1985, for a September 1985 Shuttle launch. The second spacecraft is scheduled for launch in late 1986. They may be launched on either the Shuttle, the Ariane or the Delta.

The transfer orbit mass (using the PAM-D) will be 2,765 lbs. Upon reaching the geostationary orbit, its mass will be about 1,467 lbs.

The assigned orbital locations are 81° and 128° West longitude. The stationkeeping tolerance is ±0.05° East/West and North/South. Full operational capability will be provided during eclipse.

The spacecraft operate in both the 4 and 14/12 GHz fixed satellite service bands. In the case of ASC, the transponders are divided as shown in the figure between 36 and 72 MHz bandwidths. The total r.f. power is

Summary Table			
Parameter	6/4 GHz	14/12 GHz	Units
Transponders-Active (spare)			
at 36 MHz	12 (14)	0	
at 72 MHz	6 (8)	6 (7)	
equivalent	24	12	at 36 MHz
eirp at Edge of Coverage			
at 36 MHz	34		dBW
at 72 MHz	36	42	dBW
G/T of satellite at edge of coverage		- 2	dB/K
Launches		1985 & 86	
BOL mass		1,467	lbs.
EOL (10 years) power (Summer Solstice)		1,215	watts
Verification Date		April, 1983	



about 300 watts in 1500 MHz of assigned bandwidth (including guard-bands). The 36 MHz 4 GHz transponders use a 8.5-watt solid-state power amplifier. The 72 MHz transponders use 16.6- and 17.0-watt TWTAs at 4 and 12 GHz, respectively. The redundancy plan calls for 14 (for 12) SSPAs, 8 (for 6) 16.6-watt, and 7 (for 6) 17-watt TWTAs. All of the 6/4 GHz transponders provide service to all 50 states and Puerto Rico.

The command link will be encrypted to prevent unauthorized access to the satellite. The more mass-efficient nickel hydrogen energy storage cells and electrothermal hydrazine thrusters will be used. The anticipated (fuel-limited) lifetime is 8.5 years. The equipment is designed for at least 10 years of life. The attitude control system uses the RCA three-axis body stabilization design.

In the tradeoff between mass, power, lifetime and features, several potentially interesting optional aspects of the original request for proposals were dropped. These included on-board signal processing, switching, and cross-band coupling.

The ASC network consists of both small (56kb/s to 1.544 Mb/s) and large (64 Mb/s TDMA trunk) stations. The solid-state power amplifiers have the advantage of improved linearity, thus permitting more SCPC carriers per transponder due to the marked reduction in the intermodulation noise power. This improved linearity is traded off against the lower DC-to-r.f. conversion efficiency. In addition to digital data, ASC provides voice, data, teleconferencing, digital audio and some video capacity.

The TT&C center equipment will be provided by Fairchild Space.

AUSSAT

By Walter L. Morgan
Consulting Editor
Communications Center of Clarksburg

The Australian national communication satellite system will consist of three in-orbit satellites and a network of earth stations. The project is managed by Aussat Proprietary Ltd. Service will be initiated with the Aussat satellite launch.

The Aussat coverage includes Australia and Papua New Guinea. The Papua New Guinea (PNG) beam also includes New Britain and New Ireland; Australia is covered in its entirety by two identical national Australian (NA & NB) beams. Individual spot beams provide service to western Australia (WA), central Australia (CA), northeast Australia (NE), and southeast Australia (SE) as shown in the map.

The specified coverage areas attempt to cover one quarter of the continent each. Aussat Proprietary Ltd. has established the coverage areas to ensure service to the more sparsely populated regions as well as urban. A larger earth station may be needed in these areas.

These are all 14/DBS GHz satellites capable of being used for SCPC, FDM/FM/FDMA, TDMA and video. Simultaneous video and SCPC may be carried in the same transponder. The primary services will be voice, data, and video.

There are a total of 15 active transponders using 12 and 30 watts. There are 2 spare TWTAs at each power level. Each transponder is 45 MHz wide. The eirp levels vary between 36 and 47 dBW.

The spacecraft are being assembled by the Hughes Aircraft Company using the standardized HS-376 bus. The contract received by Hughes includes three spacecraft and certain terrestrial facilities, such as TTC&M earth stations and a satellite control center. Amalgamated Wireless (Australasia) Ltd., as a subcontractor to Hughes, will provide elements for four TTC&M stations. Many of the communications earth stations will be fabricated by Australian companies. In particular, Mitsubishi Australia Ltd. will supply eight major earth stations to Aussat Proprietary Ltd.

Each satellite has a beginning-of-life mass of approximately 650 kg. The end-of-life power generation capability is 871 watts. The basic outward difference between this satellite and

others in the HS-376 class is the large grouping of antennas. Three reflectors are used. The smaller one covers the widest area (the national beam). The others are used to form the spot beams mentioned above. The spacecraft is inverted from the normal northern hemisphere HS-376 orientation with the antennas being down under on the southern end of the satellite.

There are several classes and sizes of earth stations. The direct-to-home service is referred to as the Home-stead and Community Broadcasting Satellite Service. Typical earth stations have an antenna diameter of under 1.5 meters. Two-way telecommunications (primarily voice) are also available to connect the various rural portions of Australia.

Direct TV services will also be available. A large market in home stations is anticipated. The service will be at the medium power levels (eirps in the 47 dBW range vs. the 63-64 dBW allocated for true BSS services from 98° and 128° East by the WARC-77). In this respect it more closely resembles the Telesat Canada and USCI services

than the proposed Satellite Television Corporation's.

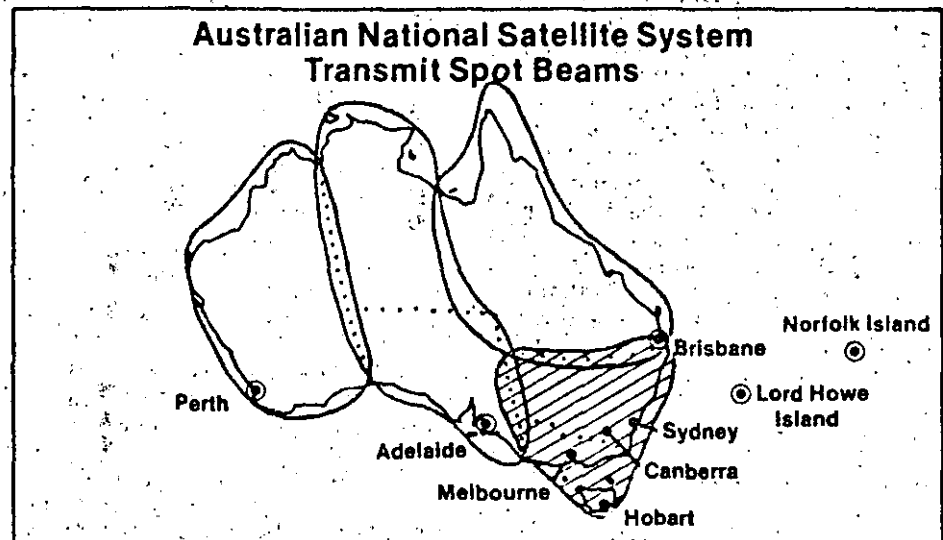
Telecom Australia has contracted for 65 earth stations to permit automatic connection to the terrestrial telecommunications network. In addition, five transportable emergency stations are being procured.

Aussat differs from the previous satellites in the HS-376 series in that the antenna subsystem now consists of three separated antennas. The smallest antenna (0.6 meters in diameter) forms the national beam, whereas the two large antennas (1.0 and 1.1 meters) provide spot beam service. There is room within the shroud of the Delta launch vehicle to accommodate the antennas in the in-service position.

The attitude control system uses a beacon earth station as its reference. For further information, see "Satellite Notebook #16."

Two launches have definitely been scheduled on the Shuttle. These are planned for July and October, 1985.

The assigned orbital stations are 156°, 160° and 164° East longitude. □



AUSSAT Summary Table

Name of Operator	Aussat Proprietary Ltd.
Manufacturer & Family	Hughes HS-376
Mass at BOL (kg)	650
Lifetime (minimum fuel)	7 years
Planned Launch Date	1985
Launch Vehicle	Shuttle or Ariane
Frequency Bands	Uplink 14.0 - 14.5 GHz
	Downlink 12.25 - 12.75 GHz
No. of TWTAs	Active 11 @ 12 watts
	4 @ 30 watts
Stationkeeping (E/W & N/S)	± 0.05 degrees
Locations	156°, 160° & 164° East
Solar Array Power	1200 watts (BOL)
	871 watts (EOL)
Verified	June 1983.

Mexico

By Walter L. Morgan
Consulting Editor
Communications Center of Clarksburg

The new Mexican Communications System, called Morelos, uses satellites that have gone under various names such as Ilhuicahua, Mexsat, Satmex and Mexico. They are also occasionally referred to as SMS-T1 and T2 (for Sistema Mexicano de Satellite). The satellite system is currently named after Jose Maria de Morelos y Pavon, the "servant of the people and the liberator" of Mexico.

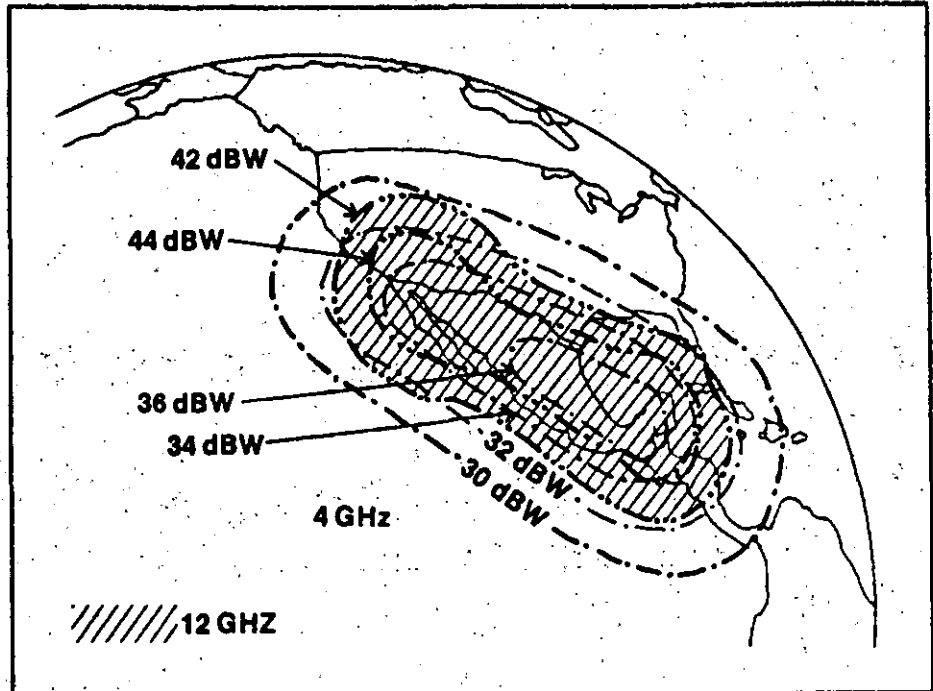
The history of long-distance television distribution in Mexico had its first major milestone in 1968, when a microwave system was installed. In 1980, it was decided to expand the system by leasing capacity on Westar III. This lasted until Intelsat IV moved to 53° West longitude to provide service to Mexico. (see *Satellite Communications Magazines*, January, 1983, pg. 48, for a coverage map).

Contracts have been let for the construction and launch of two satellites. Hughes Communications International received a \$92 million award, which includes the master control station and training. A contract for \$11.2 million for the PAM upper stage and \$24 million contract for two Shuttle launches have also been signed.

The Export-Import Bank will guarantee a \$127.5 million loan to Nacional Financiera, S.A., the Mexican government agency. Repayment will be in 20 semi-annual installments beginning March 31, 1986. Competition for the spacecraft was between Hughes, Ford, RCA, and the team of British Aerospace & Matra. The awarding agency was the Secretaria de Comunicaciones y Transportes. These satellites will further the social communications policies of the government of Mexico.

Educational television services, including health, family planning, will be provided by the four very wideband transponders at 14/12 GHz using a single polarization. Television distribution (to existing and future television stations) and telephony will be done at 6/4 GHz. A national data service will also be established on these frequencies.

This will be Hughes' first hybrid satellite. The HS-376 satellite will be modified to carry both 6/4 and 14/12 GHz services. There will be a total of



SUMMARY TABLE

Parameter	Value and Units
Owner/Operator	Secretaria de Comunicaciones y Transportes (Mexico)
Manufacturer & Family	Hughes HS-376
Planned Launch Dates	1985, 85
Launch Vehicle	Shuttle/PAM
Lifetime (Fuel Dependent)	9 years
Orbit Locations	113.5° & 116.5° West
Transponders: 6/4 GHz	12 @ 36 MHz @ 7W 6 @ 72 MHz @ 10.5 W
14/12 GHz	Spare tubes — 2 each 4 @ 108 MHz @ 20W Spare tubes — 2 each
Satellite Mass at BOL	666 kg
Verification Date	June, 1983

22 transponders occupying the bandwidth of 36 standard transponders. The Hughes 20-watt 12 GHz tubes will be the same as those used on SBS-4.

The breakdown of the transponder count, power and frequencies are given in the table. The conventional HS-376 reflector will be used for the 6/4 GHz services and 12 GHz transmissions. A separate planar array is mounted in front of the transmit feeds for reception at 14 GHz (this array is 150 x 91 cm).

There are or will be eleven television uplink cities. The earth station complex already consists of nearly 200 earth stations operating with Intel-

sat IV. The reception equipment, particularly for educational television, will make use of new inexpensive K-band earth stations. Telephone service will be provided to 13,000 villages at 6/4 GHz. The coverage pattern map is shown in the figure.

This HS-376 has a beginning-of-life mass in geosynchronous orbit of 666 kg. By the end of its nine year lifetime, it will consume 145 kg of fuel. It is scheduled for launch on the Shuttle in April and September, 1985. The apogee kick motor will be a Morton-Thiokol Star 30B.

The tracking, telemetry and control station will be established at Iztapalapa (near Mexico City).

Geostationary Satellite Locations

By Walter L. Morgan
Communications Center of Clarksburg

The Tables in this Satellite Notebook list the various satellites by location (in longitude), downlink frequency (in GHz), the name of the satellite and the year of the launch. East longitudes are designated by the letter E and West by W. While almost all Western commercial satellites adhere closely to their assigned location, some of the experimental, meteorological and military satellites may move to unpredictable locations at any time. In the launch year column, the number 0 indicates that the actual date of launch cannot be predicted with sufficient accuracy.

In the preparation of this listing, satellites known to be non-functional were deleted. Additional satellites will reach the end of their life in the near future. Thus, the number of operable and present satellites may be a slight overstatement. The listings for new satellite systems are based on announcements and filings. Within the United States, the new satellite system filings received by the Federal Communications Commission after April 1983 have, in general, been excluded. A substantial number of additional filings are expected to arrive at the Federal Communications Commission by Nov. 7.

This list places most of the U.S., Canadian and Mexican satellites in the locations recently announced by the Federal Communications Commission. During the next few years, some satellites may be moving to the location indicated in this table. Moves for satellites already in orbit will take place either at the convenience of the system operator or when another satellite is launched into a nearby orbit assignment. Anik C2 is temporarily located at the position to be occupied by GSTAR A-2. It will return to the location shown in 1984. A few satellites (for example, Westar V), are shown at their pre-move locations.

Reconsideration requests have been received on the FCC orbit location order (83-186). The final locations may be changed further.

The Table does not include dead satellites, pieces deployed and left in the geosynchronous orbit or propulsion stages. The Global Satellite Station charts illustrate these tables. The data is current as of November 1, 1983

LOCATION / GHZ DOWN NAME OF SATELLITE YEAR

LOCATION	GHZ DOWN	NAME OF SATELLITE	YEAR	LOCATION	GHZ DOWN	NAME OF SATELLITE	YEAR
E000	14, 5, 1.7	METEOSAT-2	81	E085	3.6-3.9	STATSIONAR-03	0
E001-7	4	INTELSAT RETIRED	0	E085	2.8-1.8	VOLNA-8	0
E003	7	SKYNET IIB	74	E090	4, 7	GORIZONT-2	79
E003.5	3, 7, 12, 20	SICRAL 1A	87	E090	11	LOUTCH-3	0
E004	4, 7, 12	TELECOM-1C	85	E090	3.65-3.95	STATSIONAR-06	0
E005	12, 12	TELE-X	88	E090	3, 1.6, 1.6	VOLNA-8	84
E010	11 & 12	EUTELSAT 1	83	E092	12	PRC-3	88
E010	14, 5, 1.7	METEOSAT-1	77	E094	2.5, 4	INSAT-1B	83
E010	11	OTS-2	78	E095	11 & 13	CSDRN	0
E012	4	PROGNOZ-2	0	E095	3.4-3.95	STATSIONAR-14	0
E013	12, 35-757	EUTELSAT 1-2	83	E099	7.14	EKRAN-3	79
E013	20 & 40	ITALSAT	88	E099	7.14	STATSIONAR-T	0
E0137	7	SIRCAL	87	E100	7.14 & 3	EKRAN-9	82
E014	4	NIGERIAN NAT SAT-1	0	E101	7.14	EKRAN-10	83
E015	4 & 12	AMS-1	86	E101	0.714	EKRAN-7	81
E015	4 & 12	AMS-2	86	E102	0.136 & 4	APPLE	81
E017	11 & 12	SABS	84	E108	4	PALAPA-B1	83
E019	2.5 & 4	ARABSAT-1	84	E110	12 & 2	BS-2A	84
E020	4	NIGERIAN NAT SAT-2	0	E110	12 & 2	BS-2B (SPARE)	85
E021.7	4, 7	GORIZONT-3	79	E110	12	BS-3	87
E022	3, 7, 12, 20	SICRAL 1B	87	E110	12	YURI (BS-1)	78
E023.5	11, 12, 20	DFS-1	86	E113	4	PALAPA-B2	84
E026	2.5 & 4	ARABSAT-2	84	E118	4	PALAPA-B3	0
E028.5	11, 12, 20	DFS-2	87	E120	20	NTT-1	87
E033	4	RADUGA-11	82	E120	20	NTT-2	96
E035	7	GALS-6	84	E125	4.00-4.200	STW-1	83
E035	137, 2.3	GEOS-2	78	E129.5	1, 1, 11, 34	KIKU-2	77
E035	4	PROGNOZ-3	0	E130	4 & 20	CS-2A	83
E035	3.4-3.9	RADUGA-09	81	E130	EXP	ETS-5	87
E035	3.6-3.9	STATSIONAR-02	0	E130	7	GALS-5	84
E040	3.4-3.95	STATSIONAR-12	0	E130	3.4-3.95	STATSIONAR-15	0
E041	7	SKYNET IV	84	E135	4 & 20	CS (SAKURA)	77
E045	7	GALB-2	0	E135	4 & 20	CS-2B	83
E045	11	LOUTCH-P2	0	E135	4 & 20	CS-3A	88
E045	3.4-3.7	STATSIONAR-09	0	E135	4 & 20	CS-3B	88
E045	2.8-1.5	VOLNA-3	0	E140	1, 5, 1.7	GMS-3 (HIMIWARU)	84
E048	3.4-3.9	RADUGA-08	80	E140	10	LOUTCH-4	0
E051	7.14 & 3	EKRAN-8	82	E140	3.65-3.95	STATSIONAR-07	0
E053	4, 7 & 11	GORIZONT-5	82	E140	3, 1.6, 1.6	VOLNA-6	0
E053	11	LOUTCH-2	0	E143	1, 5, 1.7	GMS-2 (HIMIWARU-2)	81
E053	3.65-3.95	STATSIONAR-05	0	E158	12.25-75	AUSSAT-1	85
E055.5	11	LOUTCH-2 LATER	0	E160	12.25-75	AUSSAT-2	85
E057	1.5, 4, 11	INTELSAT IO-SPARE-1	0	E182	1.36 + .5	ATS-1	7
E057	4	INTELSAT IVA-F2	78	E184	12.25-75	AUSSAT-3	0
E058	0.714	EKRAN-6	80	E170	4	PAC. AREA SAT SYS-A	8
E058	3, 1.5, 1.5	VOLNA-4	0	E170	4 & 12	PAC. AREA SAT SYS-B	87
E080	2, 7	DSCS-2-F04	73	E170	3.4-3.7	STATSIONAR-10	0
E080	2, 7	DSCS-3-F4	84	E172	.25	FLEETSATCOM-4	80
E080	1.5, 4, 11	INTELSAT IO-MPIPRI	0	E172	44	FLTSATCOM-B	86
E080	4 & 11	INTELSAT V-F1	81	E174	4	INTELSAT IVA-F8	78
E080	1.5, 4 & 11	INTELSAT V-F7	83	E174	4, 11	INTELSAT PO-PRI	0
E083	1.5, 4, 11	INTELSAT IO-PRUMP	0	E174	4.8-11	INTELSAT V	0
E083	4 & 11	INTELSAT V-F4	82	E175	2, 7	DSCS-2-F08	77
E083	1.5, 4 & 11	INTELSAT V-F5	82	E175	2, 7	DSCS-3-F2	83
E084.5	1.5, 4	MARECS-C	85	E175	2, 7	DSCS-WP	0
E085	4, 12	PRC-1	88	E178.5	.25	LEASAT-2	84
E085	14, 12	SIRIO-1	77	E178.5	1.5 & 4	MARISAT-PACIFIC-102	78
E086	1.5, 4, 11	INTELSAT IO-SPARE-2	0	E177.5	1.5, 4	MARECS-2B	84
E087	2, 7	DSCS-2-F12	78	E179	2, 7	DSCS-2-F13	79
E070	0.137, 1.7	GOMS	0	E179	4	INTELSAT IVA-F3	78
E070	4	STW-2	85	E179	4, 11	INTELSAT PO-SPARE	0
E072.5	.25	FLEETSATCOM-2	79	E179	4 & 11	INTELSAT V, VA & MCS	0
E073	1.5 & 4	MARISAT-INDIAN-103	77	W001	4	INTELSAT AO-SPARE 4	0
E075	44	FLTSATCOM-B	86	W001	4	INTELSAT IV-F4	72
E075	.25	LEASAT-1	84	W001	4	INTELSAT IV-F8	74
E077	4	PALAPA-A2	77	W001	1.5, 4 & 11	INTELSAT V-F9	83
E080	SHF	COSMOS-1366	82	W001	7	SKYNET A	84
E080	3.95-4.00	POTOK-2	0	W004	4	INTELSAT AO-SPARE 5	0
E080	4, 12	PRC-2	87	W005	4, 7 & 12	TELECOM-1B	83
E080	4	PROGNOZ-4	0	W006	4, 7 & 12	TELECOM-1A	83
E080	3.6-3.9	STATSIONAR-01	0	W011	3.4-3.95	STATSIONAR-11	0
E080	3.4-3.95	STATSIONAR-13	0	W011.33	4	SYMPHONIE-2	75
E083	4	PALAPA-A1	78	W011.45	4	SYMPHONIE-1	74
E085	11 & 13	ESDRN	0	W013	2, 7	DSCS-2-F14	79
E085	7	GALS-3	0	W013	2, 7	DSCS-3-F1	82
E085	4, 7 & 11	GORIZONT-8	82	W013	2, 7	DSCS-AO	0
E085	11	LOUTCH-P3	0	W013.5	3.65-3.95	STATSIONAR-04	0
E085	3.4-3.9	RADUGA-10	81	W013.5	1.5	VOLNA-2	0
				W014	11	LOUTCH-1	0
				W014.4	3.95-4.00	POTOK-1	0
				W014.5	4, 7	GORIZONT-7	83
				W014.5	4, 7	GORIZONT-4	80
				W015	1.5 & 4	MARISAT-ATLANTIC-101	78
				W016	11 & 13	WSDRN	0
				W018	2, 7	NATO IIB	77
				W018	7	NATO IV	7
				W018.5	1.5, 4, 11	INTELSAT AO-MAJ-2	0
				W018.5	4	INTELSAT IVA-F1	0
				W018.5	1.5, 4, 11	INTELSAT V-F6	0
				W018.5	1.5, 4 & 11	INTELSAT V-F8	83
				W019	12	HELVESET-1	85
				W019	12	HELVESET-2	87

LOCATION GHZ DOWN NAME OF SATELLITE YEAR

W019	12, 12, 30	L SAT 1	86	W087	12	SATCOM-K2	85
W019	11.7-12.1	LUXBAT	88	W088.6	4	TELSTAR 303	85
W019	11.7-12.5	SARIT	86	W089	12.2-12.7	CUBA	0
W019	12	DF-1A	85	W089	12	SBS-4	84
W019	12	TDF-1B	87	W091	12.2-12.7	CANADA-BSS	0
W019	12	TDF-1C	89	W091	4 & 12	SPACENET-3	85
W019	12	TDF-2	90	W091	4	WESTAR III	79
W019	12	TV-SAT-A3 F1	85	W092	.14, .4, 1.7	GOES-3	78
W019	2.3, 12	TV-SAT-A5	90	W092.5	12.2-12.7	CARIBBEAN	0
W021.5	4	INTELSAT AO-DOM&MCS	0	W093.5	4	GALAXY III	83
W021.5	4, 11	INTELSAT VA-F1	84	W094	12.2-12.7	ARGENTINA	0
W023	.25	FLEETSATCOM-3	80	W095	12.2-12.7	ECUADOR	0
W023	44	FLTSATCOM-B	86	W095	12	SBS-3	82
W023	.25	LEASAT-4	85	W095.0	4	COMSTAR D2	76
W023	2, 7	NATO IIC	78	W095.9	4	COMSTAR D1	76
W024	4	PROGNOZ-1	0	W096	12.2-12.7	BERMUDA	0
W024.5	4, 11	INTELSAT AO-PRI	0	W096	4	TELSTAR 301	83
W024.5	4 & 11	INTELSAT V-F3	81	W097	12	SBS-2	81
W024.5	4 & 11	INTELSAT VA-F3	84	W098.5	4	WESTAR VIII	85
W025	7	GALS-1	0	W099	2, 7	DSCS-2-F01	71
W025	11	LOUTCH-P1	0	W099	12.2-12.7	PARAGUAY	0
W025	3.4-3.9	RADUGA-07	80	W099	12	SBS-1	80
W025	.137 & 1.7	SIRIO-2 REPLACEMENT	85	W099	4	WESTAR IV	82
W025	3.4-3.58	STATIONAR-08	0	W099.9	.24, .4, 38	LES-9	76
W025	.2 & 1.5	VOLNA-1	0	W100	20	ACTS-1	0
W026	1.5, 4	MARECS-ATL1	81	W100	.25	FLEETSATCOM-1	78
W027.4	4 & 11	INTELSAT V-F2	80	W100	44	FLTSATCOM-B	86
W027.5	1.5, 4, 11	INTELSAT AO-SPARE 2	0	W100	.25	LEASAT-3	86
W030	2, 7	NATO IIIA	78	W101	12.2-12.7	USA-BSS	0
W031	12.2-12.7	FALKLANDS	0	W102	12.2-12.7	BRAZIL	0
W031	4	INTELSAT AO-SPARE 1	0	W103	12.2-12.7	COLUMBIA	0
W031	11 & 12	UNISAT-1	86	W103	12	GSTAR A-1	84
W031	11 & 12	UNISAT-2	86	W104	12.2-12.7	VENEZUELA	0
W031	11 & 12	UNISAT-3	87	W104.5	4	ANIK D1	82
W034	12.2-12.7	GUYANA & JAMAICA	0	W105	.136, 4	ATS-3	67
W034.5	4, 11	INTELSAT AO-MAJ-1	0	W105	12	GSTAR A-2	84
W034.5	4	INTELSAT IVA-F4	77	W105.4	.24, .4, 38	LES-8	76
W037.5	11	ORION-1	86	W106	12.2-12.7	CHILE	0
W038-44	4	INTELSAT RETIRED.	0	W106	7	NATO I	70
W041	2+, 13	TORS SPARE	84	W106.3	.14, .48, 1.7	SMS-2	75
W041	2.2 & 13	TDRS-F1	83	W107.5	12	ANIK C1	84
W041	2.2 & 13	TDRS-F2	83	W108	.14, .5, 1.7	GOES-2	77
W042	12.2-12.7	GRENADE	0	W108	.8, 7	M-SAT	87
W045	12.2-12.7	BRAZIL	0	W108	7	NATO II	71
W045	.25	FLEETSATCOM-5	81	W109	4 & 12	ANIK B	78
W047	11	ORION-2	86	W110	4	ANIK D2	84
W050	11	ORION-3	87	W110	12.2-12.7	USA-BSS	0
W053	4	INTELSAT AO-SPARE 3	0	W112.5	12	ANIK C2	83
W053	4	INTELSAT IV-F1	75	W113.5	4 & 12	MEXICO-1	85
W053	4	INTELSAT IV-F7	73	W114	4	ANIK A2	73
W055	12.2-12.7	ARGENTINA	0	W114	4	ANIK A3	75
W056	11, 12	ISI-1	0	W115	12.2-12.7	ANDEAN BSS	0
W057	12.2-12.7	FALKLANDS	0	W116.5	4 & 12	MEXICO-2	85
W057	UMF, 7	TACSAT-2	0	W117.5	12	ANIK C3	82
W058	11, 12	ISI-2	0	W119	4	SATCOM I	75
W060	4	SBTS-A4	88	W119	4	SATCOM II	76
W061.5	12.2-12.7	USA-BSS	0	W119	12.2-12.7	USA-BSS	0
W064	12.2-12.7	BRAZIL	0	W120	12	USAT-2	86
W065	4	SBTS-A-2	85	W122	4 & 12	SPACENET-1	84
W065	4	SBTS-A3	88	W123	4	WESTAR V	82
W067	4	SATCOM VI	85	W124	12	SBS-5	86
W069	12.2-12.7	AMEGO-1	0	W125	.8, 1.5, 12	MOBILSAT 2	87
W069	4	SBTS A-1	85	W125	4	TELSTAR 304	85
W069	4 & 12	SPACENET-2	84	W126	12	SATCOM-K3	85
W069.7	.137	ATS-5	89	W127	12.2-12.7	AMEGO-3	0
W070	44	FLTSATCOM-B	86	W127	4	COMSTAR D4	81
W070.5	12.2-12.7	CANADA-BSS	0	W128	7	DSCS-2-F15	82
W071.5	12.2-12.7	URAGUAY	0	W128	4 & 12	ASC-1	85
W072	4	SATCOM IIR	83	W129	12.2-12.7	CANADA-BSS	0
W072.5	12.2-12.7	CANADA-BSS	0	W129	.13, .5, 1.7	GOES-1	75
W073.5	4	SATCOL-1	0	W130	12	ASC-2	86
W074	12.2-12.7	BRAZIL	0	W131	4	SATCOM IIR	81
W074	4	GALAXY III	84	W132	12	RAINBOW-1	86
W075	0.4, 1.7 & 2	GOES-5	81	W134	4	GALAXY I	83
W075.4	4	SATCOL-2	0	W135	2, 7	DSCS-2-F11	78
W076	4	TELSTAR 302	4	W135	2, 7	DSCS-3-F3	83
W077	12	SATCOM-K1	87	W135	2, 7	DSCS-EAST PAC.	0
W078	12.2-12.7	AMEGO-2	0	W135	0.4, 1.7 & 2	GOES-6	83
W078.5	4	WESTAR VI	84	W135	2, 7	NATO IIR	0
W079	12	RAINBOW-2	87	W136	12.2-12.7	AMEGO-4	0
W079	4	WESTAR II	74	W138	12.2-12.7	CANADA-BSS	0
W081	4 & 12	ASC-2	86	W139	4	SATCOM IIR	83
W081	12.2-12.7	BRAZIL	0	W142.5	.13, .5, 1.7	GOES-4	80
W082	12.2-12.7	CANADA-BSS	0	W143	4	AURORA	82
W083	12	ABCI-1	86	W148	12.2-12.7	USA-BSS	0
W083.5	4	SATCOM IV	82	W157	12.2-12.7	USA-BSS	0
W083	4	STSC-1	88	W160	11 & 13	ESDRN-160W	0
W083.5	12.2-12.7	HAITI & DOMINICAN RP	0	W166	12.2-12.7	USA-BSS	0
W084.5	12.2-12.7	NE SOUTH AMERICA	0	W168	3.95-4.00	POTOK-3	0
W085	.8, 1.5, 12	MOBILSAT 1	87	W170	7	GALS-4	0
W085	12	USAT-1	85	W170	11	LOUTCH-P4	0
W086	12.2-12.7	PERU	0	W170	.2 & 1.5	VOLNA-7	0
W086	4	WESTAR VII	84	W171	2 & 14	TDRS-F3	84
W087	4	COMSTAR D3	78	W175	12.2-12.7	USA-BSS	0

Eutelsat I

By **Walter L. Morgan**
Consulting Editor
Communications Center of Clarksburg

The European Communications Satellites (ECS) are the first generation satellites of the European Telecommunications Satellite Organization, and are named Eutelsat I F1, F2, . . . after acceptance in orbit.

Each of the nine active ECS-1 F1 transponders is 20 watts and there are three spare transponders. The on-axis eirp of the western spot beam is approximately 48 dBW. Within this beam can be fitted Great Britain, most of France, parts of Germany and Switzerland and the Benelux countries. Two more spotbeams are available to cover other parts of the North Atlantic and Europe through the Middle East. There is an overall beam ("Eurobeam") with a 42.7 dBW on axis and 34.8 dBW at the edges.

During an eclipse five transponders can be operated on the ECS-1 F1 due to energy storage limitations. Starting with the second launch, these capabilities will be increased to nine active transponders during eclipse and two additional ones dedicated to business services.

Five spacecraft have been authorized for construction. Parts for a sixth spacecraft are being accumulated. The ECS-1 F1 spacecraft was originally considered the spare, but already all transponders have been leased for television distribution services to members of Eutelsat.

ECS joins the earlier Orbital Test Satellite (OTS-2) as a harbinger of direct broadcasting in Europe. One of the earliest operators was Satellite Television, PLC of England. This operation has recently been acquired by Rupert Murdoch.

In Europe, a direct broadcast satellite typically has an eirp of 63 dBW on axis. ECS I has a peak eirp approximately 15 to 20 dB below this level. In this way it is more like the United States domestic 14/12 GHz FSS satellites:

It will be interesting to see how the potential battle between medium and high-powered satellites for this service will evolve on the two sides of the

Atlantic. Will Eutelsat and its American cousins (such as SBS, Spacenet and Gstar) at least temporarily displace the high-powered satellites?

Voice traffic will be transmitted through the satellite using TDMA/DSI. The rated capacity is 12,000 full circuits and two television channels. A larger advanced ECS is being considered.

European business service will be provided by two additional transponders that could not be carried on ECS I F1. It was planned that these would be available on the second and later ECS satellites. The ECSs are regional satellites to connect the various countries of Europe (see map). Coordination with Intelsat was successful, however, Eutelsat reports that a re-examination is due in 1988 for the business services part.

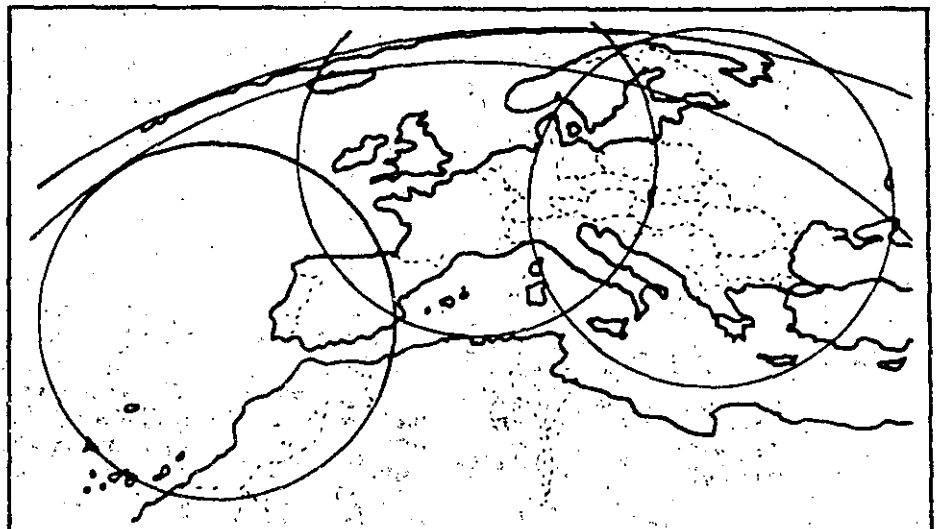
The prime contractor for these satellites is the British Aerospace Dynamics Group. Other participants include: Belgium, Denmark, France, Germany, Italy, The Netherlands, Spain, Sweden and Switzerland. Within the UK, Marconi is also involved. The distribution of contract values approximates the individual national contributions to the ECS program. The total contract value equates to about \$49 million per satellite (excluding

Ariane costs).

Derivatives from the ECS design include Marecs (see "Satellite Notebook #23"), Skynet IV (a UK military satellite), L-Sat and Unisat (see "Satellite Notebook #24"). The L-Sat has recently been renamed Olympus. □

Eutelsat Summary Table

Name of Operator	European Telecommunications Satellite Organization
Contractor	MESH Consortium (see text)
Mass at BOL	1045 to 1154 kg
Power of EOL	900 to 1000 watts
Lifetime	7 years
Launch Dates	1983 to 1985
Launch Vehicle	Ariane
Frequency Bands	
Uplink	14.0-14.5
Downlink	10.95-11.2 11.45-11.7
Business services	12.5 GHz
Polarization	Dual linear
TWTAs	Active 9 to 12 Spare 3 to 5
Eclipse	5-9 Transponders
Location	7°, 10° and 13° East
Verified	November 1983



The Future as seen in the New Domestic Satellite Filings

By Walter L. Morgan
Communications Center of Clarksburg

In April, the Federal Communications Commission of the United States announced that it was going to authorize additional domestic satellite networks. The locations for 19 of these satellites were assigned. Three of the authorizations are provisional upon meeting the FCC's financial qualifications by December 31, 1983. At least one of the provisional operators requested a delay on the basis that the FCC did not release its criteria in a timely manner.

The FCC indicated that it would accept applications until November 7, 1983 for new satellites and satellite systems to be processed in the next batch. The result is shown in the Table.

In April the number of unassigned locations stood at 2 @ 6/4 GHz, 4 @ 14/12 GHz and one at both frequencies. This totals seven, whereas the number of orbit locations requested by the applicants is 53. Obviously, there is a mismatch in supply and demand that only the FCC (and perhaps eventually the courts) can decide.

We predict that the FCC will work hard to make sure only the fully qualified applications are acted upon. Having just recently reinforced their arsenal of requirements, they will now match the responses with the rules. This may eliminate two to four applicants. Six orbit locations have been provisionally assigned (see above). The financial test may be used to eliminate one, two or all three applicants.

The Commission may thoroughly

examine the remaining new applications on the basis of the need for new or additional satellites. They may eliminate any spacecraft they consider to be excessive. System-specific market demand studies may save some of these satellites. When the FCC has completed this initial screening, it may find it has a supply of eight to ten and a demand for 24 to 32 prime orbital locations.

Six of the applicants chose to go to 16 orbit locations further to the east or west of the major belt (see December *Global Satellite Stations* chart). Still other operators may choose this course or to offer video services at 12.2-12.7 GHz (the broadcasting satellite band) instead of waiting for a 11.7-12.2 GHz authorization. If these satellites operate at low or medium power (10 to 50 watts), they may have to accept interference from the full-power (200 watt) satellites.

In some cases the FCC will not be able to reach a decision between two or more competing applications for a given orbit/frequency assignment. Comparative hearings will take place. This process can last 1 1/2 to 3 years during which there may be mergers and compromises between the various applicants. After this, the losers may try the courts.

The FCC may be tempted to go to a uniform 2* by 1987-88, which still may be too early for the vast majority of earth stations in place today.

An alternative is to use reverse frequency allocations. In this method, slots are assigned with opposing up-

link and downlink assignments: 6/4, 4/6, 6/4 GHz, etc. An earth station "sees" only one of the satellite systems. The second set is "invisible." In this way, the orbit capacity is doubled without increasing the interference, moving, or deleting the existing satellites and their earth stations. This would be timely for new systems launched in 1988 and beyond.

Several applications requested hybrid frequency assignments. American Satellite requested a satellite design that would operate at 6/4, 14/12 and 30/18 GHz. As predicted, 101 West (the only unassigned hybrid location) received more applications (7) than any other. This is also the most desirable BSS location for the Eastern U.S. The first Western "Orbital Antenna Farm" (see *Satellite Communications*, April, 1978) may be located here.

Among the important trends now evident are the solid interest of American industry in satellite communications. The filings of Federal Express, Digital Telesat (a DTS/DEMS operator), Equatorial (spread spectrum services) are all examples of organizations that may consume most or all of the capacity themselves.

One of the more unusual applications is from Systematics General. It proposes to act as a non-common carrier providing transatlantic international service. It would have the U.S. government launch and hold all risk to several TDRS satellites, to acquire the 6/4 GHz capacity (ex-Advanced Westar) and then lease it back to the government.

DOMESTIC FIXED SATELLITE APPLICATIONS

Applicant	Status	Satellite Locations		Applicant	New	Add	Rev	Prov	New	Add	Rev	Prov	New	Add	Rev	Prov	
		Authorized Now	New Request														
6/4 GHz only satellites																	
Alascom, Inc.	New	1	2	Aurora	0	2	0	0	2	Gstar A-3	0	2	0	0	0	0	0
AT&T Communications	Add	4	1	Telstar 304	0	1	0	0	3	Galaxy-K	0	2	0	0	0	0	0
Cablesat General	Rev	0	2		0	2	0	0	2		0	2	0	0	0	0	0
Digital Telesat	New	0	1		0	1	0	0	2	cluster	0	2	0	0	0	0	0
Equatorial Comm.	New	0	2		0	2	0	0	2		0	2	0	0	0	0	0
Hughes Galaxy	Add	3	1	Galaxy IV	0	1	0	0	3	Salcom-K	0	2	0	0	0	0	0
National Exchange	New	0	2	cluster	0	2	0	0	5	SBS-6	0	2	0	0	0	0	0
RCA Americom	Add	5	3	Salcom*	0	3	0	0	2	USAT-3&4	0	2	0	0	0	0	0
Systematics General	New	0	2	TDRS-East	0	2	0	0	0		0	0	0	0	0	0	0
Western Union	Add	4	3	Westar	0	3	0	0	0		0	0	0	0	0	0	0
14/12 GHz only satellites																	
Adv Bus. Comm. Inc.	Prov	2	0		0	0	0	0	0		0	0	0	0	0	0	0
Comsat General Corp	New	0	3	Comstar/SBS	0	3	0	0	0		0	0	0	0	0	0	0
Digital Telesat	New	0	2		0	2	0	0	0		0	0	0	0	0	0	0
Hybrid satellites (6 14/4, 12 unless noted)																	
American Satellite	New	2	2	also 30/18 GHz	0	2	0	0	0		0	0	0	0	0	0	0
Columbia Comm Corp.	New	0	2		0	2	0	0	0		0	0	0	0	0	0	0
Ford Aerospace	Rev	0	3		0	3	0	0	0		0	0	0	0	0	0	0
GTE Spacenet	Add	3	1	Spacenet IV	0	3	0	0	0		0	0	0	0	0	0	0
RCA Americom	New	0	3		0	3	0	0	0		0	0	0	0	0	0	0
Totals					38				53	= 91							

*RCA requested 3 new satellites at 6/4 and 3 at 14/12 or 3 hybrids.

RCA Satcom 14/12 GHz Satellites

By Walter L. Morgan
 Consulting Editor
 Communications Center of Clarksburg

RCA American Communications, Inc. (RCA Americom) has been authorized three locations for satellites to operate in the 14.0 to 14.5 GHz/11.7 to 12.2 GHz bands. These are designated K1 to K3. K4 is a ground spare. In November 1983, they applied for three additional Ku-band satellites (K5 to K7) to operate at these frequencies. Each of the new satellites would either be dedicated Ku-band or part of a hybrid Ku-band and C-band (H1 to H3). If the dedicated 14/12 GHz satellites are used, RCA plans to co-locate a dedicated 6/4 GHz satellite at each of the three requested locations. This Notebook deals only with the all-14/12 GHz satellites. The Table compares the two all-14/12 GHz satellite designs. As indicated last month, the fate of the newly requested satellites is unclear.

Following RCA's normal practice, these will be three axis spin-stabilized satellites. All of the satellites carry 16 transponders in the medium power range.

In its original application (in April 1982), RCA planned to operate 20- and 30-watt transponders. This was later increased to 50 watts. Now both series have 50 watt transponders. The transponders have been designed to compensate for 14 GHz fades. There are step attenuators and the earth stations use uplink power control. Each channel also has a driver limiter amplifier that may be switched in or out by ground command. A dynamic range of 25 dB is provided with 16 dB coming from the limiter.

The eastern coverage pattern of the newest satellites include Texas. This permits keeping the EST and CST time zones together.

Two contiguous band output multiplexers are used. Each TWTA has access to both output multiplexers through a variable power divider. Pow-

PURE Ku BAND RCA SATCOMS

Name (Satcom -)	K1 to K3	K5 to K7
Original application	April 1982	November 1983
Status	Approved	Requested
Orbit Locations	77, 87 & 126*	61, 63 & 65 West
Launcher	STS/PAM-D	STS/PAM-DII
Transponders	16	16
Redundancy	5 for 4	11 for 8
Bandwidth	54	54 MHz
RF Power Output	50	50 watts
Total RF Power	800	800 watts
Nominal eirp	44-50	44-50 dBW
Launches	1985, 86, 87	1988, 89, 91
Mass (BOL)	664	1017 kg
Power (BOL)	1395	2440 watts
Lifetime	10	10 years

Verification Date: December 1983

*RCA has requested a swap of 67° for 126°W

er may be sent to either the east, west or both output multiplexers to form a conus beam. There is another pair of multiplexers for the opposite polarization. The nominal insertion loss of an output multiplexer is 1.35 dB. An extensive reliability analysis has been conducted which indicates that out of 165 possible TWTA failure combinations, only three modes result in loss of operating capacity.

RCA states that it plans to invest \$306 million in the first series and \$439 million in the second.

The Satcom series growth may also be measured in terms of power. The solar array output of K 5-7 is approximately twice that of the 6/4 GHz Satcom's. The solar array area even with improved solar cells is 157 versus the 75 square feet used in Satcom I.

The travelling wave tubes are concentrated on two south-facing panels. Two north panels carry the momentum wheels, telemetry, batteries, beacons and other equipment. A central cylinder surrounds the apogee kick motor and carries many of the spacecraft loads especially during launch. Four hydrazine tanks are hung off its struc-

ture. The antenna farm, complete with the feeds and the reflectors form still another surface.

K1 to K4 have four spare transponders whereas K5 to K7 will have six. All satellites carry four receivers of which only two are required to meet the mission objectives.

The authorized satellite covers conus, Alaska/Hawaii, eastern conus and western conus. Due to the eastern location, coverage of Alaska/Hawaii may be better served using 6/4 GHz Satcoms.

The satellite services include: Teleconferencing; Distribution to LPTV stations; Voice; Data; TV to hotels, motels, and multi-unit dwellings; Digital termination services; and Educational television.

The voice capacity of a 36 MHz transponder has grown from the initial 792 FDM/FM voice grade circuits to today's 2892 in a single 36 MHz transponder. Newer techniques employing single sideband/AM has increased this number to 7000. The wider bandwidth of the new satellites (54 versus 36 MHz) should expand these numbers even further.

M-SAT

By **Walter L. Morgan**
 Consulting Editor
 Communications Center of Clarksburg

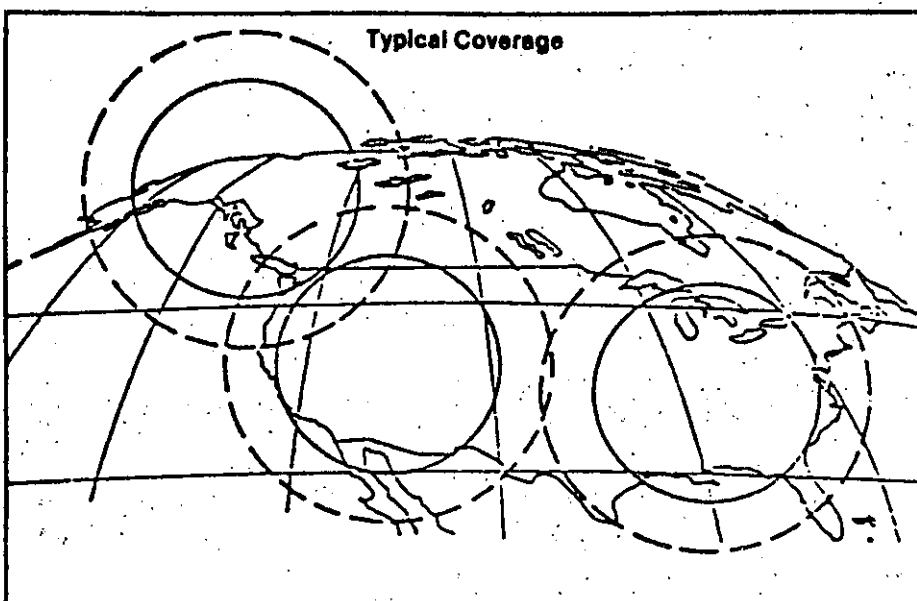
M-SAT is an acronym for a mobile satellite concept that has been under development by NASA and the Canadian Department of Communications. It would provide communications for people on the move, by foot, by ship or land vehicle. Its principle users might be in the wide open spaces of Canada and the United States.

In some of these cases the term "Mobile" may be an exaggeration and perhaps the term personal satellite service would be much more appropriate as it would encompass both the moving and the non-moving applications and serve the public at the individual level rather than on a community or company basis. A personal satellite of this type might also be used to restore telecommunications in the case of an emergency (flood, damage to the telephone company facilities, earthquakes, volcanic eruptions, etc.).

In 1979, the World Administrative Radio Conference (WARC-79) inserted a footnote into the table of allocations for North and South America. It indicated that the frequency band 806-890 MHz could also be allocated to mobile satellites (except aeronautical mobile satellites) on a primary basis. The service was only for use within national boundaries.

NASA has requested permission from the FCC to use two frequency bands (821-825 MHz for the uplink and 866-870 MHz for the downlink) and that 845-851 and 890-896 MHz be reserved for future growth. These frequencies correspond to former television channels 72, 76 and 80. They also are within the bands allocated for terrestrial mobile services.

The M-SAT is a subject of an agreement recently signed between NASA and the Canadian Government. The arrangement provides a framework for the DOC and NASA to enable mobile satellite services (on both sides of the border) to be provided by the private sector. NASA will provide a free Shuttle launch to the U.S. carrier in return for some of its capacity being made available to U.S. government agencies. The operator (yet to be selected) will make further agreements with a Canadian counterpart (probably Telesat Canada).



Mobile Satellite Concept

Operator	To be selected	Mobile Terminal
Location	106.5° West	End user
Launcher	Shuttle	US and Canada
Launch date	1987 or 1988	—
Lifetime	7 years	—
Frequencies		
Uplink	821-825 MHz & 14 GHz	821-825 MHz
Downlink	866-870 MHz & 12 GHz	866-870 MHz
Antenna Size	9 m diameter	Drooping dipole
Antenna Gain	35 dBi	+ 4 dBi
Beams	5 (+ 1 @ 14/12 GHz)	1
Modulation @ UHF	QPSK*, AM-SSB* or NBFM (same)	
Bandwidth	Up to 4 MHz @ UHF	5-27 kHz
Solid State	30 watts	2-10 watts
Transmitter		
eirp Per Channel	37-38 dBW	6-13 dBW
Figure Of Merit @ UHF	-1 dBi/K	-24.1 dBi/K
Receive Sensitivity	-100 dBm	-120 to -126 dBm
	*5 kHz vs 27 kHz for NBFM	
	Verified — January 1984	

Three commercial applications have been submitted to the FCC for consideration. These are (in alphabetical order) Geostar, Inc., (which has a position locating and message distribution capability), Mobile Satellite Corporation and Skylink, Inc.

The actual design of the satellite would depend upon which commercial entity was chosen, the demands of the two governments, the perception of the requirements of an untested marketplace, etc.

The key to these satellites and their mobile stations is in the antenna systems. Both require advances to dramatically increase the number of circuits in the systems. The mobile ter-

minals may use a drooping dipole (+ 4 dBi), quadrafile or planar arrays (80 x 80 cm with - 12 dBi).

The bandwidth is dependent on the modulation. QPSK and SSB-AM require 5 kHz vs 27 kHz for narrowband FM.

Various models of the mobile satellite have been constructed on paper. These involve the use of 5 to 69 spot beams covering the United States and Canada.

The anticipated demands for these terminals fall between 160,000 and over one million mobile units in operation by 1990 and by the turn of the century somewhere between 300,000 and three million would be placed in service. □

Tele-X and Nordsat

By Walter L. Morgan
Communications Center of Clarksburg

The Tele-X satellite is derived from the TV-SAT/TDF-1 satellites. It is a precursor for the Nordsat series of satellites. Tele-X, produced by the Eurosatellite GmbH Consortium will mark the first export outside of the countries of the owners. The Consortium is composed of Aerospatiale, prime contractor (France); Thomson CSF (France); MBB (West Germany); AEG (West Germany) and ETCA (Belgium). The Swedish companies LM Ericsson and SAAB-Space are responsible for essential parts of the development and the production. The Tele-X contract has been let by the Swedish Space Corporation of Stockholm (a state-run corporation).

Earlier concepts of this satellite included the use of 30/20 GHz experimental beacons and land mobile (Trucksat) payloads. These were dropped and at present the Tele-X consists of two high-powered television trans-

ponders at 12 GHz and two high-powered transponders for data (one wide-band and one narrow-band). While the first two are intended for direct broadcasting, the others are for business and video communications (meaning for teleconferencing or broadcasting network feeds). The data/video earth stations will be small and inexpensive.

Nordsat is scheduled to be launched about two years after Tele-X and eventually there will be two or three Nordsat satellites. These will have three or four high-powered television transponders for Eastern Scandinavia plus one to Iceland. There may also be capacity for other telecommunication services.

The satellites will be located at five degrees East longitude, thereby providing a high elevation angle in these northern countries. The principle earth stations will be provided by L.M. Ericsson (Sweden) and Elektrisk Bureau

(Norway). The origin of the satellite components is shown in the figure.

The cost of the Tele-X satellite is around \$88 million. The total Tele-X system cost is expected to be around \$200 million including the launching, earth stations and the control center. Sweden will assume more than 80 percent of these costs, Norway 15 percent and Finland. A different distribution of costs will be used for the Nordsat.

The Ariane is anticipated to launch Tele-X in early 1987.

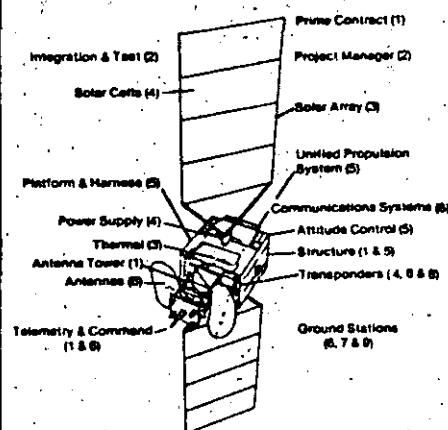
An organization initially owned by the Swedish and Norwegian Telecommunications Administrations has been formed in order to promote the interests of the Nordic Telecommunications Administrations in joint satellite projects. The organization is called Nordic Telecommunications Satellite Organization (Notelsat) and its first task will be to operate Tele-X.

Tele-X and Nordsat Summary Table

Name of Satellite(s) Name of Operator	Tele-X Swedish Space Corp.	Nordsat or Tele-Nord	
Contractor	Eurosatellite GmbH		
Number of satellites	1	2 to 3	
Launch mass	2185 (4807)	—	kg (lbm)
Mass at BOL	1300 (2860)	—	kg (lbm)
Power at EOL	3000	—	Watts
Height	5	—	meters
Wingspan	19	—	meters
Stabilization	3-axis	3-axis	
Lifetime	5 to 7	—	years
Launch dates	Late 1986	c. 1988	
Launch Vehicle	Ariane		
Services (transponders)			
Direct to home video (Scandinavia)	2	3 to 4	
(Iceland/Greenland)	0	1 to 2	
Radio	0	11 Channels	
Data (SCPC)	1		
Business*	1		
Frequency bands (uplinks)	17	17	GHz
(downlinks)	12	12	GHz
Polarization	(WARC-77)		
Location	5		East

*Including video not intended for direct reception in the home.
Verification Date: February, 1984

Sources of Tele-X Equipment



PARTICIPANTS:

- 1 — Saab Scania
- 2 — Aerospatiale (for Eurosatellite)
- 3 — Aerospatiale
- 4 — AEG Telefunken
- 5 — MBB
- 6 — L.M. Ericsson
- 7 — Elektrisk Bureau
- 8 — Thomson-CSF
- 9 — Swedish Space Corp.

Telecom-1

By Walter L. Morgan
 Consulting Editor
 Communications Center of Clarksburg

France's Direction Generale des Telecommunications (part of the Ministry for Post and Telecommunications) is constructing three communications satellites — Telecom 1A through 1C. These are multifrequency/multipurpose satellites.

Coverage

The Telecom series will serve metropolitan France, part of Europe and the French overseas departments and territories from the Caribbean Sea to the Indian Ocean. (See map for coverage areas)

Bands and Uses

The satellite operates in three bands. (See Table 1)

The 6/4 GHz transponders are intended for PTT service between Europe and the French Overseas Departments. Each 4 GHz transponder has the capacity of 1,000 telephone circuits or one television program.

The odd-numbered 6/4 GHz transponders are 36 GHz wide, whereas the other two are 120 GHz each. Transponder 2 serves French Guyana and the Caribbean using a spot beam downlink. The other transponders provide a pecan-shaped, half-global downlink service. The 6 GHz uplinks for all beams are global.

The military portion of the satellite operates in two 36 MHz transponders between the frequencies of 7.98-8.02 and 7.255-7.295 GHz. The satellite coverage is global in both directions. This equipment will use code division multiple access (CDMA).

The 12 GHz Satellite Multipoint Service (SMS) has been likened to a French version of SBS as it is intended to provide private intracompany links. It may also be used with transportable earth stations for emergency links, remote pickup of sporting events, etc. The charges for private 14/12 GHz services are shown in Table 2.

Matra is the prime contractor for Telecom-1. Subcontractors include Thomson-CSF, SNIAS and Ford Aerospace.

The 8.5 watt, 4 GHz tubes comes from

Hughes. The 20 watt, 12 GHz tubes are similar to ECS. The TWT is provided by Thomson-CSF and the electric power

conditioner is made by Ford. In 1982, the estimated cost of the three satellite system was \$264 million. The Ariane

Table 1
 TELECOM-1

Locations:	352, 355 and 4 E
dimensions —	
length (deployed)	15.98 meters
width	2.18 meters
height	2.96 meters
Beginning of Life mass:	
Transfer orbit:	1170 kg
Geostationary orbit	650 kg
Lifetime:	7 years
End of life power	1100 watts

Transponders			
6/4 GHz	2 at	36 MHz	at 8.5W
	2 at	120 MHz	at 8.5W
8/7 GHz	2 at	36 MHz	at 20W
	6 at	120 MHz	at 20W
14/12 GHz airp:	4 GHz	Caribbean	34.6 dBW
		France	28.5 dBW
8 GHz		Semi-global	26.5 dBW
	12 GHz	Global	27.2 dBW
		France	47 dBW
		Neighboring countries	44 dBW

Verified: 1984

Table 2
 Dedicated Links
 14/12 GHz

Annual Subscription Fees
 (per full channel)

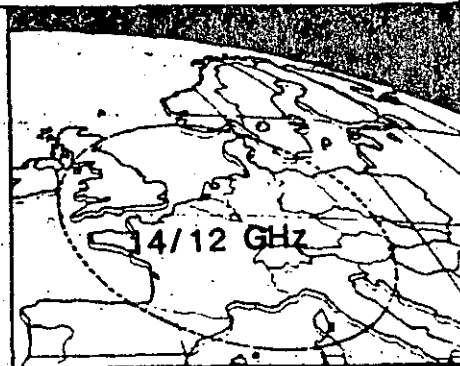
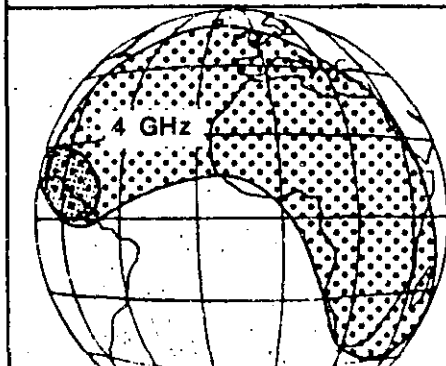
64 kb/s	\$8,000
2.048 Mb/s	\$20,400

Time Charges
 (per half circuit minute)

64 kb/s (peak time)	\$.40
(night time)	\$.133

Reception Charges

One to two sites	\$13,600
Three to six sites	\$20,400
Additional sites	\$3,400



European coverage areas of the Telecom-series of satellites.

launches are estimated at \$26 million each.

12 GHz TDMA

The 12 GHz TDMA service operates at 12 x 2.048 Mb/s (or 24.576 Mb/s). The frame time is 20 ms. Six transponders of 36 MHz each are carried in the bands between 14.0-14.25 and 12.50-12.75 GHz. The modulation is PSK with differential coding using either PPSK or QPSK.

The service offerings run between 2.4 kb/s and 2.048 mb/s. Among the services envisioned are teleconferencing, data transfer (to 2 mbs), PBX interconnection and video distribution for corporate needs.

An incoming 64 kb/s data or digitized voice channel is increased to 72 kb/s by the time the various coding, signaling and overhead functions are added. The forward error correcting code system operates at rate 4/5 to provide a bit error rate of less than 10^{-10} for 99 percent of the time.

Five of the six 12 GHz transponders will be for TDMA. One is set aside for video teleconferencing. The interface between the earth stations and the terrestrial network will be accomplished using CCITT no.7 ISDN interfaces x.21 and v.35, etc. When the system is com-

pleted approximately 60 earth stations will be able to access each transponder.

The TDMA system is orchestrated from a common master earth station. This station transmits the timing reference for burst synchronization and allocates a portion of the total time to each station. The master station, called the System Management Center (SMC), is located in eastern France at Mulhouse. The SMC monitors the performance of each station, its traffic, the status of its equipment and responds to any alarms from the unattended earth stations. It also accepts reservation requests from the remote stations and assigns the proper amount of transponder resource.

Earth Stations

The 6/4 GHz earth stations envision the use of the Intelsat standard D earth station with a diameter of approximately 11.8 meters. The 14/12 GHz intra-company earth stations will have typical antenna diameters of 3.5, 4.5 and up to 8 meters. Receive-only terminals for direct broadcasting in auditoriums, etc. will use 1.8 to 2.3 meter antennas. The terminals for business service are being produced by Telspace (a TH-CSF/CIT joint venture); the TVRO terminals by Matra, M/A-Com and Telspace.

The transmit/receive antennas will be in the 3.5 to 8 meter range. Typical earth stations will have an eirp of 69.5 dBW using a transmitter of 150 watts.

Launch

The MAGE-2 apogee motor will be used. Its mass is 465kg (1022.91bm). Telecom 1A will be co-launched with ECS-2 (Eutelstat 1-2) in mid 1984. The Telecom 1B satellite may be co-launched with GStar-1B or with Spacenet-3 in early 1985.

Intelsat

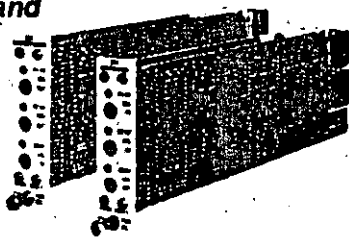
In September 1982, Intelsat granted Thompson 1-A a five-year coordination after which time it must prepare a new submission to Intelsat for coordination under Article XIV (d). This is the economic impact section.

In addition to potential competition in the marketplace, Intelsat was concerned about future interference from a pre-existing series of Telecom satellites into the newly proposed Intelsat Business Services which may eventually use these frequencies (reference: Intelsat Document BG-52-46, item 3.0).

Further history of this program is contained in the June 1982 issue of this magazine.

New! ESC Multiplexer and Demultiplexer

Provides P1(4-8 kHz) and P2(8-12 kHz) ESC voice channels required in the INTELSAT FDM and CFDM systems for maintenance and supervision.



- Multiplexer accepts two voice channels, each with a 300-3400 Hz bandwidth and multiplexes them to output spectrum of 4-8 kHz (P1) and 8-12 (P2). Both channels are then combined to provide one composite 4-12 kHz spectrum for injection into the transmit baseband.
- Demultiplexer accepts composite 4-12 kHz spectrum from received baseband,
- separates the 4-8 kHz and 8-12 kHz channels, then demultiplexes each to provide two voice channels with 300-3400 Hz bandwidth.
- Compact modular construction.
- Provides space, power and cost reductions to ECS equipment.
- High reliability, low power consumption.



ELECTRONICS DIVISION
POTOMAC MARINE & AVIATION, INC.
3508 Lee Highway • Arlington, Virginia 22207 U.S.A.
703 525-2626 Telex: 440052 PMAI USA

STARS

Satellite Transmission And Reception Specialists



Complete transportable, state-of-the-art equipment and services for satellite communications including three, fully redundant, 5-meter uplink units. We supply all uplink and downlink equipment needs, from a single reception unit to a complete transmission and reception network with signal encryption.

713/988-0306
713/988-7711

9000 Southwest Freeway
Suite 314
Houston, Texas 77074

Insat-1

By *Walter L. Morgan*
Consulting Editor
Communications Center of Clarksburg

The Indian National Satellite System (Insat) uses triple hybrid satellites consisting of communications, broadcasting and meteorological missions. This is a remarkable achievement considering the individual mission complexities and especially as they are contained on a medium class satellite.

The Insat system will bring more benefits to more people (over six hundred million) than any other single domestic system. It provides warnings of typhoons and monsoons, basic telecommunications, educational TV and national unity.

The Insat-1 program is a direct result of prior experience with other satellites.

The Satellite Instructional Television Experiment (SITE) used ATS-6 to provide a demonstration of the value of satellite communications to India. This was followed by the Satellite Telecommunications Experiment Project (STEP) using the Franco-German Symphonie Satellite. After STEP ended in 1979, India leased a quarter transponder from INTELSAT. In 1981, India launched its own experimental satellite, the Apple (Ariane Passenger Payload Experiment). The Apple was constructed entirely in India.

The original Insat-1 contract with Ford Aerospace & Communications is dated July 19, 1978.

The Insat program is managed by the Indian Department of Space under the guidance of the government of India's Insat Coordination Committee.

Communications

The telecommunications functions include the normal telephone and television point-to-point services.

Radio program distribution is one of Insat-1's missions. A typical radio receive-only station will be capable of handling five audio channels. In addition to the normal entertainment functions, there are channels for standard time and frequency signals, disaster weather signals, etc.

The direct television broadcasting service is being used for educational and agricultural programs to village receivers in rural areas.

Over 100 data collection platforms (DCPs) will be placed on both land and sea areas for relay through Insat-1 to the Meteorological Data Utilization Center at New Delhi.

Frequencies

The frequency plan is unusual. The uplink consists of 14 36 MHz channels with a gap for the telecommand frequencies. The uplink ranges between 5.855 and 6.425 GHz.

As in the case of Intelsat VI, we are beginning to see the gradual spreading of these bands beyond the normal 5.925-6.425 GHz range. These new frequencies have been authorized for service by the International Telecommunications Union at the 1979 WARC meeting.

There also is an uplink with a nominal frequency of 402.75 MHz from meteorological and hydrographical data collection platforms.

The downlinks consist of 12 transponders in the fixed satellite service (3.71-4.2 GHz) with a gap between the eighth and ninth transponder for two telemetry carriers, radiometric data (4.03455 GHz), and the DCP downlink (4.038 GHz).

The television broadcasting downlink has two channels centered at 2.575 and 2.615 GHz. Radio program distribution also uses these frequencies.

A village television receive-only station has a typical antenna diameter of 3.6 meters and system noise temperature of 610 Kelvin. The G/T is +8.2 dB/K.

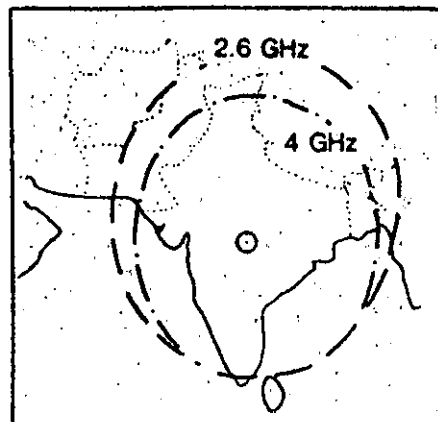
Insat will be used to distribute two television programs to the existing TV transmitters (100 Watts).

Weather

The meteorological radiometer takes 30 minutes to scan the entire earth with 4,000 picture elements. The ground resolution of each picture element in the visible spectrum is 2.75x2.75 kilometers. The infrared resolution is 11x11 kilometers. There is also provision for scanning less than the full earth in both east-west and north-south directions.

The Spacecraft

The spacecraft has an unusual configuration (see Figure). The reason there is only one solar panel is that the scanning radiometer detectors must operate at a cold temperature. Radiation cooling (using the near-absolute zero of deep space) provides the low temperature. If the sun, earth or moon were to look down the cooling cone, the detector temperature would increase resulting in either degraded performance or detector destruction. The geometry dictates that the cooling cone looks either north or south. On the south end of the spacecraft



is the solar array with solar cells that would emit and reflect the heat from the sun into any cooling cone. To place a second array on the north side would not work because the cooler looks toward the north.

A single solar array has a center of solar pressure different than the center of gravity. The sun will attempt to turn the spacecraft over the same way the wind turns a windmill. To avoid this problem, a counterbalancing solar sail is used. The five-section solar array is closer to the body than a typical body stabilized satellite design. This provides a short lever arm to the sun. A 3.35-meter high solar sail cap is located at the end of a long (12.19 meter or 40 foot) boom to provide a compensating lever arm. There is little likelihood of it being seen by the radiation cooler. The base of the cap has a diameter of only 92 cm.

Without the solar sail, the spacecraft is inherently solar pressure unbalanced. Fuel must be used to remove the attitude errors due to the unbalance torque. Magnetic torque coils are used for fine controls.

During the transfer orbit several deployments must take place. The rectangular antenna and two of the five sections that comprise the solar array are released. These array portions extend at right angles from the south and anti-earth sides of the spacecraft. After the third firing of the 490 Newton apogee motor the remaining sections are released and then the yoke is released. It was during the yoke release that trouble was encountered and later resolved on Insat-1B.

Insat-1A

Insat-1A was launched on April 10, 1982 on a Delta 3910 using a PAM. The satellite was deactivated September 4 of the same year.

There were difficulties in deploying one of the antenna reflectors and the counter-

balancing solar sail never did get deployed. The solar sail problem eventually led to the demise of the satellite.

The sequence of Insat-IA's final minutes may have been like this:

(a) It was September and the eclipse season. Insat-IA was about to enter the shadow of the earth. As usual at this time of the year, the sun would be waiting for the satellite when it left the shadow. The sun was near the equator, thus the first horizon sensor (it looks for the edge of the earth in the equatorial region) was turned off to prevent the sun from capturing the satellite's attitude control. The status of the fuel and propellant valves were undetermined.

(b) There had been a yaw axis error buildup (due to the uncompensated solar torque from the unbalanced solar array).

(c) The satellite entered the shadow of the earth.

(d) Insat-IA exited the shadow of the earth.

(e) The second horizon sensor saw the full moon (due to the yaw error which had mispointed the sensor).

(f) The second horizon sensor deactivated itself (now neither horizon sensor was operational).

(g) With no information on where the earth is located the attitude control was automatically switched to the safe mode.

(h) The 6 GHz (India coverage) communications antenna moves off India.

(i) The 4 GHz telemetry link, which used the India coverage antenna, was lost intermittently due to antenna mispointing.

(j) A safing command sequence was sent to the satellite but not received. Among these commands was an attempt to switch telemetry to the omnidirectional TT&C antenna.

(k) The attitude and orbit control produced "glitches" in the attempt to find the earth. These caused unintentional firing of thrusters thus making the attitude errors greater.

(l) The satellite attempted to correct the attitude errors and consumed all available propellant.

On January 27, 1984 NORAD reported the satellite was at 47.6 West and drifting westward at 0.870 degrees per day.

A thorough review was held with the Department of Space and Ford Aerospace. Solutions to these problems were

introduced into Insat-IB and IC. These included an automatic switch to omnidirectional telemetry upon loss of earth pointing, modifications to the propellant isolation valve circuitry, solar sail deployment, antenna deployment and the ground control software.

Replacement capacity was obtained on two INTELSAT and one Stationar-6 transponders. The Stationar-6 transponder was used for TV distribution.

Conclusion

India's Prime Minister Indira Gandhi stated, "Insat is a national system and endeavor. It indicates that developing countries can face the risks of innovation in the application of advanced technology to solve earth-bound problems. They

need not always follow the well-trodden pathways which are thought to be risk-free."

Satellite

Names:

Owner:

Launches:

Launcher:

Locations:

Transponders:

Nominal

Lifetime:

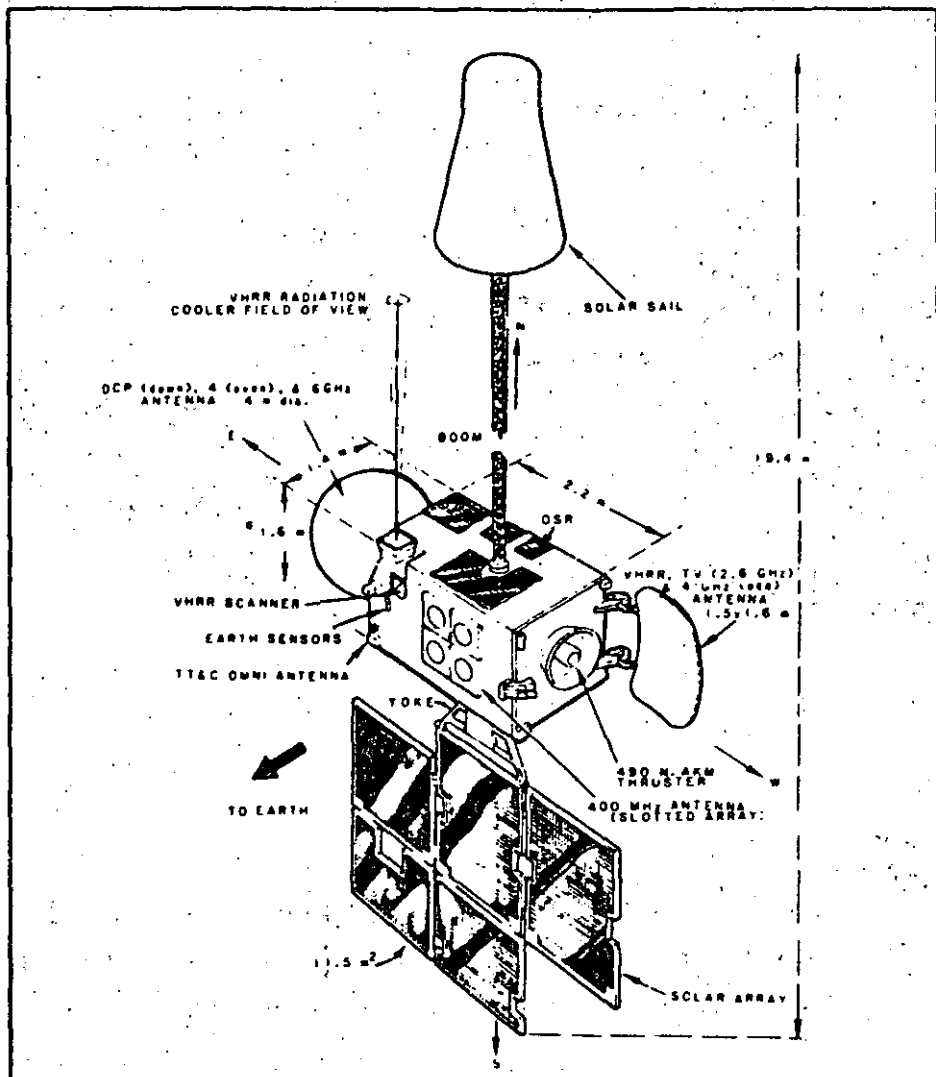
TT&C Center:

Verified:

Insat-IA, IB & IC
Government of India
1982, 1983, & 1986
Delta, STS & STS
(drifting) 74°E &
94°E
12 of 36 MHz each
at 4 GHz, 2 of 36
MHz each at 2.6
GHz (also DCP &
meteorological)

7 years
Hassan, India
May 15, 1984

858



AD INDEX			
Compucon	52	Netcom	5
Comsearch	3	Potomac Marine	46, 47
Comtech Data	55	TVRS (STARS)	46
GTE-ISC	2	Telewire	32
Harris Corp.	56	Video Net	54
Microdyne	53	Videostar Connection	6
Midwest Corp.	7		

Insat-Part 2

By Walter L. Morgan
Consultant
Communications Center of Clarksburg

This is a continuation of the Insat-I system story. It also includes data just received from India, showing the current status of the Insat satellite system.

After the loss of Insat-IA through a chain of unlikely events (see last month), modifications were made to assure the success of the subsequent satellites.

Insat-IB

The Insat-IB was launched on Aug. 31, 1983 using Shuttle STS-8.

When it became time to deploy the entire solar array for geostationary orbit use, one of the two control rods that held the yoke did not release. The satellite was rotated 18° and thrusters were fired. This was repeated on a second day after the sun's rays had a chance to heat soak the control rod/yoke area and was unsuccessful. Subsequently, after additional heating, the yoke and the array popped out on Sept. 10th.

At the end of these maneuvers there was at least seven years of fuel remaining on Insat-IB. The Insat-I system achieved its initial operational status on Oct. 15, 1983. The end of life is projected as the first quarter of 1991.

Following the initial six months of operation, Ford Aerospace was awarded 100 percent of the orbital incentives on the Insat-IB performance. All anticipated services are being provided. It is located 74° East Longitude.

Insat-IC

The loss of Insat-IA resulted in an insurance claim of \$65.5 million. This is being used, in part, to pay for Insat-IC and the Shuttle launch.

A \$58 million contract was signed on June 27, 1983 with Ford Aerospace and Communications Corp. for the Insat-IC satellite. It will be launched on a 1986 Shuttle.

The Insat I System Status (mid-June 1984)

Earth Stations

The Insat-I network now links 39 of India's 48 TV transmitters. India is constructing a network of 125 new low-power TV stations and 15 more high-power TV stations. These stations will be on the air by March 1985 and linked by Insat. The broadcast TVROs have a 6.1 meter antenna with a G/T of 24.6 dBI/K. Five TV uplinks (including a remote village) were used when the Insat-I system was dedicated to the service of India on Feb. 11, 1984.

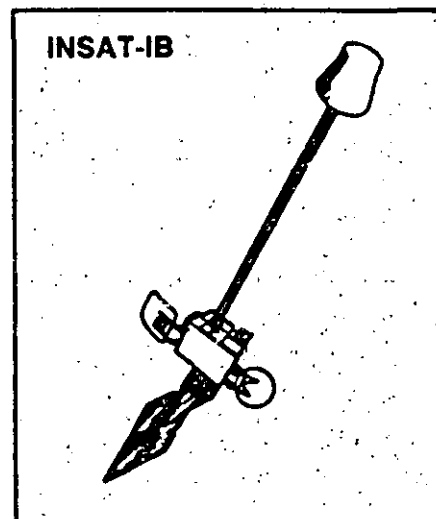
There are now 800 community reception TVROs with 2,000 anticipated by July 1994.

Twelve data collection platforms (DCPs) were in operation by mid-June 1984 and about four are being added each month.

The Scanning Radiometer

A frame takes 28 minutes and contains 8,000 x 1,137 picture elements for the visible channel. The infrared frame has 4,000 x 1,137 picture elements. The scanning is always in the north/south direction.

The solar sail may be seen by the radiation cooler, but it does not degrade the performance of the radiometers.



Insat-II

The first launch of an Insat-II test satellite is scheduled for late 1988 or early 1989. This will be followed by the operational Insat II system. These satellites will be built in India. The definition of this program is under way and the project start is expected sometime in the second half of 1984.

Management

The management of the overall Insat system implementation and operation rests with the Secretaries Insat Coordination Committee (ICC) of the Government of India. The ICC represents many different ministries (such as communications, civil aviation and information and broadcasting).

The Secretariat in the Department of Space of the Government of India is charged with the implementation and operation of the space segment.

Conclusion

"Insat is a national system and endeavor. It indicates that developing countries can face the risks of innovation in the application of advanced technology to solve earth-bound problems. They need not always follow the well trodden pathways which are thought to be risk free," stated Prime Minister Mrs. Indira Gandhi.

Satellite Names:	Insat-IA, IB & IC*
Owner:	Government of India
Launches:	1982, 1983, & 1986*
Launcher:	Delta, STS & STS*
Locations:	(drifting), 74°E & 94°*
Transponders:	12 of 36 MHz each at 4 GHz, 2 of 36 MHz each at 2.6 GHz (also DCP & meteorological).

Nominal Lifetime:	7 years
TT&C Center:	Hassan, India
Verified:	June 12, 1984

* Respectively

Brazil's SBTS A1 & A2

By Walter L. Morgan
Communications Center of Clarksburg

SBTs stands for the "Sistema Brasileiro de Telecomunicacoes por Satellite." This system is being constructed by Spar Aerospace Ltd. (Canada) in conjunction with Hughes Aircraft Company (USA), Telesat Canada and SED Systems Limited (Canada). In shortened form, this system is referred to as Brasilsat.

The system is being constructed for the Empresa Brasileira de Telecomunicacoes (EMBRATEL), which is a subsidiary of Telebras which in turn is controlled by the Brazilian Communications Ministry.

Demonstrations of satellite communications capabilities were provided to Brazil in 1973 using a transportable (2.4m) earth station and to the hospital ship S.S. Hope when it was anchored at Maceio in 1973.

Brazil currently leases seven transponders from Intelsat for domestic services and uses more than 20 earth stations.

The SBTS spacecraft resembles the Anik D series. The antenna pattern, of course, is substantially different. The on-axis eirp is similar to a domestic U.S. or Canadian satellite even though the area covered is larger.

These satellites will provide domestic communications to Brazil, which has a population of 115,400,000 and a land area of 3,286,470 sq. mi.; it is the fourth largest country in the world. Major cities within Brazil are separated by many miles of jungle and an extensive river system that make construction of conventional terrestrial systems difficult and expensive.

In addition to commercial voice grade

long distance telephony, data services and television distribution, SBTS will provide thin route communications to remote areas of the nation presently without adequate service. This in turn will permit the development of Brazil's vast resources, which may ultimately resolve its current foreign trade and economic difficulties.

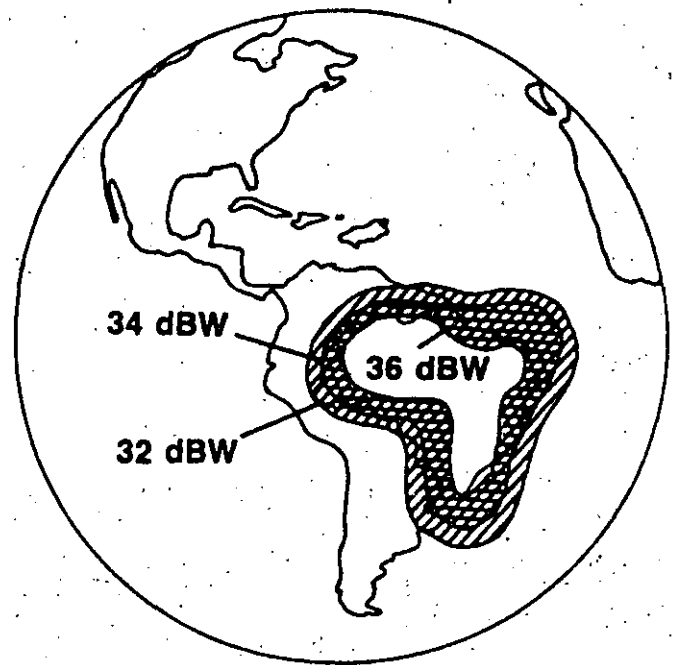
Single channel per carrier (SCPC) two-way earth stations may use antennas as small as 5 meters, a system noise temperature of 150°K and uplink eirps of 35 to 44 dBW. Television receive-only service will be possible using 3-meter earth stations. Television transmissions may use a 7.5-meter earth station antenna, thereby permitting the eventual growth of statewide television networks.

SBTS A1 will be launched in February 1985 on an Ariane 3. The second flight is scheduled for July or August 1985. There is also a reservation for a July 1988 launch on Shuttle 81-P for SBTS A2.

Included in the \$131.1 million contract are two spacecraft and three telemetry tracking and command stations (provided by SED).

Spar Aerospace will provide the communications equipment for the satellite, satellite system integration, 17 months of spacecraft operations training for 35 EMBRATEL personnel and maintenance of the spacecraft in orbit for six months.

Hughes' share of the contract is \$42.5 million (32 percent). Hughes will be providing the satellite structures, the electrical power subsystem, the attitude control, reaction control and thermal control subsystems, as well as the apogee kick motor and antenna reflectors.



The two Ariane launches will cost \$58 million, therefore, the total system expenses are approximately \$190 million.

EMBRATEL has contributed \$14.9 million in cash, the Export-Import Bank in Washington, D.C. has made a loan of \$27.6 million at 12 percent interest and there is a \$110 million loan from an eight-bank consortium led by the Royal Bank of Canada and the Bank of Nova Scotia. There will also be an offsetting balance of payments through the Canadian purchase of Brazilian exports.

Name:	SBTS A1 & A2
Launch dates:	See text
Spacecraft type:	HS-376
Mass (transfer):	1140 kg
Power (EOL):	Approx. 870W
Uplink:	5.925-6.425 GHz
Downlink:	3.7-4.2 GHz
Transponders:	
Quantity:	24
End of Life:	20
TWTAs:	30 at 9.6W
Bandwidth (each):	38 MHz
eirp:	See figure
on axis:	38 dBW
edge:	33 dBW
G/T:	+2 to -4 dBi/k
Saturation Flux Density:	-77 to -82 dBW/m ²
Design Life:	8 years
Locations:	70 and 65 West
TT&C Station:	Rio de Janeiro
Verified:	July 1984

402

TECNOLOGIA DE COMUNICACIONES POR SATELITE

RETOS PARA LA DECADA DE LOS 80's

POR D.K. SACHDEV

I N T E L S A T

JOURNAL OF SPACECRAFT AND ROCKETS

VOL. 18, No. 2, 1981

Satellite Communication Technology—Challenges for the 1980s

D.K. Sachdev
INTELSAT, Washington, D.C.

Introduction

WITH a modest beginning in the early 1960s, satellite technology has matured enough to be accepted on a worldwide basis as one of the major media for the communication networks. Communication satellites have grown rapidly in size and complexity during the 1970s and have proved their worth through steadily decreasing unit circuit cost as well as exceptional reliability.^{1,2} However satellite technology development is nowhere near saturation, and significant advances that will provide further reduction in cost as well as introduction of several new types of services are to be expected.³

This paper presents salient aspects of the major technological challenges ahead in this field. While international communication has been emphasized, most of the areas identified are relevant to domestic and regional satellite systems as well. The emphasis throughout is on individual technologies, rather than on specific system or network growth, except in situations where these aspects are germane to the development of the technologies themselves.

The overall system aspects influencing the choice of technologies during the 1980s are: the need to provide increased system capacity through more efficient utilization of available bandwidth, introduction of new frequency bands, optimum utilization of newer launch vehicles, longer spacecraft life through progressive elimination of limited-life devices and subsystems, and flexibility to meet and adapt to a variety of space segment requirements.

The very first communication satellite itself represented a frequency reuse application, since the 6/4 GHz bands were simultaneously utilized by terrestrial and space systems. Once the total 500 MHz band had been utilized in the INTELSAT IV class spacecraft, the reuse of this bandwidth in the space segment itself assumed importance. Arising out of these efforts, INTELSAT IVA achieved a modest spatial reuse. The INTELSAT V spacecraft will have a combination of both spatial and polarization reuse as well as a new 14/11 GHz band. The next generation of spacecraft currently being planned is expected to have extensive reuse (up to 6-20 times depending on application) of some or all the frequency bands available today for satellite communication. Success in achieving such a high degree of frequency reuse is dependent on several system and payload technologies as well as the ability of the spacecraft bus and other support subsystems and launch vehicles to accommodate the increased capability efficiently.

Multiple reuse of frequency bands through a large number of, physically separate antenna beams requires an appreciable level of interconnectivity onboard the spacecraft. Satellite-switched-time divisional multiple access (SS-TDMA) and other digital technologies provide the necessary tools for providing this interconnectivity between different beams from a single satellite. From the point of view of an overall global network, all satellites—whether domestic, regional or international—are integrated with one or more telecommunication networks. Such networks achieve maximum flexibility when all the nodes are capable of being interconnected, generally in a hierarchical fashion. Both from the point of view of providing network flexibility and of mitigating the effects of propagation time delays in certain situations, direct links between satellites [intersatellite or cross links (ISL)] are emerging as one of the important tools for the 1980s. Beginning with a point-to-point role, the ISLs combined with onboard digital technology are expected ultimately to develop an efficient and flexible role as "switchboards in the sky" for geostationary satellites in the global communication networks.

This paper highlights some of the principal facets of the technologies enumerated above.

Intersatellite Links

In principle, a link between geostationary satellites should be the simplest and almost ideal one through an ideal propagation medium with minimum interference constraints, at least in the foreseeable future. ISLs have already been demonstrated experimentally. However, before such links are applied to public telecommunications, a number of new technologies need to be perfected and their role in global satellite networks better understood.

The starting point is choice of the frequencies. To some extent this is related to the type and volume of information sent over ISLs. Optical links are attractive for a space-to-space link.^{4,5} However, the technological development of optical ISLs will possibly receive greater impetus as the traffic requirements increase further. In the near future, practically all of the development work will be concentrated on 1 GHz bandwidths in the 23-60 GHz range.⁶

The first experimental satellite-to-satellite link was part of the LES 8/9 system.⁷ It employed solid-state ISL transponders at 36-38 GHz for up to 100 kbits/s of data transfer between two satellites up to 40,000 km apart. This experiment proved several new technologies, principally in the area of

D.K. Sachdev has been Manager (R&D) at INTELSAT Executive Organ since October 1978. He is responsible for the formulation and conduct of the INTELSAT R&D Program. Prior to joining INTELSAT, Mr. Sachdev had over 20 years of research and development experience in India with Indian Posts & Telegraphs and Industry. His last assignment was as General Manager (R&D), Indian Telephone Industries, Bangalore, where he had successfully organized one of the largest telecommunication R&D teams in the country. Mr. Sachdev is a Senior Member of IEEE, Fellow IETE (India) and Member AIAA. He was recipient of Vikram Sarabhai Award in 1976 for outstanding contributions in electronics and telecommunications.

millimeter wave transmitters, antenna acquisition, etc. The forthcoming Advanced Westar/TDRSS system¹ will also have a Ka-band intersatellite data link capability.

The global INTELSAT network can derive substantial benefits from intersatellite links in view of its widely dispersed earth stations and multiple satellites in the same ocean region. Therefore it is expected that the ISL technology will become established on a worldwide basis through the INTELSAT network with the exciting future possibility for interconnection of more than one satellite network through ISLs.

In a global network, ISLs could be provided either between two adjacent satellites in the same region or between individual satellites in adjacent regions. The intraregional satellites provide the advantages of eliminating the need for multiple antennas at individual ground stations and of improving the elevation angles from earth stations and the path diversity. In addition, very closely spaced (colocated) satellites provide an elegant solution for simulating a large multipurpose satellite through two smaller ones, thus staggering the investments in time. The development of intraregional ISLs, incidentally, would also provide the necessary technology for interconnection of two different networks in the same region, but that is a question which encompasses issues beyond pure technology development.² On the other hand, inter-regional ISLs would interconnect satellites which are 40°-120° apart and could be useful in the interchange of certain types of traffic. Such ISLs would, however, encounter the difficulties associated with excessive time delay and would require higher power and/or larger antennas than the intraregional ISLs.

For ISLs operating in the recently allocated 23 and 32 GHz bands, three modulation alternatives have been investigated. These are heterodyne, FM remodulation, and regenerative repeaters. The direct heterodyne approach is the simplest but the least efficient, since it suffers from the disadvantage of

backoff requirements of the power amplifier for multiple-carrier transmission and does not trade the available bandwidth for power. The FM remodulation approach converts the multiple carriers into a single wide-deviation carrier occupying nearly 1 GHz bandwidth and has approximately 10-15 dB advantage over the heterodyne approach. It has the added flexibility of providing a tradeoff of capacity vs spacecraft separation distance. The regenerative approach envisions complete demodulation to the digital baseband levels. On the overall transmission level, this approach provides additional flexibility with regard to transponder assignments and permits substantial channel rearrangements within the spacecraft. However, the relevant spacecraft complexity would possibly be justified only when baseband processing reaches the stage of being introduced in the satellite systems as a whole. Figures 1-3 show the capacities and mass impact with the three modulation alternatives. The relative merits are summarized in Table 1.

The ISLs with these characteristics require that several new technologies be developed and space qualified. For the transmitter, 10 W traveling-wave tubes (TWT) are currently being developed at 23 and 32 GHz. Acquisition capabilities of the ISL antenna are also being developed. The most crucial components are the wideband modulator required to FM modulate a 23 or 32-GHz carrier with a multiple-carrier baseband signal of 10-130 MHz and the corresponding demodulator. Figure 4 shows the block schematic of the modem currently under development along with the principal technical objectives.

Digital Satellite Communication

The rapid advances in digital techniques are making a significant impact on practically all segments of communication technology as a whole. In the satellite com-

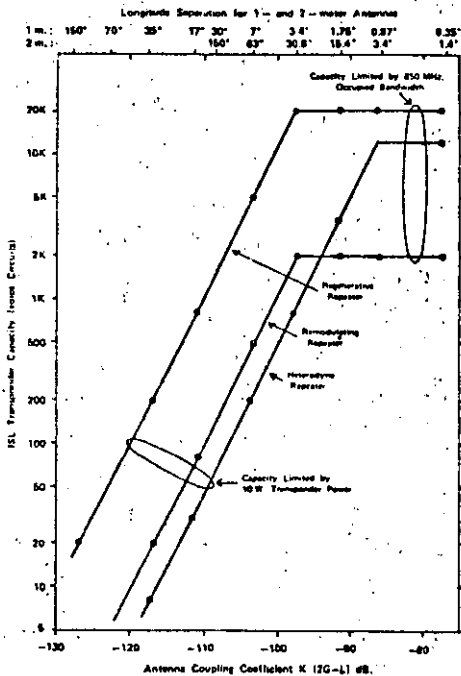


Fig. 1 ISL transponder capacity.

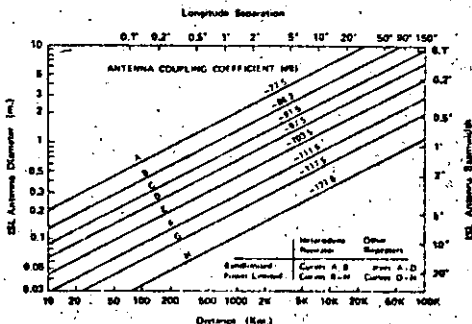


Fig. 2 ISL antenna diameter vs distance.

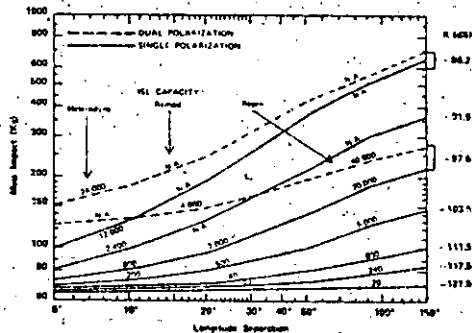
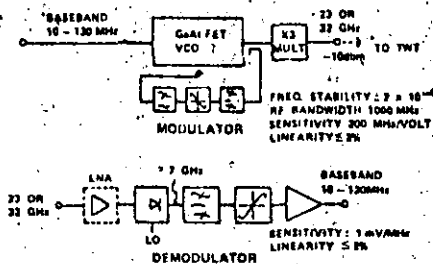


Fig. 3 ISL mass impact vs separation.



MODEM PERFORMANCE

S/N FOR C/N 30 dB: 25 dB (DESIGN GOAL)

Fig. 4. ISL modem.

Table 1. ISL modulation alternatives

Alternative	Advantages	Disadvantages
FM	Operation near saturation Higher spacing for given capacity	Bandwidth inefficient
Heterodyne	Simple translation High capacity at close spacing Least critical technology	Backoff operation Limitations on spacing
Regenerative	Very high capacity Smooth transition to next generation	Requires demodulation onboard Several new technologies

munication field, the applications of digital technology fall into two categories: those common to the communication industry as a whole and those unique to communication satellites. Examples in the first category would be the introduction of PCM multiplex equipment, with or without Digital Speech Interpolation (DSI), digital rearward microwave links, etc. Applications unique to satellites are principally related to the multiple-access capability.

Multiple-zone coverage requires within the spacecraft flexible and efficient means of interconnection between the various zones. Without demodulation onboard, the Frequency Modulation-Frequency Division Multiple Access (FM-FDMA) operation requires N^2 filters for providing full interconnectivity between N zones.¹⁰ Even with a modest number of zones, the weight of these filter networks becomes unacceptable. Further, unless a very large number of zones are employed, it is still necessary to share a typical 40 MHz transponder among a number of carriers, leading to reduction in capacity due to backoff requirements.

The above limitation in the FM-FDMA approach, coupled with advances in digital communication technology, has led to the development of TDMA and SS-TDMA system concepts. By utilizing a single high-speed time-shared carrier in one broadband transponder, TDMA achieves higher capacity compared to FDMA, principally due to its ability to operate near saturation. The interconnectivity between zones is now provided through switching in the time domain-SS-TDMA system.¹¹

The technology for TDMA as well as SS-TDMA has been under development for nearly a decade, and it is expected that during the 1980s a number of operational systems will be introduced.^{8,12-14} In the INTELSAT system, a 60/120 Mbit/s TDMA and SS-TDMA system has gone through several stages of development and field trials. It is envisioned that the first step will be the introduction of TDMA among a small group

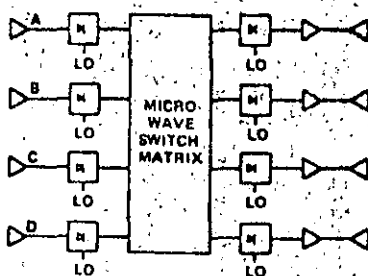


Fig. 5. SS-TDMA block schematic.

of users, principally to relieve saturation of spacecraft capacity and to attain experience with digital systems in an operational environment. The next generation of spacecraft (IS-VI series) which will depend heavily on multiple-beam antennas are expected to have an operational SS-TDMA system.³

Apart from obvious technical differences, FM-FDMA and SS-TDMA systems are suited to different environments. Thus, FM-FDMA systems favor a smaller number of access points per transponder to minimize the backoff requirements, and interconnectivity is provided fairly efficiently so long as global beam operation is acceptable. With multiple reuse of frequency bands through independent zones, the SS-TDMA system has definite advantages in terms of capacity and weight as well as flexibility with regard to interconnectivity. Further, in general, TDMA and SS-TDMA systems favor as large a transponder bandwidth as possible, consistent with the technology requirements in both the space and ground segments.

FM-FDMA and SS-TDMA systems discussed so far have assumed no demodulation onboard the spacecraft and interconnection has been assumed to be at a common, intermediate frequency in both cases. However, the growing complexity of networks; as well as the better performance achievable in all-digital systems through regeneration, has motivated recent efforts toward system studies and hardware development for onboard demodulation/modulation and onboard processing of traffic. Seen as an overall global communication network, this represents a logical step toward the satellites assuming a role more akin to that of a four-wire tandem switch in ground communication networks. This also provides the flexibility of matching the size of each carrier to its traffic as against the requirement in TDMA, where the ground transmitter has to deliver a power which is related to the overall system capacity and is not proportional to the local outgoing traffic. Further, the size and complexity of SS-TDMA matrix at microwave frequencies increases very rapidly with the number of spot beams involved. On the other hand, use of demodulation and regeneration permits achievement of the switching function through inexpensive integrated circuits, even for a large number of beams.

There are several stages—each with its own benefits as well as technological challenges—through which fully flexible onboard processing capability will perhaps be realized. A common denominator in all the approaches is that onboard regeneration leads to better overall performance since this essentially prevents the cumulation of degradation of up- and downlink performance.^{15,16}

Figure 5 shows an SS-TDMA system with a microwave switch matrix (MSM) at RF frequency. Several versions of this configuration are in various stages of realization.^{12-14,17} Such a system would be characterized by efficient interconnection of multiple zones at the intermediate frequency (IF). All users utilize the same transmission rate (typically 60-250 Mbit/s) regardless of the traffic on each link. Such a configuration has the merit of a modest degree of complexity

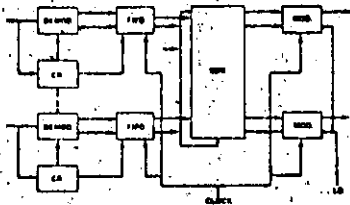


Fig. 6 Baseband switch matrix.

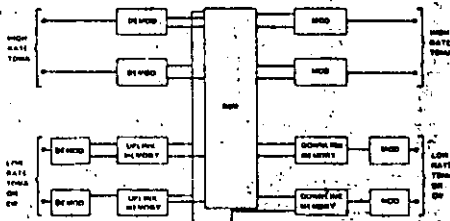


Fig. 7 Hybrid system.

onboard the spacecraft but suffers from the disadvantage of requiring burst, as against continuous wave (CW), transmissions to and from each station at the highest bit rate in the system. Figure 6 shows one version of onboard baseband processing capability. The IF MSM is now replaced by a baseband switch matrix (BSM) which could be realized with high-speed digital integrated circuits and would have a substantial degree of flexibility.

One implicit advantage of the introduction of BSM is that each downlink carrier could now be a CW and thus could carry all of the traffic for a given earth station. In an analogous way, each demodulator could be interfaced to a single earth station. This leads us back to the concept where each earth station could be associated with a pair of frequencies (and filters) onboard the spacecraft. Each station would now radiate digital traffic on one carrier whose size would be matched to its traffic. At the satellite, after demodulation and rearrangement of the bits, all of the traffic for any particular station would be sent down on one carrier which would be uniquely associated with that station. This arrangement provides substantial routing flexibility, so the earth station equipment would no longer need to have the capability to radiate at the highest aggregate bit rate. On the other hand, each station could now have equipment tailored to its own traffic requirements as for FDMA. In a practical situation, with a mix of high- and low-speed traffic, the arrangement shown in Fig. 7 is possibly more suitable.¹¹ High-speed TDMA traffic is demodulated, switched at baseband, and remodulated for transmission to the destination without storage. Low-speed TDMA traffic or nonburst CW traffic is demodulated and stored in uplink memories to await insertion in one or more of the high-rate downlink TDMA bursts.

A discussion on digital satellite communication would be incomplete without at least a reference to the rapid strides in the exploitation of the properties of the signal source itself to reduce the required channel capacity or Source Coding. DSI, already receiving serious attention along with TDMA, can give at least a twofold enhancement of capacity. However, nearly instantaneous companding (NIC) and Adaptive Differential Pulse Code Modulation (ADPCM) hold a promise of providing substantial increases (up to 4 times when combined with DSI) in overall system capacity. Of course, these techniques are by no means unique for satellite communication.

Table 2 Bandwidths derived in 6/4 satellite bands

INTELSAT	Equivalent bandwidth, MHz	INTELSAT	Equivalent bandwidth, MHz
I	25	IVA	720
II	126	V	1480
III	460	VA (planned)	1600
IV	432	VI (planned)	2560

Antenna Technology

Satellite antenna technology began with a single beam covering the whole or major part of the visible position of the Earth and radiating all available frequencies only once. The next step was concentration of the energy over the regions of traffic. With the increasing demands placed on the available frequency bands, consideration was given to reuse of the frequency bands.¹² A measure of the increasing reuse is the equivalent bandwidth being derived from the 500 MHz bands in the 6/4 satellite bands, see Table 2.

This progress has been achieved through advances in practically all subsystems which are put together to form a modern communication satellite antenna subsystem. While the bandwidth utilization efficiency has been steadily increased, the satellite antennas have utilized little or no reconfigurability in space. Thus, the INTELSAT V antenna has the capability at present to realize certain marginal adjustments in the footprints by switching on or off a number of feed elements. Reconfigurability in space could be desirable from several points of view: a flexible spacecraft design capable of optimum performance from several locations in the geostationary orbit, capability to handle either international or domestic/regional traffic, and ability to suppress unwanted interference. The extent of reconfigurability would vary with applications, traffic patterns, etc., and is also to a large extent influenced by the progress in beam-forming technology and the maximum size of realizable antenna reflectors.¹³

The complexity of a reconfigurable antenna depends on the demands which future satellites would place with regard to the size and proximity of the shaped beams, the extent of frequency reuse, and the range of reconfigurable patterns. The first factor decides the size of the component beam, which in turn dictates a certain minimum size of the reflector. The reconfigurability requirements lay down the number of layers of variable power dividers and phase shifters and the complexity of the associated electronics for providing control through ground command. Considerable development work addressing one or more aspects of the multiple-beam reconfigurable antennas (MBRA) has taken place in the past decade. Some of the major results of work being carried out by INTELSAT through its research and development programs are summarized below.^{20,21}

The MBRA technology could provide switching capability for up to 7 identically polarized beams, or 14 beams in all if dual polarization is utilized in each beam. The near-term technology will provide the reduction of interbeam guard spacings below 3 deg for a region at the edge of Earth and about 2.7 deg for regions corresponding to slightly smaller scan angles such as North America and Western Europe. In principle, it should be possible to assign 24 independent transponders for each of the 7-beams, providing a maximum theoretical transponder capability of 168 in the 500 MHz bandwidth using both polarizations. Concurrent with MBRA technology, substantial development work is also underway toward increasing the percentage bandwidth in anticipation of new World Administrative Radio Conference (WARC) allocations: Fig. 8 shows a simplified practical version of a broadband system. The worst case polarization isolation in a $\pm 6.5\%$ frequency band would be better than 30 dB. Typical polarization isolation against the nearest (adjacent) shaped

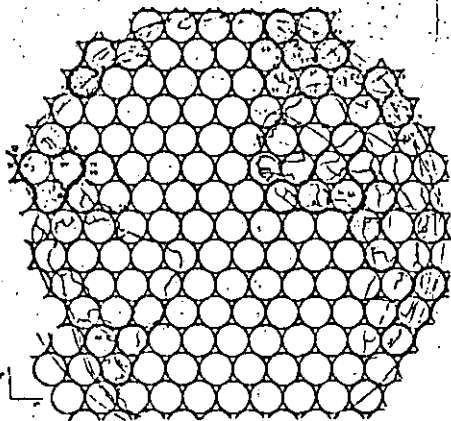


Fig. 8 Antenna coverage beam plan.

beam will be at least 40 dB. This increase in polarization isolation is achieved through newly developed multimode horns with an aperture diameter/wave length ratio of approximately 1.8. In order to confirm the primary and secondary pattern performance of a full-scale MBRA, a representative 140 in. offset reflector with a 16 feed horn cluster is also being constructed.

"Active" Antennas

So far, reconfigurability has been assumed to be achieved after the transponder multiplexers which has the advantage of introducing minimum changes in the payload configuration of current satellites with channelized transponders. However, this calls for fairly heavy beam-forming networks with minimum loss and the capability of handling fairly large amounts of power. This approach could also have limitations from the point of view of dynamically switching a given transponder to more than one beam. These and other system considerations have led to substantial effort in developing "active" or phase-array antennas for communications satellite applications.

Under the "active" antenna concept, the beam forming and reconfigurability is carried out at a lower power level and thus permits the use of miniaturizing techniques such as Microwave Integrated Circuits (MICs) leading to substantial weight savings.²² This approach has the added advantage of control at much higher speeds—a fundamental requirement of the "scanning spot" beam satellites under consideration for contiguous coverage areas typical of highly developed domestic networks.²³

Other areas of investigations in the antenna field expected to have significant impact on the performance of satellites being developed during the 1980s are efforts toward increased minimum coverage gain for global antennas, improvements in software and design tools, and progress in materials and mechanical features of the new generation antennas.²⁴

Transponder Technology

Concurrent with the development of newer system concepts and their associated hardware, there have been substantial efforts industrywide toward improving the performance, weight, and reliability of the transponders. One notable example, now reaching a level of maturity, is graphite epoxy lightweight filters and contiguous band filters. In the near future, it is anticipated that a significant impact will be made by the rapidly growing gallium-arsenide field effect transition (GaAs FET) technology. These devices are challenging practically every available "slot" in the transponder, ranging

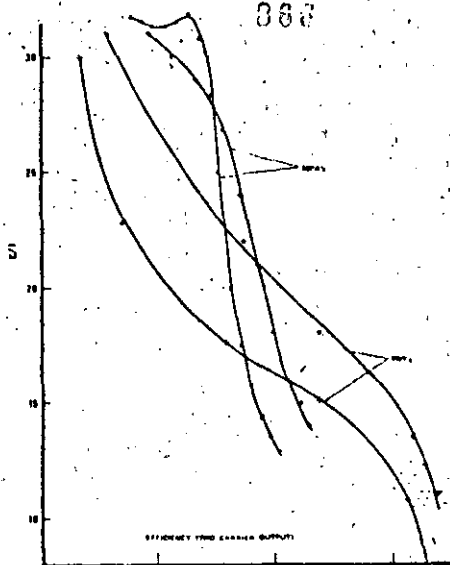


Fig. 9 Comparative performance of TWTs and SSPAs.

from low-noise front-end amplifiers, switching matrices both at IF and baseband, high-power amplifiers, etc.²⁵

For the output stages, traveling-wave tubes (TWTs) have been the mainstay of communication transponders from the beginning of satellite communication. TWTs, notwithstanding their excellent record, have a finite life and substantial amount of work has been underway for nearly a decade to evolve their solid-state replacements. While IMPATT diodes have an edge at frequencies above 20 GHz, the real impact at bands of immediate interest is being made by the GaAs FET amplifiers.²⁵⁻²⁸ When replaced one for one, FETAs compared to TWTAs are expected to provide comparable efficiencies, better intermodulation (IM) products, smaller volume, and simpler power supplies. Figure 9 shows the comparative performance of two each of state-of-the-art TWTs and solid-state amplifiers.

In the longer perspective, several approaches to the optimum utilization of solid-state power stages are under various stages of development. Thus, solid-state amplifiers, unlike TWTs, can be optimized for IM and efficiency at a range of output power levels. Several approaches to linearization of the amplifiers, some of them common with TWTs, are currently receiving serious attention. These include push-pull operation, predistortion,²⁹ and feedforward. The possibility of substantial distortion reduction through negative feedback at microwave frequencies is a technological challenge demanding development of monolithic amplifiers with extremely small forward propagation delays. Concurrent with the development of "conventional" solid-state power amplifiers is the substantial activity related to the active antenna field referred to above. The latter would receive substantial impetus if wideband, low-distortion, medium-power (0.5-1 W) amplifier modules become a reality in the near future.

Spacecraft Technology

The principal aspects of the spacecraft technology briefly considered here are the advances in power generation and storage techniques, the impact of launch capabilities on spacecraft design, and attitude and orbit control subsystem requirements.

Power Generation Technology

To date commercial communication satellites have employed solar cells for primary power generation. Increases in spacecraft size, and the consequently higher total power demand, now dictate that the cells be mounted on deployable arrays. The present total power demand (1 kW for INTELSAT V) can be met by the use of two deployed wings, each subdivided into several rigid panels.

The structure of rigid panels consists in most cases of honeycomb cores covered with sheets of fiber-reinforced polyimide foils. The stiffness of rigid panels prevents excessive vibration during launch and gives a stable configuration in orbit. However, the high weight of the panel structure will limit use of such panels to satellites not requiring more than 1.5 kW. Specific power densities attainable are typically 20 Wkg^{-1} and only considerable improvements in solar cell performance can extend this to 25 Wkg^{-1} .

Alternative lightweight arrays have been under investigation for several years, and their further development is critical for the spacecraft of the 1980s. They can be categorized as either semirigid or flexible. Semirigid arrays are based on a thin substrate foil mounted in a rigid frame. Representatives of this type are the GSR and Ultra Light Panel (ULP) manufactured by Aerosphale and by Messerschmitt-Boelkow-Blohm (MBB), respectively, with a proved attainment of 30 Wkg^{-1} . As before, the use of a more weight-efficient solar cell would increase this figure of merit—possibly to 50 Wkg^{-1} . Work on fully flexible arrays has already demonstrated that $\geq 100 \text{ Wkg}^{-1}$ is feasible for systems requiring 5 kW. Conceptual designs here include retractable roll-out and fold-out types.

It will already be clear that a second key development in this area will be the evolution of ever more weight-efficient solar cells. This target becomes steadily more critical as the weight of the array-substrate, support, etc., is itself reduced. Two major developments will emerge during the early 1980s. Thin substrate/thin coverslide ($50 \mu\text{m}$ each typically) cells, which have already been demonstrated to be fully compatible with several of the advanced arrays, will doubtless begin to incorporate the many efficiency optimization features now included, and proved for standard, thicker substrate devices (textured front surface fields, etc.). This will usefully supplement the present rather low efficiencies obtained from $50 \mu\text{m}$ cells, while retaining the better radiation hardness typical of these devices. While the major part of this effort will involve cells fabricated from silicon, there will also be attention given to alternative materials. Gallium-arsenide cells for example, offer a better maximum efficiency, a reduced temperature coefficient of efficiency, and considerably better performance in a radiation environment than conventional silicon units. The use of compound semiconductor devices with concentrating arrays may also become attractive.

Power Storage Technology

The provision of power enabling full-operational capability during the eclipse seasons has normally been achieved through the use of batteries. The sealed nickel-cadmium (Ni-Cd) battery has been used in all INTELSAT spacecraft to date. Currently (on INTELSAT V) the requirements made at the Ni-Cd units include: a minimum of 1000 charge/discharge cycles during 7 years from a battery of 30-35 Ah capacity, the discharge rate being no greater than $c/2$. Given the results of detailed investigations on Ni-Cd cells, these requirements appear feasible, providing that the depth of discharge is itself limited (to approximately 50%) and strict temperature control of the battery is maintained. The information obtained from recent analyses of performance degradation in Ni-Cd cells does not however lend support to the notion that any sizeable further step in operational capability can be obtained from Ni-Cd units. Doubtless efforts will continue to improve their overall reliability and stability, hinging on both optimization

of the cell components as well as on improved routines for operational management through the early 1980s. Particular attention will have to be paid to the chemical stability of the separator and the microstructural properties of the negative (Cd) electrode. Hydrolysis of nylon separator material leads to loss of overcharge protection in Ni-Cd cells, and cadmium migration from the negative plate to a loss of overall capacity. Operationally there is much current emphasis on reconditioning.³⁰

Partly in response to the difficulties which are encountered with Ni-Cd units, INTELSAT has sponsored the development of nickel-hydrogen (Ni-H₂) batteries. Successive R&D programs, spanning 6 years, have been concerned with cell and battery design and component development. It was appreciated very quickly that the Ni-H₂ system has several internal advantages compared to Ni-Cd cells, including built-in overcharge protection, a good overdischarge capability, and an easily optimized energy density.³¹ Excellent performance over 3000 cycles from 50 Ah cells at 75-80% depth of discharge can be predicted from laboratory results.³² This will be available at a usable energy density at 35-40 Wh/kg^{-1} . By comparison, Ni-Cd batteries can offer only 15-20 Wh/kg^{-1} . The good performance and resistance to degradation of the Ni-H₂ battery has been fully confirmed by flight experience to date. A 35-Ah battery supplied by INTELSAT has provided power for the NTS-2 spacecraft for five eclipse seasons since its launch in June 1977. Data from this battery and another of the same design being run under pseudo-geostationary orbital conditions have been carefully analyzed. The performance of both batteries has been strictly according to demand. Current consideration is being given to the incorporation of 30 Ah Ni-H₂ batteries on the later flight models of the INTELSAT V spacecraft series, involving the technology developments and operational data outlined here. The ultimate cell performance capabilities and fabrication technology are not yet fully optimized however.

Further developmental work will be continued in order to meet the more demanding requirements of future generations of spacecraft. Topics likely to be addressed are: better thermal control of the cell stack; further optimization of component performance (in particular the positive (Ni) electrode and the separator), and the full development of 50-60 Ah cells. Figure 10 shows the goals of some of the current and planned programs.

Launch Vehicles

Satellite system planners, particularly those who have been associated with successive generations of spacecraft, find the

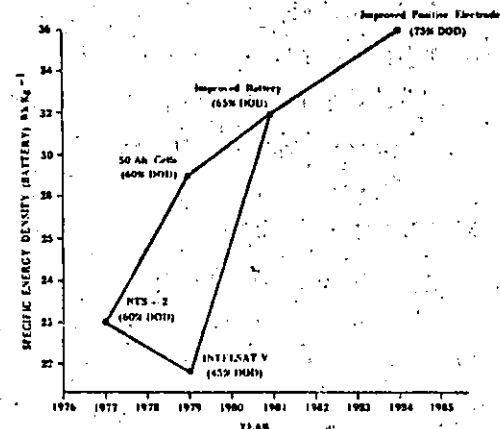


Fig. 10 Nickel-hydrogen battery design objectives.

present launch environment quite an enigma. On the one hand, we possibly have more choices than ever before and are at the beginning of the era of "cheap space freighter service." On the other hand, the plethora of uncertainties which presently characterize the various programs are of such a magnitude that satellite system designers are finding it extremely difficult to commit themselves to any particular bus approach for the coming decade. However, there is every reason to be optimistic about the inherent strength of the aerospace community to lift the clouds and soon provide the promised family of launch vehicles and systems.

The principal candidate launchers for the future generations of INTELSAT spacecraft are the U.S. STS (Shuttle) and the French ARIANE. With its 1700 kg initial geosynchronous transfer orbit payload capability, ARIANE, whose launch and ascent sequence is similar to that of existing launchers (Delta, Atlas-Centaur), can meet the requirements of future spacecraft. A substantial difference is introduced by the Shuttle for launch and ascent sequence as well as payload weight and volume constraints: The Shuttle can place a payload with a cylindrical envelop of 4.5 m diam and 18 m length and with weight of 27,000 kg in low Earth orbit. This leaves ample room (and therefore many options) to the choice of a stage vehicle for transferring the spacecraft from the Shuttle orbit to its geosynchronous orbit station.³³

Options presently being considered include: traditional satellite design, integral with an apogee kick motor (AKM) and separate perigee stage, transfer (perigee/apogee) stage with separate satellite, and integral satellite/transfer stage. Within each of these configurations, alternative tradeoffs are available with the choice of solid or liquid propulsion systems. The IUS could be a candidate for the second option, but alternative simpler, more cost-effective approaches are being investigated.

While the choice of solid motors for the transfer vehicle leads to the classical Hohmann (elliptical) transfer, intriguing new problems arise with the choice of liquid propellants and motors of lesser thrust. As the burn time required for the delivery of a given perigee and apogee total impulse varies inversely in proportion to the corresponding available thrust, the impulse approximation and therefore a Hohmann transfer approach can still be implemented with liquid motors, provided the perigee/apogee burns (at constant altitude) are broken into a number of pulses which progressively raise the respective apogee/perigee. This is particularly true for the perigee burn where the true anomaly varies much more rapidly than at apogee. A drawback of the multipulse approach is the resulting extended time of the spacecraft in transfer orbit with its impact on spacecraft power and thermal system requirements. Another drawback is that, because the time-related practical limitation on the number of pulses, efficiency degradation in each burn with respect to the impulsive approximation must be tolerated.

The alternative of low-thrust, continuous burn at non-constant altitude (perhaps along the gravity turn) is a way of expediting the transfer and maximizing the efficiency of the stage, but it requires a guidance package. These approaches are actively being considered and are part of current INTELSAT R&D activities.

Altitude and Orbit Control Subsystems

In the area of attitude and orbit control, advances continue to be made both at subsystem and component levels. From the earlier spin-stabilized configurations, the attitude control subsystem (ACS) of the INTELSAT series has evolved into the bias momentum body-stabilized configuration of INTELSAT V and other spacecraft.

To satisfy the requirements of high reliability over a life span of 7-10 year, multiwheel configurations have been studied, and a skewed, four-wheel ACS engineering model has been produced and tested on an air-bearing facility.³⁴ To meet higher pointing accuracy requirements, an integrated

three-axis attitude-sensing system engineering model has also been developed and tested on an air-bearing table.³⁵ The system use; one or two rate integrating gyros, updated by Earth and sun sensors, and Kalman filtering for an accurate estimate of the attitude errors. In the near future, multisensor arrangements (optical as well as inertial) with integrated microprocessing will be evaluated for a reliable, fault-detective, accurate sensor system.

The rapid size increase in appendages such as solar arrays and antennas is motivating substantial work in the area of flexible spacecraft control. The constant demand for increasing spacecraft power will require larger solar arrays. This fact, coupled with improvements in the structural materials and in the power/weight ratio of advanced solar generators, will result in structural flexibilities for which the lowest modal frequencies may no longer be immune from ACS interaction and self-excitation. Similar considerations apply to larger antennas and their support structures. In the expectation of potentially dangerous ACS-flexible spacecraft interactions, techniques are being studied for the design of improved control configurations employing distributed sensing and perhaps multiple actuators and judicious onboard processing.

At the component level, significant advancement has been achieved in the area of high-speed momentum wheels. The elimination of mechanical friction by means of magnetic suspension and the development of high-strength rotors fabricated with beryllium or composite materials has made possible the implementation of reliable, lightweight momentum wheels with speeds up to 40,000 rpm. Two different magnetic bearing concepts have been developed, one radially passive and axially active, the other fully active.

Advanced work in the area of spacecraft control will address the possible application of high-speed momentum wheels both for energy storage (electromechanical battery) and for attitude control. A wheel energy storage system is presently being investigated under contract. The contract will address both the power management aspects and the ACS/dynamics interaction of such a system, and will produce an engineering model of a component wheel capable of storing up to 0.5 kWh with a target energy density of 35 Wh/kg.

Space Platforms

The expected availability during the 1980s of economical launch of significantly large payloads by STS has motivated several studies of large space platforms.³⁶⁻³⁸ While the definition of what is "large" is obviously a variable with time, the term "platform" has come to connote a geostationary structure with multiple ownership (or users) and with a capability of preventive addition and/or replacement of parts of the payloads.

From a purely technological point of view, such platforms are attractive if they lead to reduction in the cost of, say, the unit transponder and, preferably, also increase the efficiency of the utilization of the orbital arc. While applying the first criterion, considerable caution needs to be exercised when comparing costs at comparable points of time and equivalent technological maturity for the two options. Under the criterion of orbital arc efficiency, the comparison is between a large multifrequency platform against a cluster of collocated satellites.³⁹ The platform concepts obviously suffer from the lack of flexibility of individual satellites but could end up being more efficient frequency-wise, if efficient interconnectivity is provided between a number of users. Obviously, the tradeoffs will evolve in the next few years and will in turn be heavily influenced by the evolution of STS and the associated propulsion systems required to reach the geostationary orbit.

Conclusions

In less than two decades, satellite communication has more than matched the exacting technical as well as reliability challenges from the global communication world. Such a

success record could lead one to relegate the satellite technology to a "stable" category and concentrate instead on reaping the benefits of the long-term and massive investments in technology by ordering "more of the same." However, as this brief survey has attempted to project, the technology is far from stable and the coming decade should see still bigger advances, though none of them will seem to be as spectacular as the SYNCOM which realized Arthur Clarke's dream.

One notable advance could be the intersatellite links. The technology development programs are well underway and should provide the building blocks in less than 3 years. Whether at the end of that period ISLs will be in commercial use is a complex function of the traffic growth, investments in ground segments, and the launch environment. Surprisingly, a very high degree of success in launch vehicles could push ISLs a bit further into the future by improving the viability of space platforms! One aspect of ISLs which does require a serious look is their capability to interconnect different networks.^{9,39} This important role justifies development of international standards for the principal ISL parameters.

There is probably no longer any uncertainty about digital technology ultimately becoming the technology for the whole communication world. In the satellite communication world, at least in the author's view, it is already "overdue." Since a major change in the space segment technology occurs only at widely spaced intervals synchronized with the procurement of next generation spacecraft, the next major generation due in the mid-1980s is positively the last opportunity to go digital in a big way if we do not want to lose a major portion of the market to competitive media. In specific areas, TDMA and SS-TDMA technology are ready for system applications and could be followed closely on their heels by baseband processing.

If there is one subsystem going through revolutionary (and visible) changes in the space segment, it is the spacecraft antenna subsystem. The technology has come a long way from the stage when a spacecraft antenna was a simple interface with space. Today's and more so tomorrow's satellites are complex farms of antennas and feeds which account for a very large fraction of satellite mass, volume, and investment.²⁴ And this is even before the stage of exploitation is achieved to any reasonable degree, to reap the significant benefits from reconfigurability and the whole new field of active antennas!

In the transponder technology, possibly the most significant change in the near term will be the replacement of the TWTAs by solid-state FET amplifiers. In fact, the transponders of the next generation could well be all FETs. The next step could possibly be greater utilization of monolithic technology in various parts of the transponder. The resultant benefits in terms of lower mass, better reliability, and higher linearity could be significant.

The payloads of future satellite generations will be far more complex not only in terms of transponders but also due to introduction of RF/IF dynamic switching as well as storage and processing of baseband. This significant increase in the parts count; if not adequately planned for, could lead to reduction in reliability below acceptable limits. It is interesting to recall that the parts count in every successive INTELSAT spacecraft has increased by a factor of three.⁴⁰ With the added complexity, this multiplier factor could be even higher for the next generation. In order to continue to meet the exacting reliability requirements, some of the measures under consideration include: significantly higher level of integration, development of monolithic low-power analog subsystems such as microwave receivers, and reduction of control hardware through distributed processing techniques and microprocessors.

The spacecraft technology encompasses a wide range of disciplines, some of which have been touched upon here. While advances in solar power generation and storage will provide the necessary capability to match future requirements, the one big challenge is adjustment to the

rapidly evolving launch capabilities, not excluding their current uncertainties.

Finally, the diverse developments in practically all aspects of spacecraft design definitely promise an exciting period of technological developments across the board, not counting the sleepless nights many program managers will go through grappling simultaneously with so many new techniques!

Acknowledgments

The work reported here emanates largely from the efforts of a worldwide community of engineers and scientists associated in one way or another with successive INTELSAT R&D programs. I wish to particularly acknowledge the advice of my colleagues at INTELSAT as well as several engineers and scientists at COMSAT Labs. Substantial contributions have been made by Giacomo Porcelli, Bill English, John Stevenson, Joe Campanella, and George Welti.

References

- ¹ Bargellini, P.L. and Edelson, B.I., "Progress and Trends in Commercial Satellite Communications—A Survey," *Proceedings of International Astronautical Congress, Lisbon, 1975*, edited by L.G. Napolitano, Pergamon Press, Oxford, England, 1976, pp. 259-276.
- ² Davis, R.C., Esch, F.H., Palmer, L., and Pollack, L., "Future Trends in Communication Satellite Systems," *Acta Astronautica*, Vol. 5, March-April 1978, pp. 275-298.
- ³ Granger, R.L. and Chitre, N.K.M., "Post-INTELSAT V Systems Planning," *Western Electronic Show and Convention (WESCON)*, San Francisco, Sept. 1979.
- ⁴ Barry, J.D., Danen, A., Dawkins, B.T., et al., "1000 Mbits Intersatellite Laser Communication System Technology," *IEEE Transactions on Communications*, April 1976, pp. 470-478.
- ⁵ Maynard, J.A., Ross, M., and Wolf, J.D., "Multi Gigabit Laser Communications for Satellite Cross Links," *Proceedings of Fourth International Conference on Digital Satellite Communications*, Montreal, Oct. 1978, pp. 155-159.
- ⁶ Welti, G.R., "Intersatellite Link for Multiple Access Telephone," *Electronics and Aerospace Systems Convention (EASCON) '78 Record*, pp. 432-440.
- ⁷ Solman, F.J., Berglund, C.D., Chick, R.W., and Clifton, B.J., "The Ka-Band Systems of the Lincoln Experimental Satellites LES-8 and LES-9," *Proceedings of 7th AIAA Communications Satellite Systems Conference*, 1978, pp. 208-215.
- ⁸ Holmes, W.M., "The Tracking and Data Relay Satellite System," *Proceedings of 7th AIAA Communications Satellite Systems Conference*, 1978, pp. 158-164.
- ⁹ Wood, H.W., "Long-Term Design Objectives for Communication Satellites," *Design News*, Vol. 36, July 7, 1980, pp. 82-91.
- ¹⁰ Garner, W.B., "A System Comparison of Satellite Switched TDMA and FM-FDMA for Multi-beam Satellites," *Proceedings of Second International Conference on Digital Satellite Communications*, Paris, 1972, pp. 441-449.
- ¹¹ Dill, G.D., Tsuji, Y., and Muratani, T., "Application of SS-TDMA in a Channelized Satellite," *Proceedings of International Conference on Communications*, Vol. 3, 1976, pp. 51.1-51.5.
- ¹² Assal, F. and Rozec, X., "Fast, Fully-Redundant 4 GHz, 8 x 8 Microwave Switch Matrix for Communication Satellites," *Proceedings of Ninth European Microwave Conference*, 1979, pp. 218-222.
- ¹³ Campanella, S.J. *private communication*.
- ¹⁴ Campanella, S.J., Colby, R.J., Pontano, B.A., Suyderhoud, H., and Onufry, M., "The INTELSAT TDMA Field Trial," *COMSAT Technical Review*, Vol. 9, Fall 1979, pp. 293-340.
- ¹⁵ Campanella, S.J., Assal, F.T., and Berman, A., "On-Board Regenerative Repeaters," *Proceedings of International Conference on Communications*, Vol. 1, 1977, pp. 6.2-121 to 6.2-125.
- ¹⁶ Fiorica, F., "Use of Regenerative Repeaters in Digital Communications Satellites," *Proceedings of 7th AIAA Communications Satellite Systems Conference*, 1978, pp. 524-532.
- ¹⁷ Ramasastry, J., Heiser, W., Levine, E., and Markham, R., "Western Union's Satellite-Switched TDMA Advanced Westar System," *Proceedings of 7th AIAA Communications Satellite Systems Conference*, 1978, pp. 479-506.
- ¹⁸ Kreutel, R.W., Difonzo, D.F., English, W.J., and Gruner, R.W., "Antenna Technology for Frequency Reuse Satellite Communications," *IEEE Proceedings*, Vol. 65, March 1977, pp. 370-378.
- ¹⁹ Foldes, P., Meier, R., and Afifi, M., "Multiple Beam Satellite Antennas," *Proceedings of 7th AIAA Communications Satellite Systems Conference*, April 1978, pp. 391-399.

- ²⁰Foldes, P. and Berkowitz, M., "A Reconfigurable Multibeam Antenna for Satellite Communications," *Proceedings of Third World Telecommunication Forum, ITU*, Sept. 1979, Pt. 2, pp. 1.5.6.1-1.5.6.12.
- ²¹Foldes, P., "Control Aspects of Multibeam or Multielement Spacecraft Antennas," *Proceedings of International Telemetering Conference*, Vol. 15, 1979, pp. 131-144.
- ²²Difonzo, D.F., Karmel, P.R., and Atia, A.E., "A Multiple Shaped Beam Reconfigurable Satellite Antenna," *International IEEE/AP-S Symposium*, 1979, Vol. 2, pp. 457-460.
- ²³Keudink, D.O. and Yeh, Y.S., "Rapid Scan Area-Coverage Communication Satellite," *Proceedings of 7th AIAA Communications Satellite Systems Conference*, 1978, pp. 137-145.
- ²⁴English, W.J., "Improving Future Communications Satellite Antenna Designs," *Proceedings of 8th AIAA Communications Satellite Systems Conference*, 1980, pp. 464-470.
- ²⁵Cuccia, C.L. and Ho, P., "The Impact of the FET on the Satellite Transponder—A Technology Prospective," *Proceedings of 7th AIAA Communications Satellite Systems Conference*, 1978, pp. 172-181.
- ²⁶Ho, P.T., Rubin, M.D., and Wherry, J.G., "Solid-State Amplifiers in Communication Satellites," *Proceedings of 7th AIAA Communications Satellite Systems Conference*, 1978, pp. 182-187.
- ²⁷Cuccia, C.L., Ho, P.T., and Rubin, M.D., "TWTA versus FETA in Communication Satellite Transponders," *Proceedings of INTELCOM 79*, pp. 412-415.
- ²⁸Drago, F., Hawley, J., Huang, H., and Sochi, F., "C-Band FET Power Amplifier for TWTA Replacement," International Astronautical Federation, Paper 79-310 presented at International Astronautical Congress, Munich, 1979.
- ²⁹Markle, R.E., "The AR 6A Single Sideband Long-haul Radio System," *Proceedings of International Conference on Communications*, 1977, Vol. 3, pp. 40.1-78 to 40.1-82.
- ³⁰*Proceedings of the Goddard Space Flight Center Battery Workshops*, 1977, 1978.
- ³¹Patterson, R.E., Luft, W., and Dunlop, J.D., "Development of Spacecraft Power Systems Using Nickel Hydrogen Battery Cells," AIAA Paper 76-288 presented at 6th AIAA/CASI Communications Satellite Systems Conference, 1976.
- ³²Dunlop, J.D. and Stockel, J.F., "Orbital Performance of NTS-2 Nickel-Hydrogen Battery," *COMSAT Technical Review*, Vol. 7, Fall 1977, pp. 639-647.
- ³³Spencer, T.M., Glickman, R., and Porcelli, G., "Changing Inclination for Shuttle Payloads," *Journal of Guidance and Control*, Vol. 2, July-Aug. 1979, pp. 264-270.
- ³⁴Ramos, A., "Air Bearing Testing of a Skewed Reaction Wheel System for Attitude Control," *COMSAT Technical Review*, Vol. 9, Spring 1979, pp. 157-202.
- ³⁵Anstett, P. and Govin, B., "Study of an Integrated Attitude Sensing System and Development of a Prototype," *Automatic Control in Space; Proceedings of the 8th Symposium*, Pergamon Press, Oxford, England, 1980, pp. 257-265.
- ³⁶Edelson, B.I. and Morgan, W.L., "Orbital Antenna Farms," *Astronautics and Aeronautics*, Vol. 15, Sept. 1977, pp. 20-29.
- ³⁷Fordyce, S. and Staminger, R., "The Use of Geostationary Platforms for Future U.S. Domestic Satellite Communications," *Proceedings of International Conference on Communications*, 1979, Vol. 3, pp. 49.4.1-49.4.5.
- ³⁸Pelton, J.N., "Is There a Space Platform in INTELSTAT's Future? Facing the Institutional Challenges of the 1980's and 1990's," *Proceedings of 8th AIAA Communications Satellite Systems Conference*, 1980, pp. 408-411.
- ³⁹Visher, P.S., "Satellite Clusters," *Satellite Communications*, Vol. 3, Sept. 1979, pp. 22-27.
- ⁴⁰Strauss, R. and Owens, J.R., "Design Factors Affecting Communications Satellite Lifetime," Paper 77-21 presented at International Astronautical Federation 28th Congress, Prague, Oct. 1977.

From the AIAA Progress in Astronautics and Aeronautics Series . . .

VISCOUS FLOW DRAG REDUCTION—v. 72

Edited by Gary R. Hough, Vought Advanced Technology Center

One of the most important goals of modern fluid dynamics is the achievement of high speed flight with the least possible expenditure of fuel. Under today's conditions of high fuel costs, the emphasis on energy conservation and on fuel economy has become especially important in civil air transportation. An important path toward these goals lies in the direction of drag reduction, the theme of this book. Historically, the reduction of drag has been achieved by means of better understanding and better control of the boundary layer, including the separation region and the wake of the body. In recent years it has become apparent that, together with the fluid-mechanical approach, it is important to understand the physics of fluids at the smallest dimensions, in fact, at the molecular level. More and more, physicists are joining with fluid dynamicists in the quest for understanding of such phenomena as the origins of turbulence and the nature of fluid-surface interaction. In the field of underwater motion, this has led to extensive study of the role of high molecular weight additives in reducing skin friction and in controlling boundary layer transition, with beneficial effects on the drag of submerged bodies. This entire range of topics is covered by the papers in this volume, offering the aerodynamicist and the hydrodynamicist new basic knowledge of the phenomena to be mastered in order to reduce the drag of a vehicle.

456 pp., 6 x 9, illus., \$25.00 Mem., \$40.00 List

TO ORDER WRITE: Publications Dept., AIAA, 1290 Avenue of the Americas, New York, N.Y. 10104

871

412

INTELSAT VI - a 50 - channel
communication satellite with SS - TDMA

por N.M.F. Wong
Hughes Aircraft Company



INTELSAT VI - A 5th CHANNEL COMMUNICATION SATELLITE WITH SS-TDMA

NORMAN M. F. WONG

Intelsat VI Systems Engineering Manager

Hughes Aircraft Company
Space & Communications Group
Box 9219, Airport Station
Los Angeles, CA 90019

ABSTRACT

Intelsat VI represents the largest commercial communications satellite project ever undertaken. The spacecraft bus employs a wide diameter spinner with an extended solar panel similar to that of the Hughes HS376 Spacecraft. It is compatible with both the Ariane and STS launch vehicles. The satellite features built-in growth capability in several areas.

The communications repeater operates at C band and K band and features an onboard microprocessor controlled TDMA system. Six-fold reuse frequency is accomplished by precise forming of narrow antenna beams coupled with high polarization isolation. The spacecraft incorporates both a beacon tracking system and a sun/earth sensor pointing system to automatically maintain pointing accuracy to better than 1.5°. The program began in April 1982, and the first of five flight spacecraft will be delivered at the end of 1985.

INTRODUCTION

The Intelsat VI series of satellites is a new generation of communication satellites being built for launch in the mid 1980's. The five satellites in the series are procured by the International Telecommunication Satellite (Intelsat) Organization, whose contractor is Hughes Aircraft Company of El Segundo, California. The satellites will be placed in geosynchronous orbit over either the Atlantic, the Pacific, or the Indian Ocean Regions. They are compatible with the existing Intelsat V system and will supplement and eventually replace its present fleet of Intelsat V spacecrafts with an increased capacity of approximately 80,000 one-way telephone channels plus two television channels.

Intelsat VI is a spin stabilized satellite whose mass and size are designed to be compatible with either the Ariane 4 launch vehicle or the Space Transport System (STS). It has an extendable solar array panel that will provide over 2000 watts of bus power after ten years in synchronous orbit. Nickel-hydrogen batteries will be used to supply spacecraft power through eclipse and the launch sequence. The C and K band antennas will be stowed during launch and deployed after the satellite reaches synchronous orbit.

The launch vehicle payload has a mass of 11,500 kg, which includes a cradle and a perigee kick motor (PKM) for the STS launch and 3,700 kg for the Ariane launch. A liquid bipropellant system will provide the stationkeeping functions as well as the apogee boost maneuver. Sufficient propellant will be provided to maintain a 10-year mission life while preserving an orbital position stability of $\pm 0.1^\circ$. A beacon tracking receiver will be used in addition to the sun and earth sensors in a closed loop system to maintain platform despun motor control. This receiver will also provide continuous control for maintaining antenna pointing.

The communications payload consists of 50 repeater channels at the C and K bands. A distinctive feature of the Intelsat VI is the dynamic Satellite Switched Time Division Multiple Access (SS-TDMA) System, which makes it possible to interconnect six antenna-isolated coverage areas. It is also possible to interconnect the C band and the K band channels through static switches for dedicated traffic patterns. Practically all active units are redundant to give a high overall spacecraft reliability. Possible types of transmission using the spacecraft are FDM/FM/FDMA for voice, FM monochrome or color television, or PCM/QPSK/TDMA and SCPC/QPSK/TDMA.

SPACECRAFT CONFIGURATION

The spacecraft is divided into spun and despun sections which are interconnected by a bearing and power transfer assembly (BAPTA) as shown in Figure 1. During launch the two sections are locked together at their periphery to minimize load transfer through the bearing assembly. The spun section is composed of the spun structure, solar panel assembly, aft thermal barrier, bus electronic equipment, and liquid bipropellant subsystem. The central shear tube provides a common attach interface to both the Ariane 4 and STS adapters as well as a convenient mounting surface for the propulsion lines and components. The eight liquid propellant tanks are located for direct mounting to the aft shear tube ring minimizing loads interaction with the main structure. Four 22 N radial thrusters are mounted on the spun shell with their nozzles aimed through cutouts in the solar panel. In addition, two 22 N axial thrusters and two 490 N apogee thrusters are mounted at the aft end of the spacecraft. Nickel-

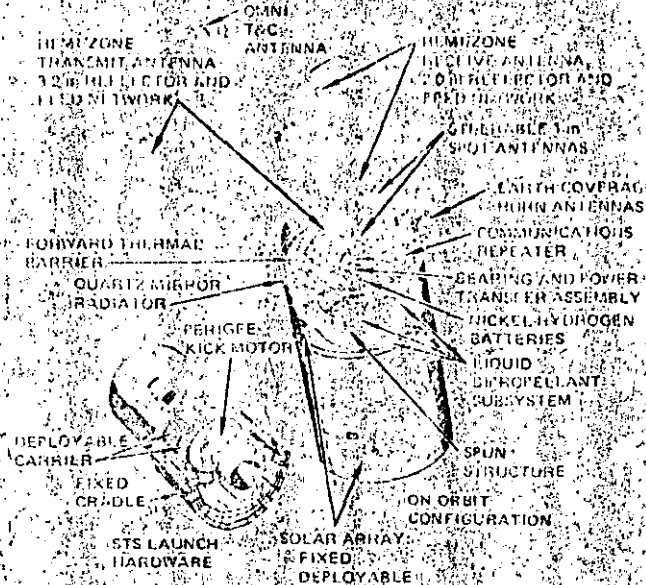


FIGURE 1. INTEL SAT VI SPACECRAFT ELEMENTS

hydrogen batteries are mounted on a shelf within the aft portion of the tube, which provides a low temperature environment. The solar panel assembly is lightweight Kevlar/honeycomb. The fixed panel uses K4-3/4 cells for better temperature control of the bus subsystems, whereas the aft (telescoping) panel uses K7 cells for higher power output. The mirrored radiators on the solar panel provide radial heat rejection, thus minimizing back radiation and shadowing from the extensive despun antenna farm.

The despun section consists of the antenna subsystem and support structure, the despun forward barrier, and the despun shelf. The C band reflectors and feeds are supported on the despun shelf structure, which provides the required stiffness and thermal stability. The K band antennas with their feeds and the global horn assembly are mounted on bracketry that is tied directly to the shelf.

The despun shelf has a flat circular section, a cylindrical rim, and a narrow annular shelf that can be expanded for growth. The high dissipating units (traveling wave tube amplifiers and solid state power amplifiers) are mounted on the outside surface of the rim shelf to provide close proximity to the mirrored radiator on the solar panel. The top of the circular shelf contains the output multiplexers and the beacon transmitters. The bottom side is used for units requiring RF isolation such as the input multiplexers, switch matrices, receivers, and telemetry and command hardware. The annular shelf contains only the output multiplexers for zones 1 and 3. This overall arrangement provides easy access for integration and testing of the repeater hardware.

Some significant characteristics of the spacecraft design are shown in Table 1.

MISSION SEQUENCE

The spacecraft bus design is optimized within the diameter and launch weight constraints of the

Ariane 4 while maintaining STS launch efficiency. This is accomplished by stowing the large C band reflectors in a compact arrangement for launch and by using a telescoping solar panel design. A cradle supports the spacecraft and the perigee stage with the spin axis along the Orbiter bay. Separation from the Orbiter is achieved by a Prisbee ejection technique that imparts both a translation and a stabilizing rotation to the ejected payload. A PKM is required in the STS launch to boost the spacecraft into an elliptical transfer orbit. An apogee boost rotor is used in both launches to place the spacecraft into final synchronous orbit. The mission sequences of both types of launches are shown in Figure 2. For the STS launch, the spacecraft is initially transported to a 296 km circular parking orbit, with the Orbiter oriented to the required PKM firing attitude. Forty-five minutes before the selected injection opportunity, the spacecraft is separated from the Orbiter by the Prisbee ejection method. A post-ejection sequencer (PES) automatically initiates omni antenna deployment, spinup, and subsequent PKM firing, which injects the spacecraft into an elliptical transfer orbit.

Once the spacecraft is acquired from the ground, spin speed adjustments are made, the spacecraft platform is unlocked, and the platform and rotor spin rates are adjusted to a "super-spin" condition. This permits the propellant slosh dissipation to act as a stabilizing influence on the spacecraft, thus eliminating the need for thruster nutation control during apogee boost.

The apogee burn is accomplished with two nearly equal parts using bipropellant apogee thrusters. After reorientation to orbit normal, the platform is inertially despun and the gyrostabilization mode is established. The remaining deployments are then performed sequentially. The telescoping solar panel is lowered to increase the available power and to expose a mirrored thermal radiator needed for on-orbit heat rejection. The lowered panel also provides the means for precision dynamic balancing using its three positioning mechanisms to alter its tilt with respect to the spacecraft spin axis. Subsequent deployments of C and K band reflectors and global horns bring the spacecraft to its final configuration. On-station operation begins after beam pointing adjustments are made using the trim mechanisms on the C band reflectors, the positioning mechanisms on the K band spot antennas, and the global horn assembly. All of the deployments are initiated by release of launch locks that are activated by redundant scrub devices. The omni T and C and the large C band reflector antennas are deployed using simple spring viscous damper mechanisms that drive against hard stops to provide repeatable pointing performance.

COMMUNICATIONS PAYLOAD

The IntelSat VI communications system provides two hemispherical, four zone, and two global beams at C band and two spot beams at K band. The C band reflectors consist of a 2.0 meter dish at 6 GHz and a 3.2 meter dish at 4 GHz. The coverage patterns are shown in Figure 3. A simplified block diagram of the communication system is shown

TABLE 1. SPACECRAFT DESIGN AND PERFORMANCE CHARACTERISTICS SUMMARY

Size, mm								
Spacecraft diameter (maximum)	3639							
Solar drum height								
Forward (fixed)	2159							
Aft (deployable)	3970							
Overall height								
In Ariane 4 (including adapter)	6414							
In STS (including PCM)	8251							
In transfer orbit (arm deployed)	7691							
On station	11831							
Mass, kg								
	STS				Ariane			
Launch vehicle payload	13695				3743			
Separated mass	12369				3683			
On station, BOL	2251				2231			
Available spacecraft dry mass	1792				1792			
Contingency	82				87			
Spacecraft dry mass	1719				1705			
Stabilization								
Transfer orbit	Stabil. spinner							
On station	Gyrostat							
Stationkeeping performance (limit)								
Longitude	±0.10°							
Latitude	±0.10°							
Spacecraft reliability								
First 2 months	0.937							
7 year mission	0.893							
10 year mission	0.674							
Communications subsystem								
	Global		Horn		Zona		Spot	
Transmit frequency, GHz	4.2		4		4		4	
EIRP, dBW	Ch. 9 (9.12)		25.0		29.0		28.8	
	On		26.9		31.5		31.7	
Receive frequency, GHz	6		6		6		6	
Receive G/T, dB/K	-11.8		-8.3		+1.6		-5.7	
Number of channels								
36 MHz	6		2		1		1	
41 MHz	2							
72 MHz			10		3		3	
77 MHz					1		1	
150 MHz							2	
Telemetry subsystem								
Modes								
PCM/PSK normal and dwell								
Ranging								
PCM on STS								
Channels								
	Despun		Spun					
Silent	423		134					
Analog	253		114					
Serial	6		4					
Capacity	763		256					
EIRP	4.2 dBW transfer orbit, 2.2 dBW on station							
Frequency	3947.5 to 3952.5 MHz							
Command subsystem								
Format								
PCM-RZ tones								
Commands								
	Despun		Spun					
Pulse	626		168					
Serial	19		2					
Capacity	763		256					
Receive flux density range	90 to -65 dBW/m ²							
Frequency	6172 to 6178 MHz							

TABLE 1 (Continued)

Attitude control subsystem						
Antenna pointing						
Backup modes						
Worst case pointing error (deg 3 σ)						
Earth sun references						
Beacon tracker subsystem ground torque						
C Band						
K Band						
N-S						
E-W						
Yaw						
ADCS mode, steady state	0.081	0.066	0.087	0.030	0.077	0.085
ADCS mode, maneuver	0.100	0.059	0.108	0.103	0.071	0.106
BTS mode, steady state	0.038	0.036	0.087	0.089	0.048	0.085
BTS mode, maneuver	0.085	0.056	0.108	0.103	0.068	0.106
Design	0.12	0.12	0.15	0.12	0.12	0.15
Propulsion subsystem						
Number of tanks, redundancy	3 propellant (dual half-systems), 2 helium					
System construction	Welded titanium/stainless					
Propellant	Oxidizer: nitrogen tetroxide; fuel: monomethyl hydrazine					
Propellant load						
STS launch, 10 yr	2367 kg (baseline), 2074 kg (growth)					
Axial launch, 10 yr	1326 kg (baseline), 2122 kg (growth)					
Tank capacity	3861 kg (100% full)					
Number of thrusters	4 axial (490 N, 22 N); 4 radial (22 N)					
Electrical power subsystem						
System	Dual pre-regulated buses with tap limiters					
Solar cells	High efficiency K7 (deployed panel), K43-A (body); 2 x 6 cm nominal; welded; 200 mm thick					
Array orientation power (10 yr)						
Winter solstice	2047 W					
Equinox	2154 W					
Panel margin	12.2%					
Battery system	Nickel-hydrogen batteries (two)					
Capacity	3017 Whr					
Depth of discharge, 10 yr	64.7% with one cell failed per battery					
Thermal control	Passive heat rejection radially via thin quartz mirror radiator (redundant heaters where needed)					
Structure	Aluminum honeycomb monocoque central structure with strut stabilization in outer load path					

in Figure 4. The Intelsat VI system utilizes the same frequency channels in the 6/4 GHz band six-fold. This efficient use of the allocated frequency spectrum is achieved by making the two spatially isolated beam beams orthogonal in polarization to the four spatially isolated zone beams. The beam and zone beams can thus share the same channels. Similarly, the two spot beams and the two global beams are made opposite in polarization to one another to permit them to share the same channels in their respective frequency bands.

The onboard receivers convert all the uplink RF signals to a common 4 GHz IF. The channel dropping input multiplexer then separates the incoming signal into the channels in the frequency scheme shown in Figure 5. Here, the power levels of the signals are equalized and entered into the interconnection switch matrices. One distinctive feature of the Intelsat VI spacecraft is its high degree of interconnectivity. Channels 5-6, 7-8, and 9 may be interconnected in a static way through a matrix of transfer switches. Channels 1-2 and 3-4, however, may be interconnected in a burst mode through the microwave switch matrix (MSM) at a 2-ms repetition rate for SS-TDMA operation. As a backup to the dynamic mode, a static bypass switch matrix is provided for channels 1-2 and 3-4.

The high power amplifiers are a mixture of traveling wave tubes and solid state power amplifiers. For reliability, all the C Band HPAs are configured three for two redundant and the K Band TWTs are four for two redundant. After amplification, the channels are recombined in the continuous channel output multiplexers in front of the transmit antennas.

During the initial phase of in-orbit operation, it is planned to place the Intelsat VI spacecraft in the vicinity of the existing Intelsat VVA spacecraft and gradually take over the operation of the Intelsat VVA traffic. Thus, the Intelsat VI spacecraft has a switchable Intelsat V/VA compatibility mode that is accomplished by combining pairs of zone beams to simulate the coverage of the Intelsat V/VA east and west hemi-beams. This can be accomplished by combining the two signals in a hybrid coupler on a channel by channel basis.

Performance of the communication system is shown in Table 1.

CONCLUSIONS

Multiple frequency reuse is realized at C-band by providing highly isolated antenna beams. Four spatially isolated zone beams overlap two oppositely polarized hemi-beams in the frequency spec-

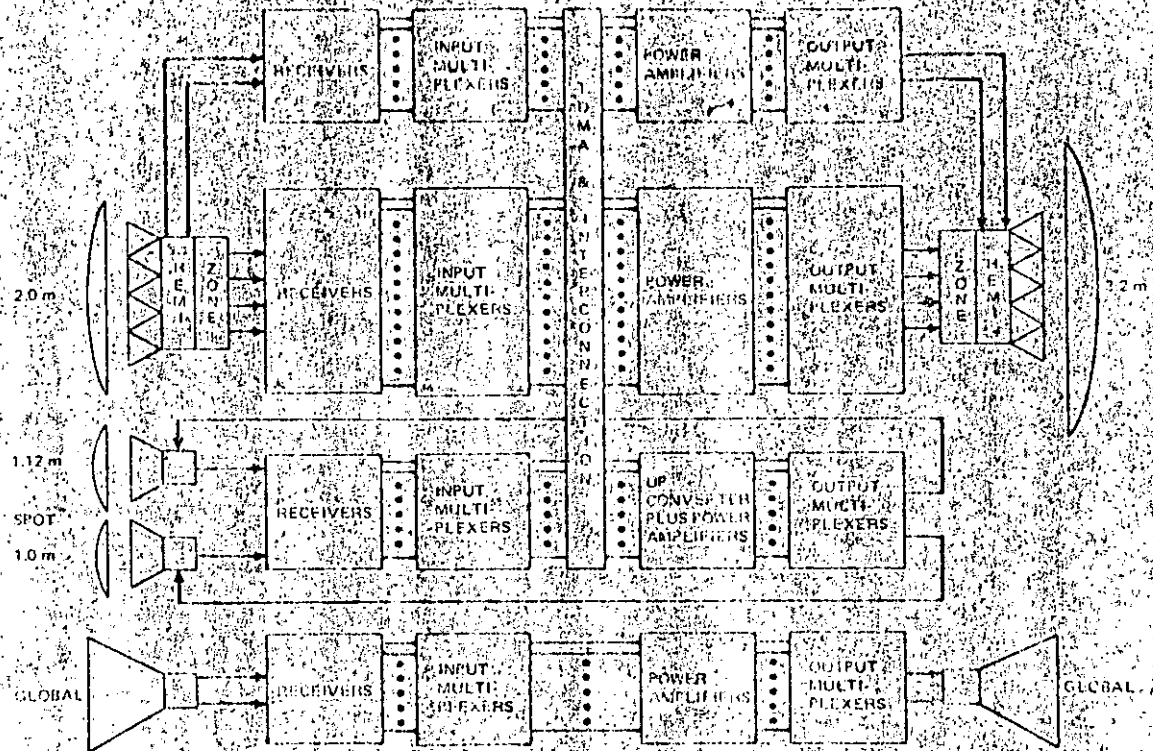


FIGURE 4: COMMUNICATIONS SUBSYSTEM SIMPLIFIED BLOCK DIAGRAM

turn while two oppositely polarized global horns cover the earth's disc in the upper channels, thus permitting a six-way usage of the same frequency spectrum. The spatial and polarization isolations are each approximately 30 dB in the transmit and receive coverages to provide good C/I ratios. The beam and zone antennas consist of separate transmit and receive offset feed reflector antennas, each using a multiple horn feed array. The horns are connected to a feed network that provides the proper excitation for four zones and two hemispheres simultaneously. The feed network consists of TEM squareax transmission lines and couplers that are precisely tuned to give the desired phase and amplitude at each horn. The elements of the array are Potter horns excited in the TE_{11} and TM_{11} modes to give symmetrical element patterns to ensure good axial ratio for circular polarization. Polarization is determined by probes that are spaced 90° apart in a circular waveguide polarization launcher. The probes are fed by a hybrid splitter that provides the necessary 90° phase shift for C.P.

Because each spacecraft is required to be capable of operating in any of the three ocean regions, switching is required to change the excitation of the elements while in orbit. Coverage of the Atlantic, the Pacific, and the Indian Ocean regions is provided for by three different layers of feed networks. The three networks may be chosen by command. The changing of feed layers involves actuating one mainline switch to the receiver or transmitter, and approximately 90 other switches that connect the horn elements to the proper layer of squareax. All the switches are mechanically controlled by a lever arm and

activated simultaneously by a single mechanism. The change in ocean regions involves only the change in zone coverage. The hemispherical coverage remains the same for all three regions.

C band global coverage is provided by two horns, one for transmit and one for receive. Each horn is fed by an orthomode tee that is capable of simultaneous operation at two oppositely circular polarizations. These two communications C band horns are mounted in a cluster of five horns. The other horns are a K band beacon transmitting horn and two 4 GHz telemetry horns. The cluster of five horns is steerable over a $\pm 2^\circ$ range to compensate for offset biases in the beam platform.

The C band antennas consist of separate east spot and west spot single feed reflectors. The former has a circular coverage of 1.54° and the latter is an ellipse with a $1.64^\circ \times 3.04^\circ$ degree beam. Both antennas are mechanically steerable to any coverage on the earth's disc. Both are linearly polarized and are orthogonal to each other for good isolation. Because of the smaller percentage of band separation, the transmission of 11 GHz and reception of 14 GHz functions are performed on the same antenna.

SS-TDMA

On board, SS-TDMA system is featured in channels 1-2 and 3-4. Two identical switching units are provided for interconnecting the Beam East, Beam West, and the four zone beams. Switching is activated by a program stored on board the satellite. Each switching unit consists of a 10×6 dynamic microwave switch matrix (DMS) with associated digital input logic, an input ring

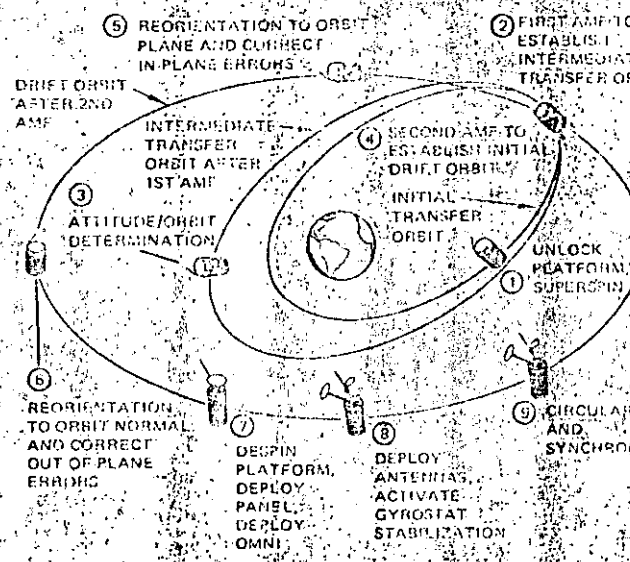
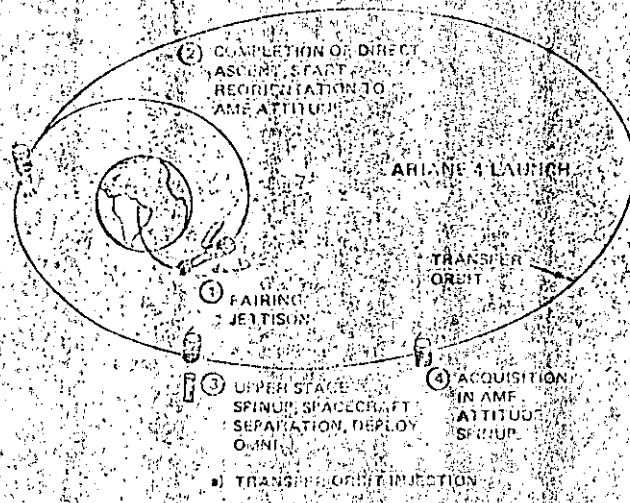
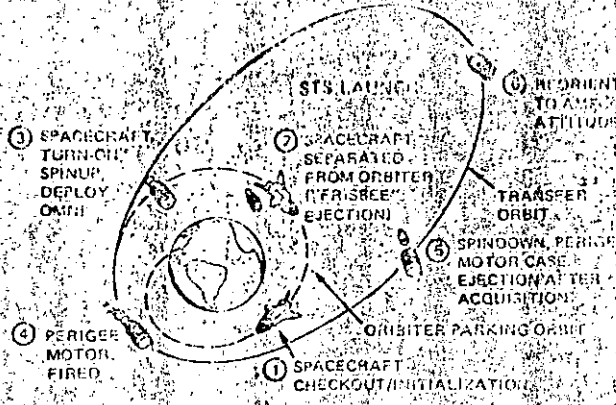


FIGURE 2. MISSION SUMMARY

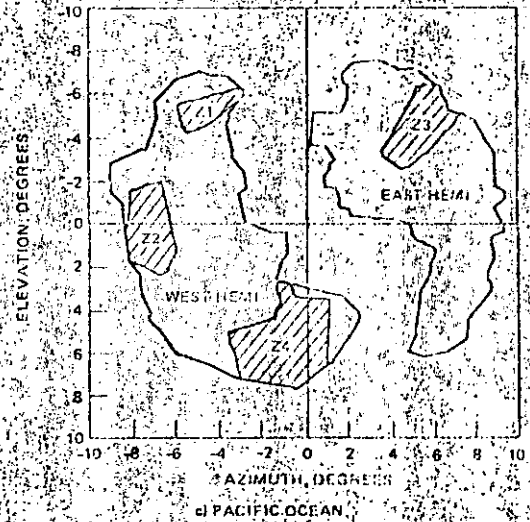
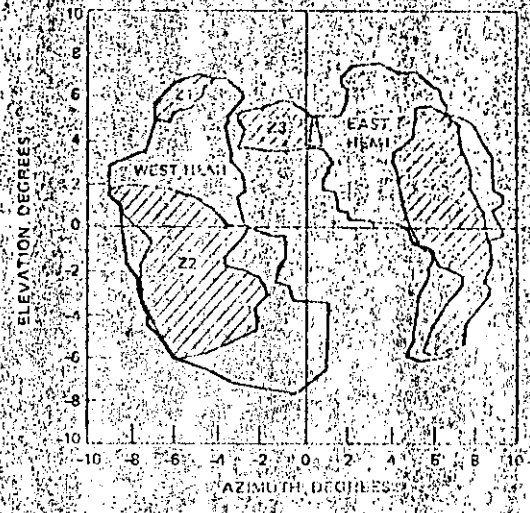
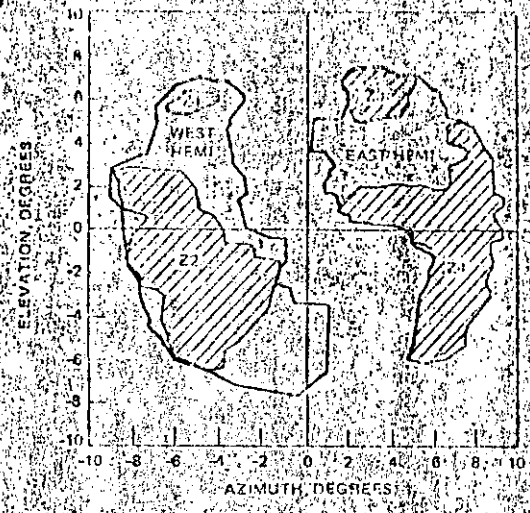


FIGURE 3. HEMISPHERIC AND ZONE COMPOSITE COVERAGE REQUIREMENTS

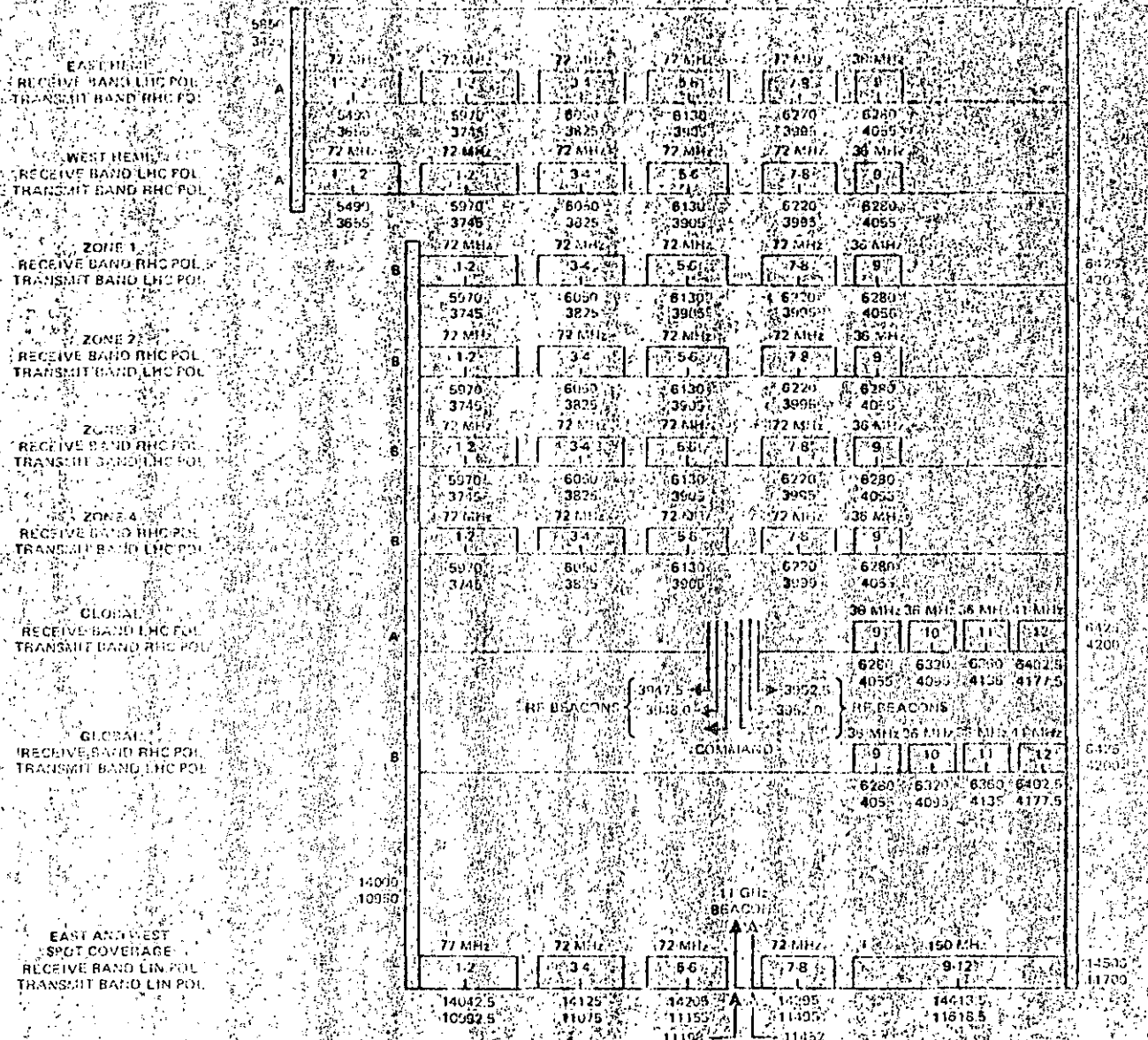


FIGURE 5. TRANSPONDER CENTER FREQUENCIES, BANDWIDTHS AND POLARIZATION.

redundancy network, and two distribution and control units (DCU) with internally redundant memories and a static bypass switch. The functional block diagram of the SS-TDMA system is shown in Figure 6 and the interface signals are shown in Table 2. Both units share a common active timing source for phase coherence between the switching time of the two TDMA transponder banks. Each unit can access one of three identical timing sources through ground commands.

Operationally, each switching unit establishes interconnections among the six active input rows and six output columns. The interconnection pattern for each switch state and the duration of the state are contained in the data stored in three redundant DCU memories. The DCU sequentially cycles through the memory over a 2 ms period and provides the control signals for each switch state

to the MSM. The memory contains up to 64 switch states, thus providing flexibility in network traffic routing.

The dynamic switch matrix uses a coupled crossbar architecture with integrated switch elements at each junction to allow for a combination of interconnecting modes. In the dynamic mode, an output port is connected to various input ports in a cyclical pattern with from 2 to 64 states over a 2 ms period. In the semistatic mode, an output remains unchanged over the 2 ms, and in the broadcast mode, an input port is connected to more than one and up to six output ports. The 2 ms switching frame is divided into 1808 equal frame units of 1.059 usec each, and the minimum duration of each switch state is 4 frame units or 4.236 usec. The maximum switch state is 2 ms in the semistatic mode.

TABLE 3. DCU FUNCTIONAL PERFORMANCE

Switch input size	10 inputs, 6 outputs
Minimum switch state duration	4.236 μ s (1 frame unit)
Maximum switch state duration	2 ms (full frame)
Switch state duration increments	1.059 μ s (1 frame unit)
Number of switch states per memory	64
Number of memories	13
Length of data word	48 bits

BUS SYSTEM DESIGN

The command system utilizes a biconic antenna for reception of commands during the transfer orbit as well as during on-station operations. The command signal consists of three tones that represent 1, 0, or execute, which are frequency modulated into one of two possible carriers. The command RF signal is demodulated in redundant receivers and processed in redundant command processor units (CPU). The commands are then sent out to remote decoder units (RDU) and routed to their appropriate designations. The spacecraft contains four pairs of RDUs; each has the capability of 256 bilateral or 16 serial commands.

The telemetry system collects sampled serial or binned conditioned and nonconditioned telemetry data at the eight redundant remote telemetry units (RTU). The central telemetry unit (CTU) serializes the TM data into a dwell data subcarrier and a nominal data subcarrier. These two subcarriers biphasic modulate each of two TM carriers in the telemetry transmitters. During transfer orbit, the TM is transmitted via a 10 watt TWT and a biconic antenna. While on station, the transmission is through a pair of gnomon horns with a low power transmitter.

The power subsystem is a centrally preregulated, two-independent bus system controlled under steady state conditions between 28 and 30 volts. The preregulated bus reduces voltage stress on units and permits the use of series type regulators for most loads. The 28 volt minimum bus voltage is maintained by the battery discharge controller; the 30 volt maximum steady state voltage is controlled by shunt limiters attached to tap points within the series length of the solar cell strings. In sunlight, the solar panel furnishes current directly at bus voltage. During eclipse, the battery automatically supplies current through a battery discharge controller that translates the battery output from an average of 38 volts to the 28 volt bus. Battery charge current is passively controlled by switching a selected number of solar cell strings from the main 28 volt array directly to the battery. Nickel hydrogen batteries are used. K-7 solar cells are used on the deployable array and K-4-3/4 cells are used on the fixed array.

The liquid bipropellant system (LPS) uses the hypergolic propellants nitrogen tetroxide (N_2O_4)

and monomethyl-hydrazine (MMH). Four 22 N radial thrusters provide for east-west station-keeping and spin-up/spin-down control. At the aft end of the spacecraft are two 22 N axial thrusters for north-south station-keeping and attitude control, and two 490 N axial thrusters for apogee boost and reorientation maneuvers.

Sensors for spin axis attitude determination throughout the mission are provided by a single set of rotor-mounted sun and earth sensors. Digital time interval measurements, based on real time sensor pulse output data, are processed onboard for calculation of spin axis attitude. Sensor data are also transmitted to the ground to be monitored. Measurement resolution of 0.01% at the nominal 30 rpm spin rate allows determination of attitude to 0.02% accuracy.

Control of the spin axis attitude, rotor spin rate, and spacecraft orbit is accomplished by pulsed or continuous firing of selected spacecraft thrusters. Spin rate and orbit control are normally implemented by onboard execution of a ground-programmed maneuver sequence. This eliminates the requirements for real time ground control of the spacecraft to perform orbit or attitude adjustments, because maneuvers can be programmed up to 7 days in advance. The primary mode for attitude control utilizes algorithms contained in the attitude control electronics (ACE). The ground-programmed maneuvers are a backup to this autonomous system.

Nutation stabilization is provided by two automatic control loops that damp transient nutation and provide asymptotic stabilization with substantial margins over worst case fuel slosh. Nutation sensing for the controllers is provided by accelerometers.

The beacon tracker subsystem (BTS) nominally performs initial alignment of the C band hemi/zone antennas with respect to the design compartment, and precision closed loop pointing of their beams. In addition, this subsystem provides backup capability for despun control, nutation control, and command receive functions.

Sun and difference azimuth and elevation pointing information is generated by receiving and processing a beacon signal transmitted from a ground station. This signal is received by dielectrically loaded horns located interstitially to the communications horns of the transmit and receive hemi/zone feed arrays.

Azimuth and elevation pointing of the transmit reflector and elevation of the receive reflector are accomplished using electrically redundant stepper motors with dual windings. The motors are controlled by the track receiver through the stepper motor drive unit. Azimuth pointing of the receive reflector is nominally performed through azimuth control of the platform.

Transmit and receive reflectors operate independently and can lock-in on selected beacon sites in any one of the three ocean regions. An offset capability is employed to optimize C band coverage patterns for any particular orbit situation.

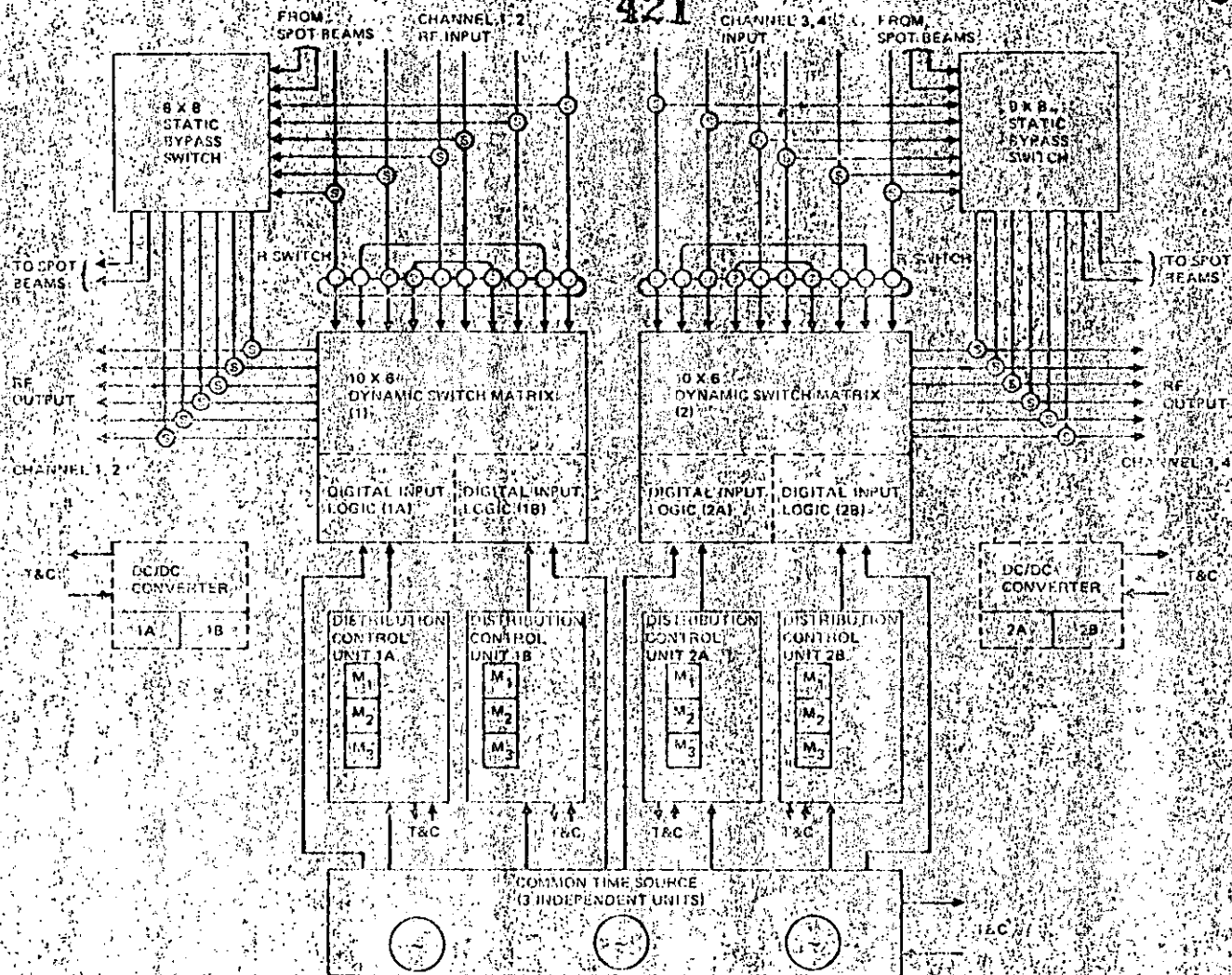


FIGURE 6. TDMA SWITCHING UNIT FUNCTIONAL BLOCK DIAGRAM.

TABLE 2. INTERFACE SIGNALS SUMMARY.

Signal Description	Number of Lines	Frequency
a) Between Time Source and LCU		
DCU frame limit clock	3*	934 kHz
Switch frame	3*	500 Hz
Switch master frame	3*	500-8192 Hz
b) Between DCU and MSM Input Logic		
Serial control data	1	7.552 Mbps
Serial transfer clock	1	7.552 MHz
Switch-over command	1	
2 bit time source select	2	
c) Between Time Source and MSM Input Logic		
Frame limit timing	3*	0.944 MHz

*One line from each time source.

Switchover to a new traffic pattern can be activated at a fixed location in the master frame, which consists of a sequence of 8192 frames.

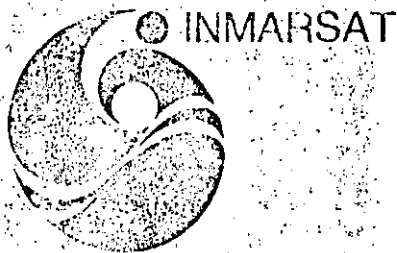
Performance of the dynamic switch is shown in Table 3. Stringent design requirements are imposed on the switch elements, amplifiers, and transmission lines to provide no more than 0.2 dB amplitude variations between interconnections. The phase offset between the start of frame of channel 1-2 and 3-4 switches is less than 60 ns. The rise and fall times of the RF signal at the switchings are better than 50 ns. The reference oscillators are designed to attain maximum stability. The long term average drift over any 72 consecutive day period will be less than 1×10^{-11} , and the short term jitter is better than 1×10^{-15} when measured in a 200 ms sampling time. The turn-on and turn-off timing jitter, as well as the variations between transition times between any two paths, is better than 20 ns.

422

THE CHANGING OF THE GUARD

I N M A R S A T

The Changing of the Guard



An orderly transition has begun from today's Marisat system to tomorrow's Inmarsat system.

Within the Comsat organization, responsibility for maritime satellite communications services, including Marisat services during the balance of 1981, has been shifted from Comsat General to a new office in the parent company, Comsat. The new office is Maritime Services, part of the World Systems Division of Comsat.

(Comsat General TeleSystems, Inc., a separate subsidiary, will continue to have responsibility for the sale, lease, and maintenance of shipboard terminal equipment, independent of Maritime Services' responsibility for communications services.)

Marifacts, which has a circulation of more than 4,000, will be published by Comsat Maritime Services. This is the first of three issues during the 1981 transition year to be issued under the new company organization; the cover of this issue with the Comsat corporate identification reflects this changeover.

Marifacts will report during the year on the latest developments of the emerging Inmarsat system. The following article summarizes these developments to date.

A Beginning

Inmarsat, the International Maritime Satellite Organization, came into existence on July 16, 1979. On that date, 26 member states and signatories signed its Convention and Operating Agreement.

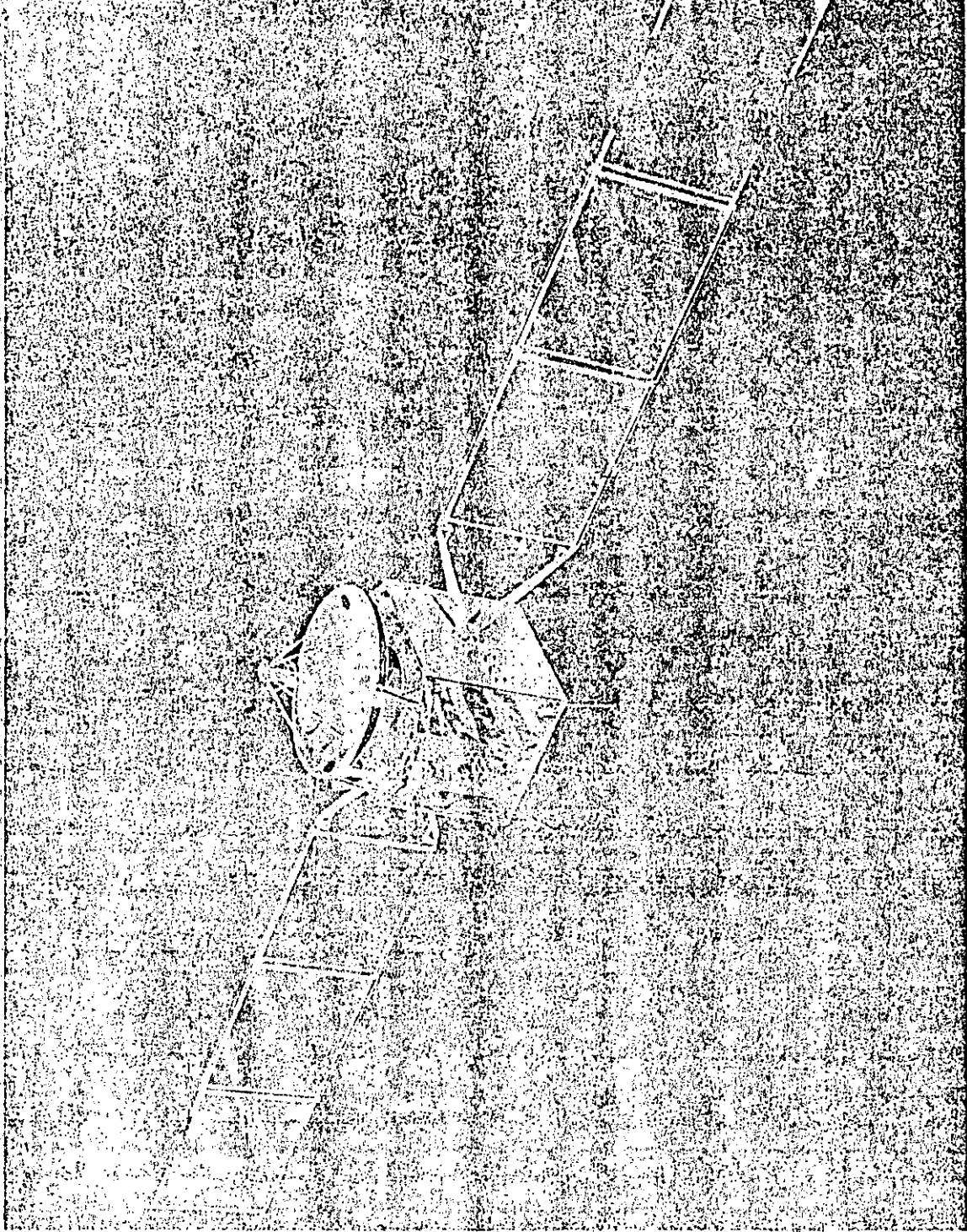
Patterned along the line of Intelsat, the multinational International Telecommunications Satellite Organization, Inmarsat membership has grown to 35 countries today.

Inmarsat's governing body is a Council. The largest single investment share in Inmarsat is held by the United States, followed by the Soviet Union, the United Kingdom, Norway and Japan (see accompanying list of Inmarsat members). As a result of a Congressional Amendment to the Communications Satellite Act of 1962, Comsat represents the United States on the Council.

The headquarters of Inmarsat are in London, England. Its day-to-day activities are carried out by a Directorate, headed by Director General Olof Lundberg, formerly of the Swedish Telecommunications Administration. Mr. A. R. K. Al-Ghunaim, Under Secretary of the Ministry of Communications, Kuwait, is the current Chairman of the Council.

Continuity Assured

One of the prime objectives of the Council in its transition planning for



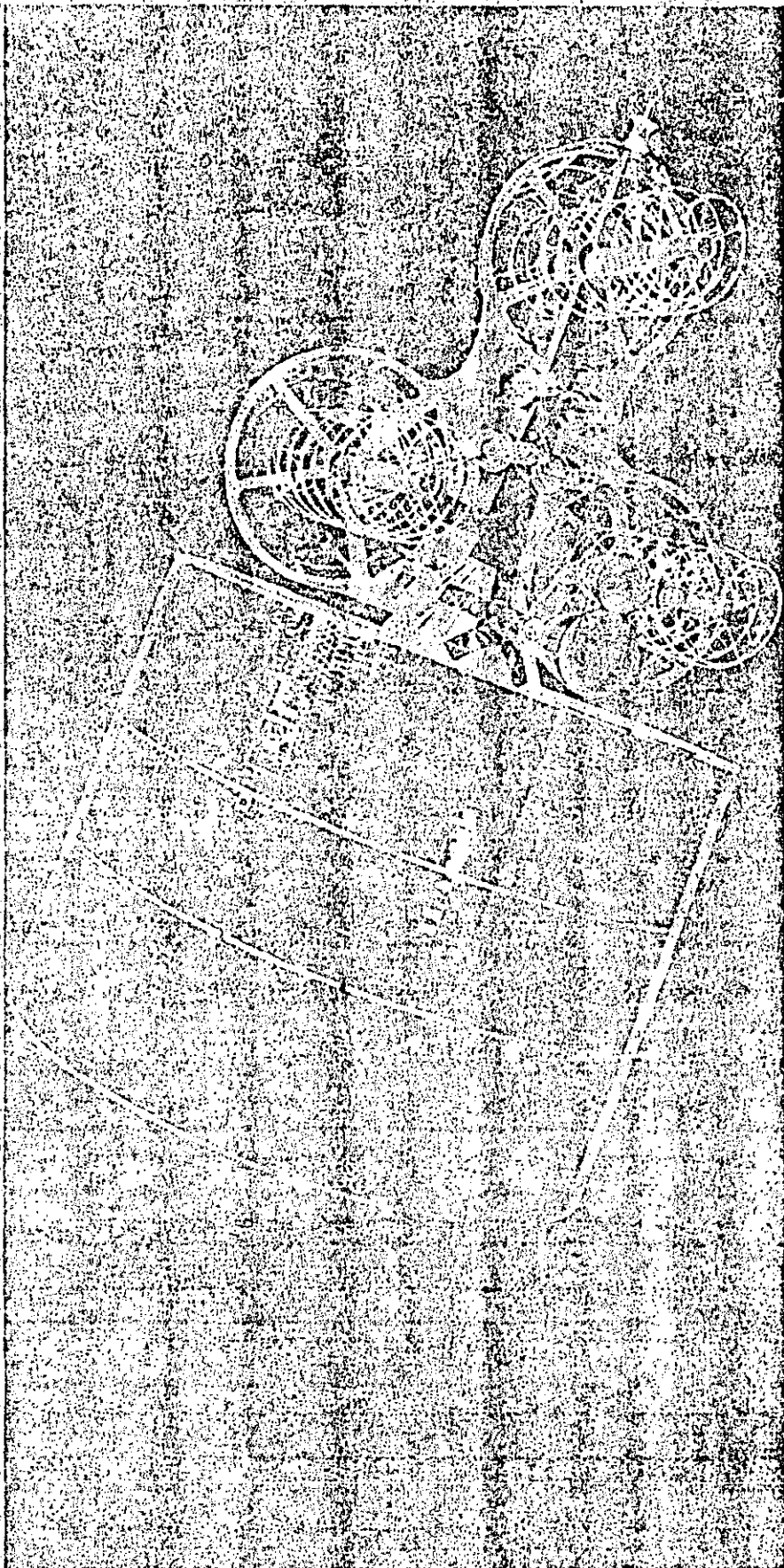
Marecs.

the Inmarsat system has been to ensure continuity of service to users of the present Marisat system, now in its fifth year of successful operation. For example, all ship terminals using today's Marisat system will be able to use tomorrow's Inmarsat system.

In addition, new satellites, with higher capacity, will be placed in operation by Inmarsat. The initial system will utilize Marecs satellites from the European Space Agency, Intelsat-V satellites each containing a Maritime Communications Subsystem as well as existing Marisat satellite capacity.

The three existing shore stations—two in the United States and one in Japan—will continue to operate in the Inmarsat system. Inmarsat estimates that 12 to 13 shore station antennas are expected to be in operation by the end of next year.

Continued on next page



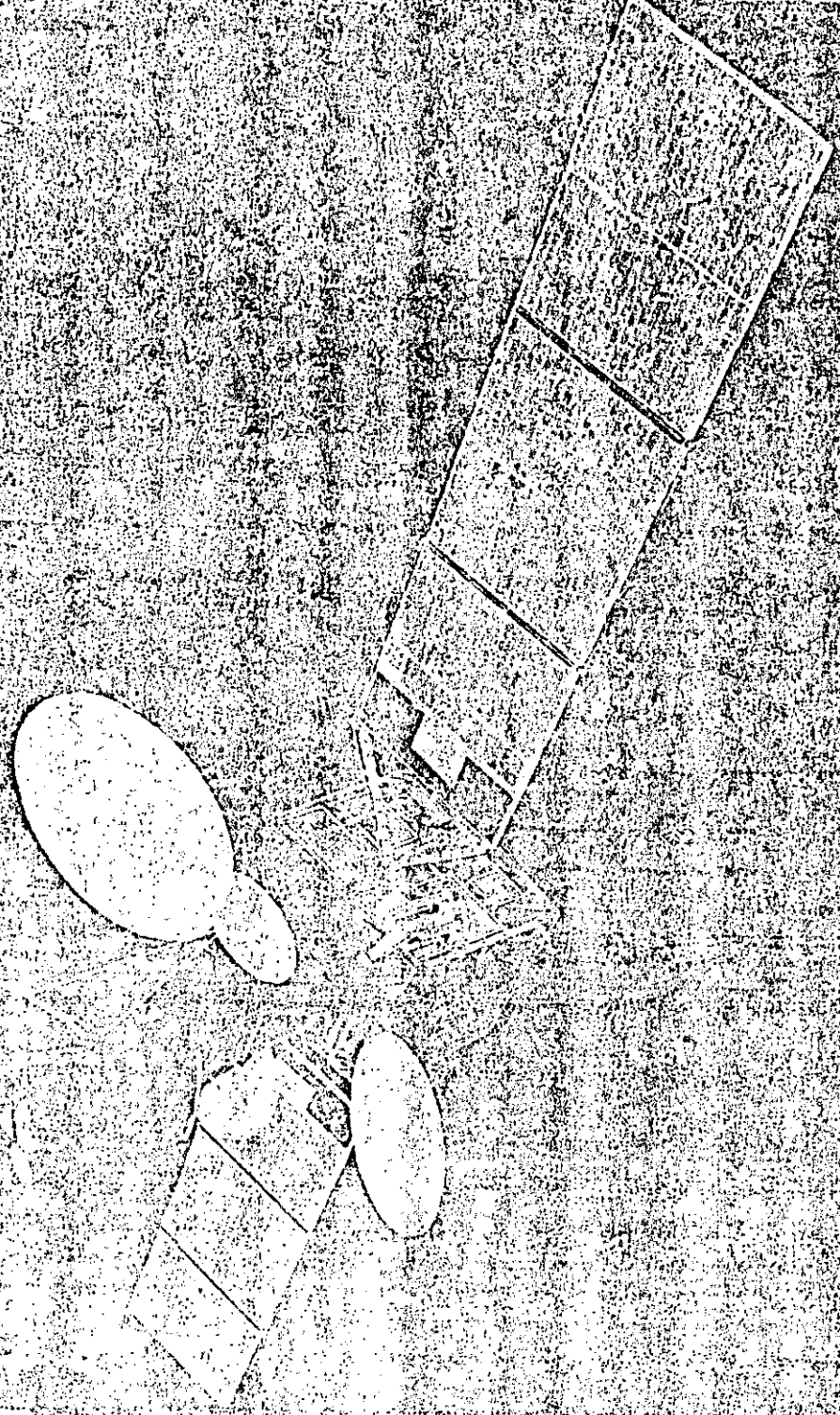
Marisat.

including new stations in Japan, Europe, Asia and the Mid-East. For the shipping and offshore industries, this will mean direct access to new areas of the world, and improved service because of shorter and less costly terrestrial links.

Services

Marisat has introduced significant improvements in communications with ships at sea. The establishment of Inmarsat, and the commitment to its development by the major seafaring nations of the world, means continued expansion and improvement in these communications. Present Marisat services include:

- Telex—standard 66 wpm telex service is fully interconnected with the international switched network.
- Telephone—calls which are now operator-assisted will be upgraded to automatic direct dial calls in the ship-to-United States direction by mid-1981. In the shore-to-ship direction, calls via the two U.S. shore stations will be operator-assisted until sometime in 1982.
- Voiceband data—voice circuits can be used for the transmission and reception of voice grade data at rates of 2400 bps and greater depending on arrangements. Data transmissions, as well as analog or digital facsimile transmissions, can be interconnected with public networks worldwide.
- 56 kbps — tariffs have been filed, effective mid-1981, for the provision of 56 kbps ser-



Intelsat V.

vice, between ships and the United States via Marisat. This new service is expected to be of prime interest to operators of seismic exploration ships. Inmarsat is considering offering the same or similar wide-band service via the Inmarsat system next year.

Continued Growth

Today, there are more than 650 ships and offshore facilities equipped with terminals for operation with the Marisat system. The number of terminals commissioned for operation with maritime satellites is expected to grow steadily, to an

estimated 750 by the end of 1981, to 2000 under Inmarsat by 1985.

A smooth transition, new services and expanded capacity, steadily increasing numbers of terminals and volumes of traffic, all characterize "the changing of the guard" from Marisat to the emerging Inmarsat system. □

System Compatible Shipboard Terminals

One of the prime goals in the transition from Marisat to Inmarsat has been to ensure continuity and quality of service. Thus, Inmarsat decided early that all models of shipboard terminals type-accepted for use in the Marisat system will be accepted for use in the Inmarsat system.

A number of manufacturers now supply terminals which have been type-accepted for use in Marisat, and others have applications on file for type acceptance. As a convenience to the maritime community, we are pleased to list below the companies currently providing type-accepted terminals, which also will be compatible with the Inmarsat system next year.

ANRITSU

Anritsu Electric Co. Ltd.
Radio Products Division
10-27, Minamiazabu 5-chome
Minato-Ku, Tokyo 106 Japan
(446) 1111

COMSAT GENERAL

TeleSystems, Inc.
2721 Prosperity Avenue
Fairfax, Virginia 22031
(702) 698-4300

SCIENTIFIC ATLANTA

Scientific Atlanta
3845 Pleasantdale Road
Atlanta, Georgia 30340
(404) 449-2000

SIEMENS

Siemens
51 Str.
Munchen
Federal Republic of Germany
(089) 722-25290

JAPAN RADIO

Japan Radio Co., Ltd.
No. 5-1-1
Shinorenjaku Mitaka-Shi
Tokyo, Japan
(0422) 44-9111

MAGNAVOX

Magnavox
Marine Systems Operation
2829 Maricopa Street
Torrence, California 90503
(213) 328-0770

MARCONI

Marconi
Marrable House
Great Badow
Chelmsford, England CM27 0QW
(0245) 73331

TOSHIBA

Toshiba America, Inc.
OEM Division
2900 MacArthur Blvd.
Northbrook, Illinois 60062
(312) 564-5140

UNITED MARINE ELECTRONICS

A/S Elektrisk Bureau
Division of UME
P.O. Box 98 Nesbru
Norway
(011) 472-788060



Inmarsat Members

Country	Investment Shares Held
United States	23,37543
USSR (and Byelorussian SSR, Ukrainian SSR)	14,37543
United Kingdom	9,89631
Norway	7,89217
Japan	7,00267
Italy	3,35893
France	2,88698
Federal Republic of Germany	2,88698
Greece	2,88698
Netherlands	2,88698
Canada	2,61448
Kuwait	2,01416
Spain	2,01416
Sweden	1,87854
Denmark	1,67854
Australia	1,67854
India	1,67854
Brazil	1,67854
Poland	1,67854
Singapore	1,67854
People's Republic of China	1,23728
Belgium	0,60425
Finland	0,60425
Argentina	0,60425
New Zealand	0,60295
Bulgaria	0,27218
Portugal	0,20620
Algeria	0,05000
Egypt	0,05000
Iraq	0,05000
Liberia	0,05000
Oman	0,05000
Chile	0,05000
Philippines	0,05000
	100,00000

Inmarsat is in the process of establishing standard specifications for ship terminals in the future, as well as type approval and commissioning procedures that will apply later as Inmarsat assumes system operations.

428

Shore Stations, Existing and Planned

Shown below is a list of shore stations now in service, or planned to be in operation during 1982/1983. Data for this list were provided Marifacts by the Inmarsat Directorate's Office. The information is current as of April 1981.

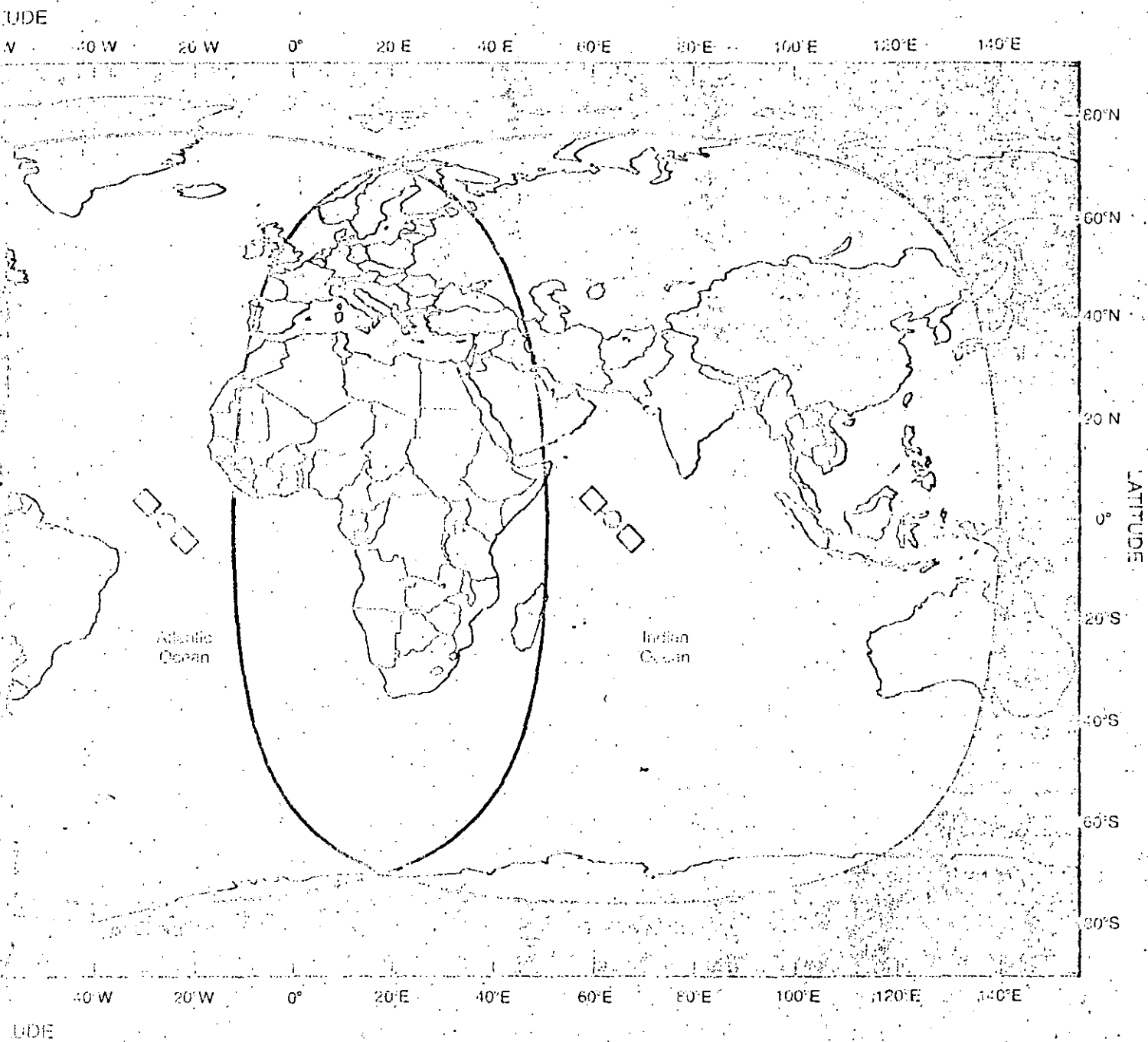
SHORE STATION	OPERATION DATE	OCEAN REGION
Argentina, Mar Del Plata	1983	Atlantic
Brazil, Tongva	1983	Atlantic
Egypt, Meadi	1983	Reding
France, Pleumeur Bodou	1982	Atlantic
Greece, Thermopylae	1982-83	Atlantic
Hong Kong	1983	Pacific
Italy, Frecino	1982	Atlantic
Japan, Ibaraki	1982	Pacific
Japan, Yamaguchi	Operating	Indian
Kuwait, Umm-Al-Aish	1982	Atlantic
Norway, Eik—with Denmark, Finland & Sweden	1982	Indian or Atlantic
Oman, Muscat-Wattaya	1983	Atlantic and Indian
People's Republic of China, Beijing	Pending	Indian and Pacific
Singapore	1982	Pacific
United Kingdom, Goonhilly	1982	Atlantic
USA, California	Operating	Pacific
USA, Connecticut	Operating	Atlantic
USSR, Nakhodka	1983	Pacific
USSR, Odessa	1982	Atlantic

For each of the three major ocean areas—Atlantic, Pacific and Indian—a Network Coordination Station (NCS) will govern the accessing of the satellite serving that ocean. All shore stations serving that ocean area will be linked with an NCS. The stations also will be connected to a variety of telecommunications carriers' networks for distribution of traffic between marine units and points on shore.

One of today's three operating shore stations is located at Southbury, Connecticut, about 60 miles northeast of New York City.

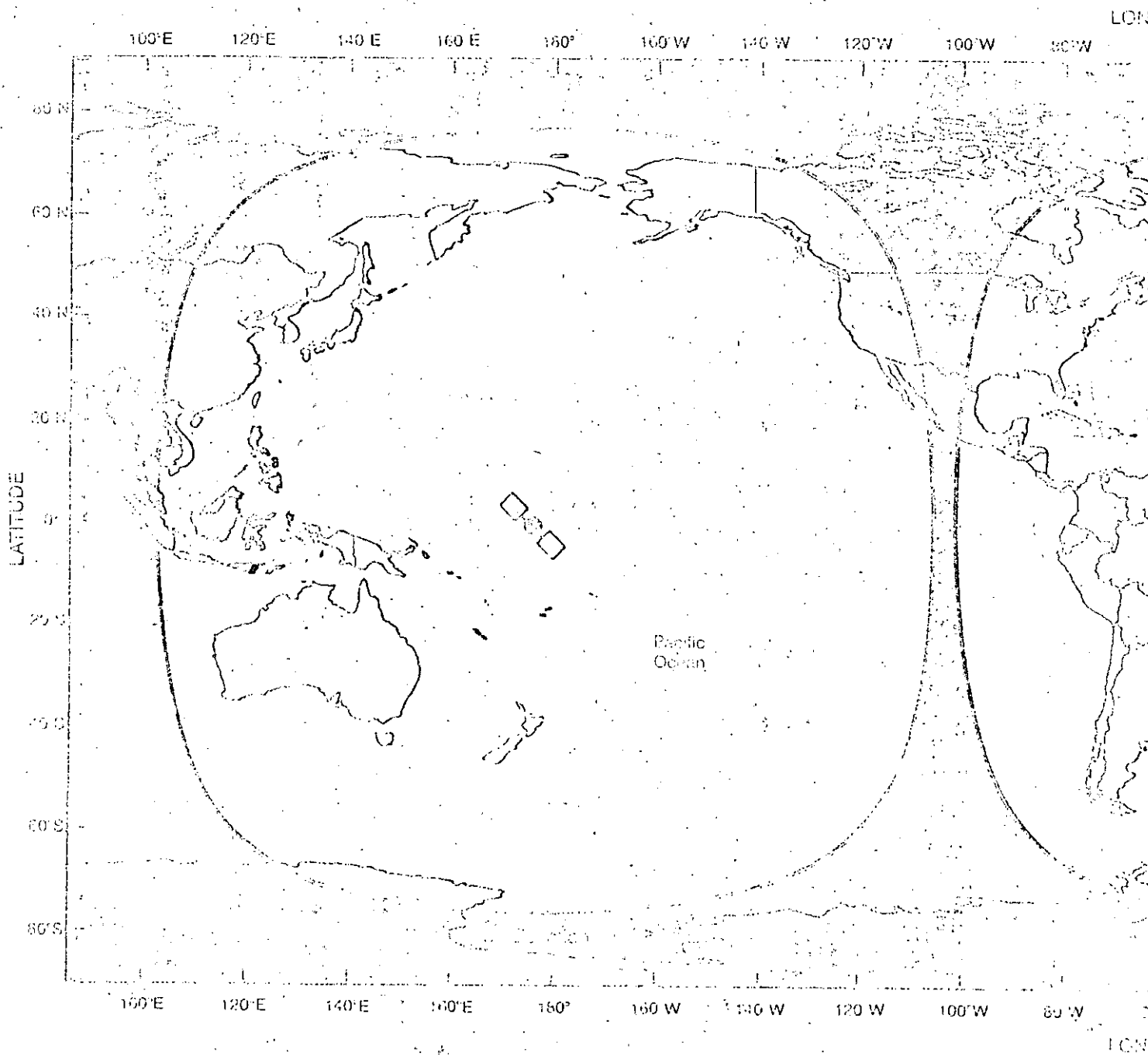
Comsat System

429



COMISAT Maritime Services

The Initial In



INMARSAT Singapore coast earth station

Richard K.T. FONG

Telecoms. Comcenter, 31 Exeter Road, Singapore 0923, Republic of Singapore

K. KAZUI

NEC Corporation, Y-5681, 4035, Ikebe-cho, Midori-ku, Yokohama 226, Japan

As of May 1983, seven INMARSAT coast earth stations (CESs) have been providing a commercial global maritime communications service. Since its development, the earth station design has been refined to provide a standard design suitable for the first generation of the INMARSAT system.

The intent of this paper is to present the typical performance of the Singapore CES which incorporates the latest equipment design. The CES system including the radio frequency (RF) and access control and signalling (ACS) subsystems are described with emphasis on the key technical features to achieve high performance.

Key features include a C- and L-dual band Cassegrain antenna with associated radio equipment and a central processor controlled digital exchange equipment which provides a flexible interface with the existing terrestrial networks.

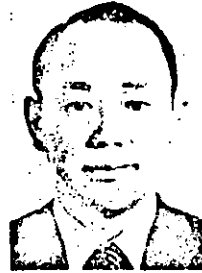
Keywords: INMARSAT, dual band antenna, access control and signalling equipment, central processor control



Richard Fong Keng Thong has been involved in satellite communications since he worked as project manager responsible for the construction of the Singapore Indian Ocean Intelsat aerial in 1969 and again for the Pacific Ocean aerial five years later. It was therefore inevitable that he should also take charge of building the coast earth station as well. As Divisional Manager for Engineering Operations he is now responsible for all international telecommunications from the technical

point of view, including submarine cable and microwave.

Mr. Fong's position represents a logical development in a career devoted to Telecoms since he graduated in Engineering from the University of Malaya in Kuala Lumpur in 1964. This was followed by a Masters degree at Chicago Institute of Technology before he joined Telecoms. Apart from an eight-month spell in 1975-76 as a research engineer in a remote sensing lab at Nasa's Space Technology Centre in Laurence, Kansas, he has been at Telecoms ever since.



Katsuhiko Kozui was educated at the Hokkaido University, where he received a B.S. degree in Electrical Engineering in 1961. Since joining NEC Corporation in the same year, he has been involved in the development and applications of digital radio communications systems. He began his career by participating in the SMAX TDMA-satellite communications program which was field-tested using NASA's ATS satellites in 1968. Since then he has been involved in the design of the

SPADE terminal equipment and also as a Project Engineer on various line-of-sight digital radio systems. He is presently an Engineering Manager of NEC Corporation's Satellite Communications Systems Division, where he is responsible for management of several INMARSAT projects including the Singapore coast earth station.

1. Introduction

In February 1982, the International Maritime Satellite Organization (INMARSAT) initiated operation of a modern satellite communications service for the global maritime industry. Toward this end, the Telecommunication Authority of Singapore (Telecoms) has built a CES at Sentosa (Fig. 1), to serve as the third CES in the Pacific Ocean Region (POR). This CES fully complies with the latest issue of INMARSAT's specification "Technical Requirements for INMARSAT Coast Earth Stations" and was successfully commissioned on 1 November 1982, after completion of all necessary verification tests as required by INMARSAT.

Under control of the Network Coordination Station (NCS) located in Ibaraki, Japan, the Singapore CES provides both automatic and operator-assisted telephone and telex services with call priority given to the distress communications. All ships, equipped for this service, can easily access or be accessed by any land subscribers in the world via the Singapore CES. Another outstanding feature is that Telecoms also has inter-ocean access arrangements with other CESs to provide worldwide coverage of the three ocean regions. Access to the Atlantic Ocean Region (AOR) is provided via the Goonhilly CES in the United Kingdom and

North-Holland

Space Communication and Broadcasting 2 (1984) 143-160

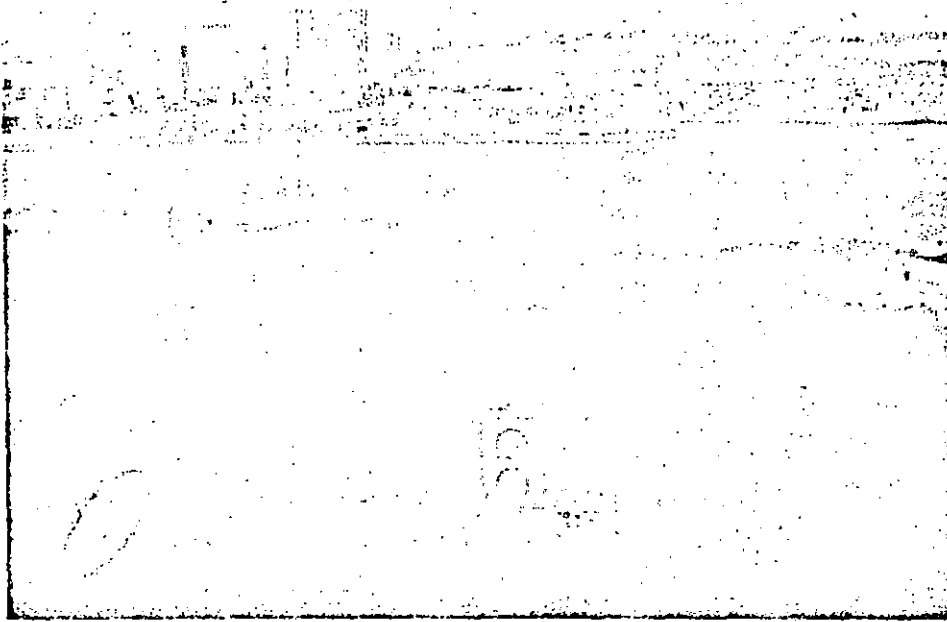


Fig. 1. Singapore coast earth station built in Sentosa (the center building with a roof-top antenna).

access to the Indian Ocean Region (IOR) is via the Eik CES in Norway.

This paper gives an outline description of the Singapore CES which also presents typical key approaches to design a reliable yet cost-effective CES system. The INMARSAT system incorporates some of the most advanced communications technology available in the world today. Voice and telex channels are assigned on demand with the voice channels using companded frequency modulation (FM) and the telex channels using time division multiplex (TDM) mode of operation in the shore-to-ship direction and time division multiple access (TDMA) mode of operation in the opposite ship-to-shore direction. The INMARSAT satellite transponders translate shore-to-ship signals from 6 GHz to 1.5 GHz and the ship-to-shore signals from 1.6 GHz to 4 GHz. For the detailed parameters of the INMARSAT communications system, we refer readers to [1].

Overall, there are two major design areas of primary importance: The first is incorporation of efficient L-band transmission with the C-band radio performance of the same quality as an IN-

TELSAT standard-B earth station. This is accomplished by the use of a C/L dual band antenna and L-band radio equipment which is all solid state. The second area is adoption of a suitable exchange control system to handle the INMARSAT traffic which is rather light and is a mixture of voice and telex calls. The solution to minimize both implementation and maintenance cost was to use a single central processor system providing common control of the voice exchange, telex exchange and associated system house-keeping functions.

Finally, a brief summary of the operational performances of the Singapore CES is provided.

2. CES configuration

The Singapore CES comprises four major equipment groups:

(1) The RF subsystem includes a 13 meter Cassegrain antenna, a C-band transmitter and an L-band receiver for the shore-to-ship (C-to-L) link and an L-band transmitter and a C-band receiver

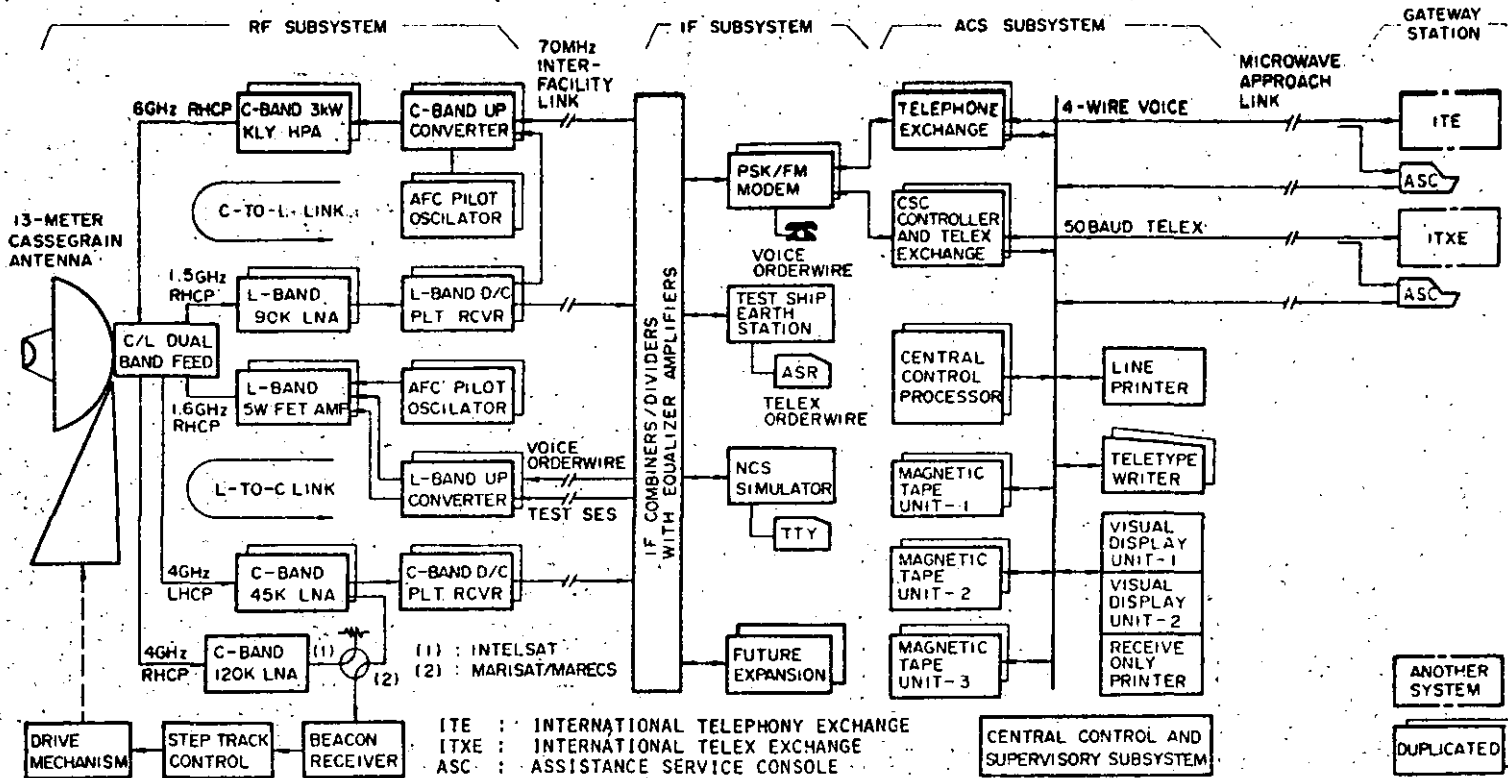


Fig. 2. Block diagram of Singapore coast earth station.

R.K.T. Fong, K. Kasni / Singapore earth station

for the ship-to-shore (L-to-C) link.

(2) The intermediate frequency (IF) subsystem includes PSK/FM modulator-demodulators, a test terminal used as a simulated ship earth station (SES) and an NCS simulator.

(3) The ACS subsystem includes a telex and telephone exchange equipment for the necessary switching and signalling functions of the calls initiated from both ships and inland networks. It also records all call data which is utilized for billing and statistical purposes.

(4) The centralized control and supervisory subsystem includes six consoles and two visual display units (VDUs) with a key board. The former summarizes all status displays of the equipment and provides remote control of the main RF equipment. The latter is used for traffic monitoring and control of the ACS subsystem.

A block diagram of the CES is shown in Fig. 2. The antenna is installed on the roof of a five-storey building, where all communications equipment and associated facilities including power supply system are accommodated. All essential equipment are fully redundant to meet the system availability requirement of 99.98%. The RF subsystem is connected to the IF subsystem via a 70 MHz-band 40 meter long interfacility link. The terrestrial interface with the ACS subsystem is achieved by transmission of the 4-wire voice and 50-baud telex INMARSAT circuits onto the existing 2-hop microwave link, which extends all Sentosa traffic to the gateway station. There, the international telephony exchange (ITE) and international telex exchange (ITXE) perform transit and domestic call connections. The INMARSAT assistance service consoles (ASCs) are installed in the same room as the ASCs of the ITE and ITXE to provide a suitable operator work environment.

3. RF subsystem

INMARSAT CES operation uses dual transmission of the C-band and L-band carriers. Therefore, the Singapore CES was constructed so that a cost-effective design could be achieved by integrating a purpose-designed antenna and frequency converters with standard RF components to produce

high-reliability performance equipment which can be maintained with the minimum effort.

3.1. Antenna

As the antenna is one of the most costly items in the CES facilities, any economies which can be made in this area are extremely worthwhile. In this respect, a single antenna having dual-band transmission capability was determined to be the best design approach for the INMARSAT CES.

The Singapore CES antenna comprises a 13 meter diameter main reflector, a shaped subreflector and a corrugated horn feed, which are configured in a modified Cassegrain geometry, and supported by a standard AZ-EL type mount structure widely used on many INTELSAT Standard B and Domsat systems. With the motorized screw jack mechanism, it is possible to steer the antenna continuously by $\pm 20^\circ$ in azimuth and $0-90^\circ$ in elevation. It is also possible to manually reposition the antenna over $\pm 130^\circ$ in azimuth.

Basically, the RF radiation system is so designed to provide optimum performance for the C-band. There, the corrugated conical horn maintains good axial beam symmetry and low sidelobes resulting in high antenna efficiency and low noise.

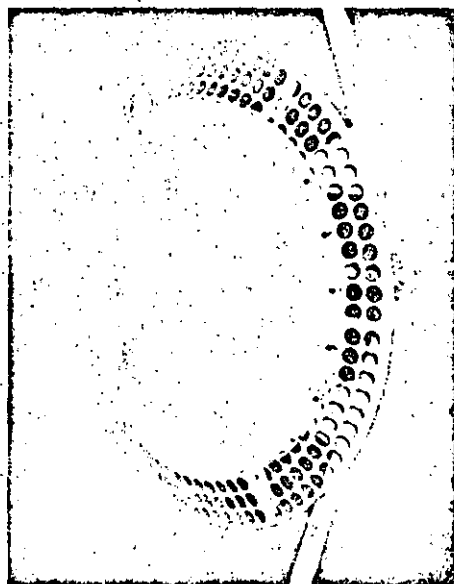


Fig. 3. Sub-reflector with a FSRS.

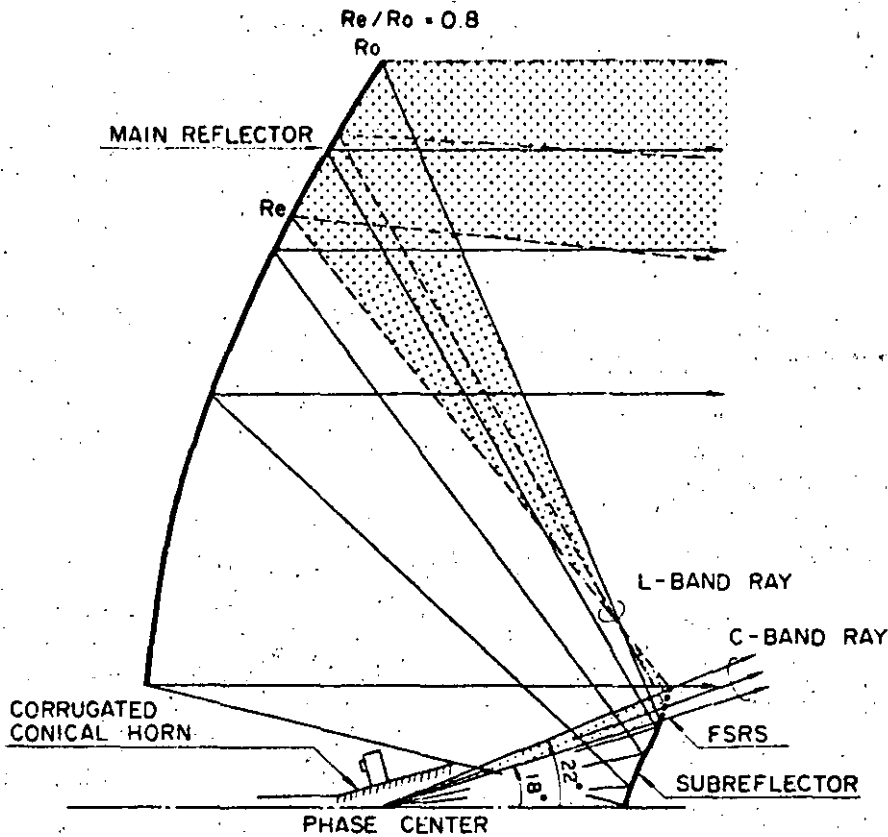


Fig. 4: Cassegrain geometry with RF optics (Main reflector diameter: 13 meter; Subreflector diameter: 1.95 meter; Primary horn diameter: 0.52 meter; Approximate F/D ratio: 0.35).

The horn also has four L-band injection ports arranged at the appropriate inter-sections. However, the horn produces a broad and asymmetrical beam for the L-band with high sidelobes causing a significant spill-over from the sub-reflector.

Therefore, in order to improve L-band sidelobe performance and antenna efficiency, a frequency-selective reflecting surface (FSRS) is provided around the periphery of the subreflector (see Fig. 3). The FSRS is transparent to the C-band waves and provides L-band reflection characteristic. With the antenna Cassegrain geometry shown in Fig. 4, the INMARSAT performance requirements are met on both bands as shown later.

A high polarization discrimination feed design for the C-band is achieved by employing the dual polarization frequency reuse techniques, developed

for the INTELSAT Standard-A and -B earth station antennas, which have been described in [2,3]. The feed configuration and its assembly are shown in Fig. 5 and Fig. 6, respectively. The feed assembly also includes waveguide components to provide a right-hand-circular-polarization (RHCP) L-band transmit and receive capability. The assembly is mounted in the antenna center-hub together with the low noise amplifiers (LNAs) and L-band power amplifiers which are described later.

Automatic step tracking system is used to track the maritime satellites. Left-hand-circular-polarization (LHCP) satellite beacons, derived from the C-band traffic receive chains, are used with the MARISSAT and MARECS satellites, and a separate C-band LNA is provided for the RHCP INTELSAT V satellite beacon.

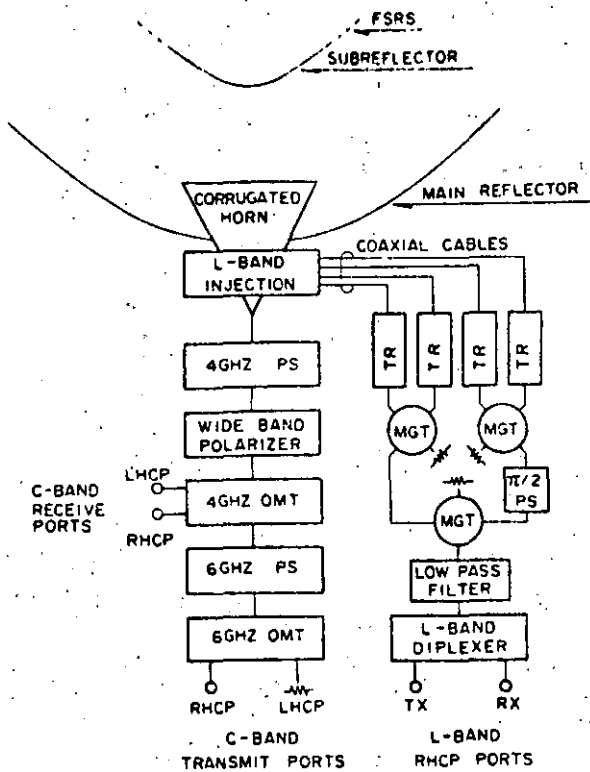


Fig. 5. Antenna feed configuration (PS: Phase shifter; OMT: Orthomode transducer; TR: Coaxial-to-waveguide transition; MGT: Magic T).

3.2. Frequency converters

The INMARSAT communications system uses a single-channel-per-carrier (SCPC) mode, and hence it is necessary for the CESs to perform automatic frequency compensation (AFC) of the carriers so that the SES's narrow-band receiver design can be as simple as possible. Another design feature of the RF subsystem is that this AFC function is efficiently incorporated in the up- and down-converter equipment.

To minimize the C-to-L link frequency errors caused by both satellite translation frequency instability and Doppler effect, all communications carrier frequencies must be pre-corrected before transmission. This is performed in the first mixer of the double conversion C-band up-converters. Since the Singapore CES is designated to transmit shared AFC reference pilots in the equatorial region of the satellite system, highly stable uncorrected C-band pilot frequencies are inserted after the first conversion. The pilot frequency is detected in the L-band down-converters by the pilot receivers which determine the frequency error accumulated in the link. The error signals are then fed to the first mixers of the up-converters to provide the necessary transmit precorrection control. In the separate L-to-C link, an L-band AFC pilot is also transmitted by the CES, which is

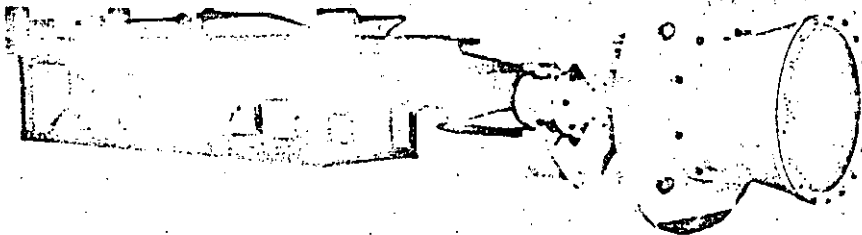


Fig. 6. Primary feed assembly.

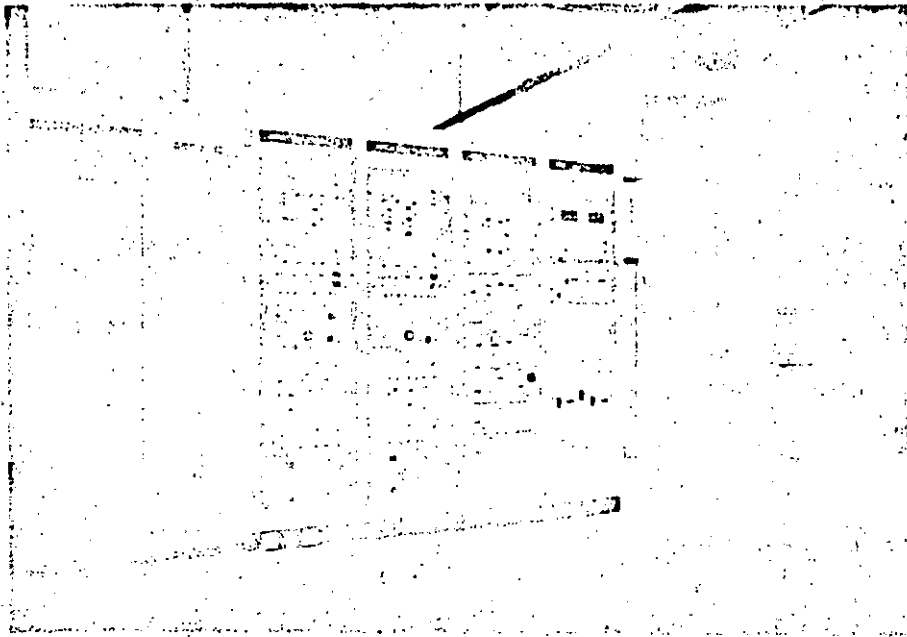


Fig. 7. Major RF equipment. From the right: Redundant 3 kW klystron HPAs; Local antenna control bay; Local LNA control bay; C-Band transmit and L-Band receive equipment; L-Band transmit and C-Band receive equipment.

detected by another pilot receiver in the C-band down-converters and post-corrects the received carrier frequencies for the following CES narrow-band demodulators.

In the frequency conversion process, the center of the IF spectrum is adjusted to 70000 MHz, corresponding to the RF channel numbered octal 252 (decimal 170), which is the center of the tunable band covered by SESs (8.5 MHz). All the frequency converters and AFC facilities are mounted in two standard 19-inch racks (see Fig. 7).

3.3. Power amplifiers

The redundant C-band high power amplifiers (HPAs) are standard 3 kW air-cooled klystron HPA's, tuned to cover the INMARSAT frequency band (see Fig. 7). The carrier effective isotropic radiated power (EIRP) can be adjusted over a 50-70 dBW range by the C-band up-converter line amplifiers and/or the HPA itself to minimize the level of the third-order intermodulation (IM) products. The maximum transmit carrier size, in

terms of equivalent voice channels, is 26 at 60 dBW EIRP (MARISAT) and 43 at 66 dBW EIRP (MARECS), complying with the linearity requirements specified by INMARSAT.

A maximum of three L-band carriers for the AFC pilot, voice orderwire and test SES are transmitted from the CES. Because of the higher L-band transmit gain available from the dual-band antenna, redundant field-effect-transistor (FET) power amplifiers, having a saturated output power of 5 watts across the 1626.5 to 1646.5 MHz band, are used for common amplification of the L-band carriers. The compact amplifier assembly is directly installed on the antenna feed in the center hub to minimize connection losses, and is temperature-compensated to provide ± 0.2 dB stability over the ambient temperature range of 0-50 degrees C. This design approach minimizes the cost of the L-band facilities.

3.4. Low noise amplifiers

Standard thermo-electrically-cooled parametric LNAs, designed for the INTELSAT system, are em-

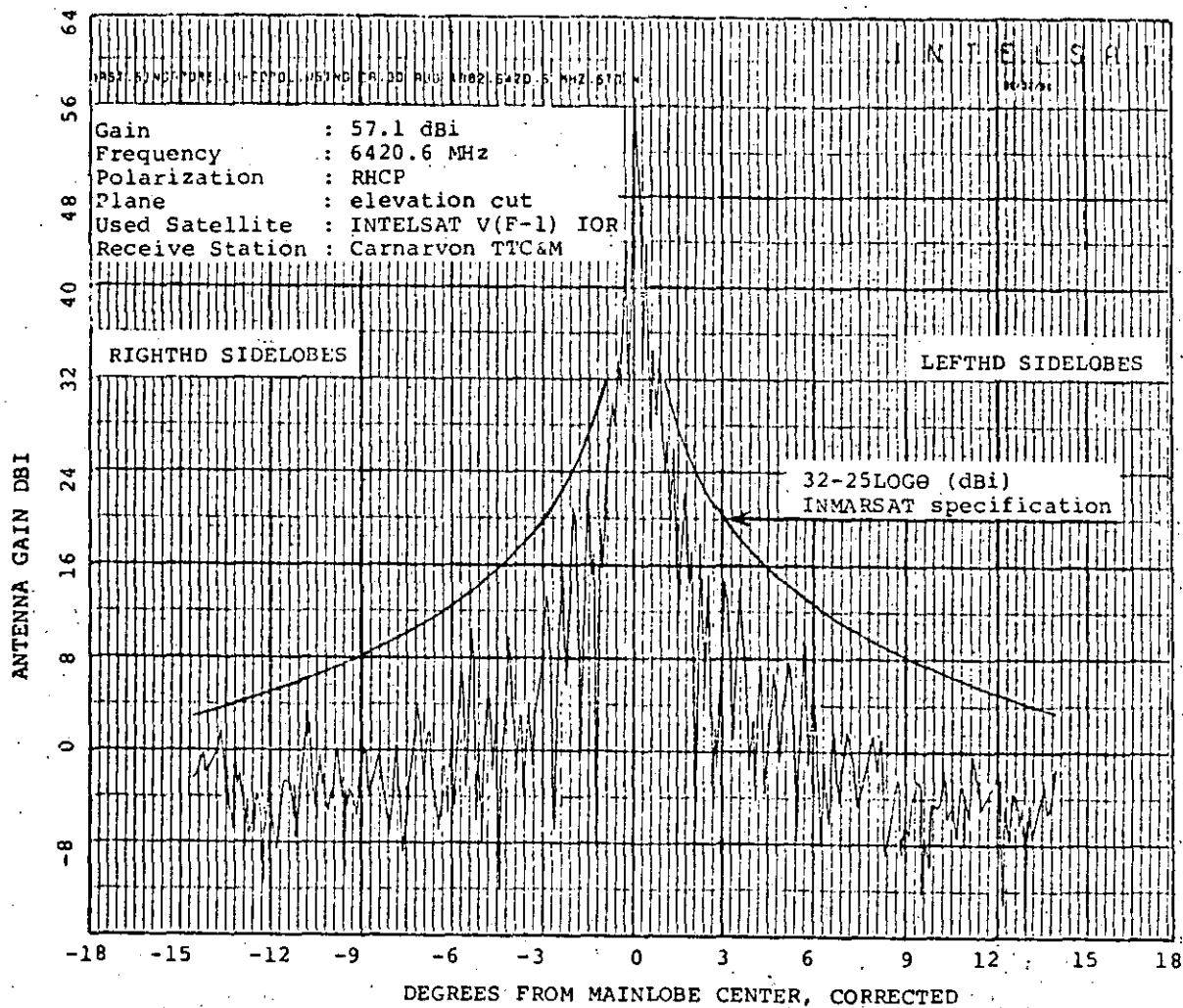


Fig. 8. C-band antenna transmit sidelobe pattern.

ployed for reception of the C-band carriers. Two redundant LNAs, with a noise temperature of 45 K over the 500 MHz bandwidth, and associated waveguide switches for redundancy control and test loops are mounted on a single plate and housed in the antenna center hub close to the feed. To simplify preventive maintenance, remote monitoring and control functions are provided in the RF equipment room. The gain-frequency response characteristic can be adjusted by remote control of the varactor diode bias voltage and Gunn diode oscillator pump power.

A new L-band LNA was designed for the INMARSAT system using gallium arsenide, Shottky-barrier field effect transistors (GaAs FET) whose noise and output power saturation characteristics are superior to those of Si bipolar transistors and tunnel diodes. Two redundant L-band LNAs, each with a noise temperature of 90 K over the 1530-1545 MHz band, are installed near the antenna feed to minimize receiver system noise. A non-redundant C-band FET LNA, with a noise temperature of 120 K, is used to receive the RHCP satellite beacon.

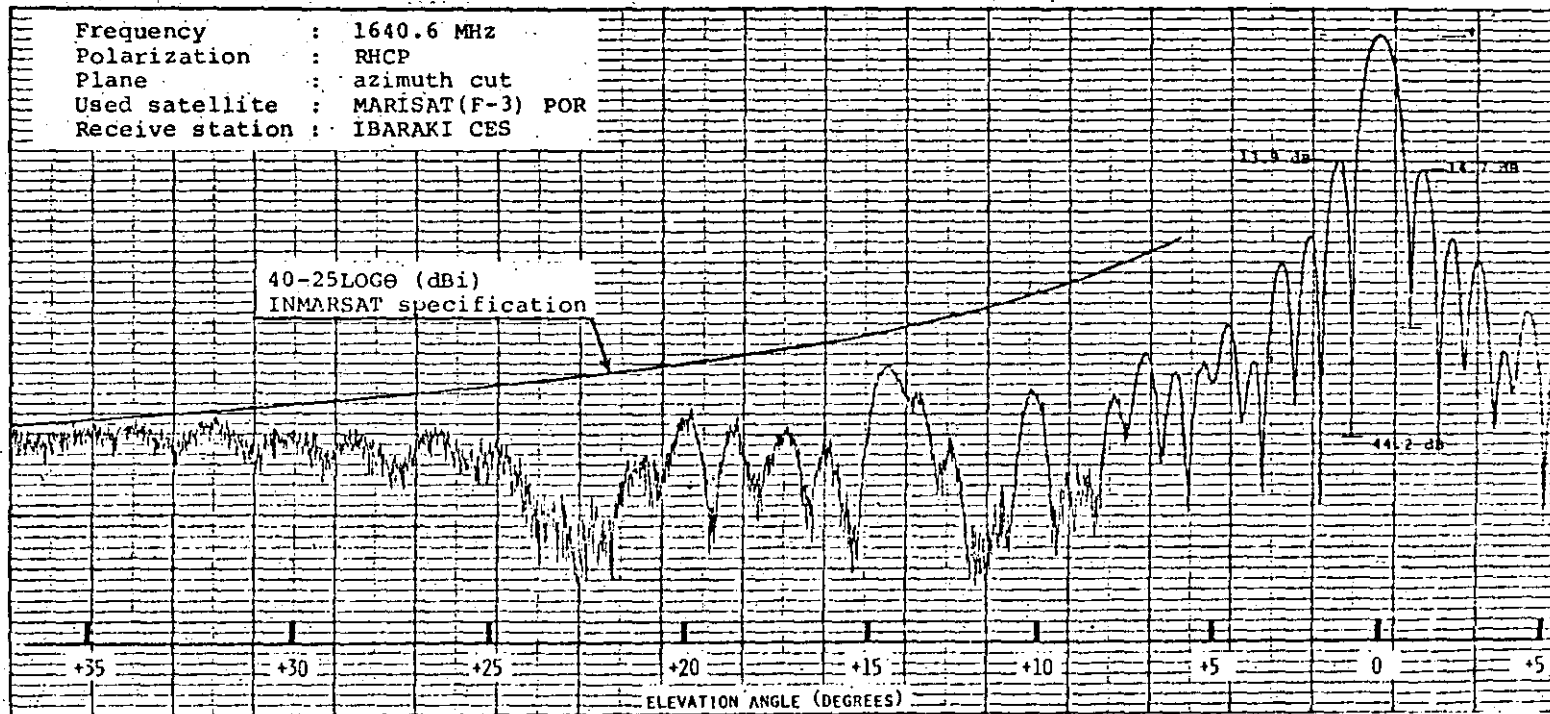


Fig. 9. L-band antenna transmit sidelobe pattern.

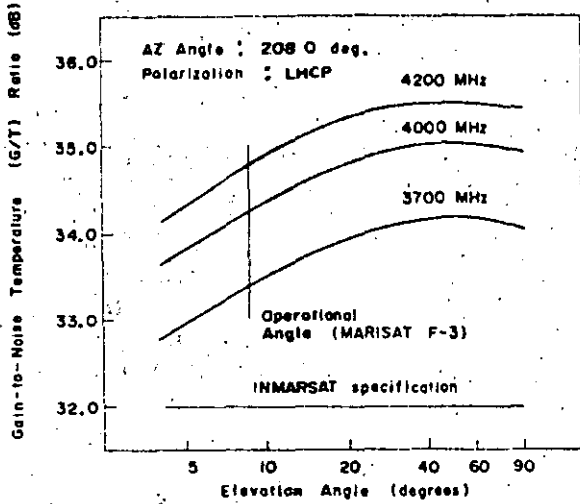


Fig. 10. C-band G/T ratio versus antenna EL angle.

3.5. Performance

The performance of the RF subsystem was measured in accordance with the CES verification test procedures provided by INMARSAT, and some of the major data is presented in Table 1 and Figs. 8 to 11. The C-band verification tests were conducted through the INTELSAT V (F-1) IOR satellite with the assistance of the Carnarvon earth station in Australia. The G/T performance was directly

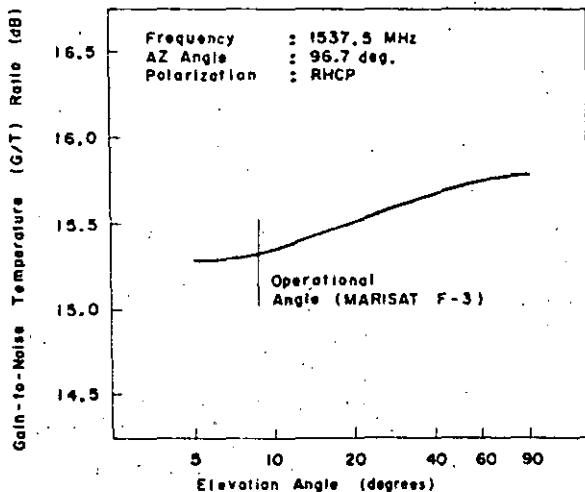


Fig. 11. L-band G/T ratio versus antenna EL angle.

Table 1
RF performance data

Parameter	C-band	L-band
Antenna frequency band		
Transmit	5925-6425 MHz	1626.5-1646.5 MHz
Receive	3700-4203 MHz	1530.0-1545.0 MHz
CES transmission band		
Transmit	6410-6425 MHz	same as above
Receive	4180-4200 MHz	
Receiver sensitivity (G/T) at 5 deg. elevation angle	34.3 dB/K (32.0 dB/K)	15.3 dB/K (2.0 dB/K)
Antenna gain		
Transmit	57.0 dBi (54.0 dBi)	41.9 dBi (29.5 dBi)
Receive	53.9 dBi (50.5 dBi)	39.8 dBi (29.0 dBi)
Receive half-power beam width	0.33 deg. (0.48 deg.)	0.93 deg. (6.2 deg.)
Polarization		
Transmit	RHCP	RHCP
Receive	LHCP	RHCP
Antenna axial ratio		
Transmit	0.31 dB	0.42 dB
Receive	0.14 dB (0.5 dB)	1.25 dB (2.0 dB)

(1) The above data are the lowest measured values over the CES transmission band.

(2) The figures in parentheses are specified INMARSAT system requirements.

measured using the radio star Taurus-A. The L-band verification tests were conducted through the MARISAT (F-3) POR satellite with the assistance of the Ibaraki NCS in Japan. The L-band axial ratios are typical values measured using a boresight facility.

The verification tests confirmed that all the RF performance met the INMARSAT specifications with more than adequate margins, as originally intended by Telecoms to ensure a longer life for the CES. The verification tests also confirmed that the C-band performance was satisfied over the full 500 MHz bandwidth. The measured antenna efficiencies and excellent sidelobe performances verified the suitability of the antenna design approach.

4. IF subsystem

All transmit and receive IF signals are concentrated at a single location to allow effective signal distribution to the system. For each RF chain, except the L-band transmit chain, an eight-port IF signal combiner or divider each with a cable equalizer is provided to allow free access to and from all IF equipment. The two L-band transmit chains are directly connected to the test SES and voice orderwire equipment via the equalizer. All IF chains have the same center frequency arrangement, compatible levels and a standard 75 Ohms impedance so that test loops can be established at the IF stage for debugging the ACS subsystem.

The PSK/FM modem equipment performs the necessary modulation, demodulation and baseband processing of both the communication and common signals in the system. The modem rack is designed to accommodate 22-telex and 10-telephony channels, including one orderwire circuit, in a single 19 inch wide cabinet, satisfying the expected initial INMARSAT traffic requirements. Additional modem racks can also be connected to spare IF ports for future expansion.

The test SES is derived from the standard SES's below-deck equipment which has been type-approved by INMARSAT. It is modified for a 70 MHz interface for signal connection, and has the additional function of automatic repeat transmission of the request messages on a command basis which is effective in assisting preventive maintenance of the ACS subsystem. In normal operation, the test SES is used for telex orderwire communications between the CESs.

The NCS simulator is a microprocessor-controlled test terminal which simulates the NCS functions. It contains PSK modems and an associated baseband processor to perform pseudo-sequential signalling under control of the stored programs and the teletypewriter (TTY) command. Both the test SES and NCS simulator are essential tools for debugging the ACS subsystem during initial alignment and operational routine maintenance phases.

5. ACS subsystem

Normally, each CES in the satellite system acts as an inland maritime switching center for inter-connecting the terrestrial network and the satellite system. The major functions include:

- (1) NCS-assisted 'demand assignment multiple access' (DAMA) control of the satellite circuits;
- (2) line exchange between the satellite and terrestrial parties with the associated signalling conversion for both voice and telex calls, and
- (3) recording call data for the maritime charging and accounting system.

Given a design task of providing the above-stated multiple services, one could choose a multi-processors system where the tasks are shared by distributed processors with each task being controlled by one system processor. However, this approach requires a rather complicated architecture and sophisticated software control. Therefore, in order to provide a cost-effective and easy-to-operate system, it was decided to adopt a central processor control system, where digital voice and telex exchange equipment could be used under the common control of a central processor system.

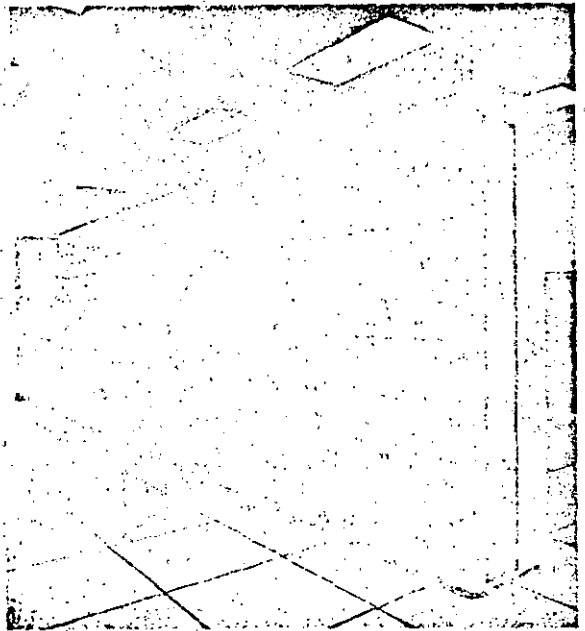


Fig. 12. ACS subsystem equipment.

which would perform all the afore-mentioned jobs on a time-sharing basis.

5.1. Configuration

As shown in Fig. 2, the major constituents of the ACS subsystem are:

- (1) telephone exchange equipment;
- (2) telex exchange equipment with the associated common signalling channel (CSC) controller, and
- (3) the central control processor with its peripheral equipment.

All essential equipment is in a fully redundant configuration and housed in five standard racks with an overall length of 5.1 meter and 2.1 meter height (Fig. 12). The peripheral equipment include three magnetic tape units (MTUs) for data storage and the input/output devices which include two teletype-writers (TTYs), a line printer (LP) and two color visual display units (VDUs) with a receive-only-printer (ROP). Telephone and telex assistance service consoles (ASCs) are provided at the gateway station.

5.2. Central control processor

NEC model S6000-51 processors (Fig. 13) are used to control the whole ACS subsystem. As the processor was developed for exclusive use in a

digital exchange, it has adequate capacity to control dual exchange equipment so that the on-line maritime calls can be processed in a most efficient and reliable manner. The 16 bit central controllers (CCs) execute the operation programs stored in the main memories (MMs) at an average speed of $1.69 \mu\text{sec}$ per instruction and 600 nsec for a complete memory cycle. Each MM has a 1536 kilo word memory capacity which is also sufficient to store data for 10000 calls. One of the redundant MTUs stores all programs for initial program loading (IPL). The second and third MTUs are provided for simultaneously recording call data onto two redundant magnetic tapes (MTs) for security purposes. An emergency action circuit (EMA) will automatically reconfigure an operational CC-MM combination upon detection of a failure of CC, MM or program and it can also periodically activate a CC-changeover once every 24 hours for preventive maintenance. All peripheral equipment is controlled by four controllers via the bus system. The data channel is an interfacing device to facilitate data transfer between the CCs and the highly integrated bus system. Major control of the exchange equipment is performed by the central processors, via the speech bus modules (SPBMs), which leave the local line supervision and control functions to the firmware in the exchange equipment.

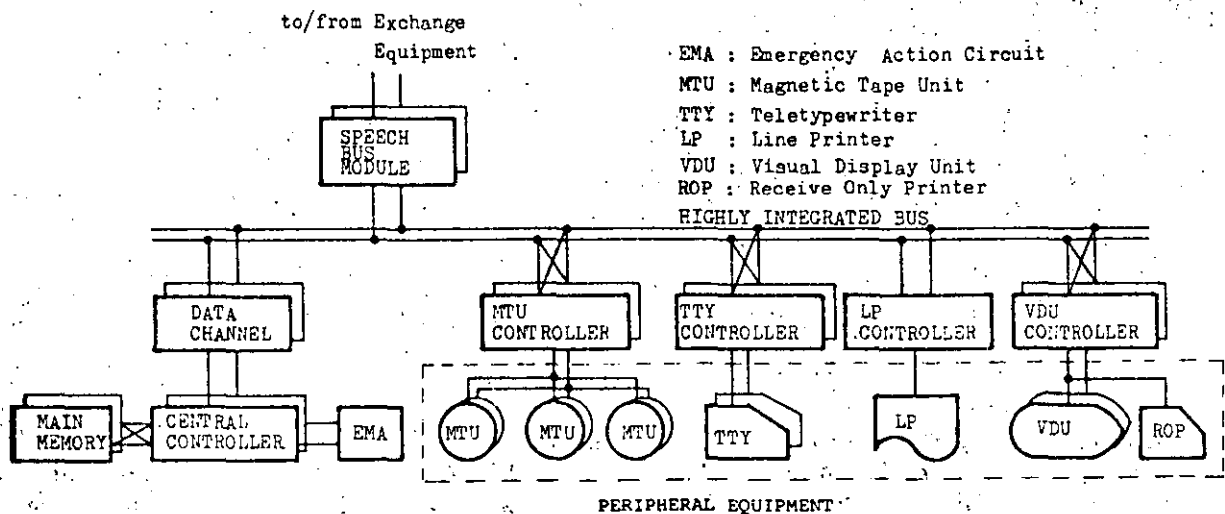


Fig. 13. Block diagram of central control processor.

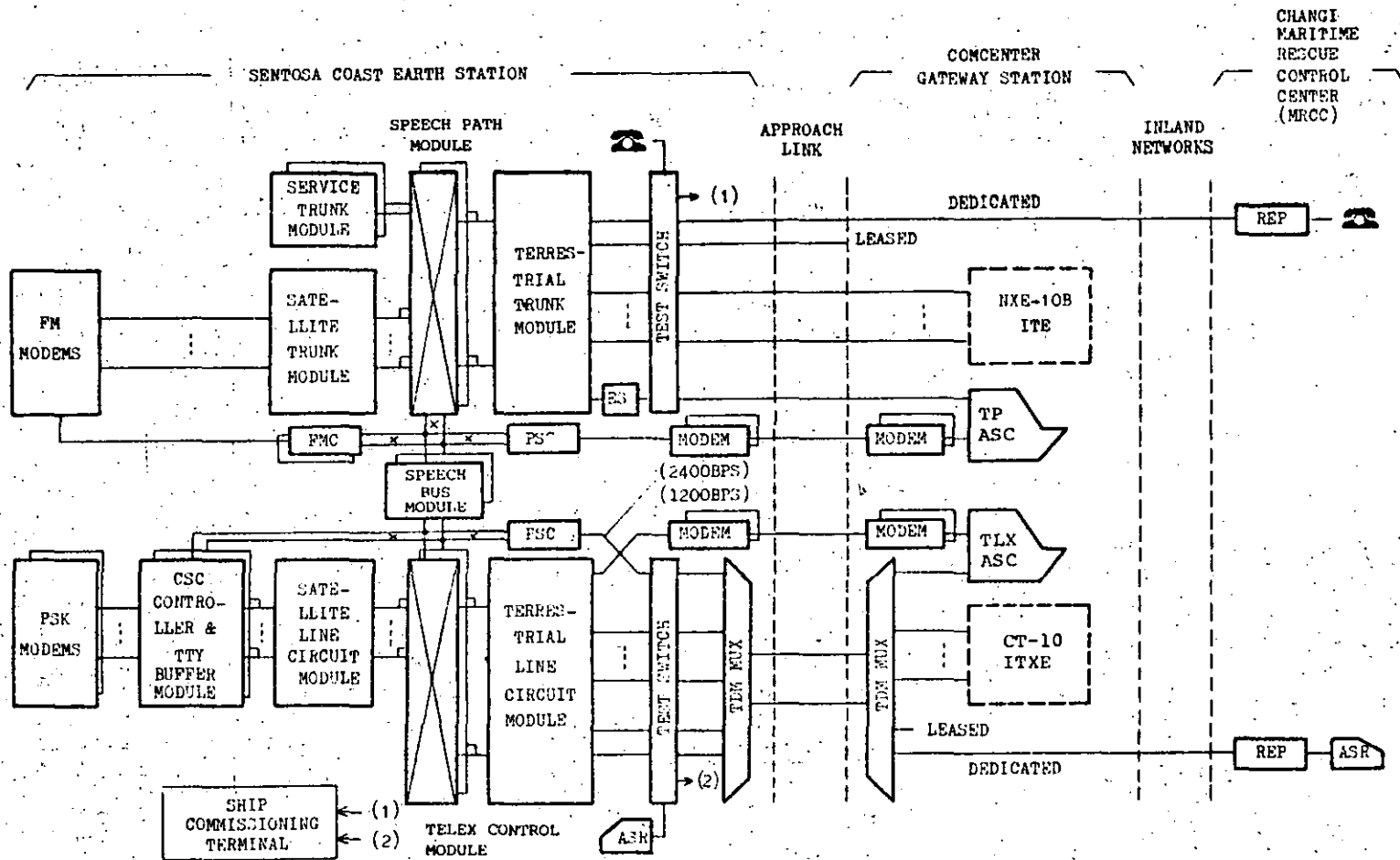


Fig. 14. Exchange equipment configuration.

R.K.T. Fung, K. Kozul / Singapore earth station

Table 2
Channel capacity

Circuit		Initial	Final	
<i>Telex</i>				
Satellite	Bothway	22	198	
Terrestrial	Ordinary	Ship-to-Shore	13	138
		Shore-to-Ship	7	60
	Leased	Ship-to-Shore	2	24
		Shore-to-Ship	2	12
	Dedicated	Bothway	2	6
	<i>Telephony</i>			
Satellite	Bothway	7	42	
Terrestrial	Ordinary	Bothway	7	42
		Ship-to-Shore	1	12
	Leased	Shore-to-Ship	1	6
		Bothway	2	6

5.3. Telephone exchange equipment

The exchange equipment and the interfacing facilities are shown in Fig. 14. The telephone exchange equipment uses a standard NEAX 61 digital exchange design, providing the minimum switching capacity required for the maritime traffic. The number of trunk circuits provided initially and the final expansion capacity are given in Table 2. The analog voice signals originating from the FM modems and terrestrial networks are converted to PCM signals in the both-sided trunk modules, where 'per-channel' PCM coder-decoders with an 8 kHz sampling rate and A-compression characteristics are combined with the E&M or CCITT standard No. 5 (for the interface with the NXE-10B gateway telephone exchange system) signalling circuits. The service trunk modules (SVTMs) include the board trunk circuits for the ASCs, multi-frequency senders-receivers to handle the register signals for the gateway exchange, push-button receivers for the key-set codes from the SESs and tone generators to provide dialling/ringing/busy/congestion information tones to callers. They also operate in a PCM mode under control of the speech path modules (SPMs).

The SPMs are the nerve center, which performs the time-division-multiplexed (TDM) switching function on a PCM-highway, where all traffic and service signals are arranged in an appropriate TDM

format. The frequency assignment of the FM modem and ASC control are given directly by the central processor via the FM modem controllers (FMCs) and position controller (PSC), respectively.

The ASC calls are routed through echo-suppressors (ESs) at the exchange output and the two-wire termination at the ASCs are extended to the remote gateway station together with the control signals which are transmitted by data modems on voice lines.

5.4. Telex exchange equipment

The telex exchange equipment uses a standard NEDIX 510A design which also has the same processor control as the NEAX 61. The equipment accepts the 50-baud telex circuits for TDM switching, which is performed by the redundant telex control modules (TCMs) with a switching capacity for 240 bothway circuits. The both-sided line circuit modules provide line conditioning for each telex channel and formatting to a PCM highway suitable for the TDM switching. The numbers of line circuits are given in Table 2. The ITXE signalling interface uses a CCITT type-B key board signalling system.

Since the satellite out-of-band signalling and telex messages are combined in a specific TDM format, additional signal conversion is required between the PSK modems and telex exchange equipment. The CSC controllers handle the various out-of-band signals for satellite transmission under direct control of the central processor. The TTY buffer modules multiplex and demultiplex the 50-baud telex messages to and from the TDM data specified for the satellite system. The ASC telex calls are also extended to the gateway station.

5.5. Test switch

Circuit test equipment is provided between the ACS exchange and the gateway station whose functions include monitoring both the terrestrial and satellite circuits and testing the ACS exchange signalling protocols by an automatic insertion and drop of the test circuit. The circuit test equipment can also be effectively used to simulate the ACS

subsystem and/or the gateway to verify the system operation in both directions.

5.6. Assistance service console

Operator assistance is provided for enhanced maritime services. Redundant telephony and telex ASCs are included in the ACS subsystem to handle calls originated from both the SESs and inland subscribers. The ASCs are located in a suitable room at the associated gateway exchange and operated by remote control from the ACS-central processors. The merits of this arrangement are twofold. Firstly, the interfaces with the existing ITE and ITXE can be simplified and do not require modification. The operator can directly access the ACS subsystem, where all maritime call data is collected, allowing a unified charging and accounting system. Secondly, the maritime operator assistant work can be supervised by the overall gateway operator management, and also provides the maritime operators with a comfortable work environment. Both ASCs are controlled by the central processors via the data links established through voice circuits, whilst the handling calls are routed from the corresponding terrestrial trunk and line circuits of the ACS exchange equipment.

5.7. Software

The software is an integral part of the CC-controlled ACS subsystem and essential for verifying performances, efficient switching and the associated service features. The on-line software is functionally divided into five programs:

(1) The Execution Control Program (EP) is used to exercise general management and scheduling of the entire switching process by control of the input/output devices and common memory area.

(2) The Call Processing Program (CP) is used to handle telephony and telex calls with a variety of signalling, numbering, charging and operation services.

(3) The Administration Program (AP) is used for office operation including normal exchange maintenance, circuit supervision, ship file maintenance and call data recording.

(4) The Fault Processing Program (FP) is used

to maintain service continuity should any failure occur by controlling the redundant equipment configuration.

(5) The Diagnostic Program (DP) is used for fault location and a diagnosis print-out.

The EP, FP and some part of the CP are written in S6000 assembler language to meet the severe real-time requirements for efficient exchange operation.

Other large programs which do not require realtime operation are written in PLC-6000 high level language which conforms to the CCITT-recommended CHILL. A modular program structure is applied wherever applicable to the software to allow easy functional modification and addition of new services. Minor modifications are possible utilizing built-in debugging aids such as memory trace, dump and patch facilities. The ACS programs are also backed up by complete support software tools for larger modifications.

5.8. Call services

The ACS subsystem is capable of providing the following call services to the subscribers:

(1) Automatic and operator-assisted telephone and telex calls.

(2) Telephone and telex distress calls from SESs to the Changi maritime rescue coordination center (MRCC) on a pre-emptive priority basis.

(3) Telephone and telex search and rescue (SAR) calls from the Changi MRCC to SESs with the same priority as above.

(4) Two-digit code calls for special services including telegram, technical assistance and credit card calls.

(5) Two-digit code calls for urgency and safety services for SESs including medical advice, medical assistance, meteorological reports and navigational warnings from SESs.

(6) Medium speed data (up to 2400 bps) service on telephone circuits.

(7) Broadcast calls to all SESs and group with selectable nationality, fleet and geographical area.

(8) Ship-to-ship calls.

(9) Test calls for the commissioning SES.

(10) Leased circuit calls.

When the Singapore CES is called by a dis-

tressed SES, the call is automatically routed to the Changi MRCC with E&M signalling via the dedicated circuits. In case the dedicated line is congested, an overflow call will also be extended to the MRCC via another public line using the ACS auto-dialling facilities. The ACS subsystem is capable of simultaneously handling 3 telephone and 3 telex calls per second.

5.9 Other features

The ACS subsystem performs the following house-keeping functions on a time-sharing basis while processing real-time calls:

(1) *Call data record.* Each time a call is processed, the characteristic data are temporarily stored in the MMs. When data from 16 calls has been stored in the MMs, the block data is transferred to the MTs. Security of call data is ensured by memory protection devices in the MMs and the read-after-write MTU system using a parity and

cyclic-redundancy check (CRC) method. The MT record design format is based on the INMARSAT specification adding other information which is needed for preparing customer bills. The MTs are sent to another computer center for off-line processing.

(2) *System supervision and control.* More than 50 autonomous supervisory messages and 35 commands are available for the ACS system. Normally, the TTYs supervise and control equipment failures and redundancy switching, whilst the VDUs with a keyboard handle events associated with call processing. Hard copies of the VDU are also available on the ROP. Urgent messages have an audible alarm to attract operator attention. In order to prevent command abuse, two-level passwords are required for data change commands.

(3) *Traffic statistics.* Maritime traffic can also be analyzed on the recorded call data. By using appropriate commands with the prepared search indexes, a number of processed calls can be classi-

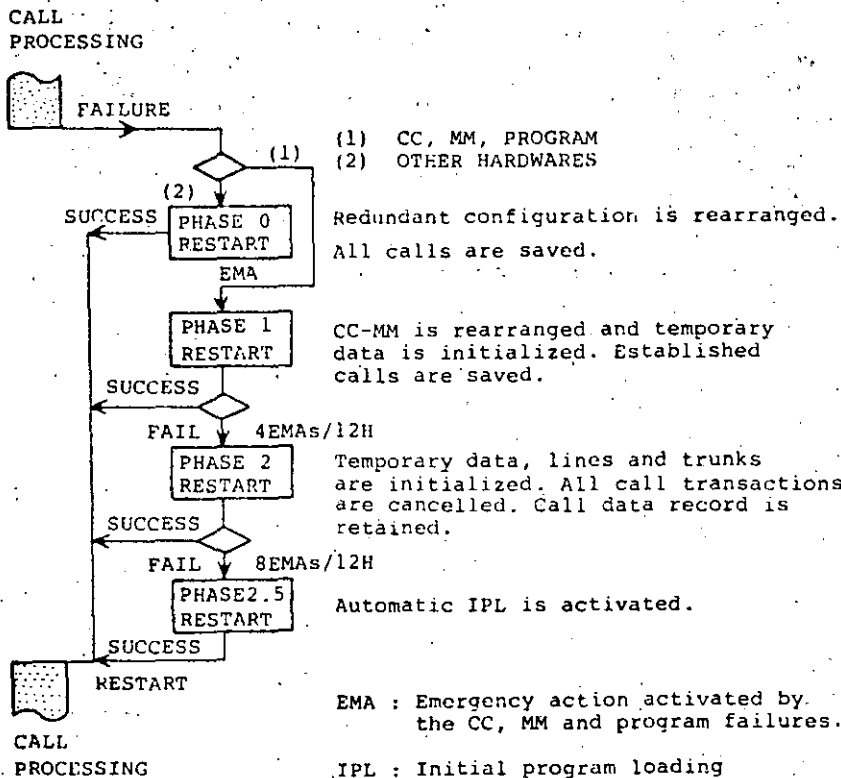


Fig. 15. ACS subsystem restart processes.

fied in event time, SES identification, call orientation and effectiveness. The central processor efficiency is given as a percentage and the traffic loads on the TTE, ITXE and satellite circuits are given in erlangs.

(4) *Ship file management.* Prior to entering the INMARSAT communications system, each commissioned SES must be registered in the CES ship data file with the ship identification code. New registrations and the file revisions can be performed at the VDU and key board terminal. The file capacity is 120 kilo words to maintain a maximum of 20000 SESs.

(5) *Fault processing and diagnosis.* The ACS common equipment is fully redundant and is normally operated in a hot-standby mode. Should the equipment or software fail, an automatic restart processing is initiated to ensure continuous and uninterrupted operation. The recovery processings are classified depending on the failure mode as shown in Fig. 15. The phase 1 and 2 restart processings take less than a second and the IPL can be completed within 5 minutes.

For identifying and locating faults to a card or group level, built-in diagnostic programs are executed by a command from the faulty ACS subsys-

tem which is switched to independent operation from the on-line system. The separate mode is also effective for debugging the software while the system remains in service.

6. Centralized control and supervisory subsystem

The remote control and supervisory facilities for the RF subsystem are centralized in the ACS equipment room for the maintenance convenience (Fig. 16). The facilities include the following six consoles and the VDUs mentioned before:

- (1) Antenna console housing the beacon receiver, antenna position indicator and control unit;
- (2) C-to-L band equipment console;
- (3) L-to-C band and modem equipment console;
- (4) Mimic panel console indicating the whole CES traffic path;
- (5) ACS subsystem console mounting an equipment status display panel, and
- (6) Orderwire console to provide the push-to-talk telephony circuit with push-buttons for selective calling.

Local control and supervisory facilities are also

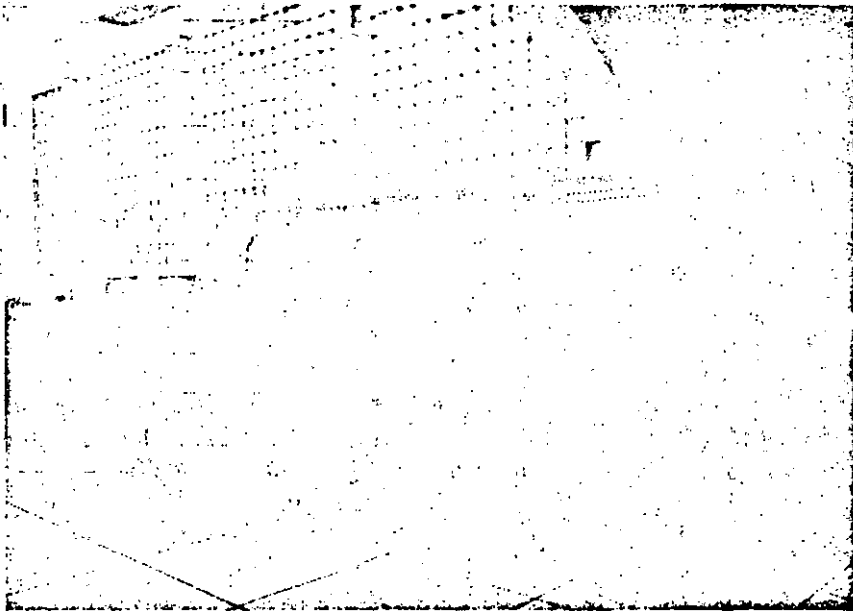


Fig. 16. Centralized control and supervisory consoles and visual display units.

provided in the RF equipment room. However since it is normally unattended, control priority is passed to the central area except for the C-band HPAs.

7. Operation status

The maritime traffic handled at the Singapore CES has seen a steady increase month by month since the inauguration of commercial services last November. Since February 1983, the total number of successful calls per month has been maintained at around 7000 with telex calls accounting for more than 80% share. From an analysis of the call data records, it was found that the ship-originated calls have higher successful rate than the shore-originated calls. The main reasons of unsuccessful ship-originated calls are (i) shore subscriber busy, or (ii) wrong numbers called.

Whereas, the main reasons for unsuccessful shore-originated calls are (i) absent SESs; (ii) SES malfunction; (iii) wrong numbers called, or (iv) other causes attributable to operational unfamiliarity by the callers.

Every effort has been made to increase the successful call rate for both ship- and shore-originated calls. It is believed that the maritime calls will be greatly improved in the near future when information on the SES location and operational status is more readily available to shore subscribers. Additional services for 56 kbps high speed data circuits will be implemented if there is sufficient customer demand.

The overall station performance of the Singapore coast earth station has been maintained satisfactorily with high reliability as expected. The RF performance using MARISAT satellite has been

satisfactory to date except for several intermittent loss of antenna tracking and AFC synchronization during the period between mid-October and mid-November 1982, due to fading caused by scintillation. The fading occurred during the night, with each occurrence lasting between 30 and 180 minutes. This fading is believed to be due to the ionospheric scintillations because fading was prevalent after local sunset near the equinoxes [4].

8. Conclusion

The dual band RF terminal and state-of-the-art digital exchange equipment are merged to provide a new computer-and-communications-oriented earth station. The design has been satisfactorily verified by the extensive field data, establishing a typical design approach for a maritime mobile satellite communication system. The general design concepts are applicable not only to the second generation of the INMARSAT system but also to aeronautical and land mobile satellite communications systems which may be introduced in the near future.

References

- [1] T. Takahashi, The INMARSAT System and its Future Development, AIAA-82-0472, 1982.
- [2] S. Soma and I. Sato, Dual Polarization Antenna Technology in Satellite Communications, INTELCOM-77, Atlanta, Georgia, 9-15 October 1977.
- [3] S. Soma et al., A High Performance Mode Transducer/Polarizer Assembly in the 4 GHz and 6 GHz Bands, *IEEE/AS-S* (1974).
- [4] D.J. Fang and M.S. Pontes, 4/6 GHz Ionospheric Scintillation Measurements During the Peak of Sunspot Cycle 21, *COMSAT Technical Review* 11 (2) (1981) 293-320.

THE SERVICES AND OPERATIONAL
CHARACTERISTICS OF THE EUTELSAT SYSTEM

FOR T.M. GALANTE

E U T E L S A T



THE SERVICES AND OPERATIONAL CHARACTERISTICS OF THE EUTELSAT SYSTEM

Fabio M. Galante

Interim EUTELSAT
Paris, FRANCE

ABSTRACT

The paper describes in general terms the technical and operational features of the EUTELSAT network devoted to offering both international digital communication services easily accessible by customers and space segment capacity offered for lease. The monitoring and control network of the overall system is also presented.

1. INTRODUCTION

The regional European satellite system was initially conceived as a reinforcement of the European terrestrial network for conventional public international telecommunication services. The system originated as a two-satellite system (10°E and 13°E orbital positions) designed to carry 12,000 circuits using TDMA/DSI and two analog TV channels.

Advances in satellite and communication technologies and the consequential reduced cost of satellite communication, have opened the trend to use satellite systems for non-conventional services also.

A substantial market for transponder leases for national and international applications has developed, while demand for business-oriented services is emerging.

Recognizing the above, the regional European system has evolved to offer business-oriented communication and transponder leases in addition to the purpose for which it was initially conceived.

The purpose of this paper is to describe the technical and operational arrangements under which these new "services" are offered. The characteristics of the system for the public international telephone service have already been reported in the publications indicated as references.

2. BUSINESS ORIENTED SERVICES

A business communication network differs from a conventional network because:

- (1) the core of the traffic consists of sources like teleconferencing, data transfer and facsimile rather than voice. The network will therefore have to meet different performance

objectives;

- (ii) economic and operational considerations dictate the use of small earth stations that will directly access the satellite, thereby creating a dispersal and multiplicity of earth stations that require sophisticated network control;
- (iii) it has to meet the following requirements:

- rapid expansion or redistribution of capacity in the network to meet customers' needs;
- provide direct links to customers' locations;
- set up short duration links in a number of places consecutively.

The EUTELSAT Satellite Multiservice System (SMS) has been designed to meet these requirements and it can be visualized as a switched multiservice network offering its users access to a range of services having different transmission and operational characteristics, not currently available on terrestrial transmission systems.

This system will comprise two parts forming two separate networks, one using ECS space segment facilities (the ECS part), the other using space segment facilities of the French domestic satellite system TELECOM 1 (the TELECOM 1 part).

The services to be provided by the EUTELSAT SMS are the following:

(a) TELECOM 1 Part:

- circuit switched service;
- reservation service;

(b) ECS Part (initial phase):

- full-time leased service;
- part-time leased line service (circuit established according to previous reservation).

The above services will be offered in a point-to-point and in a point-to-multipoint configuration, in a unidirectional or bidirectional mode.

Specific applications for which the system is particularly suitable are videoconferencing, audioconferencing, computer-to-computer transfer, remote printing, packet switched data carrier, fast facsimile, teletex, slow scan TV, and electronic mail.

2.1. The ECS SMS network

The SMS package incorporates two 14/12 GHz transponders of 80 MHz bandwidth. The specified coverage zone corresponds to the area to be covered by the -3dB beam contour. Portugal, Turkey and northern parts of the Nordic Countries are covered by the -4dB beam contour (see Fig. 1).

The access to the transponder is in FDMA with each channel being transmitted on an individual carrier (SCPC/FDMA). The modulation method is 4 phase CPSK.

Standard earth stations will require approximately a 5m dish and a clear sky G/T of 30.5dB/K. Stations with a 3.5m dish and a clear sky G/T of 27.5 dB/K can also be used.

The maximum EIRP requirements for the 5m dish are 57.2dBW for the smallest carriers (64 kbit/s customer data rate) and 72 dBW for the largest carriers (2 Mbit/s customer data rate). The lowest input data rate transmitted by the SCPC equipment is 64 kbit/s, lower bit rates (2.4, 4.8 and 9.6 kbit/s) can access the system using CCITT X.50 framing.

With an earth segment consisting of 5m antenna stations, the traffic handling capacity of the ECS part of the EUTELSAT SMS is equivalent to 570 channels of 64 kbit/s (customer rate) with one transponder in operation. This capacity is for standard performance channels having a bit error rate no greater than 1 in 10^6 for 99 % of the year. Higher performance channels (e.g. having a BER no greater than 1 in 10^{10} for 99 % of the year) can be provided by increasing the channel carrier power, with a subsequent reduction in overall capacity.

2.2. The TELECOM network

Five of the six transponders of TELECOM 1 at 14/12 GHz band will be used for SMS operation and access to them will be by TDMA at a transmission rate of 24.576 Mbit/s. The modulation method is 2 phase DPSK.

The satellite antenna coverage is specified as six different zones, resulting in six different sets of earth station characteristics. Zone 6 constitutes the limit for operating within the TELECOM 1 antenna beam. (See Fig. 2).

Each earth station transmits to only one transponder, but receives from all five transponders in a frequency-hopping mode. Acquisition and synchronization of the TDMA terminals in the earth stations will use information provided by the Reference Station which is a part of the TELECOM 1 System Management Centre (SMC).

Earth stations for use within Zone 1 and Zone 2 use a 3.5 m antenna. Earth stations for use within the other zones, require antenna diameters ranging between 4 and 8 m.

Standard performance channels have BER no greater than 1 in 10^6 for 99 % of the year. The capacity available is equivalent to 150 x

64 kbit/s standard performance channels (customer rate). As an option, higher performance channels are offered having a BER no greater than 1 in 10^{10} for 99 % of the year. This higher performance is achieved with forward error correction (FEC) using a 4/5 Hamming block code, with a consequent reduction in overall channel capacity.

3. TRANSPONDER LEASE SERVICES

Even though the communication techniques used in the leased transponders may or may not be of the conventional type, the institutionalized possibilities of leasing transponder capacity in orbit can be considered a new service in its own right. The ECS system offers a variety of different leases, each of which is tailored to specific requirements, classified as follows:

- full-time long term, partial or full transponder lease,
- regular part-time, partial or full transponder lease,
- full-time short term, partial or full transponder lease,
- occasional lease.

To satisfy the high level of demand for cable TV feeds in Europe, the transponders of the EUTELSAT system's spare satellite are leased on a prearranged basis.

The resources available for lease capacity allow for a large variety of transmission characteristics; for example, a typical television link using Eurobeam up-link and Spotbeam down-link (see Fig. 3), would have the following characteristics:

transmit earth station EIRP	: 82 dBW
receive earth station diameter	: 5m
receive earth station G/T	: 30.5 dB/K
S/N (99% of worst month)	: 51 dB

It is worth noting that the antenna diameter is the same as that of the antenna required for SMS services. Studies regarding a possible harmonization of the characteristics of the earth stations, and the associated equipment necessary for receiving the various TV signals transmitted via leased capacity, are being carried out. Studies include harmonization of encryption methods and audio and video standards.

4. MONITORING AND CONTROL

The diversity of services available through the EUTELSAT system necessitate a highly developed management support system. Particularly, the flexibility offered by the SMS service and the complexity of the TDMA system for conventional telephony require a close control of carrier and burst allocation and close monitoring once they are established.

The Communication System Control Centre is the overall control and coordination centre for the system. A conceptual block diagram is shown in Fig. 4.

- The main activities of the CSC are to:
- coordinate and control the availability and use of the capacity for TDMA telephony traffic, SMS and leased capacity
 - collect data on system and satellite performance
 - liaise and exchange data with the satellite control centre and the TELECOM 1 management centre
 - initiate and coordinate implementation of operational plans, transition and contingency plans.

The CSC is connected to the following installations:

- TDMA reference and monitoring stations (TRMS) in Italy and Spain
- Lease capacity monitoring stations in France and the U.K.
- SMS monitoring station and SMS pilot generating stations
- Satellite Control Centre in Belgium
- Earth station verification and assistance (E.S.V.A.) and in-orbit test (I.O.T.) facilities
- The TELECOM 1 System Management Centre (SMC).

The spreading of dedicated monitoring and control functions allows for efficient use of existing ground facilities with consequential investment savings.

The TRMS stations perform the reference function for the system by providing the timing and the synchronization control of the traffic terminals. They ensure proper system management by continuously monitoring the position, presence and the service channel of each traffic burst. Several parameters of the system are monitored to constantly check the system performance and to assist terminals during line-up.

The SMMS station in connection with the CSC has the specific role of receiving and handling requests for circuit reservation, allocating and authenticating carriers and recording traffic performance. The CSC and the SMMS station are also connected to National Control centres in each member country whose responsibility it is to see that the manned or unmanned SMS stations under their control, do not affect the system's security. SMS pilot-generating stations have the function of providing pilot frequencies to allow SMS traffic stations to track the spacecraft.

The satellite control centre, operated by the European Space Agency, is in charge of monitoring and controlling the spacecraft. The ESU centre is responsible for the operation of the Eurovision network of which the EUTELSAT satellites are an integral part.

The CSC is also connected to the TELECOM 1 SMC which includes the TDMA reference station which produces the TDMA frame and switching unit, which in turn conducts the signalling procedure through the common signalling channel. The switching unit also gathers information for billing and statistics.

Ad-hoc facilities for E.S.V.A. check the earth stations' compliance with the mandatory requirements for accessing the system, and perform ad-hoc tests in case of malfunction or claims by lessees. Such facilities may also be used to perform in-orbit acceptance and/or verification tests of the spacecraft.

Finally, the lease capacity monitoring stations record the use of capacity, and ensure that transmissions are within specified limits to avoid interference in adjacent transponders and/or satellites. They use the same receive facilities as those of the E.S.V.A. and I.O.T. functions.

5. CONCLUSIONS

The first EUTELSAT space segment was conceived as a support to the European terrestrial network. The development of the space segment has taken place at a time when demand for in-orbit capacity is booming and there is a high potential for profitable exploitation of new markets. The utilization of the EUTELSAT space segment has been reconsidered to meet the emerging demand so as to provide a tool for testing market sensitivity to new satellite communication services. The new utilization of the EUTELSAT space segment will provide Europe with an economically viable satellite communication system, which will benefit both the European users and industries.

Given the prevailing conditions on the continent, the above goal can only be achieved, through a strong cooperation between telecommunication entities and industries at a regional level. EUTELSAT is a valid example of how regional interests can only be satisfied by regional solutions.

References:

- "Le système régional européen ECS et ses répercussions sur la planification du réseau européen de télécommunications" - J. Domingo - Journal des Télécommunications Vol. 47 - 11/1980
- "A satellite system for the 80's" - A. Caruso & H. Billig - 33rd International Astronautical Congress - Paris-Sept. 82

FIG. 1. FC - SMS

UP-LINK BAND 12 - 12.08 GHz

DOWN-LINK BAND 12.5 - 12.56 GHz

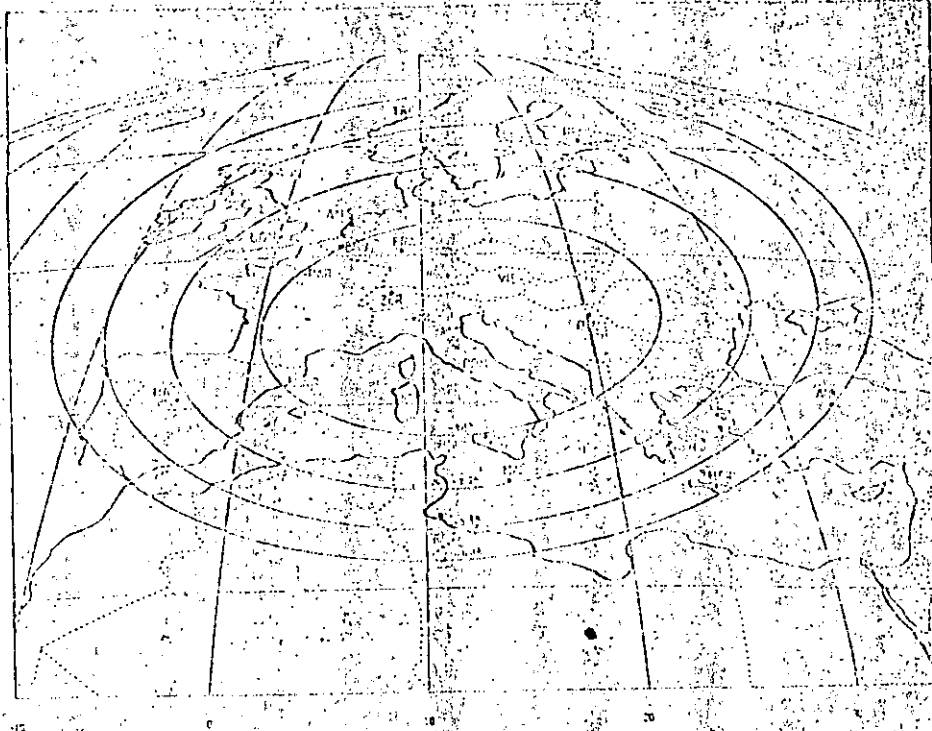


FIG. 2
TELECOM 1
- SMS

UP-LINK BAND
14 - 14.35 GHz
DOWN-LINK BAND
12.5 - 12.7 GHz

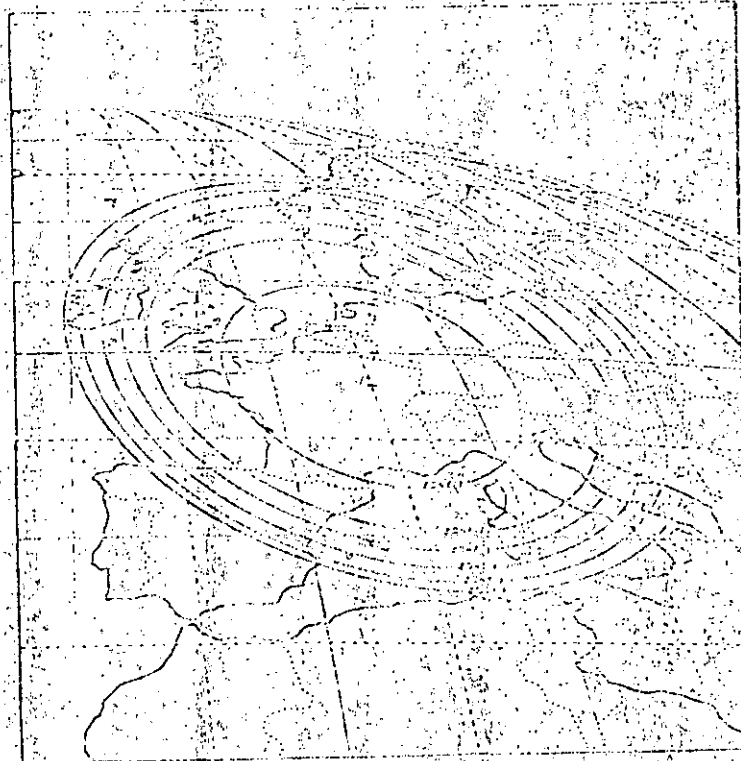


FIG. 3: TELEPHONY AND LEASE SERVICES

UP-LINK BAND 14 - 14.5 GHz
 DOWN-LINK BAND 10.95 - 11.92, 11.45 - 11.7 GHz

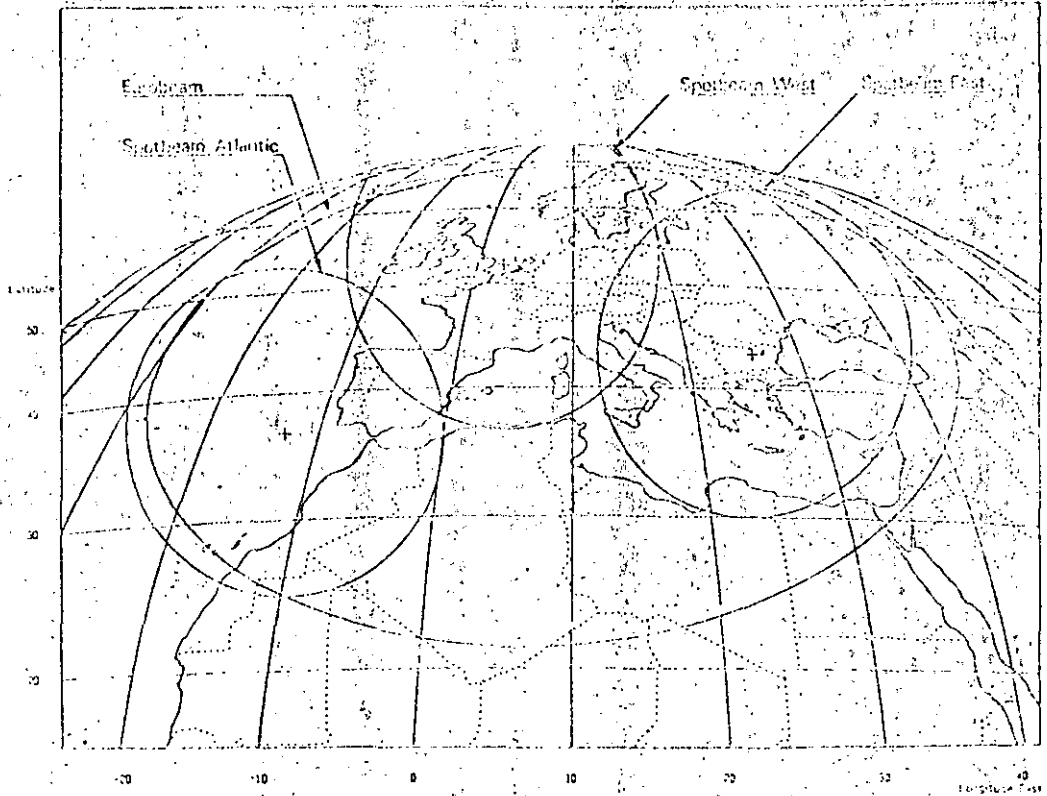
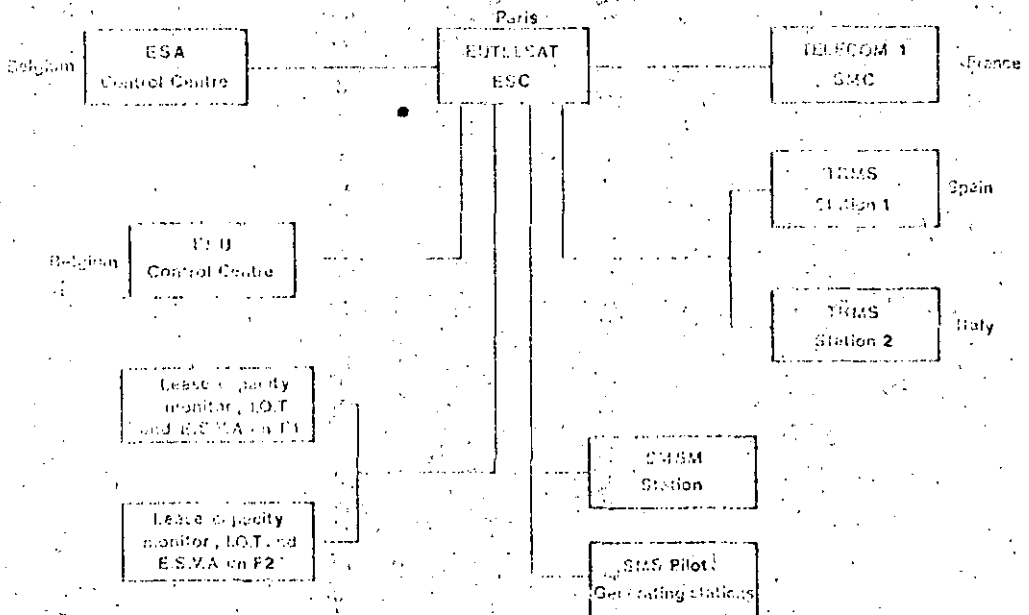


FIG. 4: MONITORING AND CONTROL NETWORK



437

FLEXIBLE SATELLITE COMMUNICATIONS :

THE ITALSAT EXAMPLE

432

POR S. TIRRO Y A. VERNUCCI

T E L E S P A Z I O

FLEXIBLE SATELLITE COMMUNICATIONS: THE ITALSAT EXAMPLE

by S. TIRRO, A. VERNUCCI

439

Telespazio S.p.A., via Bergamini 50, 00159 Rome, Italy.

ABSTRACT

Flexibility, that is the capability to allocate communications resources according to capacity demands, is the key requisite for domestic satellite systems, which grow in parallel with terrestrial network developments. Assignment on demand can be implemented in different modes, which differ one another mainly for the capacity assignment time, and at different levels, according to bundles dimensions.

This paper, after defining the various modes and levels of capacity assignment, describes the proposals made in the context of the specification study for Italsat, a 20/30 GHz experimental/pre-operational satellite system to be implemented by late eighties. Classical and new services are discussed separately.

INTRODUCTION

Satellite communications were initially used on intercontinental routes, because of high costs associated to satellite circuits. Due to technological developments, satellite systems are now able to compete with terrestrial means on much shorter distances, even on national basis. In the case of developing countries, satellites allow the fast realization of telecommunications networks, in the absence of pre-existing infrastructures. As to developed countries, satellites offer on the one hand the possibility to complement the existing terrestrial network for "classical services" (i.e. telephony and data) with a flexible alternative routing, and on the other hand the advantage to rapidly implement an additional telecommunications layer for "new services" (e.g. videoconferences, high speed facsimile, file transfer, etc.) which the ISDN will not be able to handle on a switched basis, due to high speed requirements (typically 20-30 Mbps).

Flexibility is the key requisite for a satellite system serving a developed country. Flexibility means the facility to allocate capacity resources according to individual stations requests.

"Cables in the sky" would hardly be justified, for classical services, if one takes into account that large capacities will shortly be available by means of optic fibers. As to new services, the requirement for flexibility arises from the relatively small number of circuits envisaged, so that assignment on demand is mainly needed for efficiency reasons.

DEFINITIONS

The general term "demand assignment" (DA) will be

used to indicate the process by which satellite capacity is distributed among system users, with the aim to follow, as close as possible, the capacity demand variations. DA can be implemented in the "commutation" (C), "breath" (B) and "permutation" (P) modes.

Commutation consists in allocating capacity on a "call" basis. As soon as a new call is placed, a circuit must be designated to satisfy that request (on-line mode). This circuit can be taken from a common pool of resources termed "bundle". Large bundles yield high circuits efficiency (Erlang per circuit). Terrestrial networks mainly use commutation techniques to achieve increased circuits efficiency at the expense of additional cost due to the switching function. A trade-off between the two aspects results in a minimum total cost. The number of circuits emerging from a terrestrial exchange is, today, fixed and it is determined on the basis of the blocking probability objective and the mean peak-hour traffic, averaged, in turn, over one year. Commutation in satellite networks offers another performance beyond that presented above for the terrestrial network. The multiple-access feature, typical of satellite systems, inherently infers the possibility of varying in time the share of capacity attributed to each earth station. The number of circuits emerging from an earth station may therefore not be fixed, if the commutation technique used foresees the variation in time of the actual earth station capacity. In this case the satellite system can also "track" the daily variation of the peak-hour traffic. This performance, which can be defined as "internal dynamic management", is useful in that it allows to maintain the blocking probability objective even when, due to unforeseeable events, the traffic distribution differs substantially from the average pattern. Commutation may not always be easily implemented in satellite systems for matters of circuits assignment time, especially when the variation of the actual earth station capacity is foreseen. As a matter of fact circuit assignment can be termed "commutation" if such operation is performed within a time interval consistent with the objectives set for the connection set-up delay. These objectives depend upon the particular service considered.

The "breath" mode of DA was conceived to offer the internal dynamic management performance, without imposing too stringent speed constraints upon the capacity assignment protocols of the satellite system. For the only purpose of following the daily variation of the peak-hour traffic, it would not be necessary to use commutation techniques. Ideally, if one would know a priori the traffic pattern of the following day, it would

be sufficient to perform a capacity redistribution once per day. In practice it will be necessary to let the system "breathe" much more frequently (several seconds or minutes), such as to be able to follow any unforeseen circuits demand. Breath operations therefore infer relatively slow capacity variations. It should be noted that the complexity of the breath mode is by far inferior to that of the commutation mode; one could consider, for instance, that the system management centre only needs the knowledge of the number of circuits actually "off-the-hook" at each station, for performing breath operations. The breath mode is clearly also adequate to cope with foreseeable variations of the traffic pattern. However, such variations can be handled by a simpler capacity reassignment technique termed "permutation". Permutation consists in allocating resources to individual stations on pre-programmed basis (off-line mode), in order to cope with medium and long-term traffic pattern variations. Permutation facilities are already implemented in operational TDMA systems (e.g. Intelsat) and they are normally referred to as "traffic rearrangement". Permutation operations are only performed occasionally; relevant protocols are therefore not critical timewise. Furthermore, no on-line processing is required at the system control station, as the update time plans are determined independently of traffic measurements.

From the above discussion it is clear that a flexible satellite system may incorporate all the DA modes presented, with an apportionment such as to yield the best trade-off between system complexity and performance.

As to the flexibility level offered by DA, three levels can be identified, if one considers a multibeam SS-TDMA system, i.e. variable destination (VD), variable origin (VO) and variable window (VW).

Variable destination is the case where, in a fixed-length multidestination burst, it is possible to vary the proportion of circuits destined to each receiving station. Variable origin is the case where the length of bursts can be made variable according to individual traffic requests. However, the sum of the lengths of the bursts contained in a single transponder-to-transponder connection (window) shall remain constant at any time. Variable window refers to the case where the length of windows can be made variable, under the obvious constraint that the sum of the windows lengths shall remain constant (transponder capacity).

It should be noted the VD, VO, and VW levels can be performed either in the C, or B, or P modes.

In practice combinations of the above levels are used; in the Italsat case, for instance, it was determined that the only realistic configurations are: VD, (VD+VO), and (VD+VO+VW).

THE ITALSAT CASE

Italsat is a 20/30 GHz experimental/pre-operational satellite designed to offer flexible communications within the Italian territory. In the late eighties, only the 6-spot SS-TDMA payload will be herein considered; however three national-coverage transponders will also be available on the spacecraft. The multibeam payload will be used to carry both classical services (including $n \times 64$ Kbps data) and new services. Integration between these two kinds of services is such that both transponders and earth stations will be shared for the two applications, but separate resources (i.e. portions of the TDMA frame) are allocated to them.

The Italsat system is presently in the system

specifications phase, which is expected to be over by mid-84, when an RFP to industry will be issued. The main system characteristics are:

speed: 147.436 Mbps

frame length: 32 ms

On-board regeneration and re-clocking are envisaged, even though no further on-board signal processing is foreseen. The use of time-switching stages on-board was considered not to be consistent with the experimental/pre-operational nature of the Italsat system. In the following, the present definition status of the DA techniques is outlined, separately discussing the capacity allocation procedures for classical and new services.

Classical services

A 32 Kbps telephone channel (ADPCM) requires 212 symbols (satellite channel). There are 4608 satellite channels in a TDMA frame. DA at VD level can be performed in the C mode without inducing significant complexity in the satellite system. Present Intelsat-type multidestination DNI or DSI terrestrial interfaces can be adapted, with some modifications at the receive side, to DA operation. In particular, the receive side IC/TC map shall be varied on the basis of information derived from telephone signalling. No dedicated service channels for DA purposes are required. At the transmit side, the terrestrial interface operates in a transparent fashion, provided that the bundle of circuits offered to it by the CT only contains circuits destined to the addressees of the multidestination burst. This means that each individual IC will carry circuits destined to different stations, at different times. In order to achieve maximum circuits efficiency, large bundles must be used; for this reason it is envisaged that all the receiving stations lying in the destination spot will be served by a single bundle (station-to-spot configuration). Therefore the number of destination of the multidestination burst will be equal to the number of stations of the down-link spot. Ideally a single station-to-spot burst may be used to save on the number of preambles and therefore to increase frame efficiency. In practice this will not be possible because of the characteristics of the time slot assignment algorithm (Ito algorithm, modified by Inukai). This algorithm allows to obtain a nominal 100% efficiency, as the ratio of the "critical line" to the "switching plan length", but has the disadvantage of breaking the spot-to-spot connection intervals (windows) into several periods. This feature has two main consequences:

a certain number of bursts must be splitted into two parts, because of the time discontinuity of windows. However, due to the fact that, for a 6 spot system, a maximum of 26 states of the on-board matrix can occur (Inukai theorem), the number of windows relevant to each up-link spot cannot be higher than 26. Taking into account that the minimum number of windows required for full system connectivity is 6, it becomes evident that 20 splittings will occur in the worst case. This may require up to 20 additional preambles. In practice, it will be necessary to foresee the increase of the length of each state by one satellite channel, due to the fact that the actual number of preambles (each rounded to one satellite channel) cannot be foreseen a priori. For the Italsat case, this only leads to a 0.5% efficiency loss.

It is appropriate to depart from the Intelsat concept, where a terrestrial interface module (TIM) can only generate one sub-burst. This window splitting problem would infer a larger number of DSI or DMI units, if the Intelsat approach is pursued. In the Italsat case, each TIM will be able to generate more than one sub-burst. It should be noted that splitting a station-to-spot burst into two bursts does not have any impact on burst efficiency, provided that all the receiving earth stations can receive both bursts.

As to frame efficiency, a worst-case 98% figure is achievable for a system with about 90 earth stations. The above figure does not include the contribution due to the non-unity fill factor in each spot, arising from the fact that the traffic actually offered to each transponder is generally lower than the maximum capacity offered by the transponder itself. It is reasoned that this contribution is dominant in the calculation of the overall system utilization efficiency. However, the use of the Ito/Inukai algorithm has the additional advantage that its efficiency performance is independent of the transponders fill factor.

DA at VO and VW levels in the C mode are more critical timewise, because of the additional time needed for the execution of protocols intended to vary the capacity originated by individual stations. The CCITT recommendation concerning the telephone connections set-up delay (Rec. Q504 amended by doc. P5-E) indicates recommended maximum values for the exchange call set-up delay, the through connection delay and the exchange call release delay, for a total of 800 ms. Even in the VD case discussed before, it will not be possible to meet this figure, but the range of values obtained for this case (2850-3000 ms) may still be considered acceptable, if one takes into account the inherent delay of the satellite links and the use of a Signalling-Transfer-Point (STP) structure.

In the VO and VW cases, it may still be possible to achieve values close to those relevant to the VD case, but only if the capacity reassignment operations, affecting the earth stations and satellite time plans are done in a "direct" and "differential" fashion.

"Direct" means that no check is done, before implementing the new time plan, that the re-assignment information was received correctly at the earth stations and/or the satellite. This in order to avoid the triplication (at least) of the duration of the capacity assignment protocol. "Differential" means that the information circulating in the system only concerns the capacity variations, whilst no information is distributed for what concerns the part of capacity which remains "untouched". The only practical way to do this is to use a burst structure such that the length of each burst is the same. In particular, a single-channel-per-burst solution would be attractive from this viewpoint. Following the request of one circuit, a station would be assigned with an additional burst, which would be placed at a convenient part of the frame. There is no proper "time plan" to be developed (neither for the earth stations nor for the satellite). In case of failures in the assignment protocol, a minimal risk would exist, because only two circuits would be involved (the interfering and the interfered ones). Unfortunately the frame efficiency of such a solution is low (60-65%). Another fixed burst length case is that in which each burst carries more than one channel. In these conditions the assignment efficiency would decrease (a few circuits would be assigned for a single circuit request) and the risks associated with the assignment protocols would increase,

but a higher frame efficiency can be obtained. Solutions with bursts of variable length cannot be utilized for the VO and VW cases in the C mode, because of the exceedingly high time required for capacity assignment operations. As a matter of fact, the variation of the capacity of a few bursts may imply a completely new time plan.

As to DA in B mode, there is no need of the B mode for the VD level, as it can be conveniently performed in the C mode, as explained above. VO and VW levels can be implemented in the B mode with any burst structure, because there is no stringent time performance to be met. However the fixed burst length solution has still the advantage to be "differential" by its nature and to give minimal risks. This is even more true if one considers that, due to the availability of time, there will be the possibility to check the correct reception of assignment information. In case of variable burst length, the more dangerous problem arises from the fact that, due to occasional severe fading, occurring at 20 GHz, a traffic station may remain "blind" for certain periods, then losing the capacity reassignment information transmitted by the control station. It should be noted that, following a new set of requests by traffic stations, the control station must, in the variable burst length solution, develop a new time plan for all the earth station (VO level) and for the satellite (VW level), as it is very likely that all (or most of) bursts will be displaced in the frame and varied in length. A station losing the re-assignment information may therefore cause severe interference to other bursts. The philosophy around which the Italsat assignment protocols will be built is the following:

- when the control station does not receive properly the capacity request channel transmitted by a traffic station, it freezes the capacity allocation to that station, but it is still allowed to displace the position of its bursts, such as to be free to develop up-dated time plans.

- when a traffic station realizes that the atmospheric attenuation exceeds a threshold value, it locally takes the decision to cease the transmission of its bursts. This does not cause harm, as the BER on traffic circuits is, in these conditions, certainly higher than the "circuit availability" threshold.

- the station will only be allowed to re-enter the frame, once propagation conditions become normal.

The development of protocols is being done presently; at this stage, however, it cannot be excluded that a fixed burst length solution with several channels per burst may yield, in the end, superior performance. For this reason the on-board matrix controller was designed in such a way to allow the adoption of both frame structures.

As to the P mode, all levels (VD, VO and VW) will be implemented, for maximum system flexibility.

An analysis was carried out to determine the advantages obtained in terms of circuit efficiency, with the various levels of DA, in the C mode. It was concluded that VW offers little efficiency increase with respect to the VO level, whilst this last level gives a 10 to 15% efficiency increase with respect to the VD level. Furthermore it was observed that the efficiency appropriate to the VO level in the B mode can be made quite close to that of the VO level in the C mode, if capacity reassignment operations are done frequently, and foreseeing a variable DSI gain technique, which allows to "absorb" traffic peaks arising in the period between two subsequent

capacity allocations.

In the end it was concluded to implement the VD level in the C mode and the VO and VW levels in the B mode. P mode will exist at all levels.

New services

Videoconferences is certainly the most complex among the new services implemented by Italsat, and it is therefore the one which deserves more thorough consideration. This service will be implemented on reservation basis, with waiting times of the order of 1-2 days. It was estimated that 25% of the traffic volume will concern more than two studios and that the average duration of a videoconference is 1.5 hours.

One of the most challenging aspects of this service is the ability to perform multipoint videoconferences with minimal capacity requirements. With global coverage satellites, the multipoint feature can be implemented easily. In a multibeam environment there are two basic ways to implement multipoint videoconferences, i.e. permanent interconnection or dynamic interconnection.

In the first case each of the n studios is permanently connected to the remaining $(n-1)$ studios for the duration of the videoconference. This is normally done by the repetition technique, according to which each station repeats $(n-1)$ times its video signal in $(n-1)$ time slots of the frame (worst-case). It could be possible to reduce the up-link capacity requirement, by envisaging that the on-board matrix operates in the broadcast mode, so that the same up-link signal can be distributed to several spots in the down link. This last solution, however, introduces dissymmetry in capacity utilization and it is therefore not very attractive.

Dynamic interconnection means that each studio only receives the video signal from the studio which has got the floor, whilst the actual speaker "sees" the previous speaker. This solution requires real-time variations of the connections, operated by the on-board matrix. The number of videoconference channels required is n , where n is the number of studios participating in the videoconference. The on-board matrix must have the capability to broadcast the video channel, which is transmitted by different stations alternately. To do this, the time slot broadcasted to the down links must be connected each time to the appropriate up-link. This could be done by changing the on-board matrix time plan, at least partially, each time a new studio takes the floor. A simpler and safer way to implement the dynamic interconnection feature is the use of an on-board matrix capable of being operated in the so called "gathering mode", by which it is possible to select the transmitting up-link, without changing the time plan content. The videoconference chairman will be the responsible for selecting up links, by remote command. The worst-case situation will occur if all the participating studios are located in different spots. If two stations lie in the same spot, the selection will be done simply enabling only one station to transmit the videoconference burst, and will not require any command to the satellite. In the Italsat case, it was estimated that the efficiency gain achievable with the dynamic interconnection technique is about 1.5, with respect to the repetition technique. This figure already takes into account the estimated probability of having multipoint videoconferences involving n studios. It is interesting to note that the efficiency achievable in these conditions is only 1.15 times lower than that which can be obtained in a global beam configuration. Even though, due to the relatively low percentage of expected multipoint videoconferences,

441 efficiency gain is not so high, it was considered appropriate to foresee the possibility to experiment the dynamic interconnection feature, in view of the experimental nature of Italsat.

As to the frame structure, the single-channel-per-burst solution was adopted because it provides a good frame efficiency (the length of a single videoconference burst is about 65 times the length of a telephone satellite channel), including the preamble and at the same time it can be handled very conveniently from the time plan viewpoint. As mentioned before, new services will occupy a dedicated part of the frame, which will be common to all transponders. This is because videoconference channels reassignments will only take place twice per hour, whilst the "breath" of telephony bursts will be performed on a much more frequent basis. It would therefore be difficult to integrate the two kinds of services to the extent that common capacity can be shared. This solution has the clear shortcoming that, if the ratio between the telephone and new services traffic is not the same in all the spots, it would not be possible to make maximum use of the capacity offered by the satellite. From the operational viewpoint, it is desirable to have the possibility to perform partial changes of the on-board time plan, so that it would be feasible to vary the capacity allocations on the telephony part of the frame, without touching the videoconference part (and viceversa).

As to DA levels, the expected videoconference traffic is rather small and reasonable efficiency can only be obtained with (VD+VO+VW). In practice this means that each time a new conference has to be established, appropriate time slots have to be allocated on the on-board matrix. Earth stations must then transmit their bursts in the assigned time slots. The establishment of a new videoconference shall not cause any nuisance to the videoconferences currently in act; in this respect the use of the single-channel-per-burst structure greatly simplifies assignment operations, due to its "differential" nature.

THE ON-BOARD MATRIX CONTROLLER

Italsat will be equipped with a 6×6 baseband switching matrix. The matrix controller is designed such as to allow both the variable-length and the fixed-length burst structures for telephony, and the fixed-length burst structure for special services. Furthermore it allows independent control of the telephony and new services parts of the frame, and the gathering mode for videoconferences.

The matrix controller will be equipped with two memories which store the content of the current and the new time plans respectively. Each memory will be able to store 1024 states of the matrix, each state having a resolution of one satellite channel. The number of states is sufficient to cover any traffic situation: for telephony only, 26 states would be required in the variable burst length case and a maximum (if no new services are implemented) of about 900 states in the fixed burst length case, with 4 channels per burst. Each state is identified by its starting instant, its configuration (i.e. the pattern of connections between inputs and outputs) and by an additional bit which declares the state as "activated" or "not activated". Even though up to 1024 states can be stored on-board, the actual time plan will only consist of the ordered sequence of the states declared "activated". The actual number of states in the time plan can therefore be made variable, at will. It will be possible to address a single state and change it.

parameters. Obviously, the change of the complete time plan will require the sequential addressing of all the activated states.

The link between the control station and the satellite for transferring the time plan information will be such that it will be possible to change 26 states in a few tenths of seconds. This only requires a bit-rate of the order of 100 bps. In the fixed-burst length case, it is not necessary to change the whole time plan, due to the "differential" working mode. Required variations are expected to be performed in periods comparable to those of the other solution. It should be noted that the gathering mode is easily implemented by designating a certain number of states having the same starting instant and differing one another for the selected up-link. Only one of these states will be declared "activated" at any one time, according to the videoconference chairman instructions.

CONCLUSIONS

The Italsat system is designed to offer, at the same time, advantages arising from the adoption of DA techniques and from the spot beam coverage. The price to be paid for this integration is an increased complexity with respect to systems offering the DA feature with global coverage. However, the use of the "breath" mode of DA should limit substantially this complexity increase. Italsat will be followed by an operational system (90ies) where national beam and spot beam transponders will be integrated into a common payload.

443

ITALSAT : THE ITALIAN PLAN

POR ROBERTO DEL PAPA

443

Consorzio Per Sistemi Di

Telecomunicazioni via Satelliti

444

Italsat: The Italian Plan

444

By Dr. Roberto Del Papa
 Consorzio Per Sistemi Di
 Telecomunicazioni via Satelliti

Italian manufacturers and governmental authorities seem to be more and more conscious of the importance of space. Debates, new proposals, planning of activities and cautious evaluation of aerospace investments, involving a rich participation of scientists, are becoming more and more frequent in Italy. However, this interest in space activities, and Italian industry's consideration of limited resource availability, is not a new development. As early as 1978, scientists, industrialists and government representatives began to contend that the only way to successfully implement some of Italy's proposals and plans for space was to coordinate at the national level.

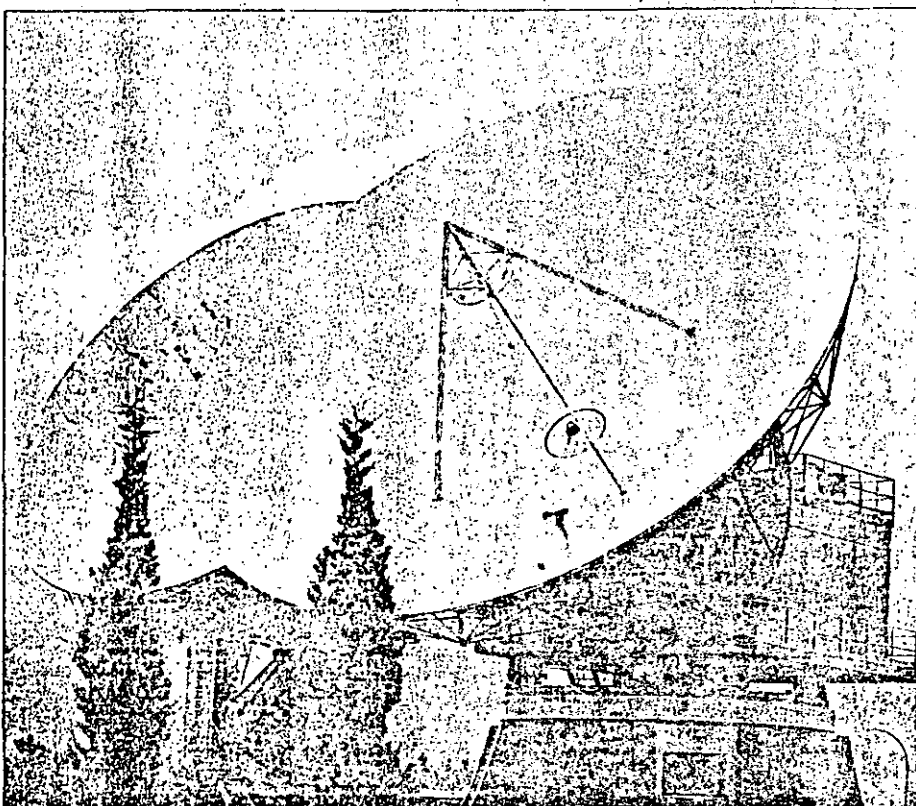
National Space Plan

In 1979, the Italian National Space Plan (NSP) was formulated. The Plan targeted areas where Italy would concentrate its efforts and estimated the economic and human resources required to succeed. The Plan also evaluated expertise in fields related to aerospace in 1979, then at the beginning of 1982, was revised.

Italian participation in ESA programs, telecommunications satellite construction projects with Intelsat, the construction of the Kenya launch base dedicated to aerospace research (CRA) and the most recent success in the construction and launch of one of a series of scientific satellites, SIRIO (operating since 1978 and conducting propagation and communication experiments in the 18/11 GHz band), considerably enhanced Italy's reservoir of experience. This made it possible to plan Italian involvement in space activities for a five year period from 1982 to 1986. The themes of the updated NSP are:

- Scientific programs;
- Technological programs.

The first group of programs is focused on advanced space research. The milestones for these scientific projects are satellite payloads dedicated to several research fields. These



Sirio: experimental earth station (Fucino, Italy).

are expected to be boarded in space vehicles by 1986. These programs are coordinated and, where possible integrated, with international scientific programs (Spacelab, Space Telescope, Exosat, Hypparcos). It is hoped that the implementation of these scientific programs will activate applied research and technology activities throughout Italy, stimulating new developments and products from Italian manufacturers.

The second NSP theme — technological programs — covers a diversity of applied fields, including space propulsion (Iris), tethered satellite systems (TSS), X astronomy (SAX & OOX), space geodesy, remote sensing, and finally, satellite telecommunications. In keeping with the international trend of naming satellite programs

"something...sat," the Italian Satellite Communications program is called "Italsat."

Italsat

The objective of the satellite telecommunication part of the Italian NSP is to develop a 30/20 GHz, pre-operational, multibeam satellite for digital telephony. Multiservice experiments at 30/20 GHz and propagation experiments at 50/40 GHz will be performed using specific payloads on this same satellite.

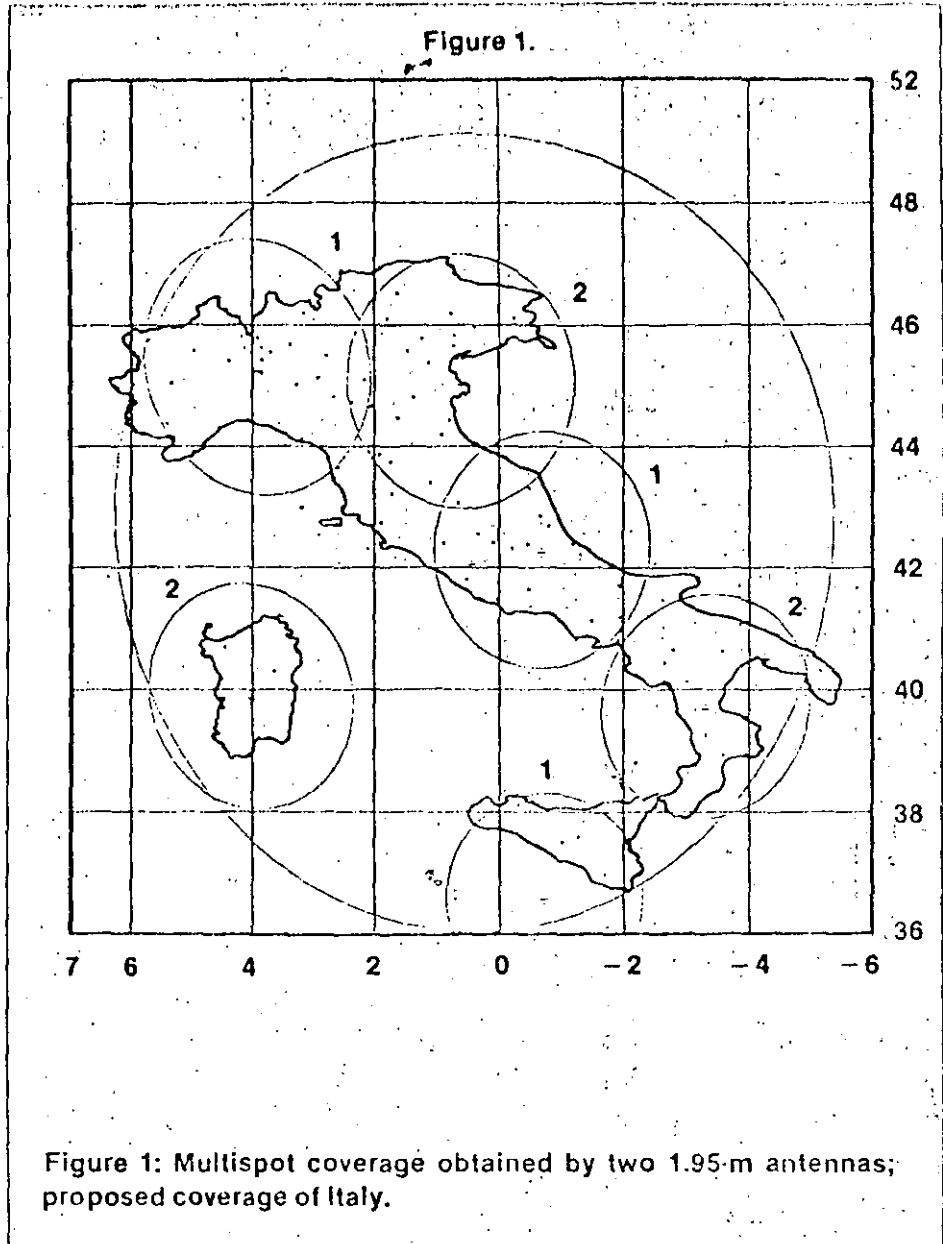
The Italsat program budget is about \$250 million (U.S.), part of which has already been used for the preliminary feasibility studies. The entire NSP budget amounts to approximately \$500 million (U.S.).

Table 1 summarizes the proposed Italsat payloads characteristics. The satellite itself will be developed by Italian manufacturers. Plans call for a 3-axis stabilized platform of the 1200-kg. class.

The communications system is expected to be based on Satellite Switching TDMA (SS/TDMA) techniques, with on-board regeneration capabilities of 120 megabits/second. This will enable the testing of an interconnected national network that is satellite-based.

The Italsat satellite launch is scheduled for 1985 or 1986 at the latest. By that time, three or four earth stations will be operational in Italy. These will be used for TT&C services and experimental purposes. The program is also expected to stimulate the Italian earth station industry to develop state-of-the-art equipment to meet the challenging requirements of such an advanced program. Small antennas (3-m diameter), very stringent profile tolerance and compatible with mounting specifications (probably roof mounted) will be required. Additionally, 30/20 GHz prime feed devices must be designed, tested and implemented. Earth station components, e.g. LNAs, HPAs, converters, must be designed to be compatible with the new and more demanding requirements of the first "preoperational" Italsat.

It is expected that an operational satellite will follow the preoperational experiment towards the end of the 1980s. The final Italian telecommunication network will use land lines and satellite circuits to satisfy actual demand. The final Italsat network configuration will probably use RF sensing multibeam antennas covering the territory with six spots as shown in the figure. 4



Italsat Payload Characteristics

MULTISPOT P/L (20/30 GHz)

- 6 Regenerative Redundant Transponders
- 2 Multibeam Antennas (3 Spots each)
- 2 RF Sensing Devices (+ 0.03° Pointing Error)
- 120 MB/S Bit Rate (QPSK)
- 20 W RF Power (TWT)
- 157 KG (Mass)
- 688 W (Power)

MULTISERVICE P/L (20/30 GHz)

- 3 Transparent Redundant Transponders
- 1 Body-Mounted Antenna (Italian Coverage)
- 25 MB/S (QPSK)
- 30 W RF Power (TWT)
- 33 KG (Mass)
- 382 W (Power)

PROPAGATION P/L (40/50 GHz)

- 2 Beacons
- European Coverage
- 1 W RF Power (Solid State)
- 11 KG (Mass)
- 65 W (Power)

TOTAL P/L MASS: 201 KG

TOTAL P/L POWER: 1,135 W

The ITALSAT programme

Franco MARCONICCHIO and Francesco VALDONI

Consiglio Nazionale Ricerche, Rome, Italy

The paper describes the experimental and pre operational Italsat Programme which has been conceived to prepare for implementation of a subsequent operational Italian domestic system. Such a system is expected to play an important role in the evolution of an Italian Integrated Services Digital Network (ISDN).

Keywords: Italian, domestic satellite, ISDN, millimetre wave, data services, wideband services

Franco Marconicchio, born in 1941, received the Electronic Engineer degree at the University of Rome, Italy in 1965. From 1965 to 1967 he attended a post graduate course in Aerospace Engineering. In 1969 he joined CNR: he had the responsibility of the attitude and orbital control of the SIRIO Project and in 1971 of the SIRIO telecommunication Payload. From 1976 to 1979 he was in charge of the national telecommunication activities and took part in the definition of the telecommunication program of the 1st Italian National Space Plan. Since 1980 he has been responsible for the management of the ITALSAT Programme.



Francesco Valdoni, born in 1938, received the Electronic Engineer doctor's degree at the University of Rome, Italy, in 1962. Till 1968 he was with the Fondazione Ugo Bordoni, in Rome, doing research on microwave circuits; after he taught radioscience and microwave communication at the University of Bologna, Italy, becoming full professor in 1975. On behalf of the Fondazione Ugo Bordoni, from 1968 to 1976 he was director of a national research programme on circular wave-

guide telecommunication systems, sponsored by Istituto Superiore P.T.; from 1977 to 1982 he was director of the Italian Research Project on Navigation Aids and Air Traffic Control, sponsored by Consiglio Nazionale delle Ricerche. Since 1980, he became scientific responsible for the telecommunication programmes of the Piano Spaziale Nazionale of the Consiglio Nazionale delle Ricerche; since 1982 he is with the II University of Rome, as electrical communication professor. Francesco Valdoni is a member of IEEE and AEL.

1. Introduction

In the near future with all telecommunication and telematic services performed by a telecommunication network, the Integrated Services Digital Network (ISDN) will be fully implemented. The evolution process from the present domestic analog network towards the ISDN structure could have three main phases.

In the present first phase, the telephone network development is made by superimposing a digital network to the existing analog one; in this way the network ability to provide data services with bit rates up to 64 kbps will be significantly increased.

In a second phase the digital network will have a larger penetration, but still with an integration at the 64 kbps level and the new wideband data services provided by dedicated networks.

In the last phase, with the completion of the digitalization process and the integration of services with bit rate higher than 64 kbps (probably making use of optical fibres in local areas), the ISDN structure will be completely implemented. A forecast for achievement of this target in the European region could be the beginning of the next century.

In this context, a domestic telecommunication satellite system could offer significant advantages in the evolution towards the ISDN. Due to its quick implementation, the demand for data services up to 64 kbps and wideband services could be more rapidly satisfied. Moreover, due to its flexibility, the size of trunks could actually match the demand as regards seasonal variations and the uncertain development of the new telematic services. As a further advantage, the satellite system could also be operated to back up the terrestrial network, particularly in the event of natural disasters:

This paper considers, in particular, the situation in Italy.

2. ITALSAT experimental-preoperational mission

In 1979, the Italian Government approved a national space research and development plan, the "Piano Spaziale Nazionale", whose main objective, among other important activities, was the design, construction and launch of an experimental domestic telecommunication satellite (ITALSAT). According to the national plan, this satellite should be "experimental with preoperational characteristics, for point-to-point connections by means of multiple beams in 20/30 GHz bands".

The choice of these bands has the disadvantage of high atmospheric attenuation, but, with the use of high gain antennas, the Italian coverage may be guaranteed by many separate spots. The access to the satellite will be SS-TDMA (Satellite Switched-Time Division Multiple Access), which is compatible with the use of multiple spot beams.

The onboard regeneration of the received signals offers the advantage of separating the uplink impairments from the downlink, also it avoids the onboard multipath problems and permits the independent equalization for the up and down links; it also allows the onboard generation of the reference unique word (RUW) for TDMA synchronization.

In addition, the baseband switching matrix will allow in the future the on board introduction of more advanced switching functions, with a consequent reduction of the investments in the terrestrial network and the possibility of simultaneous access to satellite from different bit-rates terminals.

These main features seem promising from the telecommunication mission point of view and will have the important role to better qualify the Italian know-how in the space telecommunication field.

The Italian Consiglio Nazionale delle Ricerche (CNR), which has the responsibility of managing the national space plan activities, is therefore progressing with the implementation of the ITALSAT mission which started at the beginning of 1981 with a phase A study.

In the study, the performances of a domestic operational satellite to operate in the '90s were examined. This in order to have a guideline in the definition of the experimental-preoperational

ITALSAT, to be launched in the '80s, able to anticipate the techniques and solutions that we can foresee for the future operational domestic satellite, as well as to verify the system from a technical and economical point of view.

ITALSAT is designed to transmit digital signals up to and above 64 kbps, either via a multispot regenerative payload or via a transparent global (Italian) coverage payload.

An experimental phase is foreseen in the first period of satellite orbital life to check the equipment performances and the communication system design. Depending on the achieved results, a pre-operational phase will follow. Therefore, the payload and overall system design will have to guarantee, as a design goal, a quality and availability for the various telecommunication services in accordance with the relevant CCIR and CCITT recommendations.

2.1. Payloads

The ITALSAT satellite is designed to carry onboard three payloads:

- a multibeam payload,
- a global Italian coverage payload,
- a propagation payload.

The multibeam payload includes two deployable transmitting/receiving multibeam antennas, each able to generate three beams. Italy will therefore be covered by 6 spots: 1. North-West, 2. North-East, 3. Center, 4. South, 5. Sicily, 6. Sardinia (see Fig. 1). The 3 dB beamwidth at 20 GHz is 0.495 degrees, which gives a coverage of 0.435 degrees due to a ± 0.03 degrees pointing accuracy, by means of RF sensors on the antennas (the guaranteed pointing accuracy will be ± 0.06 degrees, and ± 0.03 degrees must be considered a design goal). The beamwidth at 30 GHz is of course narrower than the one generated at 20 GHz; therefore the -3 dB coverage at 20 GHz becomes a -6 dB coverage at 30 GHz.

Each spot is served by a regenerative repeater, working at the speed of 147 Mbps, with a total capacity of 884 Mbps; interspot connectivity will be provided by a synchronous baseband switching matrix. The TDMA burst signals received onboard will be converted into continuous signals at the

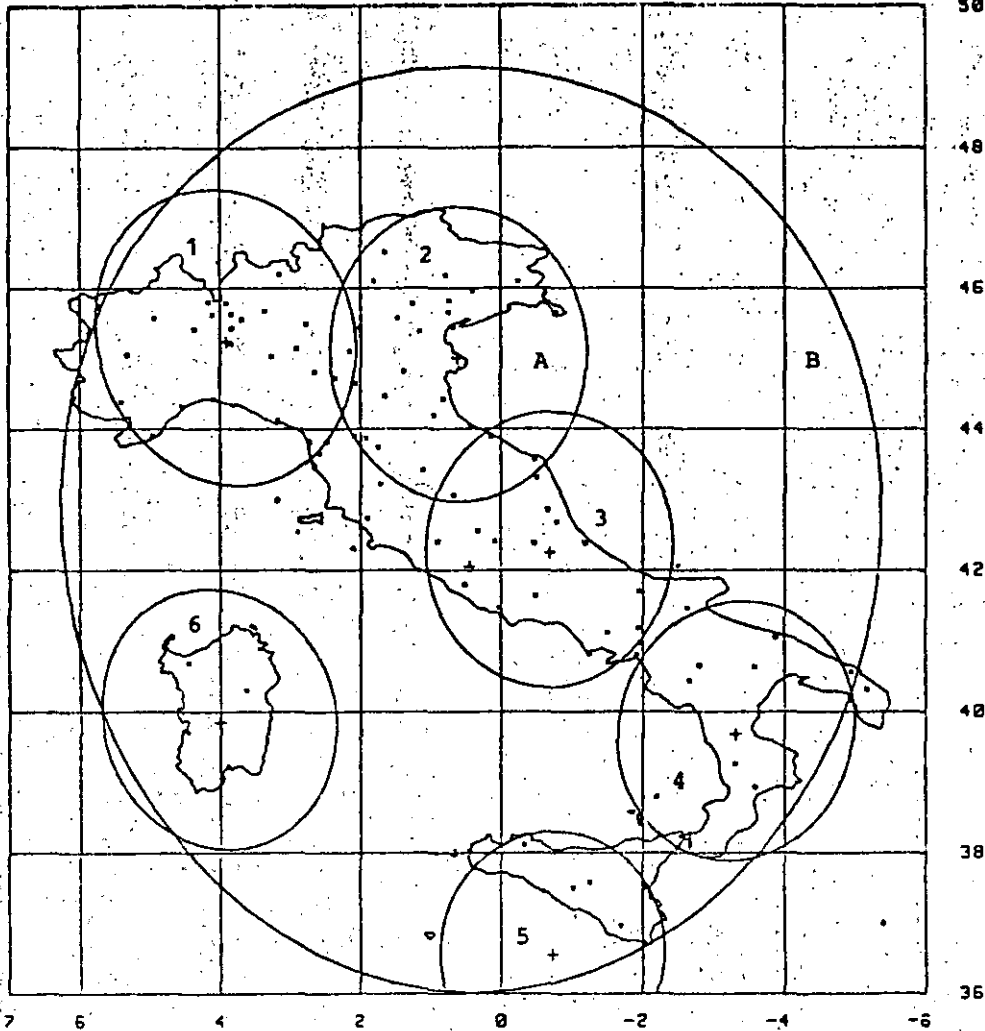


Fig. 1. A Multispot coverage; B. Global coverage.

output of the switching matrix.

The Beginning of Life (BOL) TWTA RF power is 20 W in sunlight and 8 W in eclipse and the End of Life (EOL) EIRP is 55.2 dBW. The total mass of the multibeam payload is 159 kg (9 transponders at BOL) and the required power is 664 W in sunlight and 463 W in eclipse (6 transponders of 8 W each).

The global coverage payload consists of three transparent redundant transponders, operating at 24.5 Mbps, with a total capacity of 73.5 Mbps. These transponders are connected to a body-mounted antenna with a ground coverage of 1.45

degrees at -3 dB (see Fig. 1). The antenna pointing accuracy is ± 0.18 degrees, due to the performance of the basic spacecraft attitude control system.

The BOL TWTA RF power is 20 W/8 W and the EOL EIRP is 47 dBW. The total mass of this payload is 49 kg (4 transponders at BOL) and the required power is 214 W in sunlight and 113 W in eclipse (3 transponders of 8 W each).

The propagation payload includes two beacon generators, one operating at 40 GHz and the other at 50 GHz, both with European coverage. The output power of each beacon generator is 1 W,

Table 1
Payloads characteristics

Payloads	Frequency (GHz)	No. of antennas	No. of active transponders (EOL)	RF power (W)	Power consum. (W)	Mass (kg)
Multibeams Italian coverage	20/30	2 deploy.	6	20	664	159
Propagation experiment	20/30	1 fixed	3	20	214	49
Payload	40/50	2 fixed	2 beacons	1	43	11
Ancillary equipment	-	-	-	-	95	16
Total					1016	235

Table 2
Antennas characteristics

Payloads	Diameter (m)	Beamwidth - 3dB (degrees)	Pointing error (degrees)	EIRP (dBW) (EOL)	No. of spots or coverage
Multibeam	1.95	0.495	±0.06	55.2	3
Global coverage	-	1.81	±0.18	47	Italy
Propagation experiment	-	3	±0.18	32.7 (40 GHz) 29 (50 GHz)	Europe

obtained by IMPATT solid state amplifiers.

The 40 GHz beacon is circularly polarized and phase-modulated at 500 MHz, in order to obtain a triplet of coherent frequencies. The 50 GHz beacon is linearly polarized, with polarization switching.

The total mass of the propagation payload is 11.4 kg and the required power is 43 W. The propagation payload is not operating in eclipse.

Payloads total mass is 235 kg and the required power is 1016 W in sunlight and 667 W in eclipse. These values includes payload common equipments. Payloads main characteristics are summarized in Tables 1 and 2.

2.2. Basic spacecraft

The following main requirements have been specified for the basic spacecraft design:

- the spacecraft dimensions and mass to be compatible with both STS-PAM/D II and ARIANE/4 launch vehicles;
- maximum capabilities in terms of mass available for the payloads;

- maximum reuse of the existing qualified components.

The resulting design approach is the selection of a three-axis stabilized satellite utilizing the liquid unified propulsion system for ABM + RCS (Apogee Boost Motor + Reaction Control System). This approach has as main advantage a significant flexibility in the spacecraft design which will allow to accept different missions and to match future launcher improved performances.

The electrical power required by satellite and payloads is about 1400 W at the end of the five years lifetime and a Ni-H₂ battery package of 1000 W will supply the power during the eclipses.

The selected configuration for the attitude control system is based on two skewed momentum wheels on pitch axis and one reaction wheel aligned with yaw axis. The predicted performances are: ± 0.13 degrees in N/S and E/W and ± 0.27 degrees in yaw. They are compatible with the pointing accuracy required by the body-mounted antenna.

The basic spacecraft and payload reliability at

Table 3
Spacecraft main characteristics

Mass	at launch	1410 kg ARIANE
	at launch satellite	1570 kg STS PAM/D II
	dry mass	735 kg
	payload mass	220 kg
Orbit	geostationary	13° E
Lifetime		5 years
Spacecraft reliability		0.80
Pointing accuracy	- for body mounted antennas	±0.13° N-S ±0.13° E-W 0.18° half-cone ±0.27° yaw
	- for deployable antennas with RF sensing	±0.05° N-S ±0.03° E-W 0.06° half-cone ±0.27° yaw
TT&C	in S band	
Solar array	2 wings × 4 panels each	1400 W (EOL solstice)
Batteries	Ni-H ₂	1000 W
Stabilization	3-axis	
Propulsion system	Bipropellant, Unified for ABM and RCS	

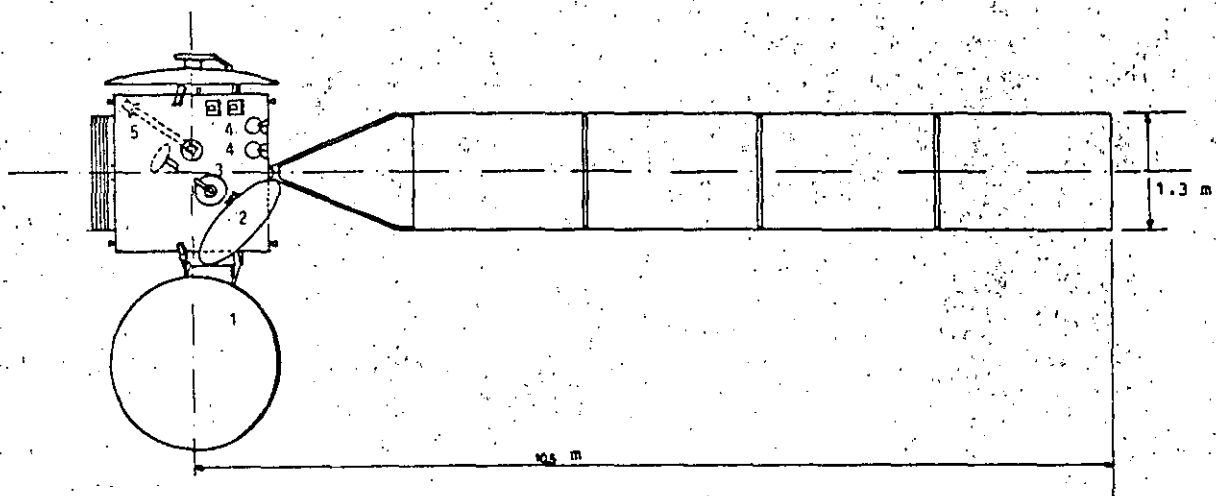


Fig. 2. ITALSAT configuration; 1. Multibeam antenna, 2. Global coverage antenna, 3. Global coverage subreflector, 4. Propagation experiment antennas, 5. TT & C antenna.

Table 4
Ground stations main characteristics

Italian climatic zones	Rain intensity exceeded for 0.01%	Ground stations			
		Multispot 147 Mbps		Global 24.5 Mbps	
		Antenna diameter (m)	HPA power (W)	Antenna diameter (m)	HPA power (W)
1	65 mm/h	5	200	5	200
2	45 mm/h	5	50	5	2 × 50
3	25 mm/h	3.4	50	3.4	2 × 50

the end of the lifetime is 0.80 and 0.85 respectively.

In Table 3 the spacecraft main characteristics are indicated and Fig. 2 shows a sketch of the satellite.

2.3. Ground segment

Due to Italy's different climatic zones, the telecommunication ground stations design is based on two different TWTA power levels and antenna diameters. The combination of these two parameters allows to meet the requirements of the RF links in each of the three climatic areas.

The worst situation is for zone 1 (where rain intensity exceeds 65 mm/h for 0.01% of the time) in which for the 147 and 24.5 Mbps signals a 5 m antenna and 200 W TWT are required. For zone 2 ($R = 45$ mm/h; $P = 0.01\%$) the solution was found with a 5 m antenna and 50 W TWT for a multi-beam payload and a parallel of 2 × 50 W TWTs for the global payload; for zone 3 ($R = 25$ mm/h; $P = 0.01\%$) the required RF power is the same as for zone 2 but with a 3.4 m antenna diameter.

The ground station design is based on a unavailability figure of 4×10^{-4} . The ground station main characteristics are shown in Table 4.

2.4. Programme key events

The phase A was completed in the first quarter of 1982. The phase B started in June 1982 and is expected to be completed in the third quarter of 1983. In 1984 CNR plan to start the phase C/D for a launch in the last quarter of 1987.

3. Conclusions

An operational domestic satellite telecommunication system could be very beneficial to the rapid implementation of the future ISDN. However, the complexity of the satellite payload as well as the design of the earth segment will require a significant effort in view of an economical and technical optimization of the overall system. This is the purpose of the experimental-preoperational ITALSAT programme.

446

TELECOM 1 - A NATIONAL SATELLITE

COMMUNICATION SYSTEM

1146

POR D. LOMBARD, F. RANCY Y D. ROUFFET

C N E T

TELECOM 1: A NATIONAL ORBITATION SATELLITE
FOR DOMESTIC AND BUSINESS SERVICES

by D. LOUARD, P. BÉRY and J. ROUFFET

Centre National d'Études des Télécommunications
38, 40, rue du Général Leclerc
92131 Issy-les-Moulineaux, FRANCE

ABSTRACT

In February 1979, the French Administration decided to establish the TELECOM 1 national communication satellite network.

The objectives of the TELECOM 1 program are to provide a flexible digital communication service available to business, community and government video services, telecommunication services, as well as to increase the communication capabilities to and from French overseas departments.

TELECOM 1 satellites will be characterized by two frequency bands (14/12 and 6/4 GHz), operational in the geostationary orbit. The new service will be provided through low earth orbit earth stations interconnected via a multiplexed digital multiplex access system.

1. INTRODUCTION

The French Administration decided in February 1979 to establish the TELECOM 1 domestic satellite network. The first satellite will be launched by the middle of 1982 by the European launch vehicle. The objectives of the TELECOM 1 program are:

- to provide a business service to geographically scattered firms for the transmission of internal data, microphone and video signals in the 14/12 GHz band;

- to provide a video transmission and voice service between a reporting station and a number of earth stations installed on the roof of production halls using the 14/12 GHz band;

- to provide telephone and television services between mainland and overseas French departments using the 6/4 GHz band.

The aim of this paper is to describe the satellite payload and the earth segment of the TELECOM 1 system.

2. BUSINESS SERVICES AND VIDEO TRANSMISSION

2.1 General

Small earth stations, located at the customer's premises, provide a mobile convenient access to a satellite network. Direct connection to every user via satellite provides a high degree of flexibility to the domestic network and is particularly attractive for data traffic. The necessary satellite antenna beam size is small and the link budget permits the use of 3.5 meter earth station antennas in conjunction with 20 SW/beam antennas (14dB) in the satellite.

2.2 Business services

TELECOM 1 will offer the following point-to-point services:

- data transmission, including high speed computer communication. The bit rates provided will range from 2.4 kbit/s to 2 Mbit/s;
- videoconferencing, video transmission of relay video signals. This service is intended as a partial replacement of business travel;
- high speed facsimile;
- text and data base transfer;
- photographic and press newspaper page distribution;
- telephone links between the various locations of geographically scattered firms.

In addition, the above mentioned services will also be available in a point-to-multipoint or broadcast mode of operation.

TELECOM 1 may also be used to fulfill the requirements of existing public data networks (TRANSMIC or TRANSPAC). In addition, error correction, encoding and encryption facilities will be provided to the subscribers when a high degree of reliability or privacy is required.

The traffic forecast for 1980 has been evaluated to 125 Mbit/s, which translates into a requirement of five transponders at this point in

in time, assuming a bit rate of 25 Mbit/s (see section 2.8).

2.3 Videotransmission service

Satellite communications can promote point-to-multipoint videotransmission of selected events to halls or theaters for community viewing, provided the costs of the receive antenna and associated equipments are reasonable. Using a 20 W satellite TWT, the required quality can be achieved over the national territory with 1.8 to 2.3 meter antennas.

On TELECOM 1, one transponder (identical to the business service transponder) is dedicated to videotransmission. In all, TELECOM 1 will be equipped with six 14/12 GHz transponders. Each transponder will transmit, in accordance with the demand, either the 25 Mbit/s data traffic for business service or one video channel for videotransmission. The videotransmission service will also incorporate a voice return channel, thus favoring the participation of the audience to the event.

2.4 Frequency bands selection

The proper development of the kind of services described above requires freedom from interference throughout the national territory. In the ITU Region 1, the 12.5-12.75 GHz band is allocated exclusively to the fixed satellite service. This band, intended for the down-link, is sufficiently wide to transmit the 125 Mbit/s and is sufficiently close to the 10.95-11.7 GHz fixed satellite service band to allow the use of the well-developed technology of the latter band. The up-link will be in the 14-14.25 frequency band which is not used for terrestrial fixed service.

2.5 The 14/12 GHz satellite payload

The 14/12 GHz payload comprises six 36 MHz transponders designed around 20 W travelling wave tubes (TWT's). The block diagram is given in figure 1. The receiver is common to the six transponders and includes a single frequency conversion, which is simpler (and therefore more reliable) than a double conversion receiver. Input and output multiplexers are based on available techniques. The high power amplifiers use a 12 GHz 20 W TWT derived from the 11 GHz Thomson-CSF tube currently operating in OAS and INTELSAT V. The design also includes one redundant TWT for each pair of transponders and one redundant receiver common to the six transponders. The national coverage (figure 2) is obtained with a high-gain transmit and receive antenna (about 37 dB at beam edge). This requirement corresponds to an antenna diameter of 0.8 m compatible with the ARIANE launch vehicle (maximum diameter of 2.18 m).

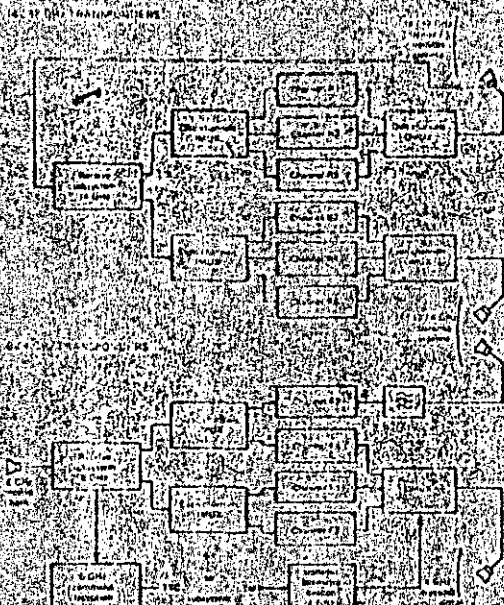


FIGURE 1. PAYLOAD DIAGRAM

The specified EIRP at beam edge is 47 dBW and the G/T of the satellite receive subsystem is 6.3 dB/K.

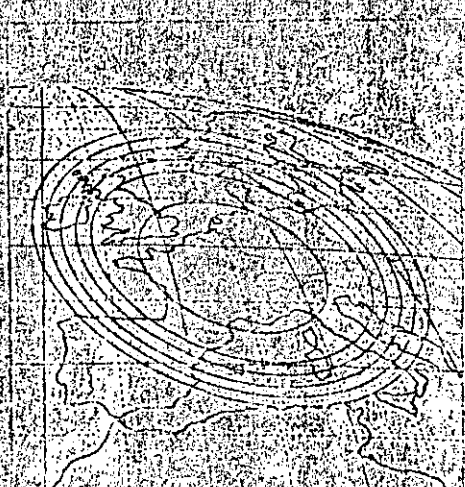


FIGURE 2. NATIONAL COVERAGE

2.6 Earth stations for business services

The following standard type of earth station will be installed at or near the customer's premises. These low cost earth stations will operate unattended. It is therefore highly desirable that the transmitter does not exceed

200 W category in order to keep the capital and operating costs at a low level for critical unit. A low noise FET amplifier is preferred to a parametric amplifier (even uncooled the receiver). Link calculations indicate under these conditions, a 3.5 m antenna is used to transmit 25 Mbit/s. With this configuration and at elevation angles of 30-35°, the G/T of the station is about 26 dB/K. The corresponding antenna gain is 50.7 dB at 12.5 GHz and 49.5 dB at 14 GHz.

The transmitter will be powered by a 160 W uncooled TWT. The antenna will be illuminated by a circular prime focus feed which simplifies the design and should be a favorable factor for the global performance. The pointing of the earth station antenna will be adjustable in elevation (between 30-35°) and in azimuth. The high precision of the spacecraft position (specified to 0.05° of nominal position) will favor minimum requirements for earth station pointing and allow not using tracking system.

The equipment of the earth stations will be automatically monitored and the information relayed to a regional maintenance center. This center will also perform telecontrol of the earth stations.

In addition to the standard type of earth station, the TELECOM 1 system requires a

reference station for network synchronization and control and for satellite capacity allocation. This will be provided by a 6.5 m antenna with a Cassegrain feed, controlled in azimuth and elevation for satellite tracking. The receiver will include an uncooled parametric amplifier and the transmitter will be powered by a 500 W TWT. In addition to the monitoring functions, this station can also accommodate traffic.

2.7 Earth stations for videotransmission

Two kinds of earth stations will be used for the videotransmission service:

- a small number of mobile transmit stations installed on trailers. These stations will have a 3.5 m parabolic diameter antenna and a 160 W TWT providing an EIRP of 72 dBW. These stations can also be used for the business services described in section 2.2.

- receive stations installed in most cases of the roof of halls and theatres for community viewing. Small 1.8 to 2.3 meter antennas will provide adequate signal quality and should not cause excessive structural loads on existing building roofs since most of the RF equipment will be installed in the building. The receiver will be a FET LNA with a noise figure of 4 dB.

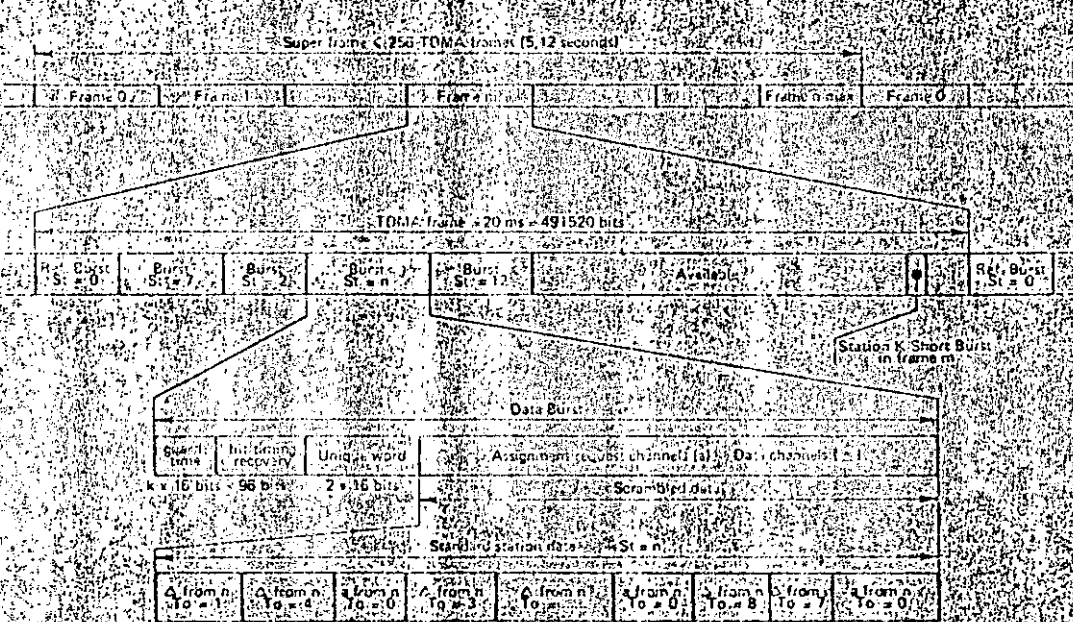


Fig 3- TDMA FRAME STRUCTURE

2.8 Time division multiple access (TDMA)

In order to accommodate the kind of traffic described in section 2.7.2 (bit rate in the range of 2.4 kbit/s to 2 Mbit/s, non-permanent links, variable network structure), a time division multiple access system with demand assignment has been chosen.

The optimum configuration is obtained with most of the control functions centralized in a reference station.

Acquisition and synchronization of the stations, by computation and monitoring of the terminal delays, to be applied by the TDMA terminals with respect to the reception of a reference burst.

Frame management by a centralized assignment of the frame time slots. For that purpose frame management messages are sent to the stations in the reference bursts.

Demand assignment of the communications, centralized set up of the calls originated by the subscribers, using a common channel signalling system, based on CCITT number 7 system.

The type of modulation to be used will be a 2-phase PSK with differential demodulation.

The TDMA frame structure is given in fig. 3.

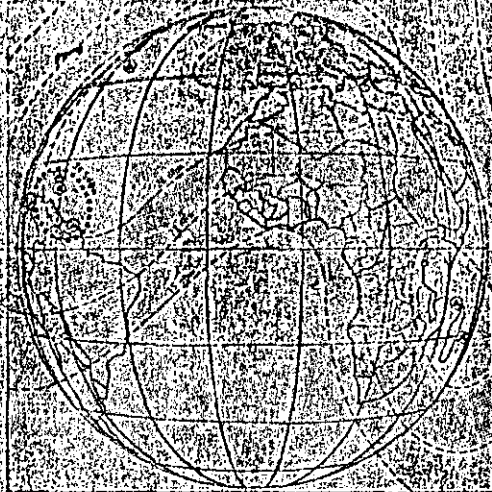
3 - DOMESTIC SERVICES

The telephone and television domestic traffic between mainland and the overseas French departments has been transmitted via INTELSAT and/or SYMPHONIE satellites. On the other hand, the projected requirements for 1989 have been estimated to be 2 800 telephone circuits, one or two television channels between France and the overseas French departments.

These projected requirements for domestic traffic justify the addition of four dedicated 6/4 GHz transponders to the TELECOM 1 satellite. The 6/4 GHz bands were selected for these services because of the existing earth stations using these bands and because of the climatic conditions in the areas of the overseas departments.

Two 40 MHz bandwidth transponders will be used for telephony or television transmissions. They will operate with a global receive antenna and a semi-global transmit antenna. The other two transponders will have a 120 MHz bandwidth and transmit telephone signals. One transponder will operate with a spot-beam transmit antenna covering the French caribbean islands and French Guyana, the second transponder will operate with the semi-global transmit antenna (fig. 5).

The coverage zones at 4 GHz are presented on figure 6.



The plans for this domestic service include an earth station equivalent to the Intelsat standard A earth stations in mainland (i.e. G/T = 40.7 dB/K) and earth stations equivalent to the Intelsat standard B earth stations (G/T = 33.7 dB/K) in each overseas department.

4 - ORBITAL POSITIONS OF THE SATELLITES

The simultaneous coverage of French mainland, the French caribbean departments (French Guyana, Martinique, Guadeloupe), Saint Pierre et Miquelon and the Indian Ocean islands (La Reunion, Mayotte) can be achieved by a satellite positioned between 0° and 10° West longitude. However, other neighbouring satellite networks (current and planned) such as INTELSAT, STATIONAR and ECS further restrict the orbital arc available to the operational and spare satellites of the TELECOM 1 network which will be located at 7° and 4° West longitude.

5 - CONCLUSIONS

The TELECOM 1 network will be very valuable to the business community by providing a wide range of new services according to the needs. The available technology will permit the development of an integrated digital network for voice, data, image and text which is characterized by a high degree of flexibility. In addition, the video-transmission capability will favor the development of this new communication medium and transmission capabilities for telephone and television between mainland and overseas departments will be considerably increased and upgraded.

451

UNISAT UK DIRECT TV BROADCASTING 451

SATELLITE

POR A.G. REED

BRITISH TELECOM

AGENCY

BRITISH TELECOM INTERNATIONAL

URISAT satellites, each carrying 2 fully redundant direct broadcasting TV transponders plus 6 non-redundant telecommunications transponders, are under development for launch either Shuttle or Ariane IV during 1986, with a ground spare. The satellites will be axis stabilised when in station at 329° in geostationary orbit, and are being designed for at least a 7½ year life. TV Broadcasting coverage of the UK to WARC 77 standards will be provided, with the telecommunications transponders will cover most of Europe and 50% of the eastern part of the USA and Canada. The satellites will be administered by United Satellites Limited, a new UK company formed by British Aerospace, Marconi Space and Communications Systems and British Telecom International.

PROJECT ORGANISATION

The first British commercial geostationary satellite will be owned and operated by UNITED SATELLITES LTD, a joint venture company formed by British Aerospace, Marconi (BSM) and British Telecom (BT). The satellite will provide direct television broadcast facilities to the UK and also facilities for business systems telecommunications between small dishes at users premises and the ground. At present two satellites in orbit are envisaged plus a third on the ground as a back up in the event of a failure at launch or in orbit of one of the other two. The BBC will be the customer for the TV transponders, while BT will lease the telecommunications transponders. Prime contractor for design and construction of the satellites will be Bae, who will sub-contract the payloads to MSDS and the ground stations to SATCOM INTERNATIONAL, a consortium in which the principal firms are Bae and MATRA (France).

POLICY CONSIDERATIONS

The UK Government has decided to license the BBC to operate 2 additional TV channels, via geostationary direct broadcasting which will have the advantage of providing nationwide coverage. In addition, this could be achieved via cable networks at the same time, in the wake of developments in the USA. In America, interest is growing in the UK in a mass systems network overlaying the existing private network, to facilitate the establishment of private networks, communications with offshore platforms, ad hoc provision of TV distribution channels, etc. United Satellites therefore made technical and economic trade-off studies of a variety of options for providing these two channels, ranging from a combined D-11a class spacecraft (which would handle only 2 high-power plus 4 telecom transponders) to an Atlas

Centaur class large satellite. The option chosen was a mid-range satellite facilitating 2 TV55 plus 6 telecommunications channels, launchable by STS/PAV-D 11 or as a half share in an Ariane IV launch. (URISAT is being designed with dual launcher capability, and launch slot deposits have been paid to both NASA and ARIANESPACE). The two orbiting satellites, one standby for the other, will be co-located at 329° in the geostationary orbit - the location allocated to the UK for direct broadcasting satellites, and will be designed to maintain station with 0.05° N-S and E-W in order that both are simultaneously visible by small dishes on the ground. Each satellite will be designed for a 7½ year life, but the fuel tank will have 10 year capacity.

PROGRAM

System definition commenced in the Spring of 1983 and was largely completed by end 1983. The preliminary design phase will be completed by mid-1984, and the Engineering Model and final design phase by late 1984. Structural and thermal modelling is expected to be complete by mid-1985, and the first flight model - the "Protoflight" - should be ready for launch in the Spring of 1986. The second Flight Model is scheduled for an Autumn 1986 launch and the ground spare for completion by early 1987. TV service is planned for commencement in the Autumn of 1986 and telecommunications service before the end of that year.

BROADCASTING PAYLOAD

The TVBS payload of each satellite will enable 2 channels to be operated at any time except during eclipse. Each payload will include 16 full redundancy of all active units, and an 8 from 4 redundancy of the 240 watt IRTA output stages. The input and output multiplexers will enable any pair of channel frequencies to be selected from 4 of the 5 bands allocated to the UK by the ITU at the WARC 77 (i.e. from channels 4, 8, 12 and 16). Each channel will provide a beam centre circular to the 65 dBm maximum allowed by WARC 77, the satellite G/T will be better than 12 dB/K and good transmission characteristics have been specified. Each transponder will incorporate a.l.c. facilities to compensate for up-path fades. These characteristics will enable top quality TV signals to be received by ground installations comprising 0.9m dishes and inexpensive front-end receivers. The feed station must be capable of an eirp of the order of 60 dBW, which in the up-path frequency range chosen (17.3 - 19.1 GHz) requires an effective diameter of about 5m. Down-path frequencies are in the range 11.7 - 12.5 GHz and circular polarisation is specified for both links. Virtually the whole of the UK will be covered

by the -3 dB contour, and an automatic pointing mechanism will ensure pointing accuracy within 0.1 degree of the boresite determined at WARC '77.

BUSINESS SYSTEMS PAYLOAD

The telecommunications payload will consist of 6 non-redundant channels (redundancy being provided by the co-located satellite), each having 36 MHz bandwidth, and capable of up to 45 dBW ERP and 3.5 dB/K G/T at the -3 dB beam edge. Two receive/transmit beams will be provided; the east beam encompassing most of Europe within its -6 dB contour while the -6 dB contour of the west beam covers most of the eastern parts of the USA and Canada. Satellite attitude control will maintain aerial pointing within 0.2 degree. The east beam will operate between 14 and 14.25 GHz on the up-path, and between 12.5 and 12.75 GHz on the down-path. The west up frequencies will be in the range 14.25 to 14.5 GHz and the down frequencies in the range 11.75 to 12 GHz. Linear polarisations will be employed. Each satellite will include switching to enable all 6 transponders to be individually connectable in an E-E or W-E mode, and for 3 to be additionally connectable in an E-W or W-W mode. The up-link frequency bands may be interchanged and each downlink may be switched to the orthogonal polarisation if required, thereby facilitating frequency re-use via an additional satellite. All switching will be telecommandable.

Together with adequately specified transmission characteristics these parameters will enable each transponder to handle 25 Mb/sec bpsk TDMA signals, or about 250 voice channels, between ground dishes of 3.7m diameter within the -3 dB coverage contours, or 5.3m diameter within the -6 dB contours; uncooled receivers and 300W transmitters are assumed for the ground stations. Ad hoc TV communication to cable-head distribution receiving installations is also envisaged.

PLATFORM SUBSYSTEMS

The spacecraft platform will be based primarily on techniques evolved in the OIS, SECS, MARECS and SKYNET satellite programs, the main exception being the propulsion subsystem, where a liquid-fuelled apogee engine will be supplied from the same bipropellant fuel and oxidiser system used by the attitude and orbit correction thrusters. When on station the satellite will be 3 axis stabilised and power will be derived from deployed solar arrays. Conventional earth and sun sensors will be used to detect attitude errors, and fixed momentum wheels to provide attitude stability, with solar sailing assisted by a magneto torquer to provide error correction torques in normal mode. Thrusters will be used only occasionally for orbit drift correction and momentum dumping. The solar arrays will use similar cells to those employed on SKYNET, but overall power requirements will necessitate the use of recently developed panels 25 in each of the 2 arrays, giving an improved power/mass ratio compared with that of the SKYNET arrays. The main body of the spacecraft will be approximately cubic in shape, with the large TVBS main reflector mounted on the earth-pointing face and illuminated by a deployed, offset class 3 main sub-reflector. The two telecommunications

reflectors will consist of offset front-fed reflectors deployed from the east and west faces of the spacecraft body, while the solar arrays will be folded, concertina-fashion against the north and south faces during launch, partially deployed during transfer orbit when the payload will be slowly spinning, and fully deployed once on station.

The structure will consist of a central thrust cone supporting the launch vehicle attachment ring, the apogee engine, and the propellant tanks and complemented by an upper floor and side and shear walls in both n/s and e/w planes. The central cone and the propellant tank supports will be fabricated in CFRP, while most of the rest of the structure will be of aluminium. The platform electronics and payload units will be fixed inside the thermally insulated end walls, with IRTs mounted so that their collectors radiate their heat directly to space. Thermal control will be basically passive, with the exception of electrical heaters for control of certain equipments, e.g. the fuel tanks. The overall temperature level will be controlled by radiator areas in the north and south spacecraft walls, the remainder of the surfaces being insulated by multilayer thermal blankets. Internally, units will have high emissivity surface finishes to reduce temperature differences. TWTs and their power conditioners, and the spacecraft batteries (Nickel Cadmium type, powering 4 telecommunications channels plus platform subsystems during eclipse) will be mounted on the external radiator areas, which will contain integral heatpipes, where necessary, to spread heat energy. Pre-heating of the TVBS TWTs prior to eclipse is proposed, with maintenance of heater current during eclipse. The TTC subsystem will include RF receivers and transmitters operating in Ku band only. Two TTC beacons will provide omni coverage during transfer orbit, and may be used in emergency thereafter, but during normal service on station the command and telemetry signals will be routed via the European telecommunications aerial. An additional 'at beacon' will be transmitted by the North American aerial for ground tracking purposes, and an up-path beacon will be transmitted from the UK at about 17.3 GHz to facilitate tracking by the satellite's TV aerial. An 'On-Board Data Handling' (OBDH) microprocessor-based data bus, similar to that designed for L-Sat will be used to route command and telemetry signals throughout the satellite, with the exception that the attitude and orbital control subsystem (AOCS) units will be linked by a dedicated Modular Attitude Control System (MACS, ESA Standard) data bus. The overall mass of the satellite, including full fuel load before apogee injection, will be of the order of 4500 kg, and the maximum power required from the solar arrays will be about 2.3 kW.

454

THE DIRECT BROADCASTING SATELLITE 454

PROJECT TDF 1

POR J. GEORGY

T D F



THE DIRECT BROADCASTING SATELLITE PROJECT (DBS)

JEAN GEORGY

DELEGATION AUX AFFAIRES SPATIALES

TELEDIFFUSION DE FRANCE

21, RUE BARBES

92120 MONTROUGE - FRANCE

ABSTRACT

This paper deals with a detailed technical description of the French broadcasting satellite (DBS) and with considerations on an operational DBS service which would widen the broadcasting capacity and quality of the ground network by far.

INTRODUCTION

Direct broadcasting by satellite will offer to most of European countries the opportunity to increase their broadcasting capacity which was limited up to now by the congestion of the DBS frequency band of the terrestrial network. In France, the three national TV programs need more than 6200 transmitters and radio relays and 55000 km microwave links. Such a large network is operated by 2500 people all over the territory, covering more than 92% of the population. Despite a considerable effort by the broadcasters, more than 200,000 people may not receive television programs due to the environmental conditions of the place they live, especially in the mountains, where difficult propagation of the DBS waves turns the interference situation into a deadlock.

The satellite appears as the only solution to increase the quality and capacity of the broadcasting networks, and brings many advantages that make this solution so attractive:

an immediate coverage of all the population with uniform high quality signals, no more shadow areas and interference problems between so many transmitters; an increase of the population in position to receive the programs by a large possible spill-over in conformity with the regulation (Final Acts of W.A.R.C. 77 Geneva); a similar investment as compared to an equivalent terrestrial network but a far cheaper running cost.

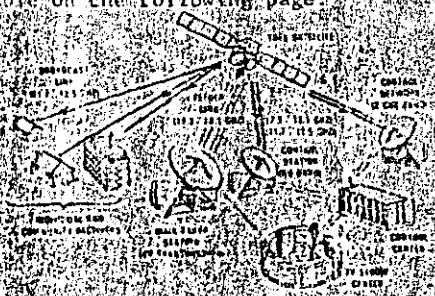
THE DBS FRENCH PROJECT

Due to the specificity of the broadcasting satellite requirements, work in this field has been conducted in France in particular in the sector of high power amplifier in the 12 GHz band and high power/high efficiency solar generators, which are the two main characteristics of a broadcasting satellite as compared to a classical telecommunication satellite. The feasibility studies lead to the conclusion of sufficient trust to start the development of a preoperational system and to go by steps to a fully operational DBS system. In April 1980, France and Germany decided to undertake a cooperative program, the main objectives of which covering the development, manufacturing and launch of two satellites (DBS for France and TVSAT for Germany, besides a spare satellite stored on ground for back up. These satellites will call upon common technical solutions, except for the equipments specific to the different mission requirements (antenna aperture, frequencies...) defined by the national administration (Telediffusion de France and Deutsche Bundespost).

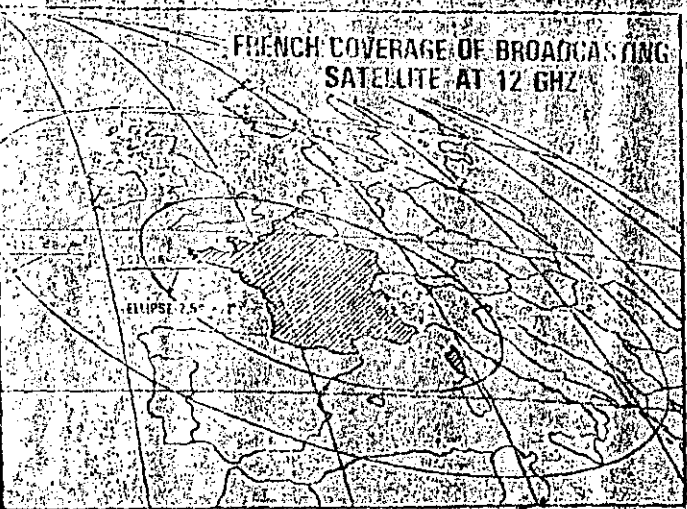
THE SATELLITE (DBS)

The main specifications of DBS are mentioned in the table on the following page.

DBS
BROADCASTING
SATELLITE
SYSTEM



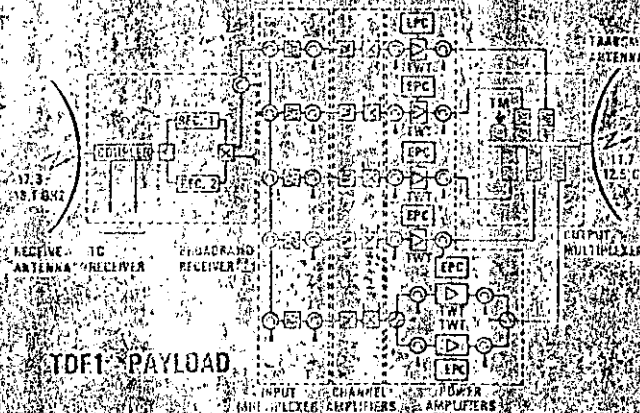
FRENCH COVERAGE OF BROADCASTING SATELLITE AT 12 GHz



BROADCASTING CHANNELS IN THE 11.7-12.5 GHz BAND	1, 5, 9, 13, 17
EIRP IN dBW	103.8, 63.8, 103.8, 64, 64
POLARIZATION	RIGHT HAND CIRCULAR
NOMINAL ORBITAL POSITION	19° WEST
STATION KEEPING	0.1° E/W 0.1° S/N
LIFETIME	7 YEARS
Tx COVERAGE AREA	ELLIPTICAL
HALF-POWER BEAM WIDTH	2.5° x 0.96°
BUREAU COORDINATES	45.9° NORTH
ORIENTATION OF THE ELLIPSE	2.6° EAST
POINTING ACCURACY	±160"
Rx POWER FLUX DENSITY	FROM -52 TO -74 DBW/M ²
FREQUENCY BAND	12.3-12.7 GHz
HALF-POWER BEAMWIDTH	0.7° x 0.7°
FORESEEN RELIABILITY (AFTER 7 YEARS)	0.8
SINGLE POINT FAILURE PROB	< 0.04
TX FREQUENCIES	12.0, 12.3 GHz
TRANSFER PHASE ON STATION PHASE	17.3, 18.1, 11.7, 12.5 GHz
LAUNCHER	ARIANE-2

The broadcasting satellite TDF1 will provide by the end of 1985 three high power television channels for individual reception. The satellite itself has been designed with five independent modules:

- antenna module
- communication module
- service module
- solar array module
- propulsion module

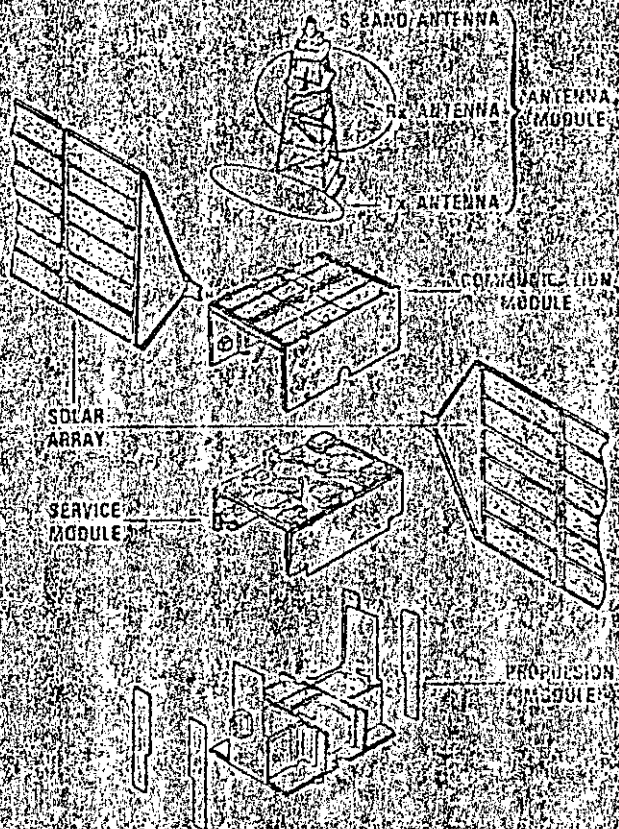


TDF1 PAYLOAD

antenna module: TDF1 uses separate receive and transmit antennae. The two dishes are mounted on a common antenna platform with a tower bearing the RX and TX feeder systems. The TX antenna is based on a elliptical reflector of 2.4 x 1.0 x 0.9 m with a multibeam array (9 hexagonal horns) and a RF sensor (monopulse). In order to

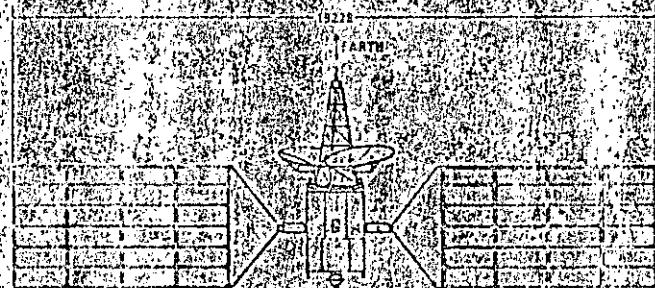
fulfill the WARC-77 pointing accuracy, the TX and RX reflectors are mounted on automatic pointing mechanisms with an average accuracy of 0.05° for TX beam (RX beam is relayed to TX beam).

TDF1 MODULAR CONFIGURATION



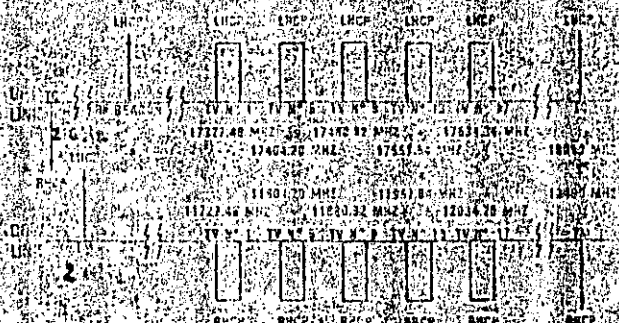
the communication module (the payload on the communication module) is equipped with a redundant broadband receiver, five channel amplifiers, and six transmitter stages (TWTAs - 50 Watts) on five frequencies. The design of the power system is such that only three out of the five channels can be operated simultaneously. This concept provides full redundancy on each of the five channels when two such satellites are in orbit.

THE 1-ORBIT CONFIGURATION



service module. The attitude control system (ACS) consists of gyroscopes, sun sensors, and a star tracker. The ACS is designed for three-axis attitude control. Six-axis motion control is provided for the service module. The power range of the payload (radio transmitters), a system in digital mode, consists of a charge-coupled device (CCD) very good efficiency, low dispersion and high current handling capability. Two separate buses are provided for the main bus to the payload during sun phase and a permanent bus to the payload during all phases including eclipses. A battery capacitance plot is provided during launch, transfer and eclipse. The T and C operations are available on two links. Ku-band through plane antenna during the nominal mission, and S-band through a quasi-omni-directional antenna (R/X) at the top of the antenna tower during transfer and as back up.

TDRS-III ENERGY PLAN



— solar array module: the dimensions of the solar array are 1.6 m by 1.6 m. The solar array module is designed to provide a maximum active surface versus available volume under Ariane II shroud (two wings of four panels each of 1.6 x 1.6 m). The power capability beyond of life (7 years) is more than 3,300 watts at equinox.

— propulsion module: all necessary propulsion manoeuvres will be performed by the Unified Propulsion Subsystem (UPS) with one 400 Newton thruster for apogee boost and fourteen 10 Newton thrusters for all other propulsion needs. Four surface tension tanks store the necessary propellants (MH and N2O4) and two high pressure tanks contain the liquid oxygen pressurization.

The overall thermal control of the spacecraft is designed on the extensive use of heat pipes and compensating thermal loads to be used whenever traveling wave tubes are switched off.

The design of the TDRS-III is fitted to three simultaneous operating channels but is conceived to allow with only minor changes an increased broadcasting capacity up to five fully redundant channels on board each satellite.

Parameter	Value
Operating Frequency (GHz)	17.3-17.7
Power (dBW)	100
Operating Bandwidth (MHz)	40
Operating Bandwidth (MHz)	60
Minimum Link Loss (dB)	103
Free Space Loss (dB)	162
Minimum Power Flux Density (dBW/M ²)	103
Minimum of Intermodulation (dB)	60
C/N ₀ (dB/Hz)	188
Min. C/N ₀ (dB/Hz)	174
S/N video (weighted) minimum	45
S/N video (clear sky condition)	48

Mass budget (in kg)	Value
Repeater	109
Antenna	101
Power	80
Solar Array	167
TDRS-III	41
ACS	48
UPS	110
Structure	175
Thermal	76
Electrical System	55
Balances	5
Total dry	967
Propellant	1008
Adapter	107
Launch	2165
Margin	52 (5.4%)

Power budget (in watts, end of life)	Station	Equipment
Beam	590	590
Thermal	140	280
Battery charging	80	95
Payload	2,125	2,125
TOTAL	2,875	3,090
NB panels	2,060	2,060
SA power	3,060	3,312
MARGIN	6.5%	7.2%

SOME ASPECTS OF THE GROUND SEGMENT

The main feeder link station will use the 17.3-17.7 GHz frequency band with a maximum EIRP in the range of 80 dBW per channel. This power will ensure an excellent C/N ratio at the input of the satellite receiver (more than 24 dB for more than 99.9% time). The control station in Ku-band will generate commands, tags and demodulate the telemetry signals during on station phase. Some specific message related to the payload configuration and management will be available directly at the feeder link station. A specific control network in S-band is devoted to the transfer phase control mission and remains available on request in case of loss of the attitude of the S/C when on station.

Finally a specific beacon will be implemented on ground close to the boresight of the beam for the fine pointing loop of the TX antenna of the satellite.

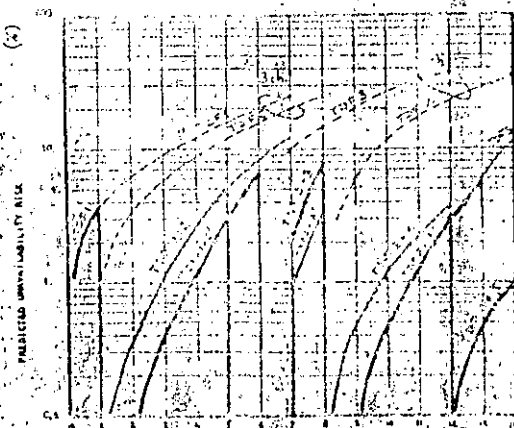
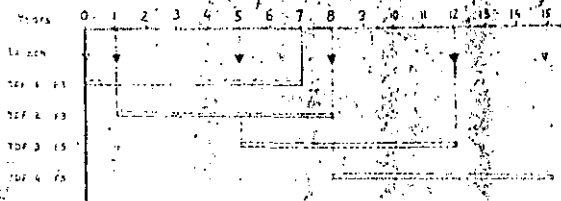
SCHEDULE

The development of this new platform, optimized for high power capacity payloads, requires special studies of the structure, the thermal control and compatibilities between all the modules (EMC). Several are thus developed for different tests and the protoflight model will be delivered in Springs 1985, ready for launch after transportation at Kourou (French Guyane) in Summer 1985.

AN OPERATIONAL BROADCASTING SATELLITE SYSTEM

A fully operational broadcasting system requires two spacecrafts on orbit in order to prevent the system from a total loss of the broadcasting programs in case of a failure of the payload or the platform. A second satellite, identical to TDF1, will offer all the guaranties of availability and continuity of the broadcasting channel. Such a satellite could be scheduled in orbit one year after TDF1. Furthermore, the capacity of such a system could be increased up to four channels if required.

A theoretical approach of the risk of unavailability of the system, based on the foreseen reliability of the equipment and subsystems chosen in the design of TDF1, leads to an optimised renewal of the spacecrafts in orbit. During the two first years in orbit, two S/C may offer sufficient reliability by themselves and additional studies are devoted to the extended five channel capacity spacecraft. Then, this second generation satellite will remain on ground as a back-up and will be launched when additional broadcasting capacity is required. Then, each four years, the launch of a satellite will bring sufficient flexibility to the system and will minimize the risk of unavailability of the total capacity, even in the case of failure during launch operations or before the end of the nominal lifetime of the satellite.



THE BROADCASTING PROGRAM

A wide range of new programs and services may be foreseen for the satellite broadcasting system in France: television programs with high quality digital multivision, teletext, data broadcasting, subscription television and specialized ciphered programs for limited audiences. The cost of the individual reception equipment is foreseen in the range of 500 US \$ including installation on rooftop. The number of such receivers is expected to increase from 200 000 units per year up to 2 M. units/year on a five year period. Cable distribution will also greatly support the reception of these new services in urban environment.

As far as the standard of the DBS signals is concerned, TDF is keen to use the opportunity to maximize the technical capabilities of its satellite system and to offer the largest flexibility to the introduction of data broadcasting, scrambling techniques. Among all the technical possibilities for colour coding and sound transmission (SECAM/PAL/MAC/frequency or time multiplexing) under study within European Broadcasting Union, the choice will be based in a very near future on the best approach to benefit by the large spill-over of the broadcasting satellites.

THE COST OF THE DBS SYSTEM

What are the investments for the overall project? On a basis of a fully operational broadcasting system including two satellites in orbit and a spare on ground as a back-up, the overall investments are evaluated in the range of 300 M. \$ US which may be split as follows:

- 3 satellites (TDF1/TDF2 + spare)	135
- 2 launches by Ariane II	110
- insurances	20
- feeder link stations, microwave links	14
- TTC stations for two satellites	5
- running costs over 7 years	21

This overall cost covers all the facilities to provide four TV programs during seven years, i.e. an average cost of 11 M. US \$ per program per year. This amount remains considerably below the cost of an equivalent ground network.

CONCLUSION

The DBS project TDF1, scheduled to open an operational broadcasting service in 1986 will provide new TV programs and services to the French viewers and to a large neighbourhood. The technology needed to implement such a system is now available for high power satellite design and manufacturing as well as ground individual, low cost receiving equipments. The success of this audacious operation relies in the attraction of the television and sound programs which should incite large people to acquire their own home receiver.

Getting set for direct-broadcast satellites

**Three different technical approaches vie for FCC approval;
here a generic system is examined**

Getting set for direct-broadcast satellites

Three different technical approaches vie for FCC approval; here a generic system is examined

Direct broadcasting of television signals from a satellite to home TV receivers was envisioned some 35 years ago when Arthur C. Clark, a pioneer in satellite communications, broached the idea of putting communications satellites into geostationary orbit. The vision of direct-broadcast-satellite (DBS) television is close to reality today, so close that the main question no longer is whether such a satellite can be put into orbit—one or more will be out there by 1985. The critical question today is which DBS technical characteristics will give the best television reception.

The Federal Communications Commission has before it at least three petitions from potential providers of a DBS service. The three use different technical approaches, and as with any new technology, the commission must consider each approach on its technical, economic, and social merits. The technical

merits are the most crucial, because they have a direct influence on the economic and social ones. Hence, before any DBS system is accepted, two broad technical factors must be evaluated: satellite transmission requirements and home-terminal receiver requirements.

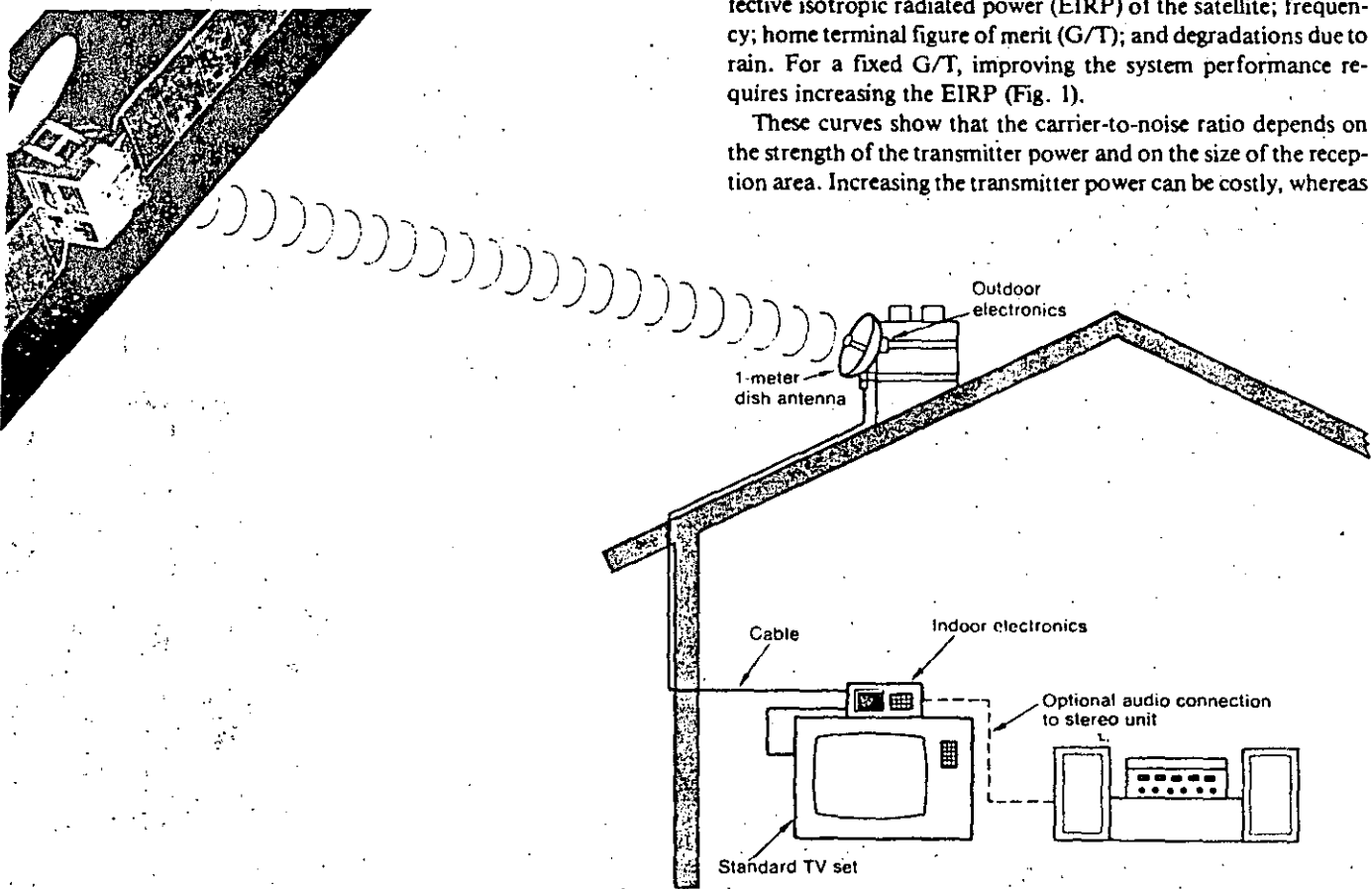
The new television network will be broadcasting programs from 35 786 kilometers in space to a 1-meter antenna at each viewer's premises. The antennas will be connected by an FM receiver to currently available television sets. The FM receiver will remodulate the signal to make it compatible with the conventional AM receiver.

Television networks have wrestled with and for the most part overcome most present obstacles to transmitting quality pictures in all weather conditions. But because broadcasts from deep space will have to operate under much harsher atmospheric conditions, a new system transmission profile must be established.

The performance of any communications link, irrespective of its bandwidth, is determined by the carrier-to-noise ratio. In the case of the broadcast satellite, that ratio is determined by the effective isotropic radiated power (EIRP) of the satellite; frequency; home terminal figure of merit (G/T); and degradations due to rain. For a fixed G/T, improving the system performance requires increasing the EIRP (Fig. 1).

These curves show that the carrier-to-noise ratio depends on the strength of the transmitter power and on the size of the reception area. Increasing the transmitter power can be costly, whereas

Wilbur L. Pritchard and Charles A. Kase
 Satellite Systems Engineering Inc.



limiting the coverage reduces the service and the income from it. An optimum consumer TV picture would require a carrier-to-noise ratio of 90 dBHz.

Picture quality is also basically related to the ratio, so a way of improving the picture is to use higher figures of merit for the home terminal. This can be achieved with a larger antenna that has a higher gain or with a more expensive receiver with lower noise-temperature characteristics.

Clearing up misconceptions

One often misinterpreted fact is that the relationship between the carrier-to-noise ratio and home-terminal antenna size is independent of carrier frequency. It is independent because the antenna gain of the home terminal depends on the square of the frequency in exactly the same way as the free space loss. Therefore in the equation for transmission power, the two variables cancel each other.

Another misconception is that using higher carrier frequencies allows the use of smaller antennas. In fact, for a given power level in a satellite and a given coverage area, the move to higher carrier frequencies requires larger antennas to achieve the same quality picture because of atmospheric and rain losses. In the U.S., frequencies in the 12-to-14-gigahertz range will probably be used for broadcast TV because of their adequate bandwidth and because signal interference is minimal. Thus to maintain picture quality with the atmospheric losses, high-power signals for the smaller antennas will have to be used in the satellite.

To conserve transmitter power, an FM method must be used. A basic tradeoff between carrier-to-noise ratio and the available radio frequency bandwidth per channel is crucial to determining the modulation scheme. If a weighted video signal-to-noise ratio is used, the desired picture quality can be plotted against the available RF bandwidth (Fig. 2). For an excellent consumer TV image, the range for signal-to-noise ratio is 45 to 50 decibels. For an acceptable picture it can be as low as 40 dB. If an FM carrier-to-noise ratio of 10 dB can be met, tremendous improvements in picture quality are possible with only small increases in power by going to broader bandwidths. To transmit an optimum consumer TV picture with its required carrier-to-noise ratio of 90 dBHz, and to cover all U.S. time zones, a 200-watt transmitting tube must be used. In turn, the home terminal should have a figure of merit of 12 dB/K. The desired bandwidths for such a scheme, even with a margin for rain, are probably above 20 megahertz. At present, potential operators are considering 27-MHz bandwidths.

Specific slots will be allocated to users at the 1983 Regional Administrative Radio Conference (RARC). Unfortunately, using broader bandwidths will reduce the channels available in space for direct broadcasting. The move toward broader bandwidth is particularly strong in the U.S., where TV picture quality is lower than that of European pictures. Interest in high-resolution television, which has twice the number of lines now in use, is increasing [see "A step toward 'perfect' resolution," *Spectrum*, July 1981, p. 56].

One way of mass-introducing high-definition TV is through direct-broadcast satellites, which can accommodate the larger bandwidth. These satellites will also provide the necessary bandwidth for quality audio transmission to accompany the video. Using the available bandwidth, however, a tradeoff is needed between picture and audio quality.

If satellite TV pictures were broadcast with the low-fidelity sound channels now used for very high-frequency television, the viewer would find the resulting contrast of audio and video quality analogous to watching a live performance of classical music

and hearing the music as if through a telephone receiver. Two wideband high-fidelity audio channels should be supplied for the stereo transmission of music. Separate audio channels are also important for bilingual programs, which could use one channel for each language. With available bandwidth, the video-audio tradeoff assumes a constant bandwidth and carrier-to-noise ratio (Fig. 3).

To accentuate the tradeoff, four subcarriers are assumed. The curves reflect the basic FM improvement equations, which are based on the audio signal frequency-modulating the subcarrier and it in turn frequency-modulating the main carrier. The curves show that a large variety of systems using many modulation and multiplexing schemes can optimize the trade between audio and video quality.

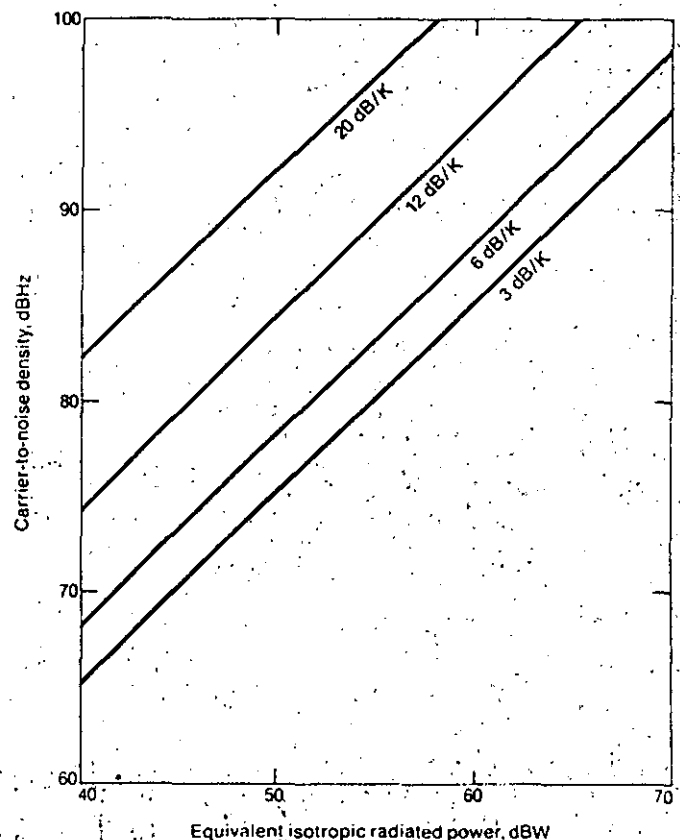
The variable at the home terminal

To deliver a quality picture to the home terminal, two random variables must be addressed: the subjective perception of picture quality and attenuation due to rain. Both ultimately determine how successfully the system performs.

Studies of subjective evaluations of picture quality have been made worldwide, with the results hinging on video signal-to-noise ratio. An average ratio of peak-to-peak signal to weighted noise level of 40 dB is acceptable to a majority of viewers.

Cable systems are typically designed for reception from satel-

[1] Carrier-to-noise ratio is determined by the spacecraft's effective radiated power (EIRP) and the home receiver figure of merit (G/T). For a fixed receiver quality, carrier-to-noise ratio can be improved by increasing EIRP. This may be accomplished by either increasing satellite transmitter power or reducing coverage area (increasing antenna gain). These curves assume an operating frequency of 12 GHz. For a typical receiver noise figure of 3.0 dB, the antenna diameters would range from 0.36 meters for the 3-dB/K case to 2.5 meters for the 20-dB/K case.



lites with picture signal-to-noise ratios of 50 dB, although much lower values are perfectly satisfactory for a home terminal. The smallest terminals and the worst conditions of high rain and low angles of elevation decrease the acceptability level to the 30-dB level. At that point the viewer probably turns the set off in disgust.

Attenuation due to rain is a more difficult problem. Both the

rate and volume of rain vary extensively around the U.S. A rain attenuation model, drawn up by the National Aeronautics and Space Administration for the 12-GHz broadcast band, summarizes the different climates in the U.S. The hardest to deal with is that of the Southeast, particularly in Louisiana and Florida.

945

To illustrate how the climate curves reflect the video signal-to-noise ratio, they are plotted against percentage of time for each climate type (Fig. 4). The picture quality in the worst climate would be usable until the carrier-to-noise ratio dropped below the FM threshold. This would happen about 0.2 percent of the time in the U.S. This amounts to almost 18 hours a year—enough to prove frustrating to viewers, who would inevitably have to acquire larger and more expensive antennas.

A critical characteristic for receiving quality pictures from a direct-broadcast satellite is the figure of merit (G/T) of the home terminal. At a particular frequency, this figure simply depends on the size of the antenna and on the system noise temperature of the receiver. The system noise temperature, for its part, is affected by rain. Rain not only weakens the signal but also increases the antenna temperature. This temperature must be added to the low-noise amplifier temperature to set the system noise temperature. Variation of the antenna temperature is particularly distressing because the system temperature margin that can account for a high G/T is obliterated just when the margin is needed the most. System temperature in clear weather and antenna size are thus not perfectly interchangeable.

For the same ratio, a larger antenna is better than a lower clear-weather system temperature, because the increased gain of a larger antenna is not affected by rain at all.

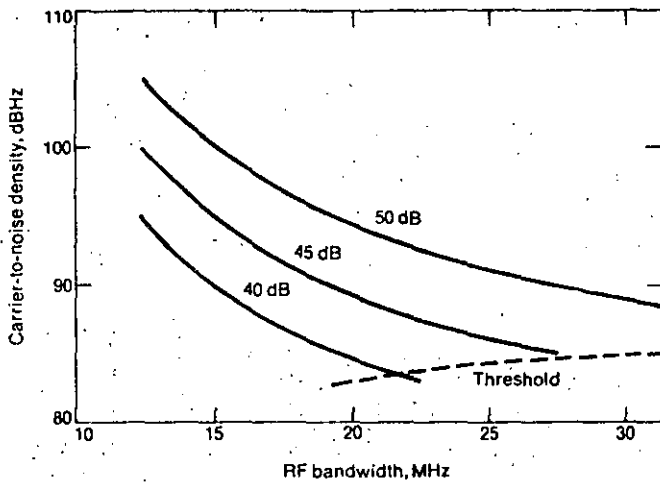
A plot of the figure of merit versus antenna diameter for different low-noise amplifier temperatures in both clear weather and heavy rain yields the results in Figure 5. A 1.8-meter antenna with a 480-K temperature and a 1-meter antenna with a 120-K temperature both give the same clear-weather figure of merit: 17 dB/K. However, in heavy rain the larger antenna G/T deteriorates to only 16 dB, whereas the smaller antenna system drops all the way to 13 dB.

Current direct-broadcast satellite plans for Europe and the U.S. specify relatively modest values of G/T, on the order of 10 dB. Rarely do they specify more than 12 or 13 dB. This is based on preliminary cost estimates for the receivers. These estimates are high and will probably come down when a competitive volume market develops, a trend observed with earlier satellite systems. The few thousand large TV receive-only antennas that today are operating at C-band frequencies cost several thousand dollars, compared with \$50 000 to \$100 000 originally. These antennas need to be large because of the much lower satellite powers at C-band transmissions. Home terminals with 1-meter dishes will probably cost a few hundred dollars in large quantities, about the same as present antennas for color television sets. In areas with bad weather or where reception is at a low angle of elevation, 2-meter and larger dishes can be expected.

Designing the satellite

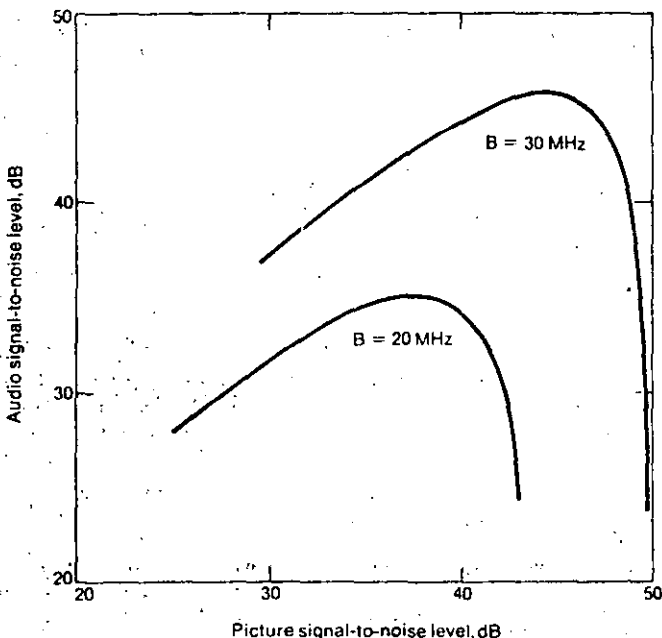
A direct relationship between the total transmitter power required and the mass in orbit of the satellite should be viewed in terms of the total system cost. The power and mass of the satellite, in turn, determine the number of channels that the satellite is able to accommodate. A typical satellite mass can be related to the number of channels available for coverage of an area that is approximately the size of a U.S. time zone, as can be seen in Figure 6.

The sun's eclipse has a direct bearing on the behavior of a mass in space and is used in the figure as a parameter. The order of



[2] When the TV signal-to-noise ratio is used as a parameter, the requirement for carrier-to-noise ratio decreases as bandwidth increases. In FM systems, the bandwidth can be increased and that ratio decreased up to the point where FM threshold is reached. In a practical system, where rain attenuation must be accommodated, a good design would allow several dB margin above the threshold point for clear-weather performance.

[3] When carrier-to-noise ratio and bandwidth are fixed, the performance of either the picture or the audio may be improved at the expense of the other. As the picture quality is improved by increasing its frequency deviation, the audio subcarrier amplitude and deviation must be decreased to remain within the total allowed bandwidth, thus reducing audio signal-to-noise level. These curves assume a fixed relationship between the amplitudes of the video and audio subcarrier, so that only subcarrier deviation is allowed to vary.



magnitude of costs for the satellite and its launch into orbit is about \$100 000 per kilogram. The Thor Delta launch vehicle can put about 600 kg into geostationary orbit and the Atlas Centaur almost double that. The first version of the European Ariane will accommodate about the same load as the Centaur. The Space Shuttle will be able to carry payloads up to 5000 kg into geostationary orbit. However, upper stages must be furnished to take the spacecraft from a parking mode in space into final orbit. Stages of that capacity are not yet available.

The relationships between cost and mass are rather complicated. The weight-estimating model is based on such considerations as transmitter power, efficiency, weight and redundancy, battery charging, structure, attitude control, antennas, and station-keeping propellant. The model compares well with existing and planned satellites. Satellite designers, however, have to take into consideration the satellite's operation under various positions of the sun's eclipse. This consideration is of national importance because eclipse capability will affect how RARC-83 assigns frequency to various countries. When the sun is close to the equator during the spring and autumn, the satellite will enter the shadow of the earth once a day, and it will be necessary to carry batteries to supply whatever power the satellite needs when its solar cells are inactive. The eclipse period is a maximum of about 72 minutes, and the season in which any eclipse takes place lasts twice a year for exactly six weeks before and six weeks after the equinoxes.

The batteries must have electronic circuitry to control their charging and discharging and extra solar cells to charge them during the 22 hours or so between daily eclipses. This added weight of batteries, solar cells, and electronics requires extra structure and station-keeping propellant so the satellite will stay in position at its prescribed longitude and in the plane of the equator. This increases the total mass of the satellite in orbit and the requirements for the perigee and apogee kick engines and the launch vehicle itself. In other words, ensuring operation under differing eclipse conditions means cumulative cost increases.

Fixed-service satellites, with audio and data services from point to point, require operation under full eclipse. Television broadcast satellites that supply entertainment and other services may not require continual operation.

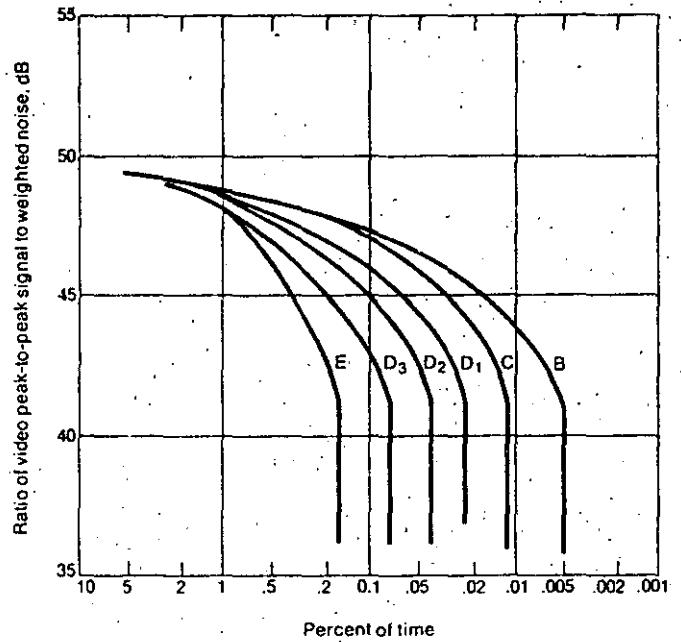
Although some batteries will always be necessary for house-keeping during the eclipse, the greatest fraction of the battery power is required to operate the transmitter. The transmitting power requirement depends on the local clock time at the onset of an eclipse. If eclipse transmitting power could be reduced or eliminated, the saving in spacecraft costs could run into the tens of millions of dollars.

The peak of an eclipse occurs at apparent solar midnight, but the time on a viewer's clock can be considerably earlier. At the longest eclipse, the onset is some 36 minutes before the peak. There is a further difference of about eight minutes at the equinox between apparent solar time and mean clock time. This still presupposes that the viewer is immediately below the satellite on the central meridian of his time zone. Since the viewer can be considerably to the east or west of the subsatellite point, a discrepancy of several hours is possible between the apparent solar time of the peak eclipse at the subsatellite point and the time on the viewer's clock. The local time of the onset of the longest eclipse at the equinox can be calculated as a function of the relative longitude between the viewer and the satellite.

For example, an eclipse might start at 10:30 or 11:00 p.m., when the requirements for television service are extremely high. Since this is still prime time, the satellite could be moved, say, 25° to the west of the covered area, so that to the viewer the onset of

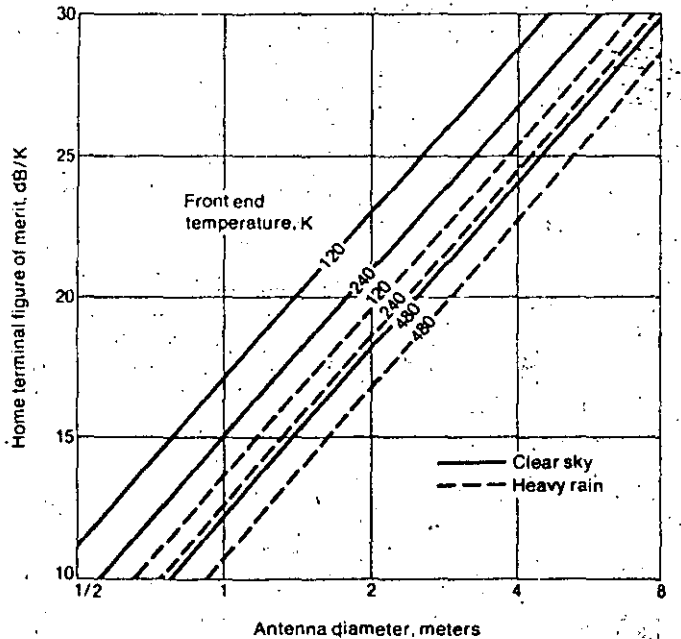
the eclipse would be delayed until 1 a.m. Little or no television service would have to be transmitted during the eclipse. The effects of reducing eclipse capabilities on satellite mass and costs are shown in Figure 7.

There is a drawback to this maneuver, however. Although the



[4] In the 12-GHz band, video performance will degrade during rain. This example shows performance for a system designed to have a signal-to-noise ratio of 50 dB during clear weather. Climate types range from cold and dry areas such as Maine (B) to tropical areas such as Florida and Louisiana (E).

[5] Receiving station G/T is a function of antenna diameter, receiver temperature, and antenna temperature. In heavy rain, the antenna temperature increases from a clear weather value of perhaps 50 K to a maximum value of 290 K (ambient).



LNA temperature, K:	120	240	480
Clear sky total temperature, K:	180	300	540
Heavy rain total temperature, K:	410	530	770

eclipse situation becomes more and more favorable as the satellite is moved to the west of the covered area, rain attenuation becomes more acute. The lower angles of elevation to the satellite cause longer rain paths. At very low angles of elevation, the signal is blocked from neighboring buildings, hills, and trees. Thus to cover a particular service area, the satellite should be "parked" in a sector of the geostationary arc that offers the best compromise between the eclipse service and elevation angle.

For a given U.S. time zone, this sector of the orbit is approximately from 25° to 40° west of the time zone. Compromises like this must be made for both fixed and broadcast satellites operating in the Ku band over the U.S. and the rest of the Western Hemisphere.

Nontechnical challenges, too

Besides the technical issues, the DBS service faces regulatory, economic, and political issues before it can begin operating. Regulatory issues are both domestic, under the control of the Federal Communications Commission in the U.S., and international. The international issues are debated and resolved in the International Telecommunications Union, a United Nations body. Because the radio-frequency spectrum and the satellite's geostationary arc are limited resources, an agreement on allocations will be needed among the countries of the Western Hemisphere (Region 2). The probable result of the upcoming RARC meeting will be along the lines of the agreement of 1977 for the rest of the world, Regions 1 and 3. That agreement called for allocation of arc by country regardless of use. The U.S. position,

allocation according to use, was rejected at that time. The arc in Regions 1 and 3 was divided into national orbital locations and the spectrum into channels. Each interested country received predetermined allocations of orbital locations, channels, and even EIRP power. Although this arrangement may be politically laudable, the results are regrettable from a system-design point of view. The decisions set parameters for some unspecified future systems and did not leave enough room for improvements in space and communications technology.

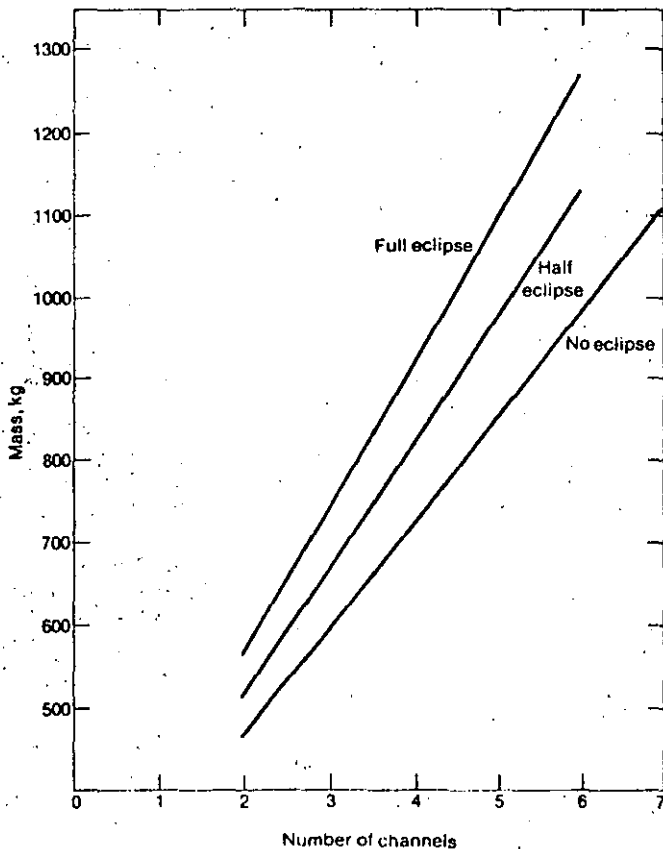
Though this might prove difficult, the upcoming division of resources in Region 2 should take into account probable future technical improvements. The International Telecommunications Union allows each country, regardless of size, an equal vote. Positions in the geostationary orbit can be considered capital assets worth considerable money. By allocating orbital slots by country, the telecommunications union will short-change a large user, such as the U.S., with its large population requirements and vast technological and industrial resources.

On the domestic end, the Federal Communications Commission will allocate the frequencies to competitive applicants. Since frequency-allocation sharing between fixed and broadcast services has still not been determined by RARC, the commission will be hard-pressed to make temporary assignments to DBS applicants. Already operators of fixed-service satellites are complaining that too much of the frequency band is being considered for the DBS service. They fear that this will force the already overcrowded fixed services to higher frequencies, where the problems of rain attenuation become substantially graver than the already serious ones at Ku band.

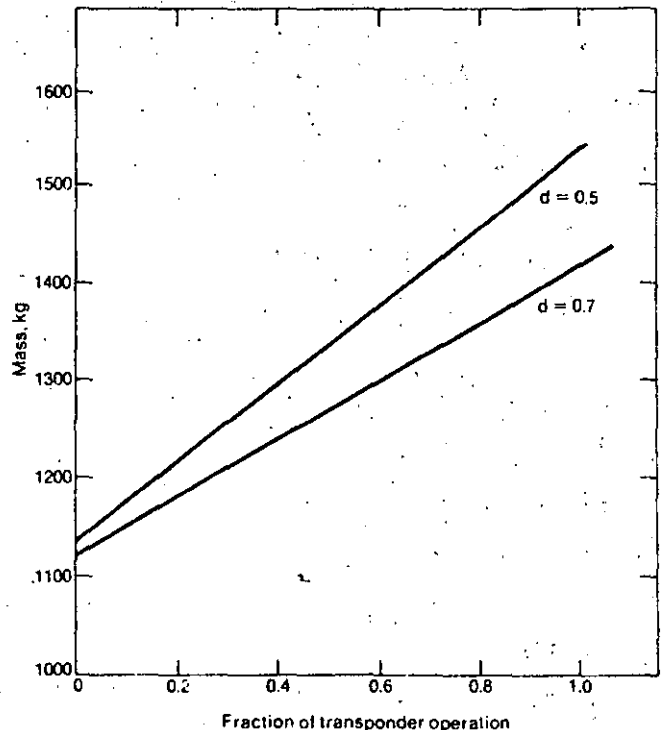
The role of competition

The economic issues for DBS in the U.S. are quite different from those in most countries, where telecommunications ser-

[6] A satellite's mass increases with the number of channels and with eclipse capability. The number of channels determines the solar power requirements and consequently a great part of the mass. Eclipse capability requires heavy batteries and also additional solar power to recharge batteries between eclipses.



[7] As eclipse capability increases, so does the mass required for batteries and primary power to recharge them. A greater depth of discharge (d) reduces battery mass but not primary power requirements.



vices, including broadcasting, are a government monopoly. Also, American free enterprise encourages intense competition. American TV broadcasts are now made by local stations, which certainly view the DBS service as competitive. In addition, fast-growing cable television is serving 25 percent of U.S. television viewers. Cable TV, as well as subscription broadcast television and multipoint distribution service, will also be competition for a DBS system.

Nevertheless, a substantial market exists for the DBS service, which could serve several million Americans who have no televi-

sion of any kind today. These potential viewers live in remote areas that terrestrial broadcasts do not reach and where cable TV is economically prohibitive to install. For less isolated viewers, the ultimate choice between DBS and the others will depend on whether DBS offers different types of TV services. Satellite broadcasters should be ready to make their service attractive to viewers of various tastes. This variety, in turn, will create an incentive for cable operators to increase and extend their interactive, or two-way, services. Such service is relatively simple to install in cable systems and may in the long run prove to be the best

DBS: where it stands before the FCC

At present the Federal Communications Commission has before it only one detailed plan for a commercial direct-broadcast-satellite (DBS) television system. That plan has been submitted by the Satellite Television Corp., a subsidiary of the Comsat Corp. of Washington, D.C. Two other companies—the Direct Broadcast Satellite Corp., a subsidiary of Satellite Systems Engineering of Bethesda, Md., and the Hubbard Broadcasting Co. of St. Paul, Minn.—have indicated they will follow Satellite Television's application with their own, but they have yet to submit technical details. They contend they can offer similar service with better methods.

Satellite Television's plan is tied to the allocation of frequencies by the upcoming Regional Administrative Radio Conference (RARC), scheduled for 1983. That conference, composed of representatives of Western Hemisphere countries, will assign the frequency slots for both broadcast and fixed-service satellites transmitting downlink in the 12- and 14-gigahertz bands.

All three contenders have told the FCC they will transmit quality television images to 1-meter antenna dishes at viewers' homes. The main difference between the three systems is in payment procedures for the service.

Satellite Television's system can be regarded as a cable distribution network in the sky. The viewer would subscribe to and pay for up to three channels of programs. In addition the viewer would pay for the home terminal, including antenna and receiving electronics.

Direct Broadcast Satellite Corp. proposes that it act as a common carrier by using the satellite only to transmit programs. The programs would be generated by other businesses, which would pay Direct Broadcast Satellite fees for the use of satellite transponders. The programmers and terminal manufacturers could either lease or sell the terminals to viewers. Programmer costs would be offset by advertiser and contributor support.

Hubbard Broadcasting wants to act like a space network by providing programs to local television stations, which, in turn, would broadcast the programs to local audiences. The viewer could also receive programs directly from the satellite via an antenna dish. The viewer would not pay for the service at all, since the new network, like current terrestrial networks, would be supported by advertisers.

Last June 1 the FCC accepted an application from Satellite Television Corp. to start a DBS service in 1985. According to the commission's Notice of Proposed Policy Statement and Rule-making, the commission drew up policies and procedures prior to the RARC-83 frequency allocations because the commission was convinced that DBS would "serve the public interest."

The three-year lead time needed to build satellites and the substantial financial investment for both satellite operator and consumer weighed heavily in the commission's decision.

The approval allows Satellite Television Corp. to evaluate the system before the frequencies are authorized by the FCC after the RARC-83 conference. According to company studies, about 1.2 million U.S. households cannot receive any television from terrestrial broadcasting systems and over 4 million households receive only one or two channels. These viewers could be served by DBS. The additional channels may also be used for

programs to specialized audiences. And, finally, DBS may serve as the introductory vehicle for new video devices, such as high-definition television [see "A step toward 'perfect' resolution," *Spectrum*, July 1981, pp. 56-58].

Despite these obvious advantages, there are a number of technical drawbacks to the FCC decision. By assigning the 12-GHz band for DBS downlink operation, the commission will have to accommodate the current users of these frequencies. These include private fixed-service terrestrial communication systems, or over 1400 radio links, and they span communication applications by the industrial, land transportation, aviation, public safety, and local government sectors. The FCC has proposed that, once frequencies are assigned to DBS systems in accordance with the decisions reached at RARC-83, the terrestrial licensees in the 12-GHz bands be required either to adjust their equipment or have their frequencies reassigned to prevent interference with DBS systems.

Numerous studies have been done on the compatibility of services using the 12-GHz and 17-GHz bands, downlink and uplink, respectively. At 12 GHz, the fixed-service transmitters could interfere with the broadcast satellite transmitters, whereas at 17 GHz the fixed-service satellite uplink transmitters used by DBS operators could interfere with fixed-service receivers.

The FCC engineering staff has concluded that, in general, the broadcasting satellite service and the fixed service at 12 GHz cannot coexist in the same geographic area on the same or adjacent frequencies, but that they can coexist operating on widely separated frequencies.

This potential interference problem has users seriously concerned. Microwave equipment manufacturers have lobbied unsuccessfully before the FCC for more tolerance toward terrestrial microwave systems. Harris Communications Division of Melbourne, Fla., and Rockwell International Co. of Anaheim, Calif., for example, have urged the commission to rule on new frequencies by minimizing the cost to private microwave system users.

As it is, the frequency allocation of microwave users has been moved up from original assignments in the 6-GHz bands because of overcrowding there. Consequently users there could not be shifted down to the 6-GHz area, and relocating them to higher than 12-GHz would be costly. Any move above 12 GHz would require changes in antennas and other auxiliary equipment, as well as in the design of transceivers.

Under the proposed FCC rules, the terrestrial user would have to bear all the cost of frequency revisions. The commission feels, though, that given the three-year lead time for construction of a DBS satellite, terrestrial users would feel less of an impact in replacing equipment because of normal depreciation of existing equipment.

Several organizations have challenged the FCC decision on the ground that authorization of a DBS system now would commit the commission to the technical standards of that system. These standards might not be the most appropriate permanent standards, the challengers have argued. Among them are CBS Inc., the National Association of Broadcasters, RCA American Communications Inc., and Hubbard Broadcasting Inc.

—Nicolas Mokhoff

competitive weapon for the cable TV operators. A return link for two-way communications from a small DBS home terminal is, although conceptually possible, only a remote possibility because of interference and capacity problems.

A particularly interesting aspect of the economics of a DBS system is its total cost. As stated earlier, the performance cost of the satellite can be traded off against the expense of home terminals over a wide range. The home terminal costs, when multiplied by millions, yield a total cost for the ground installations that could easily be higher than the cost of the satellites. For a DBS broadcaster willing to pick up the total system costs, an optimum system can be derived (Fig. 8). Depending on the desired picture quality, the system with the minimum cost must provide large satellite power. Most systems under consideration call for satellites with considerably less power.

A choice of economic approaches

There are many possible economic approaches to achieving the optimum cost. One would be to optimize return on investment instead of the total system cost, thereby allowing for the logical alternative—subscriber ownership of the home terminal. Here the incentive would be for the system operator to produce low-cost home terminals in volume and thus increase revenues, rather than promote lower total system costs. Hence the optimum satellite size could vary considerably, depending on whether the operator owned the terminals or the home owners purchased them.

Another way to realize optimum cost is to have a direct-broadcast system operated as a common carrier. Program material could be generated by various sources, including the current television networks, and the satellite operator would transmit the program, without security coding, at no charge to viewers. The latter would supply their own terminals. The costs of the satellite transmission service would be paid by the suppliers of the program material, who could recover the costs either through advertising or from municipally sponsored special programs.

Such a direct-broadcast system would avoid the technically complex and costly equipment needed for secure coding of programs. Subscription services use various coding schemes to deny

access to people who have not paid for the service. This system will also avoid the expensive administrative burden of billings to viewers. But common-carrier satellite service would have to use much larger satellites and many more channels because of the wide variety of program material.

The political issues revolving around DBS are more pronounced outside the U.S. DBS transmissions could spill into neighboring countries, and some countries do not wish to receive broadcasts not subject to political, cultural, or religious censorship. Of the 150 or 160 countries in the world, only a minority have free speech. In the rest of the world, most governments maintain firm control over the dissemination of information to the public. Though technical complexities would make reception of foreign DBS programs difficult, some governments nevertheless insist on very tight specifications on spillover. Their petitions to the International Telecommunications Union call for antenna patterns for a particular country to conform identically to the frontiers of the country. They insist that the radiated power of the satellites outside the frontiers of the specified country be 30 or 40 dB lower than the radiated power of their satellites.

Although antenna patterns can be sharply contoured, this requirement would be extremely expensive to implement. The idea will surely be resisted by those countries that today supply the technology to design satellites and have the traditions of free speech.

For further reading

Direct-broadcast satellite activities before the Federal Communications Commission are cited in the following: Notice of Proposed Policy Statement and Rulemaking #81-181, released June 1, 1981; "Application of Satellite Television Corporation for a Satellite-to-Home Subscription Service," Vol. III, Washington, D.C., Dec. 17, 1980; and "Staff Report on: Policies for Regulation of Direct Broadcast Satellites," Washington, D.C., Sept. 1980.

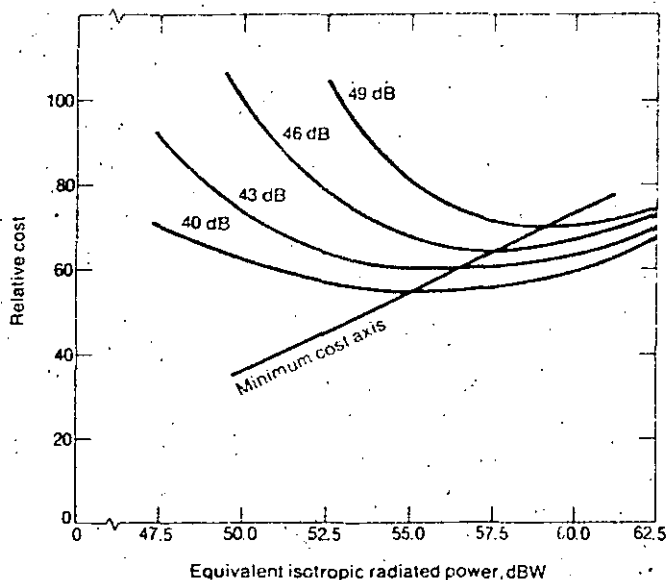
International activity on DBS issues is covered in the International Telecommunication Union's "Recommendations and Reports of the CCIR, 1978," XIVth Plenary Assembly, Vol. XI, Kyoto, Japan, 1978; and Pares, J. and Toscer, V., *Les Systèmes de Télécommunications par Satellites*, Collection de L'Ecole Nationale Supérieure de Techniques Avancées, Mason et Cie, Editeurs, Paris.

About the authors

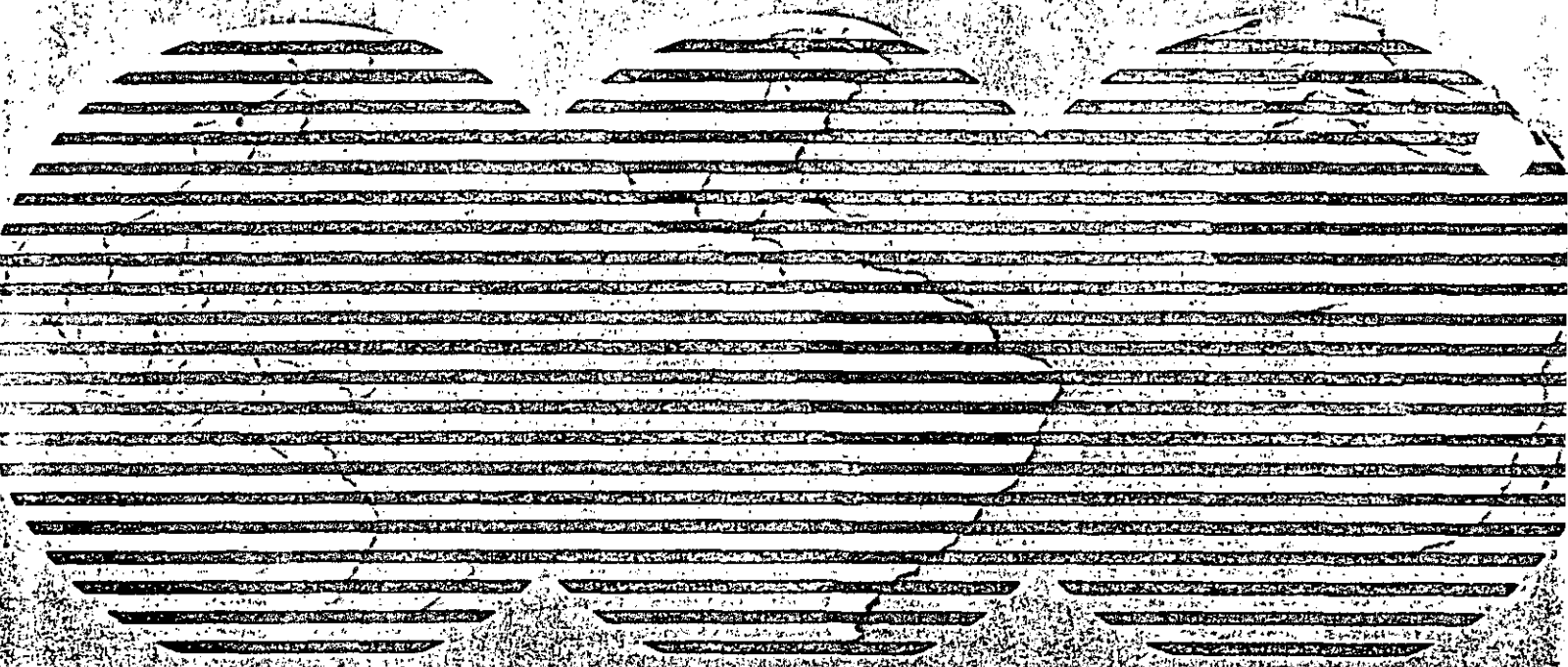
Wilbur L. Pritchard (F) is president of Satellite Systems Engineering Inc., in Washington, D.C., a company he founded in 1974 and which is one three organizations proposing a direct-broadcast satellite system. He has worked in the field of communications satellites since 1962. At Aerospace Corp. from 1962 to 1967, he directed production of the DSCS-1, the first operational military communications satellite. In 1967 he became the first director of Comsat Labs. Mr. Pritchard is a Fellow of the American Institute of Aeronautics and Astronautics. He graduated from City College of New York in 1943 with a bachelors degree in electrical engineering. He did graduate work at the Massachusetts Institute of Technology from 1948 to 1952.

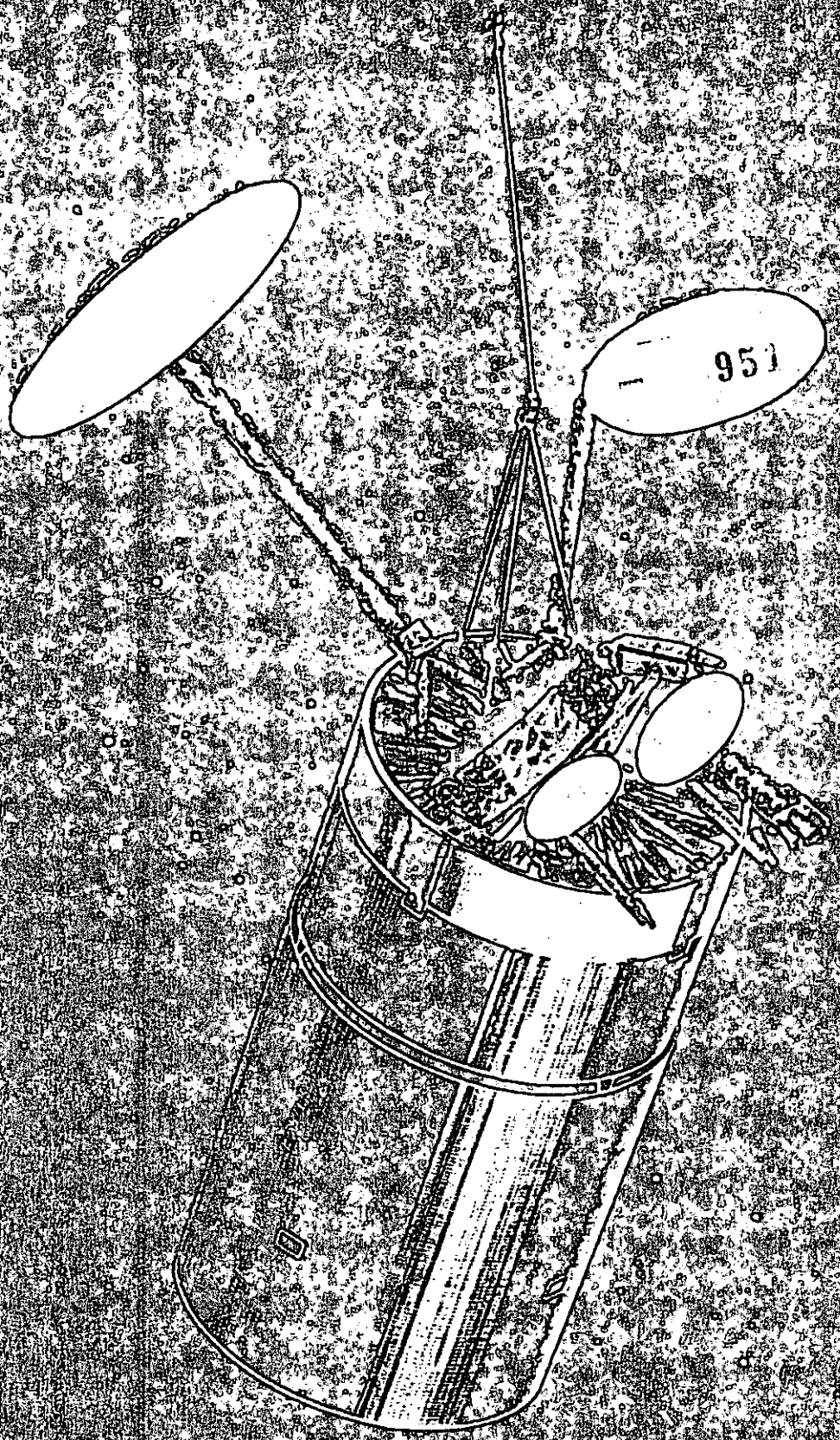
Charles A. Kase is vice president of Satellite Systems Engineering. He has 18 years of experience in the planning, economics, engineering design, evaluation, and testing of large terrestrial and satellite systems. His experience includes planning and design for the Datran digital microwave system, the SBS domestic satellite system, the Intelsat V system, and many other private and government systems. Mr. Kase graduated from MIT in 1962 with a B.S. in mathematics.

[8] Increasing EIRP raises satellite costs and lowers home receiver costs. The sum of satellite and receiver station costs reaches a minimum that varies with system performance requirements.



INTELSAT VI





A PERSPECTIVE

Intelsat VI is the largest commercial communications satellite program ever undertaken. It represents a major challenge, primarily in the area of program management and schedule control. Intelsat is comparable only to satellite programs Hughes has managed for the U.S. Government.

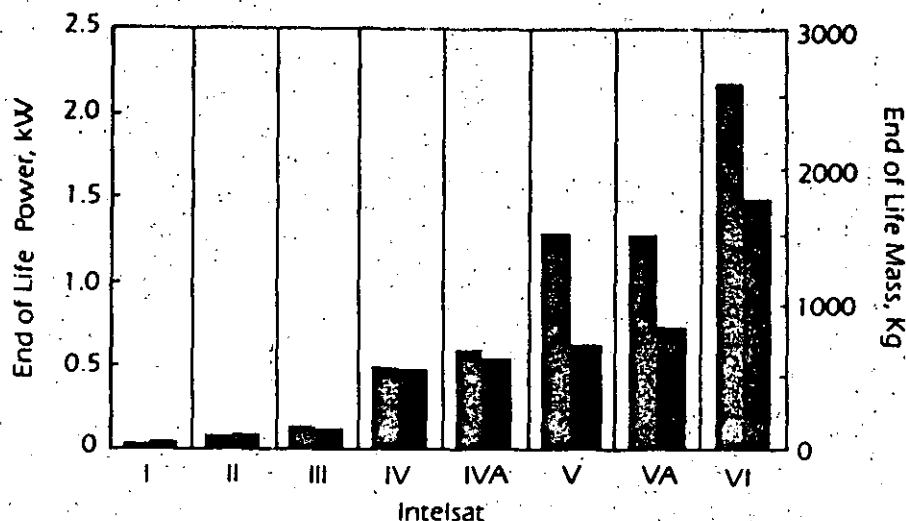
The program was awarded to Hughes as a result of an international competitive tender to which Hughes and Ford responded.

The engineering development and production of the first five spacecraft was contracted by INTELSAT on a firm fixed price basis for \$700 million. The same contract contains options for 11 more spacecraft in the Intelsat VI series.

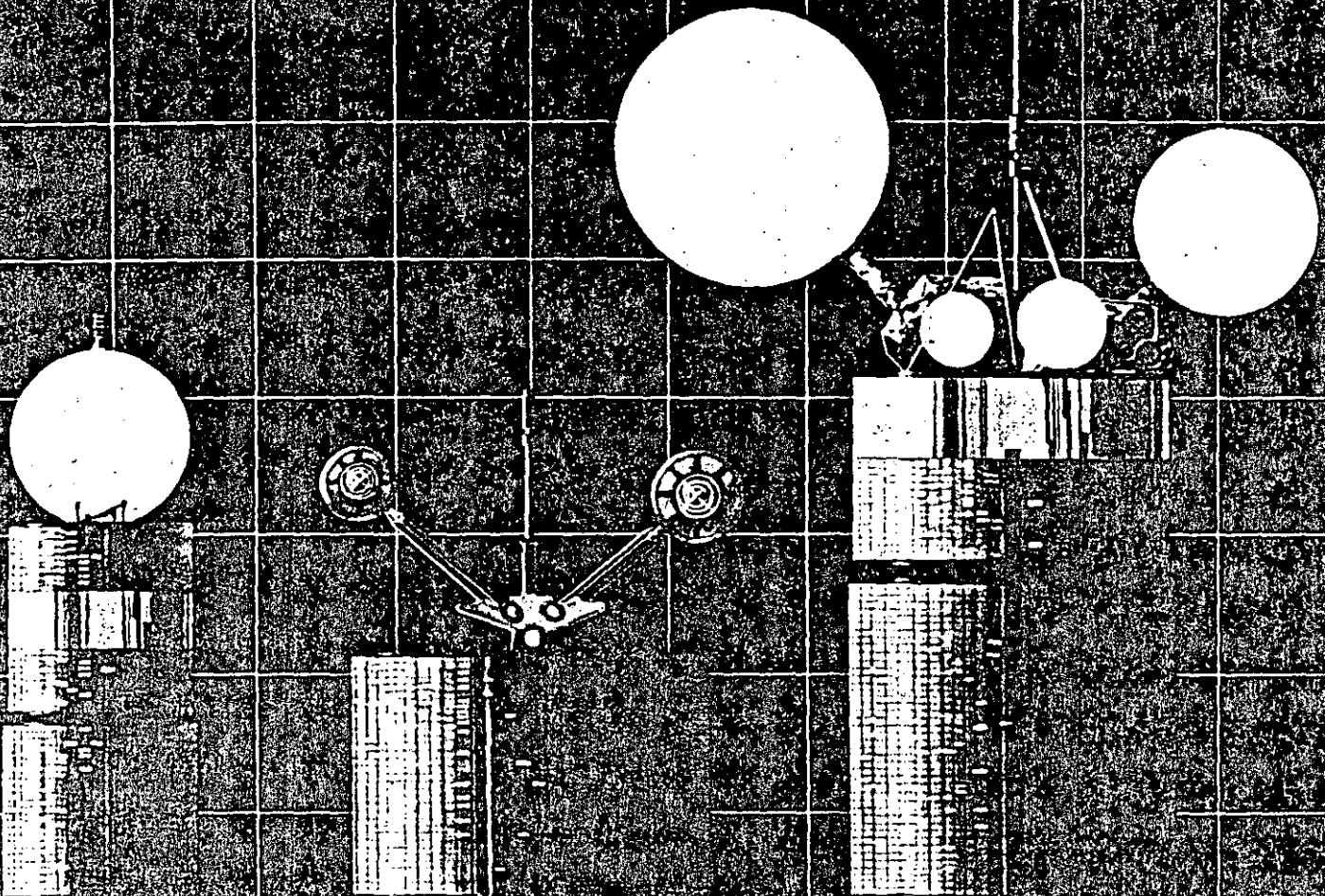
Intelsat VI will have 66,000 half-circuits, three times the communications capacity of Intelsat V. It will generate twice the power of Intelsat V and VA. It will have twice as many transponders and twice the payload mass. It will incorporate satellite switched time division multiple access for the first time.

The first Intelsat VI spacecraft will be delivered in late 1985 for launch in early 1986. It will be positioned over the Atlantic Ocean. Subsequent spacecraft will be delivered in 4-month intervals. Each satellite will provide 10 years of service.

In orbit, Intelsat VI will weigh almost 1800 kg. The satellite will be 3.6 meters in diameter and will stand 11.7 meters when deployed. The solar panels will generate over 2100 watts of prime power.



INTELSAT IN PERSPECTIVE



376 Domestic Satellite

U.S. Government Widebody Spacecraft

Intelsat VI Configuration

DESIGN DERIVATION OF INTEL SAT VI

SYSTEM DESIGN AND CONFIGURATION

The Intelsat VI spacecraft design combines important features of two satellites now in production at Hughes. The first is the HS 376 extended power spinner, which has become a world standard for domestic communications satellite systems. The second is the widebody spacecraft designed for launch on the Space Transportation System (shuttle), which we are building for the U.S. Government. Both designs rely on the dual-spin technology of Intelsat IV and IVA. These satellites were first flown in the early 1970s and continue to perform in orbit today. Of the 33 satellites now in commercial service, 28 were built by Hughes and use this technology.

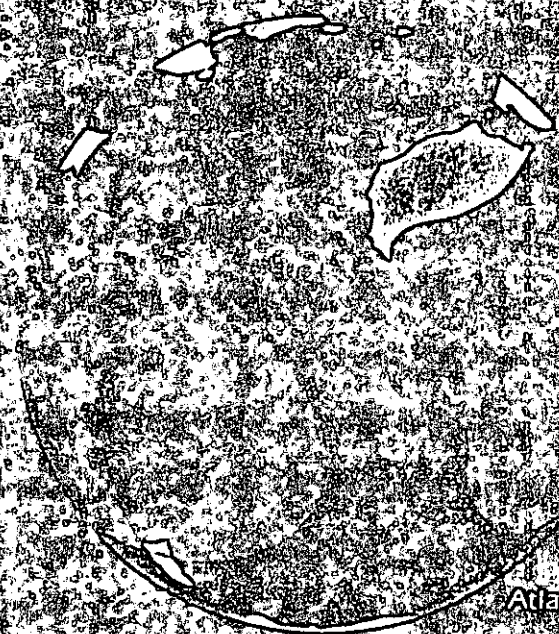
Intelsat VI generates substantially more power than earlier spinners by using two large, concentric cylindrical solar arrays like those used with the HS 376. During launch, its configuration is similar to that of a telescope: the outer array is pulled up over the inner array and main body. Once in orbit, the outer array is deployed downward to expose the inner panel, thereby greatly increasing the available power. Other features of the HS 376 incorporated into Intelsat VI include radial heat rejection, system dynamics and stabilization, structural concepts, and antennas which fold during launch.

Major design features taken from the widebody satellites include the "Frisbee" method of launch from the shuttle. A simple spring and latch mechanism gives an upward motion to the spacecraft, causing it to leave the bay of the shuttle orbiter. This also provides a slow spin for initial gyroscopic stability. Like other widebody satellites, Intelsat VI uses a liquid bipropellant propulsion system and nickel-hydrogen batteries.

This combination of designs is the next logical step in an evolution which has been marked by consistent success.

Dry Mass: kg	
Antennas	291
Repeater	326
Power	336
Structure	282
Bus Subsystems	448
Total	1,683
Margin	98
Ariane 4 Allowed #	1,781
Dimensions: m	
Diameter	3.6
Height	
In Ariane 4	6.4
In Shuttle with PKM #	8.3
On Station	11.7

SPACECRAFT CHARACTERISTICS






Atlantic Ocean Region



Indian Ocean Region



Pacific Ocean Region

-  Hem
-  Zone
-  Spot

INTELSAT VI ANTENNA COVERAGES

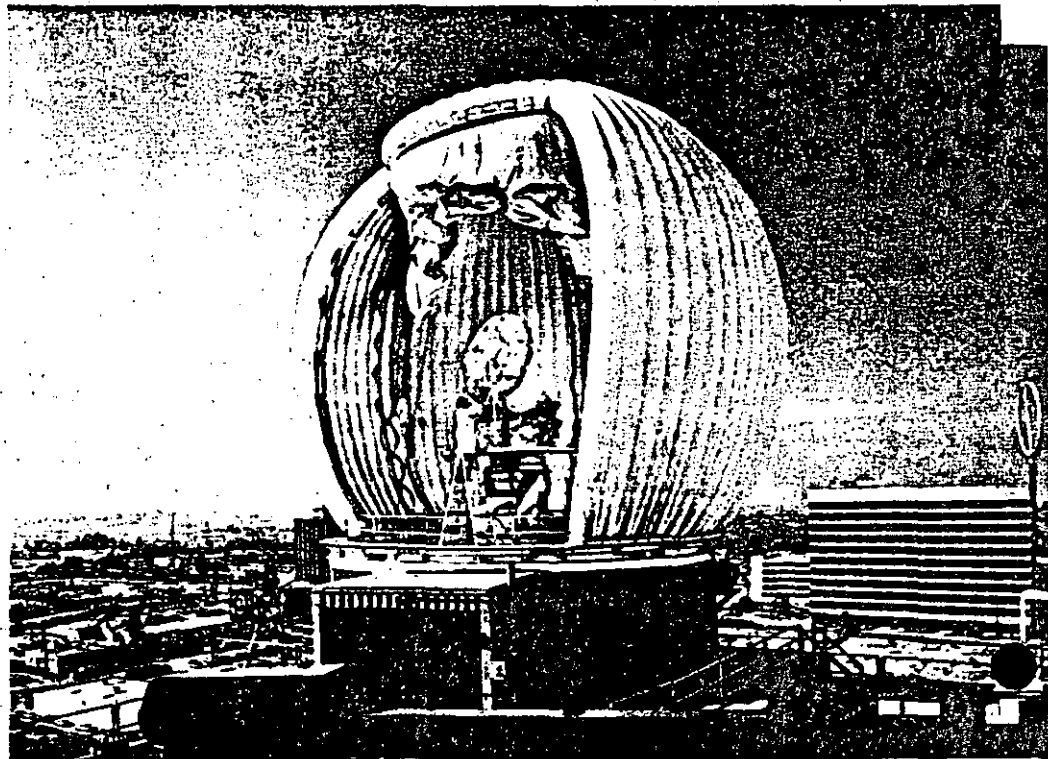
ANTENNAS

The Intelsat VI spacecraft configuration is dominated by the C band hemi/zone antennas and their two large graphite reflectors. The antennas are mounted on the large shelf which also holds the communications repeater equipment. Once in orbit, this shelf and the antennas are despun and pointed toward Earth.

The rest of the satellite spins at 30 rpm throughout the 10-year life to provide gyroscopic stability. The spinning section contains most of the supporting subsystems, including the solar panels and propulsion tanks.

The hemi/zone antenna system was a major design challenge. Each antenna must provide two fixed beams for hemispheric coverage, and four isolated beams for zone coverage. Every satellite must be able to operate in any one of the three Intelsat ocean service regions. Antenna reconfiguration required for the different areas of service is accomplished by a single, redundant mechanism which allows switching of distribution networks in orbit.

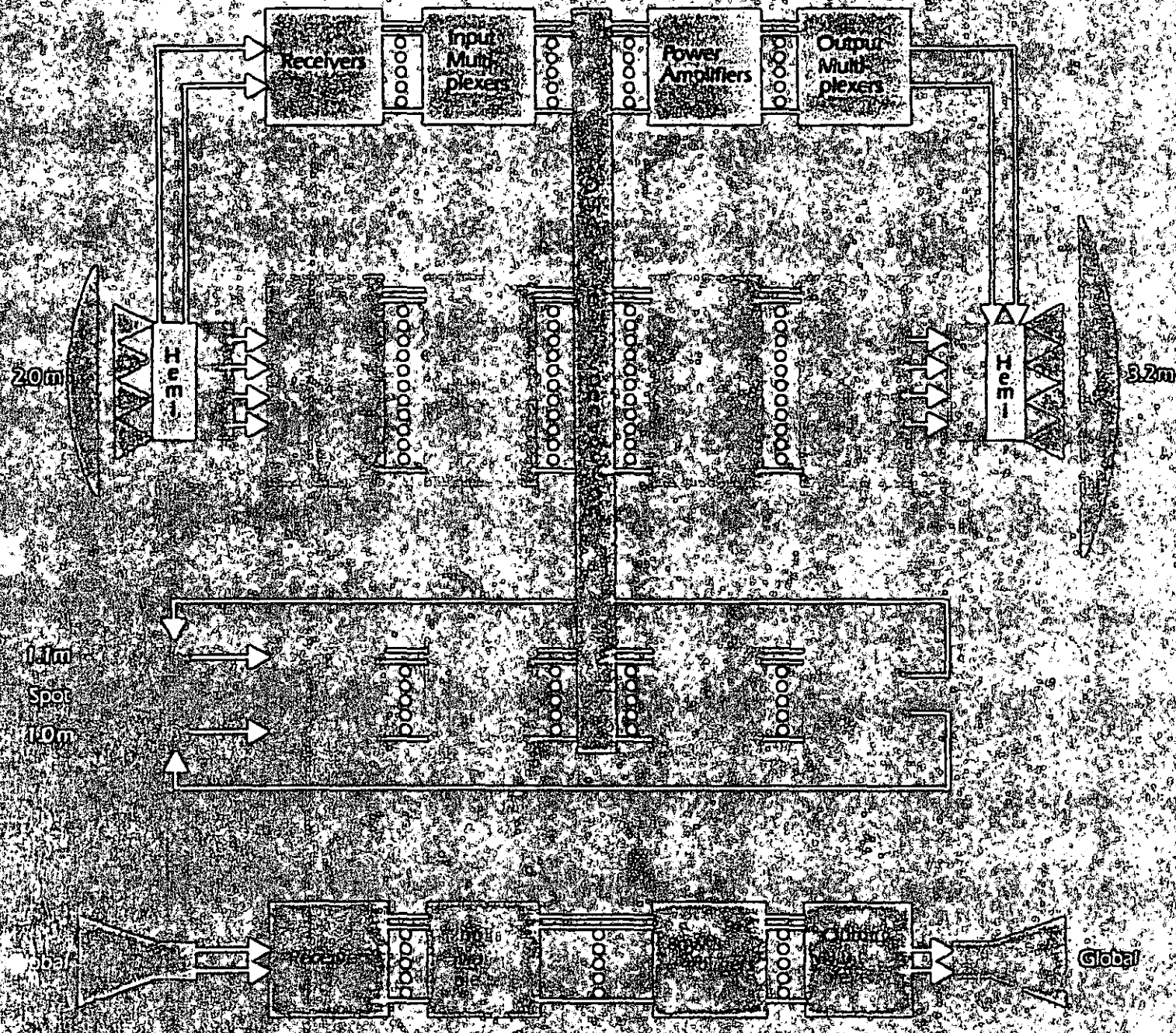
The hemi/zone transmit reflector is a circular aperture 3.2 meters in diameter, and has a 4.2-meter focal length. This large, rigid reflector is stowed for launch and deployed in orbit. The transmit feed array consists of 149 individual feed horns. It has four sets of microwave signal distribution networks, three of which can be switched in orbit. The



Antenna Test Facility

squareax technology produces networks which are predictable and stable.

Intelsat VI also carries two K band spot beam antennas which can be steered in orbit. C band Earth coverage horn antennas and telemetry and command antennas are also included.



COMMUNICATIONS SUBSYSTEM SIMPLIFIED BLOCK DIAGRAM

REPEATER

The Intelsat VI communications subsystem provides 50 distinct transponders operating at C and K band frequencies. The C band payload includes two hemispheric coverage repeaters, four zone beam repeaters, and two global beam repeaters. The K band payload consists of two spot beam repeaters. A block diagram of the entire communications payload and the major repeater sections is shown opposite.

The receiver sections contain a total of 20 receivers, arranged in five groups of four-for-two redundancy. These groups serve the spot, hemi, zone, and global repeaters. All receivers are solid state units based on existing designs. The units use gallium arsenide field effect transistors to achieve noise figures of 3.2 dB at 6 GHz and 5 dB at 14 GHz.

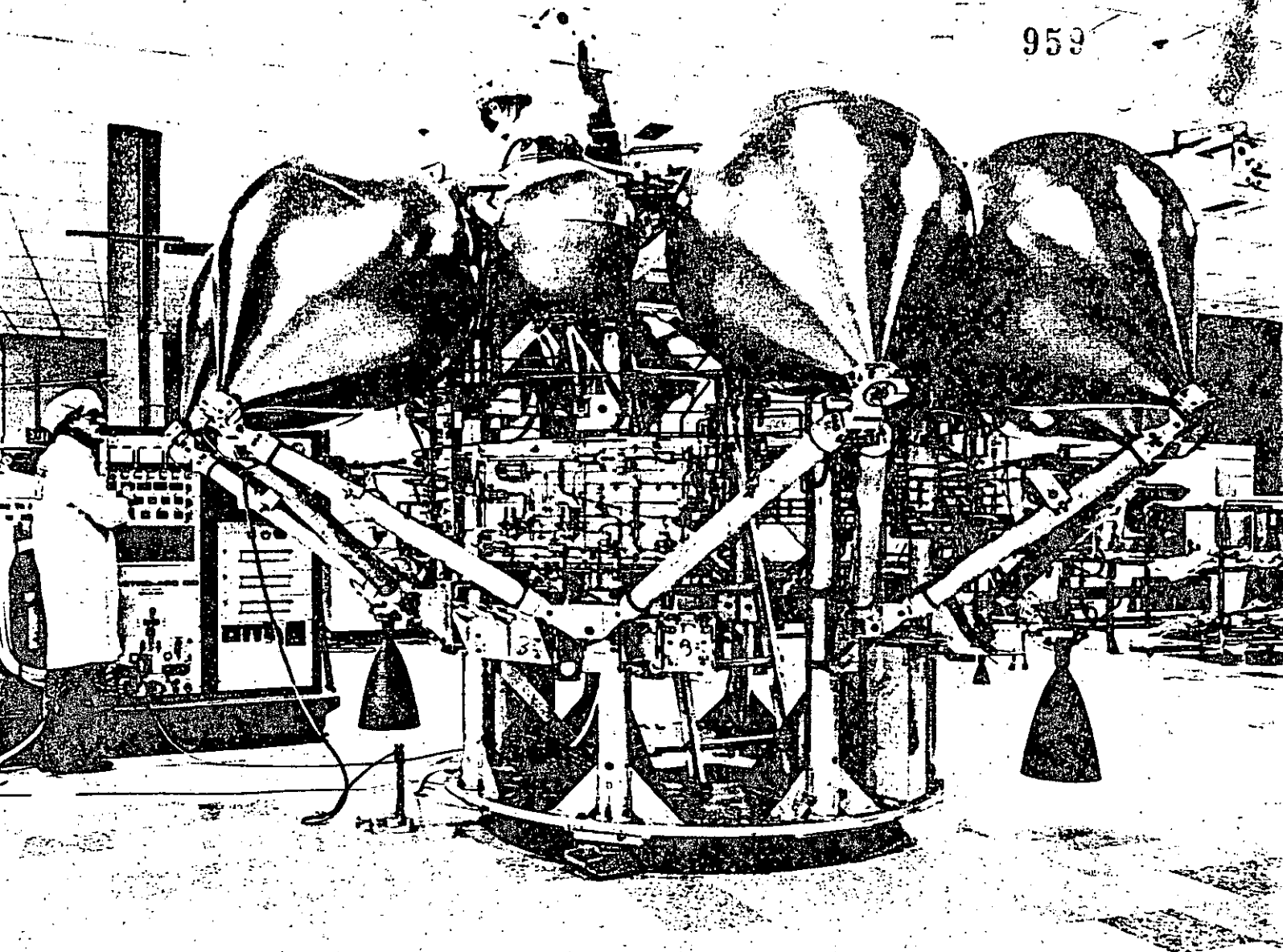
The power amplifier sections contain driver amplifiers, upconverters, traveling wave tube amplifiers (TWTAs), and solid state power amplifiers (SSPAs) in various combinations. In the 4 GHz channels, TWTAs with power levels from 5.5 to 16.0 watts are used for the hemi, large zone, and global repeaters. The small zone repeaters use SSPAs because of their low power requirement. The SSPAs will use gallium arsenide field effect transistors for high reliability.

K band TWTAs, used by Intelsat V, will be modified from 10 to 8.5 watts for the spot repeater at 11 GHz. Power amplifiers are 3-for-2 redundant in all C band

channels and 4-for-2 redundant in the K band channels. The output multiplexers for all repeaters use contiguous channel multiplexing with Invar filters.

Interconnection

The transponders are interconnectable, using either static switch matrices or a new dynamic switching network which provides satellite switched time division multiple access (SS/TDMA) capability. Static interconnection matrices are provided for all channels except those in the global repeaters. Channels 1-2 and 3-4 are connected by dynamic switches to provide SS/TDMA operation. Each of these switching units consists of a dynamic microwave switch matrix, with its associated digital control logic, and an input ring redundancy network with a bypass switch matrix. The dynamic switch is operated by redundant distribution and control units, each with three memories and a very stable timing source. This switch for Intelsat VI represents an important new technology.



PROPULSION

A liquid bipropellant subsystem (LBS) will be used in Intelsat VI. It will perform both apogee boost and stationkeeping functions. The LBS provides high performance through the use of two hypergolic propellants: nitrogen tetroxide and monomethyl hydrazine. The tankage has been oversized to provide spacecraft growth capability for the future.

Four radial thrusters, each with 22 newtons of thrust, are used for east-west

Widebody Propulsion Subsystem

stationkeeping and spinup/spindown control. Two similar axial thrusters provide north-south stationkeeping and attitude control. Two 490 newton apogee thrusters perform the apogee boost and reorientation maneuvers.

The propulsion subsystem incorporates extensive redundancy to ensure mission success. The propellant tanks and thrusters are divided into two functionally independent half systems. They are connected on the liquid side by latch valves and on the pressurant side by squib valves which are normally open.

POWER

The power subsystem is based on existing designs modified for Intelsat VI requirements. Solar panel performance offers a 12 percent margin over the 1919 watt equinox load. It provides substantial performance margins and significant potential for power growth.

The nickel-hydrogen batteries support the full load at 69 percent depth of discharge, even with one failed cell. The predicted load also includes an uncertainty margin for those loads, resulting in an additional margin of 2.5 percent for the solar panel and batteries.

Two independent, preregulated power buses are used, and the power loads are divided equally between them. Tap limiters restrict the bus voltage to 30 volts during sunlight. The battery automatically supplies current to the bus through the discharge controller during eclipse. After eclipse, battery charge current is passively controlled by switching solar cell strings from the main array directly to the battery.

The Intelsat VI batteries are larger versions of nickel-hydrogen batteries which have been developed and qualified at Hughes. This type of battery has demonstrated 6000 discharge cycles, representing approximately 70 years in geosynchronous orbit. For Intelsat VI, we will mount the batteries on a platform at the aft end of the spacecraft, where they can reject their heat directly into cold space. This arrangement provides maximum thermal control and considerable battery growth.

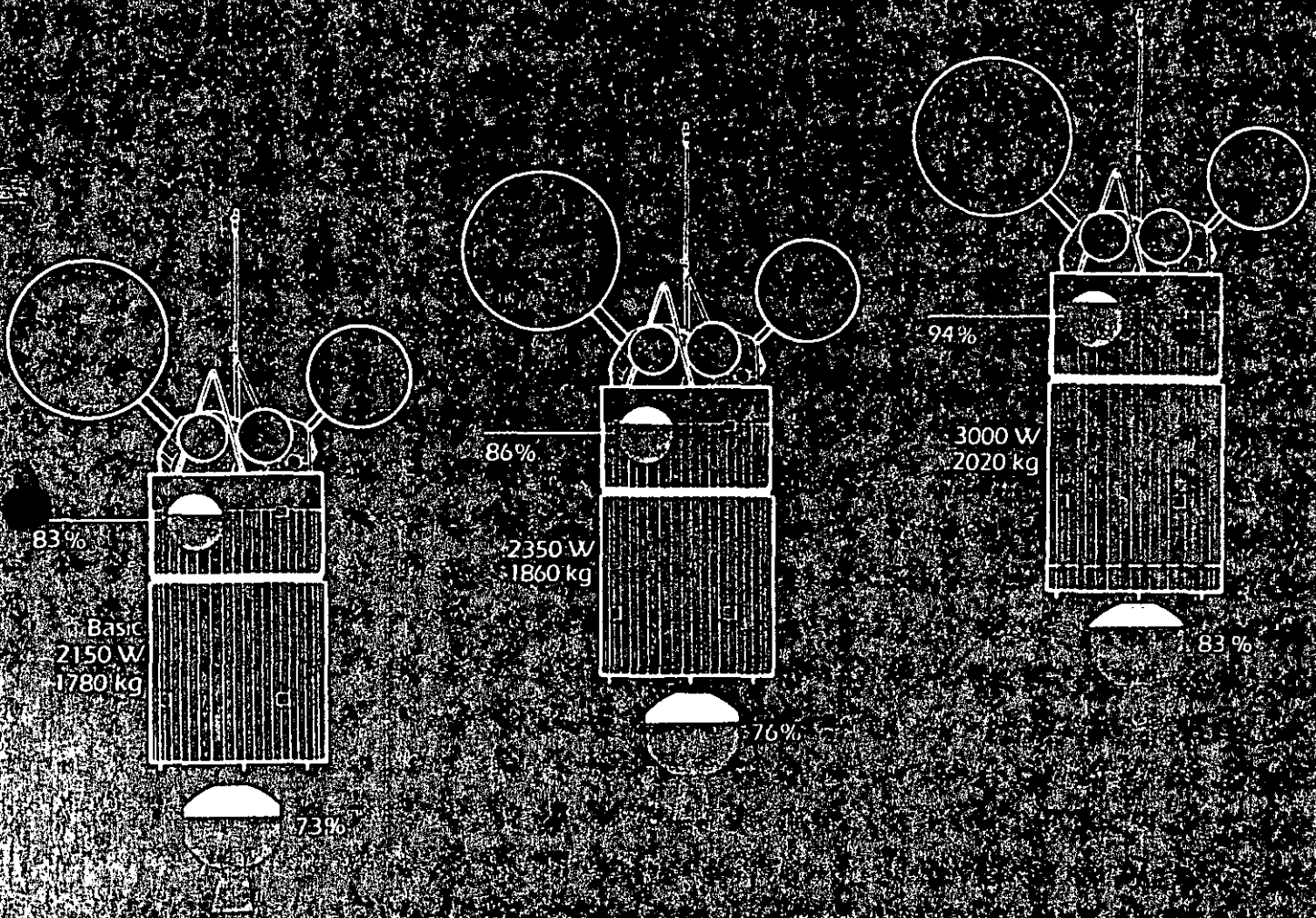
The cylindrical telescoping solar panel allows convenient growth, compact storage, and selection of optimal solar cell types for fixed and deployable sections. Conventional K7 solar cells with a thickness slightly reduced to 200 microns are used on the telescoping panel. On the fixed panel, K4¾ cells are used because their lower solar absorptance results in a lower temperature for the spacecraft interior.

ATTITUDE DETERMINATION AND CONTROL

The attitude determination and control subsystem for Intelsat VI is based on concepts and techniques used on all of our previous programs. The control electronics uses microprocessor technology, to provide precision pointing control, a capability for increased spacecraft autonomy, and significant design flexibility. A precision pointing system using beacon tracking provides an additional capability for precise despin control. Pointing accuracy of $\pm 0.05^\circ$ is maintained in the beacon tracking mode; $\pm 0.10^\circ$ is maintained in the Earth/sun sensor mode.

The attitude determination and control subsystem also maintains the spacecraft attitude without ground intervention. Onboard digital time interval measurements allow calculation of spacecraft attitude either in the processor or on the ground via telemetry. When attitude error reaches preset limits, the processor automatically fires thrusters to make the required corrections. This eliminates the need for continuing real-time control of the spacecraft.

The bearing and power transfer assembly is the only connection between the spun and despun parts of the spacecraft. Similar bearings, lubricant, and motors have flown on 30 Hughes spacecraft without incident.



GROWTH CAPABILITY

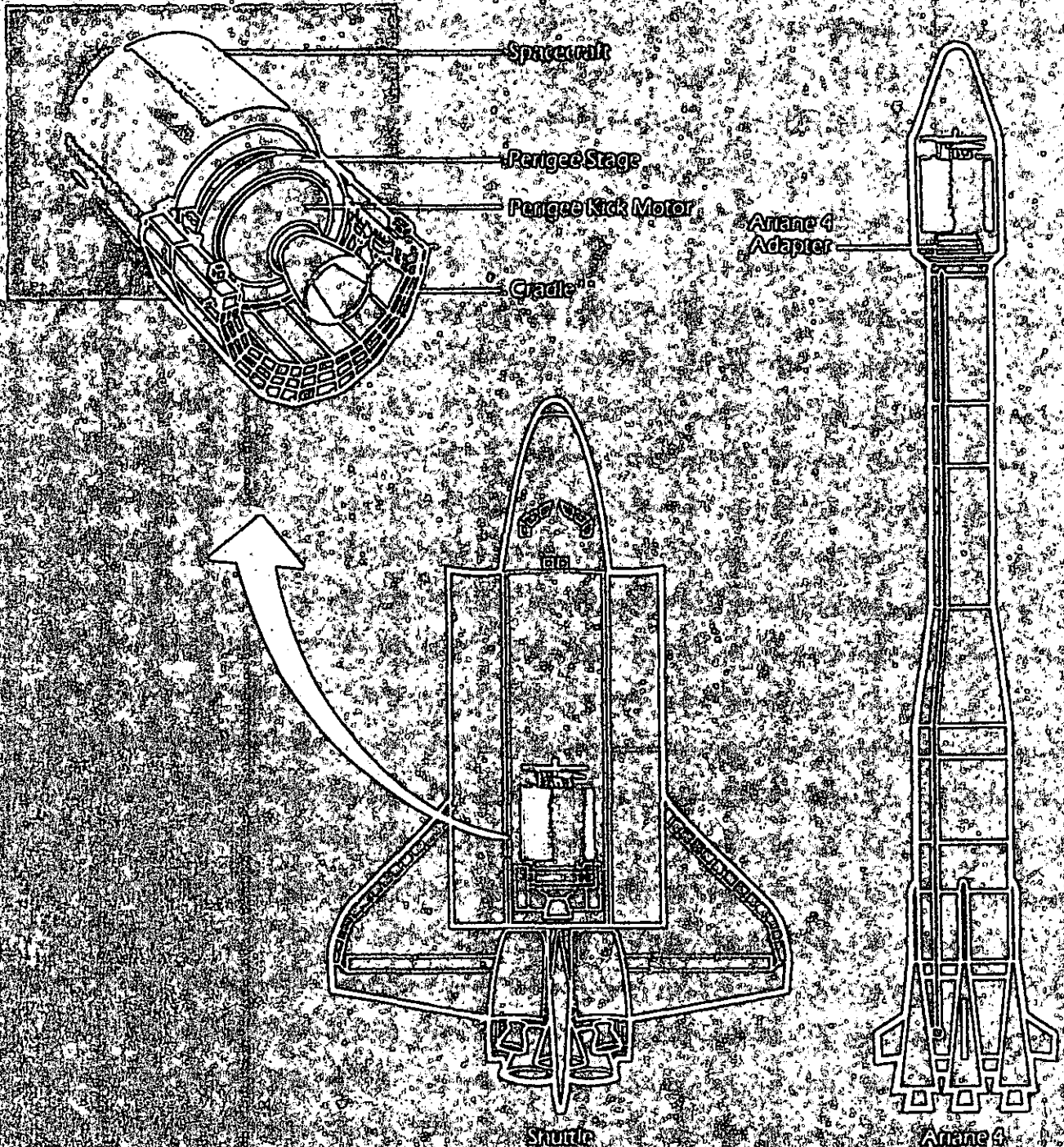
GROWTH CAPABILITY

The Intelsat VI spacecraft can grow in several steps to accommodate additional communications requirements. The fundamental reasons for the substantial growth capability are:

- The liquid propellant tanks are not fully loaded in the baseline configuration, and can be filled if necessary. The tanks can also be enlarged to support more demanding missions.
- The solid rocket motor used to insert shuttle-launched spacecraft into transfer orbit is only partially loaded (73 percent) in the baseline. With additional propellant, it can lift substantially heavier payloads.
- The solar panel can be extended significantly, providing more power.
- The thermal radiator can be lengthened to dissipate the heat generated by additional transponders needed for future missions.
- The spacecraft design allows room for additional communications equipment, both in the antenna arrangement and on the electronics shelves.

A number of growth features for Intelsat VI have been incorporated at the outset. The first significant growth step involves using the capability built into the payload structure and power subsystem. With higher efficiency thin solar cells now in pilot production, the spacecraft can support 2350 watts and 1860 kg for a 10-year life spacecraft.

The second growth step increases this capability to 2020 kg and 3000 watts by using the growth capability built into the propulsion subsystem, perigee motor, and cradle. This spacecraft uses the full capability of an Ariane 4 booster which can place 4200 kg into transfer orbit.



INTELSAT VII LAUNCH CONFIGURATIONS

LAUNCH AND DEPLOYMENT

For both shuttle and Ariane launch, the spacecraft folds into a compact configuration. The antennas are folded down and in, and the aft solar array is telescoped up. This arrangement minimizes cantilever loads acting on the spacecraft during launch. The antennas and solar array are deployed to their operational positions by ground command after the spacecraft is on-orbit, as shown in the sequence. The spacecraft's attach interface is common to both Ariane and the shuttle.

Ariane

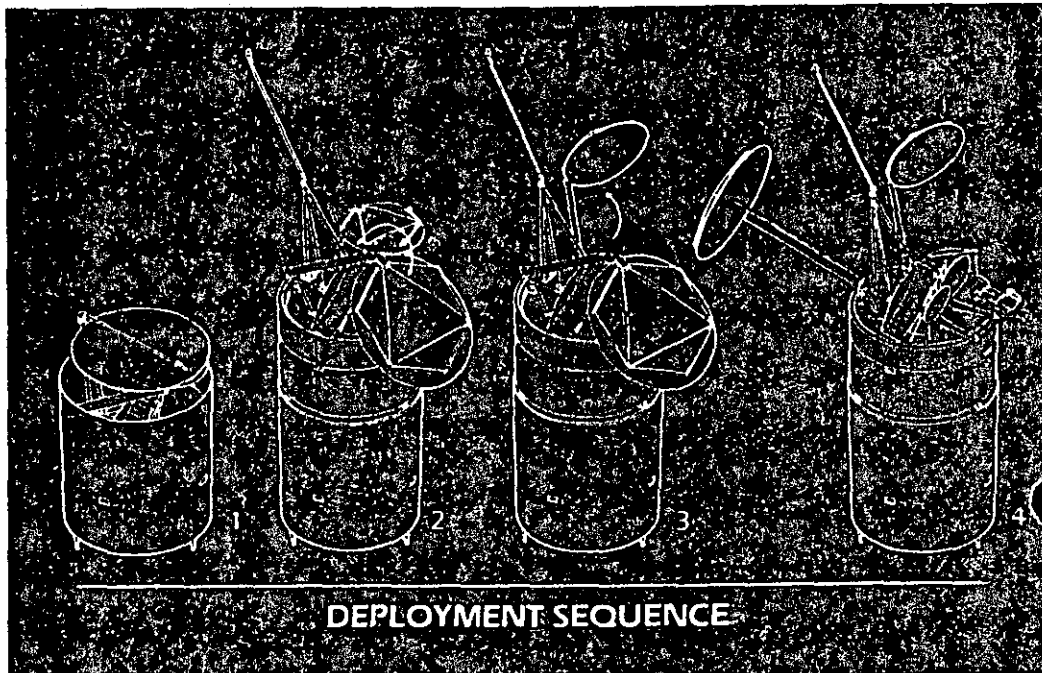
The satellite, which fits comfortably in the 9.8-meter Ariane fairing, is mated to the booster with a conical adapter and clamp. The Ariane launcher provides an initial spin of several rpm before the spacecraft is separated. This provides adequate stability until signals from the spacecraft are received at the ground station in Australia. At that point, full spinup is commanded from the ground.

Shuttle

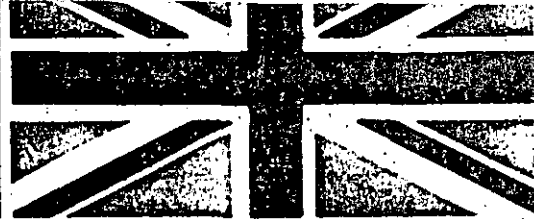
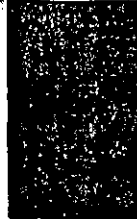
For shuttle launch, the overall length of the spacecraft and perigee stage is well matched with weight—both are approximately 45 percent of orbiter capacity. A perigee propulsion stage injects the spacecraft into synchronous transfer orbit from the shuttle's low Earth orbit. A cradle provides the shuttle interface.

The spacecraft is ejected from the shuttle using a Frisbee method which also provides the initial spinup. Thrusters commanded by a spacecraft sequencer

perform the final spinup. This occurs after the satellite has reached a safe distance from the shuttle. Soon after, the sequencer fires the perigee kick motor (PKM). The PKM motor case is then ejected from the satellite.



1. Launch Configuration
2. Solar Panel Extended
3. Transmit Reflector Unfolded
4. All Antennas Deployed



THE HUGHES INTERNATIONAL TEAM

Because of the magnitude of the Intelsat VI program, international industrial support is essential. At its peak, the program effort requires 2400 space specialists. Hughes will dedicate 1000 of its personnel to this effort; the subcontractors will provide the rest.

Our Intelsat team has partners in Canada, France, Germany, Great Britain, Italy, Japan, and the United States. They are designing and manufacturing communications repeater units and antennas for the payload. They are also providing mechanical and electronic units for the spacecraft bus. A description of the division of work among the specific companies follows.

United States

As the prime contractor for Intelsat VI, Hughes is providing systems engineering and spacecraft assembly, integration, and test. We are doing so at our main facility in El Segundo, California. We are also designing and manufacturing a variety of units and subsystems for both the payload and the bus. Our subsidiary, Spectrolab, is providing solar cells for the aft solar array. C band traveling wave tubes are coming from another Hughes group.

Facilities located near SCG will be used for solar thermal-vacuum tests of the thermal model as well as spacecraft acoustic tests. All other qualification and acceptance tests will be conducted at the SCG facility in El Segundo. This concern-

tion of facilities, equipment, and people enables the program office to coordinate activities on a daily basis.

Canada

Spar Aerospace Ltd. is providing C band communications receivers, driver amplifiers, and TWTAs. It is also providing spacecraft bus hardware, particularly digital electronics, and is committing 300 of its people to the task.

Spar has a substantial background in satellite manufacture. It has furnished equipment to Hughes for Intelsat, Canadian, and American domestic programs for over a decade. It has built structures, thermal barriers, mechanisms, batteries, units for power electronics, digital command and telemetry, controls, RF command and telemetry, TWTAs, communications receivers, antennas, and wire harnesses. Spar is the prime contractor for the Anik D domestic satellite program for Telesat Canada. It has also been selected recently by Embratel of Brazil to build that country's first satellite to a Hughes design.

COMDEV, Ltd. of Canada is supplying microwave output filters. It has provided such equipment for many Hughes programs in the past decade.

France

Thomson-CSF has allocated 200 people to the Intelsat program. Its Space Division will design, manufacture, and test much of the C and K band communications receivers and C band output multiplexers. The Space Division is presently building the C and K band TELECOM I communications satellite payload. This experience is directly applicable to Intelsat VI.

Its Electron Tube Division is designing, manufacturing, and testing K band traveling wave tubes for Intelsat VI.



T-CSF has previously furnished K band tubes for a number of space programs, including Intelsat V and TELECOM I. The tubes we are using are slight modifications of those delivered for Intelsat V.

Germany

Messerschmitt-Boelkow-Blohm (MBB) is designing and fabricating the solar array. A staff of 250 employees is assigned to the program at its Ottobrun plant in Munich. The company has significant experience in the development and fabrication of solar arrays and is a leader in the production of composite and sandwich structures.

AEG-Telefunken is supplying cells for the forward panel of the solar array.

Great Britain

British Aerospace (BAe) has a major role in Intelsat VI. It is designing and building the complete shuttle cradle and carrier. BAe is also responsible for the power and signal interface units between the shuttle and the Intelsat VI spacecraft. It is also designing and building antenna reflectors at C and K band. It is building spacecraft structures and wire harnesses to our design. BAe is also designing and building the adapter for the Ariane launcher. This work is being done by 80 people at BAe's Stevenage and Bristol facilities.

Italy

Selenia is responsible for the telemetry transmitters and command receivers, telemetry and command bicone antenna, remote and central telemetry units, K band beacon horn, and spot beam antennas. The work includes design, manufacturing, and testing. Selenia is

also manufacturing C band global and telemetry horns. It has assigned 100 people at its Rome facility to the program.

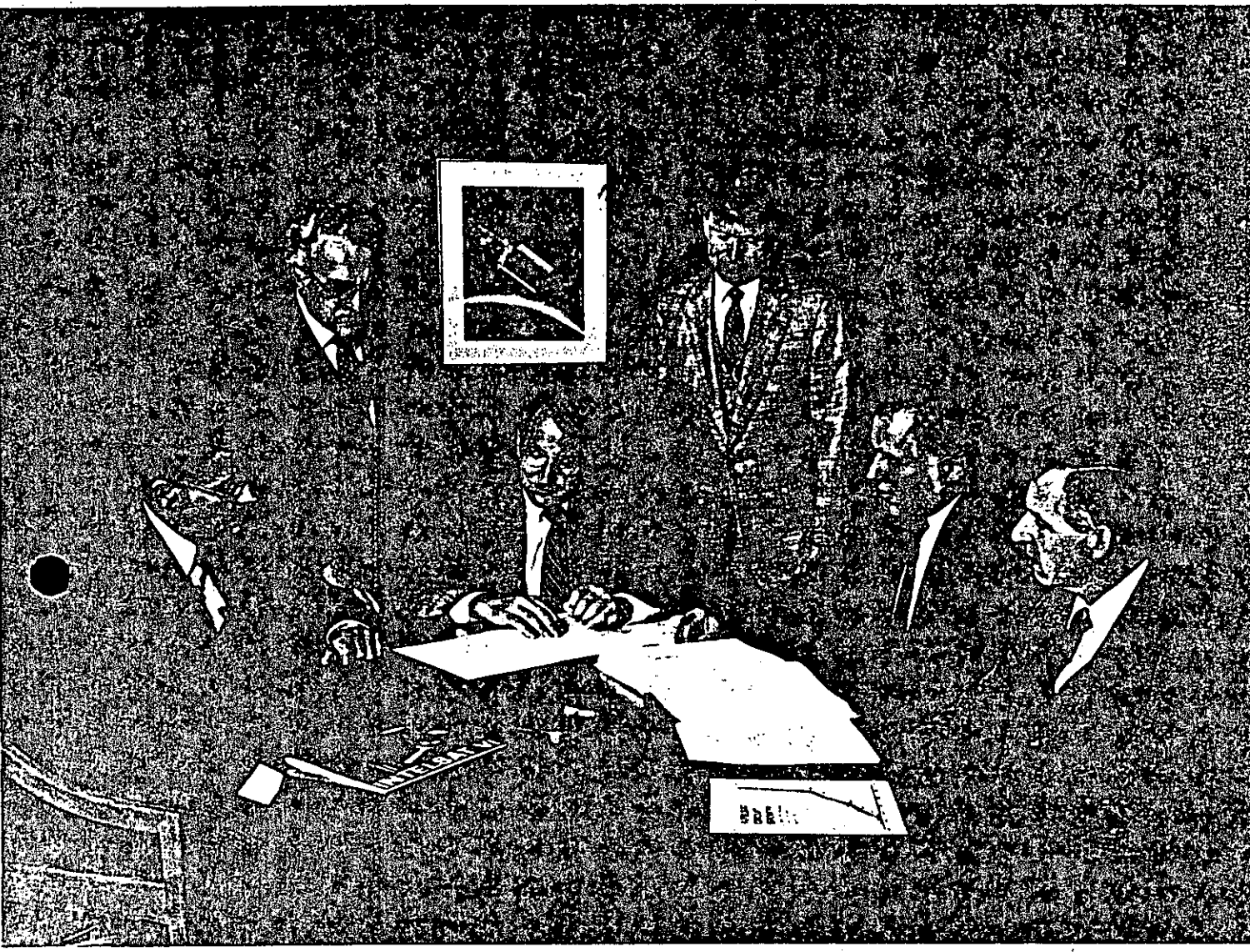
Selenia provided antennas and antenna positioning mechanisms for Intelsat IV and global horn antennas for Intelsat IVA. It has since expanded its space hardware capabilities to include antenna systems at C and K bands, TT&C, and data handling equipment. The company has supplied this equipment to most ESA programs and to Intelsat V.

Japan

Nippon Electric Company (NEC), with 400 of its employees, is designing, manufacturing, and testing K band communications receivers, upconverter amplifiers, master oscillators, a distribution unit, and solid state power amplifiers. In each case NEC is offering hardware that is already in advanced stages of development.

NEC has been a major contributor to Japanese space programs and to Intelsat programs since the mid-1960s. NEC built a complete repeater subsystem for Intelsat IV. It fabricated, assembled, and tested communications receivers, and multiplexers for Intelsat IV and IVA.

PROGRAM MANAGEMENT



Intelsat VI program manager Dave Braverman, seated center, with his senior management team. His associate program manager, Mal Meredith, is second from right. His assistant program managers are, from left, Henry DiCristina, Ted Savo, Dave Doyle, and, far right, Jerry Dutcher.

INTELSAT

The International Telecommunications Satellite Organization (INTELSAT) provides international commercial communications by satellite to all areas of the world. It was established by treaty in 1964 and today has 106 member countries. It is an international cooperative in which the members provide capital for new space facilities in proportion to their use of the system. The cost, operating expenses, and depreciation of the system are shared among the users in proportion to their use. INTELSAT consistently returns 14 percent on the invested capital. Countries who are not members of INTELSAT can use the system for a fee. Some member nations lease excess satellite capacity to provide telecommunications service for their own domestic needs.

The space segment is owned in common by the members. In the 18 years of operation, they have invested over \$1.3 billion in this space segment, buying and launching 33 spacecraft. The 398 ground stations that access the INTELSAT system are owned individually by the member nations in which they are situated. The ground segment represents a member investment of over \$2 billion.

	Number	Supplier	First Flown
Intelsat I	2	Hughes	Apr 1965
Intelsat II	5	Hughes	Oct 1966
Intelsat III	8	TRW	Sep 1968
Intelsat IV	8	Hughes	Jan 1971
Intelsat IVA	6	Hughes	Sep 1975
Intelsat V	9	Ford	Dec 1980
Intelsat VA	6	Ford	End 1983
Intelsat VI	5*	Hughes	1st half 1986

*Initial production quantity

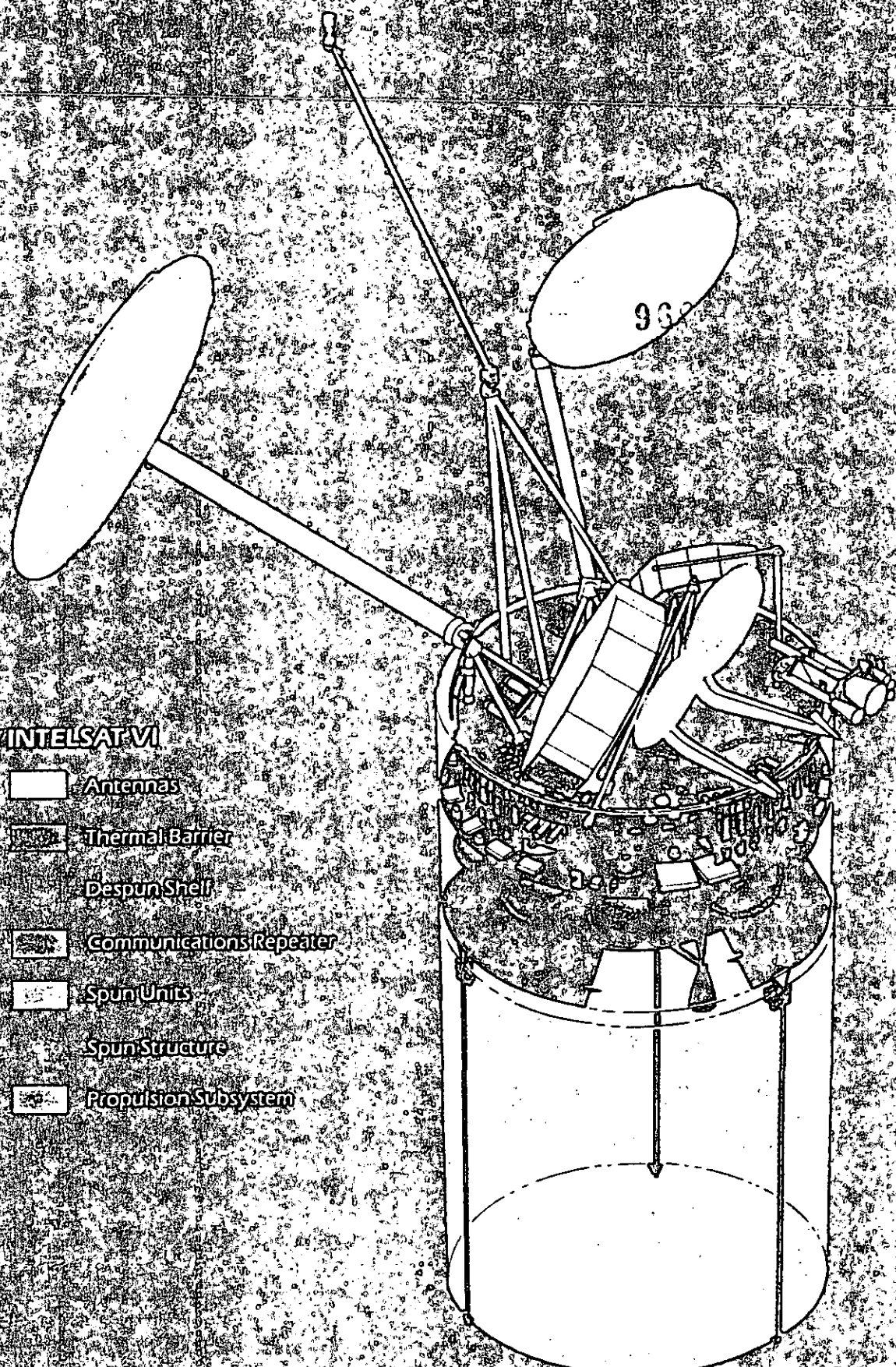
Member countries with investment share of 1 percent or greater*

United States	24.0	Spain	1.9
United Kingdom	13.2	United Arab Emirates	1.7
France	5.8	Nigeria	1.5
Germany	3.5	Switzerland	1.3
Australia	3.4	Venezuela	1.3
Japan	3.0	South Africa	1.2
Brazil	3.0	Argentina	1.1
Saudi Arabia	3.0	Singapore	1.1
Canada	2.4	Iran	1.1
Italy	2.3	Netherlands	1.0

*As of 1 March 1982

INTELSAT VI

- Antennas
- Thermal Barrier
- Despun Shelf
- Communications Repeater
- Spun Units
- Spun Structure
- Propulsion Subsystem



**8.- ESPECIFICACION, ADQUISICION E INSTALACION
DE ESTACIONES TERRENAS.**

ETAPAS DE PROYECTO

* DEFINICION DEL PROYECTO

- DEFINICIÓN DE REQUERIMIENTOS
- ESTUDIOS DE FACTIBILIDAD

* ESPECIFICACIONES DEL SISTEMA

- ELABORACIÓN DE ESPECIFICACIONES
- EVALUACIÓN DE PROPUESTAS
- DECLARACIÓN DE TRABAJO

* IMPLANTACION DEL PROYECTO

- PLAN DE INSTALACIÓN
- PUESTA EN MARCHA

ESPECIFICACION DEL SISTEMA

NECESIDADES.

* CAPTURA DE NECESIDADES DE COMUNICACION

- CANALES DE VOZ

- . PRIORIDAD
- . GRADOS DE SERVICIO
- . PUNTOS A ENLAZAR
- . REDUNDANCIA
- . MODO Y TERMINACIÓN DE CANAL
- . SEÑALIZACIÓN

- CANALES DE DATOS

- . PUNTOS A ENLAZAR
- . VELOCIDAD DE TRANSMISIÓN
- . PROBABILIDAD DE ERROR (P_e)
- . TIEMPO DE OCUPACIÓN DE CANAL
- . REDUNDANCIA
- . MODO Y TERMINACIÓN DE CANAL

- CANALES DE VIDEO

ESPECIFICACION DEL SISTEMA

* CONTENIDO

- DESCRIPCIÓN GENERAL DEL PROYECTO
- TÉRMINOS Y CONDICIONES
- ESPECIFICACIÓN TÉCNICA DE EQUIPOS
- ALCANCE DEL SUMINISTRO
- CUESTIONARIOS

* DESCRIPCION GENERAL

- OBJETIVOS GENERALES
- NECESIDADES A SATISFACER
- REQUERIMIENTOS OPERATIVOS GENERALES
 - . FRECUENCIAS
 - . CONFIABILIDAD
 - . CANALIZACIÓN
 - . SUPERVISIÓN Y MANTENIMIENTO

ESPECIFICACION DEL SISTEMA

* ESPECIFICACION TECNICA

- REGLAS GENERALES

- . QUE NO TENGA MUCHAS OPCIONES
- . NO MUY DETALLADA (GENERAL Y FUNCIONAL)
- . NO CENTRADA ALREDEDOR DE UN VENDEDOR
- . QUE TENGA UNA TABLA DE CUMPLIMIENTO
- . QUE CONSIDERE EXPANSIONES
- . REQUERIMIENTOS DE AMPLIA INFORMACIÓN

- ESPECIFICACIÓN GENERAL DE LOS EQUIPOS

- . CARACTERÍSTICAS DE DISEÑO
 - . ESTADO SÓLIDO
 - . PUNTOS DE PRUEBA
 - . BUENA INGENIERÍA
- . ACABADOS
- . ACCESORIOS
- . CONDICIONES AMBIENTALES
 - . TEMPERATURA
 - . INTERFERENCIA ELECTROMAGNÉTICA
 - . HUMEDAD

ESPECIFICACION DEL SISTEMA

* TERMINOS Y CONDICIONES

- CONTROL DE AVANCE Y TIEMPOS DE ENTREGA
 - . RETRASO
 - . AMPLIACIONES
- PENALIZACIONES Y FIANZAS
- MODIFICACIONES Y ADICIONES
- GARANTÍAS
 - . OPERACIÓN
 - . CALIDAD
 - . REFACCIONES
- INSPECCIONES Y PRUEBAS
 - . FÁBRICA
 - . PUESTA EN SERVICIO
- EMBARQUES, EMPAQUES Y ALMACÉN
- PROGRAMA DE PAGOS
 - . MONEDA
 - . COSTOS FIRMES Y VARIABLES
 - . LUGAR
 - . VIGENCIA
- OTROS ASPECTOS
 - . IMPUESTOS
 - . PERMISOS

ESPECIFICACION DEL SISTEMA
EVALUACIÓN DE PROPUESTAS

* INVITACION A CONCURSO

- SELECCIÓN DE PARTICIPANTES
- NÚMERO

* SELECCION DEL PROVEEDOR

- CALIFICACIÓN DE DEFICIENCIAS
- PUNTUACIÓN
- ENTREVISTAS ACLARATORIAS
- CARTAS DE INTENCIÓN

* DECLARACION DE TRABAJO

- ACLARACIONES DETALLADAS
- ACTUALIZACIÓN DE LA ESPECIFICACIÓN
- CONOCIMIENTO DETALLADO DEL SISTEMA A ADQUIRIR
- BASES PARA EL CONTRATO
- CONDICIONES DETALLADAS DE
 - . IMPLANTACIÓN
 - . CAPACITACIÓN
 - . PRUEBAS EN FÁBRICA
 - . INSTALACIÓN
 - . PUESTA EN MARCHA

SUGERENCIAS PARA LA EVALUACION DE PROPUESTAS DE PROVEEDORES DE EQUIPO.

Las sugerencias aquí indicadas deberán aplicarse a cada proveedor para poder evaluar sus propuestas sobre una base costo-beneficio. Estos comentarios no integran un grupo exhaustivo, pero se consideran como los más importantes.

Comentarios generales.

- 1) Debe darse preferencia a equipo que haya sido probado y empleado en otros sistemas.
El ofrecimiento de productos novedosos que ahorren potencia, ancho de banda, o algún otro parámetro, puede ser engañoso, ya que puede tratarse de una técnica o componente conocida, bautizada con distinto nombre.
- 2) Debe evitarse al máximo la interconexión excesiva de módulos de fabricantes distintos. Esto puede causar problemas no sólo de acoplamiento, sino de mantenimiento y reposición.
- 3) Debe exigirse a los proveedores que presenten y entreguen:
 - a) una descripción detallada de la integración del sistema con cálculos y sumas de niveles de potencia.
 - b) especificaciones detalladas de todo el equipo, indicando que cumplen con los estándares de INTELSAT.
 - c) consideraciones sobre mantenimiento, repuestos y confiabilidad.

* si es que piensa usarse un satélite INTELSAT.

- d) programa de entrega del equipo con un calendario que satisfaga las necesidades del comprador.
 - e) descripción de las responsabilidades del fabricante y del cliente en cuanto a instalación, incluyendo un plan de tiempos, costos y cobertura de estos últimos.
 - f) un plan de pruebas para todo el equipo, indicando al responsable de realizarlas.
- 4) La evaluación de propuestas debe hacerse sobre una base costo-beneficio y no comparando costos únicamente.

Aspectos generales a analizar en las propuestas.

- 1) Checar los siguientes parámetros en los cálculos que presente el proveedor:
 - a) márgenes de operación.
 - b) G/T especificados para los peores casos.
 - c) niveles de señal y de ruido para todas las estaciones, para los peores casos.
 - d) productos de intermodulación en los canales SCPC* y elección del tamaño de los amplificadores de potencia, tomando en cuenta una futura expansión. Back-offs de operación.
 - e) estabilidad en los niveles de transmisión
 - f) respuestas de transmisión y recepción del equipo SCPC, o de portadora con canal múltiple.
 - g) tolerancias de frecuencia en recepción y transmisión.

* ó FDM.

h) temperatura de ruido de los receptores.

2) Las especificaciones del equipo e instalaciones bajo condiciones de operación deben tomar en cuenta los parámetros de:

- a) humedad
- b) precipitación pluvial
- c) velocidad del viento
- d) posible interferencia

Aspectos detallados a analizar en las propuestas, por componente.

Es muy probable que las propuestas presentadas por los proveedores contengan mucha información superflua o poco crítica. A continuación se indican los principales parámetros o puntos clave considerados como necesarios, y en los que hay que prestar particular atención, bajo la suposición de que se desea operar inicialmente con el INTELSAT IV, en modo SCPC.

1) Antenas.

a) lóbulos laterales. El patrón de radiación debe cumplir con las especificaciones de INTELSAT/CCIR:

para $1^\circ < \theta < 48^\circ$, ganancia = $32 - 25 \log \theta$

para $48^\circ < \theta < 100^\circ$, ganancia = -10 dBi

para $100^\circ < \theta < 180^\circ$, ganancia = -15 dBi

en donde el ángulo θ se mide a partir de la dirección de máxima radiación (lóbulo principal).

b) polarización. El satélite INTELSAT IV opera con polarización circular. Debe analizarse la previsión propuesta para un posible cambio a polarización lineal, en caso de necesitar operar con un satélite americano. El proveedor debe garantizar o demostrar una discriminación de polarización cruzada en polarización lineal mayor o igual a 30 dB.

c) tolerancias de superficie. El proveedor debe indicar:

- la precisión del reflector
- la eficiencia de operación bajo condiciones

-470

de viento y radiación solar.

- la precisión del subreflector.
- características de distorsión
- métodos para soportar la estructura.
- transportación, protección y ensamblado.

d) rastreo. El proveedor debe indicar la precisión del mecanismo o método de rastreo, velocidad de movimiento, señalización y operación bajo condiciones de viento. Es muy importante prever desplazamientos significativos del INTELSAT IV por el tiempo en que ya ha estado operativo y el proveedor debe indicar soluciones al respecto. Debe considerarse además la complejidad mecánica de las cajas de engranes y dispositivos asociados.

También es muy importante que el proveedor especifique la disponibilidad y entrega de paneles de observación con indicadores de alarma, sensores de posicionamiento y de pérdida de la señal, así como los requerimientos de potencia para alimentar a todo el sistema de rastreo. Transferencia automática a operación manual en caso necesario.

e) patrones de radiación de los alimentadores. El proveedor debe especificarlos y garantizar eficiencia máxima e interferencia mínima, para toda la banda de frecuencias de transmisión y recepción.

f) VSWR. El proveedor debe especificarlo para toda la banda de frecuencias de transmisión y recepción. Debe estar lo más cercano posible a 1.0.

g) aislamiento del alimentador. Debe cumplir con lo siguiente:

transmisión/recepción > 80 dB

recepción/recepción > 30 dB

transmisión/transmisión > 30 dB

h) potencia capaz de manejar la antena. Deber ser mayor o igual a 1.5 veces la salida máxima nominal del amplificador.

i) protección del alimentador. El proveedor debe especificarla (contra polvo, corrosión, lluvia, etc.)

j) presurización de las guías de onda. El proveedor debe especificarla.

2) Amplificadores de potencia. Los puntos clave en la definición de éstos son la potencia de los productos de intermodulación para determinar la potencia máxima nominal de cada tubo de onda progresiva (es decir, back-offs), el control de estabilidad en la salida y las emisiones espurias y ruido (especialmente ruido de fase). Las características de cada amplificador deben ser comparables a las siguientes:

a) VSWR bajo condiciones de carga. Debe ser menor o igual a 1.5:1.

b) pendiente de la característica de ganancia. Debe ser menor o igual a 0.03 dB/MHz cuando menos en un tercio de la banda, tomando como punto de referencia la frecuencia central.

c) salidas espurias. Deben ser menores o iguales a -65 dBW en cualquier banda de 4 kHz.

d) productos de intermodulación de tercer orden. Para pruebas con dos portadoras debe uno esperar

valores aproximados a los siguientes:

productos de intermodulación (dB)	back-off salida (dB)
-10	3
-25	10
-40	17

e) retraso de grupo. Debe uno esperar valores como los siguientes:

lineal ≤ 0.25 nseg/MHz
 parabólico cuadrado ≤ 0.5 nseg/MHz
 rizo, pico-pico ≤ 2 nseg, en cualquier banda de 36 MHz.

f) conversión de AM a PM. Debe ser aproximadamente igual a:

$< 6^\circ/\text{dB}$ para amplificadores con potencia nominal de salida de 3 kW.
 $< 4^\circ/\text{dB}$ para potencia nominal de salida de 1.5 kW.
 $< 3^\circ/\text{dB}$ para amplificadores más pequeños.

Estos valores son para operación con una sola portadora y back-off de 6 dB.

g) salidas armónicas. Su potencia total debe ser inferior a 30 dB por debajo de la potencia nominal de salida del amplificador.

h) filtro de armónicas de la guía de onda. Es importante que el filtro de armónicas tenga una buena característica de supresión con atenuaciones del orden siguiente:

segunda armónica: 50 dB, mínimo
 tercera armónica: 40 dB, mínimo
 demás armónicas: 30 dB, mínimo.

- i) potencia de alimentación. Deben especificarse las variaciones permisibles en el voltaje y frecuencia de alimentación (valores razonables son, respectivamente, $\pm 10\%$ y $\pm 5\%$). Debe especificarse si se requiere algún sistema especial de alimentación, protección y circuitos de arranque - parada.
- j) sistema de enfriamiento. Usualmente contiene un soplador de hélice. Cualquier falla de este soplador debe advertirse con un sistema de alarma.
- k) controles, medidores y seguros de protección. Todos estos deben ser provistos para conocer el estado de operación en la consola de control.
- l) condiciones de operación. Debe especificarse el rango de temperaturas, humedad, altitud y vibraciones (en caso de transporte).
- m) condiciones de reparación y entrega. Deben ser especificadas.
- 3) Preamplificadores de bajo ruido. Deben ser de configuración redundante, completos con switches de RF, filtros, acopladores, placa de montaje y unidad de control.
- a) ganancia. Debe ser del orden de 50 a 55 dB en un ancho de banda de 500 MHz y acorde con la temperatura de ruido requerida.
- b) pendiente de la característica de ganancia.
Debe ser $\leq \pm 0.2$ dB en cada 10 MHz
Debe ser $\leq \pm 0.5$ dB en toda la banda de 500 MHz.

c) estabilidad de ganancia. Este parámetro es muy importante y debe ser especificado. Valores típicos de estabilidad son:

± 0.2 dB por día.

± 0.5 dB por semana.

d) temperatura de ruido. Debe checarsse de acuerdo a cada estación. Es muy importante asegurarse que la cifra suministrada incluye las contribuciones del switch de entrada, el acoplador y el filtro de rechazo de transmisión, ya que atenuaciones extra de aproximadamente 1 dB pueden significar un aumento del orden de 20° en la temperatura de ruido efectiva.

e) VSWR. Debe ser menor o igual a 1.25:1 tanto en la entrada como en la salida. Tanto los cables como los conectores deben de estar incluidos.

f) retraso de grupo. Para cualquier segmento de 40 MHz dentro de la banda de recepción, debe cumplirse lo siguiente:

- lineal, $\leq \pm 0.1$ nseg/MHz

- parabólico cuadrado, $\leq \pm 0.01$ nseg/MHz²

- rizo, pico-pico, ≤ 0.5 nseg.

g) conversión de AM a PM. Debe ser menor o igual que $0.2^\circ/\text{dB}$ para niveles de portadora de entrada alrededor de -70 dBm.

h) temperaturas de operación y almacenamiento. Deben ser especificadas por el proveedor para evitar la posibilidad de condensación.

i) confiabilidad y reparación. El proveedor debe garantizar un mínimo de horas de servicio (por

ejemplo, un valor promedio de 30 a 50 mil horas), así como el tiempo de reparación y trámites requeridos.

j) sistema de conmutación. Debe proporcionarse un sistema de switcheo automático entre preamplificadores de bajo ruido, con tiempos de conmutación del orden de 100 mseg.

k) acoplador de entrada de prueba. El proveedor debe indicar las ventajas de poseer y el precio de esta unidad para checar el funcionamiento del preamplificador con regularidad.

l) filtro de rechazo de transmisión. Es muy importante tener este filtro para rechazar la potencia de fuga del transmisor. Debe tener una capacidad de rechazo de 80 a 90 dB en la banda de transmisión.

4) Convertidores de frecuencia (mezcladores). Los convertidores de frecuencia (70MHz a 6 GHz. v 4GHz a 70MHz) generalmente se encuentran integrados con el equipo SCPC, y consisten de amplificadores, mezcladores, filtros y osciladores locales.

4.1) convertor de bajada. Debe cumplir con los siguientes parámetros:

a) VSWR, entrada, $\leq 1.2:1$.

b) factor de ruido ≤ 12 dB

c) ganancia $\approx 55 \pm 10$ dB

d) nivel de potencia de salida ≈ -34 dBm para entrar a la tarjeta de SCPC.

e) ruido de fase; esta es una característica muy importante. A continuación se dan algunos valores típicos.

frecuencia fundamental, $1^\circ/\text{KHz}$
 segunda armónica, $0.5^\circ/\text{KHz}$
 tercera armónica, $0.5^\circ/\text{KHz}$.

f) estabilidad de frecuencia $\approx \pm 4 \text{ ppm/mes}$

4.2) convertor de subida. Debe cumplir con los siguientes parámetros:

a) VSWR, entrada $\leq 1.2:1$

b) variación de ganancia con temperatura. Provista por el proveedor.

c) variaciones en la respuesta de amplitud en cualquier banda de $\pm 20 \text{ MHz}$ $\approx \pm 0.2 \text{ dB}$.

d) ruido de fase igual a 4.1.e.

e) estabilidad de frecuencia $\approx 0.035 \text{ ppm/mes}$ para operación entre 20° y 35°C

f) nivel de potencia de salida ≈ -35 a -28 dBm para entrar a la tarjeta de SCPC.

Debe asegurarse la entrega y continuación de manufactura de cristales de repuesto para ambos conversores, subida y bajada. La estabilidad de frecuencia debe ser observada en el panel de control. El proveedor debe además garantizar y demostrar que los filtros cumplen con la máscara estandarizada de INTELSAT.

5) Tarjetas de SCPC y multiplexores. Estas unidades deberán ser analizadas en función de la técnica de modulación empleada (velocidad en kbits/seg, relación s/n, BER, señal piloto, etc. y de los acoplamientos que el proveedor sugiera entre las unidades terminales remotas y las tarjetas de SCPC.

INGENIERIA DEL SISTEMA CALIF. MAX. 100 PUNTOS

	PUNTUACION MAXIMA	PROVEEDOR 1	PROVEEDOR 2	PROVEEDOR 3
C/No	10			
BER	10			
G/T	10			
Diámetro de antena	10			
BO satélite	10			
BO E/T	10			
Margen de operación	10			
Temp. LNA	10			
Pot. HPA (estado sólido)	10			
% potencia del satélite	10			
% ancho de banda del satélite	10			
TOTAL	100			

477

988

18.

IMPLANTACION DEL PROYECTO

PLAN DE IMPLANTACION

- RESPONSABILIDAD DEL USUARIO
 - . DISPONIBILIDAD DE PERSONAL
 - . CAPICITACIÓN
 - . ESTUDIOS DE CAMPO
 - . CONSTRUCCIÓN
 - . INSTALACIONES Y AJUSTE
 - . PREPARACIÓN DE SITIOS
 - . CAMINOS
 - . CASETAS
 - . ALIMENTACIÓN
 - . REVISIÓN Y ACEPTACIÓN DE DOCUMENTOS
 - . DIBUJOS
 - . CARACTERÍSTICAS DE FINANCIAMIENTO
 - . FACILIDADES REQUERIDAS
 - . SOLICITUDES DE INFORMACIÓN

IMPLANTACION DEL PROYECTO

- PRUEBAS EN FÁBRICA
 - EQUIPOS
 - SISTEMAS

 - PREPARACIÓN PARA RECIBIR EL EQUIPO
 - DESCARGA
 - TRANSPORTE

 - INSTALACIÓN Y AJUSTE

 - ACEPTACIÓN DEL SISTEMA

 - RESPONSABILIDAD DEL PROVEEDOR
 - ESTUDIOS DE CAMPO
 - FABRICACIÓN DE EQUIPO Y MATERIALES
 - TRANSPORTE
 - CAPACITACIÓN
 - DOCUMENTACIÓN COMPLETA
 - PRUEBAS DE FÁBRICA
 - PREPARACIÓN DE EMBARQUE
 - INSTALACIÓN Y AJUSTE
 - ENTREGA DEL SISTEMA
 - GARANTÍA
-

IMPLANTACION DEL PROYECTO

CAPACITACION

- PUNTOS IMPORTANTES

- . PLANEADA DESDE LOS INICIOS DEL PROYECTO
- . DEBE INICIARSE LO MÁS PRONTO POSIBLE
- . ASIGNARLE RECURSOS ECONÓMICOS
- . ASIGNAR DOS PERSONAS POR AREA AL MENOS (SI SE TRATA DE UNA RED)
- . ENTRENAMIENTO EN FÁBRICA
- . ENTRENAMIENTO EN CAMPO

- CAPACITACIÓN ORIENTADA A:

- . NECESIDADES ESPECÍFICAS DE LA EMPRESA
- . DE ACUERDO CON POLÍTICAS DE OPERACIÓN Y MANTENIMIENTO
- . A TODO EL PERSONAL INVOLUCRADO
- . RECLUTAMIENTO Y SELECCION.

- DEFINICIÓN DE CURSOS Y PROGRAMAS

- . DURACIÓN
 - . PERSONAL
 - . CONTENIDO
 - . LUGAR
 - . FACILIDADES
-

IMPLANTACION DEL PROYECTO

PRUEBAS DE ACEPTACION EN FABRICA

- PUNTOS IMPORTANTES

- DEBE SER DEFINIDA Y ACEPTADA ANTES DE INICIARSE
- CADA PRUEBA DEBE SER ACEPTADA POR ESCRITO.
- FALLAS ESPECÍFICAS DEBEN SER IDENTIFICADAS POR ESCRITO Y CORRECCIONES DEBEN DE SER ACEPTADAS CON PRUEBAS.
- PRUEBAS AL EQUIPO
- PRUEBAS AL SISTEMA
- ASIGNARLES TIEMPO NECESARIO Y RECURSOS
- NO PERMITIR EL ENVIO DEL EQUIPO HASTA SU ACEPTACIÓN DEFINITIVA.

INSTALACION Y PUESTA EN MARCHA

INSTALACION

- LLEGADA DEL EQUIPO

- . INSTRUCCIONES DE MANEJO
- . IDENTIFICACIÓN Y LOCALIZACIÓN
- . DISPONIBILIDAD DE EQUIPO PARA DESEMPAQUE
- . PLAN DE TRANSPORTACIÓN

- PREPARACIÓN DE SITIOS

- . INSTALACIÓN EXTERIOR
- . INSTALACIÓN INTERIOR

- MANIOBRAS

. INSTALACIÓN CON PERSONAL PROPIO

- . CAPACITACIÓN
- . DOCUMENTACIÓN
- . SUPERVISIÓN DEL PROVEEDOR
- . CERTIFICACIÓN

. INSTALACIÓN CON PERSONAL DEL PROVEEDOR

- . DOCUMENTACIÓN
- . CAPACITACIÓN INTERNA
- . COSTO

INSTALACION Y PUESTA EN MARCHA

PUESTA EN MARCHA

- AJUSTE DE ESTACION
 - DIAGNÓSTICO DE EQUIPO
 - REPARACIÓN Y CORRECCIÓN
 - AJUSTE FINAL

- AJUSTE DEL SISTEMA
 - DIAGNÓSTICO DEL SISTEMA
 - AJUSTES

- ENTREGA
 - SUPERVISIÓN DE PROVEEDOR
 - INICIACIÓN DE GARANTÍA

- GARANTÍA
 - OPERACIÓN
 - CALIDAD
 - REFACCIONES

MANTENIMIENTO Y SUPERVISION

ORGANIZACION DEL MANTENIMIENTO

- AREAS DE COBERTURA
- LOCALIZACIÓN DE CENTROS DE MANTENIMIENTO Y REPARACIÓN
- NIVEL DE MANTENIMIENTO (ESTADÍSTICAS DEL PROVEEDOR)

MÓDULO

TARJETA

COMPONENTE

- LOTE DE EQUIPO DE PRUEBA, REPARACIÓN HERRAMIENTA COMPONENTES
- PERSONAL Y CAPACITACIÓN
- DOCUMENTACIÓN
- CONTRATACIÓN DE MANTENIMIENTO
 - REPRESENTANTES
 - COMPAÑÍAS ESPECIALIZADAS

MANTENIMIENTO CORRECTIVO

- FILOSOFÍA DE MANTENIMIENTO
- MTTR, TIEMPO DE ESPERA, TIEMPO DE TRANSPORTE, ETC.
- SUPERVISIÓN DEL EQUIPO

485

996

MANTENIMIENTO Y SUPERVISION

MANTENIMIENTO PREVENTIVO

- CORRIDAS DE DIAGNÓSTICO
- VISITAS PERIODICAS
- AJUSTE DE NIVELES Y CALIBRACIÓN
- EQUIPO ELECTROMECÁNICO REVISIÓN Y MANTENIMIENTO GENERAL
- ALIMENTACIÓN
- LIMPIEZA

SUPERVISION

- CONDICIONES DE OPERACIÓN DEL EQUIPO
- EJERCICIOS DE ALARMAS Y CONTROLES
- ESTADÍSTICAS

ECONOMICS OF SATELLITE
COMMUNICATIONS SYSTEMS



486

ECONOMICS OF SATELLITE
COMMUNICATIONS SYSTEMS
FOR W.L. PRITCHARD
SATELLITE SYSTEMS ENGINEERING, INC.

Economics of satellite communications systems†

WILBUR L. PRITCHARD

Satellite Systems Engineering, Inc., 7315 Wisconsin Avenue, Bethesda, MD 20814, U.S.A.

(Received 5 May 1981)

Abstract—This paper is partly a tutorial, telling systematically how one goes about calculating the total annual costs of a satellite communications system, and partly the expression of some original ideas on the choice of parameters so as to minimize these costs.

The calculation of costs can be divided into two broad categories. The first is technical and is concerned with estimating what particular equipment will cost and what will be the annual expense to maintain and operate it. One starts in the estimation of any new system by listing the principal items of equipment, such as satellites, earth stations of various sizes and functions, telemetry and tracking equipment and terrestrial interfaces, and then estimating how much each item will cost. Methods are presented for generating such estimates, based on a knowledge of the gross parameters, such as antenna size, coverage area, transmitter power and information rate. These parameters determine the system performance and it is usually possible, knowing them, to estimate the costs of the equipment rather well. Some formulae based on regression analyses are presented. Methods are then given for estimating closely related expenses, such as maintenance and operation, and then an approximate method is developed for estimating terrestrial interconnection costs.

It is pointed out that in specific cases when tariff and geographical information are available, it is usually better to work with specific data, but nonetheless it is often desirable, especially in global system estimating, to approximate these interconnect costs without recourse to individual tariffs. The procedure results in a set of costs for the purchase of equipment and its maintenance, and a schedule of payments. Some payments will be incurred during the manufacture of the satellite and before any systems operation, but many will not be incurred until the system is no longer in use, e.g. incentives. In any case, with the methods presented in the first section, one arrives at a schedule of costs and payments for all the items and the years in which they will be incurred. The second category of costing problems is one of financing or engineering economics. All the costs are first "present valued" to some reference period using rates of return appropriate to the particular situation.

One finally arrives at sets of annual costs which can be used as the basis for setting lease costs or revenue requirements and tariffs. The correspondence between methods using discounted rates of return and capital recovery formulae on one hand and those using various depreciation schedules, such as is typical of regulated industries on the other hand, is discussed.

The remainder of the paper is devoted to discussing the relationship between critical parameters, such as replacement schedules, design lifetime, satellite power and Earth station antenna size, and the overall costs.

It is shown that optima for these parameters may exist and can be calculated. In particular, the optimization of satellite replacement schedules to minimize the present value of total investment over a very long period is presented, along with simplified versions of the theory suitable for system planning.

The choice of EIRP is also discussed and a procedure for choosing the value that minimizes the costs is shown.

†Paper presented at the XXXth Congress of the International Astronautical Federation, Munich, Germany, September 1980; International Astronautical Academy Symposium on Space Economics and Benefits.

Introduction and purpose

This paper is intended to be both a didactic survey on the calculation of satellite communication systems costs and an expression of some basic ideas on optimizing systems. It is the intent of the paper to give an account at systems engineering level of the principal methods for estimating the total costs of such systems, for comparing the costs of alternatives using the method of "discounted cash flow or net present value" and using those methods to arrive at optima.

The next paragraph of the paper will describe the method in its entirety, that is, how we proceed first to estimate the actual cash outlays in the years in which they are to be made, including the effects of inflation, and then how the time value of money is considered so as to be able to make valid comparisons among different possibilities.

The third paragraph discusses the methods whereby the space segment costs are estimated, including satellites, launch vehicles and TT & C.

The fourth paragraph does the same thing for Earth stations and the fifth paragraph for the costs of terrestrial interconnect, which are often a function of satellite system choices.

The sixth paragraph constitutes the purely economic aspect of the problem and shows the methods whereby the net present value of the expenditures can be calculated. Some theoretical attention is given to this question of net present value. The calculation of revenue requirement based on such depreciation schedules is also outlined, as are methods of allowing for the effect of tax payments. The purpose of these rather elaborate estimates and financial calculations is to permit important decisions to be made early in the system planning phase when only approximate data are available on costs and schedules. The last paragraph discusses how the methods of the paper can be used to make such critical decisions as:

- (1) The tradeoff between radiated power in the satellite and figure of merit of the terrestrial receiver.
- (2) The optimum design life of the satellite system as a function of the rate of traffic growth.
- (3) The desirability of leasing transponder service versus the deployment of a dedicated satellite.
- (4) The choice between buying or leasing equipment assuming that a dedicated service is desired.

General method

The general procedure adopted starts first with identifying all the elements of cost and the years in which they are going to be incurred. Cost elements are broadly in two categories, the lease or purchase of hardware and the purchase of services, whether these services be for manpower or leased circuits. The effect of these costs is very much determined by when they are incurred. The

consideration of this "time value" of money is deferred to the sixth paragraph. The following check list shows the principal cost elements of a space communication system divided into the aforementioned hardware and service aspects and also among the space, ground and interconnect segments of the system.

	Hardware	Service
Space—Satellite	X	
Transponder		X
Launch Vehicles		X
TT & C	X	X
Ground—Earth Stations	X	X
Interconnect	X	X

We proceed by trying to identify the outlay of money in any particular year regardless of whether it is a capital outlay, a periodic payment for service or leasing facilities or an interest payment. In many cases, these costs can be determined on the basis of a published tariff such as for interconnect costs and services, or on the basis of manufacturers' quotations. Maintenance costs are sometimes estimated as a percentage of the hardware cost plus the costs of manpower. Note that a user can supply a service and element himself, in which case he has a capital and cost outlay in particular years, or he can lease the hardware and purchase the service. The numbers entered in any particular year obviously change, but the method of approach is identical. We always start by identifying each expenditure in the year in which it is made.

If a cost is to be estimated rather than taken on the basis of firm quotations, it should be estimated in the "present year" dollars and then corrected for a predicted inflation rate. If the inflation rate is i per year, then the "in year" cost C_0 is related to the current estimate C_c by eqn (1).

$$C_0 = C_c(1+i)^n \quad (1)$$

Occasionally, for purposes of official government estimating or for the pricing of items such as launch vehicles, there are official inflation rates or tables to be used along with eqn (1) or instead of it. The following is a list of inflation factors that has been used by NASA in the United States and other U.S. Government agencies in recent years for calculating U.S. launch vehicle costs. They may change.

Planning Inflation Rates (NASA Shuttle)

January 1975 (Reference)	1.0
July 1978	1.34
1979	1.45
1980	1.55
1981	1.66
1982	1.77
1983	1.90
1984	2.03
1985	2.17
1986	2.33
1987	2.49
1988	2.66
1989	2.85
1990	3.05

The most difficult part of determining the elements is that of estimating the hardware costs. This is necessary for a system planner regardless of whether he proposes to buy this hardware or to lease it from another party, since the lease costs normally depend on the hardware costs. The costs of all the hardware, whether it be spacecraft or terrestrial, are a function of the requirements, that is, the traffic to be carried. The traffic must first be predicted, its type, e.g. telephone data or television, its intensity, that is, the number of circuits, and very importantly, the rate at which it is expected to grow.

These traffic predictions are customarily put together in a matrix, one for each type of service, with the rows and columns being the sources and destinations for different kinds of traffic and the matrix elements the traffic intensities in Erlangs. The elements are estimated using conventional and sometimes not so conventional methods. The traffic intensities can be converted into numbers of circuits using the Poisson or Erlang tables (I.T.T.-6th Ed., 1975). It is often convenient to refer everything to an equivalent number of one-way telephone channels. A data channel, because of its 100% activity, is roughly the equivalent of two telephone channels, whereas a television channel, because of its great information content, is the equivalent of 1200. This equivalence is very much a function of the quality of picture desired, and its choice is beyond the scope of this paper. Given a total satellite capacity in equivalent telephone channels, one then proceeds to divide it into transponders and make link calculations using appropriate values of effective radiated power, Earth station (G/T) noise levels, intermodulation and a host of other parameters, so as to arrive at the characteristics of both the transponders and Earth stations. These characteristics are sometimes chosen to conform to existing technology or practice and sometimes optimized to minimize overall costs. In that case, the methods of this paper are used and key characteristics are varied parametrically

to arrive at design optima. One must assume a design life for the system and then estimate the satellite weight based on the number of transponders, the primary power, total propellant carried, and similar factors. The satellite weight can then be used to estimate both the satellite cost and the launch vehicle cost using either the NASA "STS" (Shuttle) or expendable launch vehicles, such as Ariane or Atlas-Centaur. The previously calculated Earth station characteristics can in turn be used to determine the interconnect costs. Figure 1 is a block diagram showing a flow diagram of the overall calculation. The outputs of the flow diagram in Fig. 1 are sets of hardware, maintenance, and interconnect service costs which can be put directly into the discounted cash flow schedule. If financing and progress payments are to be used, which is usually the case, then intermediate steps may be necessary, which will be discussed later.

All these costs are gathered and inserted in a program cost matrix (PCM) in which the rows are the various kinds of costs, such as hardware purchases, maintenance, launch services, incentive payments, insurance and interconnect services. Only cash flows are considered—not depreciation. The columns are the years (or months) in which the cash payments are made. The treatment of this cost matrix by the "discounted cash flow" or "net present value" method is discussed in Section 6.

Estimating space segment costs

Satellites

The best way to arrive at satellite costs is by a quotation from a manufacturer. This is sometimes, but not always, possible, particularly in the planning stages. If parametric studies for optimization are to be done, it is never possible. It is thus important to be able to estimate a satellite's cost from its principal characteristics.

Numerous cost models have been developed for calculating costs given weight and power estimates. Weight is a good cost driver since all the desired performance features affect S/C weight, including especially primary or radiated power.

A simple formula for guessing the on-orbit weight in kg of a satellite, given its total power in watts, is:

$$W = 7.9p^{0.64} \quad (2)$$

This equation is plotted in Fig. 2 with a number of existing satellites indicated to give an impression about the goodness of fit. In the quantum world of expendable launch vehicles, the weight is often determined by the choice of launch vehicle. For the purpose of this paper, it is assumed that weight and power estimating models are available.

One of the best and most detailed cost models ever devised was that of the U.S. Air Force several years ago (Wright, 1978). Its use requires a knowledge of the weights of the sub-systems, primary powers and a variety of other characteristics.

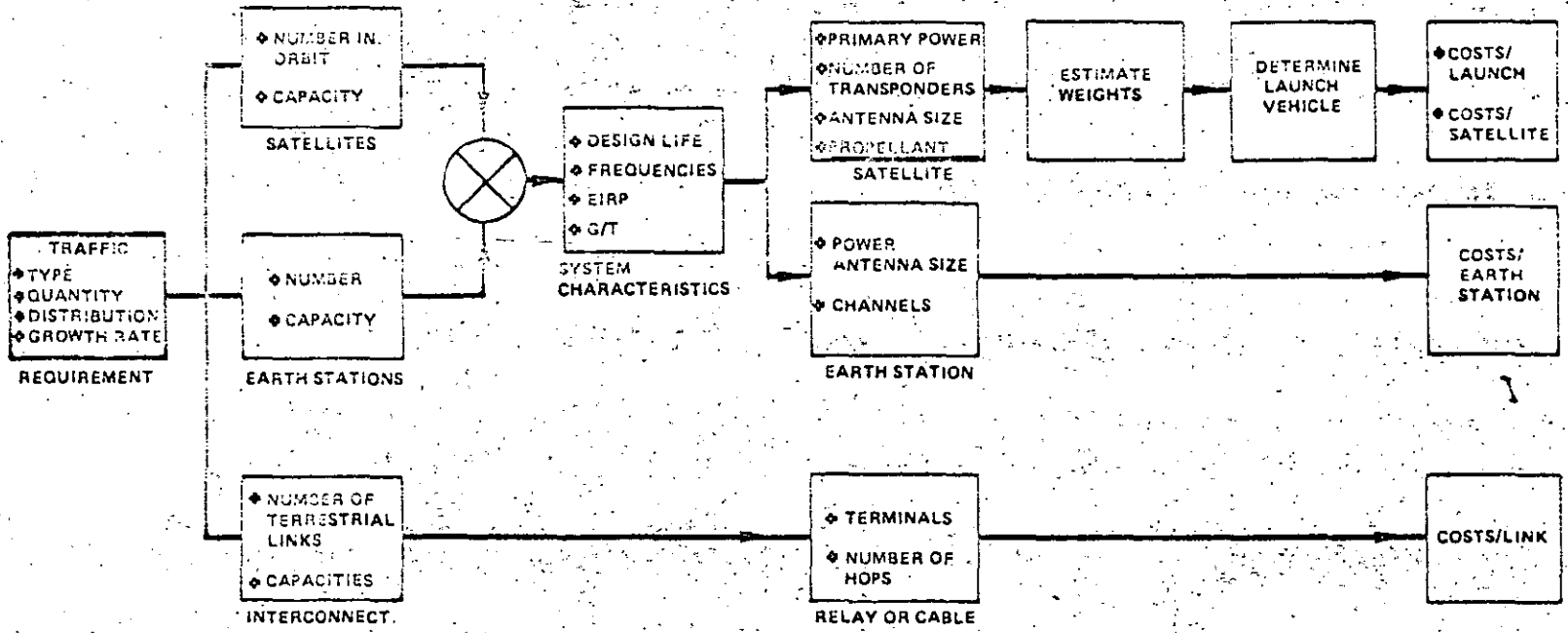


Fig. 1. Cost estimating flow diagram.

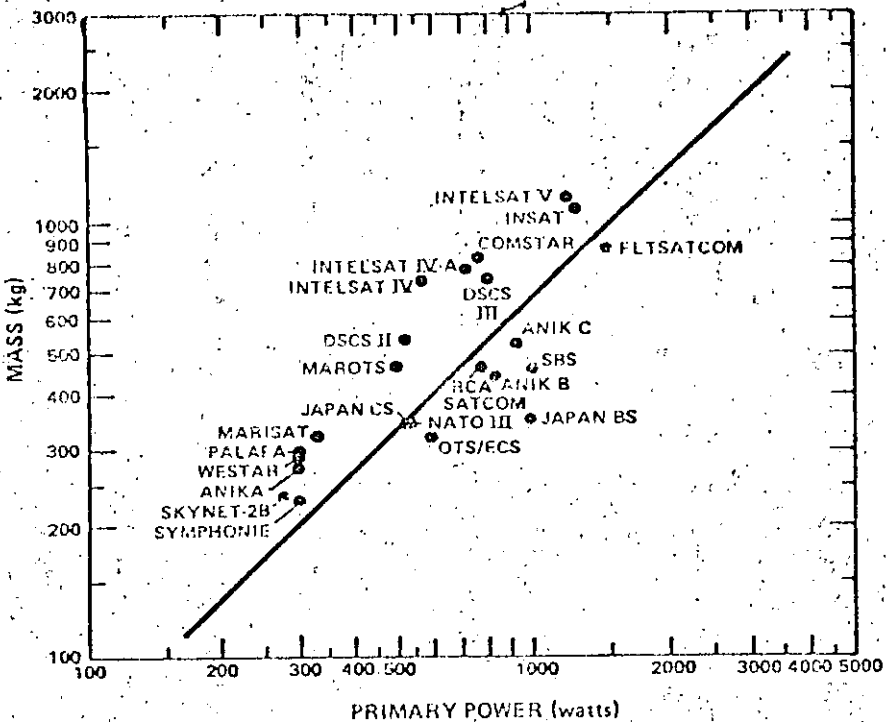


Fig. 2. Satellite on orbit mass vs primary power.

A distilled and simplified result, derivable from that model, is presented here:

$$\text{NRE} = 6035 + 50(1-u)W + 1367u^{0.51}W^{0.51}, \quad (3)$$

$$C_1 = 122 + 66.8(1-u)^{0.81}W^{0.81} + 100.5u^{0.87}W^{0.87}. \quad (4)$$

Equation 3 gives the non-recurring costs NRE of a spacecraft of total orbit mass W in kg and a fraction of this mass u devoted to the communications and antenna. C_1 is the cost of the first production unit of the same spacecraft. These costs are in 1976 dollars. These estimates yield \$55 M for NRE and \$22.7 M for the first production unit of Intelsat V--consistent enough with the contract to have been adequate for planning.

The simplified "learning curve" from which the cost of subsequent models can be estimated is that given by Wright (1936). The cumulative average cost \bar{C}_n for N units is given as:

$$\bar{C}_n = C_1 N^{-b} \quad (5)$$

If one assumes that doubling the quantities results in a reduction in unit cost to

pC_1 , then the total cost $T_n = NC_n$ is given as:

$$T_n = (C_1 N) N^{1.32 \text{ LOG } p} = NC_1 N^{3.32 \text{ LOG } p} \quad (6)$$

A frequently used and empirically justified value of p is 0.8—then:

$$T_n = C_1 N^{0.68} \quad (7)$$

This model yields the manufacturers' costs. If the satellite were purchased at the cost to the buyer, it would be augmented by an assumed profit. Many spacecraft are sold virtually at cost with the manufacturer taking a much larger profit, but in the form of incentive payments spread over the program lifetime. If so, these payments are entered in the program cost matrix to be discussed later.

Launch vehicles

The cost of launch vehicles is normally quoted by the manufacturer or agency offering launch services. It is common in today's planning to plan extra launches—say one in four or five—to allow for launch vehicle failure. An alternative is to purchase launch vehicle insurance from several companies specializing in such insurance. The next generation of launch vehicles of interest to the communications world comprises the NASA Space Transportation System Shuttle and the European Space Agency's Ariane. It is expected that both these systems will have reliabilities in excess of 90% to geostationary orbit. Nonetheless, the extra launches and spacecraft costs or insurance premiums or some combinations must be allowed for in the program cost matrix.

In the case of Shuttle launches, there are several unique features worth mentioning. NASA quotes a basic cost which includes an operations charge (18.2 M) and a use charge (4.298 M) in 1975 dollars. The operations charge is considered to inflate and just be adjusted for the appropriate year. The use charge is a recovery for installation costs and does not inflate. These figures are approximate and for non-U.S. government users. Various discounts and special prices are available and exact figures should be obtained from NASA.

If the launch is to be shared, then the fraction of the cost borne by a particular payload is given by:

$$C = \text{Total} \times \frac{4}{3} \times \frac{\text{Mass of satellite} + \text{Kick stage} + \text{ASE}}{29500 \text{ kg}}$$

or

$$C = \text{Total} \times \frac{4}{3} \times \frac{\text{Payload Length}}{18.28 \text{ m}} \quad (8)$$

The total dedicated price is multiplied by the mass or length factor, whichever is greater. Existing spacecraft designs mostly will pay by "length" but in the future it is expected that designers will learn to optimize spacecraft designs for this changing formula.

Down payments and progress payments over a 33-month anticipatory period must be made and their "time value" is important. The progress payments are entered in the PCM.

Most important of all—the Shuttle launch is into a 160 n. mi., 28.5° parking orbit. The costs of upper stage vehicles (perigee and apogee motors) to achieve the desired operational orbit must be added to the analysis. The weight and size of these added stages, along with their interface equipment, must also be considered in calculating the basic Shuttle cost.

Telemetry, tracking and command

The TT & C system usually includes at least one station for these command and control functions along with system monitoring. It may be co-located with a main communications station or completely separate. In either case, the hardware cost of these stations and their operating and maintenance costs must be included in the cost matrix.

The hardware costs are similar to those of an Earth station and are estimated in the same way. Their costs can sometimes be deferred until well after the initiation of S/C procurement. The O & M costs are principally for people to operate the station—often five teams are required for a 24 hr/day 365 day/year operation. This varies with local situations and labor practices. Equipment maintenance can be taken as a percentage of the hardware cost—10% is a conservative planning number. Normally, the operating life of a TT & C station will be much greater than the satellites, and replacement costs need only be considered over a very long planning period.

Estimating Earth station costs

The problem with estimating the Earth station costs is similar to that with estimating the space segment costs inasmuch as the most desirable method is to use cost quotations from equipment manufacturers. This is more frequently possible with Earth stations than satellites because there is a substantial amount of existing Earth station hardware, either in complete assemblies or in components, that is available and usable with many different satellite systems. In the case of satellites, particularly new systems, there is rarely any standard space hardware in manufacturers' catalogues. The unit Earth station cost is extremely important because there are so many Earth stations. The choice of optimum system characteristics is critically dependent on their characteristics. The estimation of traffic in quantity, distribution and growth, which is the very first step in the whole problem, is important in the individual Earth station costs, not only because it determines the total number of Earth stations; but also because it determines the total number of channels. In any system, there are some costs that are dependent only on the radio frequency characteristics of the Earth station, such as antennas, land, buildings, etc.; then there are other costs that are proportional to the number of satellites and stations in the network to be worked with, such as the number of uplink and downlink receiver and transmitter chains; and finally there are costs that are proportional to the number of individual information channels, such as multiplexing equipment, channel units and sometimes modems. If the plans for traffic and the number of Earth stations are

sufficiently detailed, generally the costs can be collected systematically from quoted prices and summed to get a cost per Earth station. Needless to say, in a complicated system, there may be several categories of Earth stations, each with its own unit cost. The costs for each category of Earth station, multiplied by the number involved and increased for inflation, must be put into the program cost schedule in the years in which it is expected that they will be paid for. Earth station costs in the marketplace, either on an assembled basis or by components, are very much a function of quantities bought and the extent of the competition. Intelsat Standard "A" stations have varied in cost from a few million dollars to over ten million for identical hardware, the difference being the competitive structure of the procurement and the geographical location. If, as is often the case, it is necessary to estimate the terrestrial part of a system without having detailed quotations, it is possible to proceed with simple estimating equations, such as the following:

$$\text{Cost} = K(\text{EIRP})^{0.3}$$

$$K = 4200 \text{ - No RF redundancy}$$

$$= 6500 \text{ - With RF redundancy}$$

$$= 22000 \text{ - Aircraft and ship terminals (installed)}$$

These are based on regression analyses of existing hardware costs and are better than nothing. They serve for rough estimates to begin with and, more importantly, they serve to permit the scaling of costs from one level of effective radiated power to another. The small value of the exponent reflects the significant economies of scale in the Earth station field. The elements to be considered in Earth station estimating are listed as follows:

	Normally redundant	Number required
Antenna (Incl. Drive and foundation)	No	1
High power amplifier	Yes	Per carrier (possibly)
Up converter	Yes	Per carrier
Down converter	Yes	Per carrier
Low noise amplifier	Yes	1
Modems	Yes	Per carrier
Channel units	No	Per carrier
Multiplex	No	1 Installation
Primary power (incl. "no-break")	No	1 Installation
Test equipment	No	1 Set
Buildings and facilities	No	1
Land	No	1

A notation is also made as to whether the elements are dependent on the number of channels or the total number of stations and whether they are typically redundant. Table 3 can be used as a check list to gather Earth station costs for insertion in the program cost schedule.

Estimating interconnect costs

Satellite systems for almost every commercial purpose require that they be interconnected with the terrestrial network in some form. Even maritime and aeronautical systems require such interconnection on the land side. In general, the terrestrial telephone system, television stations, data gathering points, computers and other devices must be connected to the Earth stations. Although their cost may not be part of the satellite system itself, nonetheless the cost of such interconnect systems can be substantial in either capital investment or service costs, and, more importantly, these costs can depend critically on the choice of space and Earth station parameters. They cannot be neglected in comparative and optimization studies. When the network geometry and traffic patterns are set, it is often possible to consider the interconnection as being done entirely with existing terrestrial means, and the costs can be taken from the tariffs of the carrier or PTT involved. This is a tedious but straightforward procedure. The number of points in a region to be served by a satellite system is much greater than the number of Earth stations, although in certain kinds of systems this may not be the case. Figure 3 shows the general arrangement in

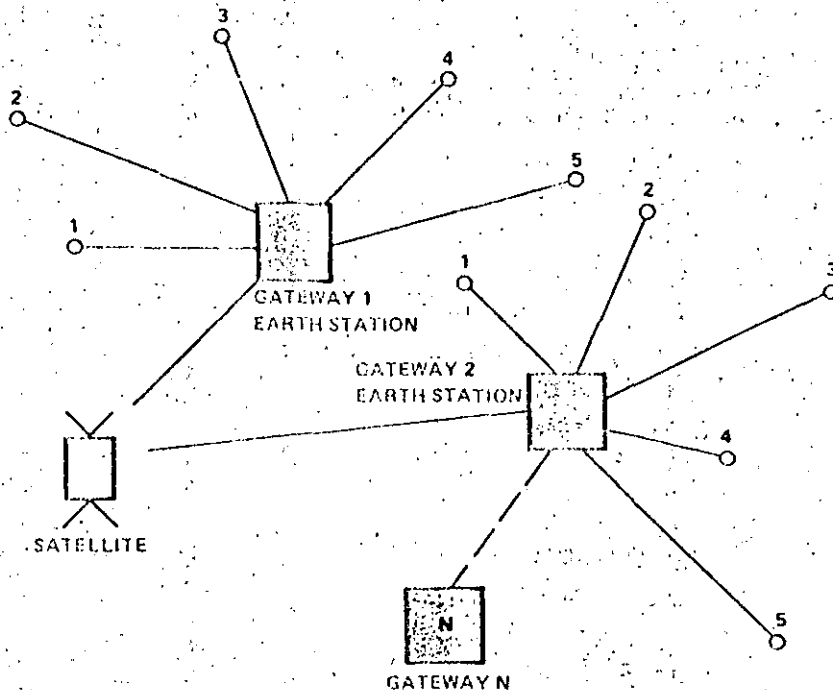


Fig. 3. Distribution network.

which we have points to be served and gateways. Interconnect costs are often quoted by carriers or PTI's on a per-mile basis, which means that the diagram must be drawn and on each link the leased costs must be multiplied by the number of channels for the appropriate distances. A general expression is shown in eqn (9).

$$C_{int} = NDnC_e \quad (9)$$

where N = no. of gateways, n = no. of points to be served by each gateway, D = mean distance from gateway to point, C_e = cost/circuit-km.

There will be some kinds of new system plans in which tariffs for interconnect services do not exist and, again, they must be estimated by rough rules that serve in the early planning phase and are often adequate for the problem of optimizing parameters. One can see that as the number of gateway Earth stations for a constant total number of points is increased, the interconnect costs will decrease and we may have a situation in which there is an optimum. The curve of Fig. 4 shows a typical result for a maritime system in which the number of gateways is substantially less than the number of points to be served, and is in particular a plot from a study of maritime system possibilities in which Inmarsat might be served by transponders on Intelsat systems and would use Intelsat stations as gateways. Note that the costs in that figure do not include the

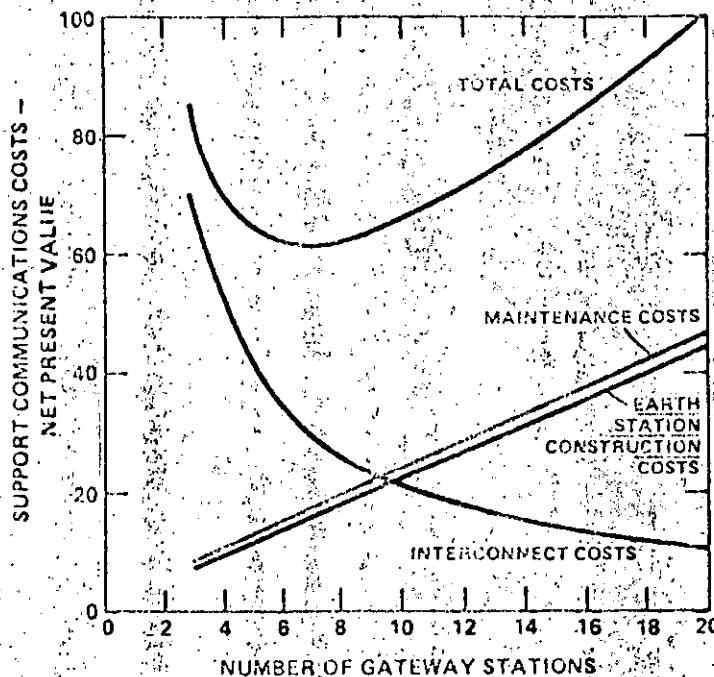


Fig. 4. Costs of maritime support communication services.

satellite; but only terrestrial elements. This kind of minimum is quite characteristic and was calculated using the simple assumptions of (9) for the interconnect costs, since, in truth, they would vary widely around the world, depending on the practices of local administrations. Nonetheless, sensitivity analyses show that this kind of study is not usually sensitive to the specific interconnect costs and that major system decisions can be based on such optimizations with some care.

Comparison methods using net present value (NPV) or discounted cash flow

Net present value

The ultimate aim of practically all economic studies for satellite systems, especially those done during the planning phase, is to identify that system that will cost the least. Regardless of how the system is to be paid for, how profitable it is desired to be, the starting point for decisions is the actual cost. Many methods have been developed and presented for comparing the costs of different choices in satellite communications systems. They are often examined in terms of cost per channel, costs per pound in orbit, ultimate revenue requirement to the operator, simple total investment costs and incremental costs for changes. Although all these methods have occasional utility, they are difficult to compare one to another, and indeed are frequently incorrect or misleading. Under no circumstances can one ignore the cost of the money itself, or as it is sometimes called, its "time value". A dollar spent today is more painful than a dollar to be spent five years from now. At 10% interest, one needs only \$0.62 today to have \$1.00 five years from now. We consider this thought to be obvious, simple, and the starting point for all the financial analyses to be done in communications systems. In the previous case, \$0.62 is called the present value of \$1.00 five years from now.

We do all our system analysis by taking the sum of the present values of all the cost elements to be incurred throughout the lifetime of the program from the first moment that money is spent until either the system is discarded or one arrives at some arbitrary planning point in the future.

For a single element, the present value at time zero is given by:

$$P_{ij} = \frac{C_{ij}}{(1+r)^j} \quad (10)$$

The net present value is found by summing over the entire matrix. If there are n years (columns) and q cost elements (rows):

$$P_0(n) = \sum_{i=1}^q \sum_{j=0}^n \frac{C_{ij}}{(1+r)^j} \quad (11)$$

For the purpose of these comparisons, we consider only cash. We use the sum of the present values of cash spent or cash received and do not consider such contrived factors as depreciation. Depreciation is an accounting device to

allocate costs and is of interest to the kinds of things that we are talking about if taxes are involved and in some way the tax rate is based on allowable depreciation. It may also have an implied effect if revenues required are calculated based on some assumed depreciation and one can assume that these revenues will be collected. In both the case of taxes and revenue, the depreciation only appears by virtue of its effect on a cash input or outgo, that is, a revenue receipt or a tax payment. We consider it erroneous to make cost comparisons for different systems where one of the costs is the equipment depreciation. Table 1 is, in a simplified and schematic form, an example of the kind of table that must be drawn up for a proposed system. We have chosen to call year 0 the year of system operation. This choice is arbitrary and the results in no way depend on this choice of origin.

It is important to remember that the elements in this table will probably be systematically varied in order to find the effects of different proposed changes

Table 1. Program cost matrix (3 satellite program)

Year	-3	-2	-1	0	1	2	3	4	5	6	7
Pay to S/C Manufacturer ^{1,4}	10	10	10	10	1	2	2	2	2	2	2
Launch Vehicle ²		5		20	20						
Launch Insurance ³				2	2						
TT & C - Purchase Stat. ⁵ O & M			5	2	2	2	2	2	2	2	2
Earth Sta. (6 Large) ⁶ O & M				5	10	10	5				
Earth Sta. (20 Small) ⁷ O & M				1	3	5	6	6	6	6	6
Terrestrial Interconnect				5	5	5	5				
"In Year" Totals	10	15	15	47	46	29	26	17	17	17	17
Present values	14.8	19.5	17.1	47	40.4	22.3	1.6	0.7	8.8	7.7	6.79
NPV (at 15%)				212.1							
Level Cost					4.95	49.5	49.5	49.5	49.5	49.5	49.5

NOTES FOR TABLE 1

1. Payment to contractor of 40M in 4 equal payments before launch.
2. 2 Satellites in orbit - one unlaunched spare.
3. Launch Insurance at 2M/launch for both vehicle and spacecraft.
4. Incentives at 1M/yr. per spacecraft - successful operation after launch.
5. TT & C Sta. - 5M and 2M/yr. operating and maintenance.
6. 6 Large Earth Sta. - 5M and 1M/yr./sta. O & M (incl. microwave relays to central office).
7. 20 Small Earth Sta. 1M and .2M/yr./sta. O & M.
8. 26 Microwave relay installations for terrestrial interconnect - 5M/piece + .050M/yr.) O&M - included in E/S estimates.

and to optimize such parameters as the number of gateways, satellite design life and satellite effective radiated power. After the table is prepared, eqn (11) is applied to the program cost matrix. In a real case, the whole exercise can be extremely complicated, and it is generally necessary to program it at least on a desk calculator, and frequently on a computer. In putting cost elements into the PCM in future years, it is wise to allow for the inflation or hardware costs as mentioned in the second paragraph, and also for the possible growth in leased service costs. In planning systems to work with Intelsat or other existing systems, it is frequently desirable to predict a reduction in space segment costs. Intelsat space segment costs have been reduced by a factor of 10 during Intelsat's lifetime if allowance is made for inflation in the same period. This is a spectacular reduction, and obviously cannot be ignored. A particularly good analysis of the Intelsat system is given by Early *et al.* (1976).

We often find in preparing program costs matrices that there are cost elements repeated each year or cost elements that are increasing or decreasing linearly. Considerable computation time can be saved by calculating these things separately in accordance with several classical equations from financial analysis which are presented here. The initial present value P_0 of a uniform series of " n " payments of A at a discount rate " r ":

$$P_0 = \frac{A(1+r)^n - 1}{r(1+r)^n} \quad (12)$$

The future value of the same series of payments at the end of the current period in question, sometimes called a "sinking fund", is given by:

$$P_n = \frac{A}{r} [(1+r)^n - 1] \quad (13)$$

If, instead of a constant payment A , there is a linear increase starting from zero, each period equal to $G(n-1)$ is called a "gradient" and the present value of a gradient is given as:

$$P_0(n) = \frac{G}{r} \left[\frac{(1+r)^n - 1}{(1+r)^n} - n \right] \quad (14)$$

All these equations are derivable from a single assumption. There are also several theorems about net present value which are useful in reasoning and which underlie many of the methods. These theorems are quoted here without proof but are easily established.

If two systems have equal net present values, at some point in time the net present values are equal everywhere in time. Thus, comparisons can be made at any convenient point.

The net present value for a matrix of costs is independent of whether the rows or columns are calculated first. The total in each year or column can be present valued to year zero and these partial net present values summed, or each

cost element or row can be present valued and these partial net present values summed.

Both these theorems are based on the use of the same discount rate throughout the entire computation. We consider this to be the correct method for doing this kind of calculation. The point is occasionally made that industrial organizations should use the desired return on equity for money that they have to invest; for money they have to borrow they should use the discount rate; for money that they have available and do not spend (but keep in the bank) they should use a lower interest rate. Mixing the rates in this fashion can be dangerous even if done correctly and often can be erroneous. At best, it is deceiving. In our opinion, a net present value analysis or "discounted cash flow", as it is sometimes called, should always be done at a single rate, which is the rate that the entity in question considers desirable or historically justified for return on its invested capital. If money must be borrowed, then the receipt of the borrowed sum itself is simply an input to the PCM and the payments of interest and amortization on this borrowed sum are also cash outflows entered in the appropriate years in the PCM. The same is true for money which the entity may find necessary to leave invested in a savings bank or bonds during the program period. This money is simply entered into the PCM only as cash in or out and separate entries are made to allow for the interest paid to or received from banks. The PCM elements are always cash and a single discount rate for the desired return on invested capital is used to evaluate the net present values.

Depreciation and taxes

In order to complete the PCM, it is occasionally necessary to consider the effect of taxes. These methods are particularly suitable for lease vs buy decisions, either on the part of government or private entities (SACOM, Pritchard, Throop & Waylan). In many countries where the satellite system is operated as a commercial venture, income taxes will be paid to the government based on profitability, and often tax credits will be allowed, based on investment. If the government itself is doing the analysis, for instance to compare the costs of leasing the buying services, it is frequently desirable to consider the effects of receipt of taxes from the sub-entities involved in the system, that is, equipment manufacturers, system operators and even financial institutions. If taxes are to be considered, then clearly the tax structure of the country involved is the starting point, and no general procedure can be given. If we are dealing with the United States, which is typical of countries in which communication is done by commercial entities but regulated in the public interest, then the method is easily outlined, and is probably typical of regulated industries in similar countries. The revenue that a utility is permitted is given by equation:

$$R = Q_i + M + RI + T$$

$$T = (R - Q_i - M - iD)t \quad (15)$$

where M = operating costs, D = debt, Q_i = depreciation in the i th year, I =

investment unamortized, T = taxes, r = permitted rate of return on investment, t = tax rate, i = interest rate on debt.

Note that the return is based on the unamortized investment and not on the total volume of sales, which is more typical of manufacturing organizations, and that the return is also allowed to include taxes on an additive basis. Now one must prepare a depreciation schedule in order to set the revenue requirements on a year-by-year basis and also in order to make allowance for taxes. The depreciation schedule chosen is again a matter of both accounting convenience and sometimes regulation. Occasionally, the cash requirements for revenue are levelled; that is, although the revenue requirement will diminish in each year, eqn (12) is used to calculate an equivalent constant revenue requirement A over the lifetime of the system. It is important to note, and easily proved, that the net present value of these cash returns is independent of this choice, and even more interestingly, is independent at the rate at which the equipment is depreciated, or even if it is depreciated at all. Once again, we would like to emphasize that the need to calculate revenue requirements, either changing or levelled, and taxes, is only to estimate the cash flow. In the comparison study of the costs of different options the revenues, if they are set by regulation, require a depreciation calculation, and taxes, if they are to be paid, also require such a calculation. There exist many examples of overall system planning in which neither of these considerations is appropriate. The planning of a complete system to be owned and operated by a government and to be purchased abroad so that there are no tax considerations can be done with complete detail and reliability without any consideration of depreciation schedules. Do not confuse depreciation with deterioration. Depreciation is an accounting device to allocate costs and is only loosely connected with the deterioration of the hardware. It is clearly necessary to consider the lifetime of the hardware, how often it will be necessary to replace it, and how much it will cost at that time.

Optimization studies

Design lifetime

One of the principal reasons for developing the methods in the previous paragraphs is to permit certain kinds of optimization studies that, if done correctly, can permit savings of many millions in costs of satellite systems. Two in particular are worth mentioning, although there are many others that can be considered in an elaborate system. They are the optimization of design lifetime of the satellite and the optimization of its effective radiated power. If one assumes that the traffic in a system, whether it be telephone, television or data traffic, is going to grow by some percentage each year, i.e. in accordance with a compound interest formula, then the design of the satellite must be for a capacity which is greater than its initial capacity to allow for this traffic growth. For example, if a satellite is going to be designed for a seven year life, and if one assumes a growth of 10% per year, then it has to be designed for a capacity equal to twice its initial requirement. This is clearly costly, and must be traded off against the possibility of designing a smaller satellite that has to be replaced more frequently. The basic trade-off is shown pictorially in Fig. 5.

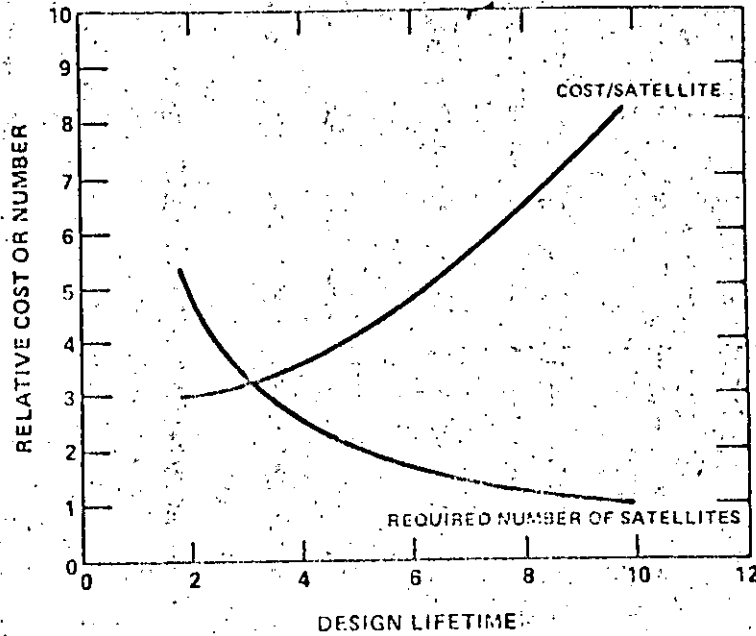


Fig. 5. Cost/satellite and required number vs design lifetime.

The problem can be modeled in principal mathematically, and some very elegant studies have been made (Snow, 1975). A simple and practical approach is possible (Pritchard, 1979) and it is not difficult to show that there is an optimum lifetime satellite n_0 given by eqn (18) and plotted in Fig. 6.

If one assumes the cost of a spacecraft depends on three terms, one constant, one proportional to traffic T and one to the lifetime n :

$$C = C_0 + aT^k + bn \quad (16)$$

and

$$T = T_0(1+r)^n \quad (17)$$

the cost per year C/n can be written and routinely differentiated, set equal to zero, to derive an optimum lifetime n_0 .

$$n_0 = \frac{1}{k \log(1+r)} \quad (18)$$

K is a factor dependent on the technology and likely to range between 0.8 and 1.25.

Although this mathematical modeling serves to demonstrate the idea in any particular case, it is preferable to do a detailed cost analysis using the methods outlined in the previous sections, rather than to use the approximate closed form solution of eqn (18).

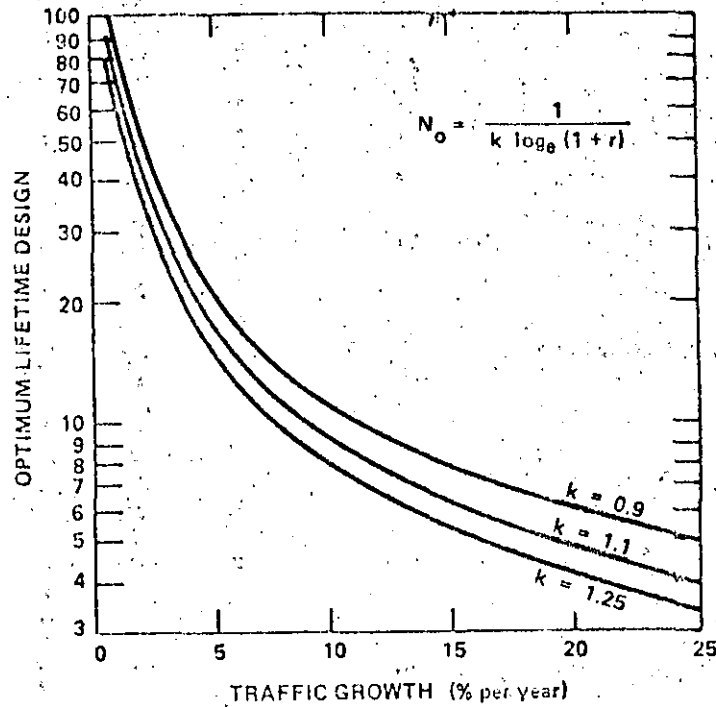


Fig. 6. Optimum design life vs traffic growth.

Radiated power

Another typical and perhaps even more important optimization problem is that of choosing the best value of effective radiated power. This is essentially a trade-off between satellite and Earth station characteristics. It is not difficult to show, using the communications link equation, that the following equation holds for (C/N_0) the carrier-to-noise density and the measure of information transmitting capabilities.

$$A_c \left(\frac{C}{N_0} \right) = k D_E^2 \left(\frac{P_t}{T_r} \right) \quad (19)$$

where A_c = ground area to be covered, P_t = transmitter power (or either end of link), T_r = receiver system temperature, D_E = Earth station antenna diameter, k = constant.

This equation is good for either the uplink or downlink and is basic to the economics of system trade-offs. On the downlink, one trades Earth station antenna size against satellite transmitter power and in the uplink, one trades either an Earth station transmitter size or transmitter power against satellite receiver temperatures. The simplest approach is to write the total system capital cost as:

$$C = C_t + N C_E \quad (20)$$

we assume

$$C = k_s P^{a_1} + N k_E P^{-a_2} \tag{21}$$

then

$$P_{opt} = \left(\frac{N k_E a_2}{k_s a_1} \right)^{1/(a_1 + a_2)} \tag{22}$$

$$C = N \left(\frac{k_E}{k_s} \right)^{3/2} \tag{23}$$

where N = number of Earth stations, C_s = space segment cost, C_E = cost of a single Earth station, k 's and q 's are constants depending on technology.

We assume that there is only one kind of Earth station, whose costs are algebraically related to the antenna area and thus inversely to the transmitter power in the satellite, and the costs of the spacecraft are directly related to its transmitter power. The optimum value is again found by differentiation and equating to zero. This trade-off is shown schematically in Fig. 7.

Note that we speak here of transmitter power of a satellite rather than its effective radiated power. This is usually the more fundamental consideration, since effective radiated power includes the consideration of the satellite antenna

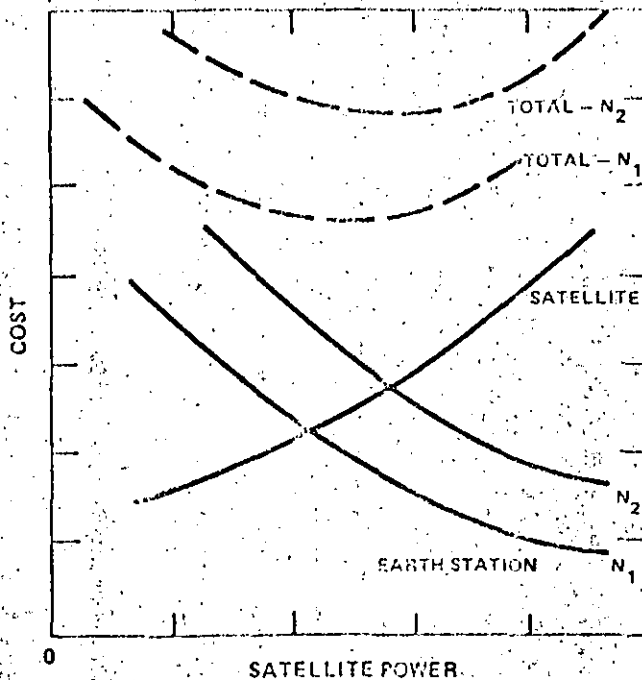


Fig. 7. System cost vs satellite transmission power with number of Earth stations as parameter.

gain and it in turn is determined by the area on the ground to be covered, but typically is not a parameter over which the system designer has any freedom, except by the use of multiple spot beams. In that case, the thoughts don't change, just the details. There is clearly an optimum satellite power, as seen on the curves in Fig. 7, and these optima are arrived at in a specific case by estimating the hardware costs and doing the discounted cash flow analysis of the previous sections. In some cases, such analyses can be simplified by looking at capital investment costs only and assuming that all the expenses are incurred initially. We consider this to be a simplification that can lead to error. There are huge numbers of Earth stations involved. The procurement and operating lifetime for the Earth station can be very long and the present value of all the Earth station investments and the maintenance costs of the already built Earth stations, etc., should be considered in their proper time periods in order to arrive at the correct conclusion.

References

- American Telephone & Telegraph Co. (1977) *Engineering Economy*, 3rd Edn McGraw-Hill, New York.
- Early L. B. et al. (1976) Economics of Communications Satellite Systems--1976. *Acta Astronautica* 5, 261-273.
- Grant E. L. et al. (1976) *Principles of Engineering Economy*, 6th Edn Wiley, New York.
- Howard W. Sams & Co., Inc. (1975) *Reference Data for Radio Engineers*, III 6th Edn.
- Pritchard W. L. (1979) Some Economic Aspects of Domestic Satellite Systems in the 1980's, 19mo *Convegno Internazionale Scientifico sullo Spazio*, Rome, Mar. 1979.
- Pritchard W. L., et al. (1978) SACOM, a Satellite Cost Model, presented at *EASCON '78*, Washington, Sept. 1978.
- SAMSO/ACC Los Angeles (1978) *SAMSO Unmanned Spacecraft Cost Model*, 4th Edn.
- Snow M. (1975) Investment cost minimization for communications satellite capacity--refinement and application of the Cheney-Manne-Srinivasan model. *Bell J. Econ.*, Autumn 1975.
- Wright T. P. (1936) Factors affecting the cost of airplanes. *J. Aeronaut. Sci.* 3, 122-128.

DOMESTIC SATELLITE COMMUNICATIONS IN LATIN AMERICA

Elio Sion
Space and Communications Group
Hughes Aircraft Company
El Segundo, CA 90009

Ever since the era of satellite communications began, Latin America has been one of the most active regions in the world in implementing domestic satellite systems. The many domestic systems in operation today in Latin America attest to this observation.

By the early 1970's, most Latin American countries either had installed an Intelsat station or had access to one. The transition to the new technology at times created paradoxes. Many will remember when in that part of the world it was faster to call New York or London than a city 20 or 30 kilometers away. Even today, in most large countries some isolated regions are difficult or impossible to reach because a communications system has not yet been installed there.

This paradox was very effective in demonstrating the "instant" benefits of satellite communications. Administrations seeing the slow development of communications via terrestrial means in their countries quickly took the first step toward national domestic satellite systems.

The logical and economical way was to grow into a national system by first leasing transponder capacity on an Intelsat satellite. And this was precisely the approach taken, with Brazil leading the way in 1974.

As a preliminary to a national system, the use of leased Intelsat transponder capacity has numerous advantages for nations preparing to implement a national domestic system of their own.

For cash-limited nations, the initial investment is relatively small because it involves only the purchase of a few earth stations and the appropriate lease of transponder capacity at \$0.8 million per year (in U.S. dollars) for preemptible global beam transponder service. Consequently, an administration need not concern itself at the outset with the costs (satellites, TT&C stations, training and staffing of personnel) and the efforts associated with a space segment. Instead, it can devote its energies to building earth stations and integrating them into the terrestrial network.

A disadvantage of leased Intelsat service is that, in general, Intelsat satellite power levels are significantly lower than those achieved with a domestic system. Consequently, domestic earth station antennas sized for Intelsat power levels are considerably larger and therefore more expensive than those used for national domestic systems. And, those earth stations destined for rural communications become oversized when the administration buys its own national satellite.

However, the flexibility and the low initial cash requirements of a domestic system based on IN-TELSAT leases well offset the cost of overbuilt and overpriced earth stations procured in the initial stages of system buildup—provided the transition to an optimized national domestic system does not lag too far behind. For example, Brazil, which initiated service in 1974, now has a complement of 65 (10 m) earth stations, with 18 more planned for installation by the time that its domestic satellite, SBTS (Sistema Brasileiro de Telecomunicações por Satélite), is launched in February 1985. These additional 18 stations sized for the more powerful national domestic satellite, SBTS, use only 6 m antennas. Eventually the Brazilian earth complement is to include several thousand of these smaller earth stations. In this overall perspective, the initial overexpenditure for larger, 10 m earth stations has only a small impact on the total cost.

However, there are some factors to weigh in considering INTELSAT leases: 1) the desired transponder capacity may not always be available for lease when needed; 2) the low transponder lease cost of \$U.S. 0.8 million per year is for a preemptible transponder. Therefore, any time INTELSAT needs the transponder for guaranteed (backup) services, the leased service can be interrupted (although preemption has not been required to date). 3) Growth or extra leased transponder capacity at equally low lease costs cannot be guaranteed.

Figure 1, which compares the size of the first Intelsat satellite with that of the current Intelsat VI being built by Hughes, graphically illustrates the large growth that has taken place in the communications capacity of satellites.

Table 1 shows the status of domestic satellite systems in Latin America. A description of the various Latin American domestic systems follows.

TABLE 1. DOMESTIC SATELLITE SYSTEMS IN LATIN AMERICA (as of June 1983)

Country	Earth Stations Installed		Planned Earth Station Installations By End of 1985	Intelsat Transponder Leases	Services Provided	National Domestic Satellite
	Transmit-Receive	Receive Only				
Argentina	1 (13 m) 30 (11 m) 2 (11 m) mobile 3 (6.1 m) transportable		3 (11 m)	1 1/2 Global ⁽⁴⁾	Telephony/ DAMA 1 TV 1 Radio	International tender for satellites in preparation
Brazil	1 (15 m) 20 (10 m)	44 (10 m)	18 (6 m)	6 Hemispheric ⁽¹⁾ 1 Global	Telephony + 2 TV	2 Hughes type HS 376 24 channel C band under construction by Spar of Canada 2 Ariane launches 1985
Chile	3 (11 m)		3 (11 m)	1/2 Global ⁽⁵⁾	Telephony	
Colombia	3 (13 m) 14 (11 m)		5 (7.5 m) 2 (13 m)	1/2 Global ⁽⁴⁾ 1/2 Hemispheric	Telephony + TV	SATCOL satellite project under study
Mexico	7 (11 m) 2 mobiles	12 (11 m) 23 (7.5 m) 113 (7.0 m) 14 (5 m) 5 (4.5 m) 2 transportable	24 (7.5 m) 86 (7 m)	3 Spot ⁽²⁾ 1 Westar/Galaxy ⁽³⁾	4 TV + Telephony	2 type HS 376 under construction by Hughes 18 channels at C band 4 channels at K band 2 STS launches 1985
Peru	3 (11 m)	3 (6 m)		1 1/4 Hemispheric ⁽⁴⁾	Telephony + TV	
Venezuela	1 (11 m)	1 (9 m) 2 (7 m)	21 (7 m)	1 Hemispheric ⁽⁴⁾	1 TV	

(1) Intelsat IV-A, F-2, built by Hughes and launched January 1976. See Figure 2 for a photograph of Intelsat IV-A.

(2) Intelsat IV, F-1, built by Hughes and launched May 1975.

(3) Western Union's Westar 4, HS 376, built by Hughes and launched February 1982.

Galaxy 1, Hughes Communications-operated HS 376, built by Hughes and launched June 1983.

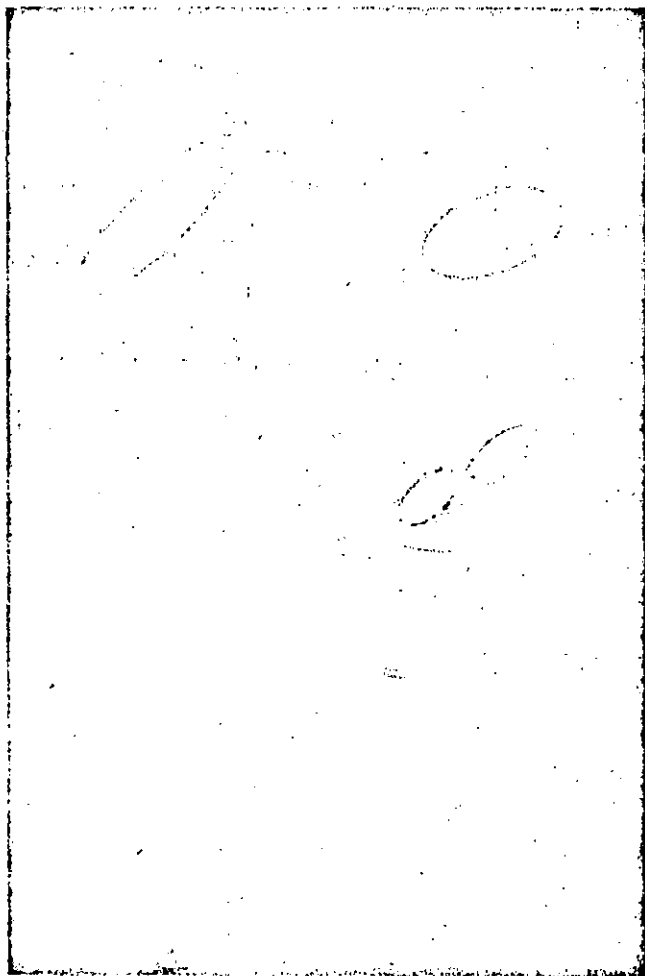
(4) Intelsat V, F-4, built by FACC and launched March 1982.

(5) Intelsat IV-A, F-1, built by Hughes and launched September 1975.

BRAZIL

Brazil was the first Latin American country to establish a domestic satellite system. In July 1974, coverage of the World Cup games was transmitted from Tangua to Manaus and Cuiaba via a leased Intelsat transponder. Brazil is also the first Latin American country to have procured its own national domestic satellite: a Hughes type HS 376 satellite from Spar Aerospace of Canada. Two satellites are scheduled for launch in February 1985 and August/September 1985 respectively.

FIGURE 1. THE FIRST INTELSAT SATELLITE



The first Intelsat communications satellite is shown in front of a life-size painting of its latest satellite descendant, Intelsat VI. While the first Intelsat satellite carried only 240 telephone calls in the mid-60s, the new Intelsat VI satellite will begin carrying 33,000 telephone calls in 1986. Both satellites are projects of Hughes Aircraft Company in El Segundo, California.

Today Brazil has a domestic satellite terrestrial network consisting of one master station (15 m), 20 transmit-receive (10 m) stations, and 37 TV receive-only stations. The 21 station transmit-receive network is operated by Embratel (Empresa Brasileira de Telecomunicações) and provides telephony as well as TV distribution. More than a third of these stations are located along the Amazon River and its tributaries.

FIGURE 2. INTELSAT IV-A SATELLITE



The first of six Intelsat IV-A telecommunications satellites is shown being prepared for launch by Hughes Aircraft Company engineers. This satellite was launched in September 1975, and the last Intelsat IV-A was launched in March 1978. The Intelsat IV-As, with a spot-beam antenna design, provide twice the channel capacity of their predecessors, the Intelsat IVs. The Intelsat IVs and IV-As form a global satellite system. Hughes built these spacecraft for the International Telecommunications Satellite Organization.

Two TV networks, Globo and Bandeirantes, using some 44 TV receive-only earth stations, distribute television to the cities in which they are located. The transmitters for these TV networks operate through Embratel's earth stations in Rio de Janeiro and Sao Paulo. By the end of 1985, or before Brazil's new national domestic satellite is to be launched, 18 more transmit-receive earth stations are to be installed by Embratel.

Brazil's domestic satellite, SBTS (Sistema Brasileiro de Telecomunicações por Satélite), is presently under construction. The satellite is a 24 channel, C band, Hughes HS 376 type of satellite being built by Spar of Canada under license to Hughes. (See Table 2 for the satellite's characteristics and Figure 3 for its coverage pattern.) Hughes is also participating in the construction as a subcontractor to Spar. A TT&C station to operate the SBTS satellites is also under construction in Guaratiba near Rio de Janeiro.

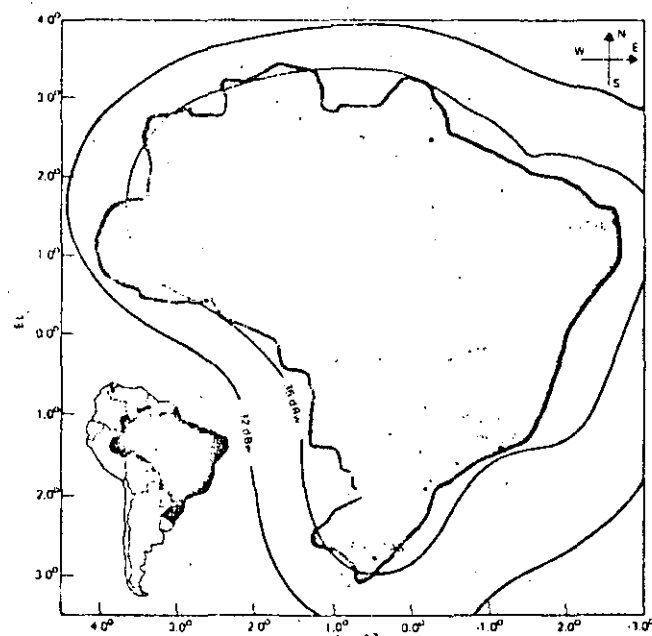
For the past six years, Avibras, a Brazilian company, has built the antennas for the earth stations. Embratel has built the earth stations in Brazil, importing only certain subsystems, such

as transmitters, LNAs, and other components built by Hughes and other suppliers.

TABLE 2. BRAZILIAN SATELLITE CHARACTERISTICS

Characteristic	Name or Value
Transponders	24 at 36 MHz (+ 6 spares) 10 W power 4/6 GHz
Type of spacecraft and manufacturer	Hughes HS 376, Spar (2 spacecraft program)
Design life (fuel-dependent)	8 years
Launch vehicle	Ariane
Launch dates	February 1985, August 1985
Orbital locations	60°W to 70°W
Operator	Embratel (Empresa Brasileira de Telecomunicações)

FIGURE 3. BRAZILIAN SATELLITE C BAND COVERAGE



MEXICO

Mexico's domestic satellite system is the most extensive in Latin America and ranks among the largest in the world. Service was inaugurated via leased Intelsat transponders on May 1, 1980. Morelos, Mexico's new domestic satellite system, is named after Jose Maria de Morelos y Pavon, "Servant of the People and one of the Liberators of Mexico." Two Morelos satellites are being constructed by Hughes in El Segundo, California. Morelos is a Hughes HS 376 hybrid (C and K band) satellite, which will be launched on the shuttle in May and September 1985. (See Figures 4 through 6.) A TT&C station is also being built by Hughes in Mexico City.

Today, Mexico's terrestrial network includes 174 earth stations. Two of these are trailer-mounted mobiles, and two are transportable earth stations. In addition to the two mobiles, seven of the total installed earth stations are transmit stations: four in Mexico City, one in Tijuana, one in Cancun,

and one in Tulancingo. All others are TV receive-only stations, which, however, have been designed for easy conversion into transmit-receive stations to provide telephony services.

The first "private" domestic satellite telephony link is to be established in October 1983 when Petroleos Mexicanos (PEMEX) inaugurates its 24 channel satellite telephony link between Ciudad del Carmen and Mexico City. PEMEX plans to expand its telephony network beyond this initial link as soon as earth stations can be installed on some of the oil platforms.

Presently, Mexico is leasing from INTELSAT three spot beam transponders (at 32.7 dBW at the country's edge) on the Intelsat IV F-1 built by Hughes and launched in May 1975. Although this satellite has exceeded its 7 year design life (which is fuel-dependent), Mexico expects to use it until May 1985, when the first Morelos domestic satellite will be launched. This confidence is based on the extended lifetime of Intelsat IV F-7, which the present Intelsat IV F-1 satellite replaced. Intelsat IV F-7 had exhibited a useful life in excess of 10½ years when it was retired because it ran out of fuel.

The three leased transponders provide TV distribution of four TV programs. In addition, half the capacity of a transponder is used by PEMEX for SCPC telephony. A government TV channel occupies one transponder, and another transponder is used to distribute two commercial TV programs (Televisa). Another half transponder is used to distribute a San Diego-originated U.S. television program picked off the air and transmitted from Tijuana to Mexico City for use by CABLEvision for CATV distribution.

In addition to Intelsat, Mexico also leases a transponder on the Galaxy satellite to transmit live Mexican programs to the U.S. for distribution by Spanish International Network (SIN). Galaxy 1 (as well as Westar 4, which it replaced) is a Hughes HS 376 satellite operated by Hughes Communications, Inc.

FIGURE 4. MEXICO'S MORELOS, AN HS 376 SATELLITE



With the accelerating pace of earth station installations, Mexico estimates that by mid-1984 it will need to lease an additional Intelsat transponder.

The Morelos satellite is Hughes' first hybrid HS 376 satellite. The C band wide channels are intended for digital trunk telephony, while the narrow band channels are to be used for analog telephony and TV. K band is to be used for rural telephony and TV, data, and private line networks. Mexico is targeting some social areas for particular attention: educational television, health and family planning, and agricultural education. The social benefits of these efforts will be felt increasingly as the number of installed earth stations increases. Some 10 years into the future, the Morelos earth segment is slated to include approximately 10,000 earth stations—an ambitious but realizable goal, given Mexico's determination and drive to get the job done. The Morelos satellite system is on its way to becoming the new servant and liberator of Mexico.

FIGURE 5. MORELOS C BAND COVERAGE,
WIDEBAND CHANNELS (72 MHz, 10.5 W)

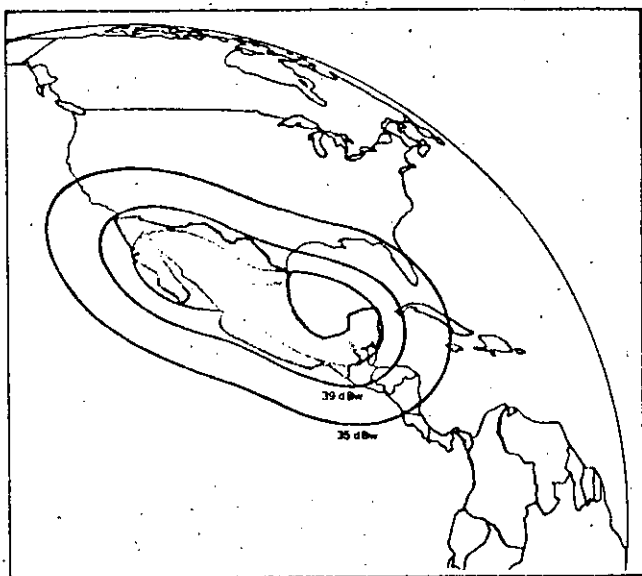


TABLE 3. MORELOS SATELLITE CHARACTERISTICS

Characteristic	Value, Name, or Date
Transponders	
C band, 4/6 GHz	12 at 36 MHz at 7 W (+2 spares) 6 at 72 MHz at 10.5 W (+2 spares)
Ku band, 14/12 GHz	4 at 108 MHz at 20 W (+2 spares)
Design life (fuel-dependent)	9 years
Launch vehicle	STS/PAM
Construction contract initiation date	October 1982
Launch dates	May 1985, September 1985
Orbital locations	113.5°W and 116.5°W
Operator	Secretaria de Comunicaciones y Transportes

ARGENTINA

Domestic systems operation via leased Intelsat transponders was inaugurated in Argentina in April 1982. Today there are 31 earth stations using 11 m antennas and the 13 m master station in Balcarce. In addition, there are two mobile (trailer-mounted, 11 m) stations and three easily transportable (6.1 m) stations. All the stations have transmit-receive telephony capability and a channel complement ranging from 5 to 64 telephony circuits. Interconnectivity between stations is to be achieved through a DAMA network. Two submaster stations in the north and south of the country can be used to back up the master in Balcarce.

Three more 11 m stations are being built for installation in the near future. The services provided by the Argentinian domestic satellite network include telephony plus one TV channel and one radio channel. The TV and radio programs received by the earth stations are rebroadcast by local transmitters operating in the standard broadcast bands.

These services are provided by leasing one and a half global beam transponders in spare capacity on an Intelsat IV-A, F-4. This satellite, built by Hughes and launched in May 1977, is presently operating satisfactorily beyond the guaranteed 7 year life.

Recently, the Argentinian government decreed that an international tender be readied by 30 December 1983 for the purchase of a multipurpose national domestic satellite system. According to this timetable, Argentina could by 1986 or 1987 operate its own satellites with a much expanded terrestrial network.

COLOMBIA

Domestic satellite service was initiated in Colombia in June 1982 with three Standard B (13 m) earth stations and the lease of half an Intelsat

global beam transponder. Since then, 14 more earth stations (7.5 m) were installed, and in July 1982, an additional half of an Intelsat hemispheric transponder was leased. Five more earth stations will be added to the network within the next two years, two of them in 1984. At present, the services offered are 1 channel TV and telephony, with the stations having a telephony circuit complement of 12, 24, 60, and 120 circuits.

A tender for two SATCOL satellites was cancelled in September 1982. ENTEL and other government agencies are now conducting studies to reassess the requirements for a domestic satellite system in the context of a new telecommunications plan.

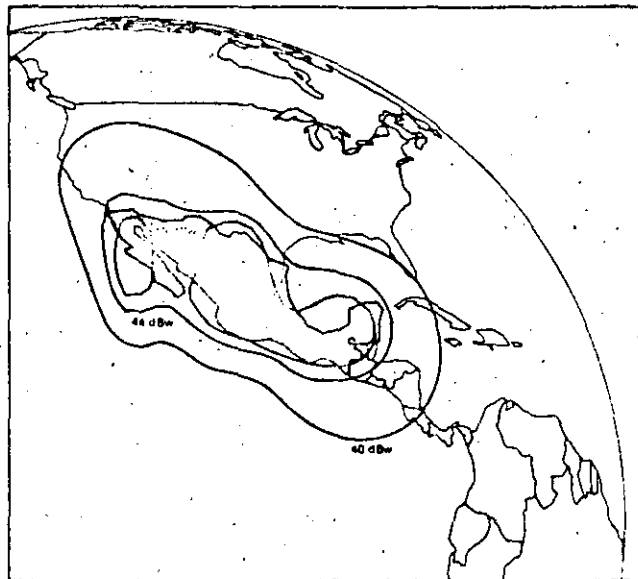
By the time SATCOL is launched, or even before, an additional 150 light traffic stations (4.5 m) will be installed in the first phase of a massive effort to establish a versatile domestic network. Initially, they will be for TV reception and a few circuits of telephony. The service requirements for this network include: rural telephony, entertainment TV, and educational TV. In the second phase of the terrestrial network buildup, the planners foresee the installation of several thousand earth stations to provide every town and village with adequate telecommunications services.

VENEZUELA

Domestic satellite service began in Venezuela with the lease of one Intelsat V transponder in September 1982. At present, the earth segment consists of an 11 m transmitter in Cantaura and two TV receive-only stations—a 9 m nodal station in San Fernando, Apure and a 7 m station in Puerto Ayacucho. A third, 7 m earth station is to be installed this year in Sta. Elena de Uairen.

The TV programming being distributed is that of one of the two government networks, and it includes commercials. In the near future, an addi-

FIGURE 6. MORELOS K BAND
COVERAGE (108 MHz, 20 W)



tional 21 TV receive-only earth stations will be installed, bringing the total to 24. Venezuela's CANTV is considering leasing a second transponder to add telephony and telex to its satellite services. For the time being, the purchase of a satellite system is not being considered.

CHILE AND PERU

Chile now has two Standard B (11 m) stations and one 18.2 m master station in Santiago. These stations provide telephony service between Santiago, Punta Arenas and Coihaique by leased use of half an Intelsat IV-A global beam transponder.

The Peruvian domestic system consists of earth stations in three towns in the eastern jungle of San Martin: Juanjui, Tocache and Saposá. Telephony services are provided from three towns to the rest of Peru. Four other villages are connected via UHF/VHF radio telephones. The lease of 1/4 Intelsat hemispheric beam transponders also provides for TV distribution to the stations. Three additional 6 m TV receive-only stations are planned.

SUMMARY

The picture that emerges from this short "status report" is of a vigorous, determined effort by Latin American countries to expand their telecommunications by satellite. Sixteen and a quarter leased transponders are being used by the seven nations mentioned. Two national satellite systems, Brazil's and Mexico's, are currently under construction.

The use of leased transponders for internal communications is growing by leaps and bounds. In developing a domestic network, each country has established different priorities. In Mexico, the initial impetus has been to distribute four TV

channels to its 200 earth stations. In Brazil, the effort has been to bring telephony to Amazonia and the Mato Grosso first, and then to let private companies add TV distribution. The record so far indicates that a domestic satellite system using leased transponders is highly beneficial to internal communications, because two out of the seven nations are already procuring their own satellites and another two are seriously considering doing so soon.

Satellite communications growth for internal use will easily exceed 20 to 25 percent per year within the next few years—a good indicator of healthy economic growth in Latin America.

Trends in Satellite Communications

1027

Albert D. Wheelon

President
Space and Communications Group
Hughes Aircraft Company
Los Angeles, California
United States

INTRODUCTION

The 4 years since the last Telecom Conference have seen dramatic changes in telecommunications. These are nowhere more apparent than in the communications satellite sector. The sudden change from a regulated monopoly to a competitive structure in American telephone service has set a new direction for the United States and possibly for international services. Regional satellite systems have appeared to complicate the role of INTELSAT. National satellite systems have continued to grow and have moved into the 11/14 GHz band. Direct broadcast of television signals to the home by satellite has emerged, become confused, and is changing in response to new technology. The space shuttle and Ariane rocket launchers have been proven, and provide important new access to space. New spacecraft/launcher concepts have appeared which present important system opportunities and economies. Communications satellite technology is steadily changing and will offer substantial opportunities for powerful new systems. Policy and technical innovation will continue and may significantly change the character of satellite communications systems before the end of this decade.

INTELSAT

INTELSAT is the telecommunications cooperative established by treaty to provide international communications service by satellite. Today it owns and operates 16 spacecraft in synchronous orbit, representing an investment of over 3 billion U.S. dollars. Besides handling two-thirds of all overseas telephone and data communications, it provides virtually all live overseas television. The ownership and use of INTELSAT facilities is widely shared among the members. Since 1979, INTELSAT membership has grown to 109 nations, and the members have built 140 additional antennas to handle the shared space segment. The group's traffic has doubled in 4 years, yet its communication charges have decreased, despite a 73 percent rise in the worldwide cost of living index.

INTELSAT has continued to support the development of communications satellite technology in a major way. Because of the consortium's unique service demands and traffic growth, INTELSAT spacecraft have consistently been developed at the leading edge of space technology. INTELSAT was the first to use synchronous spacecraft for commercial service (Intelsat I), the first to use channelized repeaters (Intelsat IV), the first to

exploit spatial reuse of frequencies (Intelsat IVA), the first to combine spatial and polarization frequency reuse (Intelsat V), and the first to sponsor international satellite switched TDMA—time division multiple access (Intelsat VI). Through its spacecraft development programs, INTELSAT has become one of the world's most important sponsors of communications satellite technology.

INTELSAT expects that its traffic will increase from the present 63,000 half-circuits to 500,000 by the end of the century. The growth will occur almost equally in the three ocean basin service areas. The organization expects television carriage to increase from 5 to 35 dedicated transponders in the next decade. The number of transponders leased for domestic service should double in the next 4 years. With this outlook and the remarkable accomplishments of the last 20 years, it is difficult to see INTELSAT as anything other than a resounding success. And yet it is entering a period of considerable uncertainty and anxiety.

The most immediate and worrisome threat to INTELSAT comes from the United States. Two organizations have filed applications with the Federal Communications Commission to build and operate satellites for business services across the Atlantic. More may follow. These firms propose to provide both private and public message services. They allege that the impact of their systems on INTELSAT revenues would be negligible. People who understand INTELSAT operations believe that this is illusory. Common rates for all INTELSAT links are the result of worldwide averaging, and the high density or major path routes support thin route or primary path satellites on which developing nations depend. This rate averaging was understood from the beginning by the nations which formed INTELSAT.

However, a different wind is blowing in the U.S. today. Competition in all phases of telecommunications is thought to be a good thing. The breakup of AT&T symbolizes that trend and is moving the U.S. away from domestic rate averaging in its telephone network. New legislation¹ has been considered by the U.S. Congress which would encourage the development of competitive international satellite services.

Sensing this change, the new system proposers seek to reap a bountiful harvest by serving only the lucrative transatlantic major path routes. The inevitable result of such traffic division would be to weaken the INTELSAT structure significantly. It would surely cause rates to rise in other parts of the worldwide system. The U.S. is thus caught in a dilemma. There is a basic contradiction between the deregulation/pro-competition philosophy being implemented at home and the treaty obligations championed by the U.S. in creating INTELSAT. The world is watching to see how this problem is resolved.

INTELSAT already faces competition from regional systems that have emerged in the last 4 years. These systems pose a problem for INTELSAT, which is charged with providing international service through a single integrated system. Starting in 1977, the Indonesian national system has provided satellite capacity to its neighbors on a transponder-lease basis.² This system also supports some communication between countries in Southeast Asia that might have been carried by INTELSAT. However, the

¹ Senate Bill 999, sponsored by Senators Goldwater of Arizona, Baker of Tennessee, Pressler of South Dakota, and Hollings of South Carolina.

² INTELSAT also leases extra capacity to member nations on an accommodation basis, but has no unique mandate to do so.

absolute magnitude of the traffic loss was unimportant.³

The first serious challenge from a regional system occurred when the Arab League decided to proceed with the Arabsat system in 1980. Arab nations presented good arguments that the traffic to be carried among the 21 Arab countries (see Figure 1) would not have gone on INTELSAT anyway, since these nations planned to build terrestrial microwave networks to handle the traffic if their satellite system proposal was turned down. Faced with the significant economic and political influence of the Arab nations, INTELSAT accepted the new system, which will be launched in 1984.

The same drama was reenacted during the past year by the 20 European countries which formed Eutelsat. They are building a K band satellite system with the coverage shown in Figure 1. The Eutelsat system provides an alternative to the well developed terrestrial system that connects the member nations. It may also supply new services, such as high speed digital transmission of business data and television distribution to Africa and the Middle East. In coordinating the system; Eutelsat noted that INTELSAT does not now carry intra-European traffic. Furthermore, the existing terrestrial network could continue to do the job, so INTELSAT will lose nothing that it might have had. The coordination of Eutelsat with INTELSAT has been difficult.

A similar question was raised for traffic between Canada, the U.S., and Mexico. INTELSAT held that satellite traffic between these member states should go by INTELSAT.

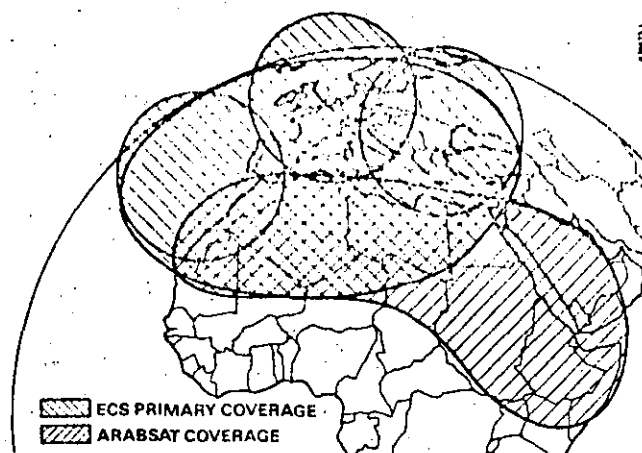


Figure 1. Coverage of Arabsat and Eutelsat Systems

Unfortunately, the consortium had no satellites properly positioned to supply such service, nor could it justify establishing them to do so. The telephone authorities pointed out that north/south traffic was flowing nicely on the terrestrial network and could easily continue without satellite augmentation. Satellite interconnections are now being negotiated bilaterally by satellite operators in the three countries.

What is difficult here is that the original philosophy of INTELSAT did not adequately address the issue of satellite connections between contiguous countries. The basic planning was for long, transoceanic routes. The problem of adjacent country connection is thus left to INTELSAT to negotiate with its member nations on a case-by-case basis. In doing so, some members appear simultaneously as breakaway petitioners and as INTELSAT shareholders in the debates that ensue.

INTELSAT faces other challenges. Fiber optic cables present serious economic competition to the major path satellite links operated by INTELSAT, since both connect only a few gateway stations. The circuit cost for undersea cables is dropping, and designs for branching cables that could connect many

³ For instance, it was substantially less harmful than the transfer of the Hawaii/continental U.S. West Coast traffic from INTELSAT to Comstar in July 1976.

points are coming. INTELSAT could easily meet the pricing challenge of undersea cables by building aerial cables. To be specific, a Delta class satellite with two reflectors would form two spot beams—one directed to Europe and one to the eastern U.S. Such a satellite has been discussed for at least a decade and would probably undercut cable costs. In doing so, however, it would destroy the very thing INTELSAT is trying to preserve: rate averaging over the entire world. It is an uncomfortable dilemma, especially since the cable owners are not so constrained. Some cable owners are also members of INTELSAT and must make difficult choices when they vote their INTELSAT interest.

The fundamental position of INTELSAT is extraordinarily strong. It is uniquely successful as an international commercial venture, returning to all of its shareholders a handsome return on their investments each year. It has a reliable, redundant system in place. It has a strong and growing business base. Its communications satellites are the most advanced now flying; those in development are even better. It is a going business, with an established procedure for collecting revenues, calling for capital contributions, buying satellites and launchers, and distributing earnings. With this enormous power it can move in many directions—if it does so carefully. The next 4 years will prove decisive for INTELSAT.

MOBILE SERVICES

Telecommunications service to mobile users—ships, airplanes, and surface vehicles—has always been one of the most important uses of the radio spectrum, simply because there is no other way for these vehicles to communicate. Satellites provide an important new capability for mobile users because of the broad access or geographic coverage

available from synchronous orbit. Satellite mobile service was first demonstrated experimentally by Syncom II in 1963 and subsequently with the ATS series. The U.S. Department of Defense furnished narrowband UHF service to military users with Tacsat in 1969. This continued with Comsat's Marisat and the Navy/Air Force Fleetsatcom; soon Hughes Communications, Inc.'s Leasat program will follow. However, civilian carriers were slow to provide such service.

It was Comsat which took the pioneering step by adding L band radio capability to the Marisat spacecraft, thereby delivering three-ocean maritime service from 1976 onward. The Marisat spacecraft were joined by the Marecs A satellite in 1981, and leased service on Intelsat V satellites in 1983.

Inmarsat has emerged as the international cooperative supplier of maritime voice and data service to ships at sea, as the result of many years of preparation by the International Maritime Organization. Like INTELSAT, its ownership is related to member use. It now provides high quality telephone and data service to 1,882 ships equipped with suitable terminals. It is a young organization and is growing rapidly. Inmarsat recently issued an international competitive tender for the next generation space segment. The next 4 years will be a period of significant growth and evolution for Inmarsat.

During the same period, almost no progress has been made on supplying public message service to aircraft in flight. There is no satellite service to civilian aircraft—and none planned, alas.

The third class of mobile satellite service is for land or surface vehicles. This possibility is being developed jointly by NASA and the Department of Communications in Canada.

Two important questions face such a service: 1) how it will relate to the terrestrial cellular radio system serving the same class of users, and 2) whether it can become a viable commercial activity or must remain a government-subsidized service. These questions are likely to find answers before we meet again in 1987. My impression is that there is a valid need for satellite service. It should supplement cellular radio and probably use the adjacent bands at 850 MHz. I believe that the initial service should be established with modest channel capacity and small spacecraft.

There is another consideration. Because user equipment will probably be omnidirectional, all users will see all satellites operating on their side of the earth, unless the satellite can form narrow beams at UHF to divide the

coverage area. This means that there may be only one or two suitable orbit positions in each hemisphere. These must be shared cooperatively among the nations seeking to establish mobile service.

NATIONAL SYSTEMS

National systems which provide domestic telecommunications service by satellite have proliferated and expanded rapidly in the past 4 years. Table 1 lists the number of satellites in domestic service in October 1979, those active today, and those projected for October 1987. In constructing this summary, it was difficult to differentiate between experimental programs and those in operational service. The forecast for 1987 was especially difficult, because some nations and organizations

Table 1. National Communications Satellites

	October 1979	October 1983	October 1987
Argentina			2
Australia			2
Brazil			2
Canada	4	5	5
France			2
Germany			1
India		1	2
Indonesia	2	3	2
Italy			1
Japan		2	2
Mexico			2
Nigeria			2
Pakistan			2
U.K.			2
U.S.	8	21	42
Totals	14	32	75

discuss plans for building domestic systems without actually committing the large amounts of needed capital. However, the number of nations that lease transponder capacity from INTELSAT affords a good indication of serious intent.⁴ Twenty-four nations now lease the equivalent of nearly 34 full transponders from INTELSAT for domestic service.

The significance of Table 1 is not in its detail, but its trend. The number of national systems is accelerating. They are doing so because they are an economical way to build long distance networks rapidly, both in developing nations and inaccessible regions of advanced nations.⁵ In countries with existing terrestrial systems, like Japan and the U.S., satellites provide a simple way to establish new services with separate nationwide networks.

Two trends have characterized the evolution of national systems since 1979. The first is the start of K band service. Canada and the U.S. have both established services at 11 and 14 GHz. SBS now operates three such spacecraft and Telesat Canada is using two Anik C satellites. Eutelsat has just established its own K band system. These users have found that the increased attenuation experienced at K band is offset by the ease of locating earth stations in urban areas. A considerable number of K band systems are now being built: Australia's Aussat, England's Unisat, and the American GTE Gstar and RCA Americom systems.⁶

The second major trend in domestic systems is the introduction of new modulation techniques. The initial systems all used frequency modulation. Indonesia's Palapa system pioneered demand assignment service on one transponder in 1976 and is now preparing to enlarge that capability. A major change was introduced by Satellite Business Systems, which inaugurated full K band TDMA service in early 1981. This TDMA system provides high quality voice and data service to some 107 sophisticated stations in the U.S. Telesat Canada began similar C band service earlier with Anik A. American Telephone and Telegraph recently announced its intention to use single sideband amplitude modulation. Exploiting the unusual linearity of the solid state power amplifiers carried on its new Telstar 3 spacecraft, AT&T believes it can carry 6,000 half-circuits on each 36 MHz C band transponder, in contrast to the maximum (single carrier) capability of 1,000 half-circuits in the same transponder using frequency modulation.

An unexpected but significant policy development for national systems occurred in the U.S. In the traditional ownership pattern, a few large communications carriers owned spacecraft and leased services on a tariff basis. A number of major users became concerned about this approach when Satcom III failed to achieve orbit in 1979 and there was a sudden shortage of transmission capacity for video programming. The concern was aggravated by the uncertainty of future satellite access and tariff charges. Hughes proposed that users be allowed to buy and own individual transponders. For users who did not need the capacity of an entire satellite, this had several benefits. Users could control their own transmission capacity and accurately anticipate its cost. They could also enjoy the tax benefits of ownership. This condominium approach to satellite service

4 Brazil, Mexico, Australia, Nigeria, France, and India all leased INTELSAT capacity before proceeding with their own space programs.

5 I.e., Australia and Canada.

6 Plus K band components of hybrid spacecraft—GTE Spacenet, American Satellite, Mexico, and Telecom 1.

has broadened the participation of American firms in satellite communications and is stimulating new applications.

The industrial firms responsible for building the current generation of national and regional communications satellites are summarized in Table 2. It is a very competitive field in which price is usually the deciding factor. Two firms have shared most of the spacecraft sales so far: Hughes and RCA of the United States.

DIRECT BROADCAST SATELLITES

The initial direction for direct broadcast satellites was set in 1977, at the special World Administrative Radio Conference. It established transmission standards and allocated orbit and frequency combinations for all nations in Europe, Africa, and the Far East. Primarily at the request of the U.S., allotments for the Western Hemisphere were delayed until a special conference that was held this year.

A great deal has happened technologically in the intervening six years, and this was reflected in the different standards established by the two conferences. The same technical progress probably accounts for the difference of views between Canada and the U.S. It certainly explains the continuing confusion within the American DBS community. In short, we are in a period of extraordinary change in a field that was considered settled in 1977.

Impetus for this change is the dramatic improvement in ground station performance. In 1977, it was thought that a receiver noise figure of 6 dB was achievable. Proceeding on that assumption and conservative estimates of system losses, it seemed that equivalent isotropic radiated power levels of 63 to

65 dBW would be required to provide satisfactory television reception. With antennas that cover average-size countries or the time zones of larger countries, logic led to a judgment that traveling wave tube amplifiers of 230 watts or higher would be required for each television channel.⁷ Germany and France embarked on the development of such tubes. They also began a joint program to build direct broadcast satellites using this technology, which are now planned for launch in 1985.

Since that initial judgment was made, several things have changed. First, the DBS receiver noise figure has improved to 3.5 dB and may drop to 2.5 dB in the next few years. The second change resulted from a more realistic evaluation of system losses, reflecting video transmission experiments made with the Canadian Technology Satellite. That spacecraft carried both 200-watt and 20-watt amplifiers. Surprisingly, the Canadians found that the 20-watt channel provided high quality DBS service. Telesat Canada implemented operational 20-watt K band video service on the Anik B spacecraft in 1980 and is continuing that service on Anik C. When Australia was establishing its satellite standards for outback television distribution, Canada positioned the CTS over Australia for several months. The Australians got the same high quality and are building their DBS service around 30-watt traveling wave tube amplifiers.

As 1983 began, DBS plans in the United States were in a state of confusion. Eight organizations* had applied to the FCC for permission to operate such systems and were granted provisional construction permission

7 Japan's BS-1 experimental system, which flew in 1978, was based on 100-watt tubes.

8 CBS, Comsat, DBS Corp., Graphic Scanning, RCA, USSB, Western Union, and Video Satellite System.

Table 2. Companies Building National and Regional Communications Satellite Systems

Country System	Space-craft	RCA	Hughes	Spar	Ford	Melco	BAe/Matra	SNIAS
Canada								
Anik C	3		3					
Anik D	2		2	2				
U.S.								
WU Westar	4		4					
RCA C Band	4	4						
SBS	6		6					
AT&T Telstar	3		3					
HCI Galaxy	3		3					
GTE Gstar	4	4						
GTE Spacenet	4		4					
ASC	2		2					
RCA K Band	3	3						
Indonesia								
Palapa	2		2					
Brazil								
SBTS	2		2	2				
Australia								
Aussat	3		3					
Mexico								
Morelos	2		2					
India								
Insat	3		3		3			
Japan								
Sakura 2	2		2			2		
CS-3	2		2			2		
Arab League								
Arabsat	3		3					3
Europe								
Eutelsat	5		5				5	
France								
Telecom	4		4				4	
U.K.								
Unisat	2		2				2	
Totals	68	17	26	4	3	4	11	3

in November 1982. Of the eight approved DBS applicants, only Comsat STC is actually building satellites to provide such service: the others are watching. The STC design was based originally on 3 channels with 230-watt amplifiers.

Aside from technical considerations, there is a troubling question about the program content DBS operators will offer. American television networks spend \$600 million to \$800 million each year to program a single TV channel. Current experience of American cable operators suggests that the public's appetite for multiple channels is limited. The basic question is whether DBS operators can deliver programming of satisfactory quality and find sufficient consumer acceptance for their systems.

The current DBS satellite programs are summarized in Table 3. Most of the high power DBS spacecraft are quite different from the spacecraft that provide point-to-point service. This is shown by the plot of satellite weight versus power in Figure 2. All the point-to-point satellites, from Early Bird to Intelsat VI, lie roughly along a straight line. Adding channels to a communications

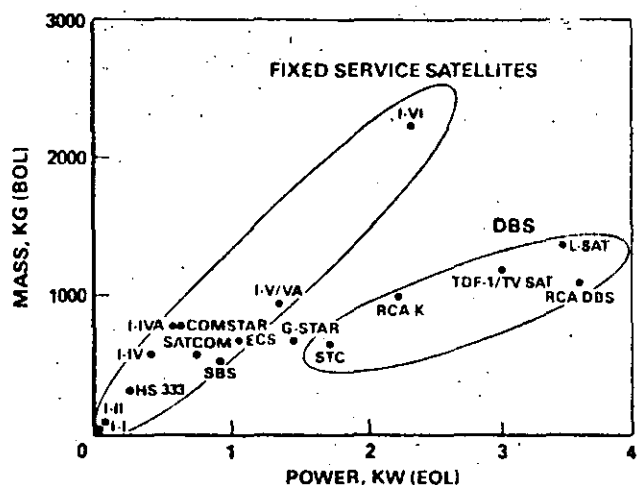


Figure 2. Weight and Power Relationship of Direct Broadcast and Fixed Service Satellites

satellite with an established ground network adds weight and power in equal measure. In the case of DBS service, the proposal is to establish a completely new ground network with a great many small earth stations. The DBS emphasis so far is on satellite power. Weight is secondary, as long as the heavy batteries needed to carry the service through eclipse are not supplied. A DBS spacecraft based on the 1977 WARC is a high power, on-off, small channel capacity, relatively lightweight satellite.

Table 3. Direct Broadcast Satellite Programs

Country	Program	Spacecraft	Channels	Tube Power, w	EIRP, dBW	First Launch
Canada	Anik C-2	1	16	15	48	Jun 83
Japan	BS 2	2	2	100	55	Feb 84
Australia	Aussat	2	4*	30	47 to 49	Mid 85
Germany	TV SAT	1	3	230	63 to 64	Late 85
France	TDF-1	1	3	230	63 to 64	Late 85
U.S.	STC	2	3	230	54 to 56	Jan 86
Scandinavia	TELE-X	1	2	230	63 to 64	Mid 87

*Each of the two operational spacecraft can devote its four high power channels to DBS, while its other channels provide fixed service.

As the saga of DBS standards unfolds, it will be interesting to see how the concept of spacecraft weight and power changes. My view is that the DBS spacecraft of tomorrow will lie closer to the fixed service satellite line of Figure 2. I believe that a single modern spacecraft configuration can serve both needs.

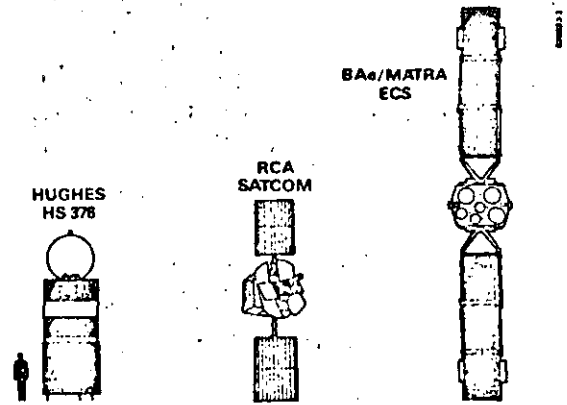
SPACECRAFT

Current Domestic Systems

The 4 years just past have seen the introduction of several spacecraft for national and regional markets. Three generic communications satellites have been proven in space and are summarized in Table 4 and Figure 3.

The RCA Satcom is a body stabilized spacecraft that has evolved steadily since it was first flown in 1975. Its weight has grown as the rocket launchers have been upgraded. The spacecraft power has increased significantly by panel extensions to support more powerful and diverse payload combinations. The current version of Satcom is designed to fly on the Delta 3920 series, on Ariane, or on the shuttle with a PAM-D. It uses a solid propellant apogee motor and electrically heated hydrazine thrusters.

Figure 3. Scale Comparison of Three Current Domestic Spacecraft



Nickel-hydrogen batteries have replaced nickel-cadmium cells. It is basically a 24-channel crosspolarized C band spacecraft, although K band and hybrid versions are also being produced. Later Satcom versions permit in-orbit antenna beam reconfiguration to accommodate different orbital assignments. The customer base for RCA Satcom is shown in Table 5.

The Hughes HS 376 satellite design was begun in 1977 to provide a completely new transition spacecraft—one that could fly equally well on the Delta 3920, Ariane, or space shuttle. It uses a telescoping solar panel to double the prime power normally expected of a spinner. This feature and its

Table 4. Generic Communications Satellites

Builder	RCA	Hughes	British Aerospace/ Matra
Satellite	Satcom	HS 376	ECS
Total weight, kg	598 to 670	540 to 661	610 to 680
Total power, w	1000 to 2260	900 to 1118	1100
First launch	Oct 82*	Nov 80	Jun 83
Lifetime, years	10	7 to 10	7

*RCA considers Satcom V the initial spacecraft of its advanced Satcom series.

Table 5. Customers for RCA Satcom Spacecraft

Owner	Name	Spacecraft	Payload	Channels	First Flight
RCA Americom	Satcom	4	C	24	Oct 82
GTE Spacenet	Spacenet	4	C/K	18/6	Apr 84
General Telephone	Gstar	4	K	16	Mar 84
American Satellite		2	C/K	18/6	Sep 85
RCA Americom		3	K	16	Sep 85
Comsat STC		2	DBS	3	Jan 86
Total number of spacecraft		19			

fold-down reflector permit a more compact launch configuration to fit the volume limitations of its three carriers. Both 24-channel crosspolarized C band and K band versions have been built. The HS 376 uses a solid rocket motor for apogee impulse and nickel-cadmium batteries. It uses monopropellant hydrazine for orbit adjustment. Operators and purchasers of the HS 376 are shown in Table 6.

The British Aerospace/Matra ECS program began in 1977 with the orbital test satellite (OTS) program sponsored by ESA. The same basic vehicle was later adapted to provide L band maritime service in the Marecs program. Telecom 1 is another OTS derivative and is being developed for French national service. The ECS for Eutelsat is an OTS derivative with two three-panel sun-tracking solar array wings. Power is increased in

Table 6. Customers for Hughes HS 376 Spacecraft

Owner	Name	Spacecraft	Payload	Channels	First Flight
Satellite Business Systems	SBS	6	K	10 to 14	Nov 80
Telesat Canada	Anik C	3	K	16	Nov 82
Western Union	Westar	4	C	24	Feb 82
Indonesia	Palapa-B	2	C	24	Jun 83
Brazil*	SBTS	2	C	24	Feb 85
Mexico	Morelos	2	C/K	18/6	May 85
Australia	Aussat	3	K	15	Jul 85
Telesat Canada*	Anik D	2	C	24	Aug 82
Hughes Communications	Galaxy	3	C	24	Jun 83
AT&T	Telstar 3	3	C	24	Jul 83
Total number of spacecraft		30			

*HS 376 is built under license by Spar Canada for these customers.

subsequent ECS derivatives by adding panels to the wings. This generic spacecraft has grown in mass from 443 kg to 680 kg and in power from 750 watts to 1,300 watts. The satellite bus is a cylindrical central thrust cone surrounded by an equipment platform. Two corotating momentum wheels provide attitude control. The ECS employs a solid rocket motor for apogee impulse and 16 thrusters for stationkeeping. The users of the BAe/Matra spacecraft are shown in Table 7.

The Arabsat three-axis spacecraft being constructed by Aerospatiale (SNIAS) is sized to fly on Ariane and will have a mass of 1,134 kg in synchronous orbit. It will use a solid apogee rocket and 12 thrusters for orbit control. Its solar panels will provide 1.3 kilowatts of prime power and its energy will be stored in nickel-cadmium batteries for eclipse operation. So far, it has found only one customer.

The Indian satellite built by Ford is a very special body stabilized spacecraft that provides point-to-point communication, direct broadcast, and weather monitoring services—all in one satellite. Because of this specialization, it has found no other market, although some of its design has been applied to Arabsat.

Future Domestic Systems

A new generation of spacecraft is now being developed for the national and regional market by ESA, BAe Matra, Hughes, and Ford. Their designs have not yet been completely revealed, but the following information is available.

The new Ford Supersat is a body stabilized spacecraft based on the Intelsat V design. The goal for this program is a flexible, body stabilized spacecraft that is optimized for the shuttle. It will use a liquid bipropellant system for perigee impulse that is being developed jointly by Ford and Aerojet. The same bipropellant motors will be used for apogee impulse, after some tankage is staged in transfer orbit. With varied propellant loading, the spacecraft will offer a considerable range of payload weight capability. At the lower end of the scale, it will provide the capability of Intelsat V: 950 kg and 1.6 kilowatts. At the upper end of its capability it will weigh 1,528 kg and produce as much as 8 kilowatts of prime power.⁹ The spacecraft will use a centralized digital

⁹ In the configuration proposed for a U.S. domestic hybrid system.

Table 7. Customers for BAe/Matra ECS Spacecraft

Owner	Name	Spacecraft	Payload	Channels	First Flight
ESA	OTS	2	K	6	May 78
ESA	Marecs	3	L	40 voice	Dec 81
Eutelsat	ECS	5	K	12	Jun 83
French PTT	Telecom 1	4	C/K/X	4/6/2	May 84
United Satellite Ltd	Unisat 1	2	DBS/K	2/4	Aug 86
Total number of spacecraft		16*			

*Two versions of ECS are also being built for a British military mission (Skynet IV).

processor system which will combine telemetry and control functions, attitude control computation, and power management in a single unit.

The newest Hughes satellite—the HS 393—is a spinning vehicle. It is designed to fill the gap between the HS 376 currently being mass-produced for domestic service and the large Intelsat VI. It will fly on the shuttle with a 25 percent load factor or in half of the Ariane 4. On the shuttle, it will use integral propulsion with a Minuteman III solid rocket motor for perigee boost. It will use nickel-hydrogen batteries and a bipropellant system for apogee impulse and on-orbit stationkeeping. The HS 393 will weigh 1,361 kg and generate 2,800 watts of prime power at the beginning of life in synchronous orbit.

RCA has briefly described the company's next steps in the Satcom evolution.¹⁰ RCA's full direct broadcast version¹¹ is apparently based on a liquid perigee stage to place the spacecraft in transfer orbit after its ejection from the shuttle. RCA is also considering the new PAM-D2 as the perigee stage for its upgraded spacecraft. This would give it about 50 percent more payload than the present generation of spacecraft.

The BAe/Matra team is also upgrading the basic ECS spacecraft for greater payload capability. The Eurostar is being designed for launch by Ariane 4 or by shuttle with a PAM-D2. Initial applications are for the United Kingdom's Unisat and the French experimental communications satellite

Athos. The Unisat mission driving force is direct broadcast TV requirements. Unisat will have a launch mass of 1,582 kg and is in the midground of the Eurostar design.

INTELSAT Spacecraft

Two important new INTELSAT vehicles have emerged in the last 4 years. The Ford Intelsat V spacecraft flew first in 1980, and each of its successive six flights has been successful. INTELSAT contracted with Ford to upgrade the basic spacecraft to the Intelsat VA configuration, which exploits the increased lifting capability of the Atlas Centaur and Ariane.¹² Communications payloads are being added to the Intelsat V and VA series to provide L band maritime and K band spot beam international business service, and increases in the global C band service. The 15-spacecraft Intelsat V and VA series is summarized briefly in Table 8, and the entire INTELSAT family is compared in Figure 4.¹³

Intelsat VI is the largest communications satellite program ever undertaken. The development, engineering, and production of the first five spacecraft is covered by a \$700 million contract. It is the largest and most complex spacecraft yet built for commercial service. When launched by the shuttle, it uses integral propulsion and provides its own perigee impulse with a large solid rocket motor. It will use the satellite's own guidance system, initiated by the shuttle's precise reference. When it flies on Ariane 4, it will not need this motor, since Ariane will place

10 "RCA's Approach to Increased Communications Satellite Performance," by Jack A. Frohbieter, RCA Astro-Electronics, Satellite Communications Conference, Ottawa, Canada, June 14 to 17, 1983.

11 In contrast to the interim weight and power configuration RCA is building for Satellite Television Corp.

12 Initial plans to fly the Intelsat V series on the shuttle were abandoned because the PAM-A horizontal launch configuration and the spacecraft modifications needed for shuttle launching were too costly.

13 "In-orbit Operation and Test of Intelsat V Satellites," by Leonard R. Dest and S. Erland Magnusson, Ninth Communication Satellite Systems Conference, San Diego, March 7 to 11, 1982.

Table 8. Comparison of Intelsat V/VA and Intelsat VI Spacecraft

	Intelsat V	Intelsat VA	Intelsat VI
Builder	Ford	Ford	Hughes
Atlantic capacity (half circuits)	25,000	30,000	80,000
No. being built	9	6	5
First flight	1980	1983	1986
Bandwidth, MHz	2321	2570	3262
Initial mass in orbit, kg	950	950	2243
Total power available, w, EOL	1354	1354	2300
Lifetime, years	7	7	10
Launcher	Atlas Centaur or Ariane 1	Atlas Centaur or Ariane 2	STS (46%) or Ariane 4

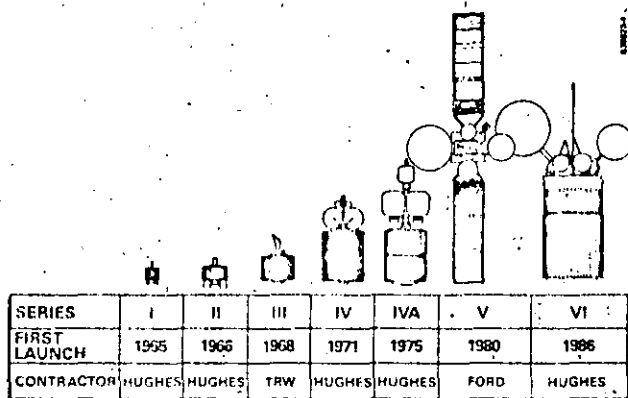


Figure 4. Evolution of INTELSAT Spacecraft

its 3,720 kg directly into transfer orbit. For both launchings, apogee impulse will be generated by two bipropellant thrusters. The same bipropellant system will later feed small thrusters for orbital adjustment. Intelsat VI will use nickel-hydrogen batteries and will be the first INTELSAT spacecraft to employ RF beacon tracking for precise attitude control.¹⁴ It has a satellite switched TDMA and a completely reconfigurable antenna for the three ocean basin operating areas. The

antenna provides sixfold frequency reuse by polarization and spatial diversity. Considerable growth capability was built into Intelsat VI for the evolving communications needs of international users.

New Large Spacecraft

In addition to Intelsat VI, three other large spacecraft are being developed which will supply worldwide service from synchronous orbit: 1) the TRW Tracking and Data Relay Satellite; 2) the British Aerospace Olympus spacecraft, and 3) the Hughes Leasat. They each use the increases in payload and volume capability provided by the space shuttle and later versions of Ariane. Their characteristics are summarized in Table 9 and Figure 5, where they are compared with Intelsat VI. The economics of each is closely tied to the trend in launch vehicles.

The TDRSS spacecraft is a body stabilized vehicle whose multiple antennas provide two-way communication and data services for the space shuttle and for unmanned low altitude spacecraft. The first TDRSS was

14 Better than 0.1° even during orbit maneuvers.

Table 9. Characteristics of New Large Spacecraft

	TDRSS	Olympus	Leasat	Intelsat VI
Builder	TRW	BAe	Hughes	Hughes
Weight, kg, BOL	2273	1454 to 2000	1315	2243
Power, w, EOL	1700	2300 to 7000	1063	2300
First launch	1983	1987	1984	1986
Launcher	STS/IUS	Ariane 3/4	STS	STS or Ariane 4

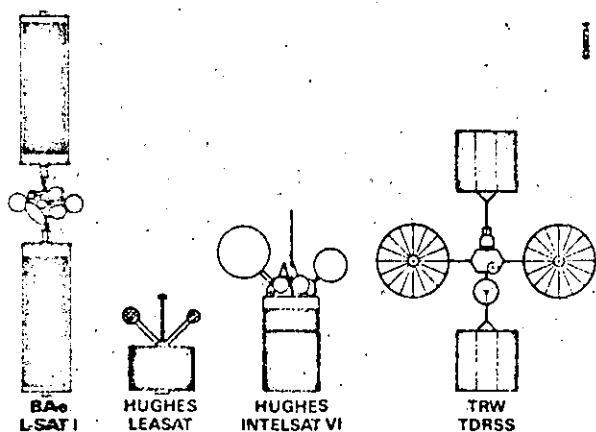


Figure 5. Scale Comparison of Four Large New Spacecraft

launched in April 1983. Its initial in-orbit weight is essentially the same as Intelsat VI. Because NASA elected to launch it with the shuttle and the IUS stage, it has proven to be a very expensive system. The difference in launch costs for these large new spacecraft is shown in Figure 6, which plots 1986 launch costs in 1982 U.S. dollars. TDRSS and Intelsat VI will have about the same initial weight in orbit. However, the combination of a long payload and the enormous cost of the IUS stage (assumed here to be only \$60 million) produces an \$89 million difference in launch costs between the two.

Olympus is a general purpose, body stabilized spacecraft whose development by British Aerospace is sponsored by ESA. It is designed to carry a wide variety of communications payloads within its weight and power boundaries. The first applica-

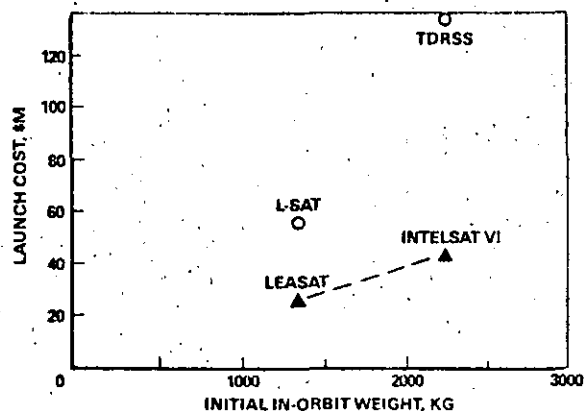


Figure 6. Launch Cost Versus Weight for Various Large New Spacecraft

tion, called L-Sat, is planned for both point-to-point services and direct broadcast applications. It is designed to fly on Ariane 3 and 4 in 1986, but can also ride on the shuttle with an IUS.

By contrast, Leasat is a shuttle-only vehicle designed specifically to minimize launch cost. The 4.27-meter diameter cylindrical spacecraft just fits within the 4.57-meter inside diameter of the shuttle bay. With its solid perigee motor it weighs 6,818 kg and occupies 25 percent of the shuttle bay. The payload for the five Leasat spacecraft is UHF for U.S. naval service, although the large deck offers great design flexibility for other antenna combinations. The spacecraft employs integral propulsion and the Frisbee ejection technique. Leasat has two significant economic advantages. Its shuttle user charge is low because it occupies a minimum length

in the orbiter bay corresponding to its payload weight. Secondly, the user need *not* pay for a separate perigee stage.

Spinning Versus Body Stabilized

A few satellite issues seem to have resolved themselves. Four years ago, earnest debates were still heard about the relative merits of body stabilized and spinning satellites. That debate has been largely ended by the configuration choices that sophisticated owner/operators have made. Body stabilized and spinning spacecraft have divided the national markets almost evenly. INTELSAT went from spinners to body stabilized and then back to spinners. American naval service has gone from spinners to body stabilized and back to spinners. What these market decisions show is what thoughtful people have known for a decade: Most satellite tasks can be done with either technology. A few missions are best done with one; i.e., synchronous weather satellites are most easily built as spinners, while very large antennas are most easily supported by three-axis spacecraft. For everything else, it is primarily the builder's choice, which he makes based on experience. The rhetoric of the past is now seen for what it probably was: an attempt to *differentiate* the satellite products of companies which wished to enter the field.

Clusters Versus Platforms

A new debate is taking shape for satellite system planning. It is sometimes characterized as the choice between platforms and clusters. More properly, it is a discussion about how large individual spacecraft should become.

The point is that we need *not* place all the transponders needed at a particular orbital

position on a single spacecraft. We now place all the transponders on one platform because of the perceived economics of shared housekeeping functions: power and attitude control. We could just as well put half the transponders on one satellite, half on a second. We could then place the two spacecraft near each other in space, so that they appear as one from Earth. Relative orbit control of such neighboring satellites is a technology that is in hand. Interconnection of transponders on the separate spacecraft can be completed by short distance radio links if required—again a proven technology. We can thus fractionate a large spacecraft into modules. The choice of whether to do so is an economic one.

The economics are influenced by several issues. The first is the risk of catastrophic failure, i.e., too many eggs in one basket. A second risk is the cost of replacing a system in the event of partial failure. What should be done if one service fails but the rest of the satellite is fine? The third issue is the flexibility provided by clusters when system needs change in unplanned ways. With modular spacecraft, one service can be augmented in response to rapidly changing demand without disrupting the other service components of the system—or starting all over too soon with an even larger spacecraft.

It is my view that economics will favor modular systems over large single spacecraft. I believe that the economics of partial replacement and flexible growth clearly overshadow the modest economy of scale now provided by a single spacecraft. However, others hold contrary views, and the proposition will be debated extensively. It will probably be subject to its first decision in the international arena, where accelerating traffic demands propel satellite planning. INTELSAT is now studying platform options with roughly five times the communications

capacity of Intelsat VI. The alternative is to consider Intelsat VI itself a module for the INTELSAT communication nodes in space and connect the modules with intersatellite radio links.

SATELLITE TECHNOLOGY

It is useful to review the basic technology improvements that have become available in the last 4 years. I shall also try to project how these technologies will unfold in the future.

Power

Prime power for communications satellites is generated by solar cells responding to the sun's rays. Silicon solar cells have been improved for 25 years, as shown in Figure 7. However, it would seem that we have wrung as much performance from silicon cells as we can. It was long recognized that a new material was required to further increase the efficiency of solar cells. The best choice was identified as gallium arsenide, and cell development has been proceeding for 8 years. The first GaAs flight cells are now becoming available in usable quantities. They have a conversion efficiency of 18 percent, which is expected to improve with time, and exhibit 50 percent less degradation in the face of severe radiation and thermal environments. Significant production of these new cells is now beginning. It is hoped that their high price can be brought down and their thickness reduced to justify their operational application.

The corollary to power generation is electrical storage, since geosynchronous satellites pass through Earth's shadow 90 times each year for varying lengths of time. Nickel-cadmium batteries have been the traditional electrical storage device. In the past 4 years, a new solution to battery needs has been perfected

and committed to flight projects (Figure 8). The nickel-hydrogen battery provides twice the energy density of the older cells, because it can be discharged to 70 or 80 percent of its capacity. Life tests show that these new cells are less sensitive to charge and discharge cycles, and it is believed that they can support 15-year missions. Nickel-hydrogen batteries are probably the only solution for satellites that must store more than 2 kilowatts. Looking to the future, we expect progressive improvements and scale-ups of nickel-hydrogen cells. Batteries based on zinc/bromine and lithium may provide weight-to-power reductions of 50 to 75 percent in the next decade.

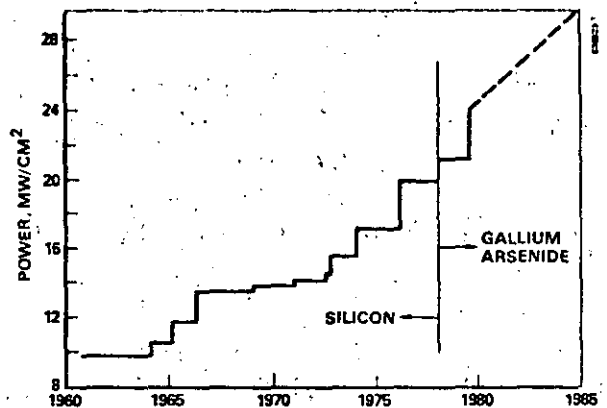


Figure 7. Solar Cell Efficiency Progression

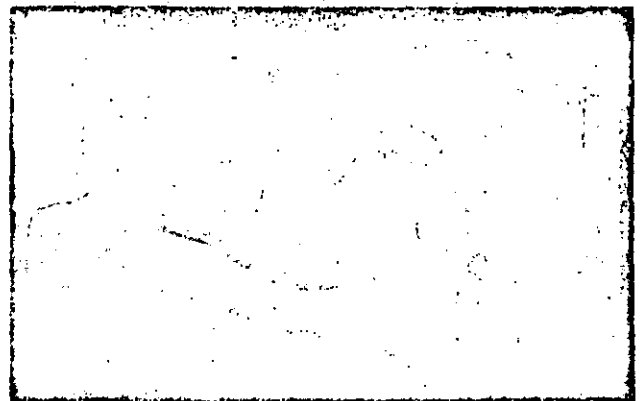


Figure 8. Nickel-Hydrogen (Left) and Nickel-Cadmium Battery Cells

Propulsion

Propulsion subsystems available today are much improved over those current in 1979, and most satellite programs are moving to incorporate the new technology. The major shift is from solid propellant apogee rockets to bipropellant thrusters—a technology first demonstrated by Symphonie in 1975. There are several reasons for changing to bipropellants now.¹⁵ First, thrusters have been developed that impart satisfactory stability and reliability. Second, bipropellants provide an improvement in specific impulse over solids (320 seconds versus 293 seconds.) Third, the center volume of modern satellites is usually occupied by the solid propellant perigee motor. The apogee motor must be wrapped around this cavity, and the only way to do so is with a radially distributed system of liquid tanks, lines, valves, and thrusters. The fourth important reason lies in the option of using the engines for multiple firings. Bipropellant thrusters can be fired to add velocity to the perigee impulse if the solid motor is not perfectly matched to the spacecraft, and are then fired again for apogee impulse.

The conversion from monopropellant hydrazine to bipropellant thrusters for stationkeeping and attitude adjustment is a second new development. Now that reliable, long life bipropellant thrusters are available in the 4 to 22 Newton class, the specific impulse advantage (290 seconds versus 220 seconds) of the new technology is commanding.¹⁶ The propellants remaining in the tanks after apogee burn can be used by the stationkeeping thrusters, so almost no propellant need be wasted.

An alternative approach is to use electrically heated monopropellant hydrazine thrusters for stationkeeping and orbit control. The concept is to use excess electrical power produced during sunlit conditions to heat the hydrazine and thus obtain a 25 percent increase in specific impulse. This was planned for Intelsat V, but its development was slow. Only now are reliable devices becoming available, as evidenced by their application in Satcom IR and IIR.

20/30 GHz Band

The enormous potential of communications satellites operating at 20 and 30 GHz (i.e., Ka band) has been apparent for a decade. People were first attracted by the large bandwidth allocation. With the small wavelength, they could also imagine forming multiple beams with modest antennas and using this band over and over. What was not known was the extent of signal attenuation in the atmosphere. Fortunately, Bell Telephone Laboratories installed 20 and 30 GHz beacons on the Comstar satellites. With their own ground stations and a collaborative data collection effort around the U.S., Bell mapped out the seasonal, diurnal, and geographic statistics of signal attenuation over a 5-year period.¹⁷ This significant set of experiments cast the new band into a rather different light. Bell found that propagation was interrupted by rain too often to permit transmission that was up to AT&T telephone standards (99.99 percent). With a 15 dB margin it might be possible to achieve a one-way availability of 99.90. However, the data show clearly that even adding an additional 20 dB margin would not yield

15 Nitrogen tetroxide for oxidizer and monomethyl hydrazine for fuel.

16 Insat used this approach, and so will Intelsat VI.

17 "Results from the 19- and 28-GHz Comstar Satellite Propagation Experiments at Crawford Hill," by Donald C. Cox and Hamilton W. Arnold, Proceedings of the IEEE, Vol. 70, No. 5, May 1982.

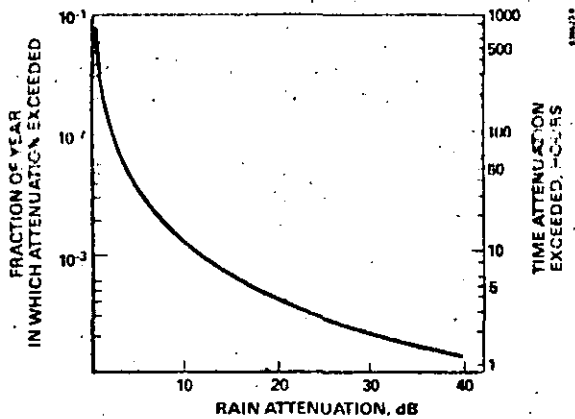


Figure 9. Ka Band Rain Attenuation Data Gathered by Bell Telephone Laboratories

99.99 percent (see Figure 9). Furthermore, the worst fades occur in the afternoon during the peak East Coast-to-West Coast traffic. The initial hope had been to avoid rain outages by using diversified reception with two or three separated stations. However, the measurements showed that rain cells are too extensive to permit this solution.

Several American companies have recently applied for authority to use the new band. A number of satellite systems are already planned by other countries. Japan launched its Sakura-2 satellites this year, each of which carries six Ka band transponders served by 6-watt traveling wave tubes. Italy is planning a domestic satellite system that will provide redundant transponders with 20 and 30 watt amplifiers. Germany's Postsat system will have a 20/30 channel. NASA is planning an experimental satellite, ACTS, which would demonstrate 20/30 GHz communications and sophisticated baseband signal processing/switching techniques.

My belief is that 20/30 GHz will eventually become an incredibly valuable communications resource. Our frustration so far has been in trying to make Ka band do traditional jobs. I believe that commercial systems using the new band will appear in the 1990's.¹⁸ It will be used for new services, such as

teleconferencing and non-real time video transmission. These require very large bandwidths and can stand the occasional outage (3.5 hours per year) of 20 dB or more. In the meantime, the basic components for receiving at 30 GHz and transmitting at 20 GHz are being developed in government-supported programs.

Beam Changing in Orbit

The technical possibility of modifying a satellite's coverage pattern after launch is now becoming an exciting reality. Such modification can provide significant flexibility for domestic satellites that must be built to operate at any position in a wide orbital arc. With 3 years required to build satellites and a late regulatory decision on location, antenna tuning represents a major attraction compared with simply averaging—and thus degrading—a satellite's beam to operate equally well over a wide arc.

INTELSAT must have spacecraft which can operate interchangeably in its three ocean basins, in which the earth station complexes and coverage requirements are quite different. Modest beam changing capabilities were included in the C band satellites developed a decade ago: Intelsat IVA and Intelsat V both have feed horns and therefore special coverage patterns that can be switched in or out by ground command.

The technology being employed on Intelsat VI is spectacular by comparison. An array of 43 horns is used for the transmit antenna and a similar number for the receive antenna (Figure 10). Each horn is excited with the appropriate amplitude and phase by a distribution network approximately 2 meters square. INTELSAT VI carries four such layered feed networks to provide the

¹⁸ Just as Ku band systems began to appear in 1980.

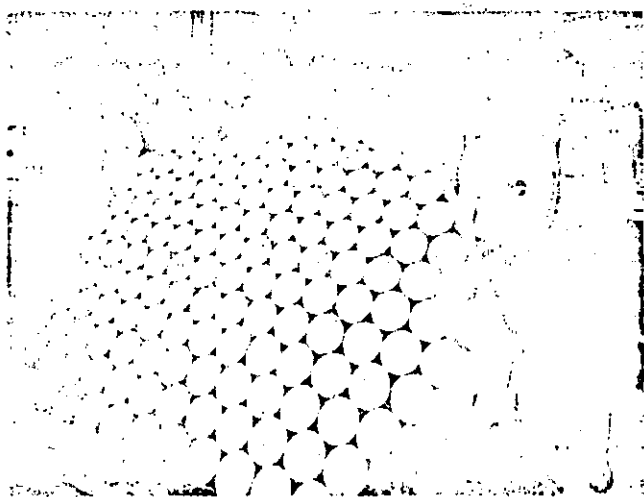


Figure 10. IntelSat VI Transmit Feed Array

appropriate phase/amplitude distribution for the operating regions. Ground commands can mechanically activate whichever feed distribution network is desired, and thereby produce the antenna pattern appropriate to each operating ocean basin.

Looking further to the future, beam modification can be done by completely electronic means. The possibility of a phased array in which the beam can be instantly reformed on command is becoming a reality. With the advent of solid state power amplifiers, the potential of placing any transponder into any beam is not far away. The operational opportunity of adjusting a satellite's coverage and capacity to match rapidly changing traffic requirements or interference problems is thus becoming available.

Transmitter Amplifiers

Solid state power amplifiers (SSPAs) based on gallium arsenide field effect transistors have been developed and flown since 1979. Satcom V employed 8.5-watt SSPAs. The Telstar 3 series employs 5.5-watt SSPAs, and IntelSat VI will use 1.8- and 3.2-watt SSPAs for its low power transponders. The expectation is that

SSPAs will provide longer life and greater reliability than traveling wave tube amplifiers. The significantly greater efficiency of TWTAs is offset by the superior linearity of SSPAs.

In the future, I expect the performance margin between SSPAs and TWTAs to narrow. Our ability to produce flight quality SSPAs will be extended to Ku band and eventually Ka band. We can build 16-watt amplifiers at 15 GHz today with 15 percent efficiency. Likewise, it is possible to build 3-watt amplifiers at 20 GHz with 12 percent efficiency. This technology will move ahead rapidly; it should provide operationally useful SSPAs at K band in the next 4 years—and useful 20 GHz devices by 1990.

Another important step has been linearizing the output amplifiers. Techniques have been developed for improving the linearity of both solid state and TWT amplifiers. Linearity improvement provides greater communication and is especially critical to modulation techniques like single sideband amplitude modulation, which depends critically on linearity in the carrier-to-intermodulation ratio over the communication bandwidth.

Signal Demodulation and Processing

The first TDMA system is now operating. In the SBS system, the receive and transmit beams both see the entire coverage area. Any TDMA signal that goes up to the spacecraft is repeated and can be heard by any receiving station. Now consider what would happen if the coverage areas were divided into two or more zones served by individual beams. A TDMA signal transmitted up in one beam could only go down in another if there were some means in the satellite to recognize its intended destination and route it to the transmitters feeding that other beam. If there are thousands—or millions—of individual

signals coming up, the satellite is presented with the tremendous task of reading and routing individual messages—at the clock rate of the TDMA system.

Intelsat VI will be able to recognize signal destination and process signals appropriately for routing and retransmission. Its satellite switched TDMA unit is a 6 by 10 matrix of PIN diodes driven by a digital logic unit. It will route individual TDMA signal components from the six uplink beams to the appropriate ten downlink beams at a clock rate of 944 KHz. A photograph of the engineering model of this SSTDMA unit is shown in Figure 11.

Satellite switching of digital signals will improve rapidly. The next step is to demodulate upcoming signals to digital form using high speed analog-to-digital circuits, then process them for subsequent retransmission in a digital processor. When this onboard digital sorting and distribution of signals is combined with a rapidly scanning antenna beam, the result is a system solution of extraordinary capacity.¹⁹

The prospect of onboard signal processing²⁰ is made possible by the rapid development of analog-to-digital conversion circuitry and compact digital processors. This will probably be the most challenging and exciting area of satellite technology in the next decade. It clearly holds enormous potential for space telecommunications.

19 Bell Laboratories first proposed such a system, using a synchronized flying spot beam and TDMA modulation technique; "Scanning Spot Beam Satellite System," by Douglas O. Reudink and Yu S. Yeh, Bell System Technical Journal, Vol. 56, No. 8, October 1977.

20 To be developed by NASA's ACTS program and others.

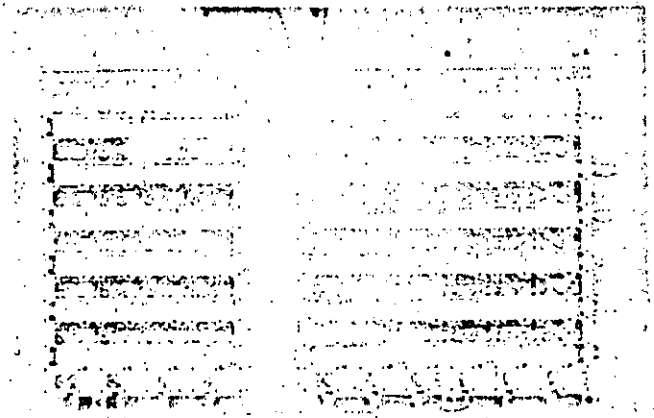


Figure 11. Satellite Switched TDMA Unit for Intelsat VI

LAUNCH VEHICLES

The price of launch vehicles has traditionally represented about half the cost of establishing a communications satellite system. Since powerful economic competition confronts satellite communications,²¹ increasing attention has been focused on the cost of launch services.

Two new launch vehicles—the shuttle and Ariane—were flight tested and committed to operational service in the last 4 years. (See Figure 12.) The American space shuttle first flew into low Earth orbit in 1981, and has been a model of reliability on that and each succeeding flight. After four test flights, it

	1979	1980	1981	1982	1983
SHUTTLE			○ ○	○ ○ ○	○ ○ ○ ○
ARIANE		○ X	○ ○	X	○ ○
				OPERATIONAL	

Figure 12. Ariane and Shuttle Flight Record

21 Unlike government-sponsored programs to visit the planets or survey the earth.

ejected two communications satellites, one Canadian and one American, during its first operational mission in November 1982. It has flown three times more since then, placing the TDRSS, Anik C, Palapa-B, and INSAT 1B in low Earth orbit.

It was anticipated that the shuttle would be very reliable because of the safety demands imposed for the sake of the astronauts.²² This is now reflected in low premiums for launch insurance: 4 to 7 percent for the shuttle versus 5 to 8 percent for Delta and 10 to 14 percent for Ariane.²³ The shuttle pricing policy announced in 1977 offered attractive rates for the first 3 years of operation. NASA has recently announced the pricing policy for the second 3 year period. The progression is shown in Figure 13 for a typical domestic satellite, together with the price history for launching such a spacecraft with the Delta and Ariane. This comparison indicates a con-

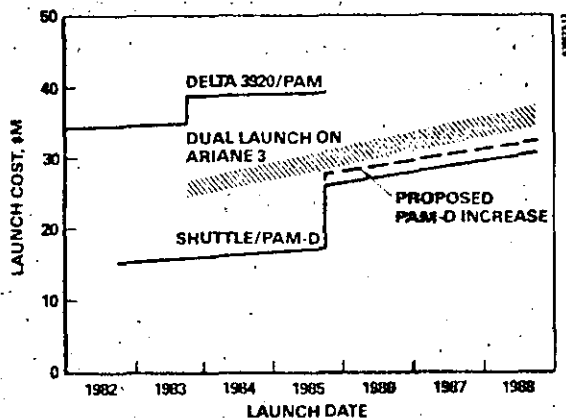


Figure 13. Launch Cost Progression for Delta Class Satellites

22 "The Economics of Telecommunications in the Century of the Satellite," by Albert D. Wheelon, World Telecommunication Forum, Geneva, September 20, 1979.

23 The range of insurance depends on satellite and motor performance and launch record. Presumably, as Ariane achieves more successes, the gap between its rates and those of other proven launch vehicles will narrow.

tinuing price advantage for the shuttle. Some observers complain that the differential is more a reflection of government subsidization than it is a fundamental disparity in launch economics. Whatever the truth, satellite launch costs have taken their first drop in two decades.

The corollary to the increasing use of the shuttle is the rapid decline in the availability of the three American expendable launch vehicles: Delta, Atlas Centaur, and Titan. All have established enviable records of reliability. In the face of the shuttle's operational success and aggressive pricing, however, expendable vehicles have suffered a precipitous decline in orders. This is rapidly driving up unit prices, as fixed costs are spread over fewer and fewer flights. The result is that the production facilities for all three are being phased out this year.

This past spring NASA offered to commercialize Delta, Titan, and Atlas Centaur by allowing private ventures to use government tooling and launch facilities at reasonable rates. Several firms are pursuing this opportunity. However, a bid for Intelsat VI launch services submitted by Titan backers was not cost competitive with the shuttle and Ariane 4. It is my judgment that none of them can compete with the two major government-sponsored programs. It will be surprising if these launch vehicles are available options when next we meet.

The Ariane rocket is the surviving alternative to the shuttle. It first flew almost coincidentally with the shuttle. It experienced two failures in its flight test program, but with the launch of ECS in June 1983, it seems to be fully operational. It represents the only ongoing pressure on shuttle pricing. It also presents an alternative way into space if the shuttle is grounded or becomes overcommitted. A second launch

pad is being built at Kourou, French Guiana, and this will increase confidence in the Ariane alternative. The rocket is also being upgraded—eventually to the Ariane 4 configuration, which could place 4,200-kg in transfer orbit.

To preserve the benefits of price competition and operational convenience, it was specified that Intelsat VI be launchable either by the space shuttle or the Ariane 4. The way it will be carried in the shuttle and Ariane 4 is shown in Figure 14. However, there is an important distinction between Ariane and the shuttle. Ariane puts a satellite into elliptic transfer orbit, from which it rises to synchronous altitude. In contrast, the shuttle places a satellite into low Earth circular orbit at 160 n.mi. Shuttle launching therefore requires either an additional stage to push the satellite into transfer orbit or that the satellite carry adequate propulsion capability to do the job itself.

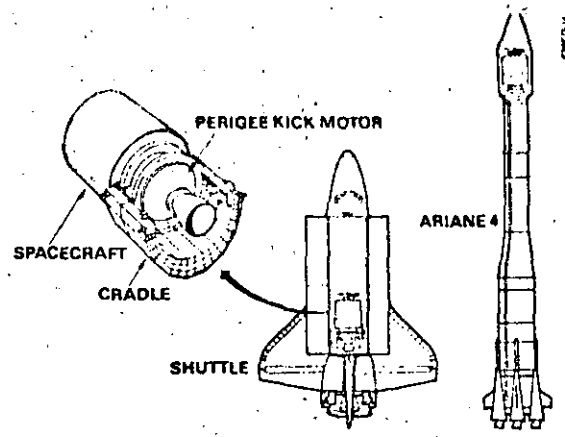


Figure 14. Intelsat VI Shuttle and Ariane 4 Launch Configurations

Two standard upper stages have been developed to place shuttle payloads into transfer orbit. One, the PAM-D, is a commercial venture that provides perigee impulse for Delta class payloads with a solid rocket motor. It has worked perfectly five times on three shuttle flights.²⁴ Its developer has recently proposed a rising price schedule, which, when added to a rising shuttle price, will make the shuttle PAM-D progressively less competitive.

The second standard upper stage is the inertial upper stage (IUS). This was developed by the U.S. Air Force for its own needs and those of NASA. The IUS can place

2,273 kg in geosynchronous orbit; it provides both the perigee and apogee velocity impulses with two solid rocket motors controlled by three redundant guidance systems. IUS has two problems: one transient, the other systemic. During its first operational use in April 1983, it failed to place TDRSS into its intended synchronous orbit. This was caused by a second stage motor nozzle failure, which can be corrected with time and money. The systemic problem is its cost. The original basis for proceeding with IUS was that it would cost several million dollars per shot. That price has now grown to over a hundred million and is still rising. There are no commercial users and there will be none. Even some Air Force programs have abandoned IUS for cost reasons, and NASA has switched its spacecraft to a new high energy upper stage based on Centaur. IUS exemplifies the classic problem of trying to do all jobs with a single machine:

The economic alternative to standard upper stages is spacecraft integral propulsion.²⁵ The concept is to incorporate a solid or liquid rocket motor into the spacecraft design to

24 PAM-D appears to be a successful enterprise. Sixty-seven PAM-D/PAM-D II stages have been ordered, roughly 60 percent for commercial satellites. Most PAM-Ds will be used on the shuttle to lift payloads into high orbits. The remainder are final stages for Delta.

25 Used for the Voyager spacecraft, for example.

provide the perigee impulse—just as communications satellites have always provided their own apogee kick motors. This technique exploits the precision of the shuttle guidance system to establish the correct initial orientation at spacecraft separation. This attitude is preserved gyroscopically by spinning out of the shuttle bay until a safe separation distance is achieved for rocket motor firing. The leverage of this approach is threefold. First, it uses the satellite's own guidance system, rather than investing in redundant inertial platforms as IUS does. Secondly, users buy only the combination of rocket motors needed to place the specific satellite in orbit—instead of the total capability required for all other users of the stage. This minimum investment in integral propulsion contrasts with the highest common denominator implicit in standard upper stages. The third virtue is the elimination of a separate development organization and the network of interface requirements that must be established between the standard upper stage and every potential user.

The economic advantages of integral propulsion are overwhelming in the telecommunications sector, where price competition with alternate means of transmission is central to decision making.

Integral propulsion is being used for Intelsat VI and was the decisive price difference in selecting the developer. It seems to be the chosen path for most of the third generation domestic satellites now being developed.

CONCLUSION

Satellite communications have made significant progress in the past 4 years. Even greater strides will be made in another 4 years as the number and capacity of new satellites increase. However, a variety of economic, technical, and regulatory issues cloud this otherwise optimistic picture. How we cope with these questions will influence the long-term role satellites play in worldwide telecommunications.

ACKNOWLEDGMENT

I would like to express my appreciation to my colleagues at Hughes Space and Communications Group for their counsel and generous assistance in preparing this paper. I am also grateful to friends at Arianespace, Ford, and RCA who were kind enough to review the paper and make helpful suggestions.



**DIVISION DE EDUCACION CONTINUA
FACULTAD DE INGENIERIA U.N.A.M.**

TELECOMUNICACIONES VIA SATELITE

GRAFICAS ADICIONALES

ING. JESUS REYES GARCIA

JUNIO, 1985

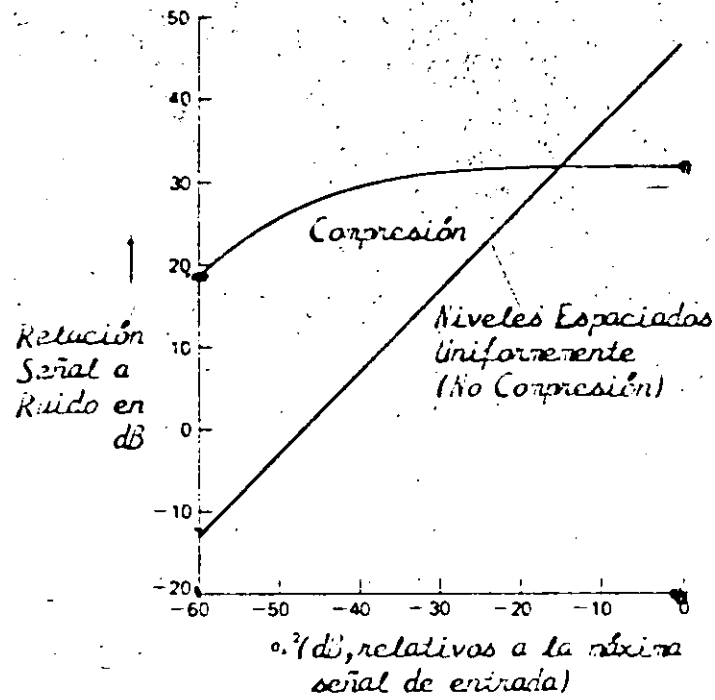
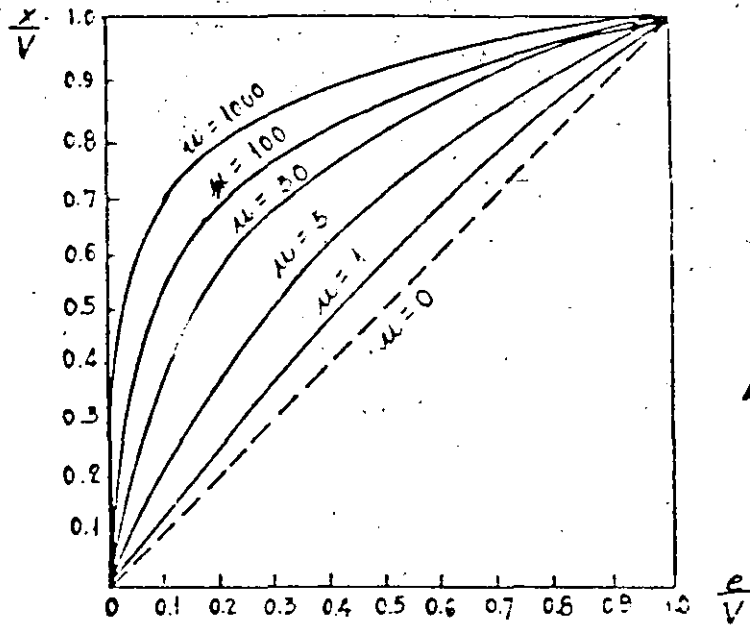


FIGURA N° 11
 Ruido de Cuantificación con Compresión v.s. Potencia de la Señal de Entrada. $\mu = 255$. $M = 128$ niveles.



Ley μ

FIGURA N° 8
Características Logarítmicas de la Compresión.

TABLA I

S/N, dB	M	ancho de banda
11	2	1
17	4	2
23	8	3
29	16	4
35	32	5
41	64	6
47	128	7

Mejoramiento de la Relación Señal a Ruido de Cuantificación con el número de niveles

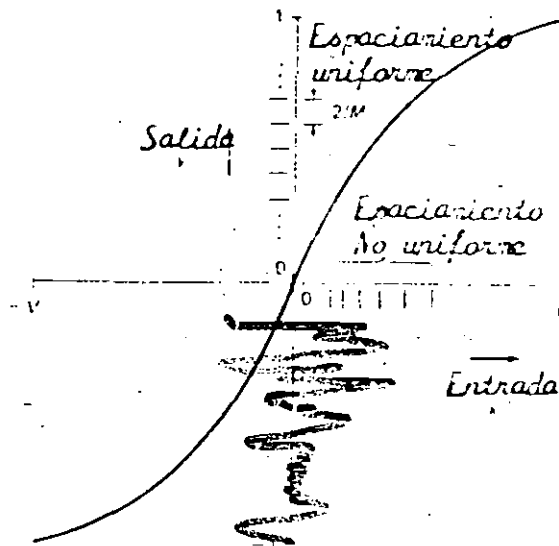
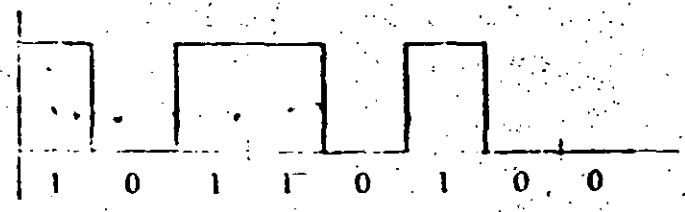


FIGURA Nº 6
Característica del Compresor no Lineal

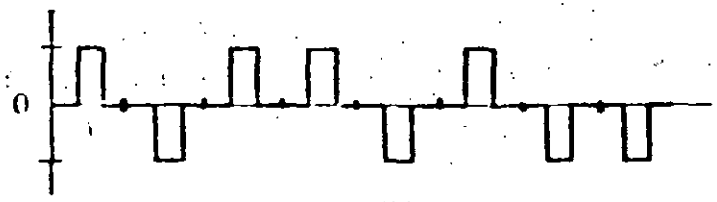


NRZ
unipolar



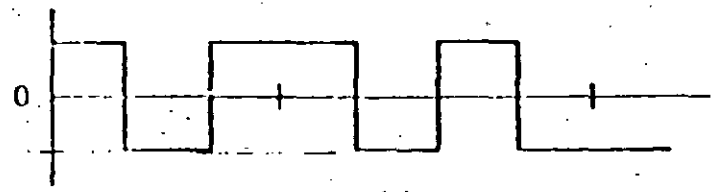
(a)

RZ
Polar



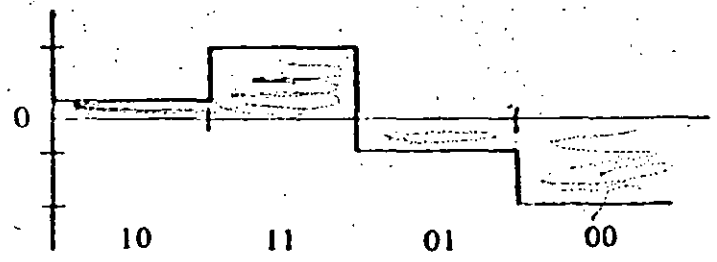
(b)

NRZ
Polar



(c)

Multinivel



(d)

unipolar

1 \rightarrow $+V$
0 \rightarrow 0

Polar

1 \rightarrow $+V$
0 \rightarrow $-V$

Bipolar

1 \rightarrow $+V$ 0 \rightarrow $-V$
0 \rightarrow 0

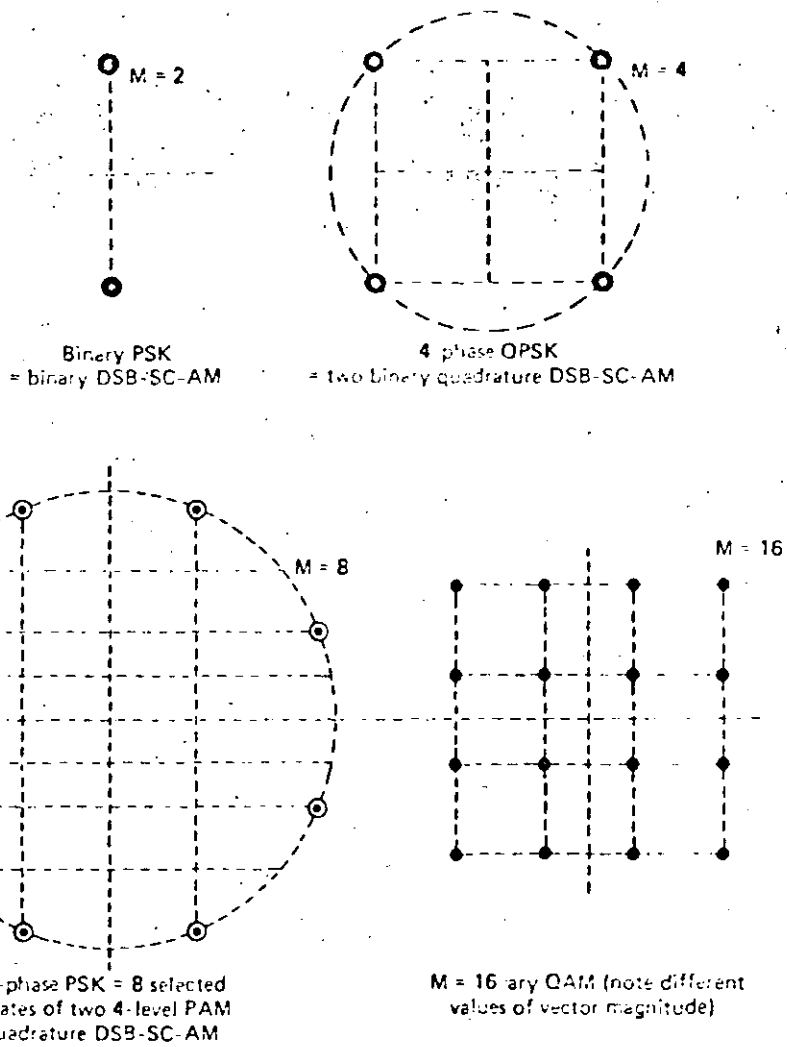


Fig. 6.8. Signal-state space diagrams of M -ary PSK and QAM signals.



**DIVISION DE EDUCACION CONTINUA
FACULTAD DE INGENIERIA U.N.A.M.**

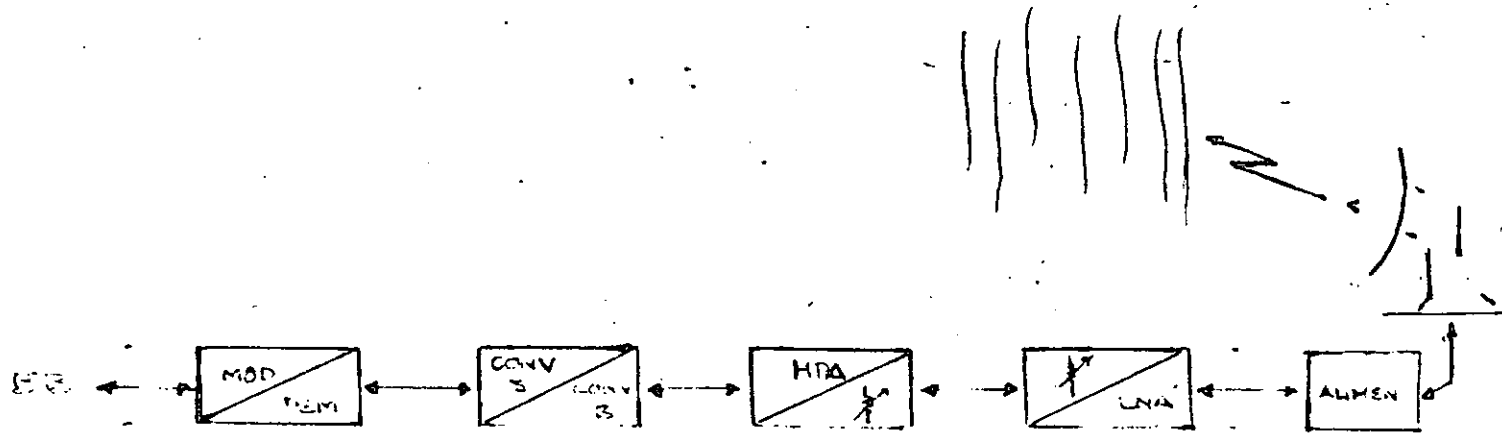
TELECOMUNICACIONES VIA SATELITE

ANEXOS

ING. JORGE LOPEZ SHUNIA

JUNIO, 1985

EFFECTOS DE RADIOPROPAGACION EN LOS ENLACES VIA SATELITE



$$(S/N) = (C/N)_T + E. M. \quad \text{dB}$$

$$(C/No)_T^{-1} = \left[(C/No)_u^{-1} + (C/No)_T^{-1} + (C/No)_D^{-1} \right]$$

$$(C/No) = EIRP + (G/T) + 228.6 - L_s + F - L_g \quad \text{dB} - \text{Hz}^{-1}$$

$$EIRP = S + A_s - L_a \quad \text{dBW}$$

$$L_s = 20 \log(4\pi R \lambda^{-1})$$

$$A_s = 10 \log(4\pi R \frac{c}{\lambda})$$

$S \triangleq$ densidad de flujo

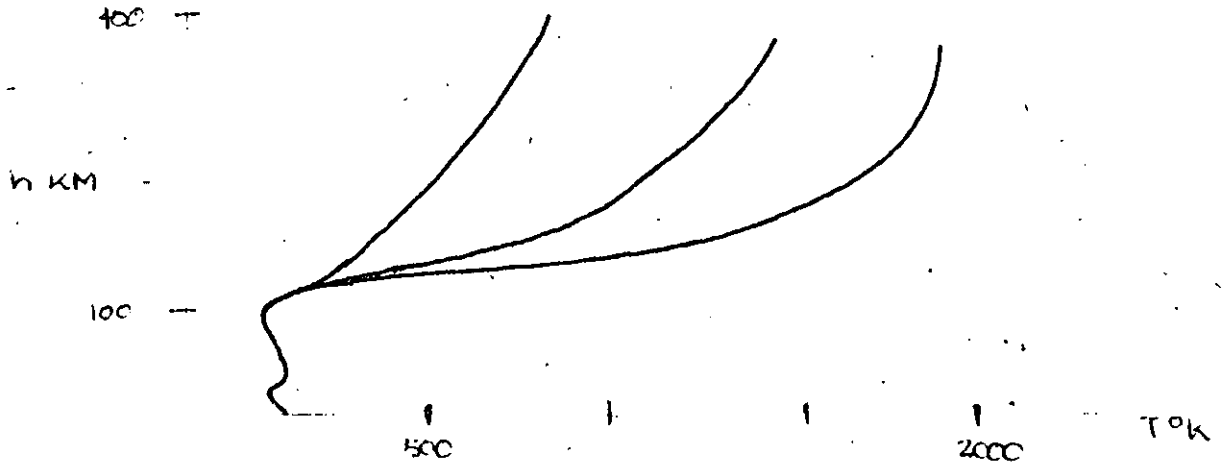
$A_s \triangleq$ atenuación por dispersión

$F \triangleq$ margen de desvanecimiento

ATMOSFERA

Troposfera		$h \leq 16$	Km
Estratosfera	$T \propto h$,	$16 \leq h < 50$	Km
Mesosfera	$T \propto h^{-1}$	$50 < h \leq 85$	} Km Ionosfera
Termosfera	$T \propto h$	$85 < h$	

En la troposfera se desarrollan casi todos los fenómenos meteorológicos



- (a) Atmosfera nocturna
- (b) Atmosfera promedio
- (c) Atmosfera diurna

VHF : Interferencia vía ionosfera y las diferentes

UHF : Capas que la forman E, F₁, F₂.

SHF : Pérdidas por difracción y dispersión, relativa atenuación por precipitación en la base de la banda, pero importante en la media y alta.

EHF : Atenuación y absorción muy severas.

PROPAGACION EN LA TROPOSFERA

El índice de refracción de la troposfera para las OEM esta en función de la temperatura, presión, y contenido de vapor de agua

$$N = f(T, P, e)$$

T \triangleq Temperatura

P \triangleq Presión

e \triangleq Vapor de agua

Smith y Weintraub encontraron la siguiente relación matemática, que expresa la refractividad atmosférica

$$N = 77.6 pT^{-1} + 3.73 e (10^5 T^{-2})$$

ó

$$N = 77.6 T^{-1} [p + 4810eT^{-1}]$$

Nótese que existe una dependencia muy alta en e que es la presión del vapor de agua

La variación de la refractividad en la troposfera ocasiona un patrón de refractividad que influencia sobre la OEM, este patrón varía según el medio geográfico y con el tiempo.

La medición de la refractividad se efectúa por medio de refractómetros, detectando diferencias de la refractividad, en condiciones típicas cercanas a tierra se tiene:

$$\delta N = 0.27 \delta P - 1.7 \delta T + 4.5 \delta e$$

47

La variación de la refractividad en la atmosfera ocasiona que las OEM no se propaguen en la línea recta, para un medio estratificado esfericamente, la refractividad se -- puede expresar

$$n(h) (h+a) \cos \alpha (h) = k$$

Donde $\alpha (h)$ es el angulo de doblez con respecto a la horizontal. Esta demostrado que para un gradiente vertical en refractividad dn/dh , la onda se refracta hacia la región de mayor refractividad con un radio de curvatura

$$r^{-1} = -n^{-1} (dn/dh) \cos \alpha$$

Entonces

$$k = r_e r^{-1} = (1+r_e \left(\frac{dn}{dh} \right) 10^{-6})^{-1}$$

Ya que la temperatura varía con la altura, así también la refractividad en la troposfera, aproximadamente por

$$N(h) = N_s \exp(-h/h_0)$$

Dónde N_s es la refractividad de la superficie y h_0 es la altura escalar

El gradiente promedio de refractividad en el primer kilómetro de altura es dado por

$$\Delta N = N(1) - N_s$$

Donde ΔN es negativo por gran parte del tiempo

CCIR define una atmosfera promedio como aquella donde $N_s = 315$ y $\Delta N = -40$

$$N(h) = 315 \exp(-h/7.36)$$

Varios estudios han demostrado que

$$\Delta N = -A \exp(BN_s)$$

Donde $2.1 < A < 9.3$ y $0.0045 < B < 0.0094$

Según el clima

Considerando la figura 1, se tiene lo siguiente

Región de Ducting	Región de Super Refracción	Región de Sub Refracción
$dN/dh < -157$	$-157 < dN/dh < -40$	$-40 < dN/dh$
$k < 0$	$0 < k < 1/3$	$1/3 < k < 0$
$r_e < 0$	$0 < r_e$	$0 < r_e$

Quando el gradiente de refractividad en los límites de dos masas de aire es suficientemente abrupto comparado con la longitud de onda, este puede causar reflexión parcial de la energía.

Ducting es de menor importancia a frecuencias menores de 500 MHz, mientras que reflexión lo es para frecuencias mayores a 1 GHz.

Quando existen variaciones pequeñas en refractividad debido a cambios locales de humedad y/o temperatura, si estas variaciones son suficientes en intensidad, esto causará dispersión de energía, esto ocasionará centelleo de la OEM que pase por esta región.

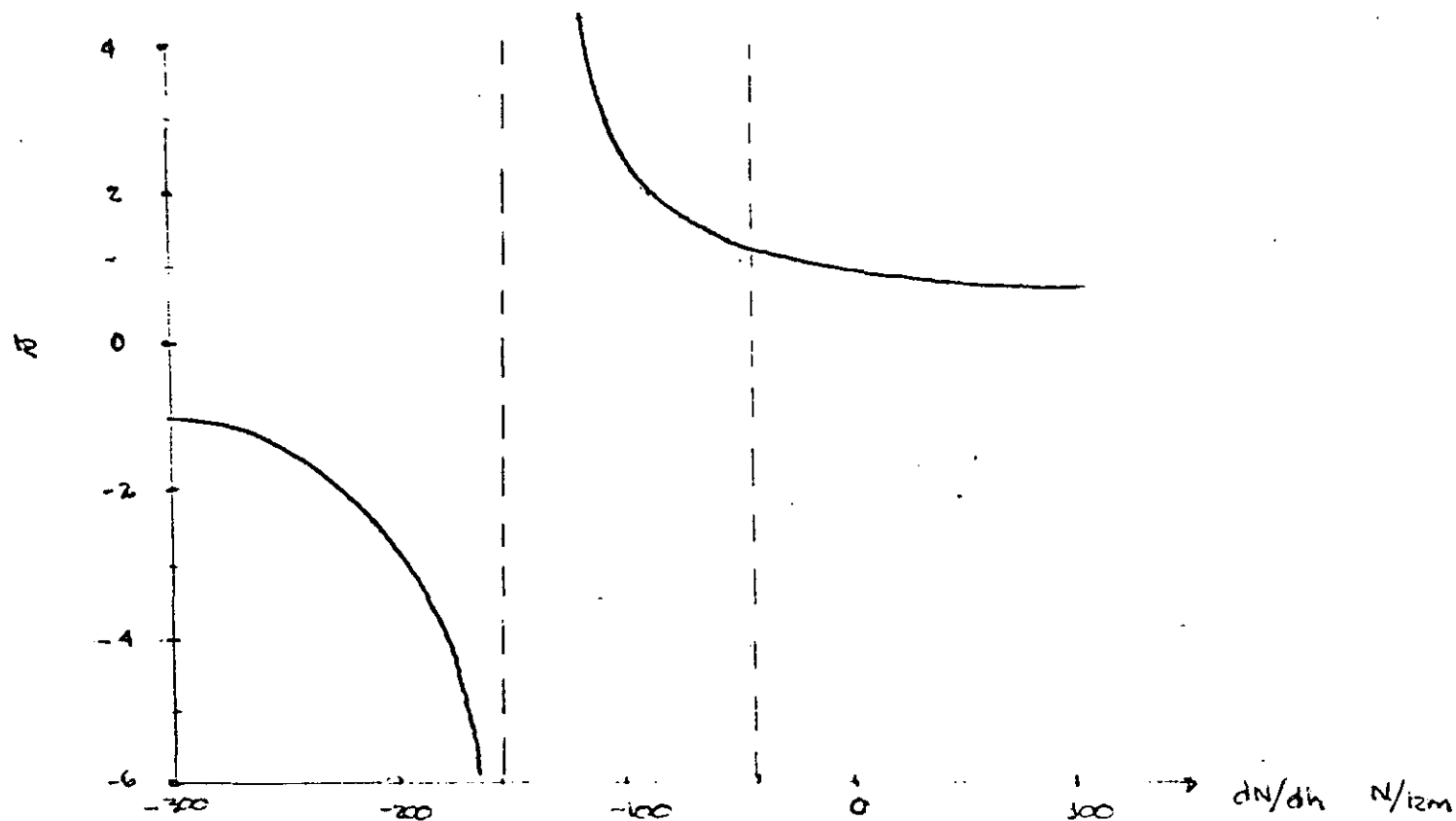
El centelleo es causado por fluctuaciones en la refractividad producidas por pequeñas variaciones en el enfoque de la línea de vista del haz. Así la señal recibida es la suma de la gran cantidad de componentes que arriban de diferentes direcciones con cambios continuos en amplitud, de tal manera que la resultante tiene variaciones aleatorias tanto en amplitud y fase, ocasionando así desacoplamiento entre el medio y la antena. Esta pérdida de acoplamiento decrece con el ángulo de elevación, aumenta con la frecuencia.

Centelleo troposferico es dificil de producir un desvanecimiento severo en los enlaces vía satélite que operan con ángulos superiores a 10° y frecuencias menores próximas a 10 GHz.

Estudios experimentales en centelleo troposférico indican que la desviación estándar de la potencia recibida como función del ángulo de elevación α entre 3 y 20° , es

$$\sigma = 6.5 \alpha^{-1.5}$$

Para frecuencias entre 2 y 10 GHz y antenas con diámetros entre 20 y 40 M.



PROPAGACION IONOSFERICA

La ionosfera es un medio ionizado en una región con altura entre 60 y 500 Km o más incluyendo la parte más baja de termosfera. La región es ionizada por la radiación solar en el rango de frecuencias entre el ultravioleta y los rayos X. Este plasma contiene electrones libres e iones positivos haciéndola eléctricamente neutra, con una sola fracción con moléculas ionizadas.

Las regiones con mayor dinámica son la E y F, en la región D esto es significativo al alborada. Al propagarse la OEM en estas regiones, una fuerza proporcional a la intensidad del campo eléctrico se ejerce en las partículas cargadas. El movimiento resultante de las partículas cargadas genera una corriente y esta modifica ciertas características de la OEM. La región E está entre 90 y 140 KM con una concentración aproximada de 10^5 e/cm³, tiene alta conductividad eléctrica. Induciendo efectos geomagnéticos muy apreciables. Las ondas en la banda HF (3 -30 MHz) se reflejan en esta región, pudiéndose emplear para COM'S, la región F se subdivide en F₁ y F₂, F₂ es altamente utilizable en COM'S.

En COM'S vía satélite, la confiabilidad del enlace puede verse limitada por absorción ionosférica, normalmente esto decrece al aumentar la frecuencia y puede ser ignorado a frecuencias superiores a 70 MHz en regiones ecuatoriales y templadas.

Centelleo ionosférico de amplitud, fase, polarización y ángulo de arribo, puede limitar el enlace en frecuencias no mayores a 6 GHz especialmente en latitudes ecuatoriales y boreales. Centelleo

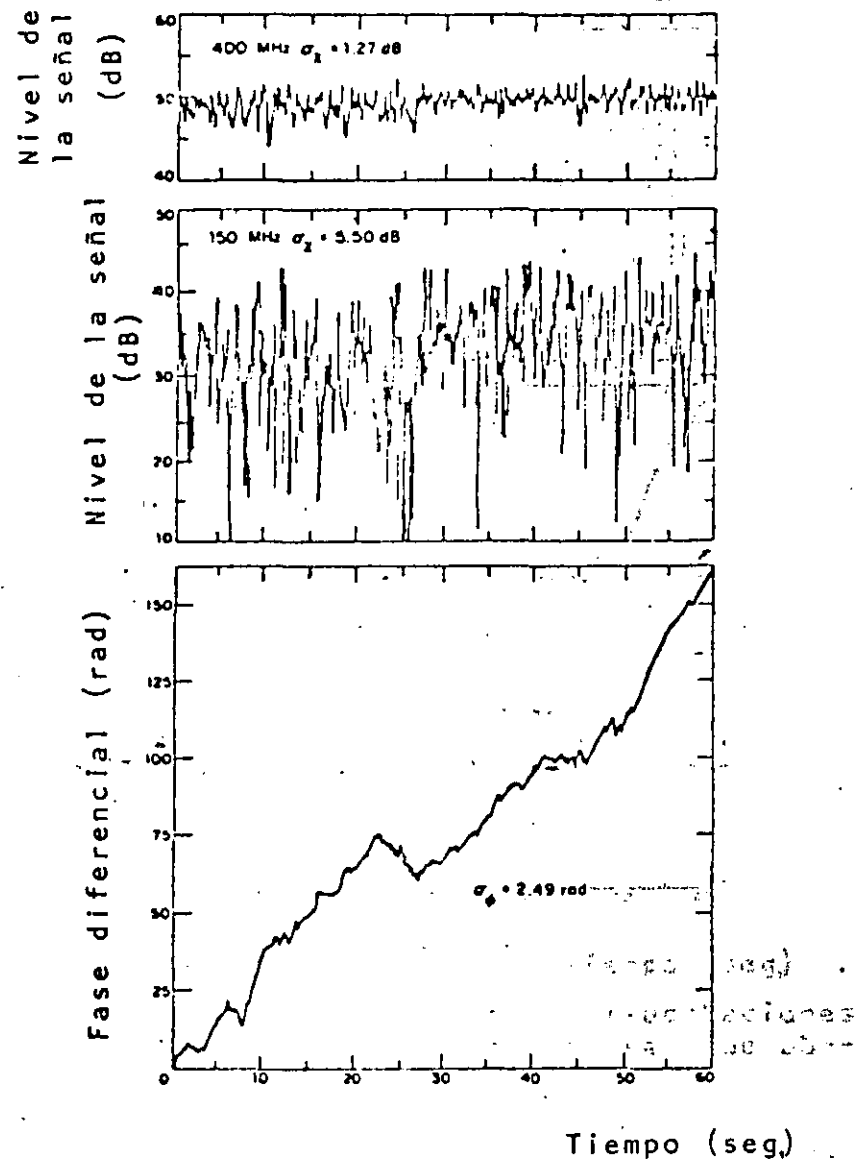


Fig. 29 Nivel de la señal y fluctuaciones de fase para un intervalo de observación de 1 min.

debido a perturbaciones en las regiones E y F se presenta a frecuencias superiores a 100 MHz con magnitudes de cierta importancia (3 - 10 dB).

Diversos estudios demuestran que los efectos mayores se aprecian en frecuencias alrededor de 136 MHz, en COM'S vía satélite se aprecia cuando los ángulos de elevación son menores a 10°.

Como se mencionó anteriormente, la ionosfera es una región de la atmosfera ionizada, o sea un plasma, si a este se le aplica un campo magnético y se propagan en el medio dos OEM características, estas son polarizadas circularmente. Una OEM lineal no es una OEM característica por lo que su polarización cambia cuando ésta se propaga, pero en ausencia de pérdidas ésta permanece sin cambio.

Debido a pérdidas la dirección del vector de intensidad rota, a esta rotación se le conoce como rotación de Faraday, que constituye un cambio de polarización. La rotación total está dada por

$$\theta = 2.36 (10^4) f^{-2} \int NB dz$$

N \triangleq refractividad

B \triangleq campo magnético

f \triangleq frecuencia

DISPERSION Y ABSORCION POR PARTICULAS Y GASES

Dispersión de la OEM es un proceso de re-radiación de la energía de la OEM incidente. La re-radiación tiene un patrón muy amplio y por lo tanto cierta energía es radiada fuera -- del haz. Dispersión causa atenuación, en esto no se ve involucrado el proceso de conversión de la energía electromagnética a otra forma, mientras que absorción se refiere a la disipación o conversión de la energía electromagnética a energía térmica.

Dispersión y absorción se llevan a cabo simultáneamente en general, pero una y otra predominan.

Dispersión y absorción causan atenuación, el resultado combinado se denomina extinción:

$$\text{Extinción} \triangleq \text{Dispersión} + \text{Absorción}$$

Este concepto se aplica a secciones transversales, coeficiente de atenuación, profundidad óptica, etc. así:

$$\alpha_{\text{ext}} \triangleq \alpha_d + \alpha_a$$

Donde α es el coeficiente de atenuación. La integral del coeficiente de atenuación con respecto a la longitud se conoce como profundidad óptica, indicada como :

$$\tau_{\text{ext}} \approx \tau_d + \tau_a$$

Nótese que el coeficiente de atenuación es coeficiente de atenuación en potencia.

La lluvia, nieve y granizo pueden ocasionar fuerte atenuación de las ondas milimétricas y ópticas, la lluvia puede causar problemas a frecuencias desde 1400 MHz, éstos problemas se intensifican a mayores frecuencias hasta 150 GHz al menos, transmisiones de ondas milimétricas a través de la lluvia se ven afectadas seriamente.

El coeficiente por atenuación de potencia de la lluvia está dado por

$$d = \int_a n(a, x, t) C_{\text{ext}}(n_c, a/\lambda) da$$

Donde a es el radio de la gota, la función $n(a, x, t)$ es el número de gotas con un radio entre $(a+da)$ en función del tiempo y distancia. C_{ext} es la función de extinción en la -- sección transversal tomando en cuenta absorción y dispersión, n_c es el índice de refracción de la gota.

En la práctica se utiliza la distribución empírica de Laws and Parsons, dando muy buenos resultados.

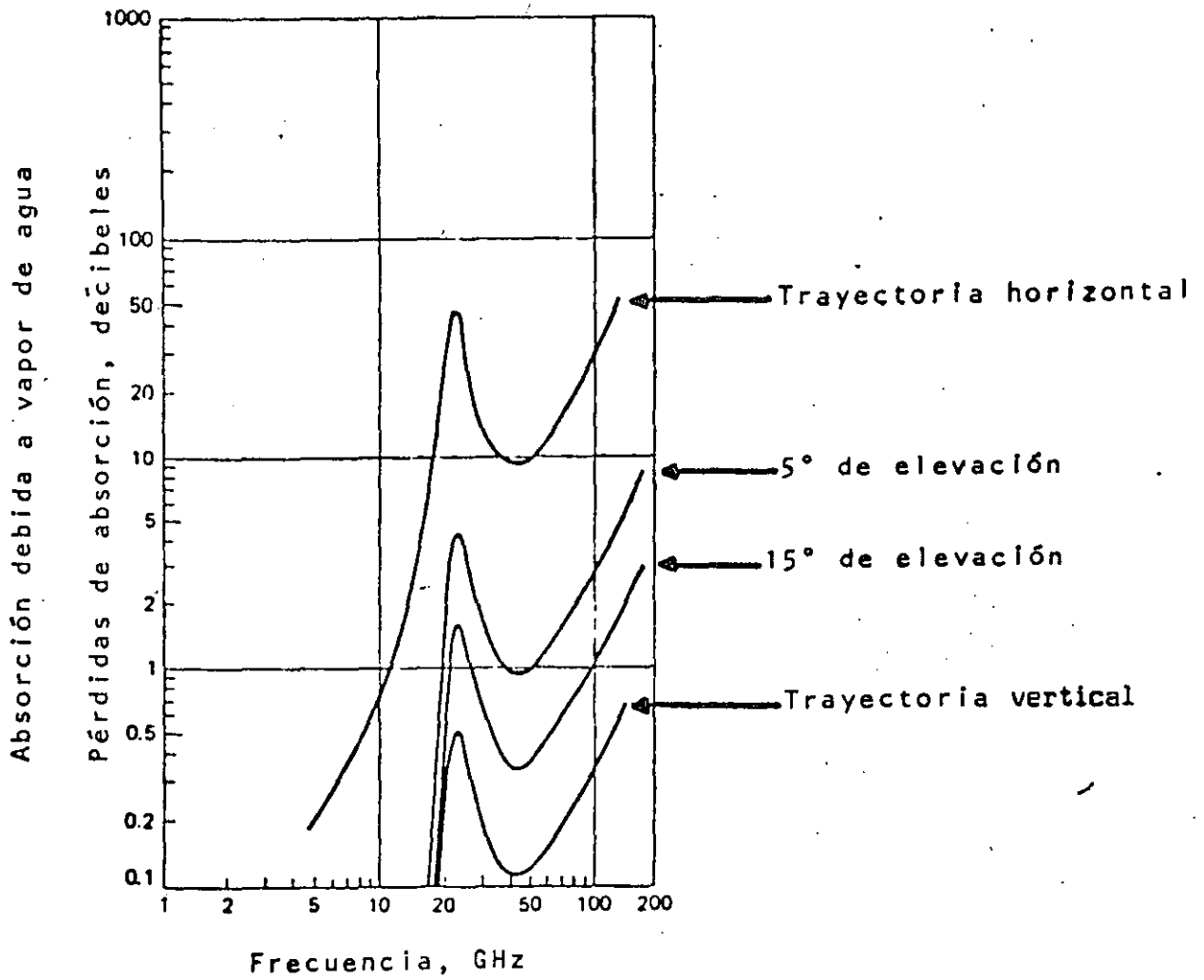
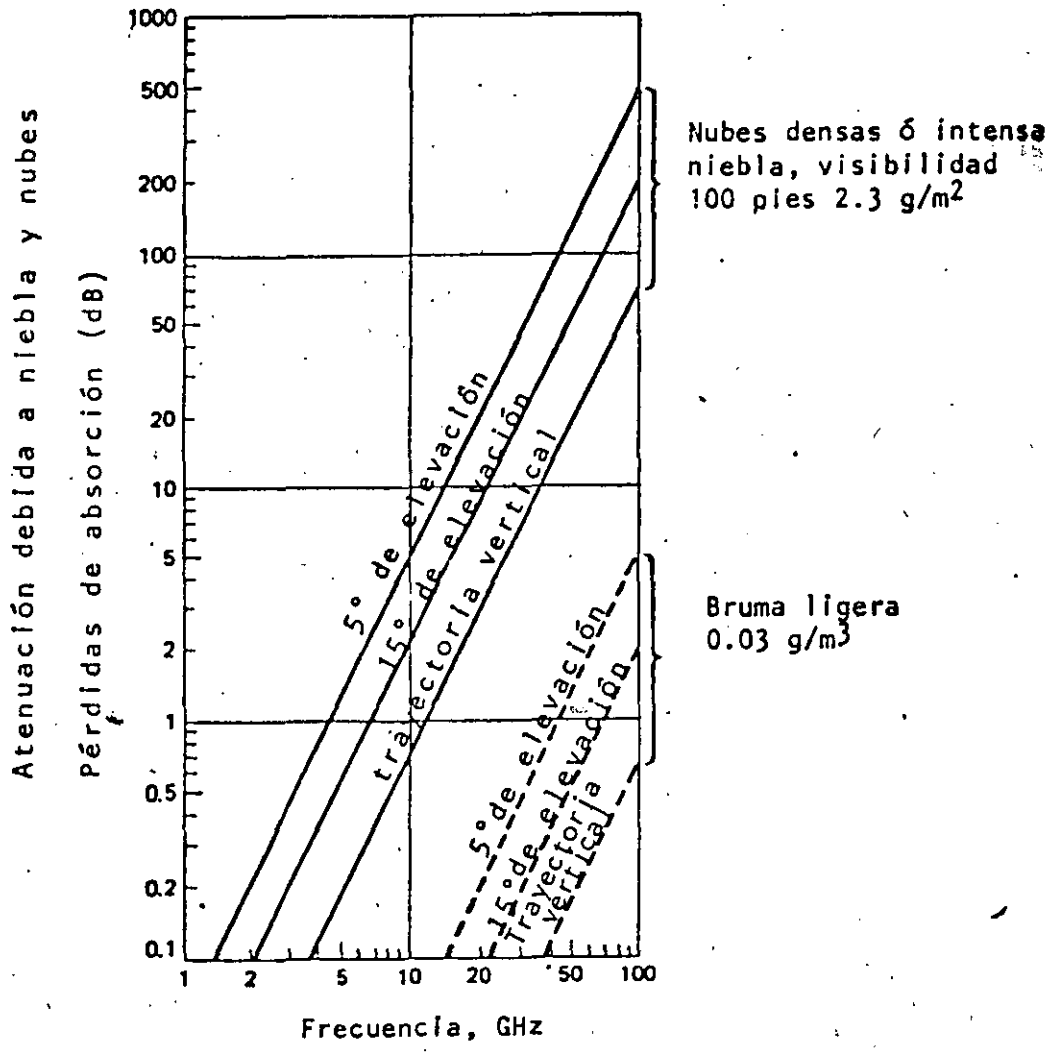


Fig. 30 Absorción en la atmósfera causada por vapor de agua sin condensar.



Típica absorción debida a niebla, bruma y nubes.

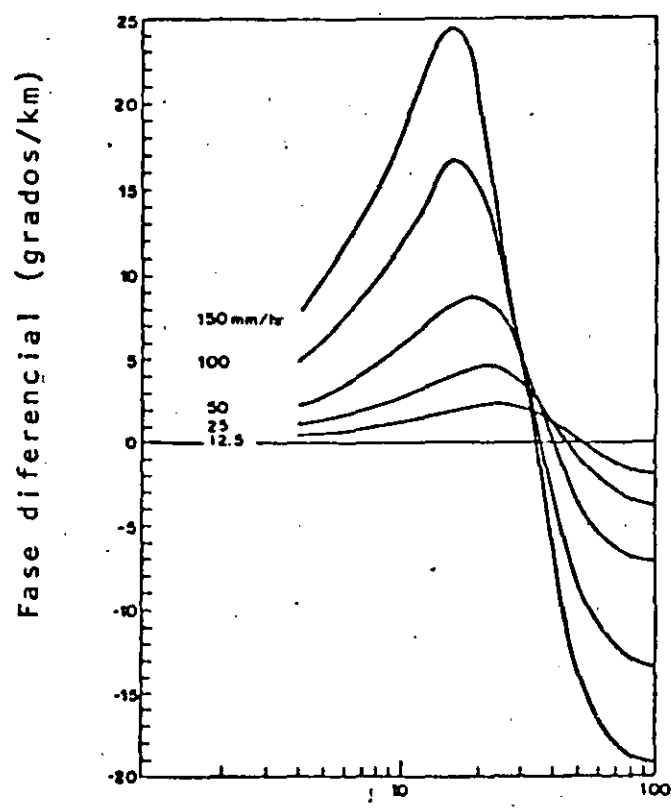
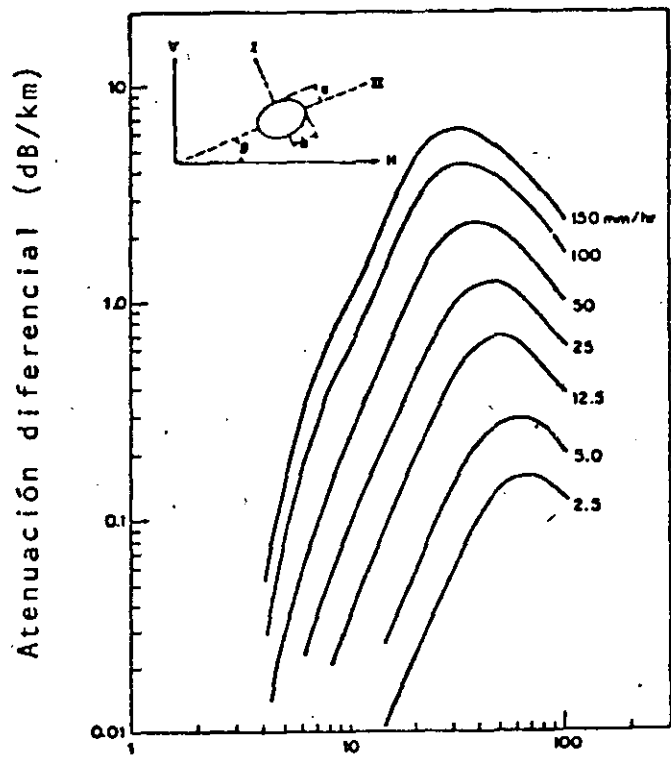


Fig. 34 Atenuación y fase diferencial entre polarizaciones I y II para varias intensidades de precipitación.

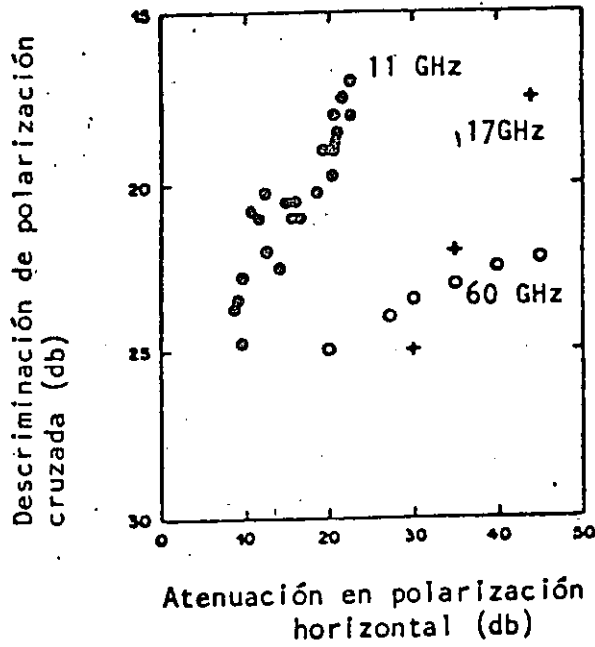


Fig. 35 Polarización cruzada Inducida por lluvia para polarización horizontal.

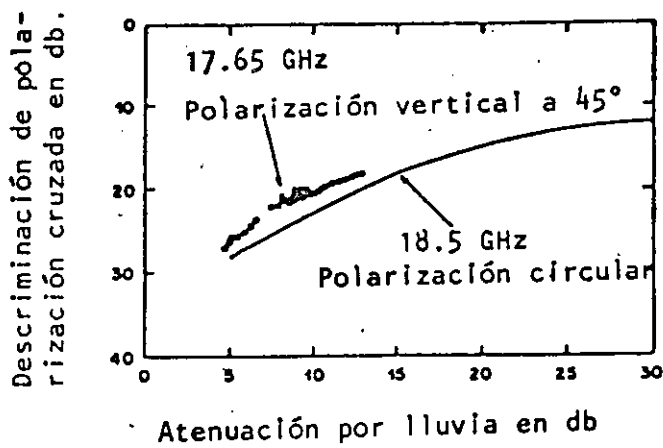
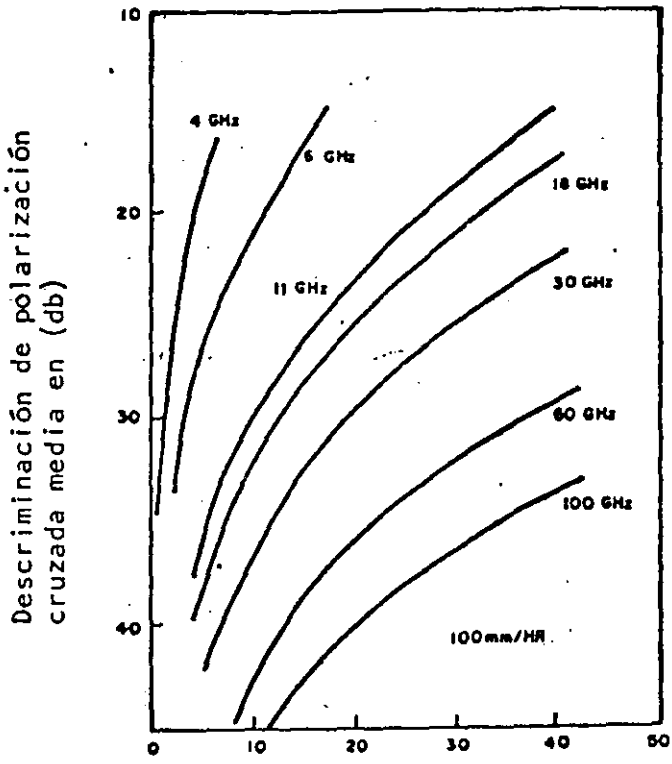


Fig. 36 Depolarización medida contra atenuación para polarización circular y polarización lineal a 45°.



Atenuación en polarización horizontal en dB.

Fig. 37

La determinación de la función C_{ext} en su caso general se basa en la teoría de dispersión por MIE.

Para longitudes de onda mayores al radio de las gotas (Banda SHF), atenuación por absorción es predominante para longitudes de onda menores al radio de las gotas (banda EHF) la dispersión es predominante en la atenuación.

En las telecomunicaciones vía satélite, el grado de confiabilidad en los enlaces se ve afectado primordialmente por las condiciones meteorológicas y climáticas en períodos de tiempo mayor.

Por lo que es necesario contar con métodos de predicción para determinar la confiabilidad en los enlaces, así como el margen de operación del sistema como un todo, por lo que el diseño de los enlaces en un medio adverso es primordial.

La atenuación es el resultado de la dispersión y/o absorción de energía por los hidrometeoros, dependiendo del estado físico de ellos, número, tamaño, distribución de orientación, propiedades dieléctricas, y distribución espacial. Para la determinación de la ocurrencia probabilística de esta atenuación, las propiedades mencionadas deben ser consideradas estadísticamente.

Desde el punto de vista físico, el medio atmosférico es un lugar donde se llevan a cabo -- fenómenos físicos donde variables como: temperatura, presión, altura, concentración de -- humedad, energía interna, entalpia, y entropía, conforman el medio, y los eventos son el resultado de la dinámica terrestre. Por lo tanto, las características de los hidrometros son influenciadas por las variables antes mencionadas en el estudio estadístico de los -- eventos meteorológicos, estas variables deben considerarse para posteriormente poder conformar un modelo específico.

Otro fenomeno a considerar en el estudio estadístico es la depolarización que es inducida por la presencia de hidrometeoros como gotas de lluvia y cristales de hielo causando trayectorias múltiples de las OEM. Este efecto es de importancia a frecuencias mayores a -- 6 GHz.

La evaluación de extinción y de polarización requiere entonces de un modelo predictivo, -- que nos dará los mágenes de atenuación por precipitación, y depolarización por la presencia de los hidrometeoros.

Actualmente existen diferentes técnicas de predicción para determinadas condiciones de operación e hidrometeorológicas. Entre los modelos más confiables están

Modelo de Rice-Homberg

Dutton-Daugherty

S. H. Lin

Modelo Global de R.K. Crane

Cada modelo presenta ciertos parámetros que los hacen distintos entre ellos, y dependiendo de las variables disponibles se puede seleccionar el que más se adapte a las -- circunstancias específicas de cada región o zona.

Los tres primeros modelos mencionados, únicamente tienen como variable la intensidad de precipitación como factor representativo del medio atmosférico, sin embargo ésta variable está en función de las variables físicas del medio, por lo que deben ser consideradas en los modelos predictivos.

R. K. Crane desarrolla un modelo predictivo en términos globales en su aplicación, que puede ser aplicado a cualquier región, considerando su medio geofísico. Este está influenciado por los eventos meteorológicos y éstos a su vez conforman el clima específico para esa región geográfica.

Las variables que se consideran en forma directa son:

Intensidad de precipitación

Altitud del lugar

Temperatura

Presión atmosférica

Altitud de la isoterma de 0°C.

Con la finalidad de obtener alta confiabilidad en el resultado predictivo, las estadísticas de temperatura, presión, intensidad de precipitación y altitud de isoterma, deberán ser al menos de 25 a 35 años de observaciones.

La tabla siguiente muestra los diferentes márgenes de precipitación con diferentes grados de disponibilidad anual, en siete regiones hidrometeorológicas del país.

Estos resultados se aplican únicamente para los enlaces en banda Ku, ya que para banda C, los efectos por precipitación son negligibles hasta para intensidades de 100mm/h al 99.99% anual.

ZONA GEOGRAFICA	CONFIABILIDAD				
	99.99	99.98	99.95	99.90	99.80%
NOR OCCIDENTE	8.4	7.0	5.1	3.4	3.2
NORTE CENTRO	5.6	4.3	2.3	2.0	1.9
GOLFO NORTE	12.8	11.5	9.5	7.8	7.6
CENTRO	9.7	8.3	6.4	4.7	4.5
PACIFICO CENTRO	11.1	9.7	7.8	6.1	5.9
ITSMO	11.1	9.8	7.8	6.1	5.9
YUCATAN	10.4	9.0	7.1	5.4	5.2

40

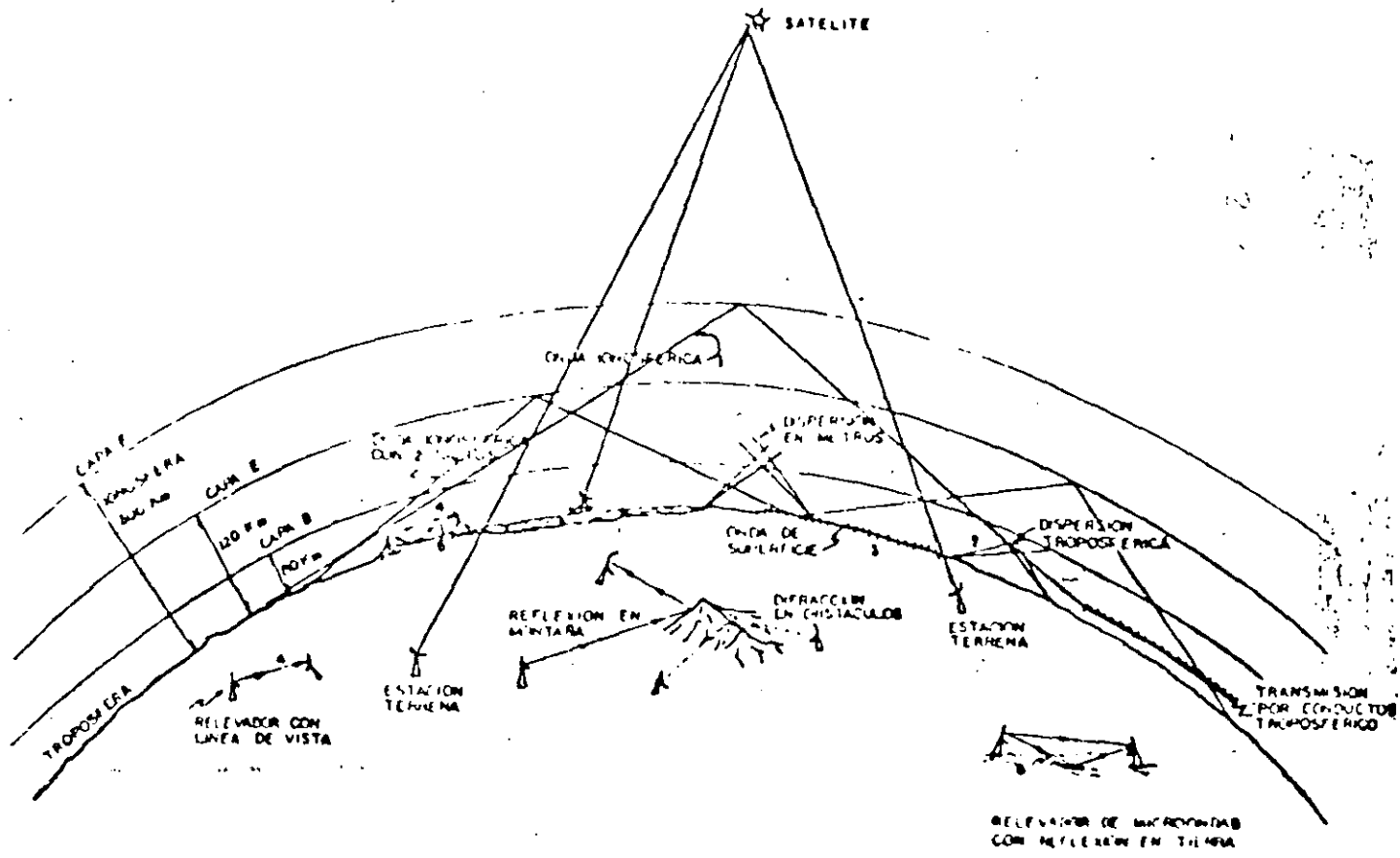


FIG. 4-1 TRAYECTORIAS DE PROPAGACION

A 4/6-GHz Link.

Satellite Antenna: Earth Coverage.
Earth Antenna: 12 meters.

Moderately Low-Cost Electronics in Earth Station.

A 12/14-GHz Link.

Satellite Antenna: 1.8 Meters.
Earth Antenna: 1.8 Meters.

Low-Cost Earth-Station Receiver.

A 20/30-GHz Link for Common Carrier Use.

Satellite Antenna: 2 Meters.
Earth Antenna: 27.5 Meters.

Cryogenically Cooled Receiver.

A 12/14-GHz Link on a Broadcast Satellite.

Satellite Antenna: 9 Meters.
Earth Antenna: 1.8 Meter Receiver-only; 12-Meter Transmitter.

Low-Cost Earth Station.

Up-Link

Transmitter power, dBw*	35	25	20	20
Transmitter system loss, decibels	-1	-1	-1	-1
Transmitting antenna gain, decibels	55	46	76	62
Atmospheric loss, decibels	0	-0.5	-2	-0.5
Free space loss, decibels	-200	-208	-214	-208
Receiving antenna gain, decibels	20	46	53	60
Receiver system loss, decibels	-1	-1	-1	-1
Received power, dBw*	-92	-93.5	-69	-68.5
Noise temperature, °K	1000	1000	1000	1000
Received bandwidth, MHz	36	36	350	36
Noise, dBw*	-128	-128	-118	-128
Received SNR, decibels	36	34.5	49	59.5
Loss in bad storm, decibels	2	10	25	10
Received SNR in bad storm, decibels	34	24.5	24	49.5

Down-link

Transmitter power, dBw*	18	20	8	10
Transmitter system loss, decibels	-1	-1	-1	-1
Transmitting antenna gain, decibels	16	44	49	58
Free space loss, decibels	-197	-206	-210	-206
Atmospheric loss, decibels	0	-0.6	-2	-0.6
Receiver antenna gain, decibels	51	44	72	44
Receiver system loss, decibels	-1	-1	-1	-1
Received power, dBw*	-114	-100.6	-85	-96.6
Noise temperature, °K	250	1000	250	1000
Received bandwidth, MHz	36	36	350	36
Noise, dBw*	-131	-128	-121	-128
Received SNR, decibels	17	27.4	36	31.4
Loss in bad storm, decibels	2	10	25	10
Received SNR in bad storm, decibels	15	17.4	11	21.4

*dBw means decibels referenced to one watt. I. E. 1 watt = 0 dBw; 100 watts = 2 dBw, etc.

VENTAJAS DE FRECUENCIAS MENORES A 10 GHz

- MENOR ABSORCION ATMOSFERICA.
- MENOR RUIDO.
- SE TIENE UNA TECNOLOGIA BIEN DESARROLLADA.
- MENOR ATENUACION.

DESVENTAJAS DE FRECUENCIAS MENORES A 10 GHz

- LAS BANDAS SON COMPARTIDAS CON SERVICIOS TERRESTRES.
- CONGESTIONAMIENTO DE LA ORBITA.

VENTAJAS DE FRECUENCIAS MAYORES A 10 GHz

- MENOR INTERFERENCIA.
- SE PUEDEN COMPARTIR CON SERVICIOS TERRESTRES.
- FACILIDAD EN LA ORBITA.

DESVENTAJAS DE FRECUENCIAS MAYORES A 10 GHz

- MAYOR ATENUACION.
- MAYORES EFECTOS POR LLUVIA Y GASES ATMOSFERICOS.

Densidad de Ruido.

El término densidad de ruido se refiere al ruido por Hertz de ancho de banda:

$$\text{densidad de ruido} = \frac{P_r}{B} = KT$$

Relación Portadora a Ruido.

Una relación frecuentemente usada para establecer la calidad de un satélite es:

$$\frac{\text{Potencia de la portadora recibida}}{\text{densidad de ruido}} = \frac{P_R}{KT}$$

La potencia de la portadora se simboliza frecuentemente con C. La anterior relación $\frac{C}{N}$ es llamada la relación señal a ruido. En la Fig. 39 se grafica la relación $\frac{C}{N}$ contra el EIRP para un enlace de subida de un típico satélite doméstico Norte-Americano. Se puede ver que dicha relación no puede ser mejorada hasta algún cierto nivel debido a que se alcanza una saturación en el canal.

Fuentes externas de ruido.

Las siguientes son fuentes externas de ruido: El sol, la luna, la tierra, ruido galáctico, ruido cósmico, ruido del cielo, ruido atmosférico y ruido hecho por el hombre. Estas fuentes difieren en su intensidad, frecuencias y localización en el espacio.

Si la antena de un satélite apunta hacia el sol, la señal será prácticamente contaminada debido a la temperatura de ruido del sol que es de 100,000°k ó más.

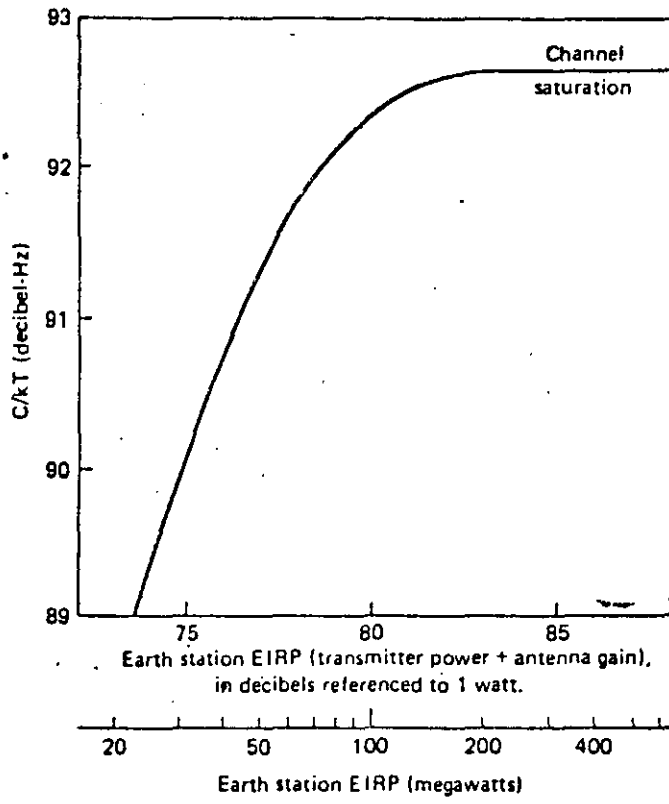


Figure 7.1 C/kT for a typical American domestic satellite.

Fig. 39

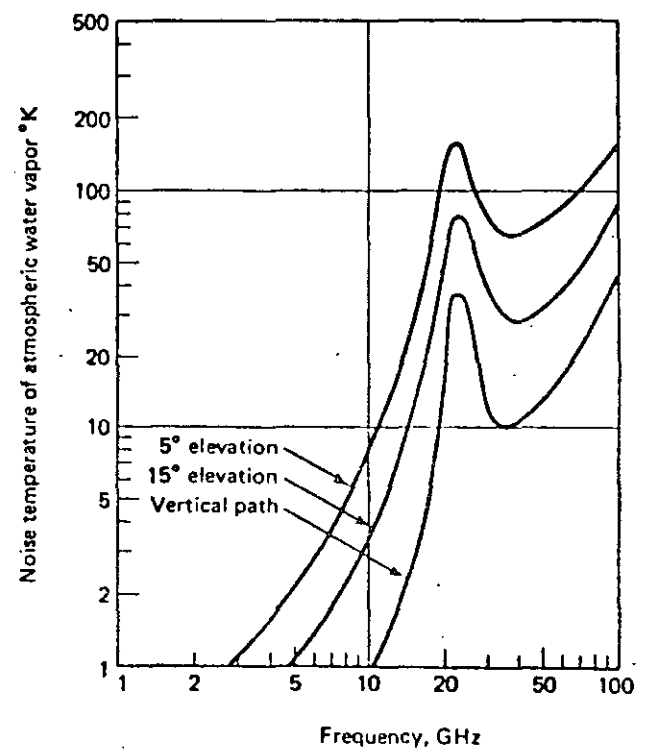
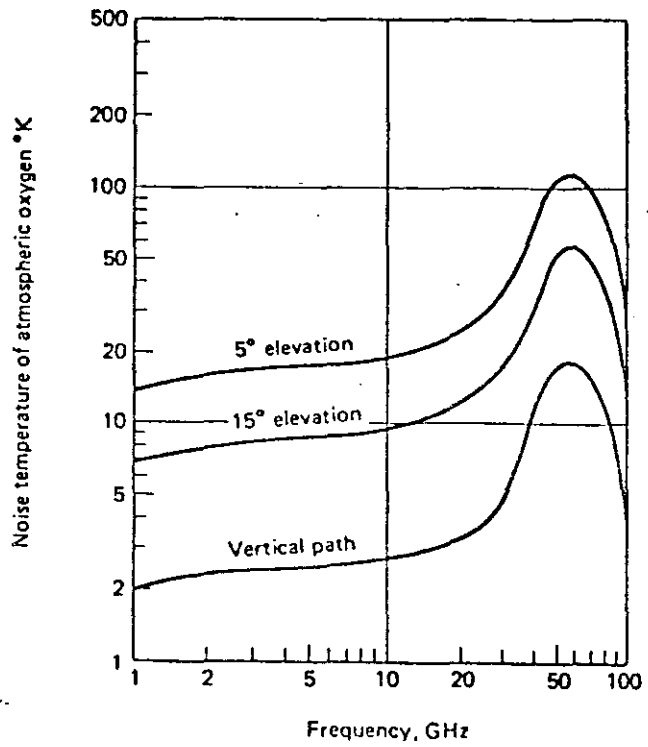


Fig. 40

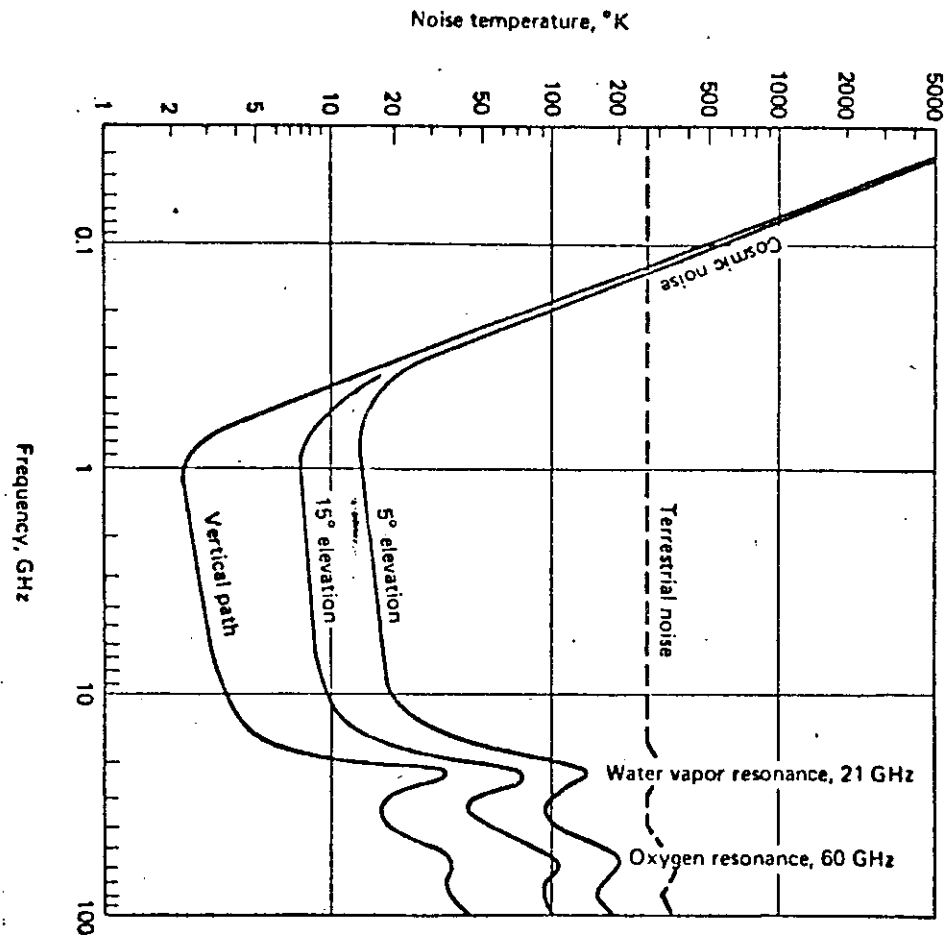


Fig. 41

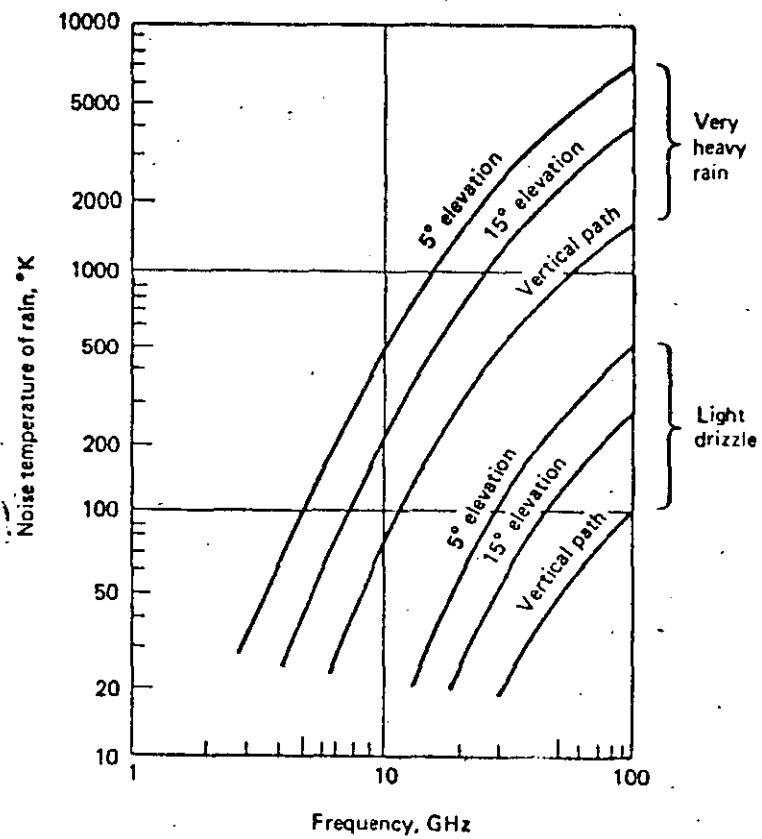
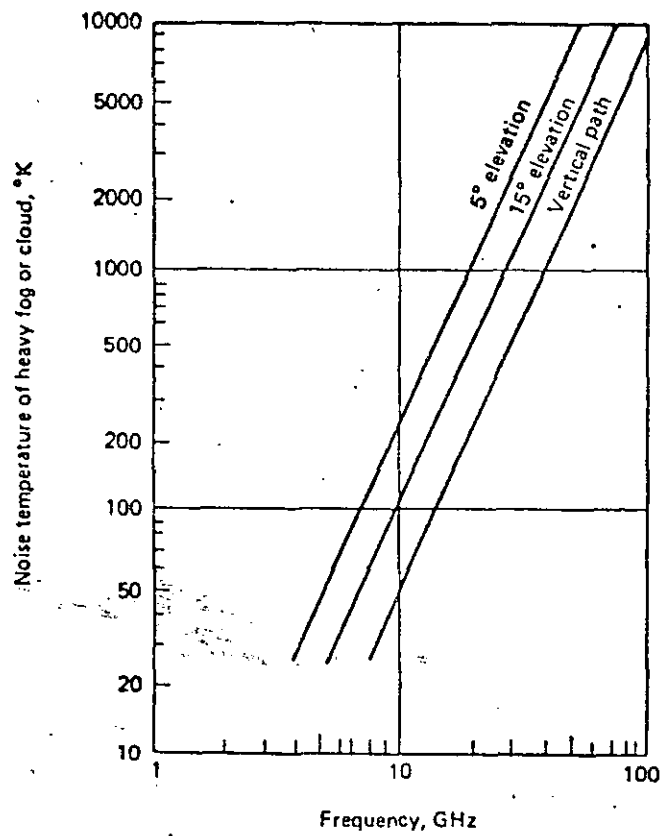


Fig. 42

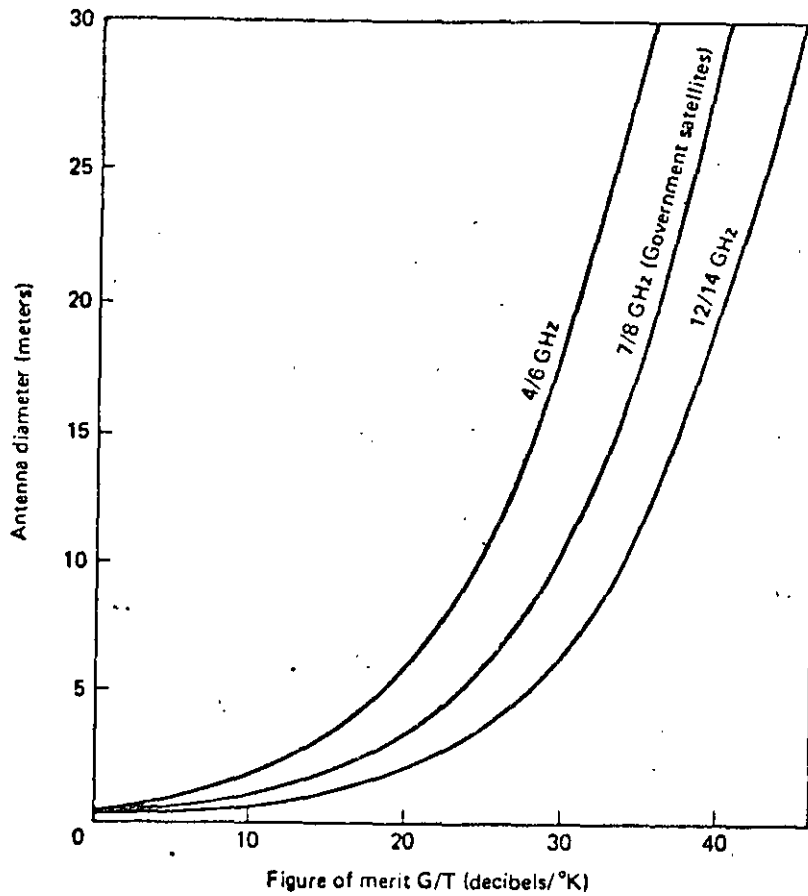


Fig. 44

Table 7.1 Noise figures for typical types of receiver equipment and typical resulting signal-to-noise ratios.

Type of Electronics	Noise Temperature of Electronics	Typical Noise Temperature of Antenna	Combined Noise Temperature of Antenna & Electronics	S/N for a Received Signal of 10 picowatts (10^{-11} watts)
Maser (cooled to 4.2°K)	10	60	70	14.6 decibels
Parametric amplifier (cooled to 25°K)	35	60	95	13.3 decibels
Uncooled parametric amplifier	120	60	180	10.5 decibels
Inexpensive parametric amplifier	300	60	360	7.5 decibels
Tunnel diode amplifier	530	60	590	5.3 decibels
Schottky mixer	1000	60	1060	2.7 decibels

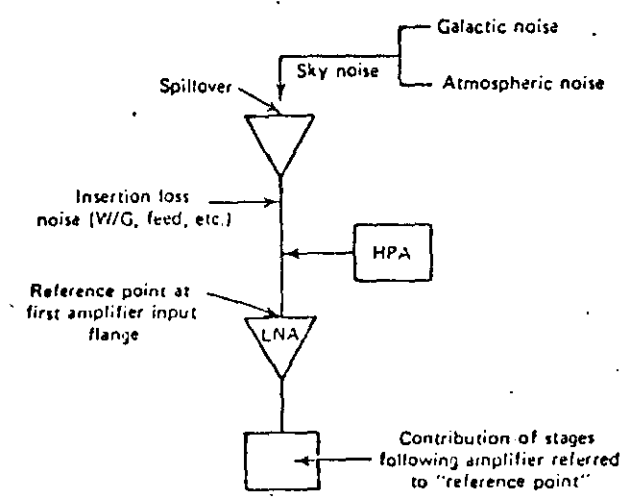
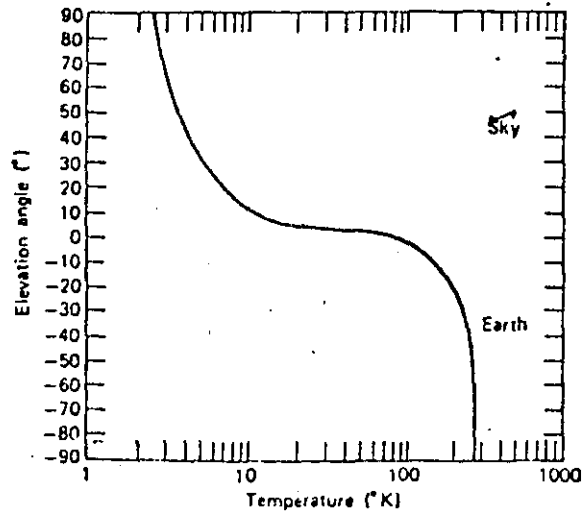


Figure 7.5 Graphical representation of noise contributors. HPA = high-power amplifier; LNA = low-noise amplifier.

Fig. 45



Approximate sky noise variation with antenna elevation angle (4 GHz).

Fig. 46

223:

223210 OF THE PROCEEDINGS OF THE INSTITUTE OF ELECTRICAL AND ELECTRONICS ENGINEERS
 WASHINGTON, D.C. 20541

ELECTRONIC ENGINEERING AND COMMUNICATIONS
 WASHINGTON, D.C. 20541



**DIVISION DE EDUCACION CONTINUA
FACULTAD DE INGENIERIA U.N.A.M.**

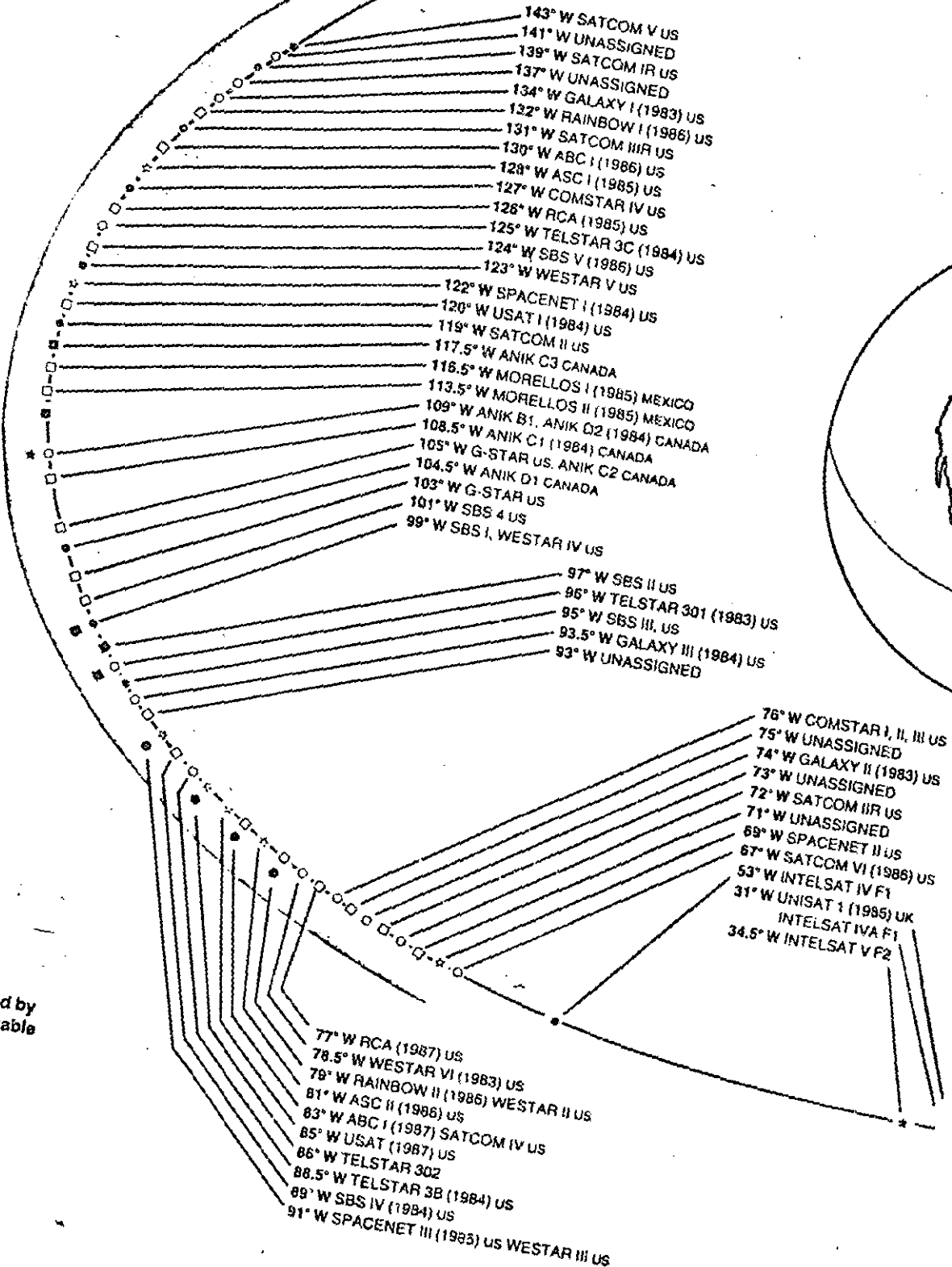
TELECOMUNICACIONES VIA SATELITE

ANEXOS

JUNIO, 1985

Worldwide Geosynchronous Satellites

AUSSAT I (1985) AUSTRALIA 156° E
 AUSSAT II (1986) AUSTRALIA 160° E
 AUSSAT III (1986) AUSTRALIA 164° E
 INTELSAT IVA F6 175° E
 INTELSAT IVA F3 179° E



Those satellites indicated by the shaded area are viewable from North America.

135° E SAKURA A1 (1983) JAPAN
 130° E SAKURA B2 (1983) JAPAN

BAND	C	K	BOTH
EXISTING	●	■	☆
PROPOSED	○	□	☆

PALAPA B3 (1985) INDONESIA 118° E
 BSE-2, BS-2A (1984) 110° E
 BS-2B (1985) JAPAN
 PALAPA B1 (1983) INDONESIA 108° E
 ISCOM INDIA 105° E

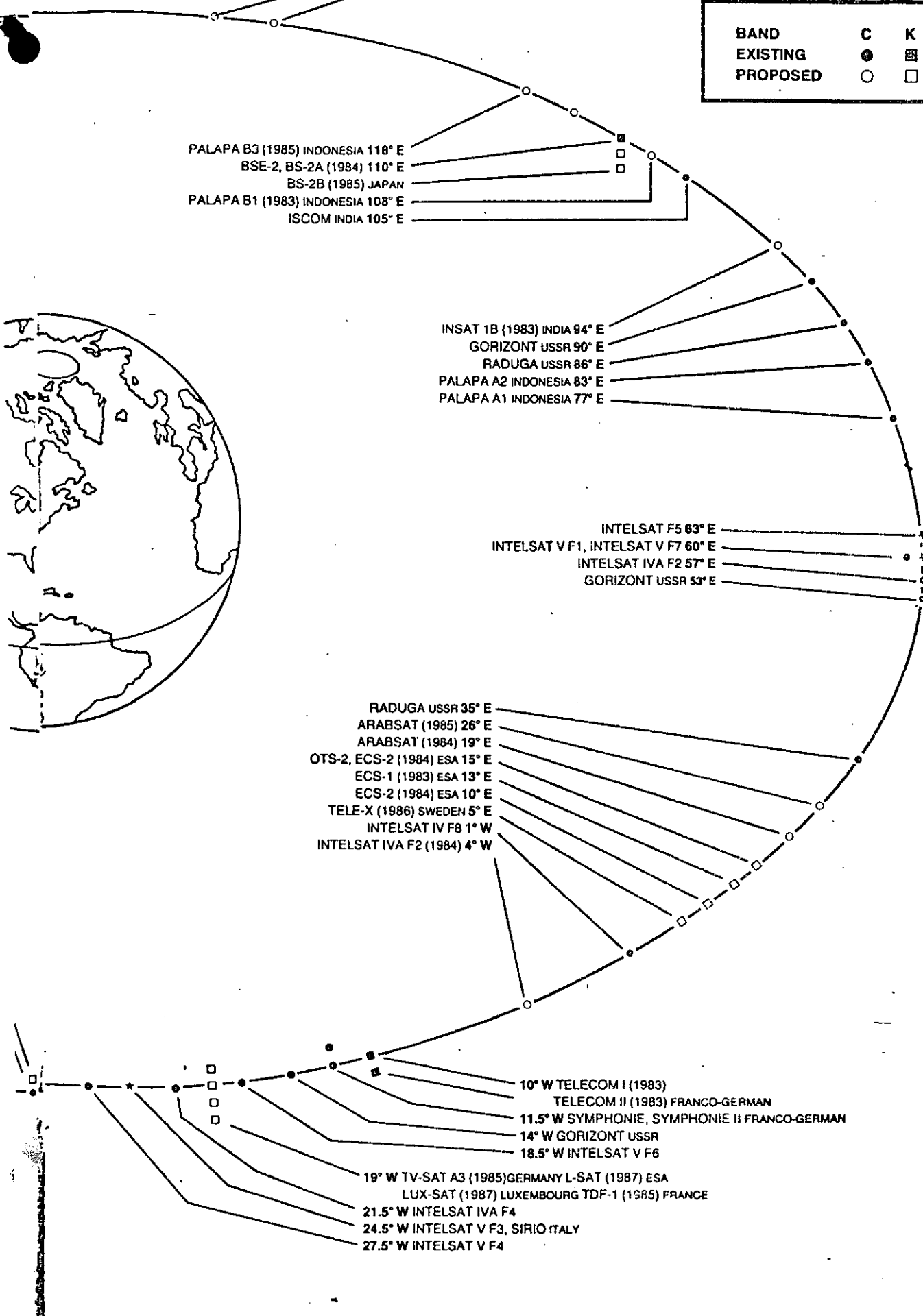
INSAT 1B (1983) INDIA 94° E
 GORIZONT USSR 90° E
 RADUGA USSR 86° E
 PALAPA A2 INDONESIA 83° E
 PALAPA A1 INDONESIA 77° E

INTELSAT F5 63° E
 INTELSAT V F1, INTELSAT V F7 60° E
 INTELSAT IVA F2 57° E
 GORIZONT USSR 53° E

RADUGA USSR 35° E
 ARABSAT (1985) 26° E
 ARABSAT (1984) 19° E
 OTS-2, ECS-2 (1984) ESA 15° E
 ECS-1 (1983) ESA 13° E
 ECS-2 (1984) ESA 10° E
 TELE-X (1986) SWEDEN 5° E
 INTELSAT IV F8 1° W
 INTELSAT IVA F2 (1984) 4° W

10° W TELECOM I (1983)
 TELECOM II (1983) FRANCO-GERMAN
 11.5° W SYMPHONIE, SYMPHONIE II FRANCO-GERMAN
 14° W GORIZONT USSR
 18.5° W INTELSAT V F6

19° W TV-SAT A3 (1985)GERMANY L-SAT (1987) ESA
 LUX-SAT (1987) LUXEMBOURG TDF-1 (1985) FRANCE
 21.5° W INTELSAT IVA F4
 24.5° W INTELSAT V F3, SIRIO ITALY
 27.5° W INTELSAT V F4



DIRECTORIO DE ALUMNOS DEL CURSO "TELECOMUNICACIONES VIA
SATELITE: TEORIA Y APLICACIONES" IMPARTIDO EN ESTA DIVI-
SION DEL 17 AL 28 DE JUNIO DEL PRESENTE AÑO.

- 1.- AGUIRRE ROJAS GERARDO
FACULTAD DE INGENIERIA
PROFESOR LAB. AYUDANTE
AV. UNIVERSIDAD
525-40-20
MAURITANIA No. 14
COL. LOMAS ESTRELLA
DELEGACION IXTAPALAPA
09890 MEXICO, D.F.
582-61-76
- 2.- ALARCON GOLIS PRIMITIVO
PEMEX
SUPERVISOR
DOM. CONOCIDO
CD. DEL CARMEN CAMPECHE
FERROCARRIL No. 16
RD. GABINO BARRERA VERACRUZ
801-43
- 3.- ALVAREZ MARTINEZ RAUL
CIA. MEXICANA DE AVIACION
JEFE DE DEPTO. RADIO COMUNICAC.
AV. 602 No. 161-A
COL. SAN JUAN DE ARAGON
DELEGACION GUSTAVO A. MADERO
762-23-17
NARDOS No. 13
JARDINES DE COYOACAN
DELEGACION COYOACAN
04890 MEXICO, D.F.
684-12-63
- 4.- ARELLANO CHAVEZ AIDA
CALLE SAN JERONIMO No. 355
CONTRERAS
10200 MEXICO, D.F.
595-13-83
- 5.- BETANCOURT BRAVO GERARDO ANTONIO
S. C.T.
JEFE DESARROLLO TECNOLOGICO
AV. INDUSTRIAS ESQ. EJE SANOP
COL. ZONA INDUSTRIAL
SAN LUIS POTOSI, S.L.P.
78800
491-49
CARLOS DIEZ GUTIERREZ No. 1120
COL. BARRIO SAN MIGUELITO
78330 SAN LUIS POTOSI, S.L.P.
- 6.- CARRILLO ROJAS CARLOS GUSTAVO
UNIVERSIDAD AUTONOMA ZACATECAS
MAESTRO DE TIEMPO COMPLETO
LOPEZ VELARDE S/N
ZACATECAS, ZAC.
208-27
FRESNOS No. 117
LAS ARBOLEDAS
- 7.- CARDO ROMERO JULIO CESAR
S. C.T.

- 8.- CARDENAS MUNOZ JAVIER
S. C. T,
TECNICO EN TELECOMUNIC.
IXTAPALAPA
692-00-77 ext. 280 y 287
- 9.- COVARRUBIAS OLIVARES OSCAR
BANCO INTERNACIONAL
ING. TELECOMUNICACIONES
AV. 16 DE SEPTIEMBRE No. 400
GUADALAJARA, JAL.
14-28-70 ext. 282
- 10.- GUAPIO AZTATZI JUAN
UNAM ENEP ARAGON
ACADEMICO
AV. CENTRAL RANCHO SECO S/N
COL. IMPULSORA
NETZAHUALCOYOTL
- 11.- DAMIAN SILVA OSCAR
DIREC. GRAL. ING. DE SISTEMAS
JEFE DE PROYECTO
AV. MICHOACAN S/N
TEPALCATES IZTAPALAPA
- 12.- DANGLADA ALARCON FREDDY
PETROLEOS MEXICANOS
MARINA NACIONAL No. 329
COL. ANAHUAC
254-41-34
- 13.- DIAZ ARRONIZ ROBERTO
S. C.T.
ANALISTA PROGRAMADOR
AV. LAZARO CARDENAS No. 657
COL. NARVARTE
DELEGACION BENITO JUAREZ
530-60-09
- 14.- DOMINGUEZ ROCHA ANDRES
RADIO MOVIL DIPSA
RIO PANUCO No. 55-50. PISO
COL. CUAUHTEMOC
DELEGACION CUAUHTEMOC
06500 MEXICO, D.F.
535-54-38
- 15.- ESPINO RIVERA JULIO
TELEFONOS DE MEXICO
COORDINADOR DEL CENTRO CAPAC.
CLAVERIA No. 180 OF. 104
- 16.- ESTRADA ESTRADA PABLO
- CALLE RELOX No. 370
COL. MODELO
DELEGACION NEZAHUALCOYOTL
57530 MEXICO, D.F
- ISLA PALMIRA No. 2244
GUADALAJARA, JAL.
44930
- ENSENADA No. 10
COL. JARDINES DE CASA NUEVA
55430 ECATEPEC MEXICO
755-67-03
- ROMANA No. 47 EL OLIVO II
TLALNEPANTLA EDO. DE MEXICO
691-77-93
- SIERRA PARACAIMA No. 48
EDO. DE MEXICO
875-26-30
- OJO DE AGUSTIN DELGADO No. 11
EDIFICIO A-703
COL. TRANSITO
DELEGACION CUAUHTEMOC
06820 MEXICO, D.F.
522-64-09
- 20 DE NOVIEMBRE No. 91-B
CENTRO
DELEGACION CUAUHTEMOC
06090 MEXICO, D.F.
512-81-22
- EDIF. 82 ENT. F DEPTO. 402
UNIDAD LINDAVISTA VELLEJO
567-23-81
- MARTIRES DE LA CONQUISTA No. 59
DELEGACION MIGUEL HIDALGO
11870 MEXICO, D.F.
515-70-50

- 17.- ESPINOSA MAYA ALFONSO
UNAM ENEP ARAGON
CATEDRATICO
NEZA, EDO. DE MEXICO
CIO. RIO SN PEDRO No. 58-A
IZTAPALAPA
09010 MEXICO, D.F.
222-10-63
- 18.- ESTRADA MATA MAXIMINO
S. S. A.
ASESOR TECNICO DE MANTO.
DR. BALMIS Y AV. CUAUHTEMOC
COL. DOCTORES
578-42-25
JARICO No. 46
COL. ROMERO RUBIO
DELEGACION VENUSTIANO CARRANZA
789-50-62
- 19.- FIGUEROA JIMENEZ GUILLERMO L.
FUNDACION CULTURAL GUILLE, A.E.
PRESIDENTE ASOCIACION
ANDRINOS No. 124
VILLA DE LAS FLORES
COACALCO 55700
874-34-36
ANDRINOS No. 124
VILLA DE LAS FLORES
55700 COACALCO, MEXICO
- 20.- FRANCO ZERTUCHE VALDEMAR
BANCO INTERNACIONAL
JEFE DE DEPARTAMENTO
PASEO DE LA REFORMA No. 156
5o. PISO
COL. JUAREZ
DELEGACION CUAUHTEMOC
566-00-25
EDIF. I RAMIREZ No. 210-C
UNIDAD NONOALCO TLATELOLCO
DELEGACION CUAUHTEMOC
06900 MEXICO, D.F.
- 21.- GALVEZ GARCIA JESUS
S. C. T.
- 22.- GARCIA OSCOY J. MARIO
PROCESOS Y SIST. DE INFORMAC.
INGENIERO DE SERVICIO
MINERIA No. 145
DELEGACION MIGUEL HIDALGO
JJ800 MEXICO, D.F.
516-04-60
CADENA No. 109
COL. METROPOLITANA
765-31-97
- 23.- GONZALEZ MAICON CASTIMIRO
PETROLEOS MEXICANOS
COORDINADOR CONSTRUC. COSTA
FUERA
GRUPO ZONA MARINA
CD. DEL CARMEN CAMPECHE
COL. EMPLEADOS MOTIZ No. 21
ORIZABA, VER. 94300
- 24.- GORDIANO LARES FLAVIO ANTONIO
S. C. T.
JEFE DE SECCION
AV. TELECOMUNICACIONES S/N
COL. EJIDO DEL MORAL
DELEGACION IZTAPALAPA
692-00-77 ext. 280
C. TRIGO No. 211
COL. VALLE DEL SUR
DELEGACION IXTAPALAPA
09810 MEXICO, DF.
- 25.- GUERRERO PEGUERO SERGIO
HOSPITAL GRAL. DE MEXICO
ASESOR TECNICO MANTO.
DR. BALMIS No. 148
CIRCUITO RIO DEL ORO No. 71-A
PASEOS DE CHURUBUSCO
DELEGACION IZTAPALAPA

- 26.- HEREDIA GONZALEZ HECTOR
PLANEACION Y PROYECTOS
JEFE DEPTO. INSTRUMENTACION
BOSQUES DE CIRUELOS No. 186
COL. BOSQUES DE LAS LOMAS
596-43-66 ext. 186
AV. MORELOS No. 170
SAN ANDRES AZCAPOTZALCO
DELEGACION AZCAPOTZALCO
382-05-87
- 27.- HERNANDEZ IBANEZ LEONCIO
PETROLEOS MEXICANOS
SUPERVISOR DE TRAB. DE CONSTRUC.
CONOCIDO TOLOME MPIO. DE PASO DE
OVEJAS, VER.
- 28.- HERRERA VELAZQUEZ JOSE
S. C.T.
- 29.- KUN GONZALEZ JEAN PIERRE
LABORATORIOS ELECTRONICOS
MEXICANOS, S.A. DE C.V.
- 30.- LEYVA ALFARO FERNANDO
PRODUCTOS LORAIN DE MEXICO
ING. DE SERVICIO
AV. ANDRES AFOFO No. 1659
NAUCALPAN DE JUAREZ EDO. MEX.
CUITLAHUAC No. 4
COL. SAN JAVIER
TLALNEPANTLA
54030 EDO. DE MEXICO
565-93-09
- 31.- LEYVA ROJO LORENZO
GRUPO P. C.
GERENTE SERVICIO
PLAN DE SAN LUIS No. 398
556-45-45
VILLA NETZAHUALCOYOTL No. 14
DELEGACION GUSTAVO A. MADERO
07550 MEXICO, D.F.
796-91-30
- 32.- LOPEZ RODRIGUEZ MARCO ANTONIO
CONSTRUCCIONES E INSTALACIONES
METALICAS Y ELECTRONICAS
STA. CECILIA No. 10
COL. MOLINO STO. DOMINGO
DELEGACION ALVARO OBREGON
01130 MEXICO, D.F.
271-01-66
- 33.- MADRID GUTIERREZ JESUS ALBERTO
CONDUMEX, S.A. DE C.V.
SUPERVISOR DE COMUNICACIONES
PONIENTE 140 No. 720
COL. VALLEJO
DELEGACION GUSTAVO A. MADERO
587-36-09
ANDADOR 45 DE TEMOLUCO CASA 12-1
DELEGACION GUSTAVO A. MADERO
391-59-83
- 34.- MAGALLANES CASTRO SALVADOR
PETROLEOS MEXICANOS
COORDINADOR DE CONSTRUC. COSTA
FUERA
G.P. EXZONA MARINA
CD. DEL CARMEN, CAMPECHE
207-36
HACIENDA MOCHITILITIC No. 1595
GUADALAJARA, JAL.
38-21-27
- 35.- MARTINEZ DIAZ EDUARDO
S. C. T.
ANALISTA SIST. ESP. COMPUTO
AV. LAZARO CARDENAS No. 657
COL. NARVARTE
DELEGACION BENITO JUAREZ
530-30-60
VIOLETA No. 93-8
COL. GUERRERO
DELEGACION CHAUHTEMOC
06300 MEXICO, D.F.
530-30-60- ext. 752

36.- MEJIA ALBERTO ANGEL
BANDO DE MEXICO
INGENIERO EN COMUNICACIONES
5 DE MAYO No. 2
COL. CENTRO
DELEGACION CUAUHTEMOC
06059 MEXICO, D.F.
512-81-55

GAVIOTA No. 15-21
FRAC. LA CANADA
DELEGACION ATIZAPAN
54500 MEXICO, D.F.
398-69-50

37.- MENEZ JAIMES EDUARDO
GRUPO NACIONAL PROVINCIAL
JEFE DEPTO. TELEPROCESO
MIGUEL ANGEL DE QUEVEDO No. 915
COL. COYOACAN
DELEGACION COYOACAN
549-79-41

38.- MIRAMONTES FLORES ANTONIO
BANCO INTERNACIONAL
TECNICO
PASEO DE LA REFORMA No. 156
COL. JUAREZ
DELEGACION MIGUEL HIDALGO
566-00-26

EDIFICIO H2 ENT. 2 DEPTO. 3
LOMAS DE PLATEROS
DELEGACION VILLA ALVARO OBREGON
0082 MEXICO, D.F.
593-88-93

39.- MORENO CAMARGO JOSE GUADALUPE
PEMEX
ENCARGADO MANTO...
COL. EL LIBRO
MUNICIPIO DE ATUTOLUQUITO

PRODUCTOS QUIMICOS DE MEX. No. 7
COL. VISTA HERMOSA
DELEGACION TLALNEPANTLA
54080 MEXICO, D.F.
398-74-72

40.- PADILLA URANGA EDUARDO
S. C.T.
CINTOTECARIO
CLAZ. DR. DE LAS BOMBAS No. 411
COL. SAN BARTOLO CDAPA
DELEGACION COYOACAN
591-33-55 ext. 2636

CALLE 2 No. 80
COL. ESPARTACO
DELEGACION COYOACAN
04870 MEXICO, D.F.
684-26-17

41.- PALACIOS OLIVARES GREGORIO
PEMEX
SUPERVISOR DE OBRAS
CD. DEL CARMEN CAMPECHE

CENTRO ESCOLAR N-21 No. 84

42.- PARRAZAL BALTIERREZ VICTOR MANUEL
U. N. A. M.
PROFESOR
CIUDAD UNIVERSITARIA

CVA. ROSAS DE NAVIDAD No. 5
XOCHIMILCO
16090 MEXICO, D.F.

43.- PAULINO DOMINGUEZ ANSELMO
S. C.T.
TECNICO ANALISTA
AV. DE LAS TELECOMUNICACIONES
COL. ELMORAL
DELEGACION IXTAPALAPA
692-00-77 ext. 240

FF CC, CUERNAVACA No. 86
BELLAVISTA
DELEGACION ALVARO OBREGON
01140 MEXICO, D.F.

44.- PECH CARRERA MIGUEL ANGEL
TELEFONOS DE MEXICO
SUBGERENCIA DE CONSULTORIA
PARQUE VIA No. 190-50. PISO
COL. SAN RAFAEL
222-53-44

AV. DEL ROSAL No. 290
EDIF. 20 DEPTO. 401
COL. MOLINO DE ROSAS
DELEGACION ALVARO OBREGON
01470 MEXICO, D.F.
651-39-36

45.- PEREZ NERI I. GUILLERMO
GRUPO CONDUMEX, S.A.
GERENTE DE COMUNICACIONES
JOAQUIN GALLO No. 186
COL. COYOACAN
587-86-09

SOR JUANA INES DE LA CRUZ No. 136F
COL. CUAUHTEMOC
06400 MEXICO, D.F.
547-61-23

46.- RAMIREZ UBALDO FACUNDO
DIREC. GRAL. TELECOM.
JEFE COORDINACION TECNICA
AV. DE LAS TELECOMUNICACIONES
ZONA URBANA DEL MORAL
IZTAPALAPA
692-00-77 ext. 170

CALLE LIBERTAD No. 126
IZTAPALAPA
09100 MEXICO, D.F.
763-44-17

47.- RAMOS CASTILLEJOS RENE
BANCO INTERNACIONAL
GTE. DIV. MONTO. COMPUTO
PASADIZO DE LA REFORMA No. 156-50. PISO
COL. JUAREZ
DELEGACION CUAUHTEMOC
06600 MEXICO, DF.
566-00-25

EDF. NARCISO MENDEZ ENT. F
DEPTO. 23
COL. UN. NONOALCO TLATELOLCO
DELEGACION CUAUHTEMOC
06900 MEXICO, D.F.

48.- REYES MIRANDA JAVIER ALBERTO
BANCO DE MEXICO
INGENIERO EN COMUNICACIONES
5 DE MAYO No. 2
COL. CENTRO
DELEGACION CUAUHTEMOC
06059 MEXICO, DF.
512-81-55

49.- SALAZAR ALVIAR MARTIN
DIREC. GRAL. ESC. SEC. TEC.
ASISTENTE ACTIVIDADES TECNOLOGICAS
BOLIVAR No. 19
COL. CENTRO
521-67-99

AZCAPOTZALCO No. 356
COL. LA FLORIDA
DELEGACION E. MEXICO
55120 MEXICO, D.F.
567-21-11

- 50.- SANCHEZ AGUIRRE MA. DE LOS ANGELES
 PROCESO Y SISTEMAS DE INFORMACION
 INGENIERO DE SERVICIO
 MINERIA No. 145
 COL. ESCANDON
 DELEGACION MIGUEL HIDALGO
 11800 MEXICO, D.F.
 516-04-60 ext. 607
- TOLTECAS No. 152
 COL. STA. BARBARA
 DELEGACION IZTAPALAPA
 09000 MEXICO, D.F.
 587-80-58
- 51.- SANDOVAL MONTANO CARLOS
 INSTITUTO MEXICANO DEL SEGURO SOCIAL
 SUPERVISOR DE SIST. DE TELECOMUN.
 AV. PASEO DE LA REFORMA No. 476
 100. PISO
 COL. JUAREZ
 211-25-86
- PASEO DE LOS DURAZNOS No. 84
 TAXQUENA
 DELEGACION COYOACAN
 04250 MEXICO, D.F.
 211-37-01
- 52.- SARTORIUS WITTE CARLOS E.
 MOTOROLA DE MEXICO, S.A
 INGNEIERO DE SIST. RADIOCOMUNICAC.
 TONALA No. 59
 COL. ROMA
 DELEGACION CUAUHTEMOC
 06700 MEXICO, D.F.
 533-04-00
- AV. TRES No. 130
 DELEGACION BENITO JUAREZ
 03800 MEXICO, D.F.
 516-80-95
- 53.- SUAREZ MARTINEZ CECILIA
 U. N. A. M.
 INVESTIGADORA
 CONOCIDO
- 5 DE MAYO No. 345
 TEPEPAN-XOCHIMILCO
 16020 MEXICO, D.F.
 676-77-05
- 54.- VAZQUEZ CRUZ MA. DEL CARMEN
 S.E.D.U.E.
 PROYECTISTA
 REFORMA No. 20-50. PISO
 COL. JUAREZ
 DELEGACION CUAUHTEMOC
 06030 MEXICO, D.F.
 535-80-85 y 535-11-90
- CALLE WASHINGTON No. 34-7
 COL. TICOMAN
 DELEGACION GUSTAVO A. MADERO
- 55.- VERTIZ ALCOCER ENRIQUE
 PEMEX
 INGENIERO PROYECTISTA
 AV. MARINA NACIONAL No. 329
 COL. ANAHUAC
 254-41-34
- ARBOLITO No. 6912
 COL. TRES ESTRELLAS
 DELEGACION GUSTAVO A. MADERO
 07820 MEXICO, D.F.
 750-15-19
- 56.- ZAPOTA CRUZ JUAN MANUEL
 S. C. T.
 JEFE SERV. MOVILES MARITIMOS
 Y AERONAUTICOS
 AV. DE LAS TELECOMUNICACIONES
 COL. EJIDOS DEL MORAL
 DELEGACION IZTAPALAPA
 652-00-11 ext. 281 y 287
- CARUSO No. 7
 COL. EXHIPODROMO DE PERALVILLO
 DELEGACION CUAUTEMOC
 06260 MEXICO, D.F.