



DIVISION DE EDUCACION CONTINUA
FACULTAD DE INGENIERIA U.N.A.M.

INTRODUCCION A LOS MICROPROCESADORES (Z-80)

1982

1900

1901

1902

1903

1904

1905

1906

1907

1908

1909

1910

1911

1912

1913

1914

1915

1916

1917

REPUBLIC DE EDU...

1918

CURSO
MICROS

- CONCEPTOS BASICOS DE ELECTRONICA
- CONCEPTOS BASICOS DE ELECTRONICA DIGITAL
- CONCEPTOS DE PROGRAMACION
- LENGUAJE DE PROGRAMACION
- MICROPROCESADOR MICRO
- PERIFERICOS
- APLICACIONES
- LABORATORIO

CONCEPTOS
BASICOS DE
ELECTRONICA

- PRINCIPALES DE ELECTRONICA
- ELEMENTOS LOGICOS
- ALGEBRA BOOLEANA
- CIRCUITOS INTEGRADOS
- FAMILIAS LOGICAS
- MINIMIZACION F. BOOLEANAS
- SISTEMAS DE NUMERACION
- ARITMETICA DIGITAL PARA NUMEROS NO SIGNADOS
- ARITMETICA DIGITAL PARA NUMEROS SIGNADOS
- CODIGOS
- CIRC. DIGITALES BASICOS
- MEMORIAS
- MICROPROCESADORES

Handwritten text in the left column, appearing to be a list or set of notes. The text is extremely faint and illegible due to the quality of the scan.

Handwritten text in the right column, appearing to be a list or set of notes. The text is extremely faint and illegible due to the quality of the scan.

CONCEPTOS BASICOS

VOLTAJE = POTENCIAL QUE GENERA LA CORRIENTE

UNIDAD: [VOLTS] [V]

Ej.: BATERIAS, ACUMULADORES

- BATERIAS (CARACT.)
- POTENCIAL
 - BORNES + y -
 - ENERGIA QUE ENTREGA
 - SIMBOLO $\frac{+}{|}{-}$
 - PUEJEN CONECTARSE EN SERIE

RESISTENCIA = OPPOSICION AL FLUJO DE ELECTRONES

(R)

UNIDAD: [OHMS] [Ω]

1000 Ω = 1K Ω

1000 K Ω = 1M Ω

SIMBOLO GRAFICO

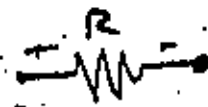

RESIST. CARBON



- A: 1er DIGITO
- B: 2o DIGITO
- C: POTENCIA DE DISEÑO
- D: TOLERANCIA

COLORES:

- | | | |
|--------------|---|-----------|
| NEGRO | 0 | ORO 5% |
| CAFE | 1 | PLATA 10% |
| ROJO | 2 | |
| NARANJA | 3 | |
| AMAR. | 4 | |
| VERDE | 5 | |
| AZUL | 6 | |
| ULTRAVIOLETA | 7 | |
| GRIS | 8 | |

(2)

TIPOS DE CONEX.

a) SERIE



b) PARALELO

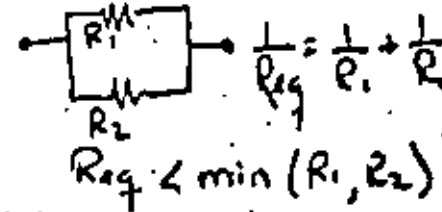

CORRIENTE = FLUJO DE ELECTRONES

UNIDAD: AMPERES [A] $\leftarrow \begin{matrix} \text{mA} \\ \text{uA} \end{matrix}$

LEY DE OHM

$I = \frac{V}{R}$ o' $V = RI$

RANGO APROX. EN CIRCUITO <math>I < 1A</math>



LEYES DE KIRCHHOFF

a) VOLTAJE $\sum V_i = 0$ EN UNA MALLA CERRADA

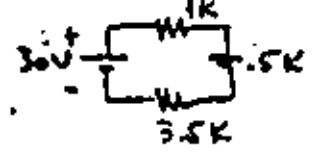

b) CORRIENTE $\sum I_i = 0$ EN UN NUDO



1875

The first part of the document discusses the general principles of the proposed system, which is designed to improve the efficiency of the government's operations. It is based on the idea of a central authority that can coordinate the activities of various departments and agencies. This central authority will be responsible for the distribution of resources and the supervision of the work of the lower levels of the government.

The second part of the document describes the specific details of the proposed system. It outlines the structure of the central authority and the way it will interact with the various departments and agencies. It also discusses the methods of resource allocation and the way in which the work of the lower levels will be supervised.

The third part of the document discusses the advantages of the proposed system. It points out that the system will lead to a more efficient and economical government, and that it will also lead to a more uniform and consistent administration. It also discusses the way in which the system will be implemented and the way in which it will be maintained.

The fourth part of the document discusses the objections to the proposed system. It points out that the system will require a large amount of money and that it will also require a large amount of time and effort to implement. It also discusses the way in which these objections can be overcome.

The fifth part of the document discusses the conclusion of the proposed system. It points out that the system is a necessary and desirable reform, and that it should be implemented as soon as possible.

DIODOS: PERMITEN EL FLUJO DE CORRIENTE EN UN SOLO SENTIDO. (SWITCH)

SIMBOLO GRAFICO

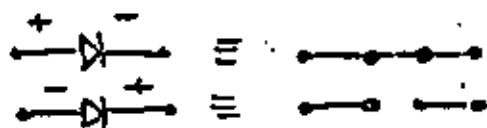
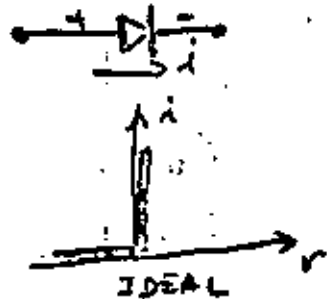
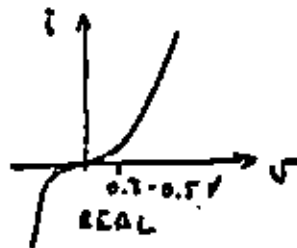

TRANSISTOR = DISPOSITIVO CREADO CON 3 CAPA DE SEMICONDUCTORES

- USOS:
- FTE DE CORRIENTE
 - AMPLIF. DE CORR.
 - INVERSION
 - OTROS

APLIC. SIST. DIGITALES: SWITCH

SIMBOLO GRAFICO

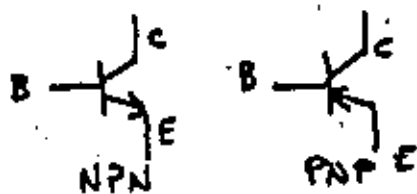

$$i_c = \beta i_b$$

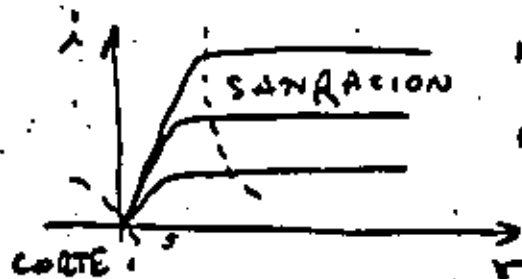

NPN - POLARIZ. POSIT.

PNP - POLARIZ. NEGAT.

③

FUNCIONAMIENTO

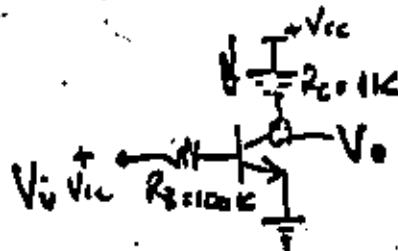

VOLTAJE	N. LOGICO
0V	0
+5V	1

ELEMENTOS LOGICOS

CARACTERISTICA: MANEJAN SEÑALES BINARIAS (0 y 1)

COMPUERTAS LOGICAS: DISPOSITIVOS ELECTRONICOS QUE DAN UNA SALIDA COMO FUNCION DE UNA O VARIAS ENTRADAS. TODAS LAS VAR. DE ENTRADA Y SALIDA SON BINARIAS

TABLAS DE VERDAD: REPRESENTACION EN FORMA TABULAR DE LA RELACION ENTRE LAS VAR. DE ENTRADA Y LAS DE SALIDA (PARA TODAS LAS COMBINACIONES DE LAS VAR. DE ENTRADA).

NOMBRE	SÍMBOLO	F. ALGEBRAICA	T. DE VERDAZ															
AND		$X = AB$	<table border="1"> <tr><th>A</th><th>B</th><th>X</th></tr> <tr><td>0</td><td>0</td><td>0</td></tr> <tr><td>0</td><td>1</td><td>0</td></tr> <tr><td>1</td><td>0</td><td>0</td></tr> <tr><td>1</td><td>1</td><td>1</td></tr> </table>	A	B	X	0	0	0	0	1	0	1	0	0	1	1	1
A	B	X																
0	0	0																
0	1	0																
1	0	0																
1	1	1																
OR		$X = A + B$	<table border="1"> <tr><th>A</th><th>B</th><th>X</th></tr> <tr><td>0</td><td>0</td><td>0</td></tr> <tr><td>0</td><td>1</td><td>1</td></tr> <tr><td>1</td><td>0</td><td>1</td></tr> <tr><td>1</td><td>1</td><td>1</td></tr> </table>	A	B	X	0	0	0	0	1	1	1	0	1	1	1	1
A	B	X																
0	0	0																
0	1	1																
1	0	1																
1	1	1																
INVERSOR (NEM.)		$X = A' = \bar{A}$	<table border="1"> <tr><th>A</th><th>X</th></tr> <tr><td>0</td><td>1</td></tr> <tr><td>1</td><td>0</td></tr> </table>	A	X	0	1	1	0									
A	X																	
0	1																	
1	0																	
BUFFER		$X = A$, amplifica corriente	<table border="1"> <tr><th>A</th><th>X</th></tr> <tr><td>0</td><td>0</td></tr> <tr><td>1</td><td>1</td></tr> </table>	A	X	0	0	1	1									
A	X																	
0	0																	
1	1																	
NAND		$X = (AB)'$	<table border="1"> <tr><th>A</th><th>B</th><th>X</th></tr> <tr><td>0</td><td>0</td><td>1</td></tr> <tr><td>0</td><td>1</td><td>1</td></tr> <tr><td>1</td><td>0</td><td>1</td></tr> <tr><td>1</td><td>1</td><td>0</td></tr> </table>	A	B	X	0	0	1	0	1	1	1	0	1	1	1	0
A	B	X																
0	0	1																
0	1	1																
1	0	1																
1	1	0																
NOR		$X = (A+B)'$	<table border="1"> <tr><th>A</th><th>B</th><th>X</th></tr> <tr><td>0</td><td>0</td><td>1</td></tr> <tr><td>0</td><td>1</td><td>0</td></tr> <tr><td>1</td><td>0</td><td>0</td></tr> <tr><td>1</td><td>1</td><td>0</td></tr> </table>	A	B	X	0	0	1	0	1	0	1	0	0	1	1	0
A	B	X																
0	0	1																
0	1	0																
1	0	0																
1	1	0																
XOR non		$X = A \oplus B = A'B + AB'$	<table border="1"> <tr><th>A</th><th>B</th><th>X</th></tr> <tr><td>0</td><td>0</td><td>0</td></tr> <tr><td>0</td><td>1</td><td>1</td></tr> <tr><td>1</td><td>0</td><td>1</td></tr> <tr><td>1</td><td>1</td><td>0</td></tr> </table>	A	B	X	0	0	0	0	1	1	1	0	1	1	1	0
A	B	X																
0	0	0																
0	1	1																
1	0	1																
1	1	0																
XNOR p. par.		$X = A \odot B = A'B' + AB$	<table border="1"> <tr><th>A</th><th>B</th><th>X</th></tr> <tr><td>0</td><td>0</td><td>1</td></tr> <tr><td>0</td><td>1</td><td>0</td></tr> <tr><td>1</td><td>0</td><td>0</td></tr> <tr><td>1</td><td>1</td><td>1</td></tr> </table>	A	B	X	0	0	1	0	1	0	1	0	0	1	1	1
A	B	X																
0	0	1																
0	1	0																
1	0	0																
1	1	1																

ALGEBRA BOOLEANA = TRATA CON VARIABLES BINARIAS Y LAS OPERACIONES LOGICAS:
 AND
 OR
 COMPLEMENTO

FUNCION BOOLEANA ES UNA EXPRESION ALGEBRAICA QUE CONTIENE:
 - VARIABLES BINARIAS
 - SIMBOLOS DE F. LOGICAS
 - AGUIERE DOS VALORES 1 o 0

Ejemplo

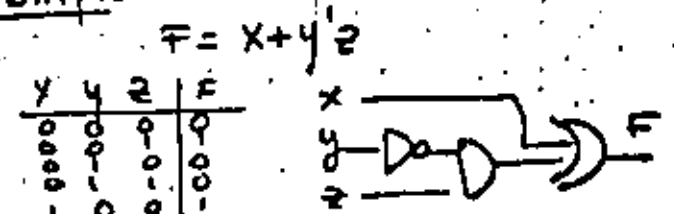

TEOREMAS DEL ALGEBRA BOOLEANA

- $x + 0 = x$
- $x + 1 = 1$
- $x + x = x$
- $x + x' = 1$
- $x + y = y + x$
- $x + (y + z) = (x + y) + z$
- $x + (y \cdot z) = (x + y) \cdot (x + z)$
- $(x + y)' = x' \cdot y'$
- $(x')' = x$
- $x \cdot 0 = 0$
- $x \cdot 1 = x$
- $x \cdot x = x$
- $x \cdot x' = 0$
- $x \cdot y = y \cdot x$
- $x \cdot (y + z) = (x \cdot y) + (x \cdot z)$
- $(x \cdot y)' = x' + y'$

$x \cdot y' + y = x + y$
 $f = \int$
 $x + \bar{x}y = x + y$

DE LAS LEYES DE MORGAN

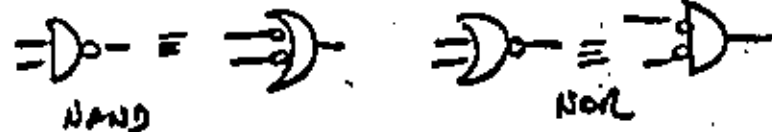

EJEMPLO:

1. $f = [(A' + B) \cdot B']'$



CIRCUITOS INTEGRADOS (IC, CHIPS)

5

QUE SON SEMICONDUCTORES CON ELEMENTOS MONTADOS EN UN PAQUETE DE CERAMICA Y PATA EXTERNAS

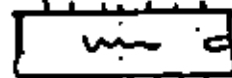

VENTAJAS

- REDUCC. DE TAMAÑO
- REDUCC. DE COSTO
- REDUCC. DE CONSUMO DE POTENCIA
- MAYOR CONFIABILIDAD
- VELOCIDAD + ALTA
- MENOS CONEXIONES EXTERNAS

TIPOS

- LINEALES: AMPLIF. OPERACIONALES, COMPADADORES, REGULADORES DE VOLTAJE
- DIGITALES: COMPUERTAS, FF, REGISTROS, CONTADORES, SUMADORES, ALU, MEMORIAS

FAMILIAS LOGICAS USADAS

- RTL
- DTL
- TTL
- ECL
- MOS
- CMOS

PARAMETROS MAS IMPORTANTES

- FAN IN
- FAN OUT
- DISIPACION DE POTENCIA (POWER DISSIPATION)
- RETRASO (PROPAGATION DELAY)
- MARGEN DE RUIDO (NOISE MARGIN)

FAN OUT ~ 10
 NOISE MARGIN ~ 0.4V
 ENTRADA ABIERTA = AUTO

VERSIONES		ns	mW
ESTANDAR	TTL	10	10
LOW POWER	L TTL	33	1
HIGH SPEED	H TTL	6	22
SHOTKY	S TTL	3	19
LOW POWER SHOTKY	L S TTL	1.5	2

TTL

CONFIGURACIONES A LA SALIDA PARA C/VERSION

OPEN COLLECTOR: REQUIERE RESISTOR EXTERNO A LA SALIDA CONECTADA A V_{CC}

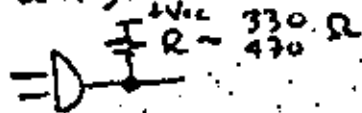

PERMITE WIRE-AND

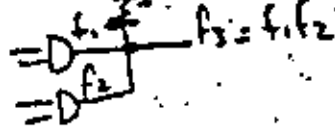

TOTEM POLE: SALIDA ESTANDAR POR RETRASO, MAY FAN OUT

THRESTATE: 3 ESTADOS DE SALIDA

- * 1
- * 0
- * ALTA IMPEDANCIA CMOS

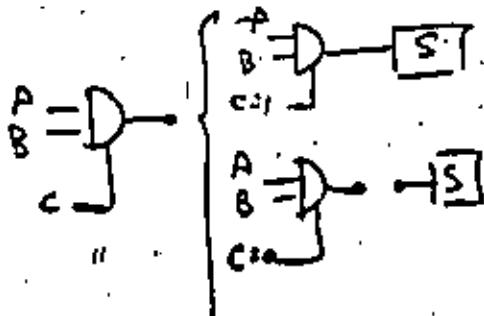

(B) ECL

- TRABAJAN EN NO SATURACION
- RETRASO ~ 2 ns
- DISIPACION ~ 25 mW
- FAN OUT > 25
- NOISE MARGIN = 0.2 V



PERMITE FORMAR WIRE-OR

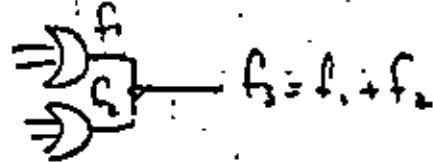

MOS

- PMOS - Polariz. negat.
- NMOS - Polariz. posit.
- NO COMPATIBLE CON TTL
- RETRASO > ECL y TTL
- ALTA DENSIDAD
- BAJO CONSUMO DE POTENCIA (10 mW)
- USOS: MEMORIAS, ALU

- COMPATIBLE CON TTL
- PMOS + NMOS
- FAN OUT > 50
- DISIPACION ~ 10 mW
- DELAY ~ 25 ns

ESCALA DE INTEGRACION

SSI	< 10
MSI	(10, 100)
LSI	(100, 1000)
VLSI	> 1000

MINIMIZACION

FORMAS CANONICAS

$$\Sigma \text{ de } \Pi : f(x_1, \dots, x_n) = \underbrace{(x_1 \bar{x}_2 \dots x_n)}_{\text{minitérminos}} + (x_1 \dots x_n) + \dots$$

$$\Pi \text{ de } \Sigma : f(x_1, \dots, x_n) = \underbrace{(x_1 + x_2 + \dots + x_n)}_{\text{maxitérminos}} \cdot (\bar{x}_1 + \dots + \bar{x}_n) \cdot \dots$$

$f = \Sigma$ de minitérminos para los cuales $f=1$
 $f = \Pi$ de maxitérminos para los cuales $f=0$

F	X	Y	Z	minitérminos	maxitérminos
0	0	0	0	$x'y'z'$ m_0	$x+y+z$ M_0
0	0	0	1		
0	0	1	0		
0	0	1	1		
0	1	0	0		
0	1	0	1		
0	1	1	0		
1	1	1	1	xyz m_7	$x'+y'+z'$ M_7

$M_i = \bar{m}_i$
 $f = \Sigma (1, 4, 7) = m_1 + m_4 + m_7$
 $f = \Pi (0, 2, 3, 5, 6) = M_0 \cdot M_2 \cdot M_3 \cdot M_5 \cdot M_6$

MÉTODOS DE REDUCCION

- ALGEBRA BOOLEANA
- MAPAS DE KARNAUGH
- QUINE Mc CLUSKEY

②

MAPAS DE KARNAUGH

- REPRESENTACION GRAFICA DE TABLA DE VERDAD
- TABLERO CON 2^n CUADROS SI HAY n VARIABLES DE ENTRADA
- CUADRO = MINITERMINO
- VALOR CUADRO = VALOR DE LA FUNCION PARA EL MINITERMINO
- UTIL HASTA PARA 5 VAR
- LOS CUADROS SE ALINEAN DE MANERA QUE SOLO DIFIERAN EN UN BIT DOS CUADROS ADYACENTES.
- EJEMPLO

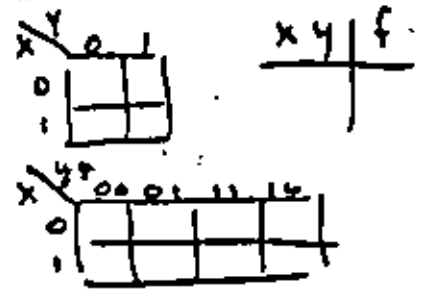

SISTEMAS DE NUMERACION

METODO

- TRAZAR TABLERO CON 2ⁿ CUADROS PARA n VAR. DE ENTRADA
- NUMERAR CUADROS EN FORMA TAL QUE LOS ADYACENTES DIFIERAN EN UN BIT.
- LEER TABLERO
- AGRUPAR LOS UNOS FORMANDO CONJUNTOS QUE SEAN LO MAS GRANDE POSIBLE. #ELEMENTOS EN EL CONJUNTO = 2ⁱ
- ESCOGER MINIMA CANTIDAD DE CONJUNTOS QUE CUBRA TODOS LOS UNOS (MAYORES PRIMOS)
- ENCONTRAR LA REPRESENTACION ALGEBRAICA DE LOS I.P.
- $f = \sum$ DE I.P.

$$f(w, x, y, z) = \sum (0, 1, 2, 4, 6, 8, 9, 12, 13, 14)$$

EJEMPLO

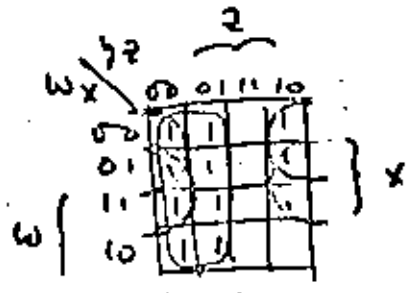

$$f = \bar{y} + y\bar{z} + \bar{w}z$$

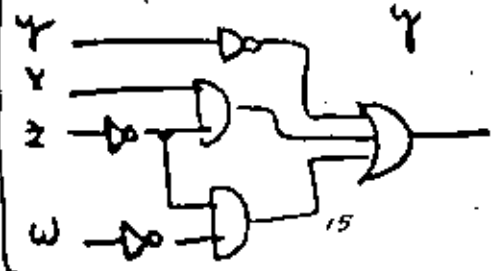

RAZON { COMPUTADORA DIGITAL MANEJA SERIALES BINARIAS (1, 0)

SIST. DE NUM. DE BASE M

- EMPLEA M DIGITOS (0, ..., M-1) PARA REPRESENTAR LOS VALORES NUMERICOS
- EJEMPLO
 - * DECIMAL 0-9
 - * BINARIO 0, 1
 - * OCTAL 0-7
 - * HEXA 0-F

CONVERSION BASE M BASE 10

$$a_n a_{n-1} \dots a_0 \cdot a_{-1} a_{-2} \dots a_{-n} \text{ [M]} = \sum_{i=-n}^n a_i \cdot M^i$$

- EJEMPLO

1010110.01 [2]

7624.3 [8]

REPRESENTACION PARA VALORES DIGITALES

- INFORMACION DE TIPO BINARIA
- ELEMENTO BASICO DE INFORMACION = 1 DIGITO BINARIO = BIT
- 1 BYTE = 8 BITS
- PALABRA = $\begin{cases} 1 & \text{BYTE} \\ 2 & \\ 3 & \end{cases}$
- SIST. BINARIO { 0, 1
- SIST. OCTAL { 0, 1, 2, 3, 4, 5, 6, 7
- SIST. HEXADEC. { 0, 1, ..., 9, A, B, C, D, E, F

CONVERSION
BINARIA,
OCTAL,
HEXADEC.

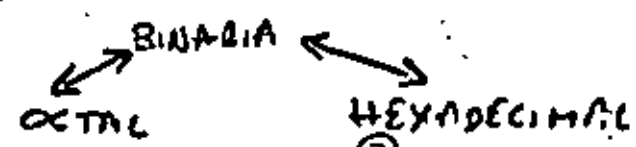

a) BINARIA \rightarrow OCTAL $2^3 = 8$
 - DIVIDIR # BIN. EN PERIODOS DE 3
 $\leftarrow 0 \rightarrow$
 - OBTENER # DEC. EQUIVALENTE EN CADA PERIODO

101 011 101 011 11011

b) OCTAL \rightarrow BINARIA
 - REEMPLAZAR CADA DIGITO OCTAL POR SU EQUIVALENTE BINARIO
 5072.418

c) BINARIA \rightarrow HEXADECIMAL $2^4 = 16$
 - DIVIDIR # BIN. EN PERIODOS DE 4
 $\leftarrow 0 \rightarrow$
 - OBTENER # DEC. EQUIVALENTE EN CADA PERIODO

11010 11101011 110111011 (2)

d) HEXADEC. \rightarrow BINARIO
 - REEMPLAZAR CADA DIGITO HEXADECIMAL POR SU EQUIVALENTE BINARIO
 ABC.E9

CONVERSION DE
BASE 10
A
BASE M

- SEPARAR # DECIMAL EN PARTE ENTERA Y FRACCIONARIA

$$A_{(10)} = A_E + A_F$$

a) PARTE ENTERA $_{(10)} \rightarrow$ PARTE ENTERA $_{(M)}$
 - DIVIDIR SUCESSIVAMENTE A_E POR M
 - LOS RESIIVOS OBTENIDOS SON LOS DIGITOS EN BASE M DE LA PARTE ENTERA.

M	A_E	RESIIVOS
M	N_1	B_0
M	N_1	B_1
	\vdots	
M	N_n	B_{n-1}
	0	B_n

LEER C
ESTA
DIRECCIO

$$B_{E(M)} = B_n B_{n-1} \dots B_0$$

$$41_{(10)} \rightarrow (2), (2), (16)$$

b) PARTE FRACC. $_{(10)} \rightarrow$ PARTE FRACC. $_{(M)}$
 - MULTIPLICAR SUCESSIVAMENTE A_F POR M (LAS FRACCIONES RESULTANTES) POR M.
 - LAS PARTES ENTERAS QUE SE OBTENGAN CORRESPONDEN A LOS DIGITOS EN BASE M DE LA PARTE FRACCIONARIA.

ARITMETICA DIGITAL (NUMEROS NO SIGNADOS)

LEER EN ESTA DIRECCION ↓

$$\begin{array}{r} A_F \\ \times M \\ \hline B_{i-1} \cdot N_{i-1} \\ \times M \\ \hline B_{i-2} \cdot N_{i-2} \\ \times M \\ \hline B_{i-3} \cdot N_{i-3} \\ \dots \end{array}$$

$B_F [n] = 0 B_{i-1} B_{i-2} B_{i-3} \dots$

CLAS [10] → [2], [8], [16]

$- B [n] = B_E \cdot B_F$

SUMA

BASE 10

$$\begin{array}{r} \leftarrow C_{i+1} \\ 174 \leftarrow A_i \\ \underline{229 \leftarrow B_i} \\ 403 \leftarrow S_i \end{array}$$

$S_i = A_i + B_i + C_i - n (M)$
 $S_i \in [0, M-1]$
 $C_{i+n} = n$

BASE 2

$$\begin{array}{l} 0+0=0 \\ 0+1=1 \\ 1+0=1 \\ 1+1=10 \end{array}$$

$$\begin{array}{r} 111010 \\ + 011101 \\ \hline \end{array}$$

BASE 8

$$\begin{array}{r} 7425 \\ + 6237 \\ \hline \end{array}$$

RESTA $A - B = A + (-B)$ ← SIGNADO

MULTIPLICACION

BASE 10

$$\begin{array}{r} \leftarrow C_P \\ 16 \leftarrow A_i \\ \times 12 \leftarrow B_i \\ \hline 32 \leftarrow P_i \\ \underline{16} \\ 192 \end{array}$$

$P_i = A_i B_i + C_P - n (M)$
 $P_i \in [0, M-1]$
 $C_{P+i} = n$

BASE 2

$$\begin{array}{l} 0 \times 0 = 0 \\ 0 \times 1 = 0 \\ 1 \times 0 = 0 \\ 1 \times 1 = 1 \end{array}$$

$$\begin{array}{r} 1011101 \\ \times 101 \\ \hline \end{array}$$

BASE 8

$$\begin{array}{r} 527 \\ \times 37 \\ \hline 4541 \\ 2005 \\ \hline 24611 \end{array}$$

DIVISION

BASE 10

$$\begin{array}{r} \overline{) 340} \\ \underline{-30} \\ 40 \\ \underline{-40} \\ 0 \end{array}$$

CO: A/B

A/B

CO: = { 0, A/B }
 max(n) → -nxB/A

R: = A - nxB

* NUMERO QUE DEBE SER SUMADO A nxB PARA OBTENER A.

BASE 2

0/0 > NO TIENE SENTIDO

0/1 = 0 RESCO

1/1 = 1 RESCO

Ejemplos

$$\begin{array}{r} \overline{) 10010} \\ \underline{-110} \\ 110 \\ \underline{-110} \\ 000 \end{array}$$

12

ARITMETICA BINARIA (NUMEROS SIGNADOS)

* SE REQUIERE UN BIT EXTRA PARA REPRESENTAR EL SIGNO

TIPOS DE REPRESENTACIONES

- MAGNITUD Y SIGNO
- 1' COMPLEMENTO
- 2' COMPLEMENTO

BIT DE SIGNO EN REPRESENTACION

1 ⇒ -

0 ⇒ +

1' COMPLEMENTO DE # BINARIO

- COMPLEMENTAR TODOS LOS BITS DE LA PALABRA

1 → 0

0 → 1

1011.01 # BINARIO

0100.10 1' COMPL.

2' COMPLEMENTO DE # BINARIO

- SE OBTIENE SUMANDO 1' AL 1' COMPLEMENTO DEL NUMERO BINARIO

1011.01 # BINARIO

0100.10 1' COMPL.

+ 1

0100.11 2' COMPL.

- COMPLEMENTAR BITS A PARTIR DEL 1er BIT = 1 (SE USA 120.)

REPRESENTACION DE LOS SIGNOS EN 2' COMPLEMENTO CON 'N' BITS

- # POSITIVO
 - REPRESENTAR MAGNITUD EN FORMA BINARIA EMPLEANDO $n-1$ BITS
 - HACER BIT DEL SIGNO (n) = 0
- # NEGATIVO
 - REPRESENTAR MAGNITUD EN FORMA BINARIA EMPLEANDO $n-1$ BITS
 - HACER BIT DE SIGNO (n) = 0
 - OBTENER 2' COMPLEMENTO DE LOS 'N' BITS

- PARA CONOCER LA MAGNITUD DE UN # NEGATIVO (BIT DE SIGNO = 1), OBTENER EL 2' COMPLEMENTO DE LOS 'N' BITS Y LEER LA MAGNITUD EN LOS $n-1$ BITS.

- EJEMPLO EMPLEAR 4 BITS PARA ± 5
 - RANGO DE VALORES REPRESENTABLES
 $-2^{n-1} \leq x \leq 2^{n-1} - 1$

(13)

- SUMA
 $S = A + B$
- SUMAR LOS DOS NUMEROS (INCLUYENDO BIT DE SIGNO), DESECHAR EL BIT DE ACARRA QUE SE OBTENGA AL SUMAR LOS BITS DEL SIGNO (CARRY OUT)
 - RESULTADO ES VALIDO CUANDO:
 - NI ENTRA NI SALE CARRY DEL BIT DE SIGNO
 - ENTRA Y SALE CARRY DEL BIT DE SIGNO
 - EJEMPLO

$$\begin{array}{r} 5 \\ + 6 \\ \hline 6 \\ + (-5) \\ \hline 1 \\ + 5 \\ \hline 6 \\ + (-6) \\ \hline 0 \\ + (-5) \\ \hline -5 \end{array}$$

RESTA
 $R = A - B = A + (-B)$

- MULTIPLICACION
 $M = A \times B$
- OBTENER PRODUCTO DE $|A| \times |B|$
 - OBTENER 2' COMPLEMENTO DEL RESULTADO CUANDO
 - $A > 0, B < 0$
 - $A < 0, B > 0$
 - EL PRODUCTO TENDRA 2N BITS DE MAGNITUD

- DIVISION
 $D = A / B$
- OBTENER EL COCIENTE $|A| / |B|$
 - OBTENER 2' COMPLEMENTO DEL RESULTADO CUANDO
 - $A > 0, B < 0$
 - $A < 0, B > 0$

CODIGOS

(14)

DEFINICION { FORMA DE REPRESENTAR LA INFORMACION CON SIMBOLOS DIFERENTES

CODIGO BINARIO (BCD)

0	0000
1	0001
2	0010
3	0011
4	0100
5	0101
6	0110
7	0111
8	1000
9	1001

* BCD = REPRE. BINARIA
* EJEMPLO

985
1001 1000 0101

49 = 110001₂ = 01001001_{BCD}

* PARA SUMAR
AGREGAR 6 BCD A CADA
RESULTADO QUE SEA INVÁLIDO

```

60 0110 0000
67 0101 0101
-----
1011 0101
  0110
-----
10001 0101 = 115
    
```

* VENTAJAS: REDUCE CONVERSIONES
NECESARIAS E/S

* DESV.: LAS OPERACIONES SON MAS
LENTAS

REPRESENTACION
DE #S DECIMALES

REPRESENTACION
DE CARACTERES

EBCDIC { - Extended Binary Code
International Corporation (IBM)
- 8 BITS/CHAR

ASCII { - American Standard Code for
Information Interchange
- Emplea 7 bits
- Generalmente se agrega 1
bit de paridad (+ signif.)
- Permite representar
128 caract. (may. y min)
95 simbolos graficos
23 formateadores
10 comunicacion y statu.

CHAR ASCII
100 0001
↓
100 1111
↓
101 0000

CHAR ASCII
0 11 0000
↓
011 1001
↓
010 0000
↓
1110
↓
1000
↓
1011
↓
0100
↓
1010
↓
1001
↓
1101
↓
1111
↓
0101100
↓
0111101

26

CIROS DIGITALES BASICOS

LEDO SUMADOR
(HALF ADDER)

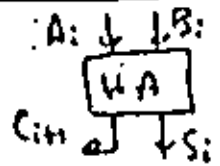

SUMADOR COMPLETO
(FULL ADDER)

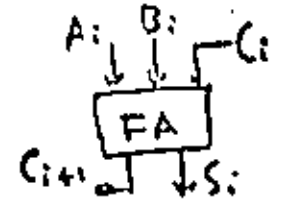

DECODIFICADOR

- CONVIERTE INFORMACION BINARIA DE UN CODIGO A OTRO
- SELECCION DE DISPOSITIVOS

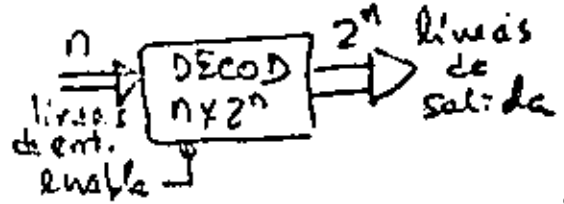

- SOLO UNA LINEA DE SALIDA ADQUIERE VALOR UNITARIO PARA C/COMBINACION DE LAS LINEAS DE ENTRADA
- LOS HAY DE 2x4, 3x8, 4x16, ...
- CON ENABLE SE PUEDEN UNIR DOS PARA GENERAL OTRO DE MAYOR CAPACIDAD

MULTIPLEXION

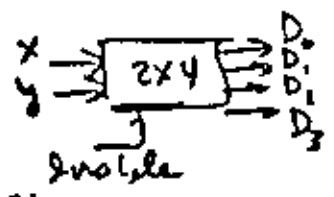

X\Y	D ₀	D ₁	D ₂	D ₃
0\0	1	0	0	0
0\1	0	1	0	0
1\0	0	0	1	0
1\1	0	0	0	1

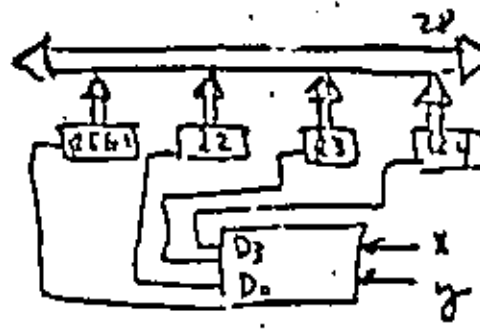
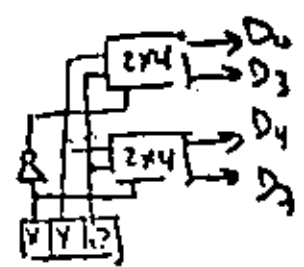

PROBLEMA:

CONSTRUIR UN CIR. CON DECODIF. QUE CONVierta CODIGO BCD EN CODIGO DE 7 SEGMENTOS

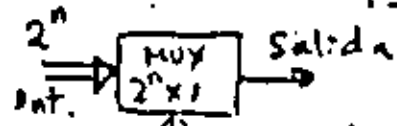
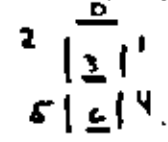

n líneas de selección S₀...

USOS

- SELECC. INFORMACION DE ENTRADA PROVENIENTE DE DIFERENTES REACTIVOS
- MULTIPLEXAR SEÑALES BINARIAS
- CONVERSION PARALELO SERIE
- IMPLEMENTAR FUNCIONES BOOLEANAS

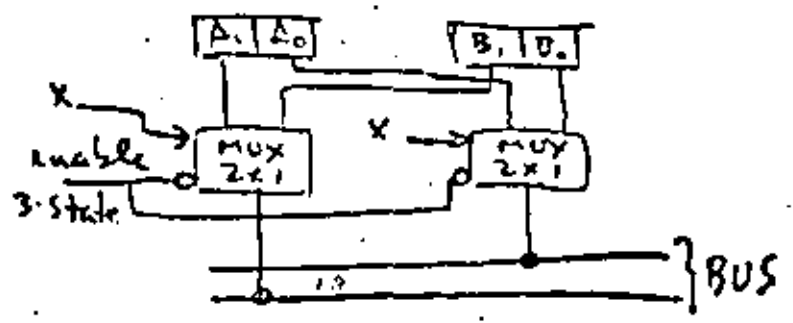

MEMORIAS

- CIRCU. DIGITALES CON MEMORIA
 $Q(t) = f(S, R, Q_{t-1})$

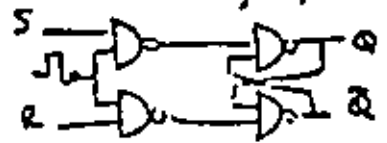

- UNIDAD BASICA DE MEMORIA (1 FLOP = 1 BIT)

FLOP → FLOPS

- TIPOS

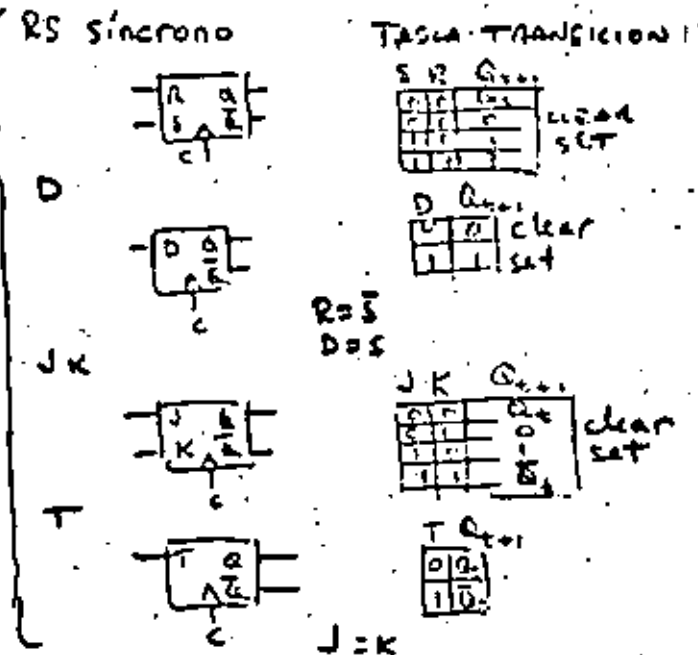

- TABLAS DE EXCITACION

Q_t	Q_{t+1}	S	R
0	0	0	x
0	1	1	0
1	0	0	1
1	1	x	0

Q_t	Q_{t+1}	J	K
0	0	0	x
0	1	1	0
1	0	0	1
1	1	x	0

Q_t	Q_{t+1}	D
0	0	0
0	1	1
1	0	0
1	1	1

Q_t	Q_{t+1}	T
0	0	0
0	1	1
1	0	1
1	1	0

DEFINICION

CONJUNTO DE FC DE ALMACENAMIENTO JUNTA CON LAS CIRCUITOS ASOCIADOS NECESARIOS PARA LA XFERENCIA DE INFORMACION DE E y/o S.

ESTRUCTURA

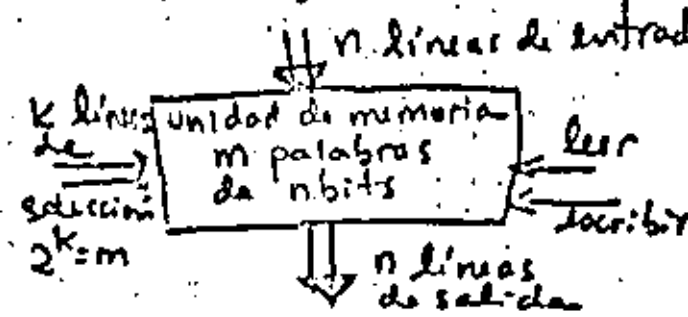

TIPOS (ACCESO ALEATORIO)

CORE

- NUCLEOS MAGNETICOS
- NO VOLATILES
- LENTAS y VOLUMINOSAS.

MOS

- VOLATILES
- RAPIDAS y COMPACTAS
- TIPOS
 - RAM
 - LEEN y ESCRIBIR
 - ESTATICAS
 - DINAMICAS (requiere refresh)
 - ROM
 - LECTURA
 - INFORMACION ES GRABADA POR FABRICANTE
 - PROM
 - LECTURA
 - INFO. LA GRABA EL USUARIO
 - EPROM
 - PROM QUE PUEDE BORRARSE CON UV

PARAMETROS
MÁS
RELEVANTES

TIEMPO DE ACCESO: Tiempo que trans-
corre entre la llegada de la
señal de lectura y que la
información este disponible
a la salida

TIEMPO DE CICLO = TIEMPO DE
ACCESO + TPO. RESTAURACION
PARA CORE.

RAM - 100 ns : 400 ns
CORE - 1 μs

(17)

OPERACIONES
DE
UNA UNIDAD
DE
MEMORIA

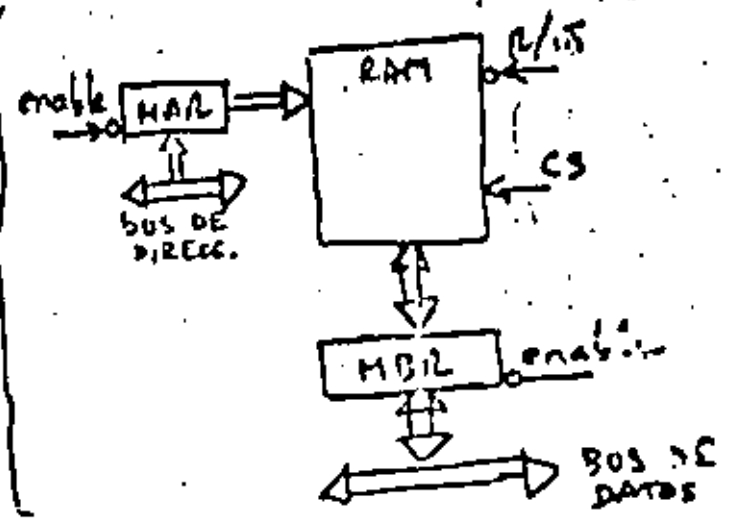

RAM

- TÍPICA: 128 x 8

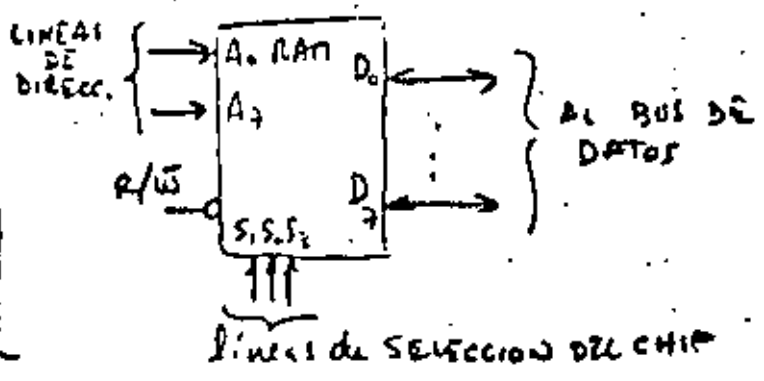

EJEMPLO
DE
CONEXIONES

- DIRECC. DE RAM:
1110 0000 0000 0000 C00012
1110 0000 0111 1111 C07F16

- BUS DE DATOS: 8 BITS
- BUS DE DIRECC.: 16 BITS

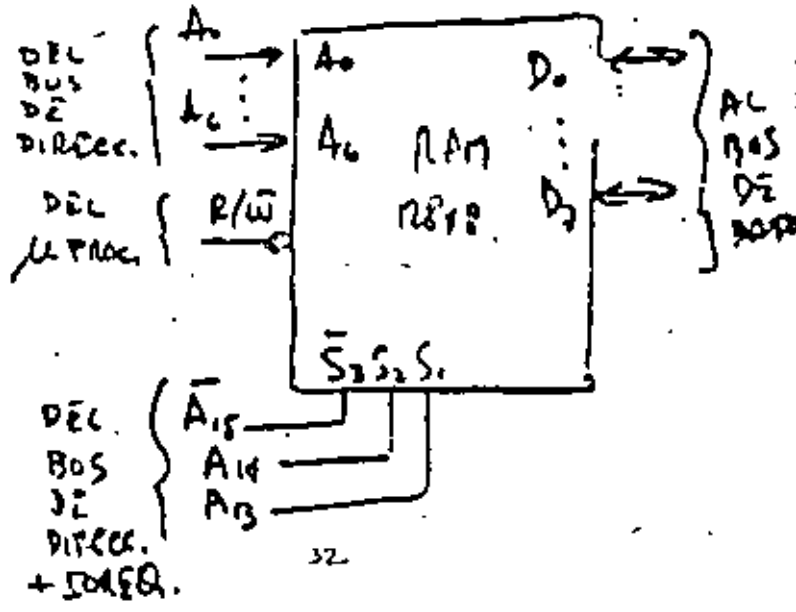

COM

Típica: 1024 x 8

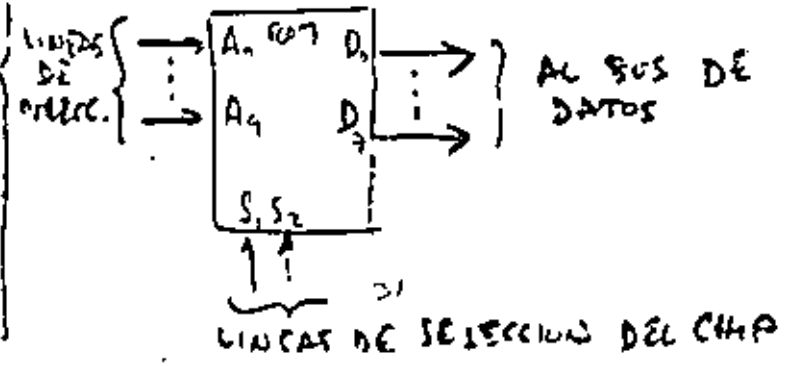

MICROPROCESADOR (MPU)

(18)

- EJECUTA OPERACIONES \leftarrow ARITMETICAS
LOGICAS
CONTROL
- GENERA LAS SEÑALES NECESARIAS PARA ACTIVAR PERIFERICOS Y SINCRONIZAR ACTIVIDADES
- REQUIERE DE UN RELOJ
- GENERA LAS DIRECCIONES
- COORDINA EL PROCESAMIENTO DE LA INFORMACION
- # LINEAS DE DIRECC \sim 16 (TIPICO)
- # LINEAS DE DATOS \sim 8 (TIPICO)
- # LINEAS DE CONTROL \sim VARIABLE

IOBQ
INT
NMI
R/N
ACK
IRQ

- ELEMENTOS

- ALU
- REGISTROS DE PROP. GEN. { A, B, C, D }
- REGISTRO DE STATUS { Z, C, S, P }
- REGISTROS INDICE { DI, SI }
- APUNTAOR DE STACK { SP }
- CONTADOR DE INSTRUCC. { PC }
- REGISTRO DE INSTRUCC. { IR }

CONFIGURACION TIPICA

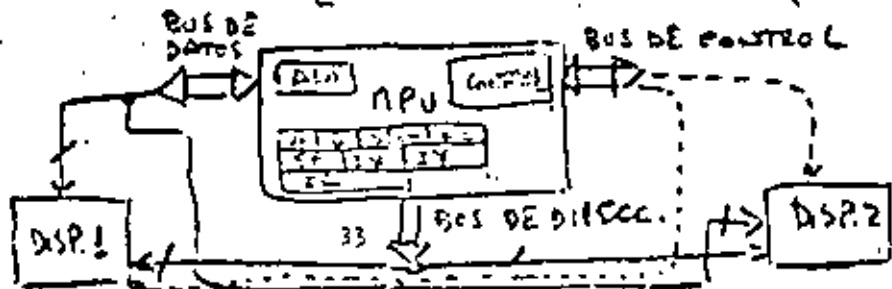
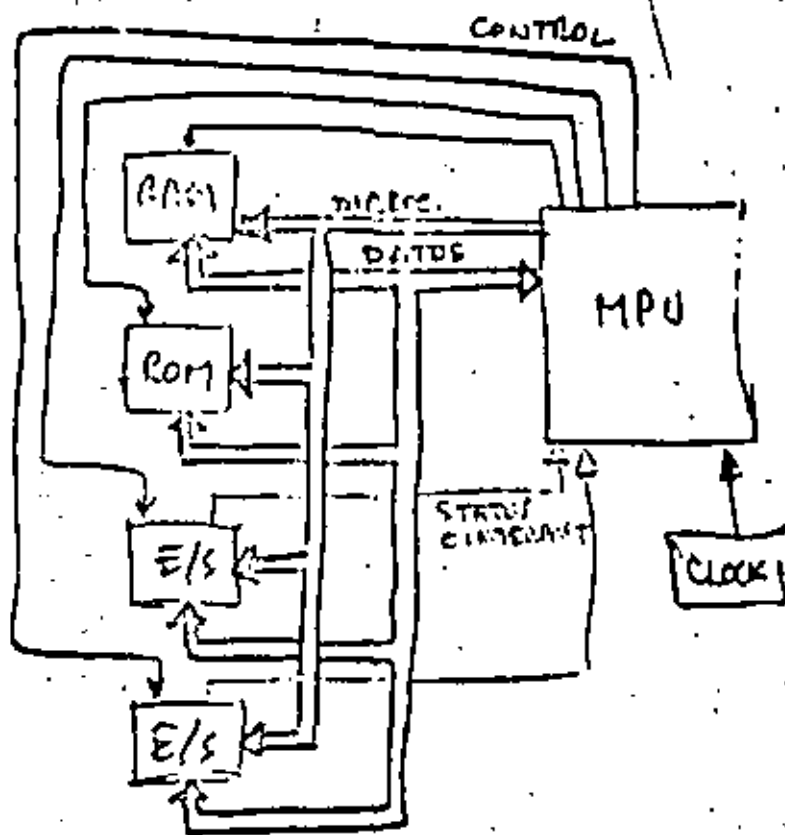

donde T1 y T2 representan localidades temporales usadas para guardar resultados aritméticos intermedios.

Las conclusiones más importantes en este esquema son:

Los programas no necesitan estar almacenados en memoria en forma secuencial ya que el campo de dirección de la siguiente instrucción permite conocer donde fueron almacenados.

Debido a que cada instrucción contiene en forma explícita tres direcciones, no es necesario tener en el CPU hardware para guardar los resultados de las operaciones.

b) Máquinas de "3" direcciones

Considerando que los programas se escriben secuencialmente y que por consiguiente es muy lógico almacenarlos en este mismo orden, se llega a un nuevo esquema de direccionamiento en el cual se sustituyen todos los campos de dirección de la siguiente instrucción por un solo registro dentro del procesador que lleva en forma secuencial y automáticamente la dirección de la siguiente instrucción a ejecutar. Un posible formato de instrucción se muestra en la fig. IV.2 .



FIG. IV.2

Utilizando este esquema de direccionamiento la expresión $A=(B^*C)-(D^*E)$ en FORTRAN, quedaría expresada como:

MUL R, C, T1

MUL D, E, T2

SUB T2, T1, A

Siguiente instrucción

Donde se ha suprimido la dirección de la siguiente instrucción ya que ésta es llevada en forma secuencial y automática por un registro del procesador conocido como contador del programa (PC).

Con el esquema de 3 direcciones se logra aprovechar la memoria en forma más eficiente y reducir la longitud de palabra lo que reduce directamente en los costos de la misma.

c) Máquinas de "2" direcciones.

En las operaciones aritméticas no siempre es necesario guardar el resultado en una localidad de memoria y preservar los operandos, por lo que se puede pensar en utilizar uno de ellos para guardar el resultado una vez que la operación se ha efectuado. Las consideraciones anteriores llevan a presentar un posible formato de instrucción en esta máquina, mostrado en la figura IV.3

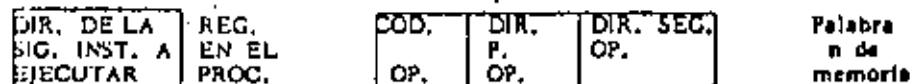

FIG. IV.3

IV. - MODOS DE DIRECCIONAMIENTO

1.- ESQUEMAS DE DIRECCIONAMIENTO.

La unidad central de proceso (CPU) en las computadoras debe realizar las siguientes funciones:

- Obtener y traer de memoria primaria a CPU la siguiente instrucción a ejecutar.
- Entender los operandos, esto es, definir la localización de los operandos necesarios para ejecutar la instrucción y traerlos a CPU.
- Ejecutar la instrucción.

Para llevar a cabo las funciones anteriores el CPU debe contar con la siguiente información:

- El código de operación de la instrucción a ejecutar.
- Las direcciones de los operandos y la del resultado.
- La dirección de la siguiente instrucción a ejecutar.

Existen diferentes soluciones que satisfacen los requerimientos anteriores, los cuales determinan la arquitectura de los procesadores que las utilizan.

Se supondrán operaciones aritméticas en las que se tienen dos operandos y un resultado ya que son las que proporcionan el caso más general.

a) Máquinas de "3+1" direcciones

El formato de instrucción en este esquema de direccionamiento contiene todos los elementos necesarios por el CPU

para realizar sus funciones.

Un posible formato de instrucción se muestra en la figura

IV.1

CÓDIGO DE OPERAC.	DIRECCIÓN PRIMER OPERANDO	DIRECCIÓN SEGUNDO OPERANDO	DIRECCIÓN RESULTADO	DIRECCIÓN DE LA SIGUIENTE INSTRUCCIÓN	Palabra n de memoria
-------------------	---------------------------	----------------------------	---------------------	---------------------------------------	----------------------

FIG. IV.1

En este caso se tienen cinco campos en el formato de instrucción: Uno para el código de operación que sirve para indicar el tipo de operación a realizar (suma, resta, multiplicación, etc.), tres campos para las direcciones de los operandos y resultado de las operaciones, un campo para indicar la dirección de la siguiente instrucción a ejecutar.

Las instrucciones para esta máquina podrían ser escritas en forma simbólica en la siguiente forma: ADD A, B, C, D donde ADD representa el código de operación suma y A, B, C y D son nombres simbólicos asignados a localidades de memoria.

Suponiendo que existen las instrucciones suma (ADD), sustracción (SUB) y multiplicación (MUL), entonces una posible traducción de la expresión $A = (B * C) - (D * E)$ en FORTRAN a lenguaje simbólico en la máquina de 3+1 direcciones sería:

```
L1:  MUL  B, C, T1, L3
L3:  MUL  D, E, T2, L7
L7:  SUB  T2, T1, A, L8
L8:  Siguiete instrucción
```



En este esquema se usará la dirección del segundo operando como la dirección del resultado una vez que la operación se haya efectuado, por lo que el segundo operando será destruido. Así pues la expresión $A=(B \cdot C)-(D \cdot E)$ en FORTRAN, quedaría:

```
MUL B,C
MUL D,E
SUB E,C
ADD C,A
```

La eliminación del campo de dirección del resultado permite reducir la longitud de la palabra de memoria y los costos de la misma, lo que permite usar este esquema en máquinas medianas y chicas.

d) Máquinas de "1" dirección

Este esquema de direccionamiento permite eliminar de todas las instrucciones el campo de dirección de uno de los operandos y sustituirlo por un registro dentro del procesador, el cual contendrá a uno de los operandos. A este registro se le conoce como acumulador. El formato de instrucción para la máquina de 1 dirección se muestra en la figura IV.4

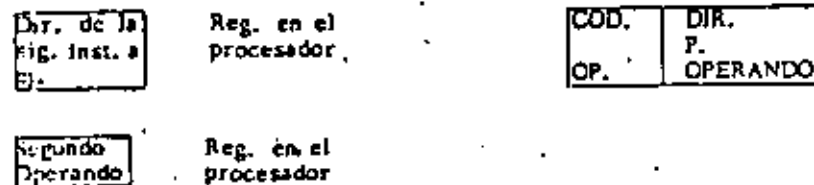

FIG. IV.4

Lo anterior implica la creación de instrucciones que permitan cargar el acumulador con el segundo operando (LAC) y depositar el contenido del acumulador en memoria (DAC).

Es importante hacer notar que todas las operaciones se llevan a cabo implícitamente contra el acumulador y que éste contendrá el resultado de la operación efectuada. La expresión $A=(B \cdot C)-(D \cdot E)$ en FORTRAN, podría traducirse a:

```
LAC D
MUL E
DAC T1
LAC B
MUL C
SUB T1
DAC A
```

Este esquema de direccionamiento ha sido ampliamente implementado en una gran mayoría de las minicomputadoras, como por ejemplo: PDP-8, PDP-15, IBM-1130, IBM-7090 y CDC 3600.

e) Máquinas de "0" direcciones

Este esquema de direccionamiento solo utiliza el campo de código de operación, por lo que es necesario contar con algún mecanismo que implícitamente permita conocer los operandos.

El mecanismo anterior se implementa usando una pila ó stack, el cual se puede pensar como un conjunto de localidades contiguas de

memoria accedidas usando una disciplina UEPS (últimas entradas, primeras salidas). De lo anterior se concluye que en cada momento se tendrá disponible el elemento que se encuentre en el tope del stack.

El formato de instrucción para este esquema de direccionamiento se encuentra en la figura 14.5

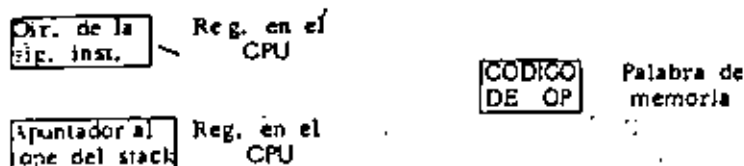
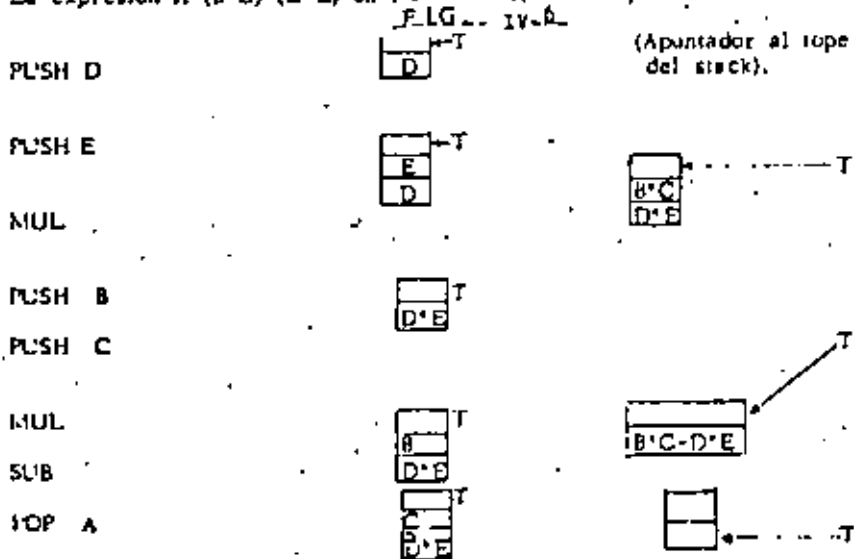

FIG. 14.5

Es necesario contar con instrucciones que permitan meter elementos de memoria al stack (PUSH) y sacar elementos del stack a memoria (POP).

La expresión $A=(B*C)-(D*E)$ en FORTRAN, podría expresarse como:



En la fig. 14.6 se ilustra el estado del stack después de cada una de las inst. anteriores.

Se puede concluir que el conjunto de instrucciones de la máquina no está formado solamente por instrucciones de cero direcciones ya que también se requieren instrucciones de una dirección para meter y sacar elementos al stack.

Se requiere un registro en el procesador que apunte al tope del stack y se elimine el acumulador ya que el resultado de las operaciones también quedará en el stack.

2.- METODOS DE DIRECCIONAMIENTO

En las máquinas de una sola dirección el formato de las instrucciones (que hace referencia a memoria consta de dos campos: el campo de código de operación y el campo de dirección del operando. Si suponemos que el campo de dirección consta de n bits, entonces la máxima capacidad de memoria direccionable será 2^n localidades. Lo anterior puede resultar bastante drástico en el caso de las minicomputadoras ya que por lo general tienen palabras de 12 ó 16 bits y si se asignan cuatro de ellos al campo de código de operación solo se pueden direccionar $2^8 = 256$ localidades de memoria en el caso de palabras de 12 bits ó $2^{12} = 4096$ localidades de memoria en el caso de palabras de 16 bits, lo cual resulta insuficiente para la gran mayoría de las aplicaciones.

Lo anterior ha ocasionado diferentes modos de direccionamiento, en los cuales el campo de dirección sirve para calcular la dirección efectiva del operando, logrando una mayor capacidad de memoria direccionable.

a) Inmediato

En este caso el operando puede estar contenido directamente en el campo de dirección ó en la localidad de memoria siguiente a la instrucción.

Será necesario dedicar un bit de la palabra para saber como se debe interpretar la instrucción.

b) Directo

Existe direccionamiento directo cuando el campo de dirección de la instrucción contiene la dirección del operando ó cuando éste campo combinado con algún registro ó palabra de memoria generan la dirección del operando.

b.1) Usando página cero

Uno de los esquemas más comunes de organización de memoria, divide ésta en n páginas de longitud fija, donde n dependerá del tamaño de la memoria y del tamaño de las páginas.

Las máquinas que usan estos esquemas generalmente usan la página cero con propósitos especiales, como son: manejo de interrupciones, traps, localidades autoincrementables, etc.

La forma de indicar si el contenido del campo de dirección se refiere a la página cero, es usando un bit para este propósito, p. ej. si este bit es cero el campo de dirección apunta a una localidad en la página cero.

b.2) Usando página actual

Si el bit de página está en uno, se asume que el campo de dirección apunta a una localidad en la página en la que se encuentra la instrucción. A esta página se le conoce como

• página actual.

La dirección del operando se determina sumando los bits de orden superior del PC al campo de dirección de la instrucción.

b.3) Relativo al PC

En este modo de direccionamiento el contenido del campo de dirección de la instrucción, interpretado como un entero con signo, se suma al PC para obtener la dirección del operando.

b.4) Relativo a un registro índice

El contenido del campo de dirección de la instrucción, interpretado como un entero con signo, se suma al contenido de un registro índice para obtener la dirección del operando. En caso de existir más de un registro índice es preciso asignar los bits necesarios para su identificación.

c) Indirecto

En el direccionamiento indirecto el campo de dirección de la instrucción contiene un apuntador a la dirección del operando & este campo combinado con algún registro & palabra de memoria genera un apuntador a la dirección del operando.

Mediante un bit en la instrucción se puede saber si el direccionamiento usado es directo & indirecto.

c.1) Usando página cero

El campo de dirección de la instrucción apunta a una localidad en la página cero. A su vez esta localidad contiene la dirección del operando.

c.2) Usando página actual

El campo de dirección de la instrucción apunta a una localidad en la página actual. Esta localidad contiene la dirección del operando.

c.3) Relativo al PC

El contenido del campo de dirección de la instrucción, interpretado como un entero con signo, se suma al PC para obtener la dirección del apuntador al operando.

c.4) Relativo a un registro índice

El contenido del campo de dirección de la instrucción, interpretado como un entero con signo, se suma al contenido de un registro índice para obtener la dirección del apuntador al operando.

La combinación de todos los métodos de direccionamiento anteriores con registros de propósito general, permiten lograr modos de direccionamiento bastante poderosos. Cuando se usan los registros de propósito general, el campo de dirección de la instrucción especifica que registro se usa y como se interpreta la información que contiene.

3.- DIRECCIONAMIENTO EN Z-80

El microprocesador Z-80 es una máquina de una dirección en la que los diferentes modos de direccionamiento son usados por grupos de instrucciones y no se aplican de una forma general a todo el conjunto de instrucciones.

a) Implícito

En este modo de direccionamiento el operando no se define en forma explícita ya que el formato de instrucción es fijo y en los códigos de operación se especifica implícitamente sobre que registros del procesador actúan las instrucciones, por lo que el usuario no puede alterarlo de ninguna manera.

Los grupos de instrucciones, que utilizan este modo de direccionamiento son: carga de 8 bits; carga de 16 bits; intercambio, transferencia de bloques y búsqueda aritméticas de propósito general y control del CPU.

Ejemplos 1.

b) Inmediato

El operando se encuentra en la localidad de memoria siguiente a la instrucción y se considera que forma parte de la misma. Los valores de los operandos inmediatos en ningún caso podrán exceder la capacidad de representación de un byte. Este modo de direccionamiento se utiliza cuando se desean realizar operaciones con valores constantes.

Los grupos de instrucciones que utilizan este modo de direccionamiento son: carga de 8 bits; aritméticas y lógicas de 8 bits y entrada/salida.

Ejemplos 2.

c) Inmediato extendido

El operando se encuentra en los dos bytes (16 bits) siguientes al código de operación de la instrucción. El primer byte contiguo al código de operación es el octeto significativo y el siguiente es el más significativo.

Este modo de direccionamiento es usado por algunas instrucciones de carga de 16 bits.

Ejemplos 3.

d) Registro

El formato de instrucción contiene un campo de dirección de operando donde se especifica cual de los registros del CPU será utilizado como operando.

Los grupos de instrucciones que utilizan este modo de direccionamiento son: carga de 8 bits; carga de 16 bits; aritméticas y lógicas de 8-bits; aritméticas y lógicas de 16 bits; rotaciones y desplazamientos; encendido y apagado de bits; entrada/salida.

Ejemplos 4.

e) Registro indirecto

En este modo de direccionamiento un par de registros (16 bits) contiene la dirección de memoria en la que se encuentra el operando.

Es utilizado por los grupos de instrucciones de carga de 8 bits; intercambio, transferencia de bloques y búsqueda; rotaciones y desplazamientos; prendido y apagado de bits; saltos, llamadas y regreso de subrutinas; entrada/salida.

Ejemplos 5.

f) **Extendido**

La dirección del operando está contenida dentro del campo de operando de la instrucción. El campo de dirección tiene una longitud de 16 bits por lo que la máxima capacidad de memoria direccionable es de 64 K bytes.

Este modo de direccionamiento es utilizado por los grupos de instrucciones de carga de 8 bits; carga de 16 bits; saltos, llamadas y regreso de subrutinas.

Ejemplos 6.

g) **Modificado de página cero**

En este modo de direccionamiento el campo de dirección del operando se refiere a una localidad de memoria dentro de la página cero. Este campo de dirección consta de 3 bits y para su correcta interpretación se multiplica por 0BH, obteniéndose de esta forma la referencia a las localidades decimales.

Este modo de direccionamiento se utiliza exclusivamente por la instrucción RST.

Ejemplos 7.

h) **Relativo**

La dirección del operando se determina sumando al contador del programa el contenido del byte siguiente al código de operación de la instrucción.

El desplazamiento anterior se interpretará como un número en complemento a dos, con lo que se logra un rango de direccionamiento de -126 a +129 localidades relativas al contador del programa.

Este modo de direccionamiento es usado por el grupo de instrucciones de salto, llamada y regreso de subrutinas.

Ejemplos 8.

i) **Indeado**

La dirección del operando se determina sumando al registro de índice especificado el contenido del byte de desplazamiento.

El desplazamiento se interpreta como una cantidad en complemento a dos, con lo que se logra un rango de direccionamiento de -128 a +127 localidades relativas al registro de índice.

Los grupos de instrucciones que utilizan este modo de direccionamiento son: carga de 8 bits; aritméticas y lógicas de 8 bits; rotaciones y desplazamientos; entamado y apagado de bits; saltos, llamada y regreso de subrutinas.

Ejemplos 9.

j) **Bit**

Este modo de direccionamiento permite prender o apagar un bit dentro de un operando seleccionado, usando los modos antes descritos.

Ejemplos 10.

ING. LUIS O. CORDEIRO BOMBIA
AGOSTO-79

Se asumirá que todos los ejemplos siguientes utilizan el sistema de numeración hexadecimal.

Ejemplo 1.

MODOS DE DIRECCIONAMIENTO DEL MICROPROCESADOR 2-ER
PROGRAMA CARGADO EN CASSETE CON EL NOMBRE DE
"CEC"

DIRECCIONAMIENTO IMPLICITO

LD A.P

CARGA EN EL REGISTRO R EL CONTENIDO DEL REGISTRO
DE REFRESCAMIENTO R.

CPL

REALIZA EL COMPLEMENTO LOGICO DEL CONTENIDO DEL
ACUMULADOR Y LO DEJA EN EL MISMO REGISTRO

INC IX

EL CONTENIDO DEL REGISTRO DE INDICE IX SE IN--
CREMENTA EN UNO.

Ejemplo 2.

DIRECCIONAMIENTO INMEDIATO.

ADD A,24H

SUMA AL CONTENIDO DEL REGISTRO ACUMULADOR A EL
DATO 24H Y DEJA EL RESULTADO EN EL MISMO RE--
GISTRO.

AND 30H

REALIZA LA OPERACION LOGICA AND ENTRE EL CONTE--
NIDO DEL REGISTRO A Y EL DATO 30H DEJANDO EL
RESULTADO EN EL MISMO REGISTRO

Ejemplo 3.

0009 F121D028

0000 213F12

DIRECCIONAMIENTO INMEDIATO EXTENDIDO

LD 19,2030H

CARGA EN EL REGISTRO DE INDICE 19 EL DATO 2030H

LD HL,123FH

CARGA EL REGISTRO PAR HL CON EL DATO 123FH

Ejemplo 4.

0010 4F

0011 80

0012 ED52

DIRECCIONAMIENTO DE REGISTRO.

LD C,A

CARGA EL REGISTRO C CON EL CONTENIDO DEL REGIS--
TRO A

ADD A,B

SUMA AL CONTENIDO DEL REGISTRO A EL CONTENIDO
DEL REGISTRO B Y DEJA EL RESULTADO EN EL REGIS--
TRO A.

SBC HL,DE

SUBSTRAE DEL CONTENIDO DEL REGISTRO HL EL CONTE--
NIDO DE LOS REGISTROS DE Y ACUMULADOR CY, DEJANDO
EL RESULTADO EN EL REGISTRO HL

0005 C634

0007 E610

Ejemplo 5.

0014 0A LD R.FEC)

CARGA EL REGISTRO R CON EL CONTENIDO DE LA LOCALIDAD DE MEMORIA R.FEC) POR EL REGISTRO R.FEC)

0015 34 INC (HL)

INCREMENTA EN UNO EL CONTENIDO DE LA LOCALIDAD DE MEMORIA R.FEC) POR EL REGISTRO R.FEC)

0016 22 LD (DE),R

DEPOSITA EL CONTENIDO DEL REGISTRO R EN LA LOCALIDAD DE MEMORIA R.FEC) POR EL REGISTRO R.FEC)

Ejemplo 7.

0017 EF PST OCH

EJECUTA UN SALTO INCONDICIONAL A LA LOCALIDAD DE MEMORIA OCH SIEMPRE DE HACER CUANDO EN EL SÍMBOLO EL CONTENIDO DEL CONTADOR DEL PROGRAMA

Ejemplo 6.

0017 3A2010 LD R,(1020H)

CARGA EL REGISTRO R CON EL CONTENIDO DE LA LOCALIDAD DE MEMORIA 1020H

0018 FD220400 LD (0004H),R

DEPOSITA EL CONTENIDO DEL REGISTRO R EN LAS LOCALIDADES DE MEMORIA 0004H (BYTE DATA) Y 0005H (BYTE ALTO).

Ejemplo 8.

0019 2004 JR Z,25H

SI LA BANDERA Z=1, AL CONTADOR DEL PROGRAMA SE LE SUMA EL VALOR 25H CON LO QUE SE EFECTUARA UN SALTO A LA LOCALIDAD DE MEMORIA 25H

SI LA BANDERA Z=0 SE CONTINUARA EJECUTANDO LA SIGUIENTE INSTRUCCION DEL PROGRAMA

0021 2004 JP (C,17H)

SI LA BANDERA C=1, AL CONTADOR DEL PROGRAMA SE LE SUMA EL VALOR 17H CON LO QUE SE EFECTUARA UN SALTO A LA LOCALIDAD DE MEMORIA 17H

SI LA BANDERA C=0 SE CONTINUARA EJECUTANDO LA SIGUIENTE INSTRUCCION DEL PROGRAMA

Ejemplos 9.

DIRECCIONAMIENTO INDEXADO

0027 FD364313

LD (IX+43H), 13H

EL DESPLAZAMIENTO 43H SE SUMA AL CONTENIDO DEL REGISTRO IX PARA DETERMINAR LA DIRECCION EFECTIVA A DONDE SE DEPOSITARA EL DATO 13H

0027 DD3621

ADD A, (IX+21H)

EL DESPLAZAMIENTO 21H SE SUMA AL CONTENIDO DEL REGISTRO IX PARA DETERMINAR LA DIRECCION DEL OPERANDO, QUE SERA SUMADO AL REGISTRO A EL RESULTADO QUEDA EN EL REGISTRO A

002A DD3487

INC (IX+07H)

EL DESPLAZAMIENTO 07H SE SUMA AL CONTENIDO DEL REGISTRO IX PARA DETERMINAR LA DIRECCION DE LA LOCALIDAD DE MEMORIA CUYO CONTENIDO SE INCREMENTA EN UNO.

Ejemplos 10.

DIRECCIONAMIENTO DE BIT.

002D CBC7

SET 0000H, A

ENCIENDE EL BIT 0 DEL REGISTRO A

002F CB8E

RES 05H, (HL)

APAGA EL BIT 5 DE LA LOCALIDAD DE MEMORIA DIRECCIONADA POR EL REGISTRO HL

Programa de Reloj Digital

Reloj del sistema = 1.9968 Mhz

1.9968 Mhz /256=7800 Hs; contando 200 ciclos por interrupción y 39 -
Interrupciones por segundo para incrementar segundos.

Programa Principal

2000	ED 5E	IM 2	Modo de interrupción 2
	3E 20	LDA, 20	Byte más significativo
	ED 47	LDI, A	Registro I.
	3E 1A	LFA, 1A	Byte menos significativo
	D3 84	OUT (84),A	Canal 0 CTC
	3F A5	LDA,A5	Permitir int. reloj/256
	D3 85	OUT(85),A	Canal 1 CTC
	3E C8	LDA,C8	Constante de tiempo = 200
2010	D3 85	OUT (85), A	
	D8	EXX	Intercambiar registros
	06 27	LDI,39	Número de interrupciones
	D9	EXX	
	FB	EI	Se permiten interrupciones
	01 9F 00	JP RESTART	Monitor despliegue
201A	2020		Vector de interrupción

Programa de servicio de interrupciones

201C			Segundos en BCD
201D			Minutos en BCD
201E			Horas en BCD
2020	08	EX AF,A'F'	Intercambiar registros
	D9	EXX	
	05	DEC B	Contar interrupciones
	20 5C	JR NZ RET	Continuar
	06 27	LD B,27	39 interrupciones por seg.
	1A 1C 20	LD A, (201C)	Segundos
	3C	INC A	
	27	DAA	Ajuste decimal
	FE 60	CP 60	60 segundos.
	38 26	JR C	No
2030	AF	MOR A	SI-borrar A

	12 1C 20	LD (201C),A	
	1A 1D 20	LDA, (201D)	Minutos
	3C	DEC A	
	27	DAA	
	FE 60	CP 60	60 minutos ?
	38 14	JR C	No
	AF	MOR A	SI-borrar A
	32 1D 20	LD (201D),A	
2041	1A 1E 20	LDA, (201E)	Horas
	3C	DEC A	
	27	DAA	
	FE 13	CP 13	13 horas ?
	38 02	JR C	No.
204A	3E 01	LDA,01	
	32 1E 20	LD (201E),A	
	18 08	JR 08	
2051	32 1D 20	LD (201D),A	
	18 03	JR 03	
	12 1C 20	LD (201C),A	
	1A 1C 20	LDA, (201C)	Segundos
	D3 21 FB 23	LD IX,23FB	LED buffer No.3
2060	CD 86 20	CALL DMT	Format para LED buffer
	1A 1D 20	LDA, (201D)	Minutos
	D3 21 F9 23	LD IX, 23F9	LED buffer No. 1
	CD 86 20	CALL DMT	
	1A 1E 20	LDA, (201E)	Horas
2070	D3 21 F7 23	LD IX,23F7	LED buffer No. 1
	CD 86 20	CALL DMT	
	1A 17 23	LDA, (23E7)	LED buffer No. 1-cero ?
	20 05	JR NZ,05	
	3E 10	LDA,10	Apagar LED No. 1
	32 17 23	LD (23F7),A	
2081	08	RST EX AF,A'F'	Intercambiar registros
	D9	EXX	
	FB	EI	Permitir interrupciones
	ED 40	RET	Retorno
2086	4F	RST LD C,A	Subrutina para format
	0E 0F	M0 CF	4 bits menos significativo

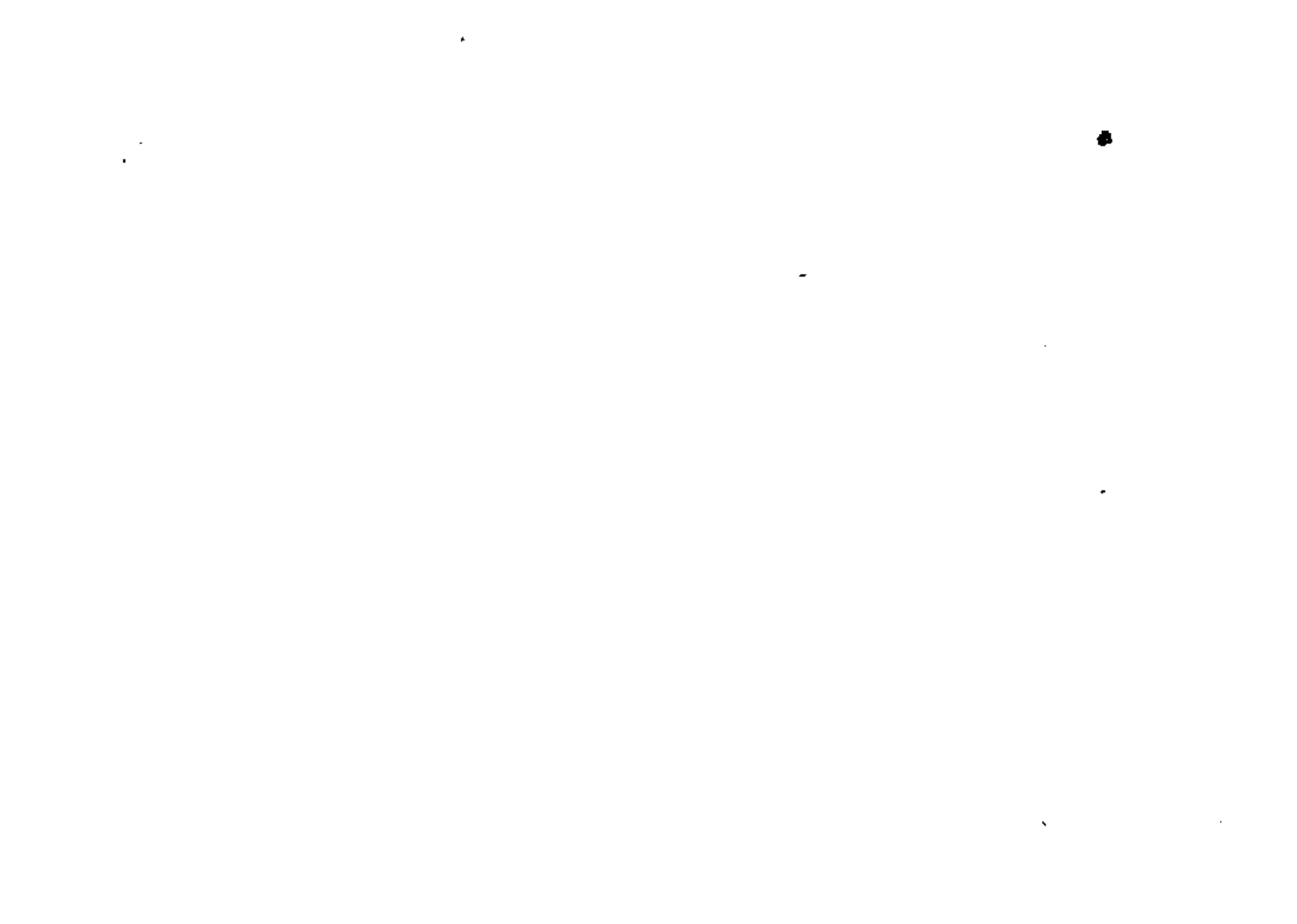

ED 77 01	LD (IX+1),A	LED buffer
CB 39	SRL C	4 bits más significativo
CB 39	SRL C	
2090 CB 39	SRL C	
CB 39	SRL C	
DD 71 00	LD (IX+0),C	LED buffer
CB	RET	Retorno

Programa para Control de un Motor de Paso Superior MS-25

Cuenta Inicial: Registros BC Cuenta Final: Registros DE

Bobinas del motor conectadas a FIG PBO-P33 por amplificador de potencia -
(transistores Darlington).

2000	3E 0F	LEA,OF	Nodo Solido
	D3 83	OUT (03),A	
	62	COMP	
	6B	LD L,E	
	AF	XOR A	Rotar motor
	EO 42	SBC HL,BC	
	FA 11 20	JP 2011	Dirección negativa?
	2B 25	JR 2 STOP	Igual?
	03	INC BC	Positiva
	1B 01	JR D1	
2011	CB	DEC BC	Negativa
	79	LD A,C	Byte menos significativo
	ES 03	AND 03	Dos bits
	62	LD H, D	
	5B	LD L,E	
	5B	EX DE,HL	Guardar cuenta final
	1B 00	LD D,0	
	5F	LD E,A	
	DD 21 39 20	LD IX,TABLA	Rotación de bobinas
	DD 19	ADD IX,DE	Posición en la tabla
2021	DD 7B 00	LD A, (IX+0)	Código de bobinas
	D3 81	OUT (81),A	PTO lado B
	EB	EX DE,HL	Reponer cuenta en DE
	26 01	LD H,1	Byte más significativo
	2E 00	LD L,0	Byte menos significativo
	2D	DEC L	De cinco
	20 ED	JR H,ESP	
	25	DEC H	
	20 EB	JR H,ESP	
2031	1B 01	JR COMP	Otro paso
	AF	STOP	Salida Care
	D3 81	OUT (81),A	
	C3 A5 00	JP NEXT1	Retorno al monitor
2039	CA 06 05 09 TABLA		

Programa para Contar Interrupciones

Interrupciones: pulso hacia arriba en ASTRO. Despliega número 1-99 en los LEDs.

2200	ED 5E	IN 7	
	1E F8	LDA F8	Byte menos significativo
	D3 82	OUT (82),A	del vector de inter.
	3E 4F	LDA, 4F	Modo entradas
	D3 82	OUT(82),A	Lado A control
	3E 87	LDA, 87	Se. permiten interrupciones
	D3 82	OUT (82),A	
	3E 07	LDA, 07	Byte más significativo
2210	ED 47	LDI,A	en registro I
	FB	EI	MPU acepta interrupciones
	C3 9F 00	JP RESTAR	Retorno al monitor
0778	D6 23		Vector en ROM
2306	C3 20 22	JP 2228	
2220	08	EX AP,A'P'	Intercambiar registros
	D9	EDX	
	3A FC 23	LDA, (DISMEM + 3)	LED Buffer No. 6
	E6 0F	AND 0F	
	3C	INC A	
	FE 0A	CP A	Diez o más?
	38 0F	JR C, CONT	No.
	AF	XOR A	SI- borrar A
	32 FC 23	LD(DISMEM + 3),A	
2230	3A FB 23	LDA, (DISMEM + 4)	Incrementar 10's
	E6 0F	AND 0F	
	3C	INC A	
	32 FB 23	LD(DISMEM + 4),A	
	18 03	JR 03	
	32 FC 23	LD(DISMEM + 5),A	
	21 00 80	LD HL,8000	Esperar desconexión
2241	20	ESP DEC L	
	20 FD	JR NZ ESP	

25
20 FA
08
D9
FB
ED 4D

DEC H
JR NZ ESP
EX AP,A' P'
EDX
EI
RPL

Reponer registros

Permitir interrupciones

Retorno

Programa para contar frecuencia de una señal externa con CTC

Contar ondas en Canal 1 CLK/TRG por 1/10 seg. usando canal 3 con 4 interrupciones,
cada una de $195 \times 256 / 1.9968 \times 10^6 = .025$ seg.
Para probarlo, usar canal 0 salido ZC.

Programa Principal

2060	3E 05	LDA,05	Reloj /16, no interrup.
	D3 84	OUT(84),A	Canal 0
	3E 80	LDA,80	128*16, ciclos =975 Hz
	D3 84	OUT (84),A	
2068	ED 5E	IN 2	
	3E 20	LDA,20	Byte más significativo
	ED 47	LDI,A	Registro I
	3E 88	LDA,88	Byte menos significativo
2070	D3 84	OUT (84),A	Se escribe en canal 0
	3E A5	LDA,A5	Reloj/256, permitir int..
	D3 87	OUT (87),A	Canal 3
	3E C3	LDA,C3	Constanta de tiempo = 195
	D3 87	OUT (87),A	
	3E 55	LDA,55	Modo contador, no int.
	D3 85	OUT (85),A	Canal 1
	AF	XOR A	Borrar A
	D3 85	OUT (85),A	Constanta de tiempo
2081	32 FC 23	LD (DISMEM +5),A	Cero en LED No. 4
	D9	EOX	Cargar registros altern.
	0E 00	LDC,00	Cuenta inicial
	06 04	LD B,04	Cuatro interrupciones
	D9	EOX	
	FB	EI	Permitir interrupciones
	C3 F4 00	JP DISUP	Monitor despliegue
208E	90 20		Vector de int. canal 3

Programa de servicio de interrupciones

2090	08	EX AF,A'P'	
	D9	EOX	
	05	DEC B	Contar interrupciones
	20 41	JR NZ RET	
	06 04	LD B, 04	

	D8 85	IN A, (85)	Cuenta nueva
	5F	LD E, A	Guardar en E
	57	LD D, A	Contar con D
	AF	XOR A	Borrar A y DISMEM
	32 F9 23	LD (DISMEM +2),A	
	32 FA 23	LD (DISMEM +3),A	
20A2	32 FB 23	LD (DISMEM +4),A	
	18 2A	JR CPHR	
	1A FB 23	LD A, (DISMEM +4)	
	3C	INC A	
	FE 0A	CP A	¿Más o mayor?
	38 1E	JR C	No. — continuar
	AF	XOR A	SI — borrar A
20B0	32 FB 23	LD (DISMEM +4),A	
20B1	1A FA 23	LD A, (DISMEM +3)	
	1C	INC A	
	FE 0A	CP A	¿Más o mayor?
	18 0D	JR C	No — continuar
	AF	XOR A	SI — borrar A
	32 FA 23	LD (DISMEM +3),A	
	1A F9 23	LD A, (DISMEM +2)	
20C2	3C	INC A	
	32 F9 23	LD (DISMEM +2),A	
	18 08	JR 08	
	32 FA 23	LD(DISMEM +3),A	
	18 03	JR 03	
	32 FB 23	LD (DISMEM +4),A	
20D0	14	INC D	
	7A	CHPR	
	B9	CF C	Igual a cuenta previa?
	20 D2	JR NZ,REPT	Repetir
	48	LD C,E	Guardar nueva cuenta
	08	RET	Intercambiar registros
	D9	EOX	
	FB	EI	Permitir interrupciones
	ED 4D	RTI	Retorno

Programa para Síntesis de Música con I-80 Starter Kit

Salida: onda cuadrada en U14 pata 2 proveniente del CTC canal 1.
 La melodía se almacena en una tabla de frecuencias (periodos de tonos - en unidades de 16 micro segundos) y duraciones en unidades de 13 microsegundos. Una frecuencia de 00 en la tabla indica silencio.

Programa Principal

2200	21 04 22	COM LD HL, TABLA	Dirección de la tabla
	7E	RECOM LD A, (HL)	Nota
	B7	OR A	Comprobar para cero
	CE 20 22	CALL Z, SILEN	
	C4 28 22	CALL NZ, NOTA	
	23	DA: HL	
	B6	LD D, (HL)	Duración
	CD 30 22	CALL ESP	Subrutina de espera
2210	CD 20 22	CALL SILEN	Pausa entre notas
	16 01	LD D, 01	
	CD 30 22	CALL ESP	
	23	DE: HL	Siguiente nota
	18 EH	JR RECOM	

Subrutina de silencio

2220	3E 03	SILEN LD A, 03	Apagar CTC
	D3 B5	OUT (B5), A	Canal 1
	AF	XOR A	Respetar con cero
	C9	RET	Retorno

Subrutina de Nota

2228	3E 05	NOTA LD A, 05	Dividir por 16
	D3 B5	OUT (B5), A	Canal 1
	7E	LD A, (HL)	Sacar período
	D3 B5	OUT (B5), A	
	C9	RET	Retorno

Subrutina de Espera

2230	06 10	ESP LD B, 10	16 veces por el bucle
	1E 00	LD E, 00	
	3D	BUCLE DEC E	
	70 FD	JR NZ BUCLE	
	10 FB	DJNZ BUCLE	Registro B
	15	DEC D	Dirección de la tabla
	2D F4	JR NZ ESP	
	C9	RET	Retorno

Tabla de la melodía

2240 9F 04 05 04 05 04 C8 08 05 10 A9 08 FF 10 00 00 00 00

Programa para Salida Audio -- PIO PAD440 Hz (ω) = 1.13636 meg. por 1/2 ciclo

Reloj del Starter Kit = 1.9958 MHz

2269.1 ciclos = 1.13636 meg.

2260	JZ CF	LDA OP	Modo de salidas
	D3 82	OUT (82),A	Canal A control
	A*	XOR A	Registro A = 0
	D3 80	REP OUT(80),A	Canal A datos
	06 8C	LD B,8C	140 veces por el bucle
	05	DEC B	
	20 FD	JR NZ	
	3C	INC A	Cambiar bit 0
	18 FC	JR REP	

Cuenta : $16 \cdot 139 + 11 + 11 + 7 + 4 + 12 = 2269$ ciclos.Programa para Salida Audio -- CTC Canal 1

Starter Kit 2C1 = pata 8 del CTC = pulso (1 microseg.) a 878.9

Hz con constante de tiempo de $147 \cdot 16 = 2272$ ciclos del reloj. U14 pata

3= onda cuadrada a 439.4Hz.

2270	JE 05	LDA,05	Timer modo, $\frac{1}{2}$ 16, no int.
	D3 85	OUT(85),A	Canal 1 control
	3E 8E	LDA,8E	Constante de tiempo
	D3 85	OUT(85),A	
	C3 F4 00	JP 00F4	Retorno al monitor

Programa para contar ángulos usando convertidor incrementalRutina de servicio de interrupciones

2000	08	EX AF, A'P'	Interrupción lado A
	D8 81	IN A, (81)	Leer lado B
	18 03	JR 03	
2003	08	EX AF, A'P'	Interrupción lado B
	D8 80	IN A, (80)	Leer lado A
	D9	EXX	Guardar registros
	E6 C0	AND C0	Examinar bits 6,7
	B0	CP B	Se valor previo
	FA 1420	JP N 2014	Negativo ?
	28 09	JR Z	Cero?
2011	13	INC DE	Ajustar ángulo +
	18 D1	JR 01	
2014	18	DEC DE	Ajustar ángulo -
	47	LD B,A	Guardar bits 6,7
	ED 53 9C 20	LD(209C),DE	Guardar ángulos
	08	EX AF, A'P'	Intercambiar registros
	D9	EXX	
	FB	EI	Permitir interrupciones
	ED 40	RETI	Retorno

Programa Principal

2020	ED 5E	LD 2	
	3E 98	LDA,98	Byte marca significativo

	LD 82	OUT(R2),A	Vector lado A				
	3E 9A	LDA, 9A			DD 7E 00	LD A, (IX+0)	Código de segmentos
	D3 83	OUT (D3),A	Vector lado B	2080	D3 88	OUT (SECH),A	LED segmentos
	3E 4F	LDA, 4F	Modo entradas		78	LD A, B	B índice LED número
	D3 82	OUT(R2),A	Lado A		D3 8C	OUT (DIGH),A	LED catódo
	D3 81	OUT(R1),A	Lado B		1E 2D	LD E, 2D	0.6 sec. espera
2030	3E 87	LDA, 87	Permitir interrupciones		1D	DEC E	
	D3 82	OUT(R2),A	Lado A		3E 00	LD A, 0	
	D3 83	OUT(R3),A	Lado B		BB	CP E	
	3E 20	LDA, 20	Byte más significativo		20 FA	JR 1E	
	ED 47	LDA, A	Registro 1		3E 01	LD A, 01	
	FB	EI	Permitir interrupciones		58	CP B	Terminado?
	DD 21 AD 20 EMT	LD IX, 20AD	LED buffer	2090	28 A9	JR 2, FMT	Recomenzar
	3A 9D 20	LD A, (209D)	Byte más significativo		23	INC 1E	Continuar
2042	F6 0F	AND 0F	4 bits menos signif.		CB 38	SRL B	Siguiente LED
	LD 77 01	LD (IX+1),A			18 09	JR DES	
	3A 9D 20	LD A, (209D)			00		
2044	CB 3F	SRL A	Correr bits 4-7	2098	00 2D		PUNTO A VECTOR
	CB 3F	SRL A		209A	05 20		PUNTO B VECTOR
	CB 3F	SRL A					
2050	CB 3F	SRL A					
	LD 77 00	LD (IX),A	4 bits más significativo				
	3A 9C 20	LDA, (209C)	Byte menos significativo				
	E6 0F	AND 0F					
	LD 77 03	LD (IX+3),A	Bits menos significativo				
	3A 9C 20	LDA, (209C)					
2060	CB 3F	SRL A					
	CB 3F	SRL A					
	CB 3F	SRL A					
	CB 3F	SRL A					
	LD 77 02	LD (IX+2),A	4 bits más signif.				
	21 AD 20	LD HL, 20AD	LED buffer				
	06 04	LD B, 04	LED No. 3				
2070	5E DES	LD E, (HL)					
	16 00	LD D, 0					
	3E 00	LD A, 0					
	D3 8C	OUT (DIGH),A	Apagar LEDs				
	LD 21 A6 07	LD IX, 07A6	Tabla de segmentos				
	D3 19	AND IX, DE	Posición en la tabla				

Z80™-PIO Z80™A-PIO

Product Specification

The Zilog Z-80 product line is a complete set of micro-computer components, development systems and support software. The Z-80 microcomputer component set includes all of the circuits necessary to build high-performance microcomputer systems with virtually no other logic and a minimum number of low cost standard memory elements.

The Z-80 Parallel I/O (PIO) Interface Controller is a programmable, two port device which provides TTL compatible interfacing between peripheral devices and the Z80-CPU. The Z80-CPU configures the Z80-PIO to interface with standard peripheral devices such as tape punches, printers, keyboards, etc.

Structure

- N-Channel Silicon Gate Depletion Load technology
- 40 Pin DIP
- Single 5 volt supply
- Single phase 5 volt clock
- Two independent 8-bit bidirectional peripheral interface ports with "handshake" data transfer control

Features

- Interrupt driven "handshake" for fast response
- Any one of the following modes of operation may be selected for either port:
 - Byte output
 - Byte input

Byte bidirectional bus (available on Port A only)
Bit Mode

- Programmable interrupts on peripheral status conditions.
- Daisy chain priority interrupt logic included to provide for automatic interrupt vectoring without external logic.
- Eight outputs are capable of driving Darlington transistors.
- All inputs and outputs fully TTL compatible.

PIO Architecture

A block diagram of the Z80-PIO is shown in figure 1. The internal structure of the Z80-PIO consists of a Z80-CPU-bus interface, internal control logic, Port A I/O logic, Port B I/O logic, and interrupt control logic. A typical application might use Port A as the data transfer channel and Port B for the status and control monitoring.

The Port I/O logic is composed of 6 registers with "handshake" control logic as shown in figure 2. The registers include: an 8-bit input register, an 8-bit output register, a 2-bit mode control register, an 8-bit mask register, an 8-bit input/output select register, and a 2-bit mask control register. The last three registers are used only when the port has been programmed to operate in the bit mode.

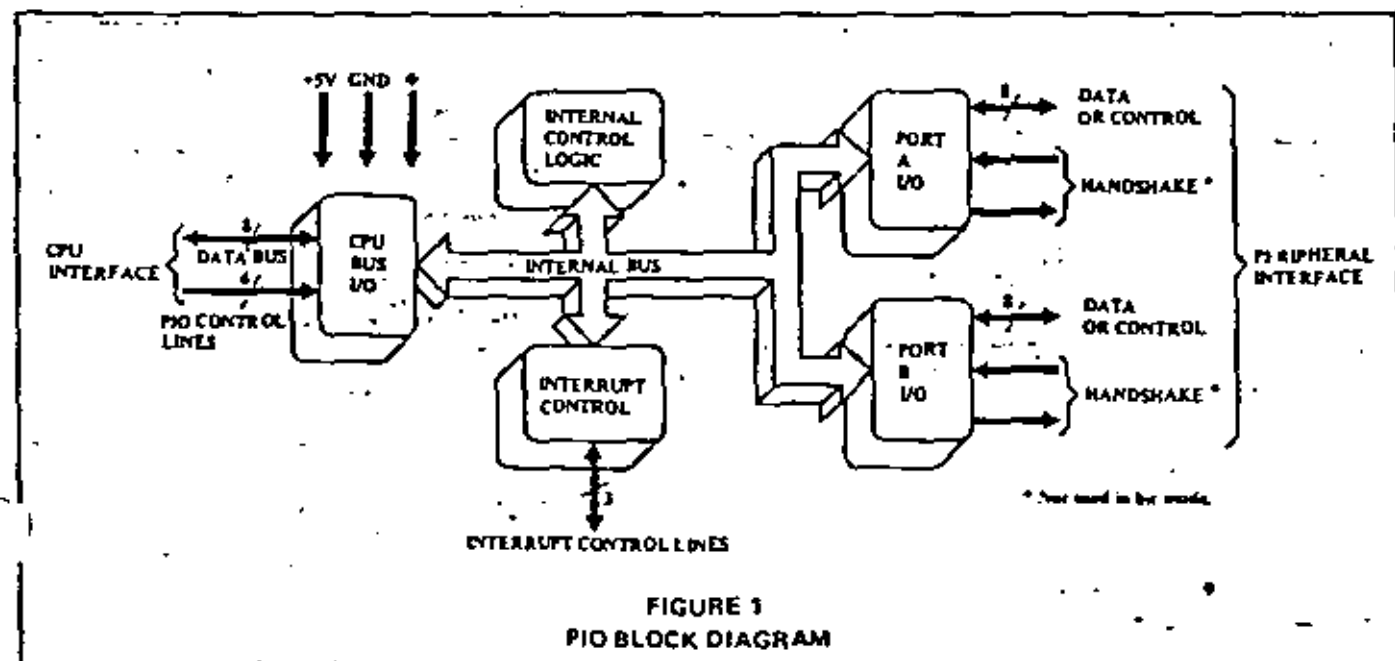

FIGURE 1
PIO BLOCK DIAGRAM

Mode Control Register—2 bits, loaded by CPU to select the operating mode: byte output, byte input, byte bidirectional bus or bit mode.

Data Output Register—8 bits, permits data to be transferred from the CPU to the peripheral.

Data Input Register—8 bits, accepts data from the peripheral for transfer to the CPU.

Mask Control Register—2 bits, loaded by the CPU to specify the active state (high or low) of any peripheral device

interface pins that are to be monitored and, if an interrupt should be generated when all unmasked pins are active (AND condition) or, when any unmasked pin is active (OR condition).

Mask Register—8 bits, loaded by the CPU to determine which peripheral device interface pins are to be monitored for the specified status condition.

Input/Output Select Register—8 bits, loaded by the CPU to allow any pin to be an output or an input during bit mode operation.

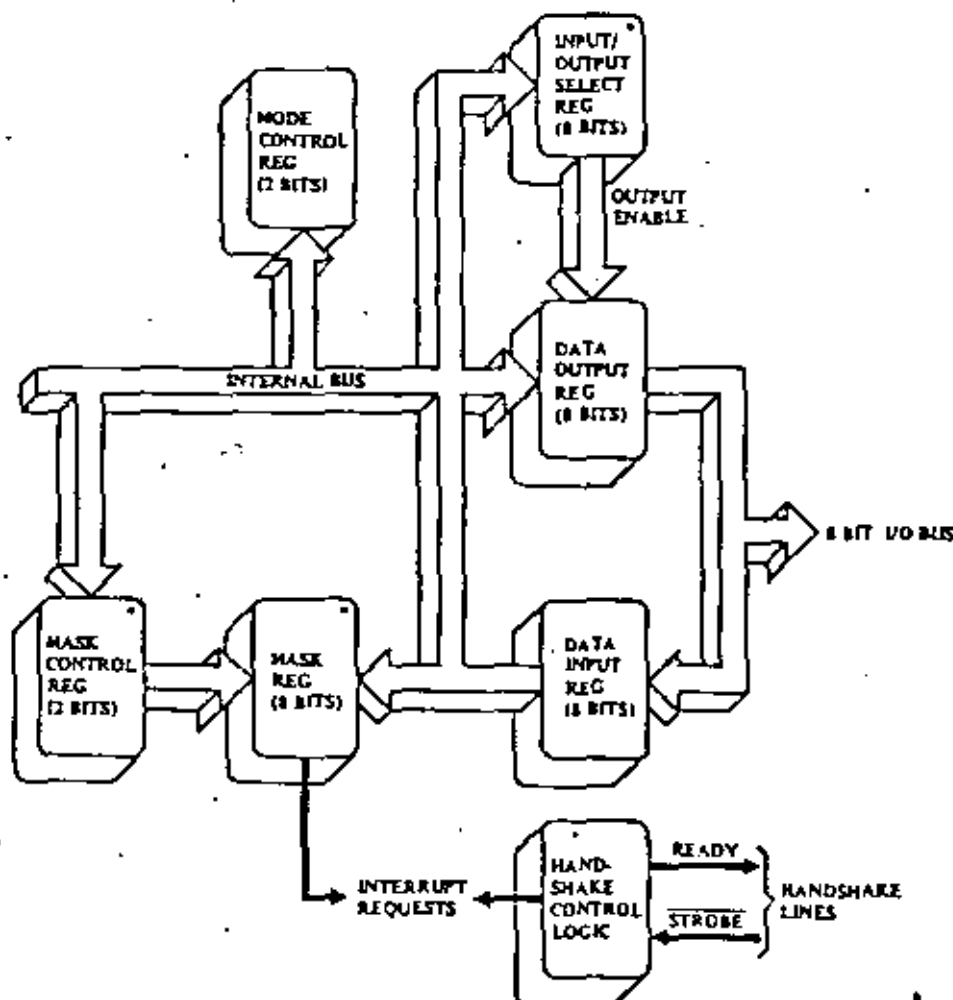

* Used in the bit mode only to allow generation of an interrupt if the peripheral I/O pins go to the specified state.

FIGURE 2
A TYPICAL PORT I/O BLOCK DIAGRAM

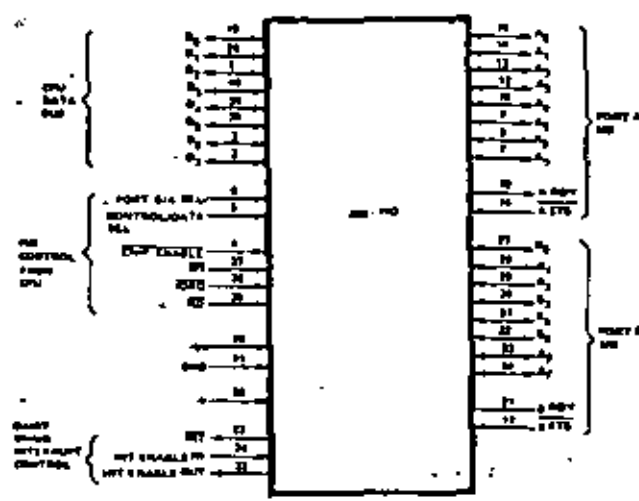

- D₇-D₀ Z80-CPU Data Bus (bidirectional, tristate)
- B/A Sel Port B or A Select (input, active high)
- C/D Sel Control or Data Select (input, active high)
- \overline{CE} Chip Enable (input, active low)
- Φ System Clock (input)

- $\overline{M1}$ Machine Cycle One Signal from CPU (input, active low)
- \overline{IORQ} Input/Output Request from Z80-CPU (input, active low)
- \overline{RD} Read Cycle Status from the Z80-CPU (input, active low)
- IEI Interrupt Enable In (input, active high)
- IEO Interrupt Enable Out (output, active high). IEI and IEO form a daisy chain connection for priority interrupt control.
- \overline{INT} Interrupt Request (output, open drain, active low)
- A₀-A₇ Port A Bus (bidirectional, tristate)
- A STB Port A Strobe Pulse from Peripheral Device (input, active low)
- A RDY Register A Ready (output, active high)
- B₀-B₇ Port B Bus (bidirectional, tristate)
- B STB Port B Strobe Pulse from Peripheral Device (input, active low)
- B RDY Register B Ready (output, active high)

Timing Waveforms

OUTPUT MODE

An output cycle is always started by the execution of an output instruction by the CPU. The \overline{WR} pulse from the CPU latches the data from the CPU data bus into the selected port's output register. The write pulse sets the ready flag after a low going edge of Φ , indicating data is available. Ready stays active until the positive edge of the strobe line is received indicating that data was taken by the peripheral. The positive edge of the strobe pulse generates an \overline{INT} if the interrupt enable flip flop has been set and if this device has the highest priority.

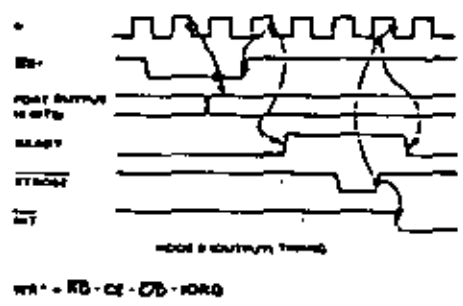

INPUT MODE

When \overline{STROBE} goes low data is loaded into the selected port input register. The next rising edge of strobe activates \overline{INT} if interrupt enable is set and this is the highest priority requesting device. The following falling edge of Φ resets Ready to an inactive state, indicating that the input register is full and cannot accept any more data until the CPU completes a read. When a read is complete the positive edge of \overline{RD} will set Ready at the next low going transition of Φ . At this time new data can be loaded into the PIO.

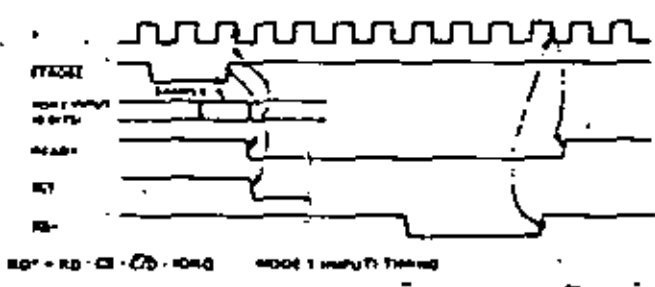

BIDIRECTIONAL MODE

This is a combination of modes 0 and 1 using all four handshake lines and the 8 Port A I/O lines. Port B must be set to the Bit Mode. The Port A handshake lines are used for output control and the Port B lines are used for input control. Data is allowed out onto the Port A bus only when A STB is low. The rising edge of this strobe can be used to latch the data into the peripheral.

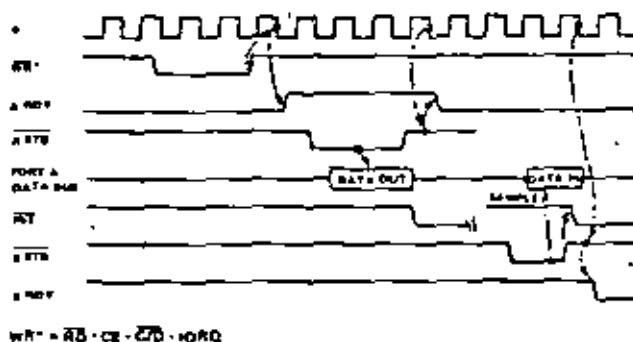

BIT MODE

The bit mode does not utilize the handshake signals and a normal port write or port read can be executed at any time. When writing, the data will be latched into the output registers with the same timing as the output mode.

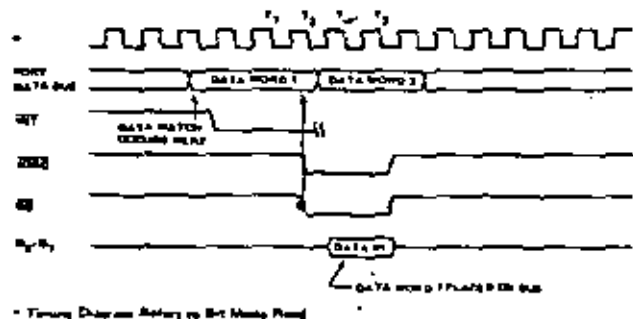

When reading the PIO, the data returned to the CPU will be composed of output register data from those port data lines assigned as outputs and input register data from those port data lines assigned as inputs. The input register will contain data which was present immediately prior to the falling edge of RD. An interrupt will be generated if interrupts from the port are enabled and the data on the port data lines satisfy the logical equation defined by the 8-bit mask and 2-bit mask control registers.

INTERRUPT ACKNOWLEDGE

During MI time, peripheral controllers are inhibited from changing their interrupt enable status, permitting the INT Enable signal to ripple through the daisy chain. The peripheral with IEI high and IEO low during INTA will place a preprogrammed 8-bit interrupt vector on the data bus at this time. IEO is held low until a return from interrupt (RETI) instruction is executed by the CPU while IEI is high. The 2-byte RETI instruction is decoded internally by the PIO for this purpose.

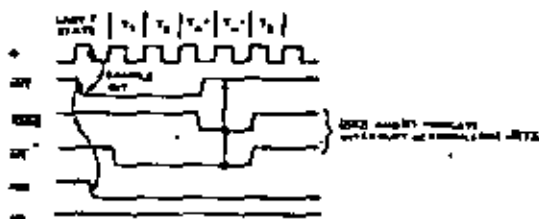

RETURN FROM INTERRUPT CYCLE

If a Z80 peripheral device has no interrupt pending and is not under service, then its IEO=IEI. If it has an interrupt under service (i.e., it has already interrupted and received an interrupt acknowledge) then its IEO is always low, inhibiting lower priority chips from interrupting. If it has an interrupt pending which has not yet been acknowledged, IEO will be low unless an "ED" is decoded as the first byte of a two byte opcode. In this case, IEO will go high until the next opcode byte is decoded, whereupon it will again go low. If the second byte of the opcode was a "4D" then the opcode was an RETI instruction.

After an "ED" opcode is decoded, only the peripheral device which has interrupted and is currently under service will have its IEI high and its IEO low. This device is the highest priority device in the daisy chain which has received an interrupt acknowledge. All other peripherals have IEO. If the next opcode byte decoded is "4D", this peripheral device will reset its "interrupt under service" condition.

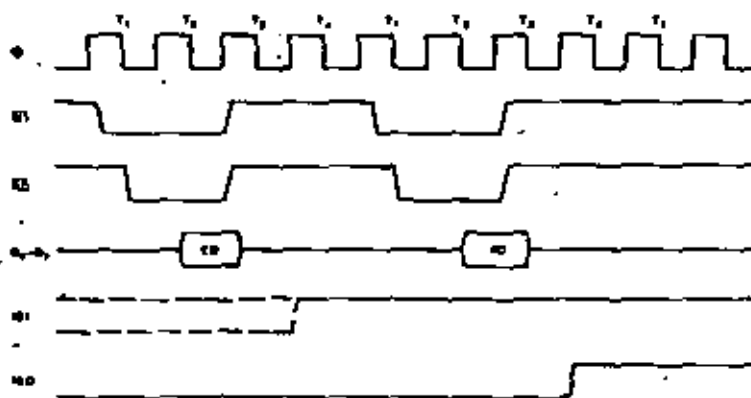

OAD INTERRUPT VECTOR

The Z80-CPU requires an 8-bit interrupt vector be supplied by the interrupting device. The CPU forms the address for the interrupt service routine of the port using this vector. During an interrupt acknowledge cycle the vector is placed on the Z-80 data bus by the highest priority device requesting service at that time. The desired interrupt vector is loaded into the PIO by writing a control word to the desired port of the PIO with the following format:

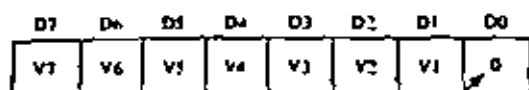

signifies this control word is an interrupt vector

INTERRUPT CONTROL

- Bit 7 = 1 interrupt enable is set—allowing interrupt to be generated.
- Bit 7 = 0 indicates the enable flag is reset and interrupts may not be generated.
- Bits 6, 5, 4 are used in the bit mode interrupt operations; otherwise they are disregarded.
- Bits 3, 2, 1, 0 signify that this command word is an interrupt control word.

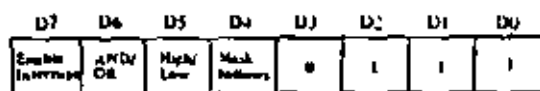

used in Mode 3 only signifies interrupt control word

If the "mask follows" bit is high (D4 = 1), the next control word written to the port must be the mask.

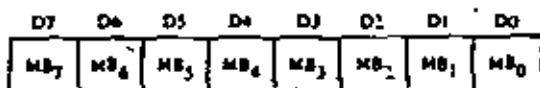

Only those port lines whose mask bit is a 0 will be monitored for generating an interrupt.

The interrupt enable flip-flop of a port may be set or reset without modifying the rest of the interrupt control word by the following command.

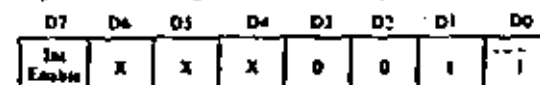

SELECTING AN OPERATING MODE

When selecting an operating mode, the 2-bit mode control register is set to one of four values. These two bits are the most significant bits of the register, bits 7 and 6; bits 5 and 4 are not used while bits 3 through 0 are all set to 1111 to indicate "set mode."

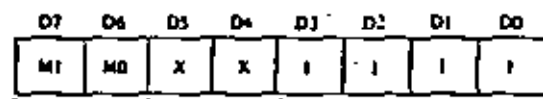

mode word

signifies mode word to be set

X = unused bit

Mode	M ₁	M ₀
Output	0	0
Input	0	1
Bidirectional	1	0
Bit	1	1

MODE 0 active indicates that data is to be written from the CPU to the peripheral.

MODE 1 active indicates that data is to be read from the peripheral to the CPU.

MODE 2 allows data to be written to or read from the peripheral device.

MODE 3 is intended for status and control applications. When selected, the next control word must set the I/O Register to indicate which lines are to be input and which lines are to be output.

I/O = 1 sets bit to input.

I/O = 0 sets bit to output.

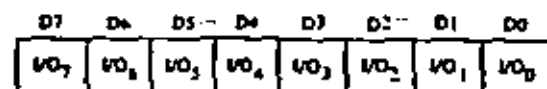

TA = 0° C to 70° C, Vcc = +5 V ± 5%, unless otherwise noted

SIGNAL	SYMBOL	PARAMETER	MIN	MAX	UNIT	COMMENTS
φ	t _{CP}	Clock Period	400	(1)	ns	
	t _{PH} (PH)	Clock Pulse Width, Clock High	170	2000	ns	
	t _{PL} (PL)	Clock Pulse Width, Clock Low	170	2000	ns	
	t _{RI}	Clock Rise and Fall Times		20	ns	
	t _{CH}	Any Hold Time for Successful Set-Up Time	0		ns	
CS, CE ETC.	t _{SE} (CS)	Control Signal Set-Up Time to Rising Edge of φ During Read or Write Cycle	280		ns	
D ₀ -D ₇	t _{OD} (D)	Data Output Delay from Falling Edge of RD		430	ns	(2)
	t _{SO} (D)	Data Set-Up Time to Rising Edge of φ During Write to MT Cycle	80		ns	(2)
	t _{OD} (D)	Data Output Delay from Falling Edge of RD during INTA Cycle		340	ns	(2)
	t _{FL} (D)	Delay to Floating Bus (Output Buffer Disables Times)		180	ns	
IE1	t _{SE} (IE1)	IE1 Set-Up Time to Falling Edge of RD during INTA Cycle	140		ns	
IE0	t _{OH} (IE1)	IE0 Delay Time from Rising Edge of IE1		210	ns	(3)
	t _{OL} (IE1)	IE0 Delay Time from Falling Edge of IE1		190	ns	(3)
	t _{OH} (MT)	IE0 Delay from Falling Edge of MT (Interrupt Occurring Just Prior to MT) See Note A.		300	ns	(3)
IORQ	t _{SE} (IR)	IORQ Set-Up Time to Rising Edge of φ During Read or Write Cycle	280		ns	
MT	t _{SE} (MT)	MT Set-Up Time to Rising Edge of φ During INTA or MT Cycle. See Note B.	210		ns	
RD	t _{SE} (RD)	RD Set-Up Time to Rising Edge of φ During Read or MT Cycle	340		ns	
A ₀ -A ₇ , B ₀ -B ₇	t _{SE} (PD)	Port Data Set-Up Time to Rising Edge of STROBE (Mode 1)	280		ns	(4)
	t _{SO} (PD)	Port Data Output Delay from Falling Edge of STROBE (Mode 2)		230	ns	(4)
	t _{FL} (PD)	Delay to Floating Port Data Bus from Rising Edge of STROBE (Mode 2)		200	ns	(4)
	t _{OH} (PD)	Port Data Output from Rising Edge of RD during WR Cycle (Mode 0)		300	ns	(4)
ASTB, EYB	t _{PH} (ST)	Pulse Width, STROBE	180		ns	(4)
INT	t _{OH} (IT)	INT Delay Time from Rising Edge of STROBE		400	ns	
	t _{OL} (IT)	INT Delay Time from Data Match During Mode 3 Operation		420	ns	
RDY, BNDY	t _{OH} (RY)	Ready Response Time from Rising Edge of IORQ		t _{CP} ⁽¹⁾ 480	ns	(5) C _L = 80 pF
	t _{OL} (RY)	Ready Response Time from Rising Edge of STROBE		t _{CP} ⁽¹⁾ 400	ns	(5) C _L = 80 pF

A. 2.5 C_L > (t_{PH} (PH) + t_{PH} (PL) + t_{RI}) + TTL Buffer Delay, if any
 B. INT must be active for a minimum of 2 clock periods to reset the PIO.

- (1) t_{CP} = t_{PH} (PH) + t_{PH} (PL) + t_{RI} + t_{RI}
- (2) Increase t_{OD} (D) by 10 ns for each 50 pF increase in loading up to 200 pF max.
- (3) Increase t_{OL} (D) by 10 ns for each 50 pF increase in loading up to 200 pF max.
- (4) For Mode 2: t_{PH} (ST) > t_{SE} (PD)
- (5) Increase these values by 2 ns for each 10 pF increase in loading up to 100 pF max.

OUTPUT load circuit.

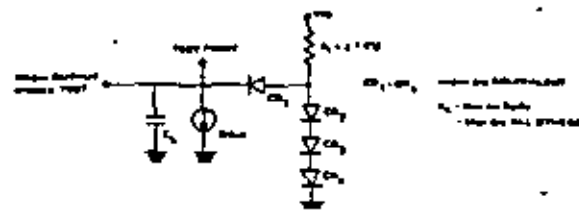

Capacitance

TA = 25° C, f = 1 MHz

Symbol	Parameter	Max.	Unit	Test Condition
C _{CP}	Clock Capacitance	10	pF	Unmeasured Pin
C _{IN}	Input Capacitance	5	pF	Returned to Ground
C _{OUT}	Output Capacitance	10	pF	Returned to Ground

Timing measurements are made at the following voltages, unless otherwise specified:

	-1'	-0'
CLOCK	4.2V	0.8V
OUTPUT	2.0V	0.8V
INPUT	2.0V	0.8V
FLOAT	ΔV	-0.5V

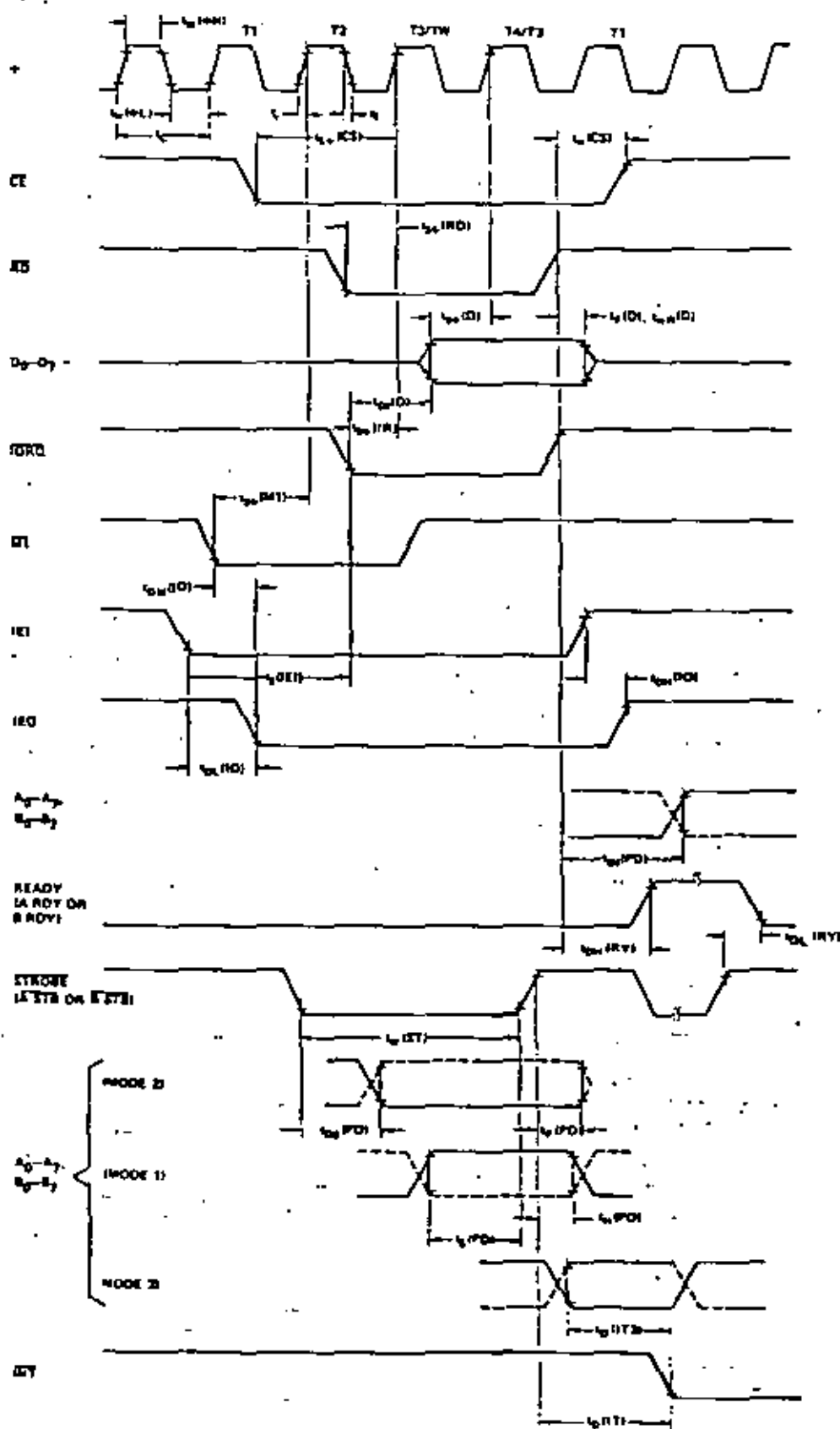

Absolute Maximum Ratings

Temperature Under Bias	Specified operating range.
Storage Temperature	-65° C to +150° C
Voltage On Any Pin With Respect To Ground	-0.5 V to +7 V
Power Dissipation	6 W

Caution

Stresses above those listed under "Absolute Maximum Rating" may cause permanent damage to the device. This is a stress rating only and functional operation of the device at these or any other condition above those indicated in the operational sections of this specification is not implied. Exposure to absolute maximum rating conditions for extended periods may affect device reliability.

Note: All AC and DC characteristics remain the same for the military grade parts except I_{OL} .

$I_L = 1.0 \text{ mA}$

Z80-PIO and Z80A-PIO D.C. Characteristics

TA = 0° C to 70° C, VCC = 5 V ± 5% unless otherwise specified

Symbol	Parameter	Min.	Max.	Unit	Test Condition
V _{ILC}	Clock Input Low Voltage	-0.5	45	V	
V _{IHC}	Clock Input High Voltage	-V _{CC} + 3	V _{CC} - 3	V	
V _{IL}	Input Low Voltage	-0.5	0.8	V	
V _{IH}	Input High Voltage	2.0	V _{CC}	V	
V _{OL}	Output Low Voltage		0.4	V	I _{OL} = 2.0 mA
V _{OH}	Output High Voltage	2.4		V	I _{OH} = 20 mA
I _{CC}	Power Supply Current		70	mA	
I _I	Input Leakage Current		10	μA	V _{IN} = 0 to V _{CC}
I _{LOH}	Tri-State Output Leakage Current in Float		10	μA	V _{OUT} = 2.4 to V _{CC}
I _{LOL}	Tri-State Output Leakage Current in Float		10	μA	V _{OUT} = 0.4 V
I _{LD}	Data Bus Leakage Current in Input Mode		±10	μA	0 < V _{IN} < V _{CC}
I _{DHD}	Darlington Drive Current	1.5		mA	V _{OH} = 1.3 V

Port B Only

Package Configuration

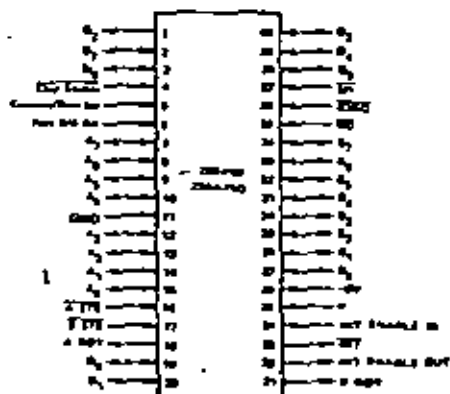

Package Outline

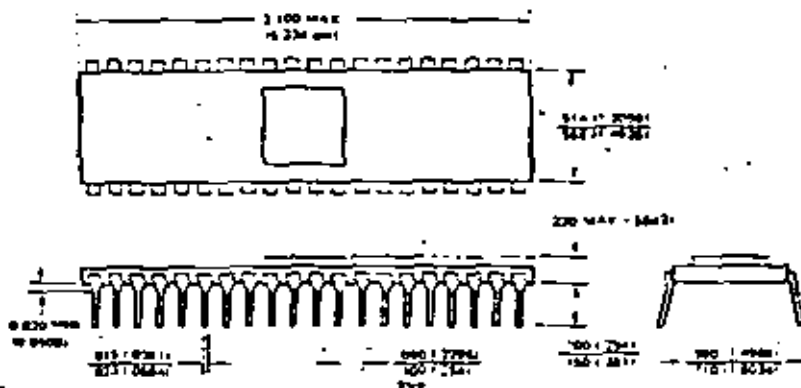

*Dimensions for metric system are in parentheses

TA = 0° C to 70° C, Vcc = +5 V ± 5%, unless otherwise noted

SIGNAL	SYMBOL	PARAMETER	MIN	MAX	UNIT	COMMENTS
φ	t _c	Clock Period	250	111	ns	
	t _{PH} (H)	Clock Pulse Width, Clock High	105	2000	ns	
	t _{PL} (L)	Clock Pulse Width, Clock Low	105	2000	ns	
	t _r	Clock Rise and Fall Times		30	ns	
	t _{su}	Any Hold Time for Specified Set-Up Time	0		ns	
CS, CE ETC.	t _{su} (CS)	Control Signal Set-Up Time to Rising Edge of φ During Read or Write Cycle	145		ns	
D _Q -D _T	t _{OH} (O)	Data Output Delay From Falling Edge of \overline{RD}		280	ns	(2)
	t _{su} (O)	Data Set-Up Time to Rising Edge of φ During Write or \overline{WT} Cycle	50		ns	
	t _{OL} (O)	Data Output Delay from Falling Edge of \overline{WR} During \overline{INTA} Cycle		250	ns	(3)
	t _{st} (O)	Delay to Floating Bus (Output Buffer Disable Time)		190	ns	
IE1	t _{su} (IE)	IE1 Set-Up Time to Falling Edge of \overline{IORQ} During \overline{INTA} Cycle	190		ns	
IE0	t _{OH} (IE)	IE0 Delay Time from Rising Edge of IE1		180	ns	(4)
	t _{OL} (IE)	IE0 Delay Time from Falling Edge of IE1		130	ns	(5)
	t _{su} (IE)	IE0 Delay Time from Falling Edge of \overline{WT} (Interrupt Occurring Just Prior to \overline{WT}) See Note A.		180	ns	(6)
\overline{IORQ}	t _{su} (IR)	\overline{IORQ} Set-Up Time to Rising Edge of φ During Read or Write Cycle	115		ns	
\overline{WT}	t _{su} (WT)	\overline{WT} Set-Up Time to Rising Edge of φ During \overline{INTA} or \overline{WT} Cycle See Note B	80		ns	
\overline{RD}	t _{su} (RD)	\overline{RD} Set-Up Time to Rising Edge of φ During Read or \overline{WT} Cycle	115		ns	
A _Q -D _T , D _Q -D _T	t _{su} (PD)	Port Data Set-Up Time to Rising Edge of STROBE (Mode 1)	230		ns	
	t _{OH} (PD)	Port Data Output Delay from Falling Edge of STROBE (Mode 2)		215	ns	(5)
	t _{st} (PD)	Delay to Floating Port Data Bus from Rising Edge of STROBE (Mode 2)		180	ns	C _L = 50 pF
	t _{su} (PD)	Port Data Stable from Rising Edge of \overline{IORQ} During \overline{WR} Cycle (Mode 0)		180	ns	(5)
ASTB, BSTB	t _p (ST)	Pulse Width, STROBE	180 (4)		ns	
\overline{INT}	t _{su} (IT)	\overline{INT} Delay Time from Rising Edge of STROBE		440	ns	
	t _{su} (IT2)	\overline{INT} Delay Time from Data Match During Mode 3 Overlap		380	ns	
RDY, RDYT	t _{su} (RY)	Ready Response Time from Rising Edge of \overline{IORQ}		t _c ⁽¹⁾	ns	(5)
	t _{su} (RY)	Ready Response Time from Rising Edge of STROBE		t _c ⁽¹⁾ 380	ns	C _L = 50 pF (5)

A. $2.5 t_c > IN-2 t_{OL} (O) + t_{OH} (O) + t_c (IE) + TTL$ Buffer Delay, if any

B. \overline{WT} must be active for a minimum of 2 clock periods to reset the PIO.

(1) $t_c = 2W (PH) + W (PL) + t_r + t_f$

(2) Increase t_{OH} (O) by 10 ns for each 50 pf increase in loading up to 200 pf max

(3) Increase t_{OL} (O) by 10 ns for each 50 pf increase in loading up to 200 pf max

(4) For Mode 2, t_p (ST) > 18 pF

(5) Increase these values by 3 ns for each 10 pf increase in loading up to 100 pf max

ZILOG SALES OFFICES

EASTERN REGION

Zilog, Inc.
30-1 Totten Pond Road
Waltham, MA 02154
TEL 617 890-0640
TWX 710 324 1974

MIDWESTERN REGION

Zilog, Inc.
1701 Woodfield Place
Suite 417
Schaumburg, IL 60195
TEL 312 885-8080
TWX 910 291 1064

WESTERN REGION

Zilog, Inc.
1815 Via el Prado
Redondo Beach, CA 90277
TEL 213 540-7749

ZILOG EUROPEAN HEADQUARTERS

Zilog (UK) Ltd.
Nicholson House
Maidenhead
Berks
England
TEL (0628) 36131/2/3
TWX 848-609

ZILOG U.S. DISTRIBUTORS

Western Region

Intermark Electronics
1802 E. Carnegie Avenue
Santa Ana, CA 92703
TEL 714 540 1322
TWX 910 395 1383

Intermark Electronics
4040 Sorrento Valley Blvd.
San Diego, CA 92121
TEL 714 279 5200
714 453 9005
TWX 910 335 1515

Intermark Electronics
1020 Stewart Drive
Sunnyvale, CA 94086
TEL 408 738 1211
TWX 910 339 9312

R.V. Weatherford Co.
8921 San Fernando Road
Glendale, CA 91201
TEL 312 849 3431
TWX 910 498 2223

R.V. Weatherford Co.
1550 Bebbutt Avenue
Abraham, CA 92205
TEL 714 834 9600
TWX 910 393 1334

V. Weatherford Co.
240 Hillview Ave.
Stanford Industrial Park
Palo Alto, CA 94304
TEL 415 493 5373

Seering Electronics
5608 6th Avenue South
Seattle, WA 98108
TEL 206 762 9100
TLX 32 9652

Seering Electronics
5608 6th Avenue South
Seattle, WA 98108
TEL 206 762 9100
TWX 32 9652

R.V. Weatherford Co.
1093 East Third Street
Pamona, CA 91766
TEL 714 623 1281
TWX 910 381 3811

R.V. Weatherford Co.
3311 W. Earl Drive
Phoenix, AZ 85017
TEL 602 272 7144
TWX 910 951 0636

Mountain

Century Electronics
121 Elizabeth, N.E.
Albuquerque, NM 87123
TEL 505 292 0823
TWX 910 889 0625

Century Electronics
2150 South 300 West
Salt Lake City, UT 84113
TEL 801 487 8531
TWX 910 923 5684

Century Electronics
8155 West 48th Avenue
Wheatridge, CO 80033
TEL 303 424 1983
TWX 910 938 0393

R.V. Weatherford Company
3905 South Mariposa
Englewood, CO 80118
TEL 303 761 3432
TWX 910 933 0173

Eastern

Hallmark Electronics
4738 Commercial Drive
Huntsville, AL 35809
TEL 205 837 8700
TWX 910 726 2187

Hallmark Electronics
1302 West McNab Road
Fort Lauderdale, FL 33309
TEL 305 971 9280
TWX 310 936 9720

Hallmark Electronics
7233 Lake Eleanor Drive
Orlando, FL 32809
TEL 305 855 4020
TWX 810 350 0183

Hallmark Electronics
3235 Amberton Drive
Baltimore, MD 21227
TEL 301 796 9300
TWX 710 862 1942

Hallmark Electronics
2208 Front Street
Building K
Raleigh, NC 27609
TEL 919 832 4445
TWX 510 928 1831

Hallmark Electronics
Pike Industrial Park
Huntington Valley, PA
TEL 215 355 7300
TWX 510 667 1730

Quay Corporation
P.O. Box 384
Freehold, NJ 07728
TEL 201 881 8700

Sierra
914 Main Street
Buffalo, NY 14202
TEL 716 884 3430

Midwestern

Hallmark Electronics
180 Grosvenor Avenue
Els Grove Village, IL 60076
TEL 312 673 6450
TWX 910 223 3645

Hallmark Electronics
11870 West 91st Street
Casperman Industrial Park
Shawnee Mission, KS 66214
TEL 913 888 4747
TWX 910 749 6620

Hallmark Electronics
9201 Penn Avenue South
Suite 10
Bloomington, MN 55431
TEL 612 844 9056
TWX 910 376 3187

Hallmark Electronics
13789 Ridder Trail
Earth City, MO 63045
TEL 314 291 5350
TWX 910 760 0671

Hallmark Electronics
6969 Washington-
Columb Road
Washington, OH 43083
TEL 614 846 1852

Hallmark Electronics
4846 S. 83rd. Road E. Avenue
Tulsa, OK 74145
TEL 918 635 8458
TWX 910 645 2290

Hallmark Electronics
3100-A Industrial Terrace
Austin, TX 78758
TEL 312 837 2841
TWX 910 874 2031

Hallmark Electronics
9331 Forest Lane
Dallas, TX 75231
TEL 214 231 5101
TWX 918 847 4721

Hallmark Electronics
8000 W. Glenn
Houston, TX 77065
TWX 910 881 2711

Hallmark Electronics
237 South Curtis
West Ada, WI 53214
TEL 414 476 1270
TWX 910 262 5186

Ordering Information

C - Ceramic

P - Plastic

S - Standard SV = 3% 0° to 70°C

E - Extended SV = 3% -40° to 85°C

M - Military SV = 10% -55° to 125°C

Example:

Z80-P10 CS (Ceramic - Standard range)

Z80-DMA Z80A-DMA

Product Specification

OCTOBER 1977

PRELIMINARY

Zilog's Z80 microcomputer product line includes a third generation LSI component set, development systems and support software. The component set includes all the logic circuits necessary for the user to build high performance microcomputer systems with virtually no external logic and a minimal number of standard low-cost memory components. The Z80-DMA (Direct Memory Access) circuit is a programmable single-channel device which provides all address, timing and control signals to effect the transfer of blocks of data between two ports within a Z80-CPU based system. These ports may be either system main memory or any system peripheral I/O device. The DMA can also search a block of data for a particular byte (bit maskable), with or without a simultaneous transfer.

Structure

- N-channel Silicon Gate Depletion Load Technology
- 40 Pin DIP
- Single 5 volt supply
- Single phase 5 volt clock
- Single channel, two port

Features

- Three classes of operation:
 - Transfer Only
 - Search Only
 - Search-Transfer
- Address and Block Length Registers fully buffered. Values for next operation may be loaded without disturbing current values.
- Dual addresses generated during a transfer (one for read port and one for write).

- Programmable data transfers and searches, automatically incrementing or decrementing the port addresses from programmed starting addresses (they can also remain fixed).
- Four modes of operation:
 - Byte-at-a-time: One byte transferred per request
 - Burst: Continues as long as ports are ready
 - Continuous: Locks out CPU until operation complete
 - Transparent: Steals refresh cycles
- Timing may be programmed to match the speed of any port.
- Interrupts on Match Found, End of Block, or Ready, may be programmed.
- An entire previous operation may be repeated automatically or on command. (Auto restart or Load)
- The DMA can signal when a specified number of bytes has been transferred, without halting transfer.
- Multiple DMA's easily configured for rotating priority.
- The channel may be enabled, disabled or reset under software control.
- Complete channel status upon program (CPU) request.
- Up to 1.25 megabyte Search or Transfer Rate.
- Daisy-chain priority interrupt and bus acknowledge included to provide automatic interrupt vectoring and bus request control, without need for additional external logic.
- TTL compatible inputs and outputs
- The CPU can read current Port counters, Byte counter, or Status Register. A mask byte can be set which defines which registers can be accessed during read operations.

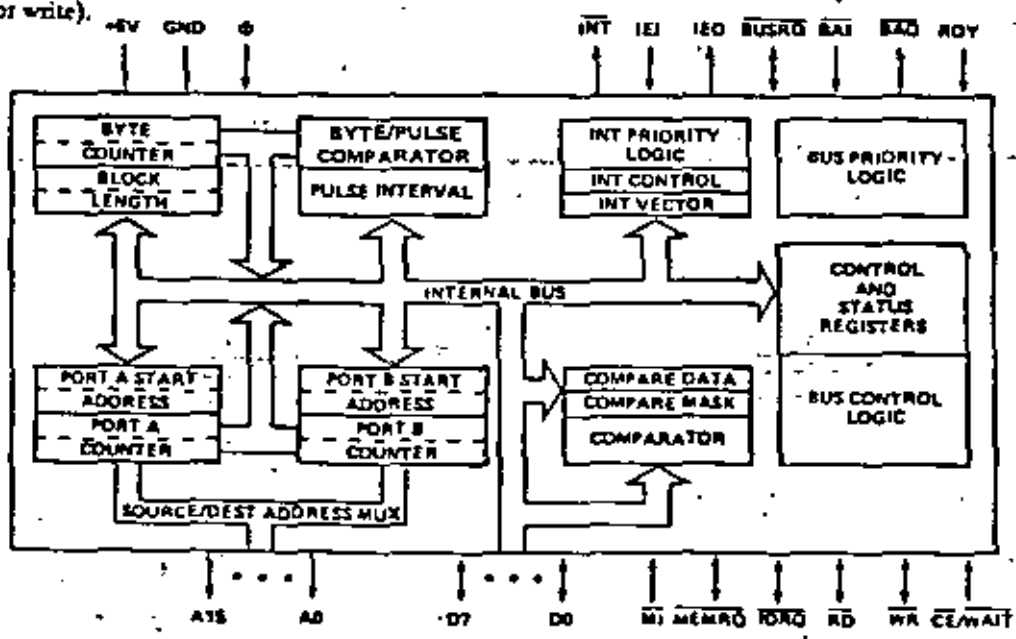

DMA Internal Block Diagram

Fig. 1

DMA Architecture

A block diagram of the Z80 DMA is shown in Figure 1. The internal structure consists of the following circuitry:

- **Bus Interface:** provides driver and receiver circuitry to interface to the Z80-CPU Bus.
- **Control Logic and Registers:** set the class, mode and other basic control parameters of the DMA.
- **Address, Byte Count and Pulse Circuitry:** generates the proper port addresses for the read and write operations, with provisions for incrementing or decrementing the address. When zero bytes remain to be handled, the byte count circuitry sets a flag in the status register. Pulse circuitry generates a pulse each time the byte counter lower 8-bits equal the pulse reg.
- **Timing Circuitry:** allows the user to completely specify the read/write timing for both of the channels' addressed ports.
- **Match Circuitry:** holds the match byte and a mask byte which allows for the comparison of only certain bits within the byte. If a match is encountered during a Search or Transfer, this circuitry sets a flag in the status register.
- **INT and BUSRQ Circuitry:** includes a control register which specifies the conditions under which the DMA can generate an interrupt; priority encoding logic to select between the generation of an INT or BUSRQ output under these conditions; and an interrupt vector register for automatic vectoring to the interrupt service routine.
- **Status Register:** holds current status of DMA.

Register Description

The following DMA-internal registers are available to the programmer:

- **Control Registers:** Hold DMA control information: such as, when to initiate an interrupt or pulse, what mode or class of operation to perform, etc. (Write Only) (8 Bits)
- **Timing Registers:** Hold read/write timing parameters for the two ports. (Write Only) (8 bits)
- **Interrupt Vector Register:** Holds the 8-bit vector that the DMA will put onto the data bus after receiving an IORQ during an interrupt acknowledge sequence if it is the highest priority device requesting an interrupt. (This register is readable only during interrupt acknowledge cycles.) (Read/Write) (8 bits)
- **Block Length Register:** Contains total block length of data to be searched and/or transferred. (Write Only) (16 bits)
- **Byte Counter:** Counts number of bytes transferred (or searched). On a Load or Continue the Byte Counter is reset to zero. Thereafter, each byte transfer operation increments it until it matches the contents of the Block Length Register, at which time End of Block is set in the status register and operation is suspended if programmed. Also if so programmed the DMA will generate an interrupt. (Read Only) (16 bits)
- **Compare Register:** Holds the byte for which a match is being sought in Search operations. (Write Only) (8 bits)
- **Mask Register:** Holds the 8 bit mask to determine which bits in the compare register are to be examined for a match. (Write Only) (8 bits)

- **Starting Address Registers (Port A and Port B):** Hold the starting addresses (upper and lower 8 bits) for the two ports involved in Transfer operations. In Search Only operations, only one port address would have to be specified. Only memory starting addresses require both upper and lower 8-bits; I/O ports are generally addressed with only the lower 8-bits, and in this case the address contained in the register is a generally fixed address. (Write Only) (16 bits each)
- **Address Counters (Port A and Port B):** These counters are loaded with the contents of the corresponding Starting Address Registers whenever Searches or Transfers are initiated with a Load or Continue. They are incremented, decremented or remain fixed, as programmed. (Read Only) (16 bits each)
- **Pulse Control Register:** Holds program-supplied length (in bytes) of block after which the DMA will provide a signal pulse on the INT pin. (Since this occurs while both BUSRQ and BUSAK are active, the CPU will not interpret this as an interrupt request. Instead, the signal is used to communicate with a peripheral I/O device.) (Write Only) (8 bits)
- **Status Register:** Match, End of Block, Ready Active, Interrupt Pending, and Write Address Valid bits indicate these functions when set. (Read Only) (8 bits)

Modes of Operation

The DMA may be programmed for one of four modes of operation. (See Command Byte 2B).

- **Byte at a time:** control is returned to the CPU after each one-byte cycle.
- **Burst:** operation continues as long as the DMA's RDY input is active, indicating that the relevant port is ready. Control returns to the CPU when RDY is inactive or at end of block or a match if so programmed.
- **Continuous:** the entire Search and/or Transfer of a block of data is completed before control is returned to CPU.
- **Transparent:** DMA operation occurs during normal memory refresh times without visible loss of CPU time.

Classes of Operation

The DMA has three classes of operation: Transfer only, Search Only and a combined Search-Transfer. (See Command Byte 1A.)

During a Transfer, data is first read from one port and then written to the other port, byte by byte. (The DMA's two ports are termed Port A and Port B.) The ports may be programmed to be either system main memory or peripheral I/O devices. Thus, a block of data might be written from a peripheral to another; or it might be written from one area in main memory to another; or from a peripheral to main memory.

During a Search, data is read only, and compared byte by byte against two DMA-internal registers, one of which contains a match byte and the other an optional mask byte which allows only certain bits to be compared. If any byte of searched data matches, a DMA-internal status bit is set; if programmed to do so, the DMA will then suspend operation and/or generate an interrupt.

The third class of operation is a combined Search-Transfer. In such an operation a block of data is transferred as described above until a match is found; then, as in a Search Only operation, the transfer may be suspended or an interrupt gener

The DMA's addressing of ports is either fixed or sequentially incrementing or decrementing from a starting address. The length of the operation (number of bytes) is specified by the programmed contents of a block length register. The DMA can address block lengths of up to 64K bytes. During a transfer two separate port addresses are generated, one during the Read cycle and one during the Write cycle.

Once the DMA has been programmed it may be "Enabled" (command byte 2d or 2a). In the enabled condition when Ready goes active the DMA will request the bus by bringing $\overline{\text{BUSRQ}}$ low. The CPU will acknowledge this with a $\overline{\text{BUSACK}}$ which will normally be attached to $\overline{\text{BAI}}$. When the DMA receives $\overline{\text{BAI}}$ it will start its programmed operation releasing $\overline{\text{BUSRQ}}$ to a "high" state when it is through.

Z80-DMA Pin Description

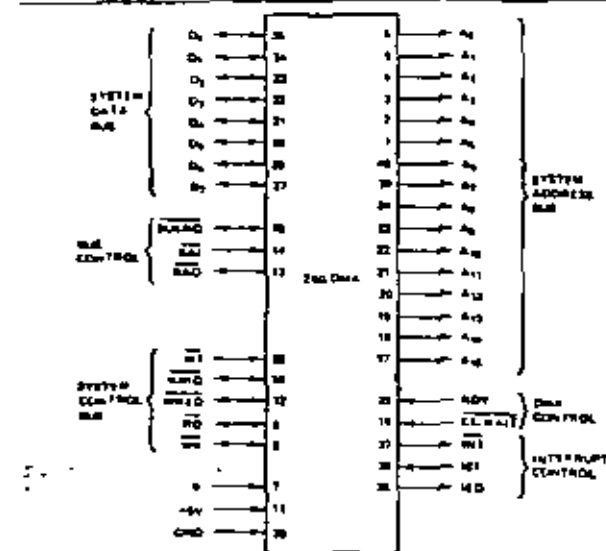

- A₀-A₁₅** System Address Bus. All sixteen of these pins are used by the DMA to address system main memory or an I/O port (output)
- D₀-D₇** System Data Bus. Commands from the CPU, DMA status and data from memory or peripherals are transferred on these tristate pins (input/output)
- +5V** Power
- GND** Ground
- Φ System clock (input)

- $\overline{\text{MI}}$ Machine cycle One signal from CPU (input)
- $\overline{\text{IORQ}}$ Input/Output Request to and from the System Bus (input/output)
- $\overline{\text{MREQ}}$ Memory REQuest to the System Bus (input/output)
- $\overline{\text{RD}}$ ReaD to and from the System Bus (input/output)
- $\overline{\text{WR}}$ WRite to and from the System Bus (input/output)
- $\overline{\text{CE/WAIT}}$ Chip Enable: may also be programmed to be **WAIT** during time when $\overline{\text{BAI}}$ is low (input)
- $\overline{\text{BUSRQ}}$ BUS ReQuest. Requests control of the CPU Address Bus, Data Bus and Status/Control Bus (input/output, open drain)
- $\overline{\text{BAI}}$ Bus Acknowledge In. Signals that the system buses have been released for DMA control (input)
- $\overline{\text{BAO}}$ Bus Acknowledge Out. $\overline{\text{BAI}}$ and $\overline{\text{BAO}}$ form a daisy-chain connection for system-wide priority bus control (output)
- $\overline{\text{INT}}$ INTerrupt request (output, open drain)
- $\overline{\text{IEI}}$ Interrupt Enable In (input)
- $\overline{\text{IEO}}$ Interrupt Enable Out. $\overline{\text{IEI}}$ and $\overline{\text{IEO}}$ form a daisy-chain connection for system-wide priority interrupt control (output)
- RDY** ReaDY is monitored by the DMA to determine when a peripheral device associated with a DMA port is ready for a read or write operation (input, programmable as active high or low)

DMA Timing Waveforms

DMA Command Write Cycle

Illustrated here is the timing associated with a command byte or control byte being written to the DMA which is to be loaded into internal registers. Z80 Output instructions satisfy this timing.

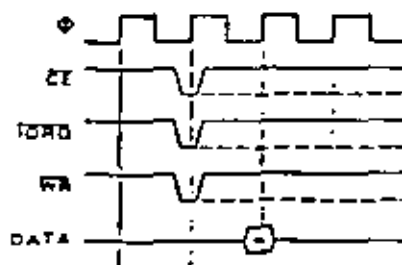

DMA Register Read Cycle

Timing is used when a read operation is performed on a DMA to access the contents of the Status Register, Address Counter or other readable registers. Z80 Input instructions satisfy this timing.



STD Memory Timing

This timing is exactly the same as used by the Z80-CPU to access system main memory, either in a Read or Write operation. The DMA will default to this timing after a power-on reset, or when a Reset or Reset Timing command is written to it; and unless otherwise programmed, will use this timing during all Transfer or Search operations involving system main memory. During the memory Read portion of a transfer cycle, data is latched in the DMA on the negative edge of Φ during T_3 and held into the following Write cycle. During the memory Write portion of a transfer cycle, data is held from the previous Read cycle and released at the end of the present cycle.

NOTE: The DMA is normally programmed for a 3 T-cycle duration in memory transactions. But **WAIT** is sampled during the negative transition of T_2 , and if it is low, T_2 will be extended another T-cycle, during which **WAIT** will again be sampled. The duration of a memory transaction cycle may thus be indefinitely extended.

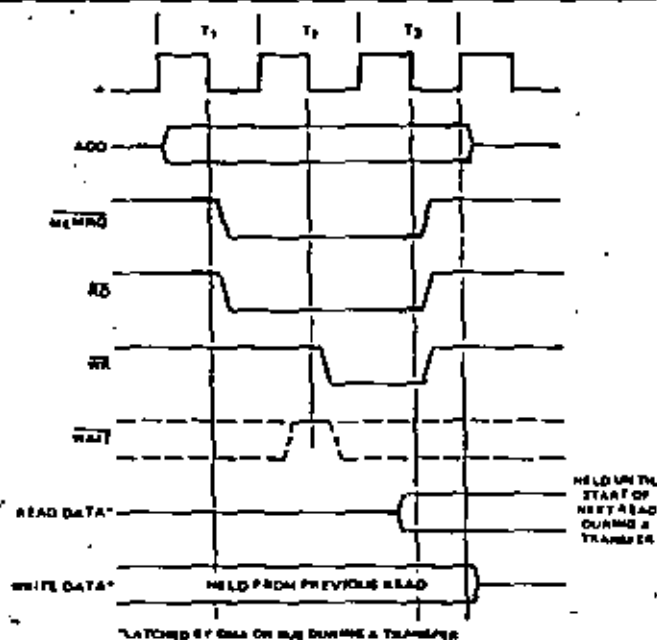

STD Peripheral Timing

This timing is identical to the Z80-CPU's Read/Write timing to I/O peripheral devices. The DMA will default to this timing after a power-on reset, or when a Reset or Reset Timing command is written to it; and unless otherwise programmed, will use this timing during all Transfer or Search operations involving I/O peripherals. During the I/O Read of a transfer cycle, data is latched on the negative edge of Φ during T_3 and is then held into the Write cycle. During an I/O Write, data is held from the previous Read cycle until the end of the Write cycle.

NOTE: If **WAIT** is low during the negative transition of T_w^* , then T_w^* will be extended another T-cycle and **WAIT** will again be sampled. The duration of a peripheral transaction cycle may thus be indefinitely extended.

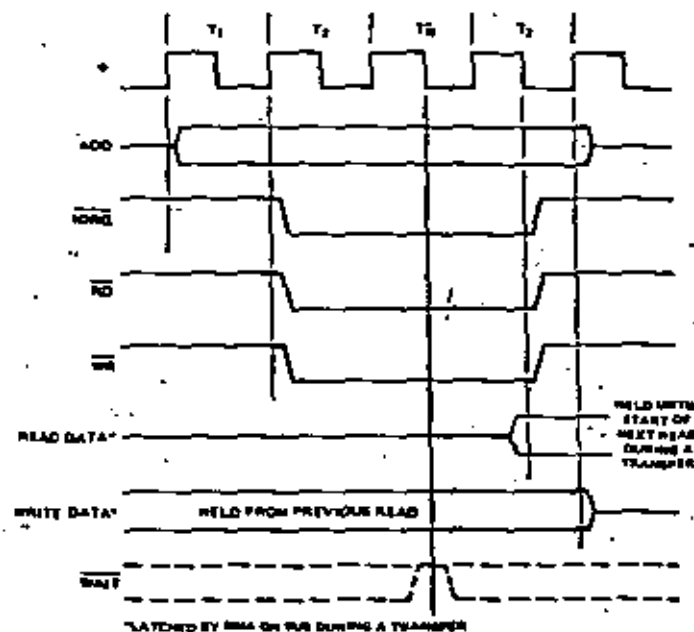

Variable Cycle

The Variable feature of the DMA allows the user to program the DMA's memory or peripheral transaction timing to values different than given above in the standard default diagrams. This permits the designer to tailor his timing to the particular requirements of his system components, and maximizes the data transfer rate while eliminating external signal conditioning logic. Cycle length can be one to four T-cycles (more if **WAIT** is used). Signal timing can be varied as shown. During a transfer, data will be latched by the DMA on the clock edge using the rising edge of **RD** and will be held on the data bus until the end of the following Write cycle.

(See Timing Control Byte, page 7.)

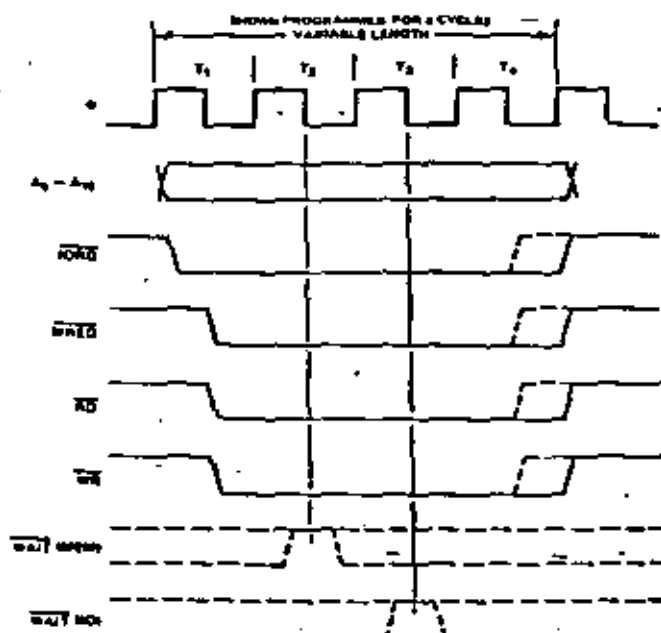

DMA Bus Request and Acceptance for Byte-at-a-Time, Burst, and Continuous Mode

Ready is sampled on every rising edge of Φ . When it is found to be active, the following rising edge of Φ generates $\overline{\text{BUSRQ}}$. After receiving $\overline{\text{BUSRQ}}$ the CPU will grant a $\overline{\text{BUSAQ}}$ which will be connected to $\overline{\text{BAI}}$ either directly or through the Bus Acknowledge Daisy Chain. When a low is detected on $\overline{\text{BAI}}$ (sampled on every rising edge of Φ), the next rising edge of Φ will start an active DMA cycle.

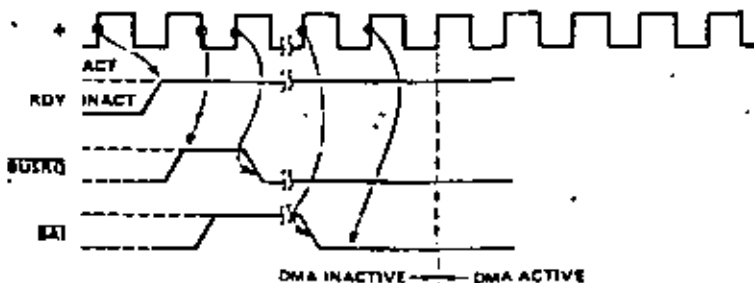

DMA Bus Release at End of Block for Burst or Continuous Mode

Timing for End of Block and DMA not programmed for Auto-restart.

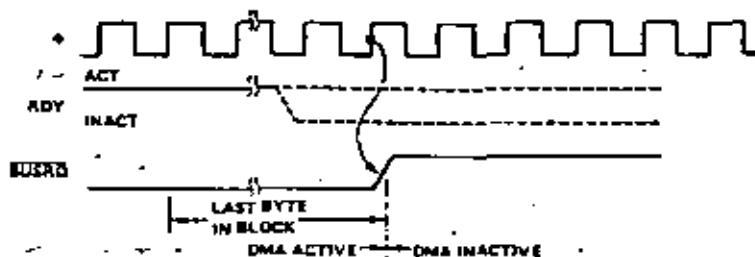

DMA Bus Release with 'Ready' for Burst and Continuous Mode

The DMA will relinquish the bus after RDY has gone inactive (Burst mode) or after an End of Block or a Match is found (Continuous mode). With RDY inactive, the DMA in Continuous mode is inactive but maintains control of the bus ($\overline{\text{BUSRQ}}$ low) until the cycle is resumed when RDY goes active.

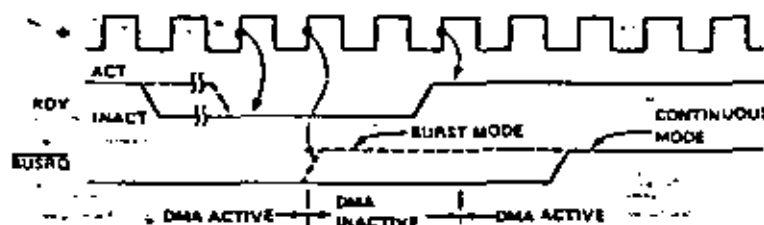

DMA Bus Release for Byte-at-a-Time Mode

In the Byte mode the DMA will release $\overline{\text{BUSRQ}}$ on the rising edge of Φ prior to the end of each Read cycle in Search Only or each Write cycle in a Transfer, regardless of the state of RDY. The next bus request will come after both $\overline{\text{BUSRQ}}$ and $\overline{\text{BAI}}$ have returned high.

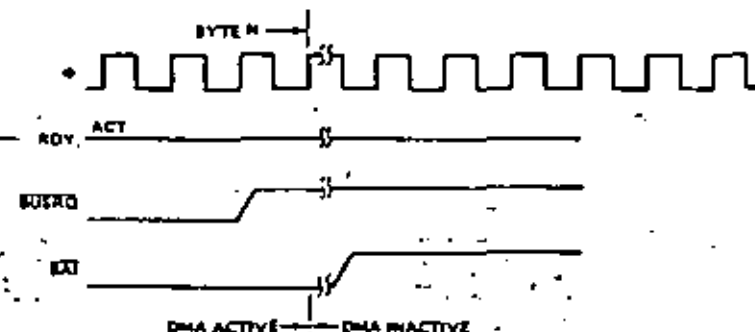

DMA Bus Release with Match for Burst or Continuous Modes

When a Match is found and the DMA is programmed to stop on Compare, the DMA performs an operation on the next byte and then releases bus.

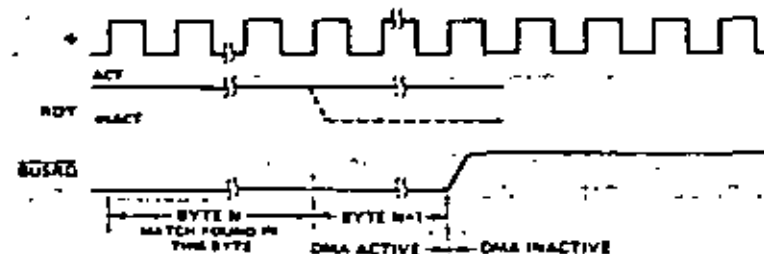

Seven registers are available on the DMA for reading. They are: 8 bits of the status register, the upper and lower 8 bits of the block length register, and two port address registers.

These are available to be read sequentially: status, BLK Lower, BLK Upper, Port A Address lower, Port A Address Upper, Port B Address lower, Port B Address upper. An internal pointer points to each register in turn as each READ is accomplished. If a register is not to be read, it may be

excluded by programming a 0 in the Read Byte. The internal pointer will skip any register not programmed with a 1 in the Read Byte. After a Reset or a Load, Reset RD must be given to set the internal pointer pointing to the first register programmed to be read by the Read Byte. After RD Status, the pointer will be pointing to the status register regardless of the Read Byte and the next read will be from the status register. The following read will be from the register pointed to before RD Status.

Programming the DMA

Previous sections of this specification have indicated the various functions and modes of the DMA. The diagrams and charts below will show how the DMA is programmed to select among these functions and modes and to adapt itself to the requirements of the user system. More detailed programming information is available in the *Z80-DMA Technical manual*.

The Z80-DMA chip may be in an "enable" state, in which it can gain control of the system buses and direct the transfer of data between its ports, or in a "disable" state, when it cannot gain control of the bus. Program commands can be written to it in either state, but writing a command to it automatically puts it in the disable state, which is maintained until an enable command is issued to the DMA. The CPU must program it in advance of any data search or transfer by addressing it as an I/O port and sending it a sequence of 8 bit command bytes via the system data bus using Output instructions. When the DMA is powered up or reset by any

means, the DMA will automatically be placed into a disable state, in which it can initiate neither bus requests nor data transfers nor interrupts.

The command bytes contain information to be loaded into the DMA's control and other registers and/or information to alter the state of the chip, such as an Enable Interrupt command. The command structure is designed so that certain bits in some commands can be set to alert the DMA to expect the next byte written to it to be for a particular internal register.

The following diagrams and charts give the function of each bit in the six different command bytes. Two of these are defined as being from Group 1, and are termed command bytes 1A and 1B. These Group 1 commands contain the most basic DMA set-up information. The other four are categorized as Group 2, and are termed commands 2A, 2B, 2C and 2D. Group 2 words specify more detailed set-up information.

Command Byte 1A



Specifies Group 1

Byte 1A cannot be 00

C ₁	C ₀	Function
0	0	Not allowed. (Command Byte 1B)
0	1	Transfer Only.
1	0	Search Only.
1	1	Search and Transfer.

D₂ = 1 Port A is read from, Port B is written to (unless the Search Only Mode has been selected, in which case Port B is never addressed).

D₂ = 0 Port B is read from, Port A is written to (unless the Search Only Mode has been selected, in which case Port A is never addressed).

Command Byte 1B



Specifies Group 1

Specifies Byte 1B

- D₄ = 1 Address for this port increments after each byte.
- D₄ = 0 Address for this port decrements after each byte.
- D₃ = 1 This port addresses an I/O peripheral.
- D₃ = 0 This port addresses main memory.
- D₂ = 1 This word programs Port A.
- D₂ = 0 This word programs Port B.

Command Byte 2A

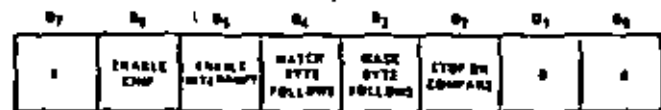

Specifies Group 2

Specifies Byte 2A

Command Byte 2B

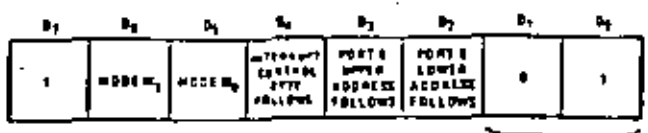

Specifies Group 2

Specifies Byte 2B

M ₁	M ₀	Mode
0	0	Byte
0	1	Continuous
1	0	Burst
1	1	Transparent

Command Byte 2C



Specifies Group 2

Specifies Byte 2C

- D₅ = 1 Automatically repeats entire operation when end of block is reached.
- D₅ = 0 No affect.
- D₄ = 1 \overline{CE} and \overline{WAIT} multiplexed on same pin.
- D₄ = 0 \overline{CE} only.
- D₃ = 1 Ready active high.
- D₃ = 0 Ready active low.

Command Byte 2D

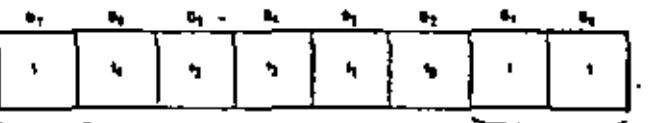

Specifies Group 2

Specifies Byte 2D

Hex	f ₄	f ₃	f ₂	f ₁	f ₀	
C3	1	0	0	0	0	Reset
C7	1	0	0	0	1	Reset Port A Timing
CB	1	0	0	1	0	Reset Port B Timing
CF	1	0	0	1	1	Load
D3	1	0	1	0	0	Continue
AB	0	1	0	1	0	Enable Int
AF	0	1	0	1	1	Disable Int
A3	0	1	0	0	0	Reset Int
87	0	0	0	0	1	Enable DMA
83	0	0	0	0	0	Disable DMA
BB	0	1	1	1	0	Read Byte Follows
A7	0	1	0	0	1	Reset RD
BF	0	1	1	1	1	RD Status
B3	0	1	1	0	0	Force Ready
B7	0	1	1	0	1	Enable After RETI
8B	0	0	0	1	0	Reset Status

Command Byte 2D Summary

- Reset Resets all interrupt circuitry, disables interrupts and bus req. logic.
- Reset Timing A or B: Resets timing for Port A or B to standard Z80-CPU timing.

- Load: Zeros Byte Counter and loads Starting Address for both Ports.
- Continue: Resets byte counter only. Addresses continue from present location.
- Enable Interrupt: Permits interrupt to occur.
- Disable Interrupt: Inhibits interrupt from occurring.
- Reset Interrupt: Resets and disables all interrupt circuits (similar to RETI).
- Enable DMA: Overall enable or disable for all operations except interrupts; does not reset any functions.
- Disable DMA: Overall enable or disable for all operations except interrupts; does not reset any functions.
- Read Byte Follows: Next write to DMA will contain a mask to program which readable registers are to be read.
- Reset RD: Next read will be from 1st register set as readable by response mask.
- RD Status: Next read will be from status register.
- Force Ready: Ready will be considered active regardless of the state of external RDY pin. Used for Mem-Mem operations where no RDY signal is needed.
- Enable after RETI: DMA will not request bus until after it has received a RETI.
- RST Status: Resets Match and End of Block status bits.

Read Byte

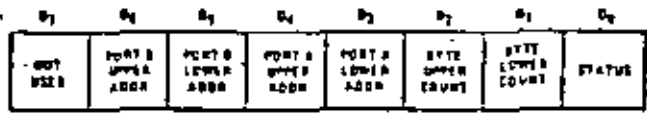

A "1" in any bit position enables that register to be read.

Interrupt Control Byte



A "1" in a bit position selects the option.

Timing Control Byte



T ₁	T ₀	Cycle Length
0	0	4
0	1	3
1	0	2
1	1	1

A "0" in D₃, D₂, D₆, or D₇ will cause the corresponding control signal to end 1/2 clock time before the end of the cycle. Note: the total operation (Read and Write in Transfer or Read in Search) must be at least 2 cycles long.

Mask Byte

A zero in a given bit position will cause a compare to be performed between that bit position in the compare word register and the same bit position in the data being read.

Match Byte

Up to an 8-bit word to be compared to D₀ - D₇ during a read. See MASK BYTE.

Status Byte (Status Bits Active-Low)

D ₇	D ₆	D ₅	D ₄	D ₃	D ₂	D ₁	D ₀
NOT USED	NOT USED	END OF BLK	MATCH	INT. PENDING	NOT USED	READY ACTIVE	WRITE ADDRESS START

Pulse Count

This 8-bit word is loaded into a register. At the completion of each operation, the register is compared with the lower 8-bits of the byte counter. When it compares, the INT line is pulsed (but no interrupt is generated).

Interrupt Vector

This 8-bit byte is supplied to the CPU during Interrupt acknowledge if the DMA is the highest priority interrupting device.

If bit 5 of the Interrupt Control Byte (see p. 7) has been set and the DMA has been programmed to interrupt on a given status condition then D₁ and D₂ of the vector will be modified as follows:

Vector Bits	D ₂	D ₁	
	0	0	INT on RDY
	0	1	Match
	1	0	End of Blk
	1	1	Match, End of Blk

DMA Programming Example

The following example will show how the DMA may be programmed to transfer data from a peripheral (Port A) to memory (Port B). The table of bytes may be stored in memory and transferred to the DMA with an output instruction such as an OTIR.

Port A	Data Flow	Port B
Peripheral Address "X"5H	Block Length 1000H Bytes	Memory Starting Address 1050H

READY from the peripheral is active high
Memory address increments on each write

		D ₇	D ₆	D ₅	D ₄	D ₃	D ₂	D ₁	D ₀	HEX
1	Command Byte 1a Sets the DMA to receive block length and Port A address and sets direction of transfer	0 Group 1	1 Blk Length Upper Follows	1 Blk Length Lower Follows	0 No Port A Upper Addr Follows	1 Port A Lower Addr Follows	1 A → B	0	1 Is Transfer No Search	6D
2	Port A Address Lower 8-bits	0	0	0	0	0	1	0	1	01
3	Block Length Lower 8-bits	0	0	0	0	0	0	0	0	00
4	Block Length Upper 8-bits	0	0	0	1	0	0	0	0	10
5	Command Byte 1b Defines Port A as peripheral with fixed address	0 Group 1	0 No Timing Follows	1 Fixed Address	X	1 Port is IO	1 This is Port "A"	0	0 1b	
6	Command Byte 1b Defines Port B as a memory with incrementing addresses	0 Group 1	0 No Timing Follows	0 Address Changes	1 Address Increments	0 Port is Memory	0 This is Port "B"	0	0 1b	14
7	Command Byte 1b Sets mode to burst, sets DMA to expect Port B starting address	1 Group 2	1 Burst Mode	0	0 No last Count Byte Follows	1 Port B Upper Addr Follows	1 Port B Lower Addr Follows	0	1 2b	CD
8	Port B Address Lower 8-bits	0	1	0	1	0	0	0	0	5D
9	Port B Address Upper 8-bits	0	0	0	1	0	0	0	0	10
10	Command Byte 2c Sets Ready Active High	1 Group 2	X	0 No Auto Restart	0 No wait States	1 Rdy Active High	X	1	0 2c	
11	Command Byte 2d loads starting addresses and resets block counter	1 Group 2	1	0	0	1	1	1	1 2A	CF
12	Command Byte 2d Enables DMA to start operation	1 Group 2	0	0	0	0	1	1	1 2d	87

To reload the same addresses and block length for a subsequent operation, only two bytes are needed.

- | | | | | | |
|--|----------|----|-----------------------------------|------------|----|
| 1. Command byte 2d
Reloads port addresses
block length | 11001111 | CF | 2. Command byte 2d
Enables DMA | 10001011 | 87 |
| | Load | | | Enable DMA | |

Absolute Maximum Ratings

Temperature Under Bias	Specified operating range.	
Average Temperature	-55°C to +150°C	
Voltage On Any Pin with Respect to Ground	-0.3V to +7V	
Power Dissipation	1.5W	

*Comment

Stresses above those listed under "Absolute Maximum Rating" may cause permanent damage to the device. This is a stress rating only and functional operation of the device at these or any other condition above those indicated in the operational sections of this specification is not implied. Exposure to absolute maximum rating conditions for extended periods may affect device reliability.

Note: All AC and DC characteristics remain the same for the military grade parts except I_{CC} .

$$I_{CC} = 200 \text{ mA.}$$

Z80-DMA D.C. Characteristics

$T_A = 0^\circ\text{C to } 70^\circ\text{C}$, $V_{CC} = 5\text{V} \pm 5\%$ unless otherwise specified

Symbol	Parameter	Min.	Typ.	Max.	Unit	Test Condition
V_{IL}	Clock Input Low Voltage	-0.3		0.43	V	
V_{IH}	Clock Input High Voltage	$V_{CC}-0.4$		$V_{CC}-0.3$	V	
V_{OL}	Output Low Voltage			0.4	V	$I_{OL} = 3 \text{ mA}$
V_{OH}	Output High Voltage	2.4			V	$I_{OH} = -250 \mu\text{A}$
I_{CC}	Power Supply Current			150	mA	$f_c = 400 \text{ kHz}$
I_{IL}	Input Leakage Current			10	μA	$V_{IN} = 0 \text{ to } V_{CC}$
I_{OL}	Tri-State Output Leakage Current in Float			50	μA	$V_{OUT} = 2.4 \text{ to } V_{CC}$
I_{OH}	Tri-State Output Leakage Current in Float			-10	μA	$V_{OUT} = 0.4\text{V}$
I_{IB}	Data Bus Leakage Current in Input Mode			± 10	μA	$0 < V_{IN} < V_{CC}$

Z80A-DMA D.C. Characteristics

$T_A = 0^\circ\text{C to } 70^\circ\text{C}$, $V_{CC} = 5\text{V} \pm 5\%$ unless otherwise specified

Symbol	Parameter	Min.	Typ.	Max.	Unit	Test Condition
V_{IL}	Clock Input Low Voltage	-0.3		0.43	V	
V_{IH}	Clock Input High Voltage	$V_{CC}-0.4$		$V_{CC}-0.3$	V	
V_{OL}	Output Low Voltage			0.4	V	$I_{OL} = 3 \text{ mA}$
V_{OH}	Output High Voltage	2.4			V	$I_{OH} = -250 \mu\text{A}$
I_{CC}	Power Supply Current		90	200	mA	$f_c = 250 \text{ kHz}$
I_{IL}	Input Leakage Current			10	μA	$V_{IN} = 0 \text{ to } V_{CC}$
I_{OL}	Tri-State Output Leakage Current in Float			10	μA	$V_{OUT} = 2.4 \text{ to } V_{CC}$
I_{OH}	Tri-State Output Leakage Current in Float			-10	μA	$V_{OUT} = 0.4\text{V}$
I_{IB}	Data Bus Leakage Current in Input Mode			± 10	μA	$0 < V_{IN} < V_{CC}$

Capacitance

$T_A = 25^\circ\text{C}$, $f = 1 \text{ MHz}$

Symbol	Parameter	Max.	Unit	Test Condition
C_ϕ	Clock Capacitance	35	pF	* Unmeasured Pins Returned to Ground
C_{IN}	Input Capacitance	5	pF	
C_{OUT}	Output Capacitance	10	pF	

Load Circuit for Output

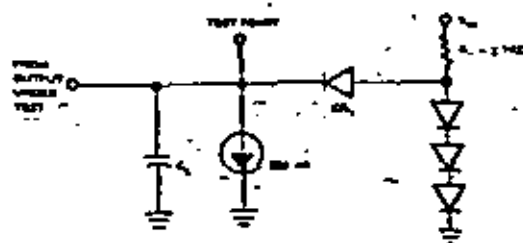

780 and 280A as a Peripheral Device (Inactive State)

Timing measurements are made at the following voltages, unless otherwise specified:

	V _I	V _O
CLOCK	4.2V	0.0V
OUTPUT	2.0V	0.0V
INPUT	2.0V	0.0V
FLOAT	3V	+0.5V

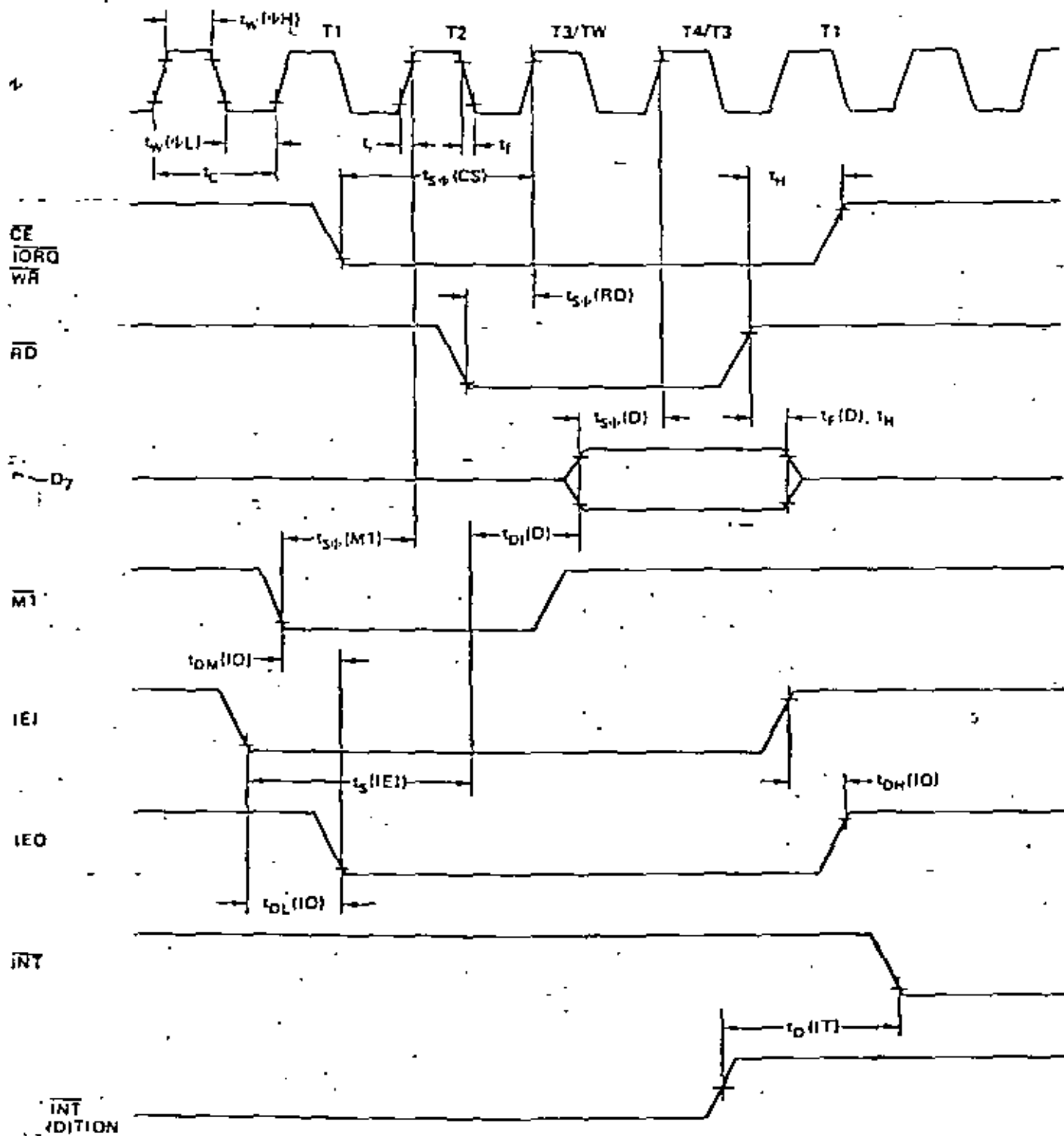

Z80-DMA as a Peripheral Device (Inactive State).

A = 0°C to 70°C, V_{CC} = ±5% ±5%, Unless Otherwise Noted

SIGNAL	SYMBOL	PARAMETER	MIN	MAX	UNIT	COMMENTS
φ	t _{CD}	Chip-Select	400	[1]	ns	
	t _{CH} (H)	Chip-Select-to-Data High	170	2000	ns	
	t _{CH} (L)	Chip-Select-to-Data Low	170	2000	ns	
	t _{CF}	Chip-Select Fall Time		20	ns	
	t _{AC}	Access Time for Selected Status Signal	0		ns	
\overline{CS} RD	t _{SR} (RD)	Control Signal Setup Time at Rising Edge of φ During \overline{CS} (RD, WR, CE)	280		ns	
D _Q -F	t _{DR} (D)	Data-Bus Delay from Falling Edge of RD		430	ns	[2]
	t _{DR} (D)	Data-Bus Time to Rising Edge of φ During Write or CE Case	50		ns	C _L = 50pF [2]
	t _{DR} (D)	Data-Bus Delay from Falling Edge of RD During RDH Case		340	ns	
	t _{DR} (D)	Internal/Output Bus (Output Buffer Disable Turnoff)		180	ns	
IE1	t _{SR} (IE1)	IE1 Setup Time to Rising Edge of RD During INTA Case	140		ns	
IE0	t _{DR} (IE0)	IE0 Setup Time from Rising Edge of IE1		210	ns	C _L = 50pF
	t _{DR} (IE0)	IE0 Setup Time from Falling Edge of IE1		180	ns	
	t _{DR} (IE0)	IE0 Setup Time from Falling Edge of MT (Interrupt Occurring Just Before MT). See Note A.		300	ns	
MT	t _{SR} (MT)	MT Setup Time to Rising Edge of φ During INTA or MT Case. See Note B.	210		ns	
RD	t _{SR} (RD)	RD Setup Time to Rising Edge of φ During RD Cycle	248		ns	
INT	t _{DR} (INT)	INT Setup Time from Controller Causing INT. INT goes inactive when DATA is inactive.		500	ns	
BA0	t _{DR} (BA0)	BA0 Setup Time from Rising Edge of BA1	180	200	ns	
	t _{DR} (BA0)	BA0 Setup Time from Falling Edge of BA1	150	200	ns	

[1] t_{CD} = t_{CH}(H) + t_{CH}(L) + t_{CF}[2] Increase t_{DR}(D) by 10 ns for each 50pF increase in loading up to 200pF max.[3] Increase t_{DR}(D) by 10 ns for each 50pF increase in loading up to 200pF max.A. t_{DR}(IE0) > t_{DR}(IE0) + t_{DR}(IE1) + TTL Buffer Delay, if any

Z80A-DMA as a Peripheral Device (Inactive State).

A = 0°C to 70°C, V_{CC} = +5V ± 5%, Unless Otherwise Noted

SIGNAL	SYMBOL	PARAMETER	MIN	MAX	UNIT	COMMENTS
φ	t _{CPH(1)}	Clock Period	250	(1)	ns	
	t _{CPHL(1)}	Clock Pulse Width, Clock High	105	2000	ns	
	t _{CPHL(2)}	Clock Pulse Width, Clock Low	105	2000	ns	
	t _{CF}	Clock Rise and Fall Times		20	ns	
t _{set}	t _{set} (CS)	Any Hold Time for Setup and Setup Times	0		ns	
CE	t _{CE(CE)}	Control Signal Setup Time to Rising Edge of φ During Write Cycle	145		ns	
DQ ₁₇	t _{DR(1)}	Data Output Delay from Falling Edge of \overline{RD}		380	ns	(2)
	t _{DR(2)}	Data Setup Time to Rising Edge of φ During Write or $\overline{M1}$ Cycle	50		ns	(3)
	t _{DR(3)}	Data Output Delay from Falling Edge of \overline{RD} During $\overline{M1}$ Cycle		350	ns	C _L = 50pF
OE	t _{OE(1)}	Data Output Delay from Falling Edge of \overline{OE} During $\overline{M1}$ Cycle		110	ns	(2)
	t _{OE(2)}	OE Setup Time to Falling Edge of \overline{RD} During $\overline{M1}$ Cycle	140		ns	
IE0	t _{DM(1)}	IE0 Delay Time from Rising Edge of IE1		180	ns	C _L = 50pF
	t _{DL(1)}	IE0 Delay Time from Falling Edge of IE1		130	ns	
	t _{DM(2)}	IE0 Delay from Falling Edge of $\overline{M1}$ if Interrupt Occurring Just Prior to $\overline{M1}$. See Note A.		180	ns	
$\overline{M1}$	t _{set(M1)}	$\overline{M1}$ Setup Time to Rising Edge of φ During $\overline{M1}$ or $\overline{M2}$ Cycle. See Note B.	80		ns	
\overline{RD}	t _{set(RD)}	\overline{RD} Setup Time to Rising Edge of φ During $\overline{M1}$ Cycle	115		ns	
INT	t _{DI(1)}	INT Delay Time from Assertion Causing \overline{INT} . \overline{INT} generated only when DMA is inactive.		500	ns	
BA0	t _{DM(BA0)}	BA0 Delay from Rising Edge of BA1	150	200	ns	
	t _{DL(BA0)}	BA0 Delay from Falling Edge of BA1	150	200	ns	

(1) ϕ = $\overline{M1}$ or $\overline{M2}$ or $\overline{M3}$ or $\overline{M4}$ (2) Increase t_{DR(1)} by 10 ns for each 50pF increase in loading up to 200pF max.(3) Increase t_{DR(2)} by 10 ns for each 50pF increase in loading up to 200pF max.A. $2.5 t_{DI(1)} > t_{DM(1)} + t_{DM(2)} + t_{DL(1)} + t_{DL(2)} + t_{DM(3)} + t_{DL(3)} + t_{DM(4)} + t_{DL(4)}$ = TTL Buffer Delay, if any

Z80-DMA as a Bus Controller (Active State)

A = 0°C to 70°C, V_{CC} = +5V ± 5%, Unless Otherwise Noted.

SIGNAL	SYMBOL	PARAMETER	MIN	MAX	UNIT	COMMENTS
φ	t _{CPH}	Clock Period	4	(1)	μs	
	t _{CPHL}	Clock Pulse Width, Clock High	180	2000	ns	
	t _{CPHL}	Clock Pulse Width, Clock Low	180	2000	ns	
	t _{CP}	Clock Rise and Fall Time		30	ns	
A0-15	t _{OAD}	Address Output Delay		145	ns	
	t _{FIAD}	Output to Float		110	ns	C _L = 50pF
	t _{AS}	Address Stable Prior to \overline{MREQ} (Memory Cycle)	(1)		ns	D
	t _{AS}	Address Stable Prior to \overline{IORQ} , \overline{RD} or \overline{WR} (I/O Cycle)	(2)		ns	D
	t _{AS}	Address Stable from \overline{RD} or \overline{WR}	(3)		ns	D
D0-7	t _{OD}	Data Output Delay		280	ns	
	t _{FD}	Delay to Float During Write Cycle		80	ns	
	t _{DD} (D)	Set-up Time to Rising Edge of Clock During Read When Rising Edge Leads \overline{RD}	80		ns	C _L = 200pF
	t _{DD} (D)	Data Setup Time to Falling Edge of Clock During Read When Falling Edge Leads \overline{RD}	80		ns	
	t _{DS}	Data Stable Prior to \overline{WR} (Memory Cycle)	(4)		ns	D
MREQ	t _{DMR}	MREQ Delay from Falling Edge of Clock, \overline{MREQ} Low		100	ns	
	t _{DMR}	MREQ Delay from Rising Edge of Clock, \overline{MREQ} High		100	ns	
	t _{DMR}	MREQ Delay from Falling Edge of Clock, \overline{MREQ} High		100	ns	
	t _{DMR}	MREQ Delay from Falling Edge of Clock, \overline{MREQ} Low	(5)		ns	C _L = 50pF
IORQ	t _{DIR}	\overline{IORQ} Delay from Rising Edge of Clock, \overline{IORQ} Low		80	ns	
	t _{DIR}	\overline{IORQ} Delay from Falling Edge of Clock, \overline{IORQ} Low		130	ns	
	t _{DIR}	\overline{IORQ} Delay from Rising Edge of Clock, \overline{IORQ} High		100	ns	
	t _{DIR}	\overline{IORQ} Delay from Falling Edge of Clock, \overline{IORQ} High		130	ns	
RD	t _{DR}	\overline{RD} Delay from Rising Edge of Clock, \overline{RD} Low		100	ns	
	t _{DR}	\overline{RD} Delay from Falling Edge of Clock, \overline{RD} Low		130	ns	
	t _{DR}	\overline{RD} Delay from Rising Edge of Clock, \overline{RD} High		100	ns	
	t _{DR}	\overline{RD} Delay from Falling Edge of Clock, \overline{RD} High		110	ns	
WR	t _{DWR}	\overline{WR} Delay from Rising Edge of Clock, \overline{WR} Low		80	ns	
	t _{DWR}	\overline{WR} Delay from Falling Edge of Clock, \overline{WR} Low		80	ns	
	t _{DWR}	\overline{WR} Delay from Falling Edge of Clock, \overline{WR} High		100	ns	
	t _{DWR}	\overline{WR} Delay from Rising Edge of Clock, \overline{WR} High	(10)		ns	C _L = 50pF
WAIT	t _W	WAIT Setup Time to Falling Edge of Clock	70		ns	
BUSRD	t _B	BUSRD Delay Time from Rising Edge of Clock	100		ns	
\overline{IRD}		Delay to Float (\overline{MREQ} , \overline{IORQ} , \overline{RD} and \overline{WR})		100	ns	

(1) t_{CPH} = t_{CPHL} = t_{CP} = 4 μs

(1) t_{AS} = t_{AS} = t_{AS} = 70 ns
 (2) t_{AS} = t_{AS} = 80 ns
 (3) t_{AS} = t_{AS} = 40 ns
 (4) t_{DS} = t_{DS} = 80 ns

(4) t_{DS} = t_{DS} = 180 ns
 (5) t_{DMR} = t_{DMR} = 180 ns
 (7) t_{DR} = t_{DR} = 80 ns

(5) t_{DMR} = t_{DMR} = 40 ns
 (6) t_{DMR} = t_{DMR} = 40 ns CPU Timing
 t_{DMR} = t_{DMR} = 30 ns Variable 1 Cycle

(10) t_{DWR} = t_{DWR} = 40 ns CPU Timing
 t_{DWR} = t_{DWR} = 30 ns Variable 1 Cycle

- NOTES
- Cross should be observed until the DMA data bus when \overline{RD} is active.
 - All output signals are normally tri-state'd, so they may be totally asymmetric with respect to the load.
 - Output Delay vs. Loading Characteristics
 TA = 10°C, V_{CC} = +5V ± 5%
 (1) C_L = +100pF (A₀-A₁₅ and Control Signals), and 30 pF max. to timing points.
 - During Standby CPU Timing

Z80A-DMA as a Bus Controller (Active State)
 A = 0°C to 70°C, Vcc = +5V±5%, Unless Otherwise Noted.

SIGNAL	SYMBOL	PARAMETER	MIN	MAX	UNIT	COMMENTS
φ	t _{PH}	Clock Period	25	[12]	μsec	
	t _{PLH(φ)}	Clock Pulse Width, Clock High	110	2000	μsec	
	t _{PLL(φ)}	Clock Pulse Width, Clock Low	110	2000	μsec	
	t _{RI}	Clock Rise and Fall Time		30	μsec	
	t _{OFF}	Clock to Output Delay		110	μsec	
A0-15	t _{OH(A)}	Address Output Delay		90	μsec	C _L = 50pF
	t _{PL(A)}	Delay to Float			μsec	0
	t _{AS}	Address Setup Prior to \overline{MEMO} (Memory Cycle)	[1]		μsec	0
	t _{AD}	Address Setup Prior to \overline{IORQ} , \overline{RD} or \overline{WR} (I/O Cycle)	[2]		μsec	0
	t _{AW}	Address Setup from \overline{RD} or \overline{WR}	[3]		μsec	0
D0-7	t _{OH(D)}	Data Output Delay		130	μsec	
	t _{FD}	Delay to Float During Write Cycle			μsec	
	t _{SD(D)}	Data Setup Time to Rising Edge of Clock During Read When Rising Edge Ends \overline{RD}	25		μsec	C _L = 200pF
	t _{SD(D)}	Data Setup Time to Falling Edge of Clock During Read When Falling Edge Ends \overline{RD}	30		μsec	
	t _{SW}	Data Setup Prior to \overline{WR} (Memory Cycle)	[7]		μsec	0
D0-7	t _{WD}	Data Setup Prior to \overline{WR} (I/O Cycle)	[8]		μsec	0
	t _{WD}	Data Setup from \overline{WR}	[9]		μsec	0
	t _{WH}	Any Hold Time for Setup Time		0	μsec	
\overline{MEMO}	t _{OL(φ)(\overline{MEMO})}}	\overline{MEMO} Delay from Falling Edge of Clock, \overline{MEMO} Low		75	μsec	
	t _{OH(φ)(\overline{MEMO})}}	\overline{MEMO} Delay from Rising Edge of Clock, \overline{MEMO} High		75	μsec	
	t _{OL(φ)(\overline{MEMO})}}	\overline{MEMO} Delay from Falling Edge of Clock, \overline{MEMO} High	[10]		μsec	C _L = 50pF
	t _{PL(φ)(\overline{MEMO})}}	Pulse Width, \overline{MEMO} Low	[11]		μsec	0
	t _{PH(φ)(\overline{MEMO})}}	Pulse Width, \overline{MEMO} High	[11]		μsec	0
\overline{IORQ}	t _{OL(φ)(\overline{IORQ})}}	\overline{IORQ} Delay from Rising Edge of Clock, \overline{IORQ} Low		75	μsec	
	t _{OH(φ)(\overline{IORQ})}}	\overline{IORQ} Delay from Rising Edge of Clock, \overline{IORQ} High		80	μsec	
	t _{PL(φ)(\overline{IORQ})}}	\overline{IORQ} Delay from Falling Edge of Clock, \overline{IORQ} High		80	μsec	C _L = 50pF
\overline{RD}	t _{OL(φ)(\overline{RD})}}	\overline{RD} Delay from Rising Edge of Clock, \overline{RD} Low		75	μsec	
	t _{OH(φ)(\overline{RD})}}	\overline{RD} Delay from Falling Edge of Clock, \overline{RD} Low		95	μsec	
	t _{OL(φ)(\overline{RD})}}	\overline{RD} Delay from Rising Edge of Clock, \overline{RD} High		75	μsec	C _L = 50pF
	t _{OH(φ)(\overline{RD})}}	\overline{RD} Delay from Falling Edge of Clock, \overline{RD} High		80	μsec	
\overline{WR}	t _{OL(φ)(\overline{WR})}}	\overline{WR} Delay from Rising Edge of Clock, \overline{WR} Low		80	μsec	
	t _{OH(φ)(\overline{WR})}}	\overline{WR} Delay from Falling Edge of Clock, \overline{WR} Low		80	μsec	
	t _{OL(φ)(\overline{WR})}}	\overline{WR} Delay from Rising Edge of Clock, \overline{WR} High		80	μsec	C _L = 50pF
	t _{OH(φ)(\overline{WR})}}	\overline{WR} Delay from Falling Edge of Clock, \overline{WR} High		80	μsec	
	t _{PL(φ)(\overline{WR})}}	Pulse Width, \overline{WR} Low	[10]		μsec	
\overline{WAIT}	t _{SW(WT)}	\overline{WAIT} Setup Time to Falling Edge of Clock	75		μsec	
\overline{BURQ}	t _{SD(BQ)}	\overline{BURQ} Delay Time from Rising Edge of Clock	100		μsec	
\overline{MEMO}	t _{PH(MO)}	Delay to Float (\overline{MEMO} , \overline{IORQ} , \overline{RD} and \overline{WR})		80	μsec	

[12] t_{PH} = t_{PH(φ)} + t_{OFF} + t_{PL(φ)}

[1] t_{AS} = t_{AS(φ)} + t_{OH(A)} + t_{OFF}
 [2] t_{AD} = t_{AD(φ)}
 [3] t_{AW} = t_{AW(φ)} + t_{OH(A)}
 [4] t_{AW} = t_{AW(φ)} + t_{OFF}

[5] t_{SW} = t_{SW(φ)} + t_{OH(D)}
 [6] t_{WD} = t_{WD(φ)} + t_{OH(D)}
 [7] t_{WD} = t_{WD(φ)} + t_{OFF}

[8] t_{OL(φ)(\overline{MEMO})}} = t_{OL(φ)} + t_{OH(φ)}
 [9] t_{PL(φ)(\overline{MEMO})}} = t_{PL(φ)} + t_{OH(φ)} + 40 Set CPU Timing
 t_{PH(φ)(\overline{MEMO})}} = t_{PH(φ)} + t_{OH(φ)} + 30 Variable I Cycle

[10] t_{PL(φ)(\overline{MEMO})}} = t_{PL(φ)} + 40 Set CPU Timing
 t_{PH(φ)(\overline{MEMO})}} = t_{PH(φ)} + 30 Variable I Cycle

- NOTES:
- Delay obtained for switching 500Ω the DMA data bus when \overline{RD} is active.
 - All control signals are internally synchronized, so they may be treated synchronously with respect to the clock.
 - Output Delay vs. Loading Capacitance
 TA = 10°C, Vcc = +5V±5%
 [1] C_L = 100pF (Signal Control Signals), and 20 nsec. on timing diagrams.
 During Suspended CPU Timing

Z80 and Z80A as a Bus Controller (Active State)

Timing measurements are made at the following voltages, unless otherwise specified:

	"1"	"0"
CLOCK	4.2V	0.8V
OUTPUT	2.0V	0.8V
INPUT	2.0V	0.8V
FLOAT	ΔV	+0.5V

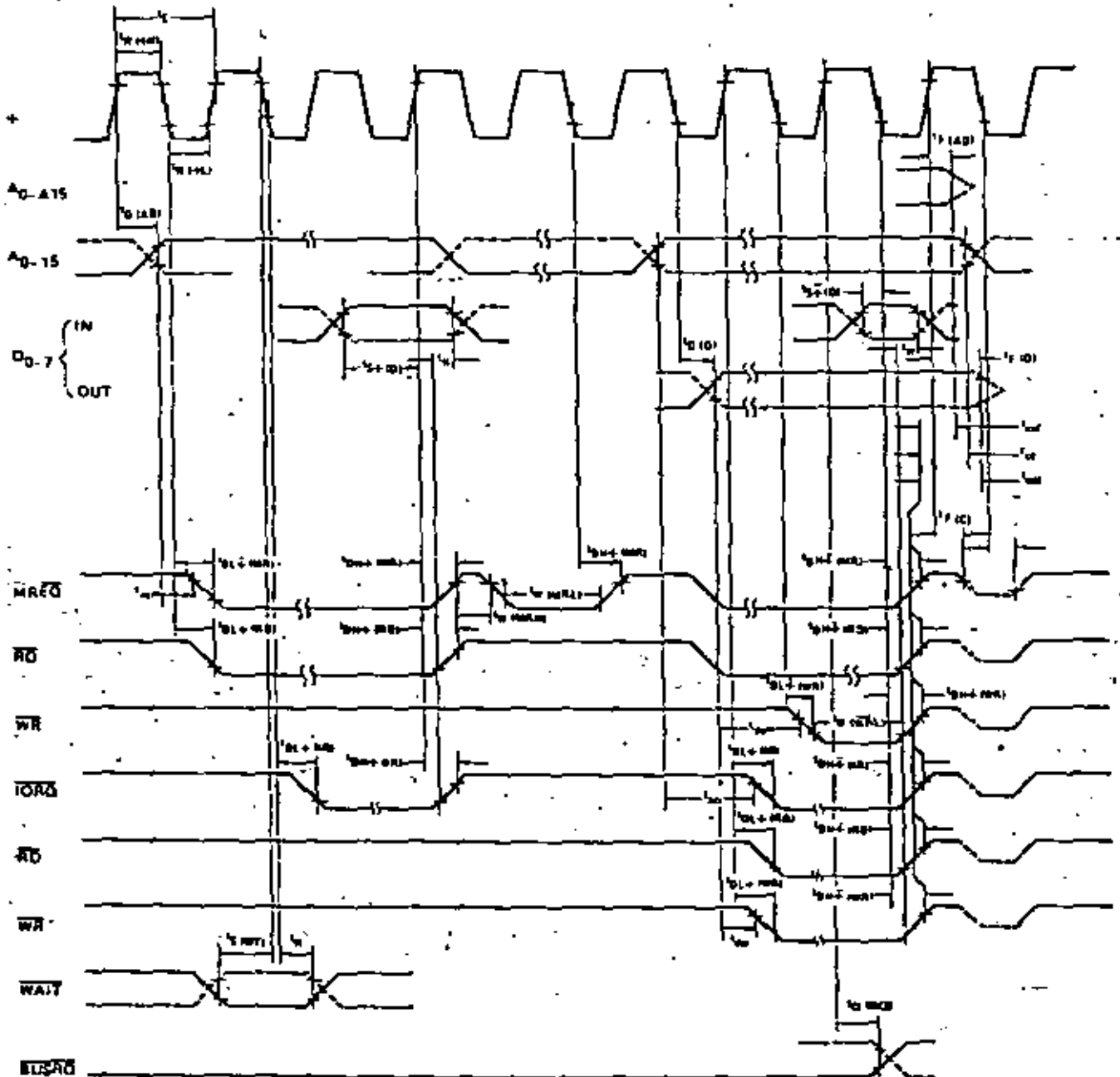

Package Configuration

Package Outline

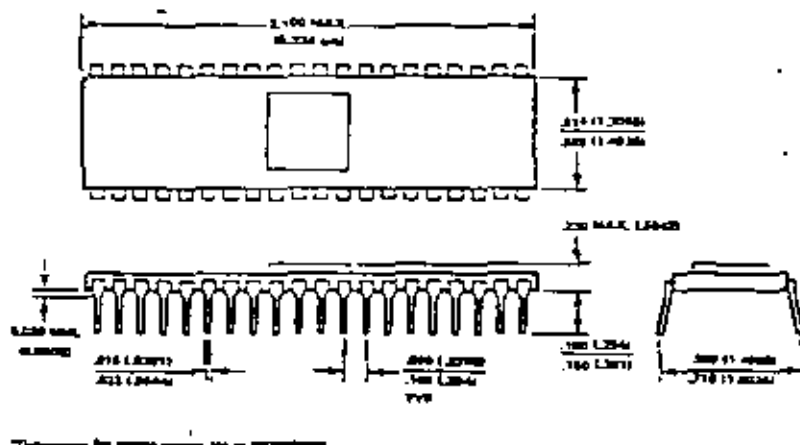
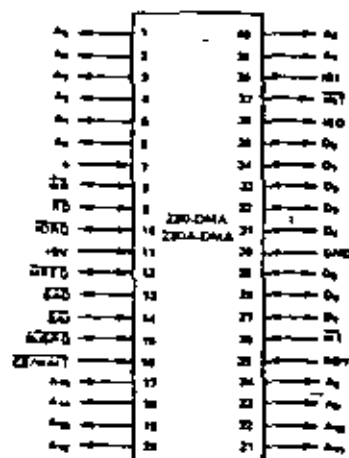

EASTERN

Hallmark Electronics
4719 Commercial Drive
Huntsville, AL 35805
TEL 305 817 8700
TWX 810 728 2187

Hallmark Electronics
1302 West McNabb Road
Fort Lauderdale, FL 33309
TEL 305 971 9280
TWX 510 936 9720

Mark Electronics
3 Lake Eberhart Drive
Orlando, FL 32809
TEL 305 851 3020
TWX 410 850 0183

Hallmark Electronics
3335 Amberley Drive
Baltimore MD 21227
TEL 301 796 9300
TWX 710 642 1942

Hallmark Electronics
1208 Front Street
Building K
Raleigh, NC 27609
TEL 919 832 4465
TWX 510 928 1833

Hallmark Electronics
Pike Industrial Park
Huntington Valley, PA
TEL 215 355 7300
TWX 510 647 1750

Summit
916 Main Street
Buffalo, NY 14202
TEL 716 884 3450

Wilshire Electronics
2354 State Street
Hartford, CT 06117
TEL 203 281 1146
TWX 800 922 1734

Wilshire Electronics
1255 New Highway
Farmingdale, LI, NY 11735
TEL 516 293 5775
TWX 212 895 8707

Wilshire Electronics
One Wilshire Road
Burlington, MA 01803
TEL 617 272 8200
TWX 710 332 6359

Wilshire Electronics
2111 Paulson Avenue
Clifton, NJ 07015
TEL 201 340 1900
TWX 710 989 7052

MIDWESTERN

Hallmark Electronics
180 Grossman Avenue
E33 Gross Village, IL 60076
TEL 312 437 8800
TWX 910 223 3645

Hallmark Electronics
11870 West 91st Street
Completion Industrial Park
Shawnee Mission, KS 66214
TEL 913 888 4747
TWX 910 749 6420

Hallmark Electronics
9201 Penn Avenue South
Suite 10
Bloomington, MN 55435
TEL 612 894 9056
TWX 910 576 3187

Hallmark Electronics
13789 Rider Trail
Earth City, MO 63045
TEL 314 291 3350
TWX 910 740 0671

Hallmark Electronics
6969 Worthington Galena Road
Worthington, OH 43085
TEL 614 846 1082

Hallmark Electronics
4846 S. 83rd E. Avenue
Tulsa, OK 74145
TEL 918 835 8458
TWX 910 845 2290

Hallmark Electronics
3100-A Industrial Terrace
Austin, TX 78758
TEL 512 837 3841
TWX 910 874 2031

Hallmark Electronics
9333 Forest Lane
Dallas, TX 75222
TEL 314 234-7400
TWX 910 847 4723

Hallmark Electronics
8000 W. Glina
Houston, TX 77063
TEL 713 781 6100
TWX 910 841 2713

Hallmark Electronics
237 South Curtis
West Allis, WI 53214
TEL 414 476 1270
TWX 910 242 3186

RM Electronics
4840 South Downes
Keokuk, IA 52008
TEL 616 521 9300
TWX 810 273 8779

MOUNTAIN

Century Electronics
121 Elizabeth, NE
Albuquerque, NM 87123
TEL 505 292 2700
TWX 910 989 0623

Century Electronics
2150 South 300 West
Salt Lake City, UT 84113
TEL 801 467 8551
TWX 910 925 5686

Century Electronics
8155 West 48th Avenue
Wheatridge, CO 80037
TEL 303 424 1985
TWX 910 938 0393

R. V. Weatherford Co.
3905 South Mariposa
Englewood, CO 80110
TEL 303 761 5432
TWX 910 933 0173

WESTERN

Intermark Electronics
1802 E. Carnegie Avenue
Santa Ana, CA 92705
TEL 714 340 1322
TWX 910 595 1583

Intermark Electronics
4040 Sorrento Valley Blvd.
San Diego, CA 92131
TEL 714 279 5700
714 453 9003
TWX 910 335 1515

Intermark Electronics
1020 Stewart Drive
Saneyria, CA 94086
TEL 408 738 1111
TWX 910 339 9312

R. V. Weatherford Co.
6921 San Fernando Road
Clendale, CA 91201
TEL 713 849 3431
TWX 910 498 2223

R. V. Weatherford Co.
1350 Rabbit Avenue
Anaheim, CA 92805
TEL 714 634 9600
TWX 910 593 1334

R. V. Weatherford Co.
1095 East Third Street
Pomona, CA 91765
TEL 714 623 1261
TWX 910 581 3212

R. V. Weatherford Co.
2240 Highway Avenue
Stanford Industrial Park
Palo Alto, CA 94304
TEL 415 493 5373

R. V. Weatherford Co.
3311 W. Earl Drive
Phoenix, AZ 85017
TEL 602 272 7144
TWX 910 951 0636

Swearing Electronics
5608 6th Avenue South
Seattle, WA 98108
TEL 206 762 9100
TLX 32-9652

CANADA

Falmer Electronics
3647 Ferry Street
Montreal, Quebec,
CANADA H4P 2E3

Ordering Information

- C - Ceramic
- P - Plastic
- S - Standard 5V ±5%, 0° to 70°C
- E - Extended 5V ± 5% -40° to 85°C
- M - Military 5V ±10% -55° to 125°C

Example:

Z80-DMA CS (Ceramic-Standard range)

Z80[®]-CTC Z80A[®]-CTC

Product Specification

APRIL 1978

27

The Zilog Z80 product line is a complete set of micro-computer components, development systems and support software. The Z80 microcomputer component set includes all of the circuits necessary to build high-performance microcomputer systems with virtually no other logic and a minimum number of low cost standard memory elements.

The Z80-Counter Timer Circuit (CTC) is a programmable, four channel device that provides counting and timing functions for the Z80-CPU. The Z80-CPU configures the Z80-CTC's four independent channels to operate under various modes and conditions as required.

Structure

- N-Channel Silicon Gate Depletion Load Technology
- 28 Pin DIP
- Single 5 volt supply
- Single phase 5 volt clock
- Four independent programmable 8-bit counter/16-bit timer channels

Features

- Each channel may be selected to operate in either a counter mode or timer mode.
- Programmable interrupts on counter or timer states.

- A time constant register automatically reloads the down counter at zero and the cycle is repeated.
- Readable down counter indicates number of counts-to-go until zero.
- Selectable 16 or 256 clock prescaler for each timer channel.
- Selectable positive or negative trigger may initiate timer operation.
- Three channels have zero count/timeout outputs capable of driving Darlington transistors.
- Daisy chain priority interrupt logic included to provide for automatic interrupt vectoring without external logic.
- All inputs and outputs fully TTL compatible.
- Outputs directly compatible with Z80-SIO.

CTC Architecture

A block diagram of the Z80-CTC is shown in figure 1. The internal structure of the Z80-CTC consists of a Z80-CPU bus interface, internal control logic, four counter channels, and interrupt control logic. Each channel has an interrupt vector for automatic interrupt vectoring, and interrupt priority is determined by channel number with channel 0 having the highest priority.

The channel logic is composed of 2 registers, 2 counters and control logic as shown in figure 2. The registers include an 8-bit time constant register and an 8-bit channel control register. The counters include an 8-bit readable down counter and an 8-bit prescaler. The prescaler may be programmed to divide the system clock by either 16 or 256.

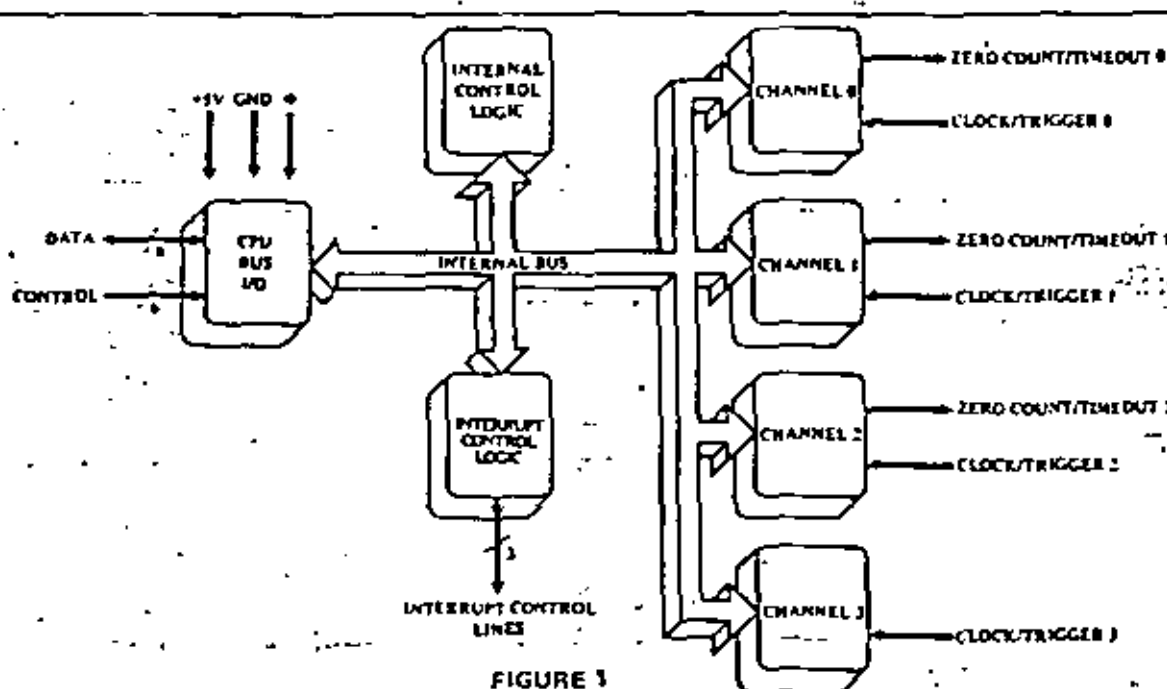

FIGURE 1
CTC BLOCK DIAGRAM

1. **Constant Register** - 8 bits, loaded by the CPU to initialize and re-load Down Counter at a count of zero.

Channel Control Register - 8 bits, loaded by the CPU to select the mode and conditions of channel operation.

Down Counter - 8 bits, loaded by the Time Constant Register under program control and automatically at a

count of zero. At any time, the CPU can read the number of counts-to-go until a zero count. This counter is decremented by the prescaler in timer mode and CLK/TRIG in counter mode.

Prescaler - 8 bit counter, divides system clock by 16 or 256 for decrementing Down Counter. It is used in timer mode only.

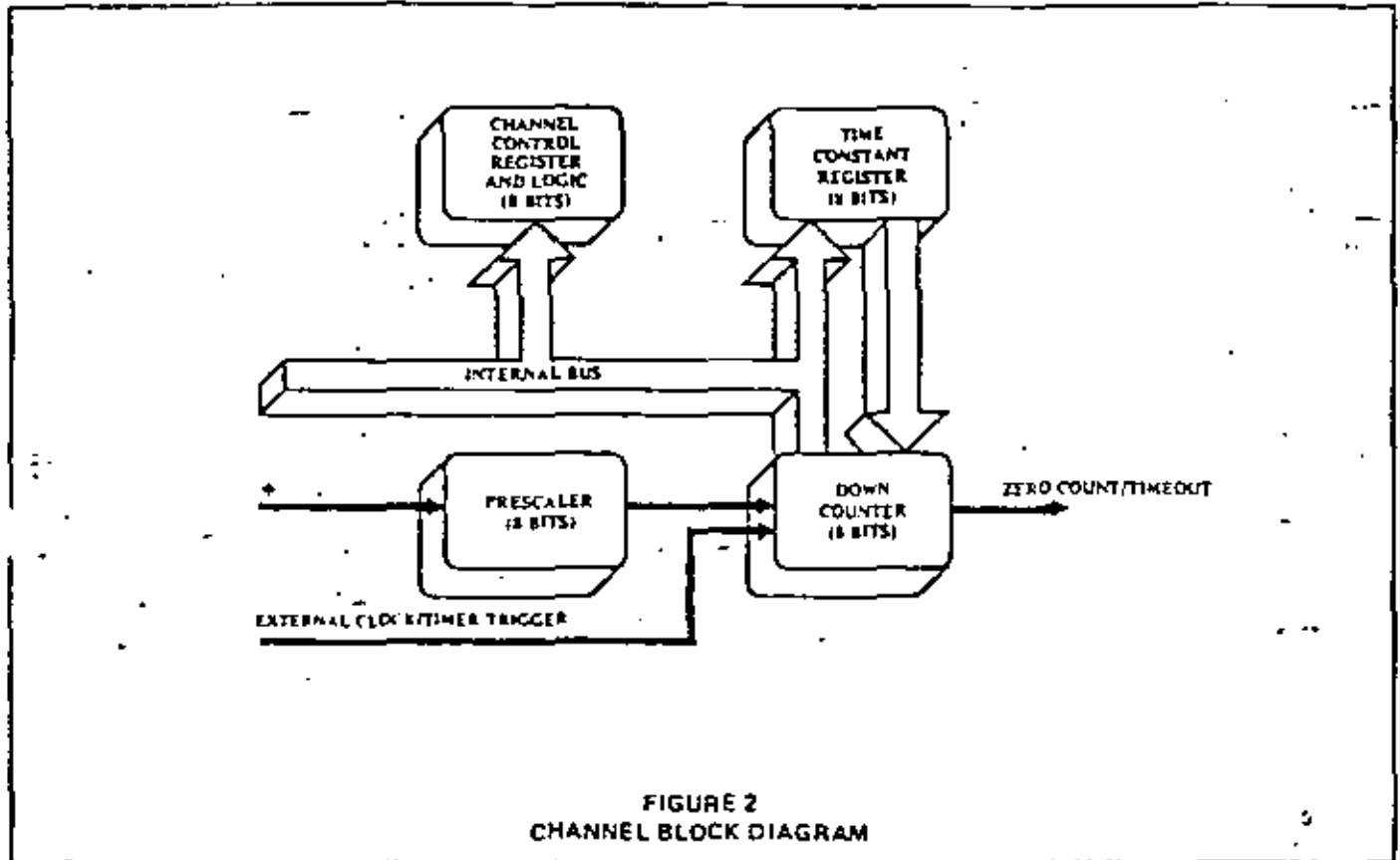
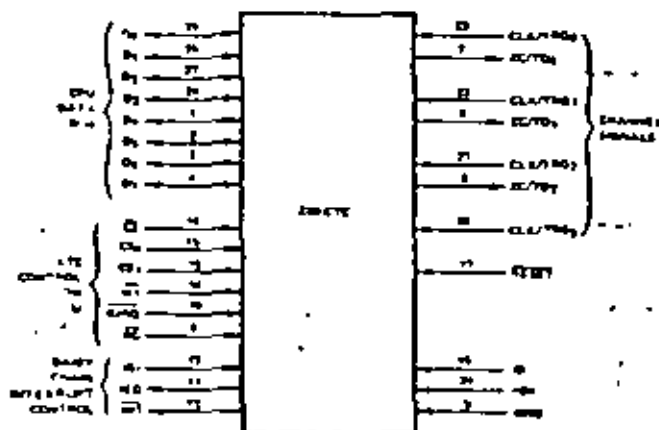

FIGURE 2
CHANNEL BLOCK DIAGRAM

Z80-CTC Pin Description



- CLK/TRIG₀ Channel 0 External Clock or Timer Trigger (Input)
- CLK/TRIG₁ Channel 1 External Clock or Timer Trigger (Input)
- CLK/TRIG₂ Channel 2 External Clock or Timer Trigger (Input)
- CLK/TRIG₃ Channel 3 External Clock or Timer Trigger (Input)
- ZC/T0₀ Channel 0 Zero Count or Timeout (output, active high)

ZC/TO_1	Channel 1 Zero Count or Timeout (output, active high)	\overline{RD}	Read Cycle Status from the Z80-CPU (input, active low)
ZC/TO_2	Channel 2 Zero Count or Timeout (output, active high)	IEI	Interrupt Enable In (input, active high)
$CS_1 - CS_0$	Channel Select (input, active high). These form a 2-bit binary address of the channel to be accessed.	IEO	Interrupt Enable Out (output, active high). IEI and IEO form a daisy chain connection for priority interrupt control
$D_7 - D_0$	Z80-CPU Data Bus (bidirectional, tristate)	\overline{INT}	Interrupt Request (output, open drain, active low)
\overline{CE}	Chip Enable (input, active low)	RESET	RESET stops all channels from counting and resets channel interrupt enable bits in all control registers. During reset time $ZC/TO_{1,2}$ and \overline{INT} go to the inactive states. IEO reflects the state of IEI, and the data bus output drivers go to the high impedance state (input, active low)
ϕ	System Clock (input)		
$\overline{M1}$	Machine Cycle One Signal from Z80-CPU (input, active low)		
\overline{IORQ}	Input/Output Request from Z80-CPU (input, active low)		

Timing Waveforms

CTC WRITE CYCLE

Illustrated here is the timing for loading a channel control word, time constant and interrupt vector. No wait states are allowed for writing to the CTC other than the automatically inserted (T_w^*). Since the CTC does not receive a specific write signal, it internally generates its own from the lack of an \overline{RD} signal.

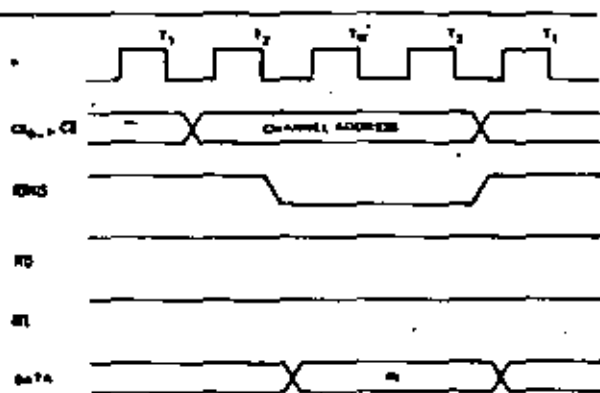

CTC READ CYCLE

Illustrated here is the timing for reading a channel's Down Counter when in Counter Mode. The value read onto the data bus reflects the number of external clock's rising edges prior to the rising edge of cycle (T_2). No wait states are allowed for reading the CTC other than the automatically inserted (T_w^*).

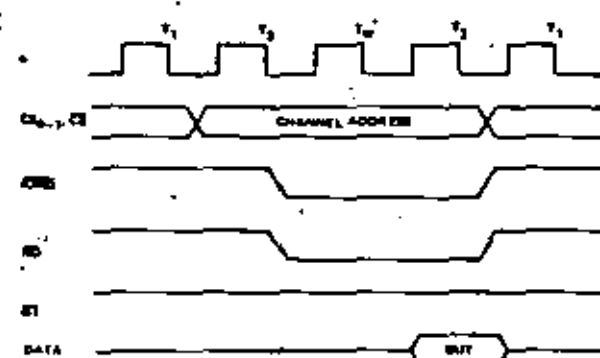

INTERRUPT ACKNOWLEDGE CYCLE

Some time after an interrupt is requested by the CTC, the CPU will send out an interrupt acknowledge ($\overline{M1}$ and \overline{IORQ}). During this time the interrupt logic of the CTC will determine the highest priority channel which is requesting an interrupt. To insure that the daisy chain enable lines stabilize, channels are inhibited from changing their interrupt request status when $\overline{M1}$ is active. If the CTC Interrupt Enable Input (IEI) is active, then the highest priority interrupting channel places the contents of its interrupt vector register onto the Data Bus when \overline{IORQ} goes active. Additional wait cycles are allowed.

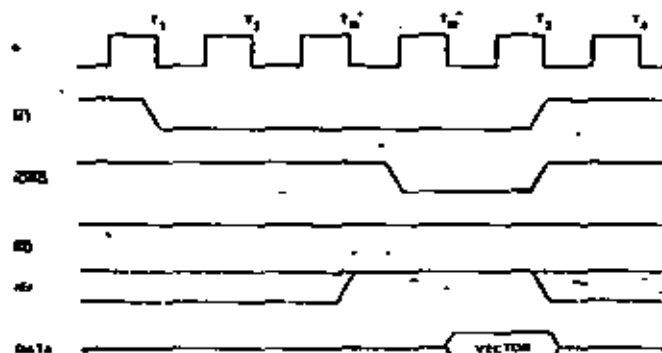

RETURN FROM INTERRUPT CYCLE

If a Z80 peripheral device has no interrupt pending and is not under service, then its IEO = IEI. If it has an interrupt under service (i.e. it has already interrupted and received an interrupt acknowledge) then its IEO is always low, inhibiting lower priority chips from interrupting. If it has an interrupt pending which has not yet been acknowledged, IEO will be low unless an "ED" is decoded as the first byte of a two byte opcode. In this case, IEO will go high until the next opcode byte is decoded, whereupon it will again go low. If the second byte of the opcode was a "4D" then the opcode was an RETI instruction.

After an "ED" opcode is decoded, only the peripheral device which has interrupted and is currently under service will have its IEI high and its IEO low. This device is the highest priority device in the daisy chain which has received an interrupt acknowledge. All other peripherals have IEI = IEO. If the next opcode byte decoded is "4D", this peripheral device will reset its "interrupt under service" condition.

Wait cycles are allowed in the $\overline{M1}$ cycles.

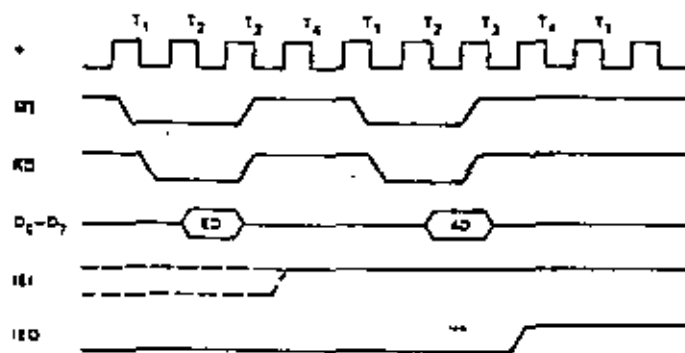

DAISY CHAIN INTERRUPT SERVICING

Illustrated at right is a typical nested interrupt sequence which may occur in the CTC. In this sequence channel 2 interrupts and is granted service. While this channel is being serviced, higher priority channel 1 interrupts and is granted service. The service routine for the higher priority channel is completed and a RETI instruction is executed to indicate to the channel that its routine is complete. At this time the service routine of lower priority channel 2 is completed.

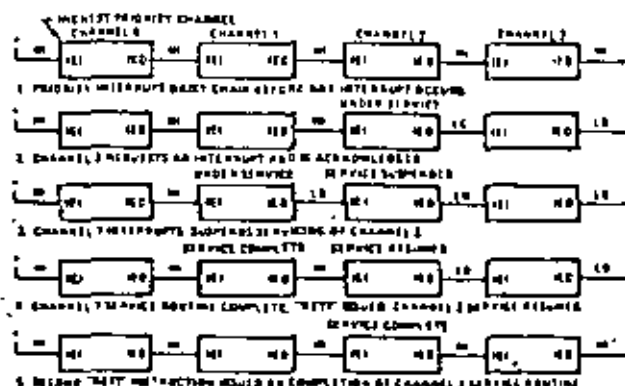

CTC COUNTING AND TIMING

In the counter mode the rising or falling edge of the CLK input causes the counter to be decremented. The edge is detected totally asynchronously and must have a minimum CLK pulse width. However, the counter is synchronous with Φ therefore a setup time must be met when it is desired to have the counter decremented by the next rising edge of Φ .

In the timer mode the prescaler may be enabled by a rising or falling edge on the TRG input. As in the counter mode, the edge is detected totally asynchronously and must have a minimum TRG pulse width. However, when timing is to start with respect to the next rising edge of Φ a setup time must be met. The prescaler counts rising edges of Φ .

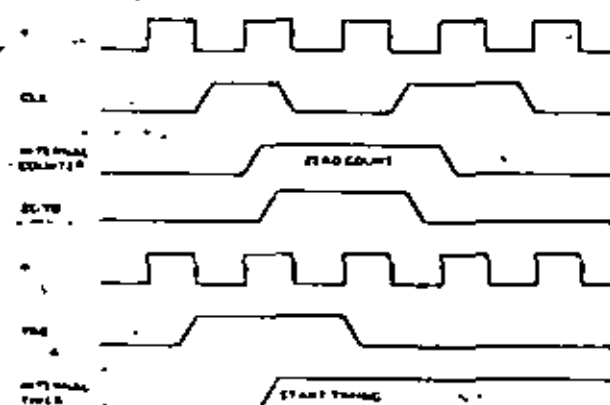



SELECTING AN OPERATING MODE

When selecting a channel's operating mode, bit 0 is set to 1 to indicate this word is to be stored in the channel control register.

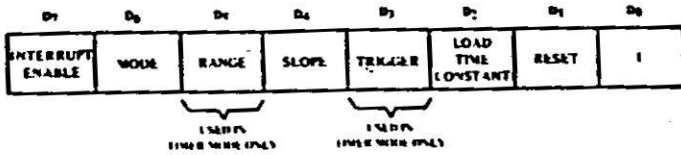

- Bit 7 = 0 Channel interrupts disabled.
- Bit 7 = 1 Channel interrupts enabled to occur every time Down Counter reaches a count of zero. Setting Bit 7 does not let a preceding count of zero cause an interrupt.
- Bit 6 = 0 Timer Mode – Down counter is clocked by the prescaler. The period of the counter is:
 $t_c = P \cdot TC$
 t_c = system clock period
 P = prescale of 16 or 256
 TC = 8 bit binary programmable time constant (256 max)
- Bit 6 = 1 Counter Mode – Down Counter is clocked by external clock. The prescaler is not used.
- Bit 5 = 0 Timer Mode Only–System clock Φ is divided by 16 in prescaler.
- Bit 5 = 1 Timer Mode Only–System clock Φ is divided by 256 in prescaler.
- Bit 4 = 0 Timer Mode – negative edge trigger starts timer operation.
Counter Mode – negative edge decrements the down counter.
- Bit 4 = 1 Timer Mode – positive edge trigger starts timer operation.
Counter Mode – positive edge decrements the down counter.
- Bit 3 = 0 Timer Mode Only – Timer begins operation on the rising edge of T_2 of the machine cycle following the one that loads the time constant.
- Bit 3 = 1 Timer Mode Only – External trigger is valid for starting timer operation after rising edge of T_2 of the machine cycle following the one that loads the time constant. The Prescaler is decremented 2 clock cycles later if the setup time is met, otherwise 3 clock cycles.

- Bit 2 = 0 No time constant will follow the channel control word. One time constant must be written to the channel to initiate operation.
- Bit 2 = 1 The time constant for the Down Counter will be the next word written to the selected channel. If a time constant is loaded while a channel is counting, the present count will be completed before the new time constant is loaded into the Down Counter.
- Bit 1 = 0 Channel continues counting.
- Bit 1 = 1 Stop operation. If Bit 2 = 1 channel will resume operation after loading a time constant, otherwise a new control word must be loaded.

LOADING A TIME CONSTANT

An 8-bit time constant is loaded into the Time Constant register following a channel control word with bit 2 set. All zeros indicate a time constant of 256.

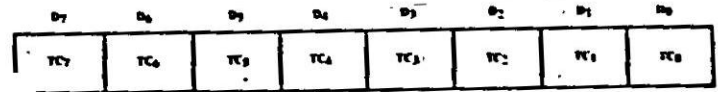

LOADING AN INTERRUPT VECTOR

The Z80-CPU requires that an 8-bit interrupt vector be supplied by the interrupting channel. The CPU forms the address for the interrupt service routine of the channel using this vector. During an interrupt acknowledge cycle the vector is placed on the Z80 Data Bus by the highest priority channel requesting service at that time. The desired interrupt vector is loaded into the CTC by writing into channel 0 with a zero in D0. D7-D3 contain the stored interrupt vector; D2 and D1 are not used in loading the vector. When the CTC responds to an interrupt acknowledge, these two bits contain the binary code of the highest priority channel which requested the interrupt and D0 contains a zero since the address of the interrupt service routine starts at an even byte. Channel 0 is the highest priority channel.

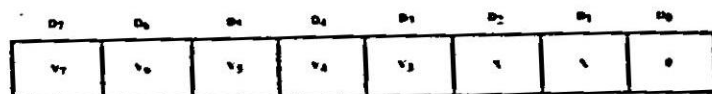

TA = 0°C to 70°C, VCC = +5 V ± 5%, unless otherwise noted

Signal	Symbol	Parameter	Min	Max	Unit	Comments
Φ	t _C	Clock Period	400	[1]	ns	
	t _W (ΦH)	Clock Pulse Width, Clock High	170	2000	ns	
	t _W (ΦL)	Clock Pulse Width, Clock Low	170	2000	ns	
	t _r , t _f	Clock Rise and Fall Times	-	30	ns	
-	t _H	Any Hold Time for Specified Setup Time	0		ns	
CS, CE, etc.	t _{SE} (CS)	Control Signal Setup Time to Rising Edge of Φ During Read or Write Cycle	160		ns	
D ₀ -D ₇	t _{DR} (D)	Data Output Delay from Rising Edge of \overline{RD} During Read Cycle		480	ns	[2]
	t _S (D)	Data Setup Time to Rising Edge of Φ During Write or M1 Cycle	60		ns	
	t _{DI} (D)	Data Output Delay from Falling Edge of \overline{IORQ} During INTA Cycle		340	ns	[2]
	t _F (D)	Delay to Floating Bus (Output Buffer Disable Time)		230	ns	
IEI	t _S (IEI)	IEI Setup Time to Falling Edge of \overline{IORQ} During INTA Cycle	200		ns	
IEO	t _{DH} (IO)	IEO Delay Time from Rising Edge of IEI		220	ns	[3]
	t _{DL} (IO)	IEO Delay Time from Falling Edge of IEI		190	ns	[3]
	t _{DM} (IO)	IEO Delay from Falling Edge of $\overline{M1}$ (Interrupt Occurring just Prior to M1)		300	ns	[3]
\overline{IORQ}	t _S (IR)	\overline{IORQ} Setup Time to Rising Edge of Φ During Read or Write Cycle	250		ns	
$\overline{M1}$	t _S (M1)	$\overline{M1}$ Setup Time to Rising Edge of Φ During INTA or M1 Cycle	210		ns	
\overline{RD}	t _S (RD)	\overline{RD} Setup Time to Rising Edge of Φ During Read or M1 Cycle	240		ns	
INT	t _{OCK} (IT)	INT Delay Time from Rising Edge of CLK/TRG		2t _C (Φ) + 200		Counter Mode
	t _{OΦ} (IT)	INT Delay Time from Rising Edge of Φ		t _C (Φ) + 200		Timer Mode
CLK/TRG ₀₋₃	t _C (CK)	Clock Period	2t _C (Φ)			Counter Mode
	t _r , t _f	Clock and Trigger Rise and Fall Times		50		
	t _S (CK)	Clock Setup Time to Rising Edge of Φ for Immediate Count	210			Counter Mode
	t _S (TR)	Trigger Setup Time to Rising Edge of Φ for Enabling of Prescaler on Following Rising Edge of Φ	210			Timer Mode
	t _W (CH)	Clock and Trigger High Pulse Width	200			Counter and Timer Modes
	t _W (CL)	Clock and Trigger Low Pulse Width	200			Counter and Timer Modes
ZC/TQ ₀₋₂	t _{DH} (ZC)	ZC/TQ Delay Time from Rising Edge of Φ, ZC/TQ High		190		Counter and Timer Modes
	t _{DL} (ZC)	ZC/TQ Delay Time from Falling Edge of Φ, ZC/TQ Low		190		Counter and Timer Modes

Notes: [1] t_C = t_W(ΦH) + t_W(ΦL) + t_r + t_f.

[2] Increase delay by 10 nsec for each 50 pF increase in loading, 200 pF maximum for data lines and 100 pF for control lines.

[3] Increase delay by 2 nsec for each 10 pF increase in loading, 100 pF maximum.

[4] RESET must be active for a minimum of 3 clock cycles.

OUTPUT LOAD CIRCUIT

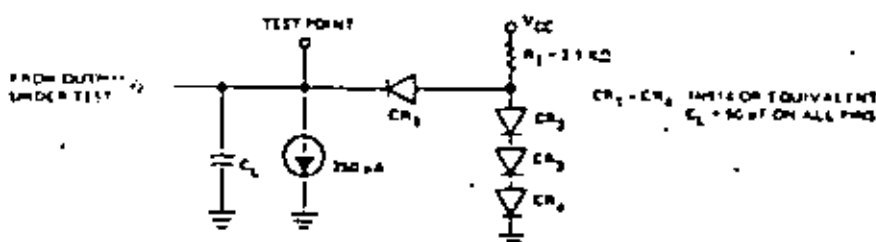

$T_A = 0^\circ\text{C}$ to 70°C , $V_{CC} = +5\text{V} \pm 5\%$, unless otherwise noted

Signal	Symbol	Parameter	Min	Max	Unit	Comments
ϕ	t_C	Clock Period	250	[1]	ns	
	$t_{WH}(\Phi_H)$	Clock Pulse Width, Clock High	105	2000	ns	
	$t_{WL}(\Phi_L)$	Clock Pulse Width, Clock Low	105	2000	ns	
	t_r, t_f	Clock Rise and Fall Times		30	ns	
	t_H	Any Hold Time for Specified Setup Time	0		ns	
CS, CE, etc	$t_{SE}(CS)^L$	Control Signal Setup Time to Rising Edge of ϕ During Read or Write Cycle	60		ns	
D_0-D_7	$t_{DR}(D)$	Data Output Delay from Falling Edge of \overline{RD} During Read Cycle		380	ns	[2]
	$t_{SE}(D)$	Data Setup Time to Rising Edge of ϕ During Write or M1 Cycle	50		ns	
	$t_{DI}(D)$	Data Output Delay from Falling Edge of \overline{IORQ} During INTA Cycle		160	ns	[2]
	$t_f(D)$	Delay to Floating Bus (Output Buffer Disable Time)		110	ns	
IE1	$t_S(IE1)$	IE1 Setup Time to Falling Edge of \overline{IORQ} During INTA Cycle	140		ns	
IE0	$t_{DH}(IE0)$	IE0 Delay Time from Rising Edge of IE1		160	ns	[3]
	$t_{DL}(IE0)$	IE0 Delay Time from Falling Edge of IE1		130	ns	[3]
	$t_{DM}(IE0)$	IE0 Delay from Falling Edge of $\overline{M1}$ (Interrupt Occurring just Prior to $\overline{M1}$)		190	ns	[3]
\overline{IORQ}	$t_{SE}(\overline{IORQ})$	\overline{IORQ} Setup Time to Rising Edge of ϕ During Read or Write Cycle	115		ns	
$\overline{M1}$	$t_{SE}(\overline{M1})$	$\overline{M1}$ Setup Time to Rising Edge of ϕ During INTA or M1 Cycle	90		ns	
\overline{RD}	$t_{SE}(\overline{RD})$	\overline{RD} Setup Time to Rising Edge of ϕ During Read or M1 Cycle	115		ns	
INT	$t_{DCK}(INT)$	INT Delay Time from Rising Edge of CLK/TRG		$2t_C(\Phi) + 140$		Counter Timer Mode
	$t_{D\Phi}(INT)$	INT Delay Time from Rising Edge of ϕ		$t_C(\Phi) + 140$		
CLK/TRG ₀₋₃	$t_C(CLK)$	Clock Period	$2t_C(\Phi)$			Counter J
	t_r, t_f	Clock and Trigger Rise and Fall Times		50		
	$t_S(CLK)$	Clock Setup Time to Rising Edge of ϕ for Immediate Count	210			Counter Mode Timer Mode
	$t_S(TR)$	Trigger Setup Time to Rising Edge of ϕ for enabling of Prescaler on Following Rising Edge of ϕ	210			
	$t_{WH}(CTH)$	Clock and Trigger High Pulse Width	200			Counter and Timer M1
	$t_{WL}(CTL)$	Clock and Trigger Low Pulse Width	200			Counter and Timer Modes
ZC/\overline{TD}_{0-2}	$t_{DH}(ZC)$	ZC/ \overline{TD} Delay Time from Rising Edge of ϕ, ZC/ \overline{TD} High		190		Counter Timer Modes
	$t_{DL}(ZC)$	ZC/ \overline{TD} Delay Time from Falling Edge of ϕ, ZC/ \overline{TD} Low		180		Counter Timer Modes Counter Timer Mo

Notes: [1] $t_C = t_{WH}(\Phi_H) + t_{WL}(\Phi_L) + t_r + t_f$

[2] Increase delay by 10 nsec for each 50 pF increase in loading, 200 pF maximum for data lines and 100 pF for control lines.

[3] Increase delay by 2 nsec for each 10 pF increase in loading, 100 pF maximum.

[4] RESET must be active for a minimum of 3 clock cycles.

OUTPUT LOAD CIRCUIT

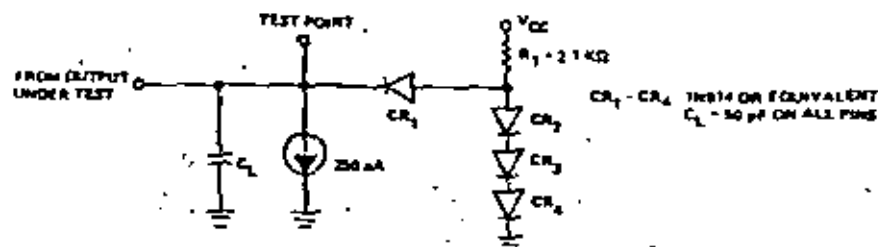

	"1"	"0"
CLOCK	V _{CC} - .6V	.45V
OUTPUT	2.0V	.8V
INPUT	2.0V	.8V
FLOAT	ΔV	±0.5V

Timing measurements are made at the following voltages, unless otherwise specified:

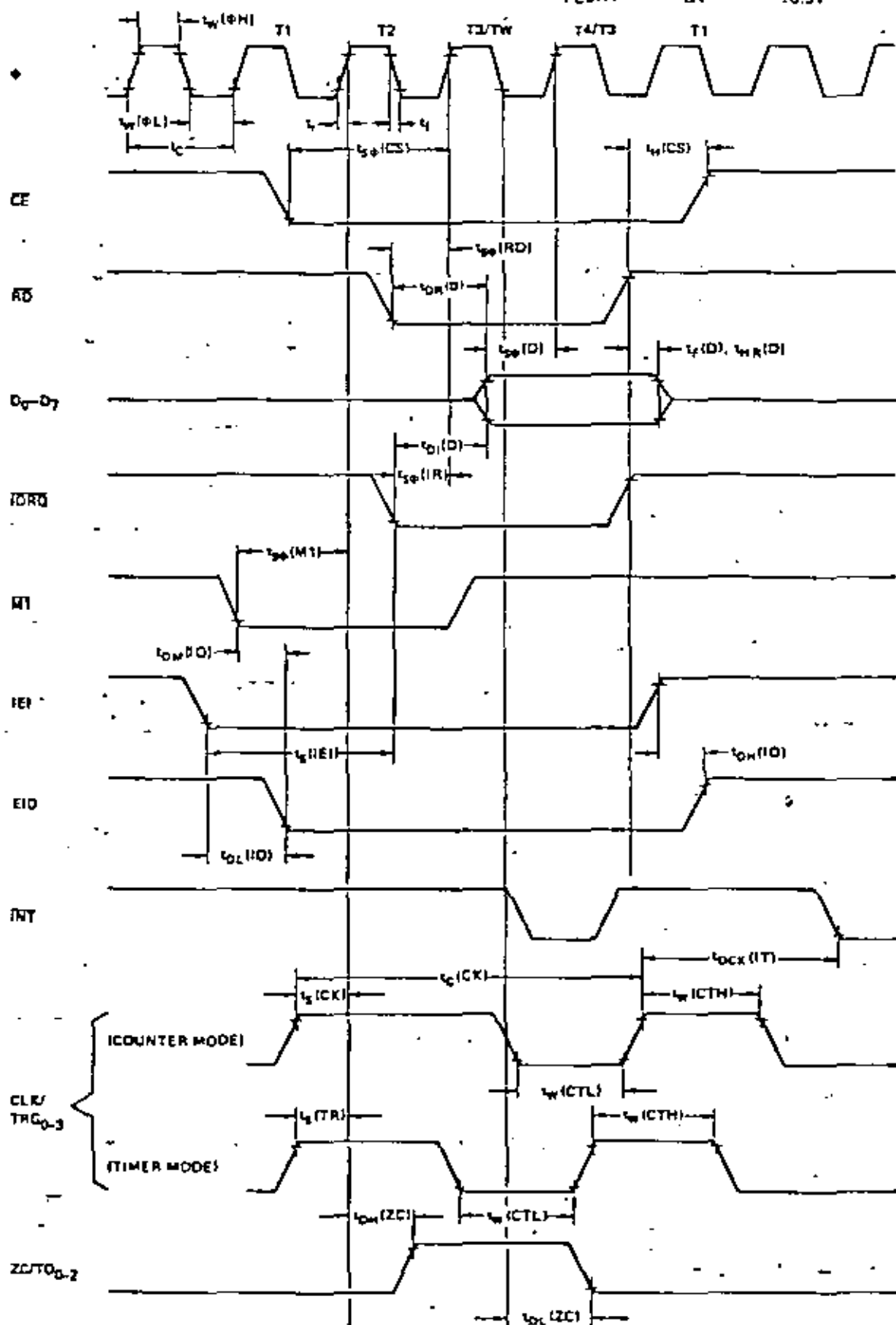

Absolute Maximum Ratings

Temperature Under Bias	0° C to 70° C
Storage Temperature	-65° C to +150° C
Voltage On Any Pin With Respect To Ground	-0.3 V to +7 V
Power Dissipation	0.8W

Comment

Stresses above those listed under "Absolute Maximum Rating" may cause permanent damage to the device. This is a stress rating only and functional operation of the device at these or any other condition above those indicated in the operational sections of this specification is not implied. Exposure to absolute maximum rating conditions for extended periods may affect device reliability.

D.C. Characteristics

TA = 0° C to 70° C, VCC = 5 V ± 0% unless otherwise specified

Z80-CTC

Symbol	Parameter	Min	Max	Unit	Test Condition
V _{ILC}	Clock Input Low Voltage	-0.3	.45	V	I _{OL} = 2 mA I _{OH} = -250 μA T _C = 400 nsec V _{IN} = 0 to V _{CC} V _{OUT} = 2.4 to V _{CC} V _{OUT} = 0.4V V _{EXT} = 1.5V R _{EXT} = 390Ω
V _{IHC}	Clock Input High Voltage (1)	V _{CC} - .6	V _{CC} + .3	V	
V _{IL}	Input Low Voltage	-0.3	0.8	V	
V _{IH}	Input High Voltage	2.0	V _{CC}	V	
V _{OL}	Output Low Voltage		0.4	V	
V _{OH}	Output High Voltage	2.4		V	
I _{CC}	Power Supply Current		120	mA	
I _{LI}	Input Leakage Current		10	μA	
I _{LOH}	Tri-State Output Leakage Current in Float		10	μA	
I _{LOL}	Tri-State Output Leakage Current in Float		-10	μA	
I _{OHD}	Darlington Drive Current	-1.5		mA	

Z80A-CTC

Symbol	Parameter	Min	Max	Unit	Test Condition
V _{ILC}	Clock Input Low Voltage	-0.3	.45	V	I _{OL} = 2 mA I _{OH} = -250 μA T _C = 250 nsec V _{IN} = 0 to V _{CC} V _{OUT} = 2.4 to V _{CC} V _{OUT} = 0.4V V _{EXT} = 1.5V R _{EXT} = 390Ω
V _{IHC}	Clock Input High Voltage (1)	V _{CC} - .6	V _{CC} + .3	V	
V _{IL}	Input Low Voltage	-0.3	0.8	V	
V _{IH}	Input High Voltage	2.0	V _{CC}	V	
V _{OL}	Output Low Voltage		0.4	V	
V _{OH}	Output High Voltage	2.4		V	
I _{CC}	Power Supply Current		120	mA	
I _{LI}	Input Leakage Current		10	μA	
I _{LOH}	Tri-State Output Leakage Current in Float		10	μA	
I _{LOL}	Tri-State Output Leakage Current in Float		-10	μA	
I _{OHD}	Darlington Drive Current	-1.5		mA	

Capacitance

TA = 25° C, f = 1 MHz

Symbol	Parameter	Max.	Unit	Test Condition
C ₀	Clock Capacitance	20	pF	Unmeasured Pins Returned to Ground
C _{IN}	Input Capacitance	5	pF	
C _{OUT}	Output Capacitance	10	pF	

Package Configuration

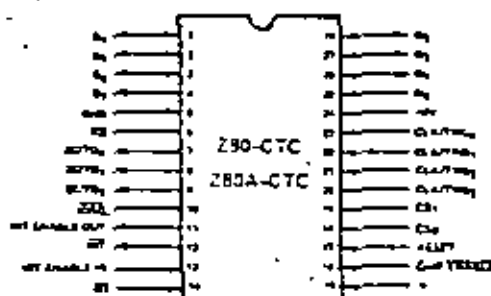

Package Outline

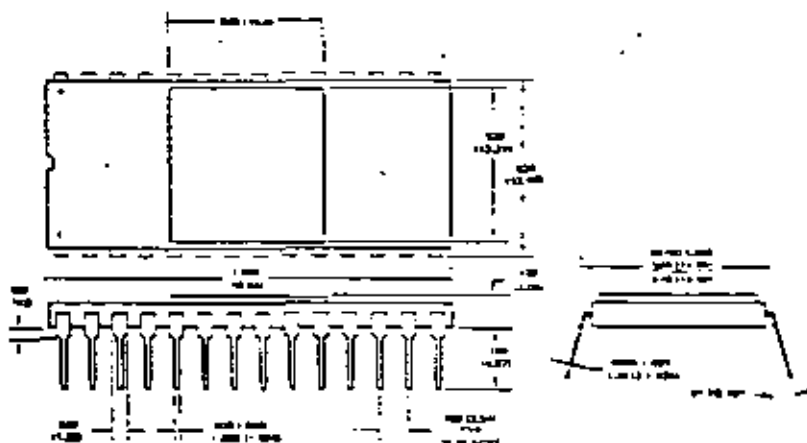

— DIMENSIONS FOR BOTH SYSTEMS ARE GIVEN IN MILLIMETERS

EASTERN

Hallmark Electronics
4719 Commercial Drive
Montville, NJ 08053
TEL 201 437 8700
TWX 810 725 2187

Hallmark Electronics
3302 West McNae Road
Fort Lauderdale, FL 33309
TEL 305 971 9389
TWX 510 956 9720

Hallmark Electronics
Lake Elmore Drive
Cocoa, FL 32909
TEL 305 833 4020
TWX 910 450 0183

Hallmark Electronics
3353 Ardmore Drive
Baltimore, MD 21227
TEL 301 796 4300
TWX 710 362 1942

Hallmark Electronics
1208 Front Street
Building K
Raleigh, NC 27604
TEL 919 832 4445
TWX 510 915 1831

Hallmark Electronics
Pike Industrial Park
Huntington Valley, PA 19006
TEL 215 355 7300
TWX 510 447 1750

Summit
916 Main Street
Buffalo, NY 14202
TEL 716 884 3450

Wilshire Electronics
2234 State Street
Hartford, CT 06117
TEL 203 281 1166
TWX 400 922 1774

Wilshire Electronics
1835 New Highway
Farmersdale, LI, NY 11735
TEL 516 291 5775
TWX 212 895 8707

Wilshire Electronics
One Wilshire Road
Burlington, MA 01803
TEL 617 272 8200
TWX 710 332 6359

Wilshire Electronics
1111 Paulson Avenue
Clifton, NJ 07013
TEL 201 340 1900
TWX 710 949 7053

MIDWESTERN

Hallmark Electronics
180 Cassin Avenue
Evanston, IL 60078
TEL 312 437 8900
TWX 910 223 3643

Hallmark Electronics
11870 West 91st Street
Commerce Industrial Park
Stanhope, NJ 08214
TEL 913 888 4747
TWX 910 249 6670

Hallmark Electronics
9291 Penn Avenue South
Suite 10
Birmingham, AL 35233
TEL 615 884 9036
TWX 910 376 2187

Hallmark Electronics
13789 Rider Trail
Eaton City, MD 63045
TEL 314 291 5330
TWX 910 760 0673

Hallmark Electronics
4969 Washington Casco Road
Washington, OH 43083
TEL 614 846 1882

Hallmark Electronics
4846 S. 33rd E. Avenue
Tulsa, OK 74145
TEL 918 433 8438
TWX 910 845 2290

Hallmark Electronics
2100-A Industrial Terrace
Austin, TX 78758
TEL 512 837 2841
TWX 910 874 2073

Hallmark Electronics
9233 Forest Lane
Dallas, TX 75231
TEL 214 234 7300
TWX 910 367 4323

Hallmark Electronics
6000 Westline
Houston, TX 77063
TEL 713 781 8100
TWX 910 881 2711

Hallmark Electronics
237 South Cullen
Fort Worth, TX 76104
TEL 414 476 1270
TWX 910 262 3164

RM Electronics
4840 South Division
Aurora, IL 60508
TEL 616 531 9300
TWX 810 273 8779

RM Electronics
47 Chestnut Lane
Westmont, Illinois 60359
TEL 312 323 9670

MOUNTAIN

R.V. Weatherford Company
2905 South Mariposa
Englewood, CO 80110
TEL 303 761 2432
TWX 910 933 0173

WESTERN

Insermark Electronics
1807 E. Carnegie Avenue
Santa Ana, CA 92705
TEL 714 540 1322
TWX 910 395 1583

Insermark Electronics
4640 Sorrento Valley Blvd.
San Diego, CA 92121
TEL 714 279 1200
TWX 910 335 4313

Insermark Electronics
1029 Stewart Drive
Sunnyvale, CA 94086
TEL 408 738 1111
TWX 910 339 9312

R.V. Weatherford Co
6922 San Fernando Road
Glendale, CA 91201
TEL 213 849 5451
TWX 910 498 2223

R.V. Weatherford Co
1210 Wabolt Avenue
Anaheim, CA 92805
TEL 714 634 9400
TWX 910 393 3354

R.V. Weatherford Co
1091 East Third Street
Pomona, CA 91765
TEL 714 623 1261
TWX 910 581 3811

R.V. Weatherford Co
2240 Midway Avenue
Stamford Industrial Park
Palo Alto, CA 94304
TEL 415 493 5373

R.V. Weatherford Co
3311 W. 142nd Drive
Phoenicia, AZ 85017
TEL 602 272 0144
TWX 910 951 0636

Sigma Electronics
1400 6th Avenue South
Seattle, WA 98108
TEL 206 742 9100
TEL 32-9652

Western Microelectronics
9770 Bengali Avenue
Sunnyvale, CA 94086
TEL 408 737 1680

CANADA

Future Electronics
5647 Ferner Street
Montreal, Quebec
CANADA H4P 1K1
TEL 514 731 1777
TWX 610 421 3223

EASTERN REGION

Zilog, Inc.
76 Treble Cove Road
No. Billerica, MA 01862
TEL 617 667 2179
TWX 710 347 6660

MIDATLANTIC REGION

Zilog, Inc.
P.O. Box 97
Bergenfield, NJ 07625
TEL 201 365 9158
TWX 710 991 9771

MIDWESTERN REGION

Zilog, Inc.
1701 Woodfield Place
Suite 417
Schaumburg, IL 60195
TEL 312 885 8080
TWX 910 291 1064

SOUTHWESTERN REGION

Zilog, Inc.
17982 Sky Park Circle
Suite C
Irvine, CA 92714
TEL 714 549 2891
TWX 910 595 2803

EUROPEAN HOOTS

Zilog (UK) Ltd.
Nicholson House
Mordenhead, Berkshire
England
TEL (0628) 36131 2's
TWX 848 609

10460 Bubb Road, Cupertino, California 95014

03-0031-01

Telephone: (408) 446-4666 TWX: 910-336-7621

MSE B-38

Printed in U.S.A.
Copyright © 1977 by Zilog, Inc.

Z80[®]-SIO

Z80A-SIO

Product Specification

AUGUST 1978

The Z80-SIO (Serial Input/Output) is a dual-channel multi-function peripheral component designed to satisfy a wide variety of serial data communications requirements in microcomputer systems. Its basic function is a serial-to-parallel, parallel-to-serial converter/controller, but—within that role—it is configurable by systems software so its "personality" can be optimized for a given serial data communications application.

The Z80-SIO is capable of handling asynchronous formats, synchronous byte-oriented protocols such as IBM Bisync, and synchronous bit-oriented protocols such as HDLC and SDLC. This versatile device can also be used to support virtually any other serial protocol for applications other than data communications (cassette or floppy disk interfaces, for example).

The Z80-SIO can generate and check CRC codes in any synchronous mode and can be programmed to check data integrity in various modes. The device also has facilities for modem controls in both channels. In applications where these controls are not needed, the modem controls can be used for general-purpose I/O.

N-channel silicon-gate depletion-load technology

40-pin DIP

Single 5 V power supply

Single-phase 5 V clock

All inputs and outputs TTL compatible

Two independent full-duplex channels

Data rates in synchronous or isosynchronous modes:

- 0-550K bits/second with 2.5 MHz system clock rate
- 0-880K bits/second with 4.0 MHz system clock rate

Receiver data registers quadruply buffered; transmitter doubly buffered.

Asynchronous features:

- 5, 6, 7 or 8 bits/character

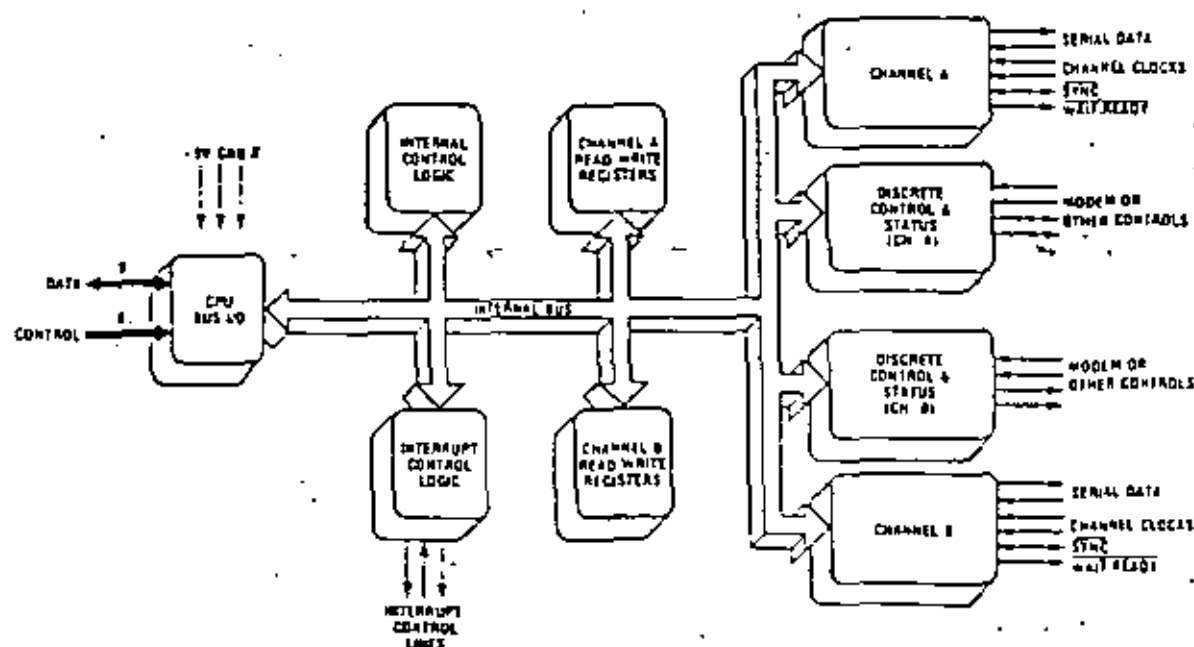

Figure 1. Z80-SIO Block Diagram

- 1, 1½ or 2 stop bits
- Even, odd or no parity
- x1, x16, x32 and x64 clock modes
- Break generation and detection
- Parity, overrun and framing error detection

Binary synchronous features:

- Internal or external character synchronization
- One or two sync characters in separate registers
- Automatic sync character insertion/deletion
- CRC generation and checking

HDLIC and SDLC features:

- Abort sequence generation and detection
- Automatic zero insertion and deletion
- Automatic flag insertion between messages
- Address field recognition
- Support for one to eight bits/character
- Valid receive messages protected from overrun
- CRC generation and checking

Interrupt features:

- Daisy-chain interrupt logic provides automatic interrupt vectoring with no external logic
- Programmable interrupt vector
- Status Affects Interrupt Vector mode for fast interrupt processing

CRC-16 or CRC-CCITT block frame check

Separate modem control inputs and outputs for both channels

Modem status can be monitored

D₀-D₇. System Data Bus (bidirectional, 3-state). The system data bus transfers data and commands between the CPU and the Z80-SIO. D₀ is the least significant bit.

B/A. Channel A Or B Select (input, High selects Channel B). This input defines which channel is accessed during a data transfer between the CPU and the Z80-SIO. Address bit A₀ from the CPU is often used for the selection function.

C/D. Control Or Data Select (input, High selects Control). This input defines the type of information transfer performed between the CPU and the Z80-SIO. A High at this input during a CPU write to the Z80-SIO causes the information on the data bus to be interpreted as a command for the channel selected by B/A. A Low at C/D means that the information on the data bus is data. Address bit A₁ is often used for this function.

CE. Chip Enable (input, active Low). A Low level at this input enables the Z80-SIO to accept command or data input from the CPU during a write cycle, or to transmit data to the CPU during a read cycle.

φ. System Clock (input). The Z80-SIO uses the standard Z80 System Clock to synchronize internal signals. This is a single-phase clock.

M1. Machine Cycle One (input from Z80-CPU, active Low). When M1 is active and RD is also active, the Z80-CPU is fetching an instruction from memory; when M1 is active while WRQ is active, the Z80-SIO accepts M1

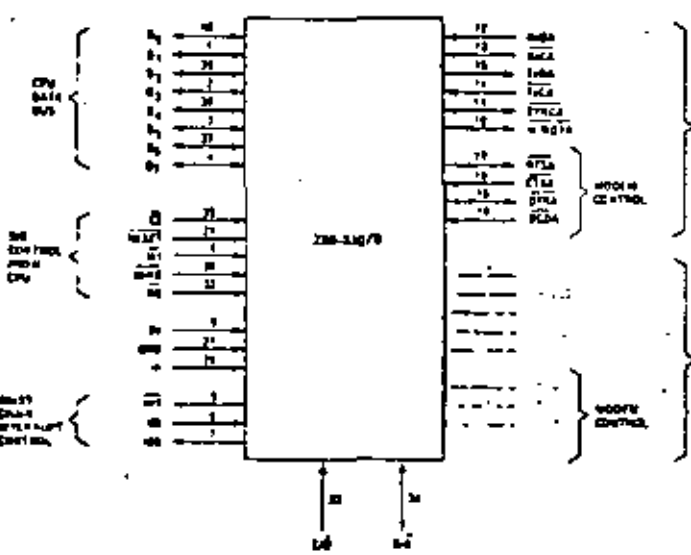

Figure 2. Z80-SIO/0 Pin Configuration

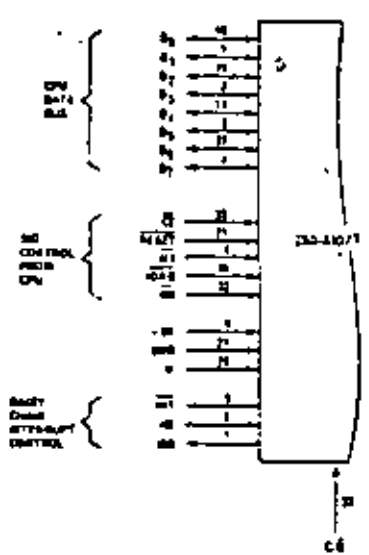

Figure 3.

and \overline{IORQ} as an interrupt acknowledge if the Z80-SIO is the highest priority device that has interrupted the CPU.

\overline{IORQ} . *Input/Output Request* (input from CPU, active Low). \overline{IORQ} is used in conjunction with B/\overline{A} , C/\overline{D} , \overline{CE} and \overline{RD} to transfer commands and data between the CPU and the Z80-SIO. When \overline{CE} , \overline{RD} and \overline{IORQ} are all active, the channel selected by B/\overline{A} transfers data to the CPU (a read operation). When \overline{CE} and \overline{IORQ} are active, but \overline{RD} is inactive, the channel selected by B/\overline{A} is written to by the CPU with either data or control information as specified by C/\overline{D} . As mentioned previously, if \overline{IORQ} and \overline{MI} are active simultaneously, the CPU is acknowledging an interrupt and the Z80-SIO automatically places its interrupt vector on the CPU data bus if it is the highest priority device requesting an interrupt.

\overline{RD} . *Read Cycle Status*. (input from CPU, active Low). If \overline{RD} is active, a memory or I/O read operation is in progress. \overline{RD} is used with B/\overline{A} , \overline{CE} and \overline{IORQ} to transfer data from the Z80-SIO to the CPU.

RESET. *Reset* (input, active Low). A Low RESET disables both receivers and transmitters, forces $TxDATA$ and $TxDEN$ marking, forces the modem controls High and disables all interrupts. The control registers must be rewritten after the Z80-SIO is reset and before data is transmitted or received.

IEI. *Interrupt Enable In* (input, active High). This signal is used with IEO to form a priority daisy chain when there is more than one interrupt-driven device. A High

on this line indicates that no other device of higher priority is being serviced by a CPU interrupt service routine.

IEO. *Interrupt Enable Out* (output, active High). IEO is High only if IEI is High and the CPU is not servicing an interrupt from this Z80-SIO. Thus, this signal blocks lower priority devices from interrupting while a higher priority device is being serviced by its CPU interrupt service routine.

\overline{INT} . *Interrupt Request* (output, open drain, active Low). When the Z80-SIO is requesting an interrupt, it pulls \overline{INT} Low.

$\overline{W/RDYA}$, $\overline{W/RDYB}$. *Wait/Ready A, Wait/Ready B* (outputs, open drain when programmed for Wait function, driven High and Low when programmed for Ready function). These dual-purpose outputs may be programmed as Ready lines for a DMA controller or as Wait lines that synchronize the CPU to the Z80-SIO data rate. The reset state is open drain.

\overline{CTSA} , \overline{CTSB} . *Clear To Send* (inputs, active Low). When programmed as Auto Enables, a Low on these inputs enables the respective transmitter. If not programmed as Auto Enables, these inputs may be programmed as general-purpose inputs. Both inputs are Schmitt-trigger buffered to accommodate slow-risetime signals. The Z80-SIO detects pulses on these inputs and interrupts the CPU on both logic level transitions. The Schmitt-trigger buffering does not guarantee a specified noise-level margin.

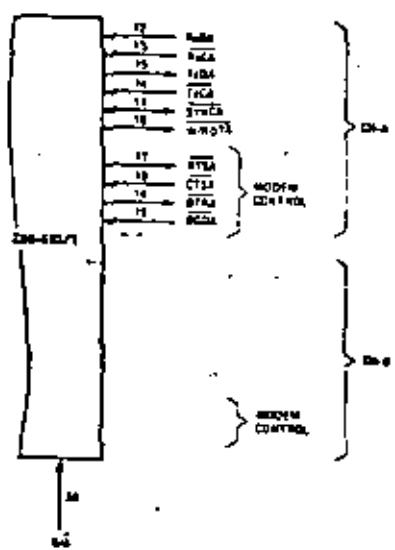

Z80-SIO/1 Pin Configuration

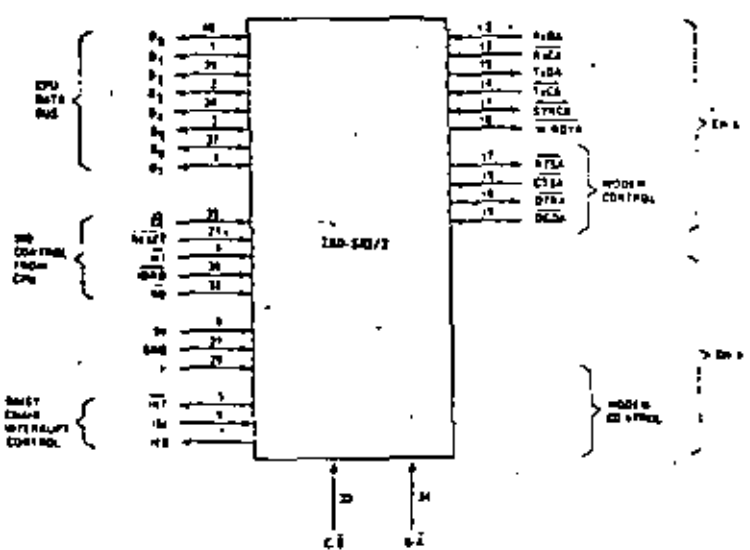

Figure 4. Z80-SIO/2 Pin Configuration

DCDA, DCDB, Data Carrier Detect (inputs, active Low). These pins function as receiver enables if the Z80-SIO is programmed for Auto Enables; otherwise they may be used as general-purpose input pins. Both pins are Schmitt-trigger buffered to accommodate slow-risetime signals. The Z80-SIO detects pulses on these pins and interrupts the CPU on both logic level transitions. Schmitt-trigger buffering does not guarantee a specific noise level margin.

RxDA, RxDB, Receive Data (inputs, active High).

TxDA, TxDB, Transmit Data (outputs, active High).

RxCA, RxCB, Receiver Clocks (inputs). Receive data is sampled on the rising edge of RxC . The Receive Clocks may be 1, 16, 32 or 64 times the data rate in Asynchronous modes. These clocks may be driven by the Z80-CTC Counter Timer Circuit for programmable baud rate generation. Both inputs are Schmitt-trigger buffered (no noise level margin is specified). See the following section for bonding options.

TxCA, TxCB, Transmitter Clocks (inputs). TxD changes on the falling edge of TxC . In Asynchronous modes, the Transmitter Clocks may be 1, 16, 32 or 64 times the data rate; however, the clock multiplier for the transmitter and the receiver must be the same. The Transmit Clock inputs are Schmitt-trigger buffered for relaxed rise- and fall-time requirements (no noise level margin is specified). Transmitter Clocks may be driven by the Z80-CTC Counter Timer Circuit for programmable baud rate generation. See the following section for bonding options.

RTSA, RTSB, Request To Send (outputs, active Low). When the RTS bit is set, the RTS output goes Low. When the RTS bit is reset in the Asynchronous mode, the output goes High after the transmitter is empty. In Synchronous modes, the RTS pin strictly follows the state of the RTS bit. Both pins can be used as general-purpose outputs.

DTRA, DTRB, Data Terminal Ready (outputs, active Low). See note on bonding options. These outputs follow the state programmed into the DTR bit. They can also be programmed as general-purpose outputs.

SYNC A, SYNC B, Synchronization (inputs/outputs, active Low). These pins can act either as inputs or outputs. In the Asynchronous Receive mode, they are inputs similar to CTS and DCD . In this mode, the transitions on these lines affect the state of the Sync/Hunt status bits in $\ast RD$. In the External Sync mode, these lines also act as inputs. When external synchronization is achieved, $SYNC$ must be driven Low on the second rising edge of RxC after that rising edge of RxC on which the last bit of the sync character was received. In other words, after the sync pattern is detected, the external logic must wait for two full Receive Clock cycles to activate the $SYNC$ input. Once $SYNC$ is forced Low, it is wise to keep it Low until the CPU informs the external sync logic that synchronization has been lost or a new mes-

sage is about to start. Character assembly begins on the rising edge of RxC that immediately precedes the falling edge of $SYNC$ in the External Sync mode.

In the Internal Synchronization mode (Monosync and Bisync), these pins act as outputs that are active during the part of the receive clock (RxC) cycle in which sync characters are recognized. The sync condition is not latched, so these outputs are active each time a sync pattern is recognized, regardless of character boundaries.

The constraints of a 40-pin package make it impossible to bring out the Receive Clock, Transmit Clock, Data Terminal Ready and Sync signals for both channels. Therefore, Channel B must sacrifice a signal or have two signals bonded together. Since user requirements vary, three bonding options are offered:

- Z80-SIO/0 has all four signals, but $TxCB$ and $RxCB$ are bonded together (Fig. 2).
- Z80-SIO/1 sacrifices DTRB and keeps $TxCB$, $RxCB$ and $SYNCB$ (Fig. 3).
- Z80-SIO/2 sacrifices $SYNCB$ and keeps $TxCB$, $RxCB$ and $DTRB$ (Fig. 4).

The device internal structure includes a Z80-CPU interface, internal control and interrupt logic, and two full-duplex channels. Each channel contains read and write registers, and discrete control and status logic that provides the interface to modems or other external devices.

The read and write register group includes five 8-bit control registers, two sync-character registers and two status registers. The interrupt vector is written into an additional 8-bit register (Write Register 2) in Channel B that may be read through Read Register 2 in Channel B. The registers for both channels are designated in the text as follows:

- WR0-WR7 — Write Registers 0 through 7
- RR0-RR2 — Read Registers 0 through 2

The bit assignment and functional grouping of each register is configured to simplify and organize the programming process. Table 1 lists the functions assigned to each read or write register.

RR0	Transmit/Receive buffer status, interrupt status and external status
RR1	Special Receive Condition status
RR2	Modified interrupt vector (Channel B only)

Read Register Functions

WR0	Register pointers, CRC initialize, initialization commands for the various modes, etc.
WR1	Transmit/Receive interrupt and data transfer mode definition.
WR2	Interrupt vector (Channel B only)
WR3	Receive parameters and control
WR4	Transmit/Receive miscellaneous parameters and modes
WR5	Transmit parameters and controls
WR6	Sync character or SDLC address field
WR7	Sync character or SDLC flag

Write Register Functions

Table 1. Functional Assignments of Read and Write Registers

The logic for both channels provides formats, synchronization and validation for data transferred to and from the channel interface. The modem control inputs Clear to Send (CTS) and Data Carrier Detect (DCD) are monitored by the discrete control logic under program control. All the modem control signals are general purpose in nature and can be used for functions other than modem control.

For automatic interrupt vectoring, the interrupt control logic determines which channel and which device within the channel has the highest priority. Priority is fixed with Channel A assigned a higher priority than Channel B; Receive, Transmit and External/Status interrupts are prioritized in that order within each channel.

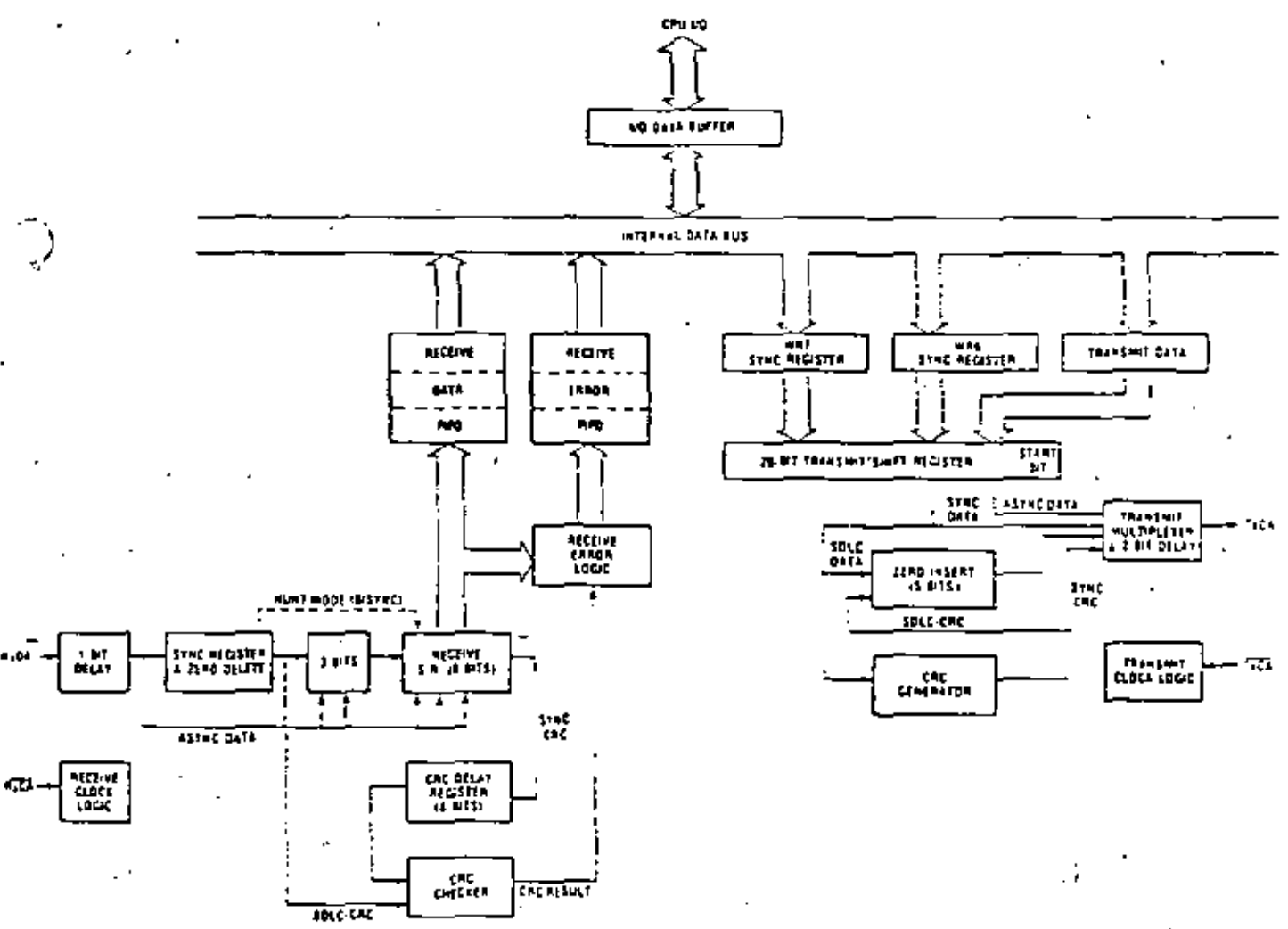

Figure 5. Transmit and Receive Data Path

The transmit and receive data path illustrated for Channel A in Figure 5 is identical for both channels. The receiver has three 8-bit buffer registers in a FIFO arrangement in addition to the 8-bit receive shift register. This scheme creates additional time for the CPU to service an interrupt at the beginning of a block of high-speed data. Incoming data is routed through one of several paths (data or CRC) depending on the selected mode and—in Asynchronous modes—the character length.

The transmitter has an 8-bit transmit data register that is loaded from the internal data bus, and a 20-bit transmit shift register that can be loaded from the sync character buffers (WR6 and WR7) or from the transmit data register. Depending on the operational mode, outgoing data is routed through one of four main paths before it is transmitted from the Transmit Data Output (TDO).

The functional capabilities of the Z80-SIO can be described from two different points of view: as a data communications device, it transmits and receives serial data, and meets the requirements of various data communications protocols; as a Z80 family peripheral, it interacts with the Z80-CPU and other Z80 peripheral devices, and shares the data, address and control buses, as well as being a part of the Z80 interrupt structure. As a peripheral to other microprocessors, the Z80-SIO offers valuable features such as non-vectorized interrupts, polling and simple handshake capability.

The first part of the following functional description describes the interaction between the CPU and Z80-SIO; the second part introduces its data communications capabilities.

The Z80-SIO offers the choice of Polling, Interrupt (vectored or non-vectored) and Block Transfer modes to transfer data, status and control information to and from the CPU. The Block Transfer mode can be implemented under CPU or DMA control.

Polling. There are no interrupts in the Polled mode. Status registers RR0 and RR1 are updated at appropriate times for each function being performed (for example, CRC Error status valid at the end of the message). All the interrupt modes of the Z80-SIO must be disabled to operate the device in a polled environment.

While in its Polling sequence, the CPU examines the status contained in RR0 for each channel; the RR0 status bits serve as an acknowledge to the Poll inquiry. The two RR0 status bits D₀ and D₂ indicate that a data transfer is needed. The status also indicates Error or

other special status conditions (see "Z80-SIO Programming"). The Special Receive Condition status contained in RR1 does not have to be read in a Polling sequence because the status bits in RR1 must be accompanied by a Receive Character Available status in RR0.

Interrupts. The Z80-SIO offers an elaborate interrupt scheme to provide fast interrupt response in real-time applications. Channel B registers WR2 and RR2 contain the interrupt vector that points to an interrupt service routine in the memory. To service operations in both channels and to eliminate the necessity of writing a status analysis routine, the Z80-SIO can modify the interrupt vector in RR2 so it points directly to one of eight interrupt service routines. This is done under program control by setting a program bit (WR1, D₇) in Channel B called "Status Affects Vector." When this bit is set, the interrupt vector in WR2 is modified according to the assigned priority of the various interrupting conditions. The table in the Write Register 1 description (Z80-SIO Programming section) shows the modification details.

Transmit interrupts, Receive interrupts and External/Status interrupts are the main sources of interrupts. Each interrupt source is enabled under program control with Channel A having a higher priority than Channel B, and with Receiver, Transmit and External/Status interrupts prioritized in that order within each channel. When the Transmit interrupt is enabled, the CPU is interrupted by the transmit buffer becoming empty. (This implies that the transmitter must have had a data character written into it so it can become empty.) When enabled, the receiver can interrupt the CPU in one of three ways:

- Interrupt on the first received character
- Interrupt on all received characters
- Interrupt on a Special Receive condition

Interrupt On First Character is typically used with the Block Transfer mode. Interrupt On All Receive Characters has the option of modifying the interrupt vector in the event of a parity error. The Special Receive Condition interrupt can occur on a character or message basis (End Of Frame interrupt in SDLC, for example). The Special Receive condition can cause an interrupt only if the Interrupt On First Receive Character or Interrupt On All Receive Characters mode is selected. In Interrupt On First Receive Character, an interrupt can occur from Special Receive conditions (except Parity Error) after the first receive character interrupt (example: Receive Overrun interrupt).

The main function of the External Status interrupt is to monitor the signal transitions of the CT3, DCB and SYNC pins; however, an External/Status interrupt is also caused by a Transmit Underrun condition or by the detection of a Break (Asynchronous mode) or Abort (SDLC mode) sequence in the data stream. The interrupt caused by the Break/Abort sequence has a special feature that allows the Z80-SIO to interrupt when the Break/Abort sequence is detected or terminated. This feature facilitates the proper termination of the current message, correct initialization of the next message, and

the accurate timing of the Break/Abort condition in external logic.

CPU/DMA Block Transfer. The Z80-SIO provides a Block Transfer mode to accommodate CPU block transfer functions and DMA controllers (Z80-DMA or other designs). The Block Transfer mode uses the WAIT/READY output in conjunction with the Wait/Ready bits of Write Register 1. The WAIT/READY output can be defined under software control as a WAIT line in the CPU Block Transfer mode or as a READY line in the DMA Block Transfer mode.

To a DMA controller, the Z80-SIO READY output indicates that the Z80-SIO is ready to transfer data to or from memory. To the CPU, the WAIT output indicates that the Z80-SIO is not ready to transfer data, thereby requesting the CPU to extend the I/O cycle. The programming of bits 5, 6 and 7 of Write Register 1 and the logic states of the WAIT/READY line are defined in the Write Register 1 description (Z80-SIO Programming section).

In addition to the I/O capabilities previously discussed, the Z80-SIO provides two independent full-duplex channels that can be programmed for use in Asynchronous, Synchronous and SDLC (HDLC) modes. These different modes are provided to facilitate the implementation of commonly used data communications protocols. The following is a short description of the data communications protocols supported by the Z80-SIO. A more detailed explanation of these modes can be found in the *Z80-SIO Technical Manual*.

Asynchronous Modes. The Z80-SIO offers transmission and reception of five to eight bits per character, plus optional even or odd parity. The transmitter can supply one, one and a half or two stop bits per character and can provide a break output at any time. The receiver break detection logic interrupts the CPU only at the start and end of a received break. Reception is protected from spikes by a transient spike rejection mechanism that checks the signal one-half a bit time after a Low level is detected on the Receive Data input. If the Low does not persist—as in the case of a transient—the character assembly process is not started.

Framing errors and overrun errors are detected and buffered together with the partial character on which they occurred. Vectored interrupts allow fast servicing of error conditions using dedicated routines. Furthermore, a built-in checking process avoids interpreting a framing error as a new start bit: a framing error results in the addition of one-half a bit time to the point at which the search for the next start bit is begun.

The Z80-SIO does not require symmetric Transmit and Receive Clock signals—a feature that allows it to be used with a Z80-CTC or any other clock source. The transmitter and receiver can handle data at a rate of 1,

1/16, 1/32 or 1/64 of the clock rate supplied to the Receive and Transmit Clock inputs.

In Asynchronous modes, the SYNC pin may be programmed for an input that can be used for functions such as monitoring a ring indicator.

Synchronous Modes. The Z80-SIO supports both byte-oriented and bit-oriented synchronous communication. Synchronous byte-oriented protocols can be handled in several modes that allow character synchronization with an 8-bit sync character (Monosync), any 16-bit sync pattern (Bisync), or with an external sync signal. Leading sync characters can be removed without interrupting the CPU. CRC checking for synchronous byte-oriented modes is delayed by one character time so the CPU may disable CRC checking on specific characters. This permits implementation of protocols such as IBM Bisync.

Both CRC-16 ($X^{16} + X^{12} + X^2 + 1$) and CCITT ($X^{16} + X^{12} + X^5 + 1$) error checking polynomials are supported. In all non-SDLC modes, the CRC generator is initialized to 0's; in SDLC modes, it is initialized to 1's. (This means that the Z80-SIO cannot generate or check CRC for IBM-compatible soft-sectored disks.) The Z80-SIO also provides a feature that automatically transmits CRC data when no other data is available for transmission. This allows very high-speed transmissions under DMA control with no need for CPU intervention at the end of a message. When there is no data or CRC to send in Synchronous modes, the transmitter inserts 8- or 16-bit sync characters regardless of the programmed character length. Since the CPU can read status information from the Z80-SIO, it can determine the type of transmission (data, CRC or sync characters) that is taking place at any time.

The Z80-SIO supports synchronous bit-oriented protocols such as SDLC and HDLC by performing automatic flag sending, zero insertion and CRC generation. A special command can be used to abort a frame in transmission. The Z80-SIO automatically transmits the CRC and trailing flag when the transmit buffer becomes empty. An interrupt warns the CPU of this status change so an abort may be issued if a transmitter underrun has occurred. One to eight bits per character can be sent, which allows transmission of a message exactly as received with no prior information about the character structure in the information field of a frame.

The receiver automatically synchronizes on the leading flag of a frame and provides a synchronization signal that can be programmed to interrupt. In addition, an interrupt on the first received character or on every character can be selected. The receiver automatically deletes all zeroes inserted by the transmitter during character assembly. It also calculates and automatically checks the CRC to validate frame transmission. At the end of transmission, the status of a received frame is available in the status registers. The receiver can be programmed to search for frames addressed to only a specified user-selectable address or to a global broadcast address. In this mode, frames that do not match the user-

selected or broadcast address are ignored. The Address Search mode provides for a single-byte address recognizable by the hardware. The number of address bytes be extended under software control.

The Z80-SIO can be conveniently used under DMA control to provide high-speed reception. The Z80-SIO can interrupt the CPU when the first character of a message is received. The CPU then enables the DMA to transfer the message to memory. The Z80-SIO then issues an End Of Frame interrupt and the CPU checks the status of the received message. Thus, the CPU is freed for other service while the message is being received. A similar scheme allows message transmission under DMA control.

To program the Z80-SIO, the system program first issues a series of commands that initialize the basic mode of operation and then other commands that qualify conditions within the selected mode. For example, the Asynchronous mode, character length, clock rate, number of stop bits, even or odd parity are first set, then the interrupt mode and, finally, receiver or transmitter enable. The WRA parameters must be issued before any other parameters are issued in the initialization routine.

Both channels contain command registers that must be programmed via the system program prior to operation. The Channel Select input (B/A) and the Control/Data input (C/D) are the command structure addressing controls, and are normally controlled by the CPU address bus. Figure 8 illustrates the timing relationships for programming the write registers, and transferring data and status.

The Z80-SIO contains eight registers (WR0-WR7) in each channel that are programmed separately by the system program to configure the functional personality of the channels. With the exception of WR0, programming the write registers requires two bytes. The first byte contains three bits (D0-D2) that point to the selected register; the second byte is the actual control word that is written into the register to configure the Z80-SIO.

WR0 is a special case in that all the basic commands (CMD0-CMD3) can be accessed with a single byte. Reset (internal or external) initializes the pointer bits D0-D2 to point to WR0.

The Z80-SIO contains three registers, RR0-RR2 (Figure 6), that can be read to obtain the status information for each channel (except for RR2 - Channel B only). The

status information includes error conditions, interrupt vector and standard communications-interface signals.

To read the contents of a selected read register other than RR0, the system program must first write the pointer byte to WR0 in exactly the same way as a write register operation. Then, by executing an input instruction, the contents of the addressed read register can be read by the CPU.

The status bits of RR0 and RR1 are carefully grouped to simplify status monitoring. For example, when the interrupt vector indicates that a Special Receive Condition interrupt has occurred, all the appropriate error bits can be read from a single register (RR1).

READ REGISTER 0

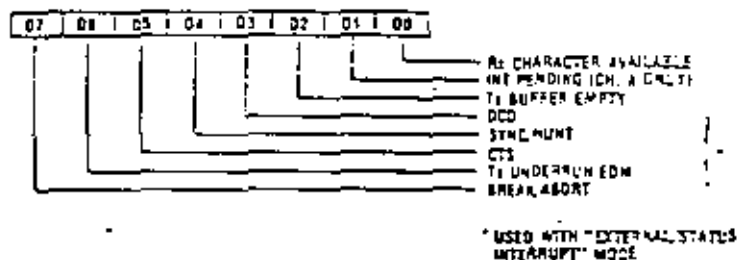

READ REGISTER 1†

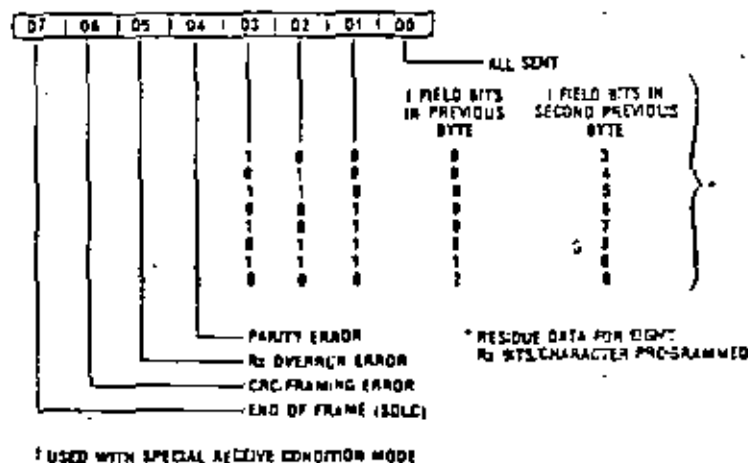

READ REGISTER 2

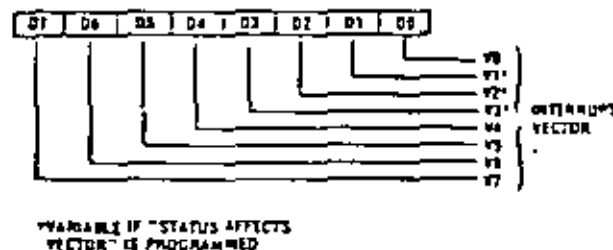

Figure 6. Read Register Bit Functions

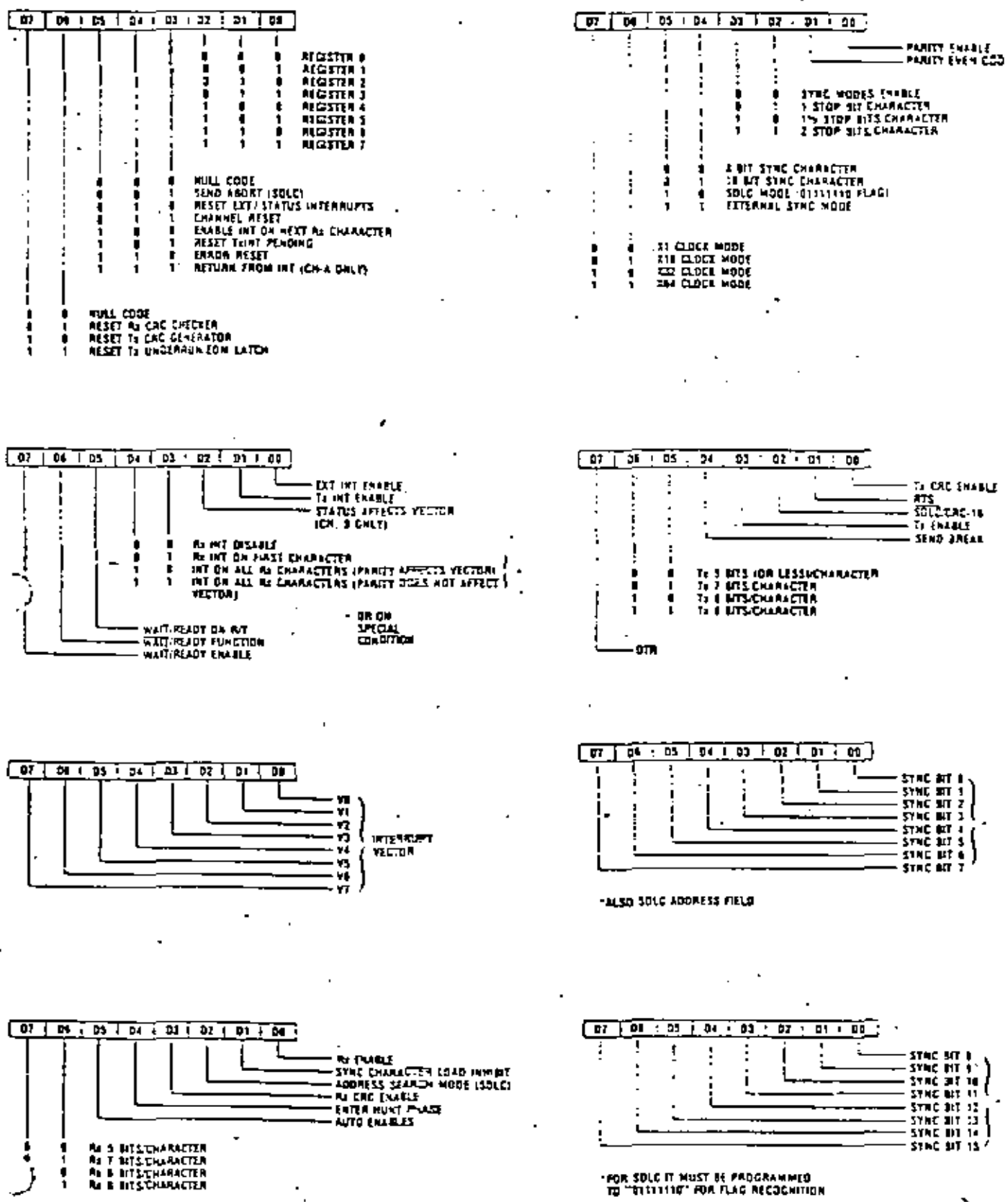

Figure 7. Write Register Bit Functions

Read Cycle. The timing signals generated by a Z80-CPU input instruction to read a Data or Status byte from the Z80-SIO are illustrated in Figure 8a.

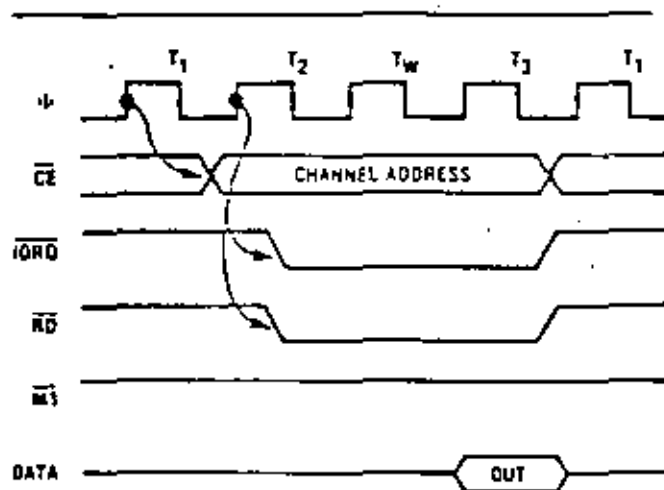

Figure 8a. Read Cycle

Write Cycle. Figure 8b illustrates the timing and data signals generated by a Z80-CPU output instruction to write a Data or Control byte into the Z80-SIO.

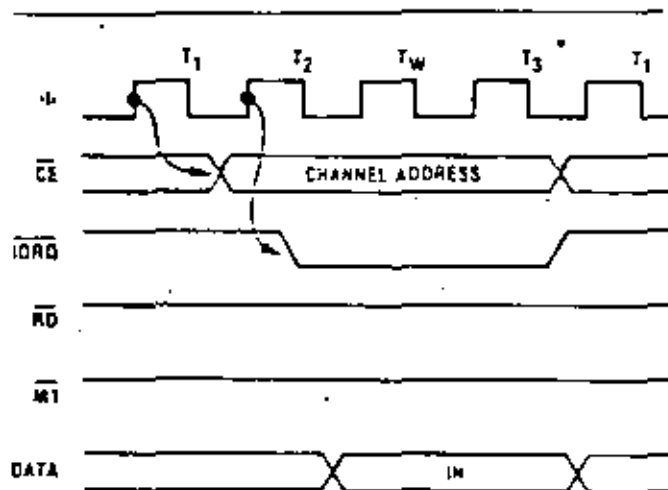

Figure 8b. Write Cycle

Interrupt Acknowledge Cycle. After receiving an Interrupt Request signal (\overline{INT} pulled Low), the Z80-CPU sends an interrupt Acknowledge signal (\overline{INT} and \overline{IORQ} both Low). The daisy-chained interrupt circuits determine the highest priority interrupt requestor. The \overline{IEI} of the highest priority peripheral is terminated High. For any peripheral that has no interrupt pending or under service, $\overline{IEO} = \overline{IEI}$. Any peripheral that does have an interrupt pending or under service forces its \overline{IEO} Low.

To insure stable conditions in the daisy chain, all interrupt status signals are prevented from changing while $\overline{M1}$ is Low. When \overline{IORQ} is Low, the highest priority interrupt requestor (the one with \overline{IEI} High) places its interrupt vector on the data bus and sets its internal interrupt-under-service latch.

Return From Interrupt Cycle. Normally, the Z80-CPU issues a RETI (RETURN FROM INTERRUPT) instruction at the end of an interrupt service routine. RETI is a 2-byte opcode (ED-4D) that resets the interrupt-under-service latch to terminate the interrupt that has just been processed. This is accomplished by manipulating the daisy chain in the following way.

The normal daisy chain operation can be used to detect a pending interrupt; however, it cannot distinguish between an interrupt under service and a pending unacknowledged interrupt of a higher priority. Whenever "ED" is decoded, the daisy chain is modified by forcing High the \overline{IEO} of any interrupt that has not yet been acknowledged. Thus the daisy chain identifies the device presently under service as the only one with an \overline{IEI}

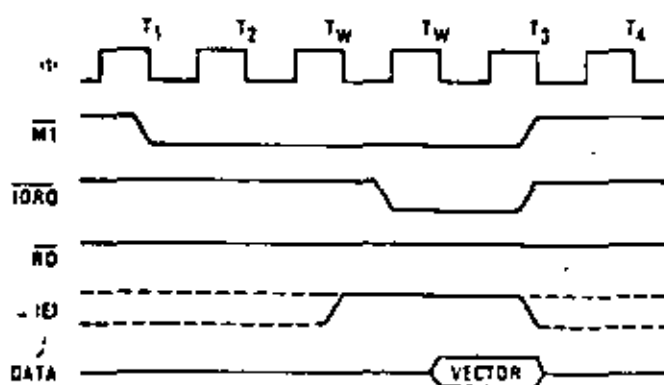

Figure 8c. Interrupt Acknowledge Cycle

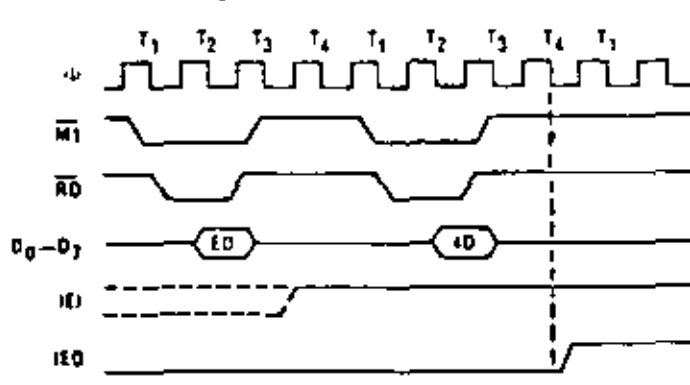

Figure 8d. Return from Interrupt Cycle

High and an IEO Low. If the next opcode byte is "40," the interrupt-under-service latch is reset.

The ripple time of the interrupt daisy chain (both the High-to-Low and the Low-to-High transitions) limits the number of devices that can be placed in the daisy chain. Ripple time can be improved with carry-look-ahead, or by extending the interrupt acknowledge cycle. For further information about techniques for increasing the number of daisy-chained devices, refer to Zilog Application Note 03-0041-01 (*The Z80 Family Program Interrupt Structure*).

Figure 9 illustrates the daisy chain configuration of interrupt circuits and their behavior with nested inter-

rupts (an interrupt that is interrupted by another with a higher priority).

Each box in the illustration could be a separate external Z80 peripheral circuit with a user-defined order of interrupt priorities. However, a similar daisy chain structure also exists inside the Z80-SIO, which has six interrupt levels with a fixed order of priorities.

The case illustrated occurs when the transmitter of Channel B interrupts and is granted service. While this interrupt is being serviced, it is interrupted by a higher priority interrupt from Channel A. The second interrupt is serviced and—upon completion—a RETI instruction is executed or a RETI command is written into the Z80-SIO, resetting the interrupt-under-service latch of the Channel A interrupt. At this time, the service routine for Channel B is resumed. When it is completed, another RETI instruction is executed to complete the interrupt service.

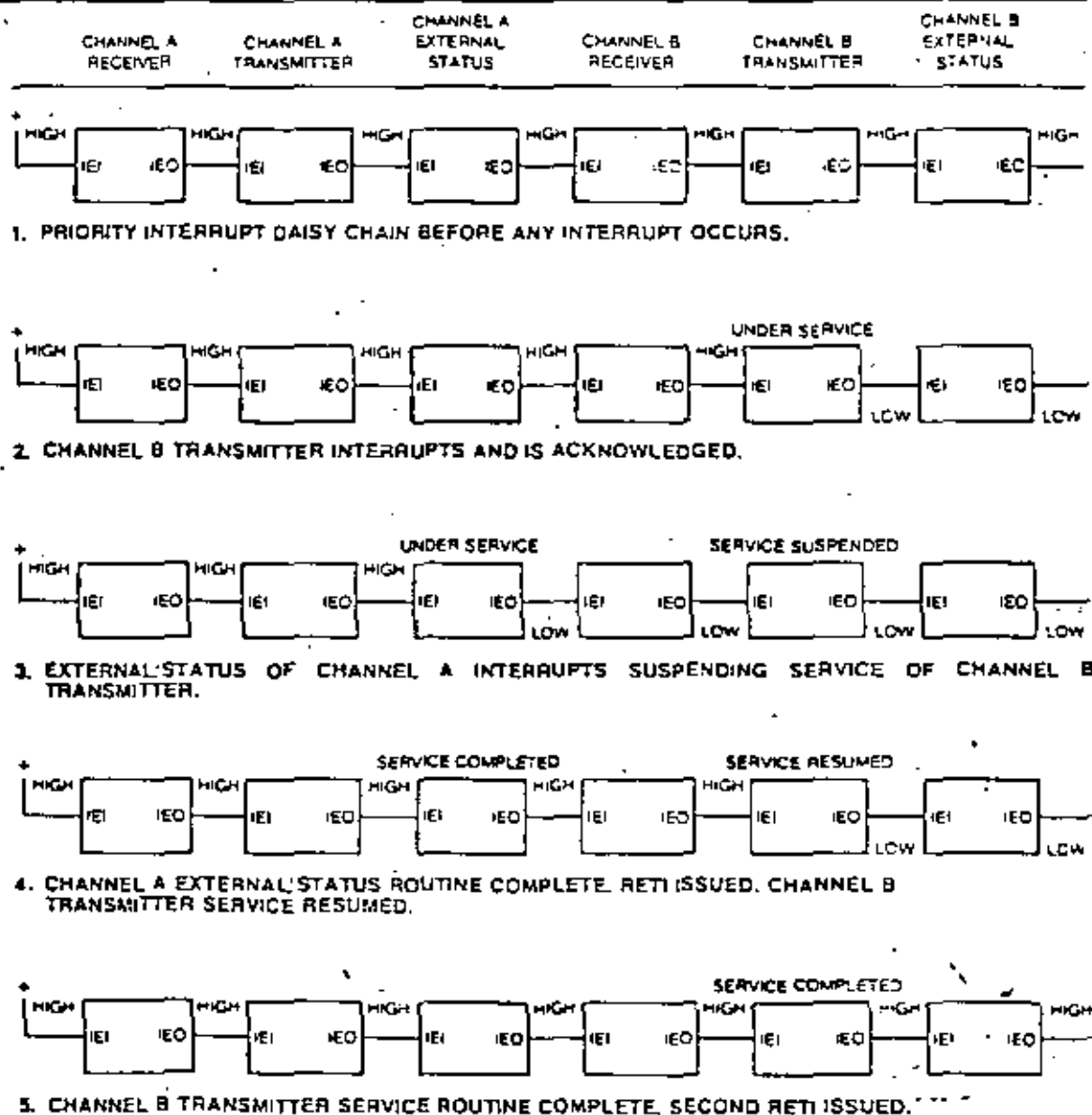
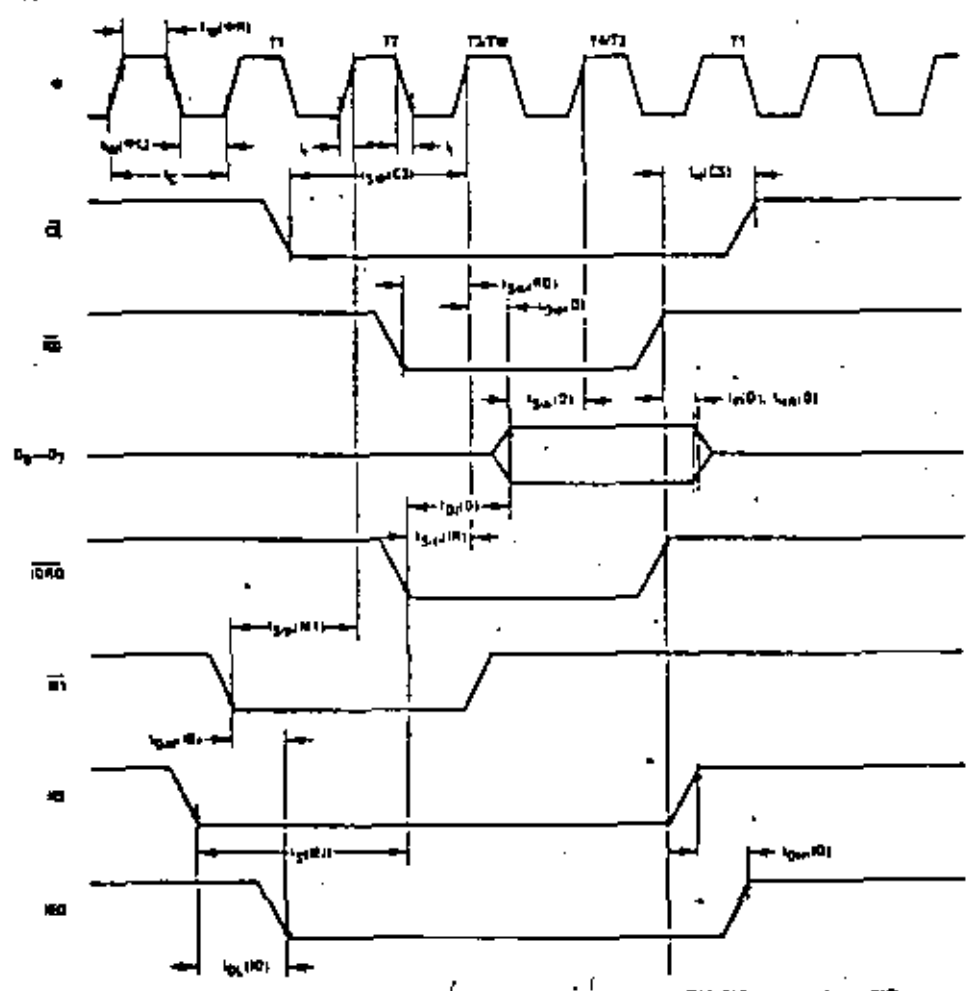

Figure 9. Typical Interrupt Sequence

T_A = 0°C, V_{CC} = +5V, ±5%



Signal	Symbol	Parameter	280-S10		280A-S10		Unit
			Min	Max	Min	Max	
•	t _{clk}	Clock Period	400	4000	250	4000	ns
	t _{clkPH}	Clock Pulse Width, clock HIGH	170	2000	100	2000	ns
	t _{clkPL}	Clock Pulse Width, clock LOW	170	2000	100	2000	ns
	t _{clk}	Clock Rise and Fall Times	0	30	0	30	ns
	t _u	Any Unspecified Hold Time for signal lines specified below	0		0		ns
CE, BA, CD, RDQ	t _{CS}	Control Signal Setup Time to rising edge of a during Read or Write Cycle	180		145		ns
D, D _Q	t _{DO}	Data Output Delay from rising edge of a during Read Cycle		240		220	ns
	t _{DI}	Data Setup Time to rising edge of a during Write or M1 Cycle	50		50		ns
	t _{DD}	Data Output Delay from rising edge of RDQ during MTA Cycle		340		180	ns
	t _{DD}	Delay to Floating Bus (output buffer disable time)		230		110	ns
WE	t _{WE}	WE Setup Time to rising edge of RDQ during MTA Cycle	200		140		ns
EO	t _{EO}	EO Delay Time from rising edge of WE (after ED decode)		150		100	ns
	t _{EO}	EO Delay Time from rising edge of WE		150		100	ns
	t _{EO}	EO Delay Time from rising edge of M1 interrupt occurring just prior to M1		200		180	ns
M1	t _{M1}	M1 Setup Time to rising edge of a during MTA or M1 Cycle	210		90		ns
M2	t _{M2}	M2 Setup Time to rising edge of a during Read or M1 Cycle	240		115		ns

*If WAIT from the S10 is to be used, CE, RDQ, CD and M1 must be valid for as long as the WAIT read cycle as to permit.

Figure 9. Typical Interrupt Sequence



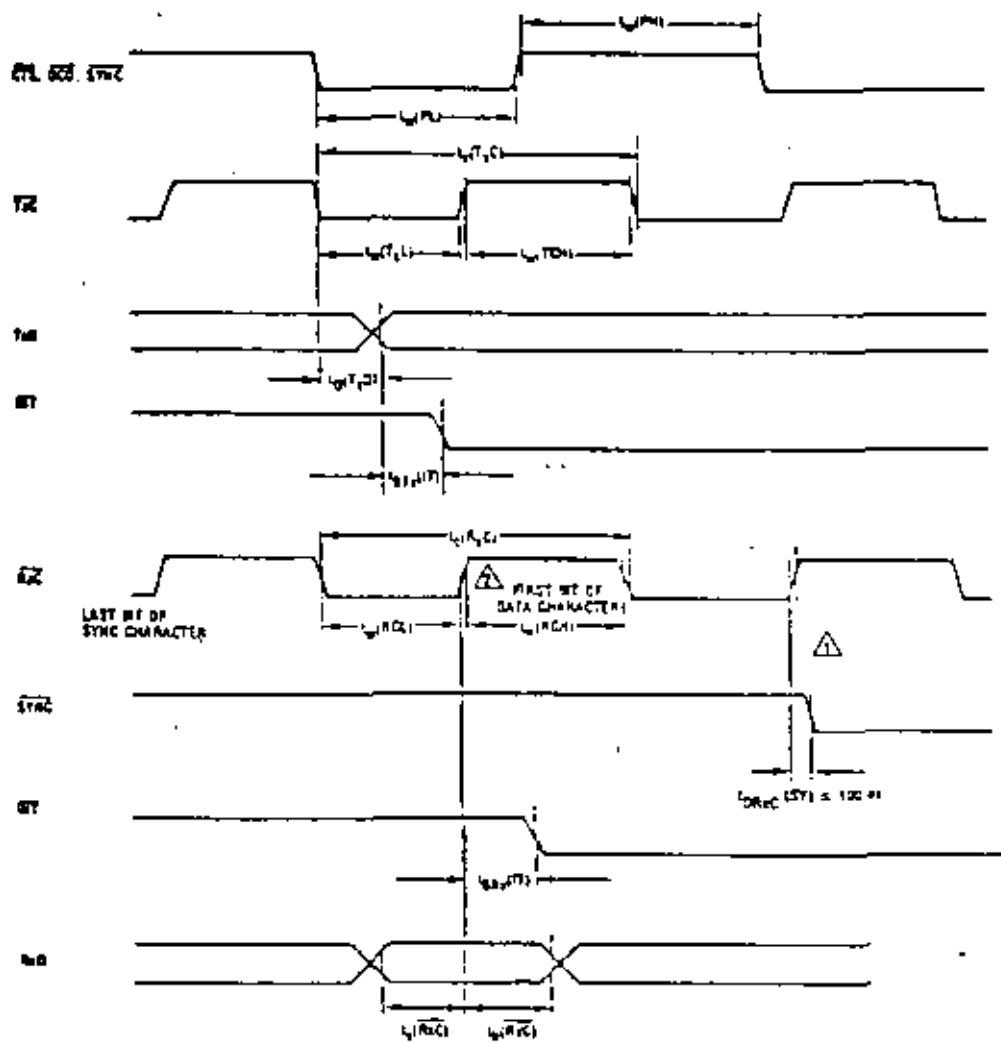

NOTES:

1. The SYNC input must be driven Low on the rising edge of RxC delayed two complete clock cycles from the last bit of the sync character.
2. Data character assembly begins on the next Active Clock cycle after the last bit of the sync character is received.

Signal	Symbol	Parameter	Z80-B70		Z80A-340		Unit
			Min	Max	Min	Max	
BT	$t_{d(BT)}$	BT Delay Time from rising edge of RxC	10	13	10	13	n-pulses
	$t_{d(BT)}$	BT Delay Time from transition of STWC Data bit	5	3	5	9	n-pulses
CSA, CSB CSA, CSB STWC, STWC	$t_{p(H)}$	Minimum HIGH Pulse Width for latching state into register and generating interrupt	200		200		ns
	$t_{p(L)}$	Minimum LOW Pulse Width for latching state into register and generating interrupt	200		200		ns
STWC, STWC	$t_{d(SY)}$	Sync Phase Delay Time from rising edge of RxC Output Mode	4	7	4	7	n-pulses
	$t_{d(SY)}$	Sync Phase Delay Time from rising edge of RxC External Sync Mode		100		100	ns
TRC, TRC	$t_{p(C)}$	Transmit Clock Period	400	=	400	=	ns
	$t_{p(C)}$	Transmit Clock Pulse Width (with data HIGH)	180	=	180	=	ns
	$t_{p(C)}$	Transmit Clock Pulse Width (with data LOW)	180	=	180	=	ns
TdO, TdO'	$t_{d(O)}$	TdO Output Delay from rising Edge of TRC (all Clock Modes)		400		300	ns
RdC, RdC	$t_{p(C)}$	Receive Clock Period	400	=	400	=	ns
	$t_{p(C)}$	Receive Clock Pulse Width (with data HIGH)	180	=	180	=	ns
	$t_{p(C)}$	Receive Clock Pulse Width (with data LOW)	180	=	180	=	ns
RdA, RdA'	$t_{s(A)}$	Setup Time to rising edge of RxC (1st mode)	0		0		ns
	$t_{h(A)}$	Hold Time from rising edge of RxC (1st mode)	140		140		ns

*In all modes, the system clock rate must be at least 4.5 times the maximum data rate. RESET must be active a minimum of one complete cycle.

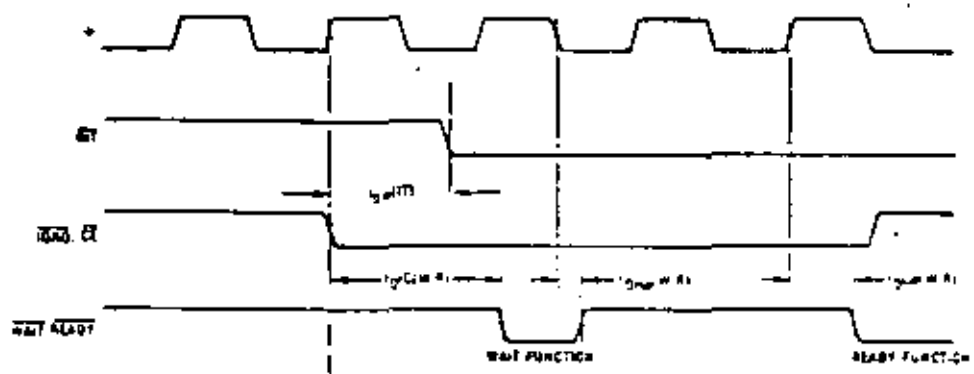

Signal	Symbol	Parameter	256-BIO		2048-BIO		Unit
			Min	Max	Min	Max	
ST	t _{pd}	ST Delay Time from rising edge of ϕ		200	200	ns	
	t _{pdmax}	WAIT READY Delay Time from \overline{CE} or \overline{OE} in Wait Mode		180	130	ns	
	t _{pdmin}	WAIT READY Delay Time from falling edge of ϕ in WAIT READY Wait Mode		150	130	ns	
WAIT READY	t _{pdmax}	WAIT READY Delay Time from rising edge of ϕ , Data Bit Ready Mode	10	13	10	13	ns period
	t _{pdmin}	WAIT READY Delay Time from falling edge of ϕ , Data Bit Ready Mode	5	9	5	9	ns period
	t _{pdmax}	WAIT READY Delay Time from rising edge of ϕ , WAIT READY Wait Mode		120	120	ns	

T_A = 0°C to 70°C, V_{CC} = -5V, ±5%

Symbol	Parameter	Min	Max	Unit	Test Condition
V _{CC}	Clock Input Low Voltage	-0.3	-0.45	V	
V _{CC}	Clock Input High Voltage	V _{CC} - 0.6	-5.5	V	
V _L	Input Low Voltage	-0.3	-0.8	V	
V _H	Input High Voltage	+2.0	-5.5	V	
V _{OL}	Output Low Voltage		+0.4	V	I _{OL} = 20 mA
V _{OH}	Output High Voltage	+2.4		V	I _{OH} = -250 μ A
I _I	Input Leakage Current	-10	+10	μ A	V _I = V _{CC}
I _{I2}	3-State Output/Data Bus Input Leakage Current	-10	+10	μ A	V _I = V _{CC}
I _{syn}	SYNC Pin Leakage Current	-40	+10	μ A	
I _{CC}	Power Supply Current		100	mA	

T_A = 25°C, f = 1 MHz

Symbol	Parameter	Min	Max	Unit	Test Condition
C	Clock Capacitance		40	pF	
C _{in}	Input Capacitance		5	pF	Unmeasured pins returned to ground
C _{out}	Output Capacitance		10	pF	

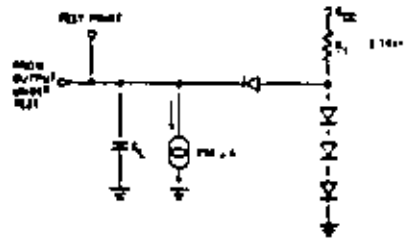

C_L = 50 pF. Increase delay by 10 ns for each 50 pF increase in C_L up to 200 pF maximum.



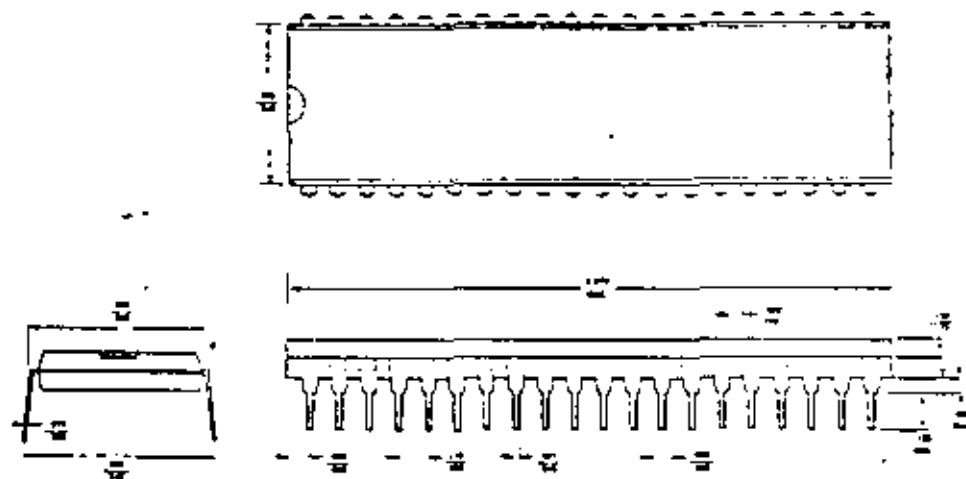
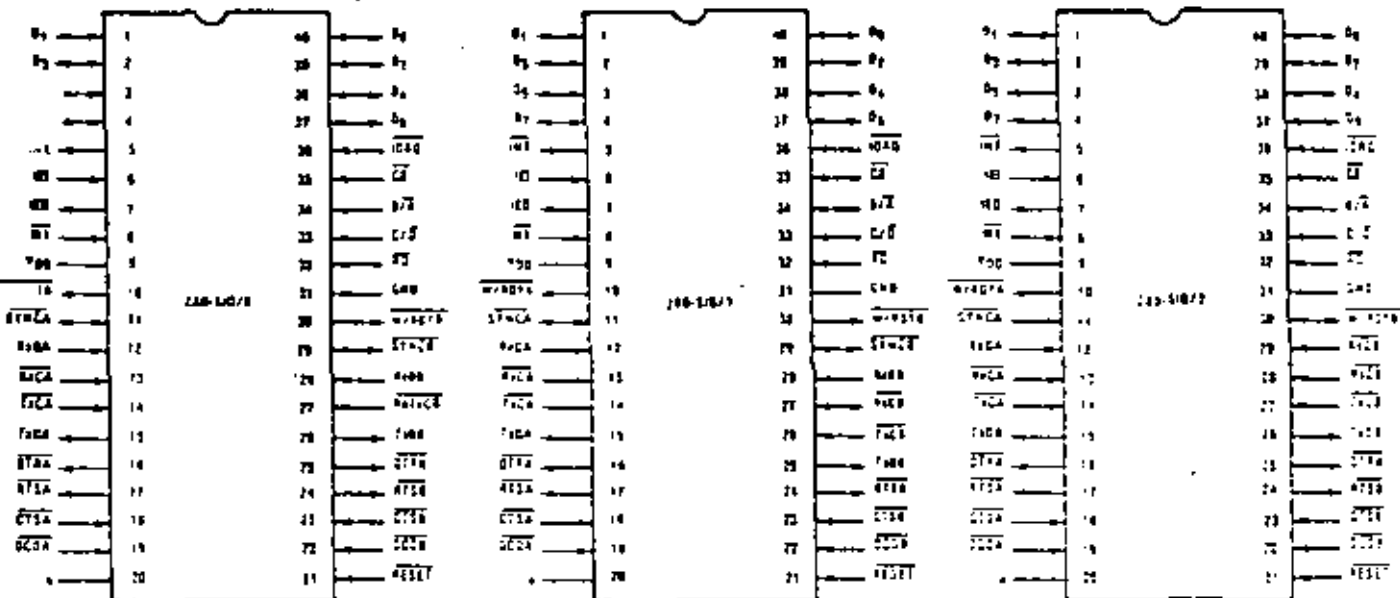

40-Pin Plastic

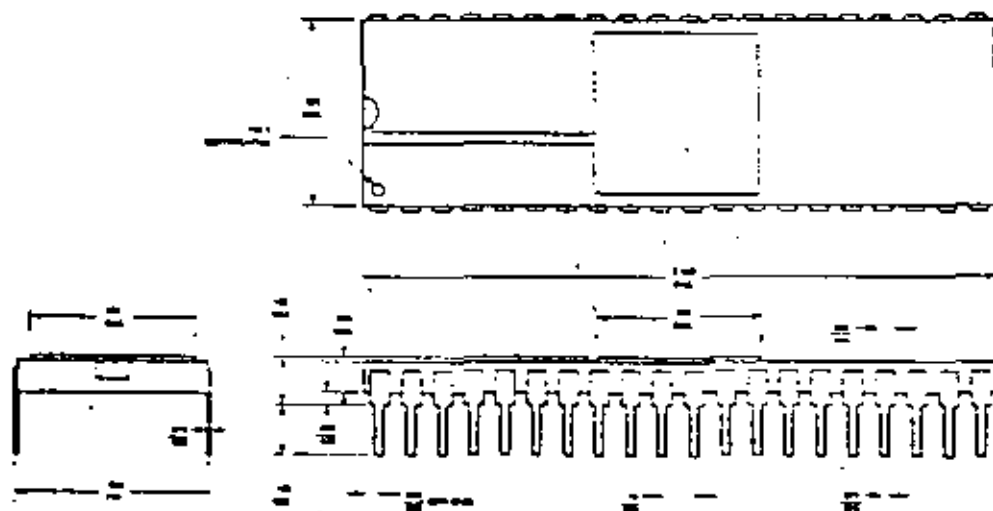

40-Pin Ceramic



/0 — Type 0 Bonding
 /1 — Type 1 Bonding
 /2 — Type 2 Bonding

C — Ceramic Package
 P — Plastic Package

S — Standard Range (5V, $\pm 5\%$, 0°C to 70°C)
 E — Extended Range (5V, $\pm 5\%$, -40°C to 85°C)
 M — Military Range (5V, $\pm 10\%$, -55°C to 125°C)

Examples:

Z80-SIO/1 CS (Type 1 bonding, ceramic package, standard range)

Z80-SIO/2 PS (Type 0 bonding, plastic package, standard range)

EAST

Sales & Tech. Center
 Zilog, Inc.
 76 Treble Cove Road
 N. Billerica, MA 01862
 TEL 617-667-2179
 TWX 710 347-6664

MIDATLANTIC

Tech. Center
 Zilog, Inc.
 P.O. Box 92
 Bergenfield, NJ 07621
 TEL 201 383 9134
 TWX 710 941 9771

MIDWEST

Sales and Tech. Center
 Zilog, Inc.
 430 E. Higgins
 Suite 114
 Schaumburg, IL 60195
 TEL 312 343 8090
 TWX 910 291 1064

NORTH CENTRAL

Sales and Tech. Center
 Zilog, Inc.
 1101 Bethel Road
 Columbus, Ohio 43220
 TEL 614 457 0820
 TWX 810 482 1707

SOUTHWEST REGION

Sales and Tech. Center
 Zilog, Inc.
 19001 San Park Blvd.
 Suite A
 Irvine, CA 92714
 TEL 714 249 2191
 TWX 910 293 2903

NORTHWEST

Sales & Tech. Center
 Zilog, Inc.
 10130 Bubb Road
 Cupertino, CA 95014
 TEL 408 446 4966 x261
 TWX 910 338 7621

WEST GERMANY

Zilog GmbH
 Zugspitzenstr. 6
 D-40114 Mülheim
 West Germany
 TEL 3105 4335
 TELEX 329110 Zilog G

JAPAN

Zilog, Inc. Japan
 Kyoshin Bldg.
 13-14 Sakuragaya 2-ch, N.
 Shinjyuku-ku Tokyo 150
 Japan
 TEL 03-476-3030

UNITED KINGDOM

Zilog (U.K.) Limited
 Northwin House
 Maidenhead SL6 6LL
 Berkshire England RG4 2DP
 TEL 06284 19131
 TELEX 440000

Z80[®]-CPU

30A-CPU

Product Specification

MARCH 1978

The Zilog Z80 product line is a complete set of micro-computer components, development systems and support software. The Z80 microcomputer component set includes all of the circuits necessary to build high-performance microcomputer systems with virtually no other logic and a minimum number of low cost standard memory elements.

The Z80 and Z80A CPU's are third generation single chip microprocessors with unrivaled computational power. This increased computational power results in higher system through-put and more efficient memory utilization when compared to second generation microprocessors. In addition, the Z80 and Z80A CPU's are very easy to implement into a system because of their single voltage requirement plus all output signals are fully decoded and timed to control standard memory or peripheral circuits. The circuit is implemented using an N-channel, ion implanted, silicon gate MOS process.

Figure 1 is a block diagram of the CPU. Figure 2 details internal register configuration which contains 208 bits read/write memory that are accessible to the programmer. The registers include two sets of six general purpose registers that may be used individually as 8-bit registers or as 16-bit register pairs. There are also two sets of accumulator and flag registers. The programmer has access to either set of main or alternate registers through a group of exchange instructions. This alternate set allows foreground/background mode of operation or may be reserved for very fast interrupt response. Each CPU also contains a 16-bit stack pointer which permits simple implementation of

multiple level interrupts, unlimited subroutine nesting and simplification of many types of data handling.

The two 16-bit index registers allow tabular data manipulation and easy implementation of relocatable code. The Refresh register provides for automatic, totally transparent refresh of external dynamic memories. The I register is used in a powerful interrupt response mode to form the upper 8 bits of a pointer to an interrupt service address table, while the interrupting device supplies the lower 8 bits of the pointer. An indirect call is then made to this service address.

FEATURES

- Single chip, N-channel Silicon Gate CPU.
- 158 instructions—includes all 78 of the 8080A instructions with total software compatibility. New instructions include 4-, 8- and 16-bit operations with more useful addressing modes such as indexed, out and relative.
- 17 internal registers.
- Three modes of fast interrupt response plus 1 non-maskable interrupt.
- Directly interfaces standard speed static or dynamic memories with virtually no external logic.
- 1.0 μ s instruction execution speed.
- Single 5 VDC supply and single-phase 5 volt Clock.
- Out-performs any other single chip microcomputer in 4-, 8-, or 16-bit applications.
- All pins TTL Compatible
- Built-in dynamic RAM refresh circuitry.

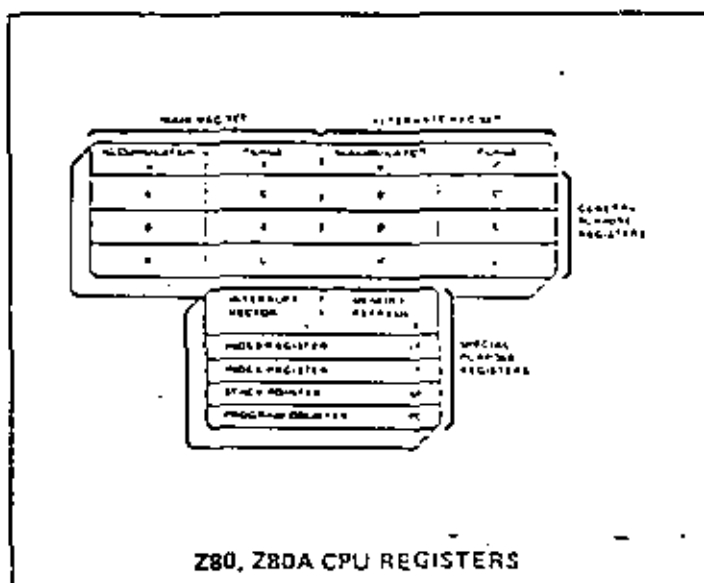
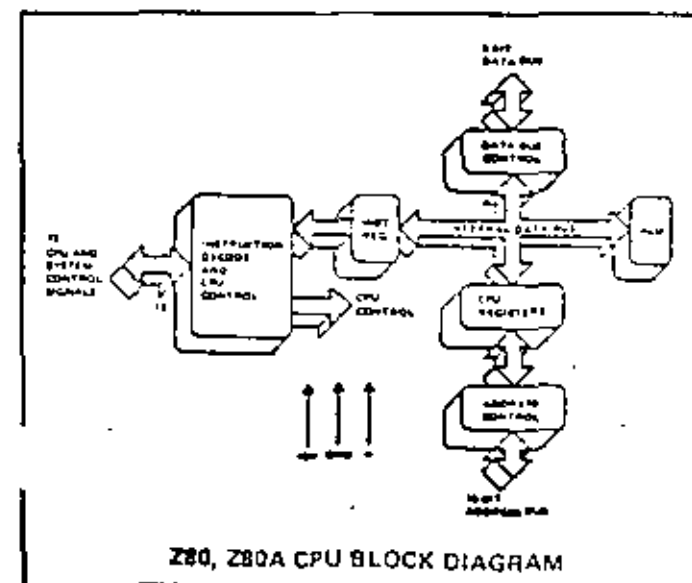



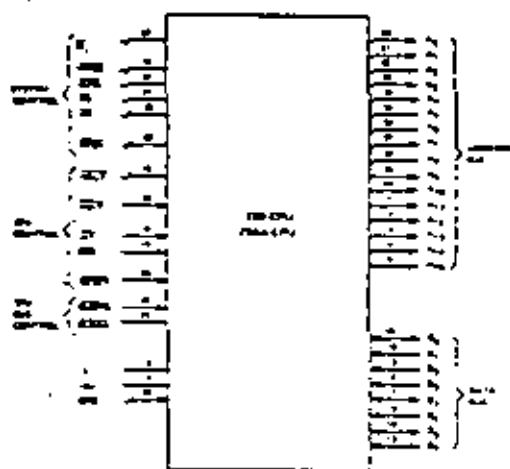

Z80, Z80A CPU PIN CONFIGURATION

A₀-A₁₅
(Address Bus) Tri-state output, active high. A₀-A₁₅ constitute a 16-bit address bus. The address bus provides the address for memory (up to 64K bytes) data exchanges and for I/O device data exchanges.

D₀-D₇
(Data Bus) Tri-state input/output, active high. D₀-D₇ constitute an 8-bit bidirectional data bus. The data bus is used for data exchanges with memory and I/O devices.

M₁
(Machine Cycle one) Output, active low. $\overline{M_1}$ indicates that the current machine cycle is the OP code fetch cycle of an instruction execution.

\overline{MREQ}
(Memory Request) Tri-state output, active low. The memory request signal indicates that the address bus holds a valid address for a memory read or memory write operation.

\overline{IORQ}
(Input/Output Request) Tri-state output, active low. The \overline{IORQ} signal indicates that the lower half of the address bus holds a valid I/O address for a I/O read or write operation. An \overline{IORQ} signal is also generated when an interrupt is being acknowledged to indicate that an interrupt response vector can be placed on the data bus.

\overline{RD}
(Memory Read) Tri-state output, active low. \overline{RD} indicates that the CPU wants to read data from memory or an I/O device. The addressed I/O device or memory should use this signal to gate data onto the CPU data bus.

\overline{WR}
(Memory Write) Tri-state output, active low. \overline{WR} indicates that the CPU data bus holds valid data to be stored in the addressed memory or I/O device.

\overline{RFSH}
(Refresh) Output, active low. \overline{RFSH} indicates that the lower 7 bits of the address bus contain a refresh address for dynamic memories and the current \overline{MREQ} signal should be used to do a refresh read to all dynamic memories.

\overline{HALT}
(Halt state) Output, active low. \overline{HALT} indicates that the CPU has executed a HALT software instruction and is awaiting either a non-maskable or a maskable interrupt (with the mask enabled) before operation can resume. While halted, the CPU executes NOP's to maintain memory refresh activity.

\overline{WAIT}
(Wait) Input, active low. \overline{WAIT} indicates to the Z-80 CPU that the addressed memory or I/O devices are not ready for a data transfer. The CPU continues to enter wait states for as long as this signal is active.

\overline{INT}
(Interrupt Request) Input, active low. The Interrupt Request signal is generated by I/O devices. A request will be honored at the end of the current instruction if the internal software controlled interrupt enable flip-flop (IFF) is enabled.

\overline{NMI}
(Non Maskable Interrupt) Input, active low. The non-maskable interrupt request line has a higher priority than \overline{INT} and is always recognized at the end of the current instruction, independent of the status of the interrupt enable flip-flop. \overline{NMI} automatically forces the Z-80 CPU to restart to location 0000H.

\overline{RESET} Input, active low. \overline{RESET} initializes the CPU as follows: reset interrupt enable flip-flop, clear PC and registers I and R and set interrupt to 8080A mode. During reset time, the address and data bus go to a high impedance state and all control output signals go to the inactive state.

\overline{BUSRQ}
(Bus Request) Input, active low. The bus request signal has a higher priority than \overline{NMI} and is always recognized at the end of the current machine cycle and is used to request the CPU address bus, data bus and tri-state output control signals to go to a high impedance state so that other devices can control these busses.

\overline{BUSAK}
(Bus Acknowledge) Output, active low. Bus acknowledge is used to indicate to the requesting device that the CPU address bus, data bus and tri-state control bus signals have been set to their high impedance state and the external device can now control these signals.

INSTRUCTION OP CODE FETCH

The program counter content (PC) is placed on the address bus immediately at the start of the cycle. One half clock time later MREQ goes active. The falling edge of MREQ can be used directly as a chip enable to dynamic memories. RD when active indicates that the memory data should be enabled onto the CPU data bus. The CPU samples data with the rising edge of the clock state T₃. Clock states T₁ and T₄ of a fetch cycle are used to refresh dynamic memories while the CPU is internally decoding and executing the instruction. The refresh control signal RFSH indicates that a refresh read of all dynamic memories should be accomplished.

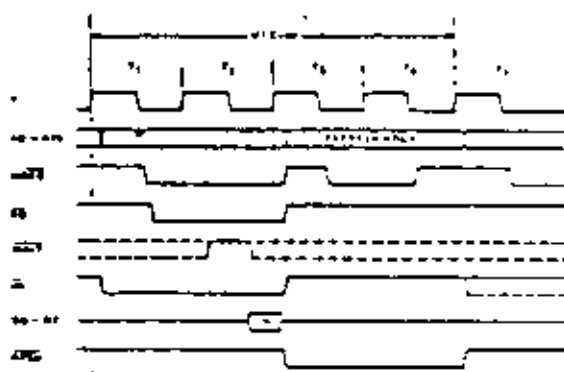

MEMORY READ OR WRITE CYCLES

Illustrated here is the timing of memory read or write cycles other than an OP code fetch (M₁ cycle). The MREQ and RD signals are used exactly as in the fetch cycle. In the case of a memory write cycle, the MREQ also becomes active when the address bus is stable so that it can be used directly as a chip enable for dynamic memories. The WR line is active when data on the data bus is stable so that it can be used directly as a R/W pulse to virtually any type of semiconductor memory.

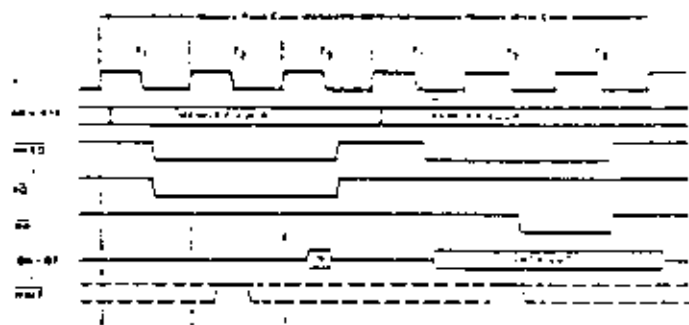

INPUT OR OUTPUT CYCLES

Illustrated here is the timing for an I/O read or I/O write operation. Notice that dummy I/O operations a single wait state is automatically inserted (T_w*). The reason for this is that during I/O operations this extra state allows sufficient time for an I/O port to decode its address and activate the WAIT line if a wait is required.

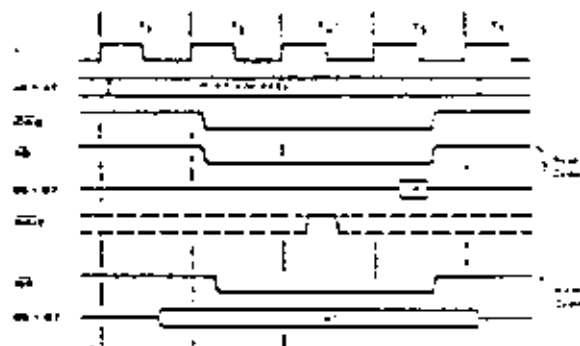

INTERRUPT REQUEST/ACKNOWLEDGE CYCLE

The interrupt signal is sampled by the CPU with the rising edge of the last clock at the end of any instruction. When an interrupt is accepted, a special M₁ cycle is generated. During this M₁ cycle, the IORQ signal becomes active (instead of MREQ) to indicate that the interrupting device can place an 8-bit vector on the data bus. Two wait states (T_w*) are automatically added to this cycle so that a ripple priority interrupt scheme, such as the one used in the Z80 peripheral controllers, can be easily implemented.

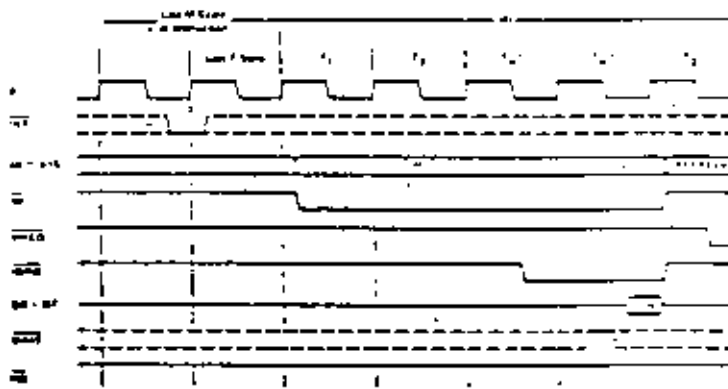

Z80, Z80A Instruction Set

The following is a summary of the Z80, Z80A instruction set showing the assembly language mnemonic and the symbolic operation performed by the instruction. A more detailed listing appears in the Z80-CPU technical manual, and assembly language programming manual. The instructions are divided into the following categories:

- | | |
|---|-------------------------|
| 8-bit loads | Miscellaneous Group |
| 16-bit loads | Rotates and Shifts |
| Exchanges | Bit Set, Reset and Test |
| Memory Block Moves | Input and Output |
| Memory Block Searches | Jumps |
| 8-bit arithmetic and logic | Calls |
| 16-bit arithmetic | Returns |
| General purpose Accumulator & Flag Operations | |

In the table the following terminology is used.

- b = a bit number in any 8-bit register or memory location
- cc = flag condition code
 - NZ = non zero
 - Z = zero
 - NC = non carry
 - C = carry
 - PO = Parity odd or no over flow
 - PE = Parity even or over flow
 - P = Positive
 - M = Negative (minus)

- d = any 8-bit destination register or memory location
 - dd = any 16-bit destination register or memory location
 - e = 8-bit signed 2's complement displacement used in relative jumps and indexed addressing
 - L = 8 special call locations in page zero. In decimal notation these are 0, 8, 16, 24, 32, 40, 48 and 56
 - n = any 8-bit binary number
 - nn = any 16-bit binary number
 - r = any 8-bit general purpose register (A, B, C, D, E, H, or L)
 - s = any 8-bit source register or memory location
 - sb = a bit in a specific 8-bit register or memory location
 - ss = any 16-bit source register or memory location
 - subscript "L" = the low order 8 bits of a 16-bit register
 - subscript "H" = the high order 8 bits of a 16-bit register
 - () = the contents within the () are to be used as a pointer to a memory location or I/O port number
- 8-bit registers are A, B, C, D, E, H, L, I and R.
 16-bit register pairs are AF, BC, DE and HL.
 16-bit registers are SP, PC, IX and IY.

Addressing Modes implemented include combinations of the following:

Immediate	Indexed
Immediate extended	Register
Modified Page Zero	Indexed
Relative	Register indirect
Extended	Bit

Mnemonic	Symbolic Operation	Comments
LD r, s	r ← s	s = r, n, (HL), (IX+e), (IY+e)
LD d, r	d ← r	d = (HL), r, (IX+e), (IY+e)
LD d, n	d ← n	d = (HL), (IX+e), (IY+e)
LD A, s	A ← s	s = (BC), (DE), (nn), I, R
LD d, A	d ← A	d = (BC), (DE), (nn), I, R
LD dd, nn	dd ← nn	dd = BC, DE, HL, SP, IX, IY
LD dd, (nn)	dd ← (nn)	dd = BC, DE, HL, SP, IX, IY
LD (nn), ss	(nn) ← ss	ss = BC, DE, HL, SP, IX, IY
LD SP, ss	SP ← ss	ss = HL, IX, IY
PUSH ss	(SP-1) ← ss _H ; (SP-2) ← ss _L	ss = BC, DE, HL, AF, IX, IY
POP dd	dd _L ← (SP); dd _H ← (SP+1)	dd = BC, DE, HL, AF, IX, IY
EX DE, HL	DE ↔ HL	
EX AF, AF'	AF ↔ AF'	
EX (BC), (DE)	(BC) ↔ (DE)	
EX (DE), (HL)	(DE) ↔ (HL)	
EX (SP), ss	(SP) ← ss _L ; (SP+1) ← ss _H	ss = HL, IX, IY

Mnemonic	Symbolic Operation	Comments
LDI	(DE) ← (HL); DE ← DE-1; HL ← HL+1; BC ← BC-1	
LDIR	(DE) ← (HL); DE ← DE+1; HL ← HL+1; BC ← BC-1; Repeat until BC = 0	
LDD	(DE) ← (HL); DE ← DE-1; HL ← HL-1; BC ← BC-1	
LDDR	(DE) ← (HL); DE ← DE+1; HL ← HL-1; BC ← BC-1; Repeat until BC = 0	
CPI	A ← HL; HL ← HL-1; BC ← BC-1	
CPIR	A ← HL; HL ← HL-1; BC ← BC-1; Repeat until BC = 0 or A = (HL)	A ← HL sets the flags only. A is not affected.
CPD	A ← HL; HL ← HL-1; BC ← BC-1	
CPDR	A ← HL; HL ← HL-1; BC ← BC-1; Repeat until BC = 0 or A = (HL)	
ADD s	A ← A + s	CY is the carry flag
ADC s	A ← A + s + CY	
SUB s	A ← A - s	
SBC s	A ← A - s - CY	
AND s	A ← A & s	
OR s	A ← A s	
XOR s	A ← A ⊕ s	

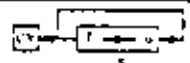
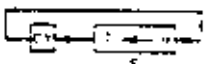
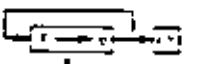
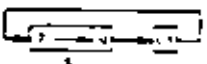
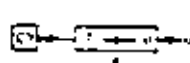
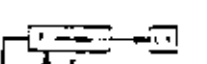
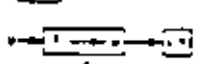
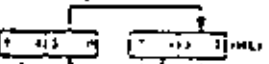
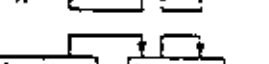

ALU
 16 BIT ARITHMETIC
 CPU ACC. & FLAG
 MISCELLANEOUS
 ROTATES AND SHIFTS

Mnemonic	Symbolic Operation	Comments
CP s	A - s	s = r, n (HL) (IX+e), (IY+e)
INC d	d - d + 1	d = r, (HL) (IX+e), (IY+e)
DEC d	d - d - 1	
ADD HL, ss	HL - HL + ss	ss = BC, DE, HL, SP
ADC HL, ss	HL - HL + ss + CY	
SBC HL, ss	HL - HL - ss - CY	
ADD IX, ss	IX - IX + ss	
ADD IY, ss	IY - IY + ss	ss = BC, DE, IY, SP
INC dd	dd - dd + 1	dd = BC, DE, HL, SP, IX, IY
DEC dd	dd - dd - 1	dd = BC, DE, HL, SP, IX, IY
DAA	Converts A contents into packed BCD following add or subtract.	Operands must be in packed BCD format
CPL	A - A	
NEG	A - 00 - A	
CCF	CY - CY	
SCF	CY = 1	
NOP	No operation	
HLT	Halt CPU	
DI	Disable Interrupts	
EI	Enable Interrupts	
IM 0	Set interrupt mode 0	5080A mode
IM 1	Set interrupt mode 1	Call to 0055H
IM 2	Set interrupt mode 2	Indirect Call
RLC s		s = r, (HL) (IX+e), (IY+e)
RL s		
RRC s		
RR s		
SLA s		
SRA s		
SRL s		
RLD		
RRD		

BIT S, R, A
 INPUT AND OUTPUT
 JUMPS
 CALLS
 RESTARTS
 RETURNS

Mnemonic	Symbolic Operation	Comments
BIT b, s	Z - \overline{b}	Z is zero flag
SET b, s	b = 1	s = r, (HL)
RES b, s	b = 0	(IX+e), (IY+e)
IN A, (n)	A = (n)	Set flags
IN r, (C)	r = (C)	
INI	(HL) - (C), HL - HL + 1 B - B - 1	
INIR	(HL) - (C), HL - HL + 1 B - B - 1 Repeat until B = 0	
IND	(HL) - (C), HL - HL - 1 B - B - 1	
INDR	(HL) - (C), HL - HL - 1 B - B - 1 Repeat until B = 0	
OUT(n), A	(n) = A	
OUT(C), r	(C) = r	
OUTI	(C) - (HL), HL - HL - 1 B - B - 1	
OTIR	(C) - (HL), HL - HL - 1 B - B - 1 Repeat until B = 0	
OUTD	(C) - (HL), HL - HL - 1 B - B - 1	
OTDR	(C) - (HL), HL - HL - 1 B - B - 1 Repeat until B = 0	
JP nn	PC = nn	cc { NZ PD Z PE NC P C M
JP cc, nn	If condition cc is true PC = nn, else continue	
JR e	PC = PC + e	cc { NZ PD Z PE C M
JR kk, e	If condition kk is true PC = PC + e, else continue	
JP (ss)	PC = ss	ss = HL, IX, IY
DJNZ e	B - B - 1, if B = 0 continue, else PC = PC + e	
CALL nn	(SP-1) = PC _H (SP-2) = PC _L , PC = nn	cc { NZ PD Z PE NC P C M
CALL cc, nn	If condition cc is false continue, else same as CALL nn	
RST L	(SP-1) = PC _H (SP-2) = PC _L , PC _H = 0 PC _L = L	
RET	PC _L = (SP) PC _H = (SP+1)	cc { NZ PD Z PE NC P C M
RET cc	If condition cc is false continue, else same as RET	
RETI	Return from interrupt, same as RET	
RETN	Return from non- maskable interrupt	



T_A = 0°C to 70°C, V_{CC} = +5V ± 5%. Unless Otherwise Noted.

Symbol	Signals	Parameter	Min	Max	Unit	Test Conditions
•	t _{CL} (PΦ)	Clock Period	4	11.25	μsec	
	t _{CL} (PH)	Clock Pulse Width (Clock High)	180	250	nsec	
	t _{CL} (PL)	Clock Pulse Width (Clock Low)	180	250	nsec	
	t _{CL}	Clock Rise and Fall Time		20	nsec	
A ₁₅	t _{OL} (AD)	Address Output Delay		125	nsec	C _L = 100pF
	t _{PL} (AD)	Device Output Delay		120	nsec	
	t _{OL}	Address Strobe Pulse to \overline{MEM} (Address Output)		120	nsec	
	t _{OL}	Address Strobe Pulse to \overline{MEM} (Address Output)		120	nsec	
	t _{OL}	Address Strobe Pulse to \overline{MEM} (Address Output)		120	nsec	
D ₇₋₁₅	t _{OD} (D)	Data Output Delay		130	nsec	C _L = 100pF
	t _{FD} (D)	Delay to Rising Edge of Clock		70	nsec	
	t _{SD} (D)	Data Setup Time to Rising Edge of Clock During M1 Cycle		70	nsec	
	t _{HD} (D)	Data Hold Time to Falling Edge of Clock During M1 Cycle		70	nsec	
	t _{OL} (D)	Data Output Pulse to \overline{MEM} (Address Output)		120	nsec	
	t _{OL}	Data Output Pulse to \overline{MEM} (Address Output)		120	nsec	
	t _{OL}	Data Output Pulse to \overline{MEM} (Address Output)		120	nsec	
M	t _M	Any Hold Time for Setup Time	3		nsec	
	W _{REQ}	t _{OL} (W _{REQ})	\overline{WREQ} Delay From Rising Edge of Clock, \overline{WREQ} Low		170	nsec
t _{PH} (W _{REQ})		\overline{WREQ} Delay From Falling Edge of Clock, \overline{WREQ} High		170	nsec	
t _{OL} (W _{REQ})		\overline{WREQ} Delay From Rising Edge of Clock, \overline{WREQ} High		170	nsec	
t _{PH} (W _{REQ})		\overline{WREQ} Delay From Falling Edge of Clock, \overline{WREQ} Low		170	nsec	
t _{PH} (W _{REQ})		\overline{WREQ} Delay From Falling Edge of Clock, \overline{WREQ} High		170	nsec	
Z _{REQ}	t _{OL} (Z _{REQ})	\overline{ZREQ} Delay From Rising Edge of Clock, \overline{ZREQ} Low		90	nsec	C _L = 100pF
	t _{PH} (Z _{REQ})	\overline{ZREQ} Delay From Falling Edge of Clock, \overline{ZREQ} Low		90	nsec	
	t _{OL} (Z _{REQ})	\overline{ZREQ} Delay From Rising Edge of Clock, \overline{ZREQ} High		90	nsec	
	t _{PH} (Z _{REQ})	\overline{ZREQ} Delay From Falling Edge of Clock, \overline{ZREQ} High		90	nsec	
RD	t _{OL} (RD)	\overline{RD} Delay From Rising Edge of Clock, \overline{RD} Low		100	nsec	C _L = 100pF
	t _{PH} (RD)	\overline{RD} Delay From Falling Edge of Clock, \overline{RD} Low		100	nsec	
	t _{OL} (RD)	\overline{RD} Delay From Rising Edge of Clock, \overline{RD} High		100	nsec	
	t _{PH} (RD)	\overline{RD} Delay From Falling Edge of Clock, \overline{RD} High		100	nsec	
	t _{PH} (RD)	\overline{RD} Delay From Falling Edge of Clock, \overline{RD} High		100	nsec	
WR	t _{OL} (WR)	\overline{WR} Delay From Rising Edge of Clock, \overline{WR} Low		90	nsec	C _L = 100pF
	t _{PH} (WR)	\overline{WR} Delay From Falling Edge of Clock, \overline{WR} Low		90	nsec	
	t _{OL} (WR)	\overline{WR} Delay From Rising Edge of Clock, \overline{WR} High		90	nsec	
	t _{PH} (WR)	\overline{WR} Delay From Falling Edge of Clock, \overline{WR} High		90	nsec	
	t _{PH} (WR)	\overline{WR} Delay From Falling Edge of Clock, \overline{WR} High		90	nsec	
MT	t _{OL} (MT)	\overline{MT} Delay From Rising Edge of Clock, \overline{MT} Low		110	nsec	C _L = 100pF
	t _{PH} (MT)	\overline{MT} Delay From Rising Edge of Clock, \overline{MT} High		110	nsec	
RFSH	t _{OL} (RFSH)	\overline{RFSH} Delay From Rising Edge of Clock, \overline{RFSH} Low		170	nsec	C _L = 50pF
	t _{PH} (RFSH)	\overline{RFSH} Delay From Rising Edge of Clock, \overline{RFSH} High		170	nsec	
WAIT	t _{WAIT}	\overline{WAIT} Setup Time to Rising Edge of Clock	70		nsec	
HALT	t _{HALT}	\overline{HALT} Delay Time From Rising Edge of Clock		200	nsec	C _L = 100pF
INT	t _{INT}	\overline{INT} Setup Time to Rising Edge of Clock	50		nsec	
INT	t _{INT}	Pin-to-Driver, \overline{INT} Low	60		nsec	
BUSRD	t _{BUSRD}	\overline{BUSRQ} Setup Time to Rising Edge of Clock	40		nsec	
BUSER	t _{OL} (BUSER)	\overline{BUSER} Delay From Rising Edge of Clock, \overline{BUSER} Low		110	nsec	C _L = 50pF
	t _{PH} (BUSER)	\overline{BUSER} Delay From Rising Edge of Clock, \overline{BUSER} High		110	nsec	
RESET	t _{RESET}	\overline{RESET} Setup Time to Rising Edge of Clock	40		nsec	
TRIC	t _{TRIC}	Delay to Rising Edge of Clock, \overline{TRIC} Low to High		100	nsec	
t _{INT}	t _{INT}	\overline{INT} Strobe Pulse to \overline{IRQ} (Interrupt Ack)	1115		nsec	

(1) $t_{OL}(\overline{MEM}) = t_{OL}(\overline{MEM}) + t_{OL}(\overline{MEM})$

(2) $t_{OL}(\overline{MEM}) = t_{OL}(\overline{MEM}) + t_{OL}(\overline{MEM})$

(3) $t_{OL}(\overline{MEM}) = t_{OL}(\overline{MEM})$

(4) $t_{OL}(\overline{MEM}) = t_{OL}(\overline{MEM}) + t_{OL}(\overline{MEM})$

(5) $t_{OL}(\overline{MEM}) = t_{OL}(\overline{MEM}) + t_{OL}(\overline{MEM})$

(6) $t_{OL}(\overline{MEM}) = t_{OL}(\overline{MEM}) + t_{OL}(\overline{MEM})$

(7) $t_{OL}(\overline{MEM}) = t_{OL}(\overline{MEM}) + t_{OL}(\overline{MEM})$

(8) $t_{OL}(\overline{MEM}) = t_{OL}(\overline{MEM}) + t_{OL}(\overline{MEM})$

(9) $t_{OL}(\overline{MEM}) = t_{OL}(\overline{MEM}) + t_{OL}(\overline{MEM})$

(10) $t_{OL}(\overline{MEM}) = t_{OL}(\overline{MEM}) + t_{OL}(\overline{MEM})$

(11) $t_{OL}(\overline{MEM}) = t_{OL}(\overline{MEM}) + t_{OL}(\overline{MEM})$

(12) $t_{OL}(\overline{MEM}) = t_{OL}(\overline{MEM}) + t_{OL}(\overline{MEM})$

(13) $t_{OL}(\overline{MEM}) = t_{OL}(\overline{MEM}) + t_{OL}(\overline{MEM})$

(14) $t_{OL}(\overline{MEM}) = t_{OL}(\overline{MEM}) + t_{OL}(\overline{MEM})$

(15) $t_{OL}(\overline{MEM}) = t_{OL}(\overline{MEM}) + t_{OL}(\overline{MEM})$

(16) $t_{OL}(\overline{MEM}) = t_{OL}(\overline{MEM}) + t_{OL}(\overline{MEM})$

(17) $t_{OL}(\overline{MEM}) = t_{OL}(\overline{MEM}) + t_{OL}(\overline{MEM})$

(18) $t_{OL}(\overline{MEM}) = t_{OL}(\overline{MEM}) + t_{OL}(\overline{MEM})$

(19) $t_{OL}(\overline{MEM}) = t_{OL}(\overline{MEM}) + t_{OL}(\overline{MEM})$

(20) $t_{OL}(\overline{MEM}) = t_{OL}(\overline{MEM}) + t_{OL}(\overline{MEM})$

NOTES

- A. Data should be enabled onto the CPU data bus when \overline{RD} is active. During interrupt acknowledge data should be enabled when \overline{MT} and \overline{TRIC} are high going.
- B. All control signals are tri-state bus drivers. Address may be useful in combination with output 1 to the clock.
- C. The \overline{RESET} signal must be active for a minimum of 1 clock cycle.
- D. Output Delay is Limited Capacitance
= 70°C, V_{CC} = +5V ± 5%
Add 10nsec delay for each 50pf increase in load up to a maximum of 200pf for the data bus & 100pf for address & control lines.
- E. Although not by design, testing guarantees 1 μsec of 200 psec maximum.

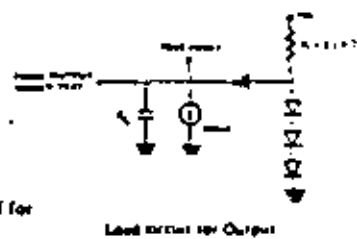

(21) $t_{OL}(\overline{MEM}) = t_{OL}(\overline{MEM}) + t_{OL}(\overline{MEM})$

Timing measurements are made at the following voltages, unless otherwise specified:

	7T	7F
CLOCK	V _{CC} - 6V	4TV
OUTPUT	20V	1V
INPUT	20V	1V
FLOAT	ΔV	10.5V

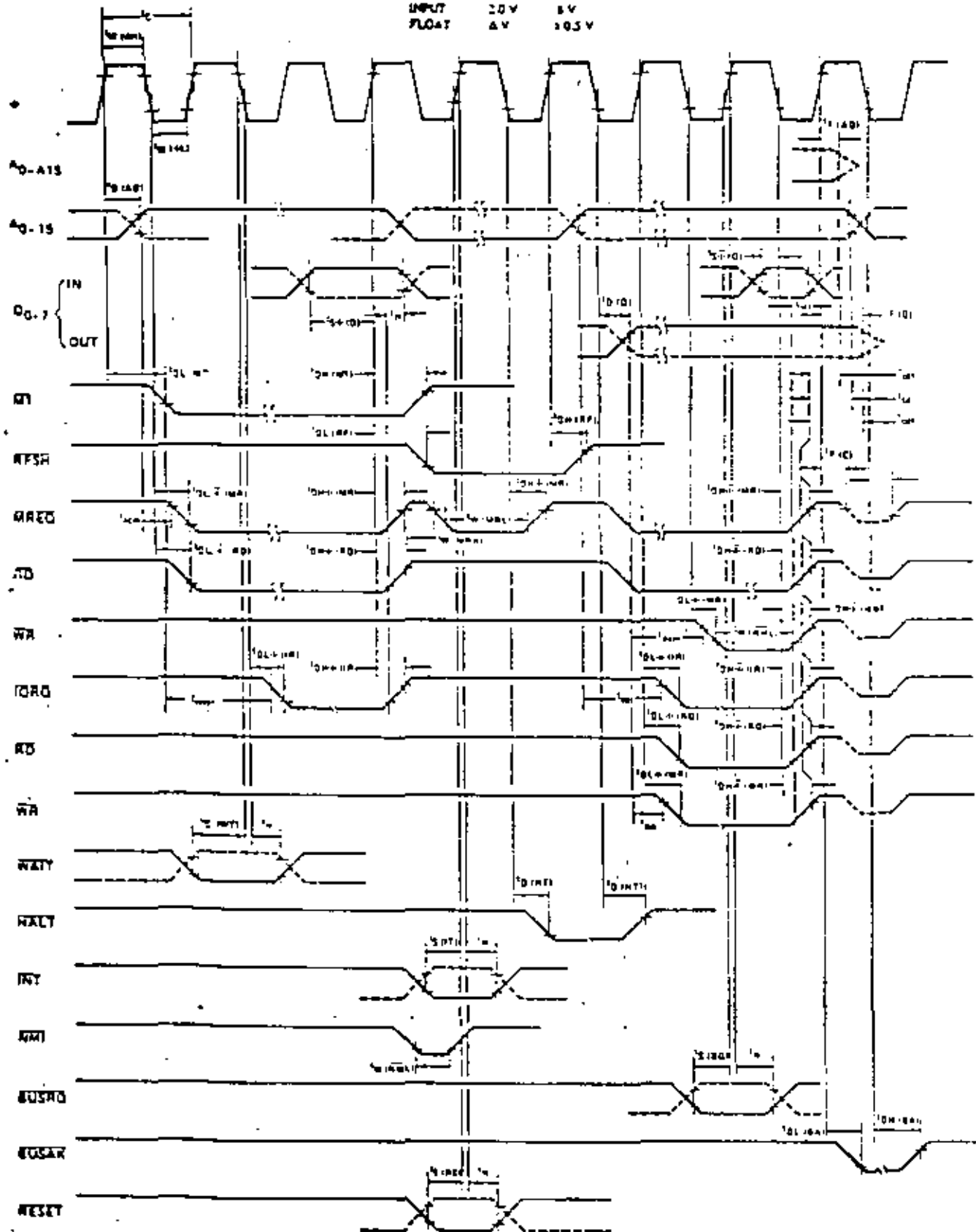

Absolute Maximum Ratings

Temperature Under Bias	Specified operating range
Storage Temperature	-40°C to +150°C
Voltage On Any Pin with Respect to Ground	-2.3V to +2V
Power Dissipation	1.5W

Comments

Stresses above those listed under "Absolute Maximum Rating" may cause permanent damage to the device. This is a stress rating only and functional operation of the device at these or any other conditions above those indicated in the operational sections of this specification is not implied. Exposure to absolute maximum rating conditions for extended periods may affect device reliability.

Z80-CPU D.C. Characteristics

$T_A = 0^\circ\text{C}$ to 70°C , $V_{CC} = 5\text{V} \pm 5\%$ unless otherwise specified

Symbol	Parameter	Min	Typ	Max	Unit	Test Condition
V_{ILC}	Clock Input Low Voltage	-0.3		0.45	V	
V_{IHC}	Clock Input High Voltage	$V_{CC} - 0.6$		$V_{CC} + 0.3$	V	
V_{IL}	Input Low Voltage	-0.3		0.8	V	
V_{IH}	Input High Voltage	2.0		V_{CC}	V	
V_{OL}	Output Low Voltage			0.4	V	$I_{OL} = 10\text{mA}$
V_{OH}	Output High Voltage	2.4			V	$I_{OH} = -250\mu\text{A}$
I_{CC}	Power Supply Current			150	mA	
I_{LI}	Input Leakage Current			10	μA	$V_{IN} = 1\text{ to }V_{CC}$
I_{LOH}	Tri State Output Leakage Current in Float			10	μA	$V_{OUT} = 2.4\text{ to }V_{CC}$
I_{LOL}	Tri State Output Leakage Current in Float			-10	μA	$V_{OUT} = 0.4\text{V}$
I_{LD}	Data Bus Leakage Current in Input Mode			± 10	μA	$0 < V_{IN} < V_{CC}$

Z80A-CPU D.C. Characteristics

$T_A = 0^\circ\text{C}$ to 70°C , $V_{CC} = 5\text{V} \pm 5\%$ unless otherwise specified

Symbol	Parameter	Min	Typ	Max	Unit	Test Condition
V_{ILC}	Clock Input Low Voltage	-0.3		0.45	V	
V_{IHC}	Clock Input High Voltage	$V_{CC} - 0.6$		$V_{CC} + 0.3$	V	
V_{IL}	Input Low Voltage	-0.3		0.8	V	
V_{IH}	Input High Voltage	2.0		V_{CC}	V	
V_{OH}	Output Low Voltage			0.4	V	$I_{OL} = 10\text{mA}$
V_{OH}	Output High Voltage	2.4			V	$I_{OH} = -250\mu\text{A}$
I_{CC}	Power Supply Current		40	200	mA	
I_{LI}	Input Leakage Current			10	μA	$V_{IN} = 1\text{ to }V_{CC}$
I_{LOH}	Tri State Output Leakage Current in Float			10	μA	$V_{OUT} = 2.4\text{ to }V_{CC}$
I_{LOL}	Tri State Output Leakage Current in Float			-10	μA	$V_{OUT} = 0.4\text{V}$
I_{LD}	Data Bus Leakage Current in Input Mode			± 10	μA	$0 < V_{IN} < V_{CC}$

Note: For Z80-CPU and Z80A-CPU, pins 1 and 16 are connected to ground for the military grade devices only.

$I_{CC} = 100\text{mA}$

Capacitance

$T_A = 25^\circ\text{C}$, $f = 1\text{ MHz}$

Unmeasured pins returned to ground

Symbol	Parameter	Max	Unit
C_p	Clock Capacitance	15	—
C_{IN}	Input Capacitance	5	—
C_{OUT}	Output Capacitance	5	—

Z80-CPU

Ordering Information

- C — Ceramic
- P — Plastic
- S — Standard 5V ±5% to 70°C
- E — Extended 5V ±5% to -40°C to +150°C
- M — Military 5V ±5% to -40°C to +125°C

Capacitance

$T_A = 25^\circ\text{C}$, $f = 1\text{ MHz}$

Unmeasured pins returned to ground

Symbol	Parameter	Max	Unit
C_p	Clock Capacitance	15	—
C_{IN}	Input Capacitance	5	—
C_{OUT}	Output Capacitance	5	—

Z80A-CPU

Ordering Information

- C — Ceramic
- P — Plastic
- S — Standard 5V ±5% to 70°C

T_A = 0°C to 70°C, V_{CC} = +5V ± 5%, Unless Otherwise Noted.

Signal	Symbol	Parameter	Min	Max	Unit	Test Conditions
φ	t _c (PH)	Clock Period	25	125	ns	
	t _c (HL)	Clock Pulse Width, Clock High	10	125	ns	
	t _c (LL)	Clock Pulse Width, Clock Low	10	125	ns	
	t _r	Clock Rise and Fall Time		0	ns	
A ₀₋₁₅	t _{0(A0)}	Address Output Delay		110	ns	C _L = 50pF
	t _{0(A15)}	Delay to Float		90	ns	
	t _{1(A0)}	Address Setup Time to \overline{MEMO} (Minimum +04)			ns	
	t _{1(A15)}	Address Setup Time to \overline{MEMO} (0 = \overline{MEMO} is 0 Output)			ns	
	t _{2(A0)}	Address Hold Time from \overline{MEMO} to \overline{MEMO} or \overline{MEMO}			ns	
	t _{2(A15)}	Address Hold Time from \overline{MEMO} or \overline{MEMO} to Float			ns	
D ₀₋₇	t _{0(D)}	Data Output Delay		150	ns	C _L = 50pF
	t _{0(D)}	Delay to Float During Write Cycle		90	ns	
	t _{1(D)}	Data Setup Time to Rising Edge of Clock During M1 Cycle	25		ns	
	t _{1(D)}	Data Setup Time to Falling Edge of Clock During M2 to M3	25		ns	
	t _{2(D)}	Data Setup Time to \overline{MEMO} (Minimum +04)	25		ns	
	t _{2(D)}	Data Setup Time to \overline{MEMO} (0 = \overline{MEMO} is 0 Output)	25		ns	
	t _{2(D)}	Data Setup Time from \overline{MEMO}	25		ns	
t _h	Any Hold Time for Setup Time		0	ns		
MEMO	t _{0(M)}	\overline{MEMO} Delay From Rising Edge of Clock, \overline{MEMO} Low		95	ns	C _L = 50pF
	t _{0(M)}	\overline{MEMO} Delay From Rising Edge of Clock, \overline{MEMO} High		95	ns	
	t _{1(M)}	\overline{MEMO} Delay From Falling Edge of Clock, \overline{MEMO} High		95	ns	
	t _{1(M)}	Pulse Width, \overline{MEMO} Low		95	ns	
	t _{1(M)}	Pulse Width, \overline{MEMO} High		95	ns	
MEMO	t _{0(M)}	\overline{MEMO} Delay From Rising Edge of Clock, \overline{MEMO} Low		95	ns	C _L = 50pF
	t _{0(M)}	\overline{MEMO} Delay From Rising Edge of Clock, \overline{MEMO} High		95	ns	
	t _{1(M)}	\overline{MEMO} Delay From Falling Edge of Clock, \overline{MEMO} High		95	ns	
	t _{1(M)}	Pulse Width, \overline{MEMO} Low		95	ns	
	t _{1(M)}	Pulse Width, \overline{MEMO} High		95	ns	
RD	t _{0(R)}	\overline{RD} Delay From Rising Edge of Clock, \overline{RD} Low		95	ns	C _L = 50pF
	t _{0(R)}	\overline{RD} Delay From Rising Edge of Clock, \overline{RD} High		95	ns	
	t _{1(R)}	\overline{RD} Delay From Falling Edge of Clock, \overline{RD} High		95	ns	
	t _{1(R)}	\overline{RD} Delay From Falling Edge of Clock, \overline{RD} Low		95	ns	
	t _{1(R)}	\overline{RD} Delay From Rising Edge of Clock, \overline{RD} High		95	ns	
WR	t _{0(W)}	\overline{WR} Delay From Rising Edge of Clock, \overline{WR} Low		95	ns	C _L = 50pF
	t _{0(W)}	\overline{WR} Delay From Falling Edge of Clock, \overline{WR} Low		95	ns	
	t _{1(W)}	\overline{WR} Delay From Rising Edge of Clock, \overline{WR} High		95	ns	
	t _{1(W)}	Pulse Width, \overline{WR} Low		95	ns	
	t _{1(W)}	Pulse Width, \overline{WR} High		95	ns	
MEMO	t _{0(M)}	\overline{MEMO} Delay From Rising Edge of Clock, \overline{MEMO} Low		100	ns	C _L = 50pF
	t _{0(M)}	\overline{MEMO} Delay From Rising Edge of Clock, \overline{MEMO} High		100	ns	
MEMO	t _{0(M)}	\overline{MEMO} Delay From Rising Edge of Clock, \overline{MEMO} Low		100	ns	C _L = 50pF
	t _{0(M)}	\overline{MEMO} Delay From Rising Edge of Clock, \overline{MEMO} High		100	ns	
RESET	t _{0(R)}	RESET Setup Time to Rising Edge of Clock	60		ns	
	t _{0(F)}	Delay to Float (MEMO, RD and WR)		90	ns	
	t _h	Any Setup Time Prior to MEMO (Minimum +04)		110	ns	

- (1) $t_{0(A0)} = t_{0(A15)} = t_{0(D)}$
- (2) $t_{0(A0)} = t_{0(A15)} = t_{0(D)}$
- (3) $t_{0(A0)} = t_{0(A15)} = t_{0(D)}$
- (4) $t_{0(M)} = t_{0(W)}$
- (5) $t_{0(M)} = t_{0(W)}$
- (6) $t_{0(M)} = t_{0(W)}$
- (7) $t_{0(M)} = t_{0(W)}$
- (8) $t_{0(M)} = t_{0(W)}$
- (9) $t_{0(M)} = t_{0(W)}$
- (10) $t_{0(M)} = t_{0(W)}$
- (11) $t_{0(M)} = t_{0(W)}$

NOTES

- A. Data should be established onto the CPU data bus when \overline{RD} is active. During interrupt acknowledge data should be maintained when \overline{MEMO} and \overline{MEMO} are both active.
- B. All control signals are internally synchronized, so they may be equally asynchronous with respect to the clock.
- C. The \overline{RESET} signal must be active for a minimum of 3 clock cycles.
- D. Output Delay vs. Loaded Capacitance
T_A = 70°C, V_{CC} = +5V ± 5%
Add 10ns delay for each 50pf increase in load up to maximum of 200pf for data bus and 100pf for address & control lines.
- E. Although stated by design, loading parameters (C_L max) of 200 pF maximum.

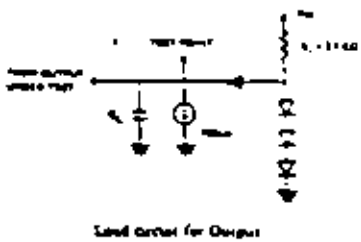

Package Configuration

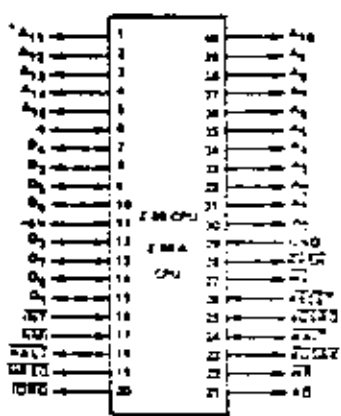

Package Outline

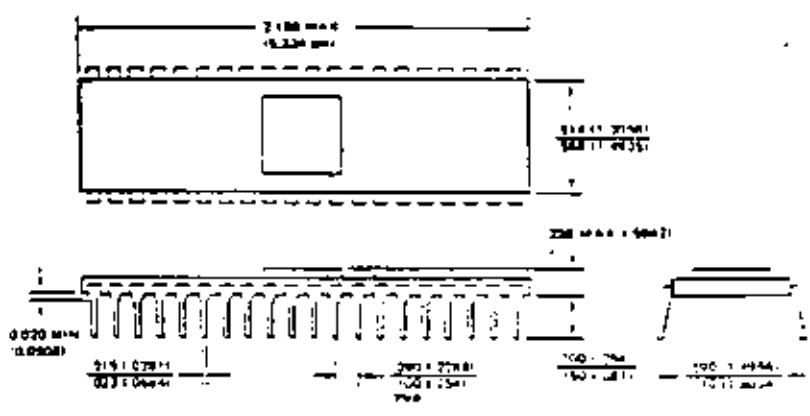

*Dimensions for metric system are in parentheses

EASTERN

- Hallmark Electronics
4739 Commercial Drive
Kennesaw, AL 35895
TEL 205 337 8700
TWX 810 326 2187
- Hallmark Electronics
1302 West McPhis Road
Fort Lauderdale, FL 33309
TEL 305 971 9230
TWX 510 936 9220
- Sk Electronics
Lake Ellenor Drive
Orlando, FL 32807
TEL 305 855 4020
TWX 610 450 0183
- Hallmark Electronics
3355 Amerscon Drive
Baltimore, MD 21227
TEL 301 796 9100
TWX 710 862 1942
- Hallmark Electronics
1208 Front Street
Building K
Raleigh, NC 27609
TEL 919 832 4463
TWX 510 928 1831
- Hallmark Electronics
Pike Industrial Park
Huntington Valley, PA 19006
TEL 215 355 2500
TWX 510 667 1750
- Sommat
916 Main Street
Buffalo, NY 14202
TEL 716 884 3450

Walsh Electronics
2554 State Street
Hamden, CT 06517
TEL 203 281 1166
TWX 400 922 1734

Walsh Electronics
1851 New Highway
Farmingdale, LI, NY 11735
TEL 516 293 2725
FAX 516 293 4707

Aurora Electronics
One Walsh Road
Burlington, MA 01803
TEL 617 272 5200
TWX 710 332 6159

Walsh Electronics
1111 Paulson Avenue
Clifton, NJ 07015
TEL 201 340 1900
TWX 710 989 7052

MIDWESTERN

Hallmark Electronics
140 Grossen Avenue
Elk Grove Village, IL 60076
TEL 312 437 8600
TWX 910 223 3645

Hallmark Electronics
11870 West 91st Street
Consolidation Industrial Park
Shawnee Mission, KS 66214
TEL 913 888 4747
TWX 910 749 6020

Hallmark Electronics
9201 Penn Avenue South
Suite 10
Bloomington, MN 55435
TEL 612 884 9056
TWX 910 376 3187

Hallmark Electronics
13789 Rider Trail
Earth City, MO 63045
TEL 314 291 5350
TWX 910 760 0671

Hallmark Electronics
4969 Worthington Glens Road
Worthington, OH 43085
TEL 614 346 1652

Hallmark Electronics
4846 S. 33rd E. Avenue
Tulsa, OK 74145
TEL 918 533 3458
TWX 910 843 2290

Hallmark Electronics
3100-A Industrial Terrace
Austin, TX 78758
TEL 512 837 2841
TWX 910 874 2031

Hallmark Electronics
9333 Forest Lane
Dallas, TX 75231
TEL 214 234 7700
TWX 910 467 4721

Hallmark Electronics
8000 Westport
Houston, TX 77063
TEL 713 781 6100
TWX 910 882 2711

Hallmark Electronics
237 South Curtis
West Allam, NJ 07014
TEL 414 476 1270
TWX 910 752 3186

RM Electronics
4840 South Division
Kentwood, MI 49509
TEL 616 331 9500
TWX 810 273 8779

RM Electronics
47 Chestnut Lane
Westmont, Illinois 60559
TEL 312 323 9070

MOUNTAIN

Century Electronics
121 Elizabeth, NE
Albuquerque, NM 87123
TEL 305 292 2750
TWX 910 989 0625

WESTERN

Intermark Electronics
1802 E. Corporate Avenue
Santa Ana, CA 92705
TEL 714 540 1522
TWX 910 395 1583

Intermark Electronics
4640 Sorrento Valley Blvd.
San Diego, CA 92121
TEL 714 279 2200
714 451 9005
TWX 910 355 1515

Intermark Electronics
1020 Stewart Drive
Sunnyvale, CA 94086
TEL 408 738 1111
TWX 910 339 9310

R.V. Weatherford Co
6921 San Fernando Road
Glendale, CA 91201
TEL 213 849 3451
TWX 910 498 2223

R.V. Weatherford Co
1520 Beckett Avenue
Anaheim, CA 92811
TEL 714 694 9600
TWX 910 593 1354

R.V. Weatherford Co
1095 East Third Street
Pomona, CA 91768
TEL 714 623 2247
FAX 910 561 2811

R.V. Weatherford Co
3240 Redwood Avenue
Stanford Industrial Park
Palo Alto, CA 94304
TEL 415 493 5070

R.V. Weatherford Co
3511 W. Earl Drive
Phoenix, AZ 85017
TEL 602 272 7144
FAX 910 951 0034

Sterling Electronics
1608 6th Avenue South
Seattle, WA 98106
TEL 206 762 9120
TLX 32-9652

Western Microelectronics
915 Benicia Avenue
Sunnyvale, CA 94086
TEL 408 737 1640

CANADA

Future Electronics
1647 Ferner Street
Montreal, Quebec
CANADA H4P 1K3
TEL 514 735 1773
TWX 610 421 2221

EASTERN REGION

Zilog, Inc.
76 Treble Cove Road
No. Billerica, MA 01867
TEL 617 667 2179
TWX 710 347 6660

MIDATLANTIC REGION

Zilog, Inc.
P.O. Box 92
Bergenfield, NJ 07625
TEL 201 395 9158
TWX 710 991 9771

MIDWESTERN REGION

Zilog, Inc.
1701 Woodfield Place
Suite 417
Schaumburg, IL 60195
TEL 312 883 8080
TWX 910 291 1064

SOUTHWESTERN REGION

Zilog, Inc.
17982 Sky Park Circle
Suite C
Irvine, CA 92714
TEL 714 549 2891
TWX 910 395 2803

EUROPEAN HDQTS

Zilog (UK) Ltd.
Nicholson House
Maddenhead, Berkshire
England
TEL (0628) 35131 213
TWX 848 609

10460 Bubb Road, Cupertino, California 95014

Telephone: (408) 446-4666 TWX: 910-355-7621

03-0027-02

MSE-B-64

Printed in U.S.A.
Copyright ©1977 by Zilog, Inc.

APPENDIX C

16-BIT MICROPROCESSOR FAMILY

THIS PAGE INTENTIONALLY LEFT BLANK.

16-BIT MICROPROCESSOR FAMILY EXAMPLES

- MC - 68000 FAMILY
- Z - 8000 CPU
- Z - 8010 MMU
- Z - 8034 UPC
- Z - 8036 CIO
- Z - 8030 SCC



INTEGRATED
COMPUTER
SYSTEMS^{INC.}

THIS PAGE INTENTIONALLY LEFT BLANK.

MSE C-2

INTRODUCING THE MC68000...

MOTOROLA'S ADVANCED COMPUTER SYSTEM ON SILICON

The MC68,000 microprocessor is housed in a 64-pin package that allows the use of separate (non-multiplexed) address and data buses. This large package provides optimum flexibility while at the same time maintaining bus through-put.

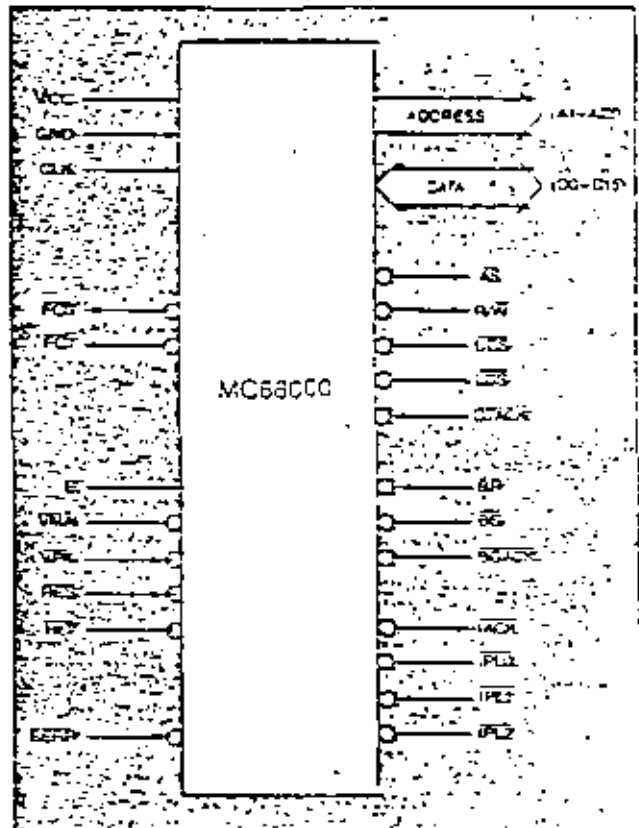

PIN IDENTIFICATION & DEFINITIONS

A1-A20	Address Leads	20-bit address bus: capable of addressing 16,777,216 bytes in conjunction with LDS and LDS.
D0-D15	Data Leads	16-bit data bus: transfers 8 or 16 bits of information.
AS	Address Strobe	Indicates valid address & provides a bus lock for indivisible operations.
R/W	Read/Write	Defines bus operation as Read or Write and controls external bus buffers.
UDS, LDS	Data Strobes	Identifies the bytes to be operated on according to R/W and AS.
DTACK	Data Transfer Acknowledge	Allows the bus cycle to synchronize with slow devices or memories.
BR	Bus Request	Input to the Processor from a device requesting the bus.
BG	Bus Grant	Output from the processor granting bus arbitration.
BGRACK	Bus Grant Acknowledge	Confirmation signal from BG indicating a valid selection from the arbitration process.
INT	Interrupt Acknowledge	Identifies that the bus is performing an interrupt service cycle.
PPL1, PPL2, PPL3	Interrupt Priority Level	Provides the priority level of the interrupting function to the processor.

FC1, FC2	Function Code	Provides external devices with information about the current bus cycle.
CLK	Clock	Master the clock to the processor.
RES	Reset	Provides reset indication signal to the processor and peripheral devices.
HIT	Halt	Stops the processor and allows single stepping.
BERR	Bus Error	Provides termination of a bus cycle if no response or an invalid response is received.
E	Enable	Enable clock for 68000 systems.
VPA	Valid Peripheral Address	Identifies addresses used as a 68000 compatible area.
VMA	Valid Memory Address	Indicates to 6800 family devices that a valid address is on the bus.
VCC	+5 Volts	
GND	Ground (2 pins)	

TYPICAL CELL GEOMETRIES

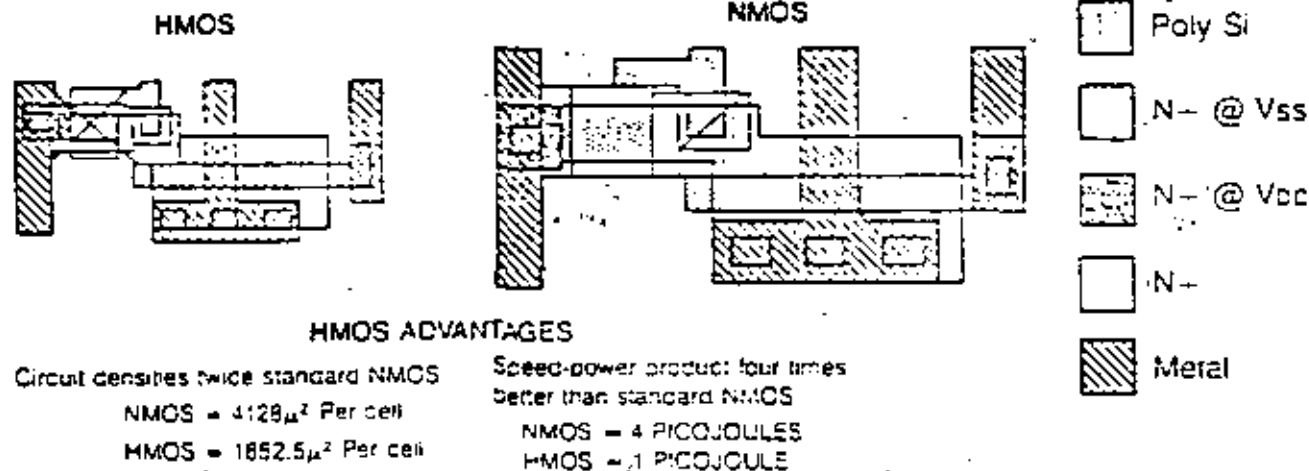

Figure 1: Comparison of HMOS and NMOS Technologies

HMOS Technology used for the MC68000 results in significant improvements to Circuit Densities and Speed-Power Products

Advances in semiconductor technology have provided the capability to put on a single silicon chip, a microprocessor at least an order of magnitude higher in performance and circuit complexity than has been previously available. The MC68000 is the first of a family of such VLSI microprocessors from Motorola. It combines state-of-the-art technology and advanced

circuit design techniques with computer sciences to weave an architecturally advanced 16-bit microprocessor containing over 58000 active devices on a silicon chip. This high density of active elements coupled with an order of magnitude increase in performance over the original MC6800 is the direct result of significant advances in semiconductor technology. Advances such as dry PLASMA etching, projection printing, and HMOS (High density short channel MOS) circuit design techniques (Figure 1) have provided a sound technological base that has allowed Motorola's system engineers, computer scientists and marketing engineers a large degree of innovative freedom. The goals of applying this innovative freedom to microprocessors are to make the microprocessor easy to use, more reliable and more flexible for applications, while maximizing performance.

The resources available to the MC68000 user consist of the following:

- 32-bit data and address registers
- 16 mega-byte direct addressing range
- 61 powerful instruction types
- operations on six main data types
- memory mapped I/O
- 14 addressing modes

Particular emphasis has been given to the architecture to make it orthogonal (regular) with respect to the registers, instructions (including all addressing modes), and data types. Orthogonality makes the architecture easy to learn and program, and, in the

process, reduces both the time required to write programs and the space required to store programs. The net result is a great reduction in the cost and risk of developing software.

High systems throughput (up to an aggregate of two million instruction and data word transfers per second) is achieved even with readily available standard product memories with comparatively slow access times. The design flexibility of the data bus allows the mixing of slow and fast memories or peripherals with the processor, automatically optimizing the transfer rate on every access to keep the system operating at peak efficiency.

The hardware design of the CPU was heavily influenced by advances made in software technology. High level language compilers as well as code produced from high level languages must run efficiently on the new generation 16-bit and 32-bit microprocessors. The MC68000 supports high level languages with its consistent architecture, multiple registers and stacks, large addressing range and high level language oriented instructions (LINK, UNLINK, CHK, etc.). Also, operating systems for controlling the software operating environment of the MC68000 MPU are supported by privileged instructions, memory management, a powerful vectored multi-level interrupt and trap structure, and specific instructions (EXG, LDM, STM, TRAP, etc.).

The processor also provides both hardware and software interlocks for multiprocessor systems. The CPU chip contains bus arbitration logic for a shared bus and shared memory environment (shared with other MC68000 processors, DMA devices, etc.). Multiprocessor systems are also supported with software instructions (TEST and SET, TEST and RESET, etc.). The MC68000 offers the maximum flexibility for microprocessor based multiprocessor systems.

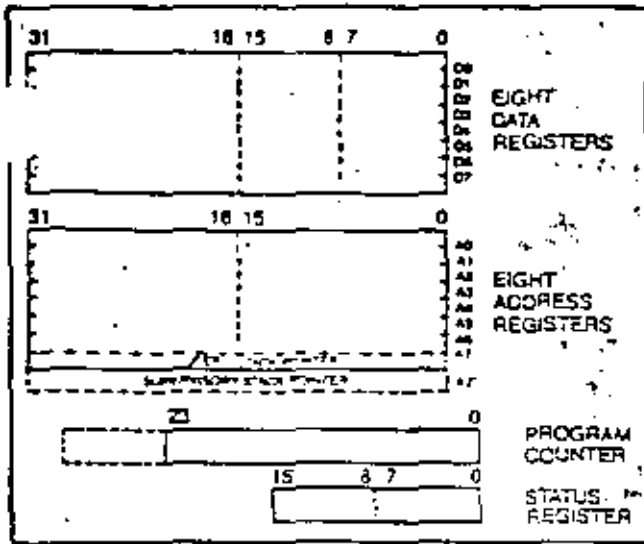

Figure 2: MC68000 Programming Model

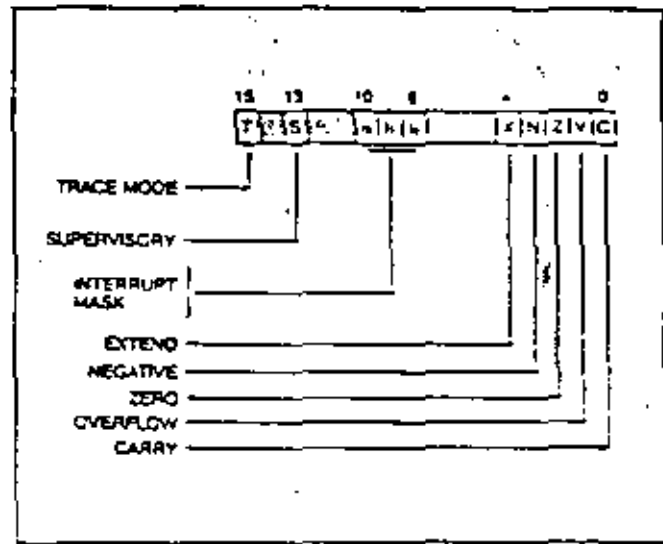

Figure 3: MC68000 Status Register

THE MC68000 CPU

Advanced architecture processors must not only offer efficient solutions to large complex problems but must be able to handle the small, swable problems with proportional efficiency. The CPU has been designed to offer the maximum in performance and versatility to solve simple and complex problems efficiently.

The MC68000 offers sixteen 32-bit registers in addition to the 24-bit program counter and 16-bit status register (Figure 2). The first eight registers (D0-D7) are used as data registers for byte (8-bit), word (16-bit) and long word (32-bit) operations. The second set of eight registers (A0-A7) may be used as software Stack Pointers and Base Address Registers. In addition, the second set of eight registers may be used for word and long word data operations. All of the sixteen registers may be used as Index Registers.

The 24-bit Program Counter provides a memory addressing range of more than 16 mega-bytes (actually 16,777,216 bytes). This large range of addressing capability, coupled with a Memory Management Unit, allows large, modular programs to be developed and operated without resorting to cumbersome and time consuming software bookkeeping and paging techniques.

The Status Register (Figure 3) contains the Interrupt Level Mask (8 levels available) as well as the Condition Code: Overflow (O), Zero (Z), Negative (N), Carry (C), and Extend (X). Additional status bits indicate that the processor is in a TRACE (T) mode or in a SUPERVISORY (S) state. Ample space remains in the Status Register for future extensions of the M68000 family.

Six basic data types are supported. These data types are:

- Bits
- Bytes (8-bits)
- BCD digits
- Words (16-bits)
- ASCII characters
- Long words (32-bits)

In addition operations on other data types such as memory addresses, status word data, etc. are provided for in the instruction set.

DEFINITIONS	
EA	= Effective Address
AR	= Address Register
DR	= Data Register
RA	= Address or Data Register Used as Index Register
SR	= Status Register
PC	= Program Counter
Dn	= Eighth Bit Offset
On	= Sixteen Bit Offset
N	= 1 for Byte, 2 for Word and 4 for Long word
()	= Contents of
-	= Replaces

TABLE I: MC68000 DATA ADDRESSING MODES

REGISTER DIRECT ADDRESSING

Data Register Direct: EA = Dn
 Address Register Direct: EA = ARn
 Status Register Direct: EA = SR

ABSOLUTE DATA ADDRESSING

A. Absolute Short: EA = (Next Word)
 B. Absolute Long: EA = (Next Two Words)

PROGRAM COUNTER RELATIVE ADDRESSING

Relative with Offset: EA = (PC) + Dn
 Relative with Index & Offset: EA = (PC) + (RA) + Cn

REGISTER INDIRECT ADDRESSING

Register Indirect: EA = (ARn)
 Post-increment Register Indirect: EA = (ARn), ARn ← ARn + N
 Pre-decrement Register Indirect: ARn ← ARn - N, EA = (ARn)
 Register Indirect with Offset: EA = (ARn) + Dn
 Indexed Register Indirect with Offset: EA = (ARn) + (Rn) + Cn

IMMEDIATE DATA ADDRESSING

Immediate: DATA = Next Word(s)
 Quick Immediate: INHERENT DATA

The 14 flexible addressing modes, shown in Table I, include five basic types:

- Register Direct - Immediate
- Register Indirect
- Absolute - Program Counter Relative

Included in the addressing modes is the capability to do Post-incrementing, Pre-decrementing, Overlaying and Indexing.

THE INSTRUCTION SET

The MC68000 instruction set is rich and full as evidenced by the 61 distinct types shown in Table II. Special emphasis during the design has been given to the instruction set's support of structured high-level languages that require ease of programming. Each instruction, with few exceptions, operates on bytes, words, and long words and most instructions can use any of the 14 addressing modes. Combining instruction types, data types, and addressing modes, over 1000 useful instructions are provided. These instructions include signed and unsigned multiply and divide, "quick" arithmetic operations, BCD arithmetic and extended operations (through steps). The processor offers the most comprehensive and flexible instruction set of any microprocessor of any class available today. Additionally, its highly orthogonal, proprietary microcoded structure provides a sound, viable base for the future.

REDUCED SOFTWARE COST AND RISK

Advances in VLSI semiconductor technology have resulted in a significant reduction in the cost of computer hardware in recent years. The MC68000 microprocessor, for example, provides in a single integrated circuit package computing power that just a decade ago would have been three or four orders of magnitude more expensive. Software costs during this same period of time have, as a percentage of total system cost, increased significantly. This has been due primarily to inflation and the labor intensive nature of programming. Without significant architectural advances in computers, this trend can do nothing but continue. One of Motorola's major goals in developing this new microprocessor has been to reduce the costs of software. Many innovative features have been incorporated to make programming easier, faster and more reliable.

An Orthogonal 16-BIT MPU — The highly orthogonal or regular structure of the MC68000 microprocessor greatly simplifies the effort required to write programs in Assembly Language as well as in High Level Languages. Operations on integer data in registers and memory are independent of the data itself. Separate special instructions that operate on byte (8-bit), word (16-bit) and long-word (32-bit) integers are not necessary. The programmer merely has to

remember one mnemonic for each type of operation and then specify data size, source addressing mode and destination addressing mode. This has helped keep the total number of instruction mnemonics for the MC68000 to an easily remembered, yet complete, 61 types, eleven fewer than on Motorola's MC6800.

The dual operand nature of many of the instructions significantly increases the flexibility and power of this new Motorola microprocessor. Consistency again is maintained since all data registers and memory locations may be either a source or destination for most operations on integer data.

TABLE II: MC68000 INSTRUCTION SET SUMMARY

MNEMONIC	DESCRIPTION
ABCD	Add Decimal with Extend
ADD	Add
ADDX	Add with Extend
AND	Logical And
ASL	Arithmetic Shift Left
ASR	Arithmetic Shift Right
BCC	Branch Conditionally
BCHG	Bit Test and Change
BCLR	Bit Test and Clear
BRA	Branch Always
BSET	Bit Test and Set
BSR	Branch to Subroutine
BTST	Bit Test
CHK	Check Register Against Bounds
CLR	Clear Operand
CMPI	Arithmetic Compare
CMPI	Decrement and Branch Non-Zero
CMPI	Signed Divide
CMPI	Unsigned Divide
CMPI	Exclusive-Or
EXG	Exchange Registers
EXT	Sign Extend
JMP	Jump
JSR	Jump to Subroutine
LMUL	Load Multiple Registers
LDD	Load Register Quick
LEA	Load Effective Address
LINK	Link Stack
LSL	Logical Shift Left
LSR	Logical Shift Right
MOVE	Move
MULL	Signed Multiply
MULL	Unsigned Multiply
NBCD	Negative Decimal with Extend
NEGX	Two's Complement
NEGX	Two's Complement with Extend
NOP	No Operation
NOT	One's Complement
OR	Logical Or
PACK	Pack ASCII to BCD
PEA	Push Effective Address
RESET	Reset External Devices
ROL	Rotate Left without Extend
ROTL	Rotate Left with Extend
ROTR	Rotate Right without Extend
ROTR	Rotate Right with Extend
RTR	Return and Restore
RTR	Return from Subroutine
SBCD	Subtract Decimal with Extend
SCC	Set Conditional
STM	Store Multiple Registers
STOP	Stop
SUB	Subtract
SUBX	Subtract with Extend
SWAP	Swap Data Register Halves
TAS	Test and Set Operand
TRAP	Trap
TRAPV	Trap on Overflow
TST	Test
UNLK	Unlink Stack
UNPK	Unpack BCD to ASCII

The addressing modes have been kept simple without sacrificing efficiency. All fourteen addressing modes operate consistently and are independent of instruction operation itself. Additionally, all address registers may be used for the Direct, Register Indirect, and indexed addressing modes. (Immediate, Program Counter Relative and Absolute addressing by definition do not use address registers). For increased flexibility, any data register — as well as any address register — may be used as an Index Register. Address register consistency is maintained for stacking operations since any of the eight address registers may be utilized as User Program Stack pointers with the Register Indirect Post-Increment/Pre-Decrement addressing modes. Register A7, however, is a special register that, in addition to its normal addressing capability, functions as the System Stack Pointer when starting the Program Counter and Status Register for subroutine calls, traps and interrupts while in the supervisory mode.

Structured Modular Programming — The art of programming microprocessors has evolved rapidly in the past few years. Numerous advanced techniques have been developed to allow easier, more consistent and reliable generation of software. In general, these techniques require that the programmer be more disciplined in observing a defined programming structure such as modular programming.

Modular programming allows a required function or process to be broken down in short modules or sub-routines that are concisely defined and easily programmed and tested. Such a technique is greatly simplified by the availability of advanced macro assemblers and block structured High Level Languages such as PASCAL. Such concepts are virtually useless, however, unless parameters are easily transferred between and within software modules that operate on a reentrant and recursive basis. (To be reentrant a routine must be usable by interrupt and non-interrupt driven programs without the loss of data. A recursive routine is one that may call or use itself). The MC68000 microprocessor provides the necessary architectural features to allow efficient reentrant modular programming. The "LINK" and "UNLINK" instructions reduce subroutine call overhead in two complementary instructions by allowing the manipulation of linked lists of data areas on the stack. The "STM" (Store Multiple Registers) and "LDM" (Load Multiple Registers) instructions also reduce subroutine call programming overhead. These allow the loading or storing, via an effective address, multiple registers that are specified by the programmer. Sixteen software trap vectors are provided with the "TRAP" instruction and are useful in operating system call routines or user generated "macro routines." Other instructions that support modern structured programming techniques are PEA (Push Effective Address), LEA (Load Effective Address),

RTR (Return to Restore) as well as the normal JSR, BSR and RTS.

Of course, the powerful vectored priority interrupt structure of the microprocessor allows straightforward generation of reentrant modular Input/Output routines. Eight maskable levels of priority with 192 vector locations provide maximum flexibility for I/O control. (A total of 256 vector locations are available for interrupts, hardware traps, and software traps.)

Improved Software Testability — One of the major tasks the system programmer encounters when writing software for microcomputers is the detection and correction of errors, or "debugging." The time taken to "debug" software nearly always exceeds the time it takes to write the software. In practice, the old 20/80 rule often applies: "The last 20% of the job requires 80% of the effort." The microprocessor incorporates several features that reduce the chance for errors. These features, such as Orthogonality and the Structured Modular Programming capability, have already been discussed.

Of major importance to the systems programmer are features that have been incorporated specifically to detect the occurrence of programming errors or "bugs." Several hardware traps, provided to maximize abnormal internal conditions of the MC68000 processor, detect the following error conditions:

- Word access with an odd address
- Illegal instructions
- Unimplemented instructions
- Illegal addressing mode
- Illegal Memory access (bus error)
- Overflow on divide (divide by zero)
- Overflow condition code (separate instruction TRAPV)

Additionally, the sixteen software TRAP instructions may be utilized by the programmer to provide applications oriented error detection or correction routines.

An additional error detection tool is the CHK (Check Register Against Bounds) instruction used for array bound checking by verifying that $0 \leq (REG) < LIMIT$. A trap occurs if the register contents are negative or greater than the limit.

Finally, the MC68000 includes a facility that allows instruction-by-instruction tracing of a program being debugged. This TRACE MODE results in a trap being made to a tracing routine after each instruction execution. The TRACE MODE is available to the programmer when the microprocessor is in the SUPERVISORY state as well as the USER state, but may only be entered while in the supervisory state. The SUPERVISORY/USER states provide an additional degree of error protection for the microprocessor by providing memory protection of selected areas of memory when an external memory management device is used.

Figure 4:
Motorola's
Microprocessor Evolution

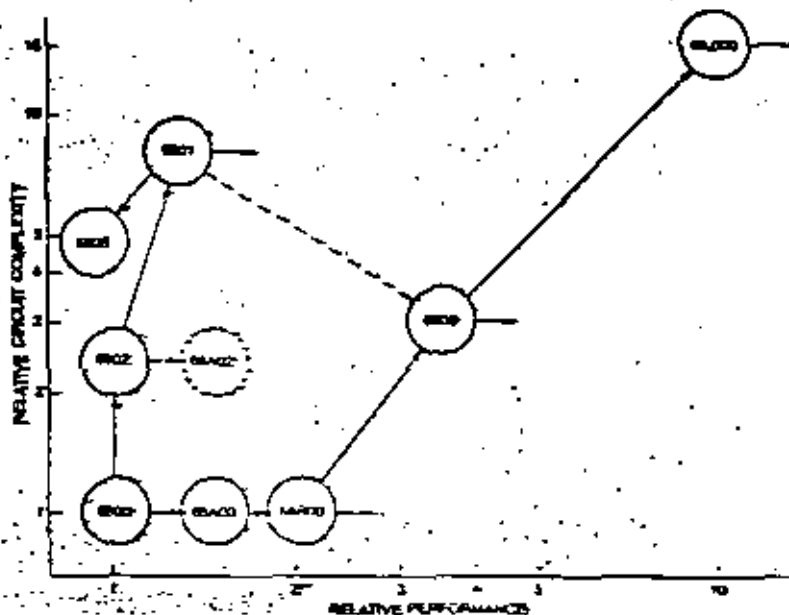

FUTURE FLEXIBILITY

Microprocessor VLSI circuit technology is advancing at an ever increasing rate. For example, the Motorola MC6800 — originally introduced in 1974 — has evolved into a number of more advanced products. This evolution has been along two paths: increased functionality, with the MC6802 and MC6803 computers, and increased performance with MC68A00, MC68800 and MC6809 microprocessors. (Figure 4). The sound, well planned, architectural base provided by the original MC6800 made it possible to develop these improved products while taking full advantage of the major speed and density enhancements to NMOS VLSI. This was accomplished while maintaining an unprecedented degree of compatibility and consistency with the original MC6800 MPU.

Similarly, a major consideration in the development of the MC68000 microprocessor has been to provide a good, solid, but flexible, base for future extensibility. Several architectural concepts have been incorporated that will allow this advanced product to be enhanced as semiconductor technological advances are made. For example, the highly orthogonal structure of the CPU allows operations on 8-bit, 16-bit and 32-bit integers without the need for concatenation of registers or multiplexing of internal data buses. This regular structure of the CPU lends itself to a more consistent, reliable design that can be easily expanded.

The MC68000 incorporates a proprietary multi-level micro-programmed structure that allows significant versatility in the implementation of instructions.

In fact, more than one-eighth of the instruction code map has been set aside specifically for implementation of future instructions. In the interim,

user implementation of instructions not currently in the instruction set is possible through the use of the TRAP instruction, as well as the hardware trap structure.

MEMORY MANAGEMENT OF LARGE ADDRESSING SPACE

The ever-decreasing costs of semiconductor memories in combination with the use of high level languages and sophisticated data operating systems allow Motorola's new generation of high performance microprocessors to be used in complex, memory intensive applications. In order to meet the needs of such applications, the MC68000 is capable of directly addressing more than 16 megabytes of memory. This large address space is directly accessed and managed very efficiently on a word or byte basis since operand size is specified by the instruction. The use of Upper Data Strobe (UDS) and Lower Data Strobe (LDS) signals allows easy access to high order bytes, low order bytes, or words.

Several additional useful features are provided that allow the programmer to efficiently manage memory usage. Powerful memory addressing modes such as Register Indirect, Indexed, Short and Long Absolute, and Program Counter Relative allow well-ordered access to specific memory locations. These addressing modes allow easy address calculations (Register Indirect and Indexed), direct access to memory location (Short and Long Absolute) and position independent or relocatable coding (Program Counter Relative). Of course, the Pre-decrement Post-increment Register Indirect Addressing modes also allow efficient management of data in memory.

by permitting the programmer to generate as many as eight concurrent stacks or queues. Another feature allows the programmer to manage the use of memory is the CRK (Check Register Against Bounds) instruction. This instruction permits the software implementation of a basic memory protection/management structure.

Still another significant feature provided in the MC68000 microprocessor is the distinction between a USER and a SUPERVISOR mode. The SUPERVISOR mode permits certain protected operations within the processor system. Of particular interest is that an external Memory Management Controller may be used when the processor is in the USER mode to manage the large address space for the programmer. The controller's memory management operations are transparent to the programmer when in the USER mode and can be changed or updated only in the SUPERVISOR mode. The Memory Management Controller provides both management of a variable number of variable size segments (Memory Segmentation) and dynamic management of multi-task memory relocation and protection. The Memory Management Controller regulates access to storage segments that are dedicated to read only data, read/write data, program code and protected data/code.

REDUCED CODE DENSITY AND IMPROVED SPEED

With the advent of low cost, very high density VLSI RAMS and ROMS, it might incorrectly be assumed that the number of bytes of code needed to execute a given program is no longer important. Code density, however, is very crucial, since microprocessor speed is highly dependent upon the number of executed instruction words. During the early development of Motorola's MC68000 microprocessor, extensive studies were made of the use of instructions and sequences of instructions in many microprocessor applications. These studies identified not only statically frequent instructions but also dynamically frequent instructions. (The dynamic frequency of instructions is a measure of how often an instruction is executed while static frequency is a measure of how often it occurs in a program listing or is encountered by an assembler). The major contributor to the in-

creased efficiency, as a result of the studies, is the highly regular or orthogonal structure of the architecture. The consistency of the architecture, instruction set, and addressing modes significantly reduces the number of instructions needed to accomplish a given task. Additionally, many instructions have been included to specifically improve code density and speed. For example, single word Add and Subtract instructions using Quick Immediate addressing are fast, small value arithmetic operations on data registers and memory. A Load Quick Immediate (LDQ) provides the ability to load a small (2-bit) signed word into any register in a single word operation. In order to improve the speed of loop operators, a single word instruction for Decrement Count by One and Branch if non-zero (DCNZ) is included. Of course, the TRAP, Store Multiple Registers (STM), Load Multiple Registers (LDM), Link Stack (LINK), Unlink Stack (UNLK) and Check Limit (CHK) instructions significantly reduce code requirements for subroutines, operating system calls and stacking operations.

Other instructions that help reduce coding requirements and improve performance of arithmetic operations are Signed and Unsigned Multiply (MULS and MULU), Signed and Unsigned Divide (DIVS and DIVU), BCD Arithmetic (ABCD, SBOD, RACK and UNPK) as well as the standard binary integer operations. In order to improve the efficiency of moving or transferring data, a powerful MOVE data instruction has been incorporated that allows the transfer of bytes, words and long words and operates in all data addressing modes. Thus, register-to-register, register-to-memory, memory-to-register and memory-to-memory transfers are permitted.

In addition to the powerful instructions that provide a substantial improvement in processor throughput, numerous architectural features significantly reduce the execution times for all instructions. The separate (non-multiplexed) address and data buses, instruction pre-fetch pipeline and 32-bit internal registers are major contributors to the processor's unequalled performance. As an example of the performance capability of the MC68000 Table III and the accompanying graphs in Figures 5 and 6 summarize the execution times for a number of common instructions. For comparison purposes, similar information is provided for Zilog's Z-8000 microprocessor. It is interesting to note that the MC68000 has significantly faster execution times.

TABLE IV — EXECUTION TIMES FOR MOVE R, SAC INSTRUCTION FOR VARIOUS ADDRESSING MODES

Source Addressing	Motorola MC68000	Z8000 Z-8000
Register	0.5us	0.75us
Indirect Register	1.0	1.75
Absolute Addressing (Direct)	1.5	2.25
Indexed Addressing	1.5	2.50
Immediate	1.0	1.00

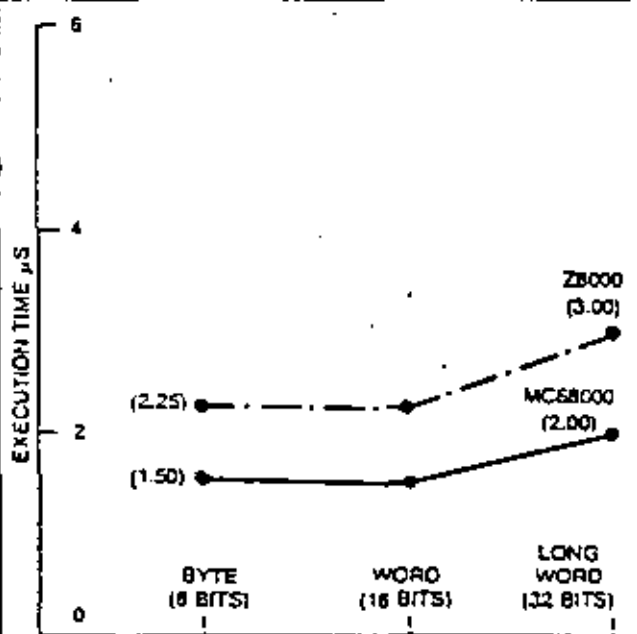

FIGURE 5: Execution Time for the Add Data Element to a register from a short Absolute Address Instruction.

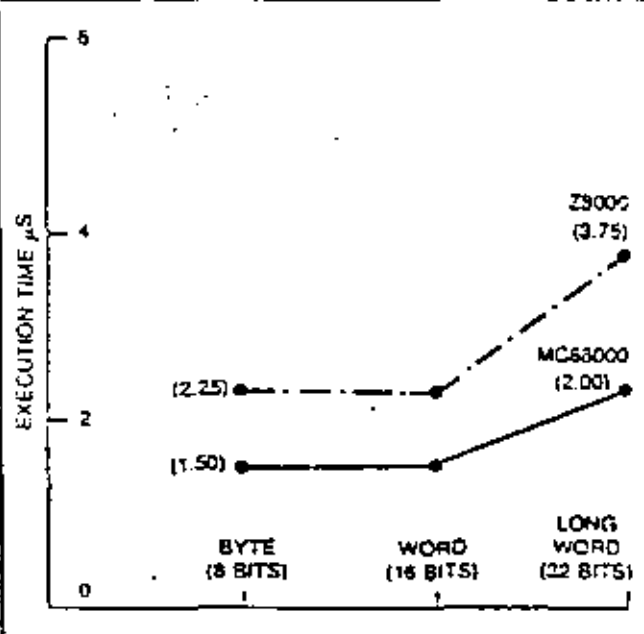

FIGURE 6: Execution Time for the move a data element from memory to a register from short Absolute Address Instruction.

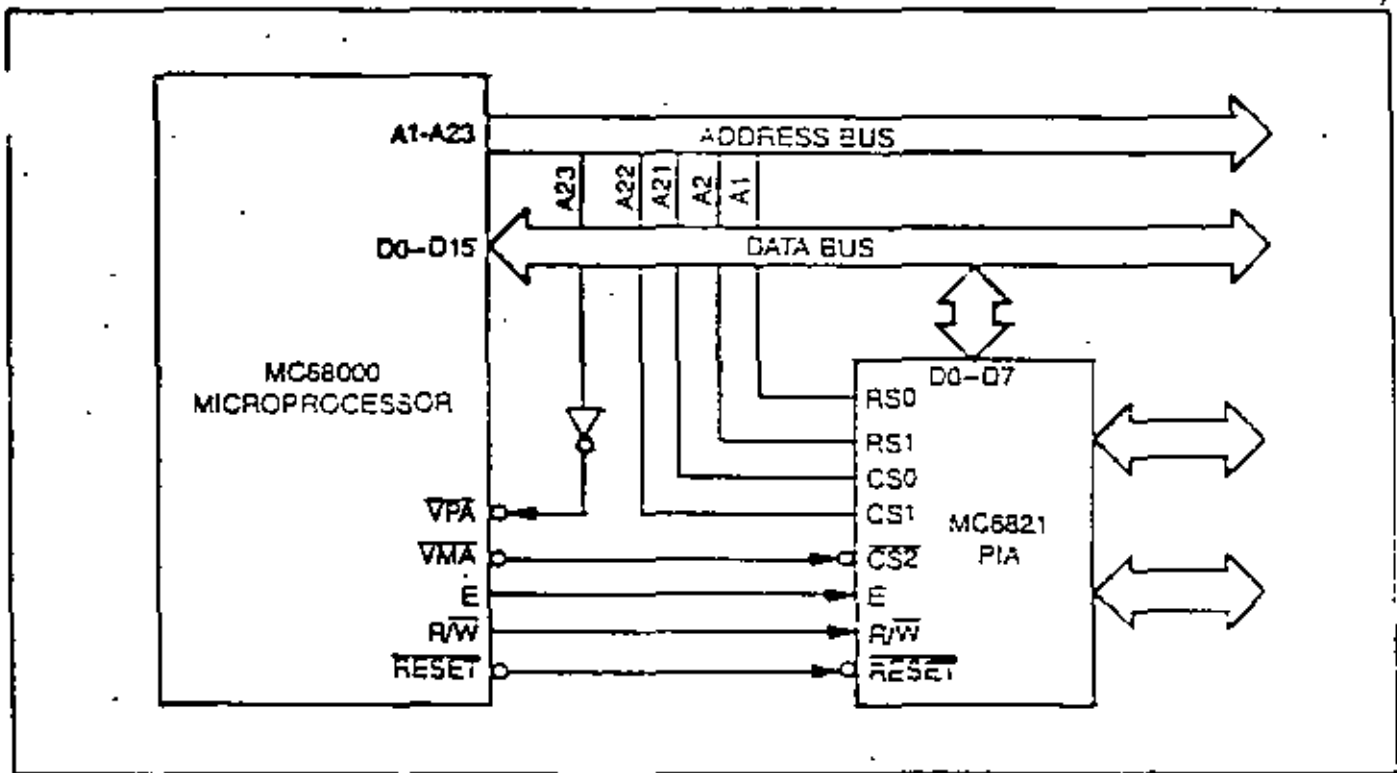

Figure 7: Example of MC68000 Interface Connections for MC6821 Peripheral Interface Adapter

SOFTWARE SUPPORT AND MC68000 COMPATIBILITY

The system designers and programmers using the MC68000 in an application have available a complete, compatible system of hardware and software. The microprocessor is supported by a full range of software development tools including disc operating systems, debug aids, assemblers, and high level languages. In addition, a translator will allow the present M6800 Family user to convert existing programs to run on the MC68000 with a minimum of programmer intervention.

The careful planning of this new microprocessor provides a superset of the MC6800 instruction set enhanced by the addition of more and larger registers, powerful orthogonal structure and many flexible addressing modes. This allows efficient translation of existing MC6800 programs, which can then be further optimized by taking full advantage of the versatile and powerful features of the MC68000.

This careful planning of similarities between the

MC68000 and the MC6800 does not stop at software compatibility (by transition) but also extends to peripheral controller interfacing. Motorola's extensive line of intelligent M6800 family peripherals including the MC6844 Advanced Data Link Controller and the MC68452 General Purpose Interface Adapter can be directly and easily interfaced to the MC68000. Three signal lines: Enable (E), Valid Memory Address (VMA), and Valid Peripheral Address (VPA) are provided to simplify the interface to Motorola's standard MC6800 peripherals as shown in Figure 7. Interface to the new MC6801E (Single Chip Programmable Controller) is also possible, allowing user implementation of specialized input/output functions. In addition, the MC68000 is supported by unique peripheral controllers expected of an advanced architecture microprocessor, including a DMA Controller and a Memory Management Unit.

The MC68000 is not just a component. By a unique blend of VLSI design, software engineering and careful planning, the MC68000 is Motorola's Advanced Computer System on Silicon.



MOTOROLA Semiconductor Products Inc.

PO. BOX 29112 • PHOENIX, ARIZONA 85026 • A SUBSIDIARY OF MOTOROLA INC.

Z8001/Z3002 CPU 27

Central Processing Unit



Product Brief

August 1979

Features

- Regular, easy-to-use architecture.
- Instruction set more powerful than many minicomputers.
- Directly addresses 8M bytes.
- Eight user-selectable addressing modes.
- Seven data types that range from bits to 32-bit long words and word strings.
- System and normal operating modes: separate code, data and stack spaces.

- Sophisticated interrupt structure.
- Resource-sharing capabilities for multiprocessing systems.
- Multi-programming and compiler support.
- Memory management and protection provided by Z8010 Memory Management Unit.
- 32-bit operations, including signed multiply and divide.
- Z-Bus compatible.

Description

The Z8000 is an advanced high-end 16-bit microprocessor that spans a wide variety of applications ranging from simple stand-alone computers to complex parallel-processing systems. Essentially a monolithic minicomputer central processing unit, the Z8000 CPU is characterized by an instruction set more powerful than many minicomputers; resources abundant in registers, data types, addressing modes and addressing range; and a regular architecture that enhances throughput by avoiding critical bottlenecks such as implied or dedicated registers.

CPU resources include sixteen 16-bit general-purpose registers, seven data types that range from bits to 32-bit long words and word strings, and eight user-selectable addressing modes. The 110 distinct instruction types can be combined with the various data types and addressing modes to form a powerful set of 414 instructions. Moreover, the instruction set exhibits a high degree of regularity; most instructions can use any of the five main addressing modes and can operate on byte, word and long-word data types.

The CPU can operate in either system or normal modes. The distinction between these two modes permits privileged operations, thereby improving operating system organization and implementation. Multiprogramming is

supported by the "atomic" Test and Set instruction; multiprocessing by a combination of instruction and hardware features; and compilers by multiple stacks, special instructions and addressing modes.

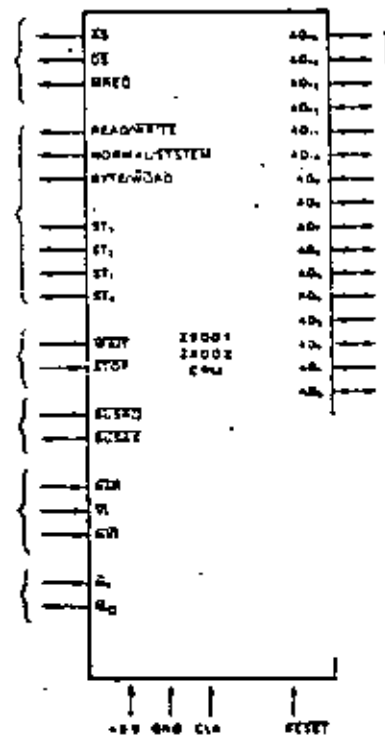

Figure 1. Pin 1

Description
(Continued)

The Z8000 CPU is offered in two versions: the Z8001 48-pin segmented CPU and the Z8002 40-pin non-segmented CPU. The main difference between the two is in addressing range. The Z8001 can directly address 8M bytes of memory; the Z8002 directly addresses 64K bytes. The two operating modes—system and normal—and the distinction between code, data and stack spaces within each mode allows memory extension up to 48M bytes for the Z8001 and 254K bytes for the Z8002.

To meet the requirements of complex, memory-intensive applications, a companion memory-management device is offered for the Z8001. The Z8010 Memory Management Unit manages the large address space by providing features such as segment relocation and memory protection. The Z8001 can be used with or without the Z8010. If used by itself, the Z8001 still provides an 8M byte direct addressing range, extendable to 48M bytes.

Register Organization. The Z8000 CPU is a register-oriented machine that has sixteen 16-bit general-purpose registers. The Z8002 CPU has one stack pointer register, and the Z8001 has two.

Stacks. The Z8001 and Z8002 can use stacks located anywhere in memory. Two implied stack pointers are available: the system stack pointer and the normal stack pointer.

Refresh. The Z8000 CPU contains a counter that can be used to refresh dynamic memory automatically.

Program Status Registers. This group of status registers contains the program counter, flags, and control bits. These are automatically saved when an interrupt or trap occurs, and a new status group is loaded.

Interrupt and Trap Structure. The CPU supports three types of interrupts: vectored and nonvectored maskable, and nonmaskable. There are four traps: system call, unimplemented instruction, privileged instruction, and segmentation trap.

Data Types. Z8000 instructions can operate on bits, BCD digits (4 bits), bytes (8 bits), words (16 bits), long words (32 bits), byte strings and word strings up to 64K bytes long.

Segmentation and Memory Management. The Z8001 can directly access 8M bytes of address space, using a segmented address-

ing scheme, implemented via the Z8010 MMU Memory Management Unit. The 8M bytes of Z8001 address space is divided into 128 relocatable segments of up to 64K bytes each. The addresses entered into instructions and output by the CPU in executing them are *logical addresses*. The MMU translates these logical addresses into addresses in physical memory. This process—relocation—is transparent to the user software.

Addressing Modes. Eight addressing modes are provided in the instruction set: Register (R), Immediate (IM), Indirect Register (IR), Direct Address (DA), Indexed (X), Relative Address (RA), Base Address (BA), and Base Indexed (BX).

Input/Output. A set of I/O instructions performs 8-bit or 16-bit transfers between CPU and I/O devices.

Multimicroprocessor Support. A pair of CPU pins is used in conjunction with certain instructions to coordinate multiple microprocessors.

Instruction Set. The Z8000 has in its repertoire the nine categories of instructions following:

- Load and exchange
- Arithmetic
- Logic
- Program control
- Bit manipulation
- Rotate and shift
- Block transfer and string manipulation
- Input/output
- CPU control

Status Lines. Seven pins of the Z8000 are dedicated to the issuance of status information. Three are the function select lines Read/Write/Normal/System, and Byte/Word. The other four lines (ST₀-ST₃) issue codes denoting type of operation (program or I/O reference, data or stack memory request, or internal operation), acknowledging external requests (segment trap or interrupt), and initiating memory refresh cycles.

Z8010 MMU Memory Management Unit

Product Brief

Preliminary

August 1979



Features

- Dynamic segment relocation makes software addresses independent of physical memory addresses.
- Sophisticated access validation protects memory areas from unauthorized or unintentional access.
- MMU architecture supports multiprogramming systems.

Description

Declining memory costs coupled with the increasing power of microprocessors has accelerated the use of high-level languages, sophisticated operating systems, complex programs and large data bases in microcomputer systems. The Z8001 microprocessor CPU supports these trends with an eight megabyte direct address space as well as a rich and powerful instruction set. The Z8010 Memory Management Unit (MMU) provides flexible and

Sixty-four variable-sized segments from 256 to 64K bytes can be managed within a total physical address space of 16M bytes; all 64 segments are randomly accessible.

Multiple MMUs can support several translation tables for each of the six Z8001 address spaces.

efficient support for this large address space by offering dynamic segment relocation, as well as numerous memory-protection features.

The primary memory of a computer is one of its major resources. As such, the management of this resource becomes a major concern as demands on it increase. These demands arise from multiple users (or multiple tasks within a dedicated application), the need to increase system integrity by limiting access

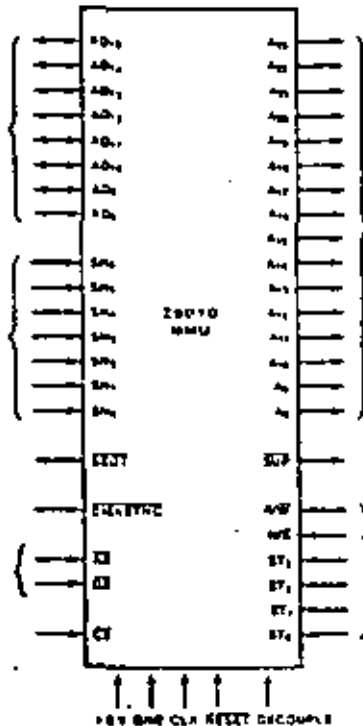

Figure 1. Pin Functions

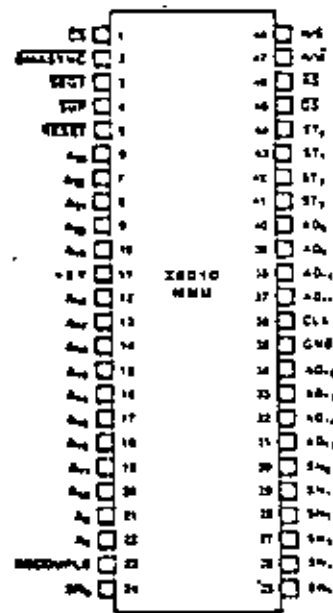

Figure 2. Pin Assignment

MSE C-15

Description
(Continued)

to various portions of the memory, and from the need to structure large, complex programs and systems.

Multiple tasks (or users) of a system that can reside anywhere in memory are called *relocatable*. Generally, systems in which all tasks are relocatable offer far greater flexibility in responding to changing system environments. Another aspect of multiple-task environments is sharing: separate tasks can execute the same program on different data, or several tasks may execute different programs using the same data.

Unfortunately, a problem that arises in multiple-task systems is that of system integrity. Tasks must be protected from unwanted interactions with other tasks; user tasks must be prohibited from performing operating system functions; and user tasks must also be protected from themselves so they cannot overflow the areas allotted to them.

In addition to these considerations, support for the design and implementation of large, complex programs and systems is itself an important consideration. Modern trends are toward the partitioning of a complex task into small, simple, self-contained subtasks that have well-defined interfaces. Because these subtasks interact with each other, communication between them must be carefully controlled. Memory-management systems can offer effective solutions for implementing large systems modularly designed.

The Z8010 Memory Management Unit supports multiple-process and large modular software systems with dynamic segment relocation. Furthermore, it enhances system integrity with

a powerful set of memory protection features.

Relocation. Dynamic segment relocation makes user software addresses independent of the physical memory addresses, thereby freeing the user from specifying where information is actually located in the physical memory and providing a flexible, efficient method for supporting multi-programming systems.

The Z-MMU uses a translation table to transform the 23-bit logical addresses from the Z8001 CPU into 24-bit addresses for the physical memory. Memory segments are variable in size from 256 bytes to 64K, in increments of 256 bytes. Pairs of Z-MMUs support the 128 segment numbers available for the various Z8001 CPU address spaces. Within an address space, any number of Z-MMUs can be used to accommodate multiple translation tables for system and normal operating modes or to support more sophisticated memory-management systems.

System Integrity. Z-MMU memory-protection features safeguard memory areas from unauthorized or unintended access by associating special access restrictions with each segment. A segment is assigned a "personality" consisting of several attributes when it is initially entered into the Z-MMU. When a memory reference is made, these attributes are checked against the status information supplied by the Z8001 CPU. If a mismatch occurs a trap is generated and the CPU is interrupted. The CPU can then check the status registers of the MMU to determine the cause and take appropriate action to correct the problem.

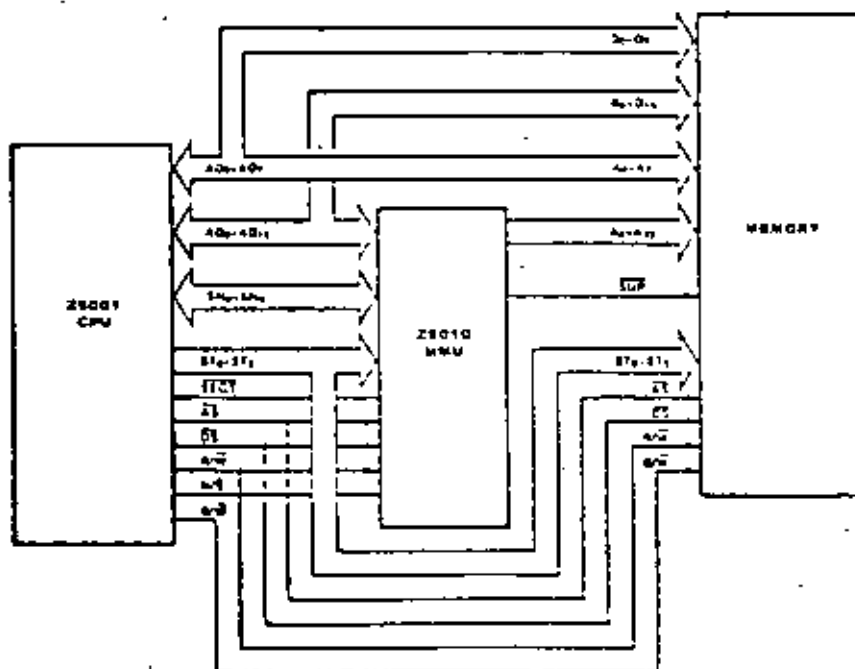

Figure 2. The MMU in a Z8000 System.

Z8034 UPC Universal Peripheral Controller

81



Product Brief

Preliminary

August 1979

Features

- Complete slave microcomputer, for distributed-processing Z-bus use.
- Unmatched power of Z8 architecture, instruction set.
- Three programmable I/O ports, two with 2-wire handshake, or any combination of data and control lines.
- Six levels of priority interrupts to Z-UPC.

- Two programmable 8-bit counters/timers with 6-bit prescalers.
- 256 byte register file, accessible by both master CPU and Z-UPC, as allocated by Z-UPC program.
- 2K bytes of on-chip program ROM for efficiency, versatility.

Description

The Z-UPC Universal Peripheral Controller is a distributed microcomputer that performs the three basic interfacing functions needed to interface a CPU with peripherals: device control by ROM-resident internal software, data manipulation, such as reformatting or arithmetic, and data buffering in internal registers.

The Z-UPC is similar to the Z8 microcomputer and uses the Z8 instruction set. Under

program control, its three 8-line I/O ports can be tailored to the needs of its user. Permanently configured as a single-data controller with 2K bytes of internal ROM, the Z-UPC executes instructions in 2.2 μ s average using a 4-MHz clock source. Its register file contains 256 bytes, of which 224 are general-purpose registers, 19 are status and control registers, and three are port registers.

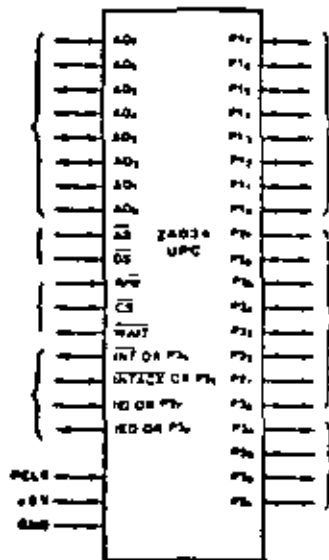

Figure 1. Pin Functions

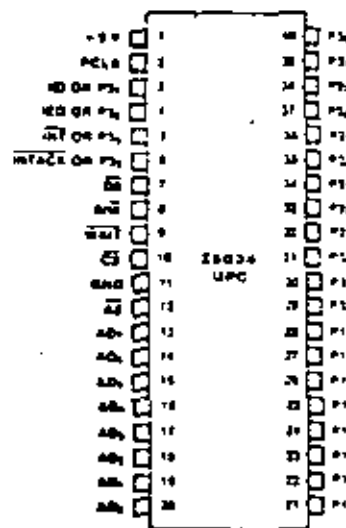

Figure 2. Pin Assignments

**Description
(Continued)**

The Z-UPC Universal Peripheral Controller is an intelligent device that generates all the control signals peripheral devices need. Because it does off-line arithmetic, translates data before transmitting, and buffers data, the Z-UPC unburdens the master CPU, thereby increasing the overall speed and efficiency of the system to which it resides.

Based upon the Z8 microcomputer architecture, the Z-UPC offers fast execution time, efficient use of memory, and sophisticated interrupt, I/O, and bit manipulation. Its powerful and extensive instruction types, combined with its efficient internal register addressing scheme, not only speeds program execution, but also efficiently packs program into the on-chip ROM.

A unique characteristic of the Z-UPC is its register file, which contains I/O port and control registers that can be accessed both by the Z-UPC program and by its associated master CPU. This results in byte efficiency, programming efficiency, and address space efficiency because Z-UPC instructions can operate directly on I/O data without moving it to and from an accumulator. It also allows the Z-UPC user to allocate as data buffer between the CPU and

the peripheral all register space not in use as accumulators, address pointers, index registers, or stack. Registers not used as buffer are protected against CPU access. The register file is divided into 16 groups of 16 working registers each. A register pointer uses fast, short-format instructions to access any one of these groups quickly, resulting in fast and easy task switching. Two-way communication between the master CPU and the register file is facilitated by another pointer that positions 16 interface registers anywhere within the register file. These registers are accessed directly by both the master CPU and the slave Z-UPC. Four more registers, similarly accessed, convey control and status information.

All of the Z-bus's daisy-chained priority interrupt system can be implemented in the Z-UPC under software control, or the Z-UPC can be programmed to function in a polled environment. In all, the Z-UPC has 34 pins that can be dedicated to I/O functions. Grouped logically into three 8-line ports, they can be programmed in many combinations of inputs, outputs, and bidirectional lines, with or without handshake and with push-pull or open-drain outputs.

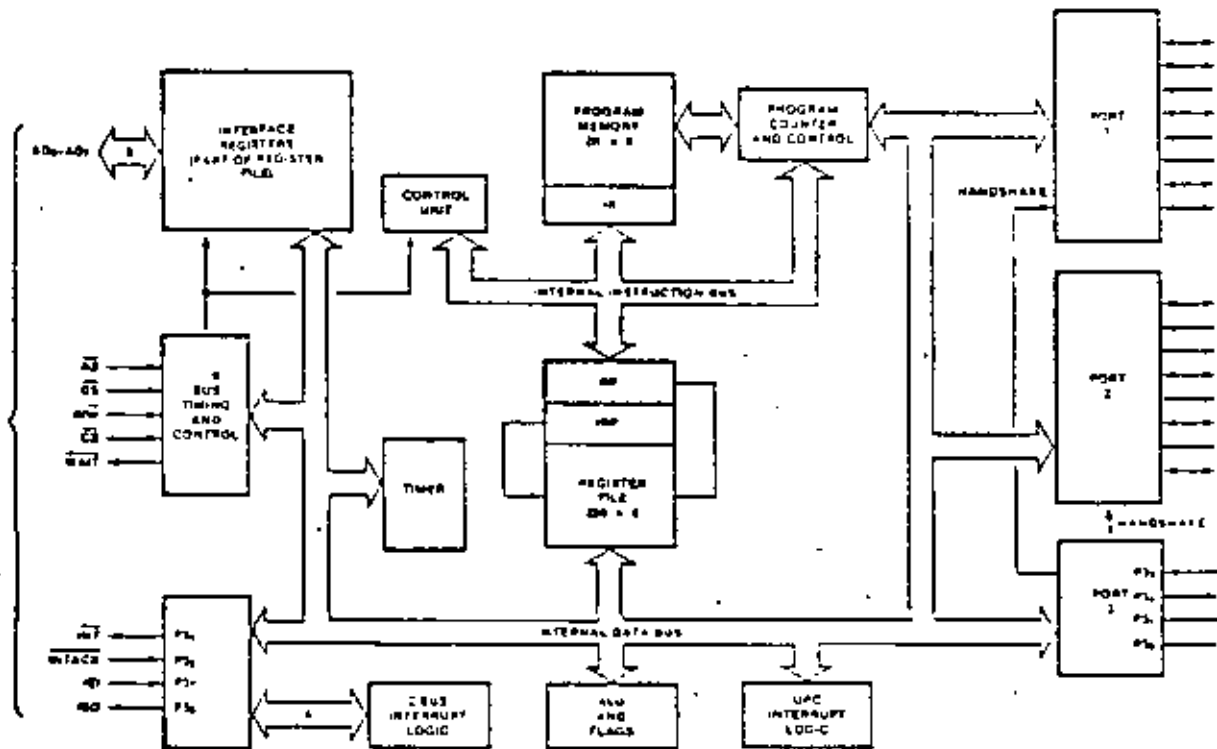

Figure 3. Functional Block Diagram

Z8036 CIO Counter/Timer and Parallel I/O Unit



Product Brief

Preliminary

August 1979

Features Two independent 8-bit double-buffered bidirectional I/O ports plus a special-purpose 4-bit I/O port.
Four handshake modes including IEEE-488.
Wait/Request line for high speed data transfer.

Three independent 16-bit counters.
All registers read/write and directly addressable.
Flexible pattern recognition logic, programmable as 16-input interrupt controller

Description The Z8036 CIO Counter/timer and Parallel I/O element is a general purpose peripheral circuit that satisfies most counter/timer and parallel I/O needs encountered in system designs. This versatile device contains three I/O ports and three counter/timers. Many programmable options tailor its configuration to specific applications. The use of the device is simplified by making all internal registers (command, status, and data) readable and (except for status bits) writable. Also, each register is given its own unique address so it can be accessed directly—no special sequential operations are required. The Z-CIO is directly Z-bus compatible.

Either 8-bit I/O port can be a handshake

byte port or a bit port. In the bit mode, data direction is programmable bit by bit. In the handshake mode, the ports can be input, output, or bidirectional, and they may be linked to form a 16-bit port. The four handshake modes include IEEE 488, interlocked, non-interfacing to a Z-UPC, Z-FIO or another Z-CIO, strobed and pulsed. The pulsed mode connects one counter/timer with the handshake logic for interfacing a mechanical device such as a printer. The 4-bit port provides handshake controls, special controls (Wait/Request) or general-purpose I/O.

The counter/timer section contains three 16-bit counters, two of which can be software-configured as a 32-bit counter/timer. Up to

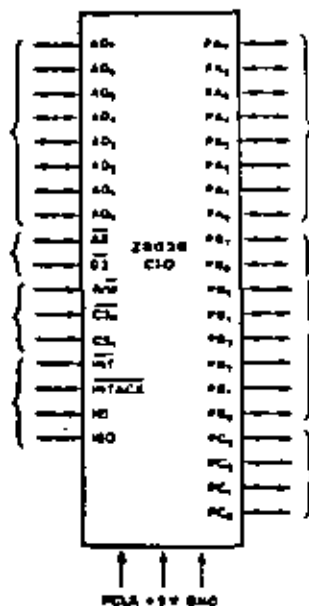

Figure 1. Pin F

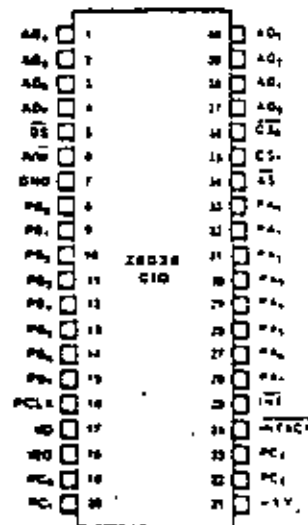

Figure 2. Pin J

MSE C-19

Description
(Continued)

four I/O lines for each counter are available for direct external control and status information. All counters have a programmable output duty cycle, continuous or single-cycle operation, and the counting process can be programmed to be either retrigged or nonretrigged.

Figure 3 shows how the Z-CIO is used. The two general purpose 8-bit ports are similar. They can be programmed as handshake driven, double-buffered ports (input, output, or bidirectional) or as control ports in which the direction of each bit is individually programmable. Port B can also be specified to provide external access for two of the counter/timers. Each port includes pattern recognition logic allowing interrupt generation when a specified pattern is detected. The pattern recognition logic can be programmed so that the port functions like a priority interrupt controller.

To control these capabilities, each port contains 13 registers. Three of these, the input, output, and buffer registers, are data path registers. Two others, the mode specification and handshake specification registers, define the mode of the port and specify what handshake to use, if any. The reference pattern for the pattern recognition logic is defined in three registers, the pattern polarity, pattern transition, and pattern mask registers. The detailed characteristics of each bit path (for example, the direction of data flow, or whether a path is inverting or noninverting) are programmed using the data path polarity, data direction, and special I/O control registers. The primary control and status bits are grouped in a single register so that after the ports are configured initially, only this register

need be accessed often. One register contains the interrupt vector associated with each port. To facilitate initialization, the port logic is designed so that if a capability of the port is not required the registers associated with that capability are ignored and need not be programmed.

The function of port C depends upon the roles of ports A and B. Port C provides handshake lines for the other two when required. Any bits of port C not so used can be used as I/O lines or as external access to the three counter/timer.

Besides the data input and output registers, three registers are needed. These specify the details of each bit path: data path polarity, data direction, and special I/O control.

The three counter/timers are all identical. Each is composed of a 16-bit down-counter, a 16-bit time constant register (which holds the value loaded into the down-counter), a 16-bit current count register (used to read the contents of the down-counter), and two 8-bit registers for control and status: the mode select and control registers. All three share a common vector register.

Each counter/timer can be programmed as either counter or timer. Up to four port I/O lines can be designated as external access lines for it. The lines are: Counter Input, Gate Input, Trigger Input, and Counter/Timer Output. Three different counter/timer output duty cycles are available: pulse, one-shot, or square wave. The operation of the counter/timer can be specified to be either single cycle or continuous. The counting sequence may be retrigged or nonretrigged, under program control.

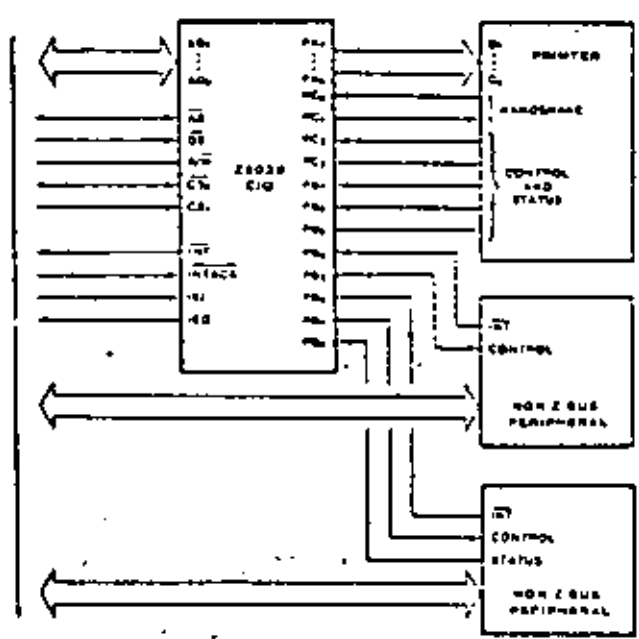

Figure 3. Functional Block Diagram

28030 SCC Serial Communications Controller

85



Product Brief

Preliminary

August 1979

Features

- Two independent, 0 to 1 Megabit-per-second, full-duplex channels, each with its own quartz oscillator, baud-rate generator, and digital phase-locked loop for clock recovery.
- Multi-protocol operation under program control.
- Asynchronous mode with 5 to 8 bits and 1, 1½, or 2 stop bits per character; programmable clock factor; break detection and generation; parity, overrun, and framing error detection.
- Local loopback and auto-echo modes.

- Bisynchronous mode with internal or external character synchronization on one or two sync characters and CRC generation and checking with CRC-16 or CRC-CCITT preset to either 1s or 2s.
- SDLC/HDLC mode with comprehensive frame-level control, automatic zero insertion and deletion, 1-field residue handling, error generation and detection, CRC generation and checking, and loop mode operation.
- Programmable for NRZ, NRZI, or FM coding.

Description The Z-SCC Serial Communication Controller is a dual-channel, multi-protocol data communication peripheral for Z-bus use. It is software-configured to satisfy a wide variety of serial communication applications. Its basic function is serial-to-parallel and parallel-to-serial conversion. However, the Z-SCC also contains a repertoire of new, sophisticated internal functions that minimize the need for

external random logic on the circuit card. The Z-SCC handles asynchronous formats, synchronous byte-oriented protocols such as IBM Bisync, and synchronous bit-oriented protocols such as HDLC and IBM SDLC. This versatile device also supports virtually any other serial data transfer application (cassette or diskette interface, for example). The device can generate and check CRC

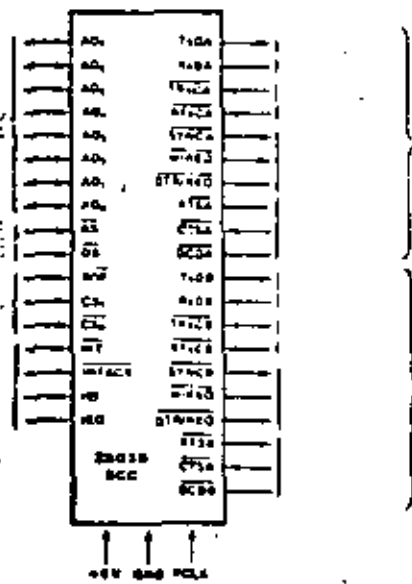

Figure 1. Pin Functions

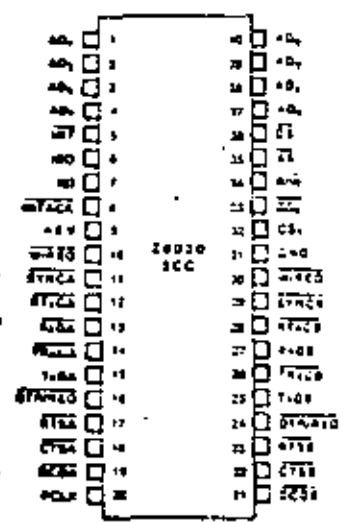

Figure 2. Pin Assignments

MSE C-21

**Description
(Continued)**

codes in any synchronous mode and can be programmed to check data integrity in various modes. It also has facilities for modem controls in both channels. In applications where these controls are not needed, the modem controls can be used for general-purpose I/O.

As is standard among Zilog peripheral components, the Z-bus daisy-chain interrupt hierarchy is supported.

The Z-SCC contains the necessary multiplexed address/data bus interface with strobe and chip select lines to function as a Z-bus peripheral. It includes internal control and interrupt logic, two full-duplex channels and two baud-rate generators. Associated with each channel are several read and write registers for mode control as well as the logic necessary to interface to modems or other external devices.

The read and write register group for each channel includes eight control registers, two sync-character registers, and four status registers. Each baud rate generator has two read/write registers for holding the time constant that determines baud rate. Associated with the interrupt logic is a write register for interrupt vector and three read registers: vector with status, vector without status, and interrupt pending status.

The logic for both channels provides formatting, synchronization and validation for data transferred to and from the channel interface. The modem control inputs are monitored by the control logic under program control. All of the modem control signals are general purpose in nature and optionally can be used for functions other than modem controls.

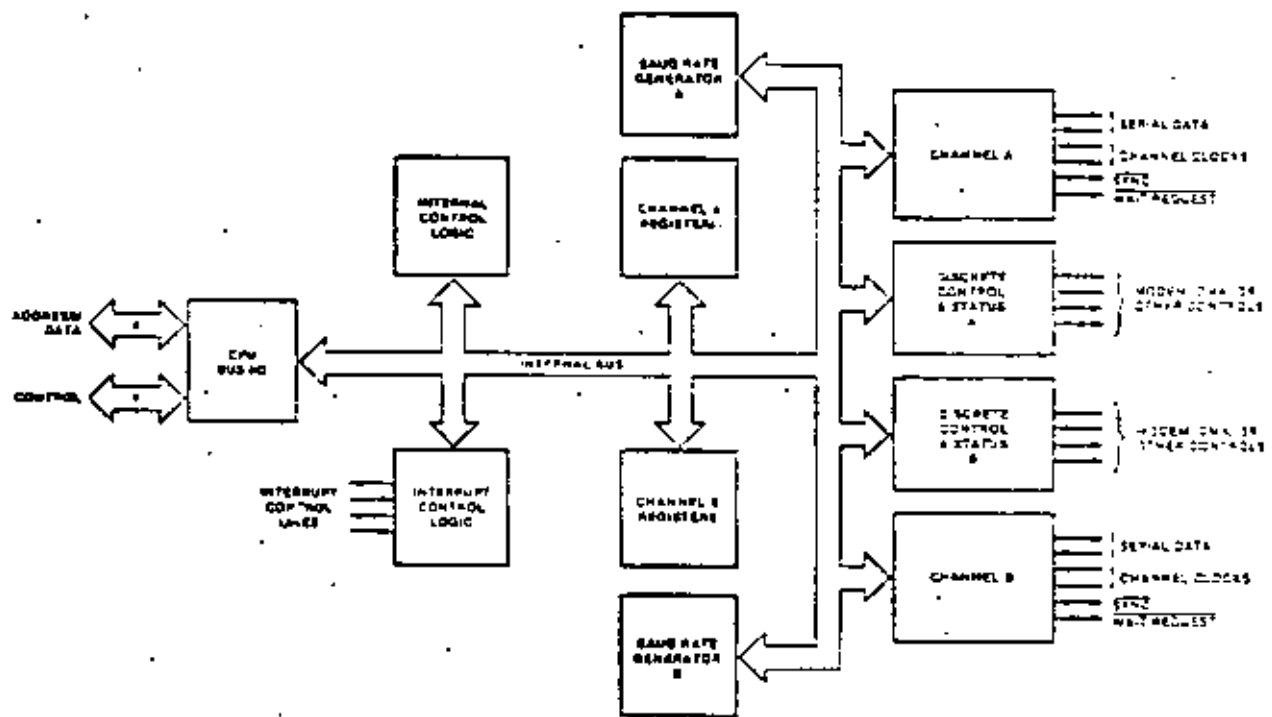

Figure 3. Functional Block Diagram

**Typical
Applications**

Figure 4 shows how a Z-SCC can be connected with channel A programmed for the Synchronous Data Link Control (SDLC) Loop mode, functioning as a secondary station. If NRZI or FM coding is used, no clock lines are required because the clock can be recovered from the received data, using the Z-SCC's on-chip digital phase locked loop (DPLL). Another Z-SCC (not shown), programmed for the SDLC mode, would be the controlling station, polling the loop for traffic. The figure shows a typical, asynchronous serial port being serviced by channel B of the Z-SCC. It could just as well support another synchronous data link, or even a high-speed link, transferring data via a DMA controller.

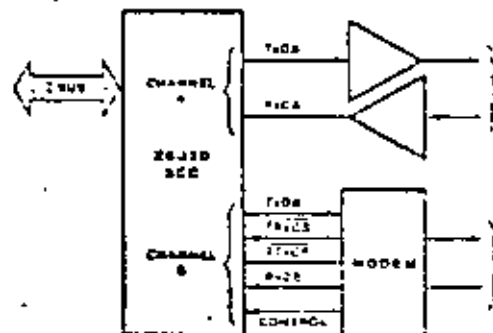

Figure 4. Loop Secondary Station and Serial Port

TABLE OF CONTENTS

Chapter		Page
1.0	Introduction	1
2.0	Z80-CPU Architecture	3
3.0	Z80-CPU Pin Description	7
4.0	CPU Timing	11
5.0	Z80-CPU Instruction Set	19
6.0	Flags	39
7.0	Summary of OP Codes and Execution Times	43
8.0	Interrupt Response	55
9.0	Hardware Implementation Examples	59
10.0	Software Implementation Examples	63
11.0	Electrical Specifications	69
12.0	Z80-CPU Instruction Set Summary	73

1.0 INTRODUCTION

The term "microcomputer" has been used to describe virtually every type of small computing device designed within the last few years. This term has been applied to everything from simple "microprogrammed" controllers constructed out of TTL MSI up to low end minicomputers with a portion of the CPU constructed out of TTL LSI "bit slices." However, the major impact of the LSI technology within the last few years has been with MOS LSI. With this technology, it is possible to fabricate complete and very powerful computer systems with only a few MOS LSI components.

The Zilog Z-80 family of components is a significant advancement in the state-of-the-art of microcomputers. These components can be configured with any type of standard semiconductor memory to generate computer systems with an extremely wide range of capabilities. For example, as few as two LSI circuits and three standard TTL MSI packages can be combined to form a simple controller. With additional memory and I/O devices a computer can be constructed with capabilities that only a minicomputer could previously deliver. This wide range of computational power allows standard modules to be constructed by a user that can satisfy the requirements of an extremely wide range of applications.

The major reason for MOS LSI domination of the microcomputer market is the low cost of these few LSI components. For example, MOS LSI microcomputers have already replaced TTL logic in such applications as terminal controllers, peripheral device controllers, traffic signal controllers, point of sale terminals, intelligent terminals and test systems. In fact the MOS LSI microcomputer is finding its way into almost every product that now uses electronics and it is even replacing many mechanical systems such as weight scales and automobile controls.

The MOS LSI microcomputer market is already well established and new products using them are being developed at an extraordinary rate. The Zilog Z-80 component set has been designed to fit into this market through the following factors:

1. The Z-80 is fully software compatible with the popular 8080A CPU offered from several sources. Existing designs can be easily converted to include the Z-80 as a superior alternative.
2. The Z-80 component set is superior in both software and hardware capabilities to any other microcomputer system on the market. These capabilities provide the user with significantly lower hardware and software development costs while also allowing him to offer additional features in his system.
3. For increased throughput the Z80A operating at a 4 MHz clock rate offers the user significant speed advantages over competitive products.
4. A complete product line including full software support with strong emphasis on high level languages and a disk-based development system with advanced real-time debug capabilities is offered to enable the user to easily develop new products.

Microcomputer systems are extremely simple to construct using Z-80 components. Any such system consists of three parts:

1. CPU (Central Processing Unit)
2. Memory
3. Interface Circuits to peripheral devices

The CPU is the heart of the system. Its function is to obtain instructions from the memory and perform the desired operations. The memory is used to contain instructions and in most cases data that is to be processed. For example, a typical instruction sequence may be to read data from a specific peripheral device, store it in a location in memory, check the parity and write it out to another peripheral device. Note that the Zilog component set includes the CPU and various general purpose I/O device controllers, while a wide range of memory devices may be used from any source. Thus, all required components can be connected together in a very simple manner with virtually no other external logic. The user's effort then becomes primarily one of software development. That is, the user can concentrate on describing his problem and translating it into a series of instructions that can be loaded into the microcomputer memory. Zilog is dedicated to making this step of software generation as simple as possible. A good example of this is our

assembly language in which a single mnemonic is used to represent every instruction that the CPU can perform. This language is self documenting in such a way that from the mnemonic the user can understand exactly what the instruction is doing without constantly checking back to a complex cross listing.

2.0 Z-80 CPU ARCHITECTURE

A block diagram of the internal architecture of the Z-80 CPU is shown in figure 2.0-1. The diagram shows all of the major elements in the CPU and it should be referred to throughout the following description.

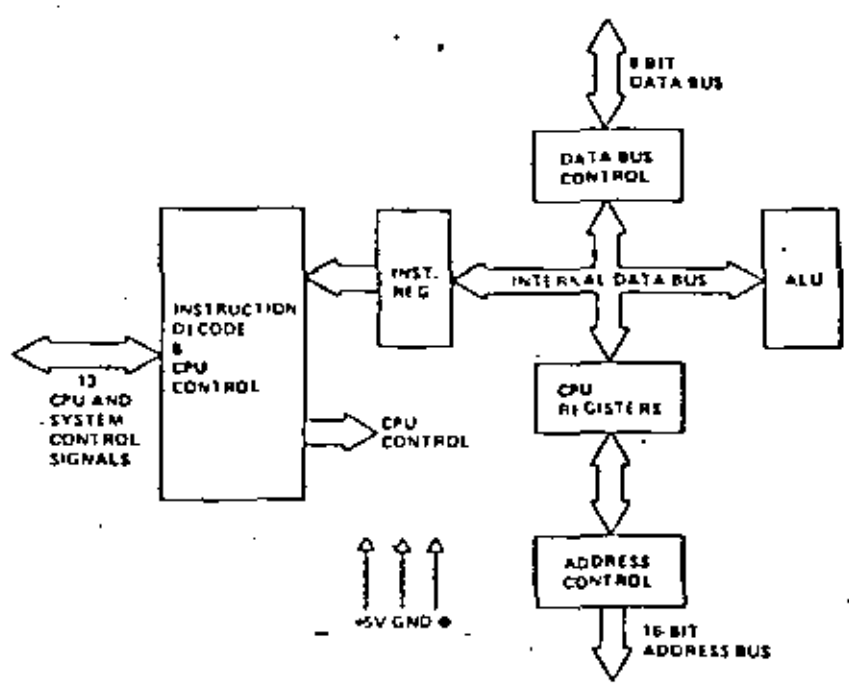

Z-80 CPU BLOCK DIAGRAM
FIGURE 2.0-1

2.1 CPU REGISTERS

The Z-80 CPU contains 208 bits of R/W memory that are accessible to the programmer. Figure 2.0-2 illustrates how this memory is configured into eighteen 8-bit registers and four 16-bit registers. All Z-80 registers are implemented using static RAM. The registers include two sets of six general purpose registers that may be used individually as 8-bit registers or in pairs as 16-bit registers. There are also two sets of accumulator and flag registers.

Special Purpose Registers

1. Program Counter (PC). The program counter holds the 16-bit address of the current instruction being fetched from memory. The PC is automatically incremented after its contents have been transferred to the address lines. When a program jump occurs the new value is automatically placed in the PC, overriding the incrementer.
2. Stack Pointer (SP). The stack pointer holds the 16-bit address of the current top of a stack located anywhere in external system RAM memory. The external stack memory is organized as a last-in first-out (LIFO) file. Data can be pushed onto the stack from specific CPU registers or popped off of the stack into specific CPU registers through the execution of PUSH and POP instructions. The data popped from the stack is always the last data pushed onto it. The stack allows simple implementation of multiple level interrupts, unlimited subroutine nesting and simplification of many types of data manipulation.

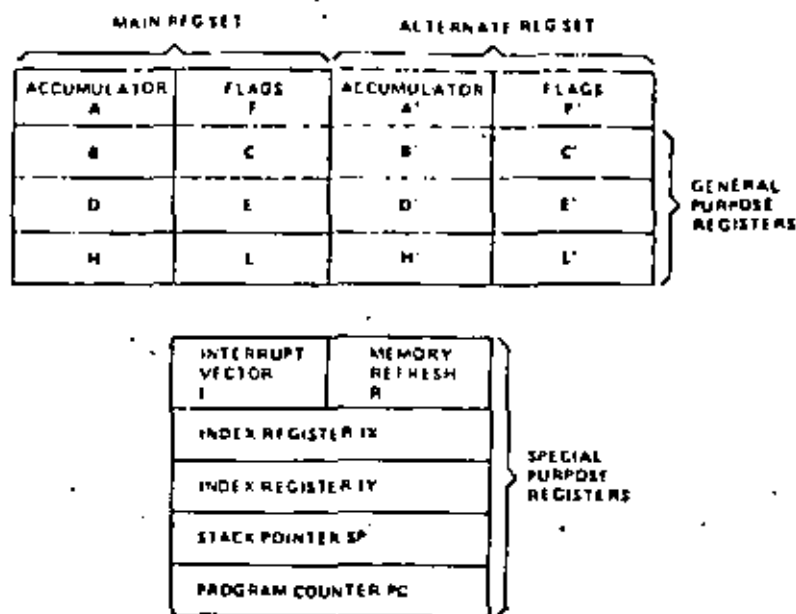

Z-80 CPU REGISTER CONFIGURATION
FIGURE 2.0-2

3. **Two Index Registers (IX & IY).** The two independent index registers hold a 16-bit base address that is used in indexed addressing modes. In this mode, an index register is used as a base to point to a region in memory from which data is to be stored or retrieved. An additional byte is included in indexed instructions to specify a displacement from this base. This displacement is specified as a two's complement signed integer. This mode of addressing greatly simplifies many types of programs, especially where tables of data are used.
4. **Interrupt Page Address Register (I).** The Z-80 CPU can be operated in a mode where an indirect call to any memory location can be achieved in response to an interrupt. The I Register is used for this purpose to store the high order 8-bits of the indirect address while the interrupting device provides the lower 8-bits of the address. This feature allows interrupt routines to be dynamically located anywhere in memory with absolute minimal access time to the routine.
5. **Memory Refresh Register (R).** The Z-80 CPU contains a memory refresh counter to enable dynamic memories to be used with the same ease as static memories. Seven bits of this 8 bit register are automatically incremented after each instruction fetch. The eighth bit will remain as programmed as the result of an LD R, A instruction. The data in the refresh counter is sent out on the lower portion of the address bus along with a refresh control signal while the CPU is decoding and executing the fetched instruction. This mode of refresh is totally transparent to the programmer and does not slow down the CPU operation. The programmer can load the R register for testing purposes, but this register is normally not used by the programmer. During refresh, the contents of the I register are placed on the upper 8 bits of the address bus.

Accumulator and Flag Registers

The CPU includes two independent 8-bit accumulators and associated 8-bit flag registers. The accumulator holds the results of 8-bit arithmetic or logical operations while the flag register indicates specific conditions for 8 or 16-bit operations, such as indicating whether or not the result of an operation is equal to zero. The programmer selects the accumulator and flag pair that he wishes to work with with a single exchange instruction so that he may easily work with either pair.

General Purpose Registers

There are two matched sets of general purpose registers, each set containing six 8-bit registers that may be used individually as 8-bit registers or as 16-bit register pairs by the programmer. One set is called BC, DE and HL while the complementary set is called BC', DE' and HL'. At any one time the programmer can select either set of registers to work with through a single exchange command for the entire set. In systems where fast interrupt response is required, one set of general purpose registers and an accumulator/flag register may be reserved for handling this very fast routine. Only a simple exchange commands need be executed to go between the routines. This greatly reduces interrupt service time by eliminating the requirement for saving and retrieving register contents in the external stack during interrupt or subroutine processing. These general purpose registers are used for a wide range of applications by the programmer. They also simplify programming, especially in ROM based systems where little external read/write memory is available.

2.2 ARITHMETIC & LOGIC UNIT (ALU)

The 8-bit arithmetic and logical instructions of the CPU are executed in the ALU. Internally the ALU communicates with the registers and the external data bus on the internal data bus. The type of functions performed by the ALU include:

Add	Left or right shifts or rotates (arithmetic and logical)
Subtract	Increment
Logical AND	Decrement
Logical OR	Set bit
Logical Exclusive OR	Reset bit
Compare	Test bit

2.3 INSTRUCTION REGISTER AND CPU CONTROL

As each instruction is fetched from memory, it is placed in the instruction register and decoded. The control sections performs this function and then generates and supplies all of the control signals necessary to read or write data from or to the registers, control the ALU and provide all required external control signals.

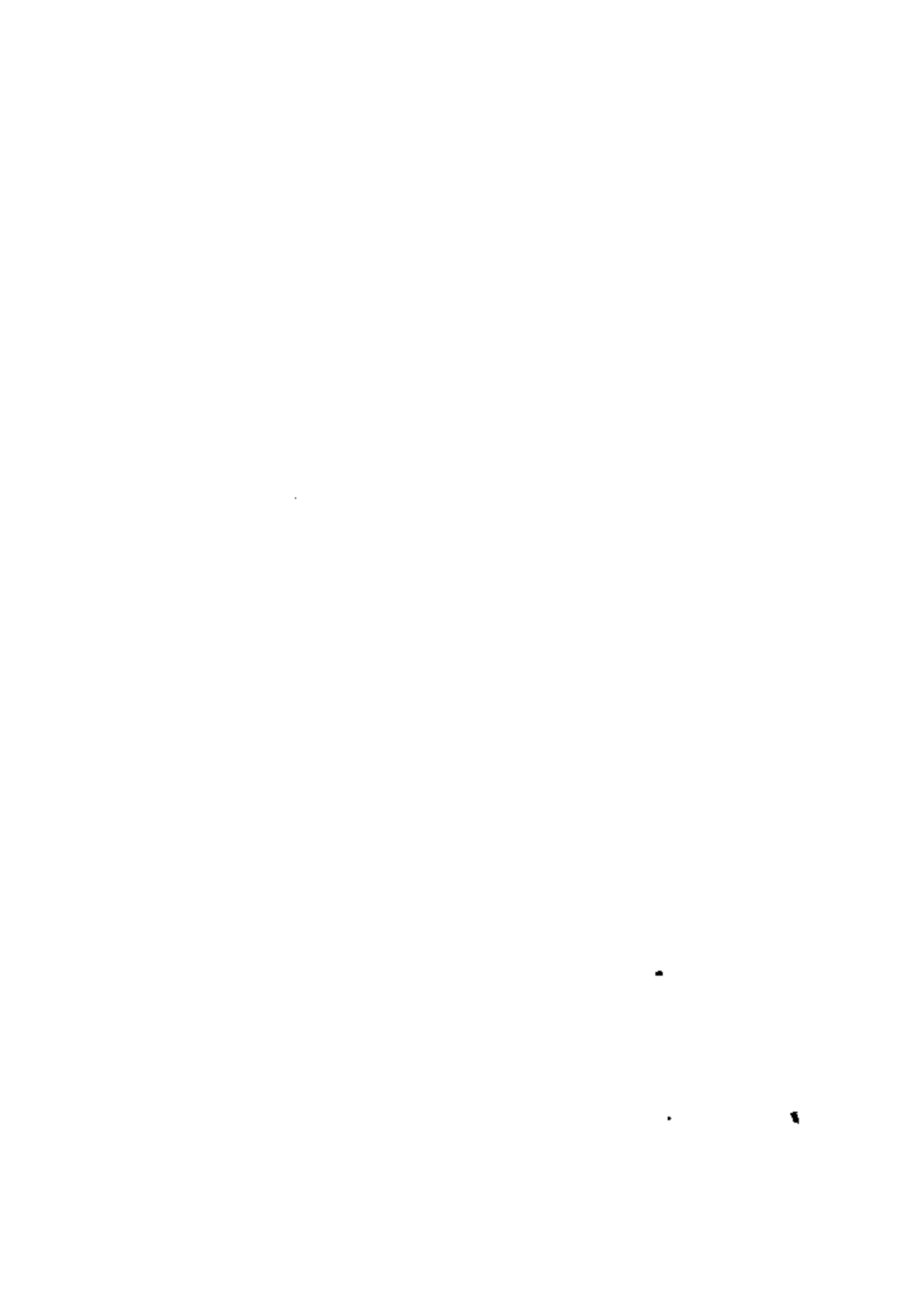

3.0 Z-80 CPU PIN DESCRIPTION

The Z-80 CPU is packaged in an industry standard 40 pin Dual In-Line Package. The I/O pins are shown in figure 3.0-1 and the function of each is described below.

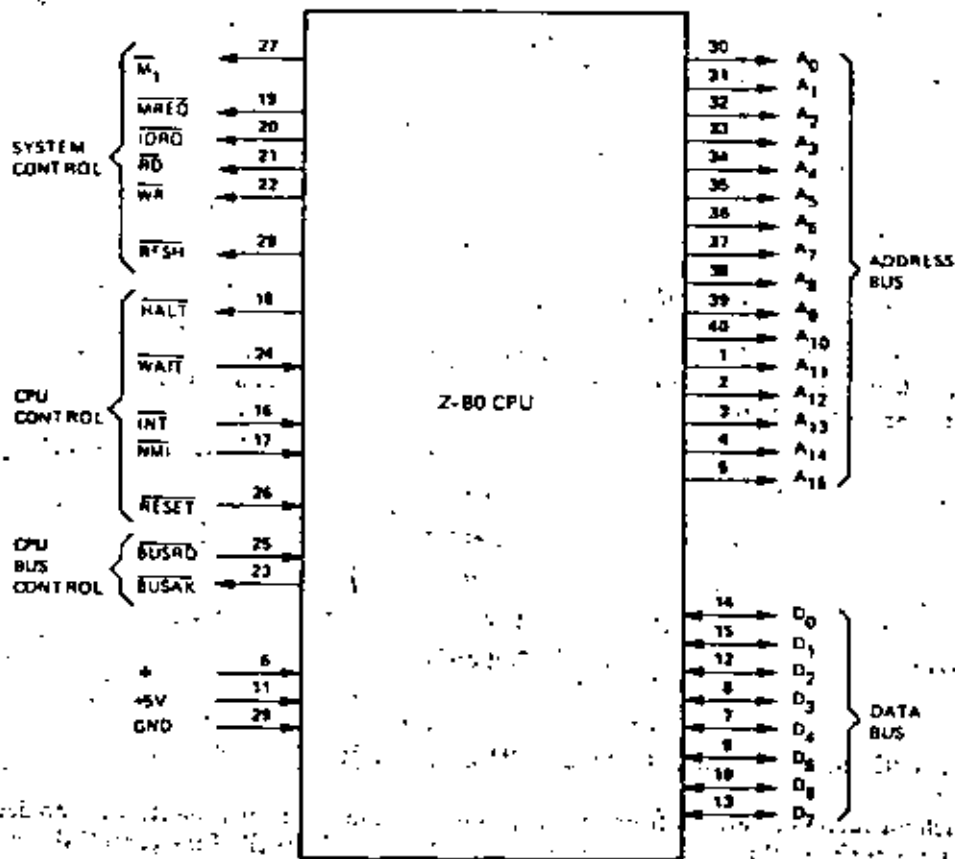

Z-80 PIN CONFIGURATION
FIGURE 3.0-1

A_0 - A_{15}
(Address Bus)

Tri-state output, active high. A_0 - A_{15} constitute a 16-bit address bus. The address bus provides the address for memory (up to 64K bytes) data exchanges and for I/O device data exchanges. I/O addressing uses the 8 lower address bits to allow the user to directly select up to 256 input or 256 output ports. A_0 is the least significant address bit. During refresh time, the lower 7 bits contain a valid refresh address.

D_0 - D_7
(Data Bus)

Tri-state input/output, active high. D_0 - D_7 constitute an 8-bit bidirectional data bus. The data bus is used for data exchanges with memory and I/O devices.

\overline{M}_1
(Machine Cycle one)

Output, active low. \overline{M}_1 indicates that the current machine cycle is the OP code fetch cycle of an instruction execution. Note that during execution of 2-byte op-codes, \overline{M}_1 is generated as each op code byte is fetched. These two byte op-codes always begin with CBH, DDH, EDH or FDH. \overline{M}_1 also occurs with \overline{IORQ} to indicate an interrupt acknowledge cycle.

\overline{MREQ}
(Memory Request)

Tri-state output, active low. The memory request signal indicates that the address bus holds a valid address for a memory read or memory write operation.

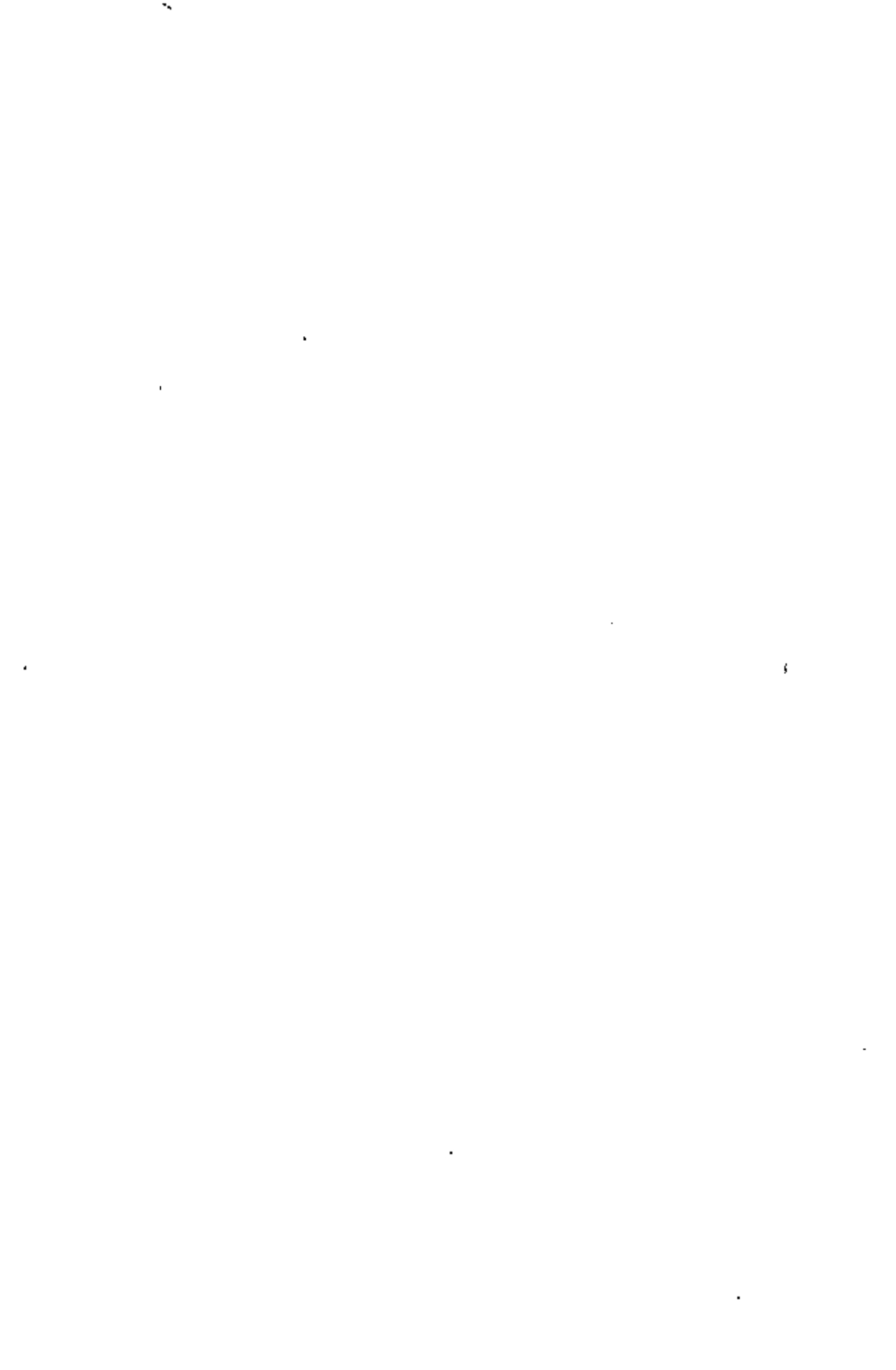

$\overline{\text{IORQ}}$ (Input/Output Request)	Tri-state output, active low. The $\overline{\text{IORQ}}$ signal indicates that the lower half of the address bus holds a valid I/O address for a I/O read or write operation. An $\overline{\text{IORQ}}$ signal is also generated with an $\overline{\text{MI}}$ signal when an interrupt is being acknowledged to indicate that an interrupt response vector can be placed on the data bus. Interrupt Acknowledge operations occur during M_1 time while I/O operations never occur during M_2 time.
$\overline{\text{RD}}$ (Memory Read)	Tri-state output, active low. $\overline{\text{RD}}$ indicates that the CPU wants to read data from memory or an I/O device. The addressed I/O device or memory should use this signal to gate data onto the CPU data bus.
$\overline{\text{WR}}$ (Memory Write)	Tri-state output, active low. $\overline{\text{WR}}$ indicates that the CPU data bus holds valid data to be stored in the addressed memory or I/O device.
$\overline{\text{RFSH}}$ (Refresh)	Output, active low. $\overline{\text{RFSH}}$ indicates that the lower 7 bits of the address bus contain a refresh address for dynamic memories and the current $\overline{\text{MREQ}}$ signal should be used to do a refresh read to all dynamic memories.
$\overline{\text{HALT}}$ (Halt state)	Output, active low. $\overline{\text{HALT}}$ indicates that the CPU has executed a HALT software instruction and is awaiting either a non maskable or a maskable interrupt (with the mask enabled) before operation can resume. While halted, the CPU executes NOP's to maintain memory refresh activity.
$\overline{\text{WAIT}}$ (Wait)	Input, active low. $\overline{\text{WAIT}}$ indicates to the Z-80 CPU that the addressed memory or I/O devices are not ready for a data transfer. The CPU continues to enter wait states for as long as this signal is active. This signal allows memory or I/O devices of any speed to be synchronized to the CPU.
$\overline{\text{INT}}$ (Interrupt Request)	Input, active low. The Interrupt Request signal is generated by I/O devices. A request will be honored at the end of the current instruction if the internal software controlled interrupt enable flip-flop (IFF) is enabled and if the $\overline{\text{BUSRQ}}$ signal is not active. When the CPU accepts the interrupt, an acknowledge signal ($\overline{\text{IORQ}}$ during M_1 time) is sent out at the beginning of the next instruction cycle. The CPU can respond to an interrupt in three different modes that are described in detail in section 5.4 (CPU Control Instructions).
$\overline{\text{NMI}}$ (Non Maskable Interrupt)	Input, negative edge triggered. The non maskable interrupt request line has a higher priority than $\overline{\text{INT}}$ and is always recognized at the end of the current instruction, independent of the status of the interrupt enable flip-flop. $\overline{\text{NMI}}$ automatically forces the Z-80 CPU to restart to location 0066H. The program counter is automatically saved in the external stack so that the user can return to the program that was interrupted. Note that continuous $\overline{\text{WAIT}}$ cycles can prevent the current instruction from ending, and that a $\overline{\text{BUSRQ}}$ will override a $\overline{\text{NMI}}$.



RESET

Input, active low. **RESET** forces the program counter to zero and initializes the CPU. The CPU initialization includes:

- 1) Disable the interrupt enable flip-flop
- 2) Set Register I = 00_H
- 3) Set Register R = 00_H
- 4) Set Interrupt Mode 0

During reset time, the address bus and data bus go to a high impedance state and all control output signals go to the inactive state.

BUSRQ
(Bus Request)

Input, active low. The bus request signal is used to request the CPU address bus, data bus and tri-state output control signals to go to a high impedance state so that other devices can control these buses. When **BUSRQ** is activated, the CPU will set these buses to a high impedance state as soon as the current CPU machine cycle is terminated.

BUSAK
(Bus Acknowledge)

Output, active low. Bus acknowledge is used to indicate to the requesting device that the CPU address bus, data bus and tri-state control bus signals have been set to their high impedance state and the external device can now control these signals.

Single phase TTL level clock which requires only a 330 ohm pull-up resistor to +5 volts to meet all clock requirements.



4.0 CPU TIMING

The Z-80 CPU executes instructions by stepping through a very precise set of a few basic operations. These include:

- Memory read or write
- I/O device read or write
- Interrupt acknowledge

All instructions are merely a series of these basic operations. Each of these basic operations can take from three to six clock periods to complete or they can be lengthened to synchronize the CPU to the speed of external devices. The basic clock periods are referred to as T cycles and the basic operations are referred to as M (for machine) cycles. Figure 4.0-0 illustrates how a typical instruction will be merely a series of specific M and T cycles. Notice that this instruction consists of three machine cycles (M1, M2 and M3). The first machine cycle of any instruction is a fetch cycle which is four, five or six T cycles long (unless lengthened by the wait signal which will be fully described in the next section). The fetch cycle (M1) is used to fetch the OP code of the next instruction to be executed. Subsequent machine cycles move data between the CPU and memory or I/O devices and they may have anywhere from three to five T cycles (again they may be lengthened by wait states to synchronize the external devices to the CPU). The following paragraphs describe the timing which occurs within any of the basic machine cycles. In section 7, the exact timing for each instruction is specified.

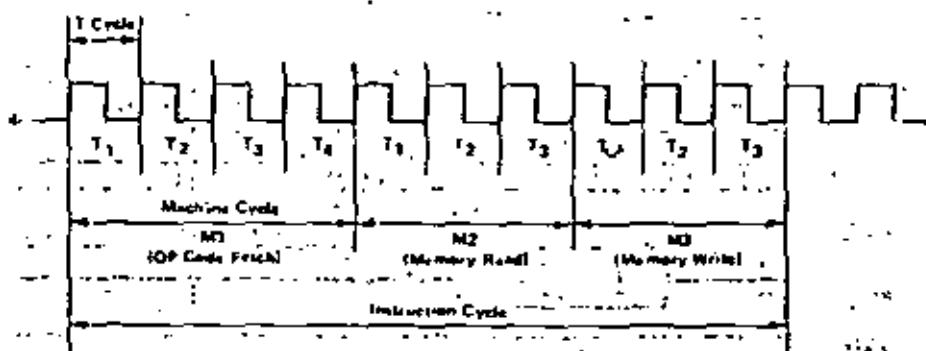

BASIC CPU TIMING EXAMPLE
FIGURE 4.0-0

All CPU timing can be broken down into a few very simple timing diagrams as shown in figure 4.0-1 through 4.0-7. These diagrams show the following basic operations with and without wait states (wait states are added to synchronize the CPU to slow memory or I/O devices).

- 4.0-1. Instruction OP code fetch (M1 cycle)
- 4.0-2. Memory data read or write cycles
- 4.0-3. I/O read or write cycles
- 4.0-4. Bus Request/Acknowledge Cycle
- 4.0-5. Interrupt Request/Acknowledge Cycle
- 4.0-6. Non maskable Interrupt Request/Acknowledge Cycle
- 4.0-7. Exit from a HALT instruction



INSTRUCTION FETCH

Figure 4.0-1 shows the timing during an M1 cycle (OP code fetch). Notice that the PC is placed on the address bus at the beginning of the M1 cycle. One half clock time later the \overline{MREQ} signal goes active. At this time the address to the memory has had time to stabilize so that the falling edge of \overline{MREQ} can be used directly as a chip enable clock to dynamic memories. The \overline{RD} line also goes active to indicate that the memory read data should be enabled onto the CPU data bus. The CPU samples the data from the memory on the data bus with the rising edge of the clock of state T3 and this same edge is used by the CPU to turn off the \overline{RD} and \overline{MREQ} signals. Thus the data has already been sampled by the CPU before the \overline{RD} signal becomes inactive. Clock state T3 and T4 of a fetch cycle are used to refresh dynamic memories. (The CPU uses this time to decode and execute the fetched instruction so that no other operation could be performed at this time). During T3 and T4 the lower 7 bits of the address bus contain a memory refresh address and the \overline{RFSH} signal becomes active to indicate that a refresh read of all dynamic memories should be accomplished. Notice that a \overline{RD} signal is not generated during refresh time to prevent data from different memory segments from being gated onto the data bus. The \overline{MREQ} signal during refresh time should be used to perform a refresh read of all memory elements. The refresh signal can not be used by itself since the refresh address is only guaranteed to be stable during \overline{MREQ} time.

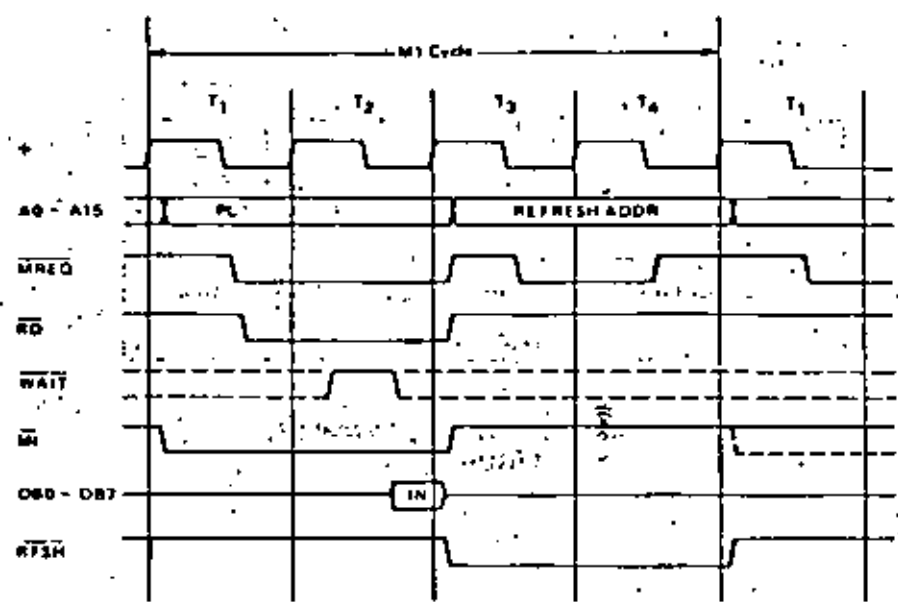

INSTRUCTION OF CODE FETCH
FIGURE 4.0-1

Figure 4.0-1A illustrates how the fetch cycle is delayed if the memory activates the \overline{WAIT} line. During T2 and every subsequent Tw, the CPU samples the \overline{WAIT} line with the falling edge of Φ . If the \overline{WAIT} line is active at this time, another wait state will be entered during the following cycle. Using this technique the read cycle can be lengthened to match the access time of any type of memory device.

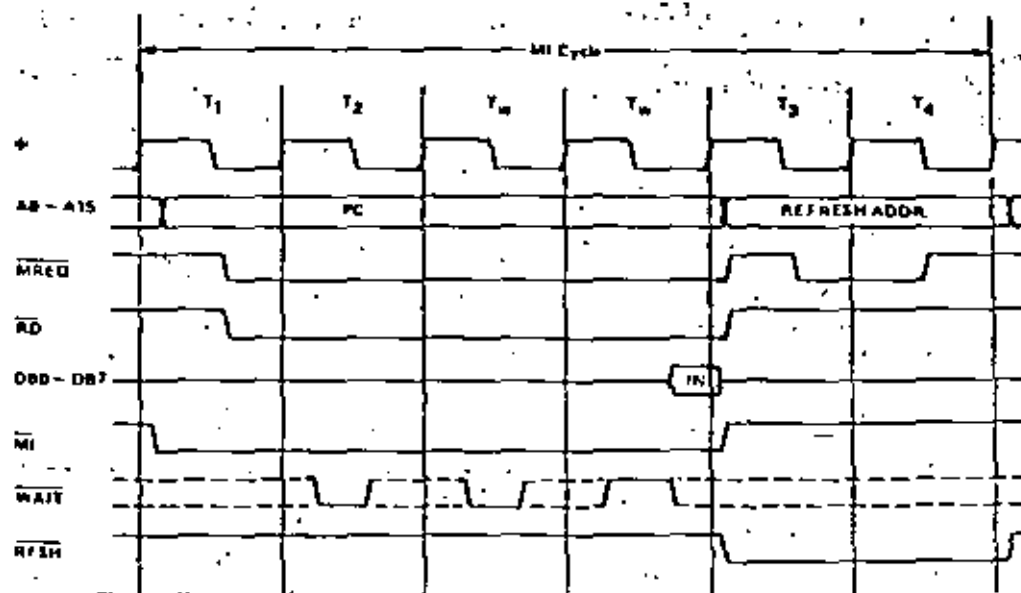

INSTRUCTION OP CODE FETCH WITH WAIT STATES.
FIGURE 4.0-1A

MEMORY READ OR WRITE

Figure 4.0-2 illustrates the timing of memory read or write cycles other than an OP code fetch (MI cycle). These cycles are generally three clock periods long unless wait states are requested by the memory via the WAIT signal. The MREQ signal and the RD signal are used the same as in the fetch cycle. In the case of a memory write cycle, the MREQ also becomes active when the address bus is stable so that it can be used directly as a chip enable for dynamic memories. The WR line is active when data on the data bus is stable so that it can be used directly as a R/W pulse to virtually any type of semiconductor memory. Furthermore the WR signal goes inactive one half T state before the address and data bus contents are changed so that the overlap requirements for virtually any type of semiconductor memory type will be met.

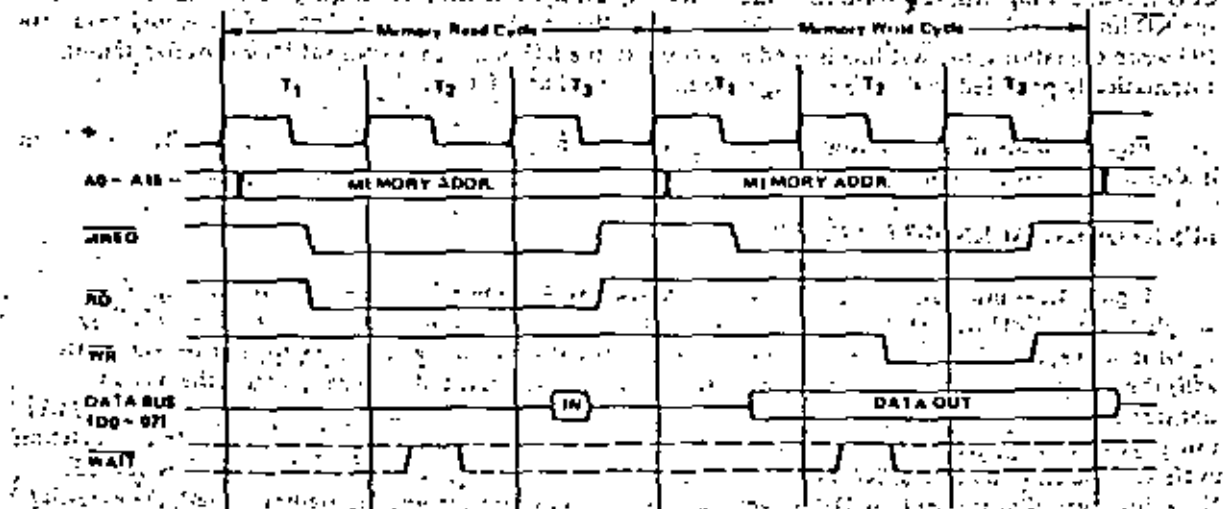

MEMORY READ OR WRITE CYCLES.
FIGURE 4.0-2

Figure 4.0-2A illustrates how a WAIT request signal will lengthen any memory read or write operation. This operation is identical to that previously described for a fetch cycle. Notice in this figure that a separate read and a separate write cycle are shown in the same figure although read and write cycles can never occur simultaneously.

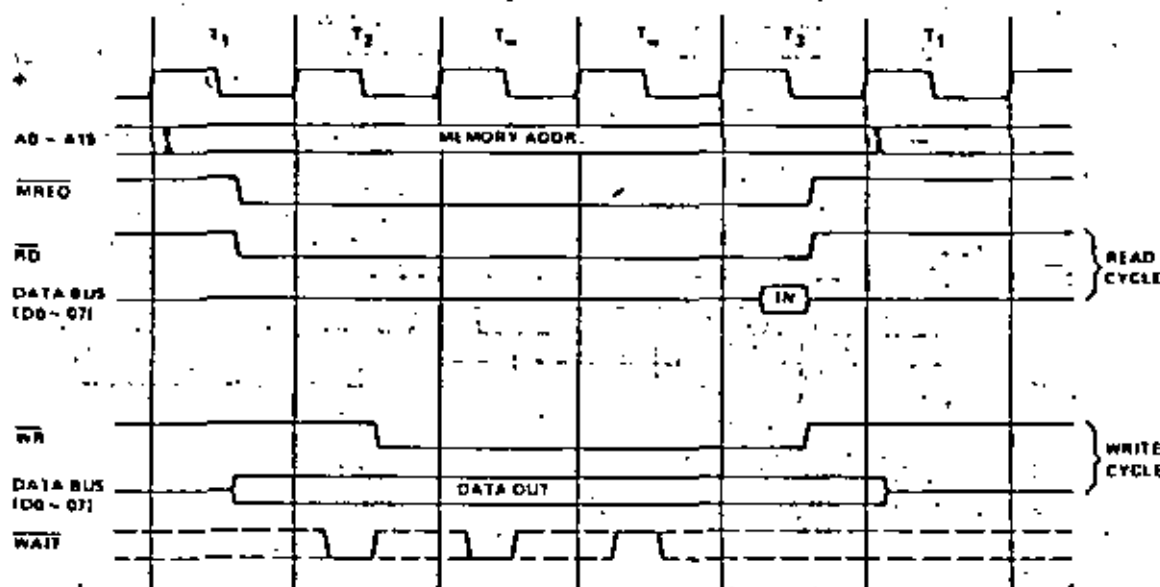

MEMORY READ OR WRITE CYCLES WITH WAIT STATES

FIGURE 4.0-2A

INPUT OR OUTPUT CYCLES

Figure 4.0-3 illustrates an I/O read or I/O write operation. Notice that during I/O operations a single wait state is automatically inserted. The reason for this is that during I/O operations, the time from when the IORQ signal goes active until the CPU must sample the WAIT line is very short and without this extra state sufficient time does not exist for an I/O port to decode its address and activate the WAIT line if a wait is required. Also, without this wait state it is difficult to design MOS I/O devices that can operate at full CPU speed. During this wait state time the WAIT request signal is sampled. During a read I/O operation, the RD line is used to enable the addressed port onto the data bus just as in the case of a memory read. For I/O write operations, the WR line is used as a clock to the I/O port, again with sufficient overlap timing automatically provided so that the rising edge may be used as a data clock.

Figure 4.0-3A illustrates how additional wait states may be added with the WAIT line. The operation is identical to that previously described.

BUS REQUEST/ACKNOWLEDGE CYCLE

Figure 4.0-4 illustrates the timing for a Bus Request/Acknowledge cycle. The BUSRQ signal is sampled by the CPU with the rising edge of the last clock period of any machine cycle. If the BUSRQ signal is active, the CPU will set its address, data and tri-state control signals to the high impedance state with the rising edge of the next clock pulse. At that time any external device can control the buses to transfer data between memory and I/O devices. (This is generally known as Direct Memory Access [DMA] using cycle stealing). The maximum time for the CPU to respond to a bus request is the length of a machine cycle and the external controller can maintain control of the bus for as many clock cycles as is desired. Note, however, that if very long DMA cycles are used, and dynamic memories are being used, the external controller must also perform the refresh function. This situation only occurs if very large blocks of data are transferred under DMA control. Also note that during a bus request cycle, the CPU cannot be interrupted by either a NMI or an INT signal.



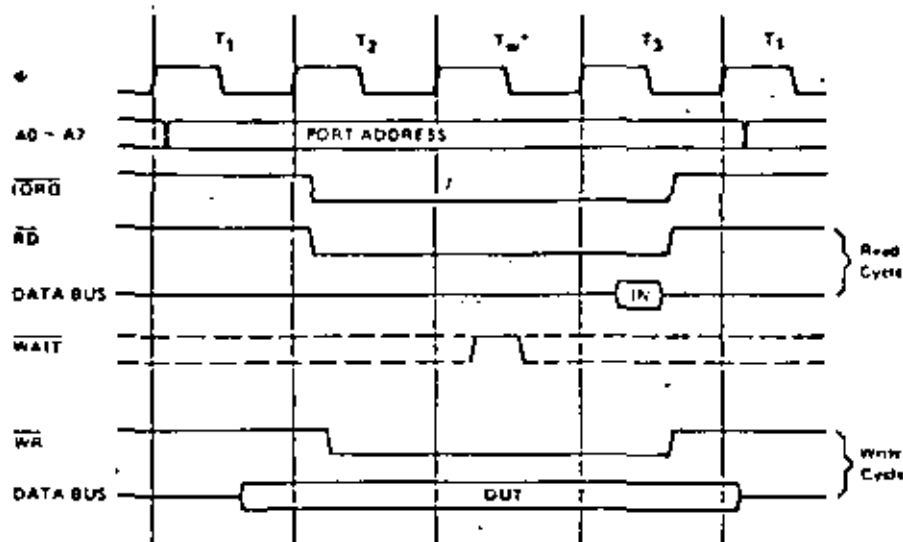

INPUT OR OUTPUT CYCLES
FIGURE 4.0.3

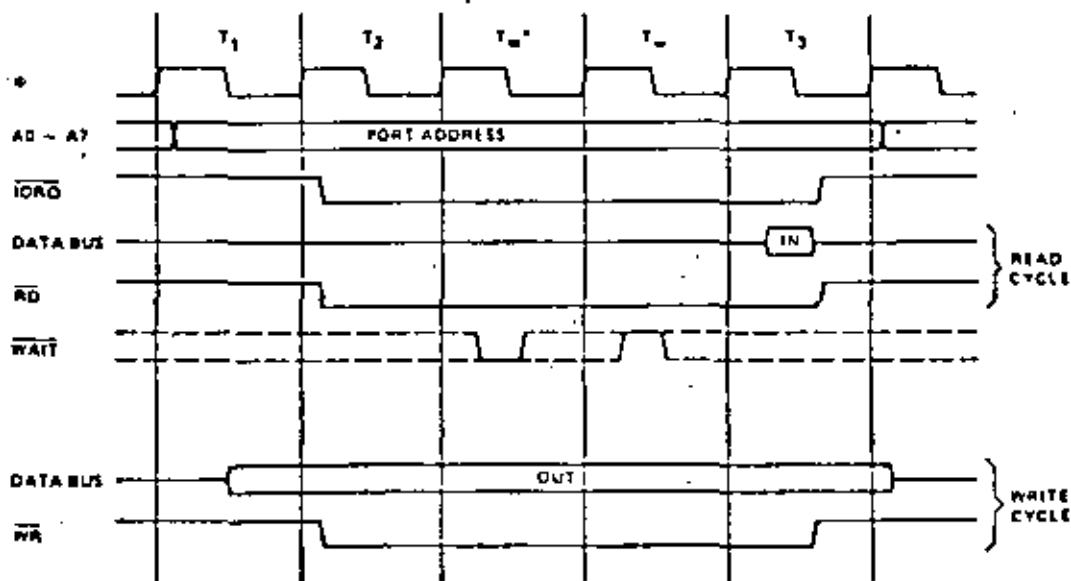

INPUT OR OUTPUT CYCLES WITH WAIT STATES
FIGURE 4.0.3A

• Automatically inserted WAIT state

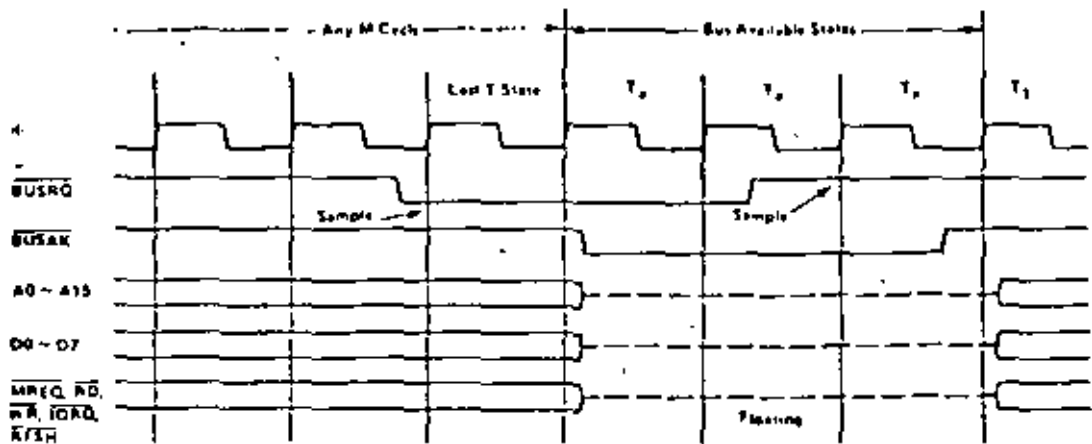

BUS REQUEST/ACKNOWLEDGE CYCLE
FIGURE 4.0-4

INTERRUPT REQUEST/ACKNOWLEDGE CYCLE

Figure 4.0.5 illustrates the timing associated with an interrupt cycle. The interrupt signal (\overline{INT}) is sampled by the CPU with the rising edge of the last clock at the end of any instruction. The signal will not be accepted if the internal CPU software controlled interrupt enable flip-flop is not set or if the \overline{BUSRQ} signal is active. When the signal is accepted a special M1 cycle is generated. During this special M1 cycle the \overline{IORQ} signal becomes active (instead of the normal MREQ) to indicate that the interrupting device can place an 8-bit vector on the data bus. Notice that two wait states are automatically added to this cycle. These states are added so that a ripple priority interrupt scheme can be easily implemented. The two wait states allow sufficient time for the ripple signals to stabilize and identify which I/O device must insert the response vector. Refer to section 8.0 for details on how the interrupt response vector is utilized by the CPU.

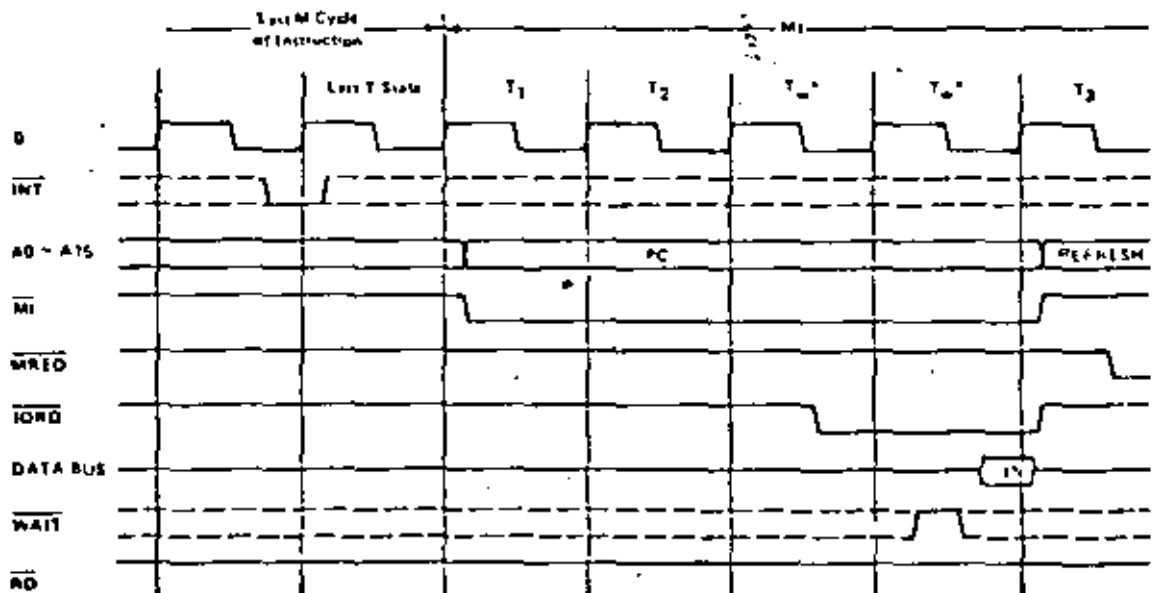

INTERRUPT REQUEST/ACKNOWLEDGE CYCLE
FIGURE 4.0-5

Figures 4.0-5A and 4.0-5B illustrate how a programmable counter can be used to extend interrupt acknowledge time. (Configured as shown to add one wait state)

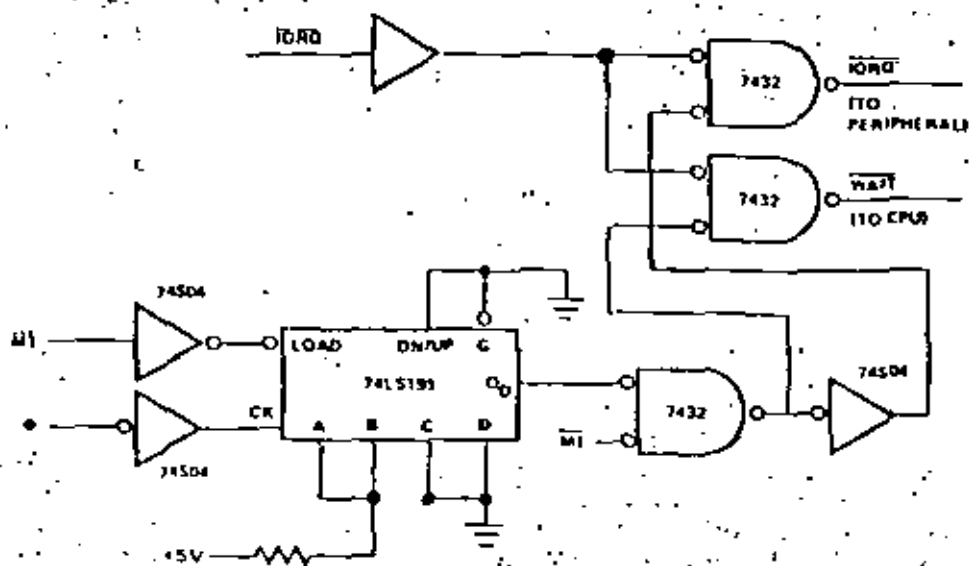

EXTENDING INTERRUPT ACKNOWLEDGE TIME WITH WAIT STATE
FIGURE 4.0-5A

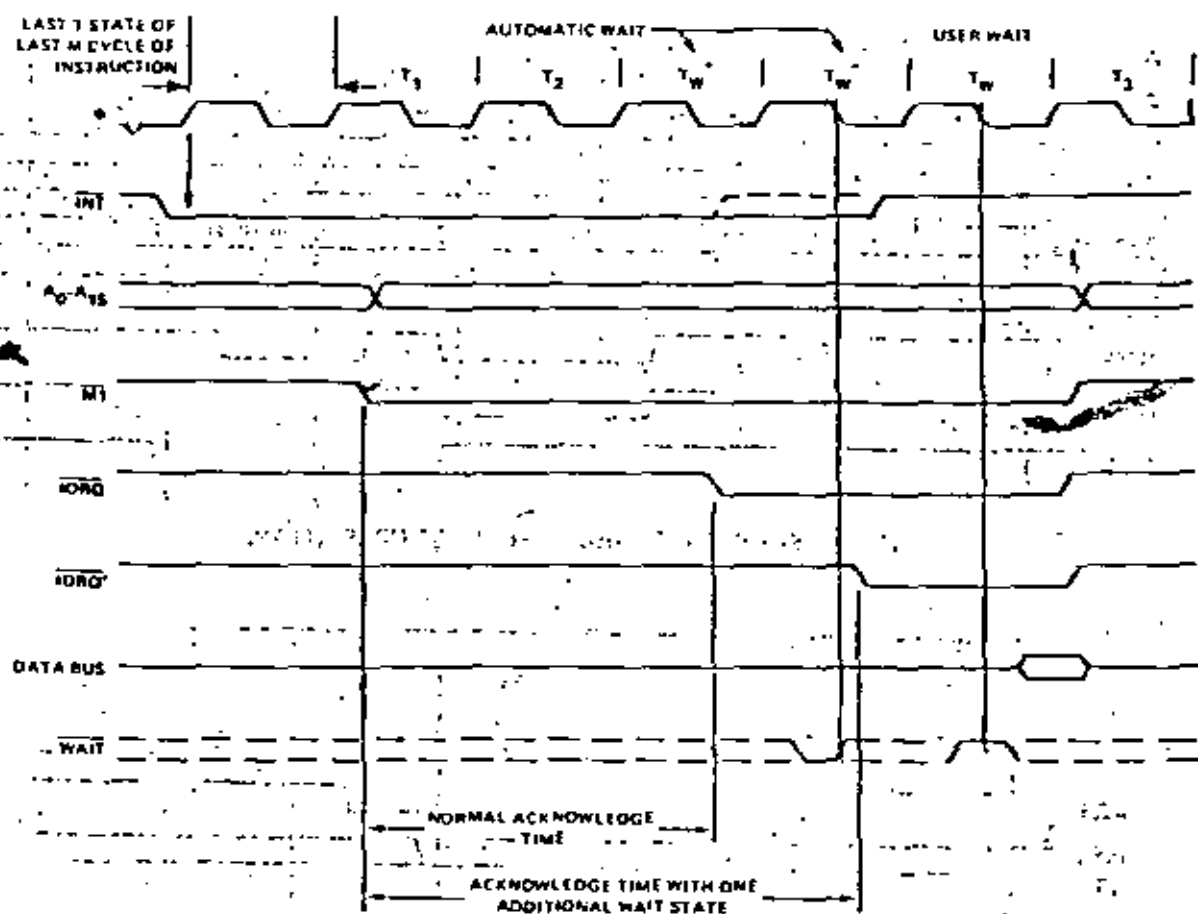

REQUEST/ACKNOWLEDGE CYCLE WITH ONE ADDITIONAL WAIT STATE
FIGURE 4.0-5B

NON MASKABLE INTERRUPT RESPONSE

Figure 4.0-6 illustrates the request/acknowledge cycle for the non maskable interrupt. This signal is sampled at the same time as the interrupt line, but this line has priority over the normal interrupt and it can not be disabled under software control. Its usual function is to provide immediate response to important signals such as an impending power failure. The CPU response to a non maskable interrupt is similar to a normal memory read operation. The only difference being that the content of the data bus is ignored while the processor automatically stores the PC in the external stack and jumps to location 0066_H. The service routine for the non maskable interrupt must begin at this location if this interrupt is used.

HALT EXIT

Whenever a software halt instruction is executed the CPU begins executing NOP's until an interrupt is received (either a non maskable or a maskable interrupt while the interrupt flip flop is enabled). The two interrupt lines are sampled with the rising clock edge during each T4 state as shown in figure 4.0-7. If a non maskable interrupt has been received or a maskable interrupt has been received and the interrupt enable flip-flop is set, then the halt state will be exited on the next rising clock edge. The following cycle will then be an interrupt acknowledge cycle corresponding to the type of interrupt that was received. If both are received at this time, then the non maskable one will be acknowledged since it has highest priority. The purpose of executing NOP instructions while in the halt state is to keep the memory refresh signals active. Each cycle in the halt state is a normal M1 (fetch) cycle except that the data received from the memory is ignored and a NOP instruction is forced internally to the CPU. The halt acknowledge signal is active during this time to indicate that the processor is in the halt state.

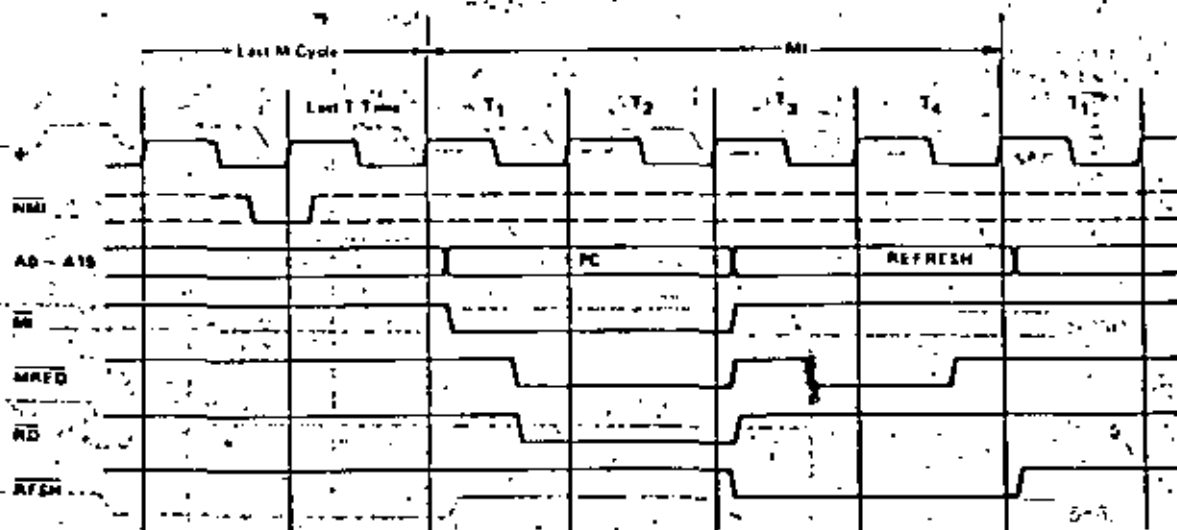

NON MASKABLE INTERRUPT REQUEST OPERATION

FIGURE 4.0-6

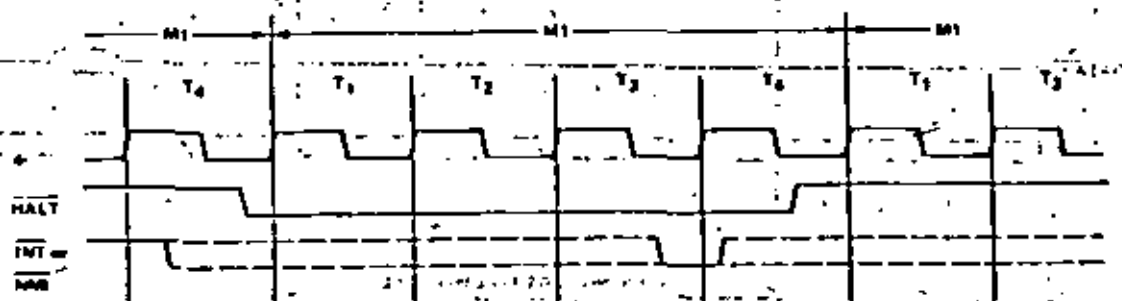

HALT INSTRUCTION
IS RECEIVED
DURING INT
MEMORY CYCLE

HALT EXIT

FIGURE 4.0-7

5.0 Z-80 CPU INSTRUCTION SET

The Z-80 CPU can execute 158 different instruction types including all 78 of the 8080A CPU. The instructions can be broken down into the following major groups:

- Load and Exchange
- Block Transfer and Search
- Arithmetic and Logical
- Rotate and Shift
- Bit Manipulation (set, reset, test)
- Jump, Call and Return
- Input/Output
- Basic CPU Control

5.1 INTRODUCTION TO INSTRUCTION TYPES

The load instructions move data internally between CPU registers or between CPU registers and external memory. All of these instructions must specify a source location from which the data is to be moved and a destination location. The source location is not altered by a load instruction. Examples of load group instructions include moves between any of the general purpose registers such as move the data to Register B from Register C. This group also includes load immediate to any CPU register or to any external memory location. Other types of load instructions allow transfer between CPU registers and memory locations. The exchange instructions can trade the contents of two registers.

A unique set of block transfer instructions is provided in the Z-80. With a single instruction a block of memory of any size can be moved to any other location in memory. This set of block moves is extremely valuable when large strings of data must be processed. The Z-80 block search instructions are also valuable for this type of processing. With a single instruction, a block of external memory of any desired length can be searched for any 8-bit character. Once the character is found or the end of the block is reached, the instruction automatically terminates. Both the block transfer and the block search instructions can be interrupted during their execution so as to not occupy the CPU for long periods of time.

The arithmetic and logical instructions operate on data stored in the accumulator and other general purpose CPU registers or external memory locations. The results of the operations are placed in the accumulator and the appropriate flags are set according to the result of the operation. An example of an arithmetic operation is adding the accumulator to the contents of an external memory location. The results of the addition are placed in the accumulator. This group also includes 16-bit addition and subtraction between 16-bit CPU registers.

The rotate and shift group allows any register or any memory location to be rotated right or left with or without carry either arithmetic or logical. Also, a digit in the accumulator can be rotated right or left with two digits in any memory location.

The bit manipulation instructions allow any bit in the accumulator, any general purpose register or any external memory location to be set, reset or tested with a single instruction. For example, the most significant bit of register H can be reset. This group is especially useful in control applications and for controlling software flags in general purpose programming.

The jump, call and return instructions are used to transfer between various locations in the user's program. This group uses several different techniques for obtaining the new program counter address from specific external memory locations. A unique type of call is the restart instruction. This instruction actually contains the new address as a part of the 8-bit OP code. This is possible since only 8 separate addresses located in page zero of the external memory may be specified. Program jumps may also be achieved by loading register HL, IX or IY directly into the PC, thus allowing the jump address to be a complex function of the routine being executed.



The input/output group of instructions in the Z-80 allow for a wide range of transfers between external memory locations or the general purpose CPU registers, and the external I/O devices. In each case, the port number is provided on the lower 8 bits of the address bus during any I/O transaction. One instruction allows this port number to be specified by the second byte of the instruction while other Z-80 instructions allow it to be specified as the content of the C register. One major advantage of using the C register as a pointer to the I/O device is that it allows different I/O ports to share common software driver routines. This is not possible when the address is part of the OP code if the routines are stored in ROM. Another feature of these input instructions is that they set the flag register automatically so that additional operations are not required to determine the state of the input data (for example its parity). The Z-80 CPU includes single instructions that can move blocks of data (up to 256 bytes) automatically to or from any I/O port directly to any memory location. In conjunction with the dual set of general purpose registers, these instructions provide for fast I/O block transfer rates. The value of this I/O instruction set is demonstrated by the fact that the Z-80 CPU can provide all required floppy disk formatting (i.e., the CPU provides the preamble, address, data and enables the CRC codes) on double density floppy disk drives on an interrupt driven basis.

Finally, the basic CPU control instructions allow various options and modes. This group includes instructions such as setting or resetting the interrupt enable flip flop or setting the mode of interrupt response.

5.2 ADDRESSING MODES

Most of the Z-80 instructions operate on data stored in internal CPU registers, external memory or in the I/O ports. Addressing refers to how the address of this data is generated in each instruction. This section gives a brief summary of the types of addressing used in the Z-80 while subsequent sections detail the type of addressing available for each instruction group.

Immediate. In this mode of addressing the byte following the OP code in memory contains the actual operand.

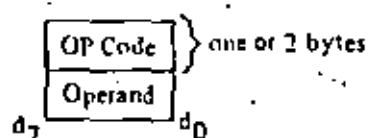

Examples of this type of instruction would be to load the accumulator with a constant, where the constant is the byte immediately following the OP code.

Immediate Extended. This mode is merely an extension of immediate addressing in that the two bytes following the OP codes are the operand.

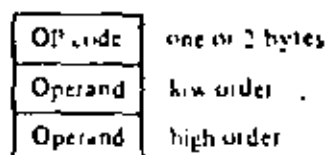

Examples of this type of instruction would be to load the BC register pair (16 bit register) with 16 bits (2 bytes) of data.



Modified Page Zero Addressing. The Z-80 has a special single byte CALL instruction to any of 8 locations in page zero of memory. This instruction (which is referred to as a restart) sets the PC to an effective address in page zero. The value of this instruction is that it allows a single byte to specify a complete 16-bit address where commonly called subroutines are located, thus saving memory space.

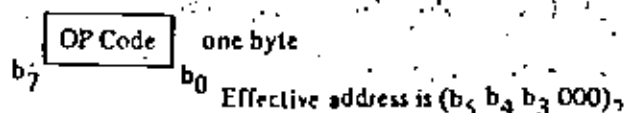

Relative Addressing. Relative addressing uses one byte of data following the OP code to specify a displacement from the existing program to which a program jump can occur. This displacement is a signed two's complement number that is added to the address of the OP code of the following instruction.

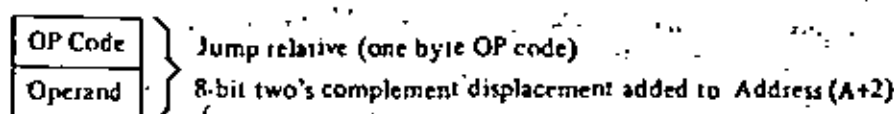

The value of relative addressing is that it allows jumps to nearby locations while only requiring two bytes of memory space. For most programs, relative jumps are by far the most prevalent type of jump due to the proximity of related program segments. Thus, these instructions can significantly reduce memory space requirements. The signed displacement can range between +127 and -128 from A + 2. This allows for a total displacement of +129 to -126 from the jump relative OP code address. Another major advantage is that it allows for relocatable code.

Extended Addressing. Extended Addressing provides for two bytes (16 bits) of address to be included in the instruction. This data can be an address to which a program can jump or it can be an address where an operand is located.

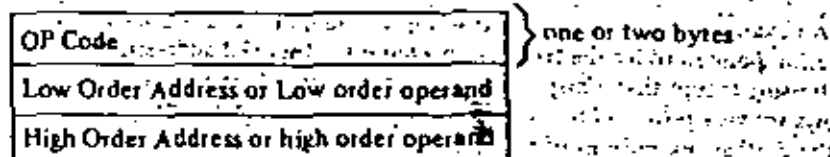

Extended addressing is required for a program to jump from any location in memory to any other location, or load and store data in any memory location.

When extended addressing is used to specify the source or destination address of an operand, the notation (nn) will be used to indicate the content of memory at nn, where nn is the 16-bit address specified in the instruction. This means that the two bytes of address nn are used as a pointer to a memory location. The use of the parentheses always means that the value enclosed within them is used as a pointer to a memory location. For example, (1200) refers to the contents of memory at location 1200.

Indexed Addressing. In this type of addressing, the byte of data following the OP code contains a displacement which is added to one of the two index registers (the OP code specifies which index register is used) to form a pointer to memory. The contents of the index register are not altered by this operation.

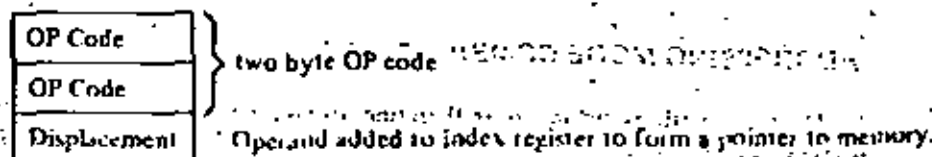

An example of an indexed instruction would be to load the contents of the memory location (Index Register + Displacement) into the accumulator. The displacement is a signed two's complement number. Indexed addressing greatly simplifies programs using tables of data since the index register can point to the start of any table. Two index registers are provided since very often operations require two or more tables. Indexed addressing also allows for relocatable code.

The two index registers in the Z-80 are referred to as IX and IY. To indicate indexed addressing the notation:

(IX+d) or (IY+d)

is used. Here d is the displacement specified after the OP code. The parentheses indicate that this value is used as a pointer to external memory.

Register Addressing. Many of the Z-80 OP codes contain bits of information that specify which CPU register is to be used for an operation. An example of register addressing would be to load the data in register B into register C.

Implied Addressing. Implied addressing refers to operations where the OP code automatically implies one or more CPU registers as containing the operands. An example is the set of arithmetic operations where the accumulator is always implied to be the destination of the results.

Register Indirect Addressing. This type of addressing specifies a 16-bit CPU register pair (such as HL) to be used as a pointer to any location in memory. This type of instruction is very powerful and it is used in a wide range of applications.

OP Code } one or two bytes

An example of this type of instruction would be to load the accumulator with the data in the memory location pointed to by the HL register contents. Indexed addressing is actually a form of register indirect addressing except that a displacement is added with indexed addressing. Register indirect addressing allows for very powerful but simple to implement memory accesses. The block move and search commands in the Z-80 are extensions of this type of addressing where automatic register incrementing, decrementing and comparing has been added. The notation for indicating register indirect addressing is to put parentheses around the name of the register that is to be used as the pointer. For example, the symbol

(HL)

specifies that the contents of the HL register are to be used as a pointer to a memory location. Often register indirect addressing is used to specify 16-bit operands. In this case, the register contents point to the lower order portion of the operand while the register contents are automatically incremented to obtain the upper portion of the operand.

Bit Addressing. The Z-80 contains a large number of bit set, reset and test instructions. These instructions allow any memory location or CPU register to be specified for a bit operation through one of three previous addressing modes (register, register indirect and indexed) while three bits in the OP code specify which of the eight bits is to be manipulated.

ADDRESSING MODE COMBINATIONS

Many instructions include more than one operand (such as arithmetic instructions or loads). In these cases, two types of addressing may be employed. For example, load can use immediate addressing to specify the source and register indirect or indexed addressing to specify the destination.



5.3 INSTRUCTION OP CODES

This section describes each of the Z-80 instructions and provides tables listing the OP codes for every instruction. In each of these tables the OP codes in shaded areas are identical to those offered in the 8080A CPU. Also shown is the assembly language mnemonic that is used for each instruction. All instruction OP codes are listed in hexadecimal notation. Single byte OP codes require two Hex characters while double byte OP codes require four hex characters. The conversion from hex to binary is repeated here for convenience.

Hex	Binary	Decimal	Hex	Binary	Decimal
0	= 0000	= 0	8	= 1000	= 8
1	= 0001	= 1	9	= 1001	= 9
2	= 0010	= 2	A	= 1010	= 10
3	= 0011	= 3	B	= 1011	= 11
4	= 0100	= 4	C	= 1100	= 12
5	= 0101	= 5	D	= 1101	= 13
6	= 0110	= 6	E	= 1110	= 14
7	= 0111	= 7	F	= 1111	= 15

Z-80 instruction mnemonics consist of an OP code and zero, one or two operands. Instructions in which the operand is implied have no operand. Instructions which have only one logical operand or those in which one operand is invariant (such as the Logical OR instruction) are represented by a one operand mnemonic. Instructions which may have two varying operands are represented by two operand mnemonics.

LOAD AND EXCHANGE

Table 5.3-1 defines the OP code for all of the 8-bit load instructions implemented in the Z-80 CPU. Also shown in this table is the type of addressing used for each instruction. The source of the data is found on the top horizontal row while the destination is specified by the left hand column. For example, load register C from register B uses the OP code 48H. In all of the tables the OP code is specified in hexadecimal notation and the 48H (=0100 1000 binary) code is fetched by the CPU from the external memory during M1 time, decoded and then the register transfer is automatically performed by the CPU.

The assembly language mnemonic for this entire group is LD, followed by the destination followed by the source (LD DEST., SOURCE). Note that several combinations of addressing modes are possible. For example, the source may use register addressing and the destination may be register indirect; such as load the memory location pointed to by register HL with the contents of register D. The OP code for this operation would be 72. The mnemonic for this load instruction would be as follows:

LD (HL), D

The parentheses around the HL means that the contents of HL are used as a pointer to a memory location. In all Z-80 load instruction mnemonics the destination is always listed first, with the source following. The Z-80 assembly language has been defined for ease of programming. Every instruction is self documenting and programs written in Z-80 language are easy to maintain.

Note in table 5.3-1 that some load OP codes that are available in the Z-80 use two bytes. This is an efficient method of memory utilization since 8, 16, 24 or 32 bit instructions are implemented in the Z-80. Thus often utilized instructions such as arithmetic or logical operations are only 8-bits which results in better memory utilization than is achieved with fixed instruction sizes such as 16-bits.

All load instructions using indexed addressing for either the source or destination location actually use three bytes of memory with the third byte being the displacement d. For example a load register E with the operand pointed to by IX with an offset of +8 would be written:

LD E, (IX + 8)



The instruction sequence for this in memory would be:

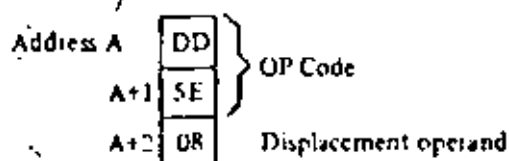

The two extended addressing instructions are also three byte instructions. For example the instruction to load the accumulator with the operand in memory location 6F32H would be written:

LD A, (6F 32H)

and its instruction sequence would be:

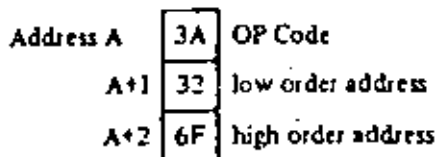

Notice that the low order portion of the address is always the first operand.

The load immediate instructions for the general purpose 8-bit registers are two-byte instructions. The instruction load register H with the value 36H would be written:

LD H, 36H

and its sequence would be:

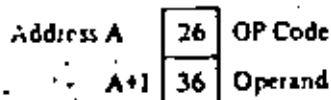

Loading a memory location using indexed addressing for the destination and immediate addressing for the source requires four bytes. For example:

LD (IX - 15), 21H

would appear as:

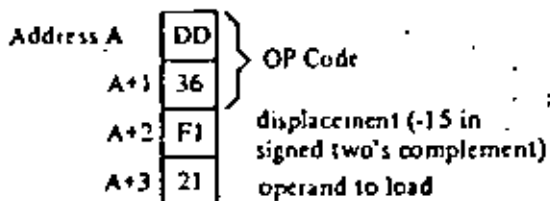

Notice that with any indexed addressing the displacement always follows directly after the OP code.

Table 5.3-2 specifies the 16-bit load operations. This table is very similar to the previous one. Notice that the extended addressing capability covers all register pairs. Also notice that register indirect operations specifying the stack pointer are the PUSH and POP instructions. The mnemonic for these instructions is "PUSH" and "POP." These differ from other 16-bit loads in that the stack pointer is automatically decremented and incremented as each byte is pushed onto or popped from the stack respectively. For example the instruction:



PUSH AF

is a single byte instruction with the OP code of F5H. When this instruction is executed the following sequence is generated:

Decrement SP

LD (SP), A

Decrement SP

LD (SP), F

Thus the external stack now appears as follows:

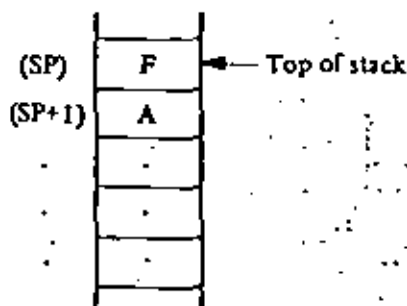

SOURCE

	OPERAND	REGISTERS								REG. ADDRESS			HIGH BYTE		LEFT ADDRESS		MODE	
		B	C	D	E	H	L	PC	SP	HL	BC	DE	HL	SP	HL	SP		
PUSH AF	A	00	00	00	00	00	00	00	00	00	00	00	00	00	00	00	00	00
	B																	
	C																	
	D																	
	E																	
	H																	
	L																	
PUSH BC	BC																	
	BC																	
	BC																	
PUSH DE	DE																	
	DE																	
PUSH HL	HL																	
	HL																	
PUSH SP	SP																	
	SP																	
PUSH PC	PC																	
	PC																	

8 BIT LOAD GROUP

'LD'

TABLE 5.3-1



The POP instruction is the exact reverse of a PUSH. Notice that all PUSH and POP instructions utilize a 16-bit operand and the high order byte is always pushed first and popped last. That is a:

PUSH BC is PUSH B then C

PUSH DE is PUSH D then E

PUSH HL is PUSH H then L

POP HL is POP L then H

The instruction using extended immediate addressing for the source obviously requires 2 bytes of data following the OP code. For example:

LD DE, 0659H

will be:

Address A	11	OP Code
A+1	59	Low order operand to register E
A+2	06	High order operand to register D

In all extended immediate or extended addressing modes, the low order byte always appears first after the OP code.

Table 5.3.3 lists the 16-bit exchange instructions implemented in the Z80. OP code 0x18 allows the programmer to switch between the two pairs of accumulator flag registers while DPH allows the programmer to switch between the duplicate set of six general purpose registers. These OP codes are only one byte in length to absolutely minimize the time necessary to perform the exchange so that the duplicate banks can be used to effect very fast interrupt response times.

BLOCK TRANSFER AND SEARCH

Table 5.3.4 lists the extremely powerful block transfer instructions. All of these instructions operate with three registers.

HL points to the source location.

DE points to the destination location.

BC is a byte counter.

After the programmer has initialized these three registers, any of these four instructions may be used. The LDI (Load and Increment) instruction moves one byte from the location pointed to by HL to the location pointed to by DE. Register pairs HL and DE are then automatically incremented and are ready to point to the following locations. The byte counter (register pair BC) is also incremented at this time. This instruction is valuable when blocks of data must be moved but other types of processing are required between each move. The LDIR (Load, increment and repeat) instruction is an extension of the LDI instruction. The same load and increment operation is repeated until the byte counter reaches the count of zero. Thus, this single instruction can move any block of data from one location to any other.

Note that since 16-bit registers are used, the size of the block can be up to 64K bytes (1K = 1024) long and it can be moved from any location in memory to any other location. Furthermore the blocks can be overlapping since there are absolutely no constraints on the data that is used in the three register pairs.

The LDD and LDOR instructions are very similar to the LDI and LDIR. The only difference is that register pairs HL and DE are decremented after every move so that a block transfer starts from the highest address of the designated block rather than the lowest.

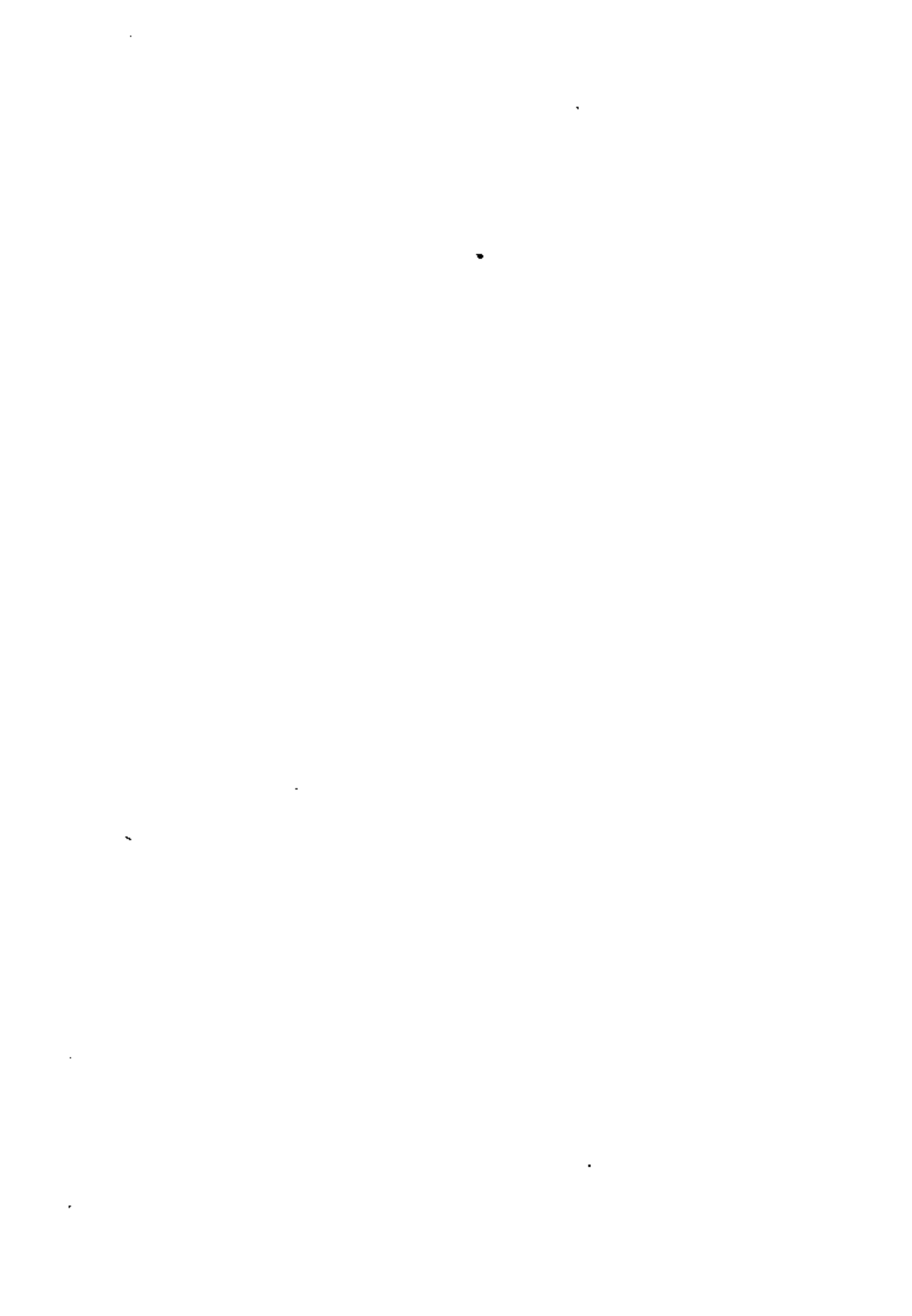

SOURCE

		REGISTER						IMM. EXT.	EXT. ADDR.	REG. INDR.	
		AF	BC	DE	HL	SP	IX	IY	(m)	(m)	(SP)
DESTINATION	REGISTER	AF									F1
	BC							01 r r	ED 4B r r		C1
	DE							11 r r	ED 5B r r		D1
	HL							21 r r	2A r r		E1
	SP				FS		DD FB r r	FD F9 r r	ED 7B r r		
	IX						DD 21 r r		DD 2A r r	DD E1	
	IY						FD 21 r r		FD 2A r r	FD E1	
	EXT. ADDR.	(m)		ED 43 r r	ED 53 r r	22 r r	ED 73 r r	DD 22 r r	FD 22 r r		
PUSH INSTRUCTIONS →	REG. INDR.	(SP)	FS	CS	DS	ES	DD EB r r	FD EB r r			

POP INSTRUCTIONS ↑

NOTE: The Push & Pop Instructions adjust the SP after every execution

16 BIT LOAD GROUP

'LD', 'LDH', 'LDHL', 'LDD', 'LDI', 'LDDI', 'LDDH', 'LDH', 'LDHL', 'LDI', 'LDDI', 'LDDH'
'PUSH' AND 'POP'
TABLE 5.3-2

		IMPLIED ADDRESSING				
		AF	BC, DE & HL	HL	IX	IY
IMPLIED	AF	0B				
	BC, DE & HL		0B			
	DE			EB		
REG. INDR.	(SP)			EB	DD EB r r	FD EB r r

EXCHANGES 'EX' AND 'EXX'
TABLE 5.3-3

		SOURCE		
		REG. INDIR.	(HL)	
DESTINATION	REG. INDIR.	IDEB	ED A0	'LDI' - Load (DE) → (HL) Inc HL & DE, Dec BC
			ED B0	'LDIR' - Load (DE) → (HL) Inc HL & DE, Dec BC, Repeat until BC = 0
			ED A8	'LDD' - Load (DE) → (HL) Dec HL & DE, Dec BC
			ED B8	'LDDR' - Load (DE) → (HL) Dec HL & DE, Dec BC, Repeat until BC = 0

Reg HL points to source
Reg DE points to destination
Reg BC is byte counter

BLOCK TRANSFER GROUP

TABLE 5.3-4

Table 5.3-5 specifies the OP codes for the four block search instructions. The first, CPI (compare and increment) compares the data in the accumulator, with the contents of the memory location pointed to by register HL. The result of the compare is stored in one of the flag bits (see section 6.0 for a detailed explanation of the flag operations) and the HL register pair is then incremented and the byte counter (register pair BC) is decremented.

The instruction CPIX is merely an extension of the CPI instruction in which the compare is repeated until either a match is found or the byte counter (register pair BC) becomes zero. Thus, this single instruction can search the entire memory for any 8-bit character.

The CPD (Compare and Decrement) and CPDR (Compare, Decrement and Repeat) are similar instructions, their only difference being that they decrement HL after every compare so that they search the memory in the opposite direction. (The search is started at the highest location in the memory block).

It should be emphasized again that these block transfer and compare instructions are extremely powerful in string manipulation applications.

ARITHMETIC AND LOGICAL

Table 5.3-6 lists all of the 8-bit arithmetic operations that can be performed with the accumulator, also listed are the increment (INC) and decrement (DEC) instructions. In all of these instructions, except INC and DEC, the specified 8-bit operation is performed between the data in the accumulator and the source data specified in the table. The result of the operation is placed in the accumulator with the exception of compare (CP) that leaves the accumulator unaffected. All of these operations affect the flag register as a result of the specified operation. (Section 6.0 provides all of the details on how the flags are affected by any instruction type). INC and DEC instructions specify a register or a memory location as both source and destination of the result. When the source operand is addressed using the index registers the displacement must follow directly. With immediate addressing the actual operand will follow directly. For example the instruction:

would appear as:

		AND 07H		
Address A	E6	DP Code		
At1	07	Operand		

SEARCH
LOCATION

REG. INDIR.	
(HL)	
ED A1.	'CPI' Inc HL, Dec BC
ED B1	'CPIR', Inc HL, Dec BC repeat until BC = 0 or find match
ED A5	'CPD' Dec HL & BC
ED B0	'CPDR' Dec HL & BC Repeat until BC = 0 or find match

HL points to location in memory
to be compared with accumulator
contents
BC is byte counter

BLOCK SEARCH GROUP

TABLE 5.3-5

Assuming that the accumulator contained the value F3H the result of 03H would be placed in the accumulator:

Acc before operation	1111 0011 = F3H
Operand	0000 0111 = 07H
Result to Acc	0000 0011 = 03H

The Add instruction (ADD) performs a binary add between the data in the source location and the data in the accumulator. The subtract (SUB) does a binary subtraction. When the add with carry is specified (ADC) or the subtract with carry (SBC), then the carry flag is also added or subtracted respectively. The flags and decimal adjust instruction (DAA) in the Z-80 (fully described in section 6.0) allow arithmetic operations for:

- multiprecision packed BCD numbers
- multiprecision signed or unsigned binary numbers
- multiprecision two's complement signed numbers

Other instructions in this group are logical and (AND), logical or (OR), exclusive or (XOR) and compare (CP).

There are five general purpose arithmetic instructions that operate on the accumulator or carry flag. These five are listed in table 5.3.7. The decimal adjust instruction can adjust for subtraction as well as addition, thus making BCD arithmetic operations simple. Note that to allow for this operation the flag N is used. This flag is set if the last arithmetic operation was a subtract. The negate accumulator (NEG) instruction forms the two's complement of the number in the accumulator. Finally notice that a reset carry instruction is not included in the Z-80 since this operation can be easily achieved through other instructions such as a logical AND of the accumulator with itself.

Table 5.3-8 lists all of the 16-bit arithmetic operations between 16-bit registers. There are five groups of instructions including add with carry and subtract with carry. ADC and SBC affect all of the flags. These two groups simplify address calculation operations or other 16-bit arithmetic operations.

SOURCE

	REGISTER ADDRESSING							REG. INDIR.	INDEXED		IMMED.
	A	B	C	D	E	H	L	(HL)	(IX+d)	(IY+d)	n
'ADD'	37	38	39	3A	3B	3C	3D	3E	DD 3E d	FD 3E d	CE n
ADD w CARRY 'ADC'	BF	B8	B9	BA	BB	BC	BD	BE	DD BE d	FD BE d	CE n
SUBTRACT 'SUB'	97	98	99	9A	9B	9C	9D	9E	DD 9E d	FD 9E d	DE n
SUB w CARRY 'SBC'	BF	B8	B9	BA	BB	BC	BD	BE	DD BE d	FD BE d	DE n
'AND'	A7	A8	A9	AA	AB	AC	AD	AE	DD AE d	FD AE d	EE n
'XOR'	AF	AB	AC	AD	AE	AF	AG	AH	DD AH d	FD AH d	EE n
'OR'	B7	B8	B9	BA	BB	BC	BD	BE	DD BE d	FD BE d	FE n
COMPARE 'CP'	BF	B8	B9	BA	BB	BC	BD	BE	DD BE d	FD BE d	FE n
INCREMENT 'INC'	3C	3D	3E	3F	40	41	42	43	DD 34 d	FD 34 d	
DECREMENT 'DEC'	3D	3E	3F	40	41	42	43	44	DD 3E d	FD 3E d	

8 BIT ARITHMETIC AND LOGIC

TABLE 5.3-6

Decimal Adjust Acc. 'DAA'	37
Complement Acc. 'CPL'	2F
Negate Acc. 'NEG' (2's complement)	ED 44
Complement Carry Flag 'CF'	2F
Set Carry Flag 'SCF'	37

GENERAL PURPOSE AF OPERATIONS

TABLE 5.3-7

		SOURCE					
		BC	DE	HL	SP	IX	IV
DESTINATION	'ADD'	HL	08 09	18 19	28 29	38 39	
		IX	DD 09	DD 19		DD 39	DD 29
		IV	FD 09	FD 19		FD 39	FD 29
	ADD WITH CARRY AND SET FLAGS 'ADC'	HL	ED 4A	ED 5A	ED 6A	ED 7A	
	SUB WITH CARRY AND SET FLAGS 'SBC'	HL	ED 42	ED 52	ED 62	ED 72	
	INCREMENT 'INC'		03	13	23	33	DD 23 FD 23
	DECREMENT 'DEC'		0B	1B	2B	3B	DD 2B FD 2B

16 BIT ARITHMETIC
TABLE 5.3-8

ROTATE AND SHIFT

A major capability of the Z-80 is its ability to rotate or shift data in the accumulator, any general purpose register, or any memory location. All of the rotate and shift OP codes are shown in table 5.3-9. Also included in the Z-80 are arithmetic and logical shift operations. These operations are useful in an extremely wide range of applications including integer multiplication and division. Two BCD digit rotate instructions (RRD and RLD) allow a digit in the accumulator to be rotated with the two digits in a memory location pointed to by register pair HL. (See figure 5.3-9). These instructions allow for efficient BCD arithmetic.

BIT MANIPULATION

The ability to set, reset and test individual bits in a register or memory location is needed in almost every program. These bits may be flags in a general purpose software routine, indications of external control conditions or data packed into memory locations to make memory utilization more efficient.

The Z-80 has the ability to set, reset or test any bit in the accumulator, any general purpose register or any memory location with a single instruction. Table 5.3-10 lists the 240 instructions that are available for this purpose. Register addressing can specify the accumulator or any general purpose register on which the operation is to be performed. Register indirect and indexed addressing are available to operate on external memory locations. Bit test operations set the zero flag (Z) if the tested bit is a zero. (Refer to section 6.0 for further explanation of flag operation).

JUMP, CALL AND RETURN

Figure 5.3-11 lists all of the jump, call and return instructions implemented in the Z-80 CPU. A jump is a branch in a program where the program counter is loaded with the 16-bit value as specified by one of the three available addressing modes (Immediate Extended, Relative or Register Indirect). Notice that the jump group has several different conditions that can be specified to be met before the jump will be made. If these conditions are not met, the program merely continues with the next sequential instruction. The conditions are all dependent on the data in the flag register. (Refer to section 6.0 for details on the flag register). The immediate extended addressing is used to jump to any location in the memory. This instruction requires three bytes (two to specify the 16-bit address) with the low order address byte first followed by the high order address byte.



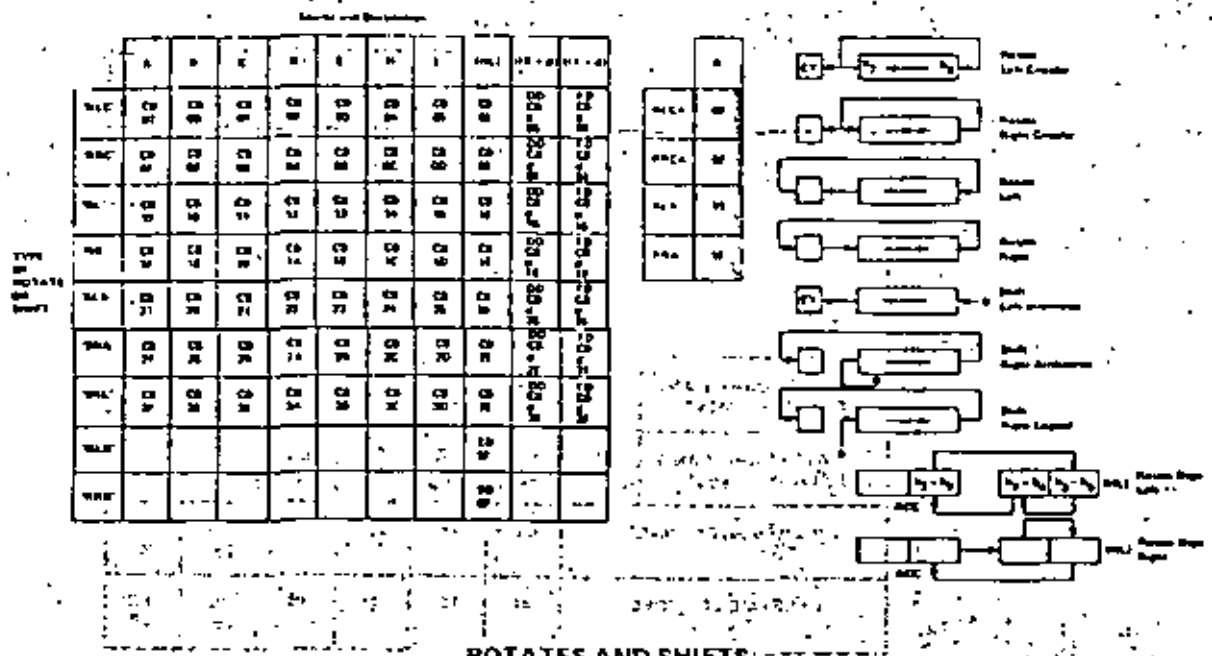

ROTATES AND SHIFTS
TABLE 53-9

Address A	C3	OP Code
A+1	32	Low order address
A+2	3E	High order address

For example an unconditional Jump to memory location 3E32H would be done via the instruction C3 32 3E. The instruction C3 is the OP code, 32 is the low order address, and 3E is the high order address. The instruction C3 32 3E would be fetched from memory location A. The instruction C3 32 3E would be fetched from memory location A. The instruction C3 32 3E would be fetched from memory location A. The instruction C3 32 3E would be fetched from memory location A.

The relative jump instruction uses only two bytes, the second byte is a signed two's complement displacement from the existing PC. This displacement can be in the range of +129 to -126 and is measured from the address of the instruction OP code.

Three types of register indirect jumps are also included. These instructions are implemented by loading the register pair HL or one of the index registers IX or IY directly into the PC. This capability allows for program jumps to be a function of previous calculations.

A call is a special form of a jump where the address of the byte following the call instruction is pushed onto the stack before the jump is made. A return instruction is the reverse of a call because the data on the top of the stack is popped directly into the PC to form a jump address. The call and return instructions allow for simple subroutine and interrupt handling. Two special return instructions have been included in the Z-80 family of components. The return from interrupt instruction (RETI) and the return from non maskable interrupt (RETN) are treated in the CPU as an unconditional return identical to the OP code C9H. The difference is that (RETI) can be used at the end of an interrupt routine and all Z-80 peripheral chips will recognize the execution of this instruction for proper control of nested priority interrupt handling. This instruction coupled with the Z-80 peripheral devices implementation simplifies the normal return from nested interrupt. Without this feature the following software sequence would be necessary to inform the interrupting device that the interrupt routine is completed:



BIT	REGISTER ADDRESSING							REG. ADDR.	INDEXED	
	A	B	C	D	E	F	G		REG.	BY-#
0	00	00	00	00	00	00	00	00	00	00
1	00	00	00	00	00	00	00	00	00	00
2	00	00	00	00	00	00	00	00	00	00
3	00	00	00	00	00	00	00	00	00	00
4	00	00	00	00	00	00	00	00	00	00
5	00	00	00	00	00	00	00	00	00	00
6	00	00	00	00	00	00	00	00	00	00
7	00	00	00	00	00	00	00	00	00	00
8	00	00	00	00	00	00	00	00	00	00
9	00	00	00	00	00	00	00	00	00	00
10	00	00	00	00	00	00	00	00	00	00
11	00	00	00	00	00	00	00	00	00	00
12	00	00	00	00	00	00	00	00	00	00
13	00	00	00	00	00	00	00	00	00	00
14	00	00	00	00	00	00	00	00	00	00
15	00	00	00	00	00	00	00	00	00	00
16	00	00	00	00	00	00	00	00	00	00
17	00	00	00	00	00	00	00	00	00	00
18	00	00	00	00	00	00	00	00	00	00
19	00	00	00	00	00	00	00	00	00	00
20	00	00	00	00	00	00	00	00	00	00
21	00	00	00	00	00	00	00	00	00	00
22	00	00	00	00	00	00	00	00	00	00
23	00	00	00	00	00	00	00	00	00	00
24	00	00	00	00	00	00	00	00	00	00
25	00	00	00	00	00	00	00	00	00	00
26	00	00	00	00	00	00	00	00	00	00
27	00	00	00	00	00	00	00	00	00	00
28	00	00	00	00	00	00	00	00	00	00
29	00	00	00	00	00	00	00	00	00	00
30	00	00	00	00	00	00	00	00	00	00
31	00	00	00	00	00	00	00	00	00	00

BIT MANIPULATION GROUP
TABLE 5.3-10



- Disable Interrupt — prevent interrupt before routine is exited.
- LD A, n
OUT n, A — notify peripheral that service routine is complete
- Enable Interrupt
- Return

This seven byte sequence can be replaced with the one byte EI instruction and the two byte RETI instruction in the Z80. This is important since interrupt service time often must be minimized.

To facilitate program loop control the instruction DJNZ can be used advantageously. This two byte, relative jump instruction decrements the B register and the jump occurs if the B register has not been decremented to zero. The relative displacement is expressed as a signed two's complement number. A simple example of its use might be:

Address	Instruction	Comments
N, N+1	LD B, 7	; set B register to count of 7
N+2 to N+9	(Perform a sequence of instructions)	; loop to be performed 7 times
N+10, N+11	DJNZ -8	; to jump from N+12 to N+2
N+12	(Next instruction)	

CONDITION

			LN-COND.	CARRY	NON CARRY	ZERO	NON ZERO	PARITY EVEN	PARITY ODD	SIGN NEG	SIGN POS	RES B=8
JUMP 'JP'	IMMED. EXT.	m	C3 n n	D4 n n	D2 n n	CA n n	C2 n n	E4 n n	E2 n n	F4 n n	F2 n n	
JUMP 'JR'	RELATIVE	PC+n	7B +2	3B +2	30 +2	7B +2	20 +2					
JUMP 'JP'	REG. INDIR.	(HL)	E9									
JUMP 'JP'		(IX)	D0 E9									
JUMP 'JP'		(IY)	F0 E9									
'CALL'	IMMED. EXT.	m	C3 n n	D4 n n	D2 n n	CA n n	C2 n n	E4 n n	E2 n n	F4 n n	F2 n n	
DECREMENT B, JUMP IF NON ZERO 'DJNZ'	RELATIVE	PC+n										10 +2
RETURN 'RET'	REGISTER INDIR.	(SP) (SP+1)	C3	D6	D0	C3	C0	E3	E0	F3	F0	
RETURN FROM INT 'RETI'	REG. INDIR.	(SP) (SP+1)	E3	4D								
RETURN FROM NON MASKABLE INT 'RETI'	REG. INDIR.	(SP) (SP+1)	E3	45								

NOTE—CERTAIN FLAGS HAVE MORE THAN ONE PURPOSE. REFER TO SECTION 5.0 FOR DETAILS

JUMP, CALL and RETURN GROUP
TABLE 5.3-11



Table 5.3-12 lists the eight OP codes for the restart instruction. This instruction is a single byte call to any of the eight addresses listed. The simple mnemonic for these eight calls is also shown. The value of this instruction is that frequently used routines can be called with this instruction to minimize memory usage.

		OP CODE	
CALL ADDRESS	0000 _H	C7	'RET 0'
	0008 _H	CF	'RET 8'
	0010 _H	D7	'RET 16'
	0018 _H	DF	'RET 24'
	0020 _H	E7	'RET 32'
	0028 _H	EF	'RET 40'
	0030 _H	F7	'RET 48'
	0038 _H	FF	'RET 56'

RESTART GROUP

TABLE 5.3-12

SUGGESTED
BT-52955AT

RESTART GROUP

The Z-80 has an extensive set of Input and Output instructions as shown in table 5.3-13 and table 5.3-14. The addressing of the input or output device can be either absolute or register indirect, using the C register. Notice that in the register indirect addressing mode data can be transferred between the I/O devices and any of the internal registers. In addition eight block transfer instructions have been implemented. These instructions are similar to the memory block transfers except that they use register pair HL for a pointer to the memory source (output commands) or destination (input commands) while register B is used as a byte counter. Register C holds the address of the port for which the input or output command is desired. Since register B is eight bits in length, the I/O block transfer command handles up to 256 bytes.

In the instructions IN A, n and OUT n, A the I/O device address n appears in the lower half of the address bus (A₇-A₀) while the accumulator content is transferred in the upper half of the address bus. In all register indirect input output instructions, including block I/O transfers the content of register C is transferred to the lower half of the address bus (device address) while the content of register B is transferred to the upper half of the address bus.

SOURCE
PORT ADDRESS

		IMMED.	REG. INDIR.
		(n)	(C)
INPUT DESTINATION	REG. ADDRESSING	A DB 7F	ED 7B
		B	ED 40
		C	ED 4B
		D	ED 50
		E	ED 5B
		H	ED 60
	L	ED 6B	
'INI' - INPUT & Inc HL, Dec B			ED A2
'INR' - INP, Inc HL, Dec B, REPEAT IF B ≠ 0			ED B7
'IND' - INPUT & Dec HL, Dec B			ED AA
'INDR' - INPUT, Dec HL, Dec B, REPEAT IF B ≠ 0			ED BA
		(HL)	

BLOCK INPUT COMMANDS

INPUT GROUP
TABLE 5.3-13

CPU CONTROL GROUP

The final table, table 5.3-15 illustrates the six general purpose CPU control instructions. The NOP is a do-nothing instruction. The HALT instruction suspends CPU operation until a subsequent interrupt is received, while the DI and EI are used to lock out and enable interrupts. The three interrupt mode commands set the CPU into any of the three available interrupt response modes as follows. If mode zero is set the interrupting device can insert any instruction on the data bus and allow the CPU to execute it. Mode 1 is a simplified mode where the CPU automatically executes a restart (RST) to location 0038H so that no external hardware is required. (The old PC content is pushed onto the stack). Mode 2 is the most powerful in that it allows for an indirect call to any location in memory. With this mode the CPU forms a 16-bit memory address where the upper 8-bits are the content of register I and the lower 8-bits are supplied by the interrupting device. This address points to the first of two sequential bytes in a table where the address of the service routine is located. The CPU automatically obtains the starting address and performs a CALL to this address.





			SOURCE							
			REGISTER							REG. IND.
			A	B	C	D	E	H	L	(HL)
'OUT'	IMMED.	(n)	D3 D7							
	REG. IND.	(C)	ED 79	ED 41	ED 4B	ED 51	ED 59	ED 61	ED 69	
'OUTI' - OUTPUT Inc HL, Dec B	REG. IND.	(C)								ED A3
'OUTR' - OUTPUT, Inc HL, Dec B, REPEAT IF B=0	REG. IND.	(C)								ED B3
'OUTD' - OUTPUT Dec HL & B	REG. IND.	(C)								ED A8
'OTDR' - OUTPUT, Dec HL & B, REPEAT IF B=0	REG. IND.	(C)								ED B8

PORT
DESTINATION
ADDRESS

BLOCK
OUTPUT
COMMANDS

OUTPUT GROUP
TABLE 5.3-14

'NOP'	D0	
'HALT'	78	
DISABLE INT 'DI'	F3	
ENABLE INT 'EI'	F8	
SET INT MODE 0 'IM0'	ED 46	BDSGA MODE
SET INT MODE 1 'IM1'	ED 58	CALL TO LOCATION 0038 _H
SET INT MODE 2 'IM2'	ED 5E	INDIRECT CALL USING REGISTER I AND 2 BITS FROM INTERRUPTING DEVICE AS A POINTER.

MISCELLANEOUS CPU CONTROL
TABLE 5.3-15

6.0 FLAGS

Each of the two Z-80 CPU Flag registers contains six bits of information which are set or reset by various CPU operations. Four of these bits are testable; that is, they are used as conditions for jump, call or return instructions. For example a jump may be desired only if a specific bit in the flag register is set. The four testable flag bits are:

- 1) Carry Flag (C) – This flag is the carry from the highest order bit of the accumulator. For example, the carry flag will be set during an add instruction where a carry from the highest bit of the accumulator is generated. This flag is also set if a borrow is generated during a subtraction instruction. The shift and rotate instructions also affect this bit.
- 2) Zero Flag (Z) – This flag is set if the result of the operation loaded a zero into the accumulator. Otherwise it is reset.
- 3) Sign Flag (S) – This flag is intended to be used with signed numbers and it is set if the result of the operation was negative. Since bit 7 (MSB) represents the sign of the number (A negative number has a 1 in bit 7), this flag stores the state of bit 7 in the accumulator.
- 4) Parity/Overflow Flag (P/V) – This dual purpose flag indicates the parity of the result in the accumulator when logical operations are performed (such as AND, A, B) and it represents overflow when signed two's complement arithmetic operations are performed. The Z-80 overflow flag indicates that the two's complement number in the accumulator is in error since it has exceeded the maximum possible (+127) or is less than the minimum possible (-128) number than can be represented in two's complement notation. For example consider adding:

$$\begin{array}{r} +120 = 0111\ 1000 \\ +105 = 0110\ 1001 \\ \hline C = 0\ 1110\ 0001 = -95 \text{ (wrong) Overflow has occurred} \end{array}$$

Here the result is incorrect. Overflow has occurred and yet there is no carry to indicate an error. For this case the overflow flag would be set. Also consider the addition of two negative numbers:

$$\begin{array}{r} -5 = 1111\ 1011 \\ -16 = 1111\ 0000 \\ \hline C = 1\ 1110\ 1011 = -21 \text{ correct} \end{array}$$

Notice that the answer is correct but the carry is set so that this flag can not be used as an overflow indicator. In this case the overflow would not be set.

For logical operations (AND, OR, XOR) this flag is set if the parity of the result is even and it is reset if it is odd.

There are also two non-testable bits in the flag register. Both of these are used for BCD arithmetic. They are:

- 1) Half carry (H) – This is the BCD carry or borrow result from the least significant four bits of operation. When using the DAA (Decimal Adjust Instruction) this flag is used to correct the result of a previous packed decimal add or subtract.
- 2) Subtract Flag (N) – Since the algorithm for correcting BCD operations is different for addition or subtraction, this flag is used to specify what type of instruction was executed last so that the DAA operation will be correct for either addition or subtraction.

The Flag register can be accessed by the programmer and its format is as follows:

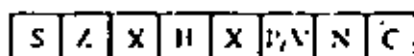

X means flag is indeterminate.

Table 6.0-1 lists how each flag bit is affected by various CPU instructions. In this table a '•' indicates that the instruction does not change the flag, an 'X' means that the flag goes to an indeterminate state, a '0' means that it is reset, a '1' means that it is set and the symbol 'Z' indicates that it is set or reset according to the previous discussion. Note that any instruction not appearing in this table does not affect any of the flags.

Table 6.0-1 includes a few special cases that must be described for clarity. Notice that the block search instruction sets the Z flag if the last compare operation indicated a match between the source and the accumulator data. Also, the parity flag is set if the byte counter (register pair BC) is not equal to zero. This same use of the parity flag is made with the block move instructions. Another special case is during block input or output instructions, here the Z flag is used to indicate the state of register B which is used as a byte counter. Notice that when the I/O block transfer is complete, the zero flag will be reset to a zero (i.e. B=0) while in the case of a block move command the parity flag is reset when the operation is complete. A final case is when the refresh or I register is loaded into the accumulator, the interrupt enable flip flop is loaded into the parity flag so that the complete state of the CPU can be saved at any time.



Instruction	C	Z	S	P/V	H	N	Comments
ADD A, s; ADC A, s	1	1	V	1	0	1	8-bit add or add with carry
SUB A, s; SBC A, s; CPA; NEG	1	1	V	1	1	1	8-bit subtract, subtract with carry, compare and negate accumulator
AND s	0	1	P	1	0	1	Logical operations
OR s; NOR s	0	1	P	1	0	0	And set's different flags
INC s	0	1	V	1	0	1	8-bit increment
DEC s	0	1	V	1	1	1	8-bit decrement
ADD DD, m	1	0	0	0	0	X	16-bit add
ADC HL, m	1	1	V	1	0	X	16-bit add with carry
SBC HL, m	1	1	V	1	1	X	16-bit subtract with carry
RLA; RLCA, RRA, RRCA	1	0	0	0	0	0	Rotate accumulator
RL m; RLC m; RR m; RRC m SLA m; SRA m; SRL m	1	1	P	1	0	0	Rotate and shift location m
RLD, RRD	0	1	P	1	0	0	Rotate digit left and right
DAA	1	1	P	1	0	1	Decimal adjust accumulator
CPL	0	0	0	0	1	1	Complement accumulator
SCF	1	0	0	0	0	0	Set carry
CCF	1	0	0	0	0	X	Complement carry
IN r, (C)	0	1	P	1	0	0	Input register indirect
INI; IND; OUTI; OUTD	0	1	X	X	1	X	Block input and output
INIR; INDR; OTIR; OTDR	0	1	X	X	1	X	Z = 0 if B ≠ 0 otherwise Z = 1
LDI, LDD	0	X	1	X	0	0	Block transfer instructions
LDIR, LDDR	0	X	0	X	0	0	P/V = 1 if BC ≠ 0, otherwise P/V = 0
CPI, CPIR, CPD, CPDR	0	1	1	1	1	X	Block search instructions Z = 1 if A = (HL), otherwise Z = 0 P/V = 1 if BC ≠ 0, otherwise P/V = 0
LD A, I; LD A, R	0	1	FF	1	0	0	The content of the interrupt enable flip-flop (IFF) is copied into the P/V flag
BIT b, s	0	1	X	X	0	1	The state of bit b of location s is copied into the Z flag
NEG	1	1	V	1	1	1	Negate accumulator

The following notation is used in this table:

Symbol	Operation
C	Carry/borrow flag. C=1 if the operation produced a carry from the MSB of the operand or result.
Z	Zero flag. Z=1 if the result of the operation is zero.
S	Sign flag. S=1 if the MSB of the result is one.
P/V	Parity or overflow flag. Parity (P) and overflow (V) share the same flag. Logical operations affect the flag with the parity of the result while arithmetic operations affect the flag with the overflow of the result. If P/V holds parity, P/V=1 if the result of the operation is even, P/V=0 if result is odd. If P/V holds overflow, P/V=1 if the result of the operation produced an overflow.
H	Half-carry flag. H=1 if the add or subtract operation produced a carry into or borrow from bit 4 of the accumulator.
N	Add/Subtract flag. N=1 if the previous operation was a subtract.
	H and N flags are used in conjunction with the decimal adjust instructions (DAA) to properly correct the result into packed BCD format following addition or subtraction using operands with packed BCD format.
1	The flag is affected according to the result of the operation.
0	The flag is unchanged by the operation.
D	The flag is reset by the operation.
1	The flag is set by the operation.
X	The flag is a "don't care."
V	P/V flag affected according to the overflow result of the operation.
P	P/V flag affected according to the parity result of the operation.
r	Any one of the CPU registers A, B, C, D, E, H, L.
s	Any 8-bit location for all the addressing modes allowed for the particular instruction.
m	Any 16-bit location for all the addressing modes allowed for that instruction.
I	Any one of the two index registers IX or IY.
R	Refresh number.
b	8-bit value in range <0, 255>
mm	16-bit value in range <0, 65535>
m	Any 8-bit location for all the addressing modes allowed for the particular instruction.

SUMMARY OF FLAG OPERATION

TABLE 6.0-1



7.0 SUMMARY OF OP CODES AND EXECUTION TIMES

The following section gives a summary of the Z-80 instructions set. The instructions are logically arranged into groups as shown on tables 7.0-1 through 7.0-11. Each table shows the assembly language mnemonic OP code, the actual OP code, the symbolic operation, the content of the flag register following the execution of each instruction, the number of bytes required for each instruction as well as the number of memory cycles and the total number of T states (external clock periods) required for the fetching and execution of each instruction. Care has been taken to make each table self-explanatory without requiring any cross reference with the text or other tables.



Mnemonic	Symbolic Operation	Flags						Op-Code			No. of Bytes	No. of M Cycles	No. of T Cycles	Comments
		C	Z	P/V	S	N	H	76	543	210				
LD r, r'	r ← r'	*	*	*	*	*	*	01	r'	r	2	1	4	r, r' Reg.
LD r, #	r ← #	*	*	*	*	*	*	00	#	110	2	2	7	000 B
LD r, (HL)	r ← (HL)	*	*	*	*	*	*	01	r	110	2	2	7	001 C
LD r, (X+d)	r ← (X+d)	*	*	*	*	*	*	11	011	101	3	5	19	010 D
								01	r	110				100 H
								-	d	-				101 L
LD r, (Y+d)	r ← (Y+d)	*	*	*	*	*	*	11	121	101	3	5	19	111 A
								01	r	110				
								-	d	-				
LD (HL), r	(HL) ← r	*	*	*	*	*	*	01	110	r	2	2	7	
LD (X+d), r	(X+d) ← r	*	*	*	*	*	*	11	011	101	3	5	19	
								01	110	r				
								-	d	-				
LD (Y+d), r	(Y+d) ← r	*	*	*	*	*	*	11	111	101	3	5	19	
								01	110	r				
								-	d	-				
LD (HL), #	(HL) ← #	*	*	*	*	*	*	00	110	110	2	3	10	
								-	#	-				
LD (X+d), #	(X+d) ← #	*	*	*	*	*	*	11	011	101	4	5	19	
								00	110	110				
								-	d	-				
								-	#	-				
LD (Y+d), #	(Y+d) ← #	*	*	*	*	*	*	11	111	101	4	5	19	
								00	110	110				
								-	#	-				
								-	#	-				
LD A, (BC)	A ← (BC)	*	*	*	*	*	*	00	001	010	2	2	7	
LD A, (DE)	A ← (DE)	*	*	*	*	*	*	00	011	010	2	2	7	
LD A, (nn)	A ← (nn)	*	*	*	*	*	*	00	111	010	3	4	13	
								-	#	-				
								-	#	-				
LD (BC), A	(BC) ← A	*	*	*	*	*	*	00	000	010	1	2	7	
LD (DE), A	(DE) ← A	*	*	*	*	*	*	00	010	010	1	2	7	
LD (nn), A	(nn) ← A	*	*	*	*	*	*	00	110	010	3	4	13	
								-	#	-				
								-	#	-				
LD A, I	A ← I	*	1	IFF	1	0	0	11	101	101	2	2	9	
								01	010	111				
LD A, R	A ← R	*	1	IFF	1	0	0	11	101	101	2	2	9	
								01	011	111				
LD I, A	I ← A	*	*	*	*	*	*	11	101	101	2	2	9	
								01	000	111				
LD R, A	R ← A	*	*	*	*	*	*	11	101	101	2	2	9	
								01	001	111				

Note: r, r' means any of the registers A, B, C, D, E, H, L

IFF the contents of the interrupt enable flip-flop (IFF) is copied into the P/V flag

Flag Notation: * = flag not affected, 0 = flag reset, 1 = flag set, # = flag is address

1 = flag is affected according to the result of the operation



Mnemonic	Symbolic Operation	Flags					Op. Code			No. of Bytes	No. of M Cycles	No. of T States	Comments
		C	Z	N	V	H	76	543	310				
LD 40, 00	40 ← 00	00	400	000	3	3	10	00 00 00 00
LD IX, 00	IX ← 00	12	011	101	4	4	14	10 10 11
LD IV, 00	IV ← 00	11	131	101	4	4	14	
LD XI, (00)	H ← (00+1) L ← (00)	00	101	010	3	3	14	
LD AI, (00)	40 _H ← (00+1) 40 _L ← (00)	12	101	101	4	4	20	
LD XI, (00)	IX _H ← (00+1) IX _L ← (00)	11	011	101	4	4	20	
LD IV, (00)	IV _H ← (00+1) IV _L ← (00)	11	131	101	4	4	20	
LD (00), HL	(00+1) ← H (00) ← L	00	100	010	3	3	14	
LD (00), 40	(00+1) ← 40 _H (00) ← 40 _L	11	101	101	4	4	20	
LD (00), IX	(00+1) ← IX _H (00) ← IX _L	11	011	101	4	4	20	
LD (00), IV	(00+1) ← IV _H (00) ← IV _L	12	111	101	4	4	20	
LD SP, HL	SP ← HL	11	111	001	3	3	6	
LD SP, IX	SP ← IX	11	011	101	3	3	6	
LD SP, IV	SP ← IV	11	131	001	3	3	6	
PUSH 00	(SP-1) ← 00 _H (SP-2) ← 00 _L	11	000	101	3	3	10	00 00
PUSH IX	(SP-1) ← IX _H (SP-2) ← IX _L	12	011	101	3	3	10	10 10 11
PUSH IV	(SP-1) ← IV _H (SP-2) ← IV _L	12	111	101	3	3	10	
POP 00	00 _H ← (SP+1) 00 _L ← (SP)	11	000	001	3	3	10	
POP IX	IX _H ← (SP+1) IX _L ← (SP)	11	011	101	3	3	10	
POP IV	IV _H ← (SP+1) IV _L ← (SP)	11	111	101	3	3	10	

Notes: All flags of the system pair HL, DE, HL, SP are in any of the register pairs AF, HL, IX, HL (PAIR), DE, HL, SP (PAIR) or HL, SP (PAIR) - unless both bits of the register pair respectively (PAIR) are affected. E.g. HL ← C, AF ← A

Flag Notations: . - Flag not affected, 0 - flag cleared, 1 - flag set, X - flag is either 0 or 1.
1 - flag is affected according to the result of the operation.

Mnemonic	Symbolic Operation	Flag						Op. Code			No. of Bytes	No. of M Cycles	No. of T States	Comments
		C	Z	V	S	N	H	76	543	210				
EX DE, HL	DE ← HL	11	101	011	1	1	4	
EX AF, AF'	AF ← AF'	00	001	000	1	1	4	
EXR	(BC) ← (DE) (DE) ← (BC)	11	011	001	1	1	4	Register bank and auxiliary register bank exchange
EX (SP), HL	H ← (SP+1) L ← (SP)	11	100	011	1	5	18	
EX (SP), IX	IX _H ← (SP+1) IX _L ← (SP)	11	011	101	2	6	23	
EX (SP), IY	IY _H ← (SP+1) IY _L ← (SP)	11	111	101	2	6	23	
LDI	(DE) ← (HL) DE ← DE+1 HL ← HL-1 BC ← BC-1	.	.	①	.	U	0	11	101	101	2	4	16	Load (HL) into (DE), increment the pointers and decrement the byte counter (BC)
LDIR	(DE) ← (HL) DE ← DE+1 HL ← HL+1 BC ← BC-1 Repeat until BC = 0	.	.	0	.	0	0	11	101	101	2	5	21	If BC = 0
				①				10	110	000	2	4	16	If BC = 0
LXI	(DE) ← (HL) DE ← DE-1 HL ← HL-1 BC ← BC-1	.	.	1	.	0	0	11	101	101	2	4	16	
LDIR	(DE) ← (HL) DE ← DE-1 HL ← HL-1 BC ← BC-1 Repeat until BC = 0	.	.	0	.	0	0	11	101	101	2	5	21	If BC = 0
				①				10	111	000	2	4	16	If BC = 0
CPI	A ← (HL) HL ← HL+1 BC ← BC-1	.	②	①	.	.	.	11	101	101	2	4	16	
CPH	A ← (HL) HL ← HL+1 BC ← BC-1 Repeat until A = (HL) or BC = 0	.	②	①	.	.	.	11	101	101	2	5	21	If BC = 0 and A = (HL)
				①				10	110	001	2	4	16	If BC = 0 or A = (HL)
CPD	A ← (HL) HL ← HL+1 BC ← BC-1	.	②	①	.	.	.	11	101	101	2	4	16	
CPDR	A ← (HL) HL ← HL+1 BC ← BC-1 Repeat until A = (HL) or BC = 0	.	②	①	.	.	.	11	101	101	2	5	21	If BC = 0 and A = (HL)
				①				10	111	001	2	4	16	If BC = 0 or A = (HL)

Notes: ① P, V flag = 0 if the result of (BC) = 0, otherwise P, V = 1

② Z flag = 1 if A = (HL), otherwise Z = 0

Flag Notation: . = flag not affected, 0 = flag reset, 1 = flag set, 2 = flag is unknown,

U = flag is affected according to the result of the operation.

EXCHANGE GROUP AND BLOCK TRANSFER AND SEARCH GROUP

TABLE 2.0-3

Mnemonic	Symbolic Operation	Flags						Op Code				No. of Bytes	No. of M. Cycles	No. of T. States	Comments
		C	Z	P	V	S	H	7b	543	210					
ADD A, r	A ← A + r	1	1	V	1	0	1	10	000	r	1	1	4	r 000 B 001 C 010 D 011 E 100 H 101 L 111 A	
ADD A, n	A ← A + n	1	1	V	1	0	1	11	000	110	2	2	7		
ADD A, (HL)	A ← A + (HL)	1	1	V	1	0	1	10	000	110	1	2	7		
ADD A, (IX+d)	A ← A + (IX+d)	1	1	V	1	0	1	11	011	101	3	5	19		
								10	000	110					
ADD A, (IY+d)	A ← A + (IY+d)	1	1	V	1	0	1	11	111	101	3	5	19		
								10	000	110					
ADC A, s	A ← A + s + CY	1	1	V	1	0	1		001					s is any of r, n, (HL), (IX+d), (IY+d) as shown for ADD instruction.	
SUB s	A ← A - s	1	1	V	1	1	1		010						
SBC A, s	A ← A - s - CY	1	1	V	1	1	1		011						
AND s	A ← A & s	0	1	F	1	0	1		100						
OR s	A ← A s	0	1	F	1	0	0		110					The indicated bits replace the 000 in the ADD set above.	
XOR s	A ← A ⊕ s	0	1	F	1	0	0		101						
CP s	A ← s	1	1	V	1	1	1		111						
JNC r	r ← r + 1	+	1	V	1	0	1	00	r	100	1	1	4		
INC (HL)	(HL) ← (HL) + 1	+	1	V	1	0	1	00	110	100	1	3	11		
INC (IX+d)	(IX+d) ← (IX+d) + 1	+	1	V	1	0	1	11	011	101	3	6	23		
								00	110	100					
INC (IY+d)	(IY+d) ← (IY+d) + 1	+	1	V	1	0	1	11	111	101	3	6	23		
								00	110	100					
DEC m	m ← m - 1	+	1	V	1	1	1		101					m is any of r, (HL), (IX+d), (IY+d) as shown for INC. Some format and states as INC. Replace 100 with 101 in OP code.	

Notes: The V symbol in the P/V flag column indicates that the P/V flag contains the overflow of the result of the operation. Similarly the P symbol indicates parity. V = 1 means overflow, V = 0 means not overflow, P = 1 means parity of the result is even, P = 0 means parity of the result is odd.

Flag Notation: + = flag not affected, 0 = flag reset, 1 = flag set, X = flag is unknown, | = flag is affected according to the result of the operation.

8 BIT ARITHMETIC AND LOGICAL GROUP
TABLE 7.04

Mnemonic	Symbolic Operation	Flags						Op-Code			No. of Bytes	No. of M Cycles	No. of T States	Comments
		C	Z	V	S	N	H	7a	543	210				
DAA	Converts acc. content into packed BCD following add or subtract with packed BCD operands	1	1	1	1	1	1	00	100	111	1	1	4	Decimal adjust accumulated
CPL	$A \rightarrow \bar{A}$	1	1	1	1	1	1	00	101	111	1	1	4	Complement accumulation (one's complement)
NEG	$A \rightarrow \bar{A}$	1	1	1	1	1	1	11	101	101	2	2	8	Negate acc. (two's complement)
CCF	$CY \rightarrow \bar{CY}$	1	1	1	1	1	1	00	111	111	1	1	4	Complement carry flag
SCF	$CY \rightarrow 1$	1	1	1	1	1	1	00	110	111	1	1	4	Set carry flag
NOP	No operation	1	1	1	1	1	1	00	000	000	1	1	4	
HALT	CPU halted	1	1	1	1	1	1	01	110	110	1	1	4	
DI	$IFF \rightarrow 0$	1	1	1	1	1	1	11	110	011	1	1	4	
EI	$IFF \rightarrow 1$	1	1	1	1	1	1	11	111	011	1	1	4	
IM0	Set interrupt mode 0	1	1	1	1	1	1	11	101	101	2	2	8	
IM1	Set interrupt mode 1	1	1	1	1	1	1	11	101	101	2	2	8	
IM2	Set interrupt mode 2	1	1	1	1	1	1	01	010	110	2	2	8	
								01	011	110				

Notes: IFF indicates the interrupt enable flip-flop.
CY indicates the carry flip-flop.

Flag Notation: 1 = flag not affected, 0 = flag reset, 1 = flag set, X = flag is unknown, 1 = flag is affected according to the result of the operation.

GENERAL PURPOSE ARITHMETIC AND CPU CONTROL GROUPS
TABLE 7.0-5

Mnemonic	Symbolic Operation	Flags						Op-Code			No. of Bytes	No. of M. Cycles	No. of T States	Comments			
		C	Z	V	S	N	H	74	343	310							
ADD HL, m	HL ← HL + m	1	•	•	•	0	X	00	xx1	001	1	3	11	m Reg.			
ADC HL, w	HL ← HL + w + CY	1	V	1	0	X	11	101	101	01	m1	010	2	4	15	BC DE HL SP	
SBC HL, w	HL ← HL - w - CY	1	1	V	1	1	X	11	101	101	01	w0	010	2	4	15	
ADD IX, pp	IX ← IX + pp	1	•	•	•	0	X	11	011	101	00	pp1	001	2	4	15	pp Reg. BC DE IX SP
ADD IY, rr	IY ← IY + rr	1	•	•	•	0	X	11	111	101	00	rr1	001	2	4	15	rr Reg. BC DE IY SP
INC m	m ← m + 1	•	•	•	•	•	•	00	xx0	011	1	1	6				
INC IX	IX ← IX + 1	•	•	•	•	•	•	11	011	101	00	100	011	2	2	10	
INC IY	IY ← IY + 1	•	•	•	•	•	•	11	111	101	00	100	011	2	2	10	
DEC m	m ← m - 1	•	•	•	•	•	•	00	xx1	011	1	1	6				
DEC IX	IX ← IX - 1	•	•	•	•	•	•	11	011	101	00	101	011	2	2	10	
DEC IY	IY ← IY - 1	•	•	•	•	•	•	11	111	101	00	101	011	2	2	10	

Notes: m is any of the register pairs BC, DE, HL, SP
 pp is any of the register pairs BC, DE, IX, SP
 rr is any of the register pairs BC, DE, IY, SP.

Flag Notation: • = flag not affected, 0 = flag reset, 1 = flag set, X = flag unknown, 2 = flag is affected according to the result of the operation.

16-BIT ARITHMETIC GROUP
 TABLE 7.0-6

Mnemonic	Symbolic Operation	Flag					Op-Code			No. of Bytes	No. of M Cycles	No. of T States	Comments	
		C	Z	P	S	N	H	76	543					210
RLCA		1	+	-	0	0	00	000	111	1	1	4	Rotate left circular accumulator	
RLA		1	+	-	0	0	00	010	111	1	1	4	Rotate left accumulator	
RRCa		1	-	-	0	0	00	001	111	1	1	4	Rotate right circular accumulator	
RRA		1	-	-	0	0	00	011	111	1	1	4	Rotate right accumulator	
RLC _r		1	1	1	0	0	11	001	011	2	2	8	Rotate left circular register	
RLC(01)		1	1	1	0	0	11	001	011	2	4	15	Instruction format and states are as shown for RLC _m . To form op. OP-code replace 000 of RLC _m with shown code	
RLC(IX+d)		1	1	1	0	0	11	011	101	4	6	23		
		1	1	1	0	0	11	001	011					
		1	1	1	0	0	11	111	101	4	6	23		
		1	1	1	0	0	11	001	011					
RLC(1Y+d)		1	1	1	0	0	11	111	101	4	6	23		
RL _m		1	1	1	0	0		010					Instruction format and states are as shown for RLC _m . To form op. OP-code replace 000 of RLC _m with shown code	
RRC _m		1	1	1	0	0		001						
RR _m		1	1	1	0	0		011						
SLA _m		1	1	1	0	0		100						
SRA _m		1	1	1	0	0		101						
SRL _m		1	1	1	0	0		111						
RLD		1	1	1	0	0	11	101	101	2	5	18		Rotate digit left and right between the accumulator and location (HL). The content of the upper half of the accumulator is unaffected
RRD		1	1	1	0	0	11	101	101	2	5	18		

Flag Notation: + = flag not affected, 0 = flag reset, 1 = flag set, X = flag is unknown, - = flag is affected according to the result of the operation.

ROTATE AND SHIFT GROUP

TABLE 7.0-7

Mnemonic	Symbolic Operation	Flags						Op-Code			No. of Bytes	No. of M Cycles	No. of T States	Comments	
		C	Z	V	S	N	H	76	543	210					
BIT b, r	$Z \leftarrow \overline{b}_r$	*	1	X	X	0	1	11	001	011	2	2	8	r	Reg.
								01	b	r				000	B
BIT b, (HL)	$Z \leftarrow \overline{(HL)}_b$	*	1	X	X	0	1	11	001	011	2	3	12	001	C
								01	b	110				010	D
BIT b, (IX+d)	$Z \leftarrow \overline{(IX+d)}_b$	*	1	X	X	0	1	11	011	101	4	5	20	011	E
								11	001	011				100	H
								-	d	-				101	L
								-	d	-				111	A
BIT b, (IY+d)	$Z \leftarrow \overline{(IY+d)}_b$	*	1	X	X	0	1	11	111	101	4	5	20	b	Bit Tested
								01	b	110				000	0
								11	001	011				001	1
								-	d	-				010	2
								01	b	110				011	3
														100	4
														101	5
														110	6
														111	7
SET b, r	$b_r \leftarrow 1$	*	*	*	*	*	*	11	001	011	2	2	8		
SET b, (HL)	$(HL)_b \leftarrow 1$	*	*	*	*	*	*	11	001	011	2	4	15		
SET b, (IX+d)	$(IX+d)_b \leftarrow 1$	*	*	*	*	*	*	11	011	101	4	6	23		
								11	001	011					
								-	d	-					
SET b, (IY+d)	$(IY+d)_b \leftarrow 1$	*	*	*	*	*	*	11	111	101	4	6	23		
								11	001	011					
								-	d	-					
								11	b	110					
RES b, m	$b_r \leftarrow 0$ $m = r, (HL),$ $(IX+d),$ $(IY+d)$	*	*	*	*	*	*	10							

To form new OP-
code replace **11**
of SET b,r with
10. Flags and time
states for SET
instruction

Notes: The notation b_r indicates bit b (0 to 7) or location r.

Flag Notation: * = flag not affected, 0 = flag reset, 1 = flag set, X = flag is unknown,
1 = flag is affected according to the result of the operation.

BIT SET, RESET AND TEST GROUP
TABLE 7.08

Mnemonic	Symbolic Operation	Flag						Op-Code			No. of Bytes	No. of M Cycles	No. of T States	Comments
		C	Z	V	S	N	H	76	543	210				
JP aa	PC ← aa	*	*	*	*	*	*	31	000	031	3	3	10	
JP cc, aa	If condition cc is true PC ← aa, otherwise continue	*	*	*	*	*	*	11	cc	010	3	3	10	cc
		000	NZ non zero											
		001	Z zero											
		010	NC non carry											
		011	C carry											
JR a	PC ← PC + a	*	*	*	*	*	*	00	011	000	2	3	12	
		-a-2												
JR C, a	If C = 0, continue	*	*	*	*	*	*	00	111	000	2	3	7	If condition not met
		-a-2												
JR NC, a	If C = 1, continue	*	*	*	*	*	*	00	110	000	2	3	7	If condition not met
		-a-2												
JR Z, a	If Z = 0, continue	*	*	*	*	*	*	00	101	000	2	3	12	If condition is met
		-a-2												
JR NZ, a	If Z = 1, continue	*	*	*	*	*	*	00	100	000	2	3	7	If condition not met
		-a-2												
JR NZ, a	If Z = 0, continue	*	*	*	*	*	*	00	100	000	2	3	12	If condition met
		-a-2												
JP (HL)	PC ← HL	*	*	*	*	*	*	11	101	001	1	1	4	
JP (IX)	PC ← IX	*	*	*	*	*	*	11	011	101	2	3	8	
		11	101	001										
JP (IY)	PC ← IY	*	*	*	*	*	*	31	111	101	2	3	8	
		11	101	001										
DJNZ a	B ← B - 1	*	*	*	*	*	*	00	010	000	2	2	8	If B = 0
	If B = 0, continue							-a-2						
	If B = 0, PC ← PC + a										2	3	13	If B = 0

Notes: a represents the extension in the relative addressing mode.
 a is a signed two's complement number in the range <-128, 127>
 a-2 in the op-code provides an effective address of pc + a as PC is incremented by 2 prior to the addition of a.

Flag Notation: * = flag not affected, 0 = flag reset, 1 = flag set, X = flag is unknown,
 † = flag is affected according to the result of the operation

JUMP GROUP
 TABLE 7.0.9

Mnemonic	Symbolic Operation	Flags						Op-Code			No. of Bytes	No. of M Cycles	No. of T States	Comments
		C	Z	V	S	N	H	76	543	210				
CALL <i>nn</i>	$(SP-1) \rightarrow PC_H$ $(SP-2) \rightarrow PC_L$ $PC \rightarrow nn$	*	*	*	*	*	*	11	001	101	3	5	12	
		-	-	-	-	-	-	-	-	-				
		-	-	-	-	-	-	-	-	-				
CALL <i>cc, nn</i>	If condition <i>cc</i> is false continue, otherwise same as CALL <i>nn</i>	*	*	*	*	*	*	11	<i>cc</i>	100	3	3	10	If <i>cc</i> is false
		*	*	*	*	*	*	-	-	-	3	5	17	If <i>cc</i> is true
RET	$PC_L \leftarrow (SP)$ $PC_H \leftarrow (SP+1)$	*	*	*	*	*	*	11	001	001	1	3	10	
RET <i>cc</i>	If condition <i>cc</i> is false continue, otherwise same as RET	*	*	*	*	*	*	11	<i>cc</i>	000	1	1	3	If <i>cc</i> is false
		*	*	*	*	*	*				1	3	11	If <i>cc</i> is true
RETI	Return from interrupt	*	*	*	*	*	*	11	101	101	2	4	14	
RETN	Return from non maskable interrupt	*	*	*	*	*	*	11	101	101	2	4	14	
		*	*	*	*	*	*	01	000	101				
RST <i>p</i>	$(SP-1) \rightarrow PC_H$ $(SP-2) \rightarrow PC_L$ $PC_H \leftarrow 0$ $PC_L \leftarrow p$	*	*	*	*	*	*	11	1	111	1	3	11	

cc	Condition
000	NZ non zero
001	Z zero
010	NC non carry
011	C carry
100	PO parity odd
101	PE parity even
110	P sign positive
111	M sign negative

C	F
000	00H
001	08H
010	10H
011	18H
100	20H
101	28H
110	30H
111	38H

Flag Notation: * = flag not affected, 0 = flag reset, 1 = flag set, X = flag unknown
 † = flag is affected according to the result of the operation.

CALL AND RETURN, OSCUP
 TABLE 7.0-10

Mnemonic	Symbolic Operation	Flags						Op-Code				No. of Bytes	No. of M Cycles	No. of T States	Comments
		C	Z	S	N	H	76	543	220						
IN A, (n)	A ← (n)	11	011	011	2	3	11	n to A ₀ - A ₇ Acc to A ₈ - A ₁₅	
IN X, (C)	X ← (C) if x = 110 only the flags will be affected	.	1	P	1	0	.	11	101	101	2	3	12	C to A ₀ - A ₇ B to A ₈ - A ₁₅	
INT	(HL) ← (C) B ← B - 1 HL ← HL + 1	X	1	X	X	1	X	11	101	101	2	4	16	C to A ₀ - A ₇ B to A ₈ - A ₁₅	
INIR	(HL) ← (C) B ← B - 1 HL ← HL + 1 Repeat until B = 0	X	1	X	X	1	X	11	101	101	2	5 (if B = 0)	21	C to A ₀ - A ₇ B to A ₈ - A ₁₅	
IND	(HL) ← (C) B ← B - 1 HL ← HL - 1	X	1	X	X	1	X	11	101	101	2	4	16	C to A ₀ - A ₇ B to A ₈ - A ₁₅	
INDR	(HL) ← (C) B ← B - 1 HL ← HL - 1 Repeat until B = 0	X	1	X	X	1	X	11	101	101	2	5 (if B = 0)	21	C to A ₀ - A ₇ B to A ₈ - A ₁₅	
OUT (n), A	(n) → A	11	010	011	2	3	11	n to A ₀ - A ₇ Acc to A ₈ - A ₁₅	
OUT (C), r	(C) → r	11	101	101	2	3	12	C to A ₀ - A ₇ B to A ₈ - A ₁₅	
OUTI	(C) → (HL) B ← B - 1 HL ← HL + 1	X	1	X	X	1	X	11	101	101	2	4	16	C to A ₀ - A ₇ B to A ₈ - A ₁₅	
OTIR	(C) → (HL) B ← B - 1 HL ← HL + 1 Repeat until B = 0	X	1	X	X	1	X	11	101	101	2	5 (if B = 0)	21	C to A ₀ - A ₇ B to A ₈ - A ₁₅	
OUTD	(C) → (HL) B ← B - 1 HL ← HL - 1	X	1	X	X	1	X	11	101	101	2	4	16	C to A ₀ - A ₇ B to A ₈ - A ₁₅	
OTDR	(C) → (HL) B ← B - 1 HL ← HL - 1 Repeat until B = 0	X	1	X	X	1	X	11	101	101	2	5 (if B = 0)	21	C to A ₀ - A ₇ B to A ₈ - A ₁₅	

Notes: ① If the result of B - 1 is zero the Z flag is set, otherwise it is reset.

Flag Notation: . = flag not affected, 0 = flag reset, 1 = flag set, X = flag is unknown, 1* = flag is affected according to the result of the operation.

INPUT AND OUTPUT GROUP
TABLE 7.0-11

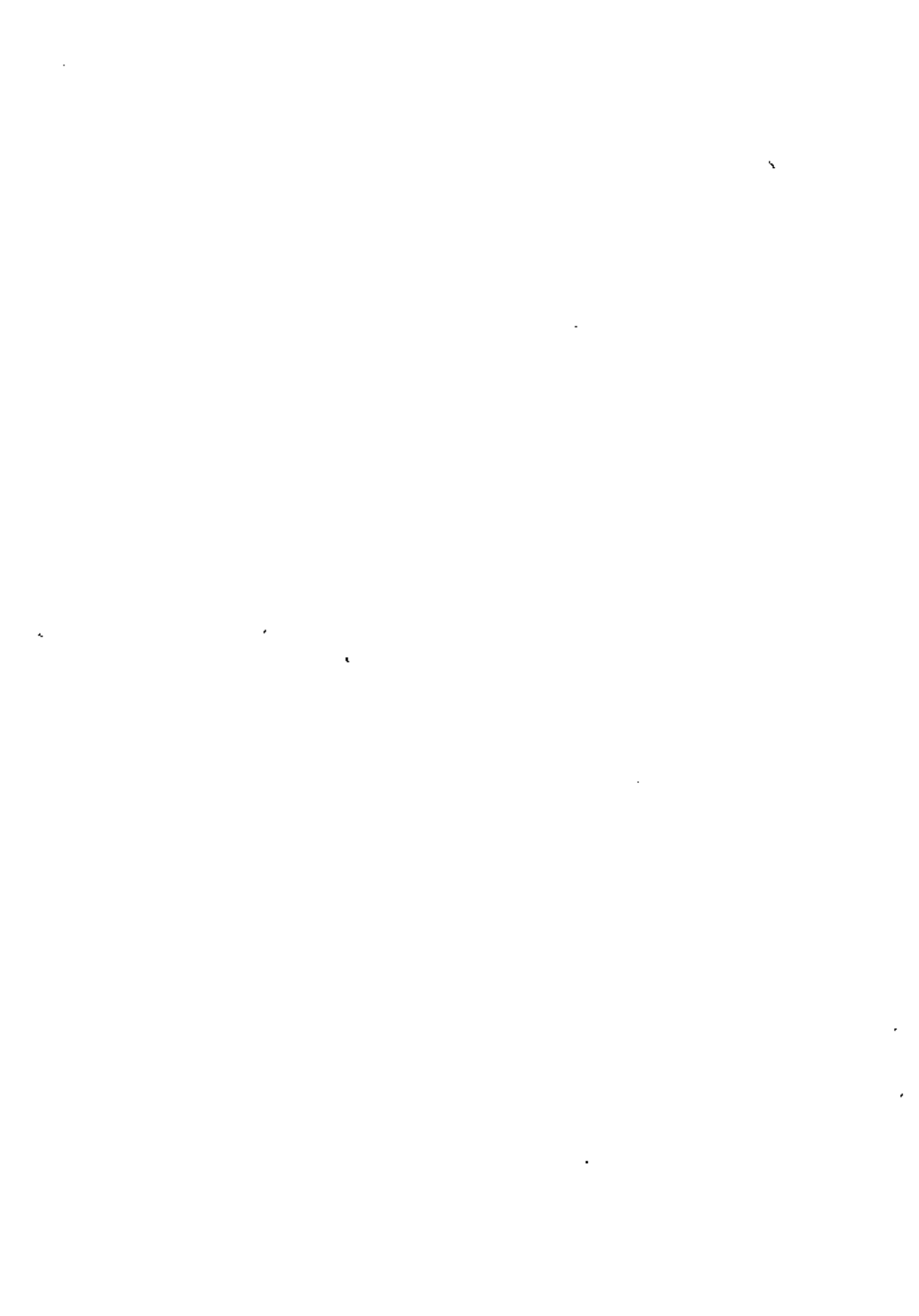

8.0 INTERRUPT RESPONSE

The purpose of an interrupt is to allow peripheral devices to suspend CPU operation in an orderly manner and force the CPU to start a peripheral service routine. Usually this service routine is involved with the exchange of data, or status and control information, between the CPU and the peripheral. Once the service routine is completed, the CPU returns to the operation from which it was interrupted.

INTERRUPT ENABLE - DISABLE

The Z80 CPU has two interrupt inputs, a software maskable interrupt and a non maskable interrupt. The non maskable interrupt (NMI) can *not* be disabled by the programmer and it will be accepted whenever a peripheral device requests it. This interrupt is generally reserved for very important functions that must be serviced whenever they occur, such as an impending power failure. The maskable interrupt (INT) can be selectively enabled or disabled by the programmer. This allows the programmer to disable the interrupt during periods where his program has timing constraints that do not allow it to be interrupted. In the Z80 CPU there is an enable flip flop (called IFF) that is set or reset by the programmer using the Enable Interrupt (EI) and Disable Interrupt (DI) instructions. When the IFF is reset, an interrupt can not be accepted by the CPU.

Actually, for purposes that will be subsequently explained, there are two enable flip flops, called IFF₁ and IFF₂.

IFF₁

Actually disables interrupts
from being accepted.

IFF₂

Temporary storage location
for IFF₁.

The state of IFF₁ is used to actually inhibit interrupts while IFF₂ is used as a temporary storage location for IFF₁. The purpose of storing the IFF₁ will be subsequently explained.

A reset to the CPU will force both IFF₁ and IFF₂ to the reset state so that interrupts are disabled. They can then be enabled by an EI instruction at any time by the programmer. When an EI instruction is executed, any pending interrupt request will not be accepted until after the instruction following EI has been executed. This single instruction delay is necessary for cases when the following instruction is a return instruction and interrupts must not be allowed until the return has been completed. The EI instruction sets both IFF₁ and IFF₂ to the enable state. When an interrupt is accepted by the CPU, both IFF₁ and IFF₂ are automatically reset, inhibiting further interrupts until the programmer wishes to issue a new EI instruction. Note that for all of the previous cases, IFF₁ and IFF₂ are always equal.

The purpose of IFF₂ is to save the status of IFF₁ when a non maskable interrupt occurs. When a non maskable interrupt is accepted, IFF₁ is reset to prevent further interrupts until reenabled by the programmer. Thus, after a non maskable interrupt has been accepted, maskable interrupts are disabled but the previous state of IFF₁ has been saved so that the complete state of the CPU just prior to the non maskable interrupt can be restored at any time. When a Load Register A with Register I (LDA, I) instruction or a Load Register A with Register R (LDA, R) instruction is executed, the state of IFF₂ is copied into the parity flag where it can be tested or stored.

A second method of restoring the status of IFF₁ is thru the execution of a Return From Non Maskable Interrupt (RETN) instruction. Since this instruction indicates that the non maskable interrupt service routine is complete, the contents of IFF₂ are now copied back into IFF₁, so that the status of IFF₁ just prior to the acceptance of the non maskable interrupt will be restored automatically.

Figure 8.0-1 is a summary of the effect of different instructions on the two enable flip flops.

Action	IFF ₁	IFF ₂	
CPU Reset	0	0	
DI	0	0	
EI	1	1	
LD A, I	.	.	IFF ₂ → Parity flag
LD A, R	.	.	IFF ₂ → Parity flag
Accept NMI	0	.	
RETN	IFF ₂	.	IFF ₂ → IFF ₁

"." indicates no change

FIGURE 8.0-1
INTERRUPT ENABLE/DISABLE FLIP FLOPS

CPU RESPONSE

Non Maskable

A nonmaskable interrupt will be accepted at all times by the CPU. When this occurs, the CPU ignores the next instruction that it fetches and instead does a restart to location 0066H. Thus, it behaves exactly as if it had received a restart instruction but, it is to a location that is not one of the 8 software restart locations. A restart is merely a call to a specific address in page 0 of memory.

Maskable

The CPU can be programmed to respond to the maskable interrupt in any one of three possible modes.

Mode 0

This mode is identical to the 8080A interrupt response mode. With this mode, the interrupting device can place any instruction on the data bus and the CPU will execute it. Thus, the interrupting device provides the next instruction to be executed instead of the memory. Often this will be a restart instruction since the interrupting device only need supply a single byte instruction. Alternatively, any other instruction such as a 3 byte call to any location in memory could be executed.

The number of clock cycles necessary to execute this instruction is 2 more than the normal number for the instruction. This occurs since the CPU automatically adds 2 wait states to an interrupt response cycle to allow sufficient time to implement an external daisy chain for priority control. Section 5.0 illustrates the detailed timing for an interrupt response. After the application of RESET the CPU will automatically enter interrupt Mode 0.

Mode 1

When this mode has been selected by the programmer, the CPU will respond to an interrupt by executing a restart to location 0036H. Thus the response is identical to that for a non maskable interrupt except that the call location is 0036H instead of 0066H. Another difference is that the number of cycles required to complete the restart instruction is 2 more than normal due to the two added wait states.

Mode 2

This mode is the most powerful interrupt response mode. With a single 8 bit byte from the user an indirect call can be made to any memory location.

With this mode the programmer maintains a table of 16 bit starting addresses for every interrupt service routine. This table may be located anywhere in memory. When an interrupt is accepted, a 16 bit pointer must be formed to obtain the desired interrupt service routine starting address from the table. The upper 8 bits of this pointer is formed from the contents of the I register. The I register must have been previously loaded with the desired value by the programmer, i.e. LD I, A. Note that a CPU reset clears the I register so that it is initialized to zero. The lower eight bits of the pointer must be supplied by the interrupting device. Actually, only 7 bits are required from the interrupting device as the least significant bit must be a zero. This is required since the pointer is used to get two adjacent bytes to form a complete 16 bit service routine starting address and the addresses must always start in even locations.

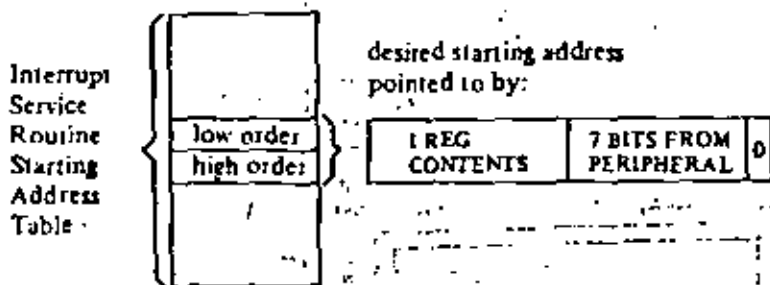

The first byte in the table is the least significant (low order) portion of the address. The programmer must obviously fill this table in with the desired addresses before any interrupts are to be accepted.

Note that this table can be changed at any time by the programmer (if it is stored in Read/Write Memory) to allow different peripherals to be serviced by different service routines.

Once the interrupting device supplies the lower portion of the pointer, the CPU automatically pushes the program counter onto the stack, obtains the starting address from the table and does a jump to this address. This mode of response requires 19 clock periods to complete (7 to fetch the lower 8 bits from the interrupting device, 6 to save the program counter, and 6 to obtain the jump address.)

Note that the Z80 peripheral devices all include a daisy chain priority interrupt structure that automatically supplies the programmed vector to the CPU during interrupt acknowledge. Refer to the Z80-PIO, Z80-SIO and Z80-CTC manuals for details.

9.0 HARDWARE IMPLEMENTATION EXAMPLES

This chapter is intended to serve as a basic introduction to implementing systems with the Z80-CPU.

MINIMUM SYSTEM

Figure 9.0-1 is a diagram of a very simple Z-80 system. Any Z-80 system must include the following five elements:

- 1) Five volt power supply
- 2) Oscillator
- 3) Memory devices
- 4) I/O circuits
- 5) CPU

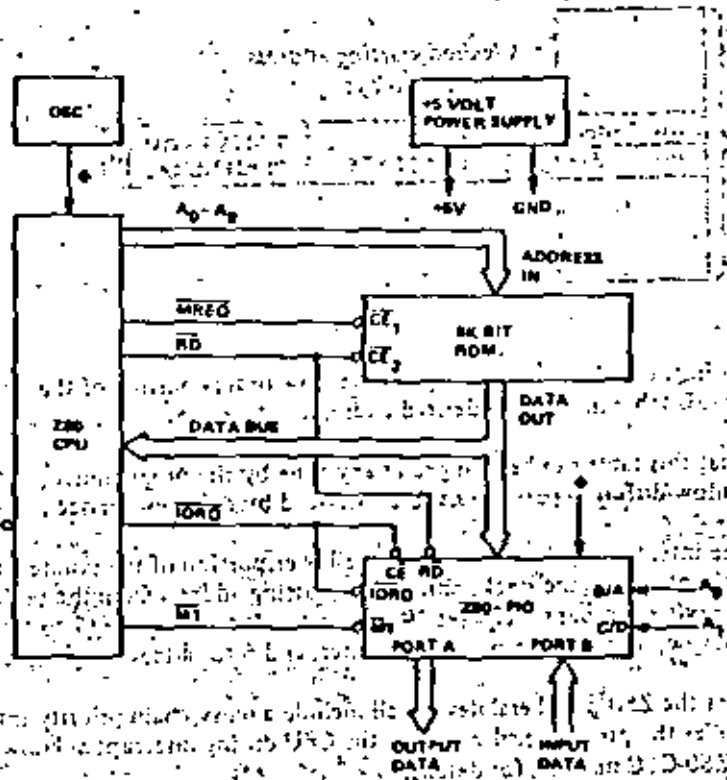

FIGURE 9.0-1
MINIMUM Z80 COMPUTER SYSTEM

Since the Z80-CPU only requires a single 5 volt supply, most small systems can be implemented using only this single supply.

The oscillator can be very simple since the only requirement is that it be a 5 volt square wave. For systems not running at full speed, a simple RC oscillator can be used. When the CPU is operated near the highest possible frequency, a crystal oscillator is generally required because the system timing will not tolerate the drift or jitter that an RC network will generate. A crystal oscillator can be made from inverters and a few discrete components or monolithic circuits are widely available.

The external memory can be any mixture of standard RAM, ROM, or PROM. In this simple example we have shown a single 8K bit ROM (1K bytes) being utilized as the entire memory system. For this example we have assumed that the Z-80 internal register configuration contains sufficient Read/Write storage so that external RAM memory is not required.

Every computer system requires I/O circuits to allow it to interface to the "real world." In this simple example it is assumed that the output is an 8 bit control vector and the input is an 8 bit status word. The input data could be gated onto the data bus using any standard tri-state driver while the output data could be latched with any type of standard TTL latch. For this example we have used a Z80-PIO for the I/O circuit. This single circuit attaches to the data bus as shown and provides the required 16 bits of TTL compatible I/O. (Refer to the Z80-PIO manual for details on the operation of this circuit.) Notice in this example that with only three LSI circuits, a simple oscillator and a single 5 volt power supply, a powerful computer has been implemented.

ADDING RAM

Most computer systems require some amount of external Read/Write memory for data storage and to implement a "stack." Figure 9.0-2 illustrates how 256 bytes of static memory can be added to the previous example. In this example the memory space is assumed to be organized as follows:

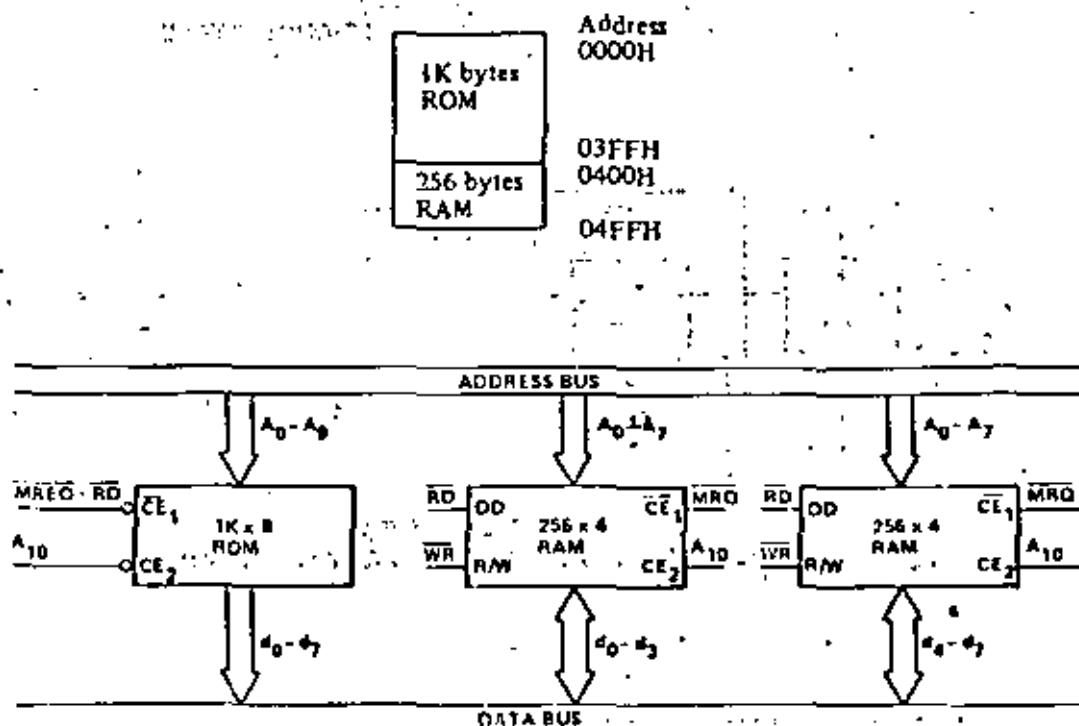

FIGURE 9.0-2
ROM & RAM IMPLEMENTATION EXAMPLE

In this diagram the address space is described in hexadecimal notation. For this example, address bit A₁₀ separates the ROM space from the RAM space so that it can be used for the chip select function. For larger amounts of external ROM or RAM, a simple TTL decoder will be required to form the chip selects.

MEMORY SPEED CONTROL

For many applications, it may be desirable to use slow memories to reduce costs. The WAIT line on the CPU allows the Z-80 to operate with any speed memory. By referring back to section 4 you will notice that the memory access time requirements are most severe during the M1 cycle instruction fetch. All other memory accesses have an additional one half of a clock cycle to be completed. For this reason it may be desirable in some applications to add one wait state to the M1 cycle so that slower memories can be used. Figure 9.0-3 is an example of a simple circuit that will accomplish this task. This circuit can be changed to add a single wait state to any memory access as shown in Figure 9.0-4.

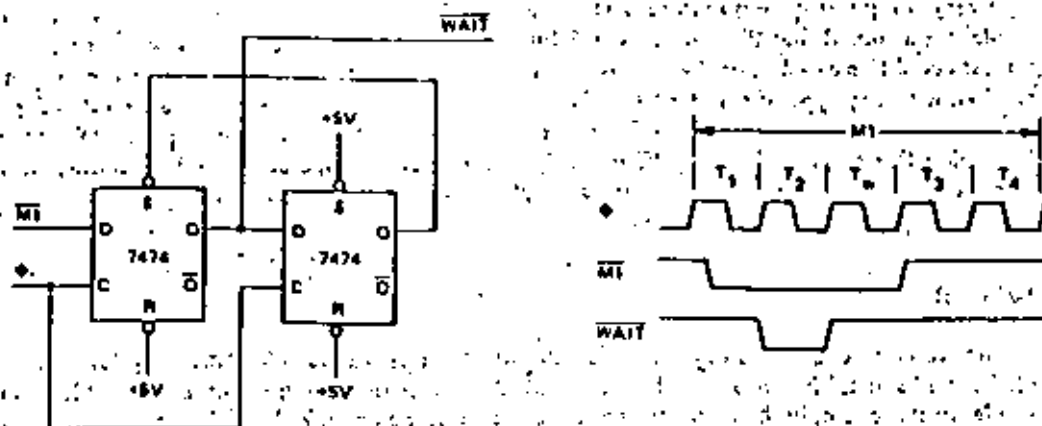

FIGURE 9.0-3
 ADDING ONE WAIT STATE TO AN M1 CYCLE

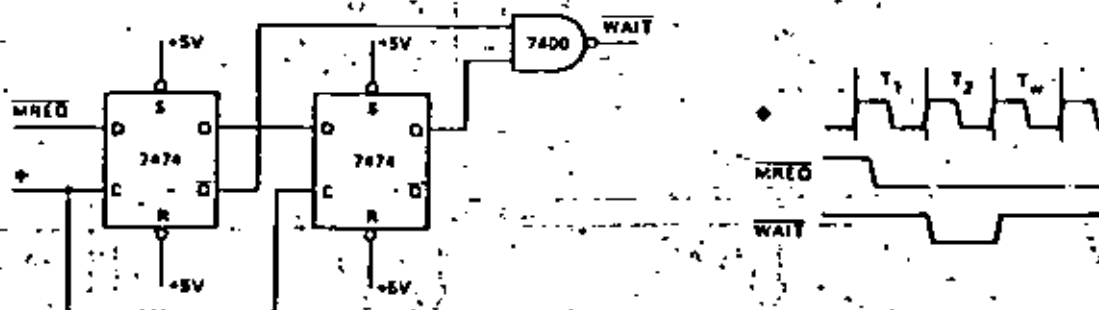

FIGURE 9.0-4
 ADDING ONE WAIT STATE TO ANY MEMORY CYCLE

INTERFACING DYNAMIC MEMORIES

This section is intended only to serve as a brief introduction to interfacing dynamic memories. Each individual dynamic RAM has varying specifications that will require minor modifications to the description given here and no attempt will be made in this document to give details for any particular RAM. Separate application notes showing how the Z80-CPU can be interfaced to most popular dynamic RAM's are available from Zilog.

Figure 9.0-5 illustrates the logic necessary to interface 8K bytes of dynamic RAM using 18 pin 4K dynamic memories. This figure assumes that the RAM's are the only memory in the system so that A_{12} is used to select between the two pages of memory. During refresh time, all memories in the system must be read. The CPU provides the proper refresh address on lines A_0 through A_6 . To add additional memory to the system it is necessary to only replace the two gates that operate on A_{12} with a decoder that operates on all required address bits. For larger systems, buffering for the address and data bus is also generally required.

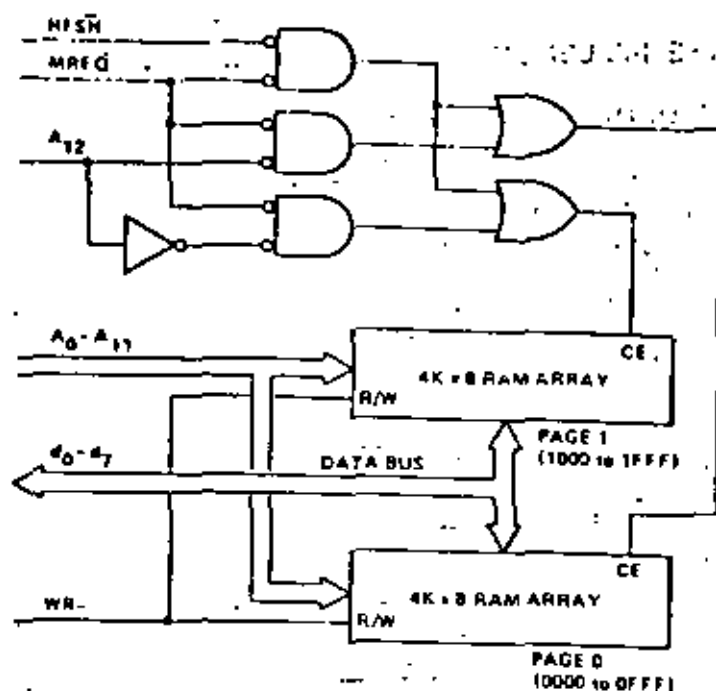

FIGURE 9.0-5
INTERFACING DYNAMIC RAMS

10.0 SOFTWARE IMPLEMENTATION EXAMPLES

10.1 METHODS OF SOFTWARE IMPLEMENTATION

Several different approaches are possible in developing software for the Z-80 (Figure 10.1). First of all, Assembly Language or PL/Z may be used as the source language. These languages may then be translated into machine language on a commercial time sharing facility using a cross-assembler or cross-compiler or, in the case of assembly language, the translation can be accomplished on a Z-80 Development System using a resident assembler. Finally, the resulting machine code can be debugged either on a time-sharing facility using a Z-80 simulator or on a Z-80 Development System which uses a Z80-CPU directly.

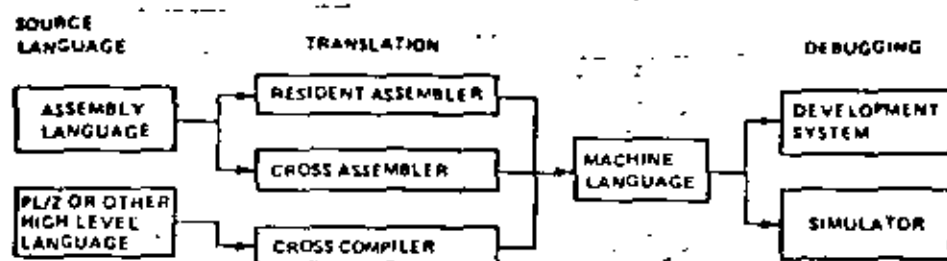

FIGURE 10.1

In selecting a source language, the primary factors to be considered are clarity and ease of programming vs. code efficiency. A high level language such as PL/Z with its machine independent constructs is typically better for formulating and maintaining algorithms, but the resulting machine code is usually somewhat less efficient than what can be written directly in assembly language. These tradeoffs can often be balanced by combining PL/Z and assembly language routines, identifying those portions of a task which must be optimized and writing them as assembly language subroutines.

Deciding whether to use a resident or cross assembler is a matter of availability and short-term vs. long-term expense. While the initial expenditure for a development system is higher than that for a time-sharing terminal, the cost of an individual assembly using a resident assembler is negligible while the same operation on a time-sharing system is relatively expensive and in a short time this cost can equal the total cost of a development system.

Debugging on a development system vs. a simulator is also a matter of availability and expense combined with operational fidelity and flexibility. As with the assembly process, debugging is less expensive on a development system than on a simulator available through time-sharing. In addition, the fidelity of the operating environment is preserved through real-time execution on a Z80-CPU and by connecting the I/O and memory components which will actually be used in the production system. The only advantage to the use of a simulator is the range of criteria which may be selected for such debugging procedures as tracing and setting break points. This flexibility exists because a software simulation can achieve any degree of complexity in its interpretation of machine instructions while development system procedures have hardware limitations such as the capacity of the real-time storage module, the number of break point registers and the pin configuration of the CPU. Despite such hardware limitations, debugging on a development system is typically more productive than on a simulator because of the direct interaction that is possible between the programmer and the authentic execution of his program.

10.2 SOFTWARE FEATURES OFFERED BY THE Z80 CPU

The Z-80 instruction set provides the user with a large and flexible repertoire of operations with which to formulate control of the Z80 CPU.

The primary, auxiliary and index registers can be used to hold the arguments of arithmetic and logical operations, or to form memory addresses, or as fast-access storage for frequently used data.

Information can be moved directly from register to register; from memory to memory; from memory to registers; or from registers to memory. In addition, register contents and register/memory contents can be exchanged without using temporary storage. In particular, the contents of primary and auxiliary registers can be completely exchanged by executing only two instructions, EX and EXX. This register exchange procedure can be used to separate the set of working registers between different logical procedures or to expand the set of available registers in a single procedure.

Storage and retrieval of data between pairs of registers and memory can be controlled on a last-in first-out basis through PUSH and POP instructions which utilize a special stack pointer register, SP. This stack register is available both to manipulate data and to automatically store and retrieve addresses for subroutine linkage. When a subroutine is called, for example, the address following the CALL instruction is placed on the top of the push-down stack pointed to by SP. When a subroutine returns to the calling routine, the address on the top of the stack is used to set the program counter for the address of the next instruction. The stack pointer is adjusted automatically to reflect the current "top" stack position during PUSH, POP, CALL and RET instructions. This stack mechanism allows pushdown data stacks and subroutine calls to be nested to any practical depth because the stack area can potentially be as large as memory space.

The sequence of instruction execution can be controlled by six different flags (carry, zero, sign, parity/overflow, add/subtract, half-carry) which reflect the results of arithmetic, logical, shift and compare instructions. After the execution of an instruction which sets a flag, that flag can be used to control a conditional jump or return instruction. These instructions provide logical control following the manipulation of single bit, eight-bit byte (or) sixteen-bit data quantities.

A full set of logical operations, including AND, OR, XOR (exclusive - OR), CPU (NOR) and NEG (two's complement) are available for Boolean operations between the accumulator and 1) all other eight-bit registers, 2) memory locations or 3) immediate operands.

In addition, a full set of arithmetic and logical shifts in both directions are available which operate on the contents of all eight-bit primary registers or directly on any memory location. The carry flag can be included or simply set by these shift instructions to provide both the testing of shift results and to link register/register or register/memory shift operations.

10.3 EXAMPLES OF USE OF SPECIAL Z80 INSTRUCTIONS

- A. Let us assume that a string of data in memory starting at location "DATA" is to be moved into another area of memory starting at location "BUFFER" and that the string length is 737 bytes. This operation can be accomplished as follows:

```
LD     HL, DATA      ; START ADDRESS OF DATA STRING
LD     DE, BUFFER     ; START ADDRESS OF TARGET BUFFER
LD     BC, 737        ; LENGTH OF DATA STRING
LDIR   ; MOVE STRING - TRANSFER MEMORY POINTED TO
        ; BY HL INTO MEMORY LOCATION POINTED TO BY DE
        ; INCREMENT HL AND DE, DECREMENT BC
        ; PROCESS UNTIL BC = 0.
```

11 bytes are required for this operation and each byte of data is moved in 21 clock cycles.

- B. Let's assume that a string in memory starting at location "DATA" is to be moved into another area of memory starting at location "BUFFER" until an ASCII '\$' character (used as string delimiter) is found. Let's also assume that the maximum string length is 132 characters. The operation can be performed as follows:

```

LD      HL, DATA      ; STARTING ADDRESS OF DATA STRING
LD      DE, BUFFER     ; STARTING ADDRESS OF TARGET BUFFER
LD      BC, 132        ; MAXIMUM STRING LENGTH
LD      A, '$'         ; STRING DELIMITER CODE
LOOP:   CP             (HL) ; COMPARE MEMORY CONTENTS WITH DELIMITER
JR      Z, END - 5     ; GO TO END IF CHARACTERS EQUAL
LDI    ; MOVE CHARACTER (HL) to (DE)
        ; INCREMENT HL AND DE, DECREMENT BC
JP     PE, LOOP       ; GO TO "LOOP" IF MORE CHARACTERS
END:    ; OTHERWISE, FALL THROUGH
        ; NOTE P/V FLAG IS USED
        ; TO INDICATE THAT REGISTER BC WAS
        ; DECREMENTED TO ZERO.

```

19 bytes are required for this operation.

- C. Let us assume that a 16-digit decimal number represented in packed BCD format (two BCD digits/byte) has to be shifted as shown in the Figure 10.2 in order to mechanize BCD multiplication or division. The operation can be accomplished as follows:

```

LD      HL, DATA      ; ADDRESS OF FIRST BYTE
LD      B, COUNT       ; SHIFT COUNT
XOR     A              ; CLEAR ACCUMULATOR
ROTAT: RLD            ; ROTATE LEFT LOW ORDER DIGIT IN ACC
        ; WITH DIGITS IN (HL)
INC     HL             ; ADVANCE MEMORY POINTER
DJNZ   ROTAT - 5      ; DECREMENT B AND GO TO ROTAT IF
        ; B IS NOT ZERO, OTHERWISE FALL THROUGH

```

11 bytes are required for this operation.

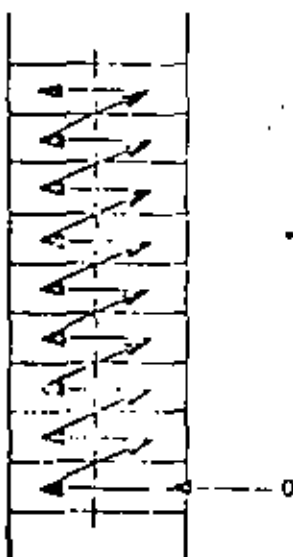

FIGURE 10.2

01/23/76 11:14:37

BUBBLE LISTING

PAGE 1

LOC	OBJ CODE	STMT	SOURCE STATEMENT
		1	; *** STANDARD EXCHANGE (BUBBLE) SORT ROUTINE ***
		2	;
		3	; AT ENTRY: HL CONTAINS ADDRESS OF DATA
		4	C CONTAINS NUMBER OF ELEMENTS TO BE SORTED
		5	(1 < C < 256)
		6	;
		7	; AT EXIT: DATA SORTED IN ASCENDING ORDER
		8	;
		9	; USE OF REGISTERS
		10	;
		11	; REGISTER CONTENTS
		12	;
		13	; A TEMPORARY STORAGE FOR CALCULATIONS
		14	; B COUNTER FOR DATA ARRAY
		15	; C LENGTH OF DATA ARRAY
		16	; D FIRST ELEMENT IN COMPARISON
		17	; E SECOND ELEMENT IN COMPARISON
		18	; H FLAG TO INDICATE EXCHANGE
		19	; L UNUSED
		20	; IX POINTER INTO DATA ARRAY
		21	; IY UNUSED
		22	;
0000	222600	23	SORT: LD (DATA), HL ; SAVE DATA ADDRESS
0003	CB94	24	LOOP: RES FLAG, H ; INITIALIZE EXCHANGE FLAG
0005	41	25	LD B, C ; INITIALIZE LENGTH COUNTER
0006	05	26	DEC B ; ADJUST FOR TESTING
0007	DD2A2600	27	LD IX, (DATA) ; INITIALIZE ARRAY POINTER
0008	DD7E00	28	NEXT: LD A, (IX) ; FIRST ELEMENT IN COMPARISON
000E	57	29	LD D, A ; TEMPORARY STORAGE FOR ELEMENT
000F	DD5E01	30	LD E, (IX+1) ; SECOND ELEMENT IN COMPARISON
0012	93	31	SUB E ; COMPARISON FIRST TO SECOND
0013	3008	32	JR NC, NOEX-S ; IF FIRST > SECOND, NO JUMP
0015	DD7300	33	LD D, (IX), E ; EXCHANGE ARRAY ELEMENTS
0018	DD7201	34	LD D, (IX+1), D
001B	CBC4	35	SET FLAG, H ; RECORD EXCHANGE OCCURRED
001D	DD23	36	NOEX: INC IX ; POINT TO NEXT DATA ELEMENT
001F	10EA	37	DJNZ NEXT-S ; COUNT NUMBER OF COMPARISONS
		38	; REPEAT IF MORE DATA ELEMENTS
0021	CB44	39	BIT FLAG, H ; DETERMINE IF EXCHANGE OCCURRED
0023	20DE	40	JR NZ, LOOP-S ; CONTINUE IF DATA UNSORTED
0025	C9	41	RET ; OTHERWISE, EXIT
		42	;
0026		43	FLAG: FDB 0 ; DESIGNATION OF FLAG BIT
0026		44	DATA: DDB 2 ; STORAGE FOR DATA ADDRESS
		45	END

- B. The following program multiplies two unsigned 16 bit integers and leaves the result in the HL register pair.

01/23/76	11:32:36	MULTIPLY LISTING		PAGE 1
LOC	OBJ CODE	STMT	SOURCE STATEMENT	
0000		1	MULT;	UNSIGNED SIXTEEN BIT INTEGER MULTIPLY.
		2	:	ON ENTRANCE: MULTIPLIER IN DE.
		3	:	MULTPLICAND IN HL
		4	:	
		5	:	ON EXIT: RESULT IN HL.
		6	:	
		7	:	REGISTER USES:
		8	:	
		9	:	
		10	:	H HIGH ORDER PARTIAL RESULT
		11	:	L LOW ORDER PARTIAL RESULT
		12	:	D HIGH ORDER MULTIPLICAND
		13	:	E LOW ORDER MULTIPLICAND
		14	:	B COUNTER FOR NUMBER OF SHIFTS
		15	:	C HIGH ORDER BITS OF MULTIPLIER
		16	:	A LOW ORDER BITS OF MULTIPLIER
		17	:	
0000	0610	18	LD	B, 16; NUMBER OF BITS - INITIALIZE
0002	4A	19	LD	C, D; MOVE MULTIPLIER
0003	7B	20	LD	A, E;
0004	EB	21	EX	DE, HL; MOVE MULTIPLICAND
0005	210000	22	LD	HL, 0; CLEAR PARTIAL RESULT
0006	C839	23	MLOOP: SRL	C; SHIFT MULTIPLIER RIGHT
000A	1F	24	RRA	LEAST SIGNIFICANT BITS
		25	:	IN CARRY.
000B	3001	26	JR	NC, NOADD-S; IF NO CARRY, SKIP THE ADD
000D	19	27	ADD	HL, DE; FUNCTION MULTIPLICAND TO
		28	:	PARTIAL RESULT.
000E	EB	29	NOADD: EX	DE, HL; SHIFT MULTIPLICAND LEFT
000F	39	30	ADD	HL, HL; BY MULTIPLYING IT BY TWO.
0010	EB	31	EX	DE, HL;
0011	10F5	32	DJNZ	MLOOP-S; REPEAT UNTIL NO MORE BITS.
0013	C9	33	RET;	
		34	END;	



Absolute Maximum Ratings

Temperature Under Bias
Storage Temperature
Voltage On Any Pin
with Respect to Ground
Power Dissipation

Specified operating range
-55°C to +150°C
0 V to +7V
1.5W

Comments

Exceeding these limits listed under "Absolute Maximum Rating" may cause permanent damage to the device. This is a stress rating only and functional operation of the device at these or any other set of limits above those indicated in the operational sections of this specification is not implied. Exposure to absolute maximum rating conditions for extended periods may affect device reliability.

66

Note: See Z80A Pin 10 and 11 for details on timing for the military grade part only.

$f_{clk} = 200\text{MHz}$

Z80-CPU D.C. Characteristics

$T_A = 0^\circ\text{C}$ to 70°C , $V_{CC} = 5\text{V} \pm 5\%$ unless otherwise specified.

Symbol	Parameter	Min	Typ	Max	Unit	Test Condition
V_{ILC}	Clock Input Low Voltage	-0.3	0.45		V	
V_{IHC}	Clock Input High Voltage	$V_{CC} - 6$	$V_{CC} + 3$		V	
V_{IL}	Input Low Voltage	-0.3	0.8		V	
V_{IH}	Input High Voltage	2.0	V_{CC}		V	
V_{OL}	Output Low Voltage			0.4	V	$I_{OL} = 15\text{mA}$
V_{OH}	Output High Voltage	2.4			V	$I_{OH} = -20\mu\text{A}$
I_{CC}	Power Supply Current			150	μA	
I_{LI}	Input Leakage Current			10	μA	$V_{IN} = 0$ to V_{CC}
I_{LOH}	Tri-State Output Leakage Current in High State			10	μA	$V_{OUT} = 2.4$ to V_{CC}
I_{LOL}	Tri-State Output Leakage Current in Low State			-10	μA	$V_{OUT} = 0.4\text{V}$
I_{LU}	Bus Leakage Current in Input Mode			-10	μA	$0 \leq V_{IN} \leq V_{CC}$

Capacitance

$T_A = 25^\circ\text{C}$, $f = 1\text{MHz}$

unmeasured pins returned to ground

Symbol	Parameter	Max	Unit
C_0	Clock Capacitance	35	pF
C_{IN}	Input Capacitance	5	pF
C_{OUT}	Output Capacitance	5	pF

Z80-CPU

Ordering Information

C - Ceramic
P - Plastic
S - Standard SN 1000000 to 10000000
E - Extended SN 10000000 to 100000000
M - Military SN 100000000 to 1000000000

Z80A-CPU D.C. Characteristics

$T_A = 0^\circ\text{C}$ to 70°C , $V_{CC} = 5\text{V} \pm 5\%$ unless otherwise specified.

Symbol	Parameter	Min	Typ	Max	Unit	Test Condition
V_{ILC}	Clock Input Low Voltage	-0.3	0.45		V	
V_{IHC}	Clock Input High Voltage	$V_{CC} - 6$	$V_{CC} + 3$		V	
V_{IL}	Input Low Voltage	-0.3	0.8		V	
V_{IH}	Input High Voltage	2.0	V_{CC}		V	
V_{OL}	Output Low Voltage			0.4	V	$I_{OL} = 15\text{mA}$
V_{OH}	Output High Voltage	2.4			V	$I_{OH} = -20\mu\text{A}$
I_{CC}	Power Supply Current		90	200	μA	
I_{LI}	Input Leakage Current			10	μA	$V_{IN} = 0$ to V_{CC}
I_{LOH}	Tri-State Output Leakage Current in High State			10	μA	$V_{OUT} = 2.4$ to V_{CC}
I_{LOL}	Tri-State Output Leakage Current in Low State			-10	μA	$V_{OUT} = 0.4\text{V}$
I_{LU}	Bus Leakage Current in Input Mode			-10	μA	$0 \leq V_{IN} \leq V_{CC}$

Capacitance

$T_A = 25^\circ\text{C}$, $f = 1\text{MHz}$

unmeasured pins returned to ground

Symbol	Parameter	Max	Unit
C_0	Clock Capacitance	35	pF
C_{IN}	Input Capacitance	5	pF
C_{OUT}	Output Capacitance	5	pF

Z80A-CPU

Ordering Information

C - Ceramic
P - Plastic
S - Standard SN 1000000 to 10000000

Item No.	Description	Quantity	Unit	Material Code
1
2
3
4
5
6
7
8
9
10
11
12
13
14
15
16
17
18
19
20
21
22
23
24
25
26
27
28
29
30
31
32
33
34
35
36
37
38
39
40
41
42
43
44
45
46
47
48
49
50

- 101
- 102
- 103
- 104
- 105
- 106
- 107
- 108
- 109
- 110
- 111
- 112
- 113
- 114
- 115
- 116
- 117
- 118
- 119
- 120
- 121
- 122
- 123
- 124
- 125
- 126
- 127
- 128
- 129
- 130
- 131
- 132
- 133
- 134
- 135
- 136
- 137
- 138
- 139
- 140
- 141
- 142
- 143
- 144
- 145
- 146
- 147
- 148
- 149
- 150

Notes:
 1. ...
 2. ...
 3. ...
 4. ...
 5. ...

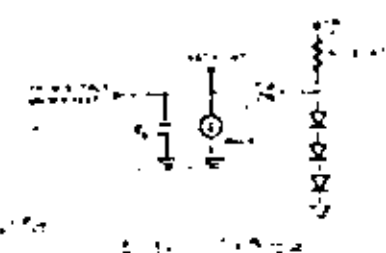

Timing measurements are made at the following voltages, unless otherwise specified:

	71	70
CLOCK	V _{CC} - 6V	45V
DL INPUT	20V	8V
INPUT	20V	8V
FLOAT	3V	10.5V

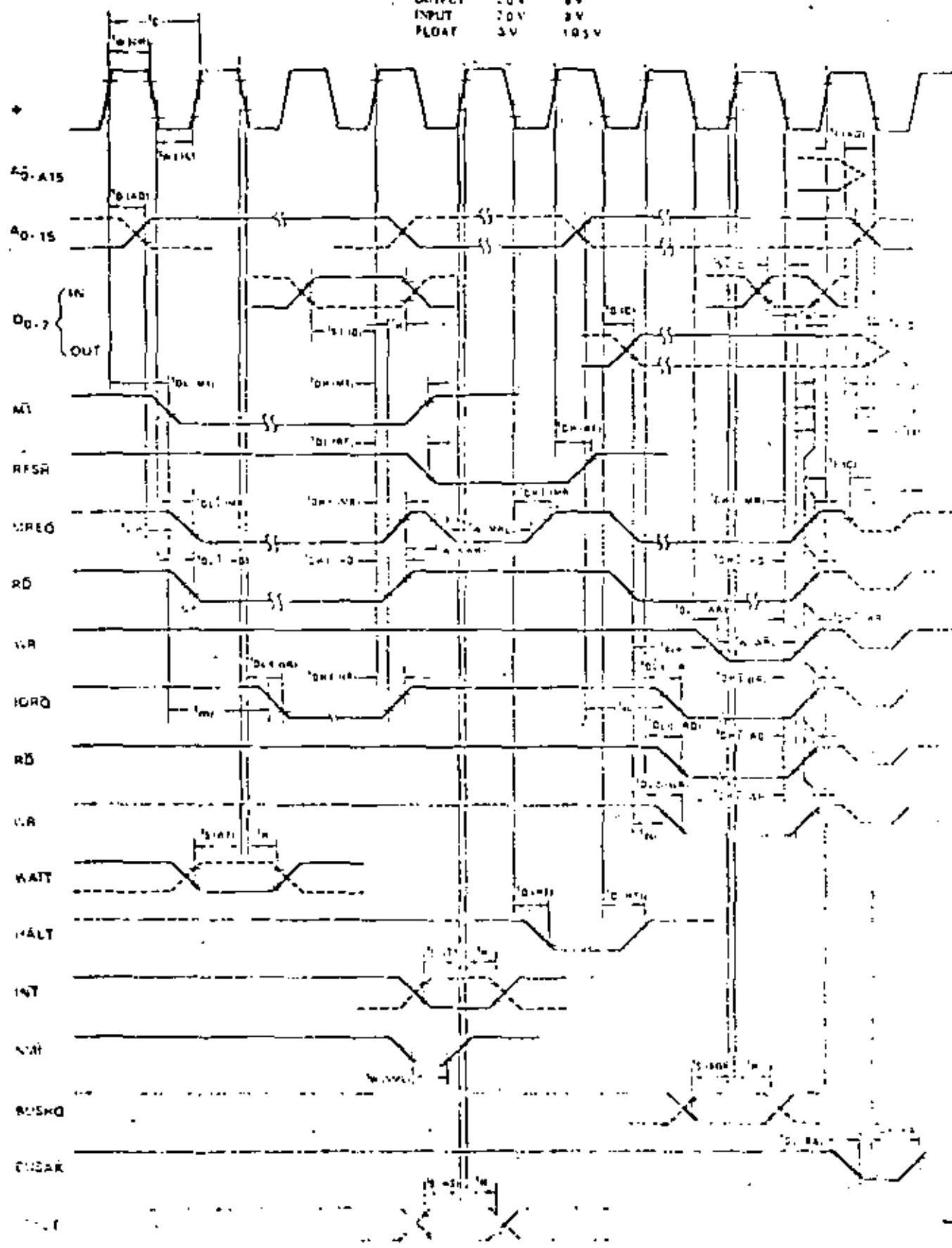

$T_A = 0^\circ\text{C to } 70^\circ\text{C}$, $V_{CC} = 5\text{V} \pm 5\%$ Unless Otherwise Noted.

Symbol	Parameter	Min	Max	Unit	Test Condition
•	Clock Period	25	120	ns	
	Clock Pulse Width (Rising)	110	110	ns	
	Clock Pulse Width (Falling)	110	24	ns	
	Clock Rise/Fall Time		41	ns	
S ₁₀	Address Setup Delay		150	ns	
	Delay to Flash		50	ns	
	Address Setup Delay (M ₁₀ , M ₁₁ , Memory Cache)	117		ns	C _L = 50pF
	Address Setup Delay (M ₁₂ , M ₁₃ , Memory Cache)	117		ns	
D ₁₀	Data Output Delay		150	ns	
	Delay to Flash		50	ns	
	Data Setup Delay (Rising Edge of Clock, M ₁₀ , M ₁₁)	75		ns	C _L = 50pF
	Data Setup Delay (Falling Edge of Clock, M ₁₀ , M ₁₁)	75		ns	
M ₁₀	M ₁₀ Setup Delay (Rising Edge of Clock, M ₁₀ Low)		85	ns	
	M ₁₀ Setup Delay (Rising Edge of Clock, M ₁₀ High)		85	ns	
	M ₁₀ Setup Delay (Falling Edge of Clock, M ₁₀ High)		85	ns	C _L = 50pF
	M ₁₀ Setup Delay (Falling Edge of Clock, M ₁₀ Low)		85	ns	
M ₁₁	M ₁₁ Setup Delay (Rising Edge of Clock, M ₁₁ Low)		75	ns	
	M ₁₁ Setup Delay (Rising Edge of Clock, M ₁₁ High)		75	ns	
	M ₁₁ Setup Delay (Falling Edge of Clock, M ₁₁ High)		75	ns	C _L = 50pF
	M ₁₁ Setup Delay (Falling Edge of Clock, M ₁₁ Low)		75	ns	
M ₁₂	M ₁₂ Setup Delay (Rising Edge of Clock, M ₁₂ Low)		85	ns	
	M ₁₂ Setup Delay (Rising Edge of Clock, M ₁₂ High)		85	ns	
	M ₁₂ Setup Delay (Falling Edge of Clock, M ₁₂ High)		85	ns	C _L = 50pF
	M ₁₂ Setup Delay (Falling Edge of Clock, M ₁₂ Low)		85	ns	
M ₁₃	M ₁₃ Setup Delay (Rising Edge of Clock, M ₁₃ Low)		75	ns	
	M ₁₃ Setup Delay (Rising Edge of Clock, M ₁₃ High)		75	ns	
	M ₁₃ Setup Delay (Falling Edge of Clock, M ₁₃ High)		75	ns	C _L = 50pF
	M ₁₃ Setup Delay (Falling Edge of Clock, M ₁₃ Low)		75	ns	
M ₁₀	M ₁₀ Setup Delay (Rising Edge of Clock, M ₁₀ Low)		75	ns	
	M ₁₀ Setup Delay (Rising Edge of Clock, M ₁₀ High)		100	ns	
M ₁₁	M ₁₁ Setup Delay (Rising Edge of Clock, M ₁₁ Low)		75	ns	
	M ₁₁ Setup Delay (Rising Edge of Clock, M ₁₁ High)		100	ns	
M ₁₂	M ₁₂ Setup Delay (Rising Edge of Clock, M ₁₂ Low)		85	ns	
	M ₁₂ Setup Delay (Rising Edge of Clock, M ₁₂ High)		100	ns	
M ₁₃	M ₁₃ Setup Delay (Rising Edge of Clock, M ₁₃ Low)		75	ns	
	M ₁₃ Setup Delay (Rising Edge of Clock, M ₁₃ High)		100	ns	
WAIT	WAIT Setup Delay (Rising Edge of Clock)	10		ns	
WAIT	WAIT Setup Delay (Falling Edge of Clock)		50	ns	C _L = 50pF
INT	INT Setup Delay (Rising Edge of Clock)	10		ns	
NMI	NMI Setup Delay (Rising Edge of Clock)	10		ns	
M ₁₀	M ₁₀ Setup Delay (Rising Edge of Clock)	10		ns	
M ₁₁	M ₁₁ Setup Delay (Rising Edge of Clock, M ₁₁ Low)		75	ns	
M ₁₁	M ₁₁ Setup Delay (Rising Edge of Clock, M ₁₁ High)		100	ns	C _L = 50pF
M ₁₂	M ₁₂ Setup Delay (Rising Edge of Clock)	10		ns	
M ₁₃	M ₁₃ Setup Delay (Rising Edge of Clock)		80	ns	
M ₁₀	M ₁₀ Setup Delay (Rising Edge of Clock)	110		ns	

- 10) $t_{RST} = 100 \text{ ns}$
- 11) $t_{RST} = 100 \text{ ns}$
- 12) $t_{RST} = 100 \text{ ns}$
- 13) $t_{RST} = 100 \text{ ns}$
- 14) $t_{RST} = 100 \text{ ns}$
- 15) $t_{RST} = 100 \text{ ns}$
- 16) $t_{RST} = 100 \text{ ns}$
- 17) $t_{RST} = 100 \text{ ns}$
- 18) $t_{RST} = 100 \text{ ns}$
- 19) $t_{RST} = 100 \text{ ns}$
- 20) $t_{RST} = 100 \text{ ns}$
- 21) $t_{RST} = 100 \text{ ns}$
- 22) $t_{RST} = 100 \text{ ns}$
- 23) $t_{RST} = 100 \text{ ns}$
- 24) $t_{RST} = 100 \text{ ns}$
- 25) $t_{RST} = 100 \text{ ns}$
- 26) $t_{RST} = 100 \text{ ns}$
- 27) $t_{RST} = 100 \text{ ns}$
- 28) $t_{RST} = 100 \text{ ns}$
- 29) $t_{RST} = 100 \text{ ns}$
- 30) $t_{RST} = 100 \text{ ns}$
- 31) $t_{RST} = 100 \text{ ns}$
- 32) $t_{RST} = 100 \text{ ns}$
- 33) $t_{RST} = 100 \text{ ns}$
- 34) $t_{RST} = 100 \text{ ns}$
- 35) $t_{RST} = 100 \text{ ns}$
- 36) $t_{RST} = 100 \text{ ns}$
- 37) $t_{RST} = 100 \text{ ns}$
- 38) $t_{RST} = 100 \text{ ns}$
- 39) $t_{RST} = 100 \text{ ns}$
- 40) $t_{RST} = 100 \text{ ns}$
- 41) $t_{RST} = 100 \text{ ns}$
- 42) $t_{RST} = 100 \text{ ns}$
- 43) $t_{RST} = 100 \text{ ns}$
- 44) $t_{RST} = 100 \text{ ns}$
- 45) $t_{RST} = 100 \text{ ns}$
- 46) $t_{RST} = 100 \text{ ns}$
- 47) $t_{RST} = 100 \text{ ns}$
- 48) $t_{RST} = 100 \text{ ns}$
- 49) $t_{RST} = 100 \text{ ns}$
- 50) $t_{RST} = 100 \text{ ns}$
- 51) $t_{RST} = 100 \text{ ns}$
- 52) $t_{RST} = 100 \text{ ns}$
- 53) $t_{RST} = 100 \text{ ns}$
- 54) $t_{RST} = 100 \text{ ns}$
- 55) $t_{RST} = 100 \text{ ns}$
- 56) $t_{RST} = 100 \text{ ns}$
- 57) $t_{RST} = 100 \text{ ns}$
- 58) $t_{RST} = 100 \text{ ns}$
- 59) $t_{RST} = 100 \text{ ns}$
- 60) $t_{RST} = 100 \text{ ns}$
- 61) $t_{RST} = 100 \text{ ns}$
- 62) $t_{RST} = 100 \text{ ns}$
- 63) $t_{RST} = 100 \text{ ns}$
- 64) $t_{RST} = 100 \text{ ns}$
- 65) $t_{RST} = 100 \text{ ns}$
- 66) $t_{RST} = 100 \text{ ns}$
- 67) $t_{RST} = 100 \text{ ns}$
- 68) $t_{RST} = 100 \text{ ns}$
- 69) $t_{RST} = 100 \text{ ns}$
- 70) $t_{RST} = 100 \text{ ns}$
- 71) $t_{RST} = 100 \text{ ns}$
- 72) $t_{RST} = 100 \text{ ns}$
- 73) $t_{RST} = 100 \text{ ns}$
- 74) $t_{RST} = 100 \text{ ns}$
- 75) $t_{RST} = 100 \text{ ns}$
- 76) $t_{RST} = 100 \text{ ns}$
- 77) $t_{RST} = 100 \text{ ns}$
- 78) $t_{RST} = 100 \text{ ns}$
- 79) $t_{RST} = 100 \text{ ns}$
- 80) $t_{RST} = 100 \text{ ns}$
- 81) $t_{RST} = 100 \text{ ns}$
- 82) $t_{RST} = 100 \text{ ns}$
- 83) $t_{RST} = 100 \text{ ns}$
- 84) $t_{RST} = 100 \text{ ns}$
- 85) $t_{RST} = 100 \text{ ns}$
- 86) $t_{RST} = 100 \text{ ns}$
- 87) $t_{RST} = 100 \text{ ns}$
- 88) $t_{RST} = 100 \text{ ns}$
- 89) $t_{RST} = 100 \text{ ns}$
- 90) $t_{RST} = 100 \text{ ns}$
- 91) $t_{RST} = 100 \text{ ns}$
- 92) $t_{RST} = 100 \text{ ns}$
- 93) $t_{RST} = 100 \text{ ns}$
- 94) $t_{RST} = 100 \text{ ns}$
- 95) $t_{RST} = 100 \text{ ns}$
- 96) $t_{RST} = 100 \text{ ns}$
- 97) $t_{RST} = 100 \text{ ns}$
- 98) $t_{RST} = 100 \text{ ns}$
- 99) $t_{RST} = 100 \text{ ns}$
- 100) $t_{RST} = 100 \text{ ns}$

1. All voltages are with respect to ground.
 2. All currents are with respect to ground.
 3. All timing is with respect to the rising edge of the clock signal.
 4. All timing is with respect to the falling edge of the clock signal.
 5. All timing is with respect to the rising edge of the clock signal.
 6. All timing is with respect to the falling edge of the clock signal.
 7. All timing is with respect to the rising edge of the clock signal.
 8. All timing is with respect to the falling edge of the clock signal.
 9. All timing is with respect to the rising edge of the clock signal.
 10. All timing is with respect to the falling edge of the clock signal.



Z80-CPU
Zilog INSTRUCTION SET

ADC HL, ss	Add with Carry Reg. pair ss to HL	DEC IY	Decrement IY
ADC A, s	Add with carry operand s to Acc.	DEC ss	Decrement Reg. pair ss
ADD A, n	Add value n to Acc.	DI	Disable interrupts
ADD A, r	Add Reg. r to Acc.	DJNZ e	Decrement B and Jump relative if B≠0
ADD A, (HL)	Add location (HL) to Acc.	EI	Enable interrupts
ADD A, (IX+d)	Add location (IX+d) to Acc.	EX (SP), HL	Exchange the location (SP) and HL
ADD A, (IY+d)	Add location (IY+d) to Acc.	EX (SP), IX	Exchange the location (SP) and IX
ADD HL, ss	Add Reg. pair ss to HL	EX (SP), IY	Exchange the location (SP) and IY
ADD IX, pp	Add Reg. pair pp to IX	EX AF, AF'	Exchange the contents of AF and AF'
ADD IY, rr	Add Reg. pair rr to IY	EX DE, HL	Exchange the contents of DE and HL
AND s	Logical "AND" of operand s and Acc.	EXX	Exchange the contents of BC, DE, HL with contents of BC', DE', HL' respectively
BIT b, (HL)	Test BIT b of location (HL)	HALT	HALT (wait for interrupt or reset)
BIT b, (IX+d)	Test BIT b of location (IX+d)	IM 0	Set interrupt mode 0
BIT b, (IY+d)	Test BIT b of location (IY+d)	IM 1	Set interrupt mode 1
BIT b, r	Test BIT b of Reg. r	IM 2	Set interrupt mode 2
CALL cc, nn	Call subroutine at location nn if condition cc is true	IN A, (n)	Load the Acc. with input from device n
CALL nn	Unconditional call subroutine at location nn	IN r, (C)	Load the Reg. r with input from device (C)
CCF	Complement carry flag	INC (HL)	Increment location (HL)
CP s	Compare operand s with Acc.	INC IX	Increment IX
CPD	Compare location (HL) with Acc., decrement HL and BC	INC (IX+d)	Increment location (IX+d)
CPDR	Compare location (HL) and Acc., decrement HL and BC, repeat until BC=0	INC IY	Increment IY
CPI	Compare location (HL) with Acc., increment HL and decrement BC	INC (IY+d)	Increment location (IY+d)
CPIR	Compare location (HL) and Acc., increment HL, decrement BC, repeat until BC=0	INC r	Increment Reg. r
DAA	Decimal adjust Acc.	IN C, ss	Load input from port ss
DAD D	Decrement Acc. by D	IND	Load location (HL) with input from port (D), decrement HL and B
DAD D'	Decrement Acc. by D'	INDR	Load location (HL) with input from port (D), decrement HL and B, repeat until B=0
DAD HL	Decrement Acc. by HL	INI	Load location (HL) with input from port (C), decrement HL and B

LDIR	Load location (HL) with input from port (C), increment HL and decrement B, repeat until B=0	LD (nn), A	Load location (nn) with Acc.
LD (nn), dd	Load location (nn) with Reg. pair dd	LD (nn), HL	Load location (nn) with HL
LD (nn), IX	Load location (nn) with IX	LD (nn), IY	Load location (nn) with IY
LD (nn), IY	Load location (nn) with IY	LD R, A	Load R with Acc.
LD cc, nn	Jump to location nn if condition cc is true	LD r, (HL)	Load Reg. r with location (HL)
LD nn	Unconditional jump to location nn	LD r, (IX+d)	Load Reg. r with location (IX+d)
LD PC, e	Jump relative to PC+e if carry=1	LD r, (IY+d)	Load Reg. r with location (IY+d)
LD r, e	Unconditional Jump relative to PC+e	LD r, n	Load Reg. r with value n
LD r, e	Jump relative to PC+e if carry=0	LD r, r'	Load Reg. r with Reg. r'
LD r, e	Jump relative to PC+e if non zero (Z=0)	LD SP, HL	Load SP with HL
LD r, e	Jump relative to PC+e if zero (Z=1)	LD SP, IX	Load SP with IX
LD A, (BC)	Load Acc. with location (BC)	LD SP, IY	Load SP with IY
LD A, (DE)	Load Acc. with location (DE)	LDD	Load location (DE) with location (HL), decrement DE, HL and BC
LD A, I	Load Acc. with I	LDDR	Load location (DE) with location (HL), decrement DE, HL and BC; repeat until BC=0
LD A, (nn)	Load Acc. with location nn	LDI	Load location (DE) with location (HL), increment DE, HL, decrement BC
LD A, R	Load Acc. with Reg. R	LDIR	Load location (DE) with location (HL), increment DE, HL, decrement BC and repeat until BC=0
LD (BC), A	Load location (BC) with Acc.	NEG	Negate Acc. (2's complement)
LD (DE), A	Load location (DE) with Acc.	NOP	No operation
LD (HL), n	Load location (HL) with value n	OR s	Logical 'OR' of operand s and Acc.
LD dd, nn	Load Reg. pair dd with value nn	OTDR	Load output port (C) with location (HL), decrement HL and B, repeat until B=0
LD HL, (nn)	Load HL with location (nn)	OTIR	Load output port (C) with location (HL), increment HL, decrement B, repeat until B=0
LD (HL), r	Load location (HL) with Reg. r	OUT (C), r	Load output port (C) with Reg. r
LD I, A	Load I with Acc.	OUT (d), A	Load output port (d) with Acc.
LD IX, nn	Load IX with value nn	OUTD	Load output port (C) with location (HL), decrement HL and B
LD IX, (nn)	Load IX with location (nn)	OUTI	Load output port (C) with location (HL), increment HL, decrement B
LD (IX+d), n	Load location (IX+d) with value n		
LD (R1), r	Load location (R1) with Reg. r		
LD IY, nn	Load IY with value nn		
LD IY, (nn)	Load IY with location (nn)		
LDI d, n	Load location (d) with value n		
LDI (d), r	Load location (d) with Reg. r		

POP IX	Load IX with top of stack	RR m	Rotate right through carry operand m
POP IY	Load IY with top of stack	RRA	Rotate right Acc. through carry
POP qq	Load Reg. pair qq with top of stack	RRC m	Rotate operand m right circular
PUSH IX	Load IX onto stack	RRCA	Rotate right circular Acc.
PUSH IY	Load IY onto stack	RRD	Rotate digit right and left between Acc. and location (HL)
PUSH qq	Load Reg. pair qq onto stack	RST p	Restart to location p
RES b, m	Reset Bit b of operand m	SBC A, s	Subtract operand s from Acc. with carry
RET	Return from subroutine	SBC HL, ss	Subtract Reg. pair ss from HL with carry
RET cc	Return from subroutine if condition cc is true	SCF	Set carry flag (C=1)
RETI	Return from interrupt	SET b, (HL)	Set Bit b of location (HL)
RETN	Return from non maskable interrupt	SET b, (IX+d)	Set Bit b of location (IX+d)
RL m	Rotate left through carry operand m	SET b, (IY+d)	Set Bit b of location (IY+d)
RLA	Rotate left Acc. through carry	SET b, r	Set Bit b of Reg. r
RLC (HL)	Rotate location (HL) left circular	SLA m	Shift operand m left arithmetic
RLC (IX+d)	Rotate location (IX+d) left circular	SRA m	Shift operand m right arithmetic
RLC (IY+d)	Rotate location (IY+d) left circular	SRL m	Shift operand m right logical
RLC r	Rotate Reg. r left circular	SUB s	Subtract operand s from Acc.
RLCA	Rotate left circular Acc.	XOR s	Exclusive 'OR' operand s and Acc.
RLD	Rotate digit left and right between Acc. and location (HL)		

Z80™-PIO
Z80A™-PIO
 Technical Manual

1.0	Introduction	1
2.0	Architecture	3
3.0	Pin Description	5
4.0	Programming the PIO	9
4.1	Reset	9
4.2	Loading the Interrupt Vector	9
4.3	Selecting an Operating Mode	10
4.4	Setting the Interrupt Control Word	11
5.0	Timing	13
5.1	Output Mode (Mode 0)	13
5.2	Input Mode (Mode 1)	13
5.3	Bidirectional Mode (Mode 2)	14
5.4	Control Mode (Mode 3)	14
6.0	Interrupt Control	15
7.0	Applications	17
7.1	Interrupt Daisy Chain	17
7.2	I/O Device Interface	18
7.3	Control Interface	19
8.0	Programming Summary	21
8.1	Load Interrupt Vector	21
8.2	Set Mode	21
8.3	Set Interrupt Control	21
9.0	Electrical Specifications	23
9.1	Absolute Maximum Ratings	23
9.2	D C. Characteristics	23
9.3	Clock Driver	23
9.4	A C. Characteristics	24
9.5	Capacitance	24
10.0	Timing Chart	25

1.0 INTRODUCTION

The Z80 Parallel I/O (PIO) Circuit is a programmable, two port device which provides a TTL compatible interface between peripheral devices and the Z80 CPU. The CPU can configure the Z80 PIO to interface with a wide range of peripheral devices with no other external logic required. Typical peripheral devices that are fully compatible with the Z80 PIO include most keyboards, paper tape readers and punches, printers, PROM programmers, etc. The Z80 PIO utilizes N channel silicon gate depletion load technology and is packaged in a 40 pin DIP. Major features of the Z80-PIO include:

- Two independent 8 bit bidirectional peripheral interface ports with 'handshake' data transfer control
- Interrupt driven 'handshake' for fast response
- Any one of four distinct modes of operation may be selected for a port including:
 - Byte output
 - Byte input
 - Byte bidirectional bus (Available on Port A only)
 - Bit control mode
- All with interrupt controlled handshake
- Daisy chain priority interrupt logic included to provide for automatic interrupt vectoring without external logic
- Eight outputs are capable of driving Darlington transistors
- All inputs and outputs fully TTL compatible
- Single 5 volt supply and single phase clock are required

One of the unique features of the Z80-PIO that separates it from other interface controllers is that all data transfer between the peripheral device and the CPU is accomplished under total interrupt control. The interrupt logic of the PIO permits full usage of the efficient interrupt capabilities of the Z80-CPU during I/O transfers. All logic necessary to implement a fully nested interrupt structure is included in the PIO so that additional circuits are not required. Another unique feature of the PIO is that it can be programmed to interrupt the CPU on the occurrence of specified status conditions in the peripheral device. For example, the PIO can be programmed to interrupt if any specified peripheral alarm conditions should occur. This interrupt capability reduces the amount of time that the processor must spend in polling peripheral status.

2.0 PIO ARCHITECTURE

A block diagram of the Z80-PIO is shown in Figure 2.0-1. The internal structure of the Z80 PIO consists of a Z80 CPU bus interface, internal control logic, Port A I/O logic, Port B I/O logic, and interrupt control logic. The CPU bus interface logic allows the PIO to interface directly to the Z80-CPU with no other external logic. However, address decoders and/or line buffers may be required for large systems. The internal control logic synchronizes the CPU data bus to the peripheral device interfaces (Port A and Port B). The two I/O ports (A and B) are virtually identical and are used to interface directly to peripheral devices.

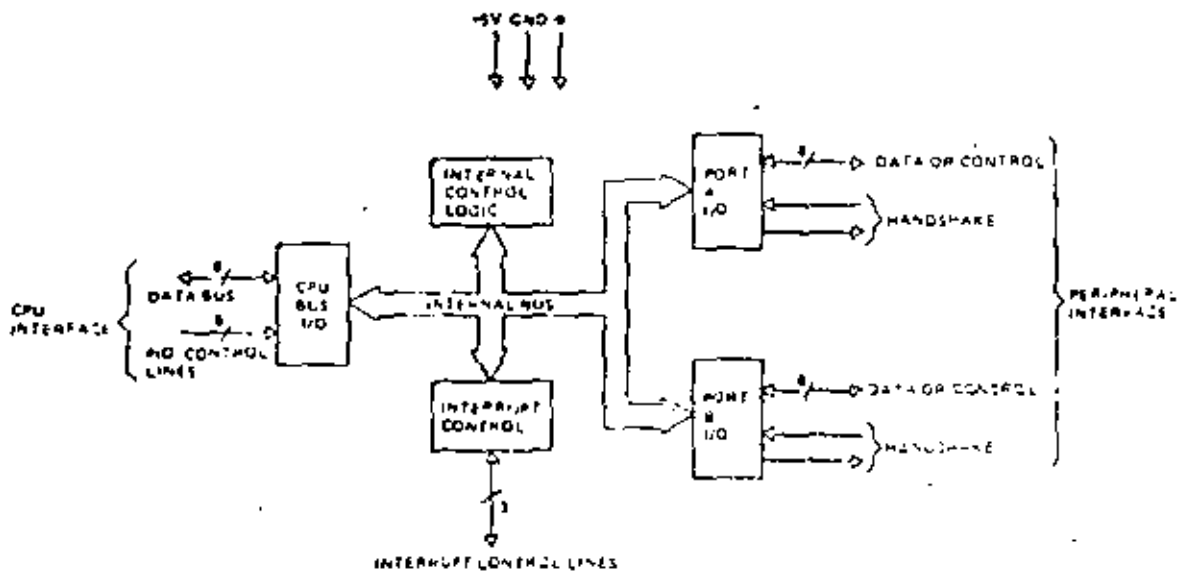

FIGURE 2.0-1
PIO BLOCK DIAGRAM

The Port I/O logic is composed of 6 registers with "handshake" control logic as shown in Figure 2.0-2. The registers include: an 8 bit data input register, an 8 bit data output register, a 2 bit mode control register, an 8 bit mask register, an 8 bit input/output select register, and a 2 bit mask control register.

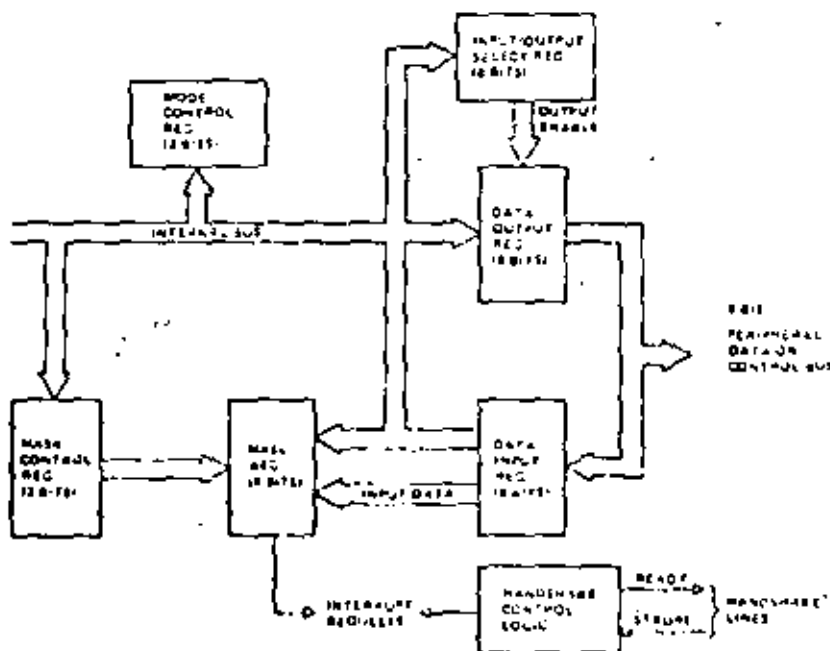

FIGURE 2.0-2
PORT I/O BLOCK DIAGRAM

The 2-bit mode control register is loaded by the CPU to select the desired operating mode (byte output, byte input, byte bidirectional bus, or bit control mode). All data transfer between the peripheral device and the CPU is achieved through the data input and data output registers. Data may be written into the output register by the CPU or read back to the CPU from the input register at any time. The handshake lines associated with each port are used to control the data transfer between the PIO and the peripheral device.

The 8-bit mask register and the 8-bit input/output select register are used only in the bit control mode. In this mode any of the 8 peripheral data or control bus pins can be programmed to be an input or an output as specified by the select register. The mask register is used in this mode in conjunction with a special interrupt feature. This feature allows an interrupt to be generated when any or all of the unmasked pins reach a specified state (either high or low). The 2-bit mask control register specifies the active state desired (high or low) and if the interrupt should be generated when *all* unmasked pins are active (AND condition) or when *any* unmasked pin is active (OR condition). This feature reduces the requirement for CPU status checking of the peripheral by allowing an interrupt to be automatically generated on specific peripheral status conditions. For example, in a system with 3 alarm conditions, an interrupt may be generated if any one occurs or if all three occur.

The interrupt control logic section handles all CPU interrupt produced for nested priority interrupt structures. The priority of any device is determined by its physical location in a daisy chain configuration. Two lines are provided on each PIO to form the daisy chain. The device closest to the CPU has the highest priority. Within a PIO, Part A interrupts have higher priority than those of Part B. In the byte input, byte output or bidirectional modes, an interrupt can be generated whenever a new byte transfer is requested by the peripheral. In the bit control mode an interrupt can be generated when the peripheral status register is a programmed value. The PIO provides for complete control of nested interrupts. That is, lower priority devices may not interrupt higher priority devices that have not had their interrupt service routine completed by the CPU. Higher priority devices may interrupt the servicing of lower priority devices.

When an interrupt is accepted by the CPU in mode 2, the interrupting device must provide an 8-bit interrupt vector for the CPU. This vector is used to form a pointer to a location in the computer memory where the address of the interrupt service routine is located. The 8-bit vector from the interrupting device forms the least significant 8 bits of the indirect pointer while the I Register in the CPU provides the most significant 8 bits of the pointer. Each port (A and B) has an independent interrupt vector. The least significant bit of the vector is automatically set to a 0 within the PIO since the pointer must point to two adjacent memory locations for a complete 16-bit address.

The PIO decodes the RETI (Return from interrupt) instruction directly from the CPU data bus so that each PIO in the system knows at all times whether it is being serviced by the CPU interrupt service routine without any other communication with the CPU.

3.0 PIN DESCRIPTION

A diagram of the Z80 PIO pin configuration is shown in Figure 3-0-1. This section describes the function of each pin.

D_7-D_0	Z80-CPU Data Bus (bidirectional, tristate) This bus is used to transfer all data and commands between the Z80 CPU and the Z80 PIO. D_0 is the least significant bit of the bus.
B/A Sel	Port B or A Select (input, active high) This pin defines which port will be accessed during a data transfer between the Z80-CPU and the Z80-PIO. A low level on this pin selects Port A while a high level selects Port B. Often Address bit A_0 from the CPU will be used for this selection function.
C/D Sel	Control or Data Select (input, active high) This pin defines the type of data transfer to be performed between the CPU and the PIO. A high level on this pin during a CPU write to the PIO causes the Z80 data bus to be interpreted as a <i>command</i> for the port selected by the B/A Select line. A low level on this pin means that the Z80 data bus is being used to transfer data between the CPU and the PIO. Often Address bit A_1 from the CPU will be used for this function.
\overline{CE}	Chip Enable (input, active low) A low level on this pin enables the PIO to accept commands or data inputs from the CPU during a write cycle or to transmit data to the CPU during a read cycle. This signal is generally a decode of four I/O port numbers that encompass port A and B. Data and Control.
Φ	System Clock (input) The Z80-PIO uses the standard Z80 system clock to synchronize certain signals internally. This is a single phase clock.
\overline{MI}	Machine Cycle One Signal from CPU (input, active low) This signal from the CPU is used as a sync pulse to control several internal PIO operations. When \overline{MI} is active and the \overline{RD} signal is active, the Z80 CPU is fetching an instruction from memory. Conversely, when \overline{MI} is active and \overline{IORQ} is active, the CPU is acknowledging an interrupt. In addition, the \overline{MI} signal has two other functions within the Z80 PIO: <ol style="list-style-type: none"> 1. \overline{MI} synchronizes the PIO interrupt logic. 2. When \overline{MI} occurs without an active \overline{RD} or \overline{IORQ} signal the PIO logic enters a reset state.
\overline{IORQ}	Input/Output Request from Z80-CPU (input, active low) The \overline{IORQ} signal is used in conjunction with the B/A Select, C/D Select, \overline{CE} , and \overline{RD} signals to transfer commands and data between the Z80 CPU and the Z80 PIO. When \overline{CE} , \overline{RD} and \overline{IORQ} are active, the port addressed by B/A will transfer data to the CPU (a read operation). Conversely, when \overline{CE} and \overline{IORQ} are active but \overline{RD} is not active, then the port addressed by B/A will be written into from the CPU, with either data or control information as specified by the C/D Select signal. Also, if \overline{IORQ} and \overline{MI} are active simultaneously, the CPU is acknowledging an interrupt and the interrupting port will automatically place its interrupt vector on the CPU data bus if it is the highest priority device requesting an interrupt.
\overline{RD}	Read Cycle Status from the Z80 CPU (input, active low) If \overline{RD} is active a MEMORY READ or I/O READ operation is in progress. The \overline{RD} signal is used with B/A Select, C/D Select, \overline{CE} , and \overline{IORQ} signals to transfer data from the Z80-PIO to the Z80-CPU.

- IEI** **Interrupt Enable In (input, active high)**
This signal is used to form a priority interrupt daisy chain when more than one interrupt driven device is being used. A high level on this pin indicates that no other devices of higher priority are being serviced by a CPU interrupt service routine.
- IEO** **Interrupt Enable Out (output, active high)**
The IEO signal is the other signal required to form a daisy chain priority scheme. It is high only if IEI is high and the CPU is not servicing an interrupt from this PIO. Thus this signal blocks lower priority devices from interrupting while a higher priority device is being serviced by its CPU interrupt service routine.
- $\overline{\text{INT}}$** **Interrupt Request (output, open drain, active low)**
When $\overline{\text{INT}}$ is active the Z80-PIO is requesting an interrupt from the Z80-CPU.
- $A_0 - A_7$** **Port A Bus (bidirectional, tristate)**
This 8 bit bus is used to transfer data and/or status or control information between Port A of the Z80-PIO and a peripheral device. A_0 is the least significant bit of the Port A data bus.
- $A \overline{\text{STB}}$** **Port A Strobe Pulse from Peripheral Device (input, active low)**
The meaning of this signal depends on the mode of operation selected for Port A as follows:
- 1) **Output mode:** The positive edge of this strobe is issued by the peripheral to acknowledge the receipt of data made available by the PIO.
 - 2) **Input mode:** The strobe is issued by the peripheral to load data from the peripheral into the Port A input register. Data is loaded into the PIO when this signal is active.
 - 3) **Bidirectional mode:** When this signal is active, data from the Port A output register is gated onto Port A bidirectional data bus. The positive edge of the strobe acknowledges the receipt of the data.
 - 4) **Control mode:** The strobe is inhibited internally.
- A RDY** **Register A Ready (output, active high)**
The meaning of this signal depends on the mode of operation selected for Port A as follows:
- 1) **Output mode:** This signal goes active to indicate that the Port A output register has been loaded and the peripheral data bus is stable and ready for transfer to the peripheral device.
 - 2) **Input mode:** This signal is active when the Port A input register is empty and is ready to accept data from the peripheral device.
 - 3) **Bidirectional mode:** This signal is active when data is available in the Port A output register for transfer to the peripheral device. In this mode data is not placed on the Port A data bus unless $A \overline{\text{STB}}$ is active.
 - 4) **Control mode:** This signal is disabled and forced to a low state.
- $B_0 - B_7$** **Port B Bus (bidirectional, tristate)**
This 8 bit bus is used to transfer data and/or status or control information between Port B of the PIO and a peripheral device. The Port B data bus is capable of supplying a maximum 1.5V to drive Darlington transistors. B_0 is the least significant bit of the bus.
- $B \overline{\text{STB}}$** **Port B Strobe Pulse from Peripheral Device (input, active low)**
The meaning of this signal is similar to that of $A \overline{\text{STB}}$ with the following exception:
In the Port A bidirectional mode this signal strobes data from the peripheral device into the Port A input register.
- B RDY** **Register B Ready (output, active high)**
The meaning of this signal is similar to that of A Ready with the following exception:
In the Port A bidirectional mode this signal is high when the Port A input register is empty and ready to accept data from the peripheral device.



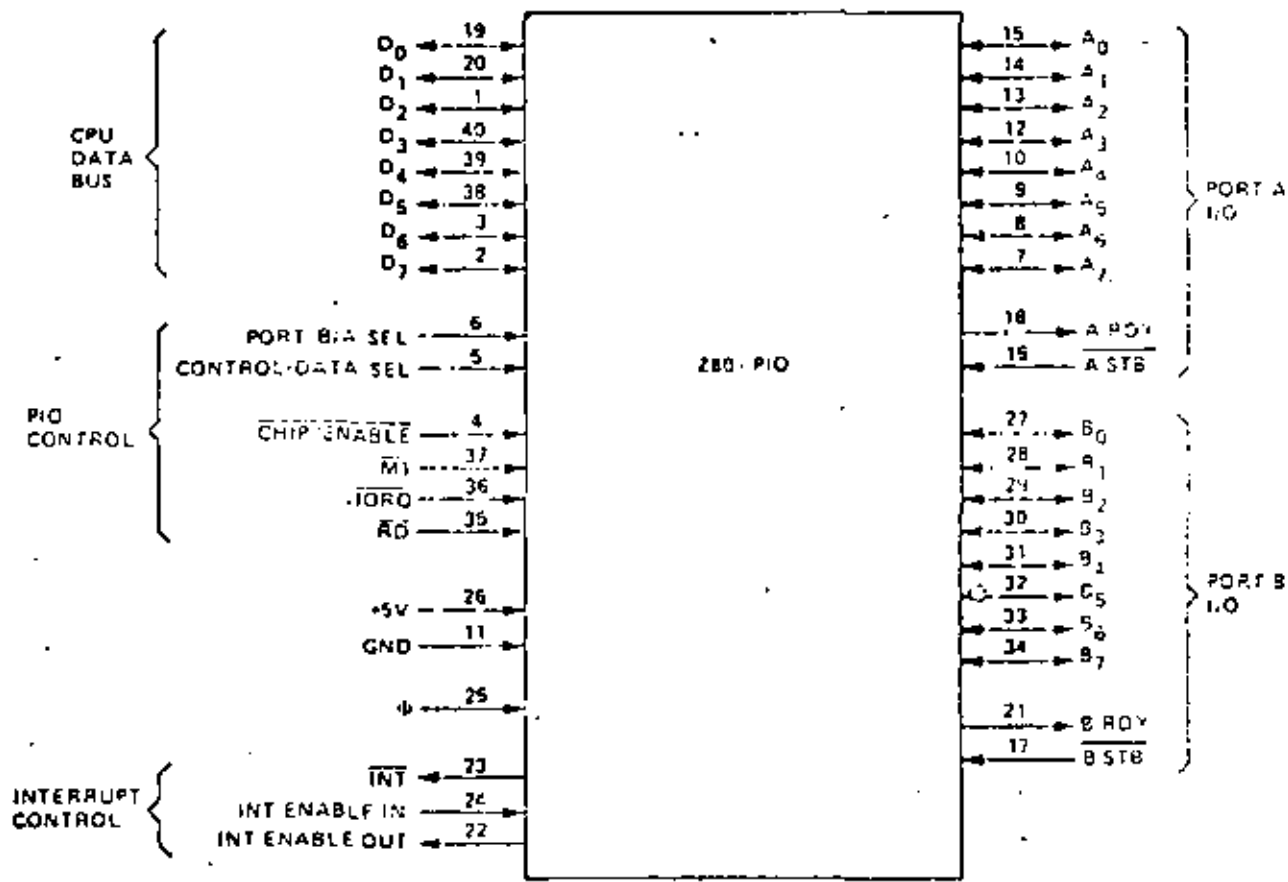

FIGURE 3 0 1
PIO PIN CONFIGURATION

4.0 PROGRAMMING THE PIO

4.1 RESET

The Z80 PIO automatically enters a reset state when power is applied. The reset state performs the following functions:

- 1) Both port mask registers are reset to inhibit all port data bits.
- 2) Port Data bus lines are set to a high impedance state and the Ready "handshake" signals are inactive (low). Mode 1 is automatically selected.
- 3) The vector address registers are *not* reset.
- 4) Both port interrupt enable flip flops are reset.
- 5) Both port output registers are reset.

In addition to the automatic power on reset, the PIO can be reset by applying an \overline{MR} signal without the presence of a \overline{RD} or \overline{IORQ} signal. If no \overline{RD} or \overline{IORQ} is detected during \overline{MR} the PIO will enter the reset state immediately after the \overline{MR} signal goes inactive. The purpose of this reset is to allow a single external gate to generate a reset without a power down sequence. This approach was required due to the 40 pin packaging limitation.

Once the PIO has entered the internal reset state it is held there until the PIO receives a control word from the CPU.

4.2 LOADING THE INTERRUPT VECTOR

The PIO has been designed to operate with the Z80-CPU using the mode 2 interrupt response. This mode requires that an interrupt vector be supplied by the interrupting device. This vector is used by the CPU to form the address for the interrupt service routine of that port. This vector is placed on the Z80 data bus during an interrupt acknowledge cycle by the highest priority device requesting service at that time. (Refer to the Z80 CPU Technical Manual for details on how an interrupt is serviced by the CPU.) The desired interrupt vector is loaded into the PIO by writing a control word to the desired port of the PIO with the following format:

D7	D6	D5	D4	D3	D2	D1	D0
V7	V6	V5	V4	V3	V2	V1	0

signifies this control word is an interrupt vector.

D0 is used in this case as a flag bit which when low causes V7 thru V1 to be loaded into the vector registers. At interrupt acknowledge time, the vector of the interrupting port will appear on the Z80 data bus exactly as shown in the format above.

4.3 SELECTING AN OPERATING MODE

Port A of the PIO may be operated in any of four distinct modes: Mode 0 (output mode), Mode 1 (input mode), Mode 2 (bidirectional mode), and Mode 3 (control mode). Note that the mode numbers have been selected for mnemonic significance; i.e. 0=Out, 1=In, 2=Bidirectional. Port B can operate in any of these modes except Mode 2.

The mode of operation must be established by writing a control word to the PIO in the following format:

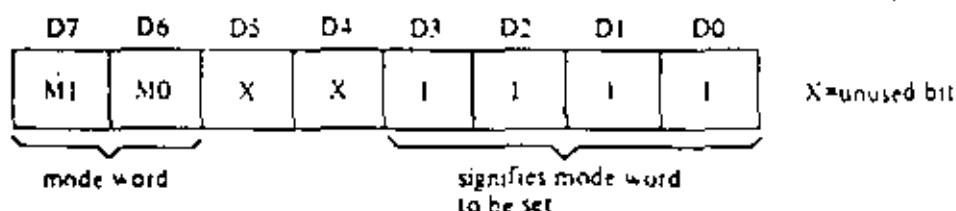

Bits D7 and D6 from the binary code for the desired mode according to the following table:

D7	D6	Mode
0	0	0 (output)
0	1	1 (input)
1	0	2 (bidirectional)
1	1	3 (control)

Bits D5 and D4 are ignored. Bits D3-D0 must be set to 1111 to indicate "Set Mode".

Selecting Mode 0 enables any data written to the port output register by the CPU to be enabled onto the port data bus. The contents of the output register may be changed at any time by the CPU simply by writing a new data word to the port. Also the current contents of the output register may be read back to the Z80-CPU at any time through the execution of an input instruction.

With Mode 0 active, a data write from the CPU causes the Ready handshake line of that port to go high to notify the peripheral that data is available. This signal remains high until a strobe is received from the peripheral. The rising edge of the strobe generates an interrupt (if it has been enabled) and causes the Ready line to go inactive. This very simple handshake is similar to that used in many peripheral devices.

Selecting Mode 1 puts the port into the input mode. To start handshake operation, the CPU merely performs an input read operation from the port. This activates the Ready line to the peripheral to signify that data should be loaded into the empty input register. The peripheral device then strobes data into the port input register using the strobe line. Again, the rising edge of the strobe causes an interrupt request (if it has been enabled) and deactivates the Ready signal. Data may be strobed into the input register regardless of the state of the Ready signal if care is taken to prevent a data overrun condition.

Mode 2 is a bidirectional data transfer mode which uses all four handshake lines. Therefore only Port A may be used for Mode 2 operation. Mode 2 operation uses the Port A handshake signals for output control and the Port B handshake signals for input control. Thus, both A RDY and B RDY may be active simultaneously. The only operational difference between Mode 0 and the output portion of Mode 2 is that data from the Port A output register is allowed on to the port data bus only when $\overline{A\ S\ T\ B}$ is active in order to achieve a bidirectional capability.

Mode 3 operation is intended for status and control applications and does not utilize the handshake signals. When Mode 3 is selected, the next control word sent to the PIO must define which of the port data bus lines are to be inputs and which are outputs. The format of the control word is shown below:

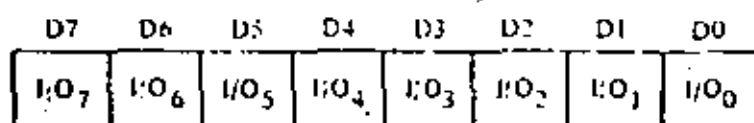

If any bit is set to a one, then the corresponding data bus line will be used as an input. Conversely, if the bit is reset, the line will be used as an output.

During Mode 3 operation the strobe signal is ignored and the Ready line is held low. Data may be written to a port or read from a port by the Z80 CPU at any time during Mode 3 operation. When reading a port, the data returned to the CPU will be composed of input data from port data bus lines assigned as inputs plus port output register data from those lines assigned as outputs.

4.4 SETTING THE INTERRUPT CONTROL WORD

The interrupt control word for each port has the following format.

D7	D6	D5	D4	D3	D2	D1	D0
Enable Interrupt	AND/ OR	High/ Low	Mask follows	0	1	1	1
used in Mode 3 only				signifies interrupt control word			

If bit D7=1 the interrupt enable flip flop of the port is set and the port may generate an interrupt. If bit D7=0 the enable flag is reset and interrupts may not be generated. If an interrupt is pending when the enable flag is set, it will then be enabled onto the CPU interrupt request line. Bits D6, D5, and D4 are used only with Mode 3 operation. However, setting bit D4 of the interrupt control word during any mode of operation will cause any pending interrupt to be reset. These three bits are used to allow for interrupt operation in Mode 3 when any group of the I/O lines go to certain defined states. Bit D6 (AND OR) defines the logical operation to be performed in port monitoring. If bit D6=1, an AND function is specified and if D6=0, an OR function is specified. For example, if the AND function is specified, all bits must go to a specified state before an interrupt will be generated while the OR function will generate an interrupt if any specified bit goes to the active state.

Bit D5 defines the active polarity of the port data bus line to be monitored. If bit D5=1 the port data lines are monitored for a high state while if D5=0 they will be monitored for a low state.

If bit D4=1 the next control word sent to the PIO must define a mask as follows:

D7	D6	D5	D4	D3	D2	D1	D0
MB ₇	MB ₆	MB ₅	MB ₄	MB ₃	MB ₂	MB ₁	MB ₀

Only those port lines whose mask bit is zero will be monitored for generating an interrupt.

5.0 TIMING

5.1 OUTPUT MODE (MODE 0)

Figure 5.0-1 illustrates the timing associated with Mode 0 operation. An output cycle is always started by the execution of an output instruction by the CPU. A \overline{WR}^* pulse is generated by the PIO during a CPU I/O write operation and is used to latch the data from the CPU data bus into the addressed port's A or B output register. The rising edge of the \overline{WR}^* pulse then raises the Ready flag after the next falling edge of Φ to indicate that data is available for the peripheral device. In many systems the rising edge of the Ready signal can be used as a latching signal in the peripheral device if desired. The Ready signal will remain active until (1) a positive edge is received from the strobe line indicating that the peripheral has taken the data, or (2) if already active, Ready will be forced low 1½ Φ cycles after the leading edge of \overline{IORQ} if the port's output register is written into. Ready will return high on the first falling edge of Φ after the trailing edge of \overline{IORQ} . This guarantees that Ready is low when port data is changing. The Ready signal will not go inactive until a falling edge occurs on the clock (Φ) line. The purpose of delaying the negative transition of the Ready signal until after a negative clock transition is that it allows for a very simple generation scheme for the strobe pulse. By merely connecting the Ready line to the Strobe line, a strobe with a duration of one clock period will be generated with no other logic required. The positive edge of the strobe pulse automatically generates an INT request if the interrupt enable flip flop has been set and this device is the highest priority device requesting an interrupt.

If the PIO is not in a reset state, the output register may be loaded before mode 0 is selected. This allows the port output lines to be permanently active in a user defined state.

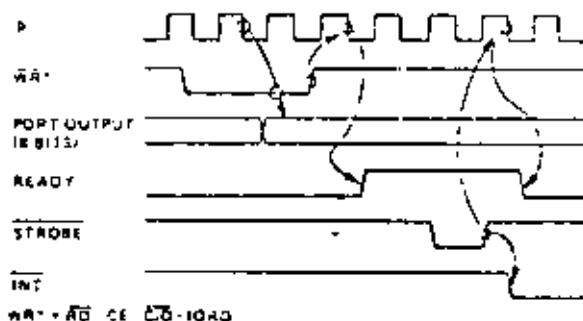

FIGURE 5.0-1
MODE 0 (OUTPUT) TIMING

5.2 INPUT MODE (MODE 1)

Figure 5.0-2 illustrates the timing of an input cycle. The peripheral initiates this cycle using the strobe line after the CPU has performed a data read. A low level on this line loads data into the port input register and the rising edge of the strobe line activates the interrupt request line (INT) if the interrupt enable is set and this is the highest priority requesting device. The next falling edge of the clock line (Φ) will then reset the Ready line to an inactive state signifying that the input register is full and further loading must be inhibited until the CPU reads the data. The CPU will in the course of its interrupt service routine, read the data from the interrupting port. When this occurs, the positive edge from the CPU \overline{RD} signal will raise the Ready line with the next low going transition of Φ , indicating that new data can be loaded into the PIO. If already active, Ready will be forced low one and one half Φ periods following the leading edge of \overline{IORQ} during a read of a PIO port. If the user strobes data into the PIO only when Ready is high, the forced state of Ready will prevent input register data from changing while the CPU is reading the PIO. Ready will go high again after the trailing edge of the \overline{IORQ} as previously described.

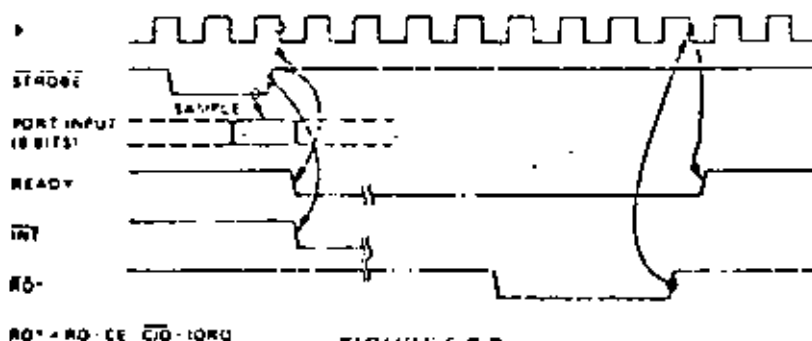

FIGURE 5.0-2
MODE 1 (INPUT) TIMING

5.3 BIDIRECTIONAL MODE (MODE 2)

This mode is merely a combination of Mode 0 and Mode 1 using all four handshake lines. Since it requires all four lines, it is available only on Port A. When this mode is used on Port A, Port B must be set to the Bit Control Mode. The same interrupt vector will be returned for a Mode 3 interrupt on Port B and an input transfer interrupt during Mode 2 operation on Port A. Ambiguity is avoided if Port B is operated in a polled mode and the Port B mask register is set to inhibit all bits.

Figure 5.0-3 illustrates the timing for this mode. It is almost identical to that previously described for Mode 0 and Mode 1 with the Port A handshake lines used for output control and the Port B lines used for input control. The difference between the two modes is that, in Mode 2, data is allowed out onto the bus only when the A STB is low. The rising edge of this strobe can be used to latch the data into the peripheral since the data will remain stable until after this edge. The input portion of Mode 2 operates identically to Mode 1. Note that both Port A and Port B must have their interrupts enabled to achieve an interrupt driven bidirectional transfer.

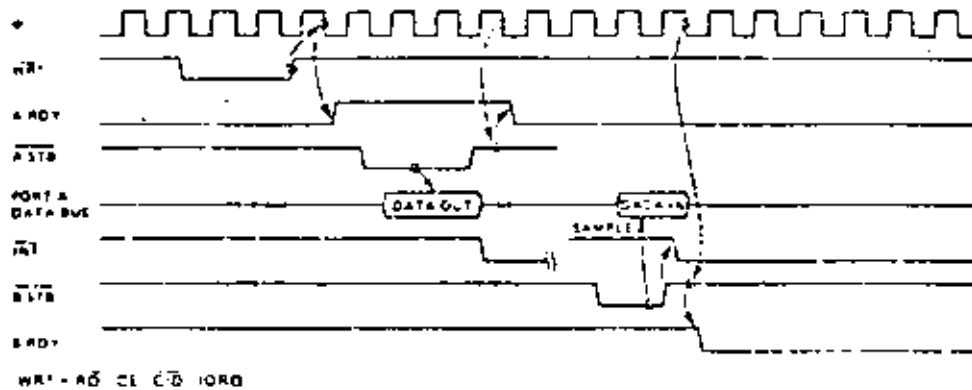

FIGURE 5.0-3
PORT A, MODE 2 (BIDIRECTIONAL) TIMING

The peripheral must not gate data onto a port data bus while A STB is active. Bus contention is avoided if the peripheral uses B STB to gate input data onto the bus. The PIO uses the B STB low level to latch this data. The PIO has been designed with a zero hold time requirement for the data when latching in this mode so that this simple gating structure can be used by the peripheral. That is, the data can be disabled from the bus immediately after the strobe rising edge.

5.4 CONTROL MODE (MODE 3)

The control mode does not utilize the handshake signals and a normal port write or port read can be executed at any time. When writing, the data will be latched into output registers with the same timing as Mode 0. A RDY will be forced low whenever Port A is operated in Mode 3. B RDY will be held low whenever Port B is operated in Mode 3 unless Port A is in Mode 2. In the latter case, the state of B RDY will not be affected.

When reading the PIO, the data returned to the CPU will be composed of output register data from those port data lines assigned as outputs and input register data from those port data lines assigned as inputs. The input register will contain data which was present immediately prior to the falling edge of RD. See Figure 5.0-4.

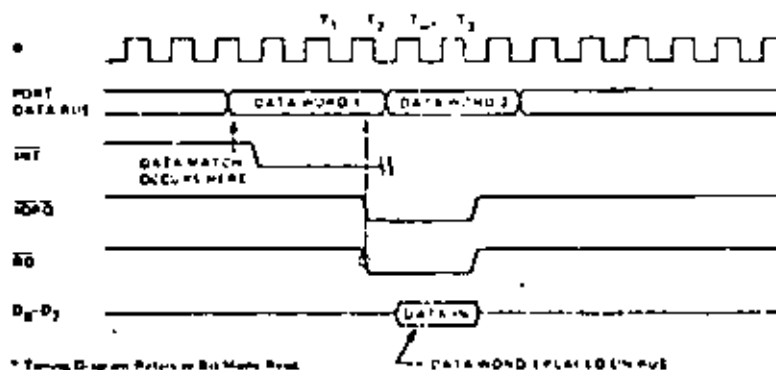

FIGURE 5.0-4

An interrupt will be generated if interrupts from the port are enabled and the data on the port data line satisfies the logical equation defined by the 8-bit mask and 2-bit mask control registers. Another interrupt will not be generated until a change occurs in the status of the logical equation. A Mode 3 interrupt will be generated only if the result of a Mode 3 logical operation changes from false to true. For example, assume that the Mode 3 logical equation is an "OR" function. An unmasked port data line becomes active and an interrupt is requested. If a second unmasked port data line becomes active concurrently with the first, a new interrupt will not be requested since a change in the result of the Mode 3 logical operation has not occurred.

If the result of a logical operation becomes true immediately prior to or during $\overline{M1}$, an interrupt will be requested after the trailing edge of $\overline{M1}$.

6.0 INTERRUPT SERVICING

Some time after an interrupt is requested by the PIO, the CPU will send out an interrupt acknowledge ($\overline{M1}$ and \overline{IORQ}). During this time the interrupt logic of the PIO will determine the highest priority port which is requesting an interrupt. (This is simply the device with its Interrupt Enable Input high and its Interrupt Enable Output low). To insure that the daisy chain enable lines stabilize, devices are inhibited from changing their interrupt request status when $\overline{M1}$ is active. The highest priority device places the contents of its interrupt vector register onto the Z80 data bus during interrupt acknowledge.

Figure 6.0-1 illustrates the timing associated with interrupt requests. During $\overline{M1}$ time, no new interrupt requests can be generated. This gives time for the \overline{Int} Enable signals to ripple through up to four PIO circuits. The PIO with \overline{IEI} high and \overline{IEO} low during \overline{INTA} will place the 8-bit interrupt vector of the appropriate port on the data bus at this time.

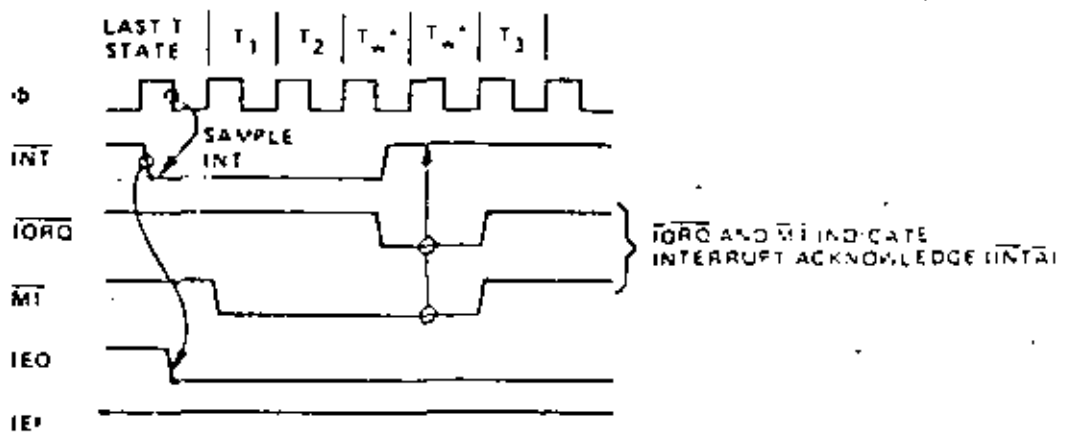

FIGURE 6.0-1
INTERRUPT ACKNOWLEDGE TIMING

If an interrupt requested by the PIO is acknowledged, the requesting port is 'under service'. \overline{IEO} of this port will remain low until a return from interrupt instruction (RETI) is executed while \overline{IEI} of the port is high. If an interrupt request is not acknowledged, \overline{IEO} will be forced high for one $\overline{M1}$ cycle after the PIO decodes the opcode 'ED'. This action guarantees that the two byte RETI instruction is decoded by the proper PIO port. See Figure 6.0-2.

Figure 6.0-3 illustrates a typical nested interrupt sequence that could occur with four ports connected in the daisy chain. In this sequence Port 2A requests and is granted an interrupt. While this port is being serviced, a higher priority port (1B) requests and is granted an interrupt. The service routine for the higher priority port is completed and a RETI instruction is executed to indicate to the port that its routine is complete. At this time the service routine of the lower priority port is completed.

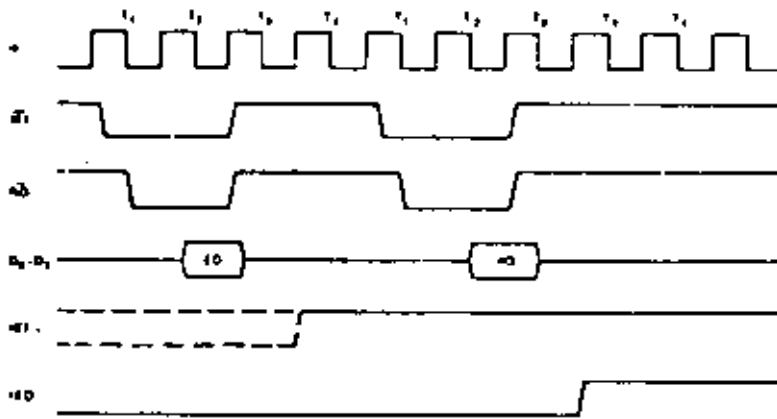

FIGURE 6.0-2
RETURN FROM INTERRUPT CYCLE

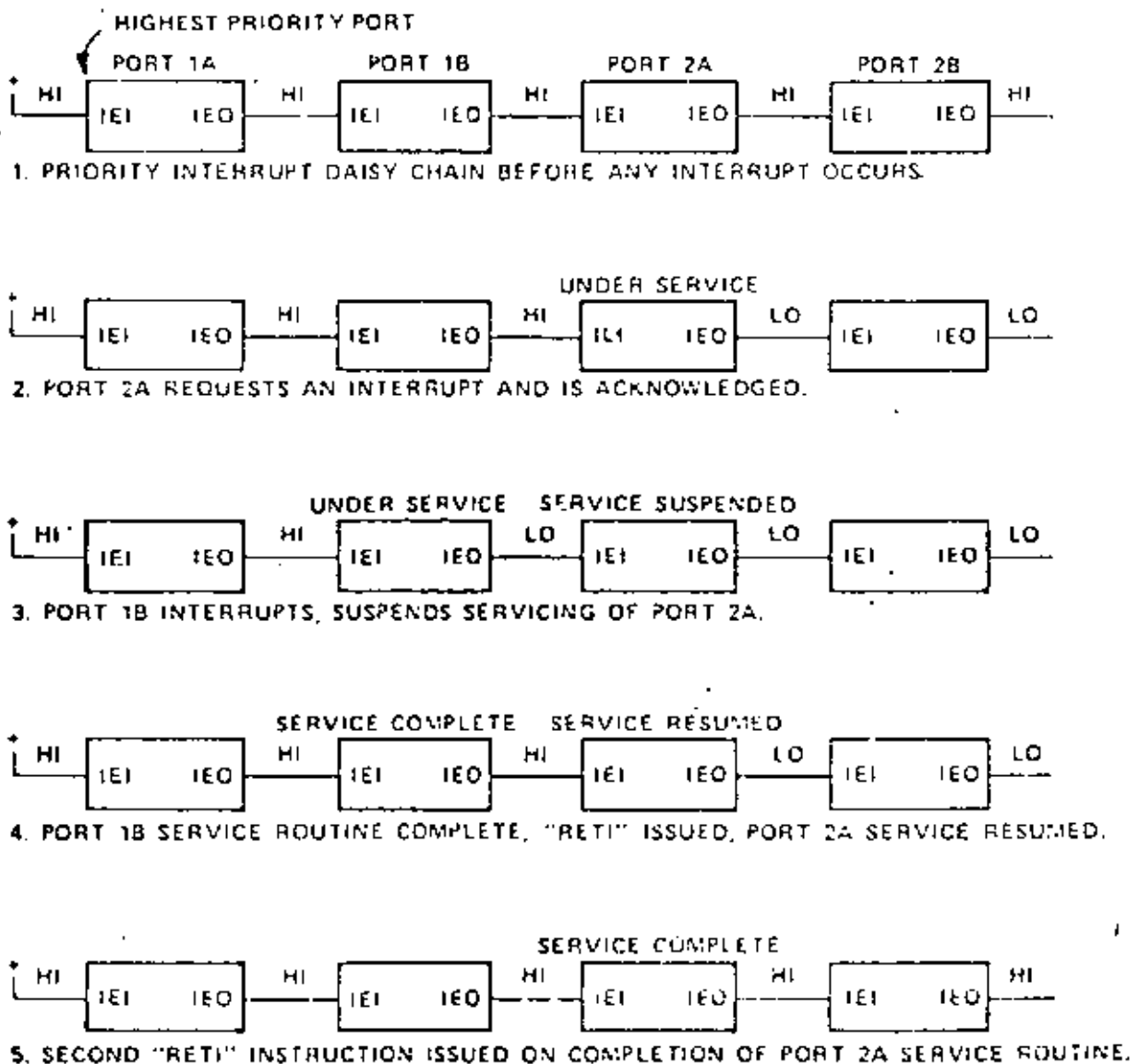

FIGURE 6.0-3
DAISY CHAIN INTERRUPT SERVICING

7.0 APPLICATIONS

7.1 EXTENDING THE INTERRUPT DAISY CHAIN

Without any external logic, a maximum of four Z80-PIO devices may be daisy chained into a priority interrupt structure. This limitation is required so that the interrupt enable status (\overline{IEO}) applies through the entire chain between the beginning of \overline{MI} , and the beginning of \overline{IORQ} during an interrupt acknowledge cycle. Since the interrupt enable status cannot change during \overline{MI} , the vector address returned to the CPU is assured to be from the highest priority device which requested an interrupt.

If more than four PIO devices must be accommodated, a "look-ahead" structure may be used as shown in Figure 7.0-1. With this technique more than thirty PIO's may be chained together using standard TTL logic.

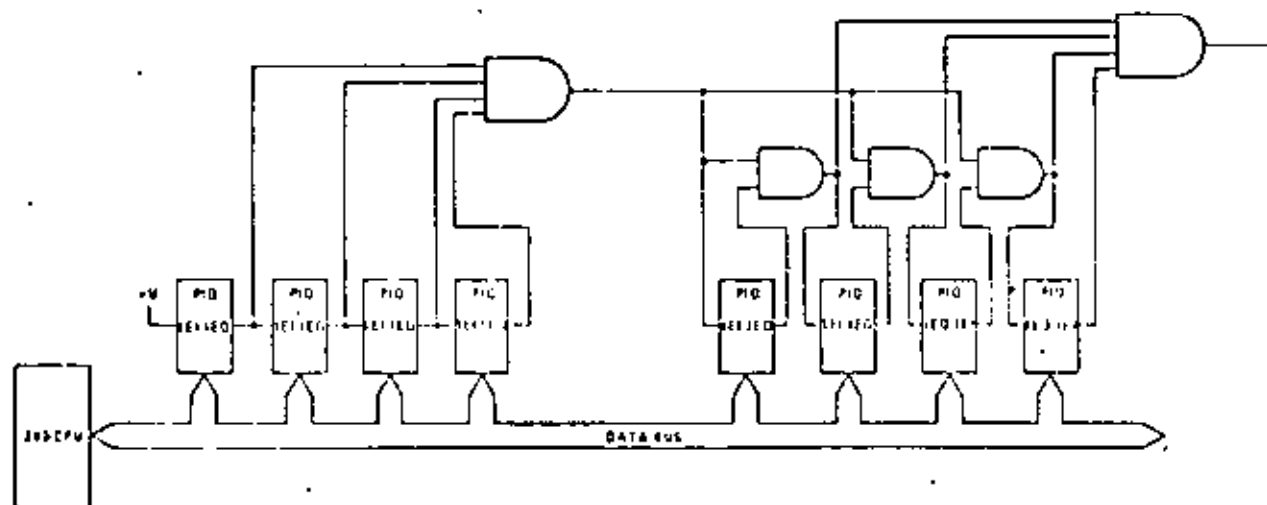
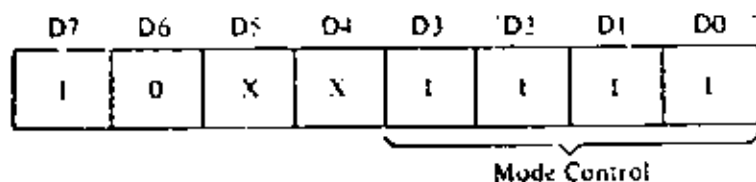

FIGURE 7.0-1
A METHOD OF EXTENDING THE INTERRUPT PRIORITY DAISY CHAIN

7.2 I/O DEVICE INTERFACE

In this example, the Z80-PIO is connected to an I/O terminal device which communicates over an 8 bit parallel bidirectional data bus as illustrated in Figure 7.0-2. Mode 2 operation (bidirectional) is selected by sending the following control word to Port A:



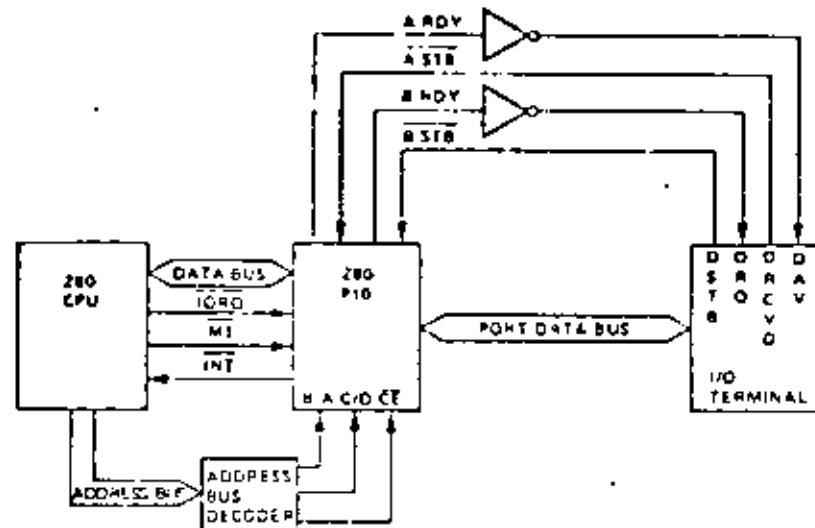

FIGURE 7.0-2

EXAMPLE I/O INTERFACE

Next, the proper interrupt vector is loaded (refer to CPU Manual for details on the operation of the interrupt).

D7	D6	D5	D4	D3	D2	D1	D0
V7	V6	V5	V4	V3	V2	V1	0

Interrupts are then enabled by the rising edge of the first $\overline{M1}$ after the interrupt mask word is set unless that $\overline{M1}$ defines an interrupt acknowledge cycle. If a mask follows the interrupt mask word, interrupts are enabled by the rising edge of the first $\overline{M1}$ following the setting of the mask.

Data can now be transferred between the peripheral and the CPU. The timing for this transfer is as described in Section 5.0.

7.3 CONTROL INTERFACE

A typical control mode application is illustrated in Figure 7.0-3. Suppose an industrial process is to be monitored. The occurrence of any abnormal operating condition is to be reported to a Z80-CPU based control system. The process control and status word has the following format:

D7	D6	D5	D4	D3	D2	D1	D0
Special Test	Turn On Power	Power Failure Alarm	Halt Processing	Temp. Alarm	Turn Heaters On	Pressure System	Pressure Alarm

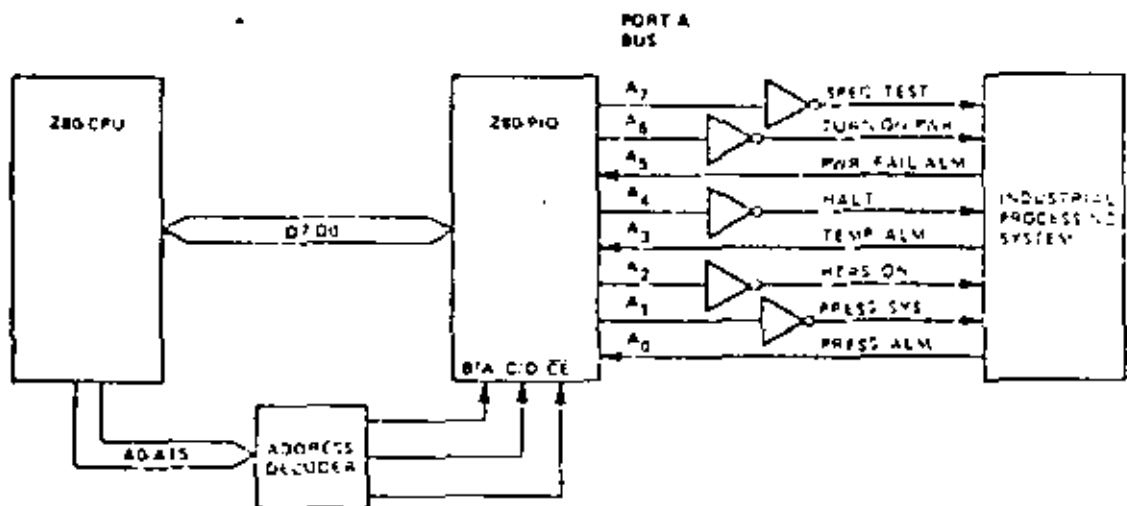

FIGURE 7.0-3
CONTROL MODE APPLICATION

The PIO may be used as follows. First Port A is set for Mode 3 operation by writing the following control word to Port A.

D7	D6	D5	D4	D3	D2	D1	D0
1	1	X	X	1	1	1	1

Whenever Mode 3 is selected, the next control word sent to the port must be an I/O select word. In this example we wish to select port data lines A5, A3 and A0 as inputs and so the following control word is written: -

D7	D6	D5	D4	D3	D2	D1	D0
0	0	1	0	1	0	0	1

Next the desired interrupt vector must be loaded (refer to the CPU manual for details).

D7	D6	D5	D4	D3	D2	D1	D0
V7	V6	V5	V4	V3	V2	V1	0

An interrupt control word is next sent to the port:

D7	D6	D5	D4	D3	D2	D1	D0
1	0	1	1	0	1	1	1
Enable Interrupts	OR Logic	Active High	Mask Follows	Interrupt control			

The mask word following the interrupt mode word is:

D7	D6	D5	D4	D3	D2	D1	D0
1	1	0	1	0	1	1	0
Selects A5, A3 and A0 to be monitored							

Now, if a sensor puts a high level on line A5, A3, or A0, an interrupt request will be generated. The mask word may select any combination of inputs or outputs to cause an interrupt. For example, if the mask word above had been:

D7	D6	D5	D4	D3	D2	D1	D0
0	1	0	1	0	1	1	0

then an interrupt request would also occur if bit A7 (Special Test) of the output register was set.

Assume that the following port assignments are to be used:

- E0_H = Port A Data
- E1_H = Port B Data
- E2_H = Port A Control
- E3_H = Port B Control

All port numbers are in hexadecimal notation. This particular assignment of port numbers is convenient since A₀ of the address bus can be used as the Port B/A Select and A₁ of the address bus can be used as the Control/Data Select. The Chip Enable would be the decode of CPU address bits A₇ thru A₅ (1110 00). Note that if only a few peripheral devices are being used, a Chip Enable decode may not be required since a higher order address bit could be used directly.



8.0 PROGRAMMING SUMMARY

8.1 LOAD INTERRUPT VECTOR

V7	V6	V5	V4	V3	V2	V1	0
----	----	----	----	----	----	----	---

8.2 SET MODE

M1	M0	X	X	1	1	1	1
----	----	---	---	---	---	---	---

M ₁	M ₀	Mode
0	0	Output
0	1	Input
1	0	Bidirectional
1	1	Bit Control

When selecting Mode 3, the next word must set the I/O Register

I/O ₇	I/O ₆	I/O ₅	I/O ₄	I/O ₃	I/O ₂	I/O ₁	I/O ₀
------------------	------------------	------------------	------------------	------------------	------------------	------------------	------------------

I/O = 1 Sets bit to Input

I/O = 0 Sets bit to Output

8.3 SET INTERRUPT CONTROL

Int Enable	AND OR	High / Low	Mask Follows	0	1	1	1
------------	--------	------------	--------------	---	---	---	---

Used in Mode 3 only

If the "mask follows" bit is high, the next control word written to the port must be the mask:

MB ₇	MB ₆	MB ₅	MB ₄	MB ₃	MB ₂	MB ₁	MB ₀
-----------------	-----------------	-----------------	-----------------	-----------------	-----------------	-----------------	-----------------

MB = 0, Monitor bit

MB = 1, Mask bit from being monitored

Also, the interrupt enable flip flop of a port may be set or reset without modifying the rest of the interrupt control word by using the following command.

Int Enable	X	X	X	0	0	1	1
------------	---	---	---	---	---	---	---



Temperature (under bias)	Specified operating range
Storage Temperature	-65°C to +150°C
Voltage-On V _{CC} Pin With Respect To Terminal 3	-0.5 V to +7 V
Power Dissipation	0.5 W

***Comment**

Stresses above those listed under "Absolute Maximum Rating" may cause permanent damage to the device. This is a stress rating only and not a recommendation of the device at these or any other conditions above those indicated in the operational sections of this specification. Failure is not implied. Exposure to absolute maximum rating conditions for extended periods may affect device reliability.

Note: All AC and DC characteristics remain the same for the military grade parts except I_{OL}.

I_{OL} = 130 mA

Z80-PIO and Z80A-PIO D.C. Characteristics

T_A = 0°C to 70°C, V_{CC} = 5 V ± 5%, unless otherwise specified.

Symbol	Parameter	Min.	Max.	Unit	Test Condition
V _{ILC}	Clock Input Low Voltage	-0.5	0.5	V	
V _{IHC}	Clock Input High Voltage	V _{CC} - 0.4	V _{CC} + 0.3	V	
V _{IL}	Input Low Voltage	-0.5	0.8	V	
V _{IH}	Input High Voltage	2.0	V _{CC}	V	
V _{OL}	Output Low Voltage		0.4	V	I _{OL} = 10 mA
V _{OH}	Output High Voltage	2.4		V	I _{OH} = -250 μA
I _{CC}	Power Supply Current		70	mA	
I _{IL}	Input Leakage Current		10	μA	V _{IN} = 0 to V _{CC}
I _{LOH}	Tri-State Output Leakage Current in High		10	μA	V _{OL} = 2.4 to V _{CC}
I _{LOL}	Tri-State Output Leakage Current in Low		-10	μA	V _{OH} = 2.4 V
I _{LD}	Data Bus Leakage Current in Input Mode		±10	μA	0 ≤ V _{IN} ≤ V _{CC}
I _{OH}	Disturbance Drive Current	-1.5	3.4	mA	V _{OH} = 2.5 V R _{EXT} = 200 Ω P _{EXT} = 0.01 μs

Package Configuration

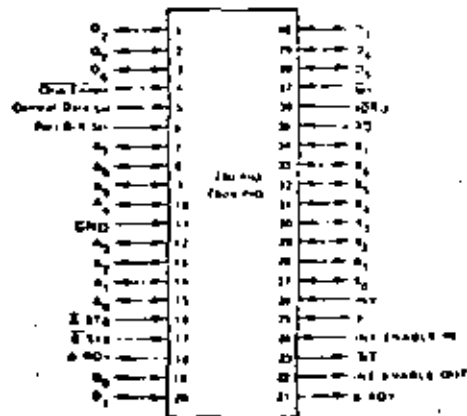

Package Outline

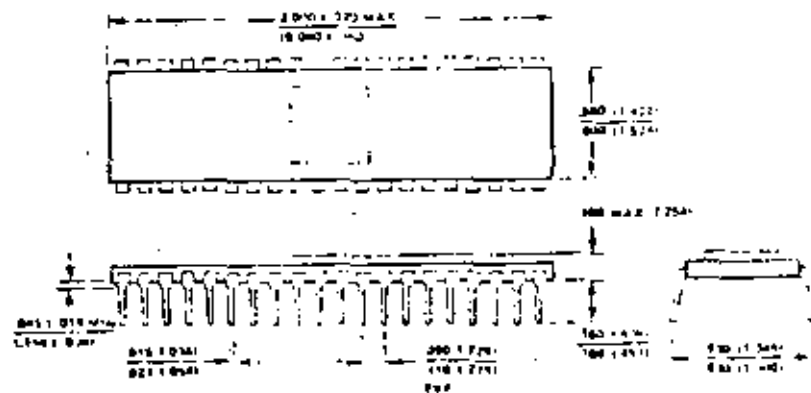

NOTE: Dimensions in parentheses are for metric system (cm).

TA = 0°C to 70°C, VCC = +5 V ± 5%, unless otherwise noted

CHAR.	SYMBOL	PARAMETER	MIN.	MAX.	UNIT	COMMENTS
t	t _{CL}	Clock Period	400	11 ¹⁾	nan	
	t _{CL(HIGH)}	Clock Pulse Width (Clock High)	170	2300	nan	
	t _{CL(LOW)}	Clock Pulse Width (Clock Low)	170	2100	nan	
	t _{CL}	Clock Rise and Fall Times		30	nan	
t _{su}		Any Hold Time prior to Setup and Set Up Time	0		nan	
CS, CE, ETC.	t _{su} (CS)	Control Signal Set Up Time to Rising Edge and During Read or Write Cycle	280		nan	
D ₀ D ₇	t _{DR (DI)}	Data Output Delay from Falling Edge of \overline{RD}	50	480	nan	C _L = 50 pF
	t _{DR (DO)}	Data Set Up Time to Rising Edge of \overline{RD} During Write or \overline{MS} Cycle		140	nan	
	t _{DR (DI)}	Data Output Delay from Falling Edge of \overline{RD} During INTA Cycle		160	nan	
IEI	t _{su} (IEI)	IEI Set Up Time to Falling Edge of \overline{RD} During INTA Cycle	140		nan	
	t _{DR (IEI)}	IEI Delay Time from Rising Edge of IEI		210	nan	C _L = 50 pF
t _{DR (IEI)}	IEI Delay Time from Falling Edge of IEI		190	nan		
t _{DR (IEI)}	IEI Delay Time from Falling Edge of \overline{MS} After \overline{RD} Occurring Just Prior to \overline{MS} . See Note A.			200	nan	
\overline{RD}	t _{su} (RD)	\overline{RD} Set Up Time to Rising Edge of \overline{RD} During Read or Write Cycle	250		nan	
\overline{MS}	t _{su} (MS)	\overline{MS} Set Up Time to Rising Edge of \overline{RD} During INTA or \overline{MS} Cycle. See Note B.	210		nan	
\overline{RD}	t _{su} (RD)	\overline{RD} Set Up Time to Falling Edge of \overline{RD} During Read or \overline{MS} Cycle	240		nan	
A ₀ A ₇ B ₀ B ₇	t _{su} (PD)	Par. Data Set Up Time to Rising Edge of \overline{STROBE} (Mode 1)	260		nan	C _L = 50 pF
	t _{su} (PD)	Par. Data Output Delay from Falling Edge of \overline{STROBE} (Mode 2)		230	nan	
	t _{su} (PD)	Delay to Floating Par. Data Bus from Falling Edge of \overline{STROBE} (Mode 2)		200	nan	
	t _{su} (PD)	Par. Data Delay from Rising Edge of \overline{RD} During WR Cycle (Mode 3)		200	nan	
A ₅ B ₅ B ₅ B ₇	t _{su} (ST)	Pulse Width \overline{STROBE}	150		nan	
	t _{su} (ST)		14		nan	
INT	t _{DR (INT)}	INT Delay Time from Rising Edge of \overline{STROBE}		490	nan	
	t _{DR (INT)}	INT Delay Time from Data Strobe During Mode 3 Operation		420	nan	
ARDV, BRDV	t _{DR (RDV)}	Ready Response Time from Rising Edge of \overline{RD}		1 μ ²⁾ 460	nan	C _L = 50 pF
	t _{DR (RDV)}	Ready Response Time from Rising Edge of \overline{STROBE}		1 μ ²⁾ 400	nan	

NOTES:

A. 25 t_{CL} > t_{DR (DI)} > t_{DR (DO)} > t_{DR (IEI)} > t_{su} (IEI) > TTL Buffer Delay, if any.

B. \overline{MS} must be active for a minimum of 2 clock periods to reset the PIO.

Output load circuit.

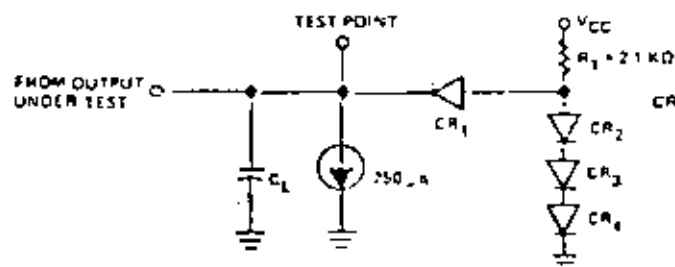

CR₁ - CR₄ (N314 OR EQUIVALENT)

C_L = 50 pF ON D₀, D₇
= 50 pF ON ALL OTHERS

1) t_{CL} = t_{CL(HIGH)} + t_{CL(LOW)} + t_{CL}

2) Indicate t_{DR (DI)} & t_{DR (DO)} time for each 50 pF increase in loading up to 200 pF max.

3) Increase t_{DR (DI)} by 70 ns for each 50 pF increase in loading up to 200 pF max.

4) For Mode 2, t_{su} (ST) > t_{su} (PD)

5) Increase these values by 20% for each 10 pF increase in loading up to 100 pF max.

Capacitance

TA = 25°C, f = 1 MHz

Symbol	Parameter	Max.	Unit	Test Condition
C ₀	Clock Capacitance	10	pF	Unmeasured Pins Returned to Ground
C _{IN}	Input Capacitance	5	pF	
C _{OUT}	Output Capacitance	10	pF	

Timing measurements are made at the following voltages, unless otherwise specified

	"1"	"0"
CLOCK	$V_{CC} - 0.5$	45V
OUTPUT	2.0V	0.8V
INPUT	2.0V	0.8V
FLOAT	4V	0.5V

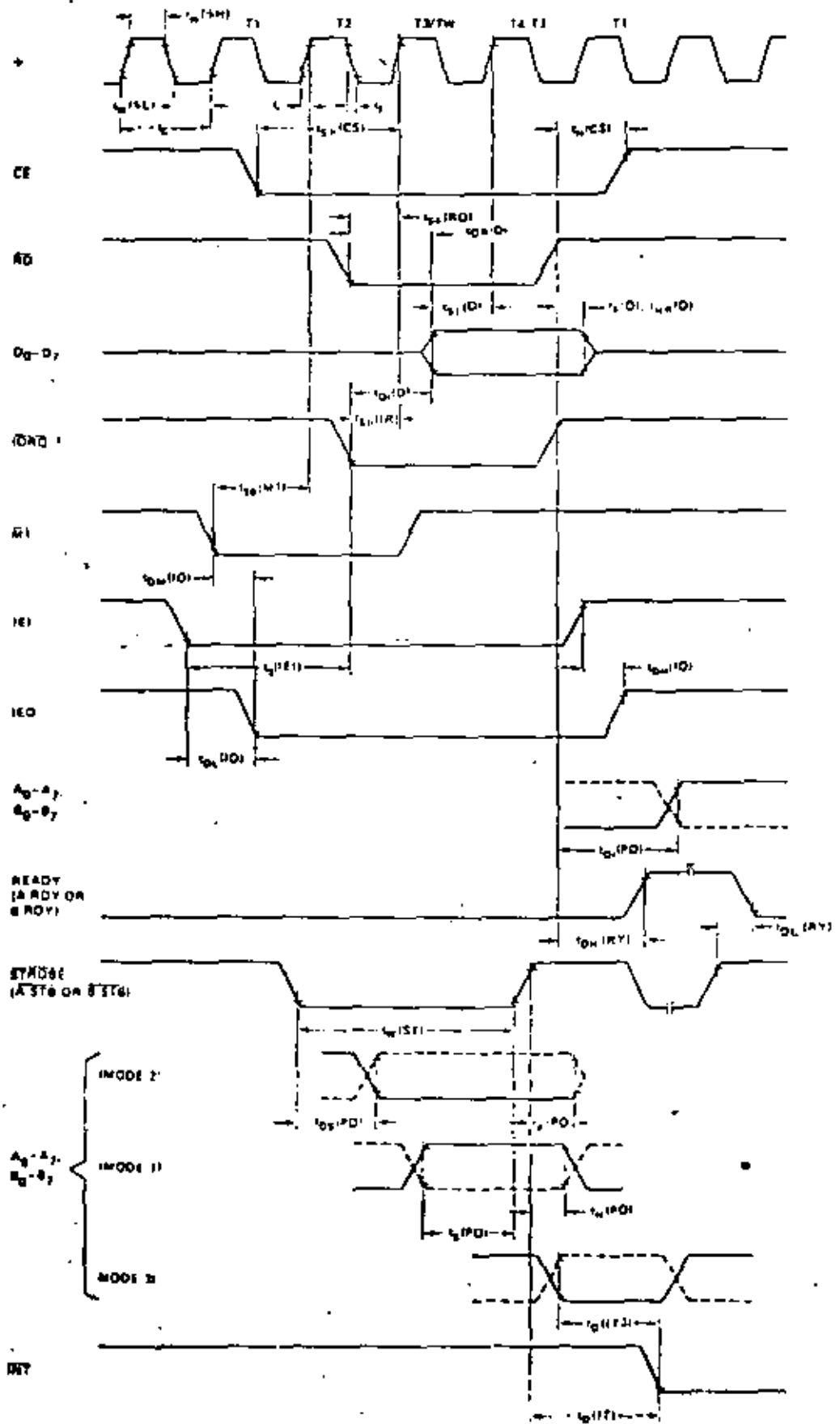

Z-80[®] SIO

97

TECHNICAL MANUAL

A.C. Characteristics

Z80A PIO

96

TA = 0° C to 70° C, VCC = +5 V ± 5%, unless otherwise noted

SIGNAL	SYMBOL	PARAMETER	MIN	MAX	UNIT	COMMENTS
φ	t _c	Clock Period	250	131	nsec	
	t _w (φH)	Clock Pulse Width, Clock High	105	2000	nsec	
	t _w (φL)	Clock Pulse Width, Clock Low	105	2000	nsec	
	t _r	Clock Rise and Fall Times		30	nsec	
	t _h	Any Hold Time for Setup and Set Up Times	0		nsec	
CS, CT, ETC	t _{su} (CS)	Control Signal Set Up Time to Rising Edge of φ During Read or Write Cycle	145		nsec	
D ₀ -D ₇	t _{OR} (D _i)	Data Output Delay from Falling Edge of φD		360	nsec	[2]
	t _{su} (D _i)	Data Set Up Time to Rising Edge of φ During Write or φ _W Cycle	50		nsec	C _L = 50 pF
	t _{DI} (D _i)	Data Output Delay from Falling Edge of φD ₀ During INTA Cycle		250	nsec	[3]
	t _h (D _i)	Delay to Floating Data Bus Output Buffer Disable Times		170	nsec	
MEM	t _{su} (MEM)	MEM Set Up Time to Falling Edge of φD ₀ During INTA Cycle	140		nsec	
MEM	t _{DM} (MEM)	MEM Delay Time from Rising Edge of MEM		160	nsec	[5]
	t _{DL} (MEM)	MEM Delay Time from Falling Edge of MEM		130	nsec	5 C _L = 100 pF
	t _{DM} (MEM)	MEM Delay from Falling Edge of MEM (Minimum Occurring Just Prior to φT1; See Note A)		190	nsec	[5]
φRD	t _{su} (φRD)	φRD Set Up Time to Rising Edge of φ During Read or Write Cycle	116		nsec	
φM1	t _{su} (φM1)	φM1 Set Up Time to Rising Edge of φ During INTA or M1 Cycle. See Note B	90		nsec	
φD	t _{su} (φD)	φD Set Up Time to Rising Edge of φ During Read or M1 Cycle	115		nsec	
A ₀ -A ₇ , B ₀ -B ₇	t _{su} (A _i)	Port Data Set Up Time to Rising Edge of STROBE (Mode 1)	230		nsec	[5]
	t _{su} (B _i)	Port Data Output Delay from Falling Edge of STROBE (Mode 2)		210	nsec	
	t _r (A _i)	Delay to Floating Port Data Bus from Rising Edge of STROBE (Mode 2)		180	nsec	C _L = 50 pF
	t _{DI} (A _i)	Port Data Stable from Rising Edge of φD ₀ During WR Cycle (Mode 0)		180	nsec	[5]
ASTB, B5TB	t _w (STB)	Pulse Width STROBE	150	[4]	nsec	
INT	t _{DI} (INT)	INT Delay Time from Rising Edge of STROBE		440	nsec	
	t _{DI} (INT)	INT Delay Time from Data Match During Mode 3 Operation		360	nsec	
ARDY, BRDY	t _{DM} (ARDY)	Ready Response Time from Rising Edge of φRD		4 _μ	nsec	[5]
	t _{DL} (ARDY)	Ready Response Time from Rising Edge of STROBE		4 _μ	nsec	C _L = 50 pF

NOTES:

- A. $2.5 t_{c} > (t_{OR}(D_i) + t_{su}(D_i) + t_{DI}(D_i) + t_{h}(D_i)) + TTL$ Buffer Delay, if any
 B. INT must be active for a maximum of 2 clock periods to reset the PIO

- [1] $t_{c} = t_{w}(\phi H) + t_{w}(\phi L) + t_{r}$
 [2] Increase t_{OR}(D_i) by 10 nsec for each 50 pF increase in loading up to 200 pF max
 [3] Increase t_{DI}(D_i) by 10 nsec for each 50 pF increase in loading up to 200 pF max
 [4] For Mode 2, t_w(STB) > 15 nsec
 [5] Increase these values by 2 nsec for each 10 pF increase in loading up to 100 pF max

Z-80 SIO
TECHNICAL MANUAL

Z80-SIO Technical Manual ⁹⁹

Contents

General Information	1
Pin Description	2
Architecture	5
The Data Path	5
Functional Description	7
Asynchronous Operation	9
Asynchronous Transmit	9
Asynchronous Receive	10
Synchronous Operation	13
Synchronous Transmit	14
Synchronous Receive	17
SDLC (HDLC) Operation	21
SDLC Transmit	21
SDLC Receive	25
Z80-SIO Programming	29
Write Registers	29
Read Registers	34
Applications	39
Timing	41

The Z80-SIO (Serial Input/Output) is a dual-channel multi-function peripheral component designed to satisfy a wide variety of serial data communications requirements in microcomputer systems. Its basic function is a serial-to-parallel, parallel-to-serial converter/controller, but—within that role—it is configurable by systems software so its "personality" can be optimized for a given serial data communications application.

The Z80-SIO is capable of handling asynchronous and synchronous byte-oriented protocols such as IBM Bisync, and synchronous bit-oriented protocols such as

HDLC and IBM SDLC. This versatile device can also be used to support virtually any other serial protocol for applications other than data communications (cassette or floppy disk interfaces, for example).

The Z80-SIO can generate and check CRC codes in any synchronous mode and can be programmed to check data integrity in various modes. The device also has facilities for modem controls in both channels. In applications where these controls are not needed, the modem controls can be used for general-purpose I/O.

STRUCTURE

- N-channel silicon-gate depletion-load technology
- 40-pin DIP
- Single 5 V power supply
- Single-phase 5 V clock
- All inputs and outputs TTL compatible

FEATURES

- Two independent full-duplex channels
- Data rates in synchronous or isosynchronous modes:

- 0-550K bits/second with 2.5 MHz system clock rate

- 0-880K bits/second with 4.0 MHz system clock rate

- Receiver data registers quadruply buffered; transmitter doubly buffered.

■ Asynchronous features:

- 5, 6, 7 or 8 bits/character
- 1, 1.5 or 2 stop bits
- Even, odd or no parity
- 1, 16, 32 and 64 clock modes
- Break generation and detection
- Parity, overrun and framing error detection

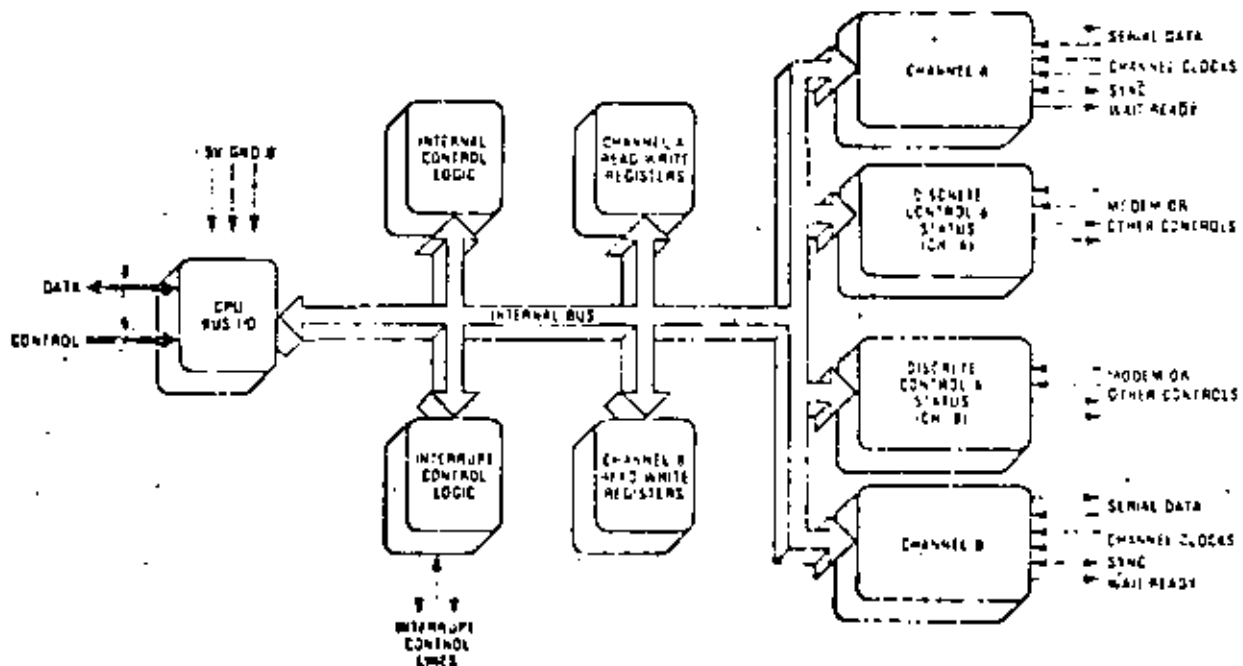

Z80-SIO BLOCK DIAGRAM

- Binary synchronous features:
 - Internal or external character synchronization
 - One or two sync characters in separate registers
 - Automatic sync character insertion
 - CRC generation and checking
- HDL C and IBM SDLC features:
 - Abort sequence generation and detection
 - Automatic zero insertion and deletion
 - Automatic flag insertion between messages
 - Address field recognition
 - I-field residue handling
 - Valid receive messages protected from overrun
 - CRC generation and checking
- Separate modem control inputs and outputs for both channels
- CRC-16 or CRC-CCITT block check
- Daisy-chain priority interrupt logic provides automatic interrupt vectoring without external logic
- Modem status can be monitored

Pin Description

D₀-D₇. *System Data Bus* (bidirectional, 3-state). The system data bus transfers data and commands between CPU and the Z80-SIO. D₀ is the least significant bit.

B/A. *Channel A Or B Select* (input, High selects Channel A, Low selects Channel B). This input defines which channel is accessed

during a data transfer between the CPU and the Z80-SIO. Address bit A₀ from the CPU is often used for the selection function.

C/D. *Control Or Data Select* (input, High selects Control). This input defines the type of information transfer performed between the CPU and the Z80-SIO. A High at this input during a CPU write to the Z80-SIO causes the information on the data bus to be interpreted as a command for the channel selected by B/A. A Low at C/D means that the information on the data bus is data. Address bit A₁ is often used for this function.

CE. *Chip Enable* (input, active Low). A Low level at this input enables the Z80-SIO to accept commands or data inputs from the CPU during a write cycle, or to transmit data to the CPU during a read cycle.

φ. *System Clock* (input). The Z80-SIO uses the standard Z80A System Clock to synchronize internal signals. This is a single-phase clock.

MI. *Machine Cycle One* (input from Z80-CPU, active Low). When MI is active and RD is also active, the Z80-CPU is fetching an instruction from memory; when MI is active while WRQ is active, the Z80-SIO accepts RD and IORQ as an interrupt acknowledge if the Z80-SIO is the highest priority device that has interrupted the Z80-CPU.

IORQ. *Input/Output Request* (input from CPU, active Low). IORQ is used in conjunction with B/A, C/D, CE and RD to transfer commands and data between the CPU and the Z80-SIO. When CE, RD and IORQ are all active,

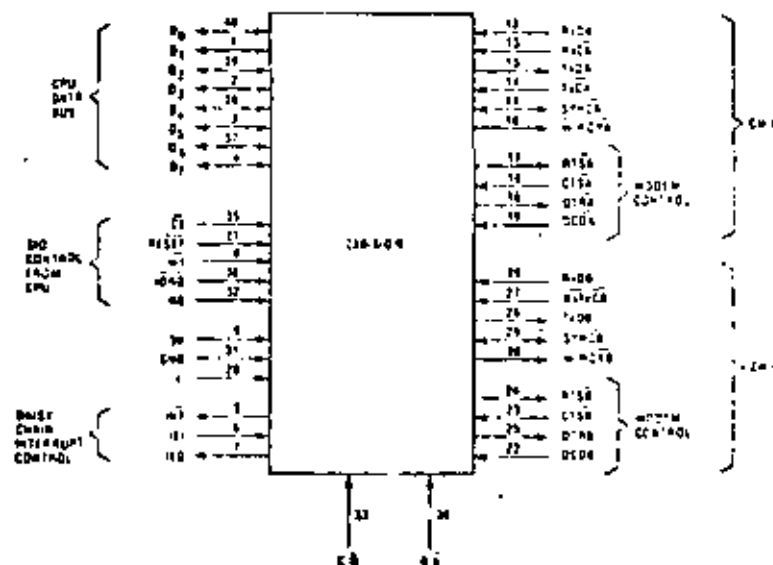

Figure 1. Z80 SIO Pin Configuration

the channel selected by \overline{CS} is used to transfer data to the CPU (a read operation). When \overline{OE} and \overline{WE} are active, but \overline{RD} is inactive, the channel selected by \overline{CS} is written to by the CPU with either data or control information as specified by \overline{CD} . As mentioned previously, if \overline{INT} and \overline{RD} are active simultaneously, the CPU is acknowledging an interrupt and the Z80-SIO automatically places its interrupt vector on the CPU data bus if it is the highest priority device requesting an interrupt.

\overline{RD} . Read Cycle Status. (input from CPU, active Low). If \overline{RD} is active, a memory or I/O read operation is in progress. \overline{RD} is used with \overline{BA} , \overline{CE} and \overline{IORQ} to transfer data from the Z80-SIO to the CPU.

\overline{RESET} . Reset (input, active Low). A Low \overline{RESET} disables both receivers and transmitters, forces TxD A and TxD B marking, forces the modem controls High and disables all interrupts. The control registers must be rewritten after the Z80-SIO is reset and before data is transmitted or received.

\overline{IEI} . Interrupt Enable In (input, active High). This signal is used with \overline{IEO} to form a priority daisy chain when there is more than one interrupt-driven device. A High on this line indicates that no other device of higher priority is being serviced by a CPU interrupt service routine.

\overline{IEO} . Interrupt Enable Out (output, active High). \overline{IEO} is High only if \overline{IEI} is High and the CPU is not servicing an interrupt from this Z80-SIO. Thus, this signal blocks lower priority devices from interrupting while a higher priority device is being serviced by its CPU interrupt service routine.

\overline{INT} . Interrupt Request (output, open drain, active

Low). When the Z80-SIO is requesting an interrupt, it pulls \overline{INT} Low.

\overline{WRDYA} , \overline{WRDYB} . Wait/Ready A, Wait/Ready B (outputs, open drain when programmed for Wait/Ready function, driven High and Low when programmed for Ready function). These dual-purpose outputs may be programmed as Ready lines for a DMA controller or as Wait lines that synchronize the CPU to the Z80-SIO data rate. The reset state is open drain.

\overline{CISA} , \overline{CISB} . Clear To Send Inputs, active Low). When programmed as Auto Enables, a Low on these inputs enables the respective transmitter. If not programmed as Auto Enables, these inputs may be programmed as general-purpose inputs. Both inputs are Schmitt-trigger buffered to accommodate slow-rising inputs. The Z80-SIO detects pulses on these inputs and interrupts the CPU on both logic level transitions. The Schmitt-trigger inputs do not guarantee a specified noise-level margin.

\overline{DCDA} , \overline{DCDB} . Data Carrier Detect inputs, active Low). These signals are similar to the CTS inputs, except they can be used as receiver enables.

\overline{RDYA} , \overline{RDYB} . Receive Ready inputs, active High.

\overline{TxD} A, \overline{TxD} B. Transmit Data (outputs, active High)

\overline{RXCA} , \overline{RXCB} . Receiver Clocks (inputs). See the following section on timing options. The Receiver Clock may be 1, 16, 32 or 64 times the data rate in asynchronous modes. Receive data is sampled on the rising edge of \overline{RXC} .

*See FR04010E OR NEW PAGE

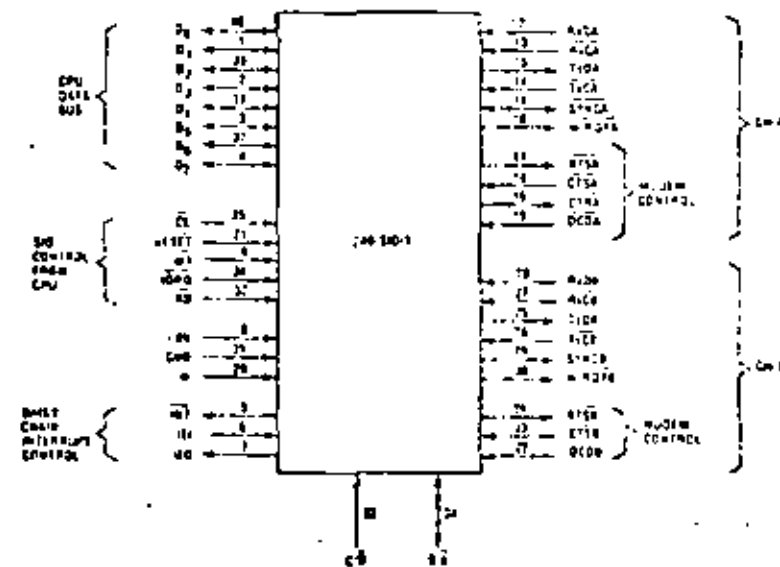

Figure 2. Z80-SIO Pin Configuration

TXDA, TXDB. *Transmitter Clocks* (outputs). See section on bonding options. In the External Sync mode, the transmitter clocks may be 1, 16, 32 or 64 times the data rate. The multiplier for the transmitter and the receiver must be the same. Both the TXC and RXC inputs are Schmitt-trigger buffered for relaxed rise- and fall-time requirements (no noise margin is specified). TXD changes on the falling edge of TXC.

RTSA, RTSB. *Request To Send* (outputs, active Low). When the RTS bit is set, the RTS output goes Low. When the RTS bit is reset in the Asynchronous mode, the output goes High after the transmitter is empty. In Synchronous modes, the RTS pin strictly follows the state of the RTS bit. Both pins can be used as general-purpose outputs.

DTRA, DTRB. *Data Terminal Ready* (outputs, active Low). See note on bonding options. These outputs follow the state programmed into the DTR bit. They can also be programmed as general-purpose outputs.

SYNA, SYNCB. *Synchronization* (inputs/outputs, active Low). These pins can act either as inputs or outputs. In the Asynchronous Receive mode, they are inputs similar to CTS and DTR. In this mode, the transitions on these lines affect the state of the Sync/Hunt status bits in KR0. In the External Sync mode, these lines also act as inputs. When external synchronization is achieved, SYNC must be driven Low on the second rising edge of RXC after that rising edge of RXC on which the first bit of the sync character was received. In other words, after the sync pattern is detected, the external logic must wait for two full Receive Clock cycles to activate the SYNC input. Once SYNC is forced Low, it is wise

to keep it Low until the CPU (500 ns) status logic indicates that synchronization has been lost or a new message is about to start. Character assembly begins on the rising edge of RXC that immediately precedes the falling edge of SYNC in the External Sync mode.

In the Internal Synchronization mode (Microsync and Bisync), these pins act as outputs that are active during the part of the receive clock (RXC) cycle in which sync characters are recognized. The sync condition is not latched, so these outputs are active each time a sync pattern is recognized, regardless of character priorities.

BONDING OPTIONS

The constraints of a 40-pin package make it impossible to bring out the Receive Clock, Transmit Clock, Data Terminal Ready and Sync signals for both channels. Therefore, Channel B must sacrifice a signal or have two signals bonded together. Since user requirements vary, three bonding options are offered:

- Z80-SIO/0 has all four signals, but TXCA and RXCB are bonded together (Fig. 1).
- Z80-SIO/1 sacrifices DTRB and keeps TXCA, TXCB and SYNCB (Fig. 2).
- Z80-SIO/2 sacrifices SYNCB and keeps TXCA, RXCB and DTRB (Fig. 3).

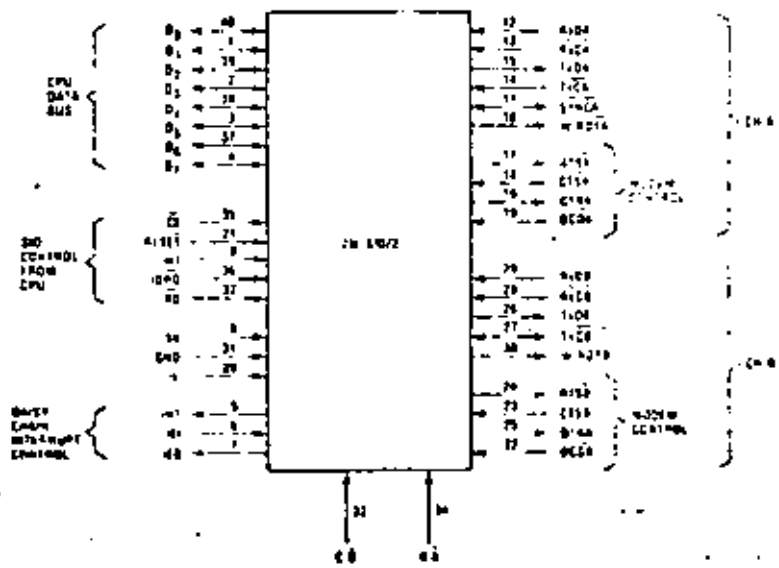

Figure 3. Z80 SIO/2 Pin Configuration

*These clocks may be directly driven by the Z80A TC (Counter-Timer Circuits) for fully programmable baud rate generation.

The device internal structure includes a Z80-CPU interface, internal control and interrupt logic, and two full-duplex channels. Associated with each channel are read and write registers, and discrete control and status logic that provides the interface to modems or other external devices.

The read and write register group includes five 8-bit control registers, two sync-character registers, and two status registers. The interrupt vector is written into an additional 5-bit register (Write Register 2) in Channel B that may be read through Read Register 2 in Channel B. The registers for both channels are designated in the text as follows:

- WR0-WR7 — Write Registers 0 through 7
- RR0-RR2 — Read Registers 0 through 2

The bit assignment and functional grouping of each register is configured to simplify and organize the programming process. Table 1 illustrates the functions assigned to each read or write register.

WR0	Register pointers, CRC initialize, initialization commands for the various modes, etc.
WR1	Transmit/Receive interrupt and data transfer mode definition
WR2	Interrupt vector (Channel B only)
WR3	Receive parameters and controls
WR4	Transmit/Receive miscellaneous parameters and modes
WR5	Transmit parameters and controls
WR6	Sync character or SDLC address field
WR7	Sync character or SDLC flag

(a) Write Register Functions

RR0	Transmit/Receive buffer status, interrupt status and external status
RR1	Special Receive Condition status
RR2	Modified interrupt vector (Channel B only)

(b) Read Register Functions

Table 1. Functional Assignments of Read and Write Registers

The logic for both channels provides formats, synchronization and validation for data transferred to and from the channel interface. The modem control inputs Clear to Send (CTS) and Data Carrier Detect (DCD) are monitored by the discrete control logic under program

control. All the modem control signals are general purpose in nature and can be used for functions other than modem control.

For automatic interrupt vectoring, the interrupt control logic determines which channel and which device within the channel has the highest priority. Priority is fixed with Channel A assigned a higher priority than Channel B; Receive, Transmit and External/Status interrupts are prioritized in that order within each channel.

Data Path

The transmit and receive data path for each channel is shown in Figure 4. The receiver has three 5-bit buffer registers in a FIFO arrangement (to provide a 3-byte delay) in addition to the 8-bit receive shift register. This arrangement creates additional time for the CPU to service an interrupt at the beginning of a block of high-speed data. The receive error FIFO stores parity and framing errors and other types of status information for each of the three bytes in the receive data FIFO.

Incoming data is routed through one of several paths depending on the mode and character length. In the Asynchronous mode, serial data is entered in the 5-bit buffer if it has a character length of seven or eight bits, or is entered in the 8-bit receive shift register if it has a length of five or six bits.

In the Synchronous mode, however, the data path is determined by the phase of the receive process currently in operation. A Synchronous Receive operation begins with the receiver in the Hunt phase, during which the receiver searches the incoming data stream for a bit pattern that matches the preprogrammed sync characters (or flags in the SDLC mode). If the device is programmed for Monosync Hunt, a match is made with a single sync character stored in WR7. In Bisync Hunt, a match is made with dual sync characters stored in WR6 and WR7.

In either case the incoming data passes through the receive sync register, and is compared against the programmed sync character in WR6 or WR7. In the Monosync mode, a match between the sync character programmed into WR7 and the character assembled in the receive sync register establishes synchronization.

In the Bisync mode, however, incoming data is shifted to the receive shift register while the next eight bits of the message are assembled in the receive sync register. The match between the assembled character in the receive sync registers with the programmed sync character in WR6 and WR7 establishes synchronization. Once synchronization is established, incoming data by-

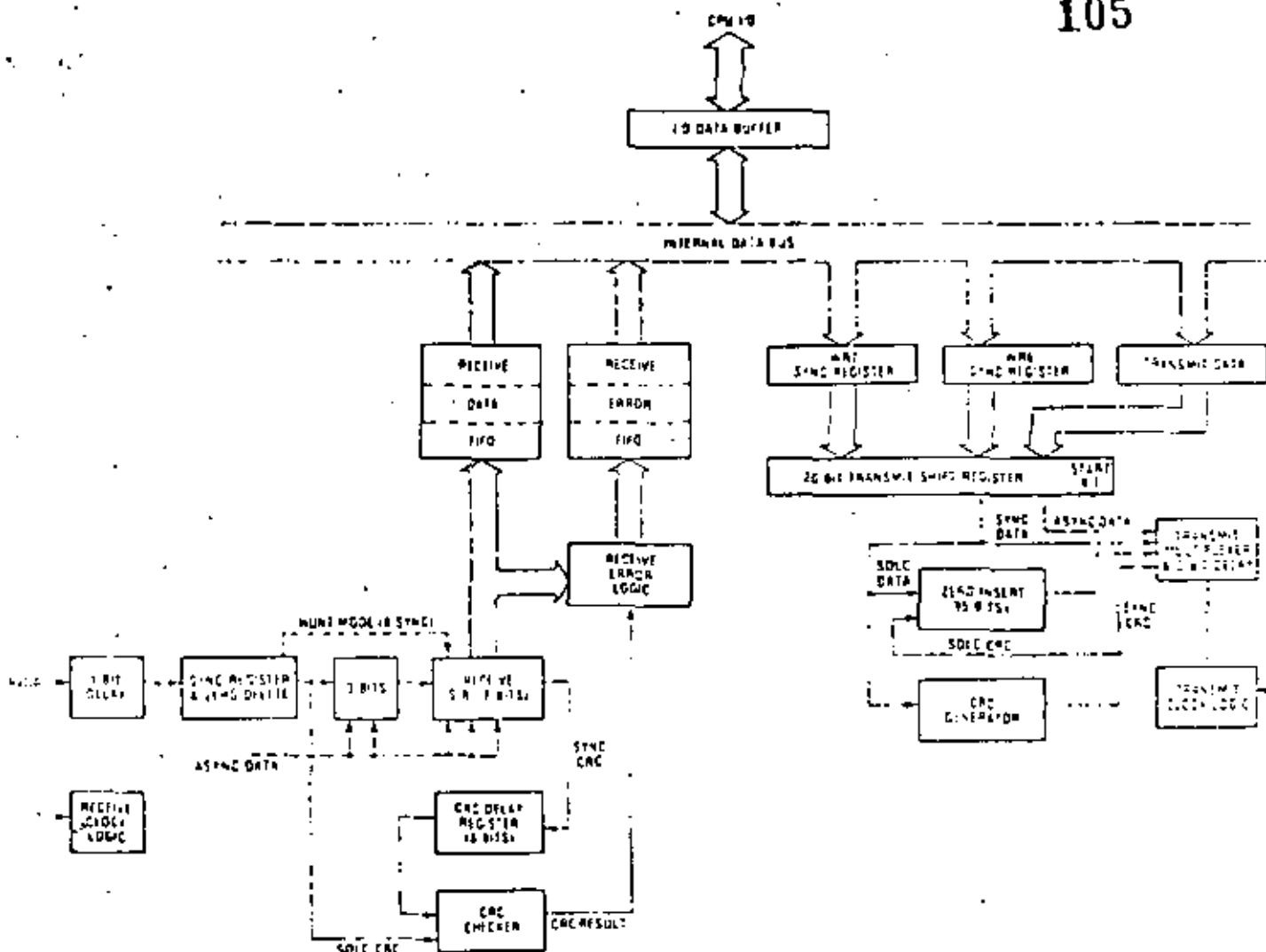

Figure 4. Transmit and Receive Data Path

passes the receive sync register and directly enters the 3-bit buffer.

In the SDLC mode, incoming data first passes through the receive sync register, which continuously monitors the receive data stream and performs zero deletion when indicated. Upon receiving five contiguous 1's, the sixth bit is inspected. If the sixth bit is a 0, it is deleted from the data stream. If the sixth bit is a 1, the seventh bit is inspected. If that bit is a 0, a Flag sequence has been received; if it is a 1, an Abort sequence has been received.

The reformatted data enters the 3-bit buffer and is transferred to the receive shift register. Note that the CRC receive operation also begins in the Hunt phase, during which the Z80-SIO tries to match the assembled character in the receive shift register with the flag pattern in WR7. Once the first flag character is recognized, all subsequent data is routed through the same path, regardless of character length.

Although the same CRC checker is used for both SDLC and synchronous data, the data path taken for each mode is different. In Bisync protocol, a byte-oriented operation requires that the CPU decide to include the data character in CRC. To allow the CPU ample time to make this decision, the Z80-SIO provides an 8-bit delay for synchronous data. In the SDLC mode, no delay is provided since the Z80-SIO contains logic that determines the bytes on which CRC is calculated.

The transmitter has an 8-bit transmit data register that is loaded from the internal data bus and a 20-bit transmit shift register that can be loaded from WR6, WR7 and the transmit data register. WR6 and WR7 contain sync characters in the Monosync or Bisync modes, or address field (one character long) and flag respectively in the SDLC mode. During Synchronous modes, information contained in WR6 and WR7 is loaded into the transmit shift register at the beginning of the message and, as a time filler, in the middle of the message if a Transmit Underrun condition occurs. In the SDLC mode, the flags are loaded into the transmit shift register at the beginning and end of message.

Asynchronous data in the transmit shift register is formatted with start and stop bits and is shifted out to the transmit multiplexer at the selected clock rate. Synchronous (Monosync or Bsync) data is shifted out to the transmit multiplexer and also to the CRC generator at the $\times 1$ clock rate.

SDLC HDLC data is shifted out through the zero insertion logic, which is disabled while the flags are being sent. For all other fields (address, control and frame check) a 0 is inserted following five contiguous 1's in the data stream. The CRC generator result for SDLC data is also routed through the zero insertion logic.

Interrupts. The Z80 SIO offers an elaborate interrupt scheme to provide fast interrupt response in real-time applications. As mentioned earlier, Channel B Registers $\times R1$ and $\times R2$ contain the interrupt vector that points to an interrupt service routine in the memory. To save operations in both channels and to eliminate the necessity of writing a status analysis routine, the Z80-SIO can modify the interrupt vector in $\times R2$ so it points directly to one of eight interrupt service routines. This is done under program control by setting a program bit ($\times R1, 0_7$) in Channel B called "Status Affects Vector." When this bit is set, the interrupt vector in $\times R2$ is modified according to the assigned priority of the various interrupting conditions. The table in the Write Register 1 description (Z80-SIO Programming section) shows the modification details.

Functional Description

The functional capabilities of the Z80-SIO can be described from two different points of view: as a data communications device, it transmits and receives serial data, and meets the requirements of various data communications protocols; as a Z80 family peripheral, it interacts with the Z80-CPU and other Z80 peripheral circuits, and shares their data, address and control busses, as well as being a part of the Z80 interrupt structure. As a peripheral to other microprocessors, the Z80-SIO offers valuable features such as non-vectorized interrupts, polling and simple handshake capabilities.

The first part of the following functional description describes the interaction between the CPU and Z80-SIO; the second part introduces its data communications capabilities.

I/O CAPABILITIES

The Z80-SIO offers the choice of Polling, Interrupt (vectorized or non-vectorized) and Block Transfer modes to transfer data, status and control information to and from the CPU. The Block Transfer mode can be implemented under CPU or DMA control.

Polling. The Polled mode avoids interrupts. Status registers $\times R0$ and $\times R1$ are updated at appropriate times for each function being performed (for example, CRC Error status valid at the end of the message). All the interrupt modes of the Z80-SIO must be disabled to operate the device in a polled environment.

While in its Polling sequence, the CPU examines the status contained in $\times R0$ for each channel; the $\times R0$ status bits serve as an acknowledge to the Poll inquiry. The two $\times R0$ status bits 0_0 and 0_1 indicate that a receive or transmit data transfer is needed. The status also indicates Error or other special status conditions (see Z80-SIO Programming[®]). The Special Receive Condition status contained in $\times R1$ does not have to be read in a Polling sequence because the status bits in $\times R1$ are accompanied by a Receive Character Available status in $\times R0$.

Transmit Interrupts, Receive Interrupts and External/Status Interrupts are the main sources of interrupts (Figure 5). Each interrupt source is enabled under program control with Channel A having a higher priority than Channel B, and with Receiver, Transmit and External/Status interrupts prioritized in that order within each channel. When the Transmit interrupt is enabled, the CPU is interrupted by the transmit buffer becoming empty. (This implies that the transmitter must have had a data character written into it so it can become empty.) When enabled, the receiver can interrupt the CPU in one of three ways:

- Interrupt on first receive character
- Interrupt on all receive characters
- Interrupt on a Special Receive condition

Interrupt On First Character is typically used with the Block Transfer mode. Interrupt On All Receive Characters has the option of modifying the interrupt vector in the event of a parity error. The Special Receive Condition interrupt can occur on a character or message basis (End Of Frame interrupt in SDLC, for example). The Special Receive condition can cause an interrupt only if the Interrupt On First Receive Character or Interrupt On All Receive Characters mode is selected. In Interrupt On First Receive Character, an interrupt can occur from Special Receive conditions (except Parity Error) after the first receive character interrupt (examples: Receive Overrun interrupt).

The main function of the External/Status interrupt is to monitor the signal transitions of the \overline{CTS} , \overline{DCD} and SYNC pins; however, an External/Status interrupt is also caused by a Transmit Underrun condition or by the detection of a Break (Asynchronous mode) or Abort (SDLC mode) sequence in the data stream. The interrupt caused by the Break/Abort sequence has a special feature that allows the Z80-SIO to interrupt when the Break/Abort sequence is detected or terminated. This feature facilitates the proper termination of the current message, correct initialization of the next message, and the accurate timing of the Break/Abort condition in external logic.

Write Register 1 description (Z80-SIO Programming section.)

DATA COMMUNICATIONS CAPABILITIES

In addition to the I/O capabilities previously discussed, the Z80-SIO provides two independent full-duplex channels as well as Asynchronous, Synchronous and SDLC (HDLC) operational modes. These modes facilitate the implementation of commonly used data communications protocols.

The specific features of these modes are described in the following sections. To preserve the independence and completeness of each section, some information common to all modes is repeated.

CPU DMA Block Transfer. The Z80-SIO provides a Block Transfer mode to accommodate CPU block transfer functions and DMA controllers (Z80 DMA or other designs). The Block Transfer mode uses the WAIT/READY output in conjunction with the Wait/Ready bits

Write Register 1. The WAIT/READY output can be defined under software control as a WAIT line in the CPU Block Transfer mode or as a READY line in the DMA Block Transfer mode.

To a DMA controller, the Z80-SIO READY output indicates that the Z80-SIO is ready to transfer data to or from memory. To the CPU, the WAIT output indicates that the Z80-SIO is not ready to transfer data, thereby requesting the CPU to extend the I/O cycle. The programming of bits 5, 6 and 7 of Write Register 1 and the logic states of the WAIT/READY line are defined in the

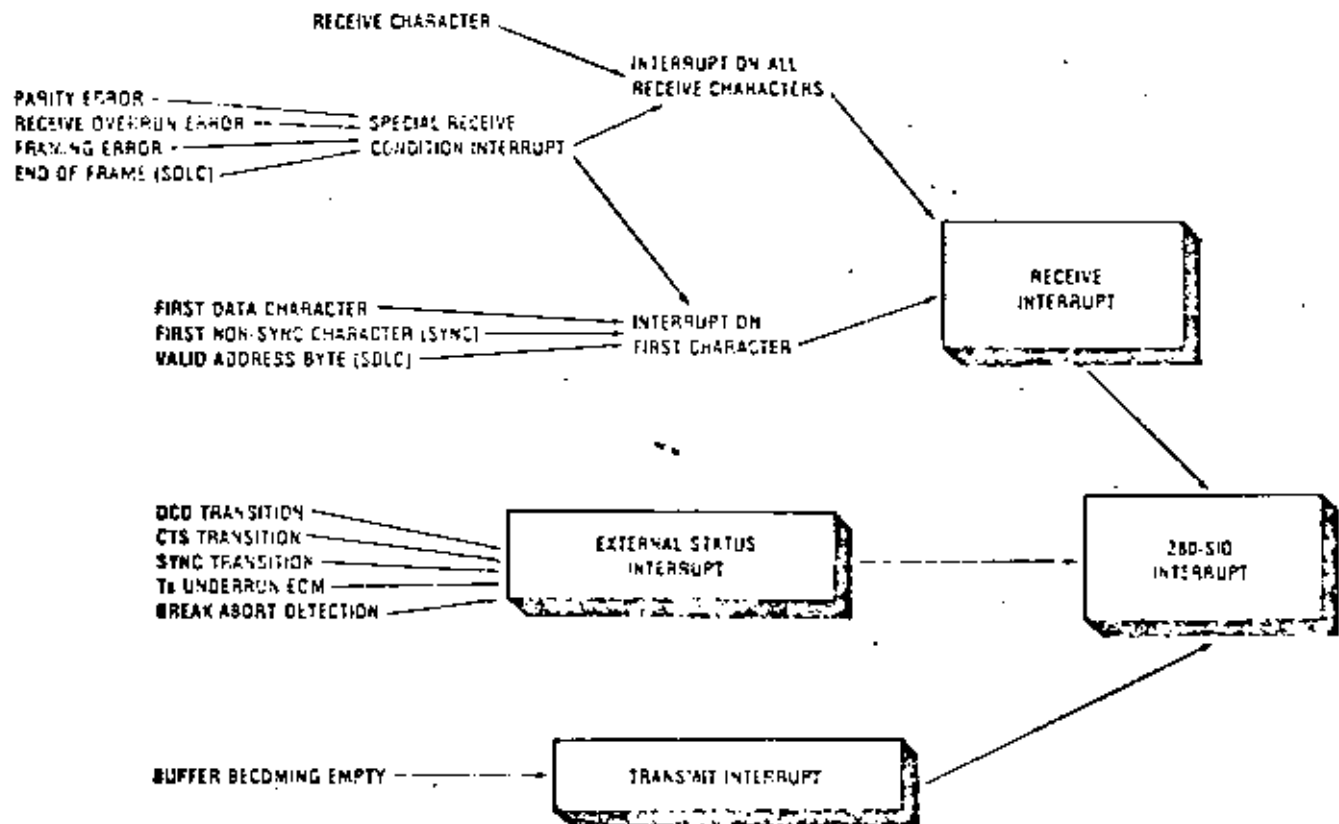

Figure 5. Interrupt Structure

to receive or transmit data in the Asynchronous mode, the Z80-SIO must be initialized with the following parameters: character length, clock rate, number of stop bits, even or odd parity, interrupt mode, and receiver or transmitter enable. The parameters are loaded into the appropriate write registers by the system program. WR4 parameters must be issued before WR1, WR3 and WR5 parameters or commands.

If the data is transmitted over a modem or RS232C interface, the REQUEST TO SEND (RTS) and DATA TERMINAL READY (DTX) outputs must be set along with the Transmit Enable bit. Transmission cannot begin until the Transmit Enable bit is set.

The Auto Enables feature allows the programmer to send the first data character of the message to the Z80-SIO without waiting for CTS. If the Auto Enables bit is set, the Z80-SIO will wait for the CTS pin to go Low before it begins data transmission. CTS, DCD and SYNC are general-purpose I/O lines that may be used for functions other than their labeled purposes. If CTS is used for another purpose, the Auto Enables Bit must be programmed to 0.

Figure 6 illustrates asynchronous message formats; Table 2 shows WR3, WR1 and WR5 with bits set to indicate the applicable modes, parameters and commands in asynchronous modes. WR3 (Channel B only) stores the interrupt vector; WR1 defines the interrupt modes and data transfer modes. WR6 and WR7 are not used in asynchronous modes. Table 3 shows the typical program steps that implement a full-duplex receive/transmit operation in either channel.

Asynchronous Transmit

The Transmit Data output (TxD) is held marking (High) when the transmitter has no data to send. Under program control, the Send Break (WR1, D2) command can be issued to hold TxD spacing (Low) until the command is cleared.

The Z80-SIO automatically adds the start bit, the programmed parity bit (odd, even or no parity) and the programmed number of stop bits to the data character to be transmitted. When the character length is six or seven bits, the unused bits are automatically ignored by the Z80-SIO. If the character length is five bits or less, refer to the table in the Write Register 5 description (Z80-SIO Programming section) for the data format.

Serial data is shifted from TxD at a rate equal to 1/16th, 1/32nd or 1/64th of the clock rate supplied to the Transmit Clock input (TxC). Serial data is shifted out on the falling edge of TxC.

If set, the External/Status Interrupt mode monitors the status of DCD, CTS and SYNC throughout the transmission of the message. If these inputs change for a period of time greater than the minimum specified pulse width, the interrupt is generated. In a transmit operation, this feature is used to monitor the modem control signal CTS.

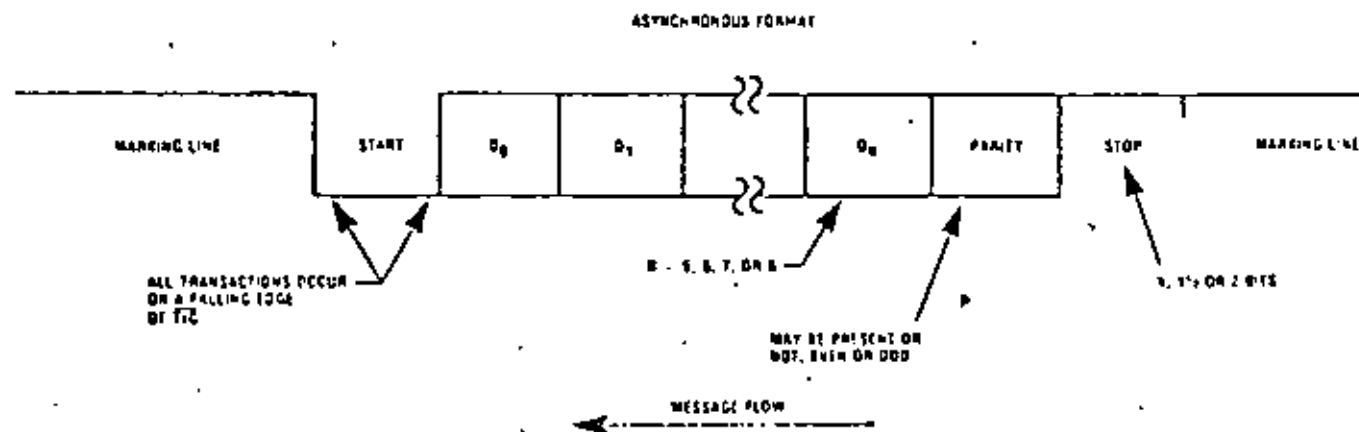

Figure 6. Asynchronous Message Format

An Asynchronous Receive operation begins when the Receive Enable bit is set. If the Auto Enables option is selected, \overline{RD} must be Low as well. A Low (spacing) condition on the Receive Data input (RD₀) indicates a start bit. If this Low persists for at least one-half of a bit time, the start bit is assumed to be valid and the data input is then sampled at mid-bit time until the entire character is assembled. This method of detecting a start bit improves error rejection when noise spikes exist on an otherwise marking line.

If the x1 clock mode is selected, bit synchronization must be accomplished externally. Receive data is sampled on the rising edge of RxC. The receiver inserts 1's when a character length of other than eight bits is used. If parity is enabled, the parity bit is not stripped from the assembled character for character lengths other than eight bits. For lengths other than eight bits, the receiver assembles a character length of the required number of data bits, plus a parity bit and 1's for any unused bits. For example, the receiver assembles a 5-bit character with the following format: 11 P D₄ D₃ D₂ D₁ D₀.

Since the receiver is buffered by three 8-bit registers in addition to the receive shift register, the CPU has enough time to service an interrupt and to accept the data character assembled by the Z30-SIO. The receiver also has three buffers that store error flags for each data character in the receive buffer. These error flags are latched at the same time as the data characters.

After a character is received, it is checked for the following error conditions:

- When parity is enabled, the Parity Error bit (PE, D₄) is set whenever the parity bit of the character does not match with the programmed parity. Once this bit is set, it remains set until the Error Reset Command (WR0) is given.
- The Framing Error bit (FE, D₃) is set if the character is assembled without any stop bits (that is, a Low level detected for a stop bit). Unlike the Parity Error bit, this bit is set (and not latched) only for the character on which it occurred. Detection of framing error adds an additional one-half of a bit time to the character time so the framing error is not interpreted as a new start bit.
- If the CPU fails to read a data character while more than three characters have been received, the Receive Overrun bit (RO, D₂) is set. When this occurs, the fourth character assembled replaces the third character in the receive buffers. With this arrangement, only the character that has been written over is flagged with the Receive Overrun Error bit. Like Parity Error, this bit can only be reset by the Error Reset command from the CPU. Both the Framing Error and Receive Overrun Error cause an interrupt with the interrupt vector indicating a Special Receive condition (if Status Affects Vector is selected).

Since the Parity Error and Receive Overrun Error flags are latched, the error status that is read reflects an error in the current word in the receive buffer plus any Parity or Overrun Errors received since the last Error Reset command. To keep correspondence between the state of the error buffers and the contents of the receive data buffers, the error status register must be read before the data. This is easily accomplished if vectored

	BIT 7	BIT 6	BIT 5	BIT 4	BIT 3	BIT 2	BIT 1	BIT 0
WR3	00 = R _x 5 BITS CHAR 10 = R _x 6 BITS CHAR 01 = R _x 7 BITS CHAR 11 = R _x 8 BITS CHAR		AUTO ENABLES	0	0	0	0	R _e ENABLE
WR4	00 = x1 CLOCK MODE 01 = x16 CLOCK MODE 10 = x32 CLOCK MODE 11 = x64 CLOCK MODE	0	0		00 = NOT USED 01 = 1 STOP BIT CHAR 10 = 1 1/2 STOP BITS CHAR 11 = 2 STOP BITS CHAR		EVEN ODD PARITY	PARITY ENABLE
WR5	OTR	00 = T _x 5 BITS (OR LESS) CHAR 10 = T _x 6 BITS CHAR 01 = T _x 7 BITS CHAR 11 = T _x 8 BITS CHAR		SEND BREAK	T _x ENABLE	0	RTS	0

Table 2. Contents of Write Registers 3, 4 and 5 in Asynchronous Modes

FUNCTION	TYPICAL PROGRAM STEPS	COMMENTS
INITIALIZE	REGISTER INFORMATION LOADED	
	WR0 CHANNEL RESET	Reset SIO
	WR0 POINTER 2	
	WR2 INTERRUPT VECTOR	Channel B only
	WR0 POINTER 4, RESET EXTERNAL STATUS INTERRUPT	
	WR4 ASYNCHRONOUS MODE, PARITY INFORMATION, STOP BITS INFORMATION, CLOCK RATE INFORMATION	Issue parameters
	WR0 POINTER 3	
	WR3 RECEIVE ENABLE, AUTO ENABLES, RECEIVE CHARACTER LENGTH	
	WR0 POINTER 5	
	WR5 REQUEST TO SEND, TRANSMIT ENABLE, TRANSMIT CHARACTER LENGTH, DATA TERMINAL READY	Receive and Transmit both fully initialized. Auto Enables will enable transmitter if CTS is active and Receiver DCD is active.
WR6 POINTER 1, RESET EXTERNAL STATUS INTERRUPT		
WR7 TRANSMIT INTERRUPT ENABLE, STATUS AFFECTS VECTOR INTERRUPT ON ALL RECEIVE CHARACTERS, DISABLE WAIT READY FUNCTION, EXTERNAL INTERRUPT ENABLE	Transmit/Receive Interrupt mode selected. External Interrupts are active. Status of the CTS, DCD and DTR lines and detects the Break signal. Status Affects Vector in Channel B only.	
TRANSFER FIRST DATA BYTE TO SIO	This data byte must be transmitted. Transmit interrupts will occur.	
IDLE MODE	EXECUTE HALT INSTRUCTION OR SOME OTHER PROGRAM	Program is waiting for an interrupt from the SIO.
DATA TRANSFER AND ERROR MONITORING	280 INTERRUPT ACKNOWLEDGE CYCLE TRANSFERS R02 TO CPU	
	IF A CHARACTER IS RECEIVED <ul style="list-style-type: none"> TRANSFER DATA CHARACTER TO CPU UPDATE POINTERS AND PARAMETERS RETURN FROM INTERRUPT 	When the interrupt occurs, the interrupt vector is modified by: 1. Receive Character Available; 2. Transmitter Buffer Empty; 3. External Status Change; and 4. Special Receive condition.
	IF TRANSMITTER BUFFER IS EMPTY <ul style="list-style-type: none"> TRANSFER DATA CHARACTER TO SIO UPDATE POINTERS AND PARAMETERS RETURN FROM INTERRUPT 	Program control is transferred to one of the eight interrupt service routines.
	IF EXTERNAL STATUS CHANGES <ul style="list-style-type: none"> TRANSFER R02 TO CPU PERFORM ERROR ROUTINES (INCLUDE BREAK DETECTION) RETURN FROM INTERRUPT 	If used with processors other than the modified interrupt vector, R02 will be returned to the CPU in the interrupt acknowledge sequence.
	IF SPECIAL RECEIVE CONDITION OCCURS <ul style="list-style-type: none"> TRANSFER R01 TO CPU DO SPECIAL ERROR (E.G. FRAMING ERROR) ROUTINE RETURN FROM INTERRUPT 	
TERMINATION	REDEFINE RECEIVE/TRANSMIT INTERRUPT MODES	When transmit or receive data transfer is complete.
	DISABLE TRANSMIT/RECEIVE MODES	
	UPDATE MODEM CONTROL OUTPUTS (E.G. RTS OFF)	In Transmit, the All Send status indicates transmission is complete.

Table 3. Asynchronous Mode

interrupts are used, because a special interrupt vector is generated for these conditions.

While the External/Status interrupt is enabled, break detection causes an interrupt and the Break Detected status bit (RR0, D₂) is set. The Break Detected interrupt should be handled by issuing the Reset External/Status Interrupt command to the Z80-SIO in response to the first Break Detected interrupt that has a Break status of 1 (RR0, D₂). The Z80-SIO monitors the Receive Data input and waits for the Break sequence to terminate, at which point the Z80-SIO interrupts the CPU with the Break status set to 0. The CPU must again issue the Reset External/Status Interrupt command in its interrupt service routine to reinitialize the break detection logic.

The External/Status interrupt also monitors the status of DCD. If the DCD pin becomes inactive for a period greater than the minimum specified pulse width, an interrupt is generated with the DCD status bit (RR0, D₃) set to 1. Note that the DCD input is inverted in the RR0 status register.

If the status is read after the data, the error data for the next word is also included if it has been stacked in the buffer. If operations are performed rapidly enough so the next character is not yet received, the status regis-

ter remains valid. An exception occurs when the Interrupt On First Character Only mode is selected. A special interrupt in this mode holds the error data and the character itself (even if read from the buffer) until the First Reset command is issued. This prevents further data from becoming available in the receiver until the Reset command is issued, and allows CPU intervention on the character with the error even if DMA or block transfer techniques are being used.

If Interrupt On Every Character is selected, the interrupt vector is different if there is an error status in RR0. If a Receiver Overrun occurs, the most recent character received is loaded into the buffer; the character preceding it is lost. When the character that has been written over the other characters is read, the Receive Overrun bit is set and the Special Receive Condition vector is returned if Status Affects Vector is enabled.

In a polled environment, the Receive Character Available bit (RR0, D₀) must be monitored so the Z80-CPU can know when to read a character. This bit automatically resets when the receive buffers are read. To prevent overwriting data in polled operations, the transmit buffer status must be checked before writing into the transmitter. The Transmit Buffer Empty bit is set to 1 whenever the transmit buffer is empty.

Before describing synchronous transmission and reception, the three types of character synchronization—Monosync, Bisync and External Sync—require some explanation. These modes use the $\times 1$ clock for both Transmit and Receive operations. Data is sampled on the rising edge of the Receive Clock input (\overline{RxC}). Transmitter data transitions occur on the falling edge of the Transmit Clock input (\overline{TxC}).

The differences between Monosync, Bisync and External Sync are in the manner in which initial character synchronization is achieved. The mode of operation must be selected before sync characters are loaded, because the registers are used differently in the various modes. Figure 7 shows the formats for all three of these synchronous modes.

Monosync. In a Receive operation, matching a single sync character (8-bit sync mode) with the programmed sync character stored in WR7 implies character synchronization and enables data transfer.

Bisync. Matching two contiguous sync characters (16-bit sync mode) with the programmed sync characters stored in WR4 and WR7 implies character synchronization. In both the Monosync and Bisync modes, SYNC is used as an output, and is active for the part of the receive clock that detects the sync character.

External Sync. In this mode, character synchronization is established externally: SYNC is an input that indicates external character synchronization has been achieved. After the sync pattern is detected, the external logic must wait for two full Receive Clock cycles to activate the SYNC input. The SYNC input must be held Low until character synchronization is lost. Character assembly begins on the rising edge of \overline{RxC} that precedes the falling edge of SYNC.

In all cases after a reset, the receiver is in the Hunt phase, during which the Z80-SIO looks for character synchronization. The hunt can begin only when the receiver is enabled, and data transfer can begin only when character synchronization has been achieved. If character synchronization is lost, the Hunt phase can be re-entered by writing a control word with the Enter Hunt Phase bit set (WR3, D₃). In the Transmit mode, the transmitter always sends the programmed number of sync bits (8 or 16). In the Monosync mode, the transmitter transmits from WR6; the receiver compares against WR7.

In the Monosync, Bisync and External Sync modes, assembly of received data continues until the Z80-SIO is reset, or until the receiver is disabled (by command or by \overline{DCD} in the Auto Enables mode), or until the Enter Hunt Phase bit.

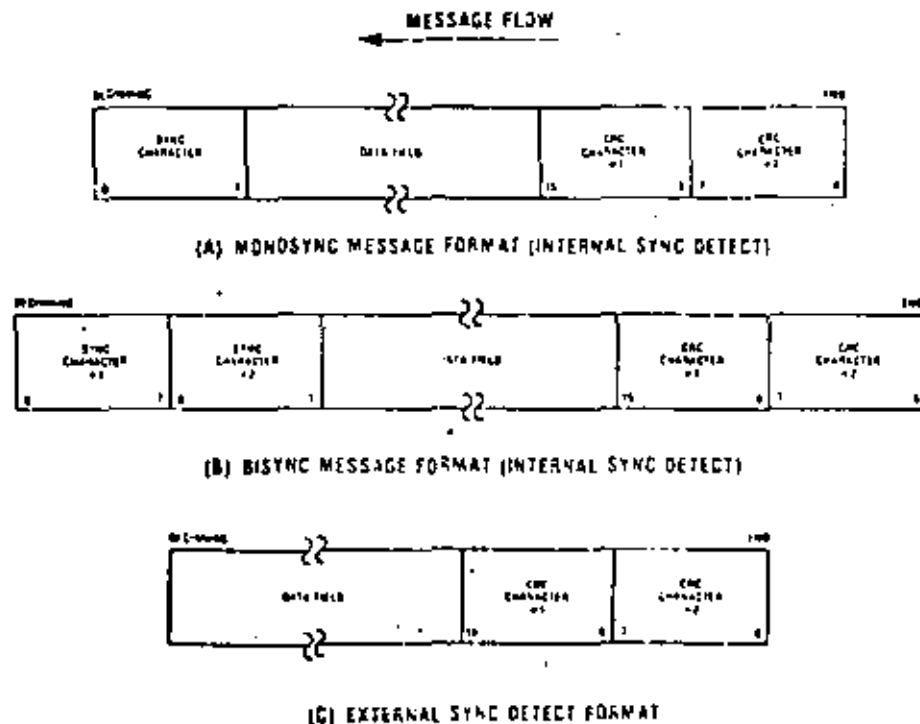

Figure 7. Synchronous Formats

After initial synchronization has been achieved, the operation of the Monosync, Bisync and External Sync modes is quite similar. Any differences are specified in the following text.

Table 4 shows how WR3, WR4 and WR5 are used in synchronous receive and transmit operations. WR0 points to other registers and issues various commands, WR1 defines the interrupt modes, WR2 stores the interrupt vector, and WR6 and WR7 store sync characters. Table 5 illustrates the typical program steps that implement a half-duplex Bisync transmit operation.

Synchronous Transmit

INITIALIZATION

The system program must initialize the transmitter with the following parameters: odd or even parity, $\times 1$ clock mode, 8- or 16-bit sync character(s), CRC polynomial, Transmitter Enables, Request To Send, Data Terminal Ready, interrupt modes and transmit character length. WR4 parameters must be issued before WR1, WR3, WR5, WR6 and WR7 parameters or commands.

One of two polynomials—CRC-16 ($X^{16} + X^{15} + X^2 + 1$) or SDLC ($X^{16} + X^{12} + X^5 + 1$)—may be used with synchronous modes. In either case (SDLC mode not selected), the CRC generator and checker are reset to all

In the transmit initialization process, the CRC generator is initialized by setting the Reset Transmit CRC Generator command bits (WR0). Both the transmitter and the receiver use the same polynomial.

Transmit Interrupt Enable or Wait/Ready Enable

can be selected to transfer the data. The External/Status interrupt mode is used to monitor the status of the CLEAR TO SEND input as well as the Transmit Under-run/EDM latch. Optionally, the Auto Enables feature can be used to enable the transmitter when CTS is active. The first data transfer to the Z80-SIO can begin when the External/Status interrupt occurs (CTS status bit set) or immediately following the Transmit Enable command (if the Auto Enables modes is set).

Transmit data is held marking after reset or if the transmitter is not enabled. Break may be programmed to generate a spacing line that begins as soon as the Send Break bit is set. With the transmitter fully initialized and enabled, the default condition is continuous transmission of the 8- or 16-bit sync character.

DATA TRANSFER AND STATUS MONITORING

In this phase, there are several combinations of interrupts and Wait/Ready.

Data Transfer Using Interrupts. If the Transmit Interrupt Enable bit (WR1, D₁) is set, an interrupt is generated each time the transmit buffer becomes empty. The interrupt can be satisfied either by writing another character into the transmitter or by resetting the Transmitter Interrupt Pending latch with a Reset Transmitter Pending command (WR0, CMD₅). If the interrupt is satisfied with this command and nothing more is written into the transmitter, there can be no further Transmit Buffer Empty interrupts, because it is the process of the buffer becoming empty that causes the interrupts and the buffer cannot become empty when it is already empty. This situation does cause a Transmit Under-run condition, which is explained in the "Bisync Transmit Under-run" section.

	BIT 7	BIT 6	BIT 5	BIT 4	BIT 3	BIT 2	BIT 1	BIT 0
WR3	00 = R _x 5 BITS CHAR 10 = R _x 6 BITS CHAR 01 = R _x 7 BITS CHAR 11 = R _x 8 BITS CHAR		AUTO ENABLES	ENTER HUNT MODE	R _x CRC ENABLE	0	SYNC CHAR LOAD INHIBIT	R _x ENABLE
WR4	0	0	00 = 8-BIT SYNC CHAR 01 = 16-BIT SYNC CHAR 10 = SDLC MODE 11 = EXT SYNC MODE		0 SELECTS SYNC MODES	0	EVEN ODD PARITY	PARITY ENABLE
WR5	DTR	00 = T _x 5 BITS (CR LESS) CHAR 10 = T _x 6 BITS CHAR 01 = T _x 7 BITS CHAR 11 = T _x 8 BITS CHAR		SEND BREAK	T _x ENABLE	1 SELECTS CRC-16	RTS	T _x CRC ENABLE

Table 4. Contents of Write Registers 3, 4 and 5 in Synchronous Modes

Data Transfer Using WAIT READY. To the CPU, the activation of **WAIT** indicates that the Z80-SIO is not ready to accept data and that the CPU must extend the output cycle. To a DMA controller, **READY** indicates that the transmit buffer is empty and that the Z80-SIO is ready to accept the next data character. If the data character is not loaded into the Z80-SIO by the time the transmit shift register is empty, the Z80-SIO enters the **Transmit Underrun** condition.

Bisync Transmit Underrun. In Bisync protocol, filler characters are inserted to maintain synchronization when the transmitter has no data to send (**Transmit Underrun** condition). The Z80-SIO has two programmable options for solving this situation: it can insert sync characters, or it can send the CRC characters generated so far, followed by sync characters.

These options are under the control of the **Reset Transmit Underrun/EOM** command in **WR0**. Following a chip or channel reset, the **Transmit Underrun/EOM** status bit (**WR0, D6**) is in a set condition and allows the insertion of sync characters when there is no data to send. CRC is not calculated on the automatically inserted sync characters. When the CPU detects the end of message, a **Reset Transmit Underrun/EOM** command can be issued. This allows CRC to be sent when the transmitter has no data. In this case, the Z80-SIO sends CRC, followed by sync characters, to terminate the message.

There is no restriction as to when in the message the **Transmit Underrun/EOM** bit can be reset. If **Reset** is issued after the first data character has been loaded the 16-bit CRC is sent and followed by sync characters the first time the transmitter has no data to send. Because of the **Transmit Underrun** condition, an **External/Status** interrupt is generated whenever the **Transmit Underrun/EOM** bit becomes set.

In the case of sync insertion, an interrupt is generated only after the first automatically inserted sync character has been loaded. The status indicates the **Transmit Underrun/EOM** bit and the **Transmit Buffer Empty** bit are set.

In the case of CRC insertion, the **Transmit Underrun/EOM** bit is set and the **Transmit Buffer Empty** bit is reset while CRC is being sent. When CRC has been completely sent, the **Transmit Buffer Empty** status bit is set and an interrupt is generated to indicate to the CPU that another message can begin (this interrupt occurs because CRC has been sent and sync has been loaded). If no more messages are to be sent, the program can terminate transmission by resetting **RTS**, and disabling the transmitter (**WR5, D3**).

Pad characters may be sent by setting the Z80-SIO to 8 bits/transmit character and writing **FF** to the transmitter while CRC is being sent. Alternatively, the sync characters can be redefined as pad characters during this time. The following example is included to clarify this point.

The Z80-SIO interrupts with the **Transmit Buffer Empty** bit set.

The CPU recognizes that the last character (etc.) of the message has already been sent to the Z80-SIO by examining the internal program status.

To force the Z80-SIO to send CRC, the CPU issues the **Reset Transmit Underrun/EOM Latch** command (**WR1**) and satisfies the interrupt with the **Reset Transmit Interrupt Pending** command. (This command prevents the Z80-SIO from requesting more data.) Because of the transmit underrun caused by this command, the Z80-SIO starts sending CRC. The Z80-SIO also causes an **External/Status** interrupt with the **Transmit Underrun/EOM Latch** set.

The CPU satisfies this interrupt by loading pad characters into the transmit buffer and issuing the **Reset External Status Interrupt** command.

With this sequence, CRC is followed by a pad character instead of a sync character. Note that the Z80-SIO will interrupt with a **Transmit Buffer Empty** interrupt when CRC is completely sent and that the pad character is loaded into the transmit shift register.

From this point on the CPU can send more pad characters or sync characters.

Bisync CRC Generation. Setting the **Transmit CRC enable** bit (**WR5, D6**) initiates CRC accumulation when the program sends the first data character to the Z80-SIO. Although the Z80-SIO automatically transmits up to two sync characters (16-bit sync), it is wise to send a few more sync characters ahead of the message (before enabling **Transmit CRC**) to ensure synchronization at the receiving end.

The **transmit CRC Enable** bit can be changed on the fly any time in the message to include or exclude a particular data character from CRC accumulation. The **Transmit CRC Enable** bit should be in the desired state when the data character is loaded from the transmit data buffer into the transmit shift register. To ensure this bit is in the proper state, the **Transmit CRC Enable** bit must be issued before sending the data character to the Z80-SIO.

Transmit Transparent Mode. Transparent mode (Bisync protocol) operation is made possible by the ability to change **Transmit CRC Enable** on the fly and by the additional capability of inserting 16-bit sync characters. Exclusion of DLE characters from CRC calculation can be achieved by disabling CRC calculation immediately preceding the DLE character transfer to the Z80-SIO.

In the case of a **Transmit Underrun** condition in the **Transparent** mode, a pair of **DLE SYN** characters are sent. The Z80-SIO can be programmed to send the **DLE SYN** sequence by loading a **DLE** character into **WR6** and a sync character into **WR7**.

Transmit Termination. The Z80-SIO is equipped with a special termination feature that maintains data integrity and validity. If the transmitter is disabled while a data or sync character is being sent, that character is sent as usual, but is followed by a marking line rather than CRC or sync characters. When the transmitter is disabled, a

FUNCTION	TYPICAL PROGRAM STEPS	COMMENTS
INITIALIZE	REGISTER INFORMATION LOADED	
	WR0 CHANNEL RESET, RESET TRANSMIT CRC GENERATOR	Reset SIO, initialize CRC generator.
	WR0 POINTER 2	
	WR2 INTERRUPT VECTOR	Channel B only
	WR0 POINTER 3	
	WR3 AUTO ENABLES	Transmission begins only after CTS is detected.
	WR0 POINTER 4	
	WR4 PARITY INFORMATION, SYNC MODES INFORMATION, *1 CLOCK MODE	Issue transmit parameters
	WR0 POINTER 6	
	WR5 SYNC CHARACTER 1	
	WR0 POINTER 7, RESET EXTERNAL STATUS INTERRUPTS	
	WR7 SYNC CHARACTER 2	
	WR0 POINTER 1, RESET EXTERNAL STATUS INTERRUPTS	
	WR1 STATUS AFFECTS VECTOR, EXTERNAL INTERRUPT ENABLE, TRANSMIT INTERRUPT ENABLE OR WAIT READY MODE ENABLE	External interrupt mode monitors the status of CTS and DCD inputs as well as the status of Tx Underrun EDM and Transmit Interrupt Enable outputs. When the Transmit buffer becomes empty, the Wait Ready mode can be used to transfer data using DMA or CPU Block Transfer.
WR0 POINTER 5	Status Affects Vector (Channel B only)	
WR5 REQUEST TO SEND, TRANSMIT ENABLE, B1 SYNC CRC, TRANSMIT CHARACTER LENGTH	Transmit CRC Enable should be set when first non-sync data is sent to SIO-SIO	
FIRST SYNC BYTE TO SIO	Need several sync characters at the beginning of message. Transmitter is initialized.	
IDLE MODE	EXECUTE HALT INSTRUCTION OR SOME OTHER PROGRAM	Waiting for interrupt or Wait Ready output to transfer data.
DATA TRANSFER AND STATUS MONITORING	<p>WHEN INTERRUPT (WAIT READY) OCCURS</p> <ul style="list-style-type: none"> • INCLUDE/EXCLUDE DATA BYTE FROM CRC ACCUMULATION (IN SIO). • TRANSFER DATA BYTE FROM CPU (OR MEMORY) TO SIO • DETECT AND SET APPROPRIATE FLAGS FOR CONTROL CHARACTERS (IN CPU) • RESET Tx UNDERRUN EDM LATCH (WR0) IF LAST CHARACTER OF MESSAGE IS DETECTED • UPDATE POINTERS AND PARAMETERS (CPU) • RETURN FROM INTERRUPT. 	Interrupt occurs (Wait Ready becomes active) when first data byte is being sent. Wait mode allows CPU block transfer from memory to SIO. Ready mode allows DMA block transfer from memory to SIO. The DMA chip can be programmed to detect special control characters (by examining only the bits that specify ASCII or EBCDIC control characters), and interrupt CPU.
	<p>IF ERROR CONDITION OR STATUS CHANGE OCCURS.</p> <ul style="list-style-type: none"> • TRANSFER RR0 TO CPU • EXECUTE ERROR ROUTINE. • RETURN FROM INTERRUPT. 	Tx Underrun EDM indicates either transmit underrun (sync character being sent) or end of message (CRC is being sent).
TERMINATION	REDEFINE INTERRUPT MODES.	
	UPDATE MODEM CONTROL OUTPUTS (E.G., TURN OFF RTS)	Program should gracefully terminate message.
	DISABLE TRANSMIT MODE	

Table 5. Bisync Transmit Mode

character in the buffer remains in the buffer. If the transmitter is disabled while CRC is being sent, the 16-bit transmission is completed, but sync is sent instead of CRC.

A programmed break is effective as soon as it is written into the control register; characters in the transmit buffer and shift register are lost.

In all modes, characters are sent with the least significant bits first. This requires right-hand justification of transmitted data if the word length is less than eight bits. If the word length is five bits or less, the special technique described in the Write Register 5 discussion (Z80-SIO Programming section) must be used for the data format. The states of any unused bits in a data character are irrelevant, except when in the Five Bits Or Less mode.

If the External/Status Interrupt Enable bit is set, transmitter conditions such as "starting to send CRC characters," "starting to send sync characters," and CTS changing state cause interrupts that have a unique vector if Status Affects Vector is set. This interrupt mode may be used during block transfers.

All interrupts may be disabled for operation in a Polled mode, or to avoid interrupts at inappropriate times during the execution of a program.

Synchronous Receive

INITIALIZATION

The system program initiates the Synchronous Receive operation with the following parameters: odd or even parity, 8- or 16-bit sync characters, $\times 1$ clock mode, CRC polynomial, receive character length, etc. Sync characters must be loaded into registers WR6 and WR7. The receivers can be enabled only after all receive parameters are set. WR4 parameters must be issued before WR1, WR3, WR5, WR6 and WR7 parameters or commands.

After this is done, the receiver is in the Hunt phase. It remains in this phase until character synchronization is achieved. Note that, under program control, all the leading sync characters of the message can be inhibited from loading the receive buffers by setting the Sync Character Load Inhibit bit in WR3.

DATA TRANSFER AND STATUS MONITORING

When character synchronization is achieved, the assembled characters are transferred to the receive data FIFO. The following four interrupt modes are available to transfer the data and its associated status to the CPU.

No Interrupts Enabled. This mode is used for a purely polled operation or for off-line conditions.

Interrupt On First Character Only. This mode is normally used to start a polling loop or a Block Transfer instruction using WAIT READY to synchronize the CPU or the DMA device to the incoming data rate. In this mode the Z80-SIO interrupts on the first character and then, after interrupts only if Special Receive conditions are detected. The mode is reinitialized with the Enable Interrupt On Next Receive Character command to allow the next character received to generate an interrupt. Parity errors do not cause interrupts in this mode, but End Of Frame (SDLC mode) and Receive Overrun do.

If External/Status interrupts are enabled, they may interrupt any time DCD changes state.

Interrupt On Every Character. Whenever a character enters the receive buffer, an interrupt is generated. Error and Special Receive conditions generate a special vector if Status Affects Vector is selected. Optionally, a Parity Error may be directed not to generate the special interrupt vector.

Special Receive Condition Interrupts. The Special Receive Condition interrupt can occur only if either the Receive Interrupt On First Character Only or Interrupt On Every Receive Character modes is also set. The Special Receive Condition interrupt is caused by the Receive Overrun error condition. Since the Receive Overrun and Parity error status bits are latched, the error status—when read—reflects an error in the current word in the receive buffer in addition to any Parity or Overrun errors received since the last Error Reset command. These status bits can only be reset by the Error reset command.

CRC Error Checking and Termination. A CRC error check on the receive message can be performed on a per character basis under program control. The Receive CRC Enable bit (WR3, D3) must be set/reset by the program before the next character is transferred from the receive shift register into the receive buffer register. This ensures proper inclusion or exclusion of data characters in the CRC check.

To allow the CPU ample time to enable or disable the CRC check on a particular character, the Z80-SIO recalculates CRC eight bit times after the character has been transferred to the receive buffer. If CRC is enabled before the next character is transferred, CRC is calculated on the transferred character. If CRC is disabled before the time of the next transfer, calculation proceeds on the word in progress, but the word just transferred to the buffer is not included. When these requirements are satisfied, the 3-byte receive data buffer is, in effect, unusable in Bisync operation. CRC may be enabled and disabled as many times as necessary for a given calculation.

In the Monosync, Bisync and External Sync modes, the CRC/Framing Error bit (RR1, D6) contains the comparison result of the CRC checker 16 bit times (eight bits delay and eight shifts for CRC) after the character has been transferred from the receive shift register to the buffer. The result should be zero, indicating an error-

free transmission. (Note that the result is valid only at the end of CRC calculation. If the result is examined before this time, it usually indicates an error.) The comparison is made with each transfer and is valid only as long as the character remains in the receive FIFO.

Following is an example of the CRC checking operation when four characters (A, B, C and D) are received in that order.

Character A loaded into buffer
Character B loaded into buffer

If CRC is disabled before C is in the buffer, CRC is not calculated on B.

Character C loaded into buffer

After C is loaded, the CRC/Framing Error bit shows the result of the comparison through character A.

After D is in the buffer, the CRC Error bit shows the result of the comparison through character B whether or not B was included in the CRC calculations.

Due to the serial nature of CRC calculation, the Receive Clock (\overline{RxC}) must cycle 16 times (8-bit delay plus 8-bit CRC shift) after the second CRC character has been loaded into the receive buffer, or 20 times (the previous 16 plus 3-bit buffer delay and 1-bit input delay) after the last bit is at the RxD input, before CRC calculation is complete. A faster external clock can be gated into the Receive Clock input to supply the required 16 cycles. The Transmit and Receive Data Path diagram (Figure 4) illustrates the various points of delay in the CRC path.

The typical program steps that implement a half-duplex Bisync Receive mode are illustrated in Table 6. The complete set of command and status bit definitions are explained under "280-SIO Programming."

FUNCTION	TYPICAL PROGRAM STEPS	COMMENTS
	REGISTER INFORMATION LOADED	
	WR0 CHANNEL RESET, RESET RECEIVE CRC CHECKER	Reset SIO. Initialize Receive CRC checker
	WR0 POINTER 2	
	WR2 INTERRUPT VECTOR	Channel B only
	WR0 POINTER 4	
	WR4 PARITY INFORMATION, SYNC MODES INFORMATION, x1 CLOCK MODE	Issue receive parameters.
	WR0 POINTER 5, RESET EXTERNAL STATUS INTERRUPT	
	WR5 BISYNC CRC-16, DATA TERMINAL READY	
	WR0 POINTER 3	
INITIALIZE	WR3 SYNC CHARACTER LOAD INHIBIT, RECEIVE CRC ENABLE, ENTER HUNT MODE, AUTO ENABLES, RECEIVE CHARACTER LENGTH	Sync character load inhibit strips all the leading sync characters at the beginning of the message. Auto Enables enables the receiver to accept data only after the \overline{OCD} input is active.
	WR0 POINTER 6	
	WR6 SYNC CHARACTER 1	
	WR0 POINTER 7	
	WR7 SYNC CHARACTER 2	
	WR0 POINTER 1, RESET EXTERNAL STATUS INTERRUPT	
	WR1 STATUS AFFECTS VECTOR, EXTERNAL INTERRUPT ENABLE, RECEIVE INTERRUPT ON FIRST CHARACTER ONLY	In this interrupt mode, only the first non-sync data character is transferred to the CPU. All subsequent data is transferred on a DMA basis, however Special Receive Condition interrupts will interrupt the CPU. Status Affects Vector used in Channel B only.

Table 6. Bisync Receive Mode

FUNCTION	TYPICAL PROGRAM STEPS	COMMENTS
INITIALIZE (CONTINUED)	<p>WR0 POINTER3, ENABLE INTERRUPT ON NEXT RECEIVE CHARACTER</p> <p>WR0 RECEIVE ENABLE, SYNC CHARACTER LOAD INHIBIT, ENTER HUNT MODE, AUTO ENABLE, RECEIVE WORD LENGTH</p>	<p>Resetting this interrupt mode provides simple program loopback entry for next transaction.</p> <p>WR0 is reissued to enable receiver. Receive CRC Enable must be set after receiving SOH or STX character.</p>
IDLE MODE	EXECUTE HALT INSTRUCTION OR SOME OTHER PROGRAM	Receive mode is fully initialized and the system is waiting for interrupt on this character.
DATA TRANSFER AND STATUS MONITORING	<p>WHEN INTERRUPT ON FIRST CHARACTER OCCURS, THE CPU DOES THE FOLLOWING</p> <ul style="list-style-type: none"> • TRANSFERS DATA BYTE TO CPU • DETECTS AND SETS APPROPRIATE FLAGS FOR CONTROL CHARACTERS (IN CPU) • INCLUDES EXCLUDES DATA BYTE IN CRC CHECKER • UPDATES POINTERS AND OTHER PARAMETERS • ENABLES WAIT READY FOR DMA OPERATION • ENABLES DMA CONTROLLER • RETURNS FROM INTERRUPT <p>WHEN WAIT READY BECOMES ACTIVE, THE DMA CONTROLLER DOES THE FOLLOWING</p> <ul style="list-style-type: none"> • TRANSFERS DATA BYTE TO MEMORY • INTERRUPTS CPU IF A SPECIAL CHARACTER IS CAPTURED BY THE DMA CONTROLLER • INTERRUPTS THE CPU IF THE LAST CHARACTER OF THE MESSAGE IS DETECTED <p>FOR MESSAGE TERMINATION THE CPU DOES THE FOLLOWING</p> <ul style="list-style-type: none"> • TRANSFERS RRV TO THE CPU • SETS ACK, NAK REPLY FLAG BASED ON CRC RESULT • UPDATES POINTERS AND PARAMETERS • RETURNS FROM INTERRUPT 	<p>During the Hunt mode, the SIO detects two contiguous characters to establish synchronization. The CPU establishes the DMA mode and all subsequent data characters are transferred by the DMA controller. The controller is also programmed to capture special characters (i.e. framing only the bits that specify Asc. 0 EBCDIC control characters) and inform the CPU upon detection. In response the CPU examines the status of control characters and takes appropriate action (e.g. CRC Enable Update)</p> <p>The SIO interrupts the CPU for error condition, and the error routine aborts present message. Clears the error condition, and repeats the operation</p>
TERMINATION	<p>REDEFINE INTERRUPT MODES AND SYNC MODES</p> <p>UPDATE MODEM CONTROLS</p> <p>DISABLES RECEIVE MODE</p>	

Table 6. Bisync Receive Mode (Continued)

The Z80-SIO is capable of handling both High-level Synchronous Data Link Control (HDLC) and IBM Synchronous Data Link Control (SDLC) protocols. In the following text, only SDLC is referred to because of the high degree of similarity between SDLC and HDLC.

The SDLC mode is considerably different than Synchronous Bisync protocol because it is bit oriented rather than character oriented and, therefore, can naturally handle transparent operation. Bit orientation makes SDLC a flexible protocol in terms of message length and bit patterns. The Z80-SIO has several built-in features to handle variable message length. Detailed information concerning SDLC protocol can be found in literature published on this subject, such as IBM document GA27-5093.

The SDLC message, called the frame (Figure 8), is opened and closed by flags that are similar to the sync characters in Bisync protocol. The Z80-SIO handles the transmission and recognition of the flag characters that mark the beginning and end of the frame. Note that the Z80-SIO can receive shaded-zero flags, but cannot transmit them. The 8-bit address field of an SDLC frame contains the secondary station address. The Z80-SIO has an Address Search mode that recognizes the secondary station address so it can accept or reject the frame.

Since the control field of the SDLC frame is transparent to the Z80-SIO, it is simply transferred to the CPU. The Z80-SIO handles the Frame Check sequence in a manner that simplifies the program by incorporating features such as initializing the CRC generator to all 1's, resetting the CRC checker when the opening flag is detected in the Receive mode, and sending the Frame Check/Flag sequence in the Transmit mode. Controller hardware is simplified by automatic zero insertion and deletion logic contained in the Z80-SIO.

Table 7 shows the contents of WR3, WR4 and WR5 during SDLC Receive and Transmit modes. WR0 points to other registers and issues various commands. WR1 defines the interrupt modes. WR2 stores the interrupt vector. WR3 stores the flag character and WR4 the secondary address.

SDLC Transmit

INITIALIZATION

Like Synchronous operation, the SDLC Transmit mode must be initialized with the following parameters: SDLC mode, SDLC polynomial, Request To Send, Data Terminal Ready, transmit character length, transmit interrupt modes (or Wait/Ready function), Transmit Enable, Auto Enables and External/Status Interrupt.

Selecting the SDLC mode and the SDLC polynomial enables the Z80-SIO to initialize the CRC Generator to all 1's. This is accomplished by issuing the Reset Transmit CRC Generator command (WR0, Refer to the Synchronous Operation section for more details on the interrupt modes).

After reset, or when the transmitter is not enabled, the Transmit Data output is held marking Break and can be programmed to generate a spacing line. When the transmitter fully initialized and enabled, continuous flags are transmitted on the Transmit Data output.

An abort sequence may be sent by issuing the Send Abort command (WR0, C510). This causes at least eight, but less than fourteen, 1's to be sent before the line reverts to continuous flags. It is possible that the Abort sequence (eight 1's) could follow up to five contiguous 0 bits (followed by the zero inversion logic) and thus cause up to thirteen 1's to be sent. Any data being transmitted and any data in the transmit buffer is lost when an abort is issued.

When required, an extra 0 is automatically inserted when there are five contiguous 1's in the data stream. This does not apply to flags or aborts.

DATA TRANSFER AND STATUS MONITORING

There are several combinations of interrupts and the Wait/Ready function in the SDLC mode.

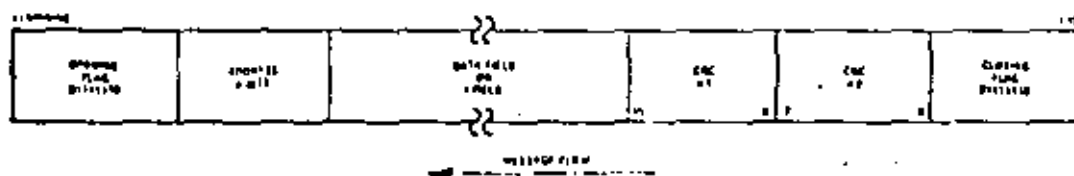

Figure 8. Transmit/Receive SDLC/HDLC Message Format

Data Transfer Using Interrupts. If the Transmit Interrupt Enable bit is set, an interrupt is generated each time the buffer becomes empty. The interrupt may be satisfied either by writing another character into the transmitter or by resetting the Transmit Interrupt Pending latch with a Reset Transmitter Pending command (WR0, 00). If the interrupt is satisfied with this command and nothing more is written into the transmitter, there are no further transmitter interrupts. The result is a Transmit Underrun condition. When another character is written and sent out, the transmitter can again become empty and interrupt the CPU. Following the flags in an SDLC operation, the 8-bit address field, control field and information field may be sent to the Z80-SIO using the Transmit Interrupt mode. The Z80-SIO transmits the Frame Check sequence using the Transmit Underrun feature.

When the transmitter is first enabled, it is already empty and obviously cannot then become empty. Therefore, no Transmit Buffer Empty interrupts can occur until after the first data character is written.

When the transmitter is first enabled, it is already empty and cannot then become empty. Therefore, no Transmit Buffer Empty interrupts can occur until after the first data character is written.

Data Transfer Using Wait/Ready. If the Wait/Ready function has been selected, WAIT indicates to the CPU that the Z80-SIO is not ready to accept the data and the CPU must extend the I/O cycle. To a DMA controller, WAIT indicates that the transmitter buffer is empty and the Z80-SIO is ready to accept the next character. If a character is not loaded into the Z80-SIO by the time the transmit shift register is empty, the Z80-SIO enters the Transmit Underrun condition. Address, control and information fields may be transferred to the Z80-SIO with this mode using the Wait/Ready function. The Z80-SIO transmits the Frame Check sequence using the Transmit Underrun feature.

SDLC Transmit Underrun/End Of Message. SDLC like protocols do not have provisions for fill characters within a message. The Z80-SIO therefore automatically terminates an SDLC frame when the transmit data buffer and output shift register have no more bits to send, does this by first sending the two bytes of CRC and following these with one or more flags. This technique allows very high-speed transmissions under DMA or CPU block I/O control without requiring the CPU to respond quickly to the end of message situation.

The action that the Z80-SIO takes in the underrun situation depends on the state of the Transmit Underrun/EOM command. Following a reset, the Transmit Underrun/EOM status bit is in the set state and prevents the insertion of CRC characters during the time there is no data to send. Consequently, flag characters are sent. The Z80-SIO begins to send the frame as data is written into the transmit buffer. Between the time the first data byte is written and the end of the message, the Reset Transmit Underrun/EOM command must be issued. Thus the Transmit Underrun/EOM status bit is in the reset state at the end of the message (when underrun occurs), which automatically sends the CRC characters. The sending of CRC again sets the Transmit/Underrun/EOM status bit.

Although there is no restriction as to when the Transmit Underrun/EOM bit can be reset within a message, it is usually reset after the first data character (secondary address) is sent to the Z80-SIO. Resetting this bit allows CRC and flags to be sent when there is no data to send which gives additional time to the CPU for recognizing the fault and responding with an abort command. By resetting it early in the message, the entire message has the maximum amount of CPU response time in an unintentional transmit underrun situation.

	BIT 7	BIT 6	BIT 5	BIT 4	BIT 3	BIT 2	BIT 1	BIT 0
WR3	00 = R _x 5 BITS CHAR 10 = R _x 6 BITS CHAR 01 = R _x 7 BITS CHAR 11 = R _x 8 BITS CHAR		AUTO ENABLES	ENTERHUNT MODE (IF INCOMING DATA NOT NEEDED)	R _x CRC ENABLE	ADDRESS SEARCH MODE	0	R _x ENABLE
WR4	0	0	1 0 SELECTS SDLC MODE		0	0	0	0
WR5	DTR	00 = T _x 5 BITS (OR LESS) CHAR 10 = T _x 6 BITS CHAR 01 = T _x 7 BITS CHAR 11 = T _x 8 BITS CHAR		0	T _x ENABLE	0 SELECTS SDLC CRC	RTS	T _x CRC ENABLE

Table 7. Contents of Write Registers 3, 4 and 5 in SDLC Modes

When the External/Status interrupt is set and while a message is being sent, the Transmit Underrun/EOM bit is set and the Transmit Buffer Empty bit is reset to indicate that the transmit register is full of CRC data. When CRC has been completely sent, the Transmit Buffer Empty status bit is set and an interrupt is generated to indicate to the CPU that another message can begin. This interrupt occurs because CRC has been sent and the flag has been loaded. If no more messages are to be sent, the program can terminate transmission by resetting RTS, and disabling the transmitter.

In the SDLC mode, it is good practice to reset the Transmit Underrun/EOM status bit immediately after the first character is sent to the Z80-SIO. When the Transmit Underrun is detected, this ensures that the transmission time is filled by CRC characters, giving the CPU enough time to issue the Send Abort command. This also stops the flags from going on the line prematurely and eliminates the possibility of the receiver accepting the frame as valid data. The situation can happen because it is possible that—at the receiving end—the data pattern immediately preceding the automatic flag insertion could match the CRC checker, giving a false CRC check result. The External/Status interrupt is generated whenever the Transmit Underrun/EOM bit is set because of the Transmit Underrun condition.

The transmit underrun logic provides additional protection against premature flag insertion if the proper response is given to the Z80-SIO by the CPU interrupt service routine. The following example is given to clarify this point:

The Z80 SIO raises an interrupt with the Transmit Buffer Empty status bit set.

The CPU does not respond in time and causes a Transmit Underrun condition.

The Z80-SIO starts sending CRC characters (two bytes).

The CPU eventually satisfies the Transmit Buffer Empty interrupt with a data character that follows the CRC character being transmitted.

The Z80 SIO sets the External/Status interrupt with the Transmit Underrun/EOM status bit set.

The CPU recognizes the Transmit Underrun/EOM status and determines from its internal program status that the interrupt is not for "end of message".

The CPU immediately issues a Send Abort Command (WAB) to the Z80 SIO.

The Z80 SIO sends the Abort sequence by destroying whatever data (CRC, data or flag) is being sent.

This sequence illustrates that the CPU has a protection of 22 minimum and 30 maximum transmit clock cycles.

SDLC CRC Generation. The CRC generator must be reset to all 1's at the beginning of each frame before CRC accumulation can begin. Actual accumulation begins when the program sends the address field (eight bits) to the Z80-SIO. Although the Z80-SIO automatically

transmits one flag character following the Transmit Enable, it may be wise to send a few more flag characters ahead of the message to ensure character synchronization at the receiving end. This can be done by externally timing out after enabling the transmitter and before loading the first character.

The Transmit CRC Enable (WR5, D₆) should be enabled prior to sending the address field. In the SDLC mode all the characters between the opening and closing flags are included in CRC accumulation, and the CRC generated in the Z80-SIO transmitter is inverted before it is sent on the line.

Transmit Termination. If the transmitter is disabled while a character is being sent, that character (data or flag) is sent in the normal fashion, but is followed by a marking line rather than CRC or flag characters.

A character in the buffer when the transmitter is disabled remains in the buffer; however, a programmed Abort sequence is effective as soon as it is written into the control register. Characters being transmitted, if any, are lost. In the case of CRC, the 16-bit transmission is completed if the transmitter is disabled; however, flags are sent in place of CRC.

In all modes, characters are sent with the least-significant bits first. This requires right-hand justification of data to be transmitted if the word length is less than eight bits. If the word length is five bits or less, the special technique described in the Write Register 5 section ("Z80-SIO Programming" chapter; "Write Registers" section) must be used.

Since the number of bits/character can be changed on the fly, the data field can be filled with any number of bits. When used in conjunction with the Receiver Residue codes, the Z80-SIO can receive a message that has a variable I-field and retransmit it exactly as received with no previous information about the character structure of the I-field (if any). A change in the number of bits does not affect the character in the process of being shifted out. Characters are sent with the number of bits programmed at the time that the character is loaded from the transmit buffer to the transmitter.

If the External/Status Interrupt Enable is set, transmitter conditions such as "starting to send CRC characters," "starting to send flag characters," and CTS changing state cause interrupts that have a unique vector if Status Affects Vector is set. All interrupts can be disabled for operation in a polled mode.

Table 8 shows the typical program steps that implement the half-duplex SDLC Transmit mode.

Z80™ CTC
Z80A™ CTC
Technical Manual

TABLE OF CONTENTS

1.0	Introduction	123	1
2.0	CTC Architecture		2
2.1	Overview		2
2.2	Structure of Channel Logic		3
2.2.1	The Channel Control		3
2.2.2	The Prescaler		4
2.2.3	The Time Constant Register		4
2.2.4	The Down Counter		4
2.3	Interrupt Control Logic		5
3.0	CTC Pin Description		6
4.0	CTC Operating Modes		9
4.1	CTC Counter Mode		9
4.2	CTC Timer Mode		10
5.0	CTC Programming		11
5.1	Loading the Channel Control Register		11
5.2	Loading the Time Constant Register		14
5.3	Loading the Interrupt Vector Register		15
6.0	CTC Timing		16
6.1	CTC Write Cycle		16
6.2	CTC Read Cycle		17
6.3	CTC Counting and Timing		18
7.0	CTC Interrupt Servicing		19
7.1	Interrupt Acknowledge Cycle		19
7.2	Return from Interrupt Cycle		20
7.3	Daisy Chain Interrupt Servicing		21
8.0	Absolute Maximum Ratings		22
8.1	D.C. Characteristics		22
8.2	Capacitance		22
8.3	A.C. Characteristics		23
8.4	A.C. Timing Diagram		24
8.5	A.C. Characteristics		25
8.6	Package Configuration and Package Outline		26

The Z80 Counter Timer Circuit (CTC) is a programmable component with four independent channels that provide counting and timing functions for microcomputer systems based on the Z80-CPU. The CPU can configure the CTC channels to operate under various modes and conditions as required to interface with a wide range of devices. In most applications, little or no external logic is required. The Z80 CTC utilizes N-channel silicon gate depletion load technology and is packaged in a 28-pin DIP. The Z80 CTC requires only a single 5 volt supply and a one-phase 5 volt clock. Major features of the Z80-CTC include:

- All inputs and outputs fully TTL compatible.
- Each channel may be selected to operate in either Counter Mode or Timer Mode.
- Used in either mode, a CPU-readable Down Counter indicates number of counts-to-go until zero.
- A Time Constant Register can automatically reload the Down Counter at Count Zero in Counter and Timer Mode.
- Selectable positive or negative trigger initiates time operation in Timer Mode. The same input is monitored for event counts in Counter Mode.
- Three channels have Zero Count/Timeout outputs capable of driving Darlington transistors.
- Interrupts may be programmed to occur on the zero count condition in any channel.
- Daisy chain priority interrupt logic included to provide for automatic interrupt vectoring without external logic.

2.0 CTC ARCHITECTURE

2.1 OVERVIEW

A block diagram of the Z80-CTC is shown in figure 2.0-1. The internal structure of the Z80-CTC consists of a Z80 CPU bus interface, Internal Control Logic, four sets of Counter/Timer Channel Logic, and Interrupt Control Logic. The four independent counter/timer channels are identified by sequential numbers from 0 to 3. The CTC has the capability of generating a unique interrupt vector for each separate channel (for automatic vectoring to an interrupt service routine). The 4 channels can be connected into four contiguous slots in the standard Z80 priority chain with channel number 0 having the highest priority. The CPU bus interface logic allows the CTC device to interface directly to the CPU with no other external logic. However, port address decoders and/or line buffers may be required for large systems.

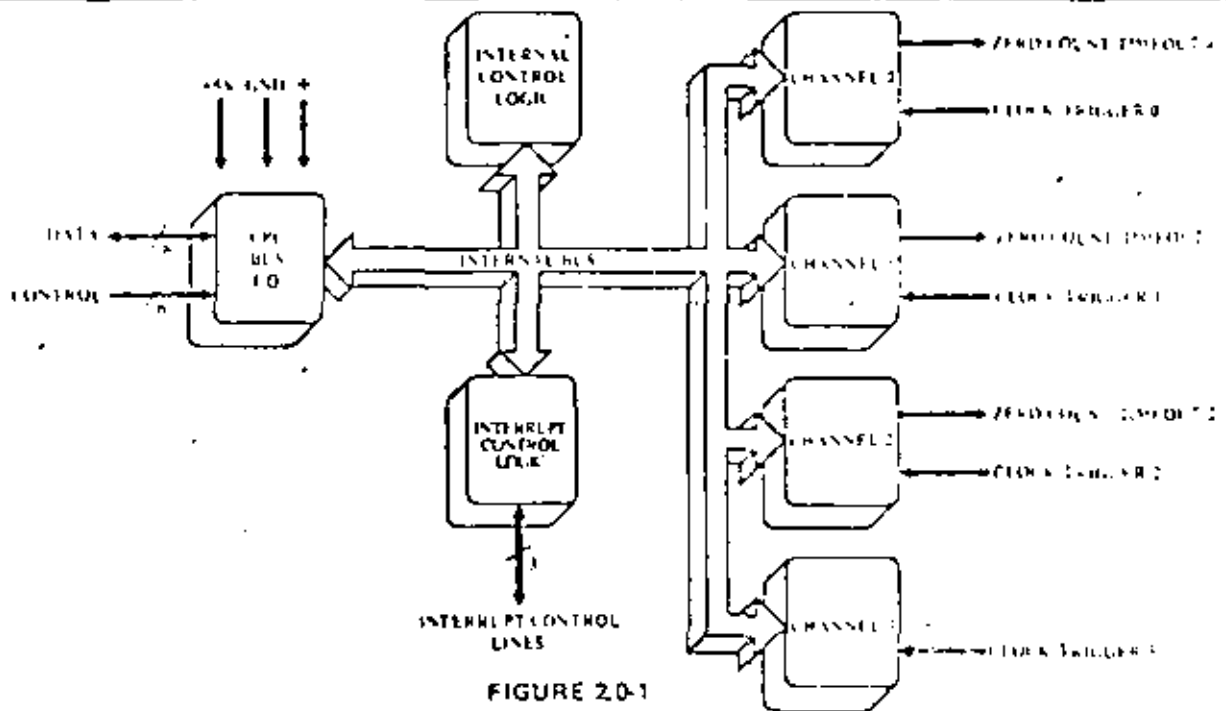

2.2 STRUCTURE OF CHANNEL LOGIC

The structure of one of the four sets of Counter/Timer Channel Logic is shown in figure 2.0-2. This logic is composed of 2 registers, 2 counters and control logic. The registers are an 8-bit Time Constant Register and an 8-bit Channel Control Register. The counters are an 8-bit CPU-readable Down Counter and an 8-bit Prescaler.

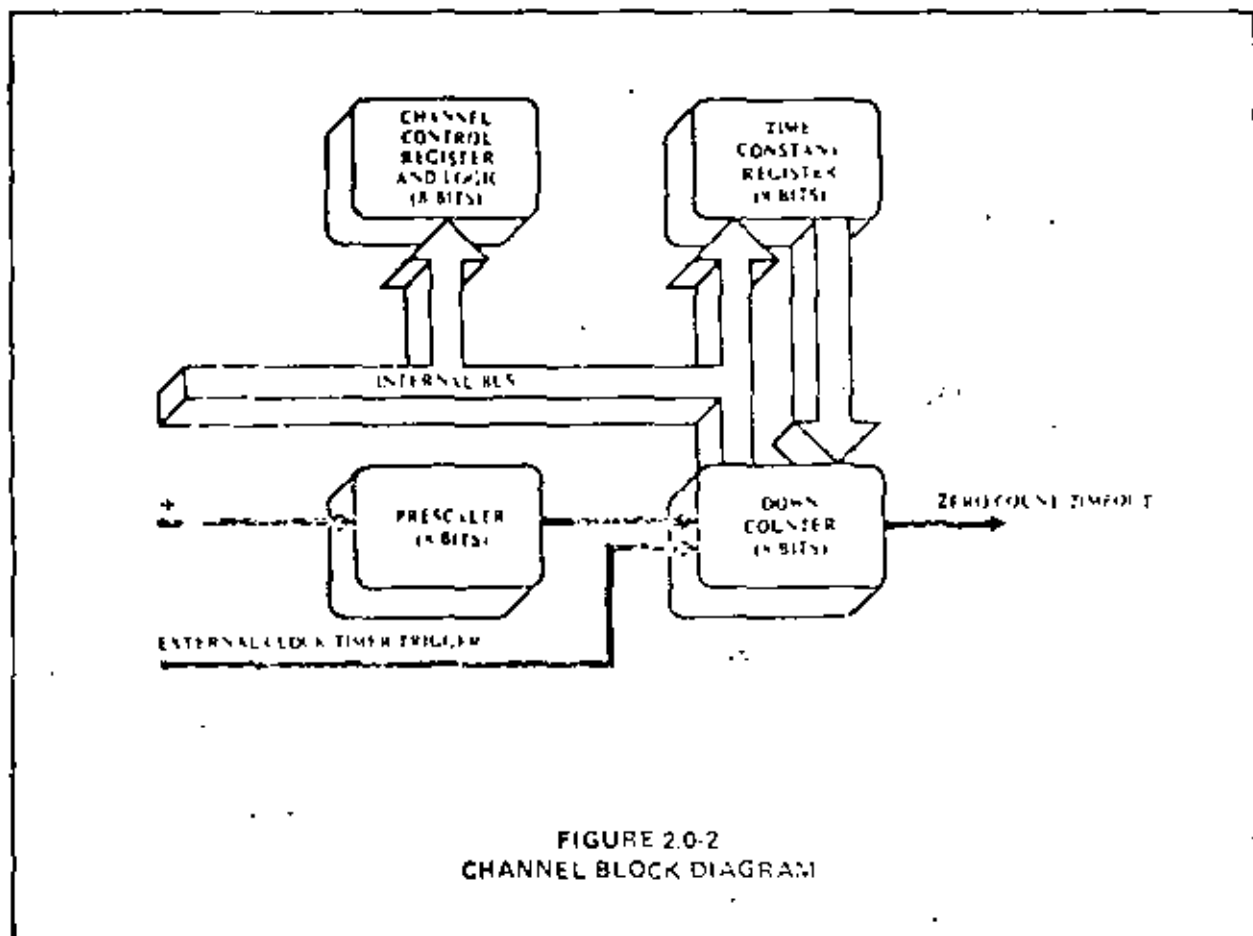

FIGURE 2.0-2
CHANNEL BLOCK DIAGRAM

2.2.1 THE CHANNEL CONTROL REGISTER AND LOGIC

The Channel Control Register (8-bit) and Logic is written to by the CPU to select the modes and parameters of the channel. Within the entire CTC device there are four such registers, corresponding to the four Counter/Timer Channels. Which of the four is being written to depends on the encoding of two channel select input pins, CS0 and CS1 (usually attached to A0 and A1 of the CPU's address bus). This is illustrated in the truth table below.

	CS1	CS0
Ch 0	0	0
Ch 1	0	1
Ch 2	1	0
Ch 3	1	1

2.2.1 CONTINUED

In the control word written to program each Channel Control Register, bit 0 is always set, and the other 7 bits are programmed to select alternatives on the channel's operating modes and parameters, as shown in the diagram below. (For a more complete discussion see section 4.0, "CTC Operating Modes" and section 5.0 "CTC Programming.")

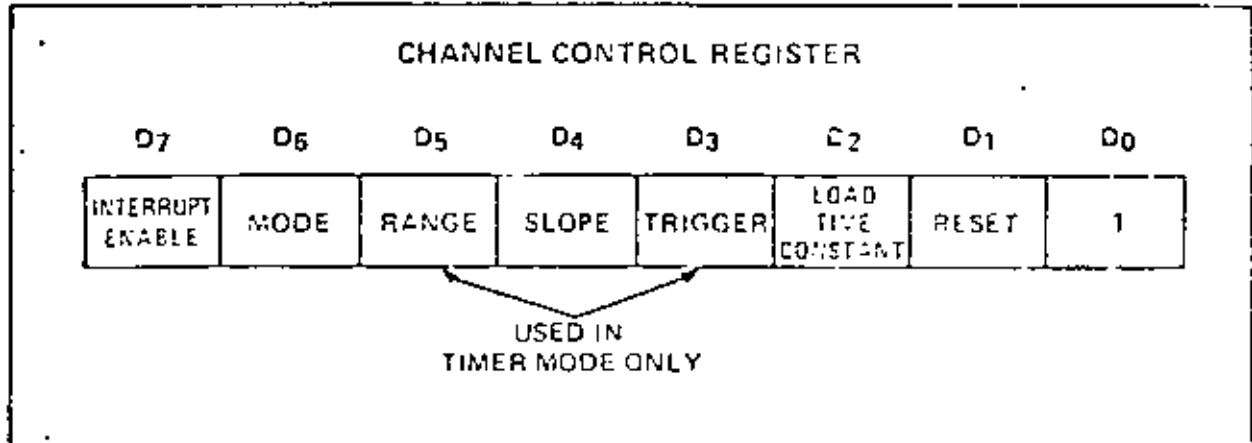

2.2.2 THE PRESCALER

Used in the Timer Mode only, the Prescaler is an 8-bit device which can be programmed by the CPU into the Channel Control Register, to divide its input, the System Clock (10), by 1 to 256. The output of the Prescaler is then fed as an input to clock the Down Counter, which initially 7 and every time it clocks down to zero, is reloaded automatically with the contents of the Time Constant Register. In effect this again divides the System Clock by an additional factor of the time constant. Every time the Down Counter counts down to zero, its output, Zero Count Output (ZC/TO), is pulsed high.

2.2.3 THE TIME CONSTANT REGISTER

The Time Constant Register is an 8-bit register, used in both Counter Mode and Timer Mode, programmed by the CPU just after the Channel Control Word with an integer time constant value of 1 through 256. This register loads the programmed value into the Down Counter when the CTC is first initialized and reloads the same value into the Down Counter automatically whenever it counts down thereafter to zero. If a new time constant is loaded into the Time Constant Register while a channel is counting or timing, the present down count will be completed before the new time constant is loaded into the Down Counter. (For details of how a time constant is written to a CTC channel, see section 5.0: "CTC Programming.")

2.2.4 THE DOWN COUNTER

The Down Counter is an 8-bit register, used in both Counter Mode and Timer Mode, loaded initially, and later when it counts down to zero, by the Time Constant Register. The Down Counter is decremented by each external clock edge in the Counter Mode, or in the Timer Mode, by the clock output of the Prescaler. At any time, by performing a simple I/O Read at the port address assigned to the selected CTC channel, the CPU can access the contents of this register and obtain the number of counts to zero. Any CTC channel may be programmed to generate an interrupt request sequence each time the zero count is reached.

In channels 0, 1, and 2, when the zero count condition is reached, a signal pulse appears at the corresponding ZC/IO pin. Due to package pin limitations, however, channel 3 does not have this pin and so may be used only in applications where this output pulse is not required.

2.3 INTERRUPT CONTROL LOGIC

The Interrupt Control Logic insures that the CTC acts in accordance with Z80 system interrupt protocol for nested priority interrupting and return from interrupt. The priority of any system device is determined by its physical location in a daisy chain configuration. Two signal lines (I/I and I/O) are provided in CTC devices to form this system daisy chain. The device closest to the CPU has the highest priority; within the CTC, interrupt priority is predetermined by channel number, with channel 0 having highest priority down to channel 3 which has the lowest priority. The purpose of a CTC-generated interrupt, as with any other peripheral device, is to force the CPU to execute an interrupt service routine. According to Z80 system interrupt protocol, lower priority devices or channels may not interrupt higher priority devices or channels that have already interrupted and have not had their interrupt service routines completed. However, high priority devices or channels may interrupt the servicing of lower priority devices or channels.

* A CTC channel may be programmed to request an interrupt every time its Down Counter reaches a count of zero. (To utilize this feature requires that the CPU be programmed for interrupt mode 2.) Some time after the interrupt request, the CPU will send out an interrupt acknowledge, and the CTC's Interrupt Control Logic will determine the highest priority channel which is requesting an interrupt within the CTC device. Then if the CTC's I/I input is active, indicating that it has priority within the system daisy chain, it will place an 8-bit Interrupt Vector on the system data bus. The high-order 5 bits of this vector will have been written to the CTC earlier as part of the CTC initial programming process; the next two bits will be provided by the CTC's Interrupt Control Logic as a binary code corresponding to the highest-priority channel requesting an interrupt; finally the low-order bit of the vector will always be zero according to a convention described below.

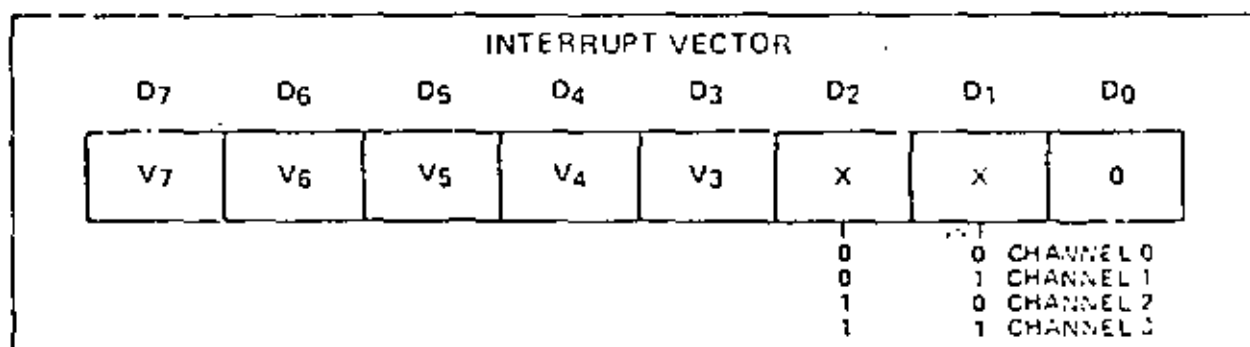

This interrupt vector is used to form a pointer to a location in memory where the address of the interrupt service routine is stored in a table. The vector represents the least significant 8 bits, while the CPU reads the contents of the I register to provide the most significant 8 bits of the 16-bit pointer. The address in memory pointed to will contain the low-order byte, and the next highest address will contain the high-order byte of the address which in turn contains the first opcode of the interrupt service routine. Thus in mode 2, a single 8-bit vector stored in an interrupting CTC can result in an indirect call to any memory location.

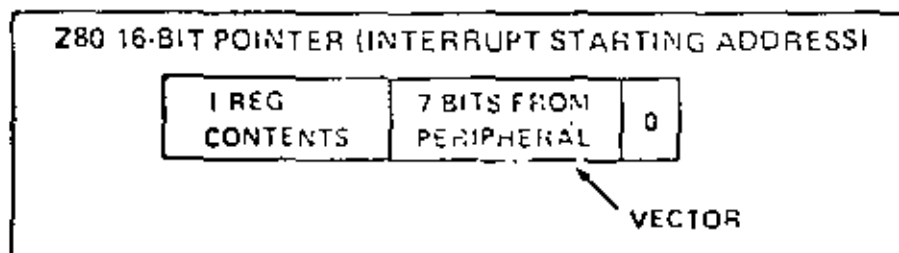

There is a Z80 system convention that all addresses in the interrupt service routine table should have their low-order byte in an even location in memory, and their high-order byte in the next highest location in memory, which will always be odd so that the least significant bit of any interrupt vector will always be even. Hence the least significant bit of any interrupt vector will always be zero.

The RETI instruction is used at the end of any interrupt service routine to initialize the daisy chain enable line I/O for proper control of nested priority interrupt handling. The CTC monitors the system data bus and decodes this instruction when it occurs. Thus the CTC channel control logic will know when the CPU has completed servicing an interrupt, without any further communication with the CPU being necessary.

3.0 CTC PIN DESCRIPTION

A diagram of the Z80 CTC pin configuration is shown in figure 3.0-1. This section describes the function of each pin.

D7 - D0

Z80-CPU Data Bus (bi-directional, tri-state)

This bus is used to transfer all data and command words between the Z80-CPU and the Z80-CTC. There are 8 bits on this bus, of which D0 is the least significant.

CS1 - CS0

Channel Select (input, active high)

These pins form a 2-bit binary address code for selecting one of the four independent CTC channels for an I/O Write or Read. (See truth table below.)

	CS1	CS0
Ch 0	0	0
Ch 1	0	1
Ch 2	1	0
Ch 3	1	1

CE

Chip Enable (input, active low)

A low level on this pin enables the CTC to accept control words, Interrupt Vectors, or time constant data words from the Z80 Data Bus during an I/O Write cycle, or to transmit the contents of the Down Counter to the CPU during an I/O Read cycle. In most applications this signal is decoded from the 5 least significant bits of the address bus for any of the four I/O port addresses that are mapped to the four Counter/Timer Channels.

Clock (Φ)

System Clock (input)

This single-phase clock is used by the CTC to synchronize certain signals internally.

$\overline{M1}$

Machine Cycle One Signal from CPU (input, active low)

When $\overline{M1}$ is active and the \overline{RD} signal is active, the CPU is fetching an instruction from memory. When $\overline{M1}$ is active and the \overline{IORQ} signal is active, the CPU is acknowledging an interrupt, letting the CTC to place an Interrupt Vector on the Z80 Data Bus if it has daisy-chain priority and one of its channels has requested an interrupt.

\overline{IORQ}

Input/Output Request from CPU (input, active low)

The \overline{IORQ} signal is used in conjunction with the \overline{CE} and \overline{RD} signals to transfer data and Channel Control Words between the Z80-CPU and the CTC. During a CTC Write Cycle, \overline{IORQ} and \overline{CE} must be true and \overline{RD} false. The CTC does not receive a tri-state write signal, and generates its own internally from the inverse of a valid \overline{RD} signal. In a CTC Read Cycle, \overline{IORQ} , \overline{CE} , and \overline{RD} must be active to place the contents of the Down Counter on the Z80 Data Bus. If \overline{IORQ} and $\overline{M1}$ are both true, the CPU is acknowledging an interrupt request, and the highest-priority interrupting channel will place its Interrupt Vector on the Z80 Data Bus.

\overline{RD}

Read Cycle Status from the CPU (input, active low)

The \overline{RD} signal is used in conjunction with the \overline{IORQ} and \overline{CE} signals to transfer data and Channel Control Words between the Z80 CPU and the CTC. During a CTC Write Cycle, \overline{IORQ} and \overline{CE} must be true and \overline{RD} false. The CTC does not receive a specific write signal, instead generating its own internally from the inverse of a valid \overline{RD} signal. In a CTC Read Cycle, \overline{IORQ} , \overline{CE} and \overline{RD} must be active to place the contents of the Down Counter on the Z80 Data Bus.

IEI

Interrupt Enable In (input, active high)

This signal is used to help form a system-wide interrupt daisy chain which establishes priorities when more than one peripheral device in the system has interrupting capability. A high level on this pin indicates that no other interrupting devices of higher priority in the daisy chain are being serviced by the Z80 CPU.

IEO

Interrupt Enable Out (output, active high)

The IEO signal, in conjunction with IEI, is used to form a system-wide interrupt priority daisy chain. IEO is high only if IEI is high and the CPU is not servicing an interrupt from any CTC channel. Thus this signal blocks lower priority devices from interrupting while a higher priority interrupting device is being serviced by the CPU.

 \overline{INT}

Interrupt Request (output, open drain, active low)

This signal goes true when any CTC channel which has been programmed to enable interrupts has a zero-count condition in its Down Counter.

 \overline{RESET}

Reset (input, active low)

This signal stops all channels from counting and resets channel interrupt enable bits in all control registers, thereby disabling CTC-generated interrupts. The ZC/T0 and \overline{INT} outputs go to their inactive states, IEO reflects IEI, and the CTC's data bus output drivers go to the high impedance state.

CLK/TRG0 - CLK/TRG3

External Clock/Timer Trigger (input, user-selectable active high or low)

There are four CLK/TRG pins, corresponding to the four independent CTC channels. In the Counter Mode, every active edge on this pin decrements the Down Counter. In the Timer Mode, an active edge on this pin initiates the timing function. The user may select the active edge to be either rising or falling.

ZC/T0 - AC/T00

Zero Count/Time-out (output, active high)

There are three ZC/T0 pins, corresponding to CTC channels 2 through 0. (Due to package pin limitations, channel 1 has no ZC/T0 pin.) In either Counter Mode or Timer Mode, when the Down Counter decrements to zero an active high going pulse appears at this pin.

3.0 CTC PIN DESCRIPTION

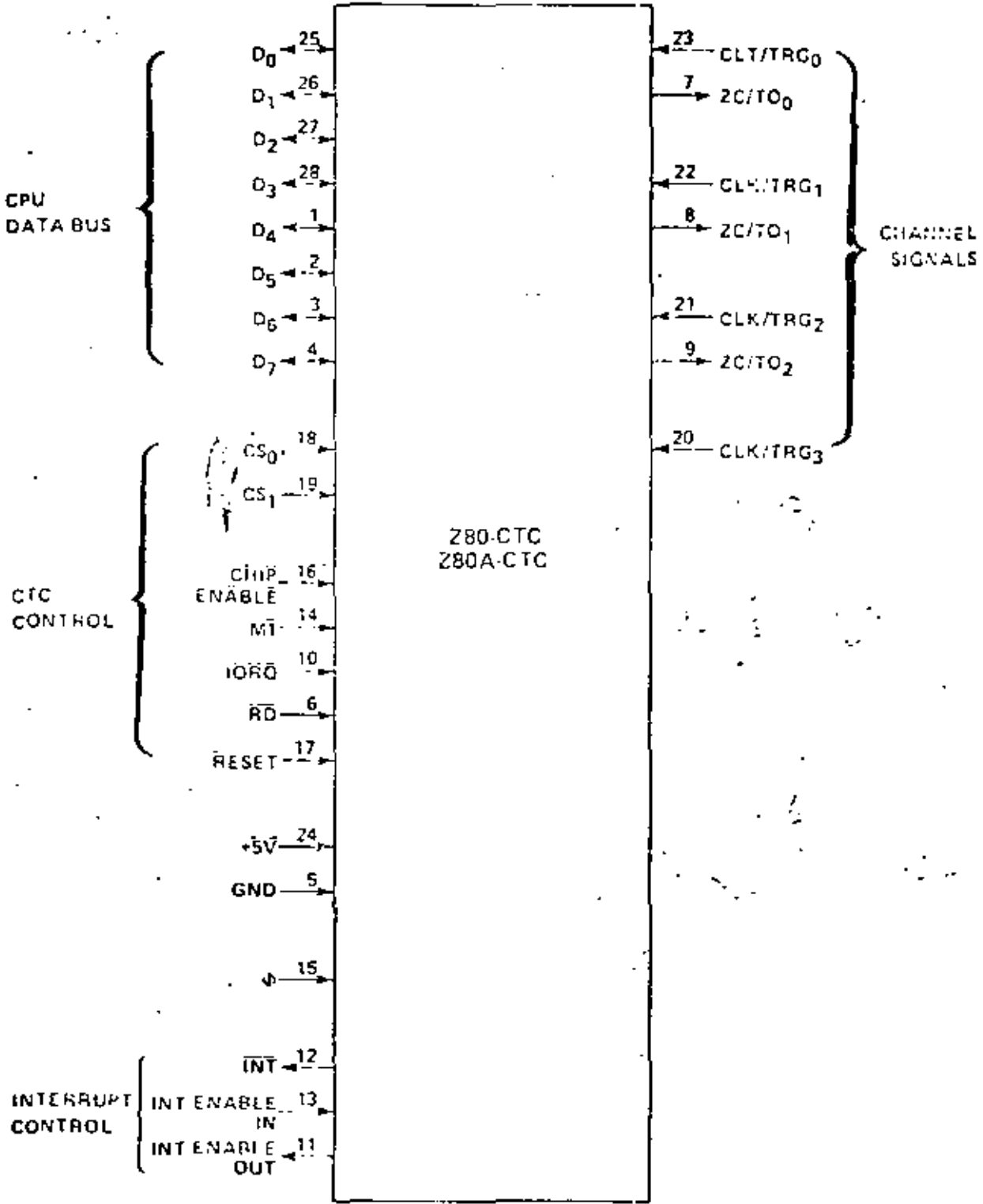

FIGURE 3.0 1
CTC PIN CONFIGURATION

4.0 CTC OPERATING MODES

At power-on, the 7x0-CTC state is undefined. A rising RESET puts the CTC in a known state. Before any channel can begin counting or timing, a Channel Control Word and a time constant data word must be written to the appropriate registers of that channel. Further, if any channel has been programmed to generate interrupts, an Interrupt Vector word must be written to the CTC's Interrupt Control Logic. (For further details, refer to section 7.0 "CTC Programming.") When the CPU has written all of these words to the CTC, all active channels will be programmed for immediate operation in either the Counter Mode or the Timer Mode.

4.1 CTC COUNTER MODE

In this mode, the CTC counts edges of the CLK TRG input. The Counter Mode is programmed for a channel when its Channel Control Word is written with bit 6 set. The Channel's External Clock (CLK TRG) input is monitored for a series of triggering edges; after each, in synchronization with the next rising edge of the System Clock, the Down Counter (which was initialized with the time constant data word at the start of any sequence of down-counting) is decremented. Although there is no set-up time requirement between triggering edges of the External Clock and the rising edge of the System Clock, the Down Counter will not be decremented until the following ϕ pulse. (See the parameter ts(CS) in section 8.3 "TAC Characteristics.") A channel's External Clock input is pre-programmed by bit 4 of the Channel Control Word to trigger the down-counting sequence with either a high or a low going edge.

In any of Channels 1, 2, or 3 when the Down Counter is successively decremented from the original time constant until it reaches zero, the Zero Count (ZC) output pin for that channel will be pulled active (high). (However, due to package pin limitations, channel 3 does not have the pin and therefore only be used in applications where the output pulse is not required.) Further, if the channel has been pre-programmed by bit 7 of the Channel Control Word, an interrupt output sequence will be generated. (For more details, see section 7.0 "CTC Interrupt Sequencing.")

As the channel continues to proceed through the zero count condition, also results in the automatic loading of the Down Counter with the original time constant data word in the Time Constant Register. There is no interruption in the sequence of continued down-counting if the Time Constant Register is written to with a new time constant data word while the Down Counter is decrementing; the present count will be completed before the new time constant will be loaded into the Down Counter.

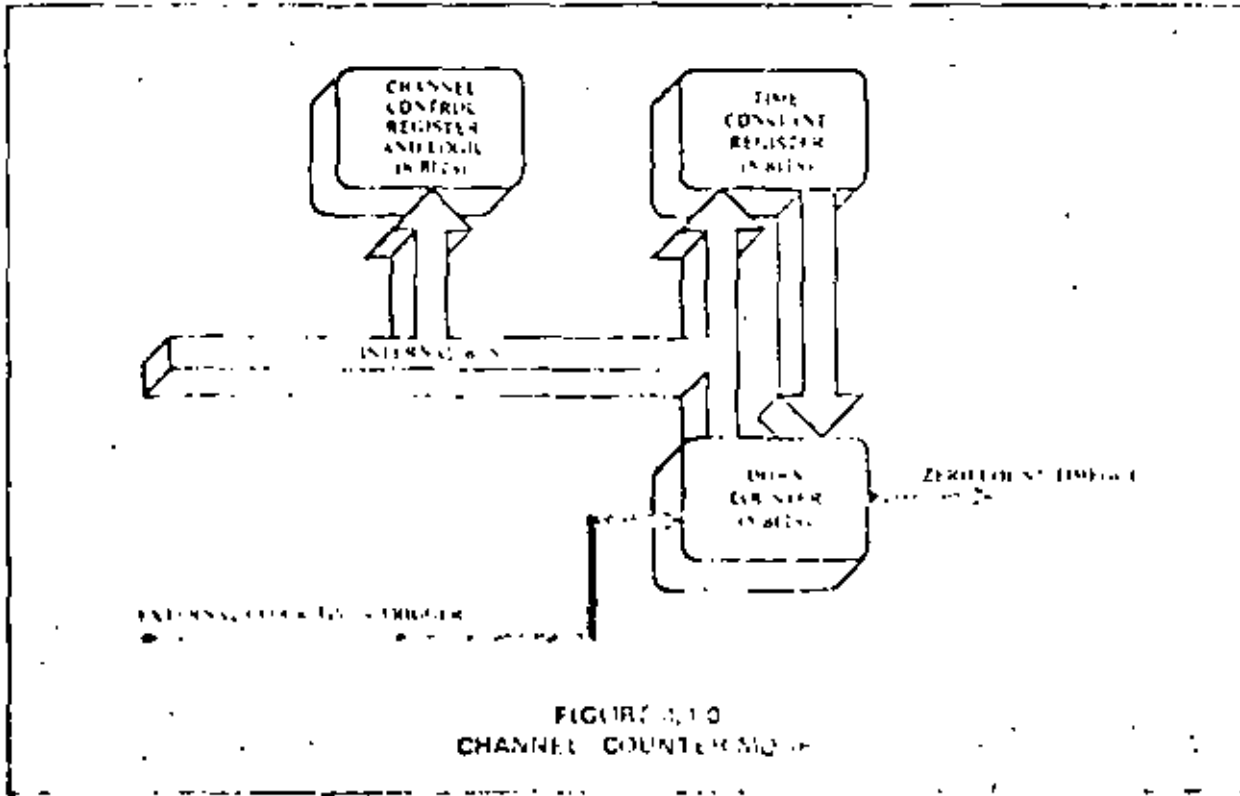

FIGURE 4.10 CHANNEL COUNTER MODE

4.7 CTC TIMER MODE

The period T of the CTC signal is defined as the interval at an appropriate rate of the system clock Φ period. The Timer Mode is implemented by a channel and when its Channel Control Word is written with bit 6 set, the channel generates a square wave interval of time based on the System Clock period. The System Clock is fed through two 8-bit counters, the Prescaler and the Down Counter. Depending on the pre-programmed bit 5 in the Channel Control Word, the Prescaler divides the System Clock by a factor of either 16 or 256. The output of the Prescaler is used as a clock to increment the Down Counter which may be pre-programmed with any time constant integer between 1 and 255. As in the Counter Mode, the time constant is automatically reloaded to the Down Counter at each zero-count condition and counting continues. Also, as in Counter Mode, the channel's Time Out (TO) output (which is the output of the Down Counter) is pulsed, resulting in the binary frequency of pulses period given by the product,

$$T = \Phi \cdot P \cdot TC$$

where Φ is the System Clock period, P is the Prescaler factor of 16 or 256 and TC is the pre-programmed time constant.

Bit 5 of the Channel Control Word is pre-programmed to select whether timing will be initiated by a logic signal or whether it will be initiated with a triggering edge at the channel's Timer Trigger (TT) pin. If bit 5 is reset the timer automatically begins operation at the start of the first Φ following the first write cycle that loads the time constant data word to the channel. If bit 5 is set the timer begins operation on the second succeeding rising edge of Φ after the Timer Trigger edge following the loading of the time constant data word. If no time constant data word is to follow then the timer begins operation on the second succeeding rising edge of Φ after the Timer Trigger edge following the control word write cycle for 4 of the Channel Control Word is pre-programmed to select whether the Timer Trigger will be sensitive to a rising or falling edge. Although there is no set-up requirement between the active edge of the Timer Trigger and the active rising edge of Φ , if the Timer Trigger edge occurs closer than a specified minimum set-up time to the rising edge of Φ , the Down Counter will not begin decrementing until the following rising edge of Φ . (See parameter t_{ST} (TR) in section 8.3: "A.C. Characteristics".)

If bit 7 in the Channel Control Word is set, the zero-count condition in the Down Counter, besides causing a pulse at the channel's Time Out pin, will be used to initiate an interrupt request sequence. (For more details, see section 7.0 "CTC Interrupt Servicing".)

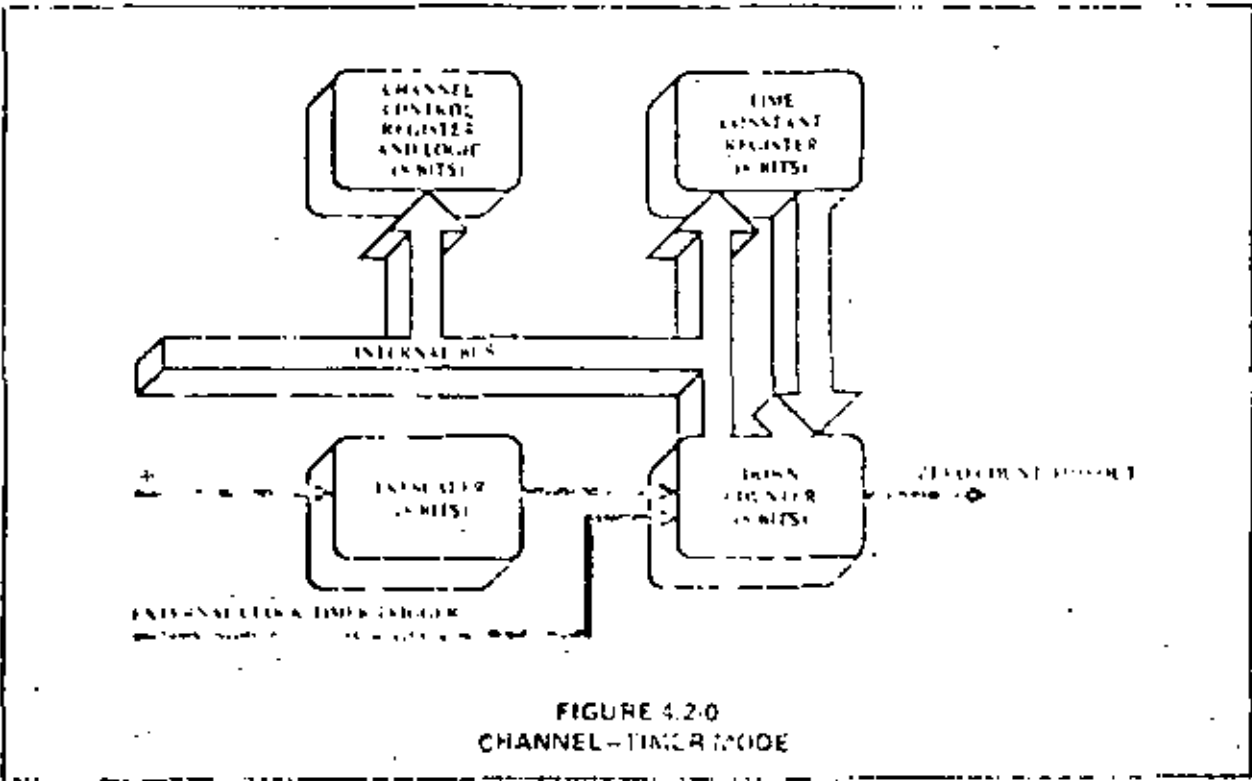

FIGURE 4.2.0
CHANNEL-TIMER MODE

5.0 CTC PROGRAMMING

Each of the 750 CTC channels can handle counting or timing operations, a Channel Control Word and a Time Constant data word must be written to it by the CPU. These words will be stored in the Channel Control Register and the Time Constant Register of that channel. In addition, if one of the four channels has been programmed with bit 7 of their Channel Control Words to enable interrupts, an Interrupt Vector can be written to the appropriate register in the CTC's DTR to automatic features in the Interrupt Control Logic, one pre-programmed Interrupt Vector address for all four channels.

5.1 LOADING THE CHANNEL CONTROL REGISTER

To load a Channel Control Word, the CPU performs a normal I/O write sequence to the port address of the device which is the desired CTC channel. Two CTC input pins, namely CS0 and CS1, are used to form a 2-bit binary address to select one of four channels within the device. (For a truth table, see section 2.2.1, "The Channel Control Register and Logic.") In many system architectures, these two input pins are connected to Address Buses A0 and A1, respectively, so that the four channels in a CTC device will occupy contiguous I/O port addresses. A word written to a CTC channel will be interpreted as a Channel Control Word, and loaded into the Channel Control Register, its bit 0 is a logic 1. The other seven bits of this word select operating modes and conditions as indicated in the diagram below. Following the diagram the meaning of each bit will be discussed in detail.

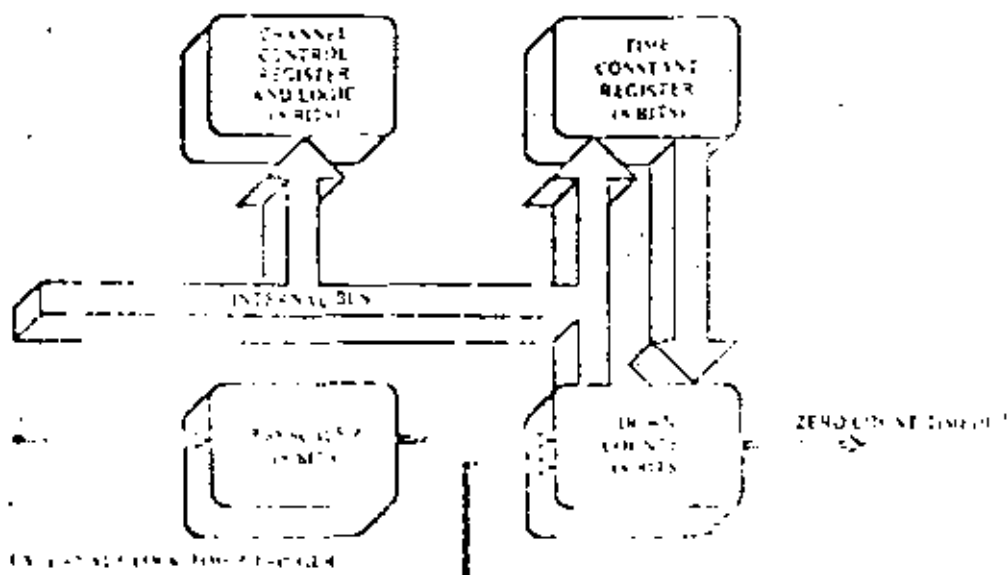
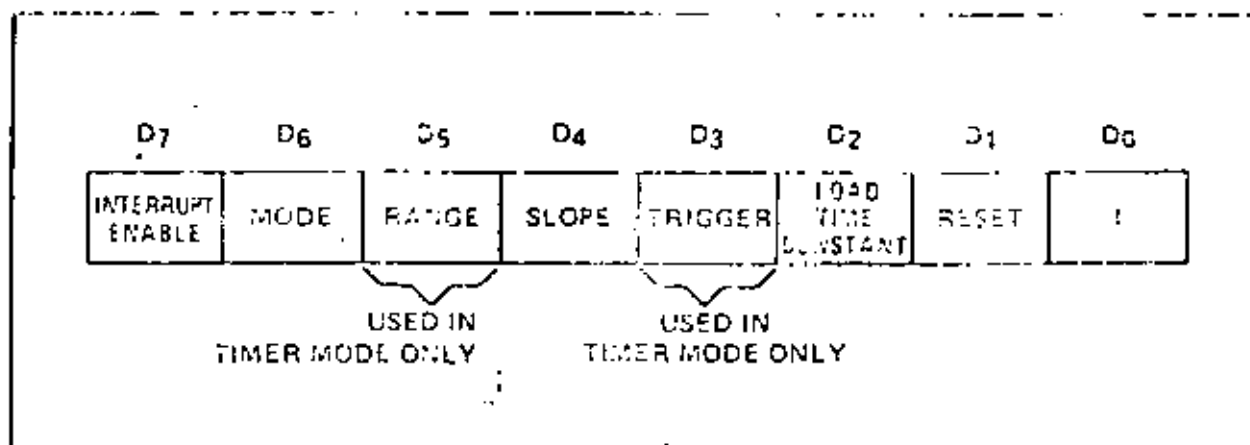

FIGURE 5.1-0
CHANNEL BLOCK DIAGRAM

5.1 LOADING THE CHANNEL CONTROL REGISTER (CONT'D)

**Bit 7 = 1**

The channel is enabled to generate an interrupt request sequence every time the Down Counter reaches a zero-count condition. To set this bit to 1 in any of the four Channel Control Registers necessitates that an Interrupt Vector also be written to the CTC before operation begins. Channel interrupts may be programmed in either Counter Mode or Timer Mode. If an updated Channel Control Word is written to a channel already in operation, with bit 7 set, the interrupt enable selection will not be retroactive to a preceding zero-count condition.

Bit 7 = 0

Channel interrupts disabled.

Bit 6 = 1

Counter Mode selected. The Down Counter is decremented by each triggering edge of the External Clock (CTC1/RC1) input. The Prescaler is not used.

Bit 6 = 0

Timer Mode selected. The Prescaler is clocked by the System Clock Φ_1 and the output of the Prescaler in turn clocks the Down Counter. The output of the Down Counter (the channel's ZC/IO output) is a train of pulse train of period given by the product:

$$T_c \cdot P \cdot TC$$

where T_c is the period of System Clock Φ_1 , P is the Prescaler factor of 16 or 256, and TC is the time constant data word.

Bit 5 = 1

(Defined for Timer Mode only.) Prescaler factor is 256.

Bit 5 = 0

(Defined for Timer Mode only.) Prescaler factor is 16.

5.1 LOADING THE CHANNEL CONTROL REGISTER (CONT'D)

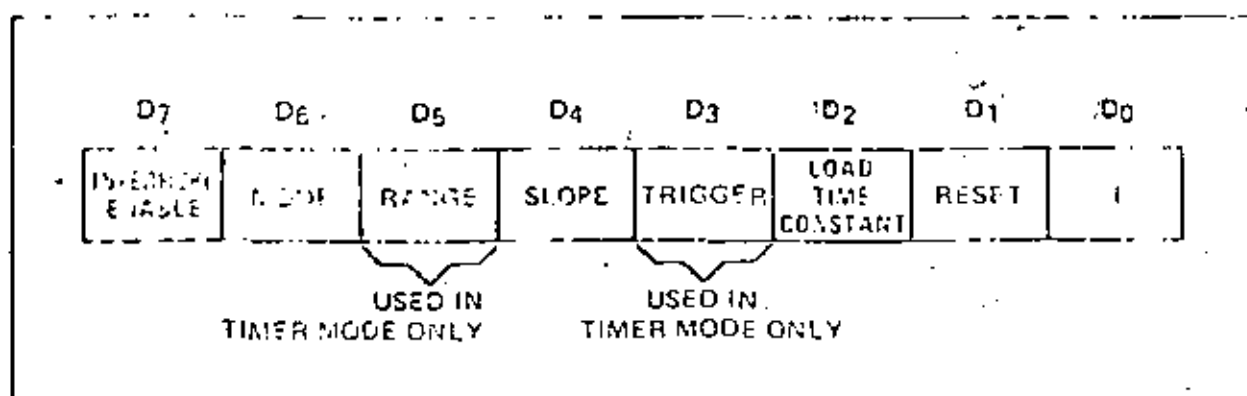
**Bit 4 = 1**

TIMER MODE – positive edge trigger starts timer operation.

COUNTER MODE – positive edge decrements the down counter.

Bit 4 = 0

TIMER MODE – negative edge trigger starts timer operation.

COUNTER MODE – negative edge decrements the down counter.

Bit 3 = 1

Timer Mode Only – External trigger is valid for starting timer operation after rising edge of T_2 of the machine cycle following the one that loads the time constant. The Prescaler is decremented 2 clock cycles later if the setup time is met, otherwise 3 clock cycles.

Bit 3 = 0

Timer Mode Only – Timer begins operation on the rising edge of T_2 of the machine cycle following the one that loads the time constant.

Bit 2 = 1

The time constant data word for the Time Constant Register will be the next word written to this channel. If an updated Channel Control Word and time constant data word are written to a channel while it is already in operation, the Down Counter will continue decrementing to zero before the new time constant is loaded into it.

Bit 2 = 0

No time constant data word for the Time Constant Register should be expected to follow. To program bit 2 to this state implies that this Channel Control Word is intended to update the status of a channel already in operation. Once a channel will not operate without a correctly programmed data word in the Time Constant Register, and a valid bit 2 in this Channel Control Word provides the only way of writing to the Time Constant Register.

Bit 1 = 1

TR – timer and counter stop condition pending. This is not a stored condition. Upon writing into this bit a reset will discontinue current channel operation, however, none of the bits in the channel control register are changed. If bit 2 = 1 and bit 1 = 1 the channel will resume operation upon loading a time constant.

Bit 1 = 0

Channel continues current operation.

52. LOADING THE TIME CONSTANT REGISTER

A channel may not begin operation in either Trigger Mode or Counter Mode unless a time constant data word is written into the Time Constant Register by the CPU. This data word will be expected in the next I/O Write to this channel following the I/O Write of the Channel Control Word, provided that bit 2 of the Channel Control Word is set. The time constant data word may be any integer value in the range 00 to FF. If eight bits in this word are zero, it is interpreted as 256. If a time constant data word is loaded in a channel already in operation, the Down Counter will continue decrementing to zero before the new time constant is loaded from the Time Constant Register to the Down Counter.

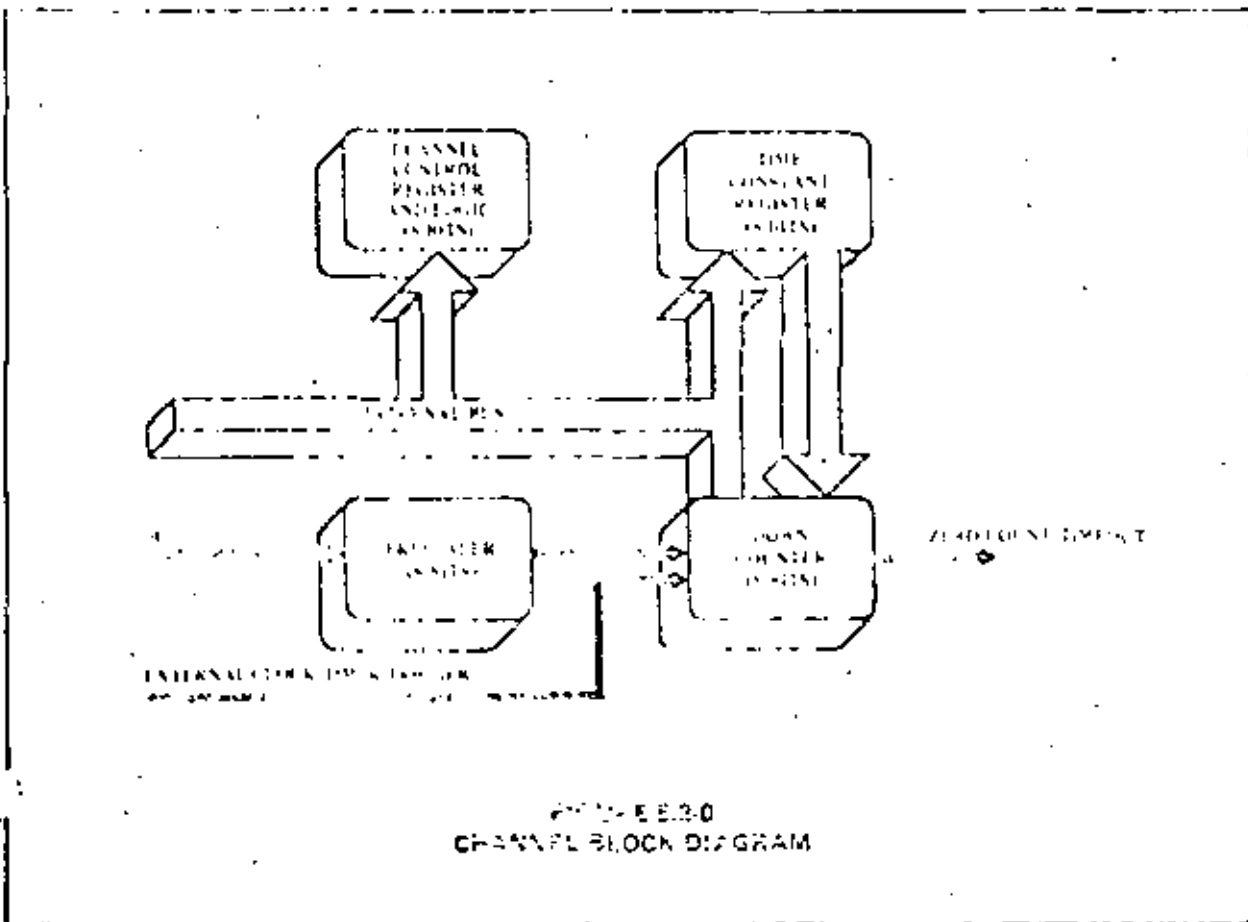
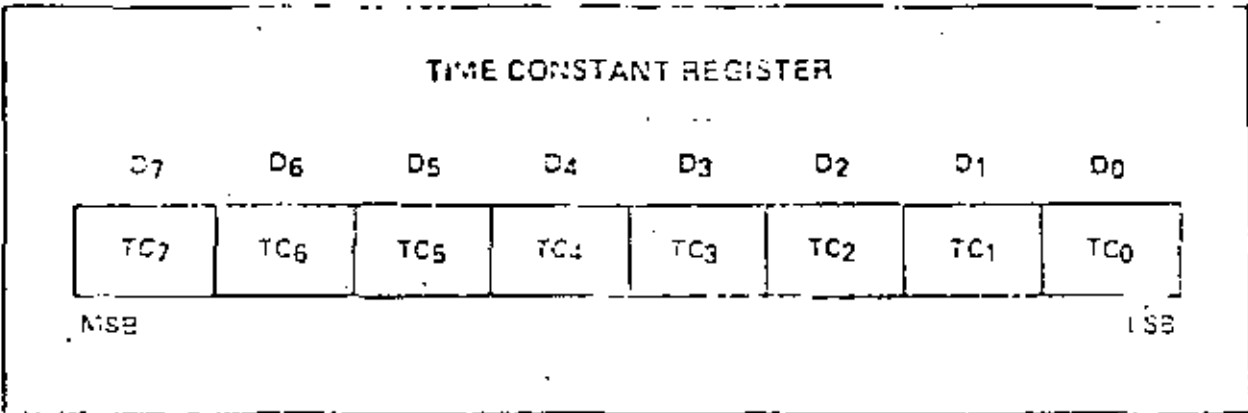

5.3 LOADING THE INTERRUPT VECTOR REGISTER

The Z80 CTC has been designed to operate with the Z80 CPU program and for mode 2 interrupt operation. Under the requirements of this mode, when a CTC channel requires an interrupt and is acknowledged, a 16-bit pointer must be formed to address a code-pending interrupt service routine starting address from a table in memory. The upper 8 bits of this pointer are provided by the CPU's I register, and the lower 8 bits of the pointer are provided by the CTC in the form of an Interrupt Vector unique to the particular channel that requires the interrupt. (For further details, see section 3.0: "CTC Interrupt Servicing".)

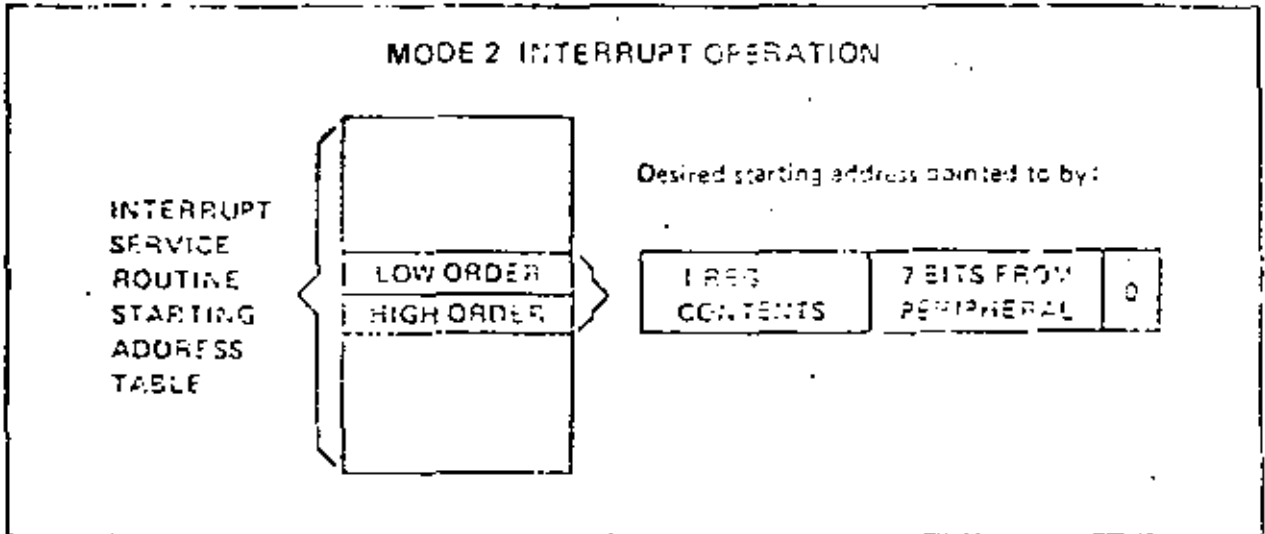

The high-order 8 bits of this Interrupt Vector must be written to the CPU in advance as part of the initial program loading sequence. To do so, the CPU must write the 16-bit word address corresponding to the CTC channel 0 just as if a Channel Control Word were being written to that channel except that bit 0 of the word being written must contain a 0. (As explained above in section 5.1, a bit 0 of a word written to a channel word set to 1, the word would be interpreted as a Channel Control Word, and a 0 in bit 0 signals the CTC to load the incoming word into the Interrupt Vector Register.) Bits 1 and 0, however, are not used in loading this vector. At the time when the interrupting channel must place the Interrupt Vector on the CPU Data Bus, the Interrupt Control Logic of the CTC automatically supplies a binary code in bits 1 and 0 identifying which of the four CTC channels is to be serviced.

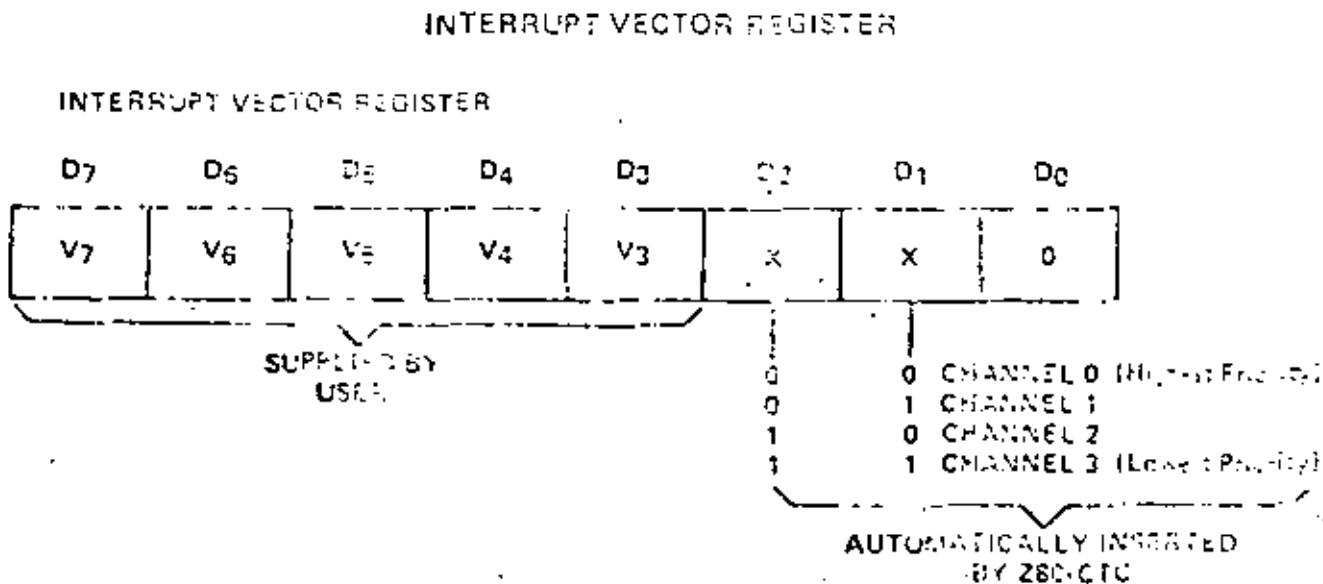

6.0 CTC TIMING

This section illustrates the timing relationship of the relevant CTC pins for the following types of operation: writing a word to the CTC, reading a word from the CTC, counting, and timing. Elsewhere in this manual may be found timing diagrams relating to interrupt servicing (section 7.0), and an A.C. Timing Diagram which quantitatively specifies the timing relationships (section 5.4).

6.1 CTC WRITE CYCLE

Figure 6.0-1 illustrates the timing associated with the CTC Write Cycle. This sequence is applicable to loading either a Channel Control Word, an Interrupt Vector, or a time constant data word.

In the sequence shown, during clock cycle T_1 , the Z80-CPU prepares for the Write Cycle with a false (high) signal at CTC input pin \overline{RD} (Read). Since the CTC has no separate Write signal input, it generates its own internally from the false \overline{RD} input. Later, during clock cycle T_2 , the Z80-CPU initiates the Write Cycle with true (low) signals at CTC input pins \overline{IORQ} (I/O Request) and \overline{CE} (Chip Enable). (Note: \overline{MI} must be false to distinguish the cycle from an interrupt acknowledge.) Also at this time a 2-bit binary code appears at CTC inputs $CS1$ and $CS0$ (Channel Select 1 and 0), specifying which of the four CTC channels is being written to, and the word being written appears on the Z80 Data Bus. Now everything is ready for the word to be latched into the appropriate CTC internal register in synchronization with the rising edge beginning clock cycle T_3 . No additional wait states are allowed.

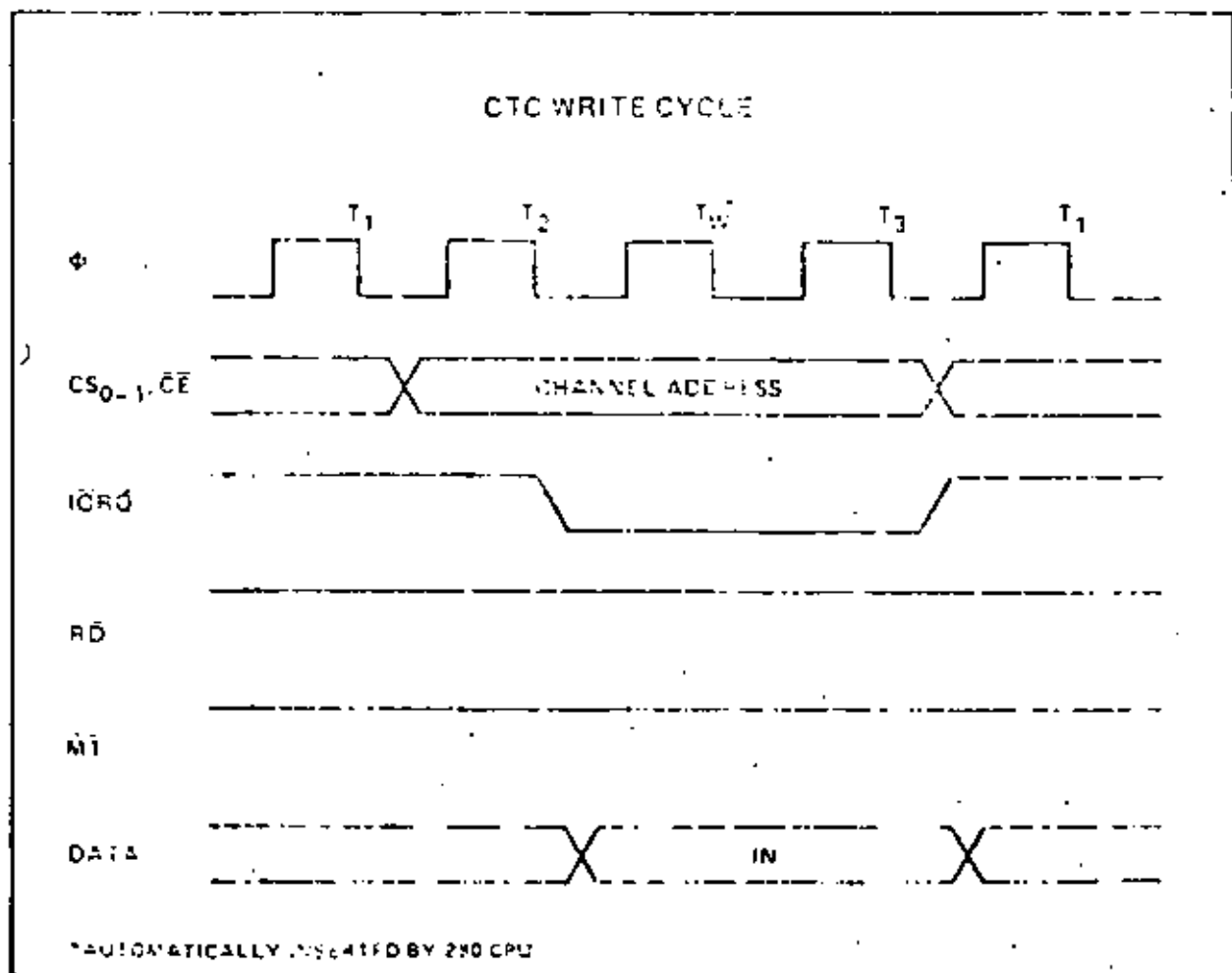

6.2 CPU READ CYCLE

Figure 6-0-2 illustrates the timing associated with the CTC Read Cycle. This sequence is used any time the CPU reads the current contents of the Down Counter. During clock cycle T_1 , the Z80 CPU initiates the Read Cycle with true signals at input pins RD (Read), IORQ (IO Request), and CE (Chip Enable). Also at this time a 2-bit binary code appears at CTC inputs CS1 and CS0 (Channel Select 1 and 0), specifying which of the four CTC channels is being read from. Note: All must be true to distinguish the cycle from an interrupt acknowledge (\bar{INT}). On the rising edge of the cycle T_3 the valid contents of the Down Counter as of the rising edge of cycle T_1 will be available on the Zero (Z) to Bit 7. No additional wait states are allowed.

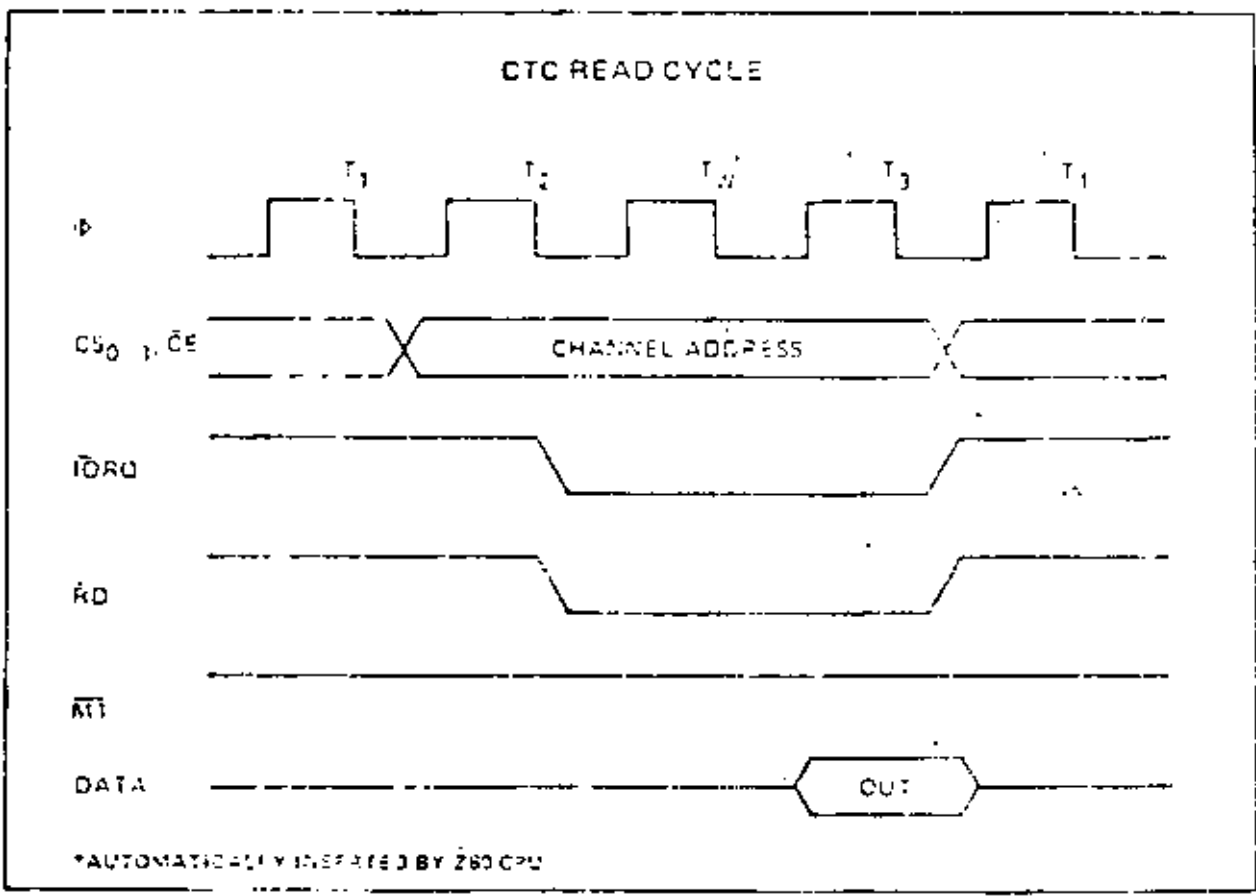

6.3 CTC COUNTING AND TIMING

Figure 6.0-3 illustrates the timing diagram for the CTC Counting and Timing Modes.

In the Counter Mode, the edge (rising edge in this example) from the internal hardware connected to pin CLK/TRG decrements the Down Counter in synchronization with the System Clock (Φ). As specified in the A.C. Characteristics (Section 9) this CLK/TRG pulse must have a minimum width and the minimum period must not be less than twice the system clock period. Although there is no set up time requirement between the active edge of the CLK/TRG and the rising edge of Φ if the CLK/TRG edge occurs closer than a specified minimum time, the decrement of the Down Counter will be delayed one cycle of Φ immediately after the decrement of the Down Counter. 1 to 0, the ZC/TO output is pulsed true.

In the Timer Mode, a pulse trigger (user-selectable as either active high or active low) at the CLK/TRG pin enables timing function on the second succeeding rising edge of Φ . As in the Counter Mode, the triggering pulse is delayed synchronously and must have a minimum width. The timing function is initiated in synchronization with Φ , and a minimum set up time is required between the active edge of the CLK/TRG and the next rising edge of Φ . If the CLK/TRG edge occurs closer than this, the initiation of the timer function will be delayed one cycle of Φ .

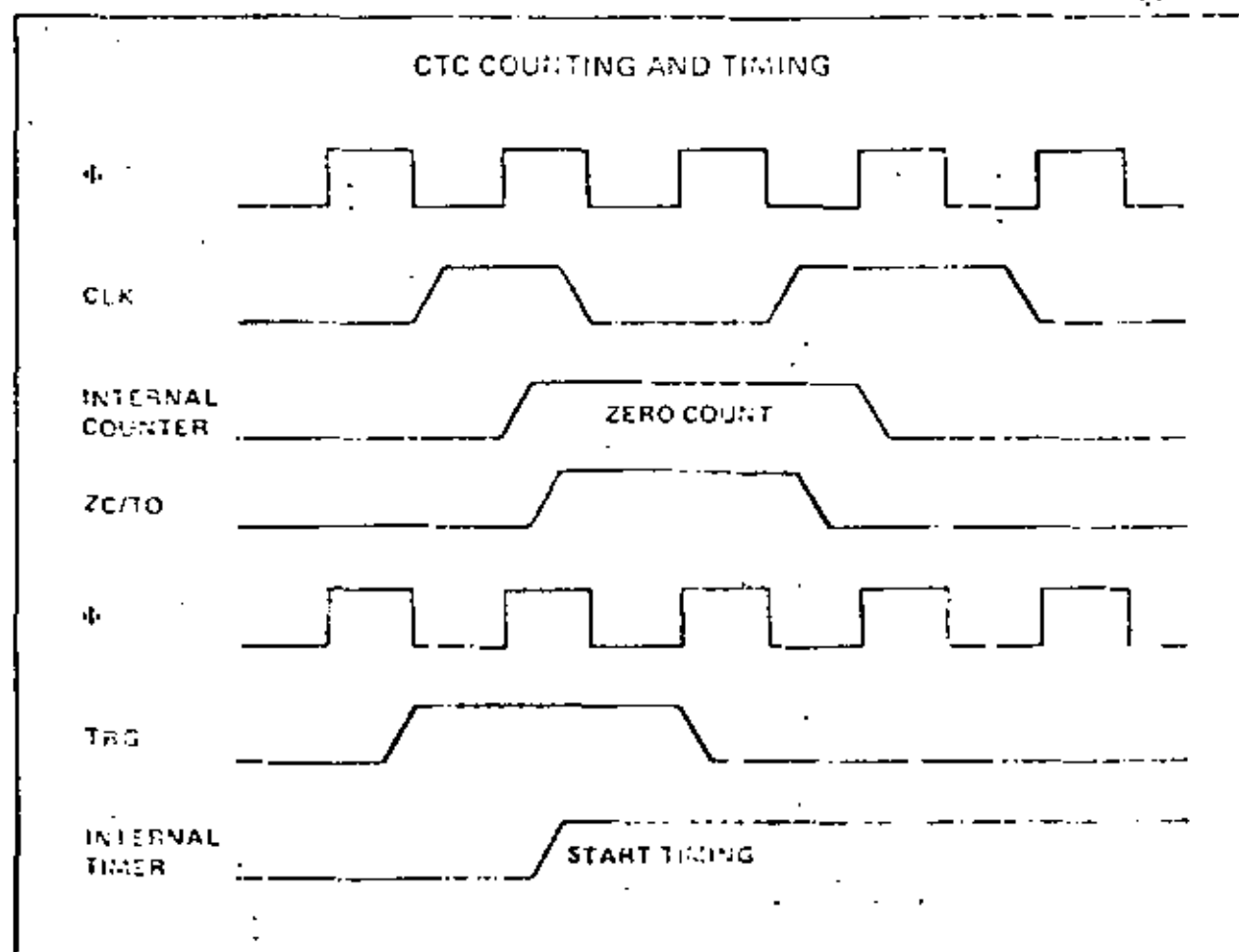

7.0 CTC INTERRUPT SERVICING

Each CTC channel may be individually programmed to request an interrupt every time its Down Counter reaches a count of zero. The purpose of a CTC-generated interrupt, as for any other peripheral device, is to force the CPU to execute an interrupt service routine. To utilize this feature the Z80 CPU must be programmed for mode 2 interrupt response. Under the requirements of this mode, when a CTC channel requests an interrupt and is acknowledged, a 16-bit pointer must be formed to obtain a corresponding interrupt service routine starting address from a table in memory. The lower 5 bits of the pointer are provided by the CTC in the form of an Interrupt Vector unique to the particular channel that requested the interrupt. (For further details, refer to chapter 5.0 of the Z80 CPU Technical Manual.)

The CTC's Interrupt Control Logic insures that it acts in accordance with Z80 system interrupt protocol for nested priority interrupt and proper return from interrupt. The priority of any system device is determined by its physical location in a daisy chain configuration. Two signal lines (IEI and IEO) are provided in the CTC and all Z80 peripheral devices to form the system daisy chain. The device closest to the CPU has the highest priority; within the CTC, interrupt priority is predetermined by channel number, with channel 0 having the highest priority. According to Z80 system interrupt protocol, low priority devices or channels may not interrupt higher priority devices or channels that have already interrupted and not had their interrupt service routines completed. However, high priority devices or channels may interrupt the servicing of lower priority devices or channels. (For further details, see section 2.3, "Interrupt Control Logic".)

Sections 7.1 and 7.2 below describe the nominal timing relationships of the relevant CTC pins during an Interrupt Acknowledge Cycle and the Return from Interrupt Cycle. Section 7.3 below discusses a typical example of daisy chain interrupt servicing.

7.1 INTERRUPT ACKNOWLEDGE CYCLE

Figure 7.0.1 illustrates the timing associated with the Interrupt Acknowledge Cycle. Some time after an interrupt is requested by the CTC, the CPU will send out an interrupt acknowledge (\overline{ACK} and \overline{IOR}). To insure that the daisy chain enable lines stabilize, channels are inhibited from changing state into wait states, status when \overline{MI} is active. \overline{MI} is active about two clock cycles earlier than \overline{IOR} , and \overline{RD} is false to destroy the cycle from an instruction fetch. During this time the interrupt logic of the CTC will determine the highest priority channel requesting an interrupt. If the CTC Interrupt Enable Input (IEI) is active, then the highest priority interrupting channel within the CTC places its Interrupt Vector onto the Data Bus when \overline{IOR} goes active. Two wait states (T_{W^*}) are automatically inserted at this time to allow the daisy chain to stabilize. Additional wait states may be added.

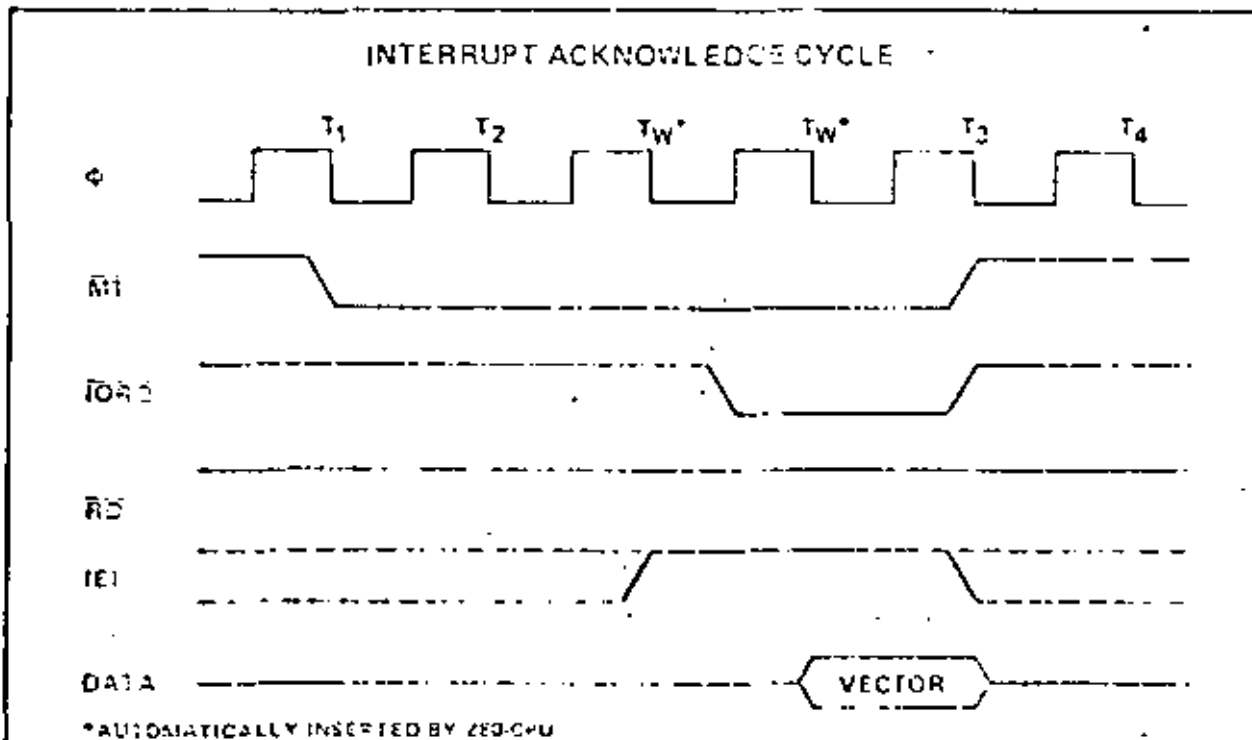

7.2 RETURN FROM INTERRUPT CYCLE

Figure 7-0-2 illustrates the timing associated with the RETI instruction. This instruction is used at the end of an interrupt service routine to initialize the daisy chain enable lines for proper control of nested priority interrupt handling. The C IC decodes the two-byte RETI code internally and determines whether it is intended for a channel being serviced.

When several Z80 peripheral chips are in the daisy chain IEO will become active on the chip currently under service when an EDH opcode is decoded. If the following opcode is 4DH, the peripheral being serviced will be re-initialized and IEO will become active. Additional wait states are allowed.

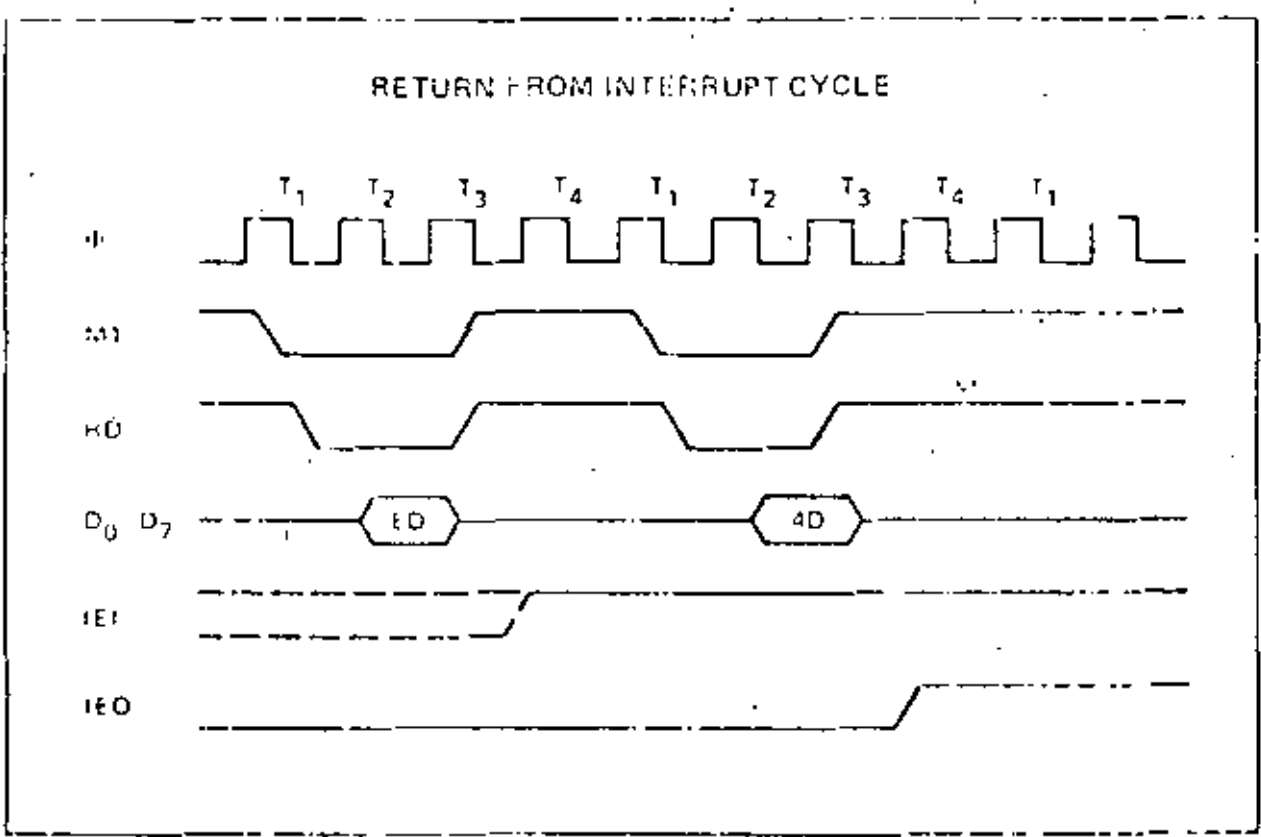

7.3 DAISY CHAIN INTERRUPT SERVICING

Figure 7.01 illustrates a typical nested interrupt sequence which may occur in the CPU. In this example channel 2 interrupts and is granted service. While this channel is being serviced, higher priority channel 1 interrupts and is granted service. The service routine for the higher priority channel is completed, and a RETI instruction (see section 7.2 for further details) is executed to signal the channel that its routine is complete. At this time, the service routine of the lower priority channel 2 is resumed and completed.

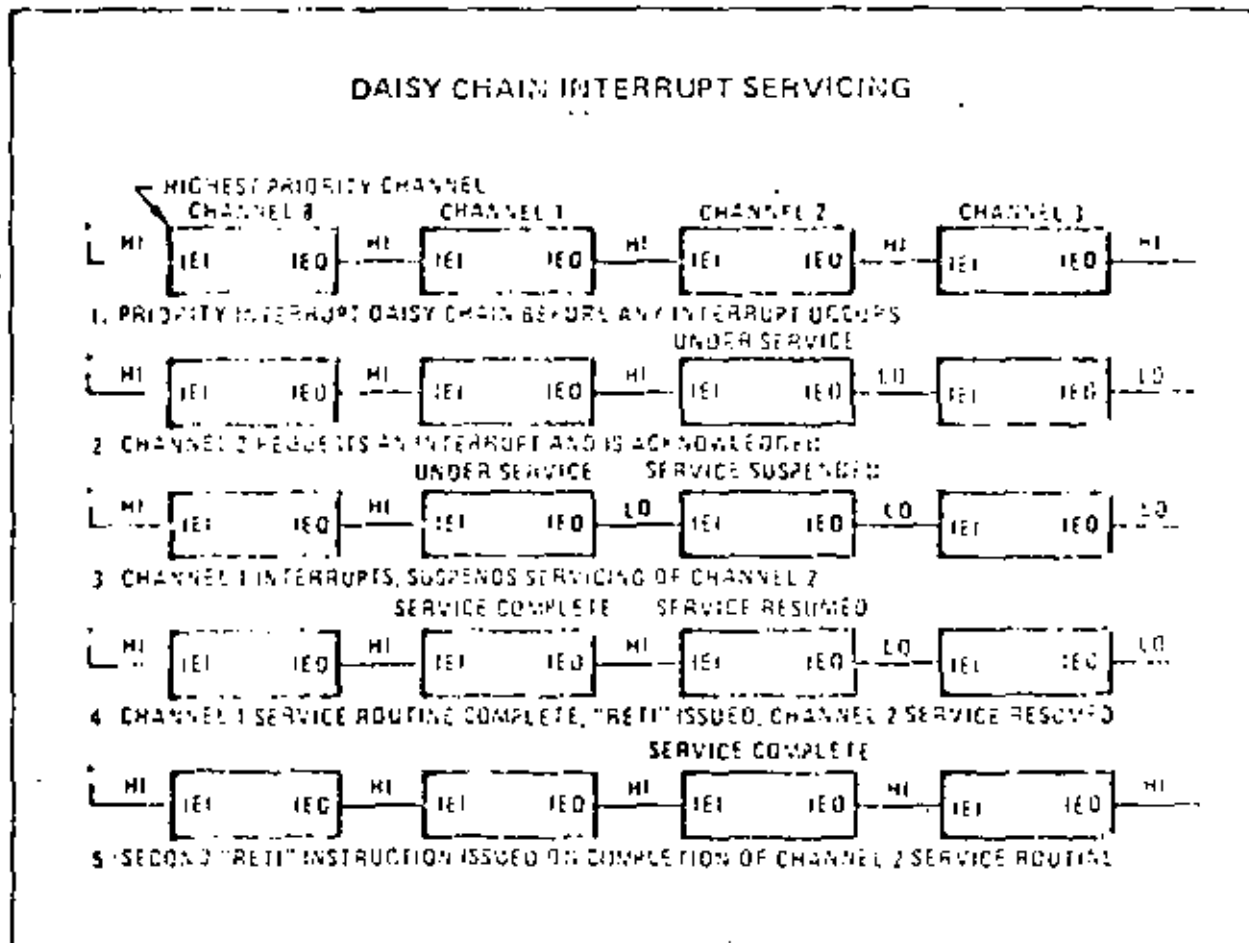

8.0 ABSOLUTE MAXIMUM RATINGS

145

Stress	0°C to 10°C	10°C to 70°C	Comment
Supply Voltage	0°C to 10°C	10°C to 70°C	Stresses above those listed under "Absolute Maximum Rating" may cause permanent damage to the device. This is a stress rating only and for normal operation of the device at these or any other conditions above those indicated in the operating sections of this specification is not implied. Exposure to stressful maximum operating conditions for extended periods may affect device reliability.
Storage Temperature	-65°C to +150°C		
Voltage On Any Pin With Respect To Ground	-0.3 V to +2 V		
Power Dissipation	0.8 W		

8.1 D.C. CHARACTERISTICS

TA = 0°C to 70°C, VCC = 5V ± 5% unless otherwise specified

280-CTC

Symbol	Parameter	Min	Max	Unit	Test Condition
V _{ILC}	Clock Input Low Voltage	-0.3	45	V	I _{OL} = 2 mA I _{OH} = -250 μA T _C = 200 nsec V _{IN} = 0 to V _{CC} V _{OUT} = 2.4 to V _{CC} V _{OUT} = 0.4V V _{OH} = 1.5V R _{EXT} = 390Ω
V _{IHC}	Clock Input High Voltage (1)	V _{CC} - 6	V _{CC} + 3	V	
V _{IL}	Input Low Voltage	-0.3	0.8	V	
V _{IH}	Input High Voltage	2.0	V _{CC}	V	
V _{OL}	Output Low Voltage		0.4	V	
V _{OH}	Output High Voltage	2.4		V	
I _{CC}	Power Supply Current		120	mA	
I _{II}	Input Leakage Current		10	μA	
I _{LOH}	Tri State Output Leakage Current in Float		10	μA	
I _{LOL}	Tri State Output Leakage Current in Float		-10	μA	
I _{OND}	Darlington Drive Current	-1.5		mA	

299A-CTC

Symbol	Parameter	Min	Max	Unit	Test Condition
V _{ILC}	Clock Input Low Voltage	-0.3	45	V	I _{OL} = 2 mA I _{OH} = -250 μA T _C = 250 nsec V _{IN} = 0 to V _{CC} V _{OUT} = 2.4 to V _{CC} V _{OUT} = 0.4V V _{OH} = 1.5V R _{EXT} = 390Ω
V _{IHC}	Clock Input High Voltage (1)	V _{CC} - 6	V _{CC} + 3	V	
V _{IL}	Input Low Voltage	-0.3	0.8	V	
V _{IH}	Input High Voltage	2.0	V _{CC}	V	
V _{OL}	Output Low Voltage		0.4	V	
V _{OH}	Output High Voltage	2.4		V	
I _{CC}	Power Supply Current		120	mA	
I _{II}	Input Leakage Current		10	μA	
I _{LOH}	Tri State Output Leakage Current in Float		10	μA	
I _{LOL}	Tri State Output Leakage Current in Float		-10	μA	
I _{OND}	Darlington Drive Current	-1.5		mA	

8.2 CAPACITANCE

TA = 25°C, f = 1 MHz

Symbol	Parameter	Max	Unit	Test Condition
C ₀	Clock Capacitance	20	pF	Unmeasured Pins Returned to Ground
C _{IN}	Input Capacitance	5	pF	
C _{OUT}	Output Capacitance	10	pF	

TA = 0°C to 70°C, VCC = +5 V ± 5%, unless otherwise noted

Symbol	Symbol	Parameter	Min	Max	Unit	Com.
φ	t _C	Clock Period	400	1T ₁	ns	
	t _{WPH}	Clock Pulse Width, Clock High	170	2000	ns	
	t _{WPL}	Clock Pulse Width, Clock Low	170	2000	ns	
	t _r , t _f	Clock Rise and Fall Times		30	ns	
	t _H	Any Hold Time for Specified Setup Time	0		ns	
CS, \overline{CE} , etc.	t _S (CS)	Control Signal Setup Time to Rising Edge of φ During Read or Write Cycle	160		ns	
D _Q , D _I	t _{DR} (D)	Data Output Delay from Rising Edge of RD During Read Cycle		480	ns	[2]
	t _S (D)	Data Setup Time to Rising Edge of φ During Write or \overline{MEM} Cycle	60		ns	
	t _{DI} (D)	Data Input Delay from Falling Edge of IORQ During I/OA Cycle		340	ns	[2]
	t _{FO}	Delay to Floating Bus (Output Buffer Disable Time)		230	ns	
I/O	t _S (I/O)	I/O Setup Time to Falling Edge of IORQ During I/OA Cycle	200		ns	
	t _{DI} (IO)	I/O Delay Time from Rising Edge of IEO		220	ns	[3]
	t _{FO} (IO)	I/O Delay Time from Falling Edge of IEO		190	ns	[2]
IORQ	t _{DI} (IO)	I/O Delay Time from Falling Edge of \overline{MEM} (Whenever Occurring just Prior to I/O)		300	ns	[3]
	t _S (IR)	IORQ Setup Time to Rising Edge of φ During Read or Write Cycle	250		ns	
	t _S (MR)	\overline{MEM} Setup Time to Rising Edge of φ During I/OA or \overline{MEM} Cycle	210		ns	
RD	t _S (RD)	RD Setup Time to Rising Edge of φ During Read or \overline{MEM} Cycle	240		ns	
CNT	t _{DT} (NT)	INT Delay Time from Rising Edge of CLK, TRG		2t _C (H) + 200		Counter 1, Timer 1
	t _{DT} (T)	INT Delay Time from Rising Edge of φ		t _C (H) + 200		Counter 2
	t _C (C)	Clock Period	2t _C (H)			Counter 1, Timer 1
	t _r , t _f	Clock and Trigger Rise and Fall Times		50		Counter 1, Timer 1
	t _S (CK)	Clock Setup Time to Rising Edge of φ for Immediate Count	210			Counter 1, Timer 1
	t _S (TR)	Trigger Setup Time to Rising Edge of φ for Enabling of Prescaler on Following Rising Edge of φ	210			Counter 1, Timer 1
	t _W (CTH)	Clock and Trigger High Pulse Width	200			Counter 1, Timer 1
ZC TO ₀₋₂	t _{OH} (ZC)	ZC/TO Delay Time from Rising Edge of φ, ZC/TO High		190		Counter 1, Timer 1
	t _{OL} (ZC)	ZC/TO Delay Time from Falling Edge of φ, ZC/TO Low		190		Counter 1, Timer 1

- Notes: [1] t_C = WPH + WPL + t_r + t_f
 [2] Increase delay by 10 ns for each 50 pF increase in loading; 200 pF maximum for data lines and 100 pF for control lines.
 [3] Increase delay by 2 ns for each 10 pF increase in load up to 100 pF maximum.
 [4] \overline{RESET} must be active for a minimum of 3 clock cycles.

OUTPUT LOAD CIRCUIT

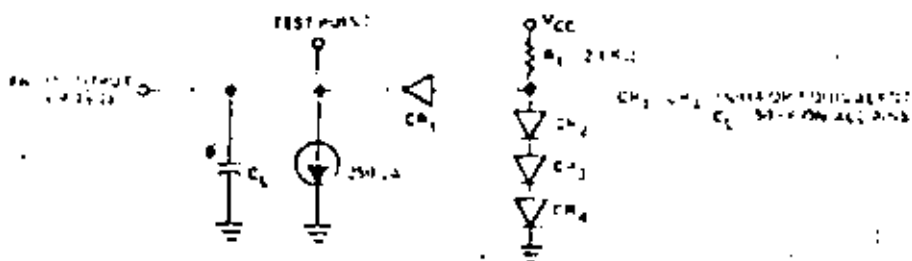

TA = 0°C to 70°C, VCC = 5V ± 5%, unless otherwise noted

Signal	Symbol	Parameter	Min	Max	Unit	Com
φ	t _C	Clock Period	250	(1)	ns	
	t _{WH} (φ)	Clock Pulse Width, Clock High	105	2000	ns	
	t _{WL} (φ)	Clock Pulse Width, Clock Low	105	2000	ns	
	t _{r,φ}	Clock Rise and Fall Times		30	ns	
CS, CE, etc	t _S (CS)	Control Signal Setup Time to Rising Edge of φ During Read or Write Cycle	60		ns	
	t _{OR} (D)	Data Output Delay from Falling Edge of \overline{RD} During Read Cycle		180	ns	(2)
D ₀ -D ₇	t _S (D)	Data Setup Time to Rising Edge of φ During Write or M1 Cycle	50		ns	
	t _O (D)	Data Output Delay from Falling Edge of \overline{WRG} During INTA Cycle		160	ns	(2)
	t _F (D)	Delay to Floating Bus (Output Buffer Disable Time)		110	ns	
IE1	t _S (IE1)	IE1 Setup Time to Falling Edge of \overline{ICRG} During INTA Cycle	140		ns	
IE1	t _{OH} (IE1)	IE1 Delay Time from Rising Edge of IE1		160	ns	(3)
	t _{OL} (IE1)	IE1 Delay Time from Falling Edge of IE1		130	ns	(3)
	t _D (IE1)	IE1 Delay from Falling Edge of \overline{INT} (Interrupt Occurring just Prior to M1)		190	ns	(3)
\overline{IOR}	t _S (\overline{IOR})	\overline{IOR} Setup Time to Rising Edge of φ During Read or Write Cycle	115		ns	
M1	t _S (M1)	M1 Setup Time to Rising Edge of φ During INTA or M1 Cycle	90		ns	
\overline{RD}	t _S (\overline{RD})	\overline{RD} Setup Time to Rising Edge of φ During Read or M1 Cycle	115		ns	
INT	t _{ON} (INT)	INT Delay Time from Rising Edge of CLK+TRG		Zigzag = 140		Counter Mode
	t _{OFF} (INT)	INT Delay Time from Rising Edge of φ		t _{OFF} = 140		Timer Mode
CLK, TAG ₀₋₃	t _C (CLK)	Clock Period	Zigzag			Counter Mode
	t _{r,φ}	Clock and Trigger Rise and Fall Times		30		
	t _S (CLK)	Clock Setup Time to Rising Edge of φ for Immediate Count	130			Counter Mode
	t _S (TR)	Trigger Setup Time to Rising Edge of φ for enabling of Prescaler on Following Rising Edge of φ	130			Timer Mode
	t _W (CLK)	Clock and Trigger High Pulse Width	120			Counter and Timer Mode
ZC(10-3)	t _{OH} (ZC)	ZC/TO Delay Time from Rising Edge of φ, ZC/TO High		120		Counter and Timer Mode
	t _{OL} (ZC)	ZC/TO Delay Time from Rising Edge of φ, ZC/TO Low		120		Counter and Timer Mode

- Note: (1) t_C = t_{WH}(φ) + t_{WL}(φ) + t_{r,φ}
 (2) Increase delay by 10 ns for each 50 pF increase in loading, 200 pF maximum for data lines and 100 pF for control lines.
 (3) Increase delay by 3 ns for each 10 pF increase in loading, 100 pF maximum.
 (4) RESET must be active for a minimum of 3 clock cycles.

OUTPUT LOAD CIRCUIT

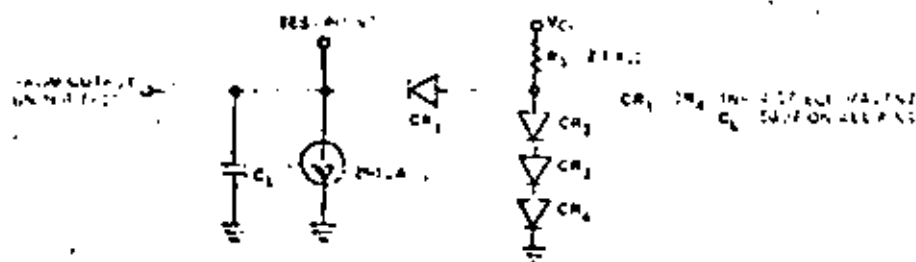

8.6 PACKAGE CONFIGURATION

PACKAGE OUTLINE

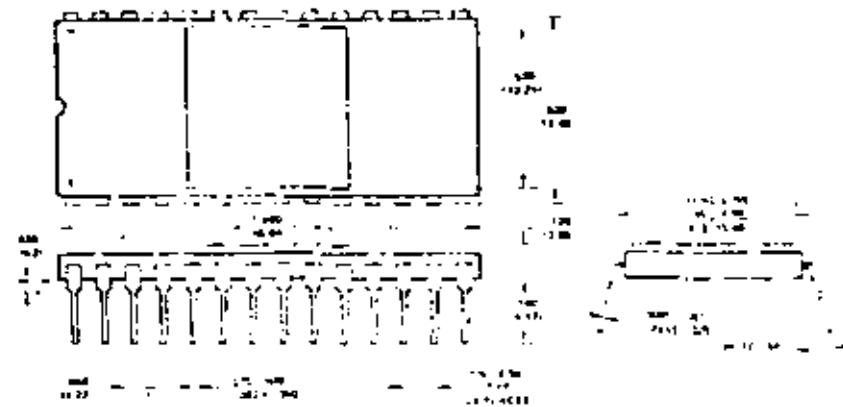
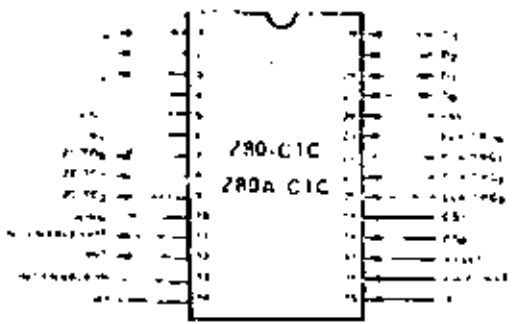

Ordering Information

- C Ceramic
- P Plastic
- S Standard 5V: 0° to 70°C
- E Extended 5V: 30° to 85°C
- M Military 5V: 100° to 125°C

Example:

- Z80-CIC CS (Ceramic Standard Range)
- Z80A-CIC PS (Plastic Standard Range, 2 MHz)

ZILOG Z80 MICROCOMPUTER SYSTEM COMPONENT FAMILY

- Z80, Z80A-CPU CENTRAL PROCESSOR UNIT
- Z80, Z80A-PIO PARALLEL I/O
- Z80, Z80A-CTC COUNTER/TIMER CIRCUIT
- Z80, Z80A-DMA DIRECT MEMORY ACCESS
- Z80, Z80A-SIO SERIAL I/O
- Z6104 4K x 1 STATIC RAM
- Z6116 16K x 1 DYNAMIC RAM

● Z - 80 MBC

● SBC

THIS PAGE INTENTIONALLY LEFT BLANK.

Z80[®]-MCB Microcomputer Board

Product Specification APRIL 1978

The Z80-MCB Microcomputer Board is a complete single board computer with its own self-contained memory plus serial and parallel I/O ports. It features the use of the Z80-CPU, Z80-CTC, Z80-PIO, and Z-6116 devices that have become standard components in the microcomputer industry.

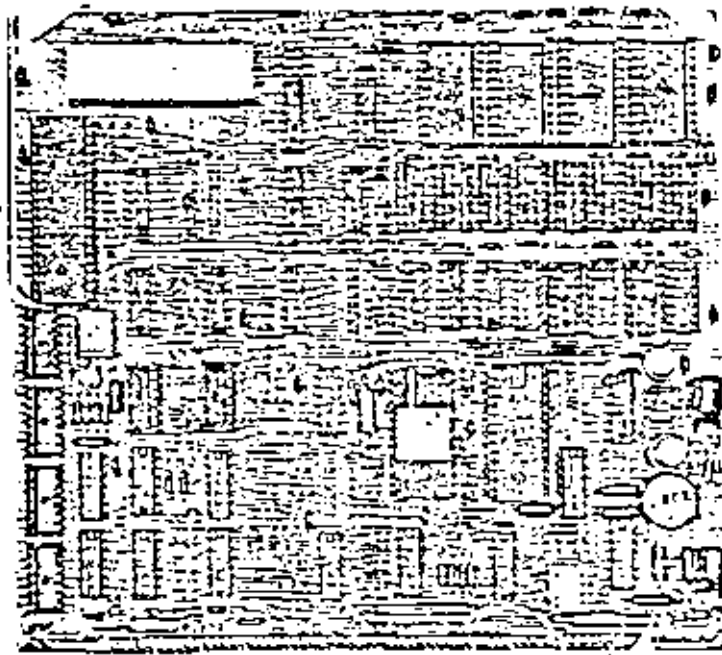
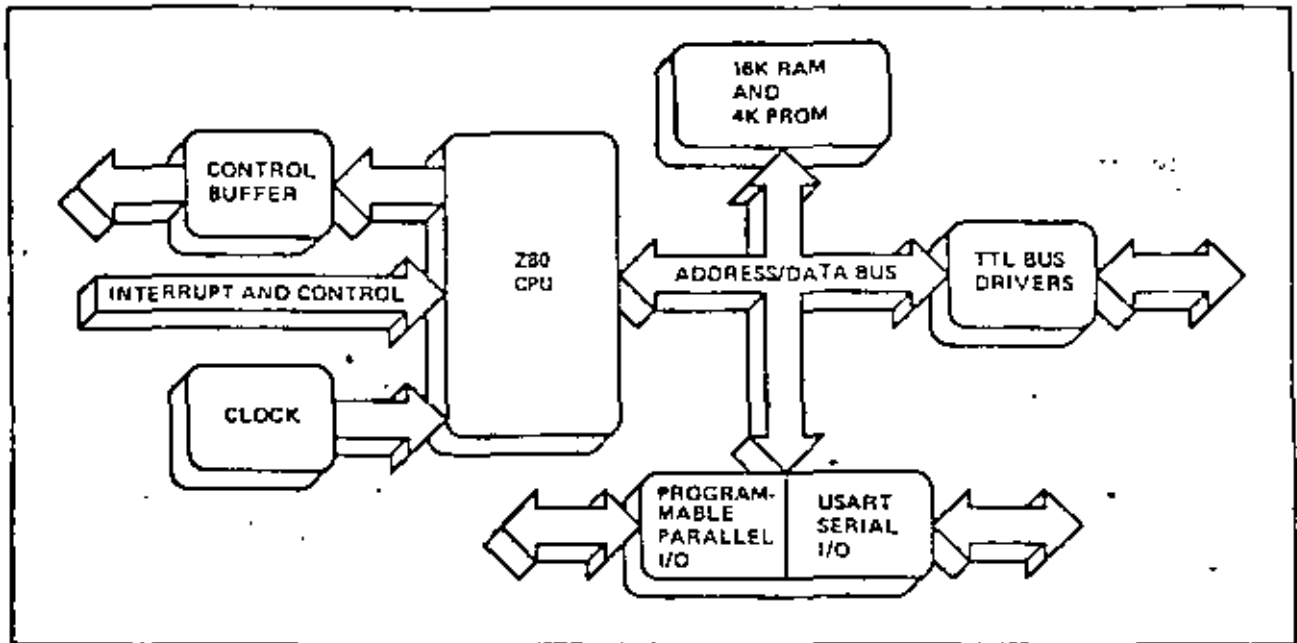

Description

The Z80-Microcomputer Board (MCB) is a modular, single-board computer. It is designed around the Zilog Z80-CPU and employs an on-board DC converter to allow operation from a single +5 volt power supply. This board is highly flexible, and can be customized by the user for specific applications.

The basic configuration consists of the Z80-CPU, 16K bytes of dynamic RAM, provision for up to 4K bytes of PROM, ROM, or EPROM, both parallel and serial I/O ports, I/O port decoders, and a crystal controlled clock. The parallel port is implemented with the Z80-PIO with

area reserved for user-applied driver and/or receiver logic. One of the four timers in the Z80-CTC is used as a baud rate generator for the serial interface implemented with an 8251 USART. Strapping options are available for selecting several memory and I/O port configurations, terminal interface schemes, and operating modes. Expansion of the card is made possible by feeding all buffered address, data, and control lines to a 100-pin edge connector. Two versions of monitor software (1K and 3K bytes) are available in bipolar PROMs for insertion into the four 24-pin PROM sockets, allowing software debugging and terminal interface (TTY, CRT, or disk).

Features

- Z80-CPU single-chip n-channel processor with 158 instructions (including all of the 8080A's 78 instructions with total software compatibility). New instructions include memory-to-memory block transfers, I/O block transfers, 16-bit arithmetic, 9 types of rotates and shifts, bit manipulation and many new addressing modes. (See *Z80-CPU Product Specification* for specific details.)
- 16K or 4K bytes of high-speed, low-power dynamic RAM.
- MOS EPROM, fuseable bipolar PROM or masked ROM for user's program storage. Zilog monitor software is available in 1K, and 3K byte versions.
- Two memory page decoders which select 16K dynamic RAM or 4K bytes of ROM. Strapping options can relocate these memories into any segment of the 64K address space.
- Programmable full duplex serial I/O port with RS-232 or current-loop interface. Can be programmed to operate at 14 separate baud rates from 50 baud to 38.4K baud. Can operate using any asynchronous or synchronous protocol.
- Modem control signals including Request To Send and Clear To Send are provided with the RS-232 interface.
- A separate reader control line is available for teletype terminals not equipped with automatic reader control.
- Universal parallel I/O can be programmed to define any direction and data-transfer characteristics for two 8-bit ports. Full flexibility in buffering and terminating the parallel ports is provided by uncommitted driver/termination device locations. Data transfer can be accomplished under full interrupt control. (See *Z80-PIO Product Specification* for specific details.)
- Z80-CTC includes four programmable counter/timer circuit channels. It is used as the programmable baud rate generator; additional channels can be used as real-time clocks. (See *Z80-CTC Product Specification* for specific details.)
- Switches on the board can be read by the CPU for various options. The software provided in the standard 1K byte monitor can read these switches and set the communication frequency to any of 14 common rates by programming the CTC. Switches can also be used for other similar functions.
- Board contains I/O port address decoders which can decode 32 unique contiguous port addresses. Several of these are used to select the channels of the USART, PIO and CTC. Additional decoded port select signals are available for various peripherals attached to the system.
- 19.6608MHz crystal oscillator divided to 2.457MHz for Z80-CPU operation and dividable by Z80-CTC to provide the serial I/O baud rates or any other desired system frequencies.
- Bus drivers are provided for memory and I/O expansion to other boards that are a part of the series.
- 1K byte monitor software has terminal handler, load and punch routines as well as set and display memory commands. A Go command begins execution of user programs. There are debug aids such as set and display registers and breakpoints. The 3K byte version includes a floppy disk controller and even more debug capacity.
- Tri-state buffers on all data, address and control lines.
- One nonmaskable and three maskable interrupts.

MCB Applications

The Z80-MCB can be used in many applications traditionally not available to single microcomputer boards. Many of the functions previously performed by external hardware are now implemented in the Z80-CPU and peripherals. The performance per unit board area has been greatly optimized, thus eliminating the need for extra cards, card cages, back planes, and connectors for many applications. The Z80-MCB can be used for machine controllers, customized small business computers, automated test stands, customized data acquisition systems, process control systems, communications or display controllers, multiprocessor systems, and word processing systems, just to name a few. The diagram below shows the Z80-MCB used with the Zilog Video Display Board to configure an intelligent terminal.

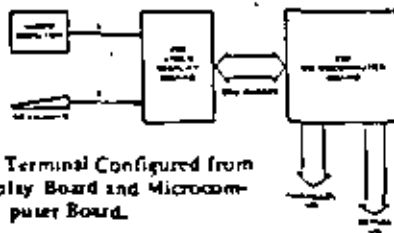

Intelligent Terminal Configured from Video Display Board and Microcomputer Board.

Specifications

POWER SUPPLY:	+5V DC \pm 5%, current: 2 amps max (with 3 PROMs)
CONNECTOR:	122-pin edge (100 mil spacing) Augat PN 14005-19P1
SIZE:	Length, 7.7" Depth, 7.5" Spacing, 0.5" centers
ENVIRONMENTAL:	0° - 50° C temperature range. Up to 90% humidity without condensation.
MEMORY CAPACITY:	4K or 16K bytes dynamic RAM, plus up to 4K bytes PROM, ROM or EPROM. Expandable by use of Z80-RMB 16K RAM board to 64K bytes of main memory.
I/O CHANNELS:	Serial I/O port with RS-232 or 20 mA current loop interface; Two (2) software configurable bidirectional 8-bit parallel I/O ports.

Pin Assignments

MCB - PIN OUT (COMPONENT SIDE)

1	+5	34	I/O SUB GROUP Φ -
2	+5	35	RFSH-
3	+5	36	ADDRESS BUS 13
4	IORQ-	37	ADDRESS BUS 11
5	DATA BUS 5	38	OPEN (Z 21) (PULL UP)
6	20 mA DATA	39	OPEN (Z 20)
7	RECEIVE DATA	40	OPEN (Z 19)
8	DATA BUS 3	41	OPEN (Z 18)
9	MASTER RESET	42	OPEN (Z 17)
10	MASTER RESET-	43	OPEN (Z 16)
11	CLEAR TO SEND	44	OPEN (Z 15)
12	DATA BUS 6	45	OPEN (Z 14)
13	DATA BUS Φ	46	OPEN (Z 13)
14	REQ TO SEND	47	OPEN (Z 12)
15	XMITTED DATA	48	OPEN (Z 11)
16	MEM SEL IN	49	OPEN (Z 10)
17	DISK C/T	50	OPEN (Z 9)
18	C/T 2	51	OPEN (Z 8)
19	20 mA DATA RET	52	OPEN (Z 7)
20	TTY TAPE CNTL RET	53	OPEN (Z 6)
21	MEMORY SEL OUT	54	OPEN (Z 5)
22	INTE IN CTC	55	OPEN (Z 4)
23	WR-	56	OPEN (Z 3)
24	USER STRB 3	57	OPEN (Z 2)
25	DISK STRB	58	OPEN (Z 1)
26	ADDRESS BUS 7	59	+5
27	ADDRESS BUS B	60	+5
28	IOWR-	61	+5
29	ADDRESS BUS 5		
30	ADDRESS BUS 6		
31	RESET-		
32	ADDRESS BUS 15		
33	I/O SUB GROUP 2-		

NOTE: Open pins are definable by user. One is pulled up for use as a source for interrupt enable daisy chain.

MCB - PIN OUT (SOLDER SIDE)

62	GND	93	Φ -
63	GND	94	ADDRESS BUS 14
64	GND	95	I/O SUB GROUP 3-
65	TTY TAPE CNTL	96	I/O SUB GROUP 1-
66	-5V EXTERNAL	97	ADDRESS BUS 12
67	-5V EXTERNAL	98	ADDRESS BUS 4
68	DATA BUS 4	99	Φ -
69	+12V EXTERNAL	100	ADDRESS BUS 3
70	+12V EXTERNAL	101	ADDRESS BUS 2
71	DATA BUS 2	102	ADDRESS BUS 1
72	-12V EXTERNAL	103	ADDRESS BUS Φ
73	DATA BUS 7	104	I/O GROUP Φ -
74	DATA SET READY	105	I/O GROUP 1-
75	DATA BUS 1	106	I/O GROUP 2-
76	DATA TERM. RDY/ XMIT CLK	107	I/O GROUP 3-
77	20mA REC.V. RETN./ REC.V. CLK	108	I/O GROUP 4-
78	SYNC DETECT	109	BUS RQ-
79	INT-	110	NMI-
80	LINE SIGNAL DET.	111	PIO INTE OUT
81	20mA REC.V.	112	SERIAL CLK IN (2XI)
82	USER C/T 3	113	HALT-
83	ROM SEL OUT	114	INTE IN PIO
84	USER RTC C/T	115	M 1-
85	MRQ-	116	RD-
86	CTC INTE OUT	117	INTE IN SER
87	2X SERIAL CLK	118	Φ
88	BUSAK-	119	WAIT-
89	ADDRESS BUS 9	120	GND
90	IORD-	121	GND
91	ADDRESS BUS 10	122	GND
92	OM SEL IN-		

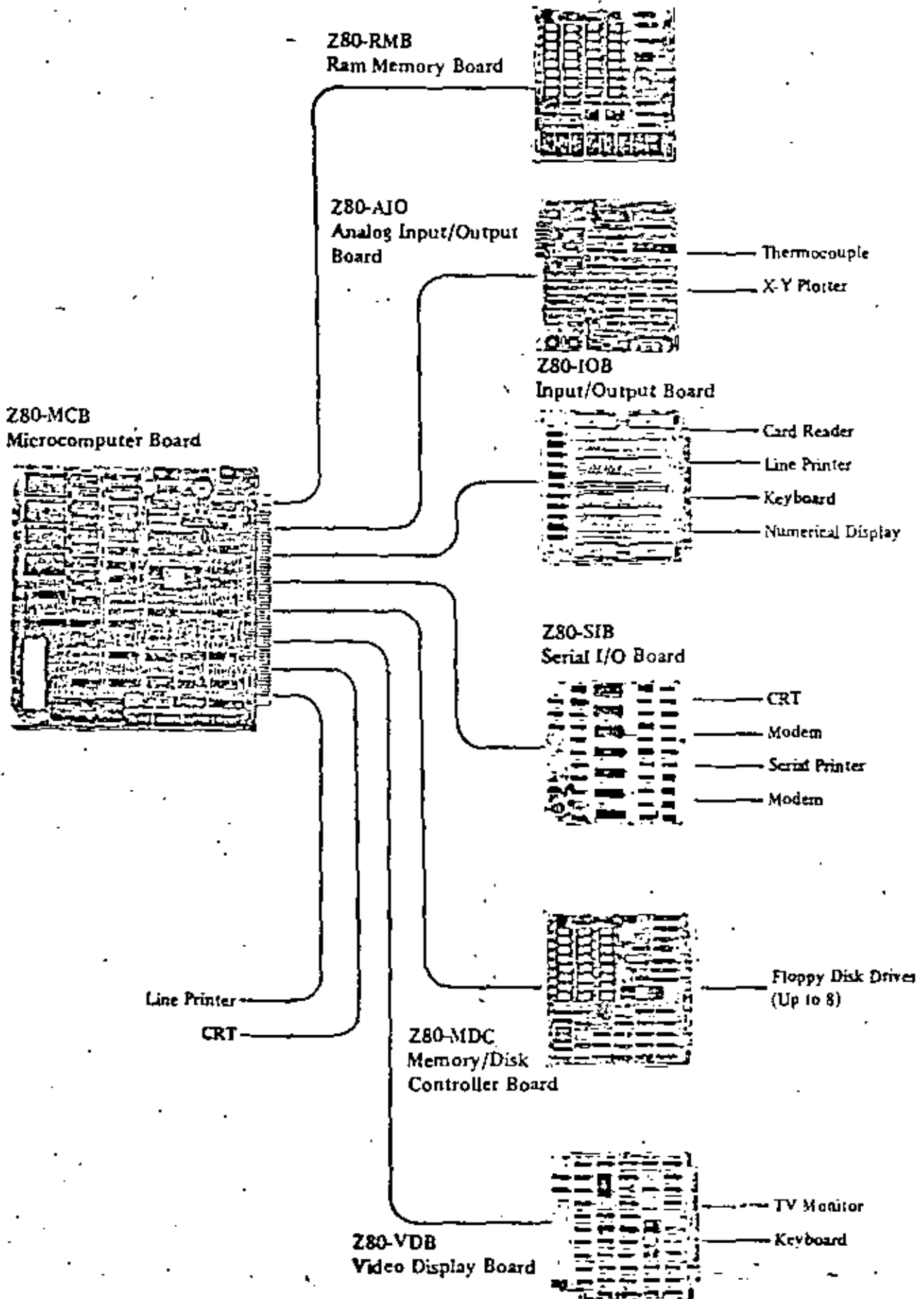

THIS PAGE INTENTIONALLY LEFT BLANK.

iSBC 86/12™ SINGLE BOARD COMPUTER

9

• 8086 16 bit H-MOS microprocessor
central processor unit

32K bytes of dual-port read/write memory
with on-board refresh

Sockets for up to 16K-bytes of read only
memory

System memory expandable to
1 megabyte

24 programmable parallel I/O lines with
sockets for interchangeable line drivers
and terminators

Programmable synchronous/
asynchronous RS232C compatible serial
interface with software selectable baud
rates

Two programmable 16-bit BCD or binary
counters

9 levels of vectored interrupt control,
expandable to 65 levels

Auxiliary power bus, memory protect and
power fail interrupt control logic for
read/write memory battery backup

MULTIBUS interface for multimaster
configurations and system expansion

Compatible with iSBC 80 family single
board computers, memory, digital and
analog I/O, and peripheral controller
boards

The iSBC 86/12 Single Board Computer is a member of Intel's complete line of OEM microcomputer systems which take full advantage of Intel's LSI technology to provide economical self-contained computer based solutions for OEM applications. The iSBC 86/12 is a complete computer system on a single 6.75 x 12.00-inch printed circuit card. A CPU, system clock, read/write memory, nonvolatile read only memory, I/O ports and drivers, serial communications interface, priority interrupt logic and programmable timers, all reside on the board. Full MULTIBUS interface logic is included to offer compatibility with the OEM Microcomputer Systems family of Single Board Computers, expansion memory options, digital and analog I/O expansion boards and peripheral controllers.

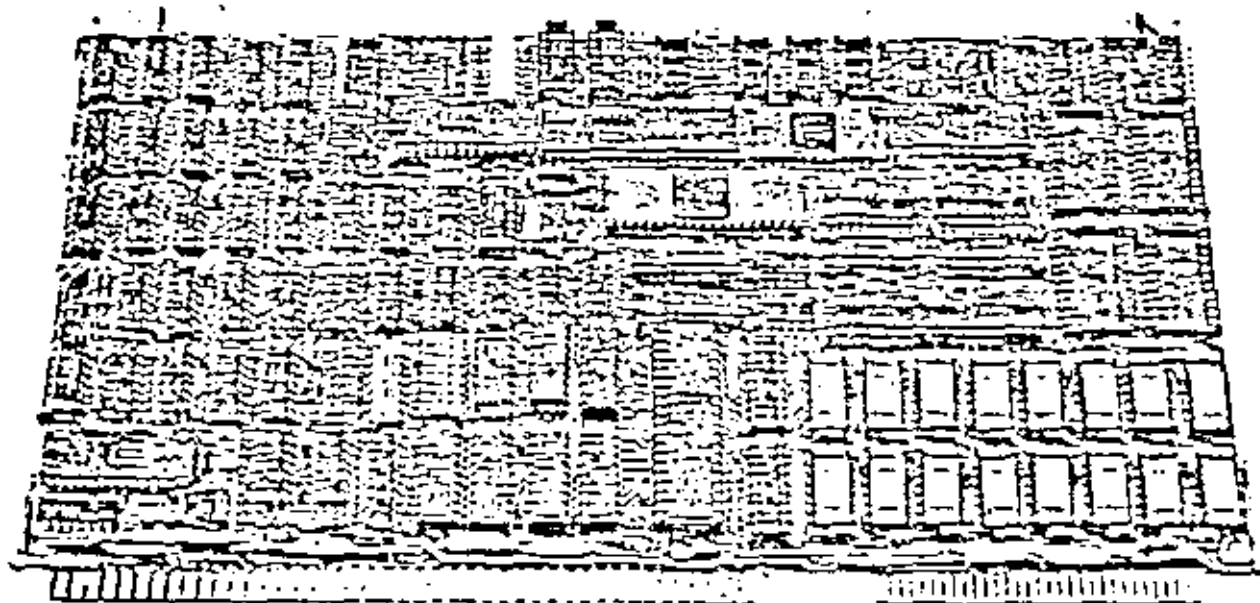

expansion through the use of other 8- and 16-bit iSBC computers, memory and I/O expansion boards.

RAM Capabilities

The iSBC 86/12 contains 32K-bytes of dynamic read/write memory using Intel® 2117 RAMs. Power for the on-board RAM and refresh circuitry may be optionally provided on an auxiliary power bus, and memory protect logic is included for RAM battery backup requirements. The iSBC 86/12 contains a dual port controller which allows access to the on-board RAM from the iSBC 86/12's CPU and from any other MULTIBUS master via the system bus. The dual port controller allows 8- and 16-bit accesses from the MULTIBUS and the on-board CPU transfers data to RAM over a 16-bit data path. Priorities have been established such that memory refresh is guaranteed by the on-board refresh logic and that the on-board CPU has priority over MULTIBUS requests for access to RAM. The dual-port controller includes independent addressing logic for RAM access from the on-board CPU and from the MULTIBUS. The on-board CPU will always access RAM starting at location 00000h. Address jumpers allow on-board RAM to be located starting on any 8K-byte boundary within a 1 megabyte address range for accesses from the MULTIBUS. In conjunction with this feature, the iSBC 86/12 has the ability to protect on-board memory from MULTIBUS access to any contiguous 8K-byte segments. These features allow multiprocessor systems to establish local memory for each processor and shared system (MULTIBUS) memory configurations where the total system memory size (including local on-board memory) can exceed 1 megabyte without addressing conflicts.

EPROM/ROM Capabilities

Four sockets are provided for up to 16K-bytes of non-volatile read only memory on the iSBC 86/12. ROM may be added in 2K-byte increments up to a maximum of 4K-bytes by using Intel 2758 electrically programmable ROMs (EPROMs); in 4K-byte increments up to 8K-bytes by using Intel 2716 EPROMs or Intel 2316E masked ROMs; or in 8K-byte increments up to 16K-

bytes by using Intel 2332 ROMs. On-board ROM is accessed via 16 bit data paths. System memory size is easily expanded by the addition of MULTIBUS compatible memory boards available in the iSBC 80/86 family.

Parallel I/O Interface

The iSBC 86/12 contains 24 programmable parallel I/O lines implemented using the Intel 8255A Programmable Peripheral Interface. The system software is used to configure the I/O lines in any combination of unidirectional input/output and bidirectional ports indicated in Table 1. Therefore, the I/O interface may be customized to meet specific peripheral requirements. In order to take full advantage of the large number of possible I/O configurations, sockets are provided for interchangeable I/O line drivers and terminators. Hence, the flexibility of the I/O interface is further enhanced by the capability of selecting the appropriate combination of optional line drivers and terminators to provide the required sink current, polarity, and drive/termination characteristics for each application. The 24 programmable I/O lines and signal ground lines are brought out to a 50-pin edge connector that mates with flat, woven, or round cable.

Serial I/O

A programmable communications interface using the Intel 8251A Universal Synchronous/Asynchronous Receiver/Transmitter (USART) is contained on the iSBC 86/12. A software selectable baud rate generator provides the USART with all common communication frequencies. The USART can be programmed by the system software to select the desired asynchronous or synchronous serial data transmission technique (including IBM Bi-Sync). The mode of operation (i.e., synchronous or asynchronous), data format, control character format, parity, and baud rate are all under program control. The 8251A provides full duplex, double buffered transmit and receive capability. Parity, overrun, and framing error detection are all incorporated in the USART. The RS232C compatible interface on each board, in conjunction with the USART, provides a

Port	Lines (qty)	Mode of Operation				Bidirectional	Control
		Unidirectional					
		Input		Output			
		Latched	Latched & Strobed	Latched	Latched & Strobed		
1	8	X	X	X	X		
2	8	X	X	X	X		
3	4	X		X		X ¹	
	4	X		X		X ¹	

Note

1. Part of port 3 must be used as a control port when either port 1 or port 2 are used as a latched and strobed input or a latched and strobed output port or port 1 is used as a bidirectional port.

Table 1. Input/Output Port Modes of Operation

direct interface to RS232C compatible terminals, cassettes, and asynchronous and synchronous modems. The RS232C command lines, serial data lines, and signal ground line are brought out to a 26 pin edge connector that mates with RS232C compatible flat or round cable. The ISBC 530 Teletypewriter Adapter provides an optically isolated interface for those systems requiring a 20 mA current loop. The ISBC 530 may be used to interface the ISBC 86/12 to teletypewriters or other 20 mA current loop equipment.

Programmable Timers

The ISBC 86/12 provides three independent, fully programmable 16-bit interval timers/event counters utilizing the Intel 8253 Programmable Interval Timer. Each counter is capable of operating in either BCD or binary modes. Two of these timers/counters are available to the systems designer to generate accurate time intervals under software control. Routing for the outputs and gate/trigger inputs of two of these counters is jumper selectable. The outputs may be independently routed to the 8259A Programmable Interrupt Controller

and to the I/O line drivers associated with the 8255A Programmable Peripheral Interface, or may be routed as inputs to the 8255A chip. The gate/trigger inputs may be routed to I/O terminators associated with the 8255A or as output connections from the 8255A. The third interval timer in the 8253 provides the programmable baud rate generator for the ISBC 86/12 RS232C USART serial port. In utilizing the ISBC 86/12, the systems designer simply configures, via software, each timer independently to meet system requirements. Whenever a given time delay or count is needed, software commands to the programmable timers/event counters select the desired function. Seven functions are available, as shown in Table 2. The contents of each counter may be read at any time during system operation with simple read operations for event counting applications, and special commands are included so that the contents can be read "on the fly".

MULTIBUS and Multimaster Capabilities

The MULTIBUS features asynchronous data transfers for the accommodation of devices with various transfer rates while maintaining maximum throughput. Twenty address lines and sixteen separate data lines eliminate the need for address/data multiplexing/demultiplexing logic used in other systems, and allow for data transfer rates up to 5 megawords/sec. A fast timer is included in the ISBC 86/12 which can be used to generate an interrupt if an addressed device does not respond within 6 msec.

Multimaster Capabilities — The ISBC 86/12 is a full computer on a single board with resources capable of supporting a great variety of OEM system requirements. For those applications requiring additional processing capacity and the benefits of multiprocessing (i.e., several CPUs and/or controllers logically sharing system tasks through communication over the system bus), the ISBC 86/12 provides full MULTIBUS arbitration control logic. This control logic allows up to three ISBC 86/12's or other bus masters, including ISBC 80 family MULTIBUS compatible 8-bit single board computers, to share the system bus in serial (daisy chain) priority fashion, and up to 16 masters to share the MULTIBUS with the addition of an external priority network. The MULTIBUS arbitration logic operates synchronously with a MULTIBUS clock (provided by the ISBC 86/12 or optionally provided directly from the MULTIBUS) while data is transferred via a handshake between the master and slave modules. This allows different speed controllers to share resources on the same bus, and transfers via the bus proceed asynchronously. Thus, transfer speed is dependent on transmitting and receiving devices only. This design prevents slow master modules from being handicapped in their attempts to gain control of the bus, but does not restrict the speed at which faster modules can transfer data via the same bus. The most obvious applications for the master-slave capabilities of the bus are multiprocessor configurations, high speed direct memory access (DMA) operations, and high speed peripheral control, but are by no means limited to these three.

Function	Operation
Interrupt on terminal count	When terminal count is reached, an interrupt request is generated. This function is extremely useful for generation of real-time clocks.
Programmable one-shot	Output goes low upon receipt of an external trigger edge or software command and returns high when terminal count is reached. This function is retriggerable.
Rate generator	Divide by N counter. The output will go low for one input clock cycle, and the period from one low going pulse to the next is N times the input clock period.
Square-wave rate generator	Output will remain high until one-half the count has been completed, and go low for the other half of the count.
Software triggered strobe	Output remains high until software loads count (N). N counts after count is loaded, output goes low for one input clock period.
Hardware triggered strobe	Output goes low for one clock period N counts after rising edge counter trigger input. The counter is retriggerable.
Event counter	On a jumper selectable basis, the clock input becomes an input from the external system. CPU may read the number of events occurring after the counting "window" has been enabled or an interrupt may be generated after N events occur in the system.

Table 2. Programmable Timer Functions

Interrupt Capability

The ISBC 86/12 provides 9 vectored interrupt levels. The highest level is the NMI (Non-Maskable Interrupt) line which is directly tied to the 8085 CPU. This interrupt cannot be inhibited by software and is typically used for signalling catastrophic events (i.e., power failure). On servicing this interrupt, program control will be implicitly transferred through location 00008_H. The Intel 8259A Programmable Interrupt Controller (PIC) provides vectoring for the next eight interrupt levels. As shown in Table 3, a selection of four priority processing modes is available to the systems designer for use in designing request processing configurations to match system requirements. Operating mode and priority assignments may be reconfigured dynamically via software at any time during system operation. The PIC accepts interrupt requests from the programmable parallel and serial I/O interfaces, the programmable timers, the system bus, or directly from peripheral equipment. The PIC then determines which of the incoming requests is of the highest priority, determines whether this request is of higher priority than the level currently being serviced, and, if appropriate, issues an interrupt to the CPU. Any combination of interrupt levels may be masked, via software, by storing a single byte in the interrupt mask register of the PIC. The PIC generates a unique memory address for each interrupt level. These addresses are equally spaced at 4 byte intervals. This 32-byte block may begin at any 32-byte boundary in the lowest 1K-bytes of memory,* and contains unique instruction pointers and code segment offset values (for expanded memory operation) for each interrupt level. After acknowledging an interrupt and obtaining a device identifier byte from the 8259A PIC, the CPU will store its status flags on the stack and execute an indirect CALL instruction through the vector location (derived from the device identifier) to the interrupt service routine. In systems requiring additional interrupt levels, slave 8259A PIC's may be interfaced via the MULTIBUS, to generate additional vector addresses, yielding a total of 65 unique interrupt levels.

Interrupt Request Generation — Interrupt requests may originate from 16 sources. Two jumper selectable interrupt requests can be automatically generated by the programmable peripheral interface when a byte of information is ready to be transferred to the CPU (i.e., input buffer is full) or a byte of information has been transferred to a peripheral device (i.e., output buffer is empty). Two jumper selectable interrupt requests can be automatically generated by the USART when a character is ready to be transferred to the CPU (i.e., receive channel buffer is full), or a character is ready to be transmitted (i.e., transmit channel data buffer is empty). A jumper selectable request can also be generated by each of the programmable timers. Eight additional

*Note: The first 32 vector locations are reserved by Intel for dedicated vectors. Users who wish to maintain compatibility with present and future Intel products should not use these locations for user-defined vector addresses.

Mode	Operation
Fully nested	Interrupt request line priorities fixed at 0 as highest, 7 as lowest.
Auto-rotating	Equal priority. Each level, after receiving service, becomes the lowest priority level until next interrupt occurs.
Specific priority	System software assigns lowest priority level. Priority of all other levels based in sequence numerically on this assignment.
Polled	System software examines priority-encoded system interrupt status via interrupt status register.

Table 3. Programmable Interrupt Modes

interrupt request lines are available to the user for direct interface to user designated peripheral devices via the system bus, and two interrupt request lines may be jumper routed directly from peripherals via the parallel I/O driver/terminator section.

Power-Fail Control

Control logic is also included to accept a power-fail interrupt in conjunction with the AC-low signal from the ISBC 635 Power Supply or equivalent.

Expansion Capabilities

Memory and I/O capacity may be expanded and additional functions added using Intel MULTIBUS compatible expansion boards. High speed integer and floating point arithmetic capabilities may be added by using the ISBC 310 High Speed Mathematics Unit. Memory may be expanded to 1 Megabyte by adding user specified combinations of RAM boards, EPROM boards, or combination boards. Input/output capacity may be increased by adding digital I/O and analog I/O expansion boards. Mass storage capability may be achieved by adding single or double density diskette controllers. Modular expandable backplanes and cardcages are available to support multiboard systems.

Note: Certain system restrictions may be incurred by the inclusion of some of the ISBC 80 family options in an ISBC 86/12 system. Consult the Intel OEM Microcomputer System Configuration Guide for specific data.

System Development Capabilities

The development cycle of ISBC 86/12 products can be significantly reduced by using the floppy disk based Intellec® series microcomputer development systems. The Assembler, Locating Linker, Library Manager, Text Editor and system monitor are all supported by the ISIS-II disk based operating system. A minimum of 64K-bytes of RAM is needed in the Intellec system to support program development for the ISBC 86/12. To facilitate conversion of 8080A/8085A assembly language programs to run on the ISBC 86/12, CONV-86 is available under the ISIS-II operating system.

Interface and Execution Package — The iSBC 957 Interface and Execution Package allows the Intellec user to interface an iSBC 86/12 system to the development system. Included with the package are the necessary cables and software to allow transfer of files between the Intellec system and the iSBC 86/12. Additionally, the Intellec user can access a system monitor program (supplied on ROMs) resident in the iSBC 86/12 which allows access to programs loaded into the iSBC 86/12. The system monitor includes commands to examine and modify memory, registers and I/O ports. Additionally, breakpoints, searches, and other useful operations are included to simplify software debug. Used in conjunction with the iSBC 957 Package, iSBC 86/12 execution packages are offered

which include additional hardware such as the iSBC 860 system chassis to mount and power the iSBC 86/12 for program development.

PL/M-86 — Intel's high level programming language. PL/M-86, is also available as an Intellec microcomputer development system option. PL/M-86 provides the capability to program in a natural, algorithmic language and eliminates the need to manage register usage or allocate memory. PL/M-86 programs can be written in a much shorter time than assembly language programs for a given application. PL/M-86 includes byte and word, integer, pointer and floating point (32-bit) data types and also includes conditional compilation and macro features.

SPECIFICATIONS

Word Size

Instruction — 8, 16, 24, or 32 bits

Data — 8, 16 bits

Cycle Time

Basic Instruction Cycle — 1.2 μ sec
— 400 nsec (assumes instruction in the queue)

Note: Basic instruction cycle is defined as the latest instruction time (i.e., two clock cycles)

Memory Addressing

On Board ROM/EPROM — FF000-FFFF_H (using 2758 EPROM's); FE000-FFFF_H (using 2316E ROM's or 2716 EPROM's); and FC000-FFFF_H (using 2332 ROM's).

On-board RAM — 32k bytes of dual port RAM. CPU Access: 00000-07FFF_H. MULTIBUS Access is jumper selectable for any 8K-byte boundary, but not crossing a 128K byte boundary. Access for 8K, 16K, 24K, or 32K bytes may be selected for CPU use only.

Memory Capacity

On-Board Read Only Memory — 16K bytes (sockets only)

On-Board RAM — 32K bytes

Off-Board Expansion — Up to 1 megabyte in user specified combinations of RAM, ROM, and EPROM.

Note: Read only memory may be added in 2K, 4K, or 8K-byte increments.

I/O Addressing

On-Board Programmable I/O

Port	8255A				USART	
	1	2	3	Control	Data	Control
Address	C8	CA	CC	CE	D8 or DC	DA or DE

I/O Capacity

Parallel — 24 programmable lines using one 8255A.

Serial — 1 programmable line using one 8251A.

Serial Communications Characteristics

Synchronous — 5—8 bit characters; internal or external character synchronization; automatic sync insertion.

Asynchronous — 5—8 bit characters; break character generation; 1, 1½, or 2 stop bits; false start bit detection.

Baud Rates

Frequency (kHz) (Software Selectable)	Baud Rate (Hz)		
	Synchronous	Asynchronous	
		~ 16	~ 84
153.8	—	9600	2400
78.8	—	4800	1200
38.4	28400	2400	800
19.2	19200	1200	300
9.6	9600	600	150
4.8	4800	300	75
2.4	2400	150	—
1.28	1750	110	—

Note: Frequency selected by I/O write of appropriate 16-bit frequency factor to baud rate register (8253 Timer 2).

Interrupts

Addresses for 8259A Registers (Hex notation I/O address space)

C0 or C4 Write: Initialization Command Word 1 (ICW1) and Operation Control Words 2 and 3 (OCW2 and OCW3)

Read: Status and Poll Registers

C2 or C6 Write: 1CW2, 1CW3, 1CW4, 0CW1 (Mask Register)

Read: 0CW1 (Mask Register)

Note: Several registers have the same physical address; sequence of access and one data bit of control word determining which register will respond.

Interrupt Levels — 8086 CPU includes a non-maskable interrupt (NMI) and a maskable interrupt (INTR). NMI interrupt is provided for catastrophic events such as power failure. NMI vector address is 00008. INTR-inter-

Interrupt is driven by on-board 8259A PIC, which provides 4-bit identifier of interrupting device to CPU. CPU multiplies identifier by four to derive vector address. Jumpers select interrupts from 18 sources without necessity of external hardware. PIC may be programmed to accommodate edge-sensitive or level-sensitive inputs.

Timers

Register Addresses (Hex notation, I/O address space)

- D6 Control register
- D0 Timer 0
- D2 Timer 1
- D4 Timer 2

Note:

Timer counts loaded as two sequential output operations to same address as given.

Input Frequencies

Reference: 2.46 MHz \pm 0.1% (0.041 μ s period, nominal); 1.23 MHz \pm 0.1% (0.81 μ s period, nominal); or 153.60 kHz \pm 0.1% (6.51 μ s period nominal).

Note:

Above frequencies are user selectable.

Event Rate: 2.46 MHz max

Output Frequencies/Timing Intervals

Function	Single Timer/Counter		Dual Timer/Counter (Two Timers Cascaded)	
	Min	Max	Min	Max
Real-time interrupt	1.63 μ s	427.1 ms	3.26 s	466.50 min
Programmable one-shot	1.63 μ s	427.1 ms	3.26 s	466.50 min
Rate generator	2.342 Hz	613.5 kHz	0.000036 Hz	306.6 kHz
Square-wave rate generator	2.342 Hz	613.5 kHz	0.000036 Hz	306.6 kHz
Software triggered strobe	1.63 μ s	427.1 ms	3.26 s	466.50 min
Hardware triggered strobe	1.63 μ s	427.1 ms	3.26 s	466.50 min
Event counter	—	2.46 MHz	—	—

Interfaces

- MULTIBUS — All signals TTL compatible
- Parallel I/O — All signals TTL compatible
- Interrupt Requests — All TTL compatible
- Timer — All signals TTL compatible
- Serial I/O — RS232C compatible, data set configuration

System Clock (8086 CPU)

5.00 MHz \pm 0.1%

Auxiliary Power

An auxiliary power bus is provided to allow separate power to RAM for systems requiring battery backup of read/write memory. Selection of this auxiliary RAM power bus is made via jumpers on the board.

Connectors

Interface	Pins (Qty)	Centers (in.)	Mating Connectors
Bus	86	0.156	CDC VP801E43A00A1
Parallel I/O	50	0.1	JM 3415-000 or TI H312125
Serial I/O	26	0.1	JM 3462-000 or TI H312113

Memory Protect

An active low TTL compatible memory protect signal is brought out on the auxiliary connector which, when asserted, disables read/write access to RAM memory on the board. This input is provided for the protection of RAM contents during system power down sequences.

Line Drivers and Terminators

I/O Drivers — The following line drivers are all compatible with the I/O driver sockets on the ISBC 86/12.

Driver	Characteristic	Sink Current (mA)
7438	I, OC	48
7437	I	48
7432	NI	16
7426	I, OC	16
7409	NI, OC	16
7408	NI	16
7403	I, OC	16
7400	I	16

Note:

I = inverting; NI = non-inverting; OC = open collector.

Port 1 of the 8255A has 20 mA totem-pole bidirectional drivers and 1 k Ω terminators.

I/O Terminators — 220 Ω /330 Ω divider or 1 k Ω pullup



Bus Drivers

Function	Characteristic	Sink Current (mA)
Data	Tri-state	50
Address	Tri-state	50
Commands	Tri-state	32

Physical Characteristics

- Width — 12.00 in. (30.48 cm)
- Height — 6.75 in. (17.15 cm)
- Depth — 0.70 in. (1.78 cm)
- Weight — 19 oz. (539 gm)

Electrical Characteristics

DC Power Requirements

Configuration	Current Requirements			
	V _{CC} = +5V ±5% (max)	V _{DD} = -12V ±5% (max)	V _{BB} = -5V ±5% (max)	V _{AA} = -12V ±5% (max)
Without EPROM ¹	5.2A	350 mA	—	40 mA
RAM Only ²	350 mA	40 mA	10 mA	—
With ISBC 530 ⁴	5.2A	450 mA	—	140 mA
With 4K EPROM ³ (using 2750)	5.5A	450 mA	—	140 mA
With 8K ROM ³ (using 2316E)	6.1A	450 mA	—	140 mA
With 8K EPROM ³ (using 2716)	5.5A	450 mA	—	140 mA
With 16K ROM ³ (using 2332)	5.4A	450 mA	—	140 mA

Notes:

- Does not include power for optional ROM/EPROM, I/O drivers, and I/O terminators.
- Does not include power required for optional ROM/EPROM, I/O drivers and I/O terminators.
- RAM chips powered via auxiliary power bus.
- Does not include power for optional ROM/EPROM, I/O drivers, and I/O terminators. Power for ISBC 530 is supplied via serial port connector.
- Includes power required for four ROM/EPROM chips, and I/O terminators installed for 16 I/O lines; all terminator inputs low.

Environmental Characteristics

Operating Temperature — 0°C to 55°C

Relative Humidity — to 90% (without condensation)

Reference Manual

9800645A — ISBC 56/12 Single Board Computer hardware Reference Manual (NOT SUPPLIED)

Reference manuals are shipped with each product only if designated SUPPLIED (see above). Manuals may be ordered from any Intel sales representative, distributor office or from Intel Literature Department, 3065 Bowers Avenue, Santa Clara, California 95051.

ORDERING INFORMATION

Part Number	Description
SBC 86/12	Single Board Computer with 32K bytes RAM

Intel Corporation
3065 Bowers Avenue
Santa Clara, California 95051
Tel: (408) 737-1000
TWX: 910-338-0026
TELEX: 34-6372

U.S.
REGIONAL SALES OFFICES

WESTERN
CALIFORNIA
Intel Corp.^{*}
1651 East 4th Street
Suite 150
Santa Ana 92701
Tel: (714) 835-9642
TWX: 910-593-1114

MID-WESTERN
ILLINOIS
Intel Corp.^{*}
900 Jorie Boulevard
Suite 220
Oakbrook 60521
Tel: (312) 325-3510
TWX: 910-631-6381

EASTERN
OHIO
Intel Corp.^{*}
8312 North Main Street
Dayton 45415
Tel: (513) 890-5350
TELEX: 258-004

ATLANTIC
MASSACHUSETTS
Intel Corp.^{*}
187 Bulfinch Road, Suite 100
Chelmsford 01824
Tel: (617) 256-6567
TWX: 710-343-6333

OVERSEAS
MARKETING OFFICES

ORIENT
JAPAN
Intel Japan Corporation^{*}
Flower Hill-Shinmachi East Bldg
1-23-9, Shinmachi, Setagaya-ku
Tokyo 154
Tel: (03) 426-3051
TELEX: 781-09426

EUROPE
BELGIUM
Intel International^{*}
Rue du Moulin à Pâtes
31-Boite 1
B-1160 Brussels
Tel: (02) 560 10 10
TELEX: 24814

*Note New Telephone Number

MSE D-16

*Field Application Location

- INTEL MDS - II

- TEKTRONIX 8001

THIS PAGE INTENTIONALLY LEFT BLANK.

MODEL 240 INTELLEC[®] SERIES II MICROCOMPUTER DEVELOPMENT SYSTEM

Complete microcomputer development center for Intel MCS-80™, MCS-85™, MCS-86™, and MCS-48™ microprocessor families

64K bytes RAM memory

Self-test diagnostic capability

Built-in interfaces for high speed paper tape reader/punch, printer, and universal PROM programmer

Integral CRT with detachable upper/lower case typewriter-style full ASCII keyboard

Integral 250K-byte floppy disk plus 7.3 million bytes (expandable to 15.6M bytes) of hard disk storage

Powerful ISIS-II Diskette Operating System software with relocating macroassembler, linker, and loader

Supports PL/M, FORTRAN, BASIC and COBOL high level languages

Software compatible with previous Intellec systems

The Model 240 Intellec Series II Microcomputer Development System is a complete center for the development of microcomputer-based products. It includes a CPU, 64K bytes of RAM, 4K bytes of ROM memory, a 2000-character CRT, a detachable full ASCII keyboard, and 250K-byte floppy diskette drive. A hard disk subsystem provides over 7 million bytes of on-line data storage. Powerful ISIS-II Diskette Operating System software allows the Model 240 to be used quickly and efficiently for assembling and/or compiling and debugging programs for Intel's MCS-80, MCS-85, MCS-86, or MCS-48 microprocessor families without the need for handling paper tape. ISIS-II performs all the handling operations, leaving the user free to concentrate on the details of his own application. When used in conjunction with an optional in-circuit emulator (ICE™) module, the Model 240 provides all the hardware and software development tools necessary for the rapid development of a microcomputer-based product.

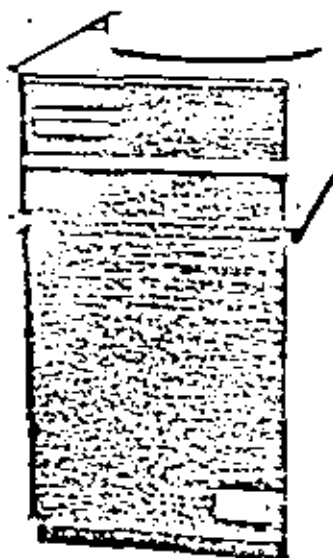

the CRT, keyboard, and standard Intellec peripherals including printer, high speed paper tape reader/punch, and universal PROM programmer. The IOC contains its own independent microprocessor, also an 8080A-2. The CPU controls all I/O operations as well as supervising communications with the IPB. 8K bytes of ROM contain all I/O control firmware. 8K bytes of RAM are used for CRT screen refresh storage. These do not occupy space in Intellec Series II main memory since the IOC is a totally independent microcomputer subsystem.

Integral CRT

Display — The CRT is a 12-inch raster scan type monitor with a 50/60 Hz vertical scan rate and 15.5 kHz horizontal scan rate. Controls are provided for brightness and contrast adjustments. The interface to the CRT is provided through an Intel 8275 single-chip programmable CRT controller. The master processor on the IPB transfers a character for display to the IOC, where it is stored in RAM. The CRT controller reads a line at a time into its line buffer through an Intel 8257 DMA controller and then feeds one character at a time to the character generator to produce the video signal. Timing for the CRT control is provided by an Intel 8253 interval timer. The screen display is formatted as 25 rows of 80 characters. The full set of ASCII characters is displayed, including lower case alphas.

Keyboard — The keyboard interfaces directly to the IOC processor via an 8-bit data bus. The keyboard contains an Intel UPI-41 Universal Peripheral Interface, which scans the keyboard, encodes the characters, and buffers the characters to provide N-key rollover. The keyboard itself is a high quality typewriter style keyboard containing the full ASCII character set. An upper/lower case switch allows the system to be used for document preparation. Cursor control keys are also provided.

Peripheral Interface

A UPI-41 Universal Peripheral Interface on the IOC board provides interface for other standard Intellec peripherals including a printer, high speed paper tape reader, high speed paper tape punch, and universal PROM programmer. Communication between the IPB and IOC is maintained over a separate 8-bit bidirectional data bus. Connectors for the four devices named above, as well as the two serial channels, are mounted directly on the IOC itself.

Control

User control is maintained through a front panel, consisting of a power switch and indicator, reset/boot switch, run/halt light, and eight interrupt switches and indicators. The front panel circuit board is attached directly to the IPB, allowing the eight interrupt switches to connect to the primary 8259, as well as to the Intellec Series II bus.

Disk System

The Intellec Series II Hard Disk System provides direct access bulk storage, intelligent controller, and a disk drive containing one fixed platter and one removable cartridge. Each provides 3.5 million bytes of storage with a data transfer rate of 2.5 Mbits/second. The controller is implemented with Intel's powerful Series 3000 Bipolar Microcomputer Set. The controller provides an interface to the Intellec Series II system bus, as well as supporting up to 2 disk drives. The disk system records all data in Double Frequency (DFM) on 2 surfaces per platter. Each platter can be write protected by a front panel switch. The disk system is capable of performing six different operations: recalculate, seek, format track, write data, read data, and verify CRC.

Disk Controller Boards — The disk controller consists of two boards, the channel board and the interface board. These two PC boards reside in the Intellec Series II system chassis and constitute the disk controller. The channel board receives, decodes and responds to channel commands from the 8080A-2 CPU in the Model 240. The interface board provides the disk controller with a means of communication with the disk drives and with the Intellec system bus. The interface board validates data during reads using a cyclic redundancy check (CRC) polynomial and generates CRC data during write operations. When the disk controller requires access to Intellec system memory, the channel board requests and maintains DMA master control of the system bus, and generates the appropriate memory command. The channel board also acknowledges I/O commands as required by the Intellec bus. In addition to supporting a second drive, the disk controller may co-reside with the Intel double-density controller to allow up to 17 million bytes of on-line storage.

Floppy Disk Drive

The floppy disk drive is controlled by an Intel 8271 single chip, programmable floppy disk controller. It transfers data via an Intel 8257 DMA controller between an IOC RAM buffer and the diskette. The 8271 handles reading and writing of data, formatting diskettes, and reading status, all upon appropriate commands from the IOC microprocessor.

MULTIBUS™ Capability

All Intellec Series II models implement the industry standard MULTIBUS. MULTIBUS enables several bus masters, such as CPU and DMA devices, to share the bus and memory by operating at different priority levels. Resolution of bus exchanges is synchronized by a bus clock signal derived independently from processor clocks. Read/write transfers may take place at rates up to 5 MHz. The bus structure is suitable for use with any In microcomputer family.

SPECIFICATIONS

Host Processor (IPB)

RAM — 64K (system monitor occupies 62K through 64K)
ROM — 4K (2K in monitor, 2K in boot/diagnostic)

Disk Drive

Type — 5440 top loading cartridge and one fixed platter
Tracks per inch — 200
Mechanical Sectors per Track — 12
Recording Technique — double frequency (FM)
Tracks per Surface — 480
Density — 2,200 bits/inch
Bits per Track — 62,500
Recording Surfaces per Platter — 2

Disk System Capacity

Per Surface — 15M bits
Per Platter — 29M bits
Per Drive — 59M bits
Per Drive — 7.3M bytes (formatted)

Disk Performance

Disk Transfer Rate — 2.5M bits/sec
Disk System Access Time —
Track to Track: 13 ms max
Full Stroke: 100 ms
Rotational Speed: 2,400 rpm

Diskette

Diskette System Capacity — 250K bytes (formatted)
Diskette System Transfer Rate — 160K bits/sec
Diskette System Access Time —
Track to Track: 10 ms max
Average Random Positioning: 260 ms
Rotational Speed: 360 rpm
Average Rotational Latency: 83 ms
Recording Mode: FM

Physical Characteristics

Width — 17.37 in. (44.12 cm)
Height — 15.81 in. (40.16 cm)
Depth — 19.13 in. (48.59 cm)
Weight — 73 lb. (33 kg)

Keyboard

Width — 17.37 in. (44.12 cm)
Height — 3.0 in. (7.62 cm)
Depth — 9.0 in. (22.86 cm)
Weight — 6 lb. (3 kg)

Disk Drive on Pedestal

Width — 18.5 in. (47.0 cm)
Height — 34.0 in. (86.4 cm)
Depth — 29.75 in. (75.6 cm)
Weight — 202 lb. (92 kg)

Electrical Characteristics

DC Power Supply

Volts Supplied	Amps Supplied	Typical System Requirements
+5 ± 5%	30	17.0
+12 ± 5%	2.5	1.1
-12 ± 5%	0.3	0.1
-10 ± 5%	1.0	0.08
+15 ± 5%	1.5	1.5
+24 ± 5%	1.7	1.7

*Not available on bus.

AC Requirements for Mainframe and 2 Drives —
110V, 60 Hz — 16 A (Mainframe — 5.2, 5.0 each drive)
220V, 50 Hz — 8.6 A (Mainframe — 3.1, 3.0 each drive)

Environmental Characteristics

Operating Temperature — 15°C to 32°C (60°F)
Humidity — 20% to 80%

Equipment Supplied

Model 240 Chassis
Integrated Processor Board (IPB)
I/O Controller Board (IOC)
32K RAM Board
CRT and Keyboard
One Hard-Disk Drive, Pedestal Mounted
Hard Disk Controller (two boards) with Cables
ROM-Resident System Monitor
ISIS-II System Diskette with MCS-80/MCS-85
Macroassembler
Disk Cartridge (blank 5440 type)

Reference Manuals

9800558 — A Guide to Microcomputer Development Systems (SUPPLIED)
9800559 — Intellec Series II Installation and Service Guide (SUPPLIED)
9800306 — ISIS-II System User's Guide (SUPPLIED)
9800556 — Intellec Series II Hardware Reference Manual (SUPPLIED)
9800301 — 8080/8085 Assembly Language Programming Manual (SUPPLIED)
9800292 — ISIS-II 8080/8085 Assembler Operator's Manual (SUPPLIED)
9800605 — Intellec Series II Systems Monitor Source Listing (SUPPLIED)
9800554 — Intellec Series II Schematic Drawings (SUPPLIED)
9800943 — Hard Disk Subsystem Operation and Checkout (SUPPLIED)

Additional manuals may be ordered from any Intel sales representative or distributor office, or from Intel Literature Department, 3065 Bowers Avenue, Santa Clara, California 95051.

ORDERING INFORMATION

23

Part Number	Description
MDS-240*	Intellic Series II Model 240 Microcomputer Development System (110V/60 Hz)
MDS-241*	Intellic Series II Model 240 Microcomputer Development System (220V/50 Hz)

MDS is an ordering code only, and is not used as a product name or trademark. MDS* is a registered trademark of Mphawk Data Sciences Corp.

intel

27

INTEL CORPORATION, 3065 Bowers Avenue, Santa Clara, CA 95051 • 4081 987 8080
 Printed in U.S.A. MS2/0873/14/DA 9L

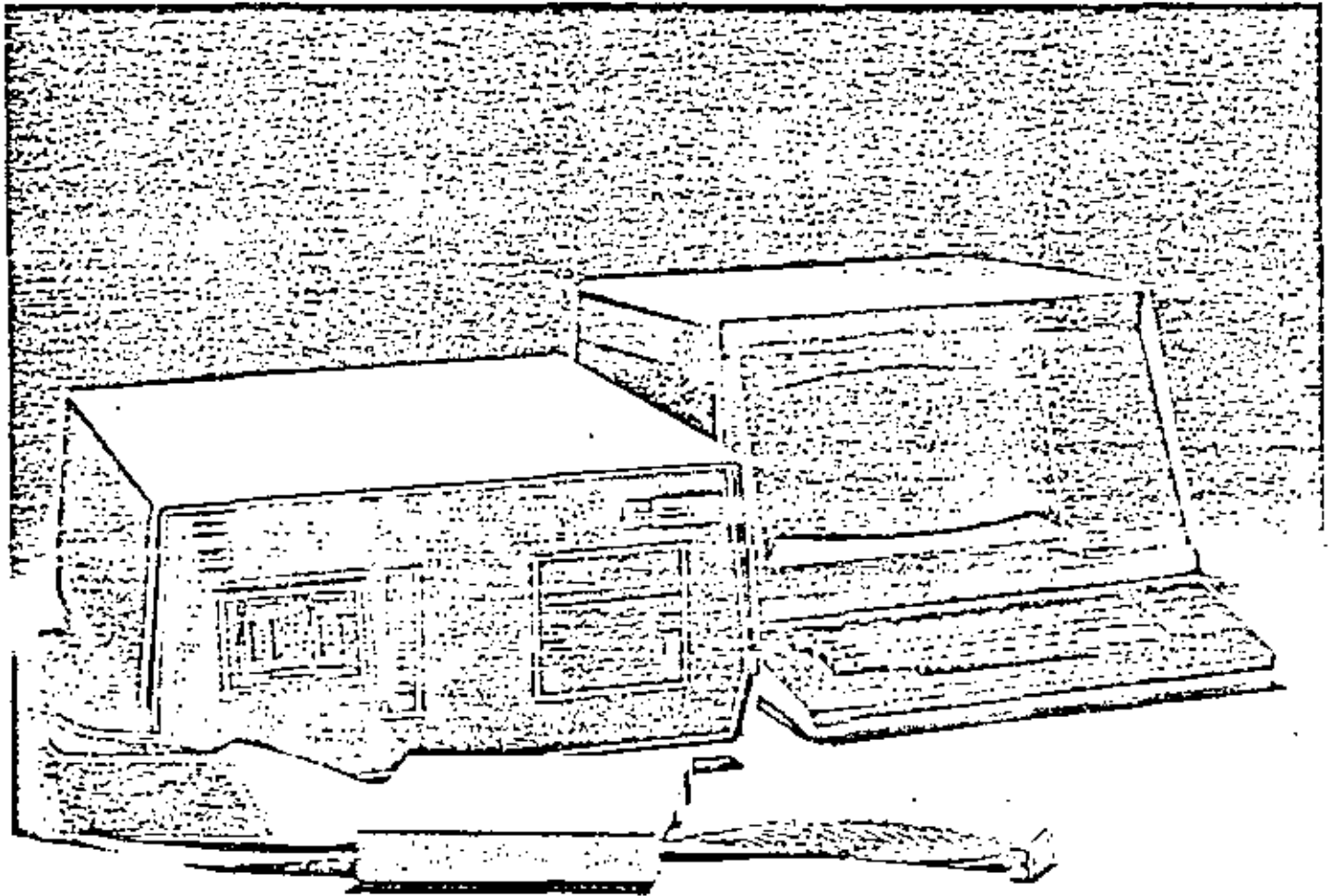

Multiple Microprocessor Support
In-Prototype Test and Emulation
Real-Time Prototype Analyzer Option

The 8001 Microprocessor Development Lab consists of the 8001 Mainframe with 16K of Program Memory. Microprocessor Support Packages are available as options. A Microprocessor Support Package includes an emulator ROM, an emulator processor, and a prototype controller probe. The CT8100 CRT Terminal, CT8101 TTY Terminal, LP5000 Line Printer, or 4024-4025 Computer Display Terminals are recommended optional peripherals.

The 8001 Microprocessor Lab is a total hardware debugging system for the design of microprocessor-based products. A key feature is its ability to support many microprocessor chips, including the Intel 8080A, 8085A, Motorola 6800, Texas Instruments TMS9900, 3870/72, F8 and Zilog Z-80A. In addition to multiple microprocessor support, the 8001 offers three emulation modes for software debugging, partial and full emulation, as well as a real-time prototype analyzer option with all the capabilities of a microprocessor analyzer.

Three Emulation Modes

In a typical design sequence, software is first developed independently using time-sharing, a minicomputer, or some other means. It is then downloaded to the 8001. At this point the in-prototype emulation and software/hardware integration capabilities of the 8001 come into play.

In emulation mode 0, the software runs only on the emulator processor. This enables the program to be debugged on a microprocessor virtually identical to the one that will ultimately be used in the completed product. In emulation modes 1 and 2, the prototype control probe is connected to the emulator processor at one end and plugged into the empty microprocessor socket in the prototype circuitry at the other.

Partial emulation (mode 1) lets the user release control in methodical steps from the 8001 to the prototype. The developmental software runs using 8001 memory space and prototype I/O and clock. The 8001 memory mapping feature allows memory to be gradually mapped over to the prototype by address blocks. Throughout partial emulation, the user has access to prototype circuitry via the powerful 8001 debugging system, which enables him to trace, set breakpoints, examine and change memory and register contents.

Full emulation (mode 2) lets the user exercise the program on the now stand-alone prototype while still maintaining complete control through the Microprocessor Lab. All I/O and timing functions are directed by the prototype; all memory has been mapped over to the prototype; and only the prototype control probe is still in place, emulating the target microprocessor. Although the prototype is effectively freestanding, then, the user may still direct program activity at the prototype end of the probe, from the 8001.

Hardware Trace Option

The optional Real-Time Prototype Analyzer enables the user to dynamically monitor the prototype address bus, data bus, and up to eight other locations on the prototype circuit board. Prototype activity is monitored at full speed, without stopping or slowing up the microprocessor in mode 2. This enables the designer to locate critical timing problems and hardware/software sequence problems. Full speed emulation is also possible in mode 1 with most of the emulators. Refer to the specific emulator data sheet for exact performance specifications.

In summary, then, each of the three emulation modes supports a specific phase of the product development cycle. Beginning with assembled source language, the designer

proceeds from software debugging (mode 0), to the sequential integration of program and circuit (mode 1), to the final integration and test of the stand-alone product (mode 2). The Real-Time Prototype Analyzer enhances modes 1 and 2 by allowing the user to monitor and access prototype activity.

8001 Characteristics

The 8001 Microprocessor Lab is a modular system whose mainframe houses up to 20 plug-in circuit boards. The system includes System Processor, Debug and Front-Panel I/O, Program Memory, System Communications, and System Memory modules. Emulator Processor module for the selected microprocessor is optional; its associated prototype control probe, and a ROM-based software module is included. Additional emulator processor packages are available in options for each microprocessor the system supports.

The Real-Time Prototype Analyzer module, additional 16K byte Program Memory modules, and EPROM Programmer modules for the 1702A or 2704/2708 are available as options. Optional peripherals include the TEKTRONIX CT8100 Crt Terminal, CT8101 TTY Terminal, 4024/4025 Computer Display Terminal, and the LP8200 Line Printer.

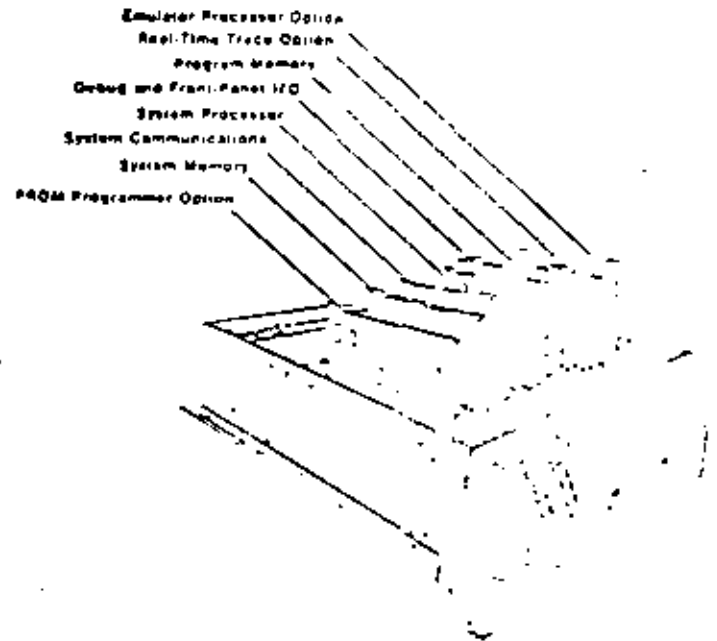

System Processor Module

The System Processor communicates directly with the system console and functions as the control for the 8001. It performs the output functions for all system peripheral devices through its own I/O port and controls access to the System Communications module. It addresses all other modules, such as the Debug module and the Emulator Prototype through the system bus. All power requirements are supplied from the system power supply.

Debug and Front-Panel I/O Module

The Debug and Front-Panel I/O module performs three functions. It controls the initialization and bus time-sharing of the System Processor and Emulator Processor module. It supports all software debug facilities, such as break, trace, and emulation programs, start at any location. It provides interface to the front panel.

System Memory Module

System Memory contains the operational software for the 8001. The module contains 64K bytes of main program memory, ROM, 16K bytes of RAM, and space for additional ROM. System Memory can be accessed through the System Processor.

Program Memory Module

Program Memory consists of 16K bytes of RAM; it is expandable to 64K bytes with optional 16K byte Program Memory modules. Program Memory may be accessed by the System Processor or the Emulator Processor.

System Communications Module

The System Communications module provides three RS-232-C compatible ports for interface with system peripherals. Two ports are designated for such peripherals as the TEKTRONIX LP8000 Line Printer; one is designated as a communications port for use with a modem. Baud rate is selectable for each port as 110, 300, 600, 1200, or 2400. The memory mapping feature included in this module allows the user to direct memory functions to prototype memory or 8001 Program Memory.

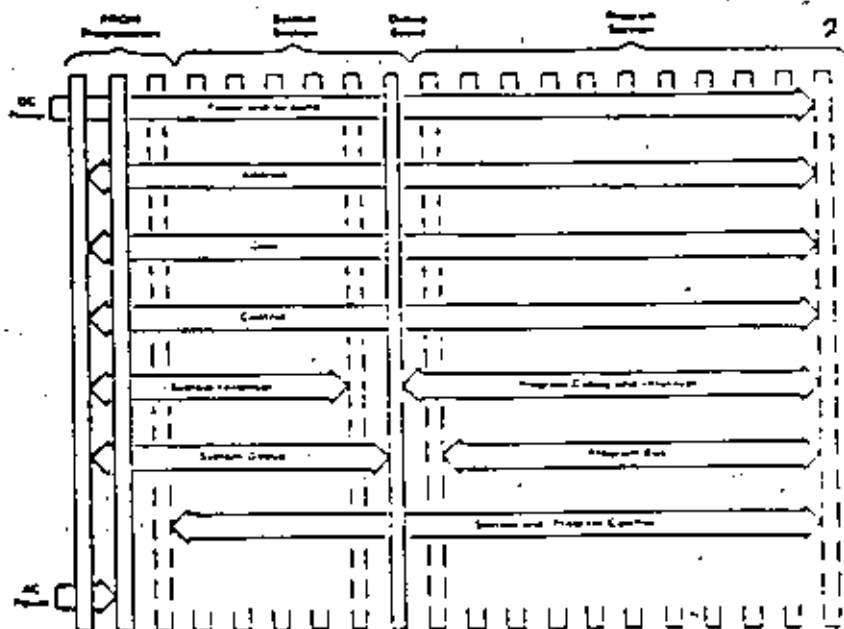

8001 Bus Diagram

Bus Organization

The Debug and Front-Panel I/O module divides the 8001 bus into System and Program sections. The 100-line bus is essentially universal: 16 bits of data, 16 bits of address, and the control lines are paralleled to all boards. (Exceptions are the independent de-

bug control, interrupt lines for System and Program, and special PROM power lines). This bus structure allows for freedom of memory and processor module placement in each half of the bus. I/O and memory address assignment is switch-selected on certain modules.

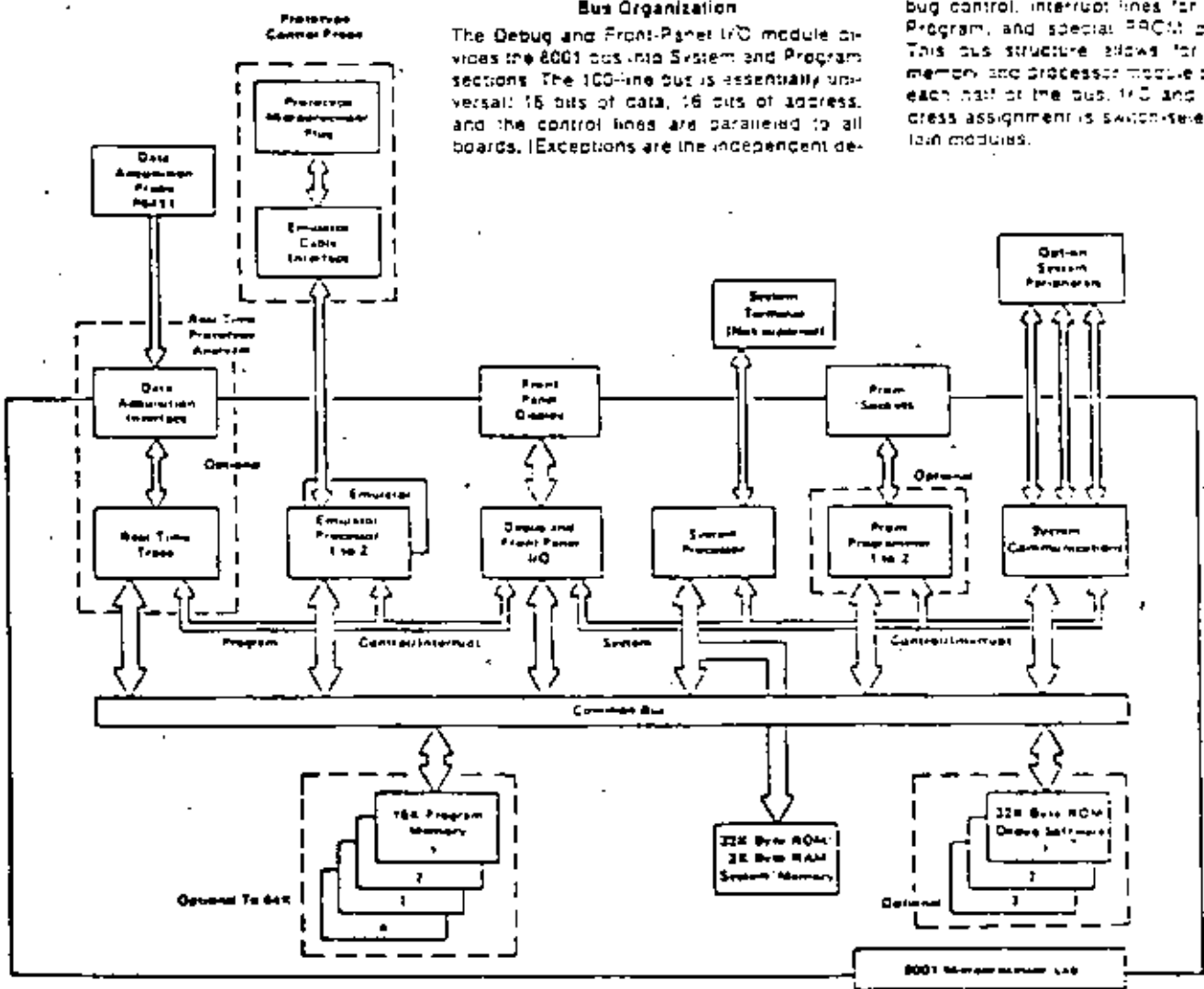

8001 SIMPLIFIED BLOCK DIAGRAM

SPECIFICATIONS

8001 PHYSICAL CHARACTERISTICS

Dimensions	cm	in
Height	24.88	9.8
Width	46.31	18.2
Length	57.3	22.5
	kg	lb
Weight	30	66

8001 ENVIRONMENTAL CHARACTERISTICS

Temperature Operating	0°C to +55°C (-32°F to 131°F)
Humidity	To 90% relative noncondensing
Altitude Operating	To 15,000 feet max.
Storage	To 30,000 feet max.

8001 ELECTRICAL CHARACTERISTICS

AC Input Voltages	115 VAC $\pm 10\%$ or 230 VAC $\pm 10\%$
Frequency Range	50 Hz (50 Hz special order)
Outputs	
Dual Supply VCC	-12 VCC / +12 VCC $\pm 1\%$ at 3 A
Single Voltage	+5.2 VCC $\pm 1\%$ at 25 A
Single Current	25 A
Line Regulation	
Dual Supply	$\pm 0.05\%$ for a 10% line change
Single Supply	$\pm 0.01\%$ for a 10% line change

Load Regulation	
Dual Supply	$\pm 0.05\%$ for a 50% load change
Single Supply	$\pm 0.05\%$ for a 50% load change

Output Ripple	
Dual Supply	1.5 mV (p-p) @ 4 mV (rms)
Single Supply	1.5 mV (p-p) @ 4 mV (rms)
Transient Response	
Dual Supply	30 μ s for 50% load change
Single Supply	30 μ s for 50% load change

Overload Protection	Automatic current limit "diode"
---------------------	---------------------------------

Adjustments	
Dual Supply	For -12 VCC to -15 VCC (Factory Set)
Single Supply	None

Fuses	Amps	SI	Volts AC
Primary	8		115
	3		230
40 VAC Second	0.5		
50 VAC Second	0.3		
± 12 VCC	2		115
	1		230

ORDERING INFORMATION

8001 Microprocessor Lab. \$4610

Option Description	Factory Price	Field Price
Option 01 486CA Microprocessor Support Package*	2680	3001901 2742
Option 02 486D Microprocessor Support Package*	3590	4001902 3741
Option 03 486CA Microprocessor Support Package*	2680	4001903 2742
Option 04 TW512CD Microprocessor Support Package*	4120	4001904 4110
Option 05 8285A Microprocessor Support Package*	3680	4001905 3742
Option 06 287072 Microcomputer Subsystem Package	4190	4001906 4240
Option 07 8K Microprocessor Support Package	4190	4001907 4240
Option 08 32K Program Memory Module	5100	
Option 09 Real-Time Arithmetic Analyzer	2500	4001908 2700
Option 10 T102 PROGRAM Programmer	450	4001909 500
Option 11 2704/1028 PROGRAM Programmer	600	4001910 650
Option 12 16K Program Memory Module	1550	4001911 1700

*A Microprocessor Support Package contains the 8001 emulator PROGRAM, an emulator processor board, and a prototype control probe. One support package is selected from the factory options with quantities of an 8001. Additional support packages may be selected from the field options.

Option Peripherals

CT8100 CRT Terminal	\$3495
CT8101 TTY Terminal	\$5195
LP8200 Line Printer	\$2095
4024 Computer Display Terminal with Option 20*	\$2045
4025 Computer Display Terminal with Option 20*	\$2045

*Option 20 16K Video Display Memory is required for proper 8001 operation.

STANDARD ACCESSORIES

8001 Installation Guide	300-2701400
8001 Systems Users Manual	300-2684000
8001 System Reference Card	300-2671400

OPTIONAL ACCESSORIES

8001 Service Manual*	
RS232 Interconnector Cable 10 ft (300 cm)	212-0251400
Multi-Megam Interconnecting Cable 3 ft (100 cm)	212-0251400

*Available January, 1979

Z80A Emulator Processor and Prototype Control Probe

Data Sheet

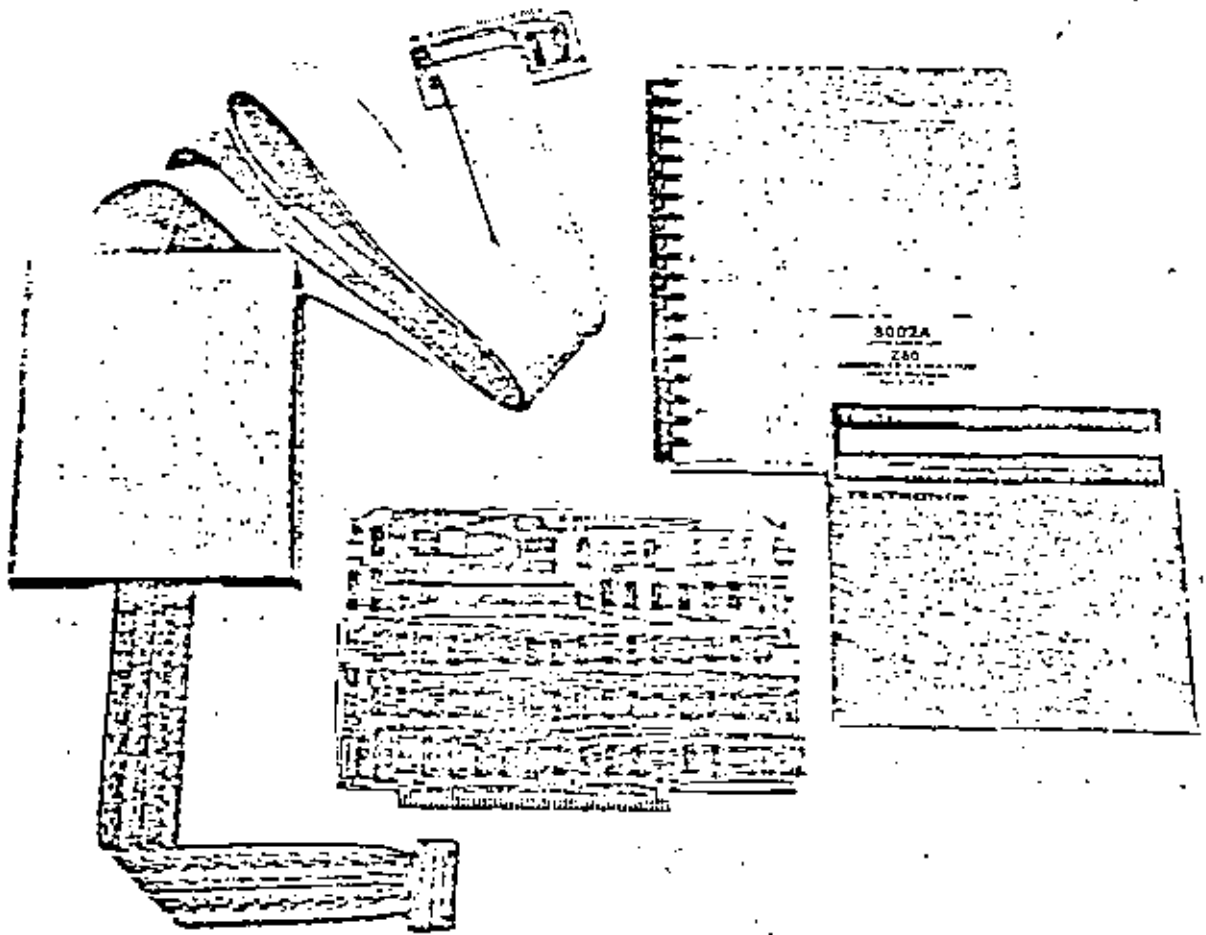

This emulator package supports the software development and prototyping stages of design with 8080, Z80 and Z80A microprocessors. It is one of many emulator packages offered as system options for the TEKTRONIX Microprocessor Labs.

The TEKTRONIX Z80A Emulator Processor and Prototype Control Probe aid in the development of prototype systems built around the Zilog Z80 and Z80A microprocessors. Operable with either the 8002A or 8001 Microprocessor Lab, these options provide the architectural capabilities necessary to emulate the Z80A in a prototype system.

Three progressive modes of emulation are available to support the designer during prototype development. Emulation is controlled at all times by the Microprocessor Lab's powerful debugging system software.

Emulation mode 0 is used strictly for software development. The designer executes the test program on the Z80A emulator processor, which is identical to the processor that will be used in the completed system. The designer is able to set breakpoints; examine and modify memory contents; and trace through the program to see the contents of the registers and the values of the status word, workspace pointer, and program counter.

In this emulation mode the Z80A and its microprocessor card can be located either in the emulator processor module or the prototype control probe.

Emulation mode 1 is used to begin software/hardware integration. The test program executes on the Z80A emulator processor, and all I/O functions are performed by prototype hardware. The program itself may execute both from 8002A/8001 program memory and from prototype memory with the Microprocessor Lab memory mapping capability.

In this mode the module microprocessor card is installed in the prototype control probe interface assembly, where it can now be used in any of the three emulation modes. The probe's 40 pin plug is inserted in the prototype's microprocessor socket. This configuration moves the emulator processor closer to the prototype, thus alleviating delay and propagation problems that might occur at the Z80A's 4 MHz maximum operating speed.

Emulation mode 2 is used to complete system integration. The test program still executes on the emulator processor, but all programmed functions and I/O functions are now performed by the prototype via the control probe under the control of the Microprocessor Lab.

*Z80 and Z80A are trademarks of Zilog for a particular type of microprocessor. Tektronix, Inc., does not guarantee that other vendors' versions of the Z80 will be compatible with the TEKTRONIX Microprocessor Labs.

The Real-Time Prototype Analyzer, available as a Microprocessor Lab option, functions in all emulation modes. Operating as a microprocessor analyzer, this option enables the designer to monitor 43 channels of data simultaneously, including the prototype address bus, data bus, control signals such as R/W, M/I/O, and Fetch, and up to 8 other locations acquired via the option's general-purpose logic probe.

Z80A EMULATOR SUPPORT PACKAGE CHARACTERISTICS

PHYSICAL CHARACTERISTICS	
Length	8 ft. of cable from the emulator processor to the interface assembly, 1 ft. of cable from the interface assembly to the 40 pin plug.
Cable Configuration	2 40 conductor ribbon cables with chassis ground plane and signal pairs.
Termination	2 40 conductor twisted pair cables.
Termination	The interface assembly contains necessary for data address and control from the Z80A emulator processor module.
Termination	Not terminated.

Timing Characteristics
The Z80A emulator processor was designed to match the characteristics of the Z80A microprocessor with two exceptions.

Prototype Clock	The prototype clock may not be stretched over a total of 10 μ s during any one memory or I/O request when a Microprocessor Lab memory access may occur in the next cycle. This exception is valid only if the prototype clock runs in excess of 1 MHz.
Wait	Wait state hardware interrupt must occur one-half cycle earlier than in a standard Z80A configuration. This means the wait must occur before the next to last trailing edge of the clock signal prior to M1.

ORDERING INFORMATION

Option Description	Part Number	Price
8001 Microprocessor Lab		
Option 02 Z80A Microprocessor Support Package		8002F03
Option 04 Real-Time Prototype Analyzer		8002F04
8002A Microprocessor Lab		
Option 02 Z80A Real-Time Support		8002F03
Option 04 Z80A Emulator Support		8002F04
Option 03 Z80A Prototype Control Probe		8002F03
Option 05 Z80A Program Memory Module		
Option 06 Real-Time Prototype Analyzer		8002F04
Option 07 1K Memory Program Module		1002F08

MDL/ μ Compiler for Software Development

MDL/ μ is a high level language designed specifically for use in microprocessor-based design. Its parent language is ANSI Minimal BASIC, a widely used and well understood programming format. MDL/ μ offers many enhancements of BASIC that make this new language an extremely effective design tool, while retaining the advantages of simplicity and easy learning found in BASIC.

One essential advantage of MDL/ μ is that it uses a compiler instead of an interpreter. Each program statement is translated to machine code only once, instead of every time the statement is executed. The result is faster and often more compact code for final program execution.

MDL/ μ allows a module-oriented approach to software development. Two statements, USES and PROVIDES, allow variables, functions, and procedures to be shared by programmers working on different modules of an overall program. The USES statement also allows direct access to absolute memory locations, I/O ports, and interrupts — all essential for proper control of hardware/software integration.

Variable names and strings have been considerably expanded with MDL/ μ . Variable names can contain up to six characters, the first alphabetic and the others alphanumeric, for easy identification during program development. Strings can vary in length from 1 to 255 characters instead of the unalterable 18 used in minimal BASIC. Substring replacement is also



MDL/ μ is a modified form of ANSI Minimal BASIC aimed specifically at microprocessor-based software design. The MDL/ μ Compiler is designed for use with the Tektronix 6802A Microprocessor Development Lab.

enhanced to assist in character manipulation.

I/O features include access to ports and absolute addressing of memory, which allows variables to be assigned a specific address. Both ASCII and general purpose binary file manipulations are possible through a series of I/O statements including OPEN, CLOSE, RESTORE, READ, WRITE, PRINT, and INPUT.

Among many other MDL/ μ enhancements to BASIC are logical operators (AND, OR, XOR, NOT) plus shift and rotate operations for bit manipulation, DISABLE and ENABLE to turn the interrupt off and on, and built-in code optimization.

The conversion of MDL/ μ source code to actual machine code is a three-step process. The first step converts MDL/ μ source code to assembly language source code which is stored on a file or device. The assembly source code contains the original MDL/ μ statements as comments preceding each block of assembly source code. At this stage, the assembly language can be further optimized by using the 8002A's powerful editor. In the second step, the assembler converts the assembly language source into object code. The third step is to link the object code with the run time support library and any other assembled object code modules.

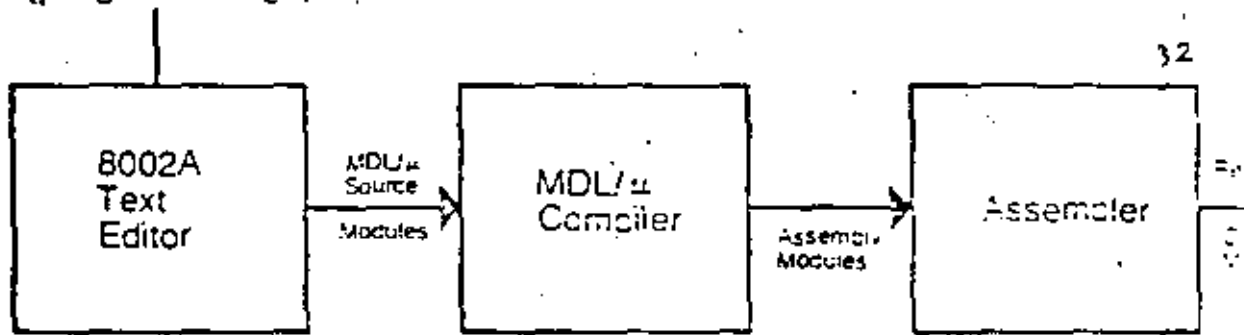

8002A Modular Development

MDL Applications

1. **MULTI-PROGRAMMER SOFTWARE PROJECTS**
Modular software development that allows local and global reference control between MDL or Assembler Modules.
2. **MICROPROCESSOR SYSTEMS PROGRAMMING**
High level control of memory and I/O with all run time code re-entrant for interrupt driven systems.
3. **ROM BASED PRODUCTS**
All run time code is ROM-able with stack and variable sections identified and grouped for ease in Link Time Location.
4. **LARGE APPLICATION PROGRAMS**
Reliable, easy to maintain code.
5. **HIGH VOLUME PRODUCTS**
Efficient code generation for minimum memory overhead.
6. **HIGHLY COMPETITIVE PRODUCTS**
Shortened development time, low maintenance costs, and ease of new feature addition.

- 4) High Level Language constructs for the 8002A and Microprocessor I/O:
—direct control of I/O ports and memory accessed as variables
—MDL constructs for vectored interrupts and mask instructions
- 5) Data handling capabilities:
—integer capability for one byte (0 to 255) and two byte (-32,768 to +32,767) variables with arithmetic, logical, relational and bit-manipulation operations — no real numbers or floating point.
—string capability with 0 to 255 byte length variables with concatenation and substring operations.
—One and two dimensional arrays of all data types.
- 6) Variable, procedure, function and modular identifiers may have one to six alphanumeric characters.

BENEFITS

Use of MDL.com:

- reduce the design time for your application
- improve the documentation of your programs
- increase the reliability of your software
- simplify and reduce the cost of program maintenance

FEATURES OF THE MODULAR DEVELOPMENT LANGUAGE

- 1) A true Compiler that generates executable (non interpretative) code:
 - produces linkable, relocatable, and ROM-able code
 - compiler output (assembly code) may be edited, if desired, for crucial optimizations or code modifications.
 - different sections of the output may be specified for ROM or RAM.
 - run-time support routines:
 - a) provide simple use of 8002A I/O facilities;
 - b) are linked with program only if referenced by program;
 - c) reduce size of object code (there is only one instance of that code sequence);
 - d) provide code which is locally optimized for efficient use of space.
 - e) provide re-entrant sub-routines;
 - f) allow object code to be linked with 8080A, 8085A, Z80 or 6800 assembly language modules.
- 2) Compiler, assembler, and linker form a modular programming facility:
 - programs may be written in modular components (MDL and assembly)
 - modules may have any number of functions and procedures.
 - procedures, functions, and variables defined in one module can be used by another.
 - module interfaces are completely described.
 - modules are separately compiled, then linked together.
 - incremental development is possible with module as "increment".

User-defined, multi-statement functions and procedures.

MDL KEYWORDS

LET	Assigns a value to a variable.
REM	Allows program documentation.
ENABLE	Enables interrupts.
DISABLE	Disables interrupts.
MASK *	Sets the interrupt mask state.
DIM	Specifies size and/or dimensions and reserves space for string, array, integer variables.
DEFUN	Begins a user-defined function.
DEFPR	Begins a user-defined procedure.
FNEND	Ends a user-defined function.
PREND	Ends a user-defined procedure.
MODULE	Specifies a module name, starting address and emulation mode.
MAIN	Indicates program starting address is contained in this module.
USES	Identifies externally defined functions, procedures, variables, ports, and interrupts available for internal use.
PROVIDES	Identifies internally defined functions, procedures and variables available for external use.
FUNCTION	Specifies a function that is used or provided by a module.
PROC	Specifies a procedure that is used or provided by a module.
VAR	Specifies a variable that is used or provided by a module.
PORT *	Defines an I/O port that is used by a module.
ORIGIN	Specifies a memory location for a port or variable.
MODE	Indicates the emulation mode in which the module runs.
GO TO	Transfers control to a specified line.
ON.GOTO	Transfers control to a selected line.
GOSUB	Transfers control to a specified line that begins a subroutine.
ON.GOSUB	Transfers control to a selected line that begins a subroutine.

*8080A, *8085A, *6800A, *6805A

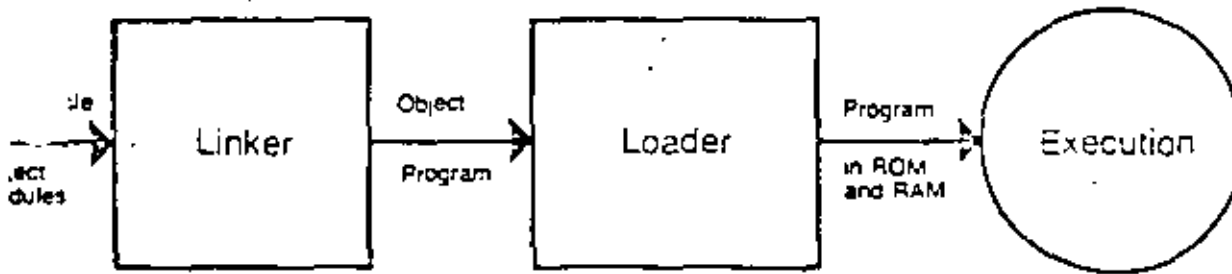

Language Program Steps

RETURN	Returns control from a subroutine
STOP	Transfers control to the END statement in the MAIN module
END	Terminates compilation and program execution
IF..THEN	Transfers control to a specified line or executes a specified statement when the result of the logical expression is true
IF..THEN..ELSE..	Transfers control to a specified line or executes a specified statement when the result of the logical expression is true. Otherwise, control transfers to the statement or line number following the keyword ELSE.
FOR..TO..STEP..NEXT	Executes a group of statements a specified number of times
OPEN	Associates a channel number with a physical device
CLOSE	Terminates all device associations with their specified channel numbers
RESTORE	Repositions a file back to the beginning of the information sequence
READ	Allows binary input from a specified file
INPUT	Allows ASCII input to an executing program from an external device or file
WRITE	Provides binary output to a specified file
PRINT	Provides ASCII output to an external device

SAMPLE PROGRAM: Program provides one function (TTYOUT) and one procedure (TTYINS); subroutines of a main 8002A MDU_μ Module

```

TEKTRONIX MCL 8080A-8085A Compiler
0001 REM * MODULE TO PROVIDE CONSOLE I/O SERVICE ROUTINES
0002 REM TO A TELETYPE INTERFACED THROUGH A MITS 88-SIOC
0003 REM THE INTERFACE IS ADDRESSED TO I/O PORTS 0-STATUS)
0004 REM AND I-DATA)
0005 REM THE OUTPUT ROUTINE IS PASSED A ONE CHARACTER STRING
0006 REM WHICH IS OUTPUT
0007 REM THE INPUT ROUTINE IS CALLED. IT RETURNS A ONE CHARACTER
0008 REM STRING AND ECHO'IS PERFORMED
0009
0010 MODULE TTYIO, MODE2
0020 PROVIDES FUNCTION TTYINS
0030 PROVIDES PROC TTYOUT
0040 USES PORT TSTAT, ORIGIN 0
0050 USES PORT TDATA, ORIGIN 1
0055
0060 TTY OUTPUT ROUTINE TO A MITS 88-SIOC INTERFACE
0065
0070 DEFPR TTYOUT: CATCH$=1
0080 IF (TSTAT AND 01H) > 0 THEN 80
0090 TDATA = CPRO(CATCH$)
0100 PREND
0105
0110 TTY INPUT ROUTINE FROM A MITS 88-SIOC INTERFACE
0115
0120 DEFEN TTYINS
0130 IF (TSTAT AND 080H) <> 0 THEN 130 * WAIT LOOP FOR
0135 * READY BIT
0140 * TO GO LOW
0150 TTYINS = CHR$(TDATA)
0160 FNEND
0165
0170 END
  
```

0 errors
0 warnings

MDU_μ SUPPLIED FUNCTIONS

ABS	Returns absolute value of numeric expression
SGN	Returns the sign value of numeric expression
STATUS	Returns status of value of I/O data
CHRS	Converts integer into corresponding ASCII character
STAS	Converts numeric expression into string value
VAL	Converts string into a numeric expression
ORD	Returns the ordinal position of a character in the ASCII sequence
LEN	Returns the number of characters in a string
POS	Searches for the occurrence of a string
TAB	Tabulates output to the specified column

MDU_μ SUPPLIED FUNCTIONS

^	Raises to the power of
*	Multiplies
/	Divides
MOD	Returns the remainder of a division
+	Adds
-	Subtracts
=	Is equal to
<	is less than
>	is greater than
<=	is less than or equal to
>=	is greater than or equal to
<>	is not equal to
NOT	Returns ones complement of an integer
AND	Returns logical AND of two integers
OR	Returns logical OR of two integers
XOR	Returns logical exclusive OR of two integers
ROR	Rotates right a specified number of bit positions
ROL	Rotates left a specified number of bit positions
SHR	Shifts right a specified number of bit positions
SHL	Shifts left a specified number of bit positions
&	String concatenation

MINIMUM HARDWARE REQUIREMENTS

Tektronix 8002A Microprocessor Lab with system terminal and 64K Program Memory
Emulator for 8080A, 8085A, Z80, or 6800 is required to debug and execute object code.

SOFTWARE PREREQUISITE

8080A, 8085A, Z80, or 6800 TEKDOS Version 3.0 software support is required.

Z80 GENERATED CODE CHARACTERISTICS

- Generated code does not use any of the Z80 extension capabilities over 8080A instruction sets
- Generated code does not use any index or alternate registers of the Z80.
- Generated code does not use alternate interrupt modes

SOFTWARE SUPPORT SERVICES

During the ninety (90) day period following installation of this Software Product (SOFTWARE), if the customer encounters a problem with the SOFTWARE which his diagnosis indicates is caused by a defect in the SOFTWARE, the customer may submit a Software Performance Report (SPR) to Tektronix. Tektronix will respond to problems reported in SPRs which are caused by defects in the current unaltered release of the SOFTWARE via the Maintenance Periodical for this SOFTWARE, which reports SPRs received, code corrections, temporary corrections, generally useful emergency bypasses and/or notices of the availability of corrected code. Software updates, if any, released by Tektronix during the ninety (90) day period, will be provided to the customer on Tektronix standard distribution media as specified in this Software Data Sheet. Charges will be based on the prevailing update price.

ORDERING INFORMATION

Option Description	Factory Price	Field Number	Field Price
8002A Microprocessor Lab			
Option 01 8080A Assembler Software Support		8002P01	
Option 1A MGL 8100/8085A Software Support (Requires 64K Program Memory & Option 01 or 03)		8002P1A	
Option 02 8080C Assembler Software Support		8002P02	
Option 2A MGL 6800 Software Support (Requires 64K Program Memory & Option 02)			
Option 03 6800 Assembler Software Support		8002P03	
Option 3A MGL 6800/6801 Software Support (Requires 64K Program Memory & Option 03)		8002P3A	
Option 04 8085A Assembler Software Support		8002P04	
Option 1A MGL 8080/8085A BASIC Software Support (Requires 64K Program Memory & Option 01 or 03)		8002P1A	

-The compiler generates 8080A assembly language. The output must be assembled with the 8080A assembler included in Option 01 and run on the Z80.

Prices in U.S.A., U.S.A. and Foreign Products of Tektronix, Inc., are delivered in U.S.A. and Foreign currencies and/or Regions Pending. All specifications subject to change without notice.

Tektronix
COMMITTED TO EXCELLENCE



Increased capabilities, architectural compatibility, and clearly defined interfaces were the chief architectural goals of Zilog's new Z8000 microprocessor family. Here is an account of how those goals were met for two members of that family—the Z8000 CPU and the MMU.

The Z8000 family is a new set of microprocessor components (CPU, CPU support chips, peripherals, and memories) which supports the Z8000 architecture. The account of how architectural goals were selected and achieved for two key members of this family—the Z8000 CPU and the memory management unit—illustrates how much of a challenge microprocessor architecture represents to the semiconductor industry. MOS technology shows enormous potential, but it is still difficult to use because of limitations on pin count, power dissipation, speed, and complexity.¹

Since this discussion is restricted to technical issues, we will not allude to the many additional factors (marketing considerations, human considerations, self-imposed restrictions, etc.) which make architecture such a fascinating and difficult discipline. Furthermore, no attempt has been made to exhaustively describe the Z8000 architecture and components. Interested readers should consult the specific manuals for a more complete description.^{2,3}

The goals of the Z8000 architecture: increased capabilities, architectural compatibility, increased clarity

The primary reason for introducing a new system architecture is to significantly improve the control and processing capabilities of microprocessors while maintaining their price/performance advantages. Technical advances have permitted the implementation of substantially increased processor power, but the most significant motivation for a new component family is generality. Only through such a family could we provide for architecturally compatible growth over a wide range of processing power requirements.

Our approach was a staged system architecture which attempts to provide new components, enhanced features, and new functions, while protecting the user's investment in hardware and software. The Z8000 family supports a single unified architecture for all small, medium, and high-end user applications which are implemented using a mix of components within the same family.

The goals of the Z8000 architecture can be grouped into three categories: increased capabilities, architectural compatibility over a wide range of processing powers, and increased clarity. In all these cases the resulting architectural features apply either to the basic architecture (that seen by an applications programmer) or to system architecture (that seen by a system designer or an operating system programmer).

Increased capabilities. All existing 8-bit microprocessors and many 16-bit minicomputers suffer from having a small address space. So, one of our goals was to provide access to a large address space (8M bytes). A second goal was to provide more resources in terms of registers (16 general-purpose 16-bit registers), in terms of data types (from bits to 32 bits), and in terms of additional instructions compared to existing microprocessors (multiply and divide, multiple register saving instructions, specialized instructions for compiler support etc.).

To facilitate complex applications it was important to support multiprogramming with good hardware support of task switching, interrupts, traps, and two execution modes. Operating systems also required a good hardware protection system.

Finally, we wanted to increase overall system performance. This resulted in the choice of an implementation using a 16-bit-wide data path to memory.

Architectural compatibility. One of the important lessons learned from previous computer system designs is that the design of a new family architecture is a rare occurrence. One way to apply this lesson is to design a unified architecture compatible over a wide range of processing powers. If we anticipate user growth from small to large systems within a family architecture, then such an approach can significantly increase its life.

The two versions of the Z8000 (a 40-pin unsegmented and a 48-pin segmented version) are designed to achieve this goal, but many other features contribute indirectly to the family compatibility. For small applications an unsegmented Z8000 with one or more 64K-byte address spaces can be used. For medium applications, a segmented Z8000 and one memory management unit allows direct access to 4M bytes of address space. For large applications a segmented Z8000 and multiple pairs of MMUs allow the use of several 6M-byte address spaces.

Since the segmented Z8000 can run in an unsegmented mode, both systems are compatible. Finally, to achieve even larger processing power through hardware replication, the architecture provides basic mechanisms for both multiprocessing and distributed processing.

Clarity. Clarity in an architecture is a measure of how well key interfaces are defined and specified. This is an elusive but important goal in a family where new and unforeseen components will be added during the life of its architecture.

We felt bus protocols were so important that we developed an independent specification for the Z-bus along with the individual device manuals.

Clarity in terms of the basic architecture means regularity and extendability of the instruction set, as well as the general and simple handling of the operating system interfaces. Clarity in terms of the system architecture means a well defined method of communication between the various components. The key link between these components is the Z-bus, which is a shared system bus. In the section on communication with other devices, we describe some of the various types of bus protocols. At Zilog we felt this was so important that we developed an independent specification for the Z-bus along with the individual device manuals.

Comparison with other system architectures

We are convinced that the differences between microprocessor system architecture and large computer system architecture are not sufficient to re-

quire a different design approach, although they certainly influence the details of design compromises. The last section of this paper deals with implementation tradeoffs and illustrates some particular compromises. (In a few places we mix implementation considerations with descriptions of architectural tradeoffs. Despite the importance of separating an architecture from its implementation, we found that this separation is often absent during the actual creation of a new architecture.)

Two differences between conventional computer systems and microprocessor systems have the greatest impact: price structure and component boundary differences. For high-end LSI systems, it makes sense to have one unified architecture, but unlike their computer family counterparts (IBM 360/370, PDP-11) different implementations cannot be justified on a price/performance basis. Speed and performance are mainly dependent on the state of technology, and therefore, for a given application, a user will waste the speed willingly since another slower implementation would cost the same. This does not exclude different versions of one implementation, which reflect only different test and production criteria such as package type, functional temperature range, and even speed range.

Most computer systems have both external and internal interfaces. External interfaces which define system boundaries are often standardized (e.g., the IBM channel interface or the DEC unibus). The internal interfaces of most mini or large computer systems are essentially hidden. In contrast, the component boundaries of a microprocessor-based system represent actual interfaces, and most users must be familiar with them as well as with external interfaces. Because the component interfaces are more visible and often must be more general, the microprocessor-oriented system bus emerges as a key standardization link to allow a wider mix of components and designs.

The basic architecture

Address space considerations. It is advantageous to have more than one address space, with each address space as large as possible. In the Z8000, memory references and I/O references are viewed as references to different address spaces. The I/O space is discussed in the section below on communication with other devices. Memory references may be instructions or data and stack accesses, with each type of access possible in either system or normal modes. The Z8000 distinguishes between each of these reference possibilities by using different combinations of its status lines. Separating the various address spaces can be used to increase the total number of addressable bytes and to achieve protection. The size of each address space depends on the versions of the Z8000 used. The 40 pin package version allows each address space to be at most 64K bytes, the 48-pin package version allows each address space to be at most 500K bytes.

The 40-pin version is intended for systems, often used as dedicated systems, where the program and data spaces are small. In this case, relocation is not usually important. Using the different address spaces, one has a simple way to address in practice up to 4 x 64K bytes (with a maximum of 6 x 64K bytes). Some simple protection is achieved by separating these spaces in hardware.

The 48-pin version with one or more MMUs is intended for the medium to large applications where relocation and better memory protection are important.³ In these cases, status information can also be used to separate between address spaces by using multiple MMUs. But it is also essential to achieve the detailed memory protection required. (It is possible to use the 48-pin version without an MMU.) For these high-end applications, the address spaces are so large that one is unlikely to exhaust them. Experience with large computers shows that 8M bytes is probably adequate. The current implementation of the Z8000 uses 8M-byte address spaces, but the architecture provides for 31-bit address (2147M bytes).

In both versions, the Z8000 allows direct access to each address space. Direct access means that the addresses used in instructions or registers have as many bits as the address space size requires. In other schemes the effective address is a combination of a shorter field in the instruction and other extension bits often found in an implied register. Despite the shorter address fields, we believe this "indirect access" does not save bytes, because extra instructions must be used to load and save the implied registers, which are typically in short supply.

Registers. The Z8000 is primarily a memory-to-register architecture. This characteristic does not entirely exclude other organizations, and mechanisms exist in the Z8000 to support them. For example, memory-to-memory operations are supported for strings, whereas stack operations are supported for procedure and process changes. This choice provides upward compatibility with the Z80. A register architecture also results in good performance, since register accesses are made at a greater speed than memory accesses in the current implementation.

Experience with register-oriented machines seems to confirm that four general-purpose registers are not enough and that a "proper" number is between eight and 32.⁴ The Z8000 supports bytes, words (16-bit), and long words (32-bit), and a few instructions even use quadruple-word (64-bit) data elements. If we choose 16, 16-bit registers allow eight 32-bit registers as well as four 64-bit registers (Figure 1). Since addresses are 32 bits, the necessity of at least eight 32-bit registers was obvious. The impact of the 4-bit register field on the instruction format depends also on the number of address modes and operands. Sixteen registers allowed a reasonable tradeoff, whereas 32 registers would have resulted in too few one-word instructions.

With one minor restriction any register can be used by any instruction as an accumulator, source operand, index, or memory pointer. This regularity of

the structure is so important that it is worthwhile to sacrifice any possible encoding improvements in instruction formats which could result from dedicating registers to special functions. Encoding improvements based on instruction frequency, so that frequent instructions use one word, are more effective in saving space without having a negative effect on the architecture.

Why not have specialized registers? The difficulty lies in the fact that the restrictions caused by dedication are inconsistent with one another.

Most applications dedicate the available registers to specific functions. For example, most high-level languages require a stack pointer and a stack frame pointer. Then why not, one might argue, have specialized registers? The difficulty lies in the fact that the restrictions caused by dedication are inconsistent with one another. If the architecture supplies only general-purpose registers, the user is free to dedicate them to specific usages for his application without restrictions. This is important in the context of microprocessors where user applications are not well known and where high-level languages are still used infrequently.

For example, the Z8000 allows software stacks to be implemented with any register. There are also two hardware supported stacks, but the registers used are still general-purpose and can participate in any operation. There is no allocated stack frame pointer, since any register can be used by means of the proper combination of addressing modes. The savings realized by register specialization are unattractive when the given function can still be performed simply. The loss that would result from restricting the applications would be too great. In contrast, significant savings result from excluding R0 from use as an index or memory pointer. This exclusion allows one to distinguish between the indexed and direct addressing modes which use the same combination of the instruction address mode field. The price is small, since R0 still can be an accumulator or source register and 15 others accumulator, index, and/or memory pointers are available. In this case the restriction made sense.

Another decision to be made about registers is their size. Since the architecture handles multiple data types we must have multiple data register sizes, which can hold each data type. The solution of the problem is implemented in the architecture by pairing registers, two 1-byte registers make a word register, two word registers make a long word register, etc.

Data types. Users would like to have as many directly implemented data types as possible. A data type is supported when it has a hardware representa-

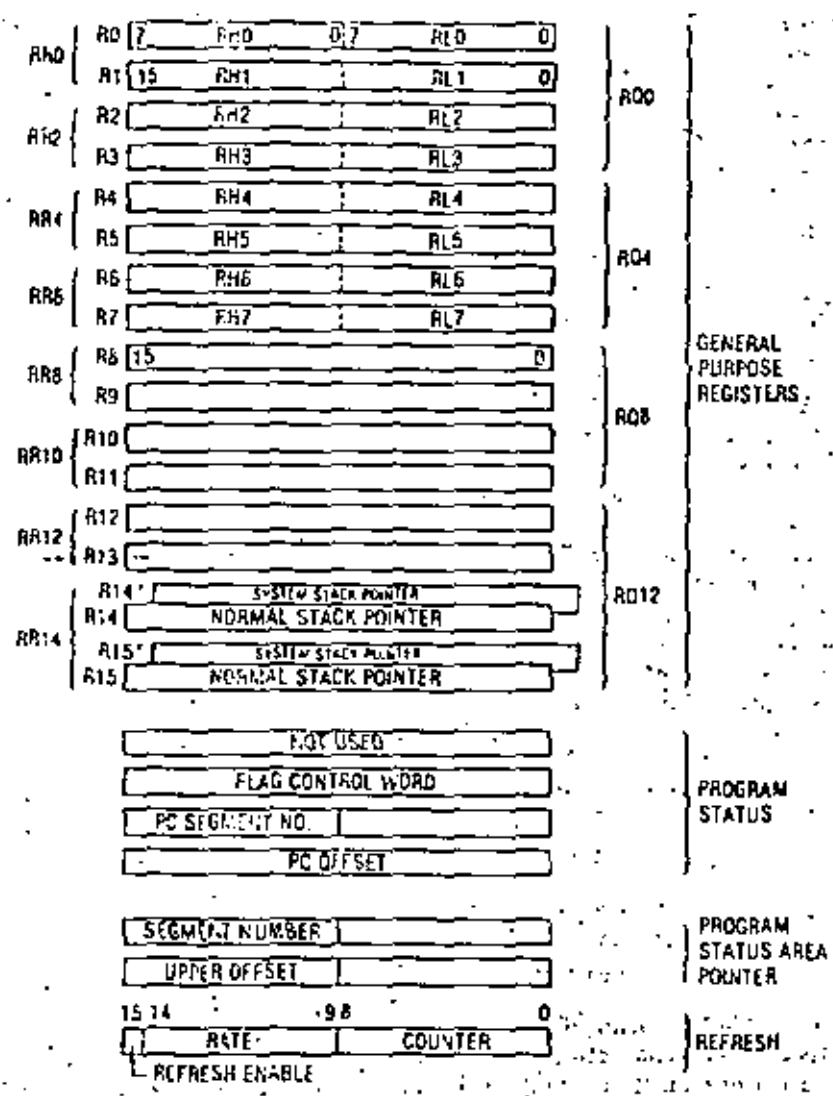

Figure 1. CPU registers (segmented version).

tion and instructions which directly apply to it. New data types can always be simulated in terms of basic data types, but hardware support provides faster and more convenient operations. At the same time, a proliferation of fully supported data types complicates the architecture and the implementations.

The Z8000 supports several primitive types in the architecture and provides expansion mechanisms. The basic data types are obviously the ones expected to be used most frequently. The extended data types are built using existing data types and manipulated using existing instructions.

The basic data type is the byte, which is also the basic addressable element. All other data types are referenced using their first byte address and their length in bytes. The architecture also supports the following data types: bytes (8 bits), words (16 bits), long words (32 bits), bytes, and word strings. In addition, bits are fully supported and addressed by number within a byte or word. BCD digits are supported and represented as two 4-bit digits in 1 byte. One consequence of this data type organization is that byte, word, and long-word registers are needed

to support them. The Z8000 even provides quadruple register—another extension—used in long-word manipulation.

Other data types are supported by using one of the preceding data types; for example, addresses are manipulated as long words, and each element (segment number or offset) can be manipulated as a byte or a word. Instructions are one to five word strings, the program status is four words, etc.

As the family grows, support for new data types will be added. The architecture will need to support them in its registers or in memory if they do not fit in registers (as strings are implemented today). But most important, the architecture will have to support the addition of new instructions to its repertoire.

Instructions. In designing an instruction format the architect must decide how to allocate a limited number of bits to the opcode field, address mode field, and other operand subfields. Instruction usage statistics are the best source of data to influence decisions about instruction set format.^{1,4,7} Behind their usage lies a strong technical position: we do not

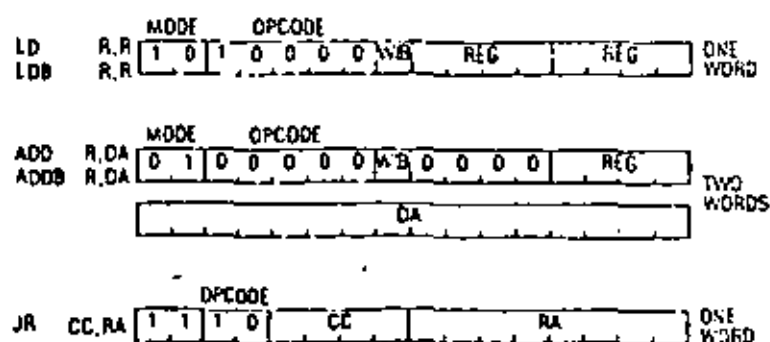

Figure 2. Examples of instruction formats (nonsegmented version).

believe that any one of the various instruction set structures—register oriented, memory oriented, stack oriented, symmetrical, or asymmetrical, etc.—are always better when used exclusively. Thus the task of the architect is to decide what his most important goals are, and for each of them adapt the best features of the various structures so that on the average, and for his set of goals, an optimum solution can be found. We do not believe that the optimum will be very sharp; it will be more like a range of applications for which the resulting composite structure works well. We decided to use a register structure for compatibility, multiple word instructions for speed, memory-to-memory instructions for strings, stack structure for process control and procedure support, "short" instruction for byte density improvement, etc.

Instruction format consideration. The Z8000 has over 110 distinct instruction types; several instruction formats are illustrated in Figure 2. The opcode field specifies the type of instruction (for example, ADD and LD). The mode field indicates the addressing modes (for example, Register (R), Direct Address (DA)). The data element type (W/B) and register designator fields complete the basic instruction fields. Long word instructions use a different opcode value from their byte or word counterpart. Frequent instructions are encoded in a single word, and less frequent instructions—which use more than two operands use two words. There are often additional fields for special elements such as immediate values or condition code descriptors (CC). Instructions can designate one, two, or three operands explicitly. The instruction TRANSLATE AND TEST is the only one with four operands and is also the only one with an implied register operand.

Several restraints can guide the proper choice of an instruction format. A large number of opcodes (used or reserved) is very important: having a given instruction implemented in hardware saves bytes and improves speed. But one usually needs to concentrate more on the completeness of the operations available on a particular data type rather than on adding more and more esoteric instructions which, if used frequently, will not significantly affect performance. Great care must be given to the problem of expanding the instruction set so, for example, new data types can be added.

Addressing modes. The Z8000 has eight addressing modes: register (R), indirect register (IR), direct address (DA), indexed (X), immediate (IM), base address (BA), base indexed (BX), and relative address (RA). Several other addressing modes are implied by specific instructions such as autoincrement or auto-decrement.

Although a very large number of addressing modes is beneficial, usage statistics demonstrate that not all combinations of operands, address modes, and operators are meaningful. The five basic addressing modes of R, IR, DA, X, and IM are the most frequently used and apply to most instructions with more than one address mode. For two-operand instructions, statistics show that most of the time the destination is a register. Other cases of addressing mode combinations and less basic addressing modes are associated with special instructions. Thus, the frequent combination of auto-decrement for the destination operand with the five basic address modes for the source operand is provided by the PUSH instruction. The combination of auto-increment addressing modes for both source and destination operands is one of the block move instructions. In essence, the address mode field space has been traded for opcode field space. This allows more instructions and combinations while staying within a one-word format.

The price for this tradeoff is the infrequent occurrence of pairs or triples of instructions simulating a missing addressing mode. This situation occurs in most instruction sets in any case.

Code density. Because current microprocessors are restricted to primitive pipeline structures, their speed is largely dependent on the number of executed instruction words. Therefore, code density is not only important because of program size reduction but also because of speed improvement. One would like to encode in the smallest number of bits the most frequent instructions. The basic instruction size increment was chosen to be a word for reasons dealing with alignment, speed penalties, and hardware complexity. Thus the most frequent one and two operand instructions take one word in their register or register-to-register forms. Less frequent instructions or instructions which use more than two operands use at least two words.

The Z8000 goes even further by selecting several special instructions as "short" instructions which take only one word, when normally they would take two words. These instructions, such as LOAD FROM REGISTER IMMEDIATE and LOAD FROM REGISTER IMMEDIATE (for small immediate values), CALL RELATIVE, and JUMP RELATIVE, are so frequent that finally they deserve such special treatment.

A one word JUMP RELATIVE and DECREMENT AND JUMP ON NON ZERO also have a very significant impact on speed. The short offset mechanism used by addresses (and described below) is also designed to allow one word addresses. Compared to previous microprocessors, the largest reduction in size and increase in speed results from the Z8000's consistent

and regular structure of the architecture and from its more powerful instruction set—which allows fewer instructions to accomplish a given task.

High-level language support. For microprocessor users, the transition from assembly language to high-level languages will allow greater freedom from architectural dependency and will improve ease of programming.⁸ It is easy and tempting to adapt a computer architecture to execute a particular high-level language efficiently.⁹ Most programming languages act as a filter and can be supported by a subset of available hardware with greater efficiency.¹⁰ But efficiency for one particular high-level language is likely to lead to inefficiency for unrelated languages. The Z8000 will be used in a wide variety of applications, and we know that a large number of users will still be using assembly languages. Since the Z8000 is a general-purpose microprocessor, language support has been provided only through the inclusion of features designed to minimize typical compilation and code-generation problems. Among these is the regularity of the Z8000 addressing modes and data types. The addressing structure provided by segmentation should support procedures that result from structured programming. Access to parameters and local variables on the procedure stack is supported by index with short offset address mode as well as base address and base indexed address modes. In addition, address arithmetic is aided by the INCREMENT BY 1 TO 6 and DECREMENT BY 1 TO 16 instructions.

Testing of data, logical evaluation, initialization, and comparison of data are made possible by the instructions TEST, TEST CONDITION CODES, LOAD IMMEDIATE INTO MEMORY, and COMPARE IMMEDIATE WITH MEMORY. Compilers and assemblers manipulate character strings frequently, and the instructions TRANSLATE, TRANSLATE AND TEST, BLOCK COMPARE, and COMPARE STRING all result in dramatic speed improvements over software simulations of these important tasks, especially for certain types of languages. In addition, any register can be used as a stack pointer by the PUSH and POP instructions.

Segmentation. In order to provide for convenient code generation and data access, addresses must also be easy to manipulate. Architectures with direct access to memory typically use a linear address space, so that address arithmetic may be used on the entire address. In this case, addresses are manipulated as one of the data types of the same size. This removes the need to distinguish an address as a new data type. In contrast, the Z8000 has a non-linear address space. Addresses are made of two parts: a 7-bit segment number and a 16-bit offset. Only the offset participates in address arithmetic. The segment number is essentially a pointer to a part of the total address space, which can vary in size from 0 to 64K bytes. The hardware representation of a segmented address is a long word or a register pair (Figure 3), which allows the easy manipulation of each part of the address.

The segmented addresses are one of the key mechanisms used to support both large and small

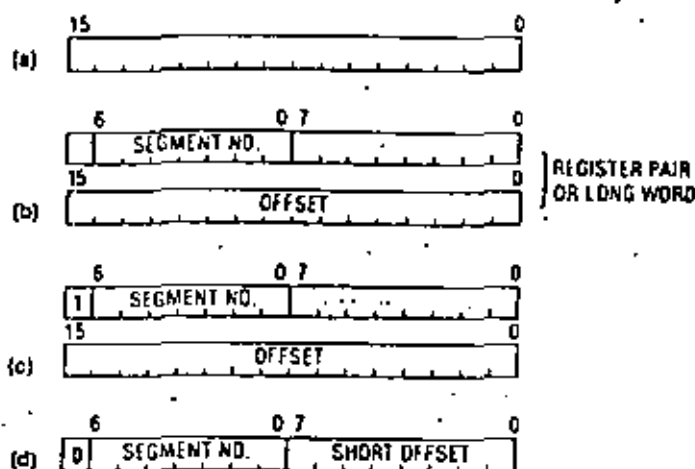

Figure 3. Hardware representation of segmented addresses. Any non-segmented address is one word, whether it is in a register, memory, or an instruction (Figure 3a). Segmented addresses are always two words in a register or memory (Figure 3b); however, instructions can have one of two forms. The usual case (long offset) requires two words (Figure 3c); however, there is also a short offset form that uses only one word (Figure 3d).

memory systems efficiently. The two versions of the Z8000 implementation, the 40-pin unsegmented and the 48-pin segmented, allow the maintenance of the architectural compatibility and ease the growth between these two application groups. The segmented address space guarantees that each 64K-byte address space of the 40-pin version becomes one of the segments of the 48-pin version. Each 40-pin version's 16-bit address becomes an offset within the segment, and a mode exists in the 48-pin package version in which 40-pin version code can be executed. Furthermore, compatibility with any current 8-bit microprocessor such as the Z80 is easy, and a new microcomputer such as the Z8 can address external data in a shared segment with the Z8000.

The hardware performance of the Z8000 is also improved by address segmentation. Since a segment number does not participate in arithmetic, it can be put on the bus before the result of an address computation is available. This feature allows the use of MMUs with essentially no impact on memory access time by allowing it to function in parallel with the CPU. Indexing operations are also faster because only a 16-bit addition must be performed. Because of the distinction between the segment number and its offset, one can use shorter addresses without software constraints. Short addresses can use a short offset (fewer than 256 bytes) and thereby reduce program size (Figure 3).

Finally, it is very easy to associate with each of the 128 segments of the address space the protection and dynamic relocation features desirable for larger systems. Relocation allows a user to write his application using logical addresses independent of any physical addresses. Relocation is essential, for example, in a disk-based general data processing system with several users. Relocation is not essential for dedicated applications with code typically residing in

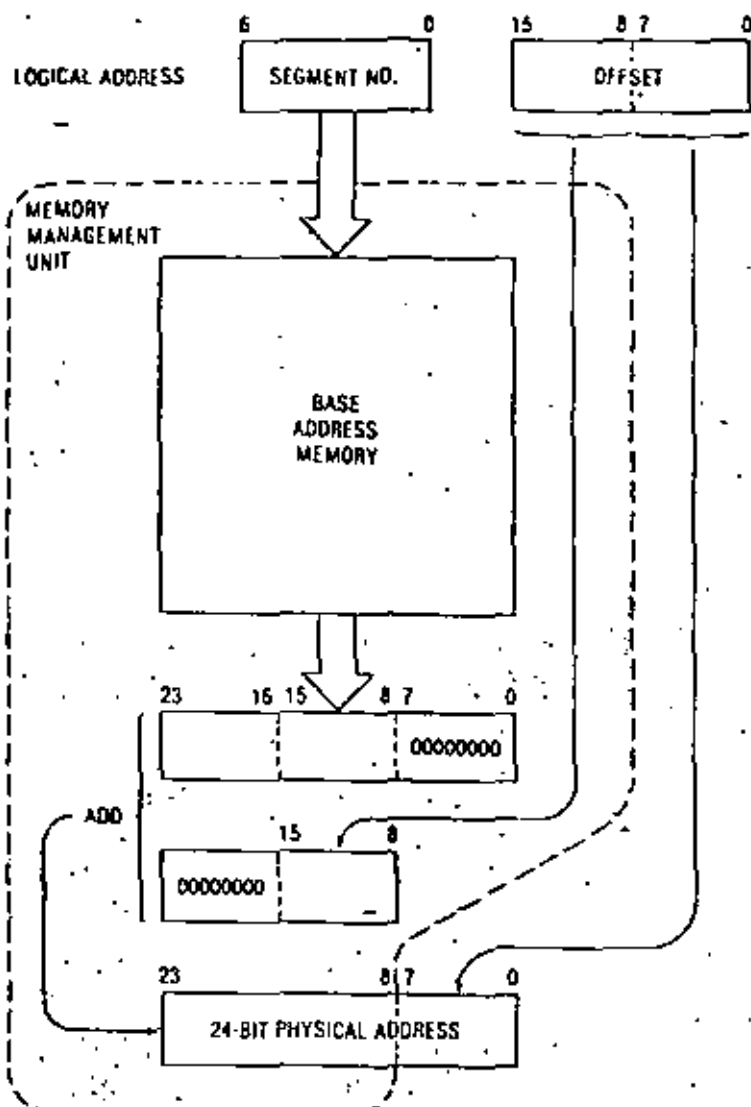

Figure 4. Logical to physical address translation.

ROM. Users whose total memory needs are small are also unlikely to need relocation.

In summary, the choice of a segmented address space has provided—at low cost and with few practical limitations—a powerful solution to the problem of user growth, relocation, and protection as well as virtual memory implementation. We believe that a linear address space could have achieved these results but at a considerably higher price.

The system architecture

Protection facilities. The Z8000 protection facilities can be divided into system protection features and memory protection features. Experience with large computers has demonstrated the advantages of having at least two execution modes with different access rights to hardware facilities. The Z8000 provides the system and normal modes for this purpose. A simple protection system results from the presence of these two modes and their

associated stacks. A special class of "privileged" instructions is defined, which deals with I/O, interrupts, traps, and mode changes. Programs in normal mode which attempt to execute a privileged instruction will cause a trap and a change to system mode. The switch from user to system mode can also be caused by the system call instruction. These mechanisms enforce protection and help in designing reliable and efficient operating systems with clean user interfaces. Several other traps are required to achieve a consistent system: segmentation trap, privileged instruction trap, and undefined instruction trap.

A desirable memory protection scheme is one for which protection information (read only, read write, execute only, system only, size of data or code, etc.) is easily associated with the data and code structures of a given application. It is also one for which a large number of different types of protection information can be verified.

The relocation and memory protection mechanisms described above are provided by an external device: the memory management unit. To provide relocation and protection features directly on the Z8000 would have demanded too much simplification. The external MMU has the further advantage of providing for easier growth by the addition of components. The Z8000 40-pin package does not have to carry the burden of the unused advanced relocation and protection features, although some form of protection can be achieved by hardware separation of the different address spaces. With multiple MMUs, the 48-pin package user can control the relocation and protection complexity desired in his application.

The memory management unit. The MMU performs three functions: (1) address translation of logical address to physical address using dynamic relocation, (2) memory protection, and (3) segment management. The addresses manipulated by the programmer, used by the instructions, and output by the Z8000 are called logical addresses. The MMU uses these logical addresses, composed of a 7-bit segment number and 16-bit offset, and transforms them into a 24-bit physical address (Figure 4). A 24-bit origin or base is logically associated with each segment. To form a 24-bit physical address, the 16-bit offset is added to the base for the given segment. In effect, with the help of one memory management device, the Z8000 can address 8M bytes directly within a 16M-byte physical memory space. The reasons for the choice of a large physical address space include an expectation that large systems will want to use extra bits for complex resource management purposes.

Each segment is given a number of attributes when it is initially entered into the MMU. When a memory reference is made, the protection mechanism checks these attributes against the status information from the CPU. If a mismatch occurs, a trap is generated which interrupts the CPU. The CPU can then check the MMU status registers to determine the cause of the trap. Segment attributes include segment size and type (read only, system only, execute only, in-

valid DMA, invalid CPU, etc.) Other segment protection features include a write warning zone useful for stack operations.

When a memory protection violation is detected, a write inhibit line guarantees that memory will not be incorrectly changed. The invalid DMA and CPU bits indicate that the entry cannot be used by the DMA or CPU respectively, because either the segment number is illegal or the segment entry is not loaded. This fast feature, in conjunction with the segment history information (segment "changed" and segment "referenced" bits) and the segmentation trap mechanism, allows the implementation of a virtual segmented memory system.

The MMU comes in a 48-pin package (Figure 5). The chip inputs are the segment number, the upper 8 bits of the offset, and status information from the CPU. The outputs from the segment chip are the upper 16 bits of the 24-bit physical address and the segmentation trap line. Since the memory management device processes only the upper 8 bits of the offset, the lower 8 bits go directly to memory. This is equivalent to having zeros in the 8 lower bits of the 24-bit origin. Thus, the memory management device only needs to store the upper 16 bits of each base address. Segment limit protection is done in the memory management device, and thus segments can be protected in increments of 256 bytes.

Each MMU stores 64 segment entries that consist of the segment base address, its attributes, size, and status. A pair of MMUs support the 128 segments available in an address space. Additional MMUs can be used to accommodate multiple translation tables. Using the status information provided with each reference, pairs of MMUs can be enabled dynamically.

The memory management device functions constantly while memory references are made, but its translation and protection tables are loaded and unloaded as an I/O peripheral. To achieve this, the memory management device has chip select, address strobe, data strobe, and read/write lines. The Z8000 special byte I/O instructions that use the upper byte of the data bus can load or unload the memory management device.

Mode switching: interrupt and trap handling. From small users in dedicated process control applications to large users in general-purpose data processing applications, asynchronous events such as interrupts and synchronous events like traps must be handled. When these events occur, the state of any currently executing program must be saved during what is generally called a task switch or process switch. The users benefit from the availability of many interrupts and traps. They also benefit from a fast, easy, and uniform handling of process switching.

Peripherals using interrupts have widely varying constraints on interrupt processing limit. To solve this problem, peripherals with the same characteristics are often associated with one of several interrupts. A priority enforced among the several interrupts allows the required processing time to be

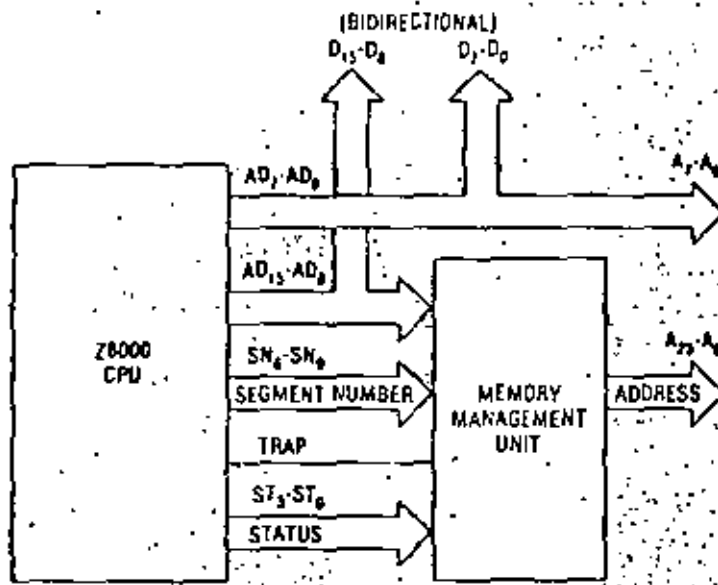

Figure 5. Memory management device with Z8000 CPU.

guaranteed. Enabling or disabling the various interrupts is the mechanism used to enforce this processing priority.

In the Z8000, we felt that three levels of interrupts were sufficient. A *non-maskable interrupt* represents a catastrophic event which requires special handling to preserve system integrity. In addition there are two maskable interrupts: *non-vectorred interrupts* and *vectorred interrupts*, which correspond to a fixed mapping of interrupt processing routines and to a variable mapping of interrupt processing routines depending on the vector presented by the peripheral to the Z8000.

Both interrupts and traps result in similar process switches. Information related to the old process (its program status) is saved on a special system stack with a code describing the reason for the switch. This allows recursive task switches to occur while leaving the normal stack undisturbed by system information. The state of the new process (its new program status) is loaded from a special area in memory—the program status area—designated by a pointer resident in the CPU (see Figure 6).

The use of the stack and of a pointer to the program status area are specific choices made to allow architectural compatibility if new interrupts or traps are added to the architecture. The choice of the two modes of execution has a strong impact on the design of clean user interfaces. Experience has shown that in large systems the normal mode instruction set and the user interfaces together constitute the most important element in achieving architectural compatibility.

Communication with other devices: the Z-bus. The Z-bus is the shared bus which links all the components of the Z8000 family. The variety and performance requirements of the components are so different that in fact the Z-bus is composed of five buses:

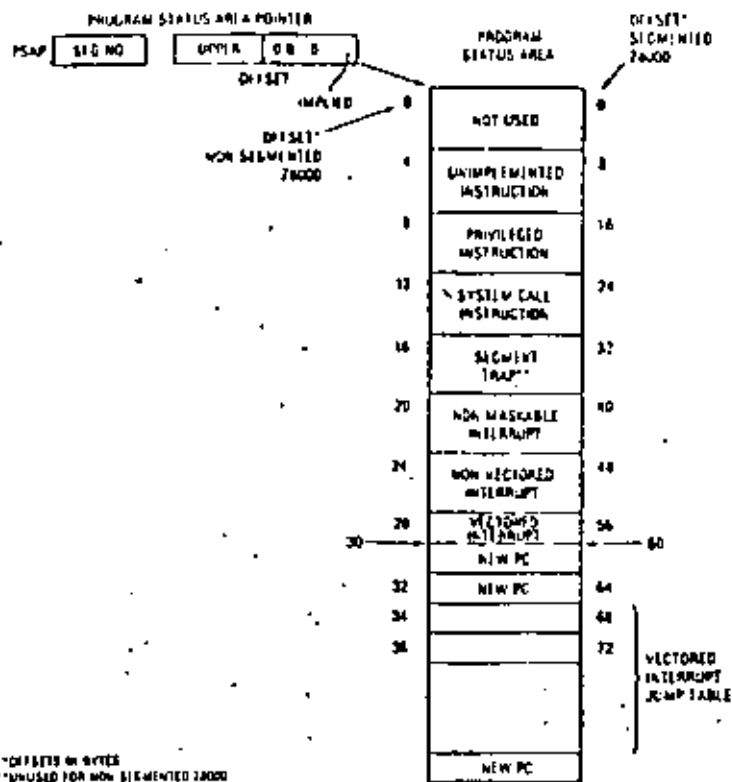

Figure 6. Program status area.

a memory bus, an I/O bus, an interrupt bus, and two resource request buses (Figure 7).

The Z-bus is called a "shared" bus because several components can use it. A bus user is a CPU or a peripheral which can usually generate one or more bus transactions such as memory data request or an I/O request. Identical bus transactions cannot take place at the same time, but serialization mechanisms allow sequential use of the Z-bus. Architecturally, the buses can be grouped into two structures. The I/O structure uses the I/O bus and the interrupt bus. The memory structure uses the memory bus with or without address extensions. Both structures can use the resource request bus and the mastership request bus.

Each bus consists of a set of signals and the protocols which preside over the various types of transactions. Part of each protocol is the timing relationship between relevant signals. The Z8000 CPU provides most of these timing relations. The advantage of such a choice is the significant reduction in the number of components required to build such a system. One consequence is that bus transactions cannot be aborted or delayed freely since some devices, especially memory, have specific timing constraints. The most important consideration for the Z-bus is the need to interface to multiplexed address and data lines of the Z8000 CPU which must fit in 40- and 48-pin packages. The Z-bus maintains these multiplexed address and data lines. Very little speed could be gained by demultiplexing these lines for memory references since memories are themselves multiplexed. The most important advantage of a multiplexed Z-bus is the direct addressability of

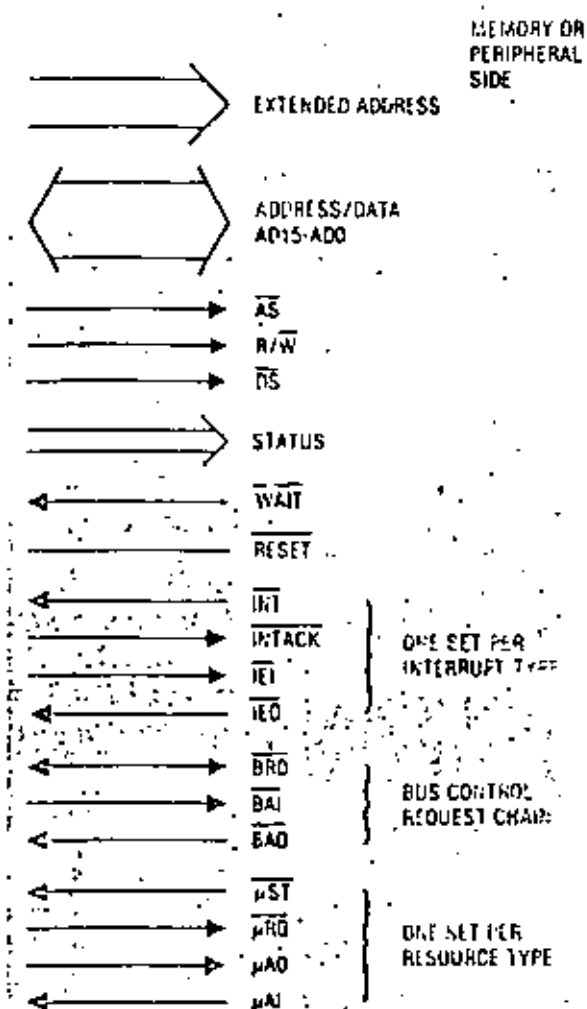

Figure 7. Z-bus signals.

peripheral internal registers. This feature allows the construction of complex peripherals which maintain a simple program interface.

The Z-bus is known as a transparent or asynchronous bus. Z8000 components do not require that their clocks be synchronized with the CPU clock. The signals used by each transaction provide all the necessary timing. This concept is important; it allows, for example, I/O references to be independent of the speed and clock frequencies required by other Z-bus transactions.

I/O bus versus memory bus: The I/O and memory buses are the most important. The Z8000 family architecture distinguishes between memory and I/O spaces and thus requires specific I/O instructions. This architectural separation allows better protection and has a nicer potential for extension. The I/O and memory buses use a 16-bit address/data bus which allows 16-bit I/O addresses and 8- or 16-bit data elements. Memory addresses are 16 bits for the 40-pin package or extended to 23 bits using the segmented version. Thus, the memory bus is in fact a logical address bus. The increased speed requirements of future microprocessors is likely to be achieved by separating memory and I/O references to their

respective characteristic reference patterns and by using simultaneous I/O and memory referencing. These future possibilities require an architectural reparation today. Memory-mapped I/O is still possible, but we feel the loss of protection and potential expandability are too severe to justify memory-mapped I/O by itself.

Both the I/O and memory buses need address, data, and control signals. One important implementation decision was to overlap the signals used by the memory and I/O buses on the same Z8000 CPU pins, with the obvious exception of the status signals used to distinguish between the two types of bus requests. For the current Z8000 implementation the resulting reduction in number of pins is significant. In contrast the impossibility of doing concurrent memory and I/O referencing is not very significant since their speeds are essentially the same.

In addition, memories and peripherals both benefit from the availability of early status information defining the bus transaction type (I/O versus memory, read versus write) ahead of the actual transaction so that bidirectional drivers and other hardware elements can be enabled before the reference. The status lines of the Z8000 CPU provide this type of early status.

The I/O structure. Since many peripherals are connected with one CPU, the I/O bus is shared and serialization must be provided. One solution involves using a master/slave protocol. The CPU is a master which can initiate an I/O transaction at any time. The peripherals are slaves which participate in a transaction only when requested by the master. In order to find out if a peripheral needs to be serviced the master can poll each in turn. The Z-bus also provides a faster way of getting the attention of a master; an interrupt bus. In contrast, with the I/O transaction data bus, each peripheral sharing the interrupt bus may "try" to use it simultaneously. The interrupt bus uses an interrupt line, interrupt acknowledge line, and two more lines used to form a daisy chain. The daisy chain is an implementation of a distributed arbitration policy between the requests. Priority of processing is determined by the position in the daisy chain, and peripherals can be preempted. Interrupt vectors are used to determine the identity of the peripherals requesting service via an interrupt.

Other buses. The two resource request buses are used to request the control of the Z-bus from the CPU and to request control of any generalized resource.

The Z8000 CPU or any Z-bus compatible CPU does not need to request the bus to access it as a master, and is, therefore, the default master. Other devices can request bus mastership, but they must go through a non-preemptive distributed arbitration using another daisy chain. The CPU always relinquishes the bus at the end of its current bus transaction.

The resource request chain is a generalization of that concept in which each resource requestor has equal importance and can use the resource in a non-preemptive manner. This mechanism in the Z8000 CPU permits one to implement in software the kind

of exclusion and serialization mechanisms needed for multiple distributed systems with critical resource sharing.

Multiprocessing. In the context of today's large mainframe systems characterized by multiple processes sharing one processor, one is tempted to design distributed processing systems with many low-cost microprocessors running dedicated processes. Such an approach distributes intelligence towards the peripherals, results in modularization, and permits easier development and growth. Unfortunately, in the past, the problem with such an approach has been software and not hardware. Thus one cannot be expected to provide detailed solutions in hardware to a software problem that has not been solved yet. However, some basic mechanisms have been provided to allow the sharing of address spaces; large segmented address spaces and the external MMU make this possible, and a resource request bus is provided which in conjunction with software provides the exclusion and serialization control of shared critical resources. These mechanisms and new peripherals like the Z-FIO have been designed to allow easy asynchronous communication between different CPUs.

Implementation tradeoffs

The key family decision: producibility. Confronted with the problem of designing a new LSI-based system architecture, we could have ignored package size considerations by accepting packages with 64 or more pins, or we could have ignored mass production technology constraints by using die sizes larger than 260 mils square. Such solutions are often justified in the implementation of an existing computer system. The component boundaries, package limitations, and technological limitations are secondary to achieving the goal of exact membership in the computer family. But if one were to design a new system architecture with the same lack of constraints, the individual component would not be price-competitive—only the total system would be. A new system architecture based on this approach could only be used to design yet another traditional computer.

The Z8000 family provides basic, general-purpose blocks out of which a system solution to most problems can be implemented.

The Z8000 family market is intended to be much broader, and each component of the family must be economically viable. The staged introduction of components which are economically viable by themselves allows us to serve the market from very small configurations to very large configurations by using more components, in any combination. Not only do we believe that this approach does not restrict

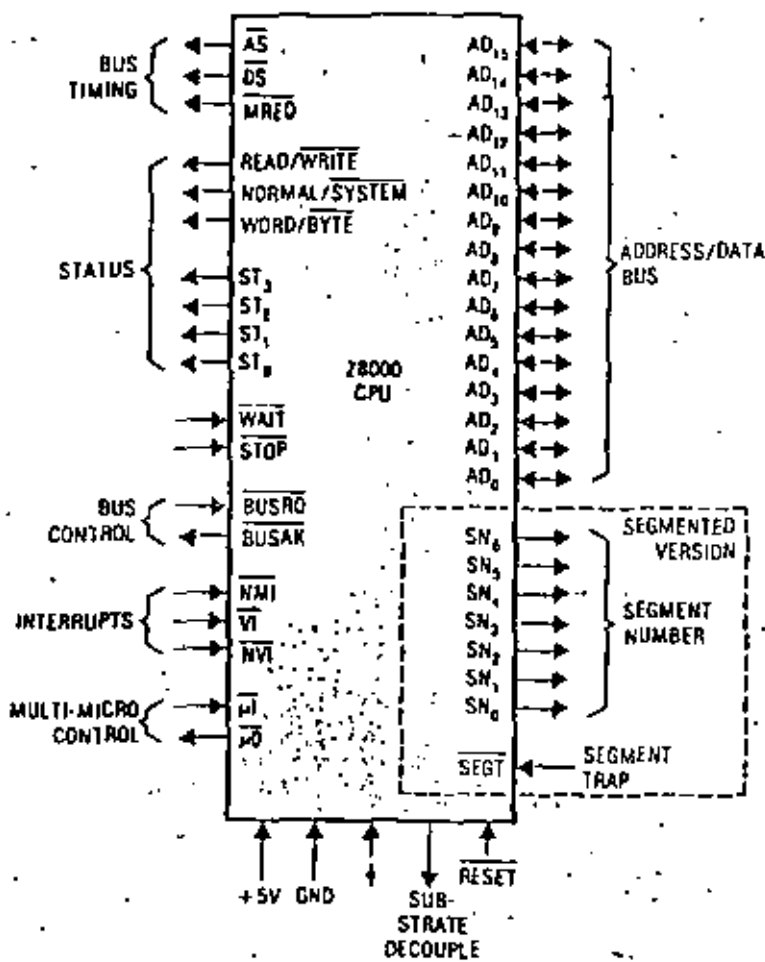

Figure 8. Z8000 pin functions.

system architectural possibilities, but we also believe that the family will be more effective because it will grow with its customer.

The Z8000 family does not always attempt to provide specific architectural solutions, often implemented in hardware, to all system architecture problems. Instead, it provides basic, general-purpose blocks out of which a system solution to most problems can be implemented. The multi-microprocessor and distributed system capabilities of the Z8000 family illustrate the use of open-ended mechanisms to solve a variety of architectural problems, while the memory management of address space illustrates a specific problem supported by a specific solution—the MMU. However, other solutions more appropriate to a particular problem can be used and an advance in the state of the art might be mapped into a new device for the family.

This vision of the family often results in components more powerful and complex than an application may require. The user should not take this as a cause for alarm, but rather as the reason his applications growth will be easier.

Basic CPU implementation decisions. The Z8000 currently uses a 16-bit data bus (Figure 8), an internal register array of 16-bit registers, and a 16-bit parallel

ALU. These implementation decisions, which were guided by the technological and practical considerations, have a strong impact on performance.

To achieve good performance with the instruction format and data type envisioned for the Z8000, only a 16-bit bus seems adequate, a 32-bit bus would have necessitated using an unacceptable 56-pin or larger package. Optimal performance is obtained with this chosen bus width if the size of the frequently used register-to-register operations becomes one word. The choice of ALU and internal register widths is a tradeoff between speed of the most frequent operations and the chip area needed to implement a wider ALU or data path inside the CPU.

None of these implementation decisions should limit the architecture. Instructions are from one to five words long, and data types and addresses are not limited to 16 bits. For example, 32-bit words are one of the main data types of the machines, and addresses occupy two words. The address mechanism illustrates the strong distinction between an architecture and its implementation. The architectural address representation uses a 32-bit word of which 6 bits are reserved and 1 is a short format long format descriptor. Thus, the Z8000 architecture provides up to 31-bit addresses, but only 23 are currently implemented and 23 pins of the current package are allocated to addresses.

MMU tradeoffs. The MMU and its relation to the Z8000 CPU illustrate tradeoffs that a microprocessor architect and designer team must make to ensure component manufacturability.

To achieve the goals of good architectural compatibility for high-end systems, it was necessary to include the protection and relocation mechanisms described above. But if all desired features were implemented as a one-chip CPU/MMU combination, it would have been too large and, therefore, uneconomical. And if a reduced set of features were implemented, it would have been architecturally too primitive. Thus, the choice was made to maintain all features and use two chips. This new organization has several significant advantages, such as a capability for multiple MMUs, and allows the access of a DMA device to the MMU.

Given the choice of an external MMU, the next set of decisions concerns package size and circuit speed. Having each relocated segment start on a word boundary would have required a 64-pin package and a very fast 24-bit adder (in fact, a 16-bit adder and 8 bits of carry propagation). In contrast, the decision to start segments on 256-byte boundaries allows the use of a 48-pin package, a fast 8-bit adder, and 8 bits of carry propagation. The latter solution is technically superior and places practically no restriction on the architecture. Segment granularity can be viewed as an implementation restriction and not as an architectural restriction.

Making the 8 low-order bits of the offset go directly to memory also significantly reduces memory access time. Since dynamic memories use these bits first, most of the MMU relocation time is hidden during a

normal memory access. The availability of segment numbers earlier than the associated offset bits reinforces this advantage and allows the MMU to result in essentially no memory access speed reduction. Each MMU entry also requires 8 bits less for base and segment size value. This is important; it is desirable to pack as many entries as possible per MMU. With 64 entries a 2K-bit memory is needed, which is technologically difficult in view of the amount of logic surrounding this memory and the complexity of its organization.

The fact that an MMU is only connected to the upper byte of the data bus requires the use of special I/O instructions for its loading and obliges us to replace the possible use of an automatic demand loading of entries by explicit instruction loading. To compensate for the time penalty associated with the loading of potentially unused entries, multiple MMUs are used. They not only allow the implementation of 128 entries, but pairs of MMUs can be automatically enabled by the system and normal mode pins effecting a full environment switch at electronic speed.

We feel this example illustrates one important design approach: to compromise as little as possible on advanced architectural features but to accept compromises which result in implementation ease in order to achieve economical components.

Conclusion

The architectural sophistication of the new 16-bit microprocessors is rapidly approaching the level of the minicomputer and large computer. Problems such as component families, large address spaces, bit standards, I/O structures, software investments, and architectural compatibility are being directly addressed. Some of the solutions to these problems are known, and therefore the transition from 8-bit microprocessors was relatively easy. But the challenges ahead—networks, distributed processing, new applications—are much harder. The impact of microprocessors is already enormous, but we feel they will achieve the often-predicted computer revolution only after these new problems are solved. ■

Acknowledgements

The Z8000 family would not exist without the very talented and dedicated designers who contributed to and implemented the ideas described in this paper: Takatoshi Shima for the Z8000, Hiroshi Yonezawa for the MMU, and Ross Freeman for the peripheral devices. Judy Estrin made invaluable contributions to the architecture of the Z8000 and Z8. Many discussions with Charlie Bass, Leonard Shustek, and Forest Baskett have greatly influenced the Z8000. Leonard's instruction set measurements were especially valuable. Dennis Allison, Steve Meyer, Bruce Hunt, and many others must be thanked for their comments on early drafts of this paper.

References

1. B. L. Peuto and L. J. Shustek, "Current Issues in the Architecture of Microprocessors," *Computer*, Vol. 10, No. 2, Feb. 1977, pp. 20-25.
2. *Zilog, Z8000 Technical Manual*, Zilog, Inc., 1979.
3. *Zilog, MMU Technical Manual*, Zilog, Inc., 1979.
4. *Zilog, Z-Bus Specification*, Zilog, Inc., 1979.
5. A. Lunde, "Empirical Evaluation of Some Features of Instruction Set Processor Architectures," *CACM*, Vol. 20, No. 3, Mar. 1977, pp. 143-152.
6. L. J. Shustek, *Analysis and Performance of Computer Instruction Sets*, PhD Dissertation, Dept. of Computer Science, Stanford University, Stanford, Calif., Jan. 1978.
7. B. L. Peuto and L. J. Shustek, "An Instruction Set Timing Model of CPU Performance," *Proc. Fourth Annual Symposium on Computer Architecture*, Mar. 23-25, 1977, pp. 165-178.
8. C. Bass, "PLZ: A Family of System Programming Languages for Microprocessors," *Computer*, Vol. 11, No. 3, Mar. 1978, pp. 34-39.
9. A. S. Tannenbaum, "Implications of Structured Programming for Machine Architecture," *CACM*, Vol. 21, No. 3, Mar. 1978, pp. 237-246.
10. N. G. Alexander and D. B. Worlman, "Static and Dynamic Characteristics of XPL Programs," *Computer*, Vol. 8, No. 11, Nov. 1975, pp. 41-45.

Bernard L. Peuto is one of the guest editors for this special section; his biography appears with the introduction on p. 9.

**LA VEZZI
MOLDED
SPROCKETS**

**A PRECISE WAY TO DRIVE
CHARTS ECONOMICALLY**

Drives perforated materials with unvarying accuracy. Maintains chart integrity. 10, 12 and 24-tooth thermo-plastic sprockets are formed to exacting specifications. 1/4", 1/10" and 5mm pitch. Immediate delivery.

Our catalog tells all.

LaVeZZi machine works, Inc.

600 N. Leich Ave. • Elmhurst, Ill. 60126 • (312) 834-6980



A system designer and teacher, who has made liberal use of microcomputers in his own work and whose students have designed 8048 processors, reviews the capabilities and limitations of the MCS-48 family of microcomputers.

The Intel MCS-48 family of single-chip microcomputers contains at least nine different microcomputer chips having a common instruction set but different amounts of on-chip read-only memory, read/write memory, and input/output (see Table 1). Ac-

Table 1.
MCS-48 microcomputers.

PART #	PACKAGE SIZE (pins)	ON-CHIP PROGRAM MEMORY (bytes)	ON-CHIP DATA MEMORY (bytes)	I/O (lines)
8048	40	1K ROM*	64**	27
8748	40	1K EPROM*	64**	27
8035	40	none*	64**	27
8049	40	2K ROM*	128**	27
8039	40	none*	128**	27
8021	28	1K ROM	64	21
8022	40	2K ROM	64	23 plus 2 8-bit A/D conv.
8041	40	1K ROM	64	18 plus master sys. ctrl.
8741	40	1K EPROM	64	18 plus master sys. ctrl.

* Expandable to 4K with external chips.

** Plus 256 bytes or more of external data memory with external chips.

Table 2.
MCS-48 expander chips.

PART #	PACKAGE SIZE (pins)	ON-CHIP PROGRAM MEMORY (bytes)	ON-CHIP DATA MEMORY (bytes)	I/O (lines)
8355	40	2K ROM	none	16
8755	40	2K EPROM	none	16
8155/56	40	none	256	22 plus bus/counter
8243	74	none	none	16

According to Intel, the MCS-48 family was designed primarily at the "4-bit market"—users of Intel's 4040 and other low-cost microcontrollers. Recent entries into the family (the 8021, 8022, 8021, and 8741) are increasingly specialized for low-cost microcontroller applications. The MCS-48 family has done this market very well.

The MCS-48 family was also aimed at a second market—applications that require an expandable, single-chip, general-purpose microcomputer. As shown in Table 2, several expansion chips are available to provide an MCS-48 computer with up to 4K bytes of program ROM, 256 or more bytes of external RAM, and as many I/O bits as a designer would ever need. In addition, the external I/O bus of the MCS-48 family allows easy interfacing of standard 8080-compatible peripheral chips. Nevertheless, the architecture of the MCS-48 family makes it difficult to use in many general-purpose applications, where a more capable 8-bit architecture is required.

Basic architecture

Figure 1 shows the basic structure of a microcomputer chip (Table 1) and the options available for each of the microcomputers in the MCS-48 family that had been announced by Intel in 1978 (the first members of the family were announced in late 1976—the 8018 with 1K bytes of on-chip ROM and 64 bytes of RAM, 16 master sys. ctrl. and 27 I/O lines). A detailed description of the internal architecture is found in the user's manual published by Intel.¹

The MCS-48 is a single accumulator architecture. Program memory and data memory are logically and physically separated (thus, the MCS-48 is not a Harvard

known machine!). The maximum program address space (including external ROM) supported by the architecture is 4K bytes. There are a maximum of 1024 bytes of on-chip (internal) data memory, of which 256 bytes are implemented in the current family leader, the 6019. In addition to internal data memory, the MCS-48 directly supports 256 bytes of external data memory.

Most MCS-48 family members have 27 I/O pins, arranged in three 9-bit ports, two test inputs, and an interrupt pin. Additional pins are provided for such functions as power-on reset, single stepping, and memory and I/O expansion strobes. One 8-bit port and a part of a second are used to form a multiplexed address and data bus for I/O and memory expansion.

The MCS-48 has a single-level interrupt system (only one interrupt in service at a time) and accepts interrupts from two sources—its internal timer/counter and an external interrupt input pin. Interrupt calls and returns automatically push and pop the program counter and certain internal status flags onto a stack in the internal data memory.

Program store and program control

The MCS-48 architecture supports a maximum of 4K bytes of program store, configured as shown in Figure 2. However, a close look at program-store organization shows that the MCS-48 was originally designed as a 2K-byte machine, with the second 2K byte capability added as a clumsy afterthought. This creates two problems with the addressing mechanism.

First, the program counter is really only 11 bits and thus addresses instructions only within a 2K-byte block of program store. Jump and subroutine call instructions likewise specify an 11-bit address. The problem, then, is how to provide a 12-bit address bit.

The solution is as follows. Provide an internal flag, MB, that can be set and cleared by two instructions (SET MB and CLR MB, respectively). Whenever a jump or subroutine call is executed, take the 11 low-order bits from the instruction, and load the high-order bit from MB. On subroutine calls and returns, push and pop the entire 12-bit address.

There are some problems with this solution. First, a sequence of jumps and calls in a 4K system will not always know where we came from, and the programmer can't track the current value of MB. So the programmer's set and clear instructions must precede every jump or call. Naturally the programmer can come up with a solution to this instruction on a case-by-case basis, but this is another thing to worry about.

If we solve the first problem, we think we understand the addressing mechanism until we write our first interrupt routine. Then we wake up in the middle of the night thinking, "We forgot MB can't be read as part of the processor state PSW. But MB must be set to a new value in order to do jumps within interrupt routine. How can the old value be restored on return?" We lie awake a few hours dreaming up possible solutions—don't use calls or jumps in in-

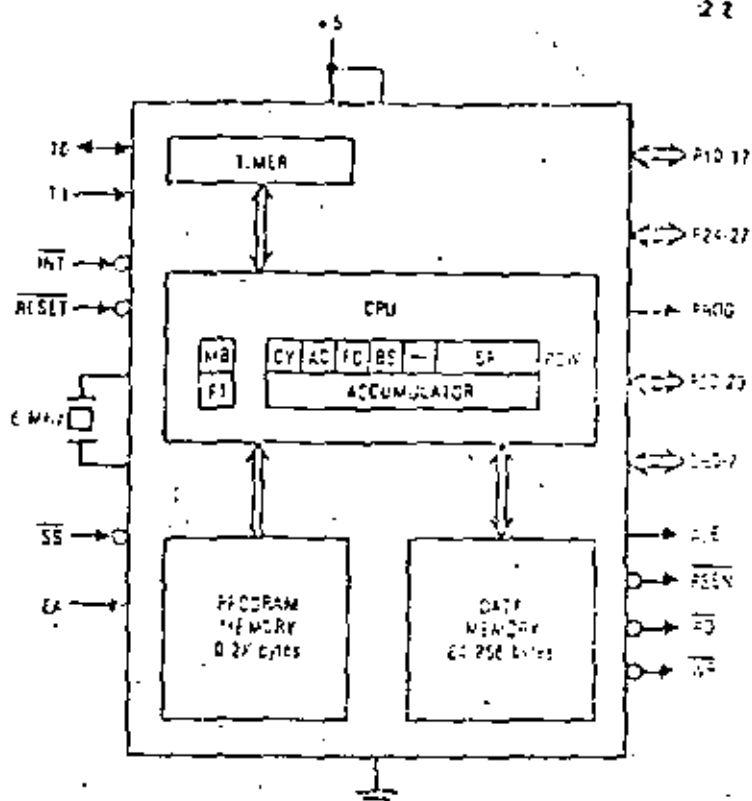

Figure 1. Basic structure of a typical member of Intel's MCS-48 family of microcomputers.

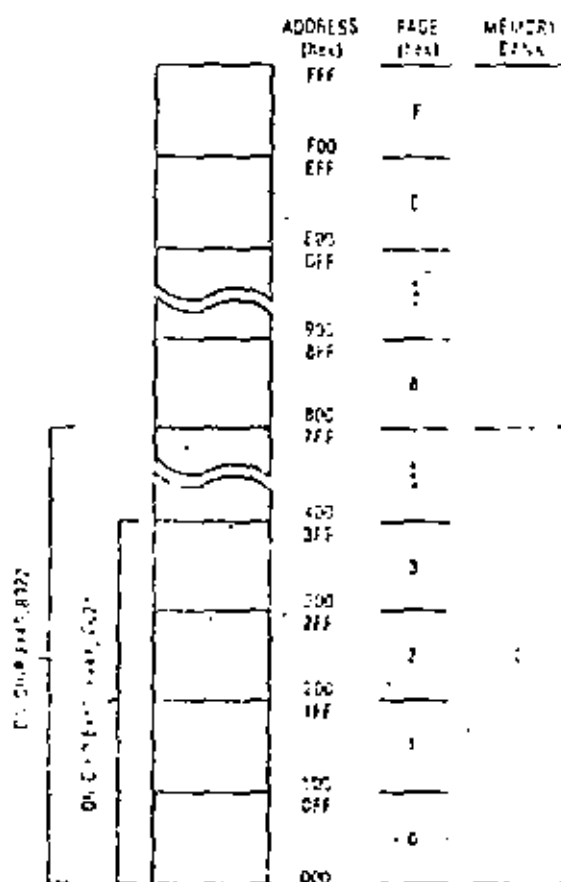

Figure 2. MCS-48 program memory.

How to choose a microcomputer

There are at least six factors to consider in choosing a microcomputer (or microcomputer family) for a product application.

Capability. The μ C must have enough ROM, RWM, I/O capability, and speed to satisfy the requirements of the application, plus a design margin. ROM, RWM, and I/O capability can be determined from the manufacturer's literature, while speed is best determined from benchmark programs tailored for the given application.

With some μ Cs, the amount of ROM, RWM, and I/O can be increased by using extra chips. This expandability helps if the job is initially underestimated or if the marketing department changes the requirements. If the application pushes the absolute memory limits of the μ C, it becomes more difficult (and expensive) to develop the programs.

Extensibility. The designer must consider whether improved versions of the μ C will be offered. A μ C-based product designed in 1979, for example, might be redesigned in 1981 to reduce cost or to add features. It would then be desirable to eliminate extra ROM, RWM, and I/O chips (or avoid having to add them or pick a different μ C) by using a new version of the original μ C with the extra capability built in. Of course, many products do not undergo this evolution; but if product evolution is expected, the architectural limits of the selected μ C should be examined in light of potential application requirements. One can expect lower hardware and software development costs and, probably, lower manufacturing costs if the enhanced product uses an upgraded version of the original μ C rather than a completely new one.

Cost. In most areas of the private sector, minimizing cost is a goal, and minimizing μ C cost usually means minimizing the number of IC packages. Cost is what prevents the designer from picking a Cray-1 in response to the first factor above, or an IBM 370 in response to the second factor.

If the job is well defined and no product enhancement is anticipated, it is relatively easy to find a minimum-cost μ C that will do the job. Otherwise, there are many more tradeoffs to be considered. A simpler μ C architecture usually implies a smaller IC die and lower chip cost, but it may also require more chips to support it later. (For example, a μ C without a WAIT/READY line may be more difficult to interface to some types of peripherals or memory.) An expandable μ C will facilitate later product evolution (if the product is successful), but may increase initial product cost because of instruction efficiency, memory size, I/O pins, or speed sacrificed by the chip designers to make expansion or enhancement possible.

Availability. Many manufacturing organizations require a second source for all components, both to ensure that parts will be available, even if some disaster befalls one source, and to enjoy the normal benefits of competition in a free market.

The designer of a new product is often tempted to select between a μ C with one or two sources and one with no sources (yet—"We'll have samples in three months"). It is risky to commit to any part unless your

purchasing department can order (and receive) 100 pieces from a distributor's shelf. Manufacturers have been known to slip schedules and even cancel parts.

On the other hand, marketing and cost factors can motivate the selection of a not-yet-available or very new μ C. The new μ C can give the product a competitive edge in features or performance. Although the new μ C may be in short supply and costly initially, it may be cheaper in the long run because it allows a more efficient design with fewer IC packages.

Expected product lifetime should also be compared with the expected lifetime of the μ C. Even if it is inexpensive currently, a μ C that has been around for a few years may be a bad choice. Production quantities may fall and prices rise in a few more years as newer chips are phased into new designs. Of course, this doesn't apply if your company alone is ordering 100,000 pieces per year.

Support tools. Hardware and software support tools are essential for timely development of a μ C-based product. The support tools of a newly introduced μ C cannot be expected to be as extensive or reliable as those of an established μ C family. This encourages the use of an established μ C if quick development is needed, or an extensible μ C family with reusable tools if product evolution is expected.

Most single-chip μ Cs are programmed in assembly language, and a good macroassembler is a must. Most manufacturers supply software tools that run on their own development systems. However, if there are more than one or two programmers on the project, the need for good text editors, simulators, and documentation facilities makes it desirable to run all software support tools on a large central computing facility. The appropriate "cross assemblers" and simulators may or may not be offered by the chip manufacturer.

During product development it is obviously necessary to test and change programs running on the product hardware. Since most single-chip μ Cs ultimately use mask-programmable ROM to store their programs, another means is needed to store and change programs during development without making new masks. Some μ Cs have pin-compatible versions with on-chip EPROM instead of ROM that allows reuse of the μ C chip with different programs. Many have provisions for using external EPROM chips instead of the on-chip ROM. If production quantities are low, or if software changes are expected after product introduction, EPROM versions may be essential.

Besides EPROM facilities, the main support tool provided by the chip manufacturer is the in-circuit emulator, which stores the software program in the PROM of a development system and emulates the μ C through a cable and plug inserted in place of the μ C in the product. An emulator is a useful tool for debugging both hardware and software. However, with new μ Cs, it may not be available as soon as the μ C chips are, and even if it is, it may still have bugs.

Specific technical factors. Many specific technical factors can be examined in determining whether a μ C will do the job at hand—power consumption, speed, TTL compatibility, package size, instruction set. However, once it is determined that the μ C can do the job, the other factors above tend to equal or outweigh the technical "niceness" of the μ C chip architecture.

interrupt routines, determine the value of MB experimentally by doing a jump to a fixed location and seeing whether it winds up in MB0 or MB1; keep a software copy of MB, updating it (with interrupts disabled, of course) every time we do a SELMB; make all the code fit in 2K, as we expected to do at the start of the project; and so on. The next morning we read the fine print to discover that the MCS-48 forces the most significant bit of the program counter to 0 during all interrupt routines. We should put all of our interrupt code in the bottom 2K of memory and not touch MB; in fact, we should forget that MB exists!

The requirement to put interrupt code in the bottom 2K makes the MCS-48 very difficult to use as a 4K machine in a real-time application. Not only must the basic interrupt service routine be in the bottom 2K but also any utility routine that might be called by it—that is, any code executed before an interrupt return instruction is executed. This could be well over half the code in an interrupt-driven environment.

But the main problem we find with MCS-48 program store, after writing half of our applications programs, is that the address space is just too small. With only two chips (and soon with just one, I'm sure) we can fill the entire 4K-byte address space of the MCS-48 with code for our original application, new features, diagnostics, and—of course—patches.

Conditional jumps specify an 8-bit target address in the current page; it would be far more useful to have a signed offset from the current address.

The annual halving of the cost of IC memory implies that every year we will need another address bit for the maximum-size application program (since most evolving products tend to use the decreased memory cost to increase features, not to reduce product cost). Clearly, then, a 4K limit is too low for any new architecture, even a single-chip microcomputer.

Besides the 2K memory banks, program store is also divided into 256-byte pages. Conditional jumps specify an 8-bit target address in the current page. It would be far more useful to have a signed offset from the current address; this would increase the likelihood of being able to use the short jump address, since most branch targets are within 128 bytes of the branch instruction.² More importantly, it would eliminate the partitioning problem created when many procedures must be packed into the memory space and split across page boundaries.

The only indirect jump instruction also uses an 8-bit target address in the current page. Very strangely, this instruction uses an 8-bit value in the accumulator not as the target address, but as a pointer to a program-store byte in the current page that contains the target address. So the page containing the indirect jump instruction must also contain all of the routines to be jumped to, as well as a silly little table that contains their starting addresses in the page. This not only wastes space and time, but,

worse, makes it impossible to dynamically compute a target address after assembly time, since the jump table is in ROM. In my recent experience, three experienced programmers have coded MCS-48 indirect jumps improperly, believing "The manual must have a typo—the contents of the accumulator must be the target address itself." In any case, instructions supporting indirect jumps and calls anywhere in the program store (12-bit address) would be far more useful!

Arithmetic and logical operations

The MCS-48 contains a single accumulator in which arithmetic and logical operations take place. Unary operations on the accumulator are as follows:

- increment,
- decrement,
- clear,
- one's complement,
- decimal adjust,
- swap nibbles,
- rotate left,
- rotate left with carry,
- rotate right, and
- rotate right with carry.

Binary operations combine the accumulator and a 16-bit operand specified by one of the addressing modes described in the next section. The binary operations are:

- add,
- add with carry,
- AND,
- OR, and
- exclusive OR.

There are also "data-move" operations that load or store the accumulator.

The main difficulty with MCS-48 operations (is not the operations themselves) but the lack of condition codes for testing their results. Only the accumulator can be tested for zero or negative, and an overflow bit is not provided, making comparisons of signed two's complement numbers very frustrating.

Operands

Most data moves and binary operations use an on-chip read/write internal data memory (see Figure 2) accessible by two addressing modes: REGISTER and INTERNAL REGISTER INDIRECT. The three other addressing modes are EXTERNAL REGISTER INDIRECT, IMMEDIATE, and ACCUMULATOR INDIRECT.

In REGISTER mode an operand is contained in a register specified by a 3-bit field in the instruction. A flag bit BS, set by a SELRB instruction, specifies one of two 8-byte register banks, corresponding to internal data memory locations 0-7 if BS is 0 and 24-31 if BS is 1. The specified register may be loaded with an immediate value, moved to or from the accumulator, combined with the accumulator by arithmetic or logical operations, incremented, decremented, or used as a loop counter.

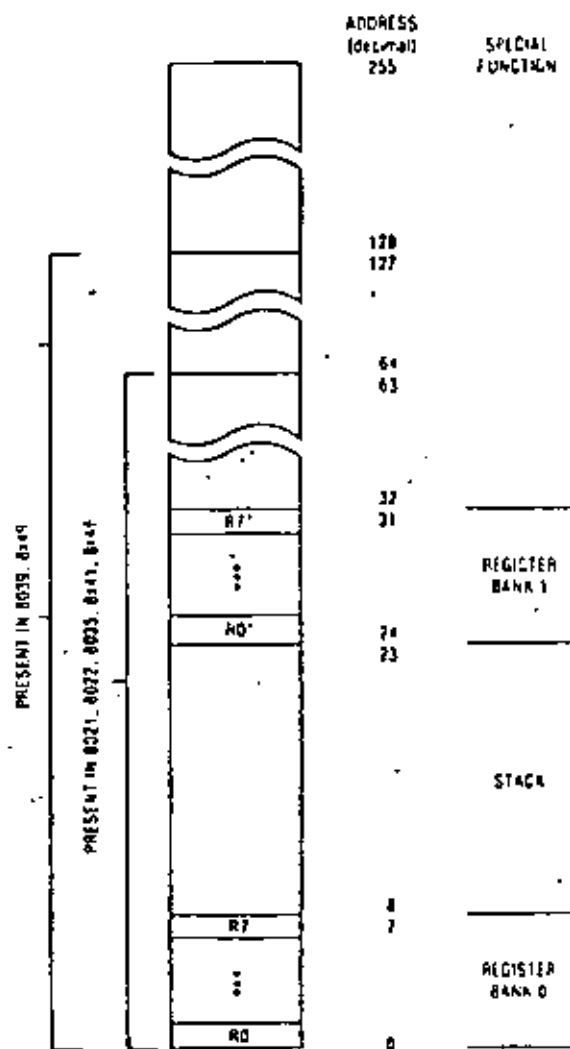

Figure 3. MCS-48 internal data memory.

INTERNAL REGISTER INDIRECT allows either R0 or R1 in the current register bank to be used as an 8-bit pointer to internal data memory. The addressed byte may be loaded with an immediate value, moved to or from the accumulator, combined with the accumulator, or incremented (but for some obscure reason not decremented, even though the necessary "hole" exists in the instruction set).

Locations 8-23 of the internal data memory are reserved for a return address stack (8 entries, 2 bytes per entry). These locations are written by interrupts and subroutine calls and read by interrupt and subroutine return instructions. The stack is too small, making it hard to write procedural code, which is important in larger programs (2K-4K bytes). The programmer must constantly worry about calling sequences and generally enable interrupts only at the top level of the program to avoid overflowing the stack.

There are no instructions to directly push or pop a byte. However, the stack can be rather inconveniently written or read by extracting the stack-pointer field from the PSW, building the appropriate address, and using **INTERNAL REGISTER INDIRECT** mode.

The architecture also supports up to 256 bytes of external data memory (which resides on a separate chip), accessed by **EXTERNAL REGISTER INDIRECT** mode. Either R0 or R1 in the current register bank may be used as an 8-bit pointer to external data memory; the addressed byte may be copied into the accumulator or written from the accumulator.

Since pointers are contained in 8-bit registers, the maximum amount of directly accessible data memory supported by the MCS-48 architecture is 256 bytes internal plus 256 bytes external. However, bank switching via I/O bits can be used to address any desired amount of additional external data memory.

The modes for reading operands from program store are rather limited. In **IMMEDIATE** mode an operand is contained in the byte following the instruction; immediate operands can either be loaded into or combined with the accumulator or be loaded into internal data memory with **REGISTER** or **EXTERNAL REGISTER INDIRECT** modes.

In **ACCUMULATOR INDIRECT** mode the accumulator is used as an 8-bit pointer to an operand in either the current page or page 3 of program store; only one type of operation uses this mode, and it loads the accumulator with the specified operand.

A number of instructions specify some "special" operands implicitly, such as the program status word, I/O ports, timer/counter, carry bit, and two 1-bit flags, F0 and F1.

The MCS-48 addressing modes are simple, but they provide most of the facilities a program needs. Still, there are some deficiencies. The most serious problem is the way in which operands in program store are addressed. Since program store only in the current page and in page 3 can be read through a pointer, either look-up tables must all be located in page 3 or the code that reads each table must be in the same page as the table. This is inconvenient if more than one 256-byte translation table is needed. It also makes it difficult to do a ROM checksum self-test routine—a checksum subroutine would have to be placed in every page of program store, and since there is no indirect addressing, all the main checksum program would have to contain a separate call instruction to each page's checksum routine.

For most programs, the method of indirectly addressing data memory through R0 and R1 is acceptable, but, for some data structure manipulations, one wishes for one or two more registers that could be used as pointers.

The 256-byte limit on directly addressable internal data memory is too low. The 2048 already contained 128 bytes of RWM, and Intel should soon be able to provide the full 256 bytes of RWM on the chip. The architecture cannot make straightforward use of technology improvements for more RWM once this limit is reached.

Input/output and interrupts

Most MCS-48 microcomputers have three 8-bit I/O ports, as shown in Figure 4. Two of the ports (I and O)

are "quasi bidirectional," an interfacing arrangement shown in Figure 4. This type of I/O port was first introduced in the Fairchild F8.⁹ In this arrangement, each I/O pin is both an open-drain output and an input pin with a high impedance pullup to the logic 1 level. When a pin is used for output, the corresponding input buffer is unused except, possibly, for checking the output value. When a pin is used for input, the corresponding output bit must be set to logic 1 so that the I/O device drives only the high-impedance pullup. This can be contrasted with a tristate I/O port, which provides both active pullup and active pulldown in output mode and high impedance in input mode. Electrically, tristate I/O is more desirable, but it requires extra control bits to set the I/O direction for each port or bit. Intel has improved the quasi-bidirectional design by briefly providing active rather than passive pullup whenever a 1 is written to the port, which speeds up 0 to 1 transitions.

What quasi-bidirectional I/O means to the programmer is that input data on the port is logically ANDed with the current output. Ports 1 and 2 are set to all 1's at system reset, and the programmer must leave bits intended for inputs set at output value 1 at all times. The third port (bus) has conventional tristate outputs and can be used for eight strobed inputs, for eight strobed outputs, or for adding external program or data memory.

Four operations on the ports are available:

- read input value into accumulator (IN),
- load output latch from accumulator (OUTL),
- logical AND output latch with immediate mask (ANL), and
- logical OR output latch with immediate mask (ORL).

The logical operations allow a program to set or clear any bit or group of bits in one instruction. However, since the mask is an immediate value in program store, the bits to be set or cleared must be known at assembly time. Otherwise, a copy of the output value must be kept in data memory, combined with the mask by logical operations on the accumulator, and loaded into the port. (In general, the quasi-bidirectional interface prevents simply reading the port to get the old value of the output latch.)

A novel "expander-port" arrangement allows four external 4-bit I/O ports to be added to an MCS-48 using a five-wire interface. Again, four operations on the ports are available:

- read input value into accumulator,
- load output latch from accumulator,
- logical AND output latch with accumulator, and
- logical OR output latch with accumulator.

Only the low-order four bits of the accumulator are used in these operations. For these ports, dynamic selection of mask bits is possible because the mask is in the accumulator. On the other hand, dynamic selection takes more overhead because the accumulator must be loaded with the mask (and then possibly restored to its old value).

Both the on-chip and expander I/O port instructions contain the port number as an immediate value

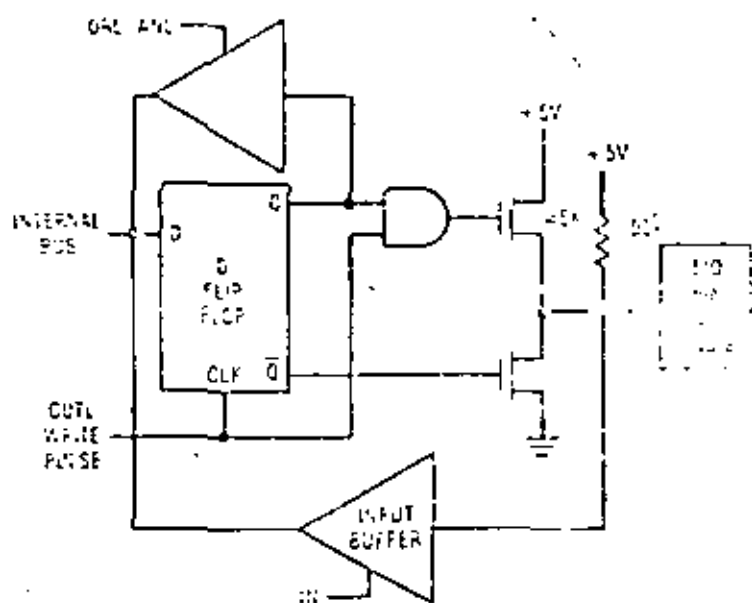

Figure 4. "Quasi bidirectional" I/O port.

in the instruction; it is not possible to specify the port number dynamically in a register. This makes it impossible to write reusable I/O handlers for identical devices on different ports of the MCS-48 or of the same expander chip. The same problem exists in the MCS-48's older brother, the 8050. However, it is less serious in the MCS-48 for two reasons. First, the MCS-48 is intended for smaller applications, less likely to employ many copies of the same I/O device. Second, the available I/O expansion modes do allow dynamic device selection when each device uses a separate I/O chip.

The processor architecture directly supports only 256 bytes of external data memory and four expandable 4-bit I/O ports. However, the amount of external data memory and I/O can be increased to any practical amount using on-chip I/O-port bits to implement program-controlled bank switching.

In addition to the I/O ports, an MCS-48 has three additional input pins that can be tested by conditional jump instructions. All are multipurpose pins—T0, which can be set up as a clock output under program control; T1, which can be used as the input to the on-chip timer/counter; and the external interrupt input.

The MCS-48 accepts interrupts from two sources—a level-sensitive input pin and an on-chip timer/counter. When an interrupt is serviced, the 19-bit PC and four status bits (carry, half carry, flag 0, register bank select) are pushed onto the internal stack. Depending on the source, a jump to either location 3 or location 7 is taken. The interrupt system is single-level; interrupt service routines cannot be interrupted. An interrupt return instruction restores the PC and status bits and allows further interrupts to be serviced.

At the time of this writing, the T1 interrupting pin is generally useless for counting or timing asynchronous (usually external) events, because the current chip

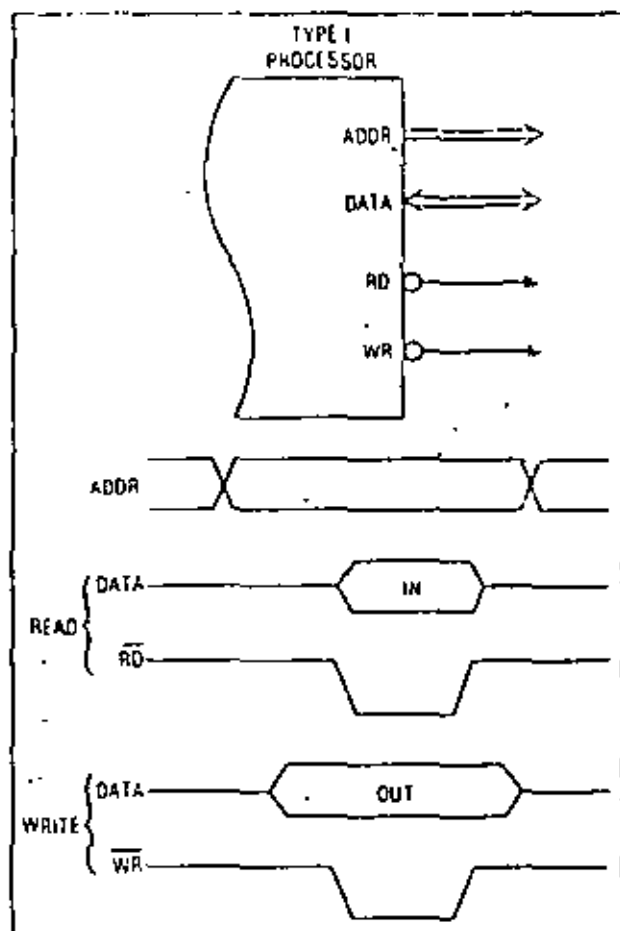

Figure 5. Type I bus control signals.

A tale of two buses (or, different strobes for different 'phobes)

A microprocessor memory and I/O bus has many identifying characteristics—data and address word length, multiplexed or nonmultiplexed address and status, separate or memory-mapped I/O, and others.² It is interesting to look at two popular read/write clocking arrangements.

Let us call the first technique a Type I (or 1) interface, used by the Intel 8085, 8086, and MCS-48 families. As shown in Figure 5, there are two mutually exclusive control pulses, \overline{RD} and \overline{WR} , that indicate a read or write operation.

We'll call the second technique Type Z (or 2), used by the Zilog Z8, Z80, Z8000, and also by the Motorola 6800 family. (Perhaps it should be Type M because the M6800 came first, but Z looks more like 2.) It is also used in principle by MCS-48 expander ports. As shown in Figure 6, there is a single control pulse, \overline{RD} , and a level signal \overline{RW} that indicates which type of operation is to take place. The timing of \overline{RW} is similar to that of an address signal.

Figure 7 shows how to use a Type Z processor with a Type I peripheral chip. The decoding shown in the figure can be easily implemented with one-half of a TTL 74LS139 dual 2 to 4 decoder (this even leaves an extra control input for distinguishing between memory and

I/O if desired). Assuming that processor and peripheral speeds are comparable, there should be no problem in satisfying the timing requirement of either the processor or the peripheral chip.

Ease of programming

Compared to some of the older 4-bit and 8-bit microprocessors, the MCS-48 is a nice machine to program, but it leaves much to be desired compared with an M6801, a Z8, or even an 8086. The single accumulator architecture, the lack of index registers, and the absence of even a direct data memory addressing mode means that the programmer must constantly be moving things back and forth between the accumulator, the two "pointer" registers $R0$ and $R1$, and the rest of the data memory (and keeping track of them!). One may write macros to ease the burden somewhat, at the expense of more inefficient code in the cramped address space. For example, you can write a macro to simulate a direct data memory addressing mode:

```
LDA  MACRO MEM, ADDR
MOV  R0, #MEM+128
MOV  A, R0
ENDM
```

Figure 8 shows an attempt to use a Type I processor with a Type Z peripheral chip. The logical \overline{RD} and \overline{WR} from the processor nicely produces \overline{RD} for the Type Z peripheral. \overline{RD} has the correct logic value to serve as \overline{RD} , but its timing is a problem. The Type Z peripheral expects \overline{RW} timing to be similar to character to an address signal, that is, it should be valid long before the \overline{RD} pulse appears. The only way we could ensure this would be to artificially delay \overline{RD} long enough for \overline{RD} to satisfy the setup time of \overline{RW} . Unfortunately, such a delay (unless highly asymmetric) would also delay the trailing edge of \overline{RD} until long after \overline{RW} (\overline{RD}) had gone away—upside down!

The cleanest way to use a Type I processor with a Type Z peripheral chip is to use an address line as \overline{RW} . For example, the least significant bit of the I/O port address could be reserved as \overline{RW} . Hardware decoding of actual port numbers would use the higher-order bits; then software would have to ensure that writes always used odd port addresses, and reads used even.

The conclusion is that it is simple to connect Type I peripherals to Type Z processors, but that the reverse can be difficult. Is this just the way it turned out or was there method to this madness?

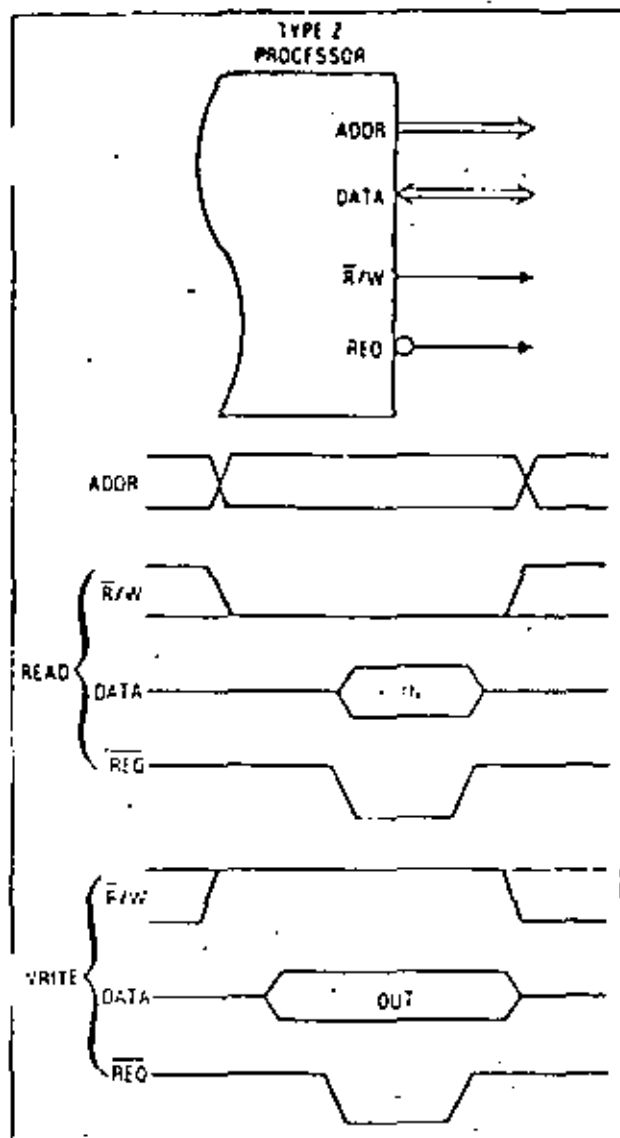

Figure 6. Type Z bus control signals.

To use such macros, however, the programmer must give up some registers for use by the macros. In the above example, macros would use R0, leaving only R1 available to the program as a pointer variable. (Buffer copying and other routines requiring two or more pointers get to be a problem.)

The lack of symmetry in the instruction set also creates programming headaches. For example, why are there INCR, INCR, and INCR instructions, but not DEC INC? Or, why can we conditionally jump on C, Z, T0, and T1 conditions true or false, but on F0, F1, TF, and accumulator bits only true? Except for accumulator bits false, the proper "holes" exist in the instruction set; in fact, it probably took more bytes to turn the instructions off than to let them work. I have been told that these "unimportant" instructions leave room for future enhancements, but any worthwhile architectural enhancements would require changes more sweeping than a few special purpose codes.

While nice programs can be written for the MCS 48, they take more effort than those written for

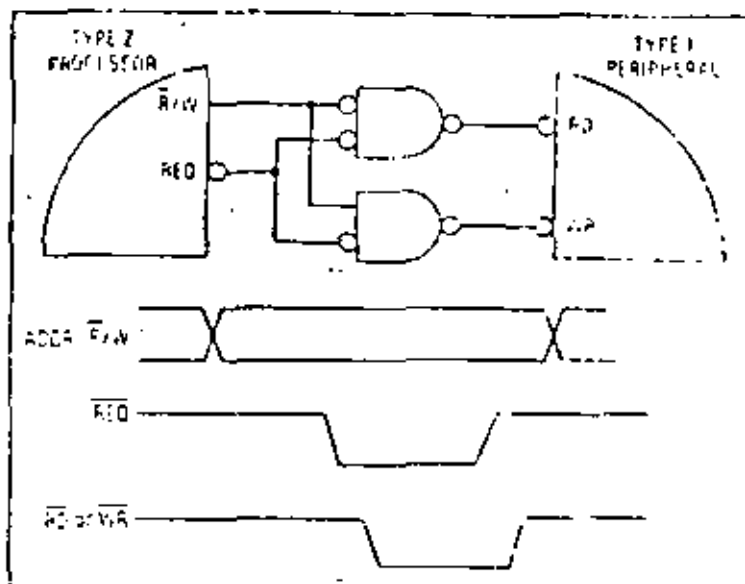

Figure 7. Acceptable Z to I interface.

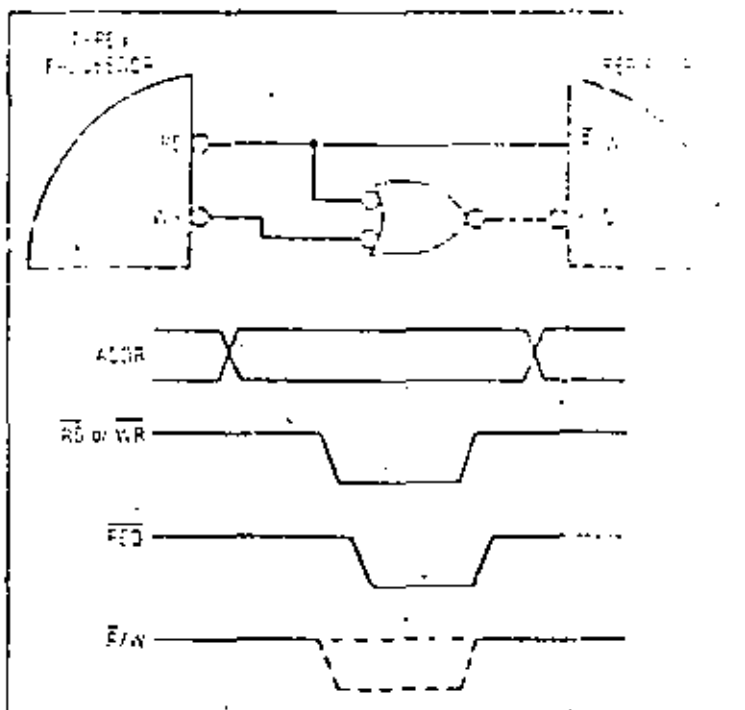

Figure 8. Unacceptable I to Z interface.

single purpose architecture. Programming will be slightly easier on a later processor as well as on the memory banks of the 64K 15V2. The 15V2 starts 100 bytes in program and stopping there, which the programmer expects. It's quite possible that if we are writing 10 different 256 to 256 bytes programs, the product will be shipped with 1000 bytes of memory buffers selected and more than 1000 on an expensive machine.

Some electrical characteristics

The MCS 48 uses Intel's relatively cheap 1.5 micron 1.5V CMOS process. Several second generation 1.5V

Acknowledgments

I appreciate the comments of my colleagues during the preparation of this article, especially those from Prem Jain, Paul Franz, Ed Yorwood, and Dave Stearns. The comments of the reviewers were also very helpful. Thanks go to Martin Allison for suggesting this article over a year ago, and to Bernard Peuto and Jan Shustek for making me finish it. Of course, special thanks go to Intel for bringing us the MCS-48.

Some of this material was prepared while I was a lecturer at the Digital Systems Laboratory at Stanford University. Other material is adapted from my textbooks, *Microcomputers, Vol. 1: Architecture and Programming and Microcomputers, Vol. 2: System Hardware Design*, to be published by John Wiley & Sons in late 1978. All opinions expressed in this article are my own.

References

1. Intel Corporation, *MCS-48 Family of Single-Chip Microcomputers User's Manual*, Santa Clara, Calif., July 1978.
2. L. J. Shustek, "Analysis and Performance of Computer Instruction Sets," Ph.D. dissertation, Stanford University, June 1975, available from University Microfilms, Ann Arbor, Mich.
3. J. F. Wakerly, "Microcomputer Input/Output Architecture," *Computer*, Vol. 11, No. 2, Feb. 1977, pp. 20-23.
4. T. J. Chaney, S. M. Ornstein, and W. M. J. van der Polder, "They were the Synchronizers," presented at COMPCON-72, IEEE Comput. Soc. Conf., San Francisco, Calif., Sept. 12-14, 1972.
5. T. J. Chaney and C. E. Melnar, "Anomalous Behavior of Synchronizer and Arbitr. Circuits," *IEEE TC (Corresp.)*, Vol. C-62, No. 4, Apr. 1973, pp. 401-402.
6. M. Pechourek, "Anomalous Response Times of Input Synchronizers," *IEEE TC*, Vol. C-65, No. 2, Feb. 1976, pp. 133-139.

MICROSYSTEMS

The first implementation of a new microprocessor architecture promises to narrow the gap between the power of very small and very large computers.

A Microprocessor Architecture for a Changing World: The Motorola 68000

Edward Stritter
Tom Gunter

Motorola Semiconductor

Microprocessor technology is entering a new and especially challenging era. While technology constraints have not completely disappeared, we are nearly to the point where the limiting factor in microprocessor design is not how much function can be included, but how imaginative and creative the designer can be.¹ As a result, several companies have introduced new-generation microprocessors. We describe how one of them, the Motorola 6800, responds to these unique conditions.

Motivations for a new microprocessor architecture

Previous generations of microprocessors were limited by the available technology. Brooks, in an overview article,² discusses how the technology constraints and the perceived microprocessor market motivated early microprocessor architecture. Microprocessors were limited in number of registers, data-path width, and instruction-set power primarily because technology could not support more features on a single chip. Other limitations of microprocessors, such as having too small an address space³ and awkwardness of address computation,⁴ may be attributed as much to prevailing perceptions of the potential market as to technology constraints.⁵ Whatever the former sources of restraint, however, we are now in a period of technical innovation and spirited competition.

Technological advances. The basic microprocessor technology, MOS, has been steadily advanced in the last few years. The most noticeable improvement has been circuit density (Figure 1), which translates

directly into the amount of capability that can be put on a single-chip microprocessor. Whereas earlier microprocessors contained from 1,000 to 10,000 transistors per chip, current processors have from 10,000 to 70,000 transistors, which is less than an order of magnitude away from the number in many of the largest main computers. Circuit density is not the only technology advance that has been made, but corresponding improvements have been achieved in circuit speed and power dissipation.

Advances in technology have been more evolutionary than revolutionary. The major advance, increased circuit density, is the result of gradual improvements in processing techniques that permit smaller circuit dimensions. Density improvements are expected to continue, since they depend not on overcoming fundamental limitations but only on further evolutionary improvement of existing processes. New microprocessor architectures must be devised to take advantage of this future advancement.

Market demands. The demand for microprocessors in applications has increased just as fast as the technology, providing new opportunities for microprocessor manufacturers. Just as the original microprocessor designers could not predict the many uses that would be found for their devices, today's designers cannot hope to envision more than a few of the exciting applications of new microprocessors. The implication for the designer is that new designs must be broad and general if they are to be useful in a large number of potential applications.

High software costs. The problem of software cost is even more acute in microprocessor applications than in other computer systems generally. Developing a program costs

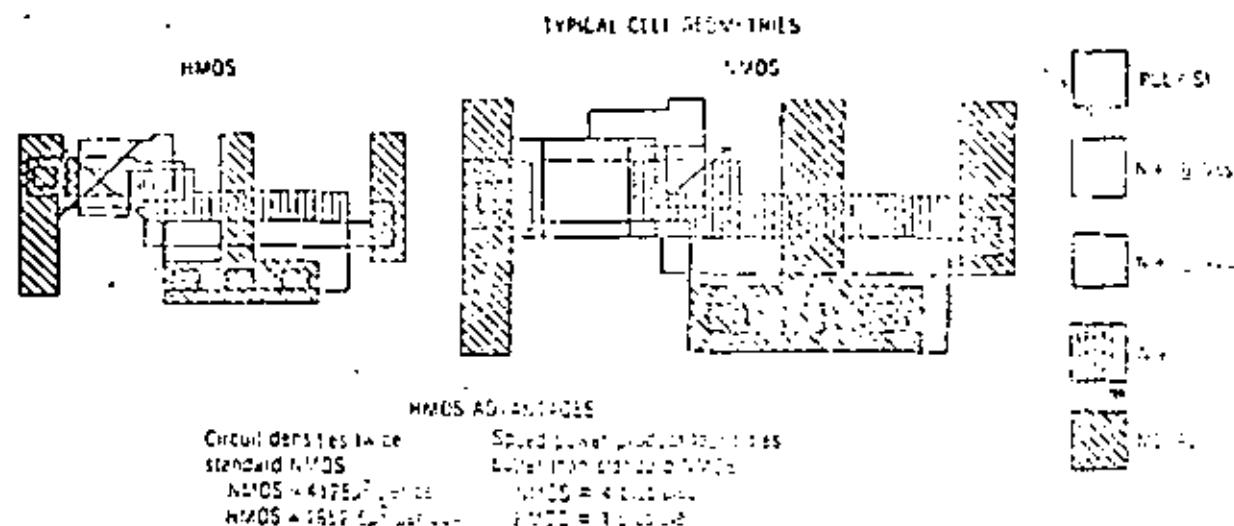

Figure 1. Comparisons of HMOS and NMOS technologies. The HMOS technology used for the MC6800 results in significant improvements to circuit densities and speed-power products.

increasing processor functionality, and more complex applications are combining to increase the size and complexity of microprocessors in programs. Software costs of \$100,000 or more are clearly incompatible with hardware costs of hundreds of dollars. This cost disparity may be unimportant in large volume applications, where software costs can be amortized over thousands of hardware units, but it often precludes the use of microprocessors in applications characterized by complex programs but low volume. To help reduce the high cost of software, microprocessor designers must make a strong commitment to supporting high-level languages and disciplined programming practices.

High design costs. The cost of designing and implementing a new device with tens of thousands of transistors is high. Computer design aids are indispensable, but they are also expensive. Designers must attack this design cost problem in several ways. First, straightforward designs, using regular structures, are easier to implement, test, and correct, and are therefore less expensive than exotic designs. Second, each new architecture must be planned to last for as long as possible and must be easy to expand in the future. Manufacturers can no longer afford to produce new architectures every few years. Experience with trying to extend and improve the original 8-bit microprocessor architectures demonstrates the need for planned expansion. Designers must be careful to include as few limitations to future expansion as possible. The most common mistake in the past has been limiting address size and not providing non-cooperation codes for future new instructions.

Design goals for the 6800. Motorola's 6800 microprocessor architecture has been designed to meet the requirements outlined above. (The MC6800's characteristics are summarized in Table 1.)

Architecture flexibility. The 6800 design goal was to produce a microprocessor that could be used in a wide variety of applications and environments. The first version of the 6800 is a general-purpose microprocessor that can be used in a wide variety of applications, from simple control systems to complex data processing systems.

Flexibility and expandability. The 6800 design goal was to produce a microprocessor that could be used in a wide variety of applications, from simple control systems to complex data processing systems. The 6800 is designed to be expandable in the future, to allow for special cases, or other developments in the architecture.

Marketability. The 6800 is a general-purpose architecture, reflecting the increasing market acceptance of general-purpose microprocessors in consumer applications.

Expandability. The 6800 design goal was to produce a microprocessor that could be used in a wide variety of applications, from simple control systems to complex data processing systems. The 6800 is designed to be expandable in the future, to allow for special cases, or other developments in the architecture.

Support of high-level languages. The 6800 design goal was to produce a microprocessor that could be used in a wide variety of applications, from simple control systems to complex data processing systems. The 6800 is designed to be expandable in the future, to allow for special cases, or other developments in the architecture.

Property	Value
Supply Voltage	5V
Operating Voltage	5V
Operating Current	10mA
Operating Power	50mW
Operating Temperature	0°C to 70°C
Storage Temperature	-55°C to 125°C
Package	8-pin DIP

Resources. The 68000 design provides an address space of 2^{24} bytes (limited to 2^{16} bytes in the initial implementation). Memory is byte addressable, with individual-bit addressing provided for bit manipulation instructions. Memory may be accessed in units of 1, 8, 16, or 32 bits. CPU resources include sixteen 32-bit registers, a 32-bit program counter (24 bits in the initial implementation), and a 16-bit status register.

The registers (Figure 2) are divided into two classes. The eight data registers are used primarily for data manipulation; they may be operand sources or destinations for all operations but are used in addressing only as index registers. The eight remaining (address) registers are used primarily for addressing. The stack pointer is one of the address registers. The program counter and status word are separate registers.

Addressing. Memory is logically addressed in 8-bit bytes, 16-bit words, or 32-bit long words. The current implementation requires that word and long-word

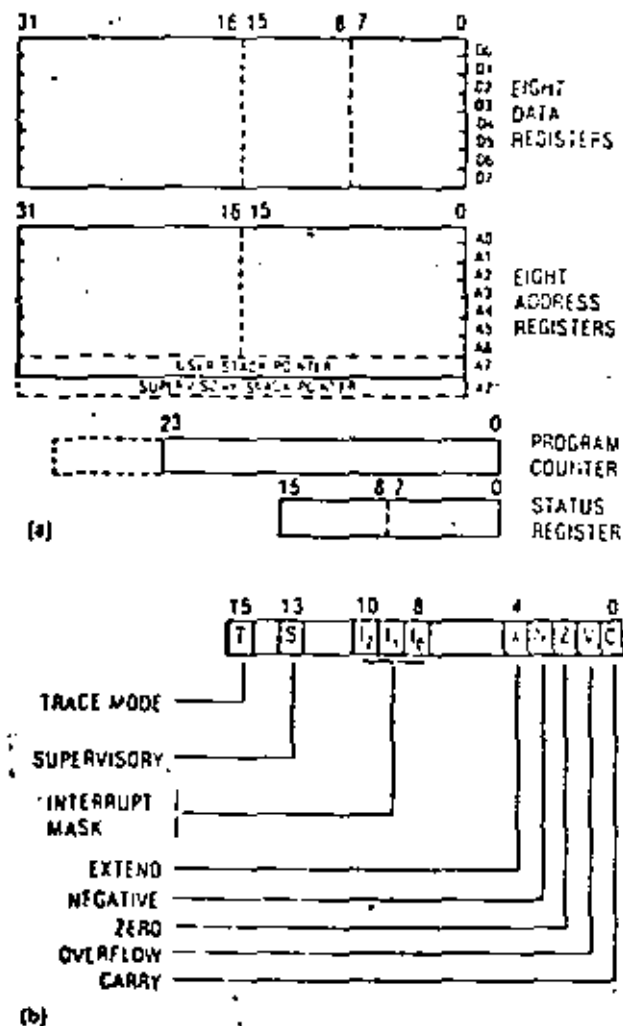

Figure 2. MC68000 programming model (a) and internal structure of status register (b).

Table 2.
MC68000 addressing modes.

REGISTER DIRECT ADDRESSING	
data register direct	EA = Dn
address register direct	EA = An
status register direct	EA = SR
REGISTER DEFERRED ADDRESSING	
register deferred	EA = (An)
register deferred post-increment	EA = (An), An ← An + 1
register deferred pre-decrement	An ← An - N, EA = (An)
base relative	EA = (An) + d16
indexed	EA = (An) + (An) + d8
PROGRAM COUNTER RELATIVE	
relative with offset	EA = (PC) + d16
relative indexed	EA = (PC) + (An) + d8
start PC relative branch	EA = (PC) + d8
long PC relative branch	EA = (PC) + d16
ABSOLUTE ADDRESSING	
absolute short	EA = (next instruction word)
absolute long	EA = (next two instruction words)
IMMEDIATE DATA ADDRESSING	
immediate	DATA = next instruction word
quick immediate	DATA = subfield of instruction (4 bits)
DEFINITIONS	
EA	= effective address
An	= address register
Dn	= data register
Xn	= address or data register used as index register
SR	= status register
PC	= program counter
d8	= 8-bit displacement
d16	= 16-bit displacement
N	= 1 for byte, 2 for word, and 4 for long word (operands)
()	= contents of
←	= replaces

data be word aligned. Bits are individually addressable in the bit-manipulation instructions.

The architecture specifies an optimal memory management scheme that implements and enforces variable-length segmentation of the address space with access rights specifiable for individual segments. The processor can be used with or without memory management.

Address calculations (Table 2) are specified by 6-bit fields of the instruction. The addressing specification is orthogonal to the operation specification of the instruction; that is, any addressing mode can be used in any instruction that uses addressing.

Addresses are 32-bit quantities (24 bits in the current implementation). The architecture efficiently supports small systems (those with fewer than 2^{16} addressable bytes) by allowing 16-bit address quantities to be specified, moved, or calculated in almost every addressing situation. For example, an absolute address carried in an instruction can use 16 or 32 bits, or an index calculation can use 16 bits (sign extended to 24 bits) or 32 bits of a register as input. This feature allows the architecture to support very large addresses without penalizing the efficiency of programs that require only small addresses. The address size (16 or 32 bits) is individually specified for each use, so that large and small addresses can be intermixed arbitrarily in a program.

A variety of addressing modes are available:

Register direct. The data or address register contains the operand.

Address register deferred. The operand address is in the specified address register.

Address register deferred post-increment. The operand address is in the specified address register. After the operand is accessed, the address in the register is incremented by the operand size (1, 2, or 4).

Address register deferred pre-decrement. The operand address is in the specified address register. Before the operand is accessed, the address register is decremented by the operand size.

Base relative. The operand address is the contents of the specified address register plus a 16-bit signed displacement in the instruction.

Program counter relative. The operand address is the current program counter value plus a 16-bit signed displacement in the instruction.

Indexed. The operand address is the contents of the specified address register plus the contents of an additional (data or address) register specified plus an 8-bit signed displacement in the instruction.

Program counter indexed. The operand address is the current value of the program counter, plus the contents of the specified data or address register, plus an 8-bit signed displacement in the instruction.

Absolute. The operand address is in the instruction.

Immediate. The operand is in the instruction.

Bit addressing. A complete set of bit manipulation instructions (AND, OR, XOR, CLEAR, and TEST) is provided. For these instructions, an individual memory word is addressed using one of the above addressing modes. The individual bit to be manipulated is addressed by its bit number in that word. The bit specification is contained in the instruction or previously calculated in a data register. This mechanism allows bits to be addressed directly, without requiring the use of logical instructions and masks. For registers, all 32 bits are individually accessible.

In all cases, the addresses specified by the program can span the entire address space. No arbitrary segment sizes are imposed, and no separate segment numbers need be manipulated.

Address, like integer, is a fully supported data type. A complete set of address-manipulation operations (MOVE, COMPARE, INCREMENT, DECREMENT, ADD TO, SUBTRACT FROM) is implemented on the address registers. In addition, the LOAD EFFECTIVE ADDRESS instruction performs an arbitrary calculation and puts the result into a specified address register. This provides the programmer, in a single instruction, with the ability to precalculate addresses using any of the processor's addressing modes.

Because there are eight address registers, fewer memory accesses are required for loading and storing temporary address values, and addresses rarely need to be recalculated in different parts of the program. These features minimize the program time spent manipulating addresses, a common bottleneck in existing microprocessors. They also establish a degree of address-size independence: the address-specification fields in instructions are most often only 6 bits, regardless of the fact that a large 32-bit address is actually being specified.

Data manipulation. The 68000 supports a number of data types and supplies a complete set of operations for each type (Table 3 and Figure 3). In general, the addressing mode is independent of the data type. Also, in cases where it makes sense (operands and addresses), the size of the operand may be specified independently of the operation. Operand sources may be either registers or addressed memory locations. The result may be stored either in the register or in the specified memory location. This class of "register-to-memory" operations reduces the number of register stores required to save results. Most operations can be specified to work memory-to-register, register-to-register, register-to-memory, immediate-to-register, or immediate-to-memory. The move instruction is more flexible, being a full two-address instruction. It can specify memory-to-memory move operations as well as the options listed above.

ADD REGISTER DEFERRED

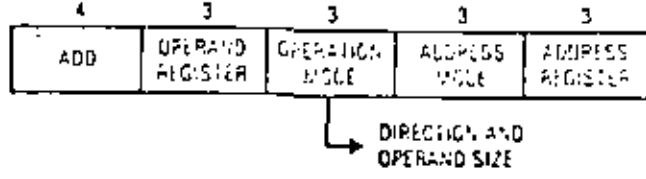

ADD INDEXED

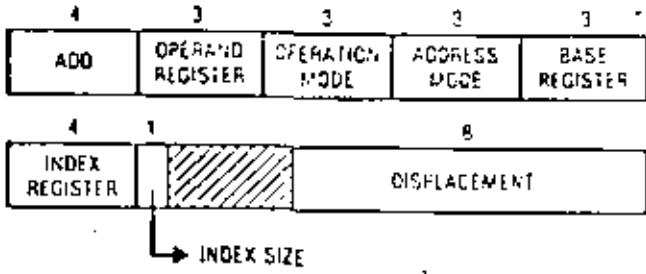

MOVE



CONDITIONAL BRANCH

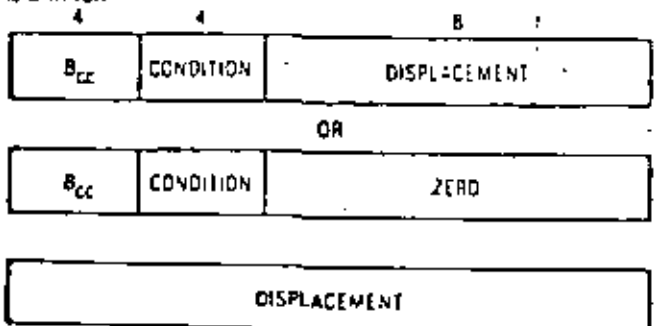

Figure 3. Typical 68000 instruction formats.

The 68000 data types and the operations that support them are:

Integer. The operations are ADD, SUBTRACT, MULTIPLY, DIVIDE, NEGATE, COMPARE, and ARITHMETIC SHIFT. Integers may be 1, 2, or 4 bytes. Shifts are multiple bit shifts, either left or right, with shift count specified in the instruction or previously calculated in a data register, and indicate overflow as appropriate.

Multiprecision integer. ADD WITH EXTEND, SUBTRACT WITH EXTEND, NEGATE WITH EXTEND, UNSIGNED MULTIPLY, and UNSIGNED DIVIDE are the primitives supplied for easily implementing multiprecision integer arithmetic. Operands may be 1, 2, or 4 bytes, except for multiply and divide, which operate only on 2-byte quantities.

Logical. The operations are AND, OR, EXCLUSIVE OR, COMPLEMENT, COMPARE, SHIFT, and ROTATE (which allow multiple-position shifts and rotates, left or right, with or without extend bit). Logicals may be 1, 2, or 4 bytes.

Boolean. AND, OR, EXCLUSIVE OR, COMPLEMENT, IMPLICATION, and SET ACCORDING TO CONDITION CODES are provided. (SET ACCORDING TO CONDITION CODES is used to retrieve the logical value of any of the conditional tests that are available to the CONDITIONAL BRANCH instruction.) Boolean data are one-byte quantities.

Bit. The operations are SET, CLEAR, CHANGE, and TEST. Bits are individually addressable.

Decimal. ADD, SUBTRACT, NEGATE, and COMPARE are decimal operations. The decimal (BCD) instructions work on operands in memory (memory-to-memory) two digits (one byte) at a time. Combined with a looping instruction, the decimal instructions implement variable-length memory-to-memory decimal operations.

Character. Character instructions, MOVE and COMPARE, work on operands in memory (memory-to-memory).

Address. Address operations include INCREMENT (by 1, 2, or 4), DECREMENT (by 1, 2, or 4), ADD INTEGER, SUBTRACT INTEGER, COMPARE, and LOAD EFFECTIVE ADDRESS.

Real. Floating-point ADD, SUBTRACT, MULTIPLY, and DIVIDE are specified but not implemented in the first version.

String. STRING MOVE, STRING SEARCH, and TRANSLATE are specified but not implemented in the first version.

Program control. Program control instructions include CONDITIONAL BRANCH (program counter relative), JUMP, JUMP TO SUBROUTINE, RETURN FROM SUBROUTINE, and RETURN FROM INTERRUPT, all of which are traditional instructions. Sixteen separate operating-system calls are specifiable with the TRAP instruction. Conditional traps, looping, and subroutine control are discussed below. The STOP instruction halts the processor, the RESET instruction reinitializes the system environment, and the MOVE instruction can manipulate the processor status word.

Privilege states. The 68000 processor can operate in user or supervisor state. In supervisor state, the entire instruction set is available. Indication of the current state is given to the external world so that, for instance, address translation can be inhibited when the processor is in supervisor state. In user state, certain instructions, such as STOP, RESET, and those that modify the status word, are not allowed. They cause a

Table 3.
MC68000 instruction set.

MEMORNIC	DESCRIPTION
ABCD	Add decimal with extend
ADD	Add
ADDX	Add with extend
AND	Logical and
ASL	Arithmetic shift left
ASR	Arithmetic shift right
BCC	Branch conditionally
BCHG	Bit test and change
BCLR	Bit test and clear
BRA	Branch always
BSET	Bit test and set
BSP	Branch to subroutine
BST	Bit test
CHK	Check register against bounds
CLR	Clear operand
CMPI	Arithmetic compare
DCNT	Decrement and branch non-zero
DIVS	Signed divide
DIVU	Unsigned divide
EXOR	Exclusive or
EXG	Exchange registers
EXT	Signed extend
JMP	Jump
JSR	Jump to subroutine
LDM	Load multiple registers
LDD	Load register quick
LEA	Load effective address
LINK	Link stack
LSL	Logical shift left
LSR	Logical shift right
MOVE	Move
MULS	Signed multiply
MULU	Unsigned multiply
NECD	Negate decimal with extend
NEG	Two's complement
NEGX	Two's complement with extend
NOP	No operation
NOT	One's complement
OR	Logical or
PEA	Push effective address
RESET	Reset external devices
ROTL	Rotate left without extend
ROTR	Rotate right without extend
ROTXL	Rotate left with extend
ROTXR	Rotate right with extend
RTR	Return and restore
RTS	Return from subroutine
SECD	Subtract decimal from extend
SCC	Set conditionally
STM	Store multiple registers
STOP	Stop
SUB	Subtract
SUBX	Subtract with extend
SWAP	Swap data register halves
TAS	Test and set operand
TRAP	Trap
TRAPV	Trap on overflow
TEST	Test
UNLK	Unlink stack

SAMPLE PROGRAM.

```

PROGRAM EXAMPLE:
VAR PARAM1, PARAM2 INTEGER;
PROCEDURE PROC (X: INTEGER, VAR Y, INTEGER);
  VAR A, B INTEGER;
  BEGIN
    <procedure body>
  END;
BEGIN
  PROC (PARAM1, PARAM2)
END.

```

PROGRAM BODY:

```

MOVE   PARAM1 TO -SP@    "push first parameter"
PEA    PARAM2            "push address of 2nd parameter"
JSR    PROC              "call the procedure"
ADD    #6 TO SP         "pop parameters from the stack"

```

PROCEDURE BODY:

```

LINK   FP, 4            "link and allocate three local
                        variables"
MOVEM  <register(s)> TO -SP@ "push some register contents"
<procedure body>
MOVEM  <register(s)> FROM SP@ + "restore registers"
UNLK   FP              "restore stack"
RETURN "return to calling procedure"

```

Figure 4. Sample Pascal program and equivalent 68000 code.

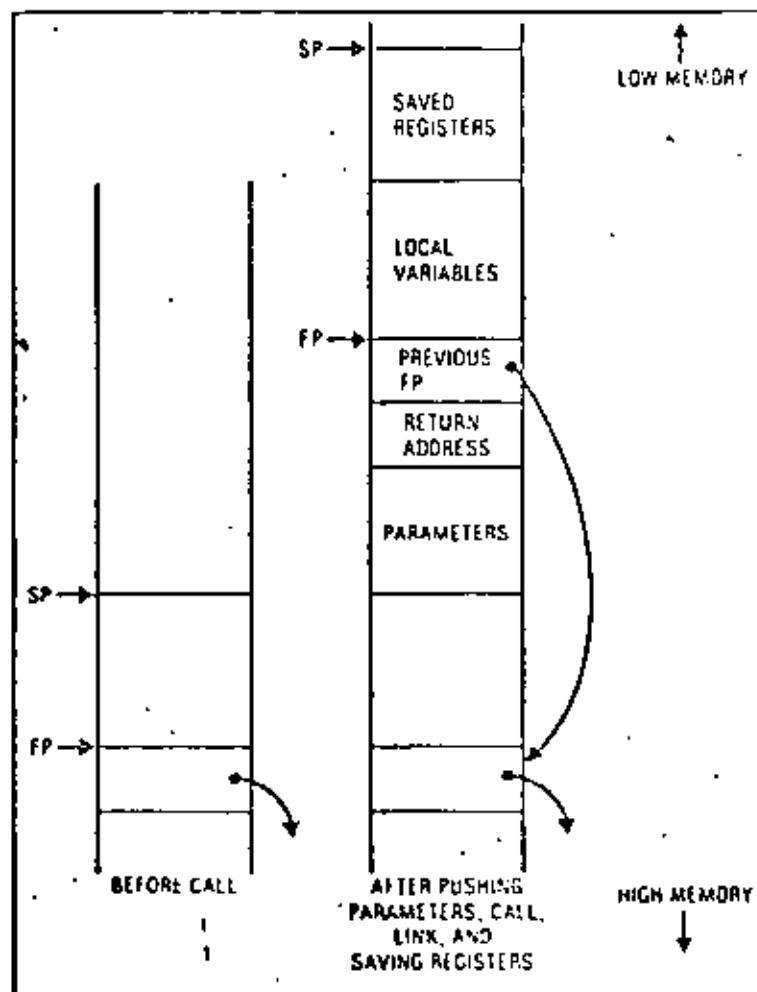

Figure 5. Stack activity on procedure call.

trap to supervisor state (by stacking the current program and status word and loading a new context from a pre-assigned trap vector). Illegal instructions, unimplemented instructions, interrupts, and traps (operating as system calls) all cause the processor to trap and switch to supervisor state. To ensure proper operation when returning to supervisor state, regardless of user-state activity, there are two stack-pointer registers—one active in user state, one in supervisor state. The user stack-pointer contents are available, by special instructions, to the supervisor-state program.

The 68000's user/system state distinction will allow a small operating-system kernel to provide fully protected virtual address spaces to any number of independent tasks or users.

Trapping on illegal and unimplemented instructions allows the operating system to provide a more functional virtual machine to user-state tasks. For instance, the operating system can transparently provide software implementation of any currently unimplemented instructions (such as floating-point or string manipulation) executed by a user-state task.

High-level language support. A recent paper by Allison⁸ suggests ways in which microprocessor architecture should be designed to support high-level languages. This method, followed by the 68000 designers, is to "examine the runtime representation required for the class of languages to be implemented" and to "provide adequate instructions... to support the required runtime representation" and transformations on that representation "without extensive in-line computation."

The 68000 design supports high-level languages, at both compilation time and execution time, with a clean, consistent instruction set; with hardware implementation of commonly used functions (multiply, divide, and address calculation); and with a set of special-purpose instructions designed to manipulate the runtime environment of a high-level language program. The language constructs aided by these special-purpose instructions include array accessing, limited-precision arithmetic, looping, Boolean-expression evaluation, and procedure calls.

Array accessing. The BOUNDS CHECK instruction compares a previously calculated array index (in a data register) against zero and a limit value addressed by the instruction. A trap occurs if the index is out of bounds for that array. This replaces a common sequence of instructions (at least four) with a single instruction.

Limited-precision arithmetic. The TRAP ON OVERFLOW instruction causes a trap if the previous operation resulted in overflow. This allows efficient overflow testing to encourage proper checking of arithmetic results.

Looping. A restricted form of the FOR-loop construct is implemented in a single instruction that decrements a count and branches backward if the result is nonzero.

Boolean expression evaluation. The CONDITIONAL SET instructions assign a true or false value to a Boolean variable on the same conditions that are us-

ed by the **CONDITIONAL BRANCH** instructions. These instructions help implement Boolean-expression evaluation by avoiding extra conditional branches, especially in the case (as with Pascal) where "short-circuited" evaluation may be undesirable because of possible side effects.

Procedure calls. The 68000 uses a stack—pointed to by one of the address registers, called the stack pointer—to build the nested environments of called procedures. Three instructions (plus an additional one for each parameter) implement a high-level-language procedure call (Figure 4). The entire call mechanism uses only the stack and is completely reentrant (Figure 5). These instructions are described in more detail below.

Push parameter values or addresses onto the stack. The **MOVE** instruction pushes a value onto the stack, and the **PUSH EFFECTIVE ADDRESS** (see **LOAD EFFECTIVE ADDRESS** explained earlier) pushes the result of an arbitrary address calculation onto the stack for call by reference.

Call procedure. The **JUMP TO SUBROUTINE** instruction pushes the return address on the stack and jumps to the procedure entry point.

Establish new local environment. The **LINK** instruction does all of the following: saves the old contents of the frame pointer (an arbitrary address register) on the stack, points the frame pointer to the new top of stack, and subtracts the number of bytes of local storage required by the procedure from the stack pointer. This establishes local storage for the called procedure and a frame pointer (address register) for index addressing of local variables and parameters.

Save an arbitrary subset of the registers on the stack. The **MOVE MULTIPLE REGISTERS** instruction saves an arbitrary subset of the registers on the stack (or anywhere in memory) in a single instruction. The registers to be saved are indicated by setting the corresponding bits in a 16-bit field of the instruction.

A set of at most four instructions reverses the process for procedure return:

Reload saved registers. The **MOVE MULTIPLE REGISTERS** instruction is used here also.

Reestablish previous environment. The **UNLINK** instruction undoes the work of the **LINK** instruction.

Return from procedure. The **RETURN** instruction pops the return address from the stack and returns to the calling procedure.

Pop parameters from the stack. The **ADD IMMEDIATE** instruction used on the stack pointer pops any number of values off the stack.

The 68000 system architecture

A computer architecture specifies interactions between the processor and its environment by defining such things as interrupt structure, memory segmentation, bus interfaces, and input/output structure. The 68000 system architecture is designed to be as flexible as possible. For instance, I/O device registers are addressed as memory locations (memory-mapped

I/O), as on other Motorola microprocessors. Memory-mapped I/O gives the programmer the flexibility and power of the entire instruction set for manipulating device control and data registers. Since no additional instructions are required for I/O, the processor is simpler, and the instruction set is easier to remember. The I/O space is protected by the same memory-management facilities that are used to protect critical areas of memory.

The 68000 bus structure is also designed for simplicity, speed, and flexibility. The address and data lines are separate; no multiplexing is needed. This avoids the need for any separate devices for demultiplexing, ensuring maximum performance for systems in which speed is important. The bus is asynchronous; transfers on the bus are controlled by accompanying handshake signals, so that no assumptions need be made about timing or system synchrony. The use of handshake signals allows devices and memories with large variations in response time to be used on the same processor bus. The processor waits an arbitrary amount of time until the ordered device or memory signals that the transfer is occurring.

A simple bus request/grant protocol is implemented on chip so that processors and direct-memory-access devices can cooperatively share the system bus with no extra arbitration logic. Also, the chip has a bus-fault input pin that causes instruction execution to be terminated at any point and that can be taken if an illegal or faulty memory access is made. This facilitates memory protection.

The 68000 interrupt structure is like that of most minicomputers. Eight priority levels are implemented. Interrupts are vectored so that software has full control over the placement and execution of interrupt-handling routines. The current priority level of the processor is kept in its status word; interrupts at or below the current priority are inhibited. Interrupts at higher levels may occur, so interrupt handling may be nested. When an enabled interrupt occurs, the processor sends an acknowledge signal. The interrupting device responds with a vector number. The vector number is used by the processor

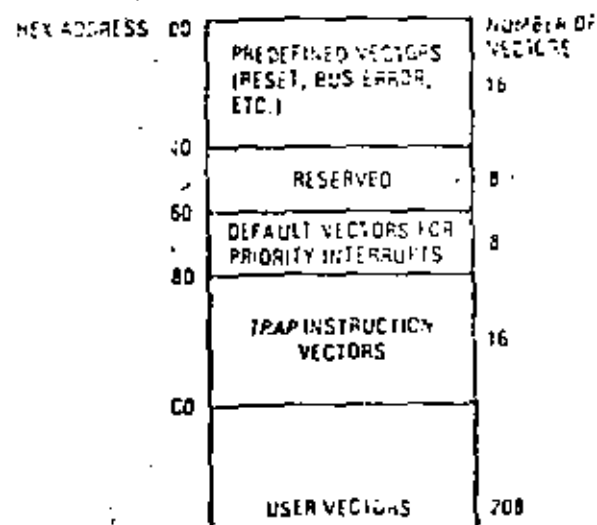

Figure 6. Trap and interrupt vector allocation.

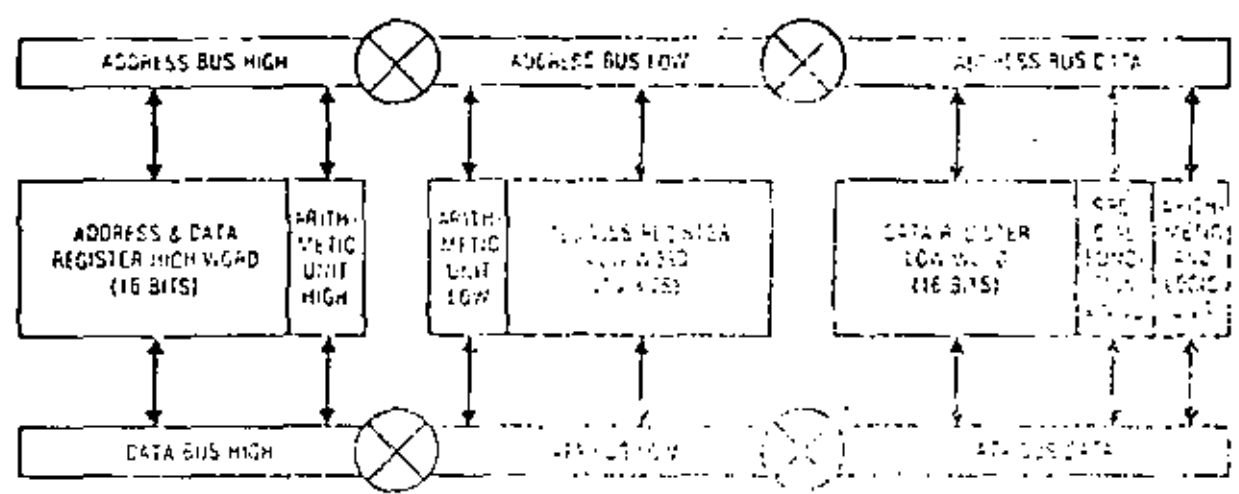

Figure 8 MC68000 execution unit configuration

of circuit area and permits logic gates to be designed with a speed-to-power product of one picosecond. An advanced high-density 1- μ m channel silicon gate CMOS technology was selected for the design of the MC68000. This technology supports three different gate geometries and provides the designer with a wide range of MOS transistor threshold voltages. The technology also allows the circuit designer to develop high performance logic gates using minimum area and power, and to develop internal buffers with low static power.

The processor unit is divided into three functional forms both address and data processing units. The two buses are 16 bits wide and can be dynamically reconfigured into three configurations as required by the microcode. Three independent arithmetic units are available to perform these calculations, also, special logic functions are provided to execute long shifts, priority encoding, and bit manipulation. Each of these units is connected to two internal buses and receives both input operands simultaneously from the registers. Each bus serves both the true and the complement logical values. A differential circuit design can be used for high speed operation. The execution unit directly interfaces to the external bus logic and buffers, but its operation is independent of the external timing requirements of the bus.

The control of the 68000 is implemented by microcode. The actual structure of the microprogram control structure is discussed in detail in another paper.⁸ The microcontrol is implemented as a two-level structure. The first level contains a series of microinstructions with short "vertical" control words, complex branching capabilities. Microinstructions contain the addresses of nanoinstructions. The "horizontal" control words, stored in the second level. The nanoinstructions directly control the execution unit. The use of microcode is motivated by the high design cost of new VLSI chips. The microcode's regularity of structure compared to combinatorial logic significantly decreases the design complexity. Microcode also permits some engineering decisions—for instance, details of specific instructions—to be delayed. In other words, once the micro-machine architecture is determined, hardware

design decisions are deferred until the microcode has been created. This is a significant advantage of microcode.

REFERENCES

1. "Microcode," *IEEE Computer Graphics and Applications*, Vol. 1, No. 1, pp. 40-47, 1979.
2. "Microcode," *IEEE Computer Graphics and Applications*, Vol. 1, No. 1, pp. 48-55, 1979.
3. "Microcode," *IEEE Computer Graphics and Applications*, Vol. 1, No. 1, pp. 56-63, 1979.
4. "Microcode," *IEEE Computer Graphics and Applications*, Vol. 1, No. 1, pp. 64-71, 1979.
5. "Microcode," *IEEE Computer Graphics and Applications*, Vol. 1, No. 1, pp. 72-79, 1979.
6. "Microcode," *IEEE Computer Graphics and Applications*, Vol. 1, No. 1, pp. 80-87, 1979.
7. "Microcode," *IEEE Computer Graphics and Applications*, Vol. 1, No. 1, pp. 88-95, 1979.
8. "Microcode," *IEEE Computer Graphics and Applications*, Vol. 1, No. 1, pp. 96-103, 1979.

THE MICROPROCESSOR

FOR THE MICROSYSTEMS



Microcode is a key element in the design of microprocessors. It provides a flexible and powerful means of controlling the processor's operation. The use of microcode allows the designer to implement complex control logic in a simple and efficient manner.

For more information, contact
 Intel Corporation, Santa Clara, CA 95051
 or call (415) 351-1000.

Further details, including a complete data sheet, are available from:
 David Bull Microprocessors and Microsystems,
 Westbury House, Bury Street,
 Guildford, Surrey GU2 5AU, England

Telephone: (01483) 512611 Telex: 950151515
 Fax: (01483) 512612

only by high-end minicomputers. It is a 32-bit architecture that supports many data types and data sizes. The advantages of the 68000 include a flexible addressing mechanism, a simple and effective instruction set that can be used to easily build complex operations, a multilevel vector interrupt structure, and a fast, asynchronous, nonmultiplexed bus architecture. The 68000 architecture describes a family of microprocessors designed for the expanding high-end microcomputer market. ■

8 D. R. Allison, "A Design Philosophy for Microcomputer Architectures," *Computer*, Vol. 10, No. 2, Feb. 1977, pp. 35-41.

9 E. P. Senter and H. L. Froelich, "The Programmed Implementation of a Single-Chip Microprocessor," *Proc. 11th Annual Microprogramming Workshop*, Nov. 1978, pp. 8-16.

References

1. J. R. Battner, "Microprocessor Architecture: Where Do We Go From Here," *COMCON Spring 1977 Digest of Papers*, pp. 223-224.

2. F. P. Brooks, "An Overview of Microprocessor Architecture and Software," *Proc. EUROCOM'78*, 1978, North Holland, pp. 1-6.

3. C. G. Hell and W. D. Stricker, "Computer Structures: What Have We Learned From the 1970's?," *Proc. 2nd Symposium on Computer Architecture*, 1974, pp. 3-13.

4. L. A. Levant and W. C. Walsh, "Guiding Considerations in Microprocessor Design," *COMCON Spring 1977 Digest of Papers*, pp. 225-226.

5. B. J. Peoto and I. J. Sniestek, "Current Issues in the Architecture of Microprocessors," *Computer*, Vol. 10, No. 2, Feb. 1977, pp. 20-25.

6. S. A. Ward, "Toward the Renaissance Computer Architecture," *MIDCON 1977 Exprints*, pp. 1-6.

7. P. E. Stanley, "Address Size Independence in a 16-bit Minicomputer," *Proc. 5th Symposium on Computer Architecture*, 1978, pp. 152-157.

GENERAL TERMS and DEFINITIONS

Access Time (Read and/or Write)	The time interval between the instant data is inserted into or requested from memory and the instant that data transfer is completed (may be the longest path.)
Accumulator	A temporary storage register(s) that (stores) sums and other arithmetic and logical operations of an arithmetic logic unit (ALU.)
Address	A character or group of bits that identifies a particular location in memory, or other locations of data sources and destinations.
Addressing Modes	The methods of specifying the location(s) of data or program segments in memory or other locations.
Arithmetic and Logic Unit (ALU)	That part of a CPU that performs arithmetic, logical and related operations. Along with memory and control, an essential microprocessor element.
Architecture	The organizational structure of a computing system. Refers mainly to physical makeup of the micro-computer (Section 2) or microprocessor (Section 10) parts in this volume.
Assembler	A computer program used to translate a symbolic-language statement to a machine-language statement on a one-for-one basis.
Assembly Language	A programming language utilizing symbolic representation. The symbolic representation, sometimes called mnemonics, suggests the instruction function and is translatable by the assembler into machine language.
Asynchronous Operation	A switching network operation with no common timing source. Circuit operation is such that the completion of one event initiates the next.
Baud	A measure of serial data transmission flow in communications applications. Baud rate generally defines signal bits per second transmitted, but may also include character framing bits.
Benchmark Problem	A frequently used (sample) problem employed to compare and evaluate computers (microcomputers.) Permits comparison of the number of instructions, memory words, and operation cycles required to solve the same problem.
Binary Coded Decimal (BCD)	A number coding system in which each decimal digit is represented by a 4-bit binary word. The decimal number 13 becomes the coded-number 0001 0011 in BCD using an 8-4-2-1 binary code.
Bit	The abbreviation of "binary digit" and the single characters in a binary number (1 or 0).

GENERAL TERMS and DEFINITIONS

A decision-making capability that permits a processor to select one from a number of alternative sets of instructions depending on the data being processed.

A circuit employed to minimize the effects of a following circuit on the preceding circuit.

One or more conductors used for transmitting signals or power from one or more sources to one or more destinations.

A pre-determined binary element string (number of consecutive bits) operated on as an entity. A byte is usually but not necessarily 8-bits.

it The unit of a computing system that includes circuits controlling the interpretation and execution of instructions.

A generator of periodic signals used to synchronize circuit operations.

A computer program used to translate a high-level language program (e.g.,) FORTRAN) into a computer oriented (assembly or machine) language program.

A group of program conditions such as carry, borrow, overflow, etc. that are particularly relevant to instruction execution.

A bus carrying the signals that regulate system operation within and without the computer.

A sequence of instructions that directs the central processing unit (CPU) in the various operations it performs.

A computer program used to translate symbolic-language programs assembled on one computer into machine-language programs that operate on another computer.

A method of interrupt priority in which the interrupt bus is searched serially.

A bus used to communicate data internally and externally to and from the CPU, memory, and peripheral devices.

A register holding the memory address of the operand used by an instruction. The data pointer "points" to the memory location of the (data) operand.

GENERAL TERMS and DEFINITIONS

Data Register	Any register that holds data.
Debug (Program)	A computer program designed to aid in detecting, tracing and eliminating errors in microcomputer (or other computer) programs while they are running. Allows replacing, adding, or revising instructions into the main operating program.
Decrement	A program instruction that decreases the contents of a storage location.
Dedicated Microprocessor	A microprocessor that has been programmed for a specific, single application.
Diagnostic Program	A computer program designed to check the operation of various hardware and software parts of the microcomputer system. Typically written for each functional area; e.g., CPU diagnostics for CPU checks, Memory diagnostics for Memory checks, etc. . .
Direct Addressing	An addressing mode in which the address of the instruction or operand is completely specified in the instruction without reference to a base register or index register.
Direct Memory Access (DMA)	A method of inserting input/output data into storage or obtaining input/output data from storage directly, without involving the usual flow of data through the processor registers.
Editor (Program)	A computer program designed to allow manipulation of source program text material.
Emulate	To imitate one system with another, the latter being microprogrammable and equipped with a special microprogram, so that the imitating system executes the same programs and achieves the same results as the imitated system. (See Simulate.)
Execution Time	The time, normally expressed in clock cycles, required to carry out an instruction.
Fetch	The reading out of an instruction from main memory and the insertion of the instruction into working memory.
Firmware	Programming instructions stored in a read-only-memory (ROM.)
Flag Bit	An information bit that indicates the occurrence of special conditions such as — overflow, carry, interrupt.
Flow Chart	A graphical representation of a problem and the operations to be accomplished to solve the problem.
FORTRAN	A high-level programming language used to facilitate the expression of computer programs in arithmetic terms and formulae. Short for "Formula Translator."
Handshaking	A colloquial term that describes the method used by a modem (or other asynchronous devices) to establish a communication link for eventual data transmission.

GENERAL TERMS AND DEFINITIONS

A problem-oriented programming language where a single functional statement may translate into a series of instructions in machine language (a low-level language.) FORTRAN, COBOL, and BASIC are common high-level languages.

A program instruction that increases the contents of a storage location.

An addressing mode in which the operand is located in the instruction itself, or the memory location immediately following the instruction.

A register that provides a programming flexibility in that the information it contains can be used to modify memory address by addition or subtraction.

An addressing mode in which the address portion of an instruction is modified by an index-register during instruction execution. A means of changing an instruction address on the basis of external commands.

An addressing mode that specifies a memory location containing the address of data and not the data itself.

In a programming language, an expression that defines a computer operation and identifies its operands.

The time required in fetching an instruction from memory and executing it.

The measure of the memory space required to store an instruction.

The total list of instructions that can be executed by a given microprocessor.

A program that fetches and immediately executes instructions written in a higher level language. (See Compiler and Assembler.)

An external signal that temporarily suspends the normal program operation in order to permit processing of a high-priority operation. Multiple interrupt capability requires establishment of an interrupt priority system.

General term applied to equipment and/or data involved in connecting the central processing unit (CPU) with the outside world. The control electronics necessary to tie the computer to various external application areas.

A connection to a central processing unit (CPU) wired or programmed to connect data between the CPU and external devices, i.e., keyboard, display, card reader, etc. May be an input, output, or bidirectional port.

Jump	An unconditional departure from the normal instruction sequence to a different place in the program.
Loader (Program)	A computer program designed to read (enter) a program from an input device into working storage. (Random Access or Read/Write Memory – RAM.)
Look Ahead	A central processing unit (CPU) feature that allows the computer to mask (ignore) an interrupt request until the following instruction has been executed.
Loop	A sequence of instructions in which the final instruction causes repetition of the sequence a number of times until a termination condition as detected by a branch instruction is reached.
Machine Language	The numeric form of specifying every bit of every instruction in a program. The final binary code that a computer uses directly.
Machine Cycle	The basic central processing unit (CPU) cycle in which, an address may be sent to memory and a word (data or instruction) may be read or written; or in which a fetched instruction may be executed. One machine cycle is made up of several clock cycles.
Macro Instruction	A symbolic source assembly language statement that combines any group of frequently used commands (instructions). The macro instruction will be expanded by the assembler into several machine language instructions.
Memory Address Register	The register in the central processing unit (CPU) that contains the address of the storage (memory) location being accessed.
Microcomputer	A computer system whose central processing unit (CPU) is a microprocessor. A basic microcomputer includes a microprocessor, memory, and input/output facility.
Microinstruction	An element in a microprogram.
Microprocessor	A single integrated circuit chip, or set of chips, capable of performing the functions of a central processor.
Microprogram	The computer instructions stored in a read-only memory (ROM) that implement the basic instruction set of the computer.
Microprogrammable Computer	A computer in which the microprogram (microinstructions) in the read-only memory (ROM) can be changed, thus changing the computer's instruction set.

GENERAL TERMS and DEFINITIONS

Symbolic names or abbreviations for instructions, registers, memory locations, etc., suggesting the definition or function thereof.

Devices or equipment employed to interface data processing equipment with communication lines.

Simultaneous execution (by use of multiple CPU's operating with a common memory) of multiple programs by one computer.

Calling a subroutine from, or enclosing a program loop within, a larger routine or loop. For a subroutine the nesting level is the number of times the subroutine is nested.

The output from a compiler or assembler which is itself executable machine code or is suitable for processing to produce executable machine code.

The field of the instruction that represents the specific operation to be performed.

The data with which a mathematical or other operation is performed.

A computer program that controls the overall operation of a computer system, including such things as memory allocation, input/output distribution, interrupt processing, job scheduling, etc.

A bit in the condition code register that indicates if the previous operation in the program caused an arithmetic overflow, i.e., caused a quantity to be generated that exceeded the capacity of the results register.

A natural grouping of memory locations, e.g., 2⁸-256 consecutive bytes in an 8 bit microcomputer may typically constitute a "page" of memory.

The processing of all the bits of a word (byte) simultaneously by transmitting on separate channel or bus lines.

Auxiliary equipment (in the outside world) used to enter data in and receive data from a (main) computer.

Temporary suspension of a microcomputer program to permit execution of a program or part of a program of higher priority.

Central processor unit (CPU) registers that contain memory addresses. Sometimes called Data Pointers or Program Counters.

A method used to identify the source of an interrupt request. In polling, the interrupt request search is done serially.

GENERAL TERMS and DEFINITIONS

Port (I/O Port)	Terminals that provide electrical access between the (micro)computer and the outside world.
Program Counter	A register in the central processing unit (CPU) whose job is to step the (micro)computer through the (micro)program. This register holds (saves) the address of the instruction under execution in the event of program interrupt or branching activity.
Programmable Logic Array (PLA)	An array of logic elements whose interconnections can be programmed (usually mask programmed, some field programmable) to perform a specific logical function.
Programmable Read-Only Memory (PROM)	A memory array manufactured with a constant logical pattern (all ones or zeros) and that can be written into (programmed) by the user. EAROM's (electrically alterable ROM's) can be electrically erased and reprogrammed. EPROM's can be erased and reprogrammed using ultraviolet light and electrical signals.
Push Down Stack	See "Stack."
Random Access Memory (RAM)	A memory device that has read and write capability and that provides direct access to stored information, regardless of location. Read or write time is independent of data location.
Read	To acquire and/or to interpret data from a memory device.
Register	Small scale memory capable of holding a fixed amount of data, such as a word. Used mainly as temporary storage, and accessible to the central processing unit (CPU.) The number of registers in a microprocessor is directly related to the program efficiency.
Relative Addressing	An addressing mode in which the address is determined by adding an offset address to a base address stored in some register. Permits the computer to relocate blocks of data by changing bits one number.
Read-Only-Memory (ROM)	A memory device generally used to store a computer's control programs (firmware), and not alterable by normal operating methods. Exceptions are PROM's, EPROM's and EAROM's, which are ROM's whose contents may be altered in the field by special means.
Scratch Pad Memory	Read/Write (RAM) memory devices or registers that are used to store temporarily intermediate results (data), or memory addresses (pointers.)
Simulate	To imitate one system with another using a program written in assembly or high level language so that the imitating system accepts the same data, executes the same programs, and accomplishes the same results as the system being imitated. (See Emulate.)
Slice	A partition of a microprocessor that enables several identical units to be paralleled or cascaded and augmented by control logic to realize the CPU.
Software	A collection of computer programs, procedures, rules and documentation used or associated with the operation of the computer.

GENERAL TERMS and DEFINITIONS

8

A computer program in a high-level or assembly language.

A sequence of registers or memory storage locations accessible in a last-in-first-out (LIFO) basis.

The counter or register that addresses the current stack location.

A computer system that is complete within itself and does not require connection to another computer system to operate.

A group of instructions (subprogram) that may be reached from more than one place in a main program with a branch back to the source point when the subprogram task is completed.

n Circuit operation using a common timing source (clock) to time circuit or data transfer operations.

See "Branch Instruction"

A device used in communications applications to interface (connect) a word parallel data terminal (controller) to a bit serial communication network.

An interrupt system in which each interrupt can be immediately serviced without having to determine which interrupt has occurred by polling.

In a given (micro)computer, the most common storage entity for instructions and data.

To record data.

Programa para contar frecuencia de una señal externa con CTC

Cortar ondas en Canal 1 CLK/TRG por 1/10 seg. usando canal 2 con 4 interrupciones, cada una de $195 \cdot 256 / 1.024 \times 10^6 = .025$ seg. Para probarlo, usar canal 0 salida ZC.

Programa Principal

2060	ZP 05	TRG, 05	Feloi/16, no interrup.
	DZ 84	OUT (04), 4	Canal 0
	ZP 90	TRG, 90	120*16 ciclos = 025 Hz
	DZ 84	OUT (04), 4	
2062	ZP 50	TRG 0	
	ZP 20	TRG, 20	Byte más significativo
	DZ 47	TRG, 4	Registro T
	ZP 88	TRG, 88	Byte menos significativo
2070	DZ 84	OUT (04), 4	Se escribe en canal 0
	ZP 45	TRG, 45	Feloi/256, permitir int.
	DZ 87	OUT (87), 4	Canal 2
	ZP 07	TRG, 07	Constante de tiempo=105
	DZ 87	OUT (87), 4	
	ZP 55	TRG, 55	Modo contador, no int.
	DZ 85	OUT (85), 4	Canal 1
	ZP 05	VOP 4	Parar 1
	DZ 85	OUT (85), 4	Constante de tiempo
2071	Z2 80 23	IP (DIRECTA+8), 4	Cero en TRG No. 8
	DZ 89	ZVY	Cargar registros altern.
	DZ 00	TRG, 55	Cuenta inicial
	DZ 04	TRG, 04	Cuatro interrupciones
	DZ 00	ZVY	
	DZ 00	BT	Permitir interrupciones
	DZ 84 00	IP DISUP	Monitor despliegue
2080	DZ 20		Vector de int. canal 2

Programa de servicio de interrupciones

2090	DZ 00	ZY 15, 17	
	DZ 00	ZVY	
	DZ 05	TRG 0	Cortar interrupciones
	Z2 01 41	IP (DIRECTA+2), 4	
	DZ 04	TRG, 04	
	DZ 05	TRG, (05)	Cuenta nueva
	DZ 50	TRG, 4	Guardar en 8
	DZ 57	TRG, 4	Contar con 8
	DZ 48	VOP 4	Parar A y DISUP
	Z2 89 23	IP (DIRECTA+2), 4	
	Z2 73 23	IP (DIRECTA+2), 4	
2092	Z2 73 23	IP (DIRECTA+4), 4	
	Z2 21	IP DISUP	
	Z2 73 23	IP 4, (DIRECTA+4)	
	Z2 00	TRG 4	
	DZ 01	OP 4	Diso o favor?
	DZ 17	IP 0	No - continuar
	DZ 00	VOP 4	Si - Parar 1
2098	Z2 73 23	IP (DIRECTA+4), 4	

2001	21	21	23	T.D A, (DTS'P'+2)	
	20			T.M A	
	22	04		CP A	Diez o favor?
	23	00		JR C	No - continuar
	42			YOD A	Si - borrar A
	22	24	23	T.D (DTS'P'+2), 4	
	21	20	23	T.D A, (DTS'P'+2)	
2002	20			T.M A	
	22	20	23	T.D (DTS'P'+2), 4	
	19	08		JR 08	
	22	26	23	T.D (DTS'P'+2), 4	
	19	02		JR 02	
	22	28	23	T.D (DTS'P'+4), 4	
2000	14			T.M B	
	74			CP A	
	80			CP C	Igual a cuenta previa?
	20	02		JR 02, 2000	Repetir
	42			JR C, 2	Guardar nueva cuenta
	09			RY 12, 1121	Intercambiar registros
	09			RY 7	
	22			RT	Permitir interrupciones
	20	40		200	Retorno

Programa para Contar Interrupciones

Interrupciones: pulsos hacia arriba en ASTER. Despliega numero 1-99 en los LEDs.

2200	00 00		TM 2	
	30 00		LDI 00	Byte menos significativo
	02 02		OUT(02),A	del vector de inter.
	30 40		LDI 40	modo entradas
	02 02		OUT(02),A	Lado A control
	30 07		LDI 07	Se permiten interrupciones
	02 02		OUT(02),A	
	30 07		LDI 07	Byte mas significativo
2210	00 47		LDI 47	en registro I
	00		BT	UPU acepta interrupciones
	03 00 00		JP 0000	Retorno al monitor
0708	05 23			Vector en ROM
2206	03 20 22		JP 2200	
2220	00		RY 40, 40	Intercambiar registros
	00		RY	
	30 00 23		LDI (DISMEM+5),A	LED Buffer No. 6
	05 00		AND 00	
	30		INC A	
	00 04		CP A	Diez o mas?
	00 00		JP C, CONT	No
	40		YOR A	Si - borrar A
	32 00 23		LD(DISMEM+5),A	
2220	30 00 23		LDI (DISMEM+4),A	Incrementar 10's
	05 00		AND 00	
	30		INC A	
	32 00 23		LD(DISMEM+4),A	
	18 00		JP 00	
	32 00 23		LD(DISMEM+5),A	
	21 00 00		LD HL, 0000	Generar desconexión
2201	20	000	DEC L	
	20 00		JP NZ 000	
	25		DEC H	
	20 00		JP NZ 000	
	00		RY 40, 40	Permutar registros
	00		RY	
	00		BT	Permitir interrupciones
	00 40		RTI	Retorno

2044	32 01		LD 01		
	32 12 20		LD (2012), 1		
	10 00		LD 00		
2051	32 10 20		LD (2010), 1		
	10 02		LD 02		
	32 10 20		LD (2010), 1		
	34 10 20		LD (2010)		
	10 21 20 22		LD IV, 2220		Segundos
2060	00 05 20		CALL, 2220		LD buffer No. 5
	34 10 20		LD (2010)		Format para LD buffer
	10 21 20 22		LD IV, 2220		minutos
	00 05 20		CALL, 2220		LD buffer No. 3
	34 10 20		LD (2010)		
2070	10 21 22 22		LD IV, 2220		Horas
	00 05 20		CALL, 2220		LD buffer No. 1
	34 27 22		LD (2227)		LD buffer No. 1 = cero?
	30 05		LD 2, 05		
	30 10		LD 10		Aparar LD No. 1
	32 27 22		LD (2227), 1		
2081	00	000	LD 17, 1120		Intercambiar registros
	30		LD 17		
	32		LD 17		
	30 40		LD 17		Permitir interrupciones
2096	40	000	LD 17		Retorno
	36 00		LD 0, 1		Subrutina para format
	30 27 01		LD 07		4 bits ceros significativo
	00 20		LD (IV+1), 1		LD buffer
	00 20		LD 0		4 bits más significativo
2000	00 20		LD 0		
	00 20		LD 0		
	00 21 00		LD (IV+0), 0		LD buffer
	00		LD 0		Retorno

Programa de Reloj Digital

Reloj del sistema = 1.0058 MHz
 1.0058 MHz / 256 = 2900 Hz: contando 200 ciclos por interrupción y 20 interrupciones por segundo para incrementar segundos.

Programa Principal

2000	00 50	TR 2	Modo de interrupción 2
	01 20	TR 20	Byte más significativo
	02 47	TR 4	Registro T
	03 14	TR 14	Byte menos significativo
	04 84	OUT (84), A	Canal 0 CTC
	05 45	TR 45	Permitir int., reloj/256
	06 85	OUT (85), A	Canal 1 CTC
	07 08	TR 08	Constante de tiempo = 200
2010	08 85	OUT (85), A	
	09	MOV	Intercambiar registros
	0A 27	TR 2, 20	Número de interrupciones
	0B	MOV	
	0C	BT	Se permiten interrupciones
	0D 02 00	LD 02, 00	Monitor despliegue
2014	2020		Vector de interrupción

Programa de servicio de interrupciones

2010			Segundos en 200
2011			Minutos en 200
2012			Horas en 200
2020	08	MOV 17, A, 17	Intercambiar registros
	09	MOV	
	0A	MOV 2	Contar interrupciones
	0B 50	LD 17, 200	Continuar
	0C 27	TR 2, 27	20 interrupciones por seg.
	0D 10 20	TR 4, (2010)	Segundos
	0E	TR 4	
	0F 27	TR 4	Ajuste decimal
	10 60	CP 60	60-segundos?
	11 26	JP 0	No
2030	12	MOV 4	SI - guardar A
	13 10 20	TR (2010), A	
	14 10 20	TR (2010)	Minutos
	15	TR 4	
	16	TR 4	
	17 60	CP 60	60 minutos?
	18 14	JP 0	No
	19	MOV 4	SI - guardar A
	1A 10 20	TR (2010), A	
2041	1B 10 20	TR (2010)	Horas
	1C	TR 4	
	1D	TR 4	
	1E 17	CP 17	17 horas?
	1F 02	JP 0	No

2041	CR 7F		SRF, A	Correr bits 4-7
	CR 7F		SRI, A	
	CR 7F		SPI, A	
2050	CR 7F		SPI, A	
	DR 77 00		LD (IX), A	4 bits mas signif.
	3A 00 20		LD, (2000)	Rvte menos significativo
	06 0F		AND OF	
	DD 77 03		LD (IX+2), A	4 bits menos signif.
	3A 90 20		LD, (2000)	
2060	CR 7F		SRI, A	
	CR 7F		SPI, A	
	CR 7F		SPI, A	
	CR 7F		SPI, A	
	DR 77 02		LD (IX+2), A	4 bits mas signif.
	21 40 20		LD HL, 2040	LED buffer
	06 09		LD B, 09	LED No. 3
2070	5F	DRS	LD E, (HL)	
	15 00		LD B, 0	
	3F 00		LD A, 0	
	02 90		OUT (0290), A	Apagar LEDs
	DD 21 16 07		LD IX, 0216	Tabla de segmentos
	DD 19		AND IX, 0F	Posicion en la tabla
	DD 7F 00		LD A, (IX+0)	Codigo de segmentos
2080	03 98		OUT (0398), A	LED segmentos
	73		LD A, B	B indica LED numero
	02 90		OUT (0290), A	LED catodos
	1F 20		LD B, 20	0.6 usec. espera
	1D		DEC B	
	3F 00		LD A, 0	
	02		CP B	
	20 2A		LD B, 2	
	3F 01		LD A, 01	
	02		CP B	
2090	20 19		LD Z, 019	Terminado?
	23		LD B, 23	Recomenzar
	03 70		LD C, 70	Continuar
	19 09		LD B, 09	Siguiente LED
	00		LD DRS	
2090	07 20			Puerto A vector
2001	05 20			Puerto B vector

Programa para contar angulos usando convertidor incremental

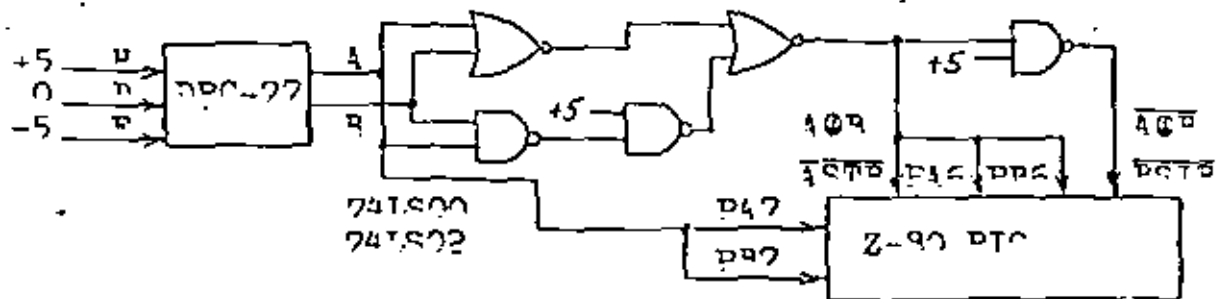

Rutina de servicio de interrupciones

2000	00	RY 47, A121	Interrupción lado A
	P0 01	TR 4, (R1)	Leer lado B
	10 03	JZ 02	
2005	00	RY 17, A121	Interrupción lado B
	P0 00	TR 4, (R0)	Leer lado A
	P0 00	RY	Guardar registros
	05 00	AND 00	Examinar bits 6,7
	00 0	CB 0	B = valor previo
	04 1420	JP 1, 2014	negativo?
	20 00	JP Z	Cero?
2011	13	INC 02	Ajustar angulo +
	10 01	JZ 01	
2014	10	DEC 02	Ajustar angulo -
	47	TR 0, 4	Guardar bits 6,7
	00 03 00 20	LD(2000), 02	Guardar angulo
	00	RY 17, A121	Intercambiar registros
	P0	RY	
	20	RT	Permitir interrupciones
	ED 4D	RRRT	Retorno

Programa Principal

2000	ED 07	TR 2	
	20 00	LD 00	Byte menos significativo
	07 02	OUT(00), A	Vector lado A
	20 01	LD 01	
	07 02	OUT(01), A	Vector lado B
	20 40	LD 40	Modo entradas
	07 02	OUT(20), A	Lado A
	07 02	OUT(02), A	Lado B
2020	20 07	LD 07	Permitir interrupciones
	02 02	OUT(02), A	Lado A
	07 02	OUT(07), A	Lado B
	20 20	LD 20	Byte más significativo
	07 47	LD 47	Registro T
	00	RT	Permitir interrupciones
	00 21 10 20 200	LD 10, 2010	100 buffer
	20 00 20	LD 1, (2000)	Byte más significativo
2040	07 07	LD 07	6 bits menos signif.
	07 07 01	LD (17+1), A	
	20 20 20	LD 2, (2000)	

Programa para Control de un Motor de Paso Superior UC-25 8

Cuenta Inicial: Registros 00 Cuenta Final: Registros 00
 Bobinas del motor conectadas a PIO DPO-DPX por amplificador
 de potencia (transistores Darlington).

2000	7F 07		MOV 07	Modo Salidas
	82 83		OUT(07),A	
	62	COMP	LD H,0	
	64		LD L,0	
	4F		XOR A	Porrar acarreo
	7D 42		DEC HI,00	
	7A 11 20		LD H,2011	Dirección negativa?
	28 25		LD Z,0000	Igual?
	03		INC 00	Positiva
	18 01		LD 01	
2011	08		DEC 00	Negativa
	79		LD A,0	Bite menos significativo
	76 07		AND 07	Dos bits
	62		LD H,0	
	64		LD L,0	
	73		EV DE,HI	Guardar cuenta final
	16 00		LD D,0	
	58		LD E,A	
	DD 21 30 20		LD IV,0000	Rotacion de bobinas
	DD 19		ADD IV,DE	Posicion en la tabla
2021	DD 7F 00		LD A,(IV+0)	Codigo de bobinas
	83 81		OUT(81),A	PIO lado P
	82		EV DE,HI	Reponer cuenta en DE
	25 01		LD H,1	Bite más significativo
	2F 00	ESP	LD L,0	Bite menos significativo
	2D		DEC L	de espera
	20 7D		LD HZ ESP	
	25		DEC H	
	20 7A		LD HZ ESP	
2031	18 01		LD COMP	Otro paso
	17	STOP	XOR A	Salidas cero
	07 81		OUT(81),A	
2070	03 48 00		LD DOSTRI	Retorno al monitor
	04 06 05 00 TABLA			

Programa para Salida Audio -- PTO PAO

9

440 Hz (=1a) = 1.13636 msec. por 1/2 ciclo
Frec. del Starter Kit = 1.0069 kHz
2269.1 ciclos = 1.13636 msec.

2260	3F 0F		LDA 0F	Modo de salidas
	D3 92		OUT(92),A	Canal A control
	AF		XOR A	Registro A = 0
	D3 80	REP	OUT(80),A	Canal A datos
	06 9C		LD B,9C	140 veces por el bucle
	05		DEC B	
	20 7D		JR NZ	
	3C		INC A	Cambiar bit 0
	18 76		JR REP	

Cuenta: $16 \cdot 139 + 11 + 11 + 7 + 4 + 12 = 2269$ ciclos.

LOGICA MATEMATICA

(1)

INTRODUCCION:

- DETERMINAR SI UN ARGUMENTO O RAZONAMIENTO ES VALIDO A TRAVES DE REGLAS.
- PARA CUALQUIER RAMA DEL SABER.
- A LAS REGLAS SE LES LLAMA REGLAS DE INFERENCIA.
- SON INDEPENDIENTES DE LA DISCIPLINA.
- EN LA LOGICA NOS INTERESA MAS LA FORMA DE LOS ARGUMENTOS QUE LOS ARGUMENTOS EN SI.
- SE DEBE DECIDIR SOBRE LA VALIDEZ DE UN ARGUMENTO.
- PARA LOGRAR ESTO, LAS REGLAS NO DEBEN SER AMBIGUAS.

(2)

- ES NECESARIO UN LENGUAJE OBJETIVO
- SE USAN SIMBOLOS BIEN DEFINIDOS (LOGICA SIMBOLICA).
- LENGUAJE NATURAL (METALENGUAJE).

PROPOSICIONES Y NOTACION:

- LAS PROPOSICIONES PRIMARIAS SOLO PUEDEN TENER UNO Y SOLO UNO DE LOS "VALORES DE VERDAD" (FALSO/VERDADERO).
- COMO SOLO SE ADMITEN DOS VALORES DE VERDAD (F/V, 1/0, +F/-V...) LA LLAMAREMOS "LOGICA DE DOS VALORES".
- LAS PROPOSICIONES PRIMARIAS SE DENOTAN POR LAS LETRAS MAYUSCULAS (A, B, ... P, Q...)
- LA UNION DE PROPOSICIONES PRIMARIAS A TRAVES DE CONECTIVOS Y MARCAS DE PUNTUACION (COMO PARENTESIS) FORMAN PROPOSICIONES

EJEMPLO PAG. 3.

CONECTIVOS:

- UNA PROPOSICION MOLECULAR ES AQUELLA FORMADA A PARTIR DE PROPOSICIONES

We develop a mechanism by which we can construct in our object language other declarative sentences having one of the two possible truth values. Note that we do not admit any other types of sentence, such as exclamatory, interrogative, etc., in the object language.

Declarative sentences in the object language are of two types. The first type includes those sentences which are considered to be primitive in the object language. These will be denoted by distinct symbols selected from the capital letters $A, B, C, \dots, P, Q, \dots$, while declarative sentences of the second type are obtained from the primitive ones by using certain symbols, called connectives, and certain punctuation marks, such as parentheses, to join primitive sentences. In any case, all the declarative sentences to which it is possible to assign one and only one of the two possible truth values are called *statements*. These statements which do not contain any of the connectives are called *atomic (primary, primitive) statements*.

We shall now give examples of sentences and show why some of them are not admissible in the object language and, hence, will not be symbolized.

1. Canada is a country.
2. Moscow is the capital of Spain.
3. This statement is false.
4. $1 + 101 = 110$.
5. Close the door. → NO IS PROPOSITION
6. Toronto is an old city.
7. Man will reach Mars by 1980.

Obviously Statements (1) and (2) have truth values *true* and *false* respectively. Statement (3) is not a statement according to our definition; because we cannot properly assign to it a definite truth value. If we assign the value *true*, then Sentence (3) says that Statement (3) is false. On the other hand, if we assign it the value *false*, then Sentence (3) implies that Statement (3) is true. This example illustrates a semantic paradox. In (4) we have a statement whose truth value depends upon the context; viz., if we are talking about numbers in the decimal system, then it is a false statement. On the other hand, for numbers in binary, it is a true statement. The truth value of a statement often depends upon its context, which is generally unstated but nonetheless understood. We shall soon see that we are not going to be preoccupied with the actual truth value of a statement. We shall be interested only in the fact that it has a truth value. In this sense (4), (6), and (7) are all statements. Note that Statement (6) is considered true in some parts of the world and false in certain other parts. The truth value of (7) could be determined only in the year 1980, or earlier if a man reaches Mars before that date. But this aspect is not of interest to us. Note that (5) is not a statement; it is a command.

Once we know those atomic statements which are admissible in the object language, we can use symbols to denote them. Methods of constructing and analysing statements constructed from one or more atomic statements are discussed in Sec. 1-2, while the method of symbolising atomic statements will be described here after we discuss some conventions regarding the use and mention of names in statements.

(3)

PRIMARIAS UNIDAS CON CONECTIVOS.

- Ej. P: HOY ESTÁ LLOVIENDO
 Q: MI COCHE ES VERDE
- PODEMOS DETERMINAR LOS VALORES DE VERDAD DE P y Q INDEPENDIENTEMENTE.

+ NEGACION:

- SI "P" ES UNA PROPOSICIÓN, "¬P" ES LA NEGACIÓN DE "P".

TABLA DE VERDAD:

P	¬P
V	F
F	V

- SIMBOLOS ALTERNATIVOS: $\neg P = \bar{P} = \sim P$

+ CONJUNCIÓN:

- LA CONJUNCIÓN DE DOS PROPOSICIONES "P" y "Q" ES LA PROPOSICIÓN "P ∧ Q", QUE SE LEE

P y Q:

TABLA DE VERDAD:

P	Q	P ∧ Q
V	V	V
V	F	F
F	V	F
F	F	F

- SIMBOLOGIA ALTERNATIVA:

$$P \wedge Q = P \text{ AND } Q = P \cdot Q$$

(4)

+ DISYUNCIÓN:

- LA DISYUNCIÓN DE DOS PROPOSICIONES "P" y "Q" ES LA PROPOSICIÓN "P ∨ Q", QUE SE LEE P o Q

TABLA DE VERDAD:

P	Q	P ∨ Q
V	V	V
V	F	V
F	V	V
F	F	F

- SIMBOLOGIA ALTERNATIVA: $P \vee Q = P + Q = P \text{ OR } Q$

FÓRMULAS DE PROPOSICIÓN Y TABLAS DE VERDAD:

EJEMPLOS DE PROPOSICIONES MOLECULARES

- TP (P ∨ Q) ∨ (¬P) PA (¬Q) ¬(¬(P ∨ Q) ∧ (Q ∨ ¬P))
- SE USAN PARENTESIS PARA EVITAR AMBIGÜEDAD.

EJEMPLOS PAGWA 12, 13 y 14.

+ CONDICIONAL:

- $P \rightarrow Q$, se lee "SI P, ENTONCES Q"

TABLA DE VERDAD:

P	Q	P → Q
F	F	T
F	V	T
V	F	F
V	V	T

+ DOBLE CONDICIONAL:

- $P \equiv Q$, se lee "P si y solo si Q"

- $(P \rightarrow Q) \wedge (Q \rightarrow P)$, deducir tabla de verdad.

a statement. This statement has a truth value which depends upon the truth values of the statements used in replacing the variables.

In the construction of formulas, the parentheses will be used in the same sense in which they are used in elementary arithmetic or algebra or sometimes in a computer programming language. This usage means that the expressions in the innermost parentheses are simplified first. With this convention in mind, $\neg(P \wedge Q)$ means the negation of $P \wedge Q$. Similarly $(P \wedge Q) \vee (Q \wedge R)$ means the disjunction of $P \wedge Q$ and $Q \wedge R$. $((P \wedge Q) \vee R) \wedge (\neg P)$ means the conjunction of $\neg P$ and $(P \wedge Q) \vee R$, while $(P \wedge Q) \vee R$ means the disjunction of $P \wedge Q$ and R .

In order to reduce the number of parentheses, we will assume that the negation affects as little as possible of what follows. Thus $\neg P \vee Q$ is written for $(\neg P) \vee Q$, and the negation means the negation of the statement immediately following the symbol \neg . On the other hand, according to our convention, $\neg(P \wedge Q) \vee R$ stands for the disjunction of $\neg(P \wedge Q)$ and R . The negation affects $P \wedge Q$ but not R .

Truth tables have already been introduced in the definitions of the connectives. Our basic concern is to determine the truth value of a statement formula for each possible combination of the truth values of the component statements. A table showing all such truth values is called the truth table of the formula. In Table 1-2.1 we constructed the truth table for $\neg P$. There is only one component or atomic statement, namely P , and so there are only two possible truth values to be considered. Thus Table 1-2.1 has only two rows. In Tables 1-2.2 and 1-2.3 we constructed truth tables for $P \wedge Q$ and $P \vee Q$ respectively. These statement formulas have two component statements, namely P and Q , and there are 2^2 possible combinations of truth values that must be considered. Thus each of the two tables has 2^2 rows. In general, if there are n distinct components in a statement formula, we need to consider 2^n possible combinations of truth values in order to obtain the truth table.

Two methods of constructing truth tables are shown in the following examples.

EXAMPLE 1 Construct the truth table for the statement formula $P \vee \neg Q$.

SOLUTION It is necessary to consider all possible truth values of P and Q . These values are entered in the first two columns of Table 1-2.4 for both methods. In the table which is arrived at by method 1, the truth values of $\neg Q$ are entered

Table 1-2.4a

P	Q	$\neg Q$	$P \vee \neg Q$
T	T	F	T
T	F	T	T
F	T	F	F
F	F	T	T

Method 1

Table 1-2.4b

P	Q	P	\vee	\neg	Q
T	T	T	T	F	T
T	F	T	T	T	F
F	T	F	F	F	T
F	F	F	T	T	F

Step

Number

Method 2

in the third column, and the truth values of $P \vee \neg Q$ are entered in the fourth column. In method 2, as given in Table 1-2.4b, a column is drawn for each statement as well as for the connectives that appear. The truth values are entered step by step. The step numbers at the bottom of the table show the sequence followed in arriving at the final step. //

EXAMPLE 2 Construct the truth table for $P \wedge \neg P$.

SOLUTION See Table 1-2.5. Note that the truth value is F for every possible truth value of P . In this special case, the truth value of $P \wedge \neg P$ is independent of the truth value of P . //

EXAMPLE 3 Construct the truth table for $(P \vee Q) \vee \neg P$.

SOLUTION See Table 1-2.6. In this case the truth value of the formula $(P \vee Q) \vee \neg P$ is independent of the truth values of P and Q . This independence is due to the special construction of the formula, as we shall see in Sec. 1-2.8. //

Table 1-2.5

P	$\neg P$	$P \wedge \neg P$
T	F	F
F	T	F

Method 1

P	$\neg P$	\wedge	\neg	P
T	F	F	F	T
F	T	F	T	F

Step
Number

1 2 2 1

Method 2

Table 1-2.6

P	Q	$P \vee Q$	$\neg P$	$(P \vee Q) \vee \neg P$
T	T	T	F	T
T	F	T	F	T
F	T	T	T	T
F	F	F	T	T

Method 1

P	Q	$(P$	\vee	$Q)$	\vee	\neg	P
T	T	T	T	T	T	F	T
T	F	T	T	F	T	F	T
F	T	F	T	T	T	T	T
F	F	F	F	F	T	T	T

Step

Number

1 2 1 2 2 1

Method 2

Observe that if the truth values of the component statements are known, then the truth value of the resulting statement can be readily determined from the truth table by reading along the row which corresponds to the correct truth values of the component statements.

EXERCISES 1-2.4

1 Using the statements

R : Mark is rich.

H : Mark is happy.

write the following statements in symbolic form:

- (a) Mark is poor but happy.
- (b) Mark is rich or unhappy.
- (c) Mark is neither rich nor happy.
- (d) Mark is poor or he is both rich and unhappy.

2 Construct the truth tables for the following formulas.

- (a) $\neg(\neg P \vee \neg Q)$
- (b) $\neg(\neg P \wedge \neg Q)$
- (c) $P \wedge (P \vee Q)$
- (d) $P \wedge (Q \wedge P)$
- (e) $(\neg P \wedge (\neg Q \wedge R)) \vee (Q \wedge R) \vee (P \wedge R)$
- (f) $(P \wedge Q) \vee (\neg P \wedge Q) \vee (P \wedge \neg Q) \vee (\neg P \wedge \neg Q)$

3 For what truth values will the following statement be true? "It is not the case that houses are cold or haunted and it is false that cottages are warm or houses ugly." (Hint: There are four atomic statements.)

4 Given the truth values of P and Q as T and those of R and S as F , find the truth values of the following:

- (a) $P \vee (Q \wedge R)$
- (b) $(P \wedge (Q \wedge R)) \vee \neg((P \vee Q) \wedge (R \vee S))$
- (c) $(\neg(P \wedge Q) \vee \neg R) \vee (((\neg P \wedge Q) \vee \neg R) \wedge S)$

1-2.5 Logical Capabilities of Programming Languages

In this section we discuss the logical connectives available in certain programming languages and how these connectives can be used to generate a truth table for a statement formula. The logical connectives discussed thus far are available in most programming languages. In PL/I, the connectives \wedge , \vee , and \neg are written as $\&$, $|$, and \neg respectively. The truth values T and F are written as '1'B and '0'B respectively. In ALGOL the connectives are represented as we have written them, while T and F are written as true and false respectively. FORTRAN also permits the use of logical variables and expressions, and it is these facilities which are to be discussed in this section.

In FORTRAN, the truth values T and F are denoted by the logical constants .TRUE. and .FALSE. respectively. Logical variables and expressions in the language assume only one of the logical values at any given time. All logical variables must be explicitly declared as in the statement

LOGICAL P, Q, R

which declares the three variables P , Q , and R .

(5)

EQUIVALENCIA DE FORMULAS:

- 1 $\neg \neg P$ ES EQUIVALENTE A P
- 2 $P \vee P$ ES EQUIVALENTE A P
- 3 $(P \vee \neg P) \wedge Q$ ES EQUIVALENTE A Q
- 4 $(P \vee \neg P)$ ES EQUIVALENTE A $(Q \vee \neg Q)$
- NO ES NECESARIO QUE DOS FORMULAS EQUIVALENTES CONTENGAN LAS MISMAS VARIABLES
- $A \leftrightarrow B$ SE LEE "A ES EQUIVALENTE A B"
- SI $A \leftrightarrow B$ Y $B \leftrightarrow C$ ENTONCES $A \leftrightarrow C$
- LA EQUIVALENCIA SE PRUEBA ATENDIENDO A LOS VALORES DE LA TABLA DE VERDAD

(6)

FORMULAS CON TABLA DE VERDAD DIFERENTES:

CON UNA VARIABLE SE PUEDEN 4 TABLAS DE VERDAD DIFERENTES

P	1	2	3	4
T	T	T	F	F
F	T	F	T	F

CON DOS VARIABLES SE PUEDEN OBTENER 16 TABLAS DE VERDAD DIFERENTES

P	1	2	3	4	5	6	7	8	9	10	11	12	13	14	15	16
T	T	T	T	T	T	T	T	T	T	T	T	T	T	T	T	T
F	T	F	T	F	T	F	T	F	T	F	T	F	T	F	T	F

FORMULAS EQUIVALENTES (COPIA PAG 29)

$\neg \neg P = P$	$P \wedge P = P$	Absorption law	C O L O R E D O
$P \vee \neg P = T$	$P \wedge Q = P \wedge (Q \wedge R)$	Associative law	
$P \vee \neg P = T$	$P \wedge Q = Q \wedge P$	Commutative law	
$P \vee (P \wedge Q) = P$	$P \wedge (P \vee Q) = P$	Distributive law	
$P \vee \neg P = T$	$P \wedge \neg P = F$		
$P \vee \neg P = T$	$P \wedge \neg P = F$		
$P \vee (P \wedge Q) = P$	$P \wedge (P \vee Q) = P$	Absorption law	
$P \vee (P \wedge Q) = P$	$P \wedge (P \vee Q) = P$	De Morgan's law	

EN GENERAL, UNA PROPOSICION QUE CONTIENGA "n" VARIABLES TIENE COMO TABLA DE VERDAD UNA DE LAS 2^n posibles. ESTO SIGUIERE QUE FORMULAS QUE SE VEN EN DIFERENTES TIENEN LA MISMA TABLA DE VERDAD.

CONJUNTOS DE CONECTIVOS COMPLETOS FUNCIONALMENTE

NO TODOS LOS CONECTIVOS DEFINIDOS SON INDISPENSABLES PARA OBTENER LAS DIFERENTES TABLAS DE VERDAD

UN CONJUNTO DE CONECTIVOS FUNCIONALMENTE COMPLETO ES AQUEL QUE NO CONTIENE CONECTIVOS REDUNDANTES, ES DECIR, CONECTIVOS QUE PUEDEN SER EXPRESADOS EN FUNCION DE OTROS CONECTIVOS.

EJEMPLOS DE CONJUNTOS DE CONECTIVOS FUNCIONALMENTE COMPLETO SON: $\{\neg, \vee\}$, $\{\neg, \wedge\}$

OTROS CONECTIVOS

$P \bar{\vee} Q = P \oplus Q = P \text{ XOR } Q$ SE LEE

OR EXCLUSIVO DE P Y Q. TABLA DE VERDAD

P	Q	$P \bar{\vee} Q$
T	T	F
T	F	T
F	T	T
F	F	F

$P \uparrow Q = \neg(P \wedge Q) = P \text{ NAND } Q$ SE LEE

NAND DE P Y Q.

$P \downarrow Q = \neg(P \vee Q) = P \text{ NOR } Q$ SE LEE

NOR DE P Y Q.

$\{\uparrow\}$ y $\{\downarrow\}$ SON FUNCIONALMENTE COMPLETOS

YA QUE

$$\begin{aligned}
 P \uparrow P &\Leftrightarrow \neg(P \wedge P) \Leftrightarrow \neg P \vee \neg P \Leftrightarrow \neg P \\
 (P \uparrow Q) \uparrow (P \uparrow Q) &\Leftrightarrow \neg(P \uparrow Q) \Leftrightarrow P \wedge Q \\
 (P \uparrow P) \uparrow (Q \uparrow Q) &\Leftrightarrow \neg P \uparrow \neg Q \Leftrightarrow P \vee Q
 \end{aligned}$$

SIKILARMENTE SE PUEDE DEMOSTRAR CON \downarrow , POR LO QUE $\{\uparrow\}$ y $\{\downarrow\}$ SON LOS CONJUNTOS FUNCIONALMENTE COMPLETOS MÍNIMOS.

CONJUNTO DE IDENTIDADES BÁSICAS Y SU RELACION CON LA TEORIA DE CONJUNTOS.

COPIA PAG 119.

Algebra	Equivalent Algebra	
	Idempotent law	
$A \vee A = A$	$P \vee P = P$	✓
$A \wedge A = A$	$P \wedge P = P$	✓
	Associative law	
$(A \vee B) \vee C = A \vee (B \vee C)$	$P \vee (Q \vee R) = (P \vee Q) \vee R$	✓
$(A \wedge B) \wedge C = A \wedge (B \wedge C)$	$P \wedge (Q \wedge R) = (P \wedge Q) \wedge R$	✓
	Distributive law	
$A \vee (B \wedge C) = (A \vee B) \wedge (A \vee C)$	$P \vee (Q \wedge R) = (P \vee Q) \wedge (P \vee R)$	✓
$A \wedge (B \vee C) = (A \wedge B) \vee (A \wedge C)$	$P \wedge (Q \vee R) = (P \wedge Q) \vee (P \wedge R)$	✓
	De Morgan's law	
$\neg(A \vee B) = \neg A \wedge \neg B$	$\neg(P \vee Q) = \neg P \wedge \neg Q$	✓
$\neg(A \wedge B) = \neg A \vee \neg B$	$\neg(P \wedge Q) = \neg P \vee \neg Q$	✓
	Double negation law	
$\neg(\neg A) = A$	$\neg(\neg P) = P$	✓
	Identity law	
$A \vee 0 = A$	$P \vee 0 = P$	✓
$A \wedge 1 = A$	$P \wedge 1 = P$	✓
	Complement law	
$A \vee \neg A = 1$	$P \vee \neg P = 1$	✓
$A \wedge \neg A = 0$	$P \wedge \neg P = 0$	✓
	Domination law	
$A \vee 1 = 1$	$P \vee 1 = 1$	✓
$A \wedge 0 = 0$	$P \wedge 0 = 0$	✓

POSTULADOS Y TEOREMAS DEL ALGEBRA DE BOOLE

Postulado 1	(a) $x + 0 = x$	(b) $x \cdot 1 = x$
Postulado 2	(a) $x + x' = 1$	(b) $x \cdot x' = 0$
Teorema 1	(a) $x + x = x$	(b) $x \cdot x = x$
Teorema 2	(a) $x + 1 = 1$	(b) $x \cdot 0 = 0$
Teorema 3, involucion	$(x')' = x$	
Postulado 3, asociatividad	(a) $x + (y + z) = (x + y) + z$	(b) $x \cdot (y \cdot z) = (x \cdot y) \cdot z$
Teorema 4, distributiva	(a) $x + (y \cdot z) = (x + y) \cdot (x + z)$	(b) $x \cdot (y + z) = (x \cdot y) + (x \cdot z)$
Postulado 4, absorcion	(a) $x \cdot (x + y) = x$	(b) $x + (x \cdot y) = x$
Teorema 5, De Morgan	(a) $(x + y)' = x' \cdot y'$	(b) $(x \cdot y)' = x' + y'$
Teorema 6, absorcion	(a) $x + x \cdot y = x$	(b) $x \cdot x + y = x + y$

TEOREMA 6 (a): $x + xy = x$

$$\begin{aligned}
 x + xy &= x \cdot 1 + xy \\
 &= x(1 + y) \\
 &= x(1) = x
 \end{aligned}$$

PRECEDENCIA DE OPERADORES:

- 1° PARENTESIS
- 2° NOT
- 3° AND
- 4° OR

FUNCIONES BOOLEANAS

$$F_1 = xyz'$$

F_1 ES IGUAL A $x=1$ y $y=1$ y $z'=1$, DE OTRA MANERA $F_1=0$.

Ej. SIMPLIFICAR LA SIGUIENTE FUNCION BOOLEANA AL MINIMO NUMERO DE LITERALES

1. $x'y'z + x'yz + xy' =$
 $x'z(y+y') + xy' = x'z + xy'$
2. $xy + x'z + yz =$
 $xy + x'z + xyz + x'yz =$
 $xy(1+z) + x'z(1+y) = xy + x'z$

Ej. COMPLEMENTAR LA FUNCION

$$\begin{aligned}
 1. F_1 &= x'y'z' + x'y'z \quad ; \quad F_1' = ? \\
 F_1' &= (x'y'z' + x'y'z)' = \\
 &= (x'y'z')' \cdot (x'y'z)' = \\
 &= (x+y+z)(x+y+z')
 \end{aligned}$$

MINITERMS Y MAXITERMS

- SI TENEMOS n VARIABLES, TENEMOS 2^n DIFERENTES PRODUCTOS STANDARD, A CADA UNO DE ELLOS SE LE LLAMA MINITERM.
- EL SÍMBOLO PARA CADA MINITERMINO ES m_i DONDE i ES EL EQUIVALENTE DECIMAL DEL NUMERO BINARIO DEL MINITERM.

Ej. $x'y'z'$
 $(0101) \dots m_4$

- CADA MAXTERMINO ES EL COMPLEMENTO DEL CORRESPONDIENTE MINTERMINO.

Ej: $f(x, y, z) = m_3$
 $m_3 = xyz$; $M_3 = x' + y' + z'$
 $(xyz)' = (x' + y' + z')$

- TODA FUNCION BOOLEANA PUEDE SER EXPRESADA COMO SUMA DE MINTERMINOS

Ej
 $f(x, y, z) = xyz + xy'z + xy'z' + x'yz = m_3 + m_2 + m_4 + m_5$

EXPRESAR LA FUNCION $F = A + B'C$ EN SUMA DE MINTERMINOS

$A = ABC + ABC' + AB'C + AB'C'$
 $B'C = AB'C + A'B'C$
 $A + B'C = ABC + ABC' + AB'C + AB'C' + A'B'C$
 $= m_3 + m_2 + m_4 + m_5 + m_1$

$F(A, B, C) = \Sigma(1, 2, 4, 5, 7)$
 NOTACION CORTA.

REPRESENTACION DE LAS FUNCIONES DE BOOLE CON LOS MAPAS DE KARNAUGH.

- APROVECHA LA CAPACIDAD HUMANA DE PERCIBIR PATRONES EN REPRESENTACIONES PICTORICAS DE DATOS.

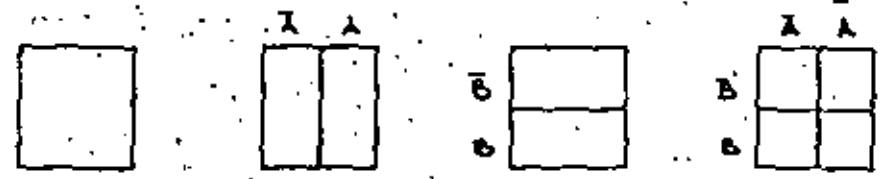

CONJUNTO UNIVERSAL

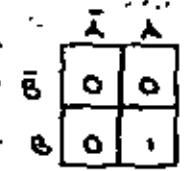

$\bar{A}\bar{B} = 0$
 $\bar{A}B = 0$
 $A\bar{B} = 0$
 $AB = 1$

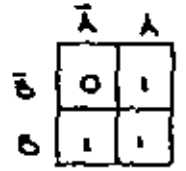

$\bar{A}\bar{B} = 0$
 $\bar{A}B = 1$
 $A\bar{B} = 1$
 $AB = 1$

MAPAS DE KARNAUGH PARA 3 VARIABLES.

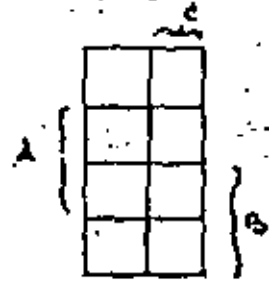
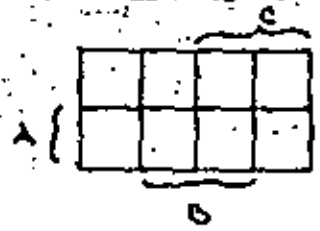

Ej. ELABORAR EL MAPA K DE:

f(A, B, C) = A \bar{B} + \bar{C}

		B	
	A	0	1
A	0	1	0
	1	1	1
		C	

Two variables

	B
A=0	1
A=1	1

Three variables

	BC			
	00	01	11	10
A=0	0	1	0	1
A=1	1	1	1	1

Four variables

	BC			
	00	01	11	10
A=0	0	1	0	1
A=1	1	1	1	1

Four variables

	BC			
	00	01	11	10
A=0	0	1	0	1
A=1	1	1	1	1

Five variables

	BC			
	00	01	11	10
A=0	0	1	0	1
A=1	1	1	1	1

SIMPLIFICACION DE LAS FUNCIONES EN LOS MAPAS.

- SE CONSIDERARA LA EXPRESION MINIMA SI:
 - 1) NO EXISTE OTRA EXPRESION EQUIVALENTE QUE INCLUYA MENOS PRODUCTOS
 - 2) NO HAY OTRA EXPRESION EQUIVALENTE QUE CONSTE DEL MISMO NUMERO DE PRODUCTOS PERO CON UN MENOR NUMERO DE LITERALES.

Ej. $f(A, B, C) = \sum m(0, 1, 4, 6)$
 $= \bar{A}\bar{B}\bar{C} + \bar{A}\bar{B}C + A\bar{B}\bar{C} + A\bar{B}C$

CON MANIPULACION ALGEBRAICA
 $= \bar{A}\bar{B}(\bar{C} + C) + A\bar{B}(\bar{C} + C)$
 $= \bar{A}\bar{B} + A\bar{B}$

VEAMOS EL MAPA K

	BC			
	00	01	11	10
A=0	1		1	
A=1	1			

SI A=0 y B=0 ENTONCES f=1 ($\bar{A}\bar{B}$)
 SI A=1 y C=0 ENTONCES f=1 ($A\bar{C}$)

142 Minimización de las funciones de Boole

Ejemplo 6.9

Simplificar $f(A, B, C, D) = \sum m(0, 1, 2, 3, 13, 15)$.

Solución



Figura 6.29.

El ejemplo 6.9 no presentó ninguna dificultad, ya que sólo fue posible un conjunto de adyacencias.

Ejemplo 6.10

Simplificar $f(A, B, C, D) = \sum m(0, 2, 10, 11, 12, 13)$.

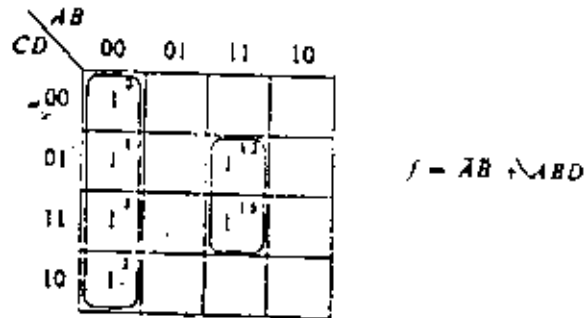
Solución:



Figura 6.30.

En este caso, se tienen más posibilidades. También se podría haber combinado m_2 y m_{10} , o m_{10} y m_{14} . No obstante, no hay ninguna razón para utilizar estas combinaciones, dado que m_2 , m_{10} , y m_{14} ya están cubiertas (o contenidas) por la formación necesaria de pares con m_0 , m_{12} , m_{13} , respectivamente, para las cuales no existe otra posibilidad. Por lo tanto, una regla para utilizar los mapas de Karnaugh es principiar con la combinación de los términos para los cuales existe una sola posibilidad.

Ejemplo 6.11

Simplificar $f(A, B, C, D) = \sum m(0, 2, 8, 12, 13)$.

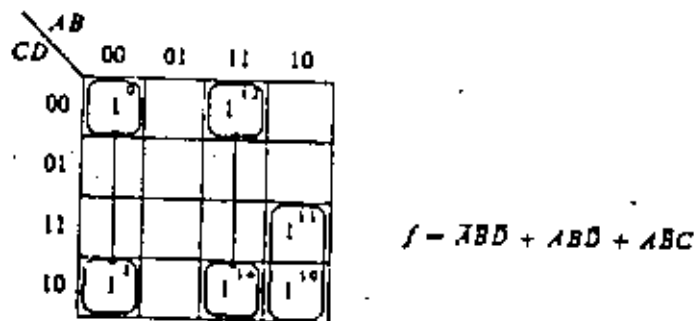
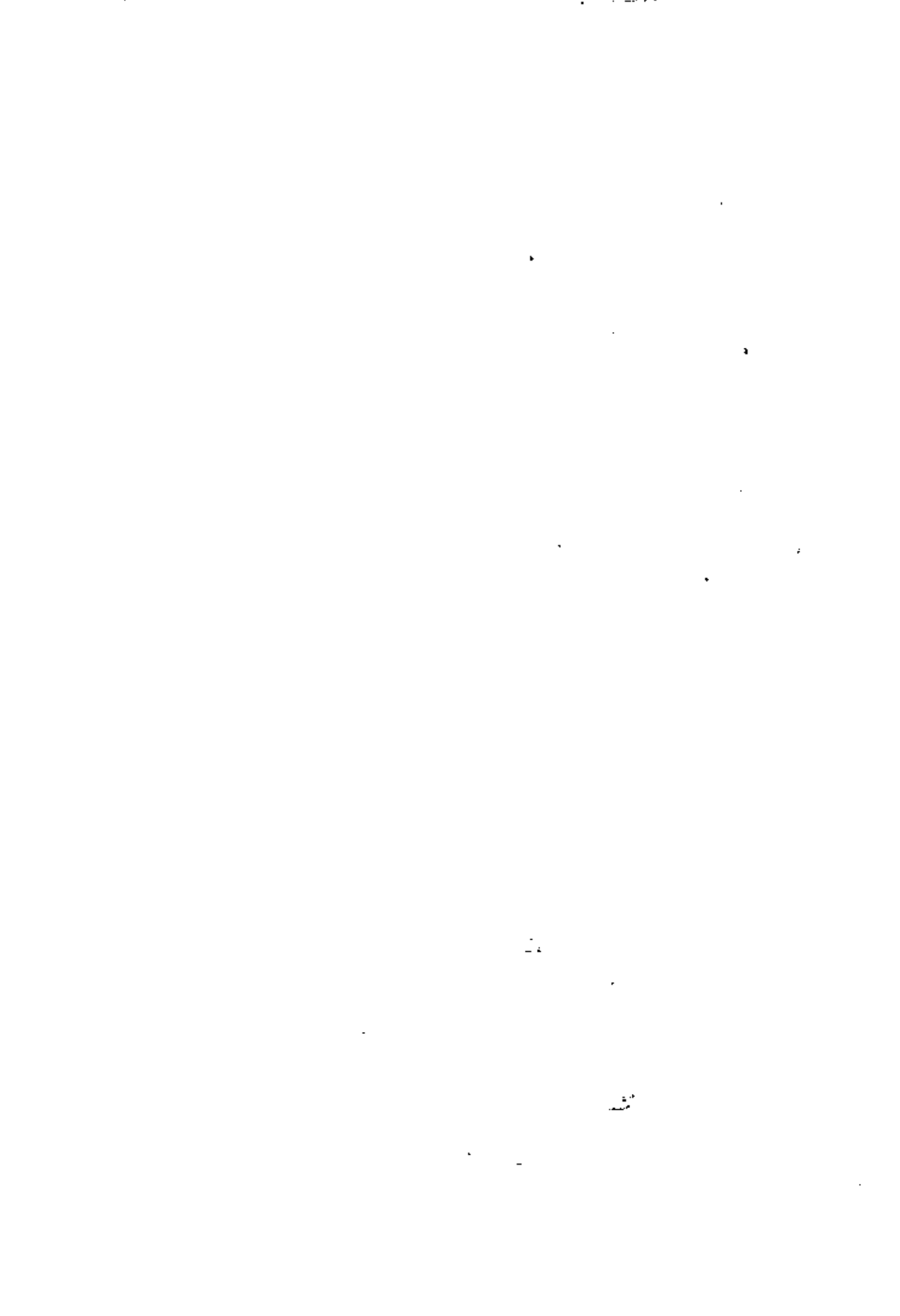

Simplificación de las funciones en los mapas de Karnaugh 146

Solución:



Figura 6.34.

Ejemplo 6.15

$$f(A, B, C, D) = \prod M(7, 9, 13)$$

Solución:

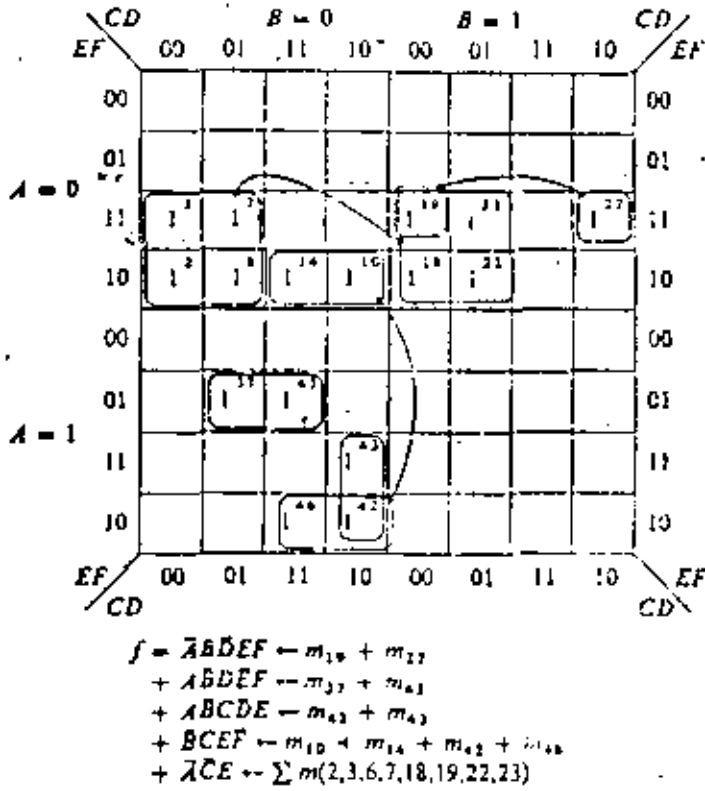

Figura 6.35.

1. 10

2. 10

3. 10

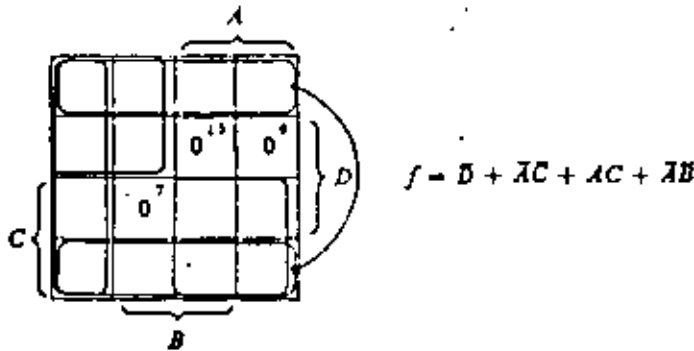
4. 10

5. 10

6. 10

7. 10

8. 10

9. 10

146 Minimización de las funciones de Boole

Ejemplo 6.16

$$f(A, B, C, D) = \sum m(0, 1, 2, 4, 5, 8, 10)$$

Solución:



Figura 6.36.

Ejemplo 6.17

$$f(A, B, C, D, E) = \sum m(0, 1, 3, 4, 5, 7, 8, 9, 10, 12, 13, 21, 24, 25, 26, 28, 29)$$

Solución:

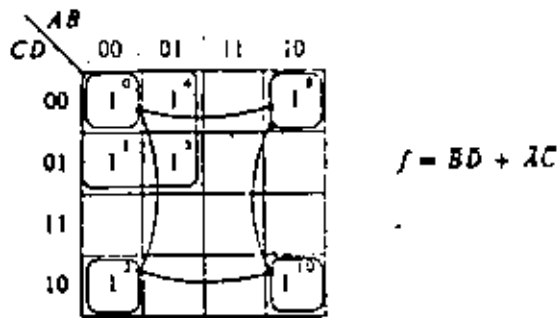
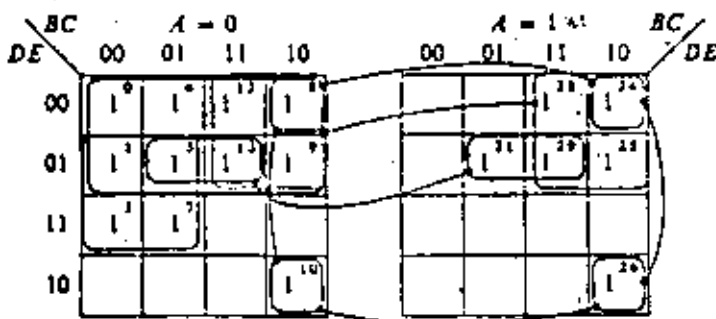

$$\begin{aligned} f &= CDE - \sum m(5, 13, 21, 29) \\ &+ \bar{A}BE - \sum m(1, 3, 5, 7) \\ &+ \bar{A}D - \sum m(0, 1, 4, 5, 8, 9, 12, 13) \\ &+ BCE - \sum m(8, 10, 24, 26) \\ &+ BD - \sum m(8, 9, 12, 13, 24, 25, 28, 29) \end{aligned}$$

Figura 6.37.

SYSTEMS ORGANIZATION

THE SYSTEMS ORGANIZATION
DATE: 10/10/2023

1. Introduction

The systems organization is a complex structure that involves the integration of various components to achieve a common goal. This document outlines the key elements and processes of such an organization.

The primary objective of the systems organization is to ensure that all components are effectively coordinated and managed. This involves a clear understanding of the system's architecture and the roles of its various parts. The organization must also be flexible enough to adapt to changing requirements and technologies.

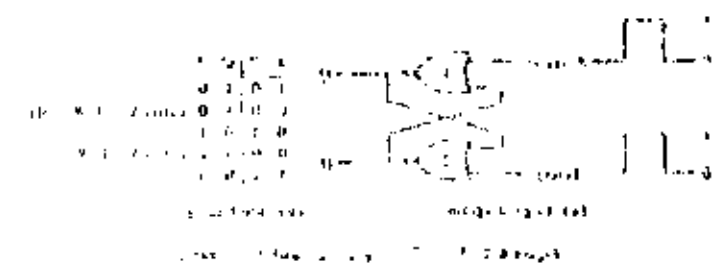
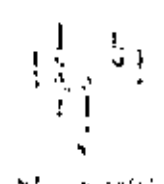
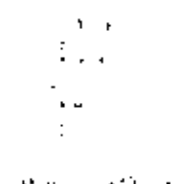
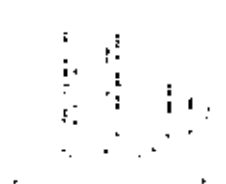
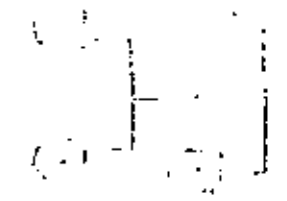
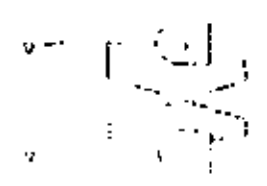
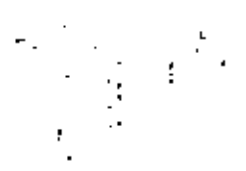

CIRCUITOS SECUENCIALES

SISTEMA COMBINACIONAL:

+ EL VALOR ACTUAL DE LAS SALIDAS ESTA DETERMINADO EXCLUSIVAMENTE POR EL VALOR ACTUAL DE LAS ENTRADAS.

+ LOS VALORES DE TODAS LAS VARIABLES SERAN ESOS EN ALGUN INSTANTE UNICO.

SISTEMA SECUENCIAL:

+ EL VALOR ACTUAL DE LAS SALIDAS DEPENDE NO SOLO DEL VALOR ACTUAL DE LAS ENTRADAS, SINO TAMBIEN DE LA HISTORIA DEL SISTEMA.

+ ALMACENA INFORMACION RESPECTO A EVENTOS PREVIOS.

+ LOS HAY SINCRONOS Y ASINCRONOS.

FLIP-FLOP'S

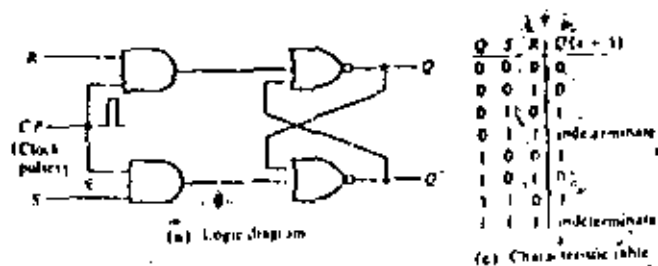

(a) Logic diagram

(c) Characteristic table

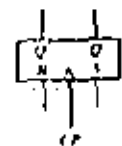

(b) Graphic symbol

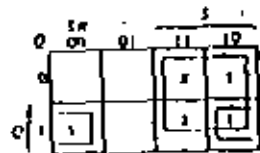

$$Q_{11} = 1, S = R = 0$$

$$SR = 0$$

(d) Characteristic equation

Figure 6-4 Clocked RS flip-flop

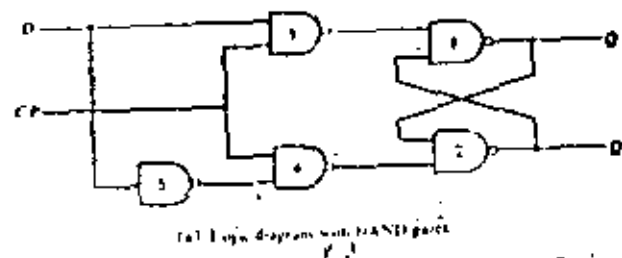

(a) Logic diagram with NAND gates

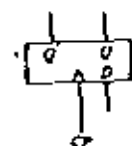

(b) Graphic symbol

Q	D	Q(n+1)
0	0	0
0	1	1
1	0	0
1	1	1

(c) Characteristic table

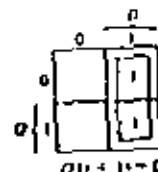

$$Q_{11} = 1, D = Q$$

(d) Characteristic equation

Figure 6-5 Clocked D flip-flop

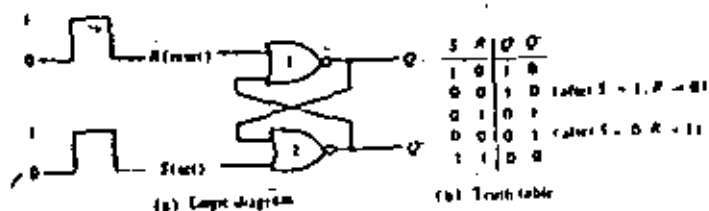

(a) Logic diagram

(b) Truth table

Figure 6-2 Basic flip-flop circuit with NAND gates

CONFERENCE ON THE
 STATE OF THE
 ECONOMY

CONFERENCE ON THE
 STATE OF THE
 ECONOMY

CONFERENCE ON THE
 STATE OF THE
 ECONOMY

CONFERENCE ON THE
 STATE OF THE
 ECONOMY

CONFERENCE ON THE
 STATE OF THE
 ECONOMY

CONFERENCE ON THE
 STATE OF THE
 ECONOMY

CONFERENCE ON THE
 STATE OF THE
 ECONOMY

CONFERENCE ON THE
 STATE OF THE
 ECONOMY

CONFERENCE ON THE
 STATE OF THE
 ECONOMY

CONFERENCE ON THE
 STATE OF THE
 ECONOMY

Year	1960	1961	1962	1963	1964
GDP	100	100	100	100	100
Unemployment	7.0	6.7	6.5	6.3	6.1
Inflation	1.1	1.6	2.1	2.6	3.1
Interest Rate	4.0	4.0	4.0	4.0	4.0



PROCEDIMIENTO DE DISEÑO

Table 6-9 State table

Present state		Next state			
		x = 0		x = 1	
A	B	A	B	A	B
0	0	0	0	0	1
0	1	1	0	0	1
1	0	1	0	1	1
1	1	1	1	0	0

Table 6-10 Excitation table

Inputs of combinational circuit			Outputs of combinational circuit						
Present state		Input x	Next state		Flip-flop inputs				
A	B		A	B	JA	KA	JB	KB	
0	0	0	0	0	0	X	0	X	X
0	0	1	0	1	0	X	1	X	X
0	1	0	1	0	1	X	X	X	1
0	1	1	1	0	0	X	X	X	0
1	0	0	1	0	X	0	0	X	X
1	0	1	1	0	X	0	X	X	0
1	1	0	1	1	X	1	X	X	1
1	1	1	0	0	X	1	X	X	1

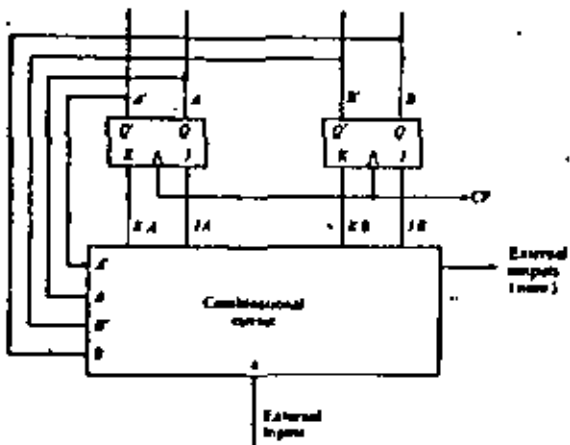

Figure 6-22 Block diagram of sequential circuit

DISEÑO DE CONTADORES

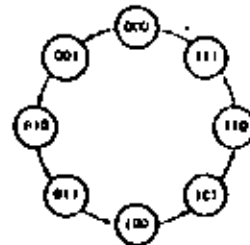

Figure 6-23 State diagram of a 3-bit binary counter

Table 6-11 Excitation table for a 3-bit binary counter

Count sequence			Flip-flop inputs		
A ₂	A ₁	A ₀	TA ₂	TA ₁	TA ₀
0	0	0	0	0	1
0	0	1	0	1	1
0	1	0	0	0	1
0	1	1	1	1	1
1	0	0	0	0	1
1	0	1	0	0	1
1	1	0	0	0	1
1	1	1	1	1	1

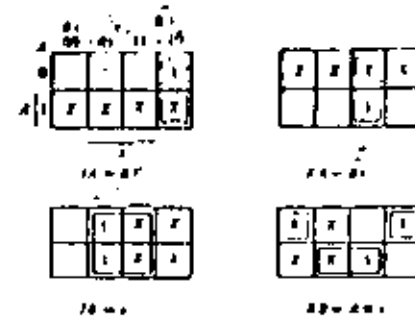

Figure 6-21 Maps for combinational circuit

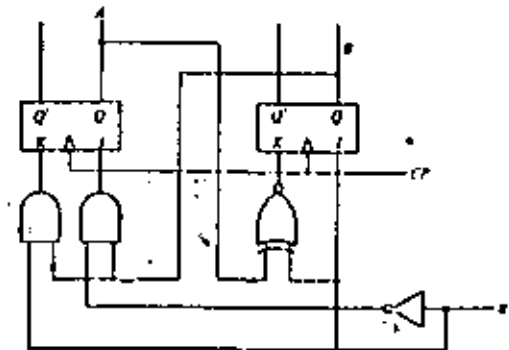

Figure 6-20 Logic diagram of sequential circuit

1. 1940
 2. 1941
 3. 1942
 4. 1943
 5. 1944
 6. 1945
 7. 1946
 8. 1947
 9. 1948
 10. 1949
 11. 1950
 12. 1951
 13. 1952
 14. 1953
 15. 1954
 16. 1955
 17. 1956
 18. 1957
 19. 1958
 20. 1959
 21. 1960
 22. 1961
 23. 1962
 24. 1963
 25. 1964
 26. 1965
 27. 1966
 28. 1967
 29. 1968
 30. 1969
 31. 1970
 32. 1971
 33. 1972
 34. 1973
 35. 1974
 36. 1975
 37. 1976
 38. 1977
 39. 1978
 40. 1979
 41. 1980
 42. 1981
 43. 1982
 44. 1983
 45. 1984
 46. 1985
 47. 1986
 48. 1987
 49. 1988
 50. 1989
 51. 1990
 52. 1991
 53. 1992
 54. 1993
 55. 1994
 56. 1995
 57. 1996
 58. 1997
 59. 1998
 60. 1999
 61. 2000
 62. 2001
 63. 2002
 64. 2003
 65. 2004
 66. 2005
 67. 2006
 68. 2007
 69. 2008
 70. 2009
 71. 2010
 72. 2011
 73. 2012
 74. 2013
 75. 2014
 76. 2015
 77. 2016
 78. 2017
 79. 2018
 80. 2019
 81. 2020
 82. 2021
 83. 2022
 84. 2023
 85. 2024
 86. 2025
 87. 2026
 88. 2027
 89. 2028
 90. 2029
 91. 2030
 92. 2031
 93. 2032
 94. 2033
 95. 2034
 96. 2035
 97. 2036
 98. 2037
 99. 2038
 100. 2039
 101. 2040
 102. 2041
 103. 2042
 104. 2043
 105. 2044
 106. 2045
 107. 2046
 108. 2047
 109. 2048
 110. 2049
 111. 2050
 112. 2051
 113. 2052
 114. 2053
 115. 2054
 116. 2055
 117. 2056
 118. 2057
 119. 2058
 120. 2059
 121. 2060
 122. 2061
 123. 2062
 124. 2063
 125. 2064
 126. 2065
 127. 2066
 128. 2067
 129. 2068
 130. 2069
 131. 2070
 132. 2071
 133. 2072
 134. 2073
 135. 2074
 136. 2075
 137. 2076
 138. 2077
 139. 2078
 140. 2079
 141. 2080
 142. 2081
 143. 2082
 144. 2083
 145. 2084
 146. 2085
 147. 2086
 148. 2087
 149. 2088
 150. 2089
 151. 2090
 152. 2091
 153. 2092
 154. 2093
 155. 2094
 156. 2095
 157. 2096
 158. 2097
 159. 2098
 160. 2099
 161. 2100
 162. 2101
 163. 2102
 164. 2103
 165. 2104
 166. 2105
 167. 2106
 168. 2107
 169. 2108
 170. 2109
 171. 2110
 172. 2111
 173. 2112
 174. 2113
 175. 2114
 176. 2115
 177. 2116
 178. 2117
 179. 2118
 180. 2119
 181. 2120
 182. 2121
 183. 2122
 184. 2123
 185. 2124
 186. 2125
 187. 2126
 188. 2127
 189. 2128
 190. 2129
 191. 2130
 192. 2131
 193. 2132
 194. 2133
 195. 2134
 196. 2135
 197. 2136
 198. 2137
 199. 2138
 200. 2139
 201. 2140
 202. 2141
 203. 2142
 204. 2143
 205. 2144
 206. 2145
 207. 2146
 208. 2147
 209. 2148
 210. 2149
 211. 2150
 212. 2151
 213. 2152
 214. 2153
 215. 2154
 216. 2155
 217. 2156
 218. 2157
 219. 2158
 220. 2159
 221. 2160
 222. 2161
 223. 2162
 224. 2163
 225. 2164
 226. 2165
 227. 2166
 228. 2167
 229. 2168
 230. 2169
 231. 2170
 232. 2171
 233. 2172
 234. 2173
 235. 2174
 236. 2175
 237. 2176
 238. 2177
 239. 2178
 240. 2179
 241. 2180
 242. 2181
 243. 2182
 244. 2183
 245. 2184
 246. 2185
 247. 2186
 248. 2187
 249. 2188
 250. 2189
 251. 2190
 252. 2191
 253. 2192
 254. 2193
 255. 2194
 256. 2195
 257. 2196
 258. 2197
 259. 2198
 260. 2199
 261. 2200
 262. 2201
 263. 2202
 264. 2203
 265. 2204
 266. 2205
 267. 2206
 268. 2207
 269. 2208
 270. 2209
 271. 2210
 272. 2211
 273. 2212
 274. 2213
 275. 2214
 276. 2215
 277. 2216
 278. 2217
 279. 2218
 280. 2219
 281. 2220
 282. 2221
 283. 2222
 284. 2223
 285. 2224
 286. 2225
 287. 2226
 288. 2227
 289. 2228
 290. 2229
 291. 2230
 292. 2231
 293. 2232
 294. 2233
 295. 2234
 296. 2235
 297. 2236
 298. 2237
 299. 2238
 300. 2239
 301. 2240
 302. 2241
 303. 2242
 304. 2243
 305. 2244
 306. 2245
 307. 2246
 308. 2247
 309. 2248
 310. 2249
 311. 2250
 312. 2251
 313. 2252
 314. 2253
 315. 2254
 316. 2255
 317. 2256
 318. 2257
 319. 2258
 320. 2259
 321. 2260
 322. 2261
 323. 2262
 324. 2263
 325. 2264
 326. 2265
 327. 2266
 328. 2267
 329. 2268
 330. 2269
 331. 2270
 332. 2271
 333. 2272
 334. 2273
 335. 2274
 336. 2275
 337. 2276
 338. 2277
 339. 2278
 340. 2279
 341. 2280
 342. 2281
 343. 2282
 344. 2283
 345. 2284
 346. 2285
 347. 2286
 348. 2287
 349. 2288
 350. 2289
 351. 2290
 352. 2291
 353. 2292
 354. 2293
 355. 2294
 356. 2295
 357. 2296
 358. 2297
 359. 2298
 360. 2299
 361. 2300
 362. 2301
 363. 2302
 364. 2303
 365. 2304
 366. 2305
 367. 2306
 368. 2307
 369. 2308
 370. 2309
 371. 2310
 372. 2311
 373. 2312
 374. 2313
 375. 2314
 376. 2315
 377. 2316
 378. 2317
 379. 2318
 380. 2319
 381. 2320
 382. 2321
 383. 2322
 384. 2323
 385. 2324
 386. 2325
 387. 2326
 388. 2327
 389. 2328
 390. 2329
 391. 2330
 392. 2331
 393. 2332
 394. 2333
 395. 2334
 396. 2335
 397. 2336
 398. 2337
 399. 2338
 400. 2339
 401. 2340
 402. 2341
 403. 2342
 404. 2343
 405. 2344
 406. 2345
 407. 2346
 408. 2347
 409. 2348
 410. 2349
 411. 2350
 412. 2351
 413. 2352
 414. 2353
 415. 2354
 416. 2355
 417. 2356
 418. 2357
 419. 2358
 420. 2359
 421. 2360
 422. 2361
 423. 2362
 424. 2363
 425. 2364
 426. 2365
 427. 2366
 428. 2367
 429. 2368
 430. 2369
 431. 2370
 432. 2371
 433. 2372
 434. 2373
 435. 2374
 436. 2375
 437. 2376
 438. 2377
 439. 2378
 440. 2379
 441. 2380
 442. 2381
 443. 2382
 444. 2383
 445. 2384
 446. 2385
 447. 2386
 448. 2387
 449. 2388
 450. 2389
 451. 2390
 452. 2391
 453. 2392
 454. 2393
 455. 2394
 456. 2395
 457. 2396
 458. 2397
 459. 2398
 460. 2399
 461. 2400
 462. 2401
 463. 2402
 464. 2403
 465. 2404
 466. 2405
 467. 2406
 468. 2407
 469. 2408
 470. 2409
 471. 2410
 472. 2411
 473. 2412
 474. 2413
 475. 2414
 476. 2415
 477. 2416
 478. 2417
 479. 2418
 480. 2419
 481. 2420
 482. 2421
 483. 2422
 484. 2423
 485. 2424
 486. 2425
 487. 2426
 488. 2427
 489. 2428
 490. 2429
 491. 2430
 492. 2431
 493. 2432
 494. 2433
 495. 2434
 496. 2435
 497. 2436
 498. 2437
 499. 2438
 500. 2439
 501. 2440
 502. 2441
 503. 2442
 504. 2443
 505. 2444
 506. 2445
 507. 2446
 508. 2447
 509. 2448
 510. 2449
 511. 2450
 512. 2451
 513. 2452
 514. 2453
 515. 2454
 516. 2455
 517. 2456
 518. 2457
 519. 2458
 520. 2459
 521. 2460
 522. 2461
 523. 2462
 524. 2463
 525. 2464
 526. 2465
 527. 2466
 528. 2467
 529. 2468
 530. 2469
 531. 2470
 532. 2471
 533. 2472
 534. 2473
 535. 2474
 536. 2475
 537. 2476
 538. 2477
 539. 2478
 540. 2479
 541. 2480
 542. 2481
 543. 2482
 544. 2483
 545. 2484
 546. 2485
 547. 2486
 548. 2487
 549. 2488
 550. 2489
 551. 2490
 552. 2491
 553. 2492
 554. 2493
 555. 2494
 556. 2495
 557. 2496
 558. 2497
 559. 2498
 560. 2499
 561. 2500
 562. 2501
 563. 2502
 564. 2503
 565. 2504
 566. 2505
 567. 2506
 568. 2507
 569. 2508
 570. 2509
 571. 2510
 572. 2511
 573. 2512
 574. 2513
 575. 2514
 576. 2515
 577. 2516
 578. 2517
 579. 2518
 580. 2519
 581. 2520
 582. 2521
 583. 2522
 584. 2523
 585. 2524
 586. 2525
 587. 2526
 588. 2527
 589. 2528
 590. 2529
 591. 2530
 592. 2531
 593. 2532
 594. 2533
 595. 2534
 596. 2535
 597. 2536
 598. 2537
 599. 2538
 600. 2539
 601. 2540
 602. 2541
 603. 2542
 604. 2543
 605. 2544
 606. 2545
 607. 2546
 608. 2547
 609. 2548
 610. 2549
 611. 2550
 612. 2551
 613. 2552
 614. 2553
 615. 2554
 616. 2555
 617. 2556
 618. 2557
 619. 2558
 620. 2559
 621. 2560
 622. 2561
 623. 2562
 624. 2563
 625. 2564
 626. 2565
 627. 2566
 628. 2567
 629. 2568
 630. 2569
 631. 2570
 632. 2571
 633. 2572
 634. 2573
 635. 2574
 636. 2575
 637. 2576
 638. 2577
 639. 2578
 640. 2579
 641. 2580
 642. 2581
 643. 2582
 644. 2583
 645. 2584
 646. 2585
 647. 2586
 648. 2587
 649. 2588
 650. 2589
 651. 2590
 652. 2591
 653. 2592
 654. 2593
 655. 2594
 656. 2595
 657. 2596
 658. 2597
 659. 2598
 660. 2599
 661. 2600
 662. 2601
 663. 2602
 664. 2603
 665. 2604
 666. 2605
 667. 2606
 668. 2607
 669. 2608
 670. 2609
 671. 2610
 672. 2611
 673. 2612
 674. 2613
 675. 2614
 676. 2615
 677. 2616
 678. 2617
 679. 2618
 680. 2619
 681. 2620
 682. 2621
 683. 2622
 684. 2623
 685. 2624
 686. 2625
 687. 2626
 688. 2627
 689. 2628
 690. 2629
 691. 2630
 692. 2631
 693. 2632
 694. 2633
 695. 2634
 696. 2635
 697. 2636
 698. 2637
 699. 2638
 700. 2639
 701. 2640
 702. 2641
 703. 2642
 704. 2643
 705. 2644
 706. 2645
 707. 2646
 708. 2647
 709. 2648
 710. 2649
 711. 2650
 712. 2651
 713. 2652
 714. 2653
 715. 2654
 716. 2655
 717. 2656
 718. 2657
 719. 2658
 720. 2659
 721. 2660
 722. 2661
 723. 2662
 724. 2663
 725. 2664
 726. 2665
 727. 2666
 728. 2667
 729. 2668
 730. 2669
 731. 2670
 732. 2671
 733. 2672
 734. 2673
 735. 2674
 736. 2675
 737. 2676
 738. 2677
 739. 2678
 740. 2679
 741. 2680
 742. 2681
 743. 2682
 744. 2683
 745. 2684
 746. 2685
 747. 2686
 748. 2687
 749. 2688
 750. 2689
 751. 2690
 752. 2691
 753. 2692
 754. 2693
 755. 2694
 756. 2695
 757. 2696
 758. 2697
 759. 2698
 760. 2699
 761. 2700
 762. 2701
 763. 2702
 764. 2703
 765. 2704
 766. 2705
 767. 2706
 768. 2707
 769. 2708
 770. 2709
 771. 2710
 772. 2711
 773. 2712
 774. 2713
 775. 2714
 776. 2715
 777. 2716
 778. 2717
 779. 2718
 780. 2719
 781. 2720
 782. 2721
 783. 2722
 784. 2723
 785. 2724
 786. 2725
 787. 2726
 788. 2727
 789. 2728
 790. 2729
 791. 2730
 792. 2731
 793. 2732
 794. 2733
 795. 2734
 796. 2735
 797. 2736
 798. 2737
 799. 2738
 800. 2739
 801. 2740
 802. 2741
 803. 2742
 804. 2743
 805. 2744
 806. 2745
 807. 2746
 808. 2747
 809. 2748
 810. 2749
 811. 2750
 812. 2751
 813. 2752
 814. 2753
 815. 2754
 816. 2755
 817. 2756
 818. 2757
 819. 2758
 820. 2759
 821. 2760
 822. 2761
 823. 2762
 824. 2763
 825. 2764
 826. 2765
 827. 2766
 828. 2767
 829. 2768
 830. 2769
 831. 2770
 832. 2771
 833. 2772
 834. 2773
 835. 2774
 836. 2775
 837. 2776
 838. 2777
 839. 2778
 840. 2779
 841. 2780
 842. 2781
 843. 2782
 844. 2783
 845. 2784
 846. 2785
 847. 2786
 848. 2787
 849. 2788
 850. 2789
 851. 2790
 852. 2791
 853. 2792
 854. 2793
 855. 2794
 856. 2795
 857. 2796
 858. 2797
 859. 2798
 860. 2799
 861. 2800
 862. 2801
 863. 2802
 864. 2803
 865. 2804
 866. 2805
 867. 2806
 868. 2807
 869. 2808
 870. 2809
 871. 2810
 872. 2811
 873. 2812
 874. 2813
 875. 2814
 876. 2815
 877. 2816
 878. 2817
 879. 2818
 880. 2819
 881. 2820
 882. 2821
 883. 2822
 884. 2823
 885. 2824
 886. 2825
 887. 2826
 888.

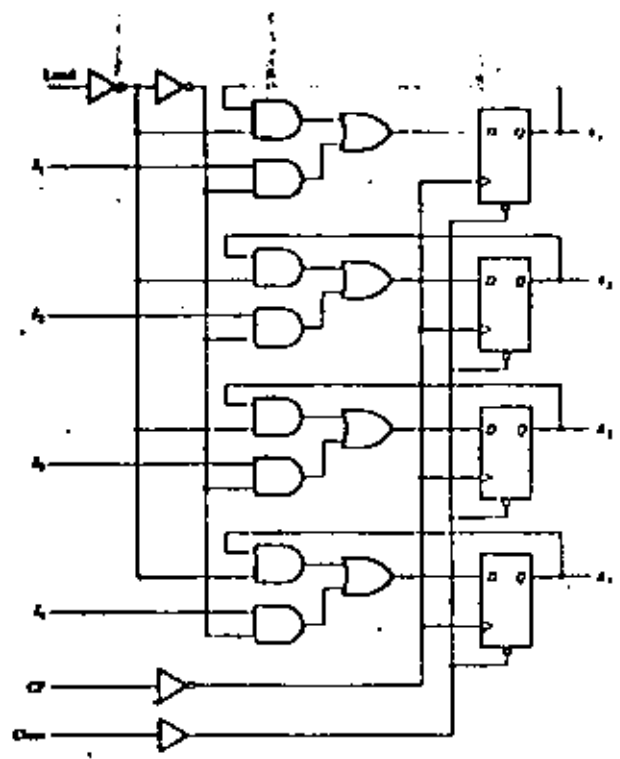

Figure 7-2 Register with parallel load using D flip-flops

•REGISTROS DE CORRIMIENTO.

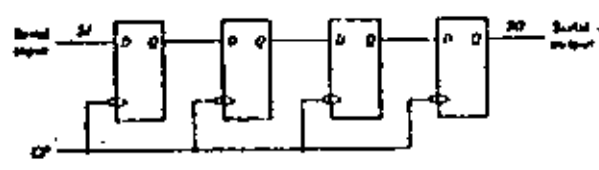

Figure 7-3 Shift register

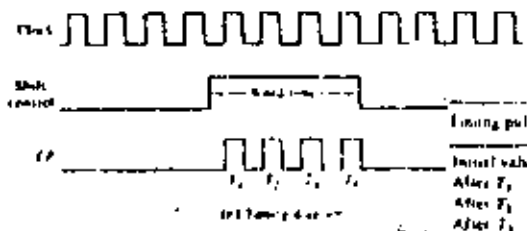
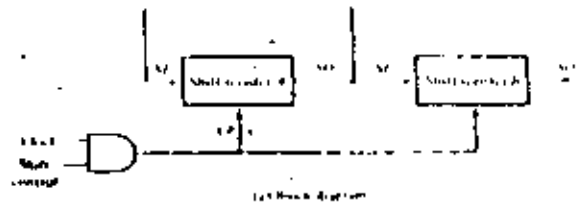

Table 7-1 Serial-to-serial message

Timing pulse	Shift register A	Shift register B	Serial output of B
Initial value	0 0 1 0	0 0 1 0	0
After T ₁	1 1 1 0	0 1 0 0	0
After T ₂	0 1 1 1	1 0 0 0	0
After T ₃	1 0 1 1	0 1 0 0	0
After T ₄	1 0 1 1	1 0 1 1	1

Figure 7-4 Serial transfer from register A to register B

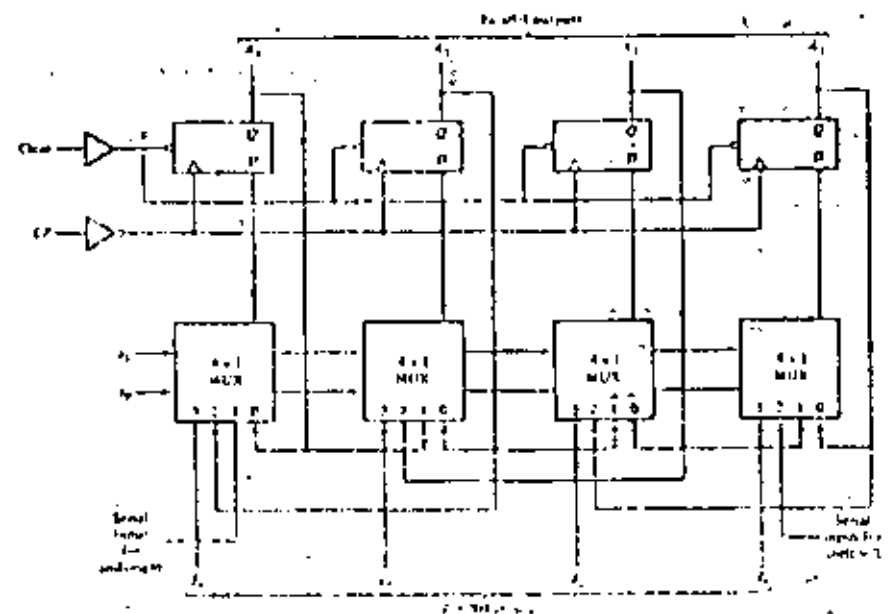

Figure 7-5 Shift register using 4-to-1 MUXes

IX

AGENCIAS DE SERVICIOS
DE LA UNIVERSIDAD DE

XI

CONSEJO ASOCIADO

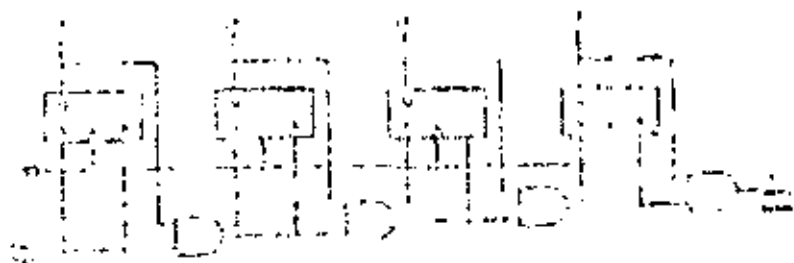
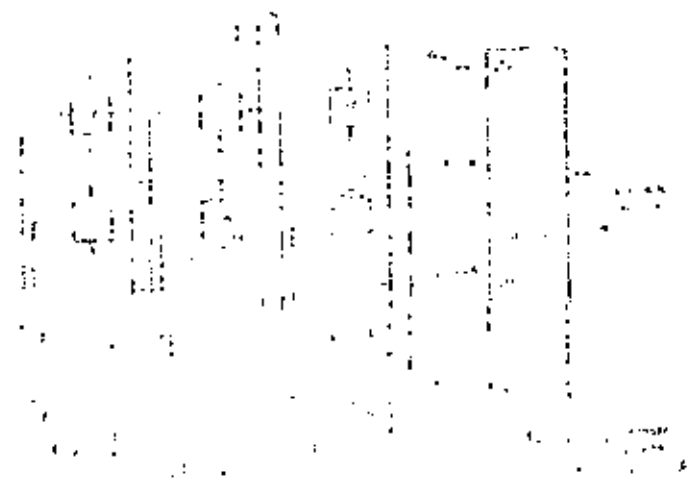

Diagram 1

AGENCIAS DE SERVICIOS DE LA UNIVERSIDAD DE

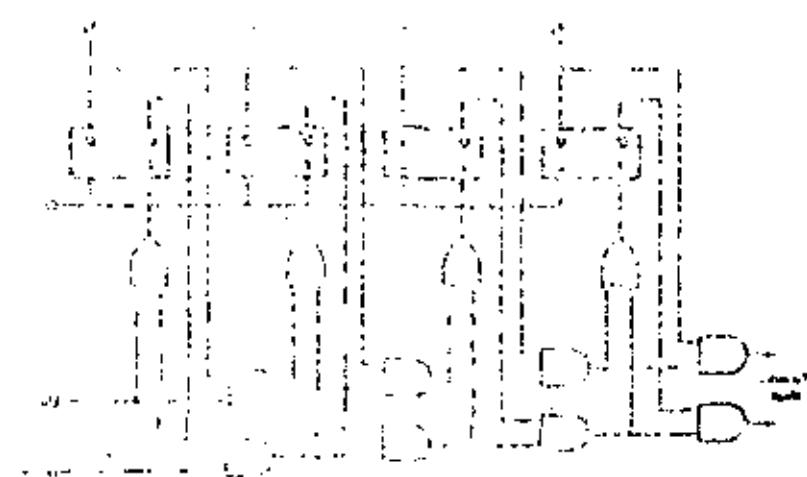

Diagram 2