



UNIVERSIDAD NACIONAL AUTÓNOMA DE MÉXICO
PROGRAMA DE MAESTRÍA Y DOCTORADO EN INGENIERÍA
MECÁNICA – MECATRÓNICA

ANÁLISIS DE UN ROBOT PARALELO DE
SEIS GRADOS DE LIBERTAD ORIENTADO
A LA SIMULACIÓN DE SISMOS

TESIS
QUE PARA OPTAR POR EL GRADO DE:
MAESTRO EN INGENIERÍA

PRESENTA:
CRISTIAN GIOVANNY RANGEL LARA

TUTOR PRINCIPAL
DR. FRANCISCO CUENCA JIMÉNEZ
FACULTAD DE INGENIERÍA

MÉXICO, D. F. ENERO 2015

JURADO ASIGNADO:

Presidente: Dr. González Villela Víctor Javier

Secretario: Dr. Ramírez Reivich Alejandro C.

Vocal: Dr. Cuenca Jiménez Francisco

1^{er}. Suplente: Dr. Velázquez Villegas Fernando

2^{do}. Suplente: M.I. Díaz Hernández Octavio

Lugar o lugares donde se realizó la tesis: FACULTAD DE INGENIERÍA

TUTOR DE TESIS:

DR. FRANCISCO CUENCA JIMÉNEZ

FIRMA

Agradecimientos

*A la Universidad Nacional Autónoma de México,
por permitirme el tan merecido orgullo de ser parte de su gran comunidad estudiantil.*

*A los docentes de la Facultad de Ingeniería,
por sus invaluable enseñanzas e inspiraciones que me acompañan día a día.*

*Al Dr. Francisco Cuenca Jiménez,
por su orientación y apoyo incondicional para la realización de esta tesis,
y sobre todo, por su gran sentido de responsabilidad y enseñanza para con sus alumnos.*

*Así también, se extiende un agradecimiento al programa de becas de CONACYT por el apoyo
económico que permitió dirigir la atención directamente a la realización de este proyecto.*

Resumen

En este trabajo se presenta el análisis de un robot paralelo de 6 grados libertad cuya aplicación final está orientada a la simulación y réplica de movimientos sísmicos. La primera parte del trabajo, consistió en calcular la posición, velocidad y aceleración de las variables de las articulaciones del sistema, a través de las técnicas de la Cinemática Inversa. Para ello, se propuso una trayectoria oscilatoria basada en los movimientos armónicos producidos por las ondas sísmicas.

La segunda parte del trabajo, consistió en encontrar las fuerzas necesaria que deben ejercer los actuadores para mover una carga C a través de la trayectoria anteriormente propuesta, utilizando el método de Euler-Lagrange y el enfoque de la Dinámica Inversa.

Finalmente, se obtuvo el modelo dinámico del robot y se realizaron simulaciones para observar el comportamiento del sistema, verificando que la estructura pudiera seguir la trayectoria propuesta sin perder de vista la evolución de las variables de interés a través del tiempo.

Contenido

Capítulo 1 Generalidades	11
1.1. Introducción	11
1.2. Objetivos	11
1.2.1. Objetivo General	11
1.2.1. Objetivos Particulares	11
1.3. Justificación.....	11
1.3.1. La problemática.....	11
1.3.2. La propuesta	12
1.4. Metodología	13
1.5. Configuración del robot.....	13
Capítulo 2 Análisis Cinemático	15
2.1. Introducción	15
2.2. Grados de Libertad.....	15
2.3. Solución Algebraica.....	16
2.4. Cálculo de la Posición.....	16
2.4.1 Solución del desplazamiento x_{32i}	22
2.4.2 Solución del ángulo ψ_{65i}	25
2.4.3 Solución del ángulo ϕ_{76i}	27
2.4.4 Solución del ángulo ϕ_{1110i}	27
2.4.5 Solución del ángulo ψ_{109i}	28
2.4.6 Solución del ángulo ϕ_{98i}	29
2.5. Cálculo de la Velocidad.....	29
2.5.1 Velocidad del desplazamiento x_{32i}	30
2.5.2 Velocidad del ángulo ψ_{65i}	31

2.5.3 Velocidad del ángulo ϕ_{76i}	32
2.5.4 Velocidad del ángulo ϕ_{1110i}	33
2.5.5 Velocidad del ángulo ψ_{109i}	34
2.5.6 Velocidad del ángulo ϕ_{98i}	35
2.6. Cálculo de la Aceleración.....	36
2.6.1 Aceleración del desplazamiento x_{32i}	37
2.6.2 Aceleración del ángulo ψ_{65i}	39
2.6.3 Aceleración del ángulo ϕ_{76i}	39
2.6.4 Aceleración del ángulo ϕ_{1110i}	40
2.6.5 Aceleración del ángulo ψ_{109i}	41
2.6.6 Aceleración del ángulo ϕ_{98i}	42
Capítulo 3 Análisis Dinámico Formulación Euler-Lagrange.....	43
3.1. Introducción.....	43
3.2. Análisis de Posición y Velocidad de Centros de Gravedad.....	44
3.2.1. Posición y Velocidad de Centro de Gravedad del Cuerpo 1_i	46
3.2.2. Posición y Velocidad de Centro de Gravedad del Cuerpo 2_i	48
3.2.3. Velocidad Angular del Centro de Gravedad del Cuerpo 2_i	50
3.2.4. Posición y Velocidad de Centro de Gravedad del Plato Móvil.....	51
3.2.5. Velocidad Angular del Centro de Gravedad del Plato Móvil.....	52
3.2.6. Posición y Velocidad de Centro de Gravedad de la Carga.....	53
3.2.7. Velocidad Angular del Centro de Gravedad de la Carga.....	55
3.3. Función Lagrangiana.....	55
3.3.1. Desarrollo del Primer Término de la Ecuación de Lagrange.....	56
3.3.2. Desarrollo del Segundo Término de la Ecuación de Lagrange.....	67
3.4. Fuerzas Generalizadas.....	80
3.5. Sustitución de los términos en la Ecuación de Lagrange.....	84
Capítulo 4 Resultados.....	87

4.1. Gráficas de Posición	87
4.2. Gráficas de Velocidad.....	90
4.3. Gráficas de Aceleración	92
4.4. Solución del método Euler-Lagrange.....	94
Capítulo 5 Conclusiones	96
Bibliografía.....	97
Apéndice A Generación de Trayectoria	99
Apéndice B Coeficientes de Ecuaciones de Velocidad	102
Apéndice C Coeficientes de Ecuaciones de Aceleración.....	107
Apéndice D Desarrollo de la Ecuación de Lazo	113
Apéndice E Matriz Jacobiana de Velocidad para x_{32i}	118

Índice de Ilustraciones

Fig. 1.1 Mesa Vibradora y Simulador de Vuelo.....	13
Fig. 1.2 Manipulador Híbrido Cheope.....	13
Fig. 1.3 Configuración del Robot Paralelo.....	14
Fig. 2.1 Sistemas de referencia del inercial al 1i.....	18
Fig. 2.2 Sistemas de referencia del 1i al 5i.....	18
Fig. 2.3 Sistemas de referencia del 5i al 7i.....	19
Fig. 2.4 Sistemas de referencia del 7i al 8i.....	19
Fig. 2.5 Sistemas de referencia del 8i al 11i.....	20
Fig. 2.6 Sistemas de referencia del 11i al 14i.....	20
Fig. 2.7 Ángulos de Euler.....	21
Fig. 2.8 Notación propuesta para denotar claridad en el análisis cinemática.....	21
Fig. 3.1 Cuerpos del robot.....	44
Fig. 3.2 Vectores de centro de gravedad.....	45
Fig. 3.3 Centro de Gravedad del Cuerpo 1i.....	46
Fig. 3.4 Centro de Gravedad del Cuerpo 2i.....	48
Fig. 3.5 Centro de Gravedad de la Plataforma.....	51
Fig. 3.6 Centro de Gravedad de la Carga.....	53
Fig. 4.1 Gráfica para x_{32i}	88
Fig. 4.2 Gráfica para ψ_{65i}	88
Fig. 4.3 Gráfica para ϕ_{76i}	88
Fig. 4.4 Gráfica para ϕ_{98i}	89
Fig. 4.5 Gráfica para ψ_{109i}	89
Fig. 4.6 Gráfica para ϕ_{1110i}	89
Fig. 4.7 Gráfica para x_{32i}	90
Fig. 4.8 Gráfica para ψ_{65i}	90
Fig. 4.9 Gráfica para ϕ_{76i}	90
Fig. 4.10 Gráfica para ϕ_{98i}	91
Fig. 4.11 Gráfica para ψ_{109i}	91
Fig. 4.12 Gráfica para ϕ_{1110i}	91
Fig. 4.13 Gráfica para x_{32i}	92
Fig. 4.14 Gráfica para ψ_{65i}	92

Fig. 4.15 Gráfica para ϕ_{76i}	92
Fig. 4.16 Gráfica para ϕ_{98i}	93
Fig. 4.17 Gráfica para ψ_{109i}	93
Fig. 4.18 Gráfica para ϕ_{1110i}	93
Fig. 4.19 Gráfica de fuerzas de los actuadores.....	94
Fig. 4.20 Gráfica de trabajo mecánico efectuado por la fuerza F_i	95
Fig. 4.21 Gráfica de potencia necesaria en los actuadores.....	95
Fig. 4.21 Gráfica de potencia necesaria en los actuadores.....	95
Fig. 4.21 Gráfica de potencia necesaria en los actuadores.....	95
Fig. 4.21 Gráfica de potencia necesaria en los actuadores.....	95
Fig. A.1 Trayectoria propuesta.....	100

Nomenclatura

- GDL – Grados de Libertad
- $c\theta$ – Cos θ
- $s\theta$ – Sen θ
- \mathbf{r}_a^b – Vector de posición del cuerpo a proyectado en la base b
- $\mathbf{T}_{z1}(x)$ – Matriz de transformación homogénea, para traslación en el eje x
- $\mathbf{T}_{z2}(y)$ – Matriz de transformación homogénea, para traslación en el eje y
- $\mathbf{T}_{z3}(z)$ – Matriz de transformación homogénea, para traslación en el eje z
- $\mathbf{T}_{z4}(\theta_x)$ – Matriz de transformación homogénea, para rotación en el eje x
- $\mathbf{T}_{z5}(\theta_y)$ – Matriz de transformación homogénea, para rotación en el eje y
- $\mathbf{T}_{z6}(\theta_z)$ – Matriz de transformación homogénea, para rotación en el eje z
- \mathbf{T}_{xy} – Matriz de transformación de la base x a la base y
- \mathbf{R}_m^n – Matriz de transformación que proyecta de la base m a la n
- $\boldsymbol{\omega}_i^j$ – Velocidad angular del cuerpo i proyectada en la base j
- $\boldsymbol{\alpha}_i^j$ – Aceleración angular del cuerpo i proyectada en la base j
- \mathbf{I}_{ij} – Matriz de inercia del cuerpo i, de la cadena j
- K – Energía cinética del sistema mecánico.
- U – Energía potencial del sistema mecánico.
- L – Función Lagrangiana
- \mathbf{M}_{ij} – Matriz de elementos de masa del cuerpo i, de la cadena j
- \mathbf{q} – Vector de coordenadas generalizadas
- \mathbf{Q}_j – Vector de fuerzas generalizadas

Capítulo 1

Generalidades

1.1. Introducción

En este capítulo se presentan los objetivos del proyecto de tesis, así como la justificación de los temas a desarrollar, estado del arte y metodología empleada. Los temas desarrollados en este trabajo de tesis son: Análisis Cinemático Inverso y Análisis Dinámico Inverso a partir de la formulación Euler-Lagrange.

1.2. Objetivos

1.2.1. Objetivo General

Obtener un modelo dinámico de una estructura cuya aplicación pueda orientarse a la simulación de sismos característicos de la Ciudad de México. Además, el modelo obtenido debe representar las generalidades del comportamiento del sistema, y que además, permita la aplicación de algún algoritmo de control, de tal manera que se pueda dar continuidad al proyecto, y con esto, obtener una aplicación real que beneficie a la sociedad.

1.2.1. Objetivos Particulares

1. Realizar el Análisis Cinemático utilizando las técnicas de la Cinemática Inversa.
2. Realizar el Análisis Dinámico, obteniendo un modelo dinámico cuya ecuación general permita implementar un algoritmo de control a futuro.

1.3. Justificación

1.3.1. La problemática

Si bien es cierto que el territorio nacional se encuentra sobre una zona sísmica con cinco placas tectónicas que interactúan entre sí (la placa de Norteamérica, placa de Cocos, placa del Pacífico, placa de Rivera y placa del Caribe), es preocupante que en los últimos 14 años la tasa de eventos

sísmicos por año ha ido en aumento. Según los datos del Servicio Sismológico Nacional (SNN), se indica que desde el año 2000 hasta el 2013 se han registrado 129 movimientos de intensidad considerable, de los cuales 51 han sido arriba de los 6 grados Richter. Los sismos con mayor intensidad registrados durante el siglo XXI han llegado inclusive a los 7.6 grados Richter.

Aunque las autoridades hacen todo lo posible para minimizar los daños materiales y humanos, es necesaria una cultura de prevención que permita “educar para crear consciencia, adoptando nuevas conductas para lograr una actitud responsable y de respeto por la protección de las vidas”. Actualmente, la única cultura de prevención sísmica instaurada en México se basa en la planificación y ejecución de *simulacros*, los cuales son ensayos de actuación en caso de emergencia, siguiendo un plan previamente establecido basado en procedimientos de seguridad y protección. Sin embargo, únicamente sirven para acostumar a la población a adoptar rutinas de acción convenientes, sin que sea sometida a verdaderas situaciones con afectaciones sísmicas.

1.3.2. La propuesta

Sabemos que hoy en día han surgido diferentes variedades de robots cuya finalidad es solventar una tarea en específico. Éste “arranque” se debe en gran medida a los avances tecnológicos de las últimas décadas, especialmente en el campo de la electrónica y la mecánica computacional, que han podido arrojar métodos, herramientas y dispositivos que permiten desarrollar sistemas complejos con gran precisión y poca probabilidad de falla.

Actualmente existen robots de todo tipo, orientados a la medicina, industria, producción en serie, etc., los cuales permiten tener gran calidad y precisión en el producto o servicio del que se trate. Algunos de ellos inclusive se dedican realizar simulaciones de situaciones físicas, permitiendo realizar estudios a fondo bajo ciertas condiciones externas. Tal es el caso de las mesas vibratorias y los simuladores de vuelo (Fig. 1.1).

El proyecto sobre el cuál se basa éste trabajo, es conocido como Cheope, un robot 2-en-1 cuya estructura principal consiste de un robot paralelo, la cual le permite realizar la mayoría de los movimientos relativamente amplios; por otra parte, la estructura secundaria es un robot serial, colocado a manera de efector final, el cual está orientado a realizar los movimientos más sutiles y precisos del sistema (Fig. 1.2).



Fig. 1.1 Mesa Vibradora y Simulador de Vuelo



Fig. 1.2 Manipulador Híbrido Cheope

Este trabajo presenta el análisis de un robot paralelo de seis grados de libertad cuyo objetivo radica en realizar simulaciones de sismos, que permitan a su vez fomentar la cultura de prevención permitiendo que la sociedad experimente réplicas de sismos con diferentes magnitudes.

1.4. Metodología

- 1) Análisis Cinemático
 - a) Análisis de Posición
 - b) Análisis de Velocidad
 - c) Análisis de Aceleración

- 2) Análisis Dinámico
 - a) Formulación Euler-Lagrange
 - a.1) Energía Cinética
 - a.2) Energía Potencial
 - a.3) Función Lagrangiana
 - a.4) Fuerzas Generalizadas
 - b) Simulación por Software

1.5. Configuración del robot

El robot paralelo sobre el cual se realizará el análisis se encuentra definido por seis cadenas cinemáticas, las cuales constan cada una de un actuador lineal y un brazo unido al efector final. El actuador lineal se desplaza a lo largo de un riel fijo instalado sobre la base del sistema, y se encuentra unido al brazo por medio de una junta esférica. El efector final consiste en una plataforma móvil cuya posición dependerá directamente de la ubicación y orientación de cada

uno de los seis brazos. Dichos brazos se encuentran unidos a la plataforma por medio de juntas esféricas (Fig. 1.3). Debido a que las seis cadenas cinemáticas son idénticas, sólo será descrita a detalle una de ellas, identificándola por medio del iterador i . Para éste análisis, se considera que todos los eslabones, así como la base y la plataforma móvil son cuerpos rígidos.

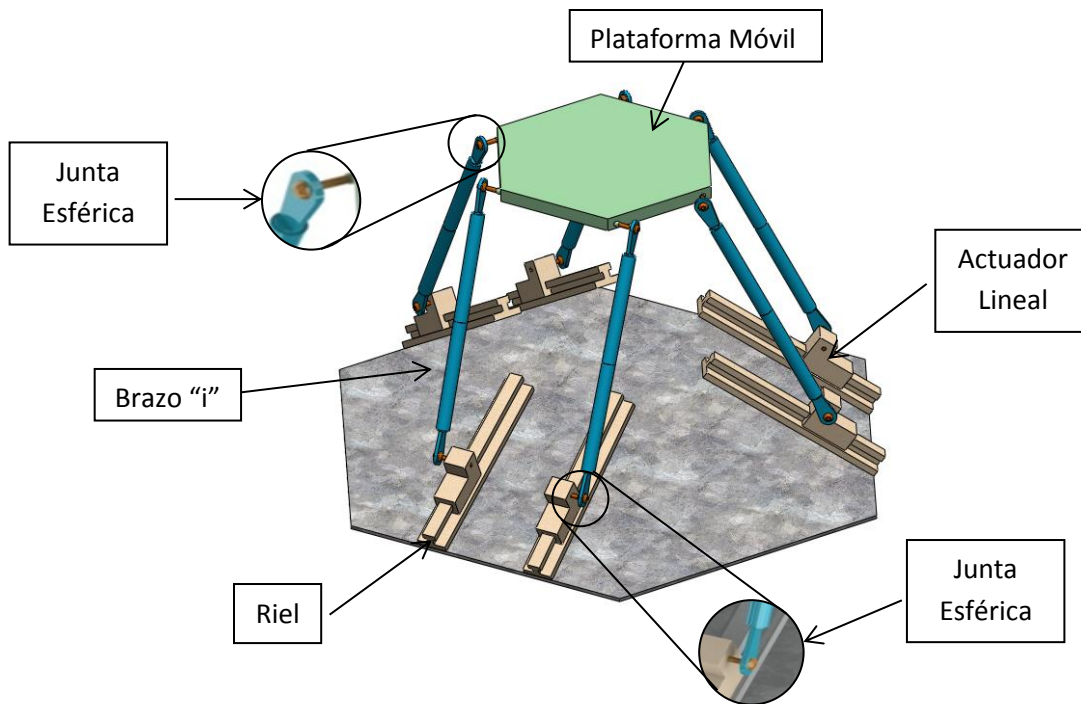

Fig. 1.3 Configuración del Robot Paralelo

Capítulo 2

Análisis Cinemático

2.1. Introducción

La cinemática es la parte de la mecánica que estudia las leyes del movimiento de los cuerpos sin tener en cuenta los efectos extremos, fuerzas y/o torques que lo causan, limitándose, esencialmente, al estudio de la trayectoria en función del tiempo, es decir, trata la posición, velocidad y aceleración de los cuerpos.

Sistemas de referencia son empleados para definir la cinemática inversa de un cuerpo. En la descripción del presente trabajo de investigación se emplean dos sistemas de referencia cartesianos, sistema de referencia fijos o marcos inerciales y sistemas de referencia relativos o marcos locales. En el presente capítulo se desarrolla el análisis de posición, velocidad y aceleración de los ángulos encontrados en las juntas del robot.

2.2. Grados de Libertad

Los grados de libertad de un mecanismo son el número de parámetros independientes o entradas necesarias para especificar la configuración de un mecanismo completamente. Los grados de libertad de un mecanismo paralelo pueden ser determinados con la aplicación de la fórmula Chebyshev-Grübler-Kutzbach:

$$L = 6(b - g - 1) + \sum_k f_k$$

Donde:

b = Número de cuerpos del sistema.

g = Número de juntas del mecanismo.

f_k = Número de grados de libertad de la junta k .

Por lo tanto, para la plataforma se tiene:

$$\begin{aligned}
 b &= 14 \\
 g &= 18 \\
 \sum_k f_k &= 36
 \end{aligned}$$

Sustituyendo los valores se tiene:

$$L = 6(14 - 18 - 1) + 36$$

$$L = 6$$

Por lo tanto el sistema robótico tiene 6 grados de libertad.

2.3. Solución Algebraica

En ésta sección se obtendrán de forma cerrada las variables actuadas y no actuadas. En una ecuación de forma cerrada se expresan las variables incógnitas como una función de las variables de entrada conocidas, en este caso particular, las variables incógnitas son las posiciones, velocidades y aceleraciones angulares en cada una de las juntas que conforman el manipulador; y las variables de entrada conocidas son las que definen la posición y orientación del efector final en el espacio. De ésta manera se tendrá un sistema de ecuaciones escalares de $n \times n$, dentro del cual se despejarán cada una de las incógnitas.

2.4. Cálculo de la Posición

En el problema cinemático inverso de la posición, se tiene que, dada la posición $(x_p, y_p, z_p, \theta_p, \psi_p, \phi_p)$ del plato móvil, hallar la posición de las variables $(x_{32i}, \psi_{65i}, \phi_{76i}, \phi_{98i}, \psi_{109i}, \phi_{110i})$ que se encuentran en las juntas del robot. Dicho análisis es esencial para el control de posición de robots paralelos.

Para hacer el análisis del robot se tomaron como herramienta las matrices de transformación homogéneas, las cuales nos proporcionan desplazamiento y rotación de un cuerpo en el espacio. La matriz de transformación homogénea (Stejskal, y otros, 1996) es una matriz de 4×4 que tiene la siguiente definición:

$$T = \begin{bmatrix} R & d \\ \mathbf{0} & 1 \end{bmatrix} \quad (2.1)$$

Donde:

$R =$ Matriz de Rotación (3×3).

$d =$ Vector de Desplazamiento (3×1).

$\mathbf{0} =$ Vector cero (1×3).

La matriz \mathbf{R} de 3x3 denota la orientación de una base móvil respecto a una base de referencia, el vector \mathbf{d} de 3x1 denota la posición del origen de la base móvil relativa a la base de referencia, el vector $\mathbf{0}$ de 1x3 denota el vector cero. Las matrices de transformación de traslación en los ejes x , y y z respectivamente son:

$$\mathbf{T}_{z1}(x) = \begin{bmatrix} 1 & 0 & 0 & x \\ 0 & 1 & 0 & 0 \\ 0 & 0 & 1 & 0 \\ 0 & 0 & 0 & 1 \end{bmatrix} \quad \mathbf{T}_{z2}(y) = \begin{bmatrix} 1 & 0 & 0 & 0 \\ 0 & 1 & 0 & y \\ 0 & 0 & 1 & 0 \\ 0 & 0 & 0 & 1 \end{bmatrix} \quad \mathbf{T}_{z3}(z) = \begin{bmatrix} 1 & 0 & 0 & 0 \\ 0 & 1 & 0 & 0 \\ 0 & 0 & 1 & z \\ 0 & 0 & 0 & 1 \end{bmatrix}$$

Las matrices de transformación de rotación en los ejes x , y y z respectivamente son:

$$\mathbf{T}_{z4}(\theta_x) = \begin{bmatrix} 1 & 0 & 0 & x \\ 0 & c\theta_x & -s\theta_x & 0 \\ 0 & s\theta_x & c\theta_x & 0 \\ 0 & 0 & 0 & 1 \end{bmatrix} \quad \mathbf{T}_{z5}(\theta_y) = \begin{bmatrix} c\theta_y & 0 & s\theta_y & 0 \\ 0 & 1 & 0 & y \\ -s\theta_y & 0 & c\theta_y & 0 \\ 0 & 0 & 0 & 1 \end{bmatrix} \quad \mathbf{T}_{z6}(\theta_z) = \begin{bmatrix} c\theta_z & -s\theta_z & 0 & 0 \\ s\theta_z & c\theta_z & 0 & 0 \\ 0 & 0 & 1 & z \\ 0 & 0 & 0 & 1 \end{bmatrix}$$

Debido a la simetría entre las cadenas cinemáticas, se describirá a detalle sólo una de las seis que conforman el robot, y se podrán diferenciar con ayuda del iterador i .

En las figuras 2.1, 2.2, 2.3, 2.4, 2.5 y 2.6 se muestra la secuencia en la cual se fueron generando, a partir de la base inercial $(\mathbf{i}_0, \mathbf{j}_0, \mathbf{k}_0)$ las bases locales. Aplicando una matriz de transformación de giro en el eje z , y una transformación de giro en el eje y , se forman respectivamente las bases 1i, 2i, es decir:

$$\mathbf{T}_{02i} = \mathbf{T}_{z6}(\gamma_{1i})\mathbf{T}_{z5}(\beta_{2i})$$

Para encontrar las bases 3i y 4i, es necesario aplicar una transformación de traslación a lo largo del eje x , la cual representa el movimiento del actuador lineal; posteriormente, basta con realizar una transformación de traslación a través del eje y para seleccionar la cadena cinemática por la que llegaremos al efector final, esto es:

$$\mathbf{T}_{24i} = \mathbf{T}_{z1}(x_{32i})\mathbf{T}_{z2}(b_{43i})$$

De la misma forma, para obtener la base 5i, basta con emplear una transformación a lo largo del eje z . Para las bases 6i y 7i, encontradas en la primera junta esférica, es necesario usar dos transformaciones de rotación continuas, la primera utilizando el eje y y la segunda usando al eje z . Se tiene entonces:

$$\mathbf{T}_{47i} = \mathbf{T}_{z3}(c_{54i})\mathbf{T}_{z5}(\psi_{65i})\mathbf{T}_{z6}(\phi_{76i})$$

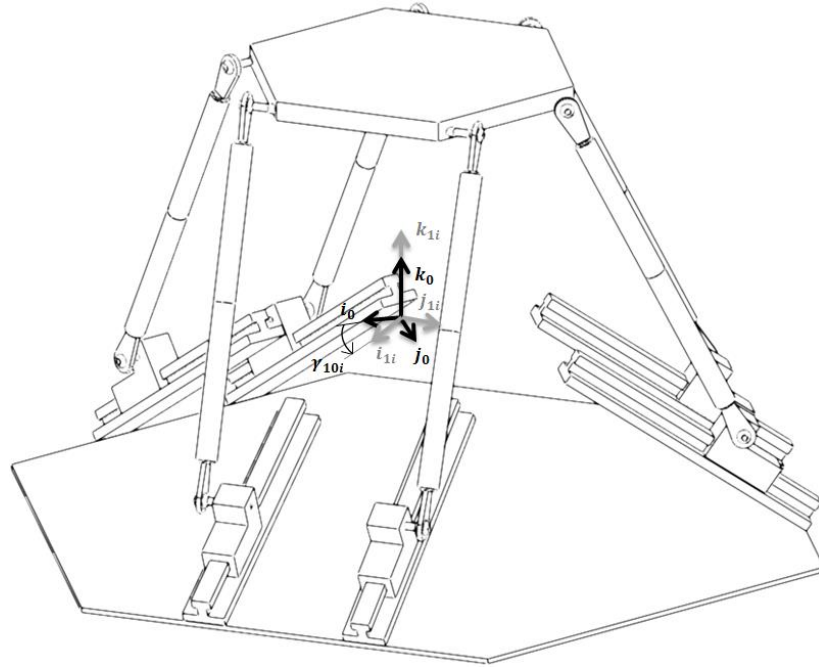

Fig. 2.1 Sistemas de referencia del inercial al 1i

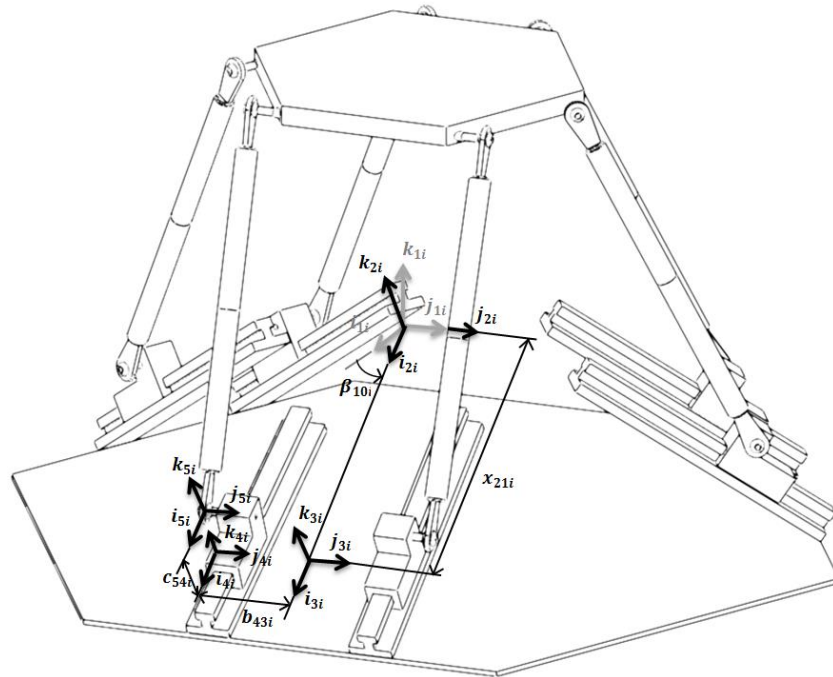

Fig. 2.2 Sistemas de referencia del 1i al 5i

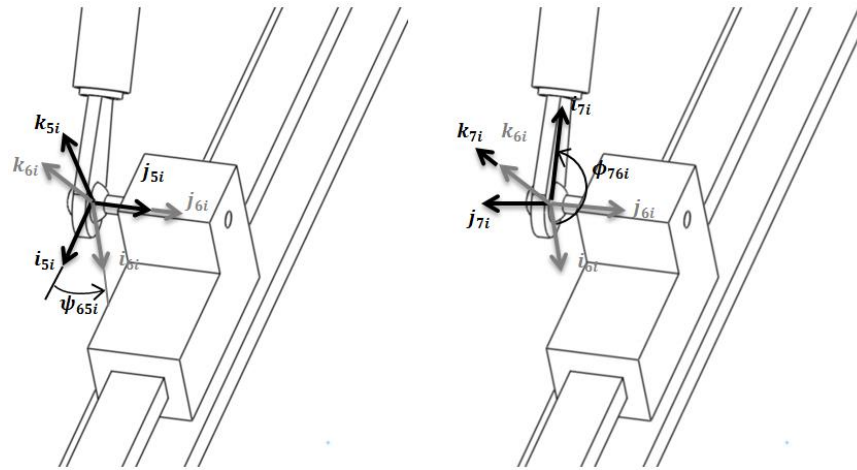

Fig. 2.3 Sistemas de referencia del 5i al 7i

En la figura 2.4 y 2.5, se muestra como fueron generadas las bases 8i, 9i 10i y 11i, las últimas tres localizadas en la segunda junta esférica.

$$T_{711i} = T_{z1}(a_{87i})T_{z6}(\phi_{98i})T_{z5}(\psi_{109i})T_{z6}(\phi_{1110i})$$

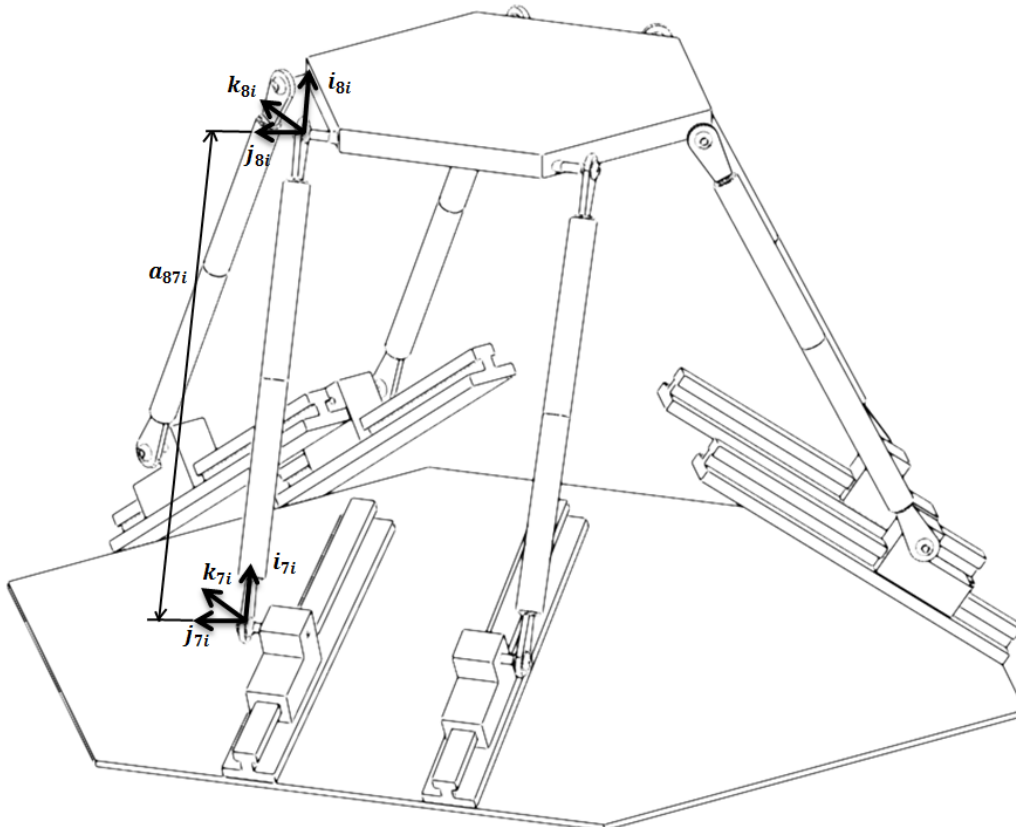

Fig. 2.4 Sistemas de referencia del 7i al 8i

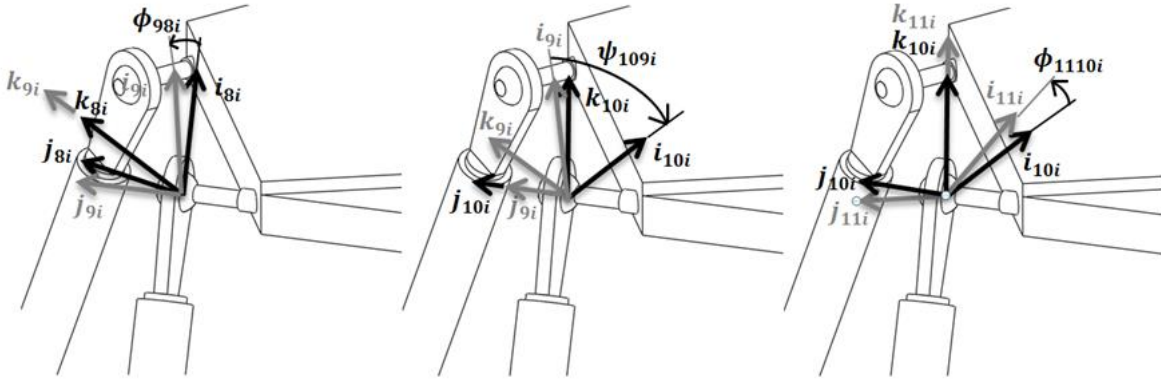

Fig. 2.5 Sistemas de referencia del 8i al 11i

Para las bases 12i, 13i y 14i, las cuales se encuentran en el plato móvil (fig. 2.6), se tiene:

$$T_{1114i} = T_{z6}(\gamma_{1211i})T_{z1}(a_{1312i})T_{z6}(\gamma_{1413i})$$

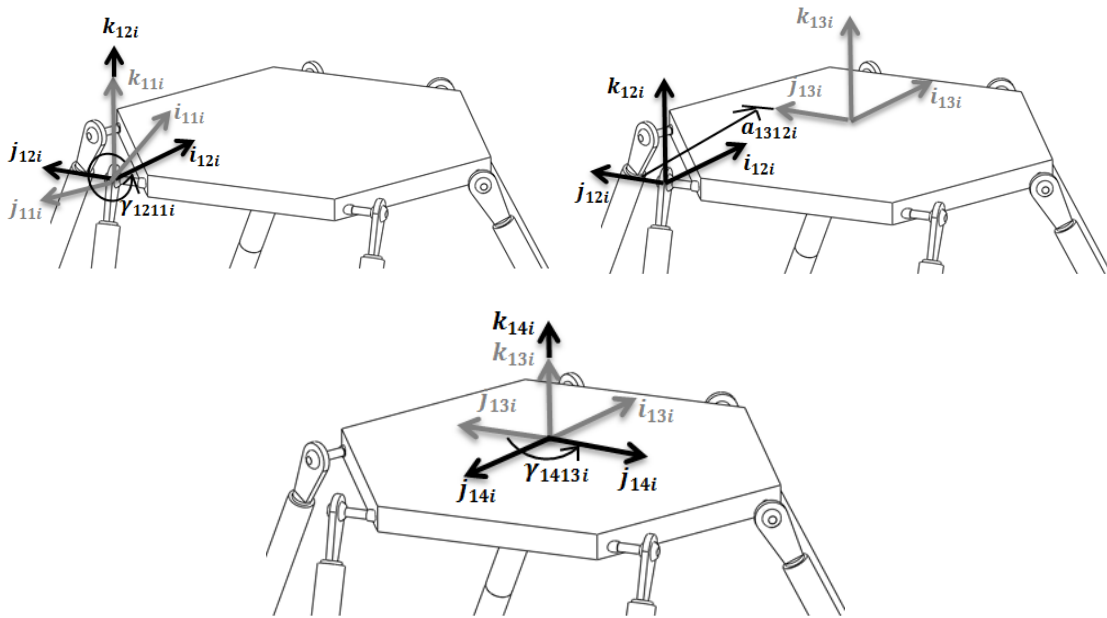

Fig. 2.6 Sistemas de referencia del 11i al 14i

Por último, para generar una ecuación de lazo se requiere generar las bases que nos permitan llegar de la base inercial a la base 14i sin pasar por los brazos del robot, esto es, tomando como datos la posición y orientación deseados del efector final. En la figura 2.7 se muestran las bases generadas para la orientación del plato, donde las transformaciones requeridas son las siguientes:

$$T_p = T_{z1}(x_p)T_{z2}(y_p)T_{z3}(z_p)T_{z4}(\theta_p)T_{z5}(\psi_p)T_{z6}(\phi_p)$$

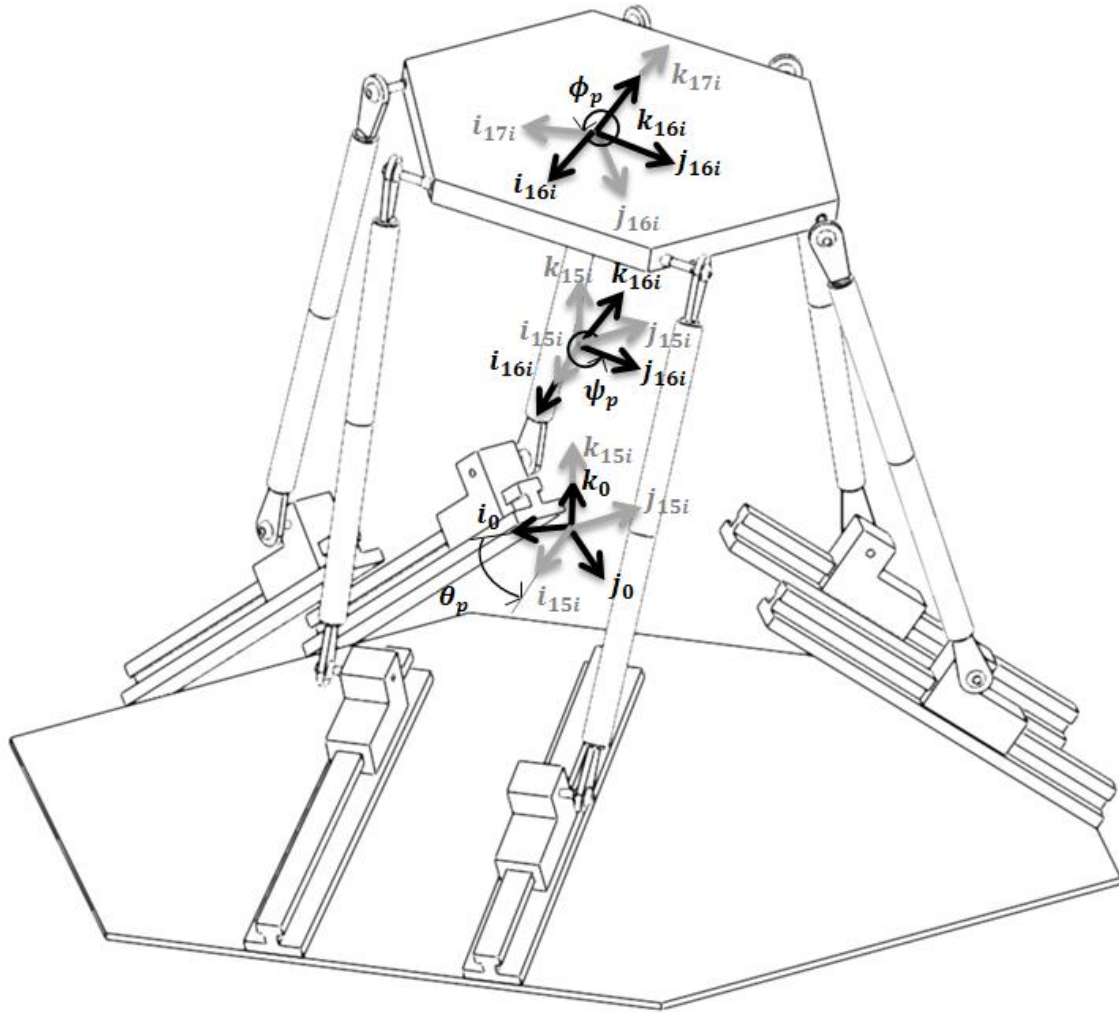

Fig. 2.7 Ángulos de Euler

En la figura 2.7 no se muestran las traslaciones x , y y z ya que son paralelas a la inercial, por lo que únicamente se muestran las bases para la orientación de la plataforma. La notación propuesta se expone en las siguientes tablas (Fig. 2.8):

Ángulos asociados a rotaciones				Distancias asociadas a traslaciones			
	Eje X	Eje Y	Eje Z	Eje X	Eje Y	Eje Z	
Constantes	δ	β	γ	a	b	c	
Variables	θ	ψ	φ	x	y	z	

Fig. 2.8 Notación propuesta para denotar claridad en el análisis cinemática

De ésta manera, podemos observar que las incógnitas a determinar son tanto las posiciones de los actuadores lineales, como los ángulos de las juntas esféricas, las cuales en conjunto nos permiten orientar la plataforma en el espacio, siendo estas:

$$(x_{32i}, \psi_{65i}, \phi_{76i}, \phi_{98i}, \psi_{109i}, \phi_{1110i}) \quad \text{donde: } i = 1,2,3,4,5,6.$$

A partir de éste resultado, se tienen en total 36 variables por calcular, de las cuales 6 son actuadas tal y como se determinó gracias a los grados de libertad. Se establece además, a las variables x_{32i} como las variables actuadas del mecanismo, ya que la base en la que se encuentran definidas está adherida directamente al actuador lineal.

2.4.1 Solución del desplazamiento x_{32i}

Para la obtención de dicho desplazamiento se requiere obtener una ecuación escalar que se encuentre sólo en función de las longitudes y ángulos conocidos (propios de la geometría del mecanismo). Por esta razón, se optó por obtener el vector de posición de la segunda junta esférica, ya que éste nos ayudaría a encontrar una ecuación que nos permitiría determinar el valor del desplazamiento del actuador. Se plantearon dos recorridos: el primero a través del actuador y del brazo "i", y el segundo a través de la plataforma móvil. A continuación, se describirá el proceso para obtener dicho vector.

Partiendo de la ecuación generada a través de las matrices de transformación homogéneas en la que se llegó a la plataforma del robot, tenemos:

$$\mathbf{T}_{02i}\mathbf{T}_{24i}\mathbf{T}_{47i}\mathbf{T}_{711i}\mathbf{T}_{1114i} = \mathbf{T}_p \quad (2.2)$$

Si deseamos obtener una ecuación similar, pero esta vez llegando a la posición de la segunda junta esférica, basta con postmultiplicar \mathbf{T}_{1114i}^{-1} en ambos miembros de la ecuación 2.2:

$$\mathbf{T}_{02i}\mathbf{T}_{24i}\mathbf{T}_{47i}\mathbf{T}_{711i} = \mathbf{T}_p\mathbf{T}_{1114i}^{-1} \quad (2.3)$$

Por otra parte, sabemos que:

$$\mathbf{T}_{711i} = \mathbf{T}_{z1}(a_{87i})\mathbf{T}_{z6}(\phi_{98i})\mathbf{T}_{z5}(\psi_{109i})\mathbf{T}_{z6}(\phi_{1110i}) \quad (2.4)$$

$$\mathbf{T}_{1114i}^{-1} = (\mathbf{T}_{z6}(\gamma_{1211i})\mathbf{T}_{z1}(a_{1312i})\mathbf{T}_{z6}(\gamma_{1413i}))^{-1} = \mathbf{T}_{z6}^{-1}(\gamma_{1413i})\mathbf{T}_{z1}^{-1}(a_{1312i})\mathbf{T}_{z6}^{-1}(\gamma_{1211i})$$

Tras sustituir las ecuaciones 2.4 en 2.3, tenemos:

$$\mathbf{T}_{02i}\mathbf{T}_{24i}\mathbf{T}_{47i}(\mathbf{T}_{z1}(a_{87i})\mathbf{T}_{z6}(\phi_{98i})\mathbf{T}_{z5}(\psi_{109i})\mathbf{T}_{z6}(\phi_{1110i})) = \mathbf{T}_p(\mathbf{T}_{z6}^{-1}(\gamma_{1413i})\mathbf{T}_{z1}^{-1}(a_{1312i})\mathbf{T}_{z6}^{-1}(\gamma_{1211i})) \quad (2.5)$$

Puesto que únicamente nos interesa extraer el vector de posición de la segunda junta esférica, al recorrer la cadena cinemática a través del actuador, podemos observar que es posible prescindir de las transformaciones $\mathbf{T}_{z6}(\phi_{98i})$, $\mathbf{T}_{z5}(\psi_{109i})$ y $\mathbf{T}_{z6}(\phi_{1110i})$, ya que únicamente orientan los marcos de referencia de la junta, sin modificar su posición final. Aplicando la misma lógica, al recorrer la cadena cinemática a través de la plataforma, nos damos cuenta que también es posible omitir la transformación $\mathbf{T}_{z6}^{-1}(\gamma_{1211i})$, puesto que ya nos encontramos en la posición de la junta esférica.

Aplicando dichos cambios a la ecuación 2.5:

$$\mathbf{T}_{02i}\mathbf{T}_{24i}\mathbf{T}_{47i}\mathbf{T}_{z1}(a_{87i}) = \mathbf{T}_p\mathbf{T}_{z6}^{-1}(\gamma_{1413i})\mathbf{T}_{z1}^{-1}(a_{1312i})$$

Despejando las incógnitas de la primera junta esférica:

$$\mathbf{T}_{47i}\mathbf{T}_{z1}(a_{87i}) = (\mathbf{T}_{02i}\mathbf{T}_{24i})^{-1}\mathbf{T}_p\mathbf{T}_{z6}^{-1}(\gamma_{1413i})\mathbf{T}_{z1}^{-1}(a_{1312i})$$

Desarrollando \mathbf{T}_{47i} y acomodando la expresión:

$$\begin{aligned} \mathbf{T}_{z3}(c_{54i})\mathbf{T}_{z5}(\psi_{65i})\mathbf{T}_{z6}(\phi_{76i})\mathbf{T}_{z1}(a_{87i}) &= \mathbf{T}_{24i}^{-1}\mathbf{T}_{02i}^{-1}\mathbf{T}_p\mathbf{T}_{z6}^{-1}(\gamma_{1413i})\mathbf{T}_{z1}^{-1}(a_{1312i}) \\ \mathbf{T}_{z5}(\psi_{65i})\mathbf{T}_{z6}(\phi_{76i})\mathbf{T}_{z1}(a_{87i}) &= (\mathbf{T}_{z3}(c_{54i}))^{-1}\mathbf{T}_{24i}^{-1}\mathbf{T}_{02i}^{-1}\mathbf{T}_p\mathbf{T}_{z6}^{-1}(\gamma_{1413i})\mathbf{T}_{z1}^{-1}(a_{1312i}) \end{aligned} \quad (2.6)$$

Se define la siguiente matriz homogénea con elementos constantes:

$$\mathbf{T}_{cte} = \mathbf{T}_{02i}^{-1}\mathbf{T}_p\mathbf{T}_{z6}^{-1}(\gamma_{1413i})\mathbf{T}_{z1}^{-1}(a_{1312i}) = \begin{bmatrix} A & B & C & D \\ E & F & G & H \\ I & J & K & L \\ 0 & 0 & 0 & 1 \end{bmatrix} \quad (2.7)$$

Sustituyendo la expresión 2.7 en 2.6:

$$\mathbf{T}_{z5}(\psi_{65i})\mathbf{T}_{z6}(\phi_{76i})\mathbf{T}_{z1}(a_{87i}) = (\mathbf{T}_{z3}(c_{54i}))^{-1}\mathbf{T}_{24i}^{-1}\mathbf{T}_{cte} \quad (2.8)$$

Se sabe que la cuarta columna de toda matriz de transformación homogénea contiene la información relacionada con la posición, sin tomar en cuenta la orientación del sistema de referencia. Para extraer la información de la posición de la segunda junta esférica, basta con expresar la ecuación 2.8 de la siguiente manera:

$$\mathbf{T}_{z5}(\psi_{65i})\mathbf{T}_{z6}(\phi_{76i})\mathbf{T}_{z1}(a_{87i})\mathbf{n} = (\mathbf{T}_{z3}(c_{54i}))^{-1}\mathbf{T}_{24i}^{-1}\mathbf{T}_{cte}\mathbf{n} \quad (2.9)$$

Donde:

$$\mathbf{n} = [0 \quad 0 \quad 0 \quad 1]^T$$

Luego entonces, tenemos:

$$\begin{bmatrix} D - x_{32i} \\ H - b_{43i} \\ -c_{54i} + L \\ 1 \end{bmatrix} = \begin{bmatrix} a_{87i}c\phi_{76i}c\psi_{65i} \\ a_{87i}s\phi_{76i} \\ -a_{87i}c\phi_{76i}s\psi_{65i} \\ 1 \end{bmatrix} \quad (2.10)$$

Es posible extraer los vectores de posición aplicando la siguiente transformación:

$$\mathbf{T}_{3D}(\mathbf{u}) = \mathbf{u}' \quad (2.11)$$

Dónde:

$$\mathbf{u} = \begin{bmatrix} u_x \\ u_y \\ u_z \\ 1 \end{bmatrix} \quad \mathbf{u}' = \begin{bmatrix} u_x \\ u_y \\ u_z \end{bmatrix}$$

Aplicando la transformación 2.11 a la ecuación 2.10, obtenemos los siguientes vectores:

$$\mathbf{p}_1 = \begin{bmatrix} D - x_{32i} \\ H - b_{43i} \\ -c_{54i} + L \end{bmatrix} \quad \mathbf{p}_2 = \begin{bmatrix} a_{87i}c\phi_{76i}c\psi_{65i} \\ a_{87i}s\phi_{76i} \\ -a_{87i}c\phi_{76i}s\psi_{65i} \end{bmatrix}$$

Igualando los módulos de los vectores \mathbf{p}_1 y \mathbf{p}_2 obtenemos:

$$\sqrt{\mathbf{p}_1^T \mathbf{p}_1} = \sqrt{\mathbf{p}_2^T \mathbf{p}_2}$$

$$\mathbf{p}_1^T \mathbf{p}_1 = \mathbf{p}_2^T \mathbf{p}_2$$

Sustituyendo los valores de \mathbf{p}_1 y \mathbf{p}_2 , y desarrollando:

$$a_{87i} = D^2 + (-c_{54i} + L)^2 + (H - b_{43i})^2 - 2Dx_{32i} + x_{32i}^2$$

Renombrando, tenemos:

$$A_{1i}x_{32i}^2 + B_{1i}x_{32i} + D_{1i} = a_{87i}^2 \quad (2.12)$$

Donde:

$$A_{1i} = 1 \quad B_{1i} = -2D \quad D_{1i} = D^2 + (-c_{54i} + L)^2 + (H - b_{43i})^2$$

Finalmente, hemos obtenido una expresión cuadrática cuya única variable es el desplazamiento del actuador lineal, es decir:

$$A_{1i}x_{32i}^2 + B_{1i}x_{32i} + (D_{1i} - a_{87i}^2) = 0 \quad (2.13)$$

Donde:

$$\begin{aligned} A_{1i} &= 1 \\ B_{1i} &= 2(s\beta_{21i}(z_p + a_{1312i}s(\gamma_{1413i} - \phi_p)s\theta_p + a_{1312i}c(\gamma_{1413i} - \phi_p)c\theta_p s\psi_p) - c\beta_{21i}(c\gamma_{10i}(x_p \\ &\quad - a_{1312i}c(\gamma_{1413i} - \phi_p)c\psi_p) + s\gamma_{10i}(\gamma_p + a_{1312i}s(\gamma_{1413i} - \phi_p)c\theta_p - a_{1312i}c(\gamma_{1413i} \\ &\quad - \phi_p)s\theta_p s\psi_p))) \\ D_{1i} &= (-c_{54i} + c\gamma_{10i}(x_p - a_{1312i}c(\gamma_{1413i} - \phi_p)c\psi_p)s\beta_{21i} + (\gamma_p + a_{1312i}s(\gamma_{1413i} - \phi_p)c\theta_p)s\beta_{21i}s\gamma_{10i} \\ &\quad + c\beta_{21i}(z_p + a_{1312i}s(\gamma_{1413i} - \phi_p)s\theta_p) + a_{1312i}c(\gamma_{1413i} - \phi_p)(c\beta_{21i}c\theta_p - s\beta_{21i}s\gamma_{10i}s\theta_p)s\psi_p)^2 \\ &\quad + (-b_{43i} + (-x_p + a_{1312i}c(\gamma_{1413i} - \phi_p)c\psi_p)s\gamma_{10i} + c\gamma_{10i}(\gamma_p + a_{1312i}s(\gamma_{1413i} - \phi_p)c\theta_p \\ &\quad - a_{1312i}c(\gamma_{1413i} - \phi_p)s\theta_p s\psi_p))^2 \\ &\quad + (s\beta_{21i}(z_p + a_{1312i}s(\gamma_{1413i} - \phi_p)s\theta_p + a_{1312i}c(\gamma_{1413i} - \phi_p)c\theta_p s\psi_p) - c\beta_{21i}(c\gamma_{10i}(x_p \\ &\quad - a_{1312i}c(\gamma_{1413i} - \phi_p)c\psi_p) + s\gamma_{10i}(\gamma_p + a_{1312i}s(\gamma_{1413i} - \phi_p)c\theta_p - a_{1312i}c(\gamma_{1413i} \\ &\quad - \phi_p)s\theta_p s\psi_p)))^2 \end{aligned} \quad (2.14)$$

La solución de la ecuación 2.13 se muestra a continuación:

$$x_{32i} = \frac{-B_{1i} + \sqrt{4 A_{1i} a_{87i}^2 + B_{1i}^2 - 4 A_{1i} D_{1i}}}{2 A_{1i}} \quad (2.15)$$

2.4.2 Solución del ángulo ψ_{65i}

Para la obtención de ésta variable, requiere obtener nuevamente una ecuación escalar que se encuentre sólo en función de parámetros y variables conocidas. Para lograr éste objetivo, es posible utilizar de nueva cuenta las transformaciones definidas en el sistema. Partimos de la siguiente ecuación matricial para llegar a la segunda junta esférica:

$$\mathbf{T}_{47i}\mathbf{T}_{z1}(a_{87i}) = (\mathbf{T}_{02i}\mathbf{T}_{24i})^{-1}\mathbf{T}_p(\mathbf{T}_{z1}(a_{1312i})\mathbf{T}_{z6}(\gamma_{1413i}))^{-1} \quad (2.16)$$

En ésta ecuación encontramos las siguientes transformaciones conocidas:

$$\mathbf{T}_{02i}, \mathbf{T}_{24i}, \mathbf{T}_{z1}(a_{1312i}), \mathbf{T}_{z6}(\gamma_{1413i})$$

Ya que además de contener distancias y ángulos constantes, contienen el desplazamiento variable x_{32i} calculado en el apartado anterior. Por otra parte, el miembro izquierdo de la ecuación 2.16 contiene la información de los ángulos de la junta universal, por lo que es posible utilizarla para despejar las variables. Dicho esto, se procede a obtener la información de la posición de la junta universal de la siguiente manera:

$$\mathbf{T}_{47i}\mathbf{T}_{z1}(a_{87i})\mathbf{n} = (\mathbf{T}_{02i}\mathbf{T}_{24i})^{-1}\mathbf{T}_p(\mathbf{T}_{z1}(a_{1312i})\mathbf{T}_{z6}(\gamma_{1413i}))^{-1}\mathbf{n} \quad (2.17)$$

Siendo que el lado derecho de la ecuación 2.17 es conocido, se puede renombrar de la siguiente forma:

$$\mathbf{T}_{47i}\mathbf{T}_{z1}(a_{87i})\mathbf{n} = \mathbf{T}_{total}$$

Donde:

$$\mathbf{T}_{total} = \begin{bmatrix} X_i \\ Y_i \\ Z_i \\ 1 \end{bmatrix}$$

Tras realizar las operaciones del miembro izquierdo, se obtiene el siguiente resultado.

$$\begin{bmatrix} a_{87i}c\phi_{76i}c\psi_{65i} \\ a_{87i}s\phi_{76i} \\ c_{54i} - a_{87i}c\phi_{76i}s\psi_{65i} \\ 1 \end{bmatrix} = \begin{bmatrix} X_i \\ Y_i \\ Z_i \\ 1 \end{bmatrix} \quad (2.18)$$

Para resolver el ángulo ψ_{65i} , se toman las componentes 1 y 3 de cada lado de la ecuación 2.18.

Posteriormente, se despejan $\sin(\psi_{65i})$ y $\cos(\psi_{65i})$, y empleando la función tangente se obtiene:

$$\tan \psi_{65i} = \frac{s\psi_{65i}}{c\psi_{65i}} = -\frac{c_{54i} - Z_i}{X_i} \quad (2.19)$$

Despejando ψ_{65i} :

$$\psi_{65i} = \arctan\left(-\frac{c_{54i} - Z_i}{X_i}\right) \quad (2.20)$$

Donde:

$$\begin{aligned} X_i &= -x_{32i} - s\beta_{21i}(z_p + a_{1312i}s(\gamma_{1413i} - \phi_p)s\theta_p + a_{1312i}c(\gamma_{1413i} - \phi_p)c\theta_p s\psi_p) \\ &\quad + c\beta_{21i}(c\gamma_{10i}(x_p - a_{1312i}c(\gamma_{1413i} - \phi_p)c\psi_p) \\ &\quad + s\gamma_{10i}(y_p + a_{1312i}s(\gamma_{1413i} - \phi_p)c\theta_p - a_{1312i}c(\gamma_{1413i} - \phi_p)s\theta_p s\psi_p)) \end{aligned} \quad (2.21)$$

$$\begin{aligned} Z_i &= s\beta_{21i}(c\gamma_{10i}(x_p - a_{1312i}c(\gamma_{1413i} - \phi_p)c\psi_p) + (y_p + a_{1312i}s(\gamma_{1413i} - \phi_p)c\theta_p)s\gamma_{10i}) + c\beta_{21i}(z_p \\ &\quad + a_{1312i}s(\gamma_{1413i} - \phi_p)s\theta_p) + a_{1312i}c(\gamma_{1413i} - \phi_p)(c\beta_{21i}c\theta_p - s\beta_{21i}s\gamma_{10i}s\theta_p)s\psi_p \end{aligned}$$

2.4.3 Solución del ángulo ϕ_{76i}

Para el cálculo de ésta variable, se partirá de la ec. 2.18, donde en este caso, la única incógnita es ϕ_{76i} , ya que ψ_{65i} se calculó en la sección anterior. Para resolver el ángulo ϕ_{76i} se toman las componentes 1 y 2 de cada lado de la ecuación. Posteriormente, se despejan $\sin(\phi_{76i})$ y $\cos(\phi_{76i})$, y empleando la función tangente se obtiene:

$$\tan \phi_{76i} = \frac{s\phi_{76i}}{c\phi_{76i}} = \frac{Y_i c\psi_{65i}}{X_i} \quad (2.22)$$

Despejando ϕ_{76i} :

$$\phi_{76i} = \arctan\left(\frac{Y_i c\psi_{65i}}{X_i}\right) \quad (2.23)$$

Donde X_i se encuentra en las ecuaciones 2.21 y:

$$Y_i = -b_{43i} + (-x_p + a_{1312i}c(\gamma_{1413i} - \phi_p)c\psi_p)s\gamma_{10i} + c\gamma_{10i}(\gamma_p + a_{1312i}s(\gamma_{1413i} - \phi_p)c\theta_p - a_{1312i}c(\gamma_{1413i} - \phi_p)s\theta_p s\psi_p) \quad (2.24)$$

2.4.4 Solución del ángulo ϕ_{1110i}

Los ángulos ϕ_{98i} , ψ_{109i} y ϕ_{1110i} conforman las juntas esféricas del sistema. Dichos ángulos se obtienen mediante una formulación de lazos matriciales, es decir, por medio de giros y desplazamientos definidos por transformaciones homogéneas, se generan lazos que partan del sistema de referencia inercial o absoluto y terminen en un sistema relativo deseado.

Para el cálculo de ϕ_{1110i} se partirá de la ec. matricial 2.2.

$$\mathbf{T}_{02i}\mathbf{T}_{24i}\mathbf{T}_{47i}\mathbf{T}_{711i}\mathbf{T}_{1114i} = \mathbf{T}_p \quad (2.2)$$

Donde las transformaciones \mathbf{T}_{02i} , \mathbf{T}_{24i} , \mathbf{T}_{47i} y \mathbf{T}_{1114i} son conocidas, ya que además de contener distancias y ángulos constantes, también contiene el desplazamiento x_{32i} y los ángulos ψ_{65i} y ϕ_{76i} , los cuales se calcularon en las secciones anteriores y son todos ellos variables. Por lo tanto, para poder calcular los ángulos de la junta esférica, despejamos, dejando de lado izquierdo la transformación \mathbf{T}_{711i} , la cual contiene los ángulos ϕ_{98i} , ψ_{109i} y ϕ_{1110i} :

$$\mathbf{T}_{711i} = \mathbf{T}_{47i}^{-1} \mathbf{T}_{24i}^{-1} \mathbf{T}_{02i}^{-1} \mathbf{T}_p \mathbf{T}_{1114i}^{-1} \quad (2.25)$$

Renombrando el lado derecho de la ecuación 2.25, se tiene:

$$\mathbf{T}_{711i} = \mathbf{T}_{ai} \quad (2.26)$$

Donde:

$$\mathbf{T}_{711i} = \begin{bmatrix} c\phi_{98i}c\phi_{1110i}c\psi_{109i} - s\phi_{98i}s\phi_{1110i} & -c\phi_{1110i}s\phi_{98i} - c\phi_{98i}c\psi_{109i}s\phi_{1110i} & c\phi_{98i}s\psi_{109i} & a_{87i} \\ c\phi_{1110i}c\psi_{109i}s\phi_{98i} + c\phi_{98i}s\phi_{1110i} & c\phi_{98i}c\phi_{1110i} - c\psi_{109i}s\phi_{98i}s\phi_{1110i} & s\phi_{98i}s\psi_{109i} & 0 \\ -c\phi_{1110i}s\psi_{109i} & s\phi_{1110i}s\psi_{109i} & c\psi_{109i} & 0 \\ 0 & 0 & 0 & 1 \end{bmatrix}$$

$$\mathbf{T}_{ai} = \begin{bmatrix} a_{11i} & a_{12i} & a_{13i} & a_{14i} \\ a_{21i} & a_{22i} & a_{23i} & a_{24i} \\ a_{31i} & a_{32i} & a_{33i} & a_{34i} \\ 0 & 0 & 0 & 1 \end{bmatrix}$$

Para resolver el ángulo ϕ_{1110i} se toman las componentes (3.1) y (3.2) de cada lado de la ecuación 2.26. Posteriormente, se despejan $\sin(\phi_{1110i})$ y $\cos(\phi_{1110i})$, y empleando la función tangente se obtiene:

$$\tan \phi_{1110i} = \frac{s\phi_{1110i}}{c\phi_{1110i}} = \frac{a_{32i}}{-a_{31i}} \quad (2.27)$$

Despejando ϕ_{1110i} :

$$\phi_{1110i} = \arctan\left(\frac{a_{32i}}{-a_{31i}}\right) \quad (2.28)$$

Donde:

$$\begin{aligned} a_{31i} &= c\phi_p \left(c(\gamma_{1211i} + \gamma_{1413i}) s(\beta_{21i} + \psi_{65i}) c\gamma_{10i} c\psi_p \right. \\ &\quad \left. - s(\gamma_{1211i} + \gamma_{1413i}) (s(\beta_{21i} + \psi_{65i}) c\theta_p s\gamma_{10i} + c(\beta_{21i} + \psi_{65i}) s\theta_p) \right) \\ &\quad + s(\gamma_{1211i} + \gamma_{1413i}) s(\beta_{21i} + \psi_{65i}) c\gamma_{10i} c\psi_p s\phi_p \\ &\quad + c(\gamma_{1211i} + \gamma_{1413i}) (s(\beta_{21i} + \psi_{65i}) c\theta_p s\gamma_{10i} + c(\beta_{21i} + \psi_{65i}) s\theta_p) s\phi_p \\ &\quad + c(\gamma_{1211i} + \gamma_{1413i} - \phi_p) (-c(\beta_{21i} + \psi_{65i}) c\theta_p + s(\beta_{21i} + \psi_{65i}) s\gamma_{10i} s\theta_p) s\psi_p \\ a_{32i} &= c(\gamma_{1211i} + \gamma_{1413i}) (c(\beta_{21i} + \psi_{65i}) c\phi_p s\theta_p + s(\beta_{21i} + \psi_{65i}) (c\theta_p c\phi_p s\gamma_{10i} - c\gamma_{10i} c\psi_p s\phi_p)) \\ &\quad + s(\gamma_{1211i} + \gamma_{1413i}) (c(\beta_{21i} + \psi_{65i}) s\theta_p s\phi_p + s(\beta_{21i} + \psi_{65i}) (c\gamma_{10i} c\phi_p c\psi_p + c\theta_p s\gamma_{10i} s\phi_p)) \\ &\quad + s(\gamma_{1211i} + \gamma_{1413i} - \phi_p) (-c(\beta_{21i} + \psi_{65i}) c\theta_p + s(\beta_{21i} + \psi_{65i}) s\gamma_{10i} s\theta_p) s\psi_p \end{aligned} \quad (2.29)$$

2.4.5 Solución del ángulo ψ_{109i}

Para el cálculo de ésta variable, se partirá de la ec. 2.26, donde en éste caso, la única incógnita es ψ_{109i} , ya que ϕ_{1110i} se calculó en la sección anterior. Para resolver el ángulo ψ_{109i} se toman las componentes (3.2) y (3.3) de cada lado de la ecuación. Posteriormente, se despejan $\sin(\psi_{109i})$ y $\cos(\psi_{109i})$, y empleando la función tangente se obtiene:

$$\tan \psi_{109i} = \frac{s\psi_{109i}}{c\psi_{109i}} = \frac{a_{32i} \csc \phi_{1110i}}{a_{33i}} \quad (2.30)$$

Despejando ψ_{109i} :

$$\psi_{109i} = \arctan\left(\frac{a_{32i} \csc \phi_{1110i}}{a_{33i}}\right) \quad (2.31)$$

Donde a_{32i} se encuentra en las ecuaciones 2.29 y:

$$a_{33i} = c(\beta_{21i} + \psi_{65i})c\theta_p c\psi_p + s(\beta_{21i} + \psi_{65i})(-c\psi_p s\gamma_{10i} s\theta_p + c\gamma_{10i} s\psi_p) \quad (2.32)$$

2.4.6 Solución del ángulo ϕ_{98i}

Para resolver el ángulo ϕ_{98i} , se trabajará con la ec. 2.26, donde en éste caso, la única incógnita es ϕ_{98i} , ya que ϕ_{1110i} y ψ_{109i} se calcularon en las últimas dos secciones anteriores. Para resolver el ángulo ϕ_{98i} se toman las componentes (1,1) y (1,2) de cada lado de la ecuación. Posteriormente, se despejan $\sin(\phi_{98i})$ y $\cos(\phi_{98i})$, y empleando la función tangente se obtiene.

$$\tan \phi_{98i} = \frac{s\phi_{98i}}{c\phi_{98i}} = \frac{c\psi_{109i}(-a_{12i} c\phi_{1110i} - a_{11i} s\phi_{1110i})}{a_{11i} c\phi_{1110i} - a_{12i} s\phi_{1110i}} \quad (2.33)$$

Despejando ϕ_{98i} :

$$\phi_{98i} = \arctan\left(\frac{c\psi_{109i}(-a_{12i} c\phi_{1110i} - a_{11i} s\phi_{1110i})}{a_{11i} c\phi_{1110i} - a_{12i} s\phi_{1110i}}\right) \quad (2.34)$$

Donde:

$$\begin{aligned} a_{11i} = & -c(\beta_{21i} + \psi_{65i})s(\gamma_{1211i} + \gamma_{1413i} - \phi_p)c\theta_p c\phi_{76i} s\gamma_{10i} \\ & + s(\gamma_{1211i} + \gamma_{1413i})s(\beta_{21i} + \psi_{65i})c\phi_{76i} c\phi_p s\theta_p - s(\gamma_{1211i} + \gamma_{1413i})c\psi_p s\gamma_{10i} s\phi_{76i} s\phi_p \\ & - c(\gamma_{1211i} + \gamma_{1413i})(c\phi_p c\psi_p s\gamma_{10i} s\phi_{76i} + s(\beta_{21i} + \psi_{65i})c\phi_{76i} s\theta_p s\phi_p) + c(\gamma_{1211i} + \gamma_{1413i} \\ & - \phi_p)c\phi_{76i}(s(\beta_{21i} + \psi_{65i})c\theta_p + c(\beta_{21i} + \psi_{65i})s\gamma_{10i} s\theta_p)s\psi_p + c\gamma_{10i}(-s(\gamma_{1211i} + \gamma_{1413i} \\ & - \phi_p)c\theta_p s\phi_{76i} + c(\gamma_{1211i} + \gamma_{1413i} - \phi_p)(c(\beta_{21i} + \psi_{65i})c\phi_{76i} c\psi_p + s\theta_p s\phi_{76i} s\psi_p)) \end{aligned} \quad (2.35)$$

$$\begin{aligned} a_{12i} = & s(\gamma_{1211i} + \gamma_{1413i})(c\phi_p c\psi_p(c(\beta_{21i} + \psi_{65i})c\gamma_{10i} c\phi_{76i} - s\gamma_{10i} s\phi_{76i}) + s(\beta_{21i} \\ & + \psi_{65i})c\phi_{76i}(-s\theta_p s\phi_p + c\theta_p c\phi_p s\psi_p) + (c(\beta_{21i} + \psi_{65i})c\phi_{76i} s\gamma_{10i} + c\gamma_{10i} s\phi_{76i})(c\theta_p s\phi_p \\ & + c\phi_p s\theta_p s\psi_p)) + c(\gamma_{1211i} + \gamma_{1413i})(c\psi_p(-c(\beta_{21i} + \psi_{65i})c\gamma_{10i} c\phi_{76i} + s\gamma_{10i} s\phi_{76i})s\phi_p - s(\beta_{21i} \\ & + \psi_{65i})c\phi_{76i}(c\phi_p s\theta_p + c\theta_p s\phi_p s\psi_p) + (c(\beta_{21i} + \psi_{65i})c\phi_{76i} s\gamma_{10i} + c\gamma_{10i} s\phi_{76i})(c\theta_p c\phi_p \\ & - s\theta_p s\phi_p s\psi_p)) \end{aligned} \quad (2.36)$$

2.5. Cálculo de la Velocidad

En el problema cinemático inverso de la velocidad, se tiene que, dada la velocidad $(\dot{x}_p, \dot{y}_p, \dot{z}_p, \dot{\theta}_p, \dot{\psi}_p, \dot{\phi}_p)$ del plato móvil, hallar la velocidad de las variables $(\dot{x}_{32i}, \dot{\psi}_{65i}, \dot{\phi}_{76i}, \dot{\phi}_{98i}, \dot{\psi}_{109i}, \dot{\phi}_{1110i})$ que se encuentran en las juntas del robot.

La velocidad de un punto o un cuerpo rígido que experimenta movimiento, puede ser obtenida por la derivada respecto al tiempo de su función de posición. Se asume en ésta sección que la posición y orientación de los cuerpos son totalmente conocidas, ya que son resultado del análisis de la posición. Por lo tanto, con base en las ecuaciones obtenidas en la sección anterior, se obtendrá la velocidad al derivar con respecto al tiempo para cada una de ellas.

2.5.1 Velocidad del desplazamiento x_{32i}

Tomando la ecuación 2.13 y derivando con respecto al tiempo, obtenemos:

$$A_{1i}x_{32i}^2 + B_{1i}x_{32i} + (D_{1i} - a_{87i}^2) = 0 \quad (2.13)$$

$$\dot{A}_{1i}x_{32i}^2 + \dot{B}_{1i}x_{32i} + \dot{D}_{1i} + B_{1i}\dot{x}_{32i} + 2A_{1i}x_{32i}\dot{x}_{32i} = 0 \quad (2.37)$$

Despejando x_{32i} y simplificando, se tiene:

$$\dot{x}_{32i} = \frac{-\dot{A}_{1i}x_{32i}^2 - \dot{B}_{1i}x_{32i} - \dot{D}_{1i}}{B_{1i} + 2A_{1i}x_{32i}} \quad (2.38)$$

Donde A_{1i} , B_{1i} y D_{1i} se encuentran en el análisis de posición, y además:

$$\begin{aligned} \dot{A}_{1i} &= 0 \\ \dot{B}_{1i} &= 2(s\beta_{21i}(\dot{z}_p - a_{1312i}c(\gamma_{1413i} - \phi_p)s\theta_p(\dot{\phi}_p + \dot{\theta}_p s\psi_p) + a_{1312i}c\theta_p(\dot{\psi}_p c(\gamma_{1413i} - \phi_p)c\psi_p + s(\gamma_{1413i} \\ &\quad - \phi_p)(\dot{\theta}_p + \dot{\phi}_p s\psi_p))) + c\beta_{21i}(-c\gamma_{10i}(\dot{x}_p - a_{1312i}\dot{\phi}_p s(\gamma_{1413i} - \phi_p)c\psi_p + a_{1312i}\dot{\psi}_p c(\gamma_{1413i} \\ &\quad - \phi_p)s\psi_p) + s\gamma_{10i}(-\dot{y}_p + a_{1312i}c(\gamma_{1413i} - \phi_p)c\theta_p(\dot{\phi}_p + \dot{\theta}_p s\psi_p) + a_{1312i}s\theta_p(\dot{\psi}_p c(\gamma_{1413i} \\ &\quad - \phi_p)c\psi_p + s(\gamma_{1413i} - \phi_p)(\dot{\theta}_p + \dot{\phi}_p s\psi_p)))) \end{aligned} \quad (2.39)$$

$$\begin{aligned} \dot{D}_{1i} &= 2((-c_{54i} + c\gamma_{10i}(x_p - a_{1312i}c(\gamma_{1413i} - \phi_p)c\psi_p)s\beta_{21i} + (y_p + a_{1312i}s(\gamma_{1413i} \\ &\quad - \phi_p)c\theta_p)s\beta_{21i}s\gamma_{10i} + c\beta_{21i}(z_p + a_{1312i}s(\gamma_{1413i} - \phi_p)s\theta_p) + a_{1312i}c(\gamma_{1413i} - \phi_p)(c\beta_{21i}c\theta_p \\ &\quad - s\beta_{21i}s\gamma_{10i}s\theta_p)s\psi_p)(s\beta_{21i}(\dot{x}_p c\gamma_{10i} + \dot{y}_p s\gamma_{10i}) + c\beta_{21i}(\dot{z}_p - a_{1312i}c(\gamma_{1413i} - \phi_p)s\theta_p(\dot{\phi}_p \\ &\quad + \dot{\theta}_p s\psi_p) + a_{1312i}c\theta_p(\dot{\psi}_p c(\gamma_{1413i} - \phi_p)c\psi_p + s(\gamma_{1413i} - \phi_p)(\dot{\theta}_p + \dot{\phi}_p s\psi_p))) \\ &\quad - a_{1312i}s\beta_{21i}(c(\gamma_{1413i} - \phi_p)c\theta_p s\gamma_{10i}(\dot{\phi}_p + \dot{\theta}_p s\psi_p) + \dot{\psi}_p c(\gamma_{1413i} - \phi_p)(c\psi_p s\gamma_{10i}s\theta_p \\ &\quad - c\gamma_{10i}s\psi_p) + s(\gamma_{1413i} - \phi_p)(\dot{\phi}_p c\gamma_{10i}c\psi_p + s\gamma_{10i}s\theta_p(\dot{\theta}_p + \dot{\phi}_p s\psi_p)))) + (-b_{43i} + (-x_p \\ &\quad + a_{1312i}c(\gamma_{1413i} - \phi_p)c\psi_p)s\gamma_{10i} + c\gamma_{10i}(y_p + a_{1312i}s(\gamma_{1413i} - \phi_p)c\theta_p - a_{1312i}c(\gamma_{1413i} \\ &\quad - \phi_p)s\theta_p s\psi_p))(-s\gamma_{10i}(\dot{x}_p - a_{1312i}\dot{\phi}_p s(\gamma_{1413i} - \phi_p)c\psi_p + a_{1312i}\dot{\psi}_p c(\gamma_{1413i} - \phi_p)s\psi_p) \\ &\quad + c\gamma_{10i}(\dot{y}_p - a_{1312i}(c(\gamma_{1413i} - \phi_p)c\theta_p(\dot{\phi}_p + \dot{\theta}_p s\psi_p) + s\theta_p(\dot{\psi}_p c(\gamma_{1413i} - \phi_p)c\psi_p + s(\gamma_{1413i} \\ &\quad - \phi_p)(\dot{\theta}_p + \dot{\phi}_p s\psi_p)))) + (s\beta_{21i}(z_p + a_{1312i}s(\gamma_{1413i} - \phi_p)s\theta_p + a_{1312i}c(\gamma_{1413i} - \phi_p)c\theta_p s\psi_p) \\ &\quad - c\beta_{21i}(c\gamma_{10i}(x_p - a_{1312i}c(\gamma_{1413i} - \phi_p)c\psi_p) + s\gamma_{10i}(y_p + a_{1312i}s(\gamma_{1413i} - \phi_p)c\theta_p \\ &\quad - a_{1312i}c(\gamma_{1413i} - \phi_p)s\theta_p s\psi_p)))(s\beta_{21i}(\dot{z}_p - a_{1312i}c(\gamma_{1413i} - \phi_p)s\theta_p(\dot{\phi}_p + \dot{\theta}_p s\psi_p) \\ &\quad + a_{1312i}c\theta_p(\dot{\psi}_p c(\gamma_{1413i} - \phi_p)c\psi_p + s(\gamma_{1413i} - \phi_p)(\dot{\theta}_p + \dot{\phi}_p s\psi_p))) + c\beta_{21i}(-c\gamma_{10i}(\dot{x}_p \\ &\quad - a_{1312i}\dot{\phi}_p s(\gamma_{1413i} - \phi_p)c\psi_p + a_{1312i}\dot{\psi}_p c(\gamma_{1413i} - \phi_p)s\psi_p) + s\gamma_{10i}(-\dot{y}_p + a_{1312i}c(\gamma_{1413i} \\ &\quad - \phi_p)c\theta_p(\dot{\phi}_p + \dot{\theta}_p s\psi_p) + a_{1312i}s\theta_p(\dot{\psi}_p c(\gamma_{1413i} - \phi_p)c\psi_p + s(\gamma_{1413i} - \phi_p)(\dot{\theta}_p + \dot{\phi}_p s\psi_p)))) \end{aligned} \quad (2.40)$$

Sustituyendo las ecuaciones 2.14, 2.39 y 2.40 en la ecuación 2.38, para después agrupar en $\dot{x}_p, \dot{y}_p, \dot{z}_p, \dot{\theta}_p, \dot{\psi}_p, \dot{\phi}_p$, se tiene:

$$\dot{x}_{32i} = \frac{1}{V_{1i}} (V_{2i}\dot{x}_p + V_{3i}\dot{y}_p + V_{4i}\dot{z}_p + V_{5i}\dot{\theta}_p + V_{6i}\dot{\psi}_p + V_{7i}\dot{\phi}_p) \quad (2.41)$$

Donde los coeficientes son:

$$\begin{aligned} V_{1i} &= B_{1i} + 2A_{1i} + x_{32i} \\ V_{2i} &= 2(-x_p + x_{32i}c\beta_{21i}c\gamma_{10i} + a_{1312i}c(\gamma_{1413i} - \phi_p)c\psi_p + c_{54i}c\gamma_{10i}s\beta_{21i} - b_{43i}s\gamma_{10i}) \\ V_{3i} &= 2(-y_p + b_{43i}c\gamma_{10i} - a_{1312i}s(\gamma_{1413i} - \phi_p)c\theta_p + x_{32i}c\beta_{21i}s\gamma_{10i} + c_{54i}s\beta_{21i}s\gamma_{10i} \\ &\quad + a_{1312i}c(\gamma_{1413i} - \phi_p)s\theta_p s\psi_p) \\ V_{4i} &= -2(z_p - c_{54i}c\beta_{21i} + x_{32i}s\beta_{21i} + a_{1312i}s(\gamma_{1413i} - \phi_p)s\theta_p + a_{1312i}c(\gamma_{1413i} - \phi_p)c\theta_p s\psi_p) \\ V_{5i} &= -2a_{1312i}s(\gamma_{1413i} - \phi_p)(c\theta_p(z_p - c_{54i}c\beta_{21i} + x_{32i}s\beta_{21i}) \\ &\quad + (-y_p + b_{43i}c\gamma_{10i} + x_{32i}c\beta_{21i}s\gamma_{10i} + c_{54i}s\beta_{21i}s\gamma_{10i})s\theta_p) \\ &\quad + 2a_{1312i}c(\gamma_{1413i} - \phi_p)(c\theta_p(y_p - b_{43i}c\gamma_{10i} - (x_{32i}c\beta_{21i} + c_{54i}s\beta_{21i})s\gamma_{10i}) \\ &\quad + (z_p - c_{54i}c\beta_{21i} + x_{32i}s\beta_{21i})s\theta_p)s\psi_p \\ V_{6i} &= -2a_{1312i}c(\gamma_{1413i} - \phi_p)(c\theta_p c\psi_p(z_p - c_{54i}c\beta_{21i} + x_{32i}s\beta_{21i}) + c\psi_p(-y_p + b_{43i}c\gamma_{10i} \\ &\quad + x_{32i}c\beta_{21i}s\gamma_{10i} + c_{54i}s\beta_{21i}s\gamma_{10i})s\theta_p + (x_p - c\gamma_{10i}(x_{32i}c\beta_{21i} + c_{54i}s\beta_{21i}) + b_{43i}s\gamma_{10i})s\psi_p) \\ V_{7i} &= 2a_{1312i}(c\phi_p c\psi_p(x_p - c\gamma_{10i}(x_{32i}c\beta_{21i} + c_{54i}s\beta_{21i}) + b_{43i}s\gamma_{10i})s\gamma_{1413i} + s\gamma_{1413i}(c\theta_p(y_p \\ &\quad - b_{43i}c\gamma_{10i} - (x_{32i}c\beta_{21i} + c_{54i}s\beta_{21i})s\gamma_{10i}) + (z_p - c_{54i}c\beta_{21i} + x_{32i}s\beta_{21i})s\theta_p)s\phi_p \\ &\quad + c\gamma_{1413i}(c\theta_p c\phi_p(y_p - b_{43i}c\gamma_{10i} - (x_{32i}c\beta_{21i} + c_{54i}s\beta_{21i})s\gamma_{10i}) + c\phi_p(z_p - c_{54i}c\beta_{21i} \\ &\quad + x_{32i}s\beta_{21i})s\theta_p + c\psi_p(-x_p + x_{32i}c\beta_{21i}c\gamma_{10i} + c_{54i}c\gamma_{10i}s\beta_{21i} - b_{43i}s\gamma_{10i})s\phi_p) - s(\gamma_{1413i} \\ &\quad - \phi_p)(c\theta_p(z_p - c_{54i}c\beta_{21i} + x_{32i}s\beta_{21i}) + (-y_p + b_{43i}c\gamma_{10i} + x_{32i}c\beta_{21i}s\gamma_{10i} \\ &\quad + c_{54i}s\beta_{21i}s\gamma_{10i})s\theta_p)s\psi_p) \end{aligned} \quad (2.42)$$

2.5.2 Velocidad del ángulo ψ_{65i}

De la ecuación 2.19 se tiene:

$$\tan(\psi_{65i}) = \frac{s\psi_{65i}}{c\psi_{65i}} = -\frac{c_{54i} - Z_i}{X_i} \quad (2.19)$$

Derivando ésta última expresión:

$$\dot{\psi}_{65i} \sec^2(\psi_{65i}) = \frac{\dot{Z}_i}{X_i} + \frac{\dot{X}_i(c_{54i} - Z_i)}{X_i^2} \quad (2.43)$$

Despejando $\dot{\psi}_{65i}$ de la ecuación 2.43:

$$\dot{\psi}_{65i} = \frac{(c_{54i}\dot{X}_i + \dot{Z}_i X_i - \dot{X}_i Z_i) \cos^2(\psi_{65i})}{X_i^2} \quad (2.44)$$

Derivando las ecuaciones 2.21 para obtener (\dot{X}_i, \dot{Z}_i) , sustituirlas en 2.44, simplificando y agrupando, tenemos:

$$\dot{\psi}_{65i} = \frac{1}{V_{8i}} (V_{9i}\dot{x}_p + V_{10i}\dot{y}_p + V_{11i}\dot{z}_p + V_{12i}\dot{\theta}_p + V_{13i}\dot{\psi}_p + V_{14i}\dot{\phi}_p + V_{15i}\dot{x}_{32i}) \quad (2.45)$$

Los términos de la ecuación anterior se muestran en el apéndice B. Finalmente, sustituyendo la ec. 2.41 en 2.45 y agrupando:

$$\dot{\psi}_{65i} = \frac{1}{V_{8i}} (E_{1i}\dot{x}_p + E_{2i}\dot{y}_p + E_{3i}\dot{z}_p + E_{4i}\dot{\theta}_p + E_{5i}\dot{\psi}_p + E_{6i}\dot{\phi}_p) \quad (2.46)$$

Donde:

$$\begin{aligned} E_{1i} &= V_{9i} + \frac{V_{15i}V_{2i}}{V_{1i}} & E_{4i} &= V_{12i} + \frac{V_{15i}V_{5i}}{V_{1i}} \\ E_{2i} &= V_{10i} + \frac{V_{15i}V_{3i}}{V_{1i}} & E_{5i} &= V_{13i} + \frac{V_{15i}V_{6i}}{V_{1i}} \\ E_{3i} &= V_{11i} + \frac{V_{15i}V_{4i}}{V_{1i}} & E_{6i} &= V_{14i} + \frac{V_{15i}V_{7i}}{V_{1i}} \end{aligned}$$

2.5.3 Velocidad del ángulo ϕ_{76i}

De la ecuación 2.22 se tiene:

$$\tan \phi_{76i} = \frac{s\phi_{76i}}{c\phi_{76i}} = \frac{Y_i c\psi_{65i}}{X_i} \quad (2.22)$$

Derivando ésta última expresión:

$$\dot{\phi}_{76i} \sec^2(\phi_{76i}) = \frac{\dot{Y}_i c\psi_{65i}}{X_i} - \frac{\dot{\psi}_{65i} Y_i s\psi_{65i}}{X_i} - \frac{\dot{X}_i Y_i c\psi_{65i}}{X_i^2} \quad (2.47)$$

Despejando $\dot{\phi}_{76i}$ de la ecuación 2.46:

$$\dot{\phi}_{76i} = \frac{\cos^2(\phi_{76i}) \left((\dot{Y}_i X_i - \dot{X}_i Y_i) c\psi_{65i} - \dot{\psi}_{65i} X_i Y_i s\psi_{65i} \right)}{X_i^2} \quad (2.48)$$

Derivando las ecuaciones 2.21 y 2.24 para obtener (\dot{X}_i, \dot{Y}_i) , sustituirlas en 2.47, simplificando y agrupando, tenemos:

$$\dot{\phi}_{76i} = \frac{1}{V_{16i}} (V_{17i}\dot{x}_p + V_{18i}\dot{y}_p + V_{19i}\dot{z}_p + V_{20i}\dot{\theta}_p + V_{21i}\dot{\psi}_p + V_{22i}\dot{\phi}_p + V_{23i}\dot{x}_{32i} + V_{24i}\dot{\psi}_{65i}) \quad (2.49)$$

Los términos de la ecuación anterior se muestran en el apéndice B. Finalmente, sustituyendo la ec. 2.41 y 2.46 en 2.49 y agrupando:

$$\dot{\phi}_{76i} = \frac{1}{V_{16i}} (E_{7i}\dot{x}_p + E_{8i}\dot{y}_p + E_{9i}\dot{z}_p + E_{10i}\dot{\theta}_p + E_{11i}\dot{\psi}_p + E_{12i}\dot{\phi}_p) \quad (2.50)$$

Donde:

$$\begin{aligned} E_{7i} &= V_{17i} + \frac{V_{23i}V_{2i}}{V_{1i}} + \frac{E_{1i}V_{24i}}{V_{8i}} & E_{10i} &= V_{20i} + \frac{V_{23i}V_{5i}}{V_{1i}} + \frac{E_{4i}V_{24i}}{V_{8i}} \\ E_{8i} &= V_{18i} + \frac{V_{23i}V_{3i}}{V_{1i}} + \frac{E_{2i}V_{24i}}{V_{8i}} & E_{11i} &= V_{21i} + \frac{V_{23i}V_{6i}}{V_{1i}} + \frac{E_{5i}V_{24i}}{V_{8i}} \\ E_{9i} &= V_{19i} + \frac{V_{23i}V_{4i}}{V_{1i}} + \frac{E_{3i}V_{24i}}{V_{8i}} & E_{12i} &= V_{22i} + \frac{V_{23i}V_{7i}}{V_{1i}} + \frac{E_{6i}V_{24i}}{V_{8i}} \end{aligned}$$

2.5.4 Velocidad del ángulo ϕ_{1110i}

De la ecuación 2.27 se tiene:

$$\tan \phi_{1110i} = \frac{s\phi_{1110i}}{c\phi_{1110i}} = \frac{a_{32i}}{-a_{31i}} \quad (2.27)$$

Derivando ésta última expresión:

$$\dot{a}_{32i} + a_{31i}\dot{\phi}_{1110i}\sec^2(\phi_{1110i}) = \frac{a_{32i}\dot{a}_{31i}}{a_{31i}} \quad (2.51)$$

Despejando $\dot{\phi}_{1110i}$ de la ecuación 2.51:

$$\dot{\phi}_{1110i} = \frac{(a_{32i}\dot{a}_{31i} - a_{31i}\dot{a}_{32i})\cos^2(\phi_{1110i})}{a_{31i}^2} \quad (2.52)$$

Derivando las ecuaciones 2.29 para obtener $(\dot{a}_{31i}, \dot{a}_{32i})$, sustituirlas en 2.52, simplificando y agrupando, tenemos:

$$\begin{aligned} \dot{\phi}_{1110i} &= \frac{1}{V_{25i}} (V_{26i}\dot{x}_p + V_{27i}\dot{y}_p + V_{28i}\dot{z}_p + V_{29i}\dot{\theta}_p + V_{30i}\dot{\psi}_p + V_{31i}\dot{\phi}_p + V_{32i}\dot{x}_{32i} + V_{33i}\dot{\psi}_{65i} \\ &\quad + V_{34i}\dot{\phi}_{76i}) \end{aligned} \quad (2.53)$$

Los términos de la ecuación anterior se muestran en el apéndice C. Finalmente, sustituyendo la ec. 2.41, 2.46 y 2.50 en 2.53 y agrupando:

$$\dot{\phi}_{1110i} = \frac{1}{V_{25i}} (E_{13i}\dot{x}_p + E_{14i}\dot{y}_p + E_{15i}\dot{z}_p + E_{16i}\dot{\theta}_p + E_{17i}\dot{\psi}_p + E_{18i}\dot{\phi}_p) \quad (2.54)$$

Donde:

$$\begin{aligned}
 E_{13i} &= \frac{E_{1i}V_{32i}}{V_{8i}} & E_{16i} &= V_{29i} + \frac{E_{4i}V_{32i}}{V_{8i}} \\
 E_{14i} &= \frac{E_{2i}V_{32i}}{V_{8i}} & E_{17i} &= V_{30i} + \frac{E_{5i}V_{32i}}{V_{8i}} \\
 E_{15i} &= \frac{E_{3i}V_{32i}}{V_{8i}} & E_{18i} &= V_{31i} + \frac{E_{6i}V_{32i}}{V_{8i}}
 \end{aligned}$$

2.5.5 Velocidad del ángulo ψ_{109i}

De la ecuación 2.30 se tiene:

$$\tan \psi_{109i} = \frac{s\psi_{109i}}{c\psi_{109i}} = \frac{a_{32i} \csc \phi_{1110i}}{a_{33i}} \quad (2.30)$$

Derivando ésta última expresión:

$$\dot{\psi}_{109i} \sec^2(\psi_{109i}) = \frac{\dot{a}_{32i} \csc(\phi_{1110i})}{a_{33i}} - \frac{a_{32i} \dot{a}_{33i} \csc(\phi_{1110i})}{a_{33i}^2} - \frac{a_{32i} \dot{\phi}_{1110i} \cot(\phi_{1110i}) \csc(\phi_{1110i})}{a_{33i}} \quad (2.55)$$

Despejando $\dot{\psi}_{109i}$ de la ecuación 2.55:

$$\dot{\psi}_{109i} = \frac{\cos^2(\psi_{109i})(a_{33i} \dot{a}_{32i} - a_{32i} \dot{a}_{33i} - a_{32i} a_{33i} \dot{\phi}_{1110i} \cot(\phi_{1110i})) \csc(\phi_{1110i})}{a_{33i}^2} \quad (2.56)$$

Derivando las ecuaciones 2.29 y 2.32 para obtener $(\dot{a}_{32i}, \dot{a}_{33i})$, sustituirlas en 2.56, simplificando y agrupando, tenemos:

$$\dot{\psi}_{109i} = \frac{1}{V_{35i}} (V_{36i} \dot{x}_p + V_{37i} \dot{y}_p + V_{38i} \dot{z}_p + V_{39i} \dot{\theta}_p + V_{40i} \dot{\psi}_p + V_{41i} \dot{\phi}_p + V_{42i} \dot{x}_{32i} + V_{43i} \dot{\psi}_{65i} + V_{44i} \dot{\phi}_{76i} + V_{45i} \dot{\phi}_{1110i}) \quad (2.57)$$

Los términos de la ecuación anterior se muestran en el apéndice C. Finalmente, sustituyendo la ec. 2.41, 2.46, 2.50 y 2.54 en 2.57 y agrupando:

$$\dot{\psi}_{109i} = \frac{1}{V_{35i}} (E_{19i} \dot{x}_p + E_{20i} \dot{y}_p + E_{21i} \dot{z}_p + E_{22i} \dot{\theta}_p + E_{23i} \dot{\psi}_p + E_{24i} \dot{\phi}_p) \quad (2.58)$$

Donde:

$$\begin{aligned}
 E_{7i} &= \frac{E_{13i}V_{45i}}{V_{25i}} + \frac{E_{1i}V_{43i}}{V_{8i}} & E_{10i} &= V_{39i} + \frac{E_{16i}V_{45i}}{V_{25i}} + \frac{E_{4i}V_{43i}}{V_{8i}} \\
 E_{8i} &= \frac{E_{14i}V_{45i}}{V_{25i}} + \frac{E_{2i}V_{43i}}{V_{8i}} & E_{11i} &= V_{40i} + \frac{E_{17i}V_{45i}}{V_{25i}} + \frac{E_{5i}V_{43i}}{V_{8i}} \\
 E_{9i} &= \frac{E_{15i}V_{45i}}{V_{25i}} + \frac{E_{3i}V_{43i}}{V_{8i}} & E_{12i} &= V_{41i} + \frac{E_{18i}V_{45i}}{V_{25i}} + \frac{E_{6i}V_{43i}}{V_{8i}}
 \end{aligned}$$

2.5.6 Velocidad del ángulo ϕ_{98i}

De la ecuación 2.33 se tiene:

$$\tan \phi_{98i} = \frac{s\phi_{98i}}{c\phi_{98i}} = \frac{c\psi_{109i}(-a_{12i}c\phi_{1110i} - a_{11i}s\phi_{1110i})}{a_{11i}c\phi_{1110i} - a_{12i}s\phi_{1110i}} \quad (2.33)$$

Derivando ésta última expresión:

$$\begin{aligned}
 \dot{\phi}_{98i} \sec^2(\phi_{98i}) &= \frac{a_{12i}\dot{a}_{11i}\cos^2(\phi_{1110i})c\psi_{109i}}{(a_{11i}c\phi_{1110i} - a_{12i}s\phi_{1110i})^2} - \frac{a_{12i}^2\dot{\phi}_{1110i}\cos^2(\phi_{1110i})c\psi_{109i}}{(a_{11i}c\phi_{1110i} - a_{12i}s\phi_{1110i})^2} \\
 &- \frac{a_{11i}\dot{a}_{12i}\sin^2(\phi_{1110i})c\psi_{109i}}{(a_{11i}c\phi_{1110i} - a_{12i}s\phi_{1110i})^2} - \frac{a_{11i}^2\dot{\phi}_{1110i}\sin^2(\phi_{1110i})c\psi_{109i}}{(a_{11i}c\phi_{1110i} - a_{12i}s\phi_{1110i})^2} \\
 &+ \frac{a_{11i}\dot{a}_{11i}c\phi_{1110i}c\psi_{109i}s\phi_{1110i}}{(a_{11i}c\phi_{1110i} - a_{12i}s\phi_{1110i})^2} - \frac{a_{12i}\dot{a}_{12i}c\phi_{1110i}c\psi_{109i}s\phi_{1110i}}{(a_{11i}c\phi_{1110i} - a_{12i}s\phi_{1110i})^2} \\
 &- \frac{2a_{11i}a_{12i}\dot{\phi}_{1110i}c\phi_{1110i}c\psi_{109i}s\phi_{1110i}}{(a_{11i}c\phi_{1110i} - a_{12i}s\phi_{1110i})^2}
 \end{aligned} \quad (2.59)$$

Despejando $\dot{\phi}_{98i}$ de la ecuación 2.59:

$$\begin{aligned}
 \dot{\phi}_{98i} &= \frac{a_{12i}\dot{a}_{11i}\cos^2(\phi_{98i})c\psi_{109i}}{(a_{11i}c\phi_{1110i} - a_{12i}s\phi_{1110i})^2} - \frac{a_{11i}\dot{a}_{12i}\cos^2(\phi_{98i})c\psi_{109i}}{(a_{11i}c\phi_{1110i} - a_{12i}s\phi_{1110i})^2} \\
 &- \frac{a_{11i}^2\dot{\phi}_{1110i}\cos^2(\phi_{98i})c\psi_{109i}}{(a_{11i}c\phi_{1110i} - a_{12i}s\phi_{1110i})^2} - \frac{a_{12i}^2\dot{\phi}_{1110i}\cos^2(\phi_{98i})c\psi_{109i}}{(a_{11i}c\phi_{1110i} - a_{12i}s\phi_{1110i})^2} \\
 &+ \frac{a_{11i}a_{12i}\dot{\psi}_{109i}\cos^2(\phi_{98i})c(2\phi_{1110i})s\psi_{109i}}{(a_{11i}c\phi_{1110i} - a_{12i}s\phi_{1110i})^2} \\
 &+ \frac{a_{11i}^2\dot{\psi}_{109i}\cos^2(\phi_{98i})c\phi_{1110i}s\phi_{1110i}s\psi_{109i}}{(a_{11i}c\phi_{1110i} - a_{12i}s\phi_{1110i})^2} \\
 &- \frac{a_{12i}^2\dot{\psi}_{109i}\cos^2(\phi_{98i})c\phi_{1110i}s\phi_{1110i}s\psi_{109i}}{(a_{11i}c\phi_{1110i} - a_{12i}s\phi_{1110i})^2}
 \end{aligned} \quad (2.60)$$

Derivando las ecuaciones 2.35 y 2.36 para obtener $(\dot{a}_{11i}, \dot{a}_{12i})$, sustituirlas en 2.60, simplificando y agrupando, tenemos:

$$\begin{aligned} \dot{\phi}_{98i} = \frac{1}{V_{46i}} & (V_{47i}\dot{x}_p + V_{48i}\dot{y}_p + V_{49i}\dot{z}_p + V_{50i}\dot{\theta}_p + V_{51i}\dot{\psi}_p + V_{52i}\dot{\phi}_p + V_{53i}\dot{x}_{32i} + V_{54i}\dot{\psi}_{65i} + V_{55i}\dot{\phi}_{76i} \\ & + V_{56i}\dot{\phi}_{1110i} + V_{57i}\dot{\psi}_{109i}) \end{aligned} \quad (2.61)$$

Los términos de la ecuación anterior se muestran en el apéndice B. Finalmente, sustituyendo la ec. 2.41, 2.46, 2.50, 2.54 y 2.58 en 2.61 y agrupando:

$$\dot{\phi}_{98i} = \frac{1}{V_{46i}} (E_{25i}\dot{x}_p + E_{26i}\dot{y}_p + E_{27i}\dot{z}_p + E_{28i}\dot{\theta}_p + E_{29i}\dot{\psi}_p + E_{30i}\dot{\phi}_p) \quad (2.62)$$

Donde:

$$\begin{aligned} E_{25i} &= \frac{E_{7i}V_{55i}}{V_{16i}} + \frac{E_{13i}V_{56i}}{V_{25i}} + \frac{E_{19i}V_{57i}}{V_{35i}} + \frac{E_{1i}V_{54i}}{V_{8i}} \\ E_{26i} &= \frac{E_{8i}V_{55i}}{V_{16i}} + \frac{E_{14i}V_{56i}}{V_{25i}} + \frac{E_{20i}V_{57i}}{V_{35i}} + \frac{E_{2i}V_{54i}}{V_{8i}} \\ E_{27i} &= \frac{E_{9i}V_{55i}}{V_{16i}} + \frac{E_{15i}V_{56i}}{V_{25i}} + \frac{E_{21i}V_{57i}}{V_{35i}} + \frac{E_{3i}V_{54i}}{V_{8i}} \\ E_{28i} &= V_{50i} + \frac{E_{10i}V_{55i}}{V_{16i}} + \frac{E_{16i}V_{56i}}{V_{25i}} + \frac{E_{22i}V_{57i}}{V_{35i}} + \frac{E_{4i}V_{54i}}{V_{8i}} \\ E_{29i} &= V_{51i} + \frac{E_{11i}V_{55i}}{V_{16i}} + \frac{E_{17i}V_{56i}}{V_{25i}} + \frac{E_{23i}V_{57i}}{V_{35i}} + \frac{E_{5i}V_{54i}}{V_{8i}} \\ E_{30i} &= V_{52i} + \frac{E_{12i}V_{55i}}{V_{16i}} + \frac{E_{18i}V_{56i}}{V_{25i}} + \frac{E_{24i}V_{57i}}{V_{35i}} + \frac{E_{6i}V_{54i}}{V_{8i}} \end{aligned}$$

2.6. Cálculo de la Aceleración

En el problema cinemático inverso de la aceleración, se tiene que, dada la aceleración $(\ddot{x}_p, \ddot{y}_p, \ddot{z}_p, \ddot{\theta}_p, \ddot{\psi}_p, \ddot{\phi}_p)$ del plato móvil, hallar la aceleración de las variables $(\ddot{x}_{32i}, \ddot{\psi}_{65i}, \ddot{\phi}_{76i}, \ddot{\phi}_{98i}, \ddot{\psi}_{109i}, \ddot{\phi}_{1110i})$ que se encuentran en las juntas del robot.

La aceleración de un punto o un cuerpo rígido que experimenta movimiento, puede ser obtenida por la derivada respecto al tiempo de su función de velocidad. Se asume en ésta sección que la posición, orientación y velocidad de los cuerpos son totalmente conocidas, ya que son resultado del análisis de posición y velocidad. Por lo tanto, con base en las ecuaciones obtenidas en la sección anterior, se obtendrá la aceleración al derivar con respecto al tiempo para cada una de ellas.

2.6.1 Aceleración del desplazamiento x_{32i}

Tomando la ecuación X.X y obteniendo la segunda derivada con respecto al tiempo, obtenemos

$$A_{1i}x_{32i}^2 + B_{1i}x_{32i} + (D_{1i} - a_{87i}^2) = 0 \quad (2.13)$$

$$\ddot{D}_{1i} + B_{1i}\ddot{x}_{32i} + 2\dot{x}_{32i}(\dot{B}_{1i} + A_{1i}\dot{x}_{32i}) + (\ddot{B}_{1i} + 2A_{1i}\ddot{x}_{32i} + 4\dot{A}_{1i}\dot{x}_{32i})x_{32i} + \ddot{A}_{1i}x_{32i}^2 = 0 \quad (2.63)$$

Despejando \ddot{x}_{32i} y simplificando, se tiene:

$$\ddot{x}_{32i} = -\frac{\ddot{D}_{1i} + 2\dot{x}_{32i}(\dot{B}_{1i} + A_{1i}\dot{x}_{32i}) + (\ddot{B}_{1i} + 4\dot{A}_{1i}\dot{x}_{32i})x_{32i} + \ddot{A}_{1i}x_{32i}^2}{B_{1i} + 2A_{1i}x_{32i}} \quad (2.64)$$

Donde A_{1i} , B_{1i} , D_{1i} , \dot{A}_{1i} , \dot{B}_{1i} y \dot{D}_{1i} se encuentran en el análisis de posición y velocidad, además:

$$\ddot{A}_{1i} = 0$$

$$\begin{aligned} \ddot{B}_{1i} = & 2(s\beta_{21i}(\ddot{z}_p - a_{1312i}s\theta_p(c(\gamma_{1413i} - \phi_p)(\ddot{\phi}_p + 2\dot{\theta}_p\dot{\psi}_p c\psi_p + \dot{\theta}_p s\dot{\psi}_p) + s(\gamma_{1413i} - \phi_p)(2\dot{\theta}_p\dot{\phi}_p s\psi_p \\ & + \dot{\theta}_p^2 + \dot{\phi}_p^2)) + a_{1312i}c\theta_p(s(\gamma_{1413i} - \phi_p)(\dot{\theta}_p + 2\dot{\phi}_p\dot{\psi}_p c\psi_p + \dot{\phi}_p s\dot{\psi}_p) - c(\gamma_{1413i} - \phi_p)(2\dot{\theta}_p\dot{\phi}_p \\ & - \dot{\psi}_p c\psi_p + s\dot{\psi}_p(\dot{\theta}_p^2 + \dot{\phi}_p^2 + \dot{\psi}_p^2)))) - c\beta_{21i}(c\gamma_{10i}(\ddot{x}_p + a_{1312i}s(\gamma_{1413i} - \phi_p)(-\dot{\phi}_p c\psi_p \\ & + 2\dot{\phi}_p\dot{\psi}_p s\psi_p) + a_{1312i}c(\gamma_{1413i} - \phi_p)(\dot{\psi}_p s\psi_p + c\dot{\psi}_p(\dot{\phi}_p^2 + \dot{\psi}_p^2))) + s\gamma_{10i}(\ddot{y}_p - a_{1312i}c\theta_p(c(\gamma_{1413i} \\ & - \phi_p)(\dot{\phi}_p + 2\dot{\theta}_p\dot{\psi}_p c\psi_p + \dot{\theta}_p s\dot{\psi}_p) + s(\gamma_{1413i} - \phi_p)(2\dot{\theta}_p\dot{\phi}_p s\psi_p + \dot{\theta}_p^2 + \dot{\phi}_p^2)) + a_{1312i}s\theta_p(-s(\gamma_{1413i} \\ & - \phi_p)(\dot{\theta}_p + 2\dot{\phi}_p\dot{\psi}_p c\psi_p + \dot{\phi}_p s\dot{\psi}_p) + c(\gamma_{1413i} - \phi_p)(2\dot{\theta}_p\dot{\phi}_p - \dot{\psi}_p c\psi_p + s\dot{\psi}_p(\dot{\theta}_p^2 + \dot{\phi}_p^2 + \dot{\psi}_p^2)))))) \end{aligned} \quad (2.65)$$

$$\begin{aligned}
 \ddot{D}_{1i} = & 2((s\gamma_{10i}(\dot{x}_p - a_{1312i}\dot{\phi}_p s(\gamma_{1413i} - \phi_p)c\psi_p + a_{1312i}\dot{\psi}_p c(\gamma_{1413i} - \phi_p)s\psi_p) + c\gamma_{10i}(-\dot{y}_p + \\
 & a_{1312i}\dot{\theta}_p s(\gamma_{1413i} - \phi_p)s\theta_p + a_{1312i}\dot{\psi}_p c(\gamma_{1413i} - \phi_p)c\psi_p s\theta_p + a_{1312i}\dot{\phi}_p s(\gamma_{1413i} - \phi_p)s\theta_p s\psi_p + \\
 & a_{1312i}c(\gamma_{1413i} - \phi_p)c\theta_p(\phi_p + \theta_p s\psi_p))^2 + (s\beta_{21i}(c\gamma_{10i}(\dot{x}_p - a_{1312i}\dot{\phi}_p s(\gamma_{1413i} - \phi_p)c\psi_p + \\
 & a_{1312i}\dot{\psi}_p c(\gamma_{1413i} - \phi_p)s\psi_p) + s\gamma_{10i}(\dot{y}_p - a_{1312i}\dot{\theta}_p s(\gamma_{1413i} - \phi_p)s\theta_p - a_{1312i}\dot{\psi}_p c(\gamma_{1413i} - \\
 & \phi_p)c\psi_p s\theta_p - a_{1312i}\dot{\phi}_p s(\gamma_{1413i} - \phi_p)s\theta_p s\psi_p - a_{1312i}c(\gamma_{1413i} - \phi_p)c\theta_p(\phi_p + \theta_p s\psi_p))) + \\
 & c\beta_{21i}(\dot{z}_p - a_{1312i}c(\gamma_{1413i} - \phi_p)s\theta_p(\phi_p + \theta_p s\psi_p) + a_{1312i}c\theta_p(\dot{\psi}_p c(\gamma_{1413i} - \phi_p)c\psi_p + s(\gamma_{1413i} - \\
 & \phi_p)(\dot{\theta}_p + \dot{\phi}_p s\psi_p))))^2 + (c\beta_{21i}(c\gamma_{10i}(\dot{x}_p - a_{1312i}\dot{\phi}_p s(\gamma_{1413i} - \phi_p)c\psi_p + a_{1312i}\dot{\psi}_p c(\gamma_{1413i} - \\
 & \phi_p)s\psi_p) + s\gamma_{10i}(\dot{y}_p - a_{1312i}\dot{\theta}_p s(\gamma_{1413i} - \phi_p)s\theta_p - a_{1312i}\dot{\psi}_p c(\gamma_{1413i} - \phi_p)c\psi_p s\theta_p - \\
 & a_{1312i}\dot{\phi}_p s(\gamma_{1413i} - \phi_p)s\theta_p s\psi_p - a_{1312i}c(\gamma_{1413i} - \phi_p)c\theta_p(\phi_p + \theta_p s\psi_p))) - s\beta_{21i}(\dot{z}_p - \\
 & \dot{\phi}_p s\psi_p))))^2 + (-b_{43i} + (-x_p + a_{1312i}c(\gamma_{1413i} - \phi_p)c\psi_p)s\gamma_{10i} + c\gamma_{10i}(y_p + a_{1312i}s(\gamma_{1413i} - \\
 & \phi_p)c\theta_p - a_{1312i}c(\gamma_{1413i} - \phi_p)s\theta_p s\psi_p))(-s\gamma_{10i}(\ddot{x}_p - a_{1312i}\ddot{\phi}_p s(\gamma_{1413i} - \phi_p)c\psi_p + \\
 & 2a_{1312i}\dot{\phi}_p \dot{\psi}_p s(\gamma_{1413i} - \phi_p)s\psi_p + a_{1312i}c(\gamma_{1413i} - \phi_p)(\ddot{\psi}_p s\psi_p + c\psi_p(\dot{\phi}_p^2 + \dot{\psi}_p^2))) + c\gamma_{10i}(\ddot{y}_p - \\
 & a_{1312i}\ddot{\theta}_p s(\gamma_{1413i} - \phi_p)s\theta_p - 2a_{1312i}\dot{\phi}_p \dot{\psi}_p s(\gamma_{1413i} - \phi_p)c\psi_p s\theta_p - a_{1312i}\ddot{\phi}_p s(\gamma_{1413i} - \\
 & \phi_p)s\theta_p s\psi_p - a_{1312i}c\theta_p(c(\gamma_{1413i} - \phi_p)(\ddot{\phi}_p + 2\dot{\theta}_p \dot{\psi}_p c\psi_p + \ddot{\theta}_p s\psi_p) + s(\gamma_{1413i} - \phi_p)(2\dot{\theta}_p \dot{\phi}_p s\psi_p + \\
 & \ddot{\theta}_p^2 + \dot{\phi}_p^2)) + a_{1312i}c(\gamma_{1413i} - \phi_p)s\theta_p(2\dot{\theta}_p \dot{\phi}_p - \ddot{\psi}_p c\psi_p + s\psi_p(\dot{\theta}_p^2 + \dot{\phi}_p^2 + \dot{\psi}_p^2)))) + (s\beta_{21i}(z_p + \\
 & a_{1312i}s(\gamma_{1413i} - \phi_p)s\theta_p + a_{1312i}c(\gamma_{1413i} - \phi_p)c\theta_p s\psi_p) - c\beta_{21i}(c\gamma_{10i}(x_p - a_{1312i}c(\gamma_{1413i} - \\
 & \phi_p)c\psi_p) + s\gamma_{10i}(y_p + a_{1312i}s(\gamma_{1413i} - \phi_p)c\theta_p - a_{1312i}c(\gamma_{1413i} - \phi_p)s\theta_p s\psi_p)))(s\beta_{21i}(\dot{z}_p - \\
 & 2a_{1312i}\dot{\theta}_p \dot{\phi}_p s(\gamma_{1413i} - \phi_p)s\theta_p s\psi_p - a_{1312i}c(\gamma_{1413i} - \phi_p)s\theta_p(\dot{\phi}_p + 2\dot{\theta}_p \dot{\psi}_p c\psi_p + \ddot{\theta}_p s\psi_p) - \\
 & a_{1312i}s(\gamma_{1413i} - \phi_p)s\theta_p \dot{\theta}_p^2 - a_{1312i}s(\gamma_{1413i} - \phi_p)s\theta_p \dot{\phi}_p^2 + a_{1312i}c\theta_p(s(\gamma_{1413i} - \phi_p)(\dot{\theta}_p + \\
 & 2\dot{\phi}_p \dot{\psi}_p c\psi_p + \dot{\phi}_p s\psi_p) - c(\gamma_{1413i} - \phi_p)(2\dot{\theta}_p \dot{\phi}_p - \ddot{\psi}_p c\psi_p + s\psi_p(\dot{\theta}_p^2 + \dot{\phi}_p^2 + \dot{\psi}_p^2)))) - \\
 & c\beta_{21i}(c\gamma_{10i}(\ddot{x}_p - a_{1312i}\ddot{\phi}_p s(\gamma_{1413i} - \phi_p)c\psi_p + 2a_{1312i}\dot{\phi}_p \dot{\psi}_p s(\gamma_{1413i} - \phi_p)s\psi_p + a_{1312i}c(\gamma_{1413i} - \\
 & \phi_p)(\ddot{\psi}_p s\psi_p + c\psi_p(\dot{\phi}_p^2 + \dot{\psi}_p^2))) + s\gamma_{10i}(\ddot{y}_p - a_{1312i}\ddot{\theta}_p s(\gamma_{1413i} - \phi_p)s\theta_p - 2a_{1312i}\dot{\phi}_p \dot{\psi}_p s(\gamma_{1413i} - \\
 & \phi_p)c\psi_p s\theta_p - a_{1312i}\ddot{\phi}_p s(\gamma_{1413i} - \phi_p)s\theta_p s\psi_p - a_{1312i}c\theta_p(c(\gamma_{1413i} - \phi_p)(\ddot{\phi}_p + 2\dot{\theta}_p \dot{\psi}_p c\psi_p + \\
 & \ddot{\theta}_p s\psi_p) + s(\gamma_{1413i} - \phi_p)(2\dot{\theta}_p \dot{\phi}_p s\psi_p + \dot{\theta}_p^2 + \dot{\phi}_p^2)) + a_{1312i}c(\gamma_{1413i} - \phi_p)s\theta_p(2\dot{\theta}_p \dot{\phi}_p - \ddot{\psi}_p c\psi_p + \\
 & s\psi_p(\dot{\theta}_p^2 + \dot{\phi}_p^2 + \dot{\psi}_p^2)))) + (-c_{54i} + c\gamma_{10i}(x_p - a_{1312i}c(\gamma_{1413i} - \phi_p)c\psi_p)s\beta_{21i} + (y_p + \\
 & a_{1312i}s(\gamma_{1413i} - \phi_p)c\theta_p)s\beta_{21i}s\gamma_{10i} + c\beta_{21i}(z_p + a_{1312i}s(\gamma_{1413i} - \phi_p)s\theta_p) + a_{1312i}c(\gamma_{1413i} - \\
 & \phi_p)(c\beta_{21i}c\theta_p - s\beta_{21i}s\gamma_{10i}s\theta_p)s\psi_p)(c\beta_{21i}(\dot{z}_p - 2a_{1312i}\dot{\theta}_p \dot{\phi}_p s(\gamma_{1413i} - \phi_p)s\theta_p s\psi_p - \\
 & a_{1312i}c(\gamma_{1413i} - \phi_p)s\theta_p(\dot{\phi}_p + 2\dot{\theta}_p \dot{\psi}_p c\psi_p + \ddot{\theta}_p s\psi_p) - a_{1312i}s(\gamma_{1413i} - \phi_p)s\theta_p \dot{\theta}_p^2 - \\
 & a_{1312i}s(\gamma_{1413i} - \phi_p)s\theta_p \dot{\phi}_p^2 + a_{1312i}c\theta_p(s(\gamma_{1413i} - \phi_p)(\dot{\theta}_p + 2\dot{\phi}_p \dot{\psi}_p c\psi_p + \dot{\phi}_p s\psi_p) - c(\gamma_{1413i} - \\
 & \phi_p)(2\dot{\theta}_p \dot{\phi}_p - \ddot{\psi}_p c\psi_p + s\psi_p(\dot{\theta}_p^2 + \dot{\phi}_p^2 + \dot{\psi}_p^2)))) + s\beta_{21i}(c\gamma_{10i}(\ddot{x}_p - a_{1312i}\ddot{\phi}_p s(\gamma_{1413i} - \phi_p)c\psi_p + \\
 & 2a_{1312i}\dot{\phi}_p \dot{\psi}_p s(\gamma_{1413i} - \phi_p)s\psi_p + a_{1312i}c(\gamma_{1413i} - \phi_p)(\ddot{\psi}_p s\psi_p + c\psi_p(\dot{\phi}_p^2 + \dot{\psi}_p^2))) + s\gamma_{10i}(\ddot{y}_p - \\
 & a_{1312i}\ddot{\theta}_p s(\gamma_{1413i} - \phi_p)s\theta_p - 2a_{1312i}\dot{\phi}_p \dot{\psi}_p s(\gamma_{1413i} - \phi_p)c\psi_p s\theta_p - a_{1312i}\ddot{\phi}_p s(\gamma_{1413i} - \\
 & \phi_p)s\theta_p s\psi_p - a_{1312i}c\theta_p(c(\gamma_{1413i} - \phi_p)(\dot{\phi}_p + 2\dot{\theta}_p \dot{\psi}_p c\psi_p + \ddot{\theta}_p s\psi_p) + s(\gamma_{1413i} - \phi_p)(2\dot{\theta}_p \dot{\phi}_p s\psi_p + \\
 & \dot{\theta}_p^2 + \dot{\phi}_p^2)) + a_{1312i}c(\gamma_{1413i} - \phi_p)s\theta_p(2\dot{\theta}_p \dot{\phi}_p - \ddot{\psi}_p c\psi_p + s\psi_p(\dot{\theta}_p^2 + \dot{\phi}_p^2 + \dot{\psi}_p^2))))))
 \end{aligned} \tag{2.66}$$

Sustituyendo A_{1i} , B_{1i} , D_{1i} , \dot{A}_{1i} , \dot{B}_{1i} , \dot{D}_{1i} , \ddot{A}_{1i} , \ddot{B}_{1i} y \ddot{D}_{1i} , en la ecuación 2.64 para después agrupar en \ddot{x}_{32i} , $\ddot{\psi}_{65i}$, $\ddot{\phi}_{76i}$, $\ddot{\phi}_{98i}$, $\ddot{\psi}_{109i}$, $\ddot{\phi}_{1110i}$, se tiene:

$$\ddot{x}_{32i} = \frac{1}{V_{58i}} (G_{1i}\dot{x}_p + G_{2i}\dot{y}_p + G_{3i}\dot{z}_p + G_{4i}\dot{\theta}_p + G_{5i}\dot{\psi}_p + G_{6i}\dot{\phi}_p + G_{7i}) \quad (2.67)$$

Los coeficientes de la ecuación 2.67 se muestran en el apéndice C.

2.6.2 Aceleración del ángulo ψ_{65i}

Tomando la ecuación 2.19 y obteniendo la segunda derivada con respecto al tiempo, obtenemos.

$$\tan(\psi_{65i}) = \frac{s\psi_{65i}}{c\psi_{65i}} = -\frac{c_{54i} - Z_i}{X_i} \quad (2.19)$$

$$\ddot{\psi}_{65i} \sec^2(\psi_{65i}) + 2\sec^2(\psi_{65i})\dot{\psi}_{65i} \tan(\psi_{65i}) = \frac{\ddot{Z}_i}{X_i} - \frac{2\dot{X}_i\dot{Z}_i}{X_i^2} + (c_{54i} - Z_i) \left(\frac{\ddot{X}_i}{X_i^2} - \frac{2\dot{X}_i^2}{X_i^3} \right) \quad (2.68)$$

Despejando $\ddot{\psi}_{65i}$ y simplificando, se tiene:

$$\ddot{\psi}_{65i} = \frac{\ddot{Z}_i \cos^2(\psi_{65i})}{X_i} + \frac{c_{54i} \ddot{X}_i \cos^2(\psi_{65i})}{X_i^2} - \frac{2\dot{X}_i \dot{Z}_i \cos^2(\psi_{65i})}{X_i^2} - \frac{\ddot{X}_i Z_i \cos^2(\psi_{65i})}{X_i^2} - \frac{2c_{54i} \cos^2(\psi_{65i}) \dot{X}_i^2}{X_i^3} \quad (2.69)$$

$$+ \frac{2Z_i \cos^2(\psi_{65i}) \dot{X}_i^2}{X_i^3} - 2\dot{\psi}_{65i}^2 \tan(\psi_{65i})$$

Donde X_i , Z_i , \dot{X}_i y \dot{Z}_i se encuentran en el análisis de posición y velocidad. Además, derivando las ecuaciones 2.21 para obtener (\ddot{X}_i, \ddot{Z}_i) , sustituirlas en 2.69, simplificando y agrupando, tenemos:

$$\ddot{\psi}_{65i} = \frac{1}{V_{59i}} (G_{8i}\dot{x}_p + G_{9i}\dot{y}_p + G_{10i}\dot{z}_p + G_{11i}\dot{\theta}_p + G_{12i}\dot{\psi}_p + G_{13i}\dot{\phi}_p + G_{14i}) \quad (2.70)$$

Los coeficientes de la ecuación 2.71 se muestran en el apéndice C.

2.6.3 Aceleración del ángulo ϕ_{76i}

Tomando la ecuación 2.22 y obteniendo la segunda derivada con respecto al tiempo, obtenemos:

$$\tan(\phi_{76i}) = \frac{Y_i c\psi_{65i}}{X_i} \quad (2.22)$$

$$\ddot{\phi}_{76i} \sec^2(\phi_{76i}) + 2\dot{\phi}_{76i}^2 \sec^2(\phi_{76i}) \tan(\phi_{76i}) = \frac{\ddot{Y}_i c\psi_{65i}}{X_i} + 2\dot{Y}_i \left(-\frac{\dot{\psi}_{65i} s\psi_{65i}}{X_i} - \frac{\dot{X}_i c\psi_{65i}}{X_i^2} \right) + Y_i \left(\frac{2\dot{X}_i \dot{\psi}_{65i} s\psi_{65i}}{X_i^2} + c\psi_{65i} \left(-\frac{\ddot{X}_i}{X_i^2} + \frac{2\dot{X}_i^2}{X_i^3} \right) + \frac{-\ddot{\psi}_{65i} s\psi_{65i} - c\psi_{65i} \dot{\psi}_{65i}^2}{X_i} \right) \quad (2.71)$$

Despejando $\ddot{\phi}_{76i}$ y simplificando, se tiene:

$$\ddot{\phi}_{76i} = \frac{\ddot{Y}_i \cos^2(\phi_{76i}) c\psi_{65i}}{X_i} - \frac{2\dot{Y}_i \dot{\psi}_{65i} \cos^2(\phi_{76i}) s\psi_{65i}}{X_i} - \frac{\ddot{\psi}_{65i} Y_i \cos^2(\phi_{76i}) s\psi_{65i}}{X_i} - \frac{2\dot{X}_i \dot{Y}_i \cos^2(\phi_{76i}) c\psi_{65i}}{X_i^2} - \frac{\ddot{X}_i Y_i \cos^2(\phi_{76i}) c\psi_{65i}}{X_i^2} + \frac{2\dot{X}_i \dot{\psi}_{65i} Y_i \cos^2(\phi_{76i}) s\psi_{65i}}{X_i^2} + \frac{2Y_i \cos^2(\phi_{76i}) c\psi_{65i} \dot{X}_i^2}{X_i^3} - \frac{Y_i \cos^2(\phi_{76i}) c\psi_{65i} \dot{\psi}_{65i}^2}{X_i} - 2\dot{\phi}_{76i}^2 \tan(\phi_{76i}) \quad (2.72)$$

Donde X_i , Y_i , \dot{X}_i y \dot{Y}_i se encuentran en el análisis de posición y velocidad. Además, Derivando las ecuaciones 2.21 y 2.24 para obtener (\ddot{X}_i, \ddot{Y}_i) , sustituirlas en 2.72, simplificando y agrupando, tenemos:

$$\ddot{\phi}_{76i} = \frac{1}{V_{60i}} (G_{15i} \dot{x}_p + G_{16i} \dot{y}_p + G_{17i} \dot{z}_p + G_{18i} \dot{\theta}_p + G_{19i} \dot{\psi}_p + G_{20i} \dot{\phi}_p + G_{21i}) \quad (2.73)$$

Los coeficientes de la ecuación 2.73 se muestran en el apéndice C.

2.6.4 Aceleración del ángulo ϕ_{1110i}

Tomando la ecuación 2.27 y obteniendo la segunda derivada con respecto al tiempo, obtenemos:

$$\tan \phi_{1110i} = \frac{a_{32i}}{-a_{31i}} \quad (2.27)$$

$$\ddot{\phi}_{1110i} \sec^2(\phi_{1110i}) + 2\sec^2(\phi_{1110i}) \dot{\phi}_{1110i}^2 \tan(\phi_{1110i}) = \frac{2\dot{a}_{31i} \dot{a}_{32i}}{a_{31i}^2} - \frac{\ddot{a}_{32i}}{a_{31i}} + a_{32i} \left(\frac{\ddot{a}_{31i}}{a_{31i}^2} - \frac{2\dot{a}_{31i}^2}{a_{31i}^3} \right) \quad (2.74)$$

Despejando $\ddot{\phi}_{1110i}$ y simplificando, se tiene:

$$\ddot{\phi}_{1110i} = \frac{2\dot{a}_{31i} \dot{a}_{32i} \cos^2(\phi_{1110i})}{a_{31i}^2} + \frac{a_{32i} \ddot{a}_{31i} \cos^2(\phi_{1110i})}{a_{31i}^2} - \frac{\ddot{a}_{32i} \cos^2(\phi_{1110i})}{a_{31i}} - \frac{2a_{32i} \cos^2(\phi_{1110i}) \dot{a}_{31i}^2}{a_{31i}^3} - 2\dot{\phi}_{1110i}^2 \tan(\phi_{1110i}) \quad (2.75)$$

Donde a_{31i} , a_{32i} , \dot{a}_{31i} y \dot{a}_{32i} se encuentran en el análisis de posición y velocidad. Además, Derivando dos veces las ecuaciones 2.29 para obtener $(\ddot{a}_{31i}, \ddot{a}_{32i})$, sustituirlas en 2.75, simplificando y agrupando, tenemos:

$$\ddot{\phi}_{1110i} = \frac{1}{V_{61i}} (G_{22i}\dot{x}_p + G_{23i}\dot{y}_p + G_{24i}\dot{z}_p + G_{25i}\dot{\theta}_p + G_{26i}\dot{\psi}_p + G_{27i}\dot{\phi}_p + G_{28i}) \quad (2.76)$$

Los coeficientes de la ecuación 2.75 se muestran en el apéndice C.

2.6.5 Aceleración del ángulo ψ_{109i}

Tomando la ecuación 2.30 y obteniendo la segunda derivada con respecto al tiempo, obtenemos.

$$\tan(\psi_{109i}) = \frac{a_{32i} \csc(\phi_{1110i})}{a_{33i}} \quad (2.30)$$

$$\begin{aligned} \ddot{\psi}_{109i} \sec^2(\psi_{109i}) &= -2\sec^2(\psi_{109i})\dot{\psi}_{109i}^2 \tan(\psi_{109i}) + \frac{\ddot{a}_{32i} \csc(\phi_{1110i})}{a_{33i}} \\ &\quad - \frac{a_{32i}\ddot{\phi}_{1110i} \cot(\phi_{1110i}) \csc(\phi_{1110i})}{a_{33i}} - \frac{2\dot{a}_{32i}\dot{\phi}_{1110i} \cot(\phi_{1110i}) \csc(\phi_{1110i})}{a_{33i}} \\ &\quad - \frac{2\dot{a}_{32i}\dot{a}_{33i} \csc(\phi_{1110i})}{a_{33i}^2} - \frac{a_{32i}\ddot{a}_{33i} \csc(\phi_{1110i})}{a_{33i}^2} \\ &\quad + \frac{2a_{32i}\dot{a}_{33i}\dot{\phi}_{1110i} \cot(\phi_{1110i}) \csc(\phi_{1110i})}{a_{33i}^2} + \frac{2a_{32i} \csc(\phi_{1110i}) \dot{a}_{33i}^2}{a_{33i}^3} \\ &\quad + \frac{a_{32i} \cot^2(\phi_{1110i}) \csc(\phi_{1110i}) \dot{\phi}_{1110i}^2}{a_{33i}} + \frac{a_{32i} \csc^3(\phi_{1110i}) \dot{\phi}_{1110i}^2}{a_{33i}} \end{aligned} \quad (2.77)$$

Despejando $\ddot{\psi}_{109i}$ y simplificando, se tiene:

$$\begin{aligned} \ddot{\psi}_{109i} &= \frac{1}{a_{33i}^3} \left(\cos^2(\psi_{109i}) \csc(\phi_{1110i}) \left(-a_{33i}(2\dot{a}_{32i}\dot{a}_{33i} + a_{32i}\ddot{a}_{33i}) + 2a_{32i}\dot{a}_{33i}^2 + \ddot{a}_{32i}\dot{a}_{33i}^2 + \right. \right. \\ &\quad \left. \left. a_{33i} \left(a_{32i}a_{33i} \csc^2(\phi_{1110i}) \dot{\phi}_{1110i}^2 + \cot(\phi_{1110i}) (-a_{32i}a_{33i}\ddot{\phi}_{1110i} - 2a_{33i}\dot{a}_{32i}\dot{\phi}_{1110i} + \right. \right. \right. \\ &\quad \left. \left. \left. 2a_{32i}\dot{a}_{33i}\dot{\phi}_{1110i} + a_{32i}a_{33i} \cot(\phi_{1110i}) \dot{\phi}_{1110i}^2 \right) \right) - 2a_{33i}^3 \dot{\psi}_{109i}^2 \tan(\psi_{109i}) \right) \end{aligned} \quad (2.78)$$

Donde a_{32i} , \dot{a}_{32i} , \ddot{a}_{32i} y \dot{a}_{33i} se encuentran en el análisis de posición y velocidad. Además, Derivando dos veces las ecuaciones 2.29 y 2.32 para obtener $(\ddot{a}_{32i}, \ddot{a}_{33i})$, sustituirlas en 2.78, simplificando y agrupando, tenemos

$$\ddot{\psi}_{109i} = \frac{1}{V_{62i}} (G_{29i}\dot{x}_p + G_{30i}\dot{y}_p + G_{31i}\dot{z}_p + G_{32i}\dot{\theta}_p + G_{33i}\dot{\psi}_p + G_{34i}\dot{\phi}_p + G_{35i}) \quad (2.79)$$

Los coeficientes de la ecuación 2.79 se muestran en el apéndice C.

2.6.6 Aceleración del ángulo ϕ_{98i}

Tomando la ecuación 2.98 y obteniendo la segunda derivada con respecto al tiempo, obtenemos:

$$\tan(\phi_{98i}) = \frac{c\psi_{109i}(-a_{12i}c\phi_{1110i} - a_{11i}s\phi_{1110i})}{a_{11i}c\phi_{1110i} - a_{12i}s\phi_{1110i}} \quad (2.33)$$

$$\begin{aligned} (\ddot{\phi}_{98i} + 2\dot{\phi}_{98i}^2 \tan(\phi_{98i})) &= \frac{1}{(a_{11i}c\phi_{1110i} - a_{12i}s\phi_{1110i})^3} (-2(a_{11i}c\phi_{1110i} - a_{12i}s\phi_{1110i}))((- \dot{a}_{11i} \\ &+ a_{12i}\dot{\phi}_{1110i})c\phi_{1110i} + (\dot{a}_{12i} + a_{11i}\dot{\phi}_{1110i})s\phi_{1110i})(s\phi_{1110i}((\dot{a}_{11i} \\ &- a_{12i}\dot{\phi}_{1110i})c\psi_{109i} - a_{11i}\dot{\psi}_{109i}s\psi_{109i}) + c\phi_{1110i}((\dot{a}_{12i} \\ &+ a_{11i}\dot{\phi}_{1110i})c\psi_{109i} - a_{12i}\dot{\psi}_{109i}s\psi_{109i})) + c\psi_{109i}(-a_{12i}c\phi_{1110i} \\ &- a_{11i}s\phi_{1110i})(2((\dot{a}_{11i} - a_{12i}\dot{\phi}_{1110i})c\phi_{1110i} - (\dot{a}_{12i} \\ &+ a_{11i}\dot{\phi}_{1110i})s\phi_{1110i})^2 + (a_{11i}c\phi_{1110i} - a_{12i}s\phi_{1110i})(c\phi_{1110i}(-\ddot{a}_{11i} \\ &+ a_{12i}\ddot{\phi}_{1110i} + 2\dot{a}_{12i}\dot{\phi}_{1110i} + a_{11i}\dot{\phi}_{1110i}^2) + s\phi_{1110i}(\ddot{a}_{12i} \\ &+ a_{11i}\ddot{\phi}_{1110i} + 2\dot{a}_{11i}\dot{\phi}_{1110i} - a_{12i}\dot{\phi}_{1110i}^2))) + (a_{11i}c\phi_{1110i} \\ &- a_{12i}s\phi_{1110i})^2(s\phi_{1110i}((a_{11i}\dot{\psi}_{109i} + 2\dot{a}_{11i}\dot{\psi}_{109i} \\ &- 2a_{12i}\dot{\phi}_{1110i}\dot{\psi}_{109i})s\psi_{109i} + c\psi_{109i}(-\ddot{a}_{11i} + a_{12i}\ddot{\phi}_{1110i} \\ &+ 2\dot{a}_{12i}\dot{\phi}_{1110i} + a_{11i}\dot{\phi}_{1110i}^2 + a_{11i}\dot{\psi}_{109i}^2)) + c\phi_{1110i}((a_{12i}\dot{\psi}_{109i} \\ &+ 2(\dot{a}_{12i} + a_{11i}\dot{\phi}_{1110i})\dot{\psi}_{109i})s\psi_{109i} - c\psi_{109i}(\ddot{a}_{12i} + a_{11i}\ddot{\phi}_{1110i} \\ &+ 2\dot{a}_{11i}\dot{\phi}_{1110i} - a_{12i}\dot{\phi}_{1110i}^2 - a_{12i}\dot{\psi}_{109i}^2)))) \end{aligned} \quad (2.80)$$

Despejando $\ddot{\phi}_{98i}$ y simplificando, se tiene:

$$\begin{aligned} \ddot{\phi}_{98i} &= \cos^2(\phi_{98i}) \left(\frac{1}{4(a_{11i}c\phi_{1110i} - a_{12i}s\phi_{1110i})^3} (2(2a_{11i}a_{12i}\dot{\psi}_{109i}c(2\phi_{1110i}) + (a_{11i} - a_{12i})(a_{11i} \\ &+ a_{12i})\dot{\psi}_{109i}s(2\phi_{1110i}) + 4\dot{\psi}_{109i}(-a_{12i}\dot{a}_{11i} + a_{11i}(\dot{a}_{12i} + a_{11i}\dot{\phi}_{1110i}) \\ &+ \phi_{1110i}a_{12i}^2)))(a_{11i}c\phi_{1110i} - a_{12i}s\phi_{1110i})s\psi_{109i} + c\psi_{109i}(a_{11i}s(3\phi_{1110i})(a_{11i}^2 - 3a_{12i}^2)\dot{\psi}_{109i}^2 \\ &- a_{12i}c(3\phi_{1110i})(-3a_{11i}^2 + a_{12i}^2)\dot{\psi}_{109i}^2 + s\phi_{1110i}(4(a_{12i}^3\phi_{1110i} - 2a_{11i}(\dot{a}_{12i} + a_{11i}\dot{\phi}_{1110i})^2 \\ &+ a_{12i}(a_{11i}(\ddot{a}_{12i} + a_{11i}\ddot{\phi}_{1110i}) + 2\dot{a}_{11i}(\dot{a}_{12i} + 2a_{11i}\dot{\phi}_{1110i})) - a_{12i}^2(\ddot{a}_{11i} + 2a_{11i}\dot{\phi}_{1110i}^2)) \\ &+ a_{11i}(a_{11i}^2 + a_{12i}^2)\dot{\psi}_{109i}^2) + c\phi_{1110i}(-4a_{11i}(-2\dot{a}_{11i}\dot{a}_{12i} + a_{11i}(\ddot{a}_{12i} + a_{11i}\ddot{\phi}_{1110i})) \\ &- 4(a_{11i}\dot{\phi}_{1110i} - 4\dot{a}_{11i}\dot{\phi}_{1110i})a_{12i}^2 + a_{12i}^3(-8\dot{\phi}_{1110i}^2 + \dot{\psi}_{109i}^2) + a_{12i}(-8\dot{a}_{11i} + a_{11i}(4\dot{a}_{11i} \\ &- 8\dot{\phi}_{1110i}(2\dot{a}_{12i} + a_{11i}\dot{\phi}_{1110i}) + a_{11i}\dot{\psi}_{109i}^2)))) - 2\dot{\phi}_{98i} \sec^2(\phi_{98i})\tan(\phi_{98i}) \right) \end{aligned} \quad (2.81)$$

Donde a_{11i} , a_{12i} , \dot{a}_{11i} y \dot{a}_{12i} se encuentran en el análisis de posición y velocidad. Además, derivando dos veces las ecuaciones 2.35 y 2.36 para obtener $(\ddot{a}_{11i}, \ddot{a}_{12i})$, sustituirlas en 2.81, simplificando y agrupando, tenemos:

$$\ddot{\phi}_{98i} = \frac{1}{V_{63i}} (G_{36i}\dot{x}_p + G_{37i}\dot{y}_p + G_{38i}\dot{z}_p + G_{39i}\dot{\theta}_p + G_{40i}\dot{\psi}_p + G_{41i}\dot{\phi}_p + G_{42i}) \quad (2.82)$$

Los coeficientes de la ecuación 2.82 se muestran en el apéndice C.

Capítulo 3

Análisis Dinámico

Formulación Euler-Lagrange

3.1. Introducción

En éste capítulo, se considera la dinámica del robot, con el fin de poder determinar los torques aplicados por los actuadores en los eslabones de entrada para que el efector final alcance una trayectoria dada.

El método de Euler-Lagrange formula ecuaciones de movimiento usando un conjunto de coordenadas generalizadas (Spong, y otros, 1989). Esto permite eliminar todas o algunas de las fuerzas de restricción y permite manejar desplazamientos tanto desplazamientos lineales como angulares con un solo tipo de coordenadas. Con el entendimiento de la dinámica del manipulador, es posible diseñar un controlador con mejores características de ejecución que las realizadas con los típicos encontrados usando métodos heurísticos después de que el manipulador ha sido construido.

En este capítulo se empleará la siguiente notación:

- I_{ij} – Matriz de inercia del cuerpo i cadena j
- K – Energía cinética del sistema mecánico
- L – Función Lagrangiana
- M_{ij} – Matriz de elementos de masa del cuerpo i , cadena j
- q_j – Coordenada j -ésima generalizada
- \mathbf{q} – Vector de coordenadas generalizadas
- U – Energía potencial del sistema mecánico
- Q_j – Vector de fuerzas generalizadas

La función Lagrangiana es definida como la diferencia entre la energía cinética y la energía potencial de un sistema como:

$$L = K - U \quad (3.1)$$

Donde K es la energía cinética definida como:

$$K = \frac{1}{2} m \mathbf{v}^T \mathbf{v} + \boldsymbol{\omega}^T \mathbf{I} \boldsymbol{\omega} \quad (3.2)$$

Y la energía potencial como:

$$U = -m \mathbf{g}^T \mathbf{r}_G \quad (3.3)$$

La energía cinética depende de la velocidad de los eslabones del manipulador, mientras que la energía potencial depende únicamente de la localización de los eslabones. La ecuación de Lagrange de movimiento es formulada en términos de la función Lagrangiana como:

$$\frac{d}{dt} \left(\frac{\partial L}{\partial \dot{q}_j} \right) - \frac{\partial L}{\partial q_j} = Q_j \quad (3.4)$$

El término Q_j es conocido como el vector de fuerzas generalizadas y se obtendrá a partir de expresiones, que involucren los torques y las coordenadas generalizadas.

3.2. Análisis de Posición y Velocidad de Centros de Gravedad

Para el análisis del robot paralelo se tomaron en cuenta los siguientes cuerpos:

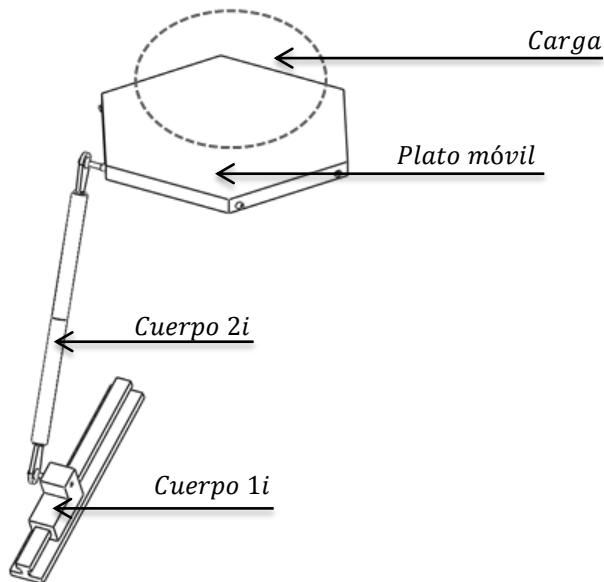

Fig. 3.1 Cuerpos del robot

Las siguientes matrices de rotación, nos representan la rotación alrededor de los ejes x, y, z respectivamente:

$$\mathbf{R}_x(\theta) = \begin{bmatrix} 1 & 0 & 0 \\ 0 & c\theta & -s\theta \\ 0 & s\theta & c\theta \end{bmatrix} \quad \mathbf{R}_y(\theta) = \begin{bmatrix} c\theta & 0 & s\theta \\ 0 & 1 & 0 \\ -s\theta & 0 & c\theta \end{bmatrix} \quad \mathbf{R}_z(\theta) = \begin{bmatrix} c\theta & -s\theta & 0 \\ s\theta & c\theta & 0 \\ 0 & 0 & 1 \end{bmatrix}$$

Se puede observar que en la ec. (3.2) aparece la velocidad de centro de gravedad y la velocidad angular de cada cuerpo., por lo que tendrán que ser formuladas a lo largo de éste sección. A continuación, se procederá a obtener los vectores de centro de gravedad definidos en la base inercial, mostrados en la figura 3.2:

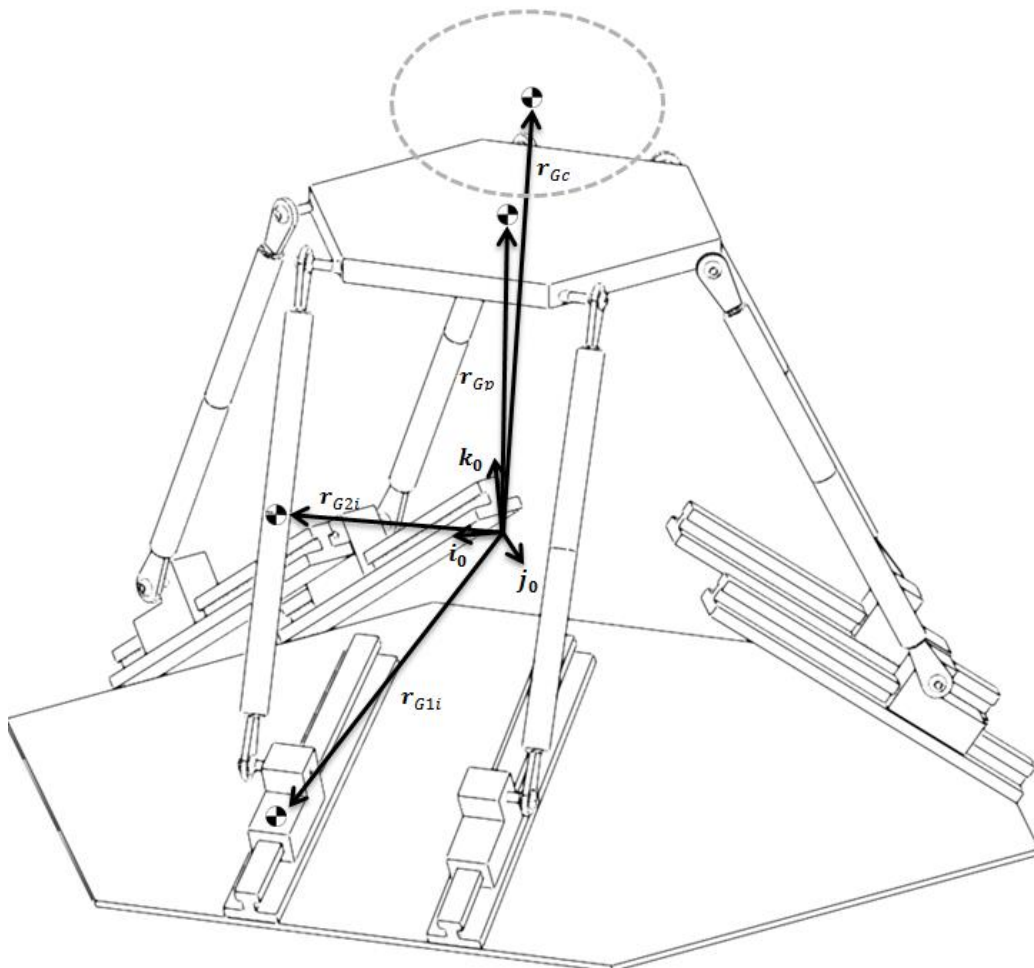

Fig. 3.2 Vectores de centro de gravedad

3.2.1. Posición y Velocidad de Centro de Gravedad del Cuerpo 1i

El objetivo de estas secciones, es poder encontrar ecuaciones que definan las posiciones y velocidades necesarias para las ecuaciones de energía cinética (3.2) y potencial (3.3). Dicho proceso será realizado para cada uno de los cuerpos tomados en cuenta.

Utilizando la representación vectorial, se tiene:

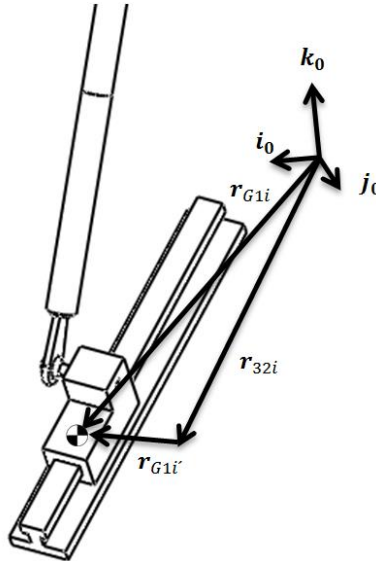

Fig. 3.3 Centro de Gravedad del Cuerpo 1i

Con el fin de obtener la velocidad del centro de gravedad del cuerpo 1i, y con base en la figura anterior, se tiene la siguiente ecuación de posición definida en la base inercial:

$$\mathbf{r}_{G1i}^0 = \mathbf{r}_{32i}^0 + \mathbf{r}_{G1i'}^0 \quad (3.5)$$

Donde:

$$\begin{aligned} \mathbf{r}_{32i}^0 &= x_{32i} \mathbf{i}_{2i}^0 \\ \mathbf{i}_{2i}^0 &= \mathbf{R}_{2i}^0 \mathbf{i}_{2i}^2 \\ \mathbf{i}_{2i}^2 &= [1, 0, 0]^T \end{aligned} \quad \begin{aligned} \mathbf{r}_{G1i'}^0 &= \mathbf{R}_{2i}^0 \mathbf{r}_{G1i'}^2 \\ \mathbf{r}_{G1i'}^2 &= [x_{G1i}, y_{G1i}, z_{G1i}]^T \end{aligned}$$

La matriz de rotación antes definida es:

$$\mathbf{R}_{2i}^0 = \mathbf{R}_z(\gamma_{10i}) \mathbf{R}_y(\beta_{21i})$$

Derivando respecto al tiempo la ecuación (3.5) se obtiene la velocidad del centro de gravedad:

$$\begin{aligned} \mathbf{v}_{G1i}^0 &= \mathbf{v}_{32i}^0 + \mathbf{v}_{G1i'}^0 = \mathbf{v}_{32i}^0 \\ \mathbf{v}_{G1i}^0 &= \dot{x}_{32i} \mathbf{i}_{2i}^0 \end{aligned} \quad (3.6)$$

Donde $\mathbf{v}_{G1i'}^0 = \mathbf{0}$, ya que es un vector de magnitud y orientación constante.

Además:

$$\dot{x}_{32i} = \frac{1}{V_{1i}} (V_{2i}\dot{x}_p + V_{3i}\dot{y}_p + V_{4i}\dot{z}_p + V_{5i}\dot{\theta}_p + V_{6i}\dot{\psi}_p + V_{7i}\dot{\phi}_p)$$

Haciendo cambio de variable, tenemos:

$$\dot{x}_{32i} = \mathbf{k}_{1i}^T \dot{\mathbf{q}} \quad (3.7)$$

Donde:

$$\begin{aligned} \mathbf{k}_{1i}^T &= \frac{1}{V_{1i}} [V_{2i}, V_{3i}, V_{4i}, V_{5i}, V_{6i}, V_{7i}] \\ \dot{\mathbf{q}} &= [\dot{x}_p, \dot{y}_p, \dot{z}_p, \dot{\theta}_p, \dot{\psi}_p, \dot{\phi}_p]^T \end{aligned}$$

Sustituyendo la ec. (3.7) en (3.6) con el fin de poner ésta última en términos de las coordenadas generalizadas, se tiene:

$$\begin{aligned} \mathbf{v}_{G1i}^0 &= \mathbf{i}_{2i}^0 \dot{x}_{32i} \\ \mathbf{v}_{G1i}^0 &= \mathbf{i}_{2i}^0 (\mathbf{k}_{1i}^T \dot{\mathbf{q}}) \\ \mathbf{v}_{G1i}^0 &= (\mathbf{i}_{2i}^0 \mathbf{k}_{1i}^T) \dot{\mathbf{q}} \end{aligned}$$

Renombrando:

$$\mathbf{v}_{G1i}^0 = \mathbf{M}_{1i} \dot{\mathbf{q}} \quad (3.8)$$

Donde:

$$\mathbf{M}_{1i} = \mathbf{i}_{2i}^0 \mathbf{k}_{1i}^T \quad (3.9)$$

Es importante destacar que el cuerpo 1i no realiza desplazamientos angulares, por lo que su velocidad angular es cero:

$$\boldsymbol{\omega}_{3i}^0 = \mathbf{0} \quad (3.10)$$

3.2.2. Posición y Velocidad de Centro de Gravedad del Cuerpo 2i

Utilizando la representación vectorial, se tiene:

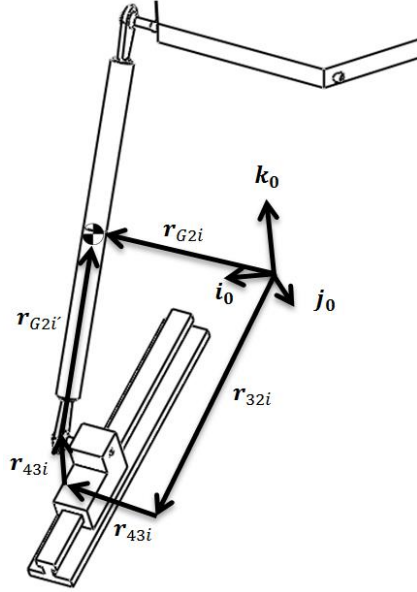

Fig. 3.4 Centro de Gravedad del Cuerpo 2i

Con el fin de obtener la velocidad del centro de gravedad del cuerpo 2_i, y con base en la figura anterior, se tiene la siguiente ecuación de posición definida en la base inercial:

$$\mathbf{r}_{G2i}^0 = \mathbf{r}_{32i}^0 + \mathbf{r}_{43i}^0 + \mathbf{r}_{54i}^0 + \mathbf{r}_{G2i'}^0 \quad (3.11)$$

Donde:

$$\begin{aligned} \mathbf{r}_{43i}^0 &= \mathbf{R}_{2i}^0 \mathbf{r}_{43i}^3 \\ \mathbf{r}_{43i}^3 &= [0, \pm b_{43i}, 0]^T \end{aligned}$$

$$\begin{aligned} \mathbf{r}_{G2i'}^0 &= \mathbf{R}_{7i}^0 \mathbf{r}_{G2i'}^7 \\ \mathbf{r}_{G2i'}^7 &= [x_{G2i}, 0, 0]^T \end{aligned}$$

$$\begin{aligned} \mathbf{r}_{54i}^0 &= \mathbf{R}_{2i}^0 \mathbf{r}_{54i}^4 \\ \mathbf{r}_{54i}^4 &= [0, 0, c_{54i}]^T \end{aligned}$$

La matriz de rotación antes definida es:

$$\mathbf{R}_{7i}^0 = \mathbf{R}_z(\gamma_{10i}) \mathbf{R}_y(\beta_{21i}) \mathbf{R}_y(\psi_{65i}) \mathbf{R}_z(\phi_{76i})$$

Derivando respecto al tiempo la ecuación (3.11) se obtiene la velocidad del centro de gravedad.

$$\begin{aligned}\mathbf{v}_{G2i}^0 &= \mathbf{v}_{32i}^0 + \mathbf{v}_{43i}^0 + \mathbf{v}_{54i}^0 + \mathbf{v}_{G2i'}^0 \\ &= \dot{x}_{32i} \mathbf{i}_{2i}^0 + \mathbf{0} + \mathbf{0} + \boldsymbol{\omega}_{7i}^0 \times \mathbf{r}_{G2i'}^0\end{aligned}\quad (3.12)$$

Donde $\mathbf{v}_{43i}^0 = \mathbf{v}_{54i}^0 = \mathbf{0}$, ya que es un vector de magnitud y orientación constante, y:

$$\mathbf{v}_{G2i'}^0 = \boldsymbol{\omega}_{7i}^0 \times \mathbf{r}_{G2i'}^0$$

Debido a que el cuerpo 2_i únicamente realiza movimientos rotacionales con respecto a la base móvil 7_i . Además, el vector de velocidad angular inercial $\boldsymbol{\omega}_{7i}^0$ para el cuerpo 2_i respecto a la base inercial, se define como:

$$\boldsymbol{\omega}_{7i}^0 = \boldsymbol{\omega}_{65i}^0 + \boldsymbol{\omega}_{76i}^0 \quad (3.13)$$

En donde:

$$\begin{aligned}\boldsymbol{\omega}_{65i}^0 &= \dot{\psi}_{65i} \mathbf{j}_{5i}^0 \\ \boldsymbol{\omega}_{76i}^0 &= \dot{\phi}_{76i} \mathbf{k}_{6i}^0\end{aligned}$$

Sustituyendo la ecuación (3.13) en la ecuación (3.12), y desarrollando:

$$\begin{aligned}\mathbf{v}_{G2i}^0 &= \dot{x}_{32i} \mathbf{i}_{2i}^0 + (\boldsymbol{\omega}_{65i}^0 + \boldsymbol{\omega}_{76i}^0) \times \mathbf{r}_{G2i'}^0 \\ &= \dot{x}_{32i} \mathbf{i}_{2i}^0 + (\dot{\psi}_{65i} \mathbf{j}_{5i}^0 + \dot{\phi}_{76i} \mathbf{k}_{6i}^0) \times \mathbf{r}_{G2i'}^0 \\ &= \mathbf{i}_{2i}^0 \dot{x}_{32i} + (\mathbf{j}_{5i}^0 \times \mathbf{r}_{G2i'}^0) \dot{\psi}_{65i} + (\mathbf{k}_{6i}^0 \times \mathbf{r}_{G2i'}^0) \dot{\phi}_{76i}\end{aligned}\quad (3.14)$$

En donde:

$$\begin{aligned}\mathbf{j}_{5i}^0 &= \mathbf{R}_{5i}^0 \mathbf{j}_{5i}^5 \\ \mathbf{k}_{6i}^0 &= \mathbf{R}_{6i}^0 \mathbf{j}_{6i}^6 \\ \mathbf{R}_{5i}^0 &= \mathbf{R}_z(\gamma_{10i}) \mathbf{R}_y(\beta_{21i}) \\ \mathbf{R}_{6i}^0 &= \mathbf{R}_z(\gamma_{10i}) \mathbf{R}_y(\beta_{21i}) \mathbf{R}_y(\psi_{65i}) \\ \mathbf{j}_{5i}^5 &= [0, 1, 0]^T \\ \mathbf{j}_{6i}^6 &= [0, 1, 0]^T\end{aligned}$$

Realizando cambio de variables en la ecuación (3.14), tenemos:

$$\mathbf{v}_{G2i}^0 = \mathbf{i}_{2i}^0 \dot{x}_{32i} + \mathbf{k}_{2i} \dot{\psi}_{65i} + \mathbf{k}_{3i} \dot{\phi}_{76i} \quad (3.15)$$

Donde:

$$\begin{aligned}\mathbf{k}_{2i} &= \mathbf{j}_{5i}^0 \times \mathbf{r}_{G2i'}^0 \\ \mathbf{k}_{3i} &= \mathbf{k}_{6i}^0 \times \mathbf{r}_{G2i'}^0\end{aligned}$$

Además:

$$\dot{\psi}_{65i} = \frac{1}{V_{8i}} (E_{1i}\dot{x}_p + E_{2i}\dot{y}_p + E_{3i}\dot{z}_p + E_{4i}\dot{\theta}_p + E_{5i}\dot{\psi}_p + E_{6i}\dot{\phi}_p)$$

$$\dot{\phi}_{76i} = \frac{1}{V_{16i}} (E_{7i}\dot{x}_p + E_{8i}\dot{y}_p + E_{9i}\dot{z}_p + E_{10i}\dot{\theta}_p + E_{11i}\dot{\psi}_p + E_{12i}\dot{\phi}_p)$$

Realizando cambio de variable en las últimas dos ecuaciones:

$$\dot{\psi}_{65i} = \mathbf{k}_{4i}^T \dot{\mathbf{q}} \quad (3.16)$$

$$\dot{\phi}_{76i} = \mathbf{k}_{5i}^T \dot{\mathbf{q}} \quad (3.17)$$

Donde:

$$\mathbf{k}_{4i}^T = \frac{1}{V_{8i}} [E_{1i}, E_{2i}, E_{3i}, E_{4i}, E_{5i}, E_{6i}]$$

$$\mathbf{k}_{5i}^T = \frac{1}{V_{16i}} [E_{7i}, E_{8i}, E_{9i}, E_{10i}, E_{11i}, E_{12i}]$$

Sustituyendo las ecs. (3.7), (3.16) y (3.17) en (3.15), con el fin de poner ésta última en términos de las coordenadas generalizadas, se tiene:

$$\begin{aligned} \mathbf{v}_{G2i}^0 &= \mathbf{i}_{2i}^0 \mathbf{k}_{1i}^T \dot{\mathbf{q}} + \mathbf{k}_{2i} \mathbf{k}_{4i}^T \dot{\mathbf{q}} + \mathbf{k}_{3i} \mathbf{k}_{5i}^T \dot{\mathbf{q}} \\ \mathbf{v}_{G2i}^0 &= (\mathbf{i}_{2i}^0 \mathbf{k}_{1i}^T + \mathbf{k}_{2i} \mathbf{k}_{4i}^T + \mathbf{k}_{3i} \mathbf{k}_{5i}^T) \dot{\mathbf{q}} \end{aligned} \quad (3.18)$$

Renombrando la ec. (3.18):

$$\mathbf{v}_{G2i}^0 = \mathbf{M}_{2i} \dot{\mathbf{q}} \quad (3.19)$$

Donde:

$$\mathbf{M}_{2i} = \mathbf{i}_{2i}^0 \mathbf{k}_{1i}^T + \mathbf{k}_{2i} \mathbf{k}_{4i}^T + \mathbf{k}_{3i} \mathbf{k}_{5i}^T \quad (3.20)$$

3.2.3. Velocidad Angular del Centro de Gravedad del Cuerpo 2i

Desarrollando la ec. (3.13), se tiene:

$$\begin{aligned} \boldsymbol{\omega}_{7i}^0 &= \boldsymbol{\omega}_{65i}^0 + \boldsymbol{\omega}_{76i}^0 \\ \boldsymbol{\omega}_{7i}^0 &= \mathbf{j}_{5i}^0 \dot{\psi}_{65i} + \mathbf{k}_{6i}^0 \dot{\phi}_{76i} \\ \boldsymbol{\omega}_{7i}^0 &= \mathbf{j}_{5i}^0 \mathbf{k}_{4i}^T \dot{\mathbf{q}} + \mathbf{k}_{6i}^0 \mathbf{k}_{5i}^T \dot{\mathbf{q}} \\ \boldsymbol{\omega}_{7i}^0 &= (\mathbf{j}_{5i}^0 \mathbf{k}_{4i}^T + \mathbf{k}_{6i}^0 \mathbf{k}_{5i}^T) \dot{\mathbf{q}} \end{aligned}$$

Finalmente:

$$\omega_{7i}^0 = M_{3i} \dot{q} \quad (3.21)$$

Donde:

$$M_{3i} = J_{5i}^0 k_{4i}^T + k_{6i}^0 k_{5i}^T \quad (3.22)$$

3.2.4. Posición y Velocidad de Centro de Gravedad del Plato Móvil

Utilizando la representación vectorial, se tiene:

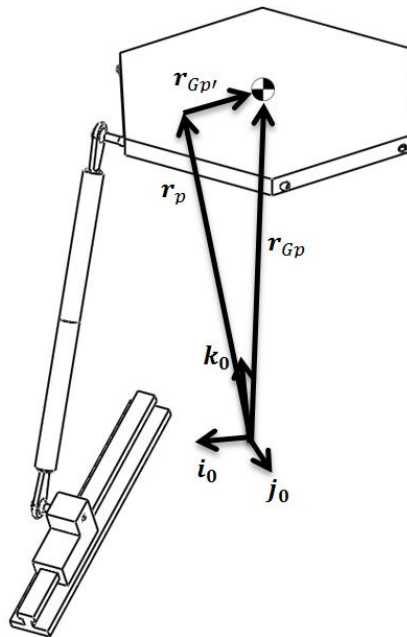

Fig. 3.5 Centro de Gravedad de la Plataforma

Con el fin de obtener la velocidad del centro de gravedad del plato móvil, y con base en la figura anterior, se tiene la siguiente ecuación de posición definida en la base inercial:

$$r_{Gp}^0 = r_p^0 + r_{Gp'}^0 \quad (3.23)$$

Sin embargo, si consideramos que la plataforma es una superficie de forma regular y uniforme, en la cual coincide su centroide con su centro de masa, podemos prescindir del vector $r_{Gp'}^0$, y llegar directamente al centro de gravedad utilizando únicamente el vector r_p^0 , esto es:

$$r_{Gp}^0 = r_p^0 \quad (3.24)$$

Donde:

$$\mathbf{r}_p^0 = [x_p, y_p, z_p]^T$$

Derivando respecto al tiempo la ecuación (3.24) se obtiene la velocidad del centro de gravedad:

$$\mathbf{v}_{Gp}^0 = \mathbf{v}_p^0$$

En donde:

$$\mathbf{v}_{Gp}^0 = [\dot{x}_p, \dot{y}_p, \dot{z}_p]^T$$

Haciendo un cambio de variable, tenemos:

$$\mathbf{v}_{Gp}^0 = \mathbf{M}_4 \dot{\mathbf{q}} \quad (3.25)$$

Donde:

$$\mathbf{M}_4 = \begin{bmatrix} 1 & 0 & 0 & 0 & 0 & 0 \\ 0 & 1 & 0 & 0 & 0 & 0 \\ 0 & 0 & 1 & 0 & 0 & 0 \end{bmatrix} \quad (3.26)$$

3.2.5. Velocidad Angular del Centro de Gravedad del Plato Móvil

El vector de velocidad angular inercial $\boldsymbol{\omega}_p^0$ del plato móvil se define como:

$$\begin{aligned} \boldsymbol{\omega}_p^0 &= \boldsymbol{\omega}_\theta^0 + \boldsymbol{\omega}_\psi^0 + \boldsymbol{\omega}_\phi^0 \\ \boldsymbol{\omega}_p^0 &= \mathbf{i}_0^0 \dot{\theta}_p + \mathbf{j}_{15}^0 \dot{\psi}_p + \mathbf{k}_{16}^0 \dot{\phi}_p \end{aligned} \quad (3.27)$$

Donde:

$$\begin{aligned} \mathbf{j}_{15}^0 &= \mathbf{R}_{15}^0 \mathbf{j}_{15}^{15} & \mathbf{i}_0^0 &= [1, 0, 0]^T \\ \mathbf{k}_{16}^0 &= \mathbf{R}_{16}^0 \mathbf{k}_{16}^{16} & \mathbf{j}_{15}^{15} &= [0, 1, 0]^T \\ & & \mathbf{k}_{16}^{16} &= [0, 0, 1]^T \end{aligned}$$

Las matrices de rotación anteriormente definidas, son:

$$\begin{aligned} \mathbf{R}_{15}^0 &= \mathbf{R}_x(\theta_p) \\ \mathbf{R}_{16}^0 &= \mathbf{R}_x(\theta_p) \mathbf{R}_y(\psi_p) \end{aligned}$$

Se define entonces:

$$\dot{\theta}_p = \mathbf{k}_6^T \dot{\mathbf{q}} \quad (3.28)$$

$$\dot{\psi}_p = \mathbf{k}_7^T \dot{\mathbf{q}} \quad (3.29)$$

$$\dot{\phi}_p = \mathbf{k}_8^T \dot{\mathbf{q}} \quad (3.30)$$

Donde:

$$\mathbf{k}_6^T = [0, 0, 0, 1, 0, 0]$$

$$\mathbf{k}_7^T = [0, 0, 0, 0, 1, 0]$$

$$\mathbf{k}_8^T = [0, 0, 0, 0, 0, 1]$$

Sustituyendo las ecuaciones (3.28), (3.29) y (3.30) en (3.27):

$$\boldsymbol{\omega}_p^0 = \mathbf{i}_0^0 \mathbf{k}_6^T \dot{\mathbf{q}} + \mathbf{j}_{15}^0 \mathbf{k}_7^T \dot{\mathbf{q}} + \mathbf{k}_{16}^0 \mathbf{k}_8^T \dot{\mathbf{q}}$$

$$\boldsymbol{\omega}_p^0 = (\mathbf{i}_0^0 \mathbf{k}_6^T + \mathbf{j}_{15}^0 \mathbf{k}_7^T + \mathbf{k}_{16}^0 \mathbf{k}_8^T) \dot{\mathbf{q}}$$

Finalmente:

$$\boldsymbol{\omega}_p^0 = \mathbf{M}_5 \dot{\mathbf{q}} \quad (3.31)$$

Se define \mathbf{M}_5 como sigue:

$$\mathbf{M}_5 = \mathbf{i}_0^0 \mathbf{k}_6^T + \mathbf{j}_{15}^0 \mathbf{k}_7^T + \mathbf{k}_{16}^0 \mathbf{k}_8^T \quad (3.32)$$

3.2.6. Posición y Velocidad de Centro de Gravedad de la Carga

Utilizando la representación vectorial, se tiene:

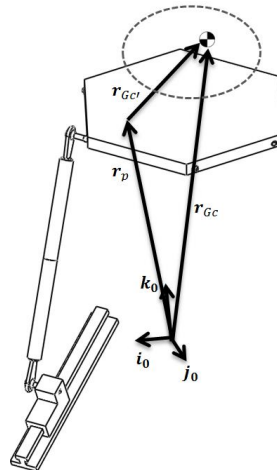

Fig. 3.6 Centro de Gravedad de la Carga

Con el fin de obtener la velocidad del centro de gravedad de la carga, y con base en la figura anterior, se tiene la siguiente ecuación de posición definida en la base inercial:

$$\mathbf{r}_{Gc}^0 = \mathbf{r}_p^0 + \mathbf{r}_{Gc'}^0 \quad (3.33)$$

Donde:

$$\begin{aligned} \mathbf{r}_{Gc'}^0 &= \mathbf{R}_p^0 \mathbf{r}_{Gc}^p \\ \mathbf{r}_{Gc}^p &= [x_{Gc}, y_{Gc}, z_{Gc}]^T \end{aligned}$$

La matriz de rotación anteriormente definida, es:

$$\mathbf{R}_p^0 = \mathbf{R}_x(\theta_p) \mathbf{R}_y(\psi_p) \mathbf{R}_z(\phi_p)$$

Derivando respecto al tiempo la ecuación (3.33), se obtiene la velocidad del centro de gravedad de la carga:

$$\begin{aligned} \mathbf{v}_{Gc}^0 &= \mathbf{v}_p^0 + \mathbf{v}_{Gc'}^0 \\ \mathbf{v}_{Gc}^0 &= \mathbf{v}_p^0 + \boldsymbol{\omega}_c^0 \times \mathbf{r}_{Gc'}^0 \end{aligned} \quad (3.34)$$

Donde:

$$\mathbf{v}_{Gc'}^0 = \boldsymbol{\omega}_c^0 \times \mathbf{r}_{Gc'}^0$$

Debido a que la carga únicamente realiza movimientos rotacionales con respecto a la base móvil 17_i. Además, el vector de velocidad angular inercial $\boldsymbol{\omega}_c^0$ para la carga respecto a la base inercial, se define como:

$$\boldsymbol{\omega}_c^0 = \boldsymbol{\omega}_{\theta p}^0 + \boldsymbol{\omega}_{\psi p}^0 + \boldsymbol{\omega}_{\phi p}^0 \quad (3.35)$$

Tras sustituir la ec. (3.35) en la ec. (3.34), tenemos:

$$\begin{aligned} \mathbf{v}_{Gc}^0 &= \mathbf{v}_p^0 + (\boldsymbol{\omega}_{\theta p}^0 + \boldsymbol{\omega}_{\psi p}^0 + \boldsymbol{\omega}_{\phi p}^0) \times \mathbf{r}_{Gc'}^0 \\ \mathbf{v}_{Gc}^0 &= \mathbf{v}_p^0 + (\dot{\theta}_p \mathbf{i}_0^0 + \dot{\psi}_p \mathbf{j}_{15}^0 + \dot{\phi}_p \mathbf{k}_{16}^0) \times \mathbf{r}_{Gc'}^0 \\ \mathbf{v}_{Gc}^0 &= \mathbf{v}_p^0 + (\mathbf{i}_0^0 \times \mathbf{r}_{Gc'}^0) \dot{\theta}_p + (\mathbf{j}_{15}^0 \times \mathbf{r}_{Gc'}^0) \dot{\psi}_p + (\mathbf{k}_{16}^0 \times \mathbf{r}_{Gc'}^0) \dot{\phi}_p \end{aligned}$$

Finalmente:

$$\mathbf{v}_{Gc}^0 = \mathbf{v}_p^0 + \mathbf{k}_9 \dot{\theta}_p + \mathbf{k}_{10} \dot{\psi}_p + \mathbf{k}_{11} \dot{\phi}_p \quad (3.35)$$

Donde:

$$\begin{aligned} \mathbf{k}_9 &= \mathbf{i}_0^0 \times \mathbf{r}_{GC'}^0 \\ \mathbf{k}_{10} &= \mathbf{J}_{15}^0 \times \mathbf{r}_{GC'}^0 \\ \mathbf{k}_{11} &= \mathbf{k}_{16}^0 \times \mathbf{r}_{GC'}^0 \end{aligned}$$

Sustituyendo ec. (3.25), (3.28), (3.29) y (3.30) en (3.35), obtenemos:

$$\begin{aligned} \mathbf{v}_{GC}^0 &= \mathbf{M}_4 \dot{\mathbf{q}} + \mathbf{k}_9 \mathbf{k}_6^T \dot{\mathbf{q}} + \mathbf{k}_{10} \mathbf{k}_7^T \dot{\mathbf{q}} + \mathbf{k}_{11} \mathbf{k}_8^T \dot{\mathbf{q}} \\ \mathbf{v}_{GC}^0 &= (\mathbf{M}_4 + \mathbf{k}_9 \mathbf{k}_6^T + \mathbf{k}_{10} \mathbf{k}_7^T + \mathbf{k}_{11} \mathbf{k}_8^T) \dot{\mathbf{q}} \end{aligned} \quad (3.36)$$

Finalmente, tras realizar un cambio de variable en la ec. 3.36, obtenemos:

$$\mathbf{v}_{GC}^0 = \mathbf{M}_6 \dot{\mathbf{q}} \quad (3.37)$$

Donde:

$$\mathbf{M}_6 = \mathbf{M}_4 + \mathbf{k}_9 \mathbf{k}_6^T + \mathbf{k}_{10} \mathbf{k}_7^T + \mathbf{k}_{11} \mathbf{k}_8^T \quad (3.38)$$

3.2.7. Velocidad Angular del Centro de Gravedad de la Carga

Debido a que la carga se encuentra fija al plato móvil, se observa que la velocidad angular de la carga y del plato son ambas la misma, es decir:

$$\boldsymbol{\omega}_c^0 = \boldsymbol{\omega}_p^0 = \mathbf{M}_5 \dot{\mathbf{q}} \quad (3.39)$$

3.3. Función Lagrangiana

Aplicando la ec. (3.1) se consigue de manera general la siguiente expresión:

$$L = \sum_{i=1}^6 \left(\sum_{k=1}^2 (K_{ki} - U_{ki}) \right) + L_p + L_c$$

i = Número de la cadena

k = Número de cuerpos en la cadena i

Expandiendo los términos del primer paréntesis:

$$\begin{aligned} L &= \sum_{i=1}^6 ((K_{1i} - U_{1i}) + (K_{2i} - U_{2i})) + (K_p - U_p) + (K_c - U_c) \\ L &= \sum_{i=1}^6 (L_{1i} + L_{2i}) + L_p + L_c \end{aligned} \quad (3.40)$$

Donde $L_{ki} = K_{ki} - U_{ki}$

$$\begin{aligned} L_{1i} &= \frac{1}{2}(m_{1i}(\mathbf{v}_{G1i}^0)^T \mathbf{v}_{G1i}^0) + m_{1i} \mathbf{g}^T \mathbf{r}_{G1i}^0 \\ L_{2i} &= \frac{1}{2}(m_{2i}(\mathbf{v}_{G2i}^0)^T \mathbf{v}_{G2i}^0 + (\boldsymbol{\omega}_{7i}^0)^T \mathbf{J}_{G1i} \boldsymbol{\omega}_{7i}^0) + m_{2i} \mathbf{g}^T \mathbf{r}_{G2i}^0 \\ L_p &= \frac{1}{2}(m_p(\mathbf{v}_{Gp}^0)^T \mathbf{v}_{Gp}^0 + (\boldsymbol{\omega}_p^0)^T \mathbf{J}_{Gp} \boldsymbol{\omega}_p^0) + m_p \mathbf{g}^T \mathbf{r}_{Gp}^0 \\ L_c &= \frac{1}{2}(m_c(\mathbf{v}_{Gc}^0)^T \mathbf{v}_{Gc}^0 + (\boldsymbol{\omega}_c^0)^T \mathbf{J}_{Gc} \boldsymbol{\omega}_c^0) + m_c \mathbf{g}^T \mathbf{r}_{Gc}^0 \end{aligned}$$

Donde $\mathbf{g} = [0, 0, -9.81]^T$

3.3.1. Desarrollo del Primer Término de la Ecuación de Lagrange

Desarrollando el término $\frac{d}{dt} \left(\frac{\partial L}{\partial \dot{q}_j} \right)$

Se tiene la siguiente ecuación definida al principio del capítulo:

$$\frac{d}{dt} \left(\frac{\partial L}{\partial \dot{q}_j} \right) - \frac{\partial L}{\partial q_j} = Q_j \quad (3.4)$$

Desarrollando el primer término de la ecuación (3.4) a partir de la ecuación (3.40):

$$\frac{\partial L}{\partial \dot{q}_j} = \sum_{i=1}^6 \left(\frac{\partial L_{1i}}{\partial \dot{q}_j} + \frac{\partial L_{2i}}{\partial \dot{q}_j} \right) + \frac{\partial L_p}{\partial \dot{q}_j} + \frac{\partial L_c}{\partial \dot{q}_j} \quad (3.41)$$

Para $j=1,2,3,4,5,6$, donde:

$$\begin{aligned} \dot{q}_1 &= \dot{x}_p & \dot{q}_2 &= \dot{y}_p & \dot{q}_3 &= \dot{z}_p \\ \dot{q}_4 &= \dot{\theta}_p & \dot{q}_5 &= \dot{\psi}_p & \dot{q}_6 &= \dot{\phi}_p \end{aligned}$$

Desarrollando $\frac{\partial L_{1i}}{\partial \dot{q}_j}$

A partir de la definición del Lagrangiano en la ec. 3.1, se procede a desarrollar el primer término de la ec. (3.41):

$$\begin{aligned} L_{1i} &= \frac{1}{2}(m_{1i}(\mathbf{v}_{G1i}^0)^T \mathbf{v}_{G1i}^0) + m_{1i} \mathbf{g}^T \mathbf{r}_{G1i}^0 \\ &= \frac{1}{2}(m_{1i}(\mathbf{M}_{1i} \dot{\mathbf{q}})^T \mathbf{M}_{1i} \dot{\mathbf{q}}) + m_{1i} \mathbf{g}^T \mathbf{r}_{G1i}^0 \end{aligned}$$

$$\begin{aligned}
 &= \frac{1}{2} (m_{1i} \dot{\mathbf{q}}^T (\mathbf{M}_{1i}^T \mathbf{M}_{1i}) \dot{\mathbf{q}}) + m_{1i} \mathbf{g}^T \mathbf{r}_{G1i}^0 \\
 &= \frac{1}{2} \dot{\mathbf{q}}^T (m_{1i} \mathbf{M}_{1i}^T \mathbf{M}_{1i}) \dot{\mathbf{q}} + m_{1i} \mathbf{g}^T \mathbf{r}_{G1i}^0 \\
 L_{1i} &= \frac{1}{2} \dot{\mathbf{q}}^T \mathbf{N}_{1i} \dot{\mathbf{q}} + m_{1i} \mathbf{g}^T \mathbf{r}_{G1i}^0
 \end{aligned} \tag{3.42}$$

Donde:

$$\mathbf{N}_{1i} = m_{1i} \mathbf{M}_{1i}^T \mathbf{M}_{1i}$$

Aplicando la derivada parcial respecto a \dot{q}_j a la ec. (3.42):

$$\begin{aligned}
 \frac{\partial L_{1i}}{\partial \dot{q}_j} &= \frac{\partial}{\partial \dot{q}_j} \left(\frac{1}{2} \dot{\mathbf{q}}^T \mathbf{N}_{1i} \dot{\mathbf{q}} + m_{1i} \mathbf{g}^T \mathbf{r}_{G1i}^0 \right) \\
 &= \frac{1}{2} \left(\frac{\partial \dot{\mathbf{q}}^T}{\partial \dot{q}_j} \mathbf{N}_{1i} \dot{\mathbf{q}} + \dot{\mathbf{q}}^T \frac{\partial \mathbf{N}_{1i}}{\partial \dot{q}_j} \dot{\mathbf{q}} + \dot{\mathbf{q}}^T \mathbf{N}_{1i} \frac{\partial \dot{\mathbf{q}}}{\partial \dot{q}_j} \right) \\
 \frac{\partial L_{1i}}{\partial \dot{q}_j} &= \frac{1}{2} \left(\frac{\partial \dot{\mathbf{q}}^T}{\partial \dot{q}_j} \mathbf{N}_{1i} \dot{\mathbf{q}} + \dot{\mathbf{q}}^T \mathbf{N}_{1i} \frac{\partial \dot{\mathbf{q}}}{\partial \dot{q}_j} \right)
 \end{aligned} \tag{3.43}$$

Por otra parte, tenemos la siguiente identidad:

$$\left(\frac{\partial \dot{\mathbf{q}}^T}{\partial \dot{q}_j} \mathbf{N}_{1i} \right) \dot{\mathbf{q}} = \mathbf{A}^T \dot{\mathbf{q}} = \dot{\mathbf{q}}^T \mathbf{A} = \dot{\mathbf{q}}^T \left(\mathbf{N}_{1i}^T \frac{\partial \dot{\mathbf{q}}}{\partial \dot{q}_j} \right) \tag{3.44}$$

Aplicando dicha identidad a la ec. (3.43), obtenemos la siguiente expresión:

$$\begin{aligned}
 \frac{\partial L_{1i}}{\partial \dot{q}_j} &= \frac{1}{2} \left(\dot{\mathbf{q}}^T \mathbf{N}_{1i}^T \frac{\partial \dot{\mathbf{q}}}{\partial \dot{q}_j} + \dot{\mathbf{q}}^T \mathbf{N}_{1i} \frac{\partial \dot{\mathbf{q}}}{\partial \dot{q}_j} \right) \\
 &= \frac{1}{2} \left(\dot{\mathbf{q}}^T (\mathbf{N}_{1i}^T + \mathbf{N}_{1i}) \frac{\partial \dot{\mathbf{q}}}{\partial \dot{q}_j} \right) \\
 &= \frac{1}{2} \left(\dot{\mathbf{q}}^T (2\mathbf{N}_{1i}) \frac{\partial \dot{\mathbf{q}}}{\partial \dot{q}_j} \right) \\
 \frac{\partial L_{1i}}{\partial \dot{q}_j} &= \dot{\mathbf{q}}^T \mathbf{N}_{1i} \frac{\partial \dot{\mathbf{q}}}{\partial \dot{q}_j}
 \end{aligned} \tag{3.45}$$

Donde \mathbf{N}_{1i} es una matriz simétrica, es decir $\mathbf{N}_{1i} = \mathbf{N}_{1i}^T$, comprobando lo anterior:

$$\mathbf{N}_{1i}^T = (m_{1i} \mathbf{M}_{1i}^T \mathbf{M}_{1i})^T = m_{1i} (\mathbf{M}_{1i}^T \mathbf{M}_{1i})^T = m_{1i} \mathbf{M}_{1i}^T \mathbf{M}_{1i} = \mathbf{N}_{1i}$$

Desarrollando $\frac{\partial L_{2i}}{\partial \dot{q}_j}$

A partir de la definición del Lagrangiano en la ec. 3.1, se procede a desarrollar el segundo término de la ec. (3.41):

$$\begin{aligned}
 L_{2i} &= \frac{1}{2} (m_{2i} (\mathbf{v}_{G2i}^0)^T \mathbf{v}_{G2i}^0 + (\boldsymbol{\omega}_{7i}^0)^T \mathbf{J}_{G2i}^0 \boldsymbol{\omega}_{7i}^0) + m_{2i} \mathbf{g}^T \mathbf{r}_{G2i}^0 \\
 &= \frac{1}{2} (m_{2i} (\mathbf{M}_{2i} \dot{\mathbf{q}})^T \mathbf{M}_{2i} \dot{\mathbf{q}} + (\mathbf{M}_{3i} \dot{\mathbf{q}})^T \mathbf{J}_{G2i}^0 \mathbf{M}_{3i} \dot{\mathbf{q}}) + m_{2i} \mathbf{g}^T \mathbf{r}_{G2i}^0 \\
 &= \frac{1}{2} (m_{2i} \dot{\mathbf{q}}^T (\mathbf{M}_{2i}^T \mathbf{M}_{2i}) \dot{\mathbf{q}} + \dot{\mathbf{q}}^T (\mathbf{M}_{3i}^T \mathbf{J}_{G2i}^0 \mathbf{M}_{3i}) \dot{\mathbf{q}}) + m_{2i} \mathbf{g}^T \mathbf{r}_{G2i}^0 \\
 &= \frac{1}{2} \dot{\mathbf{q}}^T (m_{2i} \mathbf{M}_{2i}^T \mathbf{M}_{2i} + \mathbf{M}_{3i}^T \mathbf{J}_{G2i}^0 \mathbf{M}_{3i}) \dot{\mathbf{q}} + m_{2i} \mathbf{g}^T \mathbf{r}_{G2i}^0 \\
 L_{2i} &= \frac{1}{2} \dot{\mathbf{q}}^T \mathbf{N}_{2i} \dot{\mathbf{q}} + m_{2i} \mathbf{g}^T \mathbf{r}_{G2i}^0
 \end{aligned} \tag{3.46}$$

Donde:

$$\begin{aligned}
 \mathbf{N}_{2i} &= m_{2i} \mathbf{M}_{2i}^T \mathbf{M}_{2i} + \mathbf{M}_{3i}^T \mathbf{J}_{G2i}^0 \mathbf{M}_{3i} \\
 \mathbf{J}_{G2i}^0 &= \mathbf{R}_{7i}^0 \mathbf{J}_{G2i}^7 \mathbf{R}_{7i}^{0T}
 \end{aligned}$$

Realizando la derivada parcial respecto a \dot{q}_j a la ec. (3.46):

$$\begin{aligned}
 \frac{\partial L_{2i}}{\partial \dot{q}_j} &= \frac{\partial}{\partial \dot{q}_j} \left(\frac{1}{2} \dot{\mathbf{q}}^T \mathbf{N}_{2i} \dot{\mathbf{q}} + m_{2i} \mathbf{g}^T \mathbf{r}_{G2i}^0 \right) \\
 &= \frac{1}{2} \left(\frac{\partial \dot{\mathbf{q}}^T}{\partial \dot{q}_j} \mathbf{N}_{2i} \dot{\mathbf{q}} + \dot{\mathbf{q}}^T \frac{\partial \mathbf{N}_{2i}}{\partial \dot{q}_j} \dot{\mathbf{q}} + \dot{\mathbf{q}}^T \mathbf{N}_{2i} \frac{\partial \dot{\mathbf{q}}}{\partial \dot{q}_j} \right) \\
 \frac{\partial L_{2i}}{\partial \dot{q}_j} &= \frac{1}{2} \left(\frac{\partial \dot{\mathbf{q}}^T}{\partial \dot{q}_j} \mathbf{N}_{2i} \dot{\mathbf{q}} + \dot{\mathbf{q}}^T \mathbf{N}_{2i} \frac{\partial \dot{\mathbf{q}}}{\partial \dot{q}_j} \right)
 \end{aligned} \tag{3.47}$$

Aplicando la identidad (3.44) a la ec. (3.47), obtenemos:

$$\begin{aligned}
 \frac{\partial L_{2i}}{\partial \dot{q}_j} &= \frac{1}{2} \left(\frac{\partial \dot{\mathbf{q}}^T}{\partial \dot{q}_j} \mathbf{N}_{2i} \dot{\mathbf{q}} + \dot{\mathbf{q}}^T \mathbf{N}_{2i} \frac{\partial \dot{\mathbf{q}}}{\partial \dot{q}_j} \right) \\
 &= \frac{1}{2} \left(\dot{\mathbf{q}}^T \mathbf{N}_{2i}^T \frac{\partial \dot{\mathbf{q}}}{\partial \dot{q}_j} + \dot{\mathbf{q}}^T \mathbf{N}_{2i} \frac{\partial \dot{\mathbf{q}}}{\partial \dot{q}_j} \right) \\
 &= \frac{1}{2} \left(\dot{\mathbf{q}}^T (\mathbf{N}_{2i}^T + \mathbf{N}_{2i}) \frac{\partial \dot{\mathbf{q}}}{\partial \dot{q}_j} \right) \\
 &= \frac{1}{2} \left(\dot{\mathbf{q}}^T (2\mathbf{N}_{2i}) \frac{\partial \dot{\mathbf{q}}}{\partial \dot{q}_j} \right) \\
 \frac{\partial L_{2i}}{\partial \dot{q}_j} &= \dot{\mathbf{q}}^T \mathbf{N}_{2i} \frac{\partial \dot{\mathbf{q}}}{\partial \dot{q}_j}
 \end{aligned} \tag{3.48}$$

Donde N_{2i} es una matriz simétrica, es decir $N_{2i} = N_{2i}^T$, comprobando lo anterior:

$$\begin{aligned}
 N_{2i}^T &= (m_{2i} \mathbf{M}_{2i}^T \mathbf{M}_{2i} + \mathbf{M}_{3i}^T \mathbf{J}_{G2i}^0 \mathbf{M}_{3i})^T \\
 &= (m_{2i} \mathbf{M}_{2i}^T \mathbf{M}_{2i})^T + (\mathbf{M}_{3i}^T \mathbf{J}_{G2i}^0 \mathbf{M}_{3i})^T \\
 &= m_{2i} (\mathbf{M}_{2i}^T \mathbf{M}_{2i})^T + (\mathbf{M}_{3i}^T \mathbf{J}_{G2i}^0 \mathbf{M}_{3i})^T \\
 N_{2i}^T &= m_{2i} \mathbf{M}_{2i}^T \mathbf{M}_{2i} + \mathbf{M}_{3i}^T \mathbf{J}_{G2i}^0 \mathbf{M}_{3i}
 \end{aligned} \tag{3.49}$$

Finalmente, como el tensor de Inercia \mathbf{J}_{G2i}^0 es, a su vez, una matriz simétrica también, se cumple que:

$$\mathbf{J}_{G2i}^0{}^T = \mathbf{J}_{G2i}^0$$

Aplicando este resultado a la ecuación anterior (3.49), concluimos que:

$$N_{2i}^T = m_{2i} \mathbf{M}_{2i}^T \mathbf{M}_{2i} + \mathbf{M}_{3i}^T \mathbf{J}_{G2i}^0 \mathbf{M}_{3i} = N_{2i}$$

Desarrollando $\frac{\partial L_p}{\partial \dot{q}_j}$

A partir de la definición del Lagrangiano en la ec. 3.1, se procede a desarrollar el tercer término de la ec. (3.41):

$$\begin{aligned}
 L_p &= \frac{1}{2} (m_p (\mathbf{v}_{Gp}^0)^T \mathbf{v}_{Gp}^0 + (\boldsymbol{\omega}_p^0)^T \mathbf{J}_{Gp}^0 \boldsymbol{\omega}_p^0) + m_p \mathbf{g}^T \mathbf{r}_{Gp}^0 \\
 &= \frac{1}{2} (m_p (\mathbf{M}_4 \dot{\mathbf{q}})^T \mathbf{M}_4 \dot{\mathbf{q}} + (\mathbf{M}_5 \dot{\mathbf{q}})^T \mathbf{J}_{Gp}^0 \mathbf{M}_5 \dot{\mathbf{q}}) + m_p \mathbf{g}^T \mathbf{r}_{Gp}^0 \\
 &= \frac{1}{2} (m_p \dot{\mathbf{q}}^T (\mathbf{M}_4^T \mathbf{M}_4) \dot{\mathbf{q}} + \dot{\mathbf{q}}^T (\mathbf{M}_5^T \mathbf{J}_{Gp}^0 \mathbf{M}_5) \dot{\mathbf{q}}) + m_p \mathbf{g}^T \mathbf{r}_{Gp}^0 \\
 &= \frac{1}{2} \dot{\mathbf{q}}^T (m_p \mathbf{M}_4^T \mathbf{M}_4 + \mathbf{M}_5^T \mathbf{J}_{Gp}^0 \mathbf{M}_5) \dot{\mathbf{q}} + m_p \mathbf{g}^T \mathbf{r}_{Gp}^0 \\
 L_p &= \frac{1}{2} \dot{\mathbf{q}}^T \mathbf{N}_3 \dot{\mathbf{q}} + m_p \mathbf{g}^T \mathbf{r}_{Gp}^0
 \end{aligned} \tag{3.50}$$

Donde:

$$\begin{aligned}
 \mathbf{N}_3 &= m_p \mathbf{M}_4^T \mathbf{M}_4 + \mathbf{M}_5^T \mathbf{J}_{Gp}^0 \mathbf{M}_5 \\
 \mathbf{J}_{Gp}^0 &= \mathbf{R}_p^0 \mathbf{J}_{Gp}^p \mathbf{R}_p^{0T}
 \end{aligned}$$

Realizando la derivada parcial respecto a \dot{q}_j a la ec. (3.50):

$$\begin{aligned}
 \frac{\partial L_p}{\partial \dot{q}_j} &= \frac{\partial}{\partial \dot{q}_j} \left(\frac{1}{2} \dot{\mathbf{q}}^T \mathbf{N}_3 \dot{\mathbf{q}} + m_p \mathbf{g}^T \mathbf{r}_{Gp}^0 \right) \\
 &= \frac{1}{2} \left(\frac{\partial \dot{\mathbf{q}}^T}{\partial \dot{q}_j} \mathbf{N}_3 \dot{\mathbf{q}} + \dot{\mathbf{q}}^T \frac{\partial \mathbf{N}_3}{\partial \dot{q}_j} \dot{\mathbf{q}} + \dot{\mathbf{q}}^T \mathbf{N}_3 \frac{\partial \dot{\mathbf{q}}}{\partial \dot{q}_j} \right) \\
 \frac{\partial L_p}{\partial \dot{q}_j} &= \frac{1}{2} \left(\frac{\partial \dot{\mathbf{q}}^T}{\partial \dot{q}_j} \mathbf{N}_3 \dot{\mathbf{q}} + \dot{\mathbf{q}}^T \mathbf{N}_3 \frac{\partial \dot{\mathbf{q}}}{\partial \dot{q}_j} \right)
 \end{aligned} \tag{3.51}$$

Aplicando la identidad (3.44) a la ec. (3.51), obtenemos:

$$\begin{aligned}
 \frac{\partial L_p}{\partial \dot{q}_j} &= \frac{1}{2} \left(\frac{\partial \dot{\mathbf{q}}^T}{\partial \dot{q}_j} \mathbf{N}_3 \dot{\mathbf{q}} + \dot{\mathbf{q}}^T \mathbf{N}_3 \frac{\partial \dot{\mathbf{q}}}{\partial \dot{q}_j} \right) \\
 &= \frac{1}{2} \left(\dot{\mathbf{q}}^T \mathbf{N}_3^T \frac{\partial \dot{\mathbf{q}}}{\partial \dot{q}_j} + \dot{\mathbf{q}}^T \mathbf{N}_3 \frac{\partial \dot{\mathbf{q}}}{\partial \dot{q}_j} \right) \\
 &= \frac{1}{2} \left(\dot{\mathbf{q}}^T (\mathbf{N}_3^T + \mathbf{N}_3) \frac{\partial \dot{\mathbf{q}}}{\partial \dot{q}_j} \right) \\
 &= \frac{1}{2} \left(\dot{\mathbf{q}}^T (2\mathbf{N}_3) \frac{\partial \dot{\mathbf{q}}}{\partial \dot{q}_j} \right) \\
 \frac{\partial L_p}{\partial \dot{q}_j} &= \dot{\mathbf{q}}^T \mathbf{N}_3 \frac{\partial \dot{\mathbf{q}}}{\partial \dot{q}_j}
 \end{aligned} \tag{3.52}$$

Donde \mathbf{N}_3 es una matriz simétrica, es decir $\mathbf{N}_3 = \mathbf{N}_3^T$.

Desarrollando $\frac{\partial L_c}{\partial \dot{q}_j}$

A partir de la definición del Lagrangiano en la ec. 3.1, se procede a desarrollar el cuarto término de la ec. (3.41):

$$\begin{aligned}
 L_c &= \frac{1}{2} (m_c (\mathbf{v}_{Gc}^0)^T \mathbf{v}_{Gc}^0 + (\boldsymbol{\omega}_c^0)^T \mathbf{J}_{Gc}^0 \boldsymbol{\omega}_c^0) + m_c \mathbf{g}^T \mathbf{r}_{Gc}^0 \\
 &= \frac{1}{2} (m_c (\mathbf{M}_6 \dot{\mathbf{q}})^T \mathbf{M}_6 \dot{\mathbf{q}} + (\mathbf{M}_5 \dot{\mathbf{q}})^T \mathbf{J}_{Gc}^0 \mathbf{M}_5 \dot{\mathbf{q}}) + m_c \mathbf{g}^T \mathbf{r}_{Gc}^0 \\
 &= \frac{1}{2} (m_c \dot{\mathbf{q}}^T (\mathbf{M}_6^T \mathbf{M}_6) \dot{\mathbf{q}} + \dot{\mathbf{q}}^T (\mathbf{M}_5^T \mathbf{J}_{Gc}^0 \mathbf{M}_5) \dot{\mathbf{q}}) + m_c \mathbf{g}^T \mathbf{r}_{Gc}^0 \\
 &= \frac{1}{2} \dot{\mathbf{q}}^T (m_c \mathbf{M}_6^T \mathbf{M}_6 + \mathbf{M}_5^T \mathbf{J}_{Gc}^0 \mathbf{M}_5) \dot{\mathbf{q}} + m_c \mathbf{g}^T \mathbf{r}_{Gc}^0 \\
 L_c &= \frac{1}{2} \dot{\mathbf{q}}^T \mathbf{N}_4 \dot{\mathbf{q}} + m_c \mathbf{g}^T \mathbf{r}_{Gc}^0
 \end{aligned} \tag{3.53}$$

Donde:

$$\begin{aligned}
 \mathbf{N}_4 &= m_c \mathbf{M}_6^T \mathbf{M}_6 + \mathbf{M}_5^T \mathbf{J}_{Gc}^0 \mathbf{M}_5 \\
 \mathbf{J}_{Gc}^0 &= \mathbf{R}_p^0 \mathbf{J}_{Gc}^p \mathbf{R}_p^{0T}
 \end{aligned}$$

Realizando la derivada parcial respecto a \dot{q}_j a la ec. (3.53):

$$\begin{aligned}
 \frac{\partial L_c}{\partial \dot{q}_j} &= \frac{\partial}{\partial \dot{q}_j} \left(\frac{1}{2} \dot{\mathbf{q}}^T \mathbf{N}_4 \dot{\mathbf{q}} + m_c \mathbf{g}^T \mathbf{r}_{Gc}^0 \right) \\
 &= \frac{1}{2} \left(\frac{\partial \dot{\mathbf{q}}^T}{\partial \dot{q}_j} \mathbf{N}_4 \dot{\mathbf{q}} + \dot{\mathbf{q}}^T \frac{\partial \mathbf{N}_4}{\partial \dot{q}_j} \dot{\mathbf{q}} + \dot{\mathbf{q}}^T \mathbf{N}_4 \frac{\partial \dot{\mathbf{q}}}{\partial \dot{q}_j} \right) \\
 \frac{\partial L_c}{\partial \dot{q}_j} &= \frac{1}{2} \left(\frac{\partial \dot{\mathbf{q}}^T}{\partial \dot{q}_j} \mathbf{N}_4 \dot{\mathbf{q}} + \dot{\mathbf{q}}^T \mathbf{N}_4 \frac{\partial \dot{\mathbf{q}}}{\partial \dot{q}_j} \right)
 \end{aligned} \tag{3.54}$$

Aplicando la identidad (3.44) a la ec. (3.54), obtenemos:

$$\begin{aligned}
 \frac{\partial L_c}{\partial \dot{q}_j} &= \frac{1}{2} \left(\frac{\partial \dot{\mathbf{q}}^T}{\partial \dot{q}_j} \mathbf{N}_4 \dot{\mathbf{q}} + \dot{\mathbf{q}}^T \mathbf{N}_4 \frac{\partial \dot{\mathbf{q}}}{\partial \dot{q}_j} \right) \\
 &= \frac{1}{2} \left(\dot{\mathbf{q}}^T \mathbf{N}_4^T \frac{\partial \dot{\mathbf{q}}}{\partial \dot{q}_j} + \dot{\mathbf{q}}^T \mathbf{N}_4 \frac{\partial \dot{\mathbf{q}}}{\partial \dot{q}_j} \right) \\
 &= \frac{1}{2} \left(\dot{\mathbf{q}}^T (\mathbf{N}_4^T + \mathbf{N}_4) \frac{\partial \dot{\mathbf{q}}}{\partial \dot{q}_j} \right) \\
 &= \frac{1}{2} \left(\dot{\mathbf{q}}^T (2\mathbf{N}_4) \frac{\partial \dot{\mathbf{q}}}{\partial \dot{q}_j} \right) \\
 \frac{\partial L_c}{\partial \dot{q}_j} &= \dot{\mathbf{q}}^T \mathbf{N}_4 \frac{\partial \dot{\mathbf{q}}}{\partial \dot{q}_j}
 \end{aligned} \tag{3.55}$$

Donde \mathbf{N}_4 es una matriz simétrica, es decir $\mathbf{N}_4 = \mathbf{N}_4^T$.

Al evaluar el término $\frac{\partial \dot{\mathbf{q}}}{\partial \dot{q}_j}$, dependerá de qué valor tome j , de tal manera que se tienen los siguientes resultados para los diferentes valores del iterador. De esta forma, para:

$$j = 1$$

$$\begin{aligned}
 \frac{\partial \dot{\mathbf{q}}}{\partial \dot{q}_1} &= \frac{\partial}{\partial \dot{q}_1} [\dot{x}_p, \dot{y}_p, \dot{z}_p, \dot{\theta}_p, \dot{\psi}_p, \dot{\phi}_p]^T = \frac{\partial}{\partial \dot{x}_p} [\dot{x}_p, \dot{y}_p, \dot{z}_p, \dot{\theta}_p, \dot{\psi}_p, \dot{\phi}_p]^T \\
 \frac{\partial \dot{\mathbf{q}}}{\partial \dot{q}_1} &= [1, 0, 0, 0, 0, 0]^T
 \end{aligned}$$

$$j = 2$$

$$\begin{aligned}
 \frac{\partial \dot{\mathbf{q}}}{\partial \dot{q}_2} &= \frac{\partial}{\partial \dot{q}_2} [\dot{x}_p, \dot{y}_p, \dot{z}_p, \dot{\theta}_p, \dot{\psi}_p, \dot{\phi}_p]^T = \frac{\partial}{\partial \dot{y}_p} [\dot{x}_p, \dot{y}_p, \dot{z}_p, \dot{\theta}_p, \dot{\psi}_p, \dot{\phi}_p]^T \\
 \frac{\partial \dot{\mathbf{q}}}{\partial \dot{q}_2} &= [0, 1, 0, 0, 0, 0]^T
 \end{aligned}$$

$$j = 3$$

$$\begin{aligned}
 \frac{\partial \dot{\mathbf{q}}}{\partial \dot{q}_3} &= \frac{\partial}{\partial \dot{q}_3} [\dot{x}_p, \dot{y}_p, \dot{z}_p, \dot{\theta}_p, \dot{\psi}_p, \dot{\phi}_p]^T = \frac{\partial}{\partial \dot{z}_p} [\dot{x}_p, \dot{y}_p, \dot{z}_p, \dot{\theta}_p, \dot{\psi}_p, \dot{\phi}_p]^T \\
 \frac{\partial \dot{\mathbf{q}}}{\partial \dot{q}_3} &= [0, 0, 1, 0, 0, 0]^T
 \end{aligned}$$

$$j = 4$$

$$\begin{aligned}
 \frac{\partial \dot{\mathbf{q}}}{\partial \dot{q}_4} &= \frac{\partial}{\partial \dot{q}_4} [\dot{x}_p, \dot{y}_p, \dot{z}_p, \dot{\theta}_p, \dot{\psi}_p, \dot{\phi}_p]^T = \frac{\partial}{\partial \dot{\theta}_p} [\dot{x}_p, \dot{y}_p, \dot{z}_p, \dot{\theta}_p, \dot{\psi}_p, \dot{\phi}_p]^T \\
 \frac{\partial \dot{\mathbf{q}}}{\partial \dot{q}_4} &= [0, 0, 0, 1, 0, 0]^T
 \end{aligned}$$

$$j = 5$$

$$\begin{aligned}\frac{\partial \dot{\mathbf{q}}}{\partial \dot{q}_5} &= \frac{\partial}{\partial \dot{q}_5} [\dot{x}_p, \dot{y}_p, \dot{z}_p, \dot{\theta}_p, \dot{\psi}_p, \dot{\phi}_p]^T = \frac{\partial}{\partial \dot{\psi}_p} [\dot{x}_p, \dot{y}_p, \dot{z}_p, \dot{\theta}_p, \dot{\psi}_p, \dot{\phi}_p]^T \\ \frac{\partial \dot{\mathbf{q}}}{\partial \dot{q}_5} &= [0, 0, 0, 0, 1, 0]^T\end{aligned}$$

$$j = 6$$

$$\begin{aligned}\frac{\partial \dot{\mathbf{q}}}{\partial \dot{q}_6} &= \frac{\partial}{\partial \dot{q}_6} [\dot{x}_p, \dot{y}_p, \dot{z}_p, \dot{\theta}_p, \dot{\psi}_p, \dot{\phi}_p]^T = \frac{\partial}{\partial \dot{x}_p} [\dot{x}_p, \dot{y}_p, \dot{z}_p, \dot{\theta}_p, \dot{\psi}_p, \dot{\phi}_p]^T \\ \frac{\partial \dot{\mathbf{q}}}{\partial \dot{q}_6} &= [0, 0, 0, 0, 0, 1]^T\end{aligned}$$

Por lo tanto, se hace notar que al derivar el término $\frac{\partial \dot{\mathbf{q}}}{\partial \dot{q}_j}$ respecto al tiempo, se tiene:

$$\frac{d}{dt} \left(\frac{\partial \dot{\mathbf{q}}}{\partial \dot{q}_j} \right) = \mathbf{0}$$

Finalmente, tomando la ecuación (3.41) y derivando respecto al tiempo, se tiene:

$$\frac{d}{dt} \left(\frac{\partial L}{\partial \dot{q}_j} \right) = \frac{d}{dt} \left(\sum_{i=1}^6 \left(\frac{\partial L_{1i}}{\partial \dot{q}_j} + \frac{\partial L_{2i}}{\partial \dot{q}_j} \right) + \frac{\partial L_p}{\partial \dot{q}_j} + \frac{\partial L_c}{\partial \dot{q}_j} \right) \quad (3.56)$$

El desarrollo de la derivada con respecto al tiempo de cada término se muestra a continuación:

Desarrollando $\frac{d}{dt} \left(\frac{\partial L_{1i}}{\partial \dot{q}_j} \right)$

Derivando respecto al tiempo a la ec. (3.45) y agrupando, se tiene:

$$\begin{aligned}\frac{d}{dt} \left(\frac{\partial L_{1i}}{\partial \dot{q}_j} \right) &= \frac{d}{dt} \left(\frac{\partial \dot{\mathbf{q}}^T}{\partial \dot{q}_j} \mathbf{N}_{1i} \dot{\mathbf{q}} \right) \\ &= \frac{d}{dt} \frac{\partial \dot{\mathbf{q}}^T}{\partial \dot{q}_j} \mathbf{N}_{1i} \dot{\mathbf{q}} + \frac{\partial \dot{\mathbf{q}}^T}{\partial \dot{q}_j} \frac{d\mathbf{N}_{1i}}{dt} \dot{\mathbf{q}} + \frac{\partial \dot{\mathbf{q}}^T}{\partial \dot{q}_j} \mathbf{N}_{1i} \frac{d\dot{\mathbf{q}}}{dt} \\ \frac{d}{dt} \left(\frac{\partial L_{1i}}{\partial \dot{q}_j} \right) &= \frac{\partial \dot{\mathbf{q}}^T}{\partial \dot{q}_j} \mathbf{N}_{1i} \ddot{\mathbf{q}} + \frac{\partial \dot{\mathbf{q}}^T}{\partial \dot{q}_j} \dot{\mathbf{N}}_{1i} \dot{\mathbf{q}}\end{aligned} \quad (3.57)$$

Finalmente, realizando cambios de variable a la ec. (3.57):

$$\frac{d}{dt} \left(\frac{\partial L_{1i}}{\partial \dot{q}_j} \right) = \mathbb{D}_{1ij} \ddot{\mathbf{q}} + \mathbb{V}_{1ij} \dot{\mathbf{q}} \quad (3.58)$$

Donde:

$$\begin{aligned}\mathbb{D}_{1ij} &= \frac{\partial \dot{\mathbf{q}}^T}{\partial \dot{q}_j} \mathbf{N}_{1i} \\ \mathbb{V}_{1ij} &= \frac{\partial \dot{\mathbf{q}}^T}{\partial \dot{q}_j} \dot{\mathbf{N}}_{1i}\end{aligned}\tag{3.59}$$

Además:

$$\begin{aligned}\dot{\mathbf{N}}_{1i} &= m_{1i} \left(\dot{\mathbf{M}}_{1i}^T \mathbf{M}_{1i} + \mathbf{M}_{1i}^T \dot{\mathbf{M}}_{1i} \right) \\ \mathbf{M}_{1i} &= \mathbf{i}_{2i}^0 \mathbf{k}_{1i}^T + \mathbf{i}_{2i}^0 \dot{\mathbf{k}}_{1i}^T \\ \mathbf{i}_{2i}^0 &= \mathbf{0} \\ \mathbf{k}_{1i}^T &= \frac{1}{V_{1i}} [V_{2i}, V_{3i}, V_{4i}, V_{5i}, V_{6i}, V_{7i}] \\ \dot{\mathbf{k}}_{1i}^T &= \frac{d}{dt} \mathbf{k}_{1i}^T\end{aligned}$$

Desarrollando $\frac{d}{dt} \left(\frac{\partial L_{2i}}{\partial \dot{q}_j} \right)$

Derivando respecto al tiempo a la ec. (3.48) y agrupando, se tiene:

$$\begin{aligned}\frac{d}{dt} \left(\frac{\partial L_{2i}}{\partial \dot{q}_j} \right) &= \frac{d}{dt} \left(\frac{\partial \dot{\mathbf{q}}^T}{\partial \dot{q}_j} \mathbf{N}_{2i} \dot{\mathbf{q}} \right) \\ &= \frac{d}{dt} \frac{\partial \dot{\mathbf{q}}^T}{\partial \dot{q}_j} \mathbf{N}_{2i} \dot{\mathbf{q}} + \frac{\partial \dot{\mathbf{q}}^T}{\partial \dot{q}_j} \frac{d\mathbf{N}_{2i}}{dt} \dot{\mathbf{q}} + \frac{\partial \dot{\mathbf{q}}^T}{\partial \dot{q}_j} \mathbf{N}_{2i} \frac{d\dot{\mathbf{q}}}{dt} \\ \frac{d}{dt} \left(\frac{\partial L_{2i}}{\partial \dot{q}_j} \right) &= \frac{\partial \dot{\mathbf{q}}^T}{\partial \dot{q}_j} \mathbf{N}_{2i} \ddot{\mathbf{q}} + \frac{\partial \dot{\mathbf{q}}^T}{\partial \dot{q}_j} \dot{\mathbf{N}}_{2i} \dot{\mathbf{q}}\end{aligned}\tag{3.60}$$

Finalmente, realizando cambios de variable a la ec. (3.60):

$$\frac{d}{dt} \left(\frac{\partial L_{2i}}{\partial \dot{q}_j} \right) = \mathbb{D}_{2ij} \ddot{\mathbf{q}} + \mathbb{V}_{2ij} \dot{\mathbf{q}}\tag{3.61}$$

Donde:

$$\begin{aligned}\mathbb{D}_{2ij} &= \frac{\partial \dot{\mathbf{q}}^T}{\partial \dot{q}_j} \mathbf{N}_{2i} \\ \mathbb{V}_{2ij} &= \frac{\partial \dot{\mathbf{q}}^T}{\partial \dot{q}_j} \dot{\mathbf{N}}_{2i}\end{aligned}\tag{3.62}$$

Además:

$$\begin{aligned}
 \mathbf{M}_{2i} &= \mathbf{i}_{2i}^0 \mathbf{k}_{1i}^T + \mathbf{k}_{2i} \mathbf{k}_{4i}^T + \mathbf{k}_{3i} \mathbf{k}_{5i}^T \\
 \mathbf{M}_{3i} &= \mathbf{j}_{5i}^0 \mathbf{k}_{4i}^T + \mathbf{k}_{6i}^0 \mathbf{k}_{5i}^T \\
 \mathbf{J}_{G2i}^0 &= \mathbf{R}_{7i}^0 \mathbf{J}_{G2i}^7 \mathbf{R}_{7i}^{0T} \\
 \mathbf{k}_{6i}^0 &= \mathbf{R}_{6i}^0 \mathbf{J}_{6i}^6 \\
 \mathbf{k}_{2i} &= \mathbf{j}_{5i}^0 \times \mathbf{r}_{G2i'}^0 \\
 \mathbf{k}_{3i} &= \mathbf{k}_{6i}^0 \times \mathbf{r}_{G2i'}^0 \\
 \mathbf{k}_{4i}^T &= \frac{1}{V_{8i}} [E_{1i}, E_{2i}, E_{3i}, E_{4i}, E_{5i}, E_{6i}] \\
 \mathbf{k}_{5i}^T &= \frac{1}{V_{16i}} [E_{7i}, E_{8i}, E_{9i}, E_{10i}, E_{11i}, E_{12i}] \\
 \mathbf{j}_{5i}^0 &= \mathbf{R}_{5i}^0 \mathbf{J}_{5i}^5 \\
 \mathbf{r}_{G2i'}^0 &= \mathbf{R}_{7i}^0 \mathbf{r}_{G2i'}^7 \\
 \mathbf{R}_{5i}^0 &= \mathbf{R}_z(\gamma_{10i}) \mathbf{R}_y(\beta_{21i}) \\
 \mathbf{R}_{6i}^0 &= \mathbf{R}_z(\gamma_{10i}) \mathbf{R}_y(\beta_{21i}) \mathbf{R}_y(\psi_{65i}) \\
 \mathbf{R}_{7i}^0 &= \mathbf{R}_z(\gamma_{10i}) \mathbf{R}_y(\beta_{21i}) \mathbf{R}_y(\psi_{65i}) \mathbf{R}_z(\phi_{76i})
 \end{aligned}$$

Derivando:

$$\begin{aligned}
 \dot{\mathbf{N}}_{2i} &= m_{2i} \left(\dot{\mathbf{M}}_{2i}^T \mathbf{M}_{2i} + \mathbf{M}_{2i}^T \dot{\mathbf{M}}_{2i} \right) + \left(\dot{\mathbf{M}}_{3i}^T \mathbf{J}_{G2i}^0 \mathbf{M}_{3i} + \mathbf{M}_{3i}^T \dot{\mathbf{J}}_{G2i}^0 \mathbf{M}_{3i} + \mathbf{M}_{3i}^T \mathbf{J}_{G2i}^0 \dot{\mathbf{M}}_{3i} \right) \\
 \dot{\mathbf{M}}_{2i} &= \dot{\mathbf{i}}_{2i}^0 \mathbf{k}_{1i}^T + \dot{\mathbf{k}}_{2i} \mathbf{k}_{4i}^T + \dot{\mathbf{k}}_{3i} \mathbf{k}_{5i}^T \\
 \dot{\mathbf{M}}_{3i} &= \dot{\mathbf{j}}_{5i}^0 \mathbf{k}_{4i}^T + \dot{\mathbf{k}}_{6i}^0 \mathbf{k}_{5i}^T \\
 \dot{\mathbf{J}}_{G2i}^0 &= \dot{\mathbf{R}}_{7i}^0 \mathbf{J}_{G2i}^7 \mathbf{R}_{7i}^{0T} + \mathbf{R}_{7i}^0 \mathbf{J}_{G2i}^7 \dot{\mathbf{R}}_{7i}^{0T} \\
 \dot{\mathbf{k}}_{2i} &= \dot{\mathbf{j}}_{5i}^0 \times \mathbf{r}_{G2i'}^0 + \mathbf{j}_{5i}^0 \times \dot{\mathbf{r}}_{G2i'}^0 \\
 \dot{\mathbf{k}}_{3i} &= \dot{\mathbf{k}}_{6i}^0 \times \mathbf{r}_{G2i'}^0 + \mathbf{k}_{6i}^0 \times \dot{\mathbf{r}}_{G2i'}^0 \\
 \dot{\mathbf{k}}_{4i}^T &= \frac{d}{dt} \mathbf{k}_{4i}^T \\
 \dot{\mathbf{k}}_{5i}^T &= \frac{d}{dt} \mathbf{k}_{5i}^T
 \end{aligned}$$

A su vez:

$$\begin{aligned}
 \dot{\mathbf{r}}_{G2i'}^0 &= \dot{\mathbf{R}}_{7i}^0 \mathbf{r}_{G2i'}^7 \\
 \dot{\mathbf{k}}_{6i}^0 &= \dot{\mathbf{R}}_{6i}^0 \mathbf{J}_{6i}^6 \\
 \dot{\mathbf{R}}_{6i}^0 &= \mathbf{R}_{5i}^0 \dot{\mathbf{R}}_y(\psi_{65i}) \\
 &= \mathbf{R}_{5i}^0 \mathbf{B}_y(\psi_{65i}) \dot{\psi}_{65i} \\
 \dot{\mathbf{R}}_{7i}^0 &= \mathbf{R}_{5i}^0 \dot{\mathbf{R}}_y(\psi_{65i}) \mathbf{R}_z(\phi_{76i}) + \mathbf{R}_{5i}^0 \mathbf{R}_y(\psi_{65i}) \dot{\mathbf{R}}_z(\phi_{76i}) \\
 &= \mathbf{R}_{5i}^0 \mathbf{B}_y(\psi_{65i}) \mathbf{R}_z(\phi_{76i}) \dot{\psi}_{65i} + \mathbf{R}_{5i}^0 \mathbf{R}_y(\psi_{65i}) \mathbf{B}_z(\phi_{76i}) \dot{\phi}_{76i}
 \end{aligned}$$

Donde $\dot{\mathbf{J}}_{5i}^5$, $\dot{\mathbf{r}}_{G2i'}^7$, $\dot{\mathbf{J}}_{6i}^6$ y $\dot{\mathbf{J}}_{5i}^5$ son iguales al vector cero, ya que dependen de valores constantes que no cambian respecto al tiempo. Por otra parte, $\dot{\mathbf{R}}_{5i}^0 = \mathbf{0}_{3 \times 3}$, ya que sus elementos también son constantes a través del tiempo.

Desarrollando $\frac{d}{dt} \left(\frac{\partial L_p}{\partial \dot{q}_j} \right)$

Derivando respecto al tiempo a la ec. (3.52) y agrupando, se tiene:

$$\begin{aligned} \frac{d}{dt} \left(\frac{\partial L_p}{\partial \dot{q}_j} \right) &= \frac{d}{dt} \left(\frac{\partial \dot{\mathbf{q}}^T}{\partial \dot{q}_j} \mathbf{N}_3 \dot{\mathbf{q}} \right) \\ &= \frac{d}{dt} \frac{\partial \dot{\mathbf{q}}^T}{\partial \dot{q}_j} \mathbf{N}_3 \dot{\mathbf{q}} + \frac{\partial \dot{\mathbf{q}}^T}{\partial \dot{q}_j} \frac{d\mathbf{N}_3}{dt} \dot{\mathbf{q}} + \frac{\partial \dot{\mathbf{q}}^T}{\partial \dot{q}_j} \mathbf{N}_3 \frac{d\dot{\mathbf{q}}}{dt} \\ \frac{d}{dt} \left(\frac{\partial L_p}{\partial \dot{q}_j} \right) &= \frac{\partial \dot{\mathbf{q}}^T}{\partial \dot{q}_j} \mathbf{N}_3 \ddot{\mathbf{q}} + \frac{\partial \dot{\mathbf{q}}^T}{\partial \dot{q}_j} \dot{\mathbf{N}}_3 \dot{\mathbf{q}} \end{aligned} \quad (3.63)$$

Finalmente, realizando cambios de variable a la ec. (3.63):

$$\frac{d}{dt} \left(\frac{\partial L_p}{\partial \dot{q}_j} \right) = \mathbb{D}_{3j} \ddot{\mathbf{q}} + \mathbb{V}_{3j} \dot{\mathbf{q}} \quad (3.64)$$

Donde:

$$\begin{aligned} \mathbb{D}_{3j} &= \frac{\partial \dot{\mathbf{q}}^T}{\partial \dot{q}_j} \mathbf{N}_3 \\ \mathbb{V}_{3j} &= \frac{\partial \dot{\mathbf{q}}^T}{\partial \dot{q}_j} \dot{\mathbf{N}}_3 \end{aligned} \quad (3.65)$$

Además:

$$\begin{aligned} \mathbf{M}_4 &= \begin{bmatrix} 1 & 0 & 0 & 0 & 0 & 0 \\ 0 & 1 & 0 & 0 & 0 & 0 \\ 0 & 0 & 1 & 0 & 0 & 0 \end{bmatrix} \\ \mathbf{M}_5 &= \mathbf{i}_0^0 \mathbf{k}_6^T + \mathbf{j}_{15}^0 \mathbf{k}_7^T + \mathbf{k}_{16}^0 \mathbf{k}_8^T \\ \mathbf{J}_p^0 &= \mathbf{R}_p^0 \mathbf{J}_p^{12} \mathbf{R}_p^{0T} \\ \mathbf{k}_6^T &= [0, 0, 0, 1, 0, 0] \\ \mathbf{k}_7^T &= [0, 0, 0, 0, 1, 0] \\ \mathbf{k}_8^T &= [0, 0, 0, 0, 0, 1] \\ \mathbf{i}_0^0 &= [1, 0, 0]^T \\ \mathbf{j}_{15}^0 &= \mathbf{R}_{15}^0 \mathbf{j}_{15i}^{15} \\ \mathbf{k}_{16}^0 &= \mathbf{R}_{16}^0 \mathbf{k}_{16i}^{16} \\ \mathbf{j}_{15i}^{15} &= [0, 1, 0]^T \\ \mathbf{k}_{16i}^{16} &= [0, 0, 1]^T \\ \mathbf{R}_{15}^0 &= \mathbf{R}_x(\theta_p) \\ \mathbf{R}_{16}^0 &= \mathbf{R}_x(\theta_p) \mathbf{R}_y(\psi_p) \end{aligned}$$

$$\mathbf{R}_p^0 = \mathbf{R}_x(\theta_p) \mathbf{R}_y(\psi_p) \mathbf{R}_z(\phi_p)$$

Derivando:

$$\begin{aligned} \dot{\mathbf{N}}_3 &= m_p \left(\dot{\mathbf{M}}_4^T \mathbf{M}_4 + \mathbf{M}_4^T \dot{\mathbf{M}}_4 \right) + \left(\dot{\mathbf{M}}_5^T \mathbf{J}_p^0 \mathbf{M}_5 + \mathbf{M}_5^T \dot{\mathbf{J}}_p^0 \mathbf{M}_5 + \mathbf{M}_5^T \mathbf{J}_p^0 \dot{\mathbf{M}}_5 \right) \\ &= \dot{\mathbf{M}}_5^T \mathbf{J}_p^0 \mathbf{M}_5 + \mathbf{M}_5^T \dot{\mathbf{J}}_p^0 \mathbf{M}_5 + \mathbf{M}_5^T \mathbf{J}_p^0 \dot{\mathbf{M}}_5 \\ \dot{\mathbf{M}}_4 &= \mathbf{0} \\ \dot{\mathbf{M}}_5 &= \dot{\mathbf{j}}_{15}^0 \mathbf{k}_7^T + \dot{\mathbf{k}}_{16}^0 \mathbf{k}_8^T \\ \dot{\mathbf{j}}_{15}^0 &= \dot{\mathbf{R}}_{15}^0 \mathbf{j}_{15i}^{15} \\ \dot{\mathbf{k}}_{16}^0 &= \dot{\mathbf{R}}_{16}^0 \mathbf{k}_{16}^{16} \\ \dot{\mathbf{R}}_{15i}^0 &= \mathbf{B}_x(\theta_p) \dot{\theta}_p \\ \dot{\mathbf{R}}_{16i}^0 &= \dot{\mathbf{R}}_x(\theta_p) \mathbf{R}_y(\psi_p) + \mathbf{R}_x(\theta_p) \dot{\mathbf{R}}_y(\psi_p) \\ &= \mathbf{B}_x(\theta_p) \mathbf{R}_y(\psi_p) \dot{\theta}_p + \mathbf{R}_x(\theta_p) \mathbf{B}_y(\psi_p) \dot{\psi}_p \\ \dot{\mathbf{R}}_p^0 &= \dot{\mathbf{R}}_x(\theta_p) \mathbf{R}_y(\psi_p) \mathbf{R}_z(\phi_p) + \mathbf{R}_x(\theta_p) \dot{\mathbf{R}}_y(\psi_p) \mathbf{R}_z(\phi_p) + \mathbf{R}_x(\theta_p) \mathbf{R}_y(\psi_p) \dot{\mathbf{R}}_z(\phi_p) \\ &= \mathbf{B}_x(\theta_p) \mathbf{R}_y(\psi_p) \mathbf{R}_z(\phi_p) \dot{\theta}_p + \mathbf{R}_x(\theta_p) \mathbf{B}_y(\psi_p) \mathbf{R}_z(\phi_p) \dot{\psi}_p + \mathbf{R}_x(\theta_p) \mathbf{R}_y(\psi_p) \mathbf{B}_z(\phi_p) \dot{\phi}_p \\ \dot{\mathbf{j}}_p^0 &= \dot{\mathbf{R}}_p^0 \mathbf{J}_p^{12} \mathbf{R}_p^{0T} + \mathbf{R}_p^0 \mathbf{J}_p^{12} \dot{\mathbf{R}}_p^{0T} \end{aligned}$$

Desarrollando $\frac{d}{dt} \left(\frac{\partial L_c}{\partial \dot{q}_j} \right)$

Derivando respecto al tiempo a la ec. (3.55) y agrupando, se tiene:

$$\begin{aligned} \frac{d}{dt} \left(\frac{\partial L_c}{\partial \dot{q}_j} \right) &= \frac{d}{dt} \left(\frac{\partial \dot{\mathbf{q}}^T}{\partial \dot{q}_j} \mathbf{N}_4 \dot{\mathbf{q}} \right) \\ &= \frac{d}{dt} \frac{\partial \dot{\mathbf{q}}^T}{\partial \dot{q}_j} \mathbf{N}_4 \dot{\mathbf{q}} + \frac{\partial \dot{\mathbf{q}}^T}{\partial \dot{q}_j} \frac{d \mathbf{N}_4}{dt} \dot{\mathbf{q}} + \frac{\partial \dot{\mathbf{q}}^T}{\partial \dot{q}_j} \mathbf{N}_4 \frac{d \dot{\mathbf{q}}}{dt} \\ \frac{d}{dt} \left(\frac{\partial L_c}{\partial \dot{q}_j} \right) &= \frac{\partial \dot{\mathbf{q}}^T}{\partial \dot{q}_j} \mathbf{N}_4 \ddot{\mathbf{q}} + \frac{\partial \dot{\mathbf{q}}^T}{\partial \dot{q}_j} \dot{\mathbf{N}}_4 \dot{\mathbf{q}} \end{aligned} \quad (3.66)$$

Finalmente, realizando cambios de variable a la ec. (3.66):

$$\frac{d}{dt} \left(\frac{\partial L_c}{\partial \dot{q}_j} \right) = \mathbb{D}_{4j} \ddot{\mathbf{q}} + \mathbb{V}_{4j} \dot{\mathbf{q}} \quad (3.67)$$

Donde:

$$\begin{aligned} \mathbb{D}_{4j} &= \frac{\partial \dot{\mathbf{q}}^T}{\partial \dot{q}_j} \mathbf{N}_4 \\ \mathbb{V}_{4j} &= \frac{\partial \dot{\mathbf{q}}^T}{\partial \dot{q}_j} \dot{\mathbf{N}}_4 \end{aligned} \quad (3.68)$$

Además:

$$\begin{aligned}
 \mathbf{M}_6 &= \mathbf{M}_4 + \mathbf{k}_9 \mathbf{k}_6^T + \mathbf{k}_{10} \mathbf{k}_7^T + \mathbf{k}_{11} \mathbf{k}_8^T \\
 \mathbf{J}_{Gc}^0 &= \mathbf{R}_p^0 \mathbf{J}_{Gc}^p \mathbf{R}_p^{0T} \\
 \mathbf{k}_9 &= \mathbf{i}_0^0 \times \mathbf{r}_{Gc'}^0 \\
 \mathbf{k}_{10} &= \mathbf{j}_{15}^0 \times \mathbf{r}_{Gc'}^0 \\
 \mathbf{k}_{11} &= \mathbf{k}_{16}^0 \times \mathbf{r}_{Gc'}^0 \\
 \mathbf{r}_{Gc'}^0 &= \mathbf{R}_p^0 \mathbf{r}_{Gc}^p \\
 \mathbf{r}_{Gc}^p &= [x_{Gc}, y_{Gc}, z_{Gc}]^T
 \end{aligned}$$

Derivando:

$$\begin{aligned}
 \dot{N}_4 &= m_c (\dot{\mathbf{M}}_6^T \mathbf{M}_6 + \mathbf{M}_6^T \dot{\mathbf{M}}_6) + (\dot{\mathbf{M}}_5^T \mathbf{J}_{Gc}^0 \mathbf{M}_5 + \mathbf{M}_5^T \dot{\mathbf{J}}_{Gc}^0 \mathbf{M}_5 + \mathbf{M}_5^T \mathbf{J}_{Gc}^0 \dot{\mathbf{M}}_5) \\
 \dot{\mathbf{M}}_6 &= \dot{\mathbf{M}}_4 + \dot{\mathbf{k}}_9 \mathbf{k}_6^T + \mathbf{k}_9 \dot{\mathbf{k}}_6^T + \dot{\mathbf{k}}_{10} \mathbf{k}_7^T + \mathbf{k}_{10} \dot{\mathbf{k}}_7^T + \dot{\mathbf{k}}_{11} \mathbf{k}_8^T + \mathbf{k}_{11} \dot{\mathbf{k}}_8^T \\
 \dot{\mathbf{k}}_9 &= \dot{\mathbf{i}}_0^0 \times \mathbf{r}_{Gc'}^0 + \mathbf{i}_0^0 \times \dot{\mathbf{r}}_{Gc'}^0 \\
 \dot{\mathbf{k}}_{10} &= \dot{\mathbf{j}}_{15}^0 \times \mathbf{r}_{Gc'}^0 + \mathbf{j}_{15}^0 \times \dot{\mathbf{r}}_{Gc'}^0 \\
 \dot{\mathbf{k}}_{11} &= \dot{\mathbf{k}}_{16}^0 \times \mathbf{r}_{Gc'}^0 + \mathbf{k}_{16}^0 \times \dot{\mathbf{r}}_{Gc'}^0 \\
 \dot{\mathbf{r}}_{Gc'}^0 &= \dot{\mathbf{R}}_p^0 \mathbf{r}_{Gc}^p + \mathbf{R}_p^0 \dot{\mathbf{r}}_{Gc}^p \\
 \dot{\mathbf{J}}_{Gc}^0 &= \dot{\mathbf{R}}_p^0 \mathbf{J}_{Gc}^p \mathbf{R}_p^{0T} + \mathbf{R}_p^0 \mathbf{J}_{Gc}^p \dot{\mathbf{R}}_p^{0T}
 \end{aligned}$$

3.3.2. Desarrollo del Segundo Término de la Ecuación de Lagrange

Tomando la ec. (3.40) y aplicando la derivada parcial con respecto a la variable de coordenadas generalizadas:

$$\frac{\partial L}{\partial q_j} = \sum_{i=1}^6 \left(\frac{\partial L_{1i}}{\partial q_j} + \frac{\partial L_{2i}}{\partial q_j} \right) + \frac{\partial L_p}{\partial q_j} + \frac{\partial L_c}{\partial q_j} \quad (3.69)$$

Desarrollando el término $\frac{\partial L_{1i}}{\partial q_j}$

L_{1i} se define como:

$$L_{1i} = \frac{1}{2} \dot{\mathbf{q}}^T \mathbf{N}_{1i} \dot{\mathbf{q}} + m_{1i} \mathbf{g}^T \mathbf{r}_{G1i}^0$$

Donde:

$$\begin{aligned}
 \mathbf{N}_{1i} &= m_{1i} \mathbf{M}_{1i}^T \mathbf{M}_{1i} \\
 \mathbf{M}_{1i} &= \mathbf{i}_{2i}^0 \mathbf{k}_{1i}^T \\
 \mathbf{i}_{2i}^0 &= \mathbf{R}_{2i}^0 \mathbf{i}_{2i}^2
 \end{aligned}$$

$$\begin{aligned}\mathbf{R}_{2i}^0 &= \mathbf{R}_z(\gamma_{10i}) \mathbf{R}_y(\beta_{21i}) \\ \mathbf{i}_{2i}^2 &= [1, 0, 0]^T \\ \mathbf{k}_{1i}^T &= \frac{1}{V_{1i}} [V_{2i}, V_{3i}, V_{4i}, V_{5i}, V_{6i}, V_{7i}]\end{aligned}$$

Derivando respecto a q_j :

$$\begin{aligned}\frac{\partial L_{1i}}{\partial q_j} &= \frac{1}{2} \left(\frac{\partial \dot{\mathbf{q}}^T}{\partial q_j} \mathbf{N}_{1i} \dot{\mathbf{q}} + \dot{\mathbf{q}}^T \frac{\partial \mathbf{N}_{1i}}{\partial q_j} \dot{\mathbf{q}} + \dot{\mathbf{q}}^T \mathbf{N}_{1i} \frac{\partial \dot{\mathbf{q}}}{\partial q_j} \right) + m_{1i} \mathbf{g}^T \frac{\partial \mathbf{r}_{G1i}^0}{\partial q_j} \\ \frac{\partial L_{1i}}{\partial q_j} &= \frac{1}{2} \dot{\mathbf{q}}^T \frac{\partial \mathbf{N}_{1i}}{\partial q_j} \dot{\mathbf{q}} + m_{1i} \mathbf{g}^T \frac{\partial \mathbf{r}_{G1i}^0}{\partial q_j}\end{aligned}$$

Renombrando:

$$\frac{\partial L_{1i}}{\partial q_j} = \mathbb{V}'_{1ij} \dot{\mathbf{q}} + \mathbb{C}_{1ij} \quad (3.70)$$

Donde:

$$\begin{aligned}\mathbb{V}'_{1ij} &= \frac{1}{2} \dot{\mathbf{q}}^T \frac{\partial \mathbf{N}_{1i}}{\partial q_j} \\ \mathbb{C}_{1ij} &= m_{1i} \mathbf{g}^T \frac{\partial \mathbf{r}_{G1i}^0}{\partial q_j}\end{aligned} \quad (3.71)$$

A su vez:

$$\begin{aligned}\frac{\partial \mathbf{N}_{1i}}{\partial q_j} &= m_{1i} \frac{\partial \mathbf{M}_{1i}^T}{\partial q_j} \mathbf{M}_{1i} + m_{1i} \mathbf{M}_{1i}^T \frac{\partial \mathbf{M}_{1i}}{\partial q_j} \\ \frac{\partial \mathbf{M}_{1i}}{\partial q_j} &= \mathbf{i}_{2i}^0 \frac{\partial \mathbf{k}_{1i}^T}{\partial q_j} \\ \mathbf{k}_{1i}^T &= \frac{1}{V_{1i}} [V_{2i}, V_{3i}, V_{4i}, V_{5i}, V_{6i}, V_{7i}]\end{aligned}$$

A continuación, se procederá a derivar los vectores \mathbf{k}_i (los cuales han sido resultado de la simplificación de algunas expresiones) respecto a q_j . A lo largo del procedimiento se presentarán dos tipos de vectores \mathbf{k}_i , aquellos que contienen tres y los que contienen seis elementos, siendo ambos funciones de los ángulos x_{32i} , ψ_{65i} , ϕ_{76i} . Con el fin de obtener las derivadas parciales de ambos vectores, se hará uso de la regla de la cadena. A continuación, se procederá a derivar los vectores de tres elementos:

$$\frac{\partial \mathbf{k}_m}{\partial q_j} = \frac{\partial \mathbf{k}_m}{\partial x_{32i}} \frac{\partial x_{32i}}{\partial q_j} + \frac{\partial \mathbf{k}_m}{\partial \psi_{65i}} \frac{\partial \psi_{65i}}{\partial q_j} + \frac{\partial \mathbf{k}_m}{\partial \phi_{76i}} \frac{\partial \phi_{76i}}{\partial q_j}$$

Agrupando de forma matricial, tenemos:

$$\begin{aligned} \frac{\partial \mathbf{k}_m}{\partial q_j} &= \mathbf{J}_{n,3 \times 3} \frac{\partial \boldsymbol{\theta}_i}{\partial q_j} \\ \frac{\partial \boldsymbol{\theta}_i}{\partial q_j} &= \begin{bmatrix} \frac{\partial x_{32i}}{\partial q_j} & \frac{\partial \psi_{65i}}{\partial q_j} & \frac{\partial \phi_{76i}}{\partial q_j} \end{bmatrix}^T \end{aligned} \quad (3.72)$$

Donde $\mathbf{J}_{n,3 \times 3}$ es una matriz de 3x3 y se obtiene factorizando los términos $\frac{\partial x_{32i}}{\partial q_j}$, $\frac{\partial \psi_{65i}}{\partial q_j}$, $\frac{\partial \phi_{76i}}{\partial q_j}$.

Para obtener las derivadas de los vectores de seis componentes, se hará uso de la regla de la cadena, tal como sigue:

$$\begin{aligned} \frac{\partial \mathbf{k}_m}{\partial q_j} &= \frac{\partial \mathbf{k}_m}{\partial x_{32i}} \frac{\partial x_{32i}}{\partial q_j} + \frac{\partial \mathbf{k}_m}{\partial \psi_{65i}} \frac{\partial \psi_{65i}}{\partial q_j} + \frac{\partial \mathbf{k}_m}{\partial \phi_{76i}} \frac{\partial \phi_{76i}}{\partial q_j} + \frac{\partial \mathbf{k}_m}{\partial q_j} \\ \frac{\partial \mathbf{k}_m}{\partial q_j} &= \mathbf{J}_{n,6 \times 3} \frac{\partial \boldsymbol{\theta}_i}{\partial q_j} + \frac{\partial \mathbf{k}_m}{\partial q_j} \end{aligned}$$

Donde $\mathbf{J}_{n,6 \times 3}$ es una matriz de 6x3, $\frac{\partial \boldsymbol{\theta}_i}{\partial q_j}$ es un vector de 3x1 y $\frac{\partial \mathbf{k}_m}{\partial q_j}$ es un vector de 6x1 y es la derivada parcial del vector \mathbf{k}_m respecto a x_p , y_p , z_p , θ_p , ψ_p y ϕ_p según corresponda para j (no confundir con $\frac{\partial \mathbf{k}_m}{\partial q_j}$ que es la derivada parcial completa del vector \mathbf{k}_m respecto a q_j):

$$\begin{aligned} \mathbf{J}_n &= \begin{bmatrix} \frac{\partial \mathbf{k}_m}{\partial x_{32i}} & \frac{\partial \mathbf{k}_m}{\partial \psi_{65i}} & \frac{\partial \mathbf{k}_m}{\partial \phi_{76i}} \end{bmatrix} \\ \frac{\partial \boldsymbol{\theta}_i}{\partial q_j} &= \begin{bmatrix} \frac{\partial x_{32i}}{\partial q_j} & \frac{\partial \psi_{65i}}{\partial q_j} & \frac{\partial \phi_{76i}}{\partial q_j} \end{bmatrix}^T \end{aligned}$$

A partir de estos resultados, como \mathbf{k}_{1i}^T es un vector de 6 componentes, tenemos que:

$$\begin{aligned} \frac{\partial \mathbf{k}_{1i}^T}{\partial q_j} &= \mathbf{J}_{1i} \frac{\partial \boldsymbol{\theta}_i}{\partial q_j} + \frac{\partial \mathbf{k}_{1i}}{\partial q_j} \\ \mathbf{J}_{1i} &= \begin{bmatrix} \frac{\partial \mathbf{k}_{1i}}{\partial x_{32i}} & \mathbf{0} & \mathbf{0} \end{bmatrix} \end{aligned} \quad (3.73)$$

$$\frac{\partial \mathbf{k}_{1i}}{\partial x_{32i}} = \frac{\partial}{\partial x_{32i}} \left(\frac{1}{V_{1i}} [V_{2i}, V_{3i}, V_{4i}, V_{5i}, V_{6i}, V_{7i}]^T \right)$$

$$\frac{\partial \mathbf{k}_{1i}}{\partial q_j} = \frac{\partial}{\partial q_j} \left(\frac{1}{V_{1i}} [V_{2i}, V_{3i}, V_{4i}, V_{5i}, V_{6i}, V_{7i}]^T \right)$$

Para obtener $\frac{\partial \mathbf{r}_{G1i}^0}{\partial q_j}$ se parte de la ec. 3.5:

$$\mathbf{r}_{G1i}^0 = \mathbf{r}_{32i}^0 + \mathbf{r}_{G1i'}^0 \quad (3.5)$$

$$\frac{\partial \mathbf{r}_{G1i}^0}{\partial q_j} = \frac{\partial \mathbf{r}_{32i}^0}{\partial q_j} + \frac{\partial \mathbf{r}_{G1i'}^0}{\partial q_j}$$

Sabemos que:

$$\mathbf{r}_{32i}^0 = x_{32i} \mathbf{i}_{2i}^0$$

$$\mathbf{r}_{G1i'}^0 = \mathbf{R}_{2i}^0 \mathbf{r}_{G1i'}^2$$

$$\mathbf{R}_{2i}^0 = \mathbf{R}_z(\gamma_{10i}) \mathbf{R}_y(\beta_{21i})$$

Luego entonces:

$$\frac{\partial \mathbf{r}_{G1i}^0}{\partial q_j} = \frac{\partial (x_{32i} \mathbf{i}_{2i}^0)}{\partial q_j}$$

$$\frac{\partial \mathbf{r}_{G1i}^0}{\partial q_j} = \mathbf{i}_{2i}^0 \frac{\partial x_{32i}}{\partial q_j} = \mathbf{R}_{2i}^0 \mathbf{i}_{2i}^2 \frac{\partial x_{32i}}{\partial q_j}$$

Escribiendo matricialmente la ecuación anterior:

$$\frac{\partial \mathbf{r}_{G1i}^0}{\partial q_j} = \mathbf{J}_{2i} \frac{\partial \theta_i}{\partial q_j} \quad (3.74)$$

Donde:

$$\mathbf{J}_{2i} = [\mathbf{R}_{2i}^0 \mathbf{i}_{2i}^2 \quad \mathbf{0} \quad \mathbf{0}]$$

El cálculo del término $\frac{\partial \theta_i}{\partial q_j}$ se muestra en el apéndice D (Desarrollo de la ecuación de lazo).

Desarrollando el término $\frac{\partial L_{2i}}{\partial q_j}$

L_{2i} se define como:

$$L_{2i} = \frac{1}{2} \dot{\mathbf{q}}^T \mathbf{N}_{2i} \dot{\mathbf{q}} + m_{2i} \mathbf{g}^T \mathbf{r}_{G2i}^0$$

Donde:

$$\begin{aligned} \mathbf{N}_{2i} &= m_{2i} \mathbf{M}_{2i}^T \mathbf{M}_{2i} + \mathbf{M}_{3i}^T \mathbf{J}_{G2i}^0 \mathbf{M}_{3i} \\ \mathbf{M}_{2i} &= \mathbf{I}_{2i}^0 \mathbf{k}_{1i}^T + \mathbf{k}_{2i} \mathbf{k}_{4i}^T + \mathbf{k}_{3i} \mathbf{k}_{5i}^T \\ \mathbf{M}_{3i} &= \mathbf{J}_{5i}^0 \mathbf{k}_{4i}^T + \mathbf{k}_{6i}^0 \mathbf{k}_{5i}^T \\ \mathbf{J}_{G2i}^0 &= \mathbf{R}_{7i}^0 \mathbf{J}_{G2i}^7 \mathbf{R}_{7i}^{0T} \\ \mathbf{k}_{1i}^T &= \frac{1}{V_{1i}} [V_{2i}, V_{3i}, V_{4i}, V_{5i}, V_{6i}, V_{7i}] \\ \mathbf{k}_{2i} &= \mathbf{J}_{5i}^0 \times \mathbf{r}_{G2i}^0 \\ \mathbf{k}_{3i} &= \mathbf{k}_{6i}^0 \times \mathbf{r}_{G2i}^0 \\ \mathbf{k}_{4i}^T &= \frac{1}{V_{8i}} [E_{1i}, E_{2i}, E_{3i}, E_{4i}, E_{5i}, E_{6i}] \\ \mathbf{k}_{5i}^T &= \frac{1}{V_{16i}} [E_{7i}, E_{8i}, E_{9i}, E_{10i}, E_{11i}, E_{12i}] \end{aligned}$$

Derivando respecto a q_j :

$$\begin{aligned} \frac{\partial L_{2i}}{\partial q_j} &= \frac{1}{2} \left(\frac{\partial \dot{\mathbf{q}}^T}{\partial q_j} \mathbf{N}_{2i} \dot{\mathbf{q}} + \dot{\mathbf{q}}^T \frac{\partial \mathbf{N}_{2i}}{\partial q_j} \dot{\mathbf{q}} + \dot{\mathbf{q}}^T \mathbf{N}_{2i} \frac{\partial \dot{\mathbf{q}}}{\partial q_j} \right) + m_{2i} \mathbf{g}^T \frac{\partial \mathbf{r}_{G2i}^0}{\partial q_j} \\ \frac{\partial L_{2i}}{\partial q_j} &= \frac{1}{2} \dot{\mathbf{q}}^T \frac{\partial \mathbf{N}_{2i}}{\partial q_j} \dot{\mathbf{q}} + m_{2i} \mathbf{g}^T \frac{\partial \mathbf{r}_{G2i}^0}{\partial q_j} \end{aligned}$$

Renombrando:

$$\frac{\partial L_{2i}}{\partial q_j} = \mathbb{V}'_{2ij} \dot{\mathbf{q}} + \mathbb{C}_{2ij} \tag{3.75}$$

Donde:

$$\begin{aligned} \mathbb{V}'_{2ij} &= \frac{1}{2} \dot{\mathbf{q}}^T \frac{\partial \mathbf{N}_{2i}}{\partial q_j} \\ \mathbb{C}_{2ij} &= m_{2i} \mathbf{g}^T \frac{\partial \mathbf{r}_{G2i}^0}{\partial q_j} \end{aligned} \tag{3.76}$$

A su vez:

$$\begin{aligned}\frac{\partial N_{2i}}{\partial q_j} &= \frac{\partial}{\partial q_j} (m_{2i} \mathbf{M}_{2i}^T \mathbf{M}_{2i}) + \frac{\partial}{\partial q_j} (\mathbf{M}_{3i}^T \mathbf{J}_{G2i}^0 \mathbf{M}_{3i}) \\ \frac{\partial N_{2i}}{\partial q_j} &= m_{2i} \left(\frac{\partial \mathbf{M}_{2i}^T}{\partial q_j} \mathbf{M}_{2i} + \mathbf{M}_{2i}^T \frac{\partial \mathbf{M}_{2i}}{\partial q_j} \right) + \left(\frac{\partial \mathbf{M}_{3i}^T}{\partial q_j} \mathbf{J}_{G2i}^0 \mathbf{M}_{3i} + \mathbf{M}_{3i} \frac{\partial \mathbf{J}_{G2i}^0}{\partial q_j} \mathbf{M}_{3i} + \mathbf{M}_{3i}^T \mathbf{J}_{G2i}^0 \frac{\partial \mathbf{M}_{3i}}{\partial q_j} \right) \\ \frac{\partial \mathbf{M}_{2i}^T}{\partial q_j} &= \frac{\partial}{\partial q_j} (i_{2i}^0 \mathbf{k}_{1i}^T + \mathbf{k}_{2i} \mathbf{k}_{4i}^T + \mathbf{k}_{3i} \mathbf{k}_{5i}^T) \\ \frac{\partial \mathbf{M}_{2i}^T}{\partial q_j} &= \left(\frac{\partial i_{2i}^0}{\partial q_j} \mathbf{k}_{1i}^T + i_{2i}^0 \frac{\partial \mathbf{k}_{1i}^T}{\partial q_j} + \frac{\partial \mathbf{k}_{2i}}{\partial q_j} \mathbf{k}_{4i}^T + \mathbf{k}_{2i} \frac{\partial \mathbf{k}_{4i}^T}{\partial q_j} + \frac{\partial \mathbf{k}_{3i}}{\partial q_j} \mathbf{k}_{5i}^T + \mathbf{k}_{3i} \frac{\partial \mathbf{k}_{5i}^T}{\partial q_j} \right)\end{aligned}$$

Por otra parte, observamos que i_{2i}^0 no depende de alguna de las coordenadas generalizadas, ya que:

$$\begin{aligned}i_{2i}^0 &= \mathbf{R}_{2i}^0 i_{2i}^2 \\ \mathbf{R}_{2i}^0 &= \mathbf{R}_z(\gamma_{10i}) \mathbf{R}_y(\beta_{21i}) \\ i_{2i}^2 &= [1, 0, 0]^T\end{aligned}$$

por lo tanto:

$$\frac{\partial \mathbf{M}_{2i}^T}{\partial q_j} = \left(i_{2i}^0 \frac{\partial \mathbf{k}_{1i}^T}{\partial q_j} + \frac{\partial \mathbf{k}_{2i}}{\partial q_j} \mathbf{k}_{4i}^T + \mathbf{k}_{2i} \frac{\partial \mathbf{k}_{4i}^T}{\partial q_j} + \frac{\partial \mathbf{k}_{3i}}{\partial q_j} \mathbf{k}_{5i}^T + \mathbf{k}_{3i} \frac{\partial \mathbf{k}_{5i}^T}{\partial q_j} \right)$$

Para obtener el término $\frac{\partial \mathbf{k}_{2i}}{\partial q_j}$, se sabe que:

$$\frac{\partial \mathbf{k}_{2i}}{\partial q_j} = \frac{\partial \mathbf{j}_{5i}^0}{\partial q_j} \times \mathbf{r}_{G2i'}^0 + \mathbf{j}_{5i}^0 \times \frac{\partial \mathbf{r}_{G2i'}^0}{\partial q_j}$$

Además, observamos que las siguientes variables no dependen de alguna de las coordenadas generalizadas:

$$\begin{aligned}\mathbf{j}_{5i}^0 &= \mathbf{R}_{5i}^0 \mathbf{j}_{5i}^5 \\ \mathbf{R}_{5i}^0 &= \mathbf{R}_z(\gamma_{10i}) \mathbf{R}_y(\beta_{21i}) \\ \mathbf{j}_{5i}^5 &= [0, 1, 0]^T\end{aligned}$$

Por lo tanto:

$$\frac{\partial \mathbf{k}_{2i}}{\partial q_j} = \mathbf{j}_{5i}^0 \times \frac{\partial \mathbf{r}_{G2i'}^0}{\partial q_j}$$

Además:

$$\begin{aligned}\mathbf{r}_{G2i'}^0 &= \mathbf{R}_{7i}^0 \mathbf{r}_{G2i'}^7 \\ \mathbf{R}_{7i}^0 &= \mathbf{R}_z(\gamma_{10i}) \mathbf{R}_y(\beta_{21i}) \mathbf{R}_y(\psi_{65i}) \mathbf{R}_z(\phi_{76i}) \\ \mathbf{r}_{G2i'}^7 &= [x_{G2i}, 0, 0]^T\end{aligned}$$

Luego entonces:

$$\begin{aligned}\frac{\partial \mathbf{k}_{2i}}{\partial q_j} &= \mathbf{j}_{5i}^0 \times \frac{\partial \mathbf{R}_{7i}^0 \mathbf{r}_{G2i'}^7}{\partial q_j} \\ \frac{\partial \mathbf{k}_{2i}}{\partial q_j} &= \mathbf{j}_{5i}^0 \times \frac{\partial}{\partial q_j} [\mathbf{R}_z(\gamma_{10i}) \mathbf{R}_y(\beta_{21i}) \mathbf{R}_y(\psi_{65i}) \mathbf{R}_z(\phi_{76i}) \mathbf{r}_{G2i'}^7]\end{aligned}$$

Desarrollando y simplificando, tenemos:

$$\begin{aligned}\frac{\partial \mathbf{k}_{2i}}{\partial q_j} &= \mathbf{j}_{5i}^0 \times [\mathbf{R}_z(\gamma_{10i}) \mathbf{R}_y(\beta_{21i}) \frac{\partial \mathbf{R}_y(\psi_{65i})}{\partial q_j} \mathbf{R}_z(\phi_{76i}) \mathbf{r}_{G2i'}^7 \\ &\quad + \mathbf{R}_z(\gamma_{10i}) \mathbf{R}_y(\beta_{21i}) \mathbf{R}_y(\psi_{65i}) \frac{\partial \mathbf{R}_z(\phi_{76i})}{\partial q_j} \mathbf{r}_{G2i'}^7] \\ \frac{\partial \mathbf{k}_{2i}}{\partial q_j} &= \mathbf{j}_{5i}^0 \times [\mathbf{R}_z(\gamma_{10i}) \mathbf{R}_y(\beta_{21i}) \frac{\partial \mathbf{R}_y(\psi_{65i})}{\partial \psi_{65i}} \frac{\partial \psi_{65i}}{\partial q_j} \mathbf{R}_z(\phi_{76i}) \mathbf{r}_{G2i'}^7 \\ &\quad + \mathbf{R}_z(\gamma_{10i}) \mathbf{R}_y(\beta_{21i}) \mathbf{R}_y(\psi_{65i}) \frac{\partial \mathbf{R}_z(\phi_{76i})}{\partial \phi_{76i}} \frac{\partial \phi_{76i}}{\partial q_j} \mathbf{r}_{G2i'}^7] \\ \frac{\partial \mathbf{k}_{2i}}{\partial q_j} &= \mathbf{j}_{5i}^0 \times [\mathbf{R}_z(\gamma_{10i}) \mathbf{R}_y(\beta_{21i}) \mathbf{B}_y(\psi_{65i}) \mathbf{R}_z(\phi_{76i}) \mathbf{r}_{G2i'}^7 \frac{\partial \psi_{65i}}{\partial q_j} \\ &\quad + \mathbf{R}_z(\gamma_{10i}) \mathbf{R}_y(\beta_{21i}) \mathbf{R}_y(\psi_{65i}) \mathbf{B}_z(\phi_{76i}) \mathbf{r}_{G2i'}^7 \frac{\partial \phi_{76i}}{\partial q_j}] \\ \frac{\partial \mathbf{k}_{2i}}{\partial q_j} &= [\mathbf{j}_{5i}^0 \times (\mathbf{R}_z(\gamma_{10i}) \mathbf{R}_y(\beta_{21i}) \mathbf{B}_y(\psi_{65i}) \mathbf{R}_z(\phi_{76i}) \mathbf{r}_{G2i'}^7)] \frac{\partial \psi_{65i}}{\partial q_j} \\ &\quad + [\mathbf{j}_{5i}^0 \times (\mathbf{R}_z(\gamma_{10i}) \mathbf{R}_y(\beta_{21i}) \mathbf{R}_y(\psi_{65i}) \mathbf{B}_z(\phi_{76i}) \mathbf{r}_{G2i'}^7)] \frac{\partial \phi_{76i}}{\partial q_j}\end{aligned}$$

Escribiendo matricialmente la ecuación anterior:

$$\frac{\partial \mathbf{k}_{2i}}{\partial q_j} = \mathbf{J}_{3i} \frac{\partial \boldsymbol{\theta}_i}{\partial q_j} \quad (3.77)$$

Donde:

$$\mathbf{J}_{2i} = [\mathbf{0} \quad \mathbf{j}_{5i}^0 \times \mathbf{R}_z(\gamma_{10i}) \mathbf{R}_y(\beta_{21i}) \mathbf{B}_y(\psi_{65i}) \mathbf{R}_z(\phi_{76i}) \mathbf{r}_{G2i'}^7 \quad \mathbf{j}_{5i}^0 \times \mathbf{R}_z(\gamma_{10i}) \mathbf{R}_y(\beta_{21i}) \mathbf{R}_y(\psi_{65i}) \mathbf{B}_z(\phi_{76i}) \mathbf{r}_{G2i'}^7]$$

Para obtener el término $\frac{\partial \mathbf{k}_{3i}}{\partial q_j}$, se tiene:

$$\frac{\partial \mathbf{k}_{3i}}{\partial q_j} = \frac{\partial \mathbf{k}_{6i}^0}{\partial q_j} \times \mathbf{r}_{G2i'}^0 + \mathbf{k}_{6i}^0 \times \frac{\partial \mathbf{r}_{G2i'}^0}{\partial q_j} \quad (3.78)$$

Donde:

$$\begin{aligned}\mathbf{k}_{6i}^0 &= \mathbf{R}_{6i}^0 \mathbf{j}_{6i}^6 \\ \mathbf{R}_{6i}^0 &= \mathbf{R}_z(\gamma_{10i}) \mathbf{R}_y(\beta_{21i}) \mathbf{R}_y(\psi_{65i}) \\ \mathbf{j}_{6i}^6 &= [0, 1, 0]^T\end{aligned}$$

Obteniendo $\frac{\partial \mathbf{k}_{6i}^0}{\partial q_j}$.

$$\begin{aligned}\frac{\partial \mathbf{k}_{6i}^0}{\partial q_j} &= \frac{\partial \mathbf{R}_{6i}^0 \mathbf{j}_{6i}^6}{\partial q_j} = \frac{\partial}{\partial q_j} [\mathbf{R}_z(\gamma_{10i}) \mathbf{R}_y(\beta_{21i}) \mathbf{R}_y(\psi_{65i}) \mathbf{j}_{6i}^6] \\ \frac{\partial \mathbf{k}_{6i}^0}{\partial q_j} &= \mathbf{R}_z(\gamma_{10i}) \mathbf{R}_y(\beta_{21i}) \frac{\partial \mathbf{R}_y(\psi_{65i})}{\partial q_j} \mathbf{j}_{6i}^6 \\ \frac{\partial \mathbf{k}_{6i}^0}{\partial q_j} &= \mathbf{R}_z(\gamma_{10i}) \mathbf{R}_y(\beta_{21i}) \frac{\partial \mathbf{R}_y(\psi_{65i})}{\partial \psi_{65i}} \frac{\partial \psi_{65i}}{\partial q_j} \mathbf{j}_{6i}^6 \\ \frac{\partial \mathbf{k}_{6i}^0}{\partial q_j} &= [\mathbf{R}_z(\gamma_{10i}) \mathbf{R}_y(\beta_{21i}) \mathbf{B}_y(\psi_{65i}) \mathbf{j}_{6i}^6] \frac{\partial \psi_{65i}}{\partial q_j}\end{aligned}$$

Sustituyendo este resultado en 3.78:

$$\begin{aligned}\frac{\partial \mathbf{k}_3}{\partial q_j} &= \frac{\partial \mathbf{k}_{6i}^0}{\partial q_j} \times \mathbf{r}_{G2i'}^0 + \mathbf{k}_{6i}^0 \times \frac{\partial \mathbf{r}_{G2i'}^0}{\partial q_j} \\ \frac{\partial \mathbf{k}_{3i}}{\partial q_j} &= [\mathbf{R}_z(\gamma_{10i}) \mathbf{R}_y(\beta_{21i}) \mathbf{B}_y(\psi_{65i}) \mathbf{j}_{6i}^6] \frac{\partial \psi_{65i}}{\partial q_j} \times \mathbf{r}_{G2i'}^0 + \mathbf{k}_{6i}^0 \\ &\quad \times \left[\mathbf{R}_z(\gamma_{10i}) \mathbf{R}_y(\beta_{21i}) \mathbf{B}_y(\psi_{65i}) \mathbf{R}_z(\phi_{76i}) \mathbf{r}_{G2i'}^7 \frac{\partial \psi_{65i}}{\partial q_j} \right. \\ &\quad \left. + \mathbf{R}_z(\gamma_{10i}) \mathbf{R}_y(\beta_{21i}) \mathbf{R}_y(\psi_{65i}) \mathbf{B}_z(\phi_{76i}) \mathbf{r}_{G2i'}^7 \frac{\partial \phi_{76i}}{\partial q_j} \right] \\ \frac{\partial \mathbf{k}_{3i}}{\partial q_j} &= [\mathbf{R}_z(\gamma_{10i}) \mathbf{R}_y(\beta_{21i}) \mathbf{B}_y(\psi_{65i}) \mathbf{j}_{6i}^6 \times \mathbf{r}_{G2i'}^0] \frac{\partial \psi_{65i}}{\partial q_j} \\ &\quad + [\mathbf{k}_{6i}^0 \times (\mathbf{R}_z(\gamma_{10i}) \mathbf{R}_y(\beta_{21i}) \mathbf{B}_y(\psi_{65i}) \mathbf{R}_z(\phi_{76i}) \mathbf{r}_{G2i'}^7)] \frac{\partial \psi_{65i}}{\partial q_j} \\ &\quad + [\mathbf{k}_{6i}^0 \times \mathbf{R}_z(\gamma_{10i}) \mathbf{R}_y(\beta_{21i}) \mathbf{R}_y(\psi_{65i}) \mathbf{B}_z(\phi_{76i}) \mathbf{r}_{G2i'}^7] \frac{\partial \phi_{76i}}{\partial q_j} \\ \frac{\partial \mathbf{k}_{3i}}{\partial q_j} &= [\mathbf{R}_z(\gamma_{10i}) \mathbf{R}_y(\beta_{21i}) \mathbf{B}_y(\psi_{65i}) \mathbf{j}_{6i}^6 \times \mathbf{r}_{G2i'}^0 + \mathbf{k}_{6i}^0 \\ &\quad \times (\mathbf{R}_z(\gamma_{10i}) \mathbf{R}_y(\beta_{21i}) \mathbf{B}_y(\psi_{65i}) \mathbf{R}_z(\phi_{76i}) \mathbf{r}_{G2i'}^7)] \frac{\partial \psi_{65i}}{\partial q_j} \\ &\quad + [\mathbf{k}_{6i}^0 \times \mathbf{R}_z(\gamma_{10i}) \mathbf{R}_y(\beta_{21i}) \mathbf{R}_y(\psi_{65i}) \mathbf{B}_z(\phi_{76i}) \mathbf{r}_{G2i'}^7] \frac{\partial \phi_{76i}}{\partial q_j}\end{aligned}$$

Escribiendo matricialmente la ecuación anterior:

$$\frac{\partial \mathbf{k}_{3i}}{\partial q_j} = \mathbf{J}_{4i} \frac{\partial \theta_i}{\partial q_j} \quad (3.79)$$

Donde:

$$\mathbf{J}_{4i} = \begin{bmatrix} \mathbf{0} \\ \mathbf{R}_z(\gamma_{10i}) \mathbf{R}_y(\beta_{21i}) \mathbf{B}_y(\psi_{65i}) \mathbf{j}_{6i}^6 \times \mathbf{r}_{G2i'}^0 + \mathbf{k}_{6i}^0 \times (\mathbf{R}_z(\gamma_{10i}) \mathbf{R}_y(\beta_{21i}) \mathbf{B}_y(\psi_{65i}) \mathbf{R}_z(\phi_{76i}) \mathbf{r}_{G2i'}^7) \\ \mathbf{k}_{6i}^0 \times \mathbf{R}_z(\gamma_{10i}) \mathbf{R}_y(\beta_{21i}) \mathbf{R}_y(\psi_{65i}) \mathbf{B}_z(\phi_{76i}) \mathbf{r}_{G2i'}^7 \end{bmatrix}^T$$

Desarrollando $\frac{\partial L_p}{\partial q_j}$

L_p se define como:

$$L_p = \frac{1}{2} \left(m_p (\mathbf{v}_{Gp}^0)^T \mathbf{v}_{Gp}^0 + (\boldsymbol{\omega}_p^0)^T J_{Gp} \boldsymbol{\omega}_p^0 \right) + m_p \mathbf{g}^T \mathbf{r}_{Gp}^0$$

Simplificando:

$$L_p = \frac{1}{2} \dot{\mathbf{q}}^T N_3 \dot{\mathbf{q}} + m_p \mathbf{g}^T \mathbf{r}_{Gp}^0$$

Donde:

$$N_3 = m_p \mathbf{M}_4^T \mathbf{M}_4 + \mathbf{M}_5^T J_{Gp}^0 \mathbf{M}_5$$

$$\mathbf{M}_4 = \begin{bmatrix} 1 & 0 & 0 & 0 & 0 & 0 \\ 0 & 1 & 0 & 0 & 0 & 0 \\ 0 & 0 & 1 & 0 & 0 & 0 \end{bmatrix}$$

$$\mathbf{M}_5 = \mathbf{i}_0^0 \mathbf{k}_6^T + \mathbf{j}_{15}^0 \mathbf{k}_7^T + \mathbf{k}_{16}^0 \mathbf{k}_8^T$$

$$J_{Gp}^0 = \mathbf{R}_p^0 J_{Gp}^p \mathbf{R}_p^{0T}$$

$$\mathbf{k}_6^T = [0, 0, 0, 1, 0, 0]$$

$$\mathbf{k}_7^T = [0, 0, 0, 0, 1, 0]$$

$$\mathbf{k}_8^T = [0, 0, 0, 0, 0, 1]$$

$$\mathbf{k}_{16}^0 = \mathbf{R}_{16}^0 \mathbf{k}_{16}^{16}$$

$$\mathbf{k}_{16i}^{16} = [0, 0, 1]^T$$

$$\mathbf{r}_{Gp}^0 = \mathbf{r}_p^0$$

$$\mathbf{r}_p^0 = [x_p, y_p, z_p]^T$$

$$\mathbf{R}_{16}^0 = \mathbf{R}_x(\theta_p) \mathbf{R}_y(\psi_p)$$

$$\mathbf{R}_p^0 = \mathbf{R}_x(\theta_p) \mathbf{R}_y(\psi_p) \mathbf{R}_z(\phi_p)$$

Derivando con respecto a q_j :

$$\frac{\partial L_p}{\partial q_j} = \frac{1}{2} \frac{\partial}{\partial q_j} (\dot{\mathbf{q}}^T N_3 \dot{\mathbf{q}}) + \frac{\partial L_p}{\partial q_j} (m_p \mathbf{g}^T \mathbf{r}_{Gp}^0)$$

$$\frac{\partial L_p}{\partial q_j} = \frac{1}{2} \dot{\mathbf{q}}^T \frac{\partial N_3}{\partial q_j} \dot{\mathbf{q}} + m_p \mathbf{g}^T \frac{\partial \mathbf{r}_{Gp}^0}{\partial q_j}$$

Renombrando:

$$\frac{\partial L_p}{\partial q_j} = \mathbb{V}'_{3j} \dot{\mathbf{q}} + \mathbb{C}_{3j} \quad (3.80)$$

Donde:

$$\begin{aligned}\mathbb{V}'_{3j} &= \frac{1}{2} \dot{\mathbf{q}}^T \frac{\partial \mathbf{N}_3}{\partial q_j} \\ \mathbb{C}_{3j} &= m_p \mathbf{g}^T \frac{\partial \mathbf{r}_{Gp}^0}{\partial q_j}\end{aligned}\tag{3.81}$$

A su vez:

$$\begin{aligned}\frac{\partial \mathbf{N}_3}{\partial q_j} &= \frac{\partial}{\partial q_j} (m_p \mathbf{M}_4^T \mathbf{M}_4) + \frac{\partial}{\partial q_j} (\mathbf{M}_5^T \mathbf{J}_{Gp}^0 \mathbf{M}_5) \\ \frac{\partial \mathbf{N}_3}{\partial q_j} &= m_p \left(\frac{\partial \mathbf{M}_4^T}{\partial q_j} \mathbf{M}_4 + \mathbf{M}_4^T \frac{\partial \mathbf{M}_4}{\partial q_j} \right) + \left(\frac{\partial \mathbf{M}_5^T}{\partial q_j} \mathbf{J}_{Gp}^0 \mathbf{M}_5 + \mathbf{M}_5^T \frac{\partial \mathbf{J}_{Gp}^0}{\partial q_j} \mathbf{M}_5 + \mathbf{M}_5^T \mathbf{J}_{Gp}^0 \frac{\partial \mathbf{M}_5}{\partial q_j} \right)\end{aligned}$$

Desarrollando cada derivada parcial:

$$\begin{aligned}\frac{\partial \mathbf{M}_4}{\partial q_j} &= \mathbf{0} \\ \frac{\partial \mathbf{J}_{Gp}^0}{\partial q_j} &= \frac{\partial}{\partial q_j} (\mathbf{R}_p^0 \mathbf{J}_{Gp}^p \mathbf{R}_p^{0T}) = \frac{\partial \mathbf{R}_p^0}{\partial q_j} \mathbf{J}_{Gp}^p \mathbf{R}_p^{0T} + \mathbf{R}_p^0 \mathbf{J}_{Gp}^p \frac{\partial \mathbf{R}_p^{0T}}{\partial q_j}\end{aligned}$$

Obteniendo $\frac{\partial \mathbf{R}_p^0}{\partial q_j}$:

$$\frac{\partial \mathbf{R}_p^0}{\partial q_j} = \frac{\partial \mathbf{R}_x(\theta_p)}{\partial q_j} \mathbf{R}_y(\psi_p) \mathbf{R}_z(\phi_p) + \mathbf{R}_x(\theta_p) \frac{\partial \mathbf{R}_y(\psi_p)}{\partial q_j} \mathbf{R}_z(\phi_p) + \mathbf{R}_x(\theta_p) \mathbf{R}_y(\psi_p) \frac{\partial \mathbf{R}_z(\phi_p)}{\partial q_j}$$

Donde:

$$\begin{aligned}\frac{\partial \mathbf{R}_x(\theta_p)}{\partial q_j} &= \frac{\partial \mathbf{R}_x(\theta_p)}{\partial \theta_p} \frac{\partial \theta_p}{\partial q_j} = \mathbf{B}_x(\theta_p) \frac{\partial \theta_p}{\partial q_j} \\ \frac{\partial \mathbf{R}_y(\psi_p)}{\partial q_j} &= \frac{\partial \mathbf{R}_y(\psi_p)}{\partial \psi_p} \frac{\partial \psi_p}{\partial q_j} = \mathbf{B}_y(\psi_p) \frac{\partial \psi_p}{\partial q_j} \\ \frac{\partial \mathbf{R}_z(\phi_p)}{\partial q_j} &= \frac{\partial \mathbf{R}_z(\phi_p)}{\partial \phi_p} \frac{\partial \phi_p}{\partial q_j} = \mathbf{B}_z(\phi_p) \frac{\partial \phi_p}{\partial q_j}\end{aligned}$$

Además:

$$\frac{\partial \mathbf{M}_5}{\partial q_j} = \mathbf{i}_0^0 \frac{\partial \mathbf{k}_6^T}{\partial q_j} + \mathbf{j}_{15}^0 \mathbf{k}_7^T + \mathbf{j}_{15}^0 \frac{\partial \mathbf{k}_7^T}{\partial q_j} + \frac{\partial \mathbf{k}_{16}^0}{\partial q_j} \mathbf{k}_8^T + \mathbf{k}_{16}^0 \frac{\partial \mathbf{k}_8^T}{\partial q_j}$$

Puesto que \mathbf{k}_6^T , \mathbf{k}_7^T y \mathbf{k}_8^T son vectores constantes, se tiene que:

$$\begin{aligned}\frac{\partial \mathbf{k}_6^T}{\partial q_j} &= \frac{\partial}{\partial q_j} [0, 0, 0, 1, 0, 0] = 0 \\ \frac{\partial \mathbf{k}_7^T}{\partial q_j} &= \frac{\partial}{\partial q_j} [0, 0, 0, 0, 1, 0] = 0 \\ \frac{\partial \mathbf{k}_8^T}{\partial q_j} &= \frac{\partial}{\partial q_j} [0, 0, 0, 0, 0, 1] = 0\end{aligned}$$

Obteniendo $\frac{\partial \mathbf{j}_{15}^0}{\partial q_j}$:

$$\begin{aligned}\frac{\partial \mathbf{j}_{15}^0}{\partial q_j} &= \frac{\partial \mathbf{R}_{15}^0}{\partial q_j} \mathbf{j}_{15}^{15} + \mathbf{R}_{15}^0 \frac{\partial \mathbf{j}_{15}^{15}}{\partial q_j} \\ \frac{\partial \mathbf{R}_{15}^0}{\partial q_j} &= \frac{\partial \mathbf{R}_x(\theta_p)}{\partial q_j} = \frac{\partial \mathbf{R}_x(\theta_p)}{\partial \theta_p} \frac{\partial \theta_p}{\partial q_j} = \mathbf{B}_x(\theta_p) \frac{\partial \theta_p}{\partial q_j} \\ \frac{\partial \mathbf{j}_{15}^{15}}{\partial q_j} &= 0\end{aligned}$$

Obteniendo $\frac{\partial \mathbf{k}_{16}^0}{\partial q_j}$:

$$\begin{aligned}\frac{\partial \mathbf{k}_{16}^0}{\partial q_j} &= \frac{\partial \mathbf{R}_{16}^0}{\partial q_j} \mathbf{k}_{16}^{16} + \mathbf{R}_{16}^0 \frac{\partial \mathbf{k}_{16}^{16}}{\partial q_j} \\ \frac{\partial \mathbf{R}_{16}^0}{\partial q_j} &= \frac{\partial \mathbf{R}_x(\theta_p)}{\partial q_j} \mathbf{R}_y(\psi_p) + \mathbf{R}_x(\theta_p) \frac{\partial \mathbf{R}_y(\psi_p)}{\partial q_j} \\ &= \frac{\partial \mathbf{R}_x(\theta_p)}{\partial \theta_p} \frac{\partial \theta_p}{\partial q_j} \mathbf{R}_y(\psi_p) + \mathbf{R}_x(\theta_p) \frac{\partial \mathbf{R}_y(\psi_p)}{\partial \psi_p} \frac{\partial \psi_p}{\partial q_j} \\ \frac{\partial \mathbf{R}_{16}^0}{\partial q_j} &= \mathbf{B}_x(\theta_p) \mathbf{R}_y(\psi_p) \frac{\partial \theta_p}{\partial q_j} + \mathbf{R}_x(\theta_p) \mathbf{B}_y(\psi_p) \frac{\partial \psi_p}{\partial q_j} \\ \frac{\partial \mathbf{k}_{16}^{16}}{\partial q_j} &= 0\end{aligned}$$

Por otra parte:

$$\frac{\partial \mathbf{r}_{Gp}^0}{\partial q_j} = \frac{\partial \mathbf{r}_p^0}{\partial q_j} = \frac{\partial}{\partial q_j} [x_p, y_p, z_p]^T$$

Desarrollando $\frac{\partial L_c}{\partial q_j}$

L_c se define como:

$$L_c = \frac{1}{2} (m_c (\mathbf{v}_{Gc}^0)^T \mathbf{v}_{Gc}^0 + (\boldsymbol{\omega}_c^0)^T \mathbf{J}_{Gc} \boldsymbol{\omega}_c^0) + m_c \mathbf{g}^T \mathbf{r}_{Gc}^0 \quad (3.82)$$

Simplificando:

$$L_c = \frac{1}{2} (\dot{\mathbf{q}}^T \mathbf{N}_4 \dot{\mathbf{q}}) + m_c \mathbf{g}^T \mathbf{r}_{Gc}^0$$

Donde:

$$\begin{aligned} \mathbf{N}_4 &= m_c \mathbf{M}_6^T \mathbf{M}_6 + \mathbf{M}_5^T \mathbf{J}_{Gc}^0 \mathbf{M}_5 \\ \mathbf{M}_6 &= \mathbf{M}_4 + \mathbf{k}_9 \mathbf{k}_6^T + \mathbf{k}_{10} \mathbf{k}_7^T + \mathbf{k}_{11} \mathbf{k}_8^T \\ \mathbf{J}_{Gc}^0 &= \mathbf{R}_p^0 \mathbf{J}_{Gc}^p \mathbf{R}_p^{0T} \\ \mathbf{k}_9 &= \mathbf{i}_0^0 \times \mathbf{r}_{Gc'}^0 \\ \mathbf{k}_{10} &= \mathbf{j}_{15}^0 \times \mathbf{r}_{Gc'}^0 \\ \mathbf{k}_{11} &= \mathbf{k}_{16}^0 \times \mathbf{r}_{Gc'}^0 \end{aligned}$$

Derivando con respecto a q_j :

$$\begin{aligned} \frac{\partial L_c}{\partial q_j} &= \frac{1}{2} \frac{\partial}{\partial q_j} (\dot{\mathbf{q}}^T \mathbf{N}_4 \dot{\mathbf{q}}) + \frac{\partial L_p}{\partial q_j} (m_p \mathbf{g}^T \mathbf{r}_{Gc}^0) \\ \frac{\partial L_c}{\partial q_j} &= \frac{1}{2} \dot{\mathbf{q}}^T \frac{\partial \mathbf{N}_4}{\partial q_j} \dot{\mathbf{q}} + m_p \mathbf{g}^T \frac{\partial \mathbf{r}_{Gc}^0}{\partial q_j} \end{aligned}$$

Finalmente:

$$\frac{\partial L_c}{\partial q_j} = \mathbb{V}'_{4j} \dot{\mathbf{q}} + \mathbb{C}_{4j} \quad (3.83)$$

Donde:

$$\begin{aligned} \mathbb{V}'_{4j} &= \frac{1}{2} \dot{\mathbf{q}}^T \frac{\partial \mathbf{N}_4}{\partial q_j} \\ \mathbb{C}_{4j} &= m_p \mathbf{g}^T \frac{\partial \mathbf{r}_{Gc}^0}{\partial q_j} \end{aligned} \quad (3.84)$$

A su vez:

$$\begin{aligned} \frac{\partial \mathbf{N}_4}{\partial q_j} &= \frac{\partial}{\partial q_j} (m_c \mathbf{M}_6^T \mathbf{M}_6) + \frac{\partial}{\partial q_j} (\mathbf{M}_5^T \mathbf{J}_{Gc}^0 \mathbf{M}_5) \\ \frac{\partial \mathbf{N}_4}{\partial q_j} &= m_c \left(\frac{\partial \mathbf{M}_6^T}{\partial q_j} \mathbf{M}_6 + \mathbf{M}_6^T \frac{\partial \mathbf{M}_6}{\partial q_j} \right) + \left(\frac{\partial \mathbf{M}_5^T}{\partial q_j} \mathbf{J}_{Gc}^0 \mathbf{M}_5 + \mathbf{M}_5^T \frac{\partial \mathbf{J}_{Gc}^0}{\partial q_j} \mathbf{M}_5 + \mathbf{M}_5^T \mathbf{J}_{Gc}^0 \frac{\partial \mathbf{M}_5}{\partial q_j} \right) \end{aligned}$$

Desarrollando cada derivada parcial:

$$\begin{aligned} \frac{\partial \mathbf{M}_6}{\partial q_j} &= \frac{\partial}{\partial q_j} (\mathbf{M}_4 + \mathbf{k}_9 \mathbf{k}_6^T + \mathbf{k}_{10} \mathbf{k}_7^T + \mathbf{k}_{11} \mathbf{k}_8^T) \\ \frac{\partial \mathbf{M}_6}{\partial q_j} &= \frac{\partial \mathbf{M}_4}{\partial q_j} + \frac{\partial \mathbf{k}_9}{\partial q_j} \mathbf{k}_6^T + \mathbf{k}_9 \frac{\partial \mathbf{k}_6^T}{\partial q_j} + \frac{\partial \mathbf{k}_{10}}{\partial q_j} \mathbf{k}_7^T + \mathbf{k}_{10} \frac{\partial \mathbf{k}_7^T}{\partial q_j} + \frac{\partial \mathbf{k}_{11}}{\partial q_j} \mathbf{k}_8^T + \mathbf{k}_{11} \frac{\partial \mathbf{k}_8^T}{\partial q_j} \end{aligned}$$

$$\frac{\partial \mathbf{M}_6}{\partial q_j} = \frac{\partial \mathbf{k}_9}{\partial q_j} \mathbf{k}_6^T + \frac{\partial \mathbf{k}_{10}}{\partial q_j} \mathbf{k}_7^T + \frac{\partial \mathbf{k}_{11}}{\partial q_j} \mathbf{k}_8^T$$

Obteniendo $\frac{\partial \mathbf{k}_9}{\partial q_j}$:

$$\begin{aligned} \frac{\partial \mathbf{k}_9}{\partial q_j} &= \frac{\partial}{\partial q_j} (\mathbf{i}_0^0 \times \mathbf{r}_{Gc'}^0) \\ \frac{\partial \mathbf{k}_9}{\partial q_j} &= \frac{\partial \mathbf{i}_0^0}{\partial q_j} \times \mathbf{r}_{Gc'}^0 + \mathbf{i}_0^0 \times \frac{\partial \mathbf{r}_{Gc'}^0}{\partial q_j} \end{aligned}$$

Obteniendo $\frac{\partial \mathbf{k}_{10}}{\partial q_j}$:

$$\begin{aligned} \frac{\partial \mathbf{k}_{10}}{\partial q_j} &= \frac{\partial}{\partial q_j} (\mathbf{j}_{15}^0 \times \mathbf{r}_{Gc'}^0) \\ \frac{\partial \mathbf{k}_{10}}{\partial q_j} &= \frac{\partial \mathbf{j}_{15}^0}{\partial q_j} \times \mathbf{r}_{Gc'}^0 + \mathbf{j}_{15}^0 \times \frac{\partial \mathbf{r}_{Gc'}^0}{\partial q_j} \end{aligned}$$

Obteniendo $\frac{\partial \mathbf{k}_{11}}{\partial q_j}$:

$$\begin{aligned} \frac{\partial \mathbf{k}_{11}}{\partial q_j} &= \frac{\partial}{\partial q_j} (\mathbf{k}_{16}^0 \times \mathbf{r}_{Gc'}^0) \\ \frac{\partial \mathbf{k}_{11}}{\partial q_j} &= \frac{\partial \mathbf{k}_{16}^0}{\partial q_j} \times \mathbf{r}_{Gc'}^0 + \mathbf{k}_{16}^0 \times \frac{\partial \mathbf{r}_{Gc'}^0}{\partial q_j} \end{aligned}$$

Por otra parte:

$$\begin{aligned} \frac{\partial \mathbf{r}_{Gc'}^0}{\partial q_j} &= \frac{\partial}{\partial q_j} (\mathbf{R}_p^0 \mathbf{r}_{Gc}^p) \\ \frac{\partial \mathbf{r}_{Gc'}^0}{\partial q_j} &= \left(\frac{\partial \mathbf{R}_p^0}{\partial q_j} \mathbf{r}_{Gc}^p + \mathbf{R}_p^0 \frac{\partial \mathbf{r}_{Gc}^p}{\partial q_j} \right) \end{aligned}$$

Además:

$$\begin{aligned} \frac{\partial \mathbf{r}_{Gc}^0}{\partial q_j} &= \frac{\partial}{\partial q_j} (\mathbf{r}_p^0 + \mathbf{r}_{Gc'}^0) \\ \frac{\partial \mathbf{r}_{Gc}^0}{\partial q_j} &= \frac{\partial \mathbf{r}_p^0}{\partial q_j} + \frac{\partial \mathbf{r}_{Gc'}^0}{\partial q_j} \end{aligned}$$

Finalmente:

$$\begin{aligned} \frac{\partial \mathbf{J}_{Gc}^0}{\partial q_j} &= \frac{\partial}{\partial q_j} (\mathbf{R}_p^0 \mathbf{J}_{Gc}^p \mathbf{R}_p^{0T}) \\ \frac{\partial \mathbf{J}_{Gc}^0}{\partial q_j} &= \frac{\partial \mathbf{R}_p^0}{\partial q_j} \mathbf{J}_{Gc}^p \mathbf{R}_p^{0T} + \mathbf{R}_p^0 \mathbf{J}_{Gc}^p \frac{\partial \mathbf{R}_p^{0T}}{\partial q_j} \end{aligned}$$

3.4. Fuerzas Generalizadas

La formulación de la ecuación de Lagrange considera el uso de fuerzas generalizadas contemplando las fuerzas aplicadas externamente, fuerzas y torques de actuadores, de modo que es necesario desarrollar estas expresiones para que sean compatibles con el Lagrangiano, y además sean consistentes con las restricciones mecánicas. Las fuerzas generalizadas se obtienen a partir de la expresión de trabajo virtual.

Primero, consideremos el caso en el cual los actuadores ejercen una fuerza o torque en las juntas y fuerzas y momentos externos son aplicados al efector final. Definamos $\mathbf{F} = [f_1 \ f_2 \ f_3 \ f_4 \ f_5 \ f_6]^T$ como un vector que representa el torque generado en las juntas y $\mathbf{F}_e = [\mathbf{f}_e \ \mathbf{n}_e]^T$, el vector de seis coordenadas de las fuerzas y momentos resultantes en el efector final. Por lo tanto, el trabajo virtual producido por estas fuerzas y momentos es:

$$\delta W = \sum_{i=1}^6 \mathbf{F}_i^T \delta \mathbf{R}_i + \mathbf{M}_i^T \delta \mathbf{Q}_i$$

Aplicado al robot, donde i, j representan el número de cadena y cuerpo respectivamente.

$$\begin{aligned} \delta W &= \sum_{i=1}^6 \sum_{j=1}^2 (\mathbf{f}_{ij}^T \delta \mathbf{r}_i + \mathbf{m}_{ij}^T \delta \mathbf{Q}_{ij}) + \mathbf{f}_{ext}^T \delta \mathbf{r}_{ext} + \mathbf{n}_{ext}^T \delta \mathbf{Q}_{ext} \\ &= \sum_{i=1}^6 \mathbf{f}_i^{0T} \delta \mathbf{r}_i^0 + \mathbf{f}_{ext}^T \delta \mathbf{r}_{ext} + \mathbf{n}_{ext}^T \delta \mathbf{Q}_{ext} \end{aligned} \quad (3.85)$$

Obteniendo los términos \mathbf{f}_i^0 ,

$$\begin{aligned} \mathbf{f}_i^0 &= \mathbf{R}_{2i}^0 (\mathbf{f}_i \ \mathbf{t}_{2i}^i) \\ \mathbf{R}_{2i}^0 &= \mathbf{R}_{z3} (\gamma_{10i}) \mathbf{R}_{z2} (\beta_{21i}) \end{aligned} \quad (3.86)$$

Las velocidades lineales se relacionan con los desplazamientos virtuales, esto es:

$$\delta \mathbf{r} = \frac{\delta \mathbf{v}}{\delta \dot{x}} \delta x$$

Se plantean los desplazamientos virtuales que están relacionados con las fuerzas externas.

$$\delta \mathbf{r}_i^0 = \frac{\delta \mathbf{v}_{32i}^0}{\delta \dot{x}_{32i}} \delta x_{32i} \quad (3.87)$$

Donde:

$$\begin{aligned} \mathbf{v}_{32i}^0 &= \dot{x}_{32i} \mathbf{i}_{2i}^0 \\ \mathbf{i}_{2i}^0 &= \mathbf{R}_{2i}^0 \mathbf{i}_{2i}^{2i} \end{aligned} \quad (3.88)$$

Sustituyendo la ec. 3.88 en 3.87:

$$\begin{aligned} \delta \mathbf{r}_i^0 &= \frac{\delta \mathbf{R}_{2i}^0 \mathbf{i}_{2i}^{2i} \dot{x}_{32i}}{\delta \dot{x}_{32i}} \delta x_{32i} \\ &= \mathbf{R}_{2i}^0 \mathbf{i}_{2i}^{2i} \delta x_{32i} \end{aligned} \quad (3.89)$$

De la ec. 3.85 tenemos:

$$\sum_{i=1}^6 \mathbf{f}_i^{0T} \delta \mathbf{r}_i^0 = \mathbf{f}_1^{0T} \delta \mathbf{r}_1^0 + \mathbf{f}_2^{0T} \delta \mathbf{r}_2^0 + \mathbf{f}_3^{0T} \delta \mathbf{r}_3^0 + \mathbf{f}_4^{0T} \delta \mathbf{r}_4^0 + \mathbf{f}_5^{0T} \delta \mathbf{r}_5^0 + \mathbf{f}_6^{0T} \delta \mathbf{r}_6^0 \quad (3.90)$$

Sustituyendo los términos de las ec. 3.86 y 3.89 en la ec. 3.90 se tiene:

$$\begin{aligned} \sum_{i=1}^6 \mathbf{f}_i^{0T} \delta \mathbf{r}_i^0 &= \sum_{i=1}^6 (\mathbf{R}_{2i}^0 \mathbf{f}_i \mathbf{i}_{2i}^{2i})^T (\mathbf{R}_{2i}^0 \mathbf{i}_{2i}^{2i} \delta x_{32i}) \\ &= \sum_{i=1}^6 \mathbf{f}_i (\mathbf{i}_{2i}^{2iT} \mathbf{R}_{2i}^{0T}) (\mathbf{R}_{2i}^0 \mathbf{i}_{2i}^{2i}) \delta x_{32i} \\ &= \sum_{i=1}^6 \mathbf{f}_i \mathbf{i}_{2i}^{2iT} \mathbf{i}_{2i}^{2i} \delta x_{32i} \\ &= \sum_{i=1}^6 \mathbf{f}_i \delta x_{32i} \\ \sum_{i=1}^6 \mathbf{f}_i^{0T} \delta \mathbf{r}_i^0 &= f_1 \delta x_{321} + f_2 \delta x_{322} + f_3 \delta x_{323} + f_4 \delta x_{324} + f_5 \delta x_{325} + f_6 \delta x_{326} \end{aligned} \quad (3.91)$$

Escribiendo matricialmente la ec. 3.91:

$$\sum_{i=1}^6 \mathbf{f}_i^{0T} \delta \mathbf{r}_i^0 = \mathbf{f}^T \delta \mathbf{R} \quad (3.92)$$

Donde:

$$\begin{aligned} \mathbf{f}^T &= [f_1 \quad f_2 \quad f_3 \quad f_4 \quad f_5 \quad f_6] \\ \delta \mathbf{R} &= [\delta r_{321} \quad \delta r_{322} \quad \delta r_{323} \quad \delta r_{324} \quad \delta r_{325} \quad \delta r_{326}]^T \end{aligned}$$

Ahora, con el fin de poner la ec. 3.92 en función de $\delta\mathbf{q}$, se tiene la ec. D.3:

$$\mathbf{J}_R \dot{\mathbf{R}} = \mathbf{J}_q \dot{\mathbf{q}} \quad (\text{D.3})$$

Dividiendo ambos lados de la ecuación anterior por δt y despejando $\delta\mathbf{R}$, tenemos:

$$\delta\mathbf{R} = \mathbf{J}_R^{-1} \mathbf{J}_q \delta\mathbf{q} \quad (3.93)$$

Finalmente, sustituyendo la ec 3.93 en 3.92:

$$\sum_{i=1}^6 \mathbf{f}_i^{0T} \delta\mathbf{r}_i^0 = \mathbf{f}^T \mathbf{J}_R^{-1} \mathbf{J}_q \delta\mathbf{q} \quad (3.94)$$

Para obtener el término $\delta\mathbf{r}_{ext}^0$, se tiene:

$$\begin{aligned} \mathbf{r}_{ext}^0 &= \mathbf{r}_p^0 + \mathbf{R}_p^0 \mathbf{r}_e^p \\ \mathbf{r}_p^0 &= [x_p \quad y_p \quad z_p]^T \\ \mathbf{r}_e^0 &= [x_e \quad y_e \quad z_e]^T \end{aligned}$$

Obteniendo ahora el cambio virtual en el vector \mathbf{r}_{ext}^0 :

$$\begin{aligned} \delta\mathbf{r}_e^0 &= \delta\mathbf{r}_p^0 + \delta\mathbf{R}_p^0 \mathbf{r}_e^p \\ &= \delta\mathbf{r}_p^0 + \left(\frac{\delta\mathbf{R}_p^0}{\delta\theta_p} \delta\theta_p + \frac{\delta\mathbf{R}_p^0}{\delta\psi_p} \delta\psi_p + \frac{\delta\mathbf{R}_p^0}{\delta\phi_p} \delta\phi_p \right) \mathbf{r}_e^p \\ &= \delta\mathbf{r}_p^0 + \frac{\delta\mathbf{R}_p^0}{\delta\theta_p} \mathbf{r}_e^p \delta\theta_p + \frac{\delta\mathbf{R}_p^0}{\delta\psi_p} \mathbf{r}_e^p \delta\psi_p + \frac{\delta\mathbf{R}_p^0}{\delta\phi_p} \mathbf{r}_e^p \delta\phi_p \end{aligned}$$

Escribiendo matricialmente la ecuación anterior:

$$\delta\mathbf{r}_{ext}^0 = \mathbf{J}_{26} \delta\mathbf{q} \quad (3.95)$$

Donde:

$$\begin{aligned} \mathbf{J}_{26} &= [\mathbf{I}_{3 \times 3} \quad \mathbf{J}_{26,1} \quad \mathbf{J}_{26,2} \quad \mathbf{J}_{26,3}] \\ \delta\mathbf{q} &= [\delta\mathbf{r}_p^0 \quad \delta\theta_p \quad \delta\psi_p \quad \delta\phi_p]^T \end{aligned}$$

$$J_{26,1} = \frac{\delta \mathbf{R}_p^0}{\delta \theta_p} \mathbf{r}_e^p$$

$$J_{26,2} = \frac{\delta \mathbf{R}_p^0}{\delta \psi_p} \mathbf{r}_e^p$$

$$J_{26,3} = \frac{\delta \mathbf{R}_p^0}{\delta \phi_p} \mathbf{r}_e^p$$

Para obtener el término $\delta \mathbf{Q}_{ext}^0$:

$$\delta \mathbf{Q}_{ext}^0 = \frac{\delta \boldsymbol{\omega}_{op}^0}{\delta \dot{\theta}} \delta \theta + \frac{\delta \boldsymbol{\omega}_{op}^0}{\delta \dot{\psi}} \delta \psi + \frac{\delta \boldsymbol{\omega}_{op}^0}{\delta \dot{\phi}} \delta \phi \quad (3.96)$$

Donde:

$$\boldsymbol{\omega}_p^0 = \boldsymbol{\omega}_\theta^0 + \boldsymbol{\omega}_\psi^0 + \boldsymbol{\omega}_\phi^0$$

$$\boldsymbol{\omega}_\theta^0 = \dot{\theta}_p \mathbf{i}_0^0$$

$$\boldsymbol{\omega}_\psi^0 = \dot{\psi}_p \mathbf{R}_{15}^0 \mathbf{j}_{15}^{15}$$

$$\boldsymbol{\omega}_\phi^0 = \dot{\phi}_p \mathbf{R}_{16}^0 \mathbf{k}_{16}^{16}$$

$$\mathbf{R}_{15}^0 = \mathbf{R}_x(\theta_p)$$

$$\mathbf{R}_{16}^0 = \mathbf{R}_x(\theta_p) \mathbf{R}_y(\psi_p)$$

Sustituyendo los términos anteriores en la ec. 3.96:

$$\begin{aligned} \delta \mathbf{Q}_{ext}^0 &= \frac{\delta}{\delta \dot{\theta}} (\dot{\theta}_p \mathbf{i}_0^0 + \dot{\psi}_p \mathbf{R}_{15}^0 \mathbf{j}_{15}^{15} + \dot{\phi}_p \mathbf{R}_{16}^0 \mathbf{k}_{16}^{16}) \delta \theta + \frac{\delta}{\delta \dot{\psi}} (\dot{\theta}_p \mathbf{i}_0^0 + \dot{\psi}_p \mathbf{R}_{15}^0 \mathbf{j}_{15}^{15} + \dot{\phi}_p \mathbf{R}_{16}^0 \mathbf{k}_{16}^{16}) \delta \psi \\ &+ \frac{\delta}{\delta \dot{\phi}} (\dot{\theta}_p \mathbf{i}_0^0 + \dot{\psi}_p \mathbf{R}_{15}^0 \mathbf{j}_{15}^{15} + \dot{\phi}_p \mathbf{R}_{16}^0 \mathbf{k}_{16}^{16}) \delta \phi \\ &= \mathbf{i}_0^0 \delta \theta + \mathbf{R}_{15}^0 \mathbf{j}_{15}^{15} \delta \psi + \mathbf{R}_{16}^0 \mathbf{k}_{16}^{16} \delta \phi \end{aligned}$$

Escribiendo matricialmente la ecuación anterior:

$$\delta \mathbf{Q}_{ext}^0 = \mathbf{J}_{27} \delta \mathbf{q} \quad (3.97)$$

Donde:

$$\mathbf{J}_{27} = [\mathbf{0} \quad \mathbf{0} \quad \mathbf{0} \quad J_{27,1} \quad J_{27,2} \quad J_{27,3}]$$

$$\delta \mathbf{q} = [\delta \mathbf{r}_p^0 \quad \delta \psi \quad \delta \theta \quad \delta \phi]^T$$

$$\begin{aligned} J_{27,1} &= \mathbf{i}_0^0 \\ J_{27,2} &= \mathbf{R}_{15}^0 \mathbf{j}_{15}^{15} \\ J_{27,3} &= \mathbf{R}_{16}^0 \mathbf{k}_{16}^{16} \end{aligned}$$

Por último, sustituyendo las ecuaciones 3.94, 3.95 y 3.97 en 3.85:

$$\begin{aligned} \delta W &= \sum_{i=1}^6 \mathbf{f}_i^{0T} \delta \mathbf{r}_i^0 + \mathbf{f}_{ext}^T \delta \mathbf{r}_{ext} + \mathbf{n}_{ext}^T \delta \mathbf{Q}_{ext} \\ &= \mathbf{f}^T \mathbf{J}_R^{-1} \mathbf{J}_q \delta \mathbf{q} + \mathbf{f}_{ext}^T \mathbf{J}_{26} \delta \mathbf{q} + \mathbf{n}_{ext}^T \mathbf{J}_{27} \delta \mathbf{q} \\ &= (\mathbf{f}^T \mathbf{J}_R^{-1} \mathbf{J}_q + \mathbf{f}_{ext}^T \mathbf{J}_{26} + \mathbf{n}_{ext}^T \mathbf{J}_{27}) \delta \mathbf{q} \\ &= \mathbf{Q}^T \delta \mathbf{q} \end{aligned} \tag{3.98}$$

Las fuerzas generalizadas obtenidas son:

$$\mathbf{Q}^T = \mathbf{f}^T \mathbf{J}_R^{-1} \mathbf{J}_q + \mathbf{f}_{ext}^T \mathbf{J}_{26} + \mathbf{n}_{ext}^T \mathbf{J}_{27}$$

3.5. Sustitución de los términos en la Ecuación de Lagrange

Por último, se tiene la ec 3.4:

$$\frac{d}{dt} \left(\frac{\partial L}{\partial \dot{q}_j} \right) - \frac{\partial L}{\partial q_j} = Q_j \tag{3.4}$$

Donde:

$$\begin{aligned} \frac{d}{dt} \left(\frac{\partial L}{\partial \dot{q}_j} \right) &= \frac{d}{dt} \left(\sum_{i=1}^6 \left(\frac{\partial L_{1i}}{\partial \dot{q}_j} + \frac{\partial L_{2i}}{\partial \dot{q}_j} \right) + \frac{\partial L_p}{\partial \dot{q}_j} + \frac{\partial L_c}{\partial \dot{q}_j} \right) \\ &= \sum_{i=1}^6 (\mathbb{D}_{1ij} \ddot{\mathbf{q}} + \mathbb{V}_{1ij} \dot{\mathbf{q}} + \mathbb{D}_{2ij} \ddot{\mathbf{q}} + \mathbb{V}_{2ij} \dot{\mathbf{q}}) + \mathbb{D}_{3j} \ddot{\mathbf{q}} + \mathbb{V}_{3j} \dot{\mathbf{q}} + \mathbb{D}_{4j} \ddot{\mathbf{q}} + \mathbb{V}_{4j} \dot{\mathbf{q}} \\ &= \left[\sum_{i=1}^6 (\mathbb{D}_{1ij} + \mathbb{D}_{2ij}) + \mathbb{D}_{3j} + \mathbb{D}_{4j} \right] \ddot{\mathbf{q}} + \left[\sum_{i=1}^6 (\mathbb{V}_{1ij} + \mathbb{V}_{2ij}) + \mathbb{V}_{3j} + \mathbb{V}_{4j} \right] \dot{\mathbf{q}} \\ \frac{\partial L}{\partial q_j} &= \sum_{i=1}^6 \frac{\partial}{\partial q_j} (L_{1i} + L_{2i}) + \frac{\partial L_p}{\partial q_j} + \frac{\partial L_c}{\partial q_j} \\ &= \sum_{i=1}^6 (\mathbb{V}'_{1ij} \dot{\mathbf{q}} + \mathbb{C}_{1ij} + \mathbb{V}'_{2ij} \dot{\mathbf{q}} + \mathbb{C}_{2ij}) + \mathbb{V}'_{3j} \dot{\mathbf{q}} + \mathbb{C}_{3j} + \mathbb{V}'_{4j} \dot{\mathbf{q}} + \mathbb{C}_{4j} \end{aligned}$$

$$= \left[\sum_{i=1}^6 (\mathbb{V}'_{1ij} + \mathbb{V}'_{2ij}) + \mathbb{V}'_{3j} + \mathbb{V}'_{4j} \right] \dot{\mathbf{q}} + \left[\sum_{i=1}^6 (\mathbb{C}_{1ij} + \mathbb{C}_{2ij}) + \mathbb{C}_{3j} + \mathbb{C}_{4j} \right]$$

$$\mathbf{Q}^T = \mathbf{f}^T \mathbf{J}_R^{-1} \mathbf{J}_q + \mathbf{f}_{ext}^T \mathbf{J}_{26} + \mathbf{n}_{ext}^T \mathbf{J}_{27}$$

$$\mathbf{Q} = (\mathbf{J}_R^{-1} \mathbf{J}_q)^T \mathbf{f} + \mathbf{J}_{26}^T \mathbf{f}_{ext} + \mathbf{J}_{27}^T \mathbf{n}_{ext}$$

Sustituyendo en la ec. 3.4:

$$\left[\sum_{i=1}^6 (\mathbb{D}_{1ij} + \mathbb{D}_{2ij}) + \mathbb{D}_{3j} + \mathbb{D}_{4j} \right] \ddot{\mathbf{q}} + \left[\sum_{i=1}^6 (\mathbb{V}_{1ij} + \mathbb{V}_{2ij}) + \mathbb{V}_{3j} + \mathbb{V}_{4j} \right] \dot{\mathbf{q}} - \left[\sum_{i=1}^6 (\mathbb{V}'_{1ij} + \mathbb{V}'_{2ij}) + \mathbb{V}'_{3j} + \mathbb{V}'_{4j} \right] \dot{\mathbf{q}} - \left[\sum_{i=1}^6 (\mathbb{C}_{1ij} + \mathbb{C}_{2ij}) + \mathbb{C}_{3j} + \mathbb{C}_{4j} \right] = \mathbf{Q}_j$$

$$\left[\sum_{i=1}^6 (\mathbb{D}_{1ij} + \mathbb{D}_{2ij}) + \mathbb{D}_{3j} + \mathbb{D}_{4j} \right] \ddot{\mathbf{q}} + \left[\sum_{i=1}^6 (\mathbb{V}_{1ij} + \mathbb{V}_{2ij}) + \mathbb{V}_{3j} + \mathbb{V}_{4j} - \sum_{i=1}^6 (\mathbb{V}'_{1ij} + \mathbb{V}'_{2ij}) - \mathbb{V}'_{3j} - \mathbb{V}'_{4j} \right] \dot{\mathbf{q}} + \left[\sum_{i=1}^6 (-\mathbb{C}_{1ij} - \mathbb{C}_{2ij}) - \mathbb{C}_{3j} - \mathbb{C}_{4j} \right] = \mathbf{Q}_j$$

Finalmente:

$$\mathbb{D}_j \ddot{\mathbf{q}} + \mathbb{V}_j \dot{\mathbf{q}} + \mathbb{C}_j = \mathbf{Q}_j \quad (3.99)$$

Donde:

$$\mathbb{D}_j = \left[\sum_{i=1}^6 (\mathbb{D}_{1ij} + \mathbb{D}_{2ij}) + \mathbb{D}_{3j} + \mathbb{D}_{4j} \right]$$

$$\mathbb{V}_j = \left[\sum_{i=1}^6 (\mathbb{V}_{1ij} + \mathbb{V}_{2ij}) + \mathbb{V}_{3j} + \mathbb{V}_{4j} - \sum_{i=1}^6 (\mathbb{V}'_{1ij} + \mathbb{V}'_{2ij}) - \mathbb{V}'_{3j} - \mathbb{V}'_{4j} \right]$$

$$\mathbb{C}_j = \left[\sum_{i=1}^6 (-\mathbb{C}_{1ij} - \mathbb{C}_{2ij}) - \mathbb{C}_{3j} - \mathbb{C}_{4j} \right]$$

Escribiendo la ec. 3.99 seis veces, una para cada $j=1,2,3,4,5,6$, obtenemos seis ecuaciones escalares, las cuales se pueden ordenar de la siguiente forma:

$$\begin{bmatrix} \mathbb{D}_1 \\ \mathbb{D}_2 \\ \mathbb{D}_3 \\ \mathbb{D}_4 \\ \mathbb{D}_5 \\ \mathbb{D}_6 \end{bmatrix} \ddot{\mathbf{q}} + \begin{bmatrix} \mathbb{V}_1 \\ \mathbb{V}_2 \\ \mathbb{V}_3 \\ \mathbb{V}_4 \\ \mathbb{V}_5 \\ \mathbb{V}_6 \end{bmatrix} \dot{\mathbf{q}} + \begin{bmatrix} \mathbb{C}_1 \\ \mathbb{C}_2 \\ \mathbb{C}_3 \\ \mathbb{C}_4 \\ \mathbb{C}_5 \\ \mathbb{C}_6 \end{bmatrix} = \begin{bmatrix} \mathbf{Q}_1 \\ \mathbf{Q}_2 \\ \mathbf{Q}_3 \\ \mathbf{Q}_4 \\ \mathbf{Q}_5 \\ \mathbf{Q}_6 \end{bmatrix}$$

$$\mathbb{D}' \ddot{\mathbf{q}} + \mathbb{V}' \dot{\mathbf{q}} + \mathbb{C}' = \mathbf{Q}$$

$$\mathbb{D}' \ddot{\mathbf{q}} + \mathbb{V}' \dot{\mathbf{q}} + \mathbb{C}' = (\mathbf{J}_R^{-1} \mathbf{J}_q)^T \mathbf{f} + \mathbf{J}_{26}^T \mathbf{f}_{ext} + \mathbf{J}_{27}^T \mathbf{n}_{ext}$$

$$\mathbb{D}' \ddot{\mathbf{q}} + \mathbb{V}' \dot{\mathbf{q}} + \mathbb{C}' + (-\mathbf{J}_{26}^T \mathbf{f}_{ext} - \mathbf{J}_{27}^T \mathbf{n}_{ext}) = (\mathbf{J}_R^{-1} \mathbf{J}_q)^T \mathbf{f}$$

$$(\mathbf{J}_R^{-1} \mathbf{J}_q)^{-T} \mathbb{D}' \ddot{\mathbf{q}} + (\mathbf{J}_R^{-1} \mathbf{J}_q)^{-T} \mathbb{V}' \dot{\mathbf{q}} + (\mathbf{J}_R^{-1} \mathbf{J}_q)^{-T} \mathbb{C}' + (\mathbf{J}_R^{-1} \mathbf{J}_q)^{-T} (-\mathbf{J}_{26}^T \mathbf{f}_{ext} - \mathbf{J}_{27}^T \mathbf{n}_{ext}) = \mathbf{f}$$

Finalmente:

$$\mathbb{D} \ddot{\mathbf{q}} + \mathbb{V} \dot{\mathbf{q}} + \mathbb{C} + \mathbb{E} = \mathbf{f} \quad (3.100)$$

Donde:

$$\begin{aligned} \mathbb{D} &= (\mathbf{J}_R^{-1} \mathbf{J}_q)^{-T} \mathbb{D}' \\ \mathbb{V} &= (\mathbf{J}_R^{-1} \mathbf{J}_q)^{-T} \mathbb{V}' \\ \mathbb{C} &= (\mathbf{J}_R^{-1} \mathbf{J}_q)^{-T} \mathbb{C}' \\ \mathbb{E} &= (\mathbf{J}_R^{-1} \mathbf{J}_q)^{-T} (-\mathbf{J}_{26}^T \mathbf{f}_{ext} - \mathbf{J}_{27}^T \mathbf{n}_{ext}) \end{aligned}$$

Capítulo 4

Resultados

A continuación, se muestran los resultados del análisis cinemático y dinámico del robot paralelo para la trayectoria descrita en el Apéndice A.

4.1 Gráficas de Posición

Los parámetros del robot relacionados con la geometría están basados son similares a la estructura en la que se basó éste trabajo, y se presentan de la siguiente manera debido a que se repiten para cada una de las cadenas cinemáticas:

$$\begin{aligned}\gamma_{101} &= 0^\circ \\ \beta_{211} &= 30^\circ \\ b_{431} &= 0.127 \text{ m} \\ c_{541} &= 0.085 \text{ m} \\ a_{871} &= 0.800 \text{ m} \\ \gamma_{12111} &= 330^\circ \\ a_{13121} &= 350^\circ \\ \gamma_{14131} &= 210^\circ\end{aligned}$$

$$\begin{aligned}\gamma_{101} &= 0^\circ \\ \beta_{211} &= 30^\circ \\ b_{431} &= 0.127 \text{ m} \\ c_{541} &= 0.085 \text{ m} \\ a_{871} &= 0.800 \text{ m} \\ \gamma_{12111} &= 30^\circ \\ a_{13121} &= 350^\circ \\ \gamma_{14131} &= 150^\circ\end{aligned}$$

$$\begin{aligned}\gamma_{101} &= 120^\circ \\ \beta_{211} &= 30^\circ \\ b_{431} &= 0.127 \text{ m} \\ c_{541} &= 0.085 \text{ m} \\ a_{871} &= 0.800 \text{ m} \\ \gamma_{12111} &= 330^\circ \\ a_{13121} &= 350^\circ \\ \gamma_{14131} &= 90^\circ\end{aligned}$$

$$\begin{aligned}\gamma_{101} &= 120^\circ \\ \beta_{211} &= 30^\circ \\ b_{431} &= 0.127 \text{ m} \\ c_{541} &= 0.085 \text{ m} \\ a_{871} &= 0.800 \text{ m} \\ \gamma_{12111} &= 30^\circ \\ a_{13121} &= 350^\circ \\ \gamma_{14131} &= 30^\circ\end{aligned}$$

$$\begin{aligned}\gamma_{101} &= 240^\circ \\ \beta_{211} &= 30^\circ \\ b_{431} &= 0.127 \text{ m} \\ c_{541} &= 0.085 \text{ m} \\ a_{871} &= 0.800 \text{ m} \\ \gamma_{12111} &= 330^\circ \\ a_{13121} &= 350^\circ \\ \gamma_{14131} &= 330^\circ\end{aligned}$$

$$\begin{aligned}\gamma_{101} &= 240^\circ \\ \beta_{211} &= 30^\circ \\ b_{431} &= 0.127 \text{ m} \\ c_{541} &= 0.085 \text{ m} \\ a_{871} &= 0.800 \text{ m} \\ \gamma_{12111} &= 30^\circ \\ a_{13121} &= 350^\circ \\ \gamma_{14131} &= 270^\circ\end{aligned}$$

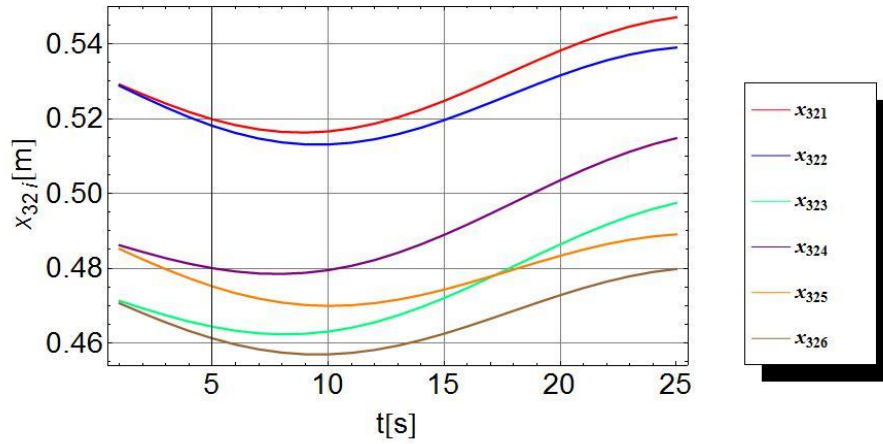

Fig. 4.1 Gráfica para x_{32i}

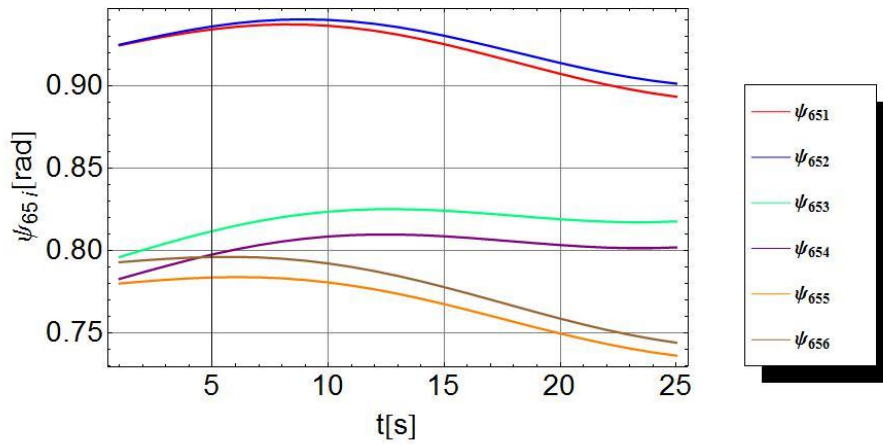

Fig. 4.2 Gráfica para ψ_{65i}

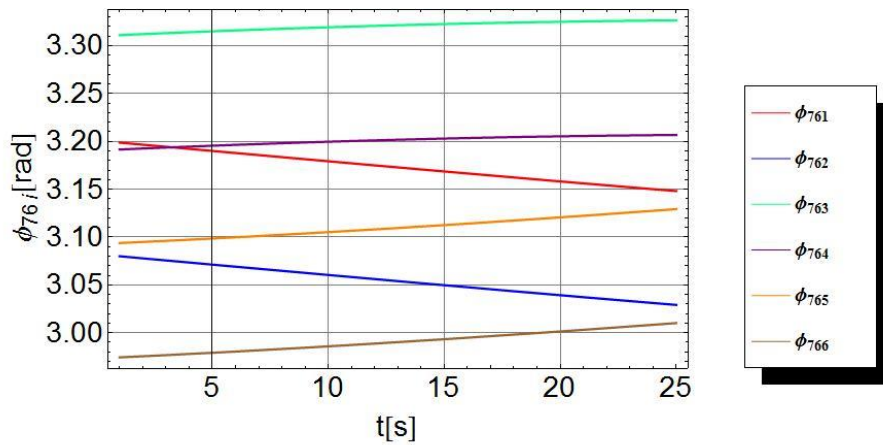

Fig. 4.3 Gráfica para ϕ_{76i}

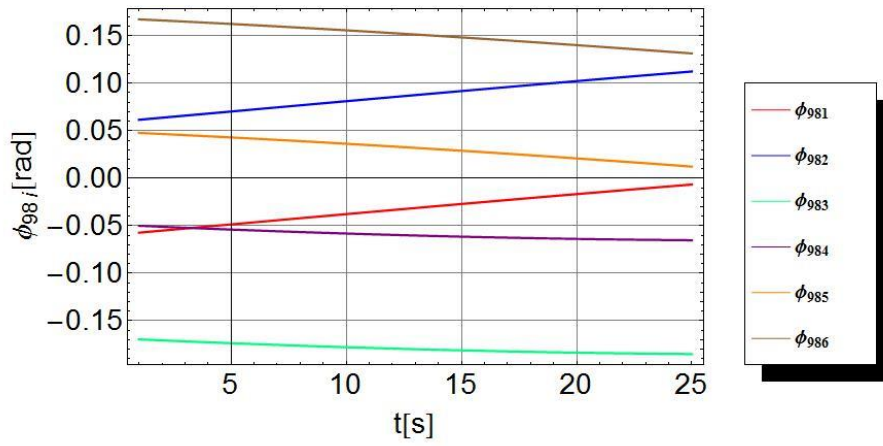

Fig. 4.4 Gráfica para ϕ_{98i}

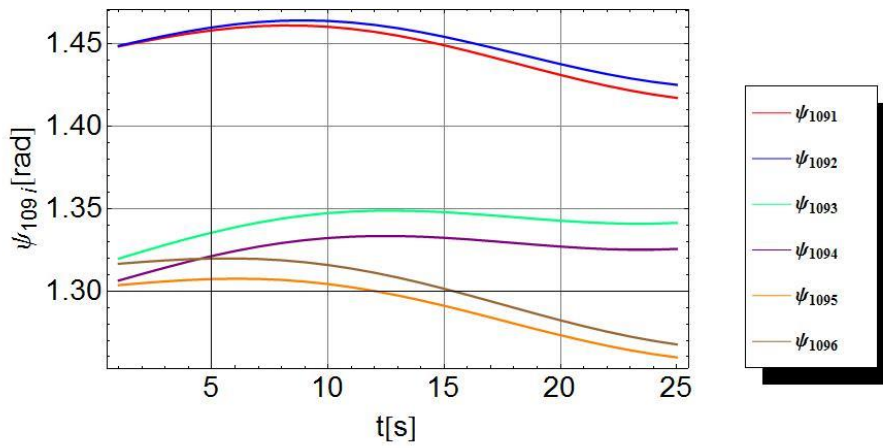

Fig. 4.5 Gráfica para ψ_{109i}

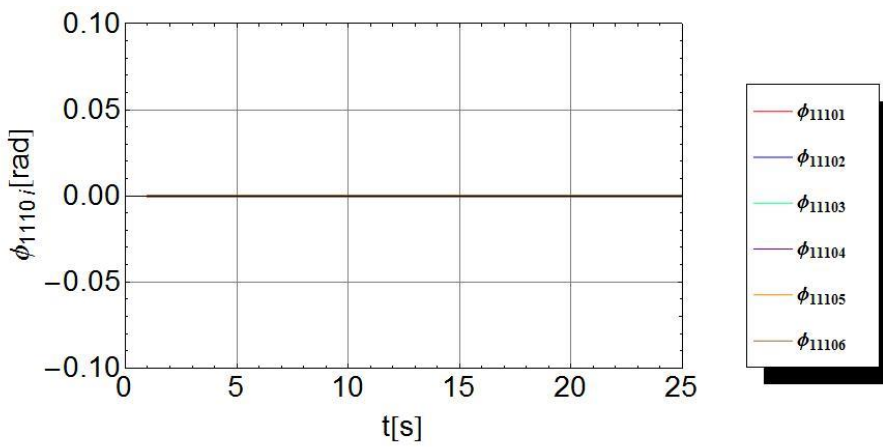

Fig. 4.6 Gráfica para ϕ_{1110i}

4.2 Gráficas de Velocidad

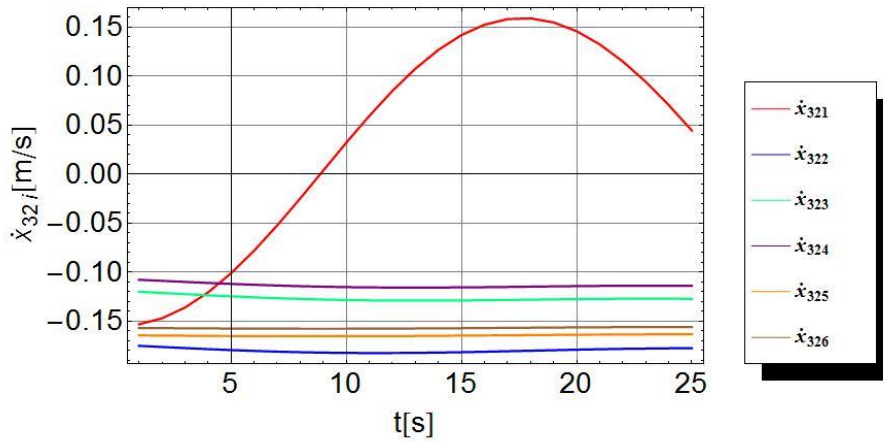

Fig. 4.7 Gráfica para \dot{x}_{32i}

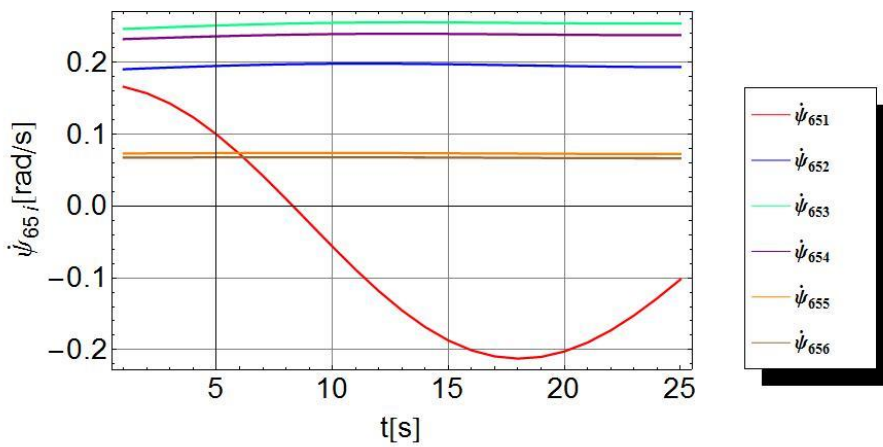

Fig. 4.8 Gráfica para $\dot{\psi}_{65i}$

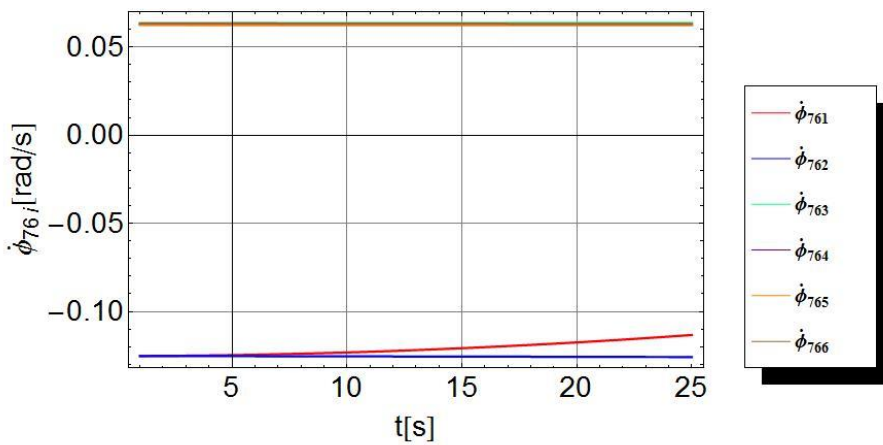

Fig. 4.9 Gráfica para $\dot{\phi}_{76i}$

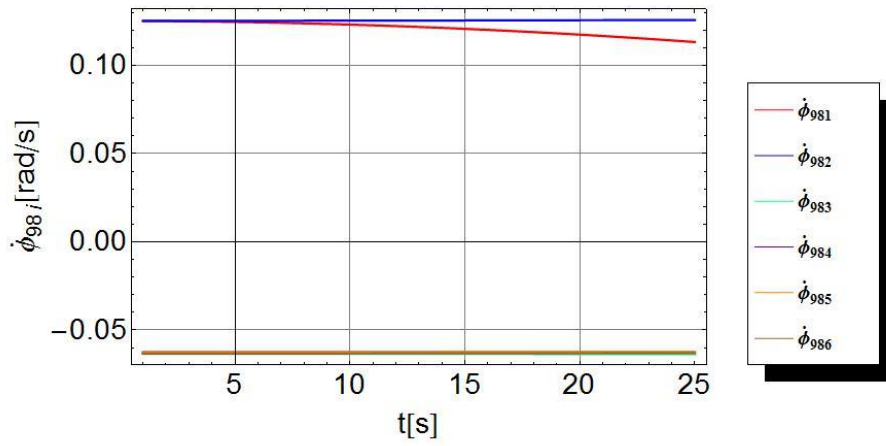

Fig. 4.10 Gráfica para $\dot{\phi}_{98i}$

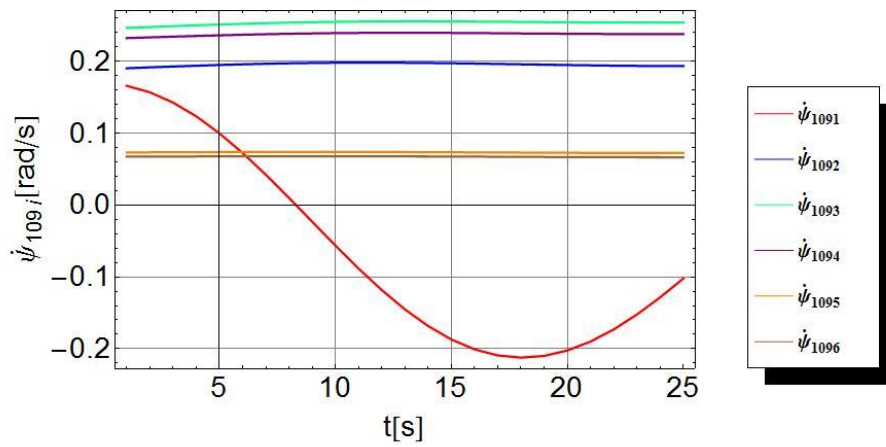

Fig. 4.11 Gráfica para $\dot{\psi}_{109i}$

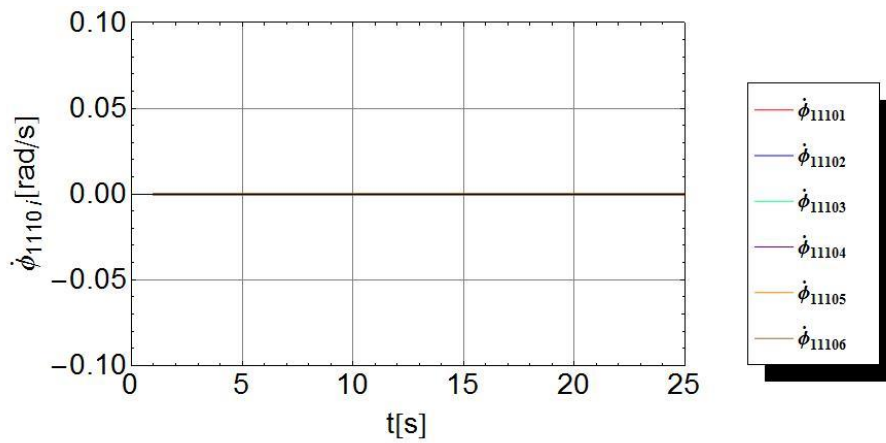

Fig. 4.12 Gráfica para $\dot{\phi}_{1110i}$

4.3 Gráficas de Aceleración

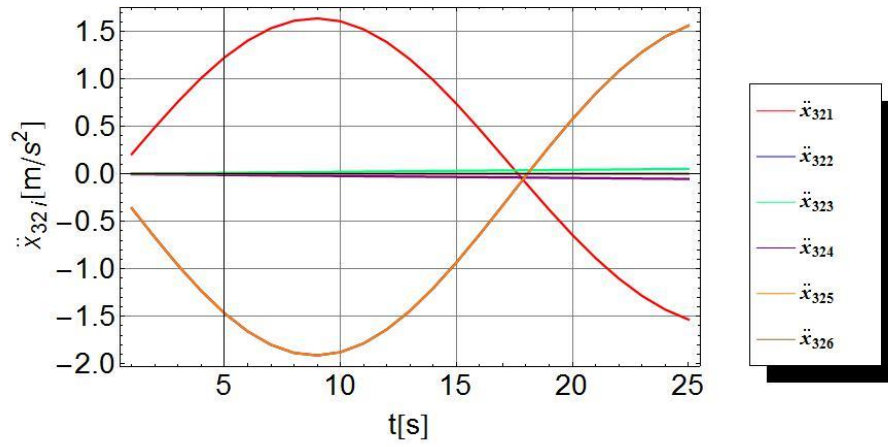

Fig. 4.13 Gráfica para \ddot{x}_{32i}

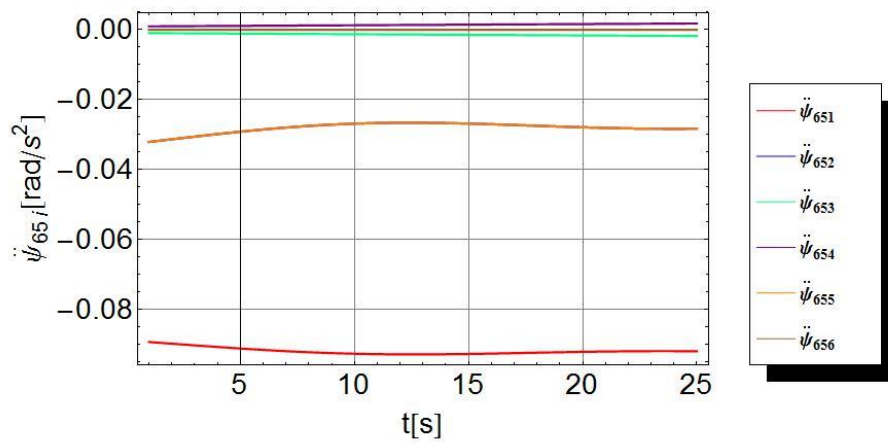

Fig. 4.14 Gráfica para $\ddot{\psi}_{65i}$

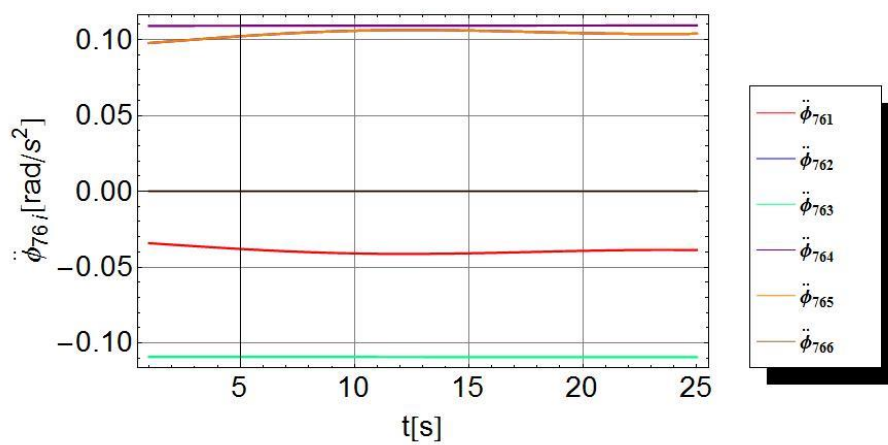

Fig. 4.15 Gráfica para $\ddot{\phi}_{76i}$

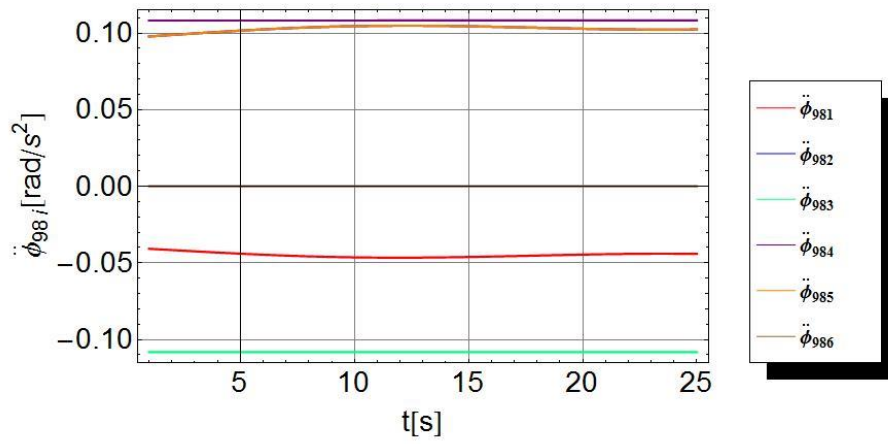

Fig. 4.16 Gráfica para $\ddot{\phi}_{98i}$

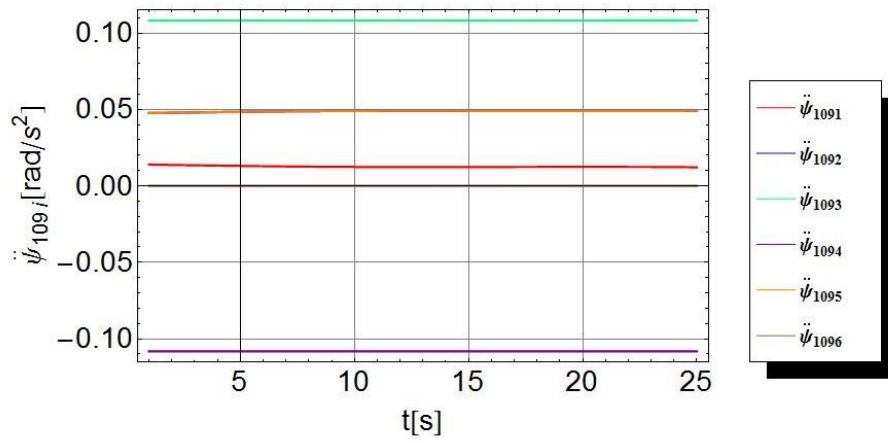

Fig. 4.17 Gráfica para $\ddot{\psi}_{109i}$

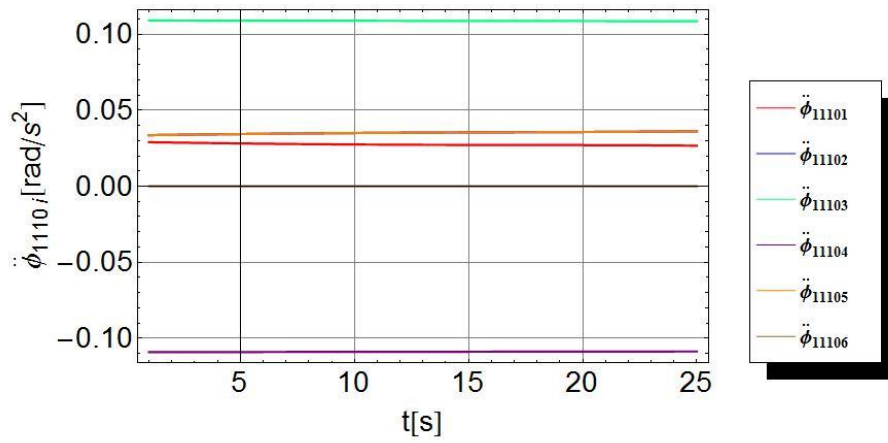

Fig. 4.18 Gráfica para $\ddot{\phi}_{1110i}$

4.4. Solución del método Euler-Lagrange

La solución del método de Euler-Lagrange, se obtuvo con ayuda del software Mathematica, y consistió en programar la ecuación 3.100 con cada uno de los términos que la componen. Los datos de masas, inercias y fuerzas externas son obtenidos a partir del CAD y del material que constituirá al sistema. En la figura 4.19 se muestra la gráfica de torques obtenida para el análisis dinámico, correspondiente a la trayectoria trazada en el apéndice A. Los parámetros de masa e inercia para cadena se muestran a continuación:

$$\begin{aligned}
 m_{1i} &= 1.760 \text{ Kg} \\
 m_{2i} &= 2.368 \text{ Kg} \\
 J_{G2i}^z &= \begin{bmatrix} 0.1011 & 0.0000 & 0.0000 \\ 0.0000 & 0.0005 & 0.0000 \\ 0.0000 & 0.0000 & 0.1011 \end{bmatrix} \text{ Kg} * m^2
 \end{aligned}
 \quad \text{Para } i = 1,2,3,4,5,6$$

Por otra parte, los datos de masa e inercia de la plataforma y la carga son:

$$\begin{aligned}
 m_p &= 35.035 \text{ Kg} & m_c &= 30 \text{ Kg} \\
 J_{G2}^z &= \begin{bmatrix} 0.8669 & 0.0000 & 0.0000 \\ 0.0000 & 1.7246 & 0.0000 \\ 0.0000 & 0.0000 & 0.8668 \end{bmatrix} \text{ Kg} * m^2 & J_{G2}^z &= \begin{bmatrix} 0.8669 & 0.0000 & 0.0000 \\ 0.0000 & 1.7246 & 0.0000 \\ 0.0000 & 0.0000 & 0.8668 \end{bmatrix} \text{ Kg} * m^2
 \end{aligned}$$

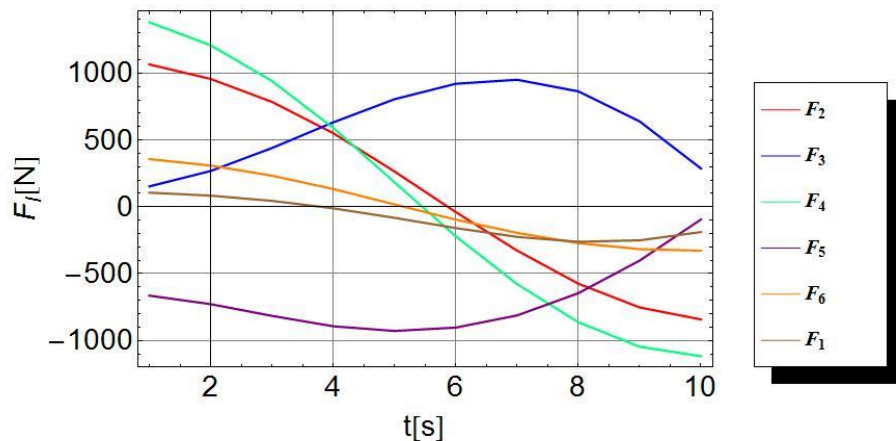

Fig. 4.19 Gráfica de fuerzas de los actuadores

A partir de los datos obtenidos de la posición x_{32i} y con la información de las fuerzas necesarias en los actuadores para mover una carga de 800 [N], fue posible obtener las curvas de trabajo y potencia necesarias para cumplir con la trayectoria descrita en el apéndice A.

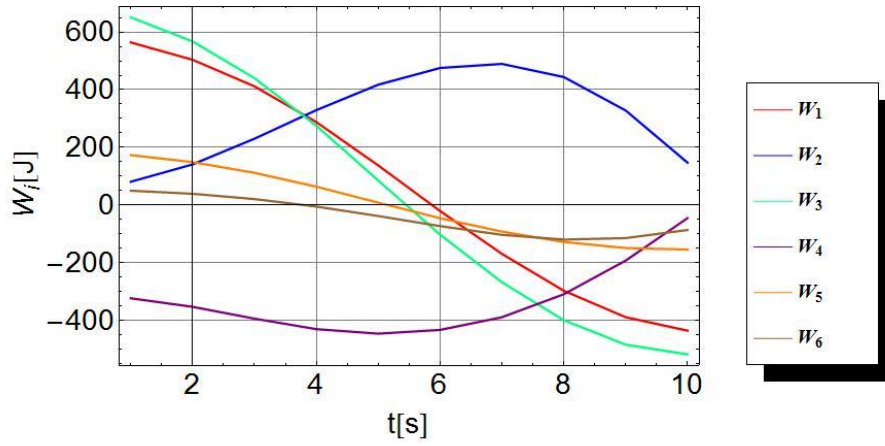

Fig. 4.20 Gráfica de trabajo mecánico efectuado por la fuerza F_i

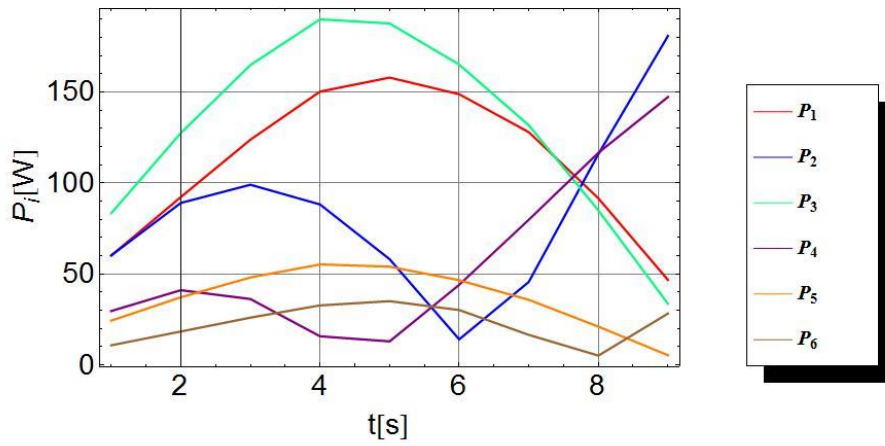

Fig. 4.21 Gráfica de potencia necesaria en los actuadores

Capítulo 5

Conclusiones

En el presente trabajo se realizó el estudio de la cinemática y dinámica de un robot paralelo de 6 grados de libertad utilizando el método de transformaciones homogéneas y el método de Euler-Lagrange, respectivamente. Ambos métodos permitieron la obtención de variables de gran interés para verificar que la estructura pueda cumplir con su principal propósito, sea en este caso, simular movimientos armónicos que representen en gran medida el comportamiento de los sismos comunes de la Ciudad de México.

El análisis a partir del método de transformaciones homogéneas permitió un desarrollo sencillo de la cinemática del robot, tomando en cuenta la geometría y los distintos tipos de juntas de la estructura. Una de las grandes ventajas de éste método es que, sin importar que tan complicada pueda ser la configuración de un robot, es posible aplicar una serie de transformaciones convenientemente definidas a través de la estructura del robot para representar la geometría y los movimientos posibles entre cada eslabón que lo conforman.

Utilizando las técnicas de la cinemática inversa, fue posible proponer una trayectoria y un conjunto de orientaciones basadas en el tipo de ondas provocadas por movimientos telúricos. Con esto, fue posible obtener el movimiento necesario de los actuadores lineales, así como las orientaciones de las juntas esféricas. En total, se lograron obtener seis variables por cadena cinemática (36 en total por todo el sistema).

Las simulaciones realizadas en el sistema para la trayectoria propuesta, nos permitieron demostrar que las velocidades y aceleraciones no generan picos considerables, y por ende, los actuadores no necesitan ejercer fuerzas excesivamente grandes para vencer y contrarrestar la inercia de los eslabones y la carga.

A partir del análisis por medio del método de Euler-Lagrange, se logró obtener el conjunto de fuerzas necesarias para mover una carga de 85 [Kg] (aprox. 830 [N]). Por otra parte, al conocer los desplazamientos lineales de los actuadores, fue posible calcular el trabajo y la potencia requerida por el sistema, siendo estas variables importantes en la etapa de selección de los actuadores más adecuados al sistema.

A diferencia de las mesas vibratorias, éste modelo permite contemplar todos los movimientos posibles en un espacio tridimensional, lo cual permite una representación más fiel a la realidad de los sismos ocurridos en cualquier parte del mundo.

Bibliografía

- [1] **Angeles, Jorge. 1997.** *Fundamentals of Robotic Mechanical Systems*. Montreal Quebec. Springer, 1997.
- [2] **Arai, T, et al. 1991.** Development of Parallel Link Manipulator for Underground Excavation Task. Proc. 1991 *International Symposium on Advanced Robot Technology*. 1991. pp. 541-548.
- [3] **Clavel, R. 1988.** A Fast Robot with Parallel Geometry. *Proc. 18th International Symposium on Industrial Robots*. 1988. pp. 91-100.
- [4] **Codourey, Alain. 1998.** *Dynamic Modelling of Parallel Robots for Computed-Torque Control Implementation*. Sagepublications, 1998, Vol. The International Journal of Robotics Research 1998; 17; 1325.
- [5] **Flores, Shair Mendoza. 2006.** *Análisis Cinemático y Dinámico de un Robot Delta de 3 Grados de Libertad*. México. D.F.: s.n., 2006.
- [6] **Giddings & Lewis. 1995.** *Gidding and Lewis Machine Tool*. Fond du Lac. 1995.
- [7] **Ahmadi, Mahdi, et al. 2008.** *Inverse Dynamics of Hexa Parallel Robot Using Lagrangian Dynamics Formulation*. Florida : IEEE, 2008, Vols. 12th International Conference on Intelligent Engineering Systems. February 25-29.
- [8] **McGill, David J. and King, Wilton. 1991.** *Mecánica para ingeniería y sus aplicaciones. Dinámica*. S.l. : Grupo Editorial Iberoamérica, 1991.
- [9] **Merlet, Jean Pierre. 2000.** *Parallel Robots. S.l. : Kluwer Academic Publishers, 2000.*
- [10] **Pierrot, F., Fournier, A. and Dauchez, P. 1991.** *Toward a Fully Parallel 6-DOF Robot for High-Speed Applications*. Proc. 1991 IEEE International Conference on Robotics and Automation. 1991. pp. 1288-1293.
- [11] **Reinholtz, C and Gahkale, D.** *Design an Analysis of Variable Geometry Truss Robot*. Proc. 9th Applied Mechanisms Conference. Oklahoma State University, Stillwater. OK : s.n.
- [12] **Spong, Mark W. and Vidyasagar, M. 1989.** *Robot Dynamics and Control*. S.l. : John Wiley & Sons, 1989. pp. 129-133.
- [13] **Stejskal, Vladimir and Valásek, Michael. 1996,** *Kinematics and Dynamics of Machinery*. s.l. : Marcel Dekker, Inc., 1996.
- [14] **Stewart, D. 1965.** *A platform with 6 degrees of freedom*. Proc. Institution of Mechanical Engineers. 1965. Vol. 180, pp. 371-386.

[15] **Tsai, Lun Wen.. 1999.** *"Robot Analysis" The mechanics of serial and parallel manipulators. s.l. : John Wiley & Sons, 1999.*

Apéndice A

Generación de Trayectoria

El movimiento de un cuerpo en el espacio tridimensional puede definirse a través de dos movimientos separados. En el primero de ellos, se puede establecer por medio de una trayectoria a través de un conjunto de rectas y /o curvas, la cual debe seguir algún punto del cuerpo de interés (por ejemplo, el centro de gravedad del órgano terminal). El segundo movimiento, se encarga de describir la orientación angular. Ambas ecuaciones deben cumplir con condiciones de posición, velocidad y aceleración lineal y angular, y se realizadas durante un tiempo definido. A continuación, se plantean las trayectorias propuestas para el centro de gravedad de la plataforma.

Trayectoria

La función aquí definida, representa una superposición de movimientos armónicos simples, acorde con el Teorema de Fourier. Dicha trayectoria se compone de las siguientes ecuaciones paramétricas en el espacio tridimensional.

$$f(t) = \begin{cases} x_p = R \cos(t) \\ y_p = R \sin(t) \\ z_p = A \sin(\omega t) \end{cases}$$

Donde:

R = radio de la circunferencia en el plano XY [m]

A = Amplitud del movimiento armónico simple [m]

ω = Frecuencia angular del movimiento armónico simple [rad/s]

Además, se define:

$$\omega = 2\pi f$$

Donde:

f = Frecuencia del movimiento armónico simple [Hz]

Para obtener las ecuaciones de velocidad y aceleración, bastó con derivar una y dos veces las ecuaciones paramétricas:

$$v(t) = \begin{cases} \dot{x}_p = -R \sin(t) \\ \dot{y}_p = R \cos(t) \\ \dot{z}_p = \omega A \cos(\omega t) \end{cases} \quad a(t) = \begin{cases} \ddot{x}_p = -R \sin(t) \\ \ddot{y}_p = -R \sin(t) \\ \ddot{z}_p = -\omega^2 A \sin(\omega t) \end{cases}$$

En la figura A.1 se muestra la trayectoria aquí descrita, para los siguientes parámetros:

$$\begin{aligned} R &= 0.1 \text{ [m]} \\ A &= 0.010 \text{ [m]} \\ f &= 10 \text{ [Hz]} \end{aligned}$$

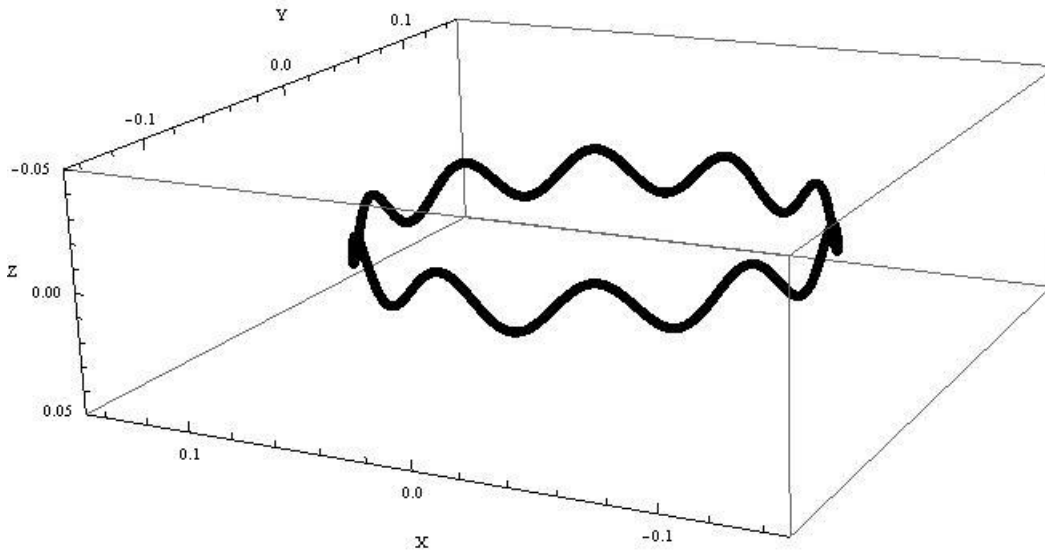

Fig. A.1 Trayectoria Propuesta

Orientación Angular

Para la orientación angular, también se definieron movimientos que representaran la superposición de ondas a través de los tres grados de libertad disponibles. Las ecuaciones se muestran a continuación:

$$\begin{aligned} \theta_p[t] &= A_1 \cos(f_1 t) \\ \psi_p[t] &= A_2 \cos(f_2 t) \\ \phi_p[t] &= A_3 \cos(f_3 t) \end{aligned}$$

Donde

A_i = Amplitud del movimiento armónico simple para la orientación i
 f_i = Frecuencia del movimiento armónico simple para la orientación i

Para obtener las ecuaciones de velocidad y aceleración, bastó con derivar una y dos veces las ecuaciones paramétricas, lo cual condujo a las siguientes ecuaciones:

$$\dot{\theta}_p[t] = -f_1 A_1 \sin(f_1 t)$$

$$\dot{\psi}_p[t] = -f_2 A_2 \sin(f_2 t)$$

$$\dot{\phi}_p[t] = -f_3 A_3 \sin(f_3 t)$$

$$\theta_p[t] = -f_1^2 A_1 \cos(f_1 t)$$

$$\psi_p[t] = -f_2^2 A_2 \cos(f_2 t)$$

$$\phi_p[t] = -f_3^2 A_3 \cos(f_3 t)$$

Apéndice B

Coefficientes de la ecuación 2.45

$$\begin{aligned}
V_{8i} &= -2c_{54i}Z_i + c_{54i}^2 + X_i^2 + Z_i^2 \\
V_{9i} &= c\gamma_{10i}(z_p - c_{54i}c\beta_{21i} + x_{32i}s\beta_{21i} + a_{1312i}s(\gamma_{1413i} - \phi_p)s\theta_p + a_{1312i}c(\gamma_{1413i} - \phi_p)c\theta_p s\psi_p) \\
V_{10i} &= s\gamma_{10i}(z_p - c_{54i}c\beta_{21i} + x_{32i}s\beta_{21i} + a_{1312i}s(\gamma_{1413i} - \phi_p)s\theta_p + a_{1312i}c(\gamma_{1413i} - \phi_p)c\theta_p s\psi_p) \\
V_{11i} &= x_{32i}c\beta_{21i} + c\gamma_{10i}(-x_p + a_{1312i}c(\gamma_{1413i} - \phi_p)c\psi_p) + c_{54i}s\beta_{21i} - s\gamma_{10i}(y_p + a_{1312i}s(\gamma_{1413i} \\
&\quad - \phi_p)c\theta_p - a_{1312i}c(\gamma_{1413i} - \phi_p)s\theta_p s\psi_p) \\
V_{12i} &= -0.5a_{1312i}(2a_{1312i}\cos^2(\theta_p)(c(\gamma_{1413i} - \phi_p)^2\sin^2(\psi_p) + s(\gamma_{1413i} - \phi_p)^2)s\beta_{21i}^2s\gamma_{10i} \\
&\quad + c\theta_p s\beta_{21i}(-a_{1312i}s(2(\gamma_{1413i} - \phi_p))c\gamma_{10i}c\psi_p s\beta_{21i} + 2s(\gamma_{1413i} - \phi_p)(-c_{54i} + x_p c\gamma_{10i}s\beta_{21i} \\
&\quad + y_p s\beta_{21i}s\gamma_{10i}) + 2c(\gamma_{1413i} - \phi_p)(x_{32i} + z_p s\beta_{21i})s\gamma_{10i}s\psi_p) + 2c\beta_{21i}(-s(\gamma_{1413i} - \phi_p)(x_{32i}c\theta_p \\
&\quad + c_{54i}s\gamma_{10i}s\theta_p) + c(\gamma_{1413i} - \phi_p)(-c_{54i}c\theta_p s\gamma_{10i} + x_{32i}s\theta_p)s\psi_p) \\
&\quad + s\theta_p(a_{1312i}c(\gamma_{1413i} - \phi_p)^2s(2\psi_p)c\gamma_{10i} + 2s\beta_{21i}(a_{1312i}c(\gamma_{1413i} - \phi_p)^2\sin^2(\psi_p)s\beta_{21i}s\gamma_{10i}s\theta_p \\
&\quad + s(\gamma_{1413i} - \phi_p)s\gamma_{10i}(x_{32i} + s\beta_{21i}(z_p + a_{1312i}s(\gamma_{1413i} - \phi_p)s\theta_p))) + c(\gamma_{1413i} - \phi_p)(c_{54i} \\
&\quad - s\beta_{21i}(x_p c\gamma_{10i} + y_p s\gamma_{10i}))s\psi_p) + c\beta_{21i}^2(c\gamma_{10i}(2x_p s(\gamma_{1413i} - \phi_p)c\theta_p - a_{1312i}s(2(\gamma_{1413i} \\
&\quad - \phi_p))c\theta_p c\psi_p - 2x_p c(\gamma_{1413i} - \phi_p)s\theta_p s\psi_p) + 2s\gamma_{10i}(a_{1312i}c(\gamma_{1413i} - \phi_p)^2\sin^2(\psi_p) + s(\gamma_{1413i} \\
&\quad - \phi_p)(a_{1312i}s(\gamma_{1413i} - \phi_p) + y_p c\theta_p + z_p s\theta_p) + c(\gamma_{1413i} - \phi_p)(z_p c\theta_p - y_p s\theta_p)s\psi_p))) \\
V_{13i} &= a_{1312i}c(\gamma_{1413i} - \phi_p)(c\psi_p(c\theta_p(c_{54i}s\beta_{21i} - y_p s\gamma_{10i}) - s\gamma_{10i}(a_{1312i}s(\gamma_{1413i} - \phi_p) + (z_p \\
&\quad + x_{32i}s\beta_{21i})s\theta_p) + c\beta_{21i}(x_{32i}c\theta_p + c_{54i}s\gamma_{10i}s\theta_p)) + c\gamma_{10i}(c\theta_p(a_{1312i}c(\gamma_{1413i} - \phi_p) - x_p c\psi_p) \\
&\quad + (z_p - c_{54i}c\beta_{21i} + x_{32i}s\beta_{21i} + a_{1312i}s(\gamma_{1413i} - \phi_p)s\theta_p)s\psi_p)) \\
V_{14i} &= -a_{1312i}(s\gamma_{1413i}(c\theta_p(z_p - c_{54i}c\beta_{21i} + x_{32i}s\beta_{21i})s\gamma_{10i} + (x_{32i}c\beta_{21i} + c_{54i}s\beta_{21i} - y_p s\gamma_{10i})s\theta_p)s\phi_p \\
&\quad + c\gamma_{1413i}(c\theta_p c\phi_p(z_p - c_{54i}c\beta_{21i} + x_{32i}s\beta_{21i})s\gamma_{10i} + c\phi_p(x_{32i}c\beta_{21i} - x_p c\gamma_{10i} + c_{54i}s\beta_{21i} \\
&\quad - y_p s\gamma_{10i})s\theta_p - c\gamma_{10i}c\psi_p(z_p - c_{54i}c\beta_{21i} + x_{32i}s\beta_{21i})s\phi_p) + (a_{1312i}s\gamma_{10i} + s(\gamma_{1413i} \\
&\quad - \phi_p)(-c\theta_p(x_{32i}c\beta_{21i} + c_{54i}s\beta_{21i} - y_p s\gamma_{10i}) + (z_p - c_{54i}c\beta_{21i} + x_{32i}s\beta_{21i})s\gamma_{10i}s\theta_p))s\psi_p \\
&\quad + c\gamma_{10i}(c\phi_p c\psi_p(z_p - c_{54i}c\beta_{21i} + x_{32i}s\beta_{21i})s\gamma_{1413i} + a_{1312i}c\psi_p s\theta_p - x_p s\gamma_{1413i}s\theta_p s\phi_p \\
&\quad + x_p s(\gamma_{1413i} - \phi_p)c\theta_p s\psi_p)) \\
V_{15i} &= c_{54i} - s\beta_{21i}(c\gamma_{10i}(x_p - a_{1312i}c(\gamma_{1413i} - \phi_p)c\psi_p) + (y_p + a_{1312i}s(\gamma_{1413i} - \phi_p)c\theta_p)s\gamma_{10i}) \\
&\quad - c\beta_{21i}(z_p + a_{1312i}s(\gamma_{1413i} - \phi_p)s\theta_p) + a_{1312i}c(\gamma_{1413i} - \phi_p)(-c\beta_{21i}c\theta_p + s\beta_{21i}s\gamma_{10i}s\theta_p)s\psi_p
\end{aligned}$$

Coefficientes de la ecuación 2.49

$$\begin{aligned}
V_{16i} &= Y_i^2 \cos^2(\psi_{65i}) + X_i^2 \\
V_{17i} &= c\psi_{65i}(c\beta_{21i}(-y_p + b_{43i}c\gamma_{10i} - a_{1312i}s(\gamma_{1413i} - \phi_p)c\theta_p + a_{1312i}c(\gamma_{1413i} - \phi_p)s\theta_p s\psi_p) \\
&\quad + s\gamma_{10i}(x_{32i} + s\beta_{21i}(z_p + a_{1312i}s(\gamma_{1413i} - \phi_p)s\theta_p + a_{1312i}c(\gamma_{1413i} - \phi_p)c\theta_p s\psi_p))) \\
V_{18i} &= -c\psi_{65i}(-c\beta_{21i}(x_p - a_{1312i}c(\gamma_{1413i} - \phi_p)c\psi_p + b_{43i}s\gamma_{10i}) + c\gamma_{10i}(x_{32i} + s\beta_{21i}(z_p \\
&\quad + a_{1312i}s(\gamma_{1413i} - \phi_p)s\theta_p + a_{1312i}c(\gamma_{1413i} - \phi_p)c\theta_p s\psi_p))) \\
V_{19i} &= c\psi_{65i}s\beta_{21i}(-b_{43i} + (-x_p + a_{1312i}c(\gamma_{1413i} - \phi_p)c\psi_p)s\gamma_{10i} + c\gamma_{10i}(y_p + a_{1312i}s(\gamma_{1413i} - \phi_p)c\theta_p \\
&\quad - a_{1312i}c(\gamma_{1413i} - \phi_p)s\theta_p s\psi_p))
\end{aligned}$$

$$\begin{aligned}
 V_{20i} &= 0.5a_{1312i}c\psi_{65i}(2a_{1312i}c(\gamma_{1413i} - \phi_p)^2 \sin^2(\psi_p)c\gamma_{10i}s\beta_{21i} \\
 &\quad + 2a_{1312i}\cos^2(\theta_p)s(\gamma_{1413i} - \phi_p)^2c\gamma_{10i}s\beta_{21i} + s\theta_p(a_{1312i}s(2(\gamma_{1413i} - \phi_p))c\beta_{21i}c\psi_p + 2s(\gamma_{1413i} \\
 &\quad - \phi_p)(-c\beta_{21i}(x_p + b_{43i}s\gamma_{10i}) + c\gamma_{10i}(x_{32i} + s\beta_{21i}(z_p + a_{1312i}s(\gamma_{1413i} - \phi_p)s\theta_p)))) + 2c(\gamma_{1413i} \\
 &\quad - \phi_p)s\beta_{21i}(b_{43i} - y_p c\gamma_{10i} + (x_p - a_{1312i}c(\gamma_{1413i} - \phi_p)c\psi_p)s\gamma_{10i})s\theta_p s\psi_p \\
 &\quad + c\theta_p(s\beta_{21i}(a_{1312i}s(2(\gamma_{1413i} - \phi_p))c\psi_p s\gamma_{10i} - 2s(\gamma_{1413i} - \phi_p)(b_{43i} - y_p c\gamma_{10i} + x_p s\gamma_{10i})) \\
 &\quad + 2c(\gamma_{1413i} - \phi_p)(c\gamma_{10i}(x_{32i} + z_p s\beta_{21i}) - c\beta_{21i}(x_p - a_{1312i}c(\gamma_{1413i} - \phi_p)c\psi_p \\
 &\quad + b_{43i}s\gamma_{10i}))s\psi_p)) \\
 V_{21i} &= a_{1312i}c(\gamma_{1413i} - \phi_p)c\psi_{65i}(c\gamma_{10i}c\psi_p(a_{1312i}s(\gamma_{1413i} - \phi_p)s\beta_{21i} + (x_{32i} + z_p s\beta_{21i})s\theta_p) \\
 &\quad + s\gamma_{10i}(x_{32i} + s\beta_{21i}(z_p + a_{1312i}s(\gamma_{1413i} - \phi_p)s\theta_p))s\psi_p + c\theta_p(s\beta_{21i}(a_{1312i}c(\gamma_{1413i} - \phi_p)s\gamma_{10i} \\
 &\quad - c\psi_p(b_{43i} - y_p c\gamma_{10i} + x_p s\gamma_{10i})) - a_{1312i}s(\gamma_{1413i} - \phi_p)c\beta_{21i}s\psi_p) + c\beta_{21i}((a_{1312i}c(\gamma_{1413i} - \phi_p) \\
 &\quad - c\psi_p(x_p + b_{43i}s\gamma_{10i}))s\theta_p + (-y_p + b_{43i}c\gamma_{10i})s\psi_p)) \\
 V_{22i} &= a_{1312i}c\psi_{65i}(-s(\gamma_{1413i} - \phi_p)c\psi_p(x_{32i} + z_p s\beta_{21i})s\gamma_{10i} + s\beta_{21i}(-a_{1312i}c\psi_p s\gamma_{10i} + c(\gamma_{1413i} \\
 &\quad - \phi_p)(b_{43i} + x_p s\gamma_{10i}))s\theta_p - s(\gamma_{1413i} - \phi_p)c\theta_p s\beta_{21i}(b_{43i} + x_p s\gamma_{10i})s\psi_p + c\gamma_{10i}(c(\gamma_{1413i} \\
 &\quad - \phi_p)(c\theta_p(x_{32i} + z_p s\beta_{21i}) - y_p s\beta_{21i}s\theta_p) + (a_{1312i}s\beta_{21i} + s(\gamma_{1413i} - \phi_p)(y_p c\theta_p s\beta_{21i} + (x_{32i} \\
 &\quad + z_p s\beta_{21i})s\theta_p))s\psi_p) + c\beta_{21i}(-c\theta_p(-a_{1312i}c\psi_p + c(\gamma_{1413i} - \phi_p)(x_p + b_{43i}s\gamma_{10i})) + s(\gamma_{1413i} \\
 &\quad - \phi_p)((y_p - b_{43i}c\gamma_{10i})c\psi_p - (x_p + b_{43i}s\gamma_{10i})s\theta_p s\psi_p)) \\
 V_{23i} &= c\psi_{65i}(-b_{43i} + (-x_p + a_{1312i}c(\gamma_{1413i} - \phi_p)c\psi_p)s\gamma_{10i} + c\gamma_{10i}(y_p + a_{1312i}s(\gamma_{1413i} - \phi_p)c\theta_p \\
 &\quad - a_{1312i}c(\gamma_{1413i} - \phi_p)s\theta_p s\psi_p)) \\
 V_{24i} &= s\psi_{65i}(-b_{43i} + (-x_p + a_{1312i}c(\gamma_{1413i} - \phi_p)c\psi_p)s\gamma_{10i} + c\gamma_{10i}(y_p + a_{1312i}s(\gamma_{1413i} - \phi_p)c\theta_p \\
 &\quad - a_{1312i}c(\gamma_{1413i} - \phi_p)s\theta_p s\psi_p))(-x_{32i} - s\beta_{21i}(z_p + a_{1312i}s(\gamma_{1413i} - \phi_p)s\theta_p + a_{1312i}c(\gamma_{1413i} \\
 &\quad - \phi_p)c\theta_p s\psi_p) + c\beta_{21i}(c\gamma_{10i}(x_p - a_{1312i}c(\gamma_{1413i} - \phi_p)c\psi_p) + s\gamma_{10i}(y_p + a_{1312i}s(\gamma_{1413i} \\
 &\quad - \phi_p)c\theta_p - a_{1312i}c(\gamma_{1413i} - \phi_p)s\theta_p s\psi_p))
 \end{aligned}$$

Coefficientes de la ecuación 2.53

$$\begin{aligned}
 V_{25i} &= a_{31i}^2 + a_{32i}^2 \\
 V_{26i} &= 0 \\
 V_{27i} &= 0 \\
 V_{28i} &= 0 \\
 V_{29i} &= 0.125(4c\psi_p(-s(2(\beta_{21i} + \psi_{65i}))c\gamma_{10i}c\theta_p + s(2\gamma_{10i})s(\beta_{21i} + \psi_{65i})^2 s\theta_p) + (6 - 2c(2\gamma_{10i}) \\
 &\quad + 2c(2(\beta_{21i} + \psi_{65i})) + c(2(\beta_{21i} - \gamma_{10i} + \psi_{65i})) + c(2(\beta_{21i} + \gamma_{10i} + \psi_{65i})))s\psi_p) \\
 V_{30i} &= -(s(\beta_{21i} + \psi_{65i})c\theta_p s\gamma_{10i} + c(\beta_{21i} + \psi_{65i})s\theta_p)(c(\beta_{21i} + \psi_{65i})c\theta_p c\psi_p + s(\beta_{21i} \\
 &\quad + \psi_{65i})(-c\psi_p s\gamma_{10i}s\theta_p + c\gamma_{10i}s\psi_p)) \\
 V_{31i} &= \frac{1}{64}(2c(2(\beta_{21i} - \gamma_{10i} + \psi_{65i})) + 2c(2(\beta_{21i} + \gamma_{10i} + \psi_{65i})) - 6c(2(\beta_{21i} - \theta_p + \psi_{65i})) + c(2(\beta_{21i} \\
 &\quad - \gamma_{10i} - \theta_p + \psi_{65i})) + c(2(\beta_{21i} + \gamma_{10i} - \theta_p + \psi_{65i})) - 6c(2(\beta_{21i} + \theta_p + \psi_{65i})) + c(2(\beta_{21i} \\
 &\quad - \gamma_{10i} + \theta_p + \psi_{65i})) + c(2(\beta_{21i} + \gamma_{10i} + \theta_p + \psi_{65i})) - 4c(2\theta_p)(1 + (1 + 3c(2(\beta_{21i} \\
 &\quad + \psi_{65i})))c(2\psi_p)) + 4c(2\gamma_{10i})(-1 - 2\cos^2(\psi_p)c(2\theta_p) + (3 + c(2\theta_p)c(2(\beta_{21i} + \psi_{65i})))c(2\psi_p)) \\
 &\quad + 4c(2(\beta_{21i} + \psi_{65i}))(1 - 6c(2\psi_p)c\gamma_{10i}^2) + 4s(2(\beta_{21i} + \psi_{65i}))(-2s(2\psi_p)c\gamma_{10i}c\theta_p \\
 &\quad + c(2\psi_p)s(2\theta_p)s\gamma_{10i})) - 4(-11 + c(2\psi_p) + s(2\beta_{21i} - \gamma_{10i} - 2\theta_p + 2\psi_{65i}) - s(2\beta_{21i} + \gamma_{10i} \\
 &\quad - 2\theta_p + 2\psi_{65i}) - s(2\beta_{21i} - \gamma_{10i} + 2(\theta_p + \psi_{65i})) + s(2\beta_{21i} + \gamma_{10i} + 2(\theta_p + \psi_{65i})) \\
 &\quad - 8s(2\gamma_{10i})s(\beta_{21i} + \psi_{65i})^2 s(2\psi_p)s\theta_p)) \\
 V_{32i} &= 0
 \end{aligned}$$

$$\begin{aligned}
 V_{33i} = & 0.015(2c(2(\beta_{21i} - \gamma_{10i} + \psi_{65i})) + 2c(2(\beta_{21i} + \gamma_{10i} + \psi_{65i})) - 6c(2(\beta_{21i} - \theta_p + \psi_{65i})) \\
 & + c(2(\beta_{21i} - \gamma_{10i} - \theta_p + \psi_{65i})) + c(2(\beta_{21i} + \gamma_{10i} - \theta_p + \psi_{65i})) - 6c(2(\beta_{21i} + \theta_p + \psi_{65i})) \\
 & + c(2(\beta_{21i} - \gamma_{10i} + \theta_p + \psi_{65i})) + c(2(\beta_{21i} + \gamma_{10i} + \theta_p + \psi_{65i})) - 4c(2\theta_p)(1 + (1 + 3c(2(\beta_{21i} \\
 & + \psi_{65i})))c(2\psi_p)) + 4c(2\gamma_{10i})(-1 - 2\cos^2(\psi_p)c(2\theta_p) + (3 + c(2\theta_p)c(2(\beta_{21i} + \psi_{65i})))c(2\psi_p)) \\
 & + 4(c(2(\beta_{21i} + \psi_{65i}))(1 - 6c(2\psi_p)c\gamma_{10i}^2) + 4s(2(\beta_{21i} + \psi_{65i}))(-2s(2\psi_p)c\gamma_{10i}c\theta_p \\
 & + c(2\psi_p)s(2\theta_p)s\gamma_{10i})) - 4(-11 + c(2\psi_p) + s(2\beta_{21i} - \gamma_{10i} - 2\theta_p + 2\psi_{65i}) - s(2\beta_{21i} + \gamma_{10i} \\
 & - 2\theta_p + 2\psi_{65i}) - s(2\beta_{21i} - \gamma_{10i} + 2(\theta_p + \psi_{65i})) + s(2\beta_{21i} + \gamma_{10i} + 2(\theta_p + \psi_{65i})) \\
 & - 8s(2\gamma_{10i})s(\beta_{21i} + \psi_{65i})^2s(2\psi_p)s\theta_p)) \\
 V_{34i} = & 0
 \end{aligned}$$

Coefficientes de la ecuación 2.57

$$\begin{aligned}
 V_{35i} &= \frac{\cos^2(\psi_{109i})\csc(\phi_{1110i})}{a_{33i}^2} \\
 V_{36i} &= 0 \\
 V_{37i} &= 0 \\
 V_{38i} &= 0 \\
 V_{39i} &= 0.125(c(\gamma_{1211i} + \gamma_{1413i} - \theta_p - \phi_p - \psi_p)s(2\gamma_{10i})s(\beta_{21i} + \psi_{65i})^2 + 2c(\gamma_{1211i} + \gamma_{1413i} - \phi_p)(3 \\
 & + c(2(\beta_{21i} + \psi_{65i})) - 2c(2\gamma_{10i})s(\beta_{21i} + \psi_{65i})^2)c\psi_p + s(2\gamma_{10i})s(\beta_{21i} + \psi_{65i})^2(4s(\gamma_{1211i} \\
 & + \gamma_{1413i} - \phi_p)c\theta_p - c(\gamma_{1211i} + \gamma_{1413i} - \theta_p - \phi_p)c\psi_p + (s(\gamma_{1211i} + \gamma_{1413i} - \theta_p - \phi_p) \\
 & - 2s(\gamma_{1211i} + \gamma_{1413i} + \theta_p - \phi_p))s\psi_p) + 4s(2(\beta_{21i} + \psi_{65i}))c\gamma_{10i}(s(\gamma_{1211i} + \gamma_{1413i} - \phi_p)s\theta_p \\
 & + c(\gamma_{1211i} + \gamma_{1413i} - \phi_p)c\theta_p s\psi_p)) \\
 V_{40i} &= -\cos^2(\theta_p)c(\beta_{21i} + \psi_{65i})^2s(\gamma_{1211i} + \gamma_{1413i} - \phi_p) - s(\gamma_{1211i} + \gamma_{1413i} - \phi_p)s(\beta_{21i} + \psi_{65i})^2c\gamma_{10i}^2 \\
 & - c(\gamma_{1211i} + \gamma_{1413i} - \phi_p)s(\beta_{21i} + \psi_{65i})^2c\gamma_{10i}c\theta_p c\psi_p s\gamma_{10i} - \sin^2(\theta_p)s(\gamma_{1211i} + \gamma_{1413i} \\
 & - \phi_p)s(\beta_{21i} + \psi_{65i})^2s\gamma_{10i}^2 - c(\gamma_{1211i} + \gamma_{1413i} - \phi_p)c(\beta_{21i} + \psi_{65i})s(\beta_{21i} + \psi_{65i})c\gamma_{10i}c\psi_p s\theta_p \\
 & + s(\gamma_{1211i} + \gamma_{1413i} - \phi_p)s(2(\beta_{21i} + \psi_{65i}))c\theta_p s\gamma_{10i} s\theta_p + c(\gamma_{1211i} + \gamma_{1413i} - \phi_p)(s(\beta_{21i} \\
 & + \psi_{65i})c\theta_p s\gamma_{10i} + c(\beta_{21i} + \psi_{65i})s\theta_p)(c(\beta_{21i} + \psi_{65i})c\theta_p - s(\beta_{21i} + \psi_{65i})s\gamma_{10i} s\theta_p)s\psi_p \\
 V_{41i} &= (c\phi_p(s(\beta_{21i} + \psi_{65i}))(-c(\gamma_{1211i} + \gamma_{1413i})c\gamma_{10i}c\psi_p + s(\gamma_{1211i} + \gamma_{1413i})c\theta_p s\gamma_{10i}) + c(\beta_{21i} \\
 & + \psi_{65i})s(\gamma_{1211i} + \gamma_{1413i})s\theta_p) - (s(\gamma_{1211i} + \gamma_{1413i})s(\beta_{21i} + \psi_{65i})c\gamma_{10i}c\psi_p + c(\gamma_{1211i} \\
 & + \gamma_{1413i})(s(\beta_{21i} + \psi_{65i})c\theta_p s\gamma_{10i} + c(\beta_{21i} + \psi_{65i})s\theta_p))s\phi_p + c(\gamma_{1211i} + \gamma_{1413i} - \phi_p)(c(\beta_{21i} \\
 & + \psi_{65i})c\theta_p - s(\beta_{21i} + \psi_{65i})s\gamma_{10i} s\theta_p)s\psi_p)(c(\beta_{21i} + \psi_{65i})c\theta_p c\psi_p + s(\beta_{21i} \\
 & + \psi_{65i})(-c\psi_p s\gamma_{10i} s\theta_p + c\gamma_{10i} s\psi_p)) \\
 V_{42i} &= 0 \\
 V_{43i} &= s(\gamma_{1211i} + \gamma_{1413i} - \phi_p)c\gamma_{10i}c\theta_p + c(\gamma_{1211i} + \gamma_{1413i} - \phi_p)(c\psi_p s\gamma_{10i} - c\gamma_{10i} s\theta_p s\psi_p) \\
 V_{44i} &= 0 \\
 V_{45i} &= -\cot(\phi_{1110i})(c(\gamma_{1211i} + \gamma_{1413i})(c(\beta_{21i} + \psi_{65i})c\phi_p s\theta_p + s(\beta_{21i} + \psi_{65i})(c\theta_p c\phi_p s\gamma_{10i} \\
 & - c\gamma_{10i}c\psi_p s\phi_p)) + s(\gamma_{1211i} + \gamma_{1413i})(c(\beta_{21i} + \psi_{65i})s\theta_p s\phi_p + s(\beta_{21i} + \psi_{65i})(c\gamma_{10i}c\phi_p c\psi_p \\
 & + c\theta_p s\gamma_{10i} s\phi_p)) + s(\gamma_{1211i} + \gamma_{1413i} - \phi_p)(-c(\beta_{21i} + \psi_{65i})c\theta_p + s(\beta_{21i} \\
 & + \psi_{65i})s\gamma_{10i} s\theta_p)s\psi_p)(c(\beta_{21i} + \psi_{65i})c\theta_p c\psi_p + s(\beta_{21i} + \psi_{65i})(-c\psi_p s\gamma_{10i} s\theta_p + c\gamma_{10i} s\psi_p))
 \end{aligned}$$

Coefficientes de la ecuación 2.61

$$\begin{aligned}
 V_{46i} &= \frac{\cos^2(\phi_{98i})}{(a_{11i}c\phi_{1110i} - a_{12i}s\phi_{1110i})^2} \\
 V_{47i} &= 0 \\
 V_{48i} &= 0 \\
 V_{49i} &= 0 \\
 V_{50i} &= 0.125c\psi_{109i}(8c\psi_p(c(\beta_{21i} + \psi_{65i})c\gamma_{10i}c\phi_{76i} - s\gamma_{10i}s\phi_{76i})(c\phi_{76i}(s(\beta_{21i} + \psi_{65i})c\theta_p + c(\beta_{21i} \\
 &\quad + \psi_{65i})s\gamma_{10i}s\theta_p) + c\gamma_{10i}s\theta_p s\phi_{76i}) + (5 + c(2\gamma_{10i})(1 - 3c(2\phi_{76i})) + c(2\phi_{76i}) + 4c(\beta_{21i} \\
 &\quad + \psi_{65i})s(2\gamma_{10i})s(2\phi_{76i}) - 4\cos^2(\phi_{76i})c(2(\beta_{21i} + \psi_{65i}))c\gamma_{10i}^2)s\psi_p) \\
 V_{51i} &= -c\psi_{109i}(s(\beta_{21i} + \psi_{65i})c\phi_{76i}s\theta_p - c\theta_p(c(\beta_{21i} + \psi_{65i})c\phi_{76i}s\gamma_{10i} \\
 &\quad + c\gamma_{10i}s\phi_{76i}))(s\phi_{76i}(c\gamma_{10i}c\psi_p s\theta_p + s\gamma_{10i}s\psi_p) + c\phi_{76i}(s(\beta_{21i} + \psi_{65i})c\theta_p c\psi_p + c(\beta_{21i} \\
 &\quad + \psi_{65i})(c\psi_p s\gamma_{10i}s\theta_p - c\gamma_{10i}s\psi_p))) \\
 V_{52i} &= 0.0625c\psi_{109i}((8 + 4\cos^2(\psi_p)c(2\theta_p) - c(2(\theta_p - \phi_{76i})) - c(2(\theta_p + \phi_{76i})) + c(2(\beta_{21i} - \phi_{76i} \\
 &\quad + \psi_{65i})) + c(2(\beta_{21i} + \phi_{76i} + \psi_{65i})) + c(2(\beta_{21i} + \psi_{65i}))(2 + 4\cos^2(\phi_{76i})c(2\psi_p)) - 2c(2\phi_{76i})(2 \\
 &\quad + (-2 + c(2\theta_p))c(2\psi_p)))c\gamma_{10i}^2 + c\gamma_{10i}(-8\cos^2(\psi_p)s(2\theta_p)s(2\phi_{76i})s(\beta_{21i} + \psi_{65i}) \\
 &\quad + 8\cos^2(\phi_{76i})s(2(\beta_{21i} + \psi_{65i}))s(2\psi_p)c\theta_p) + 2(\cos^2(\theta_p)\cos^2(\phi_{76i})(-(-4 + 2c(2\gamma_{10i}) \\
 &\quad + c(2(\beta_{21i} - \gamma_{10i} + \psi_{65i})) + c(2(\beta_{21i} + \gamma_{10i} + \psi_{65i})))s(\gamma_{1211i} + \gamma_{1413i}))^2 \\
 &\quad - 4c(2\psi_p)s(\beta_{21i} + \psi_{65i})^2) - 4s(2\phi_{76i})s(\beta_{21i} + \psi_{65i})s(2\psi_p)c\theta_p s\gamma_{10i} \\
 &\quad - c(\gamma_{1211i} + \gamma_{1413i})^2(-8\cos^2(\psi_p)\sin^2(\phi_{76i})s\gamma_{10i}^2 + \cos^2(\phi_{76i})(\cos^2(\theta_p)(-4 + 2c(2\gamma_{10i}) \\
 &\quad + c(2(\beta_{21i} - \gamma_{10i} + \psi_{65i})) + c(2(\beta_{21i} + \gamma_{10i} + \psi_{65i})))) - 8\sin^2(\theta_p)s(\beta_{21i} + \psi_{65i})^2 \\
 &\quad + 4\cos^2(\psi_p)s(2\theta_p)s(2(\beta_{21i} + \psi_{65i}))s\gamma_{10i})) \\
 &\quad + 4(2\cos^2(\phi_p)s(\gamma_{1211i} + \gamma_{1413i}))^2(\cos^2(\phi_{76i})\sin^2(\theta_p)s(\beta_{21i} + \psi_{65i})^2 + \cos^2(\psi_p)\sin^2(\phi_{76i})s\gamma_{10i}^2) \\
 &\quad + s(\gamma_{1211i} + \gamma_{1413i})^2(2\cos^2(\phi_{76i})\sin^2(\theta_p)\sin^2(\phi_p)s(\beta_{21i} + \psi_{65i})^2 \\
 &\quad + \cos^2(\psi_p)s\gamma_{10i}(-\cos^2(\phi_{76i})s(2\theta_p)s(2(\beta_{21i} + \psi_{65i})) + 2\sin^2(\phi_{76i})\sin^2(\phi_p)s\gamma_{10i})) \\
 &\quad - \sin^2(\phi_{76i})s(2\gamma_{10i})s(2\psi_p)s\theta_p + c(\beta_{21i} + \psi_{65i})s(2\phi_{76i})(-\cos^2(\psi_p)\sin^2(\theta_p)s(2\gamma_{10i}) \\
 &\quad + \sin^2(\psi_p)s(2\gamma_{10i}) + c(2\gamma_{10i})s(2\psi_p)s\theta_p) + \cos^2(\phi_{76i})c(\beta_{21i} + \psi_{65i})^2 s\theta_p(s(2\gamma_{10i})s(2\psi_p) \\
 &\quad + 2\sin^2(\psi_p)s\gamma_{10i}^2 s\theta_p)))) \\
 V_{53i} &= 0 \\
 V_{54i} &= c\phi_{76i}c\psi_{109i}(-c\psi_p(s(\beta_{21i} + \psi_{65i})c\theta_p + c(\beta_{21i} + \psi_{65i})s\gamma_{10i}s\theta_p)s\phi_{76i} + c\phi_{76i}s\gamma_{10i}s\psi_p \\
 &\quad + c\gamma_{10i}(c\phi_{76i}c\psi_p s\theta_p + c(\beta_{21i} + \psi_{65i})s\phi_{76i}s\psi_p)) \\
 V_{55i} &= -c\psi_{109i}(c(\beta_{21i} + \psi_{65i})c\theta_p c\psi_p + s(\beta_{21i} + \psi_{65i})(-c\psi_p s\gamma_{10i}s\theta_p + c\gamma_{10i}s\psi_p)) \\
 V_{56i} &= -c\psi_{109i}((c(\beta_{21i} + \psi_{65i})s(\gamma_{1211i} + \gamma_{1413i} - \phi_p)c\theta_p c\phi_{76i}s\gamma_{10i} - s(\gamma_{1211i} + \gamma_{1413i})s(\beta_{21i} \\
 &\quad + \psi_{65i})c\phi_{76i}c\phi_p s\theta_p + s(\gamma_{1211i} + \gamma_{1413i})c\psi_p s\gamma_{10i}s\phi_{76i}s\phi_p + c(\gamma_{1211i} + \gamma_{1413i})(c\phi_p c\psi_p s\gamma_{10i}s\phi_{76i} \\
 &\quad + s(\beta_{21i} + \psi_{65i})c\phi_{76i}s\theta_p s\phi_p) - c(\gamma_{1211i} + \gamma_{1413i} - \phi_p)c\phi_{76i}(s(\beta_{21i} + \psi_{65i})c\theta_p + c(\beta_{21i} \\
 &\quad + \psi_{65i})s\gamma_{10i}s\theta_p)s\psi_p - c\gamma_{10i}(-s(\gamma_{1211i} + \gamma_{1413i} - \phi_p)c\theta_p s\phi_{76i} + c(\gamma_{1211i} + \gamma_{1413i} - \phi_p)(c(\beta_{21i} \\
 &\quad + \psi_{65i})c\phi_{76i}c\psi_p + s\theta_p s\phi_{76i}s\psi_p)))^2 \\
 &\quad + (s(\gamma_{1211i} + \gamma_{1413i})(c\phi_p c\psi_p(c(\beta_{21i} + \psi_{65i})c\gamma_{10i}c\phi_{76i} - s\gamma_{10i}s\phi_{76i}) + s(\beta_{21i} \\
 &\quad + \psi_{65i})c\phi_{76i}(-s\theta_p s\phi_p + c\theta_p c\phi_p s\psi_p) + (c(\beta_{21i} + \psi_{65i})c\phi_{76i}s\gamma_{10i} + c\gamma_{10i}s\phi_{76i})(c\theta_p s\phi_p \\
 &\quad + c\phi_p s\theta_p s\psi_p)) + c(\gamma_{1211i} + \gamma_{1413i})(c\psi_p(-c(\beta_{21i} + \psi_{65i})c\gamma_{10i}c\phi_{76i} + s\gamma_{10i}s\phi_{76i})s\phi_p - s(\beta_{21i} \\
 &\quad + \psi_{65i})c\phi_{76i}(c\phi_p s\theta_p + c\theta_p s\phi_p s\psi_p) + (c(\beta_{21i} + \psi_{65i})c\phi_{76i}s\gamma_{10i} + c\gamma_{10i}s\phi_{76i})(c\theta_p c\phi_p \\
 &\quad - s\theta_p s\phi_p s\psi_p)))^2)
 \end{aligned}$$

$$\begin{aligned}
 V_{57i} = & s\psi_{109i}(c(2\phi_{1110i})(-c(\beta_{21i} + \psi_{65i})s(\gamma_{1211i} + \gamma_{1413i} - \phi_p)c\theta_p c\phi_{76i}s\gamma_{10i} + s(\gamma_{1211i} + \gamma_{1413i})s(\beta_{21i} \\
 & + \psi_{65i})c\phi_{76i}c\phi_p s\theta_p - s(\gamma_{1211i} + \gamma_{1413i})c\psi_p s\gamma_{10i}s\phi_{76i}s\phi_p - c(\gamma_{1211i} + \gamma_{1413i})(c\phi_p c\psi_p s\gamma_{10i}s\phi_{76i} \\
 & + s(\beta_{21i} + \psi_{65i})c\phi_{76i}s\theta_p s\phi_p) + c(\gamma_{1211i} + \gamma_{1413i} - \phi_p)c\phi_{76i}(s(\beta_{21i} + \psi_{65i})c\theta_p + c(\beta_{21i} \\
 & + \psi_{65i})s\gamma_{10i}s\theta_p)s\psi_p + c\gamma_{10i}(-s(\gamma_{1211i} + \gamma_{1413i} - \phi_p)c\theta_p s\phi_{76i} + c(\gamma_{1211i} + \gamma_{1413i} - \phi_p)(c(\beta_{21i} \\
 & + \psi_{65i})c\phi_{76i}c\psi_p + s\theta_p s\phi_{76i}s\psi_p)))(s(\gamma_{1211i} + \gamma_{1413i})(c\phi_p c\psi_p(c(\beta_{21i} + \psi_{65i})c\gamma_{10i}c\phi_{76i} \\
 & - s\gamma_{10i}s\phi_{76i}) + s(\beta_{21i} + \psi_{65i})c\phi_{76i}(-s\theta_p s\phi_p + c\theta_p c\phi_p s\psi_p) + (c(\beta_{21i} + \psi_{65i})c\phi_{76i}s\gamma_{10i} \\
 & + c\gamma_{10i}s\phi_{76i})(c\theta_p s\phi_p + c\phi_p s\theta_p s\psi_p)) + c(\gamma_{1211i} + \gamma_{1413i})(c\psi_p(-c(\beta_{21i} + \psi_{65i})c\gamma_{10i}c\phi_{76i} \\
 & + s\gamma_{10i}s\phi_{76i})s\phi_p - s(\beta_{21i} + \psi_{65i})c\phi_{76i}(c\phi_p s\theta_p + c\theta_p s\phi_p s\psi_p) + (c(\beta_{21i} + \psi_{65i})c\phi_{76i}s\gamma_{10i} \\
 & + c\gamma_{10i}s\phi_{76i})(c\theta_p c\phi_p - s\theta_p s\phi_p s\psi_p))) \\
 & + c\phi_{1110i}s\phi_{1110i}((c(\beta_{21i} + \psi_{65i})s(\gamma_{1211i} + \gamma_{1413i} - \phi_p)c\theta_p c\phi_{76i}s\gamma_{10i} - s(\gamma_{1211i} + \gamma_{1413i})s(\beta_{21i} \\
 & + \psi_{65i})c\phi_{76i}c\phi_p s\theta_p + s(\gamma_{1211i} + \gamma_{1413i})c\psi_p s\gamma_{10i}s\phi_{76i}s\phi_p + c(\gamma_{1211i} + \gamma_{1413i})(c\phi_p c\psi_p s\gamma_{10i}s\phi_{76i} \\
 & + s(\beta_{21i} + \psi_{65i})c\phi_{76i}s\theta_p s\phi_p) - c(\gamma_{1211i} + \gamma_{1413i} - \phi_p)c\phi_{76i}(s(\beta_{21i} + \psi_{65i})c\theta_p + c(\beta_{21i} \\
 & + \psi_{65i})s\gamma_{10i}s\theta_p)s\psi_p - c\gamma_{10i}(-s(\gamma_{1211i} + \gamma_{1413i} - \phi_p)c\theta_p s\phi_{76i} + c(\gamma_{1211i} + \gamma_{1413i} - \phi_p)(c(\beta_{21i} \\
 & + \psi_{65i})c\phi_{76i}c\psi_p + s\theta_p s\phi_{76i}s\psi_p)))^2 \\
 & - (s(\gamma_{1211i} + \gamma_{1413i})(c\phi_p c\psi_p(c(\beta_{21i} + \psi_{65i})c\gamma_{10i}c\phi_{76i} - s\gamma_{10i}s\phi_{76i}) + s(\beta_{21i} \\
 & + \psi_{65i})c\phi_{76i}(-s\theta_p s\phi_p + c\theta_p c\phi_p s\psi_p) + (c(\beta_{21i} + \psi_{65i})c\phi_{76i}s\gamma_{10i} + c\gamma_{10i}s\phi_{76i})(c\theta_p s\phi_p \\
 & + c\phi_p s\theta_p s\psi_p)) + c(\gamma_{1211i} + \gamma_{1413i})(c\psi_p(-c(\beta_{21i} + \psi_{65i})c\gamma_{10i}c\phi_{76i} + s\gamma_{10i}s\phi_{76i})s\phi_p - s(\beta_{21i} \\
 & + \psi_{65i})c\phi_{76i}(c\phi_p s\theta_p + c\theta_p s\phi_p s\psi_p) + (c(\beta_{21i} + \psi_{65i})c\phi_{76i}s\gamma_{10i} + c\gamma_{10i}s\phi_{76i})(c\theta_p c\phi_p \\
 & - s\theta_p s\phi_p s\psi_p)))^2))
 \end{aligned}$$

Apéndice C

Coefficientes de la ecuación X.XX

$$\begin{aligned}
V_{58i} &= -2c_{54i}Z_i + c_{54i}^2 + X_i^2 + Z_i^2 \\
G_{1i} &= 2(-x_p + x_{32i}c\beta_{21i}c\gamma_{10i} + a_{1312i}c(\gamma_{1413i} - \phi_p)c\psi_p + c_{54i}c\gamma_{10i}s\beta_{21i} - b_{43i}s\gamma_{10i}) \\
G_{2i} &= 2(-y_p + b_{43i}c\gamma_{10i} - a_{1312i}s(\gamma_{1413i} - \phi_p)c\theta_p + x_{32i}c\beta_{21i}s\gamma_{10i} + c_{54i}s\beta_{21i}s\gamma_{10i} + a_{1312i}c(\gamma_{1413i} \\
&\quad - \phi_p)s\theta_p s\psi_p) \\
G_{3i} &= 2(z_p - c_{54i}c\beta_{21i} + x_{32i}s\beta_{21i} + a_{1312i}s(\gamma_{1413i} - \phi_p)s\theta_p + a_{1312i}c(\gamma_{1413i} - \phi_p)c\theta_p s\psi_p) \\
G_{4i} &= -2a_{1312i}s(\gamma_{1413i} - \phi_p)(c\theta_p(z_p - c_{54i}c\beta_{21i} + x_{32i}s\beta_{21i}) + (-y_p + b_{43i}c\gamma_{10i} + x_{32i}c\beta_{21i}s\gamma_{10i} \\
&\quad + c_{54i}s\beta_{21i}s\gamma_{10i})s\theta_p) + 2a_{1312i}c(\gamma_{1413i} - \phi_p)(c\theta_p(y_p - b_{43i}c\gamma_{10i} - (x_{32i}c\beta_{21i} + c_{54i}s\beta_{21i})s\gamma_{10i}) \\
&\quad + (z_p - c_{54i}c\beta_{21i} + x_{32i}s\beta_{21i})s\theta_p)s\psi_p \\
G_{5i} &= 2a_{1312i}c(\gamma_{1413i} - \phi_p)(c\theta_p c\psi_p(z_p - c_{54i}c\beta_{21i} + x_{32i}s\beta_{21i}) + c\psi_p(-y_p + b_{43i}c\gamma_{10i} + x_{32i}c\beta_{21i}s\gamma_{10i} \\
&\quad + c_{54i}s\beta_{21i}s\gamma_{10i})s\theta_p + (x_p - c\gamma_{10i}(x_{32i}c\beta_{21i} + c_{54i}s\beta_{21i}) + b_{43i}s\gamma_{10i})s\psi_p) \\
G_{6i} &= 2a_{1312i}(c\phi_p c\psi_p(x_p - c\gamma_{10i}(x_{32i}c\beta_{21i} + c_{54i}s\beta_{21i}) + b_{43i}s\gamma_{10i})s\gamma_{1413i} + s\gamma_{1413i}(c\theta_p(y_p - b_{43i}c\gamma_{10i} \\
&\quad - (x_{32i}c\beta_{21i} + c_{54i}s\beta_{21i})s\gamma_{10i}) + (z_p - c_{54i}c\beta_{21i} + x_{32i}s\beta_{21i})s\theta_p)s\phi_p + c\gamma_{1413i}(c\theta_p c\phi_p(y_p \\
&\quad - b_{43i}c\gamma_{10i} - (x_{32i}c\beta_{21i} + c_{54i}s\beta_{21i})s\gamma_{10i}) + c\phi_p(z_p - c_{54i}c\beta_{21i} + x_{32i}s\beta_{21i})s\theta_p + c\psi_p(-x_p \\
&\quad + x_{32i}c\beta_{21i}c\gamma_{10i} + c_{54i}c\gamma_{10i}s\beta_{21i} - b_{43i}s\gamma_{10i})s\phi_p) - s(\gamma_{1413i} - \phi_p)(c\theta_p(z_p - c_{54i}c\beta_{21i} \\
&\quad + x_{32i}s\beta_{21i}) + (-y_p + b_{43i}c\gamma_{10i} + x_{32i}c\beta_{21i}s\gamma_{10i} + c_{54i}s\beta_{21i}s\gamma_{10i})s\theta_p)s\psi_p) \\
G_{7i} &= -2(\dot{x}_{32i}(B_{1i} + A_{1i}\dot{x}_{32i} + 2A_{1i}x_{32i}) + \dot{x}_p^2 + \dot{y}_p^2 + \dot{z}_p^2 - a_{1312i}(c\gamma_{1413i}(s\phi_p(2\dot{\phi}_p c\psi_p(-\dot{x}_p \\
&\quad + \dot{\psi}_p(-y_p + b_{43i}c\gamma_{10i} + x_{32i}c\beta_{21i}s\gamma_{10i} + c_{54i}s\beta_{21i}s\gamma_{10i})s\theta_p) + 2\dot{\phi}_p\dot{\psi}_p(x_p \\
&\quad - c\gamma_{10i}(x_{32i}c\beta_{21i} + c_{54i}s\beta_{21i}) + b_{43i}s\gamma_{10i})s\psi_p + s\theta_p(-2\dot{y}_p\dot{\theta}_p - 2\dot{\phi}_p(\dot{y}_p + \dot{\theta}_p z_p \\
&\quad - c_{54i}\dot{\theta}_p c\beta_{21i} + \dot{\theta}_p x_{32i}s\beta_{21i})s\psi_p - z_p(\dot{\theta}_p^2 + \dot{\phi}_p^2) + (c_{54i}c\beta_{21i} - x_{32i}s\beta_{21i})(\dot{\theta}_p^2 + \dot{\phi}_p^2))) \\
&\quad + c\theta_p(s\phi_p(2\dot{z}_p\dot{\theta}_p + 2\dot{\phi}_p(\dot{\psi}_p c\psi_p(z_p - c_{54i}c\beta_{21i} + x_{32i}s\beta_{21i}) + (\dot{z}_p - \dot{\theta}_p y_p)s\psi_p) - y_p(\dot{\theta}_p^2 \\
&\quad + \dot{\phi}_p^2) + b_{43i}c\gamma_{10i}(2\dot{\theta}_p\dot{\phi}_p s\psi_p + \dot{\theta}_p^2 + \dot{\phi}_p^2) + (x_{32i}c\beta_{21i} + c_{54i}s\beta_{21i})s\gamma_{10i}(2\dot{\theta}_p\dot{\phi}_p s\psi_p + \dot{\theta}_p^2 \\
&\quad + \dot{\phi}_p^2)) + c\phi_p(2\dot{\phi}_p(\dot{y}_p + \dot{\theta}_p z_p) - 2\dot{z}_p\dot{\psi}_p c\psi_p - 2\dot{\theta}_p(-\dot{\phi}_p x_{32i}s\beta_{21i} + c\beta_{21i}(c_{54i}\dot{\phi}_p \\
&\quad + \dot{\psi}_p x_{32i}c\psi_p s\gamma_{10i}) + \dot{\psi}_p c\psi_p(-y_p + b_{43i}c\gamma_{10i} + c_{54i}s\beta_{21i}s\gamma_{10i})) + s\psi_p(2\dot{y}_p\dot{\theta}_p \\
&\quad + z_p(\dot{\theta}_p^2 + \dot{\phi}_p^2 + \dot{\psi}_p^2) - (c_{54i}c\beta_{21i} - x_{32i}s\beta_{21i})(\dot{\theta}_p^2 + \dot{\phi}_p^2 + \dot{\psi}_p^2))) + c\phi_p(-2\dot{x}_p\dot{\psi}_p s\psi_p \\
&\quad + c\psi_p(2\dot{\psi}_p(\dot{y}_p + \dot{\theta}_p z_p - c_{54i}\dot{\theta}_p c\beta_{21i} + \dot{\theta}_p x_{32i}s\beta_{21i})s\theta_p - (x_p - c\gamma_{10i}(x_{32i}c\beta_{21i} \\
&\quad + c_{54i}s\beta_{21i}) + b_{43i}s\gamma_{10i})(\dot{\phi}_p^2 + \dot{\psi}_p^2)) + s\theta_p(2\dot{\phi}_p(\dot{z}_p - \dot{\theta}_p y_p + \dot{\theta}_p b_{43i}c\gamma_{10i} + \dot{\theta}_p(x_{32i}c\beta_{21i} \\
&\quad + c_{54i}s\beta_{21i})s\gamma_{10i}) + s\psi_p(2\dot{z}_p\dot{\theta}_p - y_p(\dot{\theta}_p^2 + \dot{\phi}_p^2 + \dot{\psi}_p^2) + (b_{43i}c\gamma_{10i} + x_{32i}c\beta_{21i}s\gamma_{10i} \\
&\quad + c_{54i}s\beta_{21i}s\gamma_{10i})(\dot{\theta}_p^2 + \dot{\phi}_p^2 + \dot{\psi}_p^2)))) + s\gamma_{1413i}(c\phi_p(2\dot{\phi}_p c\psi_p(\dot{x}_p + \dot{\psi}_p(y_p - b_{43i}c\gamma_{10i} \\
&\quad - (x_{32i}c\beta_{21i} + c_{54i}s\beta_{21i})s\gamma_{10i})s\theta_p) - 2\dot{\phi}_p\dot{\psi}_p(x_p - c\gamma_{10i}(x_{32i}c\beta_{21i} + c_{54i}s\beta_{21i}) \\
&\quad + b_{43i}s\gamma_{10i})s\psi_p + s\theta_p(2\dot{y}_p\dot{\theta}_p + 2\dot{\phi}_p(\dot{y}_p + \dot{\theta}_p z_p - c_{54i}\dot{\theta}_p c\beta_{21i} + \dot{\theta}_p x_{32i}s\beta_{21i})s\psi_p \\
&\quad + z_p(\dot{\theta}_p^2 + \dot{\phi}_p^2) - (c_{54i}c\beta_{21i} - x_{32i}s\beta_{21i})(\dot{\theta}_p^2 + \dot{\phi}_p^2))) - c\theta_p(c\phi_p(2\dot{z}_p\dot{\theta}_p + 2\dot{\phi}_p(\dot{\psi}_p c\psi_p(z_p \\
&\quad - c_{54i}c\beta_{21i} + x_{32i}s\beta_{21i}) + (\dot{z}_p - \dot{\theta}_p y_p)s\psi_p) - y_p(\dot{\theta}_p^2 + \dot{\phi}_p^2) + b_{43i}c\gamma_{10i}(2\dot{\theta}_p\dot{\phi}_p s\psi_p + \dot{\theta}_p^2 \\
&\quad + \dot{\phi}_p^2) + (x_{32i}c\beta_{21i} + c_{54i}s\beta_{21i})s\gamma_{10i}(2\dot{\theta}_p\dot{\phi}_p s\psi_p + \dot{\theta}_p^2 + \dot{\phi}_p^2)) + s\phi_p(-2\dot{\phi}_p(\dot{y}_p + \dot{\theta}_p z_p) \\
&\quad + 2\dot{z}_p\dot{\psi}_p c\psi_p + 2\dot{\theta}_p(-\dot{\phi}_p x_{32i}s\beta_{21i} + c\beta_{21i}(c_{54i}\dot{\phi}_p + \dot{\psi}_p x_{32i}c\psi_p s\gamma_{10i}) + \dot{\psi}_p c\psi_p(-y_p \\
&\quad + b_{43i}c\gamma_{10i} + c_{54i}s\beta_{21i}s\gamma_{10i})) - s\psi_p(2\dot{y}_p\dot{\theta}_p + z_p(\dot{\theta}_p^2 + \dot{\phi}_p^2 + \dot{\psi}_p^2) - (c_{54i}c\beta_{21i} \\
&\quad - x_{32i}s\beta_{21i})(\dot{\theta}_p^2 + \dot{\phi}_p^2 + \dot{\psi}_p^2))) + s\phi_p(-2\dot{x}_p\dot{\psi}_p s\psi_p + c\psi_p(2\dot{\psi}_p(\dot{y}_p + \dot{\theta}_p z_p - c_{54i}\dot{\theta}_p c\beta_{21i}
\end{aligned}$$

$$\begin{aligned}
 & + \dot{\theta}_p x_{32i} s\beta_{21i}) s\theta_p - (x_p - c\gamma_{10i}(x_{32i} c\beta_{21i} + c_{54i} s\beta_{21i}) + b_{43i} s\gamma_{10i})(\dot{\phi}_p^2 + \dot{\psi}_p^2)) \\
 & + s\theta_p(2\dot{\phi}_p(\dot{z}_p - \dot{\theta}_p y_p + \dot{\theta}_p b_{43i} c\gamma_{10i} + \dot{\theta}_p(x_{32i} c\beta_{21i} + c_{54i} s\beta_{21i}) s\gamma_{10i}) + s\psi_p(2\dot{z}_p \dot{\theta}_p \\
 & - y_p(\dot{\theta}_p^2 + \dot{\phi}_p^2 + \dot{\psi}_p^2)) + (b_{43i} c\gamma_{10i} + x_{32i} c\beta_{21i} s\gamma_{10i} + c_{54i} s\beta_{21i} s\gamma_{10i})(\dot{\theta}_p^2 + \dot{\phi}_p^2 \\
 & + \dot{\psi}_p^2))))))
 \end{aligned}$$

Coefficientes de la ecuación X.XX

$$\begin{aligned}
 V_{59i} &= -\frac{\cos^2(\psi_{65i})}{X^3} \\
 G_{8i} &= \frac{X_i(s\gamma_{10i} V_{58i} X_i + (G_i - c\beta_{21i} c\gamma_{10i} V_{58i})(c_{54i} - Z_i))}{V_{58i}} \\
 G_{9i} &= -\frac{X_i(c\gamma_{10i} V_{58i} X_i - (G_{2i} - c\beta_{21i} s\gamma_{10i} V_{58i})(c_{54i} - Z_i))}{V_{58i}} \\
 G_{10i} &= \frac{(G_{3i} + s\beta_{21i} V_{58i}) X_i (c_{54i} - Z_i)}{V_{58i}} \\
 G_{11i} &= \frac{1}{V_{58i}} X_i (a_{1312i} V_{58i} (c(\gamma_{1413i} - \phi_p) s\psi_p (c\gamma_{10i} c\theta_p X_i + (c\beta_{21i} c\theta_p s\gamma_{10i} - s\beta_{21i} s\theta_p)(c_{54i} - Z_i)) \\
 & + s(\gamma_{1413i} - \phi_p)(c\gamma_{10i} s\theta_p X_i + (c\theta_p s\beta_{21i} + c\beta_{21i} s\gamma_{10i} s\theta_p)(c_{54i} - Z_i))) + G_{4i}(c_{54i} - Z_i)) G_{12i} \\
 &= \frac{1}{V_{58i}} X_i ((c_{54i} - Z_i) G_{5i} + a_{1312i} c(\gamma_{1413i} - \phi_p)(c\psi_p (X_i c\gamma_{10i} s\theta_p + (c_{54i} - Z_i)(c\theta_p s\beta_{21i} \\
 & + c\beta_{21i} s\gamma_{10i} s\theta_p)) + ((-c_{54i} + Z_i) c\beta_{21i} c\gamma_{10i} + X_i s\gamma_{10i}) s\psi_p) V_{58i}) \\
 G_{12i} &= \frac{1}{V_{58i}} X_i (G_{5i}(c_{54i} - Z_i) + a_{1312i} c(\gamma_{1413i} - \phi_p) V_{58i} (c\psi_p (c\gamma_{10i} s\theta_p X_i + (c\theta_p s\beta_{21i} \\
 & + c\beta_{21i} s\gamma_{10i} s\theta_p)(c_{54i} - Z_i)) + s\psi_p (s\gamma_{10i} X_i + c\beta_{21i} c\gamma_{10i} (-c_{54i} + Z_i)))) \\
 G_{13i} &= \frac{1}{V_{58i}} X_i (a_{1312i} V_{58i} (-s(\gamma_{1413i} - \phi_p) c\psi_p s\gamma_{10i} X_i + c\gamma_{10i} (c(\gamma_{1413i} - \phi_p) c\theta_p X_i + s(\gamma_{1413i} \\
 & - \phi_p)(s\theta_p s\psi_p X_i + c\beta_{21i} c\psi_p (c_{54i} - Z_i))) + s\beta_{21i} (-c(\gamma_{1413i} - \phi_p) s\theta_p + s(\gamma_{1413i} \\
 & - \phi_p) c\theta_p s\psi_p)(c_{54i} - Z_i) + c\beta_{21i} s\gamma_{10i} (c(\gamma_{1413i} - \phi_p) c\theta_p + s(\gamma_{1413i} - \phi_p) s\theta_p s\psi_p)(c_{54i} - Z_i)) \\
 & + G_{6i}(c_{54i} - Z_i)) \\
 G_{14i} &= \frac{1}{V_{58i}} (c_{54i} X_i G_{7i} + 2X_i Z_i V_{58i} X_i + 2c_{54i} V_{58i} X_i^2 - 2V_{58i} Z_i X_i^2 + a_{1312i} c\gamma_{10i} V_{58i} X_i^2 (c\theta_p (2\dot{\theta}_p \dot{\psi}_p c(\gamma_{1413i} \\
 & - \phi_p) c\psi_p + s(\gamma_{1413i} - \phi_p)(2\dot{\theta}_p \dot{\phi}_p s\psi_p + \dot{\theta}_p^2 + \dot{\phi}_p^2)) + s\theta_p (2\dot{\phi}_p \dot{\psi}_p s(\gamma_{1413i} - \phi_p) c\psi_p - c(\gamma_{1413i} \\
 & - \phi_p)(2\dot{\theta}_p \dot{\phi}_p + s\psi_p(\dot{\theta}_p^2 + \dot{\phi}_p^2 + \dot{\psi}_p^2)))) - a_{1312i} c\beta_{21i} V_{58i} X_i (c_{54i} - Z_i)(c\gamma_{10i} (2\dot{\phi}_p \dot{\psi}_p s(\gamma_{1413i} \\
 & - \phi_p) s\psi_p + c(\gamma_{1413i} - \phi_p) c\psi_p (\dot{\phi}_p^2 + \dot{\psi}_p^2)) + s\gamma_{10i} (c\theta_p (-2\dot{\theta}_p \dot{\psi}_p c(\gamma_{1413i} - \phi_p) c\psi_p - s(\gamma_{1413i} \\
 & - \phi_p)(2\dot{\theta}_p \dot{\phi}_p s\psi_p + \dot{\theta}_p^2 + \dot{\phi}_p^2)) + s\theta_p (-2\dot{\phi}_p \dot{\psi}_p s(\gamma_{1413i} - \phi_p) c\psi_p + c(\gamma_{1413i} - \phi_p)(2\dot{\theta}_p \dot{\phi}_p \\
 & + s\psi_p(\dot{\theta}_p^2 + \dot{\phi}_p^2 + \dot{\psi}_p^2)))) + 2X_i Z_i (\dot{x}_{32i} (B_{1i} + A_{1i} \dot{x}_{32i} + 2A_{1i} x_{32i}) + \dot{x}_p^2 + \dot{y}_p^2 + \dot{z}_p^2 \\
 & - a_{1312i} (c\gamma_{1413i} (s\phi_p (2\dot{\phi}_p c\psi_p (-\dot{x}_p + \psi_p (-y_p + b_{43i} c\gamma_{10i} + x_{32i} c\beta_{21i} s\gamma_{10i} + c_{54i} s\beta_{21i} s\gamma_{10i}) s\theta_p) \\
 & + 2\dot{\phi}_p \dot{\psi}_p (x_p - c\gamma_{10i} (x_{32i} c\beta_{21i} + c_{54i} s\beta_{21i}) + b_{43i} s\gamma_{10i}) s\psi_p + s\theta_p (-2\dot{y}_p \dot{\theta}_p - 2\dot{\phi}_p (\dot{y}_p + \dot{\theta}_p z_p \\
 & - c_{54i} \dot{\theta}_p c\beta_{21i} + \dot{\theta}_p x_{32i} s\beta_{21i}) s\psi_p - z_p (\dot{\theta}_p^2 + \dot{\phi}_p^2) + (c_{54i} c\beta_{21i} - x_{32i} s\beta_{21i})(\dot{\theta}_p^2 + \dot{\phi}_p^2))) \\
 & + c\theta_p (s\phi_p (2\dot{z}_p \dot{\theta}_p + 2\dot{\phi}_p (\dot{\psi}_p c\psi_p (z_p - c_{54i} c\beta_{21i} + x_{32i} s\beta_{21i}) + (z_p - \dot{\theta}_p y_p) s\psi_p) - y_p (\dot{\theta}_p^2 + \dot{\phi}_p^2) \\
 & + b_{43i} c\gamma_{10i} (2\dot{\theta}_p \dot{\phi}_p s\psi_p + \dot{\theta}_p^2 + \dot{\phi}_p^2) + (x_{32i} c\beta_{21i} + c_{54i} s\beta_{21i}) s\gamma_{10i} (2\dot{\theta}_p \dot{\phi}_p s\psi_p + \dot{\theta}_p^2 + \dot{\phi}_p^2)) \\
 & + c\dot{\phi}_p (2\dot{\phi}_p (\dot{y}_p + \dot{\theta}_p z_p) - 2\dot{z}_p \dot{\psi}_p c\psi_p - 2\dot{\theta}_p (-\dot{\phi}_p x_{32i} s\beta_{21i} + c\beta_{21i} (c_{54i} \dot{\phi}_p + \dot{\psi}_p x_{32i} c\psi_p s\gamma_{10i}) \\
 & + \dot{\psi}_p c\psi_p (-y_p + b_{43i} c\gamma_{10i} + c_{54i} s\beta_{21i} s\gamma_{10i})) + s\psi_p (2\dot{y}_p \dot{\theta}_p + z_p (\dot{\theta}_p^2 + \dot{\phi}_p^2 + \dot{\psi}_p^2) - (c_{54i} c\beta_{21i} \\
 & - x_{32i} s\beta_{21i})(\dot{\theta}_p^2 + \dot{\phi}_p^2 + \dot{\psi}_p^2))) + c\dot{\phi}_p (-2\dot{x}_p \dot{\psi}_p s\psi_p + c\psi_p (2\dot{\psi}_p (\dot{y}_p + \dot{\theta}_p z_p - c_{54i} \dot{\theta}_p c\beta_{21i} \\
 & + \dot{\theta}_p x_{32i} s\beta_{21i}) s\theta_p - (x_p - c\gamma_{10i} (x_{32i} c\beta_{21i} + c_{54i} s\beta_{21i}) + b_{43i} s\gamma_{10i})(\dot{\phi}_p^2 + \dot{\psi}_p^2)) + s\theta_p (2\dot{\phi}_p (\dot{z}_p
 \end{aligned}$$

$$\begin{aligned}
 & -\theta_p y_p + \theta_p b_{43i} c\gamma_{10i} + \theta_p (x_{32i} c\beta_{21i} + c_{54i} s\beta_{21i}) s\gamma_{10i} + s\psi_p (2\dot{z}_p \theta_p - y_p (\theta_p^2 + \phi_p^2 + \psi_p^2)) \\
 & + (b_{43i} c\gamma_{10i} + x_{32i} c\beta_{21i} s\gamma_{10i} + c_{54i} s\beta_{21i} s\gamma_{10i}) (\theta_p^2 + \phi_p^2 + \psi_p^2) + s\gamma_{1413i} (c\phi_p (2\dot{\phi}_p c\psi_p (\dot{x}_p \\
 & - 2\dot{\phi}_p \psi_p (x_p - c\gamma_{10i} (x_{32i} c\beta_{21i} + c_{54i} s\beta_{21i}) + b_{43i} s\gamma_{10i}) s\psi_p + s\theta_p (2\dot{y}_p \theta_p + 2\dot{\phi}_p (\dot{y}_p + \theta_p z_p \\
 & - c_{54i} \dot{\theta}_p c\beta_{21i} + \dot{\theta}_p x_{32i} s\beta_{21i}) s\psi_p + z_p (\theta_p^2 + \phi_p^2) - (c_{54i} c\beta_{21i} - x_{32i} s\beta_{21i}) (\theta_p^2 + \phi_p^2))) \\
 & - c\theta_p (c\phi_p (2\dot{z}_p \theta_p + 2\dot{\phi}_p (\psi_p c\psi_p (z_p - c_{54i} c\beta_{21i} + x_{32i} s\beta_{21i}) + (z_p - \theta_p y_p) s\psi_p) - y_p (\theta_p^2 + \phi_p^2) \\
 & + b_{43i} c\gamma_{10i} (2\theta_p \dot{\phi}_p s\psi_p + \theta_p^2 + \phi_p^2) + (x_{32i} c\beta_{21i} + c_{54i} s\beta_{21i}) s\gamma_{10i} (2\theta_p \dot{\phi}_p s\psi_p + \theta_p^2 + \phi_p^2)) \\
 & + s\phi_p (-2\dot{\phi}_p (\dot{y}_p + \theta_p z_p) + 2\dot{z}_p \psi_p c\psi_p + 2\theta_p (-\dot{\phi}_p x_{32i} s\beta_{21i} + c\beta_{21i} (c_{54i} \dot{\phi}_p + \dot{\psi}_p x_{32i} c\psi_p s\gamma_{10i}) \\
 & + \dot{\psi}_p c\psi_p (-y_p + b_{43i} c\gamma_{10i} + c_{54i} s\beta_{21i} s\gamma_{10i})) - s\psi_p (2\dot{y}_p \theta_p + z_p (\theta_p^2 + \phi_p^2 + \psi_p^2) - (c_{54i} c\beta_{21i} \\
 & - x_{32i} s\beta_{21i}) (\theta_p^2 + \phi_p^2 + \psi_p^2))) + s\phi_p (-2\dot{x}_p \dot{\psi}_p s\psi_p + c\psi_p (2\dot{\psi}_p (\dot{y}_p + \theta_p z_p - c_{54i} \dot{\theta}_p c\beta_{21i} \\
 & + \dot{\theta}_p x_{32i} s\beta_{21i}) s\theta_p - (x_p - c\gamma_{10i} (x_{32i} c\beta_{21i} + c_{54i} s\beta_{21i}) + b_{43i} s\gamma_{10i}) (\phi_p^2 + \psi_p^2)) + s\theta_p (2\dot{\phi}_p (\dot{z}_p \\
 & - \theta_p y_p + \theta_p b_{43i} c\gamma_{10i} + \theta_p (x_{32i} c\beta_{21i} + c_{54i} s\beta_{21i}) s\gamma_{10i}) + s\psi_p (2\dot{z}_p \theta_p - y_p (\theta_p^2 + \phi_p^2 + \psi_p^2) \\
 & + (b_{43i} c\gamma_{10i} + x_{32i} c\beta_{21i} s\gamma_{10i} + c_{54i} s\beta_{21i} s\gamma_{10i}) (\theta_p^2 + \phi_p^2 + \psi_p^2)))) + V_{58i} X_i (a_{1312i} (s(\gamma_{1413i} \\
 & - \phi_p) (2\dot{\phi}_p \dot{\psi}_p s\gamma_{10i} s\psi_p X_i - s\beta_{21i} s\theta_p (c_{54i} - Z_i) (2\theta_p \dot{\phi}_p s\psi_p + \theta_p^2 + \phi_p^2)) + c(\gamma_{1413i} \\
 & - \phi_p) c\psi_p (2\theta_p \dot{\psi}_p s\beta_{21i} s\theta_p (-c_{54i} + Z_i) + s\gamma_{10i} X_i (\phi_p^2 + \psi_p^2))) + a_{1312i} c\theta_p s\beta_{21i} (c_{54i} \\
 & - Z_i) (2\dot{\phi}_p \dot{\psi}_p s(\gamma_{1413i} - \phi_p) c\psi_p - c(\gamma_{1413i} - \phi_p) (2\theta_p \dot{\phi}_p + s\psi_p (\theta_p^2 + \phi_p^2 + \psi_p^2))) \\
 & + 2\sec^2(\psi_{65i}) X_i^2 \psi_{65i}^2 \tan(\psi_{65i}))
 \end{aligned}$$

Coefficientes de la ecuación X.XX

$$\begin{aligned}
 V_{60i} &= -\frac{\cos^2(\phi_{76i})}{X_i^3} \\
 G_{15i} &= -\frac{X_i (Y_i G_{8i} s\psi_{65i} V_{58i} X_i + c\psi_{65i} V_{59i} (-Y_i G_{1i} + Y_i c\beta_{21i} c\gamma_{10i} V_{58i} + s\gamma_{10i} V_{58i} X_i))}{V_{58i} V_{59i}} \\
 G_{16i} &= X_i \left(-\frac{Y_i G_{9i} s\psi_{65i} X_i}{V_{59i}} + c\psi_{65i} (-Y_i c\beta_{21i} s\gamma_{10i} + \frac{Y_i G_{2i}}{V_{58i}} + c\gamma_{10i} X_i) \right) \\
 G_{17i} &= Y_i X_i (c\psi_{65i} (s\beta_{21i} + \frac{G_{3i}}{V_{58i}}) - \frac{G_{10i} s\psi_{65i} X_i}{V_{59i}}) \\
 G_{18i} &= \frac{1}{V_{58i} V_{59i}} X_i (-Y_i G_{11i} s\psi_{65i} V_{58i} X_i + c\psi_{65i} V_{59i} (Y_i G_{4i} + a_{1312i} V_{58i} (-c(\gamma_{1413i} \\
 & - \phi_p) s\psi_p (-Y_i c\beta_{21i} c\theta_p s\gamma_{10i} + Y_i s\beta_{21i} s\theta_p + c\gamma_{10i} c\theta_p X_i) + s(\gamma_{1413i} - \phi_p) (Y_i c\theta_p s\beta_{21i} \\
 & + s\theta_p (Y_i c\beta_{21i} s\gamma_{10i} - c\gamma_{10i} X_i)))) \\
 G_{19i} &= \frac{1}{V_{58i} V_{59i}} X_i (-Y_i G_{12i} s\psi_{65i} V_{58i} X_i + c\psi_{65i} V_{59i} (Y_i G_{5i} + a_{1312i} c(\gamma_{1413i} - \phi_p) V_{58i} (Y_i c\theta_p c\psi_p s\beta_{21i} \\
 & + c\psi_p s\theta_p (Y_i c\beta_{21i} s\gamma_{10i} - c\gamma_{10i} X_i) - s\psi_p (Y_i c\beta_{21i} c\gamma_{10i} + s\gamma_{10i} X_i)))) \\
 G_{20i} &= \frac{1}{V_{58i} V_{59i}} X_i (-Y_i G_{13i} s\psi_{65i} V_{58i} X_i + c\psi_{65i} V_{59i} (Y_i G_{6i} + a_{1312i} V_{58i} (Y_i s(\gamma_{1413i} - \phi_p) c\beta_{21i} c\gamma_{10i} c\psi_p \\
 & + Y_i c(\gamma_{1413i} - \phi_p) c\beta_{21i} c\theta_p s\gamma_{10i} - Y_i c(\gamma_{1413i} - \phi_p) s\beta_{21i} s\theta_p - c(\gamma_{1413i} - \phi_p) c\gamma_{10i} c\theta_p X_i + s(\gamma_{1413i} \\
 & - \phi_p) c\psi_p s\gamma_{10i} X_i + s(\gamma_{1413i} - \phi_p) s\psi_p (Y_i c\theta_p s\beta_{21i} + s\theta_p (Y_i c\beta_{21i} s\gamma_{10i} - c\gamma_{10i} X_i)))) \\
 G_{21i} &= \frac{1}{V_{58i} V_{59i}} (-s\psi_{65i} V_{58i} X_i (-2\dot{X}_i \psi_{65i} Y_i V_{59i} + Y_i G_{14i} X_i + 2\dot{Y}_i \psi_{65i} V_{59i} X_i) + c\psi_{65i} V_{59i} (X_i Y_i G_{7i} \\
 & - 2\dot{X}_i Y_i V_{58i} X_i + 2Y_i V_{58i} \dot{X}_i^2 - Y_i V_{58i} X_i^2 \psi_{65i}^2 - a_{1312i} V_{58i} X_i (2\theta_p \dot{\psi}_p Y_i c(\gamma_{1413i} - \phi_p) c\psi_p s\beta_{21i} s\theta_p \\
 & + 2\dot{\phi}_p s(\gamma_{1413i} - \phi_p) s\psi_p (\theta_p Y_i s\beta_{21i} s\theta_p + \dot{\psi}_p s\gamma_{10i} X_i) + Y_i s(\gamma_{1413i} - \phi_p) s\beta_{21i} s\theta_p \theta_p^2 + Y_i s(\gamma_{1413i} \\
 & - \phi_p) s\beta_{21i} s\theta_p \phi_p^2 + c(\gamma_{1413i} - \phi_p) c\psi_p s\gamma_{10i} X_i \phi_p^2 + c(\gamma_{1413i} - \phi_p) c\psi_p s\gamma_{10i} X_i \psi_p^2 \\
 & + Y_i c\theta_p s\beta_{21i} (-2\dot{\phi}_p \dot{\psi}_p s(\gamma_{1413i} - \phi_p) c\psi_p + c(\gamma_{1413i} - \phi_p) (2\theta_p \dot{\phi}_p + s\psi_p (\theta_p^2 + \phi_p^2 + \psi_p^2))) \\
 & + c\gamma_{10i} X_i (c\theta_p (2\theta_p \dot{\psi}_p c(\gamma_{1413i} - \phi_p) c\psi_p + s(\gamma_{1413i} - \phi_p) (2\theta_p \dot{\phi}_p s\psi_p + \theta_p^2 + \phi_p^2)) \\
 & + s\theta_p (2\dot{\phi}_p \dot{\psi}_p s(\gamma_{1413i} - \phi_p) c\psi_p - c(\gamma_{1413i} - \phi_p) (2\theta_p \dot{\phi}_p + s\psi_p (\theta_p^2 + \phi_p^2 + \psi_p^2))))
 \end{aligned}$$

$$\begin{aligned}
 & -a_{1312i}Y_i c\beta_{21i}V_{58i}X_i(c\gamma_{10i}(2\phi_p\psi_p s(\gamma_{1413i} - \phi_p)s\psi_p + c(\gamma_{1413i} - \phi_p)c\psi_p(\phi_p^2 + \psi_p^2)) \\
 & + s\gamma_{10i}(c\theta_p(-2\theta_p\psi_p c(\gamma_{1413i} - \phi_p)c\psi_p - s(\gamma_{1413i} - \phi_p)(2\theta_p\phi_p s\psi_p + \theta_p^2 + \phi_p^2)) \\
 & + s\theta_p(-2\phi_p\psi_p s(\gamma_{1413i} - \phi_p)c\psi_p + c(\gamma_{1413i} - \phi_p)(2\theta_p\phi_p + s\psi_p(\theta_p^2 + \phi_p^2 + \psi_p^2)))) \\
 & - 2\phi_{76i}^2 \sec^2(\phi_{76i})V_{58i}V_{59i}X_i^3 \tan(\phi_{76i})
 \end{aligned}$$

Coefficientes de la ecuación X.XX

$$V_{61i} = -\frac{\cos^2(\phi_{1110i})}{a_{31i}^3}$$

$$\begin{aligned}
 G_{22i} = & \frac{1}{V_{59i}} a_{31i} G_{8i} (c(\beta_{21i} + \psi_{65i})(-a_{32i}c(\gamma_{1211i} + \gamma_{1413i} - \phi_p) + a_{31i}s(\gamma_{1211i} + \gamma_{1413i} - \phi_p))c\gamma_{10i}c\psi_p \\
 & + (a_{31i}c(\gamma_{1211i} + \gamma_{1413i} - \phi_p) + a_{32i}s(\gamma_{1211i} + \gamma_{1413i} - \phi_p))(c(\beta_{21i} + \psi_{65i})c\theta_p s\gamma_{10i} - s(\beta_{21i} \\
 & + \psi_{65i})s\theta_p) - (a_{32i}c(\gamma_{1211i} + \gamma_{1413i} - \phi_p) - a_{31i}s(\gamma_{1211i} + \gamma_{1413i} - \phi_p))(s(\beta_{21i} + \psi_{65i})c\theta_p \\
 & + c(\beta_{21i} + \psi_{65i})s\gamma_{10i}s\theta_p)s\psi_p)
 \end{aligned}$$

$$\begin{aligned}
 G_{23i} = & \frac{1}{V_{59i}} a_{31i} G_{9i} (c(\beta_{21i} + \psi_{65i})(-a_{32i}c(\gamma_{1211i} + \gamma_{1413i} - \phi_p) + a_{31i}s(\gamma_{1211i} + \gamma_{1413i} - \phi_p))c\gamma_{10i}c\psi_p \\
 & + (a_{31i}c(\gamma_{1211i} + \gamma_{1413i} - \phi_p) + a_{32i}s(\gamma_{1211i} + \gamma_{1413i} - \phi_p))(c(\beta_{21i} + \psi_{65i})c\theta_p s\gamma_{10i} - s(\beta_{21i} \\
 & + \psi_{65i})s\theta_p) - (a_{32i}c(\gamma_{1211i} + \gamma_{1413i} - \phi_p) - a_{31i}s(\gamma_{1211i} + \gamma_{1413i} - \phi_p))(s(\beta_{21i} + \psi_{65i})c\theta_p \\
 & + c(\beta_{21i} + \psi_{65i})s\gamma_{10i}s\theta_p)s\psi_p)
 \end{aligned}$$

$$\begin{aligned}
 G_{24i} = & \frac{1}{V_{59i}} a_{31i} G_{10i} (c(\beta_{21i} + \psi_{65i})(-a_{31i}c(\gamma_{1211i} + \gamma_{1413i} - \phi_p) + a_{31i}s(\gamma_{1211i} + \gamma_{1413i} - \phi_p))c\gamma_{10i}c\psi_p \\
 & + (a_{31i}c(\gamma_{1211i} + \gamma_{1413i} - \phi_p) + a_{31i}s(\gamma_{1211i} + \gamma_{1413i} - \phi_p))(c(\beta_{21i} + \psi_{65i})c\theta_p s\gamma_{10i} - s(\beta_{21i} \\
 & + \psi_{65i})s\theta_p) - (a_{31i}c(\gamma_{1211i} + \gamma_{1413i} - \phi_p) - a_{31i}s(\gamma_{1211i} + \gamma_{1413i} - \phi_p))(s(\beta_{21i} + \psi_{65i})c\theta_p \\
 & + c(\beta_{21i} + \psi_{65i})s\gamma_{10i}s\theta_p)s\psi_p)
 \end{aligned}$$

$$\begin{aligned}
 G_{25i} = & \frac{1}{4V_{59i}} a_{31i} (4c(\beta_{21i} + \psi_{65i})(-a_{32i}c(\gamma_{1211i} + \gamma_{1413i} - \phi_p) + a_{31i}s(\gamma_{1211i} + \gamma_{1413i} \\
 & - \phi_p))c\gamma_{10i}c\psi_p G_{11i} + 2(a_{31i}c(\gamma_{1211i} + \gamma_{1413i} - \phi_p) + a_{32i}s(\gamma_{1211i} + \gamma_{1413i} - \phi_p))(c(\beta_{21i} - \theta_p \\
 & + \psi_{65i})(-1 + s\gamma_{10i})(G_{11i} - V_{59i}) + c(\beta_{21i} + \theta_p + \psi_{65i})(1 + s\gamma_{10i})(G_{11i} + V_{59i})) + (a_{32i}c(\gamma_{1211i} \\
 & + \gamma_{1413i} - \phi_p) - a_{31i}s(\gamma_{1211i} + \gamma_{1413i} - \phi_p))s\psi_p(-4c(\beta_{21i} + \psi_{65i})s\theta_p(G_{11i}s\gamma_{10i} + V_{59i}) \\
 & - 4s(\beta_{21i} + \psi_{65i})c\theta_p(G_{11i} + s\gamma_{10i}V_{59i}))
 \end{aligned}$$

$$\begin{aligned}
 G_{26i} = & \frac{1}{V_{59i}} a_{31i} (-a_{32i}c(\gamma_{1211i} + \gamma_{1413i} - \phi_p) - a_{31i}s(\gamma_{1211i} + \gamma_{1413i} - \phi_p))c\gamma_{10i}(c(\beta_{21i} + \psi_{65i})c\psi_p G_{12i} \\
 & - s(\beta_{21i} + \psi_{65i})s\psi_p V_{59i}) + c\theta_p (s(\gamma_{1211i} + \gamma_{1413i} - \phi_p)(a_{31i}s(\beta_{21i} + \psi_{65i})G_{12i}s\psi_p + c(\beta_{21i} \\
 & + \psi_{65i})(a_{32i}G_{12i}s\gamma_{10i} - a_{31i}c\psi_p V_{59i})) + c(\gamma_{1211i} + \gamma_{1413i} - \phi_p)(-a_{32i}s(\beta_{21i} + \psi_{65i})G_{12i}s\psi_p \\
 & + c(\beta_{21i} + \psi_{65i})(a_{31i}G_{12i}s\gamma_{10i} + a_{32i}c\psi_p V_{59i}))) + s\theta_p (s(\gamma_{1211i} + \gamma_{1413i} - \phi_p)(a_{31i}c(\beta_{21i} \\
 & + \psi_{65i})G_{12i}s\gamma_{10i}s\psi_p + s(\beta_{21i} + \psi_{65i})(-a_{32i}G_{12i} + a_{31i}c\psi_p s\gamma_{10i}V_{59i})) - c(\gamma_{1211i} + \gamma_{1413i} \\
 & - \phi_p)(a_{32i}c(\beta_{21i} + \psi_{65i})G_{12i}s\gamma_{10i}s\psi_p + s(\beta_{21i} + \psi_{65i})(a_{31i}G_{12i} + a_{32i}c\psi_p s\gamma_{10i}V_{59i})))
 \end{aligned}$$

$$\begin{aligned}
 G_{27i} = & -\frac{1}{V_{59i}} a_{31i} (c\gamma_{10i}c\psi_p (c(\gamma_{1211i} + \gamma_{1413i} - \phi_p)(a_{32i}c(\beta_{21i} + \psi_{65i})G_{13i} + a_{31i}s(\beta_{21i} + \psi_{65i})V_{59i}) \\
 & + s(\gamma_{1211i} + \gamma_{1413i} - \phi_p)(-a_{31i}c(\beta_{21i} + \psi_{65i})G_{13i} + a_{32i}s(\beta_{21i} + \psi_{65i})V_{59i})) + c(\gamma_{1211i} \\
 & + \gamma_{1413i})(s(\beta_{21i} + \psi_{65i})(G_{13i}s\theta_p(a_{31i}c\phi_p - a_{32i}s\phi_p) + c\theta_p s\gamma_{10i}(a_{32i}c\phi_p + a_{31i}s\phi_p)V_{59i}) \\
 & + c(\beta_{21i} + \psi_{65i})(c\theta_p G_{13i}s\gamma_{10i}(-a_{31i}c\phi_p + a_{32i}s\phi_p) + s\theta_p(a_{32i}c\phi_p + a_{31i}s\phi_p)V_{59i})) + s(\gamma_{1211i} \\
 & + \gamma_{1413i})(s(\beta_{21i} + \psi_{65i})(G_{13i}s\theta_p(a_{32i}c\phi_p + a_{31i}s\phi_p) + c\theta_p s\gamma_{10i}(-a_{31i}c\phi_p + a_{32i}s\phi_p)V_{59i}) \\
 & + c(\beta_{21i} + \psi_{65i})(-c\theta_p G_{13i}s\gamma_{10i}(a_{32i}c\phi_p + a_{31i}s\phi_p) + s\theta_p(-a_{31i}c\phi_p + a_{32i}s\phi_p)V_{59i})) \\
 & + s\psi_p (c(\beta_{21i} + \psi_{65i})(c(\gamma_{1211i} + \gamma_{1413i} - \phi_p)(a_{32i}G_{13i}s\gamma_{10i}s\theta_p - a_{31i}c\theta_p V_{59i}) - s(\gamma_{1211i} + \gamma_{1413i} \\
 & - \phi_p)(a_{31i}G_{13i}s\gamma_{10i}s\theta_p + a_{32i}c\theta_p V_{59i})) + s(\beta_{21i} + \psi_{65i})(c(\gamma_{1211i} + \gamma_{1413i} - \phi_p)(a_{32i}c\theta_p G_{13i} \\
 & + a_{31i}s\gamma_{10i}s\theta_p V_{59i}) + s(\gamma_{1211i} + \gamma_{1413i} - \phi_p)(-a_{31i}c\theta_p G_{13i} + a_{32i}s\gamma_{10i}s\theta_p V_{59i}))))
 \end{aligned}$$

$$\begin{aligned}
 G_{28i} = & \frac{1}{V_{59i}} (V_{59i}(-2a_{31i}\dot{a}_{31i}\ddot{a}_{32i} + \ddot{x}_p G_{22i} + \ddot{y}_p G_{23i} + \ddot{z}_p G_{24i} + \ddot{\theta}_p G_{25i} + \ddot{\psi}_p G_{26i} + \ddot{\phi}_p G_{27i} + 2a_{32i}\dot{a}_{31i}^2) \\
 & + a_{31i}c(\gamma_{1211i} + \gamma_{1413i})(s\theta_p(s(\beta_{21i} + \psi_{65i})(-a_{31i}c\phi_p G_{14i} + a_{32i}G_{14i}s\phi_p + 2a_{32i}\dot{\phi}_p\psi_{65i}c\phi_p V_{59i} \\
 & + 2a_{31i}\dot{\phi}_p\psi_{65i}s\phi_p V_{59i} + 2\theta_p\phi_p s\gamma_{10i}(a_{32i}c\phi_p + a_{31i}s\phi_p)V_{59i}) - c(\beta_{21i} + \psi_{65i})(a_{31i}c\phi_p \\
 & - a_{32i}s\phi_p)V_{59i}(2\theta_p\psi_{65i}s\gamma_{10i} + \theta_p^2 + \phi_p^2 + \psi_{65i}^2)) + c\theta_p(c(\beta_{21i} + \psi_{65i})(-2\theta_p\phi_p(a_{32i}c\phi_p \\
 & + a_{31i}s\phi_p)V_{59i} + s\gamma_{10i}(-s\phi_p(a_{32i}G_{14i} + 2a_{31i}\dot{\phi}_p\psi_{65i}V_{59i}) + c\phi_p(a_{31i}G_{14i} - 2a_{32i}\dot{\phi}_p\psi_{65i}V_{59i}))) \\
 & - s(\beta_{21i} + \psi_{65i})(a_{31i}c\phi_p - a_{32i}s\phi_p)V_{59i}(2\theta_p\psi_{65i} + s\gamma_{10i}(\theta_p^2 + \phi_p^2 + \psi_{65i}^2))) \\
 & + c\gamma_{10i}(2\psi_p(\psi_{65i}c(\beta_{21i} + \psi_{65i})(a_{32i}c\phi_p + a_{31i}s\phi_p) + \dot{\phi}_p s(\beta_{21i} + \psi_{65i})(a_{31i}c\phi_p \\
 & - a_{32i}s\phi_p))s\psi_p V_{59i} + c\psi_p(-c(\beta_{21i} + \psi_{65i})(a_{32i}c\phi_p G_{14i} + a_{31i}G_{14i}s\phi_p + 2a_{31i}\dot{\phi}_p\psi_{65i}c\phi_p V_{59i} \\
 & - 2a_{32i}\dot{\phi}_p\psi_{65i}s\phi_p V_{59i}) + s(\beta_{21i} + \psi_{65i})(a_{32i}c\phi_p + a_{31i}s\phi_p)V_{59i}(\phi_p^2 + \psi_{65i}^2 + \psi_p^2))) \\
 & + a_{31i}c\theta_p(a_{31i}c(\beta_{21i} + \psi_{65i})s(\gamma_{1211i} + \gamma_{1413i})G_{14i}s\gamma_{10i}s\phi_p + 2a_{32i}\dot{\phi}_p\psi_p c(\beta_{21i} + \psi_{65i})s(\gamma_{1211i} \\
 & + \gamma_{1413i} - \phi_p)c\psi_p V_{59i} + 2a_{31i}\psi_{65i}\psi_p s(\gamma_{1211i} + \gamma_{1413i} - \phi_p)s(\beta_{21i} + \psi_{65i})c\psi_p V_{59i} \\
 & + 2a_{31i}\dot{\theta}_p\psi_p s(\gamma_{1211i} + \gamma_{1413i} - \phi_p)s(\beta_{21i} + \psi_{65i})c\psi_p s\gamma_{10i}V_{59i} - 2a_{32i}\dot{\theta}_p\phi_p c(\beta_{21i} + \psi_{65i})s(\gamma_{1211i} \\
 & + \gamma_{1413i})s\phi_p V_{59i} - 2a_{31i}\dot{\theta}_p\psi_{65i}s(\gamma_{1211i} + \gamma_{1413i})s(\beta_{21i} + \psi_{65i})s\phi_p V_{59i} - 2a_{32i}\dot{\phi}_p\psi_{65i}c(\beta_{21i} \\
 & + \psi_{65i})s(\gamma_{1211i} + \gamma_{1413i})s\gamma_{10i}s\phi_p V_{59i} - a_{31i}s(\gamma_{1211i} + \gamma_{1413i})s(\beta_{21i} + \psi_{65i})s\gamma_{10i}s\phi_p V_{59i}\theta_p^2 \\
 & - a_{31i}s(\gamma_{1211i} + \gamma_{1413i})s(\beta_{21i} + \psi_{65i})s\gamma_{10i}s\phi_p V_{59i}\phi_p^2 - a_{31i}s(\gamma_{1211i} + \gamma_{1413i})s(\beta_{21i} \\
 & + \psi_{65i})s\gamma_{10i}s\phi_p V_{59i}\psi_{65i}^2 + s(\gamma_{1211i} + \gamma_{1413i})c\phi_p(c(\beta_{21i} + \psi_{65i})(a_{32i}G_{14i}s\gamma_{10i} + 2a_{31i}\dot{\theta}_p\phi_p V_{59i} \\
 & + 2a_{31i}\dot{\phi}_p\psi_{65i}s\gamma_{10i}V_{59i}) - a_{32i}s(\beta_{21i} + \psi_{65i})V_{59i}(2\theta_p\psi_{65i} + s\gamma_{10i}(\theta_p^2 + \phi_p^2 + \psi_{65i}^2))) \\
 & + s(\gamma_{1211i} + \gamma_{1413i} - \phi_p)s\psi_p(s(\beta_{21i} + \psi_{65i})(a_{31i}G_{14i} - 2a_{32i}\dot{\phi}_p\psi_{65i}V_{59i} - 2a_{32i}\dot{\theta}_p\phi_p s\gamma_{10i}V_{59i}) \\
 & + a_{31i}c(\beta_{21i} + \psi_{65i})V_{59i}(2\theta_p\psi_{65i}s\gamma_{10i} + \theta_p^2 + \phi_p^2 + \psi_{65i}^2 + \psi_p^2)) + c(\gamma_{1211i} + \gamma_{1413i} - \phi_p)(s(\beta_{21i} \\
 & + \psi_{65i})(-2a_{32i}\psi_p c\psi_p(\psi_{65i} + \theta_p s\gamma_{10i})V_{59i} - s\psi_p(a_{32i}G_{14i} + 2a_{31i}\dot{\phi}_p\psi_{65i}V_{59i} \\
 & + 2a_{31i}\dot{\theta}_p\phi_p s\gamma_{10i}V_{59i})) + c(\beta_{21i} + \psi_{65i})V_{59i}(2a_{31i}\dot{\phi}_p\psi_p c\psi_p - a_{32i}s\psi_p(2\theta_p\psi_{65i}s\gamma_{10i} + \theta_p^2 + \phi_p^2 \\
 & + \psi_{65i}^2 + \psi_p^2))) + a_{31i}(-a_{32i}s(\gamma_{1211i} + \gamma_{1413i})s(\beta_{21i} + \psi_{65i})c\phi_p G_{14i}s\theta_p - a_{31i}s(\gamma_{1211i} \\
 & + \gamma_{1413i})s(\beta_{21i} + \psi_{65i})G_{14i}s\theta_p s\phi_p + a_{31i}c(\beta_{21i} + \psi_{65i})s(\gamma_{1211i} + \gamma_{1413i} - \phi_p)G_{14i}s\gamma_{10i}s\theta_p s\psi_p \\
 & - 2a_{31i}\dot{\phi}_p\psi_{65i}s(\gamma_{1211i} + \gamma_{1413i})s(\beta_{21i} + \psi_{65i})c\phi_p s\theta_p V_{59i} + 2a_{31i}\dot{\theta}_p\psi_p c(\beta_{21i} + \psi_{65i})s(\gamma_{1211i} \\
 & + \gamma_{1413i} - \phi_p)c\psi_p s\theta_p V_{59i} - 2a_{32i}\dot{\theta}_p\psi_{65i}c(\beta_{21i} + \psi_{65i})s(\gamma_{1211i} + \gamma_{1413i})c\phi_p s\gamma_{10i}s\theta_p V_{59i} \\
 & - 2a_{31i}\dot{\theta}_p\phi_p s(\gamma_{1211i} + \gamma_{1413i})s(\beta_{21i} + \psi_{65i})c\phi_p s\gamma_{10i}s\theta_p V_{59i} + 2a_{31i}\psi_{65i}\psi_p c(\beta_{21i} + \psi_{65i})s(\gamma_{1211i} \\
 & + \gamma_{1413i} - \phi_p)c\psi_p s\gamma_{10i}s\theta_p V_{59i} - 2a_{32i}\dot{\phi}_p\psi_p s(\gamma_{1211i} + \gamma_{1413i} - \phi_p)s(\beta_{21i} + \psi_{65i})c\psi_p s\gamma_{10i}s\theta_p V_{59i} \\
 & + 2a_{32i}\dot{\phi}_p\psi_{65i}s(\gamma_{1211i} + \gamma_{1413i})s(\beta_{21i} + \psi_{65i})s\theta_p s\phi_p V_{59i} - 2a_{31i}\dot{\theta}_p\psi_{65i}c(\beta_{21i} + \psi_{65i})s(\gamma_{1211i} \\
 & + \gamma_{1413i})s\gamma_{10i}s\theta_p s\phi_p V_{59i} + 2a_{32i}\dot{\theta}_p\phi_p s(\gamma_{1211i} + \gamma_{1413i})s(\beta_{21i} + \psi_{65i})s\gamma_{10i}s\theta_p s\phi_p V_{59i} \\
 & - 2a_{32i}\dot{\theta}_p\phi_p c(\beta_{21i} + \psi_{65i})s(\gamma_{1211i} + \gamma_{1413i} - \phi_p)s\theta_p s\psi_p V_{59i} - 2a_{31i}\dot{\theta}_p\psi_{65i}s(\gamma_{1211i} + \gamma_{1413i} \\
 & - \phi_p)s(\beta_{21i} + \psi_{65i})s\theta_p s\psi_p V_{59i} - 2a_{32i}\dot{\phi}_p\psi_{65i}c(\beta_{21i} + \psi_{65i})s(\gamma_{1211i} + \gamma_{1413i} \\
 & - \phi_p)s\gamma_{10i}s\theta_p s\psi_p V_{59i} - a_{32i}c(\beta_{21i} + \psi_{65i})s(\gamma_{1211i} + \gamma_{1413i})c\phi_p s\theta_p V_{59i}\theta_p^2 - a_{31i}c(\beta_{21i} \\
 & + \psi_{65i})s(\gamma_{1211i} + \gamma_{1413i})s\theta_p s\phi_p V_{59i}\theta_p^2 - a_{31i}s(\gamma_{1211i} + \gamma_{1413i} - \phi_p)s(\beta_{21i} \\
 & + \psi_{65i})s\gamma_{10i}s\theta_p s\psi_p V_{59i}\theta_p^2 - a_{32i}c(\beta_{21i} + \psi_{65i})s(\gamma_{1211i} + \gamma_{1413i})c\phi_p s\theta_p V_{59i}\phi_p^2 - a_{31i}c(\beta_{21i} \\
 & + \psi_{65i})s(\gamma_{1211i} + \gamma_{1413i})s\theta_p s\phi_p V_{59i}\phi_p^2 - a_{31i}s(\gamma_{1211i} + \gamma_{1413i} - \phi_p)s(\beta_{21i} \\
 & + \psi_{65i})s\gamma_{10i}s\theta_p s\psi_p V_{59i}\phi_p^2 - a_{32i}c(\beta_{21i} + \psi_{65i})s(\gamma_{1211i} + \gamma_{1413i})c\phi_p s\theta_p V_{59i}\psi_{65i}^2 - a_{31i}c(\beta_{21i} \\
 & + \psi_{65i})s(\gamma_{1211i} + \gamma_{1413i})s\theta_p s\phi_p V_{59i}\psi_{65i}^2 - a_{31i}s(\gamma_{1211i} + \gamma_{1413i} - \phi_p)s(\beta_{21i} + \psi_{65i})s\gamma_{10i}s\theta_p s\psi_p V_{59i}\psi_p^2 \\
 & + s(\gamma_{1211i} + \gamma_{1413i})c\gamma_{10i}(2\psi_p(\dot{\phi}_p s(\beta_{21i} + \psi_{65i})(a_{32i}c\phi_p + a_{31i}s\phi_p) + \psi_{65i}c(\beta_{21i} \\
 & + \psi_{65i}))(-a_{31i}c\phi_p + a_{32i}s\phi_p))s\psi_p V_{59i} + c\psi_p(c(\beta_{21i} + \psi_{65i})(-s\phi_p(a_{32i}G_{14i} + 2a_{31i}\dot{\phi}_p\psi_{65i}V_{59i}) \\
 & + c\phi_p(a_{31i}G_{14i} - 2a_{32i}\dot{\phi}_p\psi_{65i}V_{59i})) - s(\beta_{21i} + \psi_{65i})(a_{31i}c\phi_p - a_{32i}s\phi_p)V_{59i}(\phi_p^2 + \psi_{65i}^2 + \psi_p^2))) \\
 & + c(\gamma_{1211i} + \gamma_{1413i} - \phi_p)s\theta_p(c(\beta_{21i} + \psi_{65i})(-2a_{32i}\psi_p c\psi_p(\theta_p + \psi_{65i}s\gamma_{10i})V_{59i} \\
 & - s\psi_p(a_{32i}G_{14i}s\gamma_{10i} + 2a_{31i}\dot{\theta}_p\phi_p V_{59i} + 2a_{31i}\dot{\phi}_p\psi_{65i}s\gamma_{10i}V_{59i}) + s(\beta_{21i} + \psi_{65i})V_{59i}
 \end{aligned}$$

Coeficientes de la ecuación X.XX

$$V_{62i} = -\frac{\cos^2(\psi_{109i})}{a_{33i}^3}$$

$$G_{22i} = -\frac{1}{V_{59i}} a_{33i} \csc(\phi_{1110i}) G_{8i} (a_{32i} s(\beta_{21i} + \psi_{65i}) c\theta_p c\psi_p + a_{32i} c(\beta_{21i} + \psi_{65i}) c\psi_p s\gamma_{10i} s\theta_p + a_{33i} c(\beta_{21i} + \psi_{65i}) s(\gamma_{1211i} + \gamma_{1413i}) c\theta_p s\gamma_{10i} s\phi_p - a_{33i} s(\gamma_{1211i} + \gamma_{1413i}) s(\beta_{21i} + \psi_{65i}) s\theta_p s\phi_p + a_{33i} c(\gamma_{1211i} + \gamma_{1413i}) (-s(\beta_{21i} + \psi_{65i}) c\phi_p s\theta_p + c(\beta_{21i} + \psi_{65i}) (c\theta_p c\phi_p s\gamma_{10i} - c\gamma_{10i} c\psi_p s\phi_p)) + a_{33i} s(\gamma_{1211i} + \gamma_{1413i} - \phi_p) (s(\beta_{21i} + \psi_{65i}) c\theta_p + c(\beta_{21i} + \psi_{65i}) s\gamma_{10i} s\theta_p) s\psi_p + c(\beta_{21i} + \psi_{65i}) c\gamma_{10i} (a_{33i} s(\gamma_{1211i} + \gamma_{1413i}) c\phi_p c\psi_p - a_{32i} s\psi_p))$$

Apéndice D

Desarrollo de la Ecuación de Lazo

Con el fin de obtener el término $\frac{\partial \theta_i}{\partial q_j}$, el cual se presenta en la ecuación (3.72), se procederá a generar una ecuación de lazo que nos permitirá relacionar el vector de derivadas parciales respecto a q_j de los ángulos x_{32i} , ψ_{65i} y ϕ_{76i} con la derivada parcial respecto a q_j del vector de coordenadas generalizadas, esto es:

$$J_i \frac{\partial \theta_i}{\partial q_j} = J_j \frac{\partial q}{\partial q_j}$$

Ecuación de lazo

Para la obtención de dicha expresión, se requiere obtener una ecuación escalar que se encuentre únicamente en función de los desplazamientos y ángulos conocidos (propios de la estructura del mecanismo). Por tal motivo, se tuvo que emplear la construcción de lazos vectoriales, tal y como se muestra en la Figura D.1.

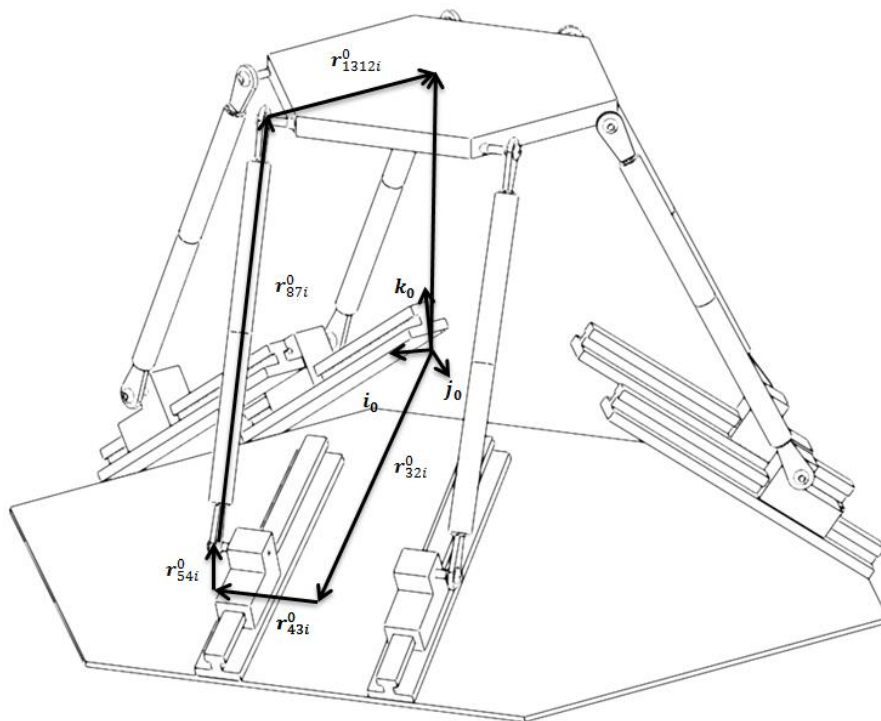

Fig. D.1 Ecuación de Lazo

A continuación se la ecuación de lazo obtenida a partir del esquema anterior.

$$\mathbf{r}_{32i}^0 + \mathbf{r}_{43i}^0 + \mathbf{r}_{54i}^0 + \mathbf{r}_{87i}^0 = \mathbf{r}_p^0 - \mathbf{r}_{1312i}^0 \quad (\text{D.1})$$

Dónde:

$$\begin{aligned} \mathbf{r}_{32i}^0 &= \mathbf{R}_{2i}^0 \mathbf{r}_{32i}^2 & \mathbf{r}_{32i}^3 &= [x_{32i}, 0, 0]^T \\ \mathbf{r}_{43i}^0 &= \mathbf{R}_{2i}^0 \mathbf{r}_{43i}^3 & \mathbf{r}_{43i}^3 &= [0, \pm b_{43i}, 0]^T \\ \mathbf{r}_{54i}^0 &= \mathbf{R}_{2i}^0 \mathbf{r}_{54i}^4 & \mathbf{r}_{54i}^4 &= [0, 0, c_{54i}]^T \\ \mathbf{r}_{87i}^0 &= \mathbf{R}_{7i}^0 \mathbf{r}_{87i}^7 & \mathbf{r}_{87i}^4 &= [a_{87i}, 0, 0]^T \\ \mathbf{r}_{1312i}^0 &= \mathbf{R}_{1312i}^0 \mathbf{r}_{1312i}^{12} & \mathbf{r}_{1312i}^{12} &= [a_{1312i}, 0, 0]^T \\ \mathbf{r}_p^0 &= [x_p, y_p, z_p]^T \end{aligned}$$

$$\begin{aligned} \mathbf{R}_{2i}^0 &= \mathbf{R}_z(\gamma_{10i}) \mathbf{R}_y(\beta_{21i}) \\ \mathbf{R}_{7i}^0 &= \mathbf{R}_z(\gamma_{10i}) \mathbf{R}_y(\beta_{21i}) \mathbf{R}_y(\psi_{65i}) \mathbf{R}_z(\phi_{76i}) = \mathbf{R}_{2i}^0 \mathbf{R}_y(\psi_{65i}) \mathbf{R}_z(\phi_{76i}) \\ \mathbf{R}_{1312i}^0 &= \mathbf{R}_x(\theta_p) \mathbf{R}_y(\psi_p) \mathbf{R}_z(\phi_p) \mathbf{R}_z(-\gamma_{1413i}) \end{aligned}$$

Derivando la ec. (1) respecto a q_j :

$$\begin{aligned} \frac{\partial}{\partial q_j} (\mathbf{r}_{32i}^0 + \mathbf{r}_{43i}^0 + \mathbf{r}_{54i}^0 + \mathbf{r}_{87i}^0) &= \frac{\partial}{\partial q_j} (\mathbf{r}_p^0 - \mathbf{r}_{1312i}^0) \\ \frac{\partial \mathbf{r}_{32i}^0}{\partial q_j} + \frac{\partial \mathbf{r}_{43i}^0}{\partial q_j} + \frac{\partial \mathbf{r}_{54i}^0}{\partial q_j} + \frac{\partial \mathbf{r}_{87i}^0}{\partial q_j} &= \frac{\partial \mathbf{r}_p^0}{\partial q_j} - \frac{\partial \mathbf{r}_{1312i}^0}{\partial q_j} \end{aligned} \quad (\text{D.2})$$

Obteniendo cada uno de los componentes de la ecuación anterior:

$$\begin{aligned} \frac{\partial \mathbf{r}_{32i}^0}{\partial q_j} &= \left(\mathbf{R}_{2i}^0 \frac{\partial \mathbf{r}_{32i}^2}{\partial x_{32i}} \right) \frac{\partial x_{32i}}{\partial q_j} = \mathbf{J}_{1i} \frac{\partial x_{32i}}{\partial q_j} \\ \frac{\partial \mathbf{r}_{43i}^0}{\partial q_j} &= \mathbf{0} \\ \frac{\partial \mathbf{r}_{54i}^0}{\partial q_j} &= \mathbf{0} \\ \frac{\partial \mathbf{r}_{87i}^0}{\partial q_j} &= \frac{\partial \mathbf{R}_{7i}^0}{\partial q_j} \mathbf{r}_{87i}^7 \\ &= \left(\frac{\partial \mathbf{R}_{2i}^0}{\partial q_j} \mathbf{R}_y(\psi_{65i}) \mathbf{R}_z(\phi_{76i}) + \mathbf{R}_{2i}^0 \frac{\partial \mathbf{R}_y(\psi_{65i})}{\partial q_j} \mathbf{R}_z(\phi_{76i}) + \mathbf{R}_{2i}^0 \mathbf{R}_y(\psi_{65i}) \frac{\partial \mathbf{R}_z(\phi_{76i})}{\partial q_j} \right) \mathbf{r}_{87i}^7 \\ &= \left(\mathbf{R}_{2i}^0 \frac{\partial \mathbf{R}_y(\psi_{65i})}{\partial \psi_{65i}} \frac{\partial \psi_{65i}}{\partial q_j} \mathbf{R}_z(\phi_{76i}) + \mathbf{R}_{2i}^0 \mathbf{R}_y(\psi_{65i}) \frac{\partial \mathbf{R}_z(\phi_{76i})}{\partial \phi_{76i}} \frac{\partial \phi_{76i}}{\partial q_j} \right) \mathbf{r}_{87i}^7 \end{aligned}$$

$$\begin{aligned}
 &= \mathbf{R}_{2i}^0 \mathbf{B}_y(\psi_{65i}) \mathbf{R}_z(\phi_{76i}) \mathbf{r}_{87i}^7 \frac{\partial \psi_{65i}}{\partial q_j} + \mathbf{R}_{2i}^0 \mathbf{R}_y(\psi_{65i}) \mathbf{B}_z(\phi_{76i}) \mathbf{r}_{87i}^7 \frac{\partial \phi_{76i}}{\partial q_j} \\
 &= \mathbf{J}_{2i} \frac{\partial \psi_{65i}}{\partial q_j} + \mathbf{J}_{3i} \frac{\partial \phi_{76i}}{\partial q_j}
 \end{aligned}$$

$$\begin{aligned}
 \frac{\partial \mathbf{r}_{1312i}^0}{\partial q_j} &= \frac{\partial \mathbf{R}_{1312i}^0}{\partial q_j} \mathbf{r}_{1312i}^{12} \\
 &= \left(\frac{\partial \mathbf{R}_x(\theta_p)}{\partial q_j} \mathbf{R}_y(\psi_p) \mathbf{R}_z(\phi_p) \mathbf{R}_z(-\gamma_{1413i}) + \mathbf{R}_x(\theta_p) \frac{\partial \mathbf{R}_y(\psi_p)}{\partial q_j} \mathbf{R}_z(\phi_p) \mathbf{R}_z(-\gamma_{1413i}) \right. \\
 &+ \mathbf{R}_x(\theta_p) \mathbf{R}_y(\psi_p) \frac{\partial \mathbf{R}_z(\phi_p)}{\partial q_j} \mathbf{R}_z(-\gamma_{1413i}) + \mathbf{R}_x(\theta_p) \mathbf{R}_y(\psi_p) \mathbf{R}_z(\phi_p) \frac{\partial \mathbf{R}_z(-\gamma_{1413i})}{\partial q_j} \left. \right) \mathbf{r}_{1312i}^{12} \\
 &= \left(\frac{\partial \mathbf{R}_x(\theta_p)}{\partial \theta_p} \frac{\partial \theta_p}{\partial q_j} \mathbf{R}_y(\psi_p) \mathbf{R}_z(\phi_p) \mathbf{R}_z(-\gamma_{1413i}) + \mathbf{R}_x(\theta_p) \frac{\partial \mathbf{R}_y(\psi_p)}{\partial \psi_p} \frac{\partial \psi_p}{\partial q_j} \mathbf{R}_z(\phi_p) \mathbf{R}_z(-\gamma_{1413i}) \right. \\
 &+ \left. \mathbf{R}_x(\theta_p) \mathbf{R}_y(\psi_p) \frac{\partial \mathbf{R}_z(\phi_p)}{\partial \phi_p} \frac{\partial \phi_p}{\partial q_j} \mathbf{R}_z(-\gamma_{1413i}) \right) \mathbf{r}_{1312i}^{12} \\
 &= \mathbf{B}_x(\theta_p) \mathbf{R}_y(\psi_p) \mathbf{R}_z(\phi_p) \mathbf{R}_z(-\gamma_{1413i}) \mathbf{r}_{1312i}^{12} \frac{\partial \theta_p}{\partial q_j} + \mathbf{R}_x(\theta_p) \mathbf{B}_y(\psi_p) \mathbf{R}_z(\phi_p) \mathbf{R}_z(-\gamma_{1413i}) \mathbf{r}_{1312i}^{12} \frac{\partial \psi_p}{\partial q_j} \\
 &+ \mathbf{R}_x(\theta_p) \mathbf{R}_y(\psi_p) \mathbf{B}_z(\phi_p) \mathbf{R}_z(-\gamma_{1413i}) \mathbf{r}_{1312i}^{12} \frac{\partial \phi_p}{\partial q_j} \\
 &= \mathbf{J}_{4i} \frac{\partial \theta_p}{\partial q_j} + \mathbf{J}_{5i} \frac{\partial \psi_p}{\partial q_j} + \mathbf{J}_{6i} \frac{\partial \phi_p}{\partial q_j}
 \end{aligned}$$

Sustituyendo los últimos resultados en la ec. (D.1):

$$\mathbf{J}_{1i} \frac{\partial x_{32i}}{\partial q_j} + \mathbf{J}_{2i} \frac{\partial \psi_{65i}}{\partial q_j} + \mathbf{J}_{3i} \frac{\partial \phi_{76i}}{\partial q_j} = \frac{\partial \mathbf{r}_p^0}{\partial q_j} - \mathbf{J}_{4i} \frac{\partial \theta_p}{\partial q_j} - \mathbf{J}_{5i} \frac{\partial \psi_p}{\partial q_j} - \mathbf{J}_{6i} \frac{\partial \phi_p}{\partial q_j}$$

Acomodando matricialmente:

$$\begin{bmatrix} \mathbf{J}_{1i} & \mathbf{J}_{2i} & \mathbf{J}_{3i} \end{bmatrix} \begin{bmatrix} \frac{\partial x_{32i}}{\partial q_j} \\ \frac{\partial \psi_{65i}}{\partial q_j} \\ \frac{\partial \phi_{76i}}{\partial q_j} \end{bmatrix} = \begin{bmatrix} \mathbf{I}_{3 \times 3} & -\mathbf{J}_{4i} & -\mathbf{J}_{5i} & -\mathbf{J}_{6i} \end{bmatrix} \begin{bmatrix} \frac{\partial \mathbf{r}_p^0}{\partial q_j} \\ \frac{\partial \theta_p}{\partial q_j} \\ \frac{\partial \psi_p}{\partial q_j} \\ \frac{\partial \phi_p}{\partial q_j} \end{bmatrix}$$

Finalmente se tiene:

$$J_{\theta i} \frac{\partial \theta_i}{\partial q_j} = J_{qi} \frac{\partial q}{\partial q_j} \quad (D.3)$$

Donde:

$$J_{\theta i} = [J_{1i} \quad J_{2i} \quad J_{3i}] \quad J_{qi} = [I_{3x3} \quad -J_{4i} \quad -J_{5i} \quad -J_{6i}]$$

$$\frac{\partial \theta_i}{\partial q_j} = \left[\frac{\partial x_{32i}}{\partial q_j} \quad \frac{\partial \psi_{65i}}{\partial q_j} \quad \frac{\partial \phi_{76i}}{\partial q_j} \right]^T \quad \frac{\partial q}{\partial q_j} = \left[\frac{\partial r_p^0}{\partial q_j} \quad \frac{\partial \theta_p}{\partial q_j} \quad \frac{\partial \psi_p}{\partial q_j} \quad \frac{\partial \phi_p}{\partial q_j} \right]^T$$

$$J_{1i} = R_{2i}^0 \frac{\partial r_{32i}^2}{\partial x_{32i}}$$

$$J_{2i} = R_{2i}^0 B_y(\psi_{65i}) R_z(\phi_{76i}) r_{87i}^7$$

$$J_{3i} = R_{2i}^0 R_y(\psi_{65i}) B_z(\phi_{76i}) r_{87i}^7$$

$$J_{4i} = B_x(\theta_p) R_y(\psi_p) R_z(\phi_p) R_z(-\gamma_{1413i}) r_{1312i}^{12}$$

$$J_{5i} = R_x(\theta_p) B_y(\psi_p) R_z(\phi_p) R_z(-\gamma_{1413i}) r_{1312i}^{12}$$

$$J_{6i} = R_x(\theta_p) R_y(\psi_p) B_z(\phi_p) R_z(-\gamma_{1413i}) r_{1312i}^{12}$$

Al evaluar el término $\frac{\partial q}{\partial q_j}$, dependerá de qué valor tome el iterador j. De ésta forma, para:

$$j = 1$$

$$\frac{\partial q}{\partial q_1} = \frac{\partial}{\partial q_1} [x_p, y_p, z_p, \theta_p, \psi_p, \phi_p] = \frac{\partial}{\partial x_p} [x_p, y_p, z_p, \theta_p, \psi_p, \phi_p]$$

$$\frac{\partial q}{\partial q_1} = [1, 0, 0, 0, 0, 0]$$

$$j = 2$$

$$\frac{\partial q}{\partial q_2} = \frac{\partial}{\partial q_2} [x_p, y_p, z_p, \theta_p, \psi_p, \phi_p] = \frac{\partial}{\partial y_p} [x_p, y_p, z_p, \theta_p, \psi_p, \phi_p]$$

$$\frac{\partial q}{\partial q_2} = [0, 1, 0, 0, 0, 0]$$

$$j = 3$$

$$\frac{\partial q}{\partial q_3} = \frac{\partial}{\partial q_3} [x_p, y_p, z_p, \theta_p, \psi_p, \phi_p] = \frac{\partial}{\partial z_p} [x_p, y_p, z_p, \theta_p, \psi_p, \phi_p]$$

$$\frac{\partial q}{\partial q_3} = [0, 0, 1, 0, 0, 0]$$

$$j = 4$$

$$\frac{\partial \mathbf{q}}{\partial q_4} = \frac{\partial}{\partial q_4} [x_p, y_p, z_p, \theta_p, \psi_p, \phi_p] = \frac{\partial}{\partial \theta_p} [x_p, y_p, z_p, \theta_p, \psi_p, \phi_p]$$

$$\frac{\partial \mathbf{q}}{\partial q_4} = [0, 0, 0, 1, 0, 0]$$

$$j = 5$$

$$\frac{\partial \mathbf{q}}{\partial q_5} = \frac{\partial}{\partial q_5} [x_p, y_p, z_p, \theta_p, \psi_p, \phi_p] = \frac{\partial}{\partial \psi_p} [x_p, y_p, z_p, \theta_p, \psi_p, \phi_p]$$

$$\frac{\partial \mathbf{q}}{\partial q_5} = [0, 0, 0, 0, 1, 0]$$

$$j = 6$$

$$\frac{\partial \mathbf{q}}{\partial q_6} = \frac{\partial}{\partial q_6} [x_p, y_p, z_p, \theta_p, \psi_p, \phi_p] = \frac{\partial}{\partial \phi_p} [x_p, y_p, z_p, \theta_p, \psi_p, \phi_p]$$

$$\frac{\partial \mathbf{q}}{\partial q_6} = [0, 0, 0, 0, 0, 1]$$

Finalmente, para obtener $\frac{\partial \theta_i}{\partial q_j}$, basta con premultiplicar ambos lados de la ec. (D.2) por $\mathbf{J}_{\theta_i}^{-1}$, por lo tanto:

$$\frac{\partial \theta_i}{\partial q_j} = \mathbf{J}_{\theta_i}^{-1} \mathbf{J}_{q_i} \frac{\partial \mathbf{q}}{\partial q_j} \quad (\text{D.3})$$

Apéndice E

Matriz Jacobiana de Velocidad

para x_{32i}

Con el fin de obtener el término $\delta\mathbf{R}$ en función del vector de coordenadas generalizadas, presentado en la ecuación (3.92), se procederá a obtener las matrices Jacobianas de cinemática directa e inversa, útiles para realizar éste proceso de manera sencilla. A partir de la ecuación de lazo (D.1) obtenida en el Apéndice anterior:

$$\mathbf{r}_{32i}^0 + \mathbf{r}_{43i}^0 + \mathbf{r}_{54i}^0 + \mathbf{r}_{87i}^0 = \mathbf{r}_p^0 - \mathbf{r}_{1312i}^0 \quad (\text{D.1})$$

La ecuación de velocidad lineal se obtiene derivando respecto al tiempo la ecuación anterior:

$$\mathbf{v}_{32i}^0 + \mathbf{v}_{43i}^0 + \mathbf{v}_{54i}^0 + \mathbf{v}_{87i}^0 = \mathbf{v}_p^0 - \mathbf{v}_{1312i}^0 \quad (\text{E.1})$$

Donde cada elemento es:

$$\begin{aligned} \mathbf{v}_{32i}^0 &= \dot{x}_{32i} \mathbf{i}_{2i}^0 \\ \mathbf{v}_{43i}^0 &= \mathbf{0} \\ \mathbf{v}_{54i}^0 &= \mathbf{0} \\ \mathbf{v}_{87i}^0 &= \boldsymbol{\omega}_{7i}^0 \times \mathbf{r}_{87i}^0 \\ \mathbf{v}_{1312i}^0 &= \boldsymbol{\omega}_p^0 \times \mathbf{r}_{1312i}^0 \\ \mathbf{v}_p^0 &= [x_p, y_p, z_p]^T \end{aligned} \quad (\text{E.2})$$

Los vectores de velocidad angular absolutos de las bases son:

$$\begin{aligned} \boldsymbol{\omega}_{7i}^0 &= \boldsymbol{\omega}_{65i}^0 + \boldsymbol{\omega}_{76i}^0 \\ \boldsymbol{\omega}_p^0 &= \boldsymbol{\omega}_\theta^0 + \boldsymbol{\omega}_\psi^0 + \boldsymbol{\omega}_\phi^0 \end{aligned} \quad (\text{E.3})$$

Donde cada una de las velocidades angulares es:

$$\begin{aligned} \boldsymbol{\omega}_{65i}^0 &= \mathbf{j}_{5i}^0 \dot{\psi}_{65i} \\ \boldsymbol{\omega}_{76i}^0 &= \mathbf{k}_{6i}^0 \dot{\phi}_{76i} \\ \boldsymbol{\omega}_\theta^0 &= \mathbf{i}_0^0 \dot{\theta}_p \\ \boldsymbol{\omega}_\psi^0 &= \mathbf{j}_{15}^0 \dot{\psi}_p \end{aligned} \quad (\text{E.4})$$

$$\boldsymbol{\omega}_\phi^0 = \mathbf{k}_{16}^0 \dot{\phi}_p$$

Sustituyendo los elementos de las ecs (E.2) en la ec. (E.1):

$$\dot{x}_{32i} \mathbf{i}_{2i}^0 + \boldsymbol{\omega}_{7i}^0 \times \mathbf{r}_{87i}^0 = \mathbf{v}_p^0 - \boldsymbol{\omega}_p^0 \times \mathbf{r}_{1312i}^0$$

Con el fin de eliminar los términos $\dot{\psi}_{65i}$ y $\dot{\phi}_{76i}$ que aparecen en $\boldsymbol{\omega}_{7i}^0$ y dejar la ec. anterior solo en términos de \dot{x}_{32i} , se hará el producto punto por \mathbf{r}_{87i}^0 en ambos lados de la ecuación (Tsai, 1999):

$$\begin{aligned} \mathbf{r}_{87i}^0 \cdot (\dot{x}_{32i} \mathbf{i}_{2i}^0) + \mathbf{r}_{87i}^0 \cdot (\boldsymbol{\omega}_{7i}^0 \times \mathbf{r}_{87i}^0) &= \mathbf{r}_{87i}^0 \cdot \mathbf{v}_p^0 - \mathbf{r}_{87i}^0 \cdot (\boldsymbol{\omega}_p^0 \times \mathbf{r}_{1312i}^0) \\ \dot{x}_{32i} (\mathbf{r}_{87i}^0 \cdot \mathbf{i}_{2i}^0) &= \mathbf{r}_{87i}^0 \cdot \mathbf{v}_p^0 - \mathbf{r}_{87i}^0 \cdot (\boldsymbol{\omega}_p^0 \times \mathbf{r}_{1312i}^0) \end{aligned}$$

Sustituyendo los términos de las ecs. (E.3) y (E.4):

$$\begin{aligned} \dot{x}_{32i} (\mathbf{r}_{87i}^0 \cdot \mathbf{i}_{2i}^0) &= \mathbf{r}_{87i}^0 \cdot \mathbf{v}_p^0 - \mathbf{r}_{87i}^0 \cdot ((\boldsymbol{\omega}_\theta^0 + \boldsymbol{\omega}_\psi^0 + \boldsymbol{\omega}_\phi^0) \times \mathbf{r}_{1312i}^0) \\ \dot{x}_{32i} (\mathbf{r}_{87i}^0 \cdot \mathbf{i}_{2i}^0) &= \mathbf{r}_{87i}^0 \cdot \mathbf{v}_p^0 - \mathbf{r}_{87i}^0 \cdot ((\mathbf{i}_0^0 \dot{\theta}_p + \mathbf{j}_{15}^0 \dot{\psi}_p + \mathbf{k}_{16}^0 \dot{\phi}_p) \times \mathbf{r}_{1312i}^0) \\ \dot{x}_{32i} (\mathbf{r}_{87i}^0 \cdot \mathbf{i}_{2i}^0) &= \mathbf{r}_{87i}^0 \cdot \mathbf{v}_p^0 - \mathbf{r}_{87i}^0 \cdot (\mathbf{i}_0^0 \dot{\theta}_p \times \mathbf{r}_{1312i}^0) - \mathbf{r}_{87i}^0 \cdot (\mathbf{j}_{15}^0 \dot{\psi}_p \times \mathbf{r}_{1312i}^0) - \mathbf{r}_{87i}^0 \cdot (\mathbf{k}_{16}^0 \dot{\phi}_p \times \mathbf{r}_{1312i}^0) \end{aligned}$$

Aplicando el concepto de relación cíclica para el producto mixto, obtenemos:

$$\dot{x}_{32i} (\mathbf{r}_{87i}^0 \cdot \mathbf{i}_{2i}^0) = \mathbf{r}_{87i}^0 \cdot \mathbf{v}_p^0 - \mathbf{i}_0^0 \dot{\theta}_p \cdot (\mathbf{r}_{1312i}^0 \times \mathbf{r}_{87i}^0) - \mathbf{j}_{15}^0 \dot{\psi}_p \cdot (\mathbf{r}_{1312i}^0 \times \mathbf{r}_{87i}^0) - \mathbf{k}_{16}^0 \dot{\phi}_p \cdot (\mathbf{r}_{1312i}^0 \times \mathbf{r}_{87i}^0)$$

Finalmente:

$$\dot{x}_{32i} (\mathbf{r}_{87i}^0 \cdot \mathbf{i}_{2i}^0) = \mathbf{r}_{87i}^0 \cdot \mathbf{v}_p^0 - \mathbf{i}_0^0 \dot{\theta}_p \cdot \mathbf{u}_i - \mathbf{j}_{15}^0 \dot{\psi}_p \cdot \mathbf{u}_i - \mathbf{k}_{16}^0 \dot{\phi}_p \cdot \mathbf{u}_i \quad (\text{E.5})$$

Donde:

$$\mathbf{u}_i = \mathbf{r}_{1312i}^0 \times \mathbf{r}_{87i}^0 \quad (\text{E.6})$$

Escribiendo la ec. (E.6) seis veces, una para cada $i=1,2,3,4,5,6$, obtenemos seis ecuaciones escalares, las cuales se pueden ordenar de la siguiente forma:

$$\mathbf{J}_q \dot{\mathbf{q}} = \mathbf{J}_R \dot{\mathbf{R}}$$

Siendo \mathbf{J}_q y \mathbf{J}_R las matrices Jacobianas de cinemática directa e inversa, respectivamente, además:

$$\dot{\mathbf{q}} = [\mathbf{v}_p^0 \quad \dot{\theta}_p \quad \dot{\psi}_p \quad \dot{\phi}_p]^T$$

$$\dot{\mathbf{R}} = [\dot{x}_{321} \quad \dot{x}_{322} \quad \dot{x}_{323} \quad \dot{x}_{324} \quad \dot{x}_{325} \quad \dot{x}_{326}]^T$$

Finalmente, de forma matricial se tiene:

$$J_q \dot{\mathbf{q}} = \begin{bmatrix} r_{871}^0 & -i_0^0 \cdot \mathbf{u}_1 & -j_{15}^0 \cdot \mathbf{u}_1 & -k_{16}^0 \cdot \mathbf{u}_1 \\ r_{872}^0 & -i_0^0 \cdot \mathbf{u}_2 & -j_{15}^0 \cdot \mathbf{u}_2 & -k_{16}^0 \cdot \mathbf{u}_2 \\ r_{873}^0 & -i_0^0 \cdot \mathbf{u}_3 & -j_{15}^0 \cdot \mathbf{u}_3 & -k_{16}^0 \cdot \mathbf{u}_3 \\ r_{874}^0 & -i_0^0 \cdot \mathbf{u}_4 & -j_{15}^0 \cdot \mathbf{u}_4 & -k_{16}^0 \cdot \mathbf{u}_4 \\ r_{875}^0 & -i_0^0 \cdot \mathbf{u}_5 & -j_{15}^0 \cdot \mathbf{u}_5 & -k_{16}^0 \cdot \mathbf{u}_5 \\ r_{876}^0 & -i_0^0 \cdot \mathbf{u}_6 & -j_{15}^0 \cdot \mathbf{u}_6 & -k_{16}^0 \cdot \mathbf{u}_6 \end{bmatrix} \begin{bmatrix} v_p^0 \\ \dot{\theta}_p \\ \dot{\psi}_p \\ \dot{\phi}_p \end{bmatrix}$$

$$J_q \dot{\mathbf{q}} = \begin{bmatrix} r_{871}^0 \cdot i_{21}^0 & 0 & 0 & 0 & 0 & 0 \\ 0 & r_{872}^0 \cdot i_{22}^0 & 0 & 0 & 0 & 0 \\ 0 & 0 & r_{873}^0 \cdot i_{23}^0 & 0 & 0 & 0 \\ 0 & 0 & 0 & r_{874}^0 \cdot i_{24}^0 & 0 & 0 \\ 0 & 0 & 0 & 0 & r_{875}^0 \cdot i_{25}^0 & 0 \\ 0 & 0 & 0 & 0 & 0 & r_{876}^0 \cdot i_{26}^0 \end{bmatrix} \begin{bmatrix} \dot{x}_{321} \\ \dot{x}_{322} \\ \dot{x}_{323} \\ \dot{x}_{324} \\ \dot{x}_{325} \\ \dot{x}_{326} \end{bmatrix}$$