



UNIVERSIDAD NACIONAL AUTÓNOMA DE MÉXICO
PROGRAMA DE MAESTRÍA Y DOCTORADO EN INGENIERÍA
MAESTRÍA EN INGENIERÍA – INGENIERÍA MECÁNICA

ANÁLISIS DINÁMICO DEL ROBOT PARALELO HEXA

TESIS
QUE PARA OPTAR POR EL GRADO DE:
MAESTRO EN INGENIERÍA

PRESENTA:
JESÚS VÁZQUEZ HERNÁNDEZ

TUTOR
FRANCISCO CUENCA JIMÉNEZ, FACULTAD DE INGENIERÍA

MÉXICO, D. F. 2013

JURADO ASIGNADO:

Presidente: Dr. Carrera Bolaños Jorge
Secretario: Dr. Rocha Cózatl Edmundo Gabriel
Vocal: Dr. Cuenca Jiménez Francisco
1^{er.} Suplente: M.I. Flores Díaz Ociel
2^{do.} Suplente: M.I. Silva Rico José Antonio

Lugar o lugares donde se realizó la tesis: MÉXICO D.F. CIUDAD UNIVERSITARA

TUTOR DE TESIS:

FRANCISCO CUENCA JIMÉNEZ

FIRMA

Contenido

1. Generalidades	1
1.1. Introducción	1
1.2. Objetivos.....	1
1.2.1. Objetivo General.....	1
1.2.2. Objetivos Particulares.....	1
1.3. Justificación	1
1.4. Metodología	2
1.5. Marco Teórico y Estado del Arte	2
1.6. Arquitectura del Robot.....	3
2. Análisis Cinemático	5
2.1. Introducción	5
2.2. Grados de Libertad	5
2.3. Solución Algebraica	6
2.4. Cálculo de Posición	6
2.4.1. Solución del Ángulo θ_{4i}	10
2.4.2. Solución del Ángulo θ_{8i}	13
2.4.3. Solución del Ángulo θ_{9i}	15
2.4.4. Solución del Ángulo θ_{11i}	16
2.4.5. Solución del Ángulo θ_{13i}	17
2.4.6. Solución del Ángulo θ_{12i}	19
2.5. Cálculo de Velocidad	20
2.5.1. Velocidad del Ángulo θ_{4i}	20
2.5.2. Velocidad del Ángulo θ_{8i}	22
2.5.3. Velocidad del Ángulo θ_{9i}	23
2.5.4. Velocidad del Ángulo θ_{11i}	24

2.5.5. Velocidad del Ángulo θ_{13i}	25
2.5.6. Velocidad del Ángulo θ_{12i}	26
2.6. Cálculo de Aceleración	28
2.6.1. Aceleración del Ángulo θ_{4i}	28
2.6.2. Aceleración del Ángulo θ_{8i}	30
2.6.3. Aceleración del Ángulo θ_{9i}	31
2.6.4. Aceleración del Ángulo θ_{11i}	32
2.6.5. Aceleración del Ángulo θ_{13i}	33
2.6.6. Aceleración del Ángulo θ_{12i}	34
2.7. Análisis de Singularidades	35
2.7.1. Análisis Vectorial de Posición Lineal.....	35
2.7.2. Análisis Vectorial de Velocidad Lineal	37
2.7.3. Análisis Vectorial de Velocidad Angular	38
2.7.4. Matriz Jacobiana de Velocidad para θ_{4i}	38
2.7.5. Matriz Jacobiana de Velocidad para θ_{9i}	40
3. Formulación Newton-Euler.....	43
3.1. Introducción	43
3.2. Dinámica del Robot Hexa	44
3.2.1. Análisis del Cuerpo 1_i	44
3.2.2. Análisis del Cuerpo 2_i	48
3.2.3. Análisis del Cuerpo 3_i	52
3.2.4. Análisis del Plato Móvil y Carga	56
3.2.5. Solución del Método Newton-Euler	62
4. Formulación Euler-Lagrange	67
4.1. Introducción	67
4.2. Velocidad de Centros de Gravedad y Velocidad Angular	68
4.2.1. Velocidad de Centro de Gravedad del Cuerpo 1_i	69
4.2.2. Velocidad Angular del Cuerpo 1_i	69
4.2.3. Velocidad de Centro de Gravedad del Cuerpo 2_i	70
4.2.4. Velocidad Angular del Cuerpo 2_i	71

4.2.5. Velocidad de Centro de Gravedad del Cuerpo 3i	72
4.2.6. Velocidad Angular del Cuerpo 3i	73
4.2.7. Velocidad de Centro de Gravedad del Plato Móvil	74
4.2.8. Velocidad Angular del Plato Móvil	75
4.2.9. Velocidad de Centro de Gravedad de la Carga.....	76
4.2.10. Velocidad angular de la carga.....	76
4.3. Función Lagrangiana.....	77
4.3.1. Desarrollo del Primer Término de la Ecuación de Lagrange.....	77
4.3.2. Desarrollo del Segundo Término de la Ecuación de Lagrange	92
4.3.3. Fuerzas Generalizadas	117
4.3.4. Sustitución de los términos en la Ecuación de Lagrange	120
4.3.5. Solución del método Euler-Lagrange.....	122
5. Resultados	125
6. Conclusiones	131
Bibliografía	133
Apéndice A	135
Apéndice B	137
Apéndice C	143
Apéndice D	153
Apéndice E	183
Apéndice F.....	187
Apéndice G	193

Nomenclatura

GDL – Grados de libertad.

$c\theta$ – $\text{Cos } \theta$.

$s\theta$ – $\text{Sen } \theta$.

\mathbf{r}_a^b – Vector de posición del cuerpo a proyectado en la base b .

$\mathbf{T}_{z1}(x)$ – Matriz de traslación en el eje x .

$\mathbf{T}_{z2}(y)$ – Matriz de traslación en el eje y .

$\mathbf{T}_{z3}(z)$ – Matriz de traslación en el eje z .

$\mathbf{T}_{z4}(\theta_x)$ – Matriz de rotación en el eje x .

$\mathbf{T}_{z5}(\theta_y)$ – Matriz de rotación en el eje y .

$\mathbf{T}_{z6}(\theta_z)$ – Matriz de rotación en el eje z .

\mathbf{T}_{xy} – Matriz de transformación de la base x a la base y .

\mathbf{R}_m^n – Matriz de transformación que proyecta de la base m a la n .

\mathbf{Q}_m^n – Matriz de transformación de torsores que proyecta de la base m a la n .

$\boldsymbol{\omega}_i^j$ – Velocidad angular del cuerpo i proyectada en la base j .

$\boldsymbol{\alpha}_i^j$ – Aceleración angular del cuerpo i proyectada en la base j .

\mathbf{F}_{Gj} – Fuerza debida a la aceleración del centro de gravedad del cuerpo j .

\mathbf{M}_{Oj} – Momento debido a las fuerzas inerciales medido en el origen de la base j .

\mathbf{W}_j – Torsor que representa el peso del cuerpo j .

$\mathbf{r}_i^j, \mathbf{v}_i^j, \mathbf{a}_i^j, \mathbf{R}_i^j, \mathbf{V}_i^j, \mathbf{A}_i^j$ – Vectores de posición, velocidad y aceleración de nombre i proyectados en la base j .

$\mathbf{F}_i^A, \mathbf{F}_i^R, \mathbf{F}_i^I$ – Torsores de fuerzas aplicadas (A), reactivas (R) e inerciales (I) del cuerpo i .

\mathbf{I}_{ij} – Matriz de inercia del cuerpo i cadena j .

K – Energía cinética del sistema mecánico.

L – Función lagrangiana.

$\mathbf{M}_{i,j}$ – Matriz de elementos de masa del cuerpo i , cadena j .

q_j – Coordenada j -ésima generalizada.

\mathbf{q} – Vector de coordenadas generalizadas.

U – Energía potencial del sistema mecánico.

\mathbf{Q}_j – Vector de fuerzas generalizadas.

Capítulo 1

Generalidades

1.1. Introducción

En este capítulo se presentan los objetivos del proyecto de tesis, justificación de los temas a desarrollar, estado del arte, así como la metodología empleada. Los temas desarrollados en este trabajo de tesis son: Análisis Cinemático Inverso, Análisis del Jacobiano, Análisis Dinámico Newton-Euler y Análisis Dinámico Euler-Lagrange.

1.2. Objetivos

1.2.1. Objetivo General

Obtener un modelo dinámico del Robot *Hexa* que permita, en un estudio posterior, implementar un algoritmo de control con alguno de los esquemas de control más usados, así como un modelo dinámico que permita diseñar cada uno de los elementos mecánicos del robot.

1.2.2. Objetivos Particulares

1. Realizar el análisis cinemático. Esta parte del trabajo implica hacer la cinemática inversa y hacer un análisis de singularidades de cinemática directa e inversa del robot.
2. Realizar el análisis dinámico. Se requieren usar los métodos de Newton-Euler y Euler-Lagrange para posteriormente; con base en los resultados del primero, hacer la selección de los materiales y actuadores necesarios; y obtener la ecuación general de control para Implementar el algoritmo de control con ayuda del segundo.

1.3. Justificación

Existen varias formulaciones para el análisis dinámico de robots paralelos como son; Newton, Trabajo Virtual y Lagrange. Aunque los dos primeros resultan ser relativamente sencillos, estos no resultan en un modelo dinámico adecuado para la mayoría de los esquemas de control; tales como: robusto, adaptativo y robusto-adaptativo. Dicho modelo es comúnmente obtenido con la formulación de Lagrange.

Debido a la complejidad y a las cadenas cinemáticas cerradas de los robots paralelos, el análisis dinámico inverso, usando la formulación de Lagrange, resulta complicado y es por eso que algunos investigadores han realizado algunas simplificaciones, de manera que se han obtenido modelos más simplificados que permiten un análisis más sencillo pero que no es una solución generalizada.

Los modelos simplificados dejan que el algoritmo de control compense los errores en el modelo dinámico.

Por otro lado, si se genera un modelo dinámico completo (robusto), el algoritmo de control podría ser mucho más sencillo, además, se sabe que entre más variables tome en cuenta el modelo matemático, tendrá más probabilidades de éxito el algoritmo de control. Por tales motivos, en el análisis dinámico presentado en este trabajo de tesis se intento tomar el mayor número de variables y se desprecian algunas de estas, tales como: fuerzas de fricción entre los elementos y las inercias de los motores. Y aun de esta forma, el modelo presentado en esta tesis incluye más variables de las que se han usado en otros trabajos. (Inverse Dynamics of Hexa Parallel Robot Using Lagrangian Dynamics Formulation, 2008), (Dynamic Modeling of Parallel Robots for Computed-Torque Control Implementation, 1998).

1.4. Metodología

1. Análisis Cinemático
 - a) Análisis de Posición
 - b) Análisis de Velocidad
 - c) Análisis de aceleración
 - d) Análisis de singularidades
2. Análisis Dinámico
 - a) Formulación Newton-Euler
 - b) Formulación Euler-Lagrange
 - b.1) Energía Cinética
 - b.2) Energía Potencial
 - b.3) Función Lagrangiana
 - c) Simulación por software

1.5. Marco Teórico y Estado del Arte

Los robots manipuladores aparecieron primero como sistemas mecánicos constituidos por una estructura que constaba de barras muy robustas acopladas por juntas rotacionales o prismáticas, dichas estructuras son la concatenación de barras, formando estas una cadena cinemática abierta (Robot Serial). Debido a la naturaleza del acoplamiento de estos manipuladores, aun pensando que tienen barras bastante robustas, su capacidad de carga y su rigidez son muy pequeñas cuando se comparan las mismas propiedades con máquinas multiaxiales. Obviamente, una baja rigidez implica una baja precisión en la posición. Con el fin de remediar dichos inconvenientes, los robots paralelos han sido propuestos para resistir cargas más grandes con barras ligeras.

En los robots paralelos se puede distinguir una plataforma fija, una plataforma móvil y varios brazos. Cada brazo es a su vez una cadena cinemática de tipo serial donde las dos últimas barras son las dos plataformas. Contrario a los robots seriales, donde todas sus juntas son actuadas; los robots paralelos tienen juntas no actuadas, lo cual genera una importante diferencia entre los dos tipos. La presencia de juntas no actuadas, en general, hace más complejo el análisis de los robots paralelos que el de los seriales (Angeles, 1997).

Una de las metodologías existentes para el análisis dinámico de manipuladores es la formulación *Newton-Euler*. Dicha formulación incorpora todas las fuerzas actuando sobre los eslabones. Por lo tanto, las ecuaciones dinámicas resultantes incluyen; las fuerzas de restricción

entre dos eslabones adyacentes; las fuerzas activas, como son el peso y los torques debidos a los actuadores y las fuerzas inerciales. Las fuerzas de restricción son útiles para el dimensionamiento de eslabones y selección de elementos mecánicos, tales como: rodamientos, pernos, tornillos, etc; durante la etapa de diseño. El método consiste en el cálculo adelantado de las velocidades y aceleraciones de cada eslabón, seguido por el cálculo reiterativo de las fuerzas y momentos de cada junta. Para el desarrollo de este análisis se emplean matrices de rotación básicas que nos permiten representar la rotación de un cuerpo en el espacio. Ya que la rotación es un giro en el espacio de tres grados de libertad, un conjunto de tres parámetros independientes son suficientes para describir la orientación de un cuerpo en el espacio. (Tsai, 1999)

Por otro lado, en la metodología de *Euler-Lagrange*, se desea determinar los torques aplicados por los actuadores en los eslabones de entrada, para que el efector final alcance una trayectoria dada. A diferencia del método antes mencionado, este no contiene en sus ecuaciones todas las fuerzas de restricción entre eslabones, obteniéndose así ecuaciones de una forma cerrada. Este método, en otras palabras, formula ecuaciones de movimiento usando un conjunto de coordenadas generalizadas (Spong, y otros, 1989). Esto permite eliminar todas o algunas de las fuerzas de restricción y permite manejar desplazamientos lineales como angulares con un solo tipo de coordenadas. Con el entendimiento de la dinámica del manipulador, es posible diseñar un controlador con mejores características de ejecución que con aquellos encontrados usando métodos heurísticos, después de que ha sido construido el manipulador. A las dos metodologías mencionadas anteriormente, algunos investigadores (Tsai, 1999), han realizado algunas simplificaciones, de manera que se han obtenido modelos más simplificados que permiten un análisis más sencillo pero que no es una solución generalizada.

Los robots paralelos pueden ser encontrados en diferentes aplicaciones tales como; simuladores de vuelo (Stewart, 1965), entramados articulados ajustables (Reinholtz, y otros), maquinas de fresado (Arai, y otros, 1991), equipos punteadores (Gosselin, y otros, 1994), máquinas caminantes (Waldron, y otros, 1984), tomar y colocar (Clavel, 1988). Actualmente han sido desarrollados como centros de maquinado de alta velocidad y alta precisión (Giddings, 1995). El robot Hexa, el cual es presentado por primera vez por Pierrot (Pierrot, y otros, 1991) es un robot de 6 GDL el cual se derivó del robot Delta, este último diseñado por Raymond Clavel y usado para operaciones de tomar y colocar de alta velocidad. La idea del robot Delta se basa en las propiedades de los paralelogramos; en un paralelogramo la orientación de la barra de salida permanece fija respecto a la barra de entrada. Tres paralelogramos restringen la orientación de la plataforma móvil a solo tres GDL de traslación.

1.6. Arquitectura del Robot

El robot Hexa presenta ciertas ventajas respecto a los robots seriales y al mismo robot Delta, como son: alta precisión, baja inercia, alta velocidad y altas capacidades de carga (Angeles, 1997). Esto se debe a que la carga se divide entre sus seis cadenas cinemáticas, las cuales suelen ser muy ligeras y constan de un brazo superior y un brazo inferior unidos por una junta universal. La base del robot se encuentra fija a la estructura de soporte y los seis motores se encuentran fijos a esta. El hecho de que los actuadores se encuentren fijos y que las cadenas sean ligeras permite al robot alcanzar altas aceleraciones. Los motores se encuentran unidos a un brazo y lo accionan directamente. Cada una de las cadenas cinemáticas se encuentra unida a la base y al plato móvil por medio de una junta rotacional y una universal respectivamente. Cada una de las cadenas del robot tiene una junta activa en la junta rotacional y dos pasivas en las juntas esférica y universal (Figura 1.1). El robot hexa ha sido utilizado en varias aplicaciones tales como experimentos en

equipos aeroespaciales así como en instrumentos médicos de perforado y corte de huesos. Gracias a la orientación y traslación de su efector final, puede ser utilizado en un sinfín de aplicaciones más.

Debido a que las seis cadenas cinemáticas son idénticas, solo será descrita a detalle una de ellas. Todos los eslabones, la base y el plato móvil son considerados cuerpos rígidos.



Figura 1.1 Robot Paralelo Hexa

Capítulo 2

Análisis Cinemático

2.1. Introducción

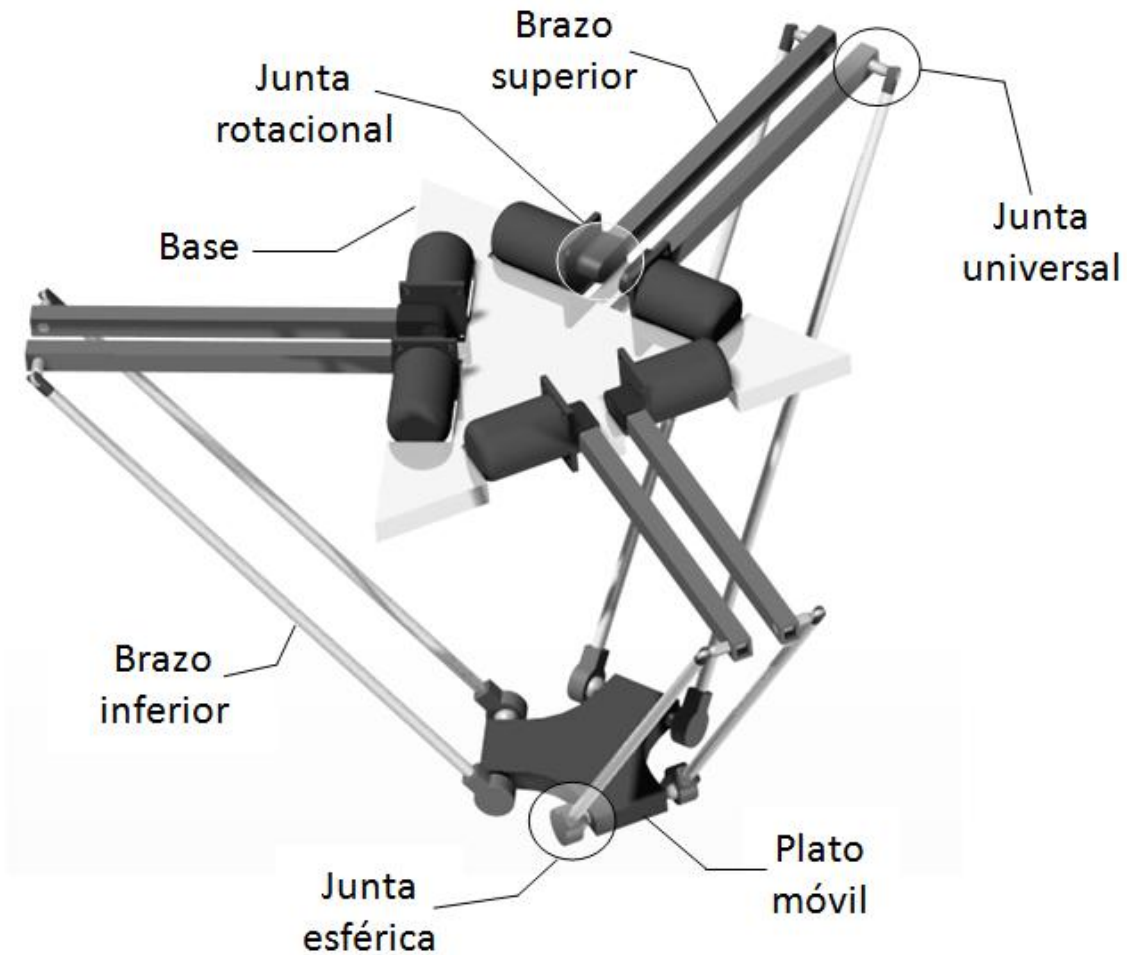
La cinemática es la parte de la mecánica que estudia las leyes del movimiento de los cuerpos sin tener en cuenta los efectos externos, fuerzas y/o torques que lo causan, limitándose, esencialmente, al estudio de la trayectoria en función del tiempo, es decir; trata la posición, velocidad y aceleración de los cuerpos.

Sistemas de referencia son empleados para definir la cinemática inversa de un cuerpo. En la descripción del presente trabajo de investigación se emplean dos sistemas de referencia cartesianos, sistemas de referencia fijos o marcos inerciales y sistemas de referencia relativos o marcos locales. En el presente capítulo se desarrolla el análisis de posición, velocidad y aceleración de los ángulos encontrados en las juntas del robot.

2.2. Grados de Libertad

Los grados de libertad de un mecanismo son el número de parámetros independientes o entradas necesarias para especificar la configuración de un mecanismo completamente. Los grados de libertad de un mecanismo paralelo pueden ser determinados con la aplicación de la fórmula de Chebyshev-Grübler-Kutzbach.

$$L = 6(b - g - 1) + \sum_k f_k$$

Donde b y g son respectivamente, número de cuerpos (incluyendo la base), número de juntas del mecanismo y f_k el número de grados de libertad de la junta k . Por lo tanto, para la plataforma se tiene:

$$\begin{aligned} b &= 14 \\ g &= 18 \\ \sum_k f_k &= 36 \end{aligned}$$

Sustituyendo los valores se tiene:

$$L = 6(14 - 18 - 1) + 36 \quad \Rightarrow \quad \boxed{L = 6}$$

Por lo tanto el manipulador en estudio tiene 6 grados de libertad.

2.3. Solución Algebraica

En esta sección se obtendrán de forma cerrada las variables actuadas y no actuadas. En una ecuación de forma cerrada se expresan las variables incógnitas como una función de las variables de entrada conocidas, en este caso particular; las variables incógnitas son las posiciones, velocidades y aceleraciones angulares en cada una de las juntas que conforman el manipulador; y las variables de entrada conocidas son las que definen la posición y orientación del efector final en el espacio. De esta manera se tendrá un sistema de ecuaciones escalares de $n \times n$ de donde se despejarán cada una de las variables incógnitas.

2.4. Cálculo de Posición

En el problema cinemático inverso de la posición, se tiene que, dada la posición $(x_p, y_p, z_p, \psi, \theta, \phi)$ del plato móvil, hallar la posición de los ángulos $\theta_{4i}, \theta_{8i}, \theta_{9i}, \theta_{11i}, \theta_{12i}, \theta_{13i}$ que se encuentran en las juntas del robot. Dicho análisis es esencial para el control de posición de robots paralelos.

Para hacer el análisis de posición del robot Hexa se tomaron como herramienta las matrices de transformación homogéneas, las cuales nos proporcionan desplazamiento y rotación de un cuerpo en el espacio. La matriz de transformación homogénea (Stejskal, y otros, 1996) es una matriz de 4×4 que tiene la siguiente definición:

$$T = \begin{bmatrix} R & d \\ 0 & 1 \end{bmatrix} \quad (2.1)$$

Donde:

R = Matriz de Rotación

d = Vector de Desplazamiento

0 = Vector cero

La matriz R de 3×3 denota la orientación de una base móvil respecto a una base de referencia, el vector d de 3×1 denota la posición del origen de la base móvil relativa a la base de referencia, el vector 0 de 1×3 denota el vector cero. Las matrices de transformación de traslación en los ejes x , y y z respectivamente son:

$$T_{z1}(x) = \begin{bmatrix} 1 & 0 & 0 & x \\ 0 & 1 & 0 & 0 \\ 0 & 0 & 1 & 0 \\ 0 & 0 & 0 & 1 \end{bmatrix} \quad T_{z2}(y) = \begin{bmatrix} 1 & 0 & 0 & 0 \\ 0 & 1 & 0 & y \\ 0 & 0 & 1 & 0 \\ 0 & 0 & 0 & 1 \end{bmatrix} \quad T_{z3}(z) = \begin{bmatrix} 1 & 0 & 0 & 0 \\ 0 & 1 & 0 & 0 \\ 0 & 0 & 1 & z \\ 0 & 0 & 0 & 1 \end{bmatrix}$$

Las matrices de transformación de rotación en los ejes x , y y z respectivamente son:

$$T_{z4}(\theta_x) = \begin{bmatrix} 1 & 0 & 0 & 0 \\ 0 & c\theta_x & -s\theta_x & 0 \\ 0 & s\theta_x & c\theta_x & 0 \\ 0 & 0 & 0 & 1 \end{bmatrix} \quad T_{z5}(\theta_y) = \begin{bmatrix} c\theta_y & 0 & s\theta_y & 0 \\ 0 & 1 & 0 & 0 \\ -s\theta_y & 0 & c\theta_y & 0 \\ 0 & 0 & 0 & 1 \end{bmatrix} \quad T_{z6}(\theta_z) = \begin{bmatrix} c\theta_z & -s\theta_z & 0 & 0 \\ s\theta_z & c\theta_z & 0 & 0 \\ 0 & 0 & 1 & 0 \\ 0 & 0 & 0 & 1 \end{bmatrix}$$

Debido a la simetría entre las cadenas cinemáticas, se describirá a detalle sólo una de las seis que conforman el robot, y se podrán diferenciar con ayuda del iterador i , como se muestra en la Figura 1.1.



Figura 2.1. Sistemas de referencia del inercial al 7i

En las figuras 2.1, 2.2, 2.3, 2.4 y 2.5 se muestra la secuencia en la cual se fueron generando, a partir de la base inercial (i_0, j_0, k_0) las bases locales. Aplicando una matriz de transformación de giro en el eje z , una transformación de traslación en el eje x y nuevamente una transformación de giro en el eje z ; se forman respectivamente las bases 1i, 2i y 3i, es decir:

$$T_{03i} = T_{z6}(\delta_{1i}) T_{z1}(x_{2i}) T_{z6}(\delta_{3i})$$

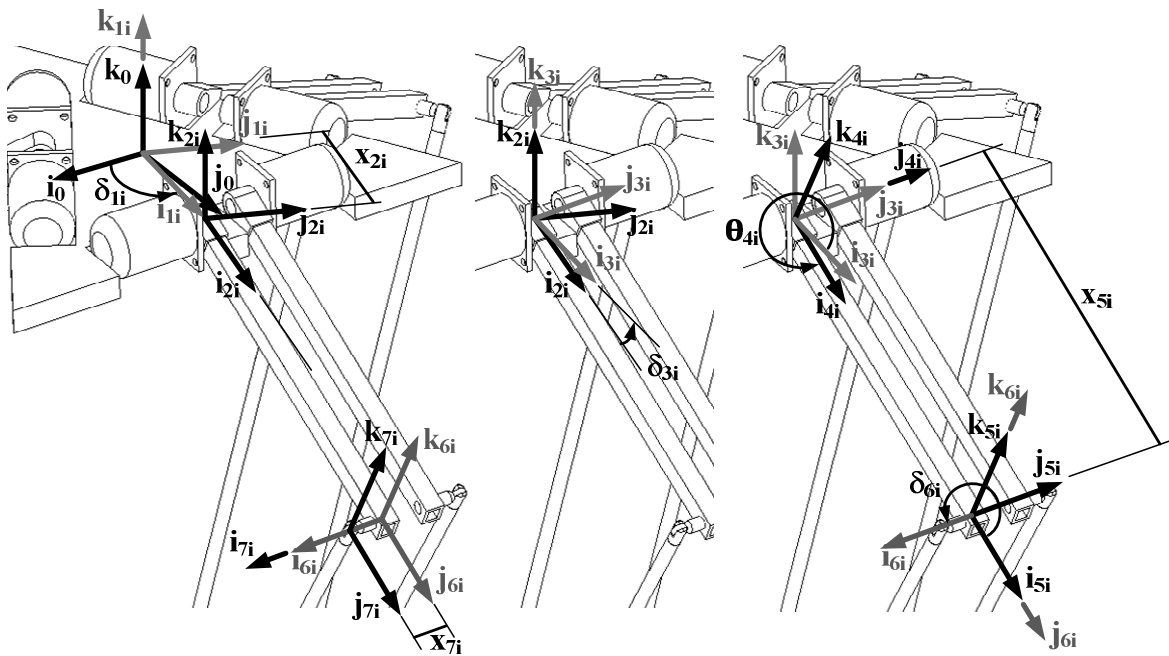

Figura 2.2. Sistemas de referencia del 7i al 10i



Figura 2.3. Sistemas de referencia del 10i al 13i

Para generar la base 4i a partir de la base 3i se requiere aplicar una transformación de rotación en el eje y , esto es:

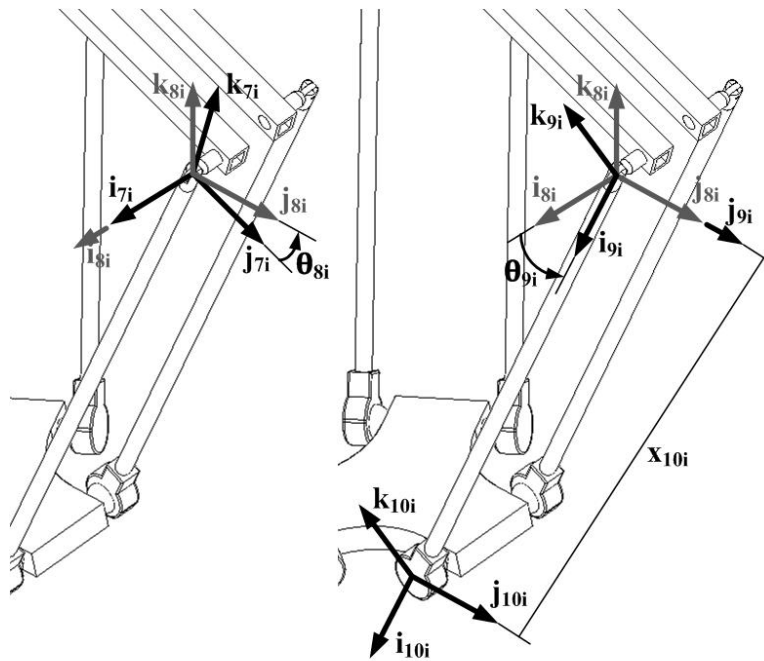
$$T_{34i} = T_{z5}(\theta_{4i})$$

De la misma forma, para obtener las 5i, 6i y 7i, se tiene:

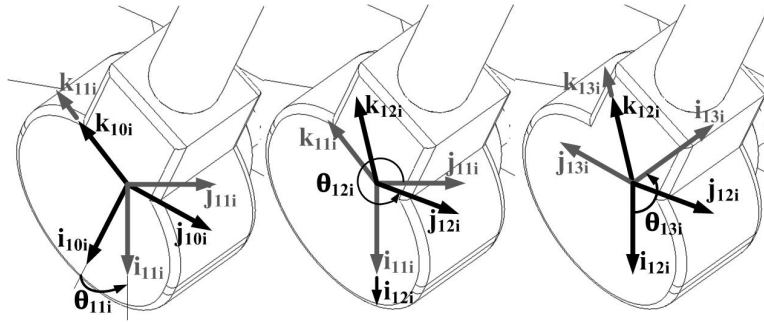
$$T_{47i} = T_{z1}(x_{5i})T_{z6}(\delta_{6i})T_{z1}(x_{7i})$$

En la Figura 2.2 se muestra como se generaron las bases 8i, 9i y 10i, las transformaciones empleadas son:

$$T_{79i} = T_{z4}(\theta_{8i})T_{z5}(\theta_{9i})$$

$$T_{910i} = T_{z1}(x_{10i})$$



Figura 2.4. Sistemas de referencia del 13i al 17i

Para las bases 11i, 12i, y 13i que se encuentran en la junta esférica (Figura 2.3), se tiene:

$$T_{1013i} = T_{z6}(\theta_{11i})T_{z4}(\theta_{12i})T_{z6}(\theta_{13i})$$

Para las bases 14i, 15i, 16i y 17i que se encuentran en el plato móvil (Figura 2.4), se tiene:

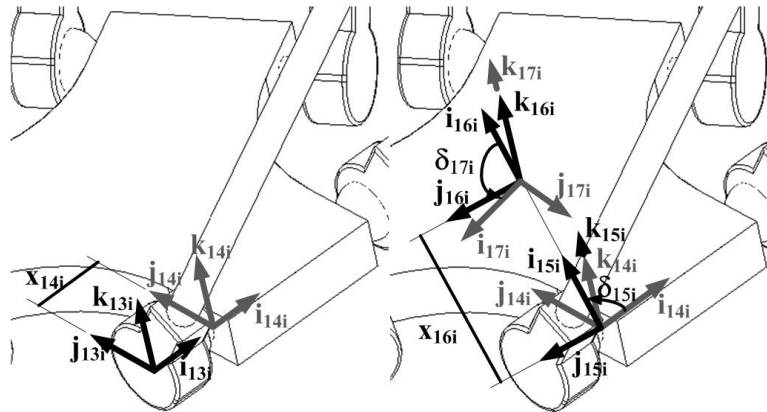
$$T_{1317i} = T_{z1}(x_{14i})T_{z6}(\delta_{15i})T_{z1}(x_{16i})T_{z6}(\delta_{17i})$$



Figura 2.5. Ángulos de Euler

Por último, para generar una ecuación de lazo se requiere generar las bases que nos permitan llegar de la base inercial a la base 17i sin pasar por los brazos del robot, esto es, tomando como datos la posición y orientación deseados del efector final. En la Figura 2.5 se muestran las bases generadas para la orientación del plato y las transformaciones requeridas son las siguientes:

$$T_{0p} = T_{z1}(x) T_{z2}(y) T_{z3}(z) T_{z6}(\psi) T_{z4}(\theta) T_{z6}(\phi)$$

En la Figura 2.5 no se muestran las bases para las traslaciones x, y, z ; ya que son paralelas a la inercial. Solo se muestran las bases para la orientación. Por otro lado, los ángulos δ_{ni} y las distancias x_{ni} son constantes y dependen de la estructura del robot. De esta manera, podemos observar que las incógnitas a determinar son los ángulos de las juntas que nos permiten orientar el robot Hexa en el espacio, siendo estos:

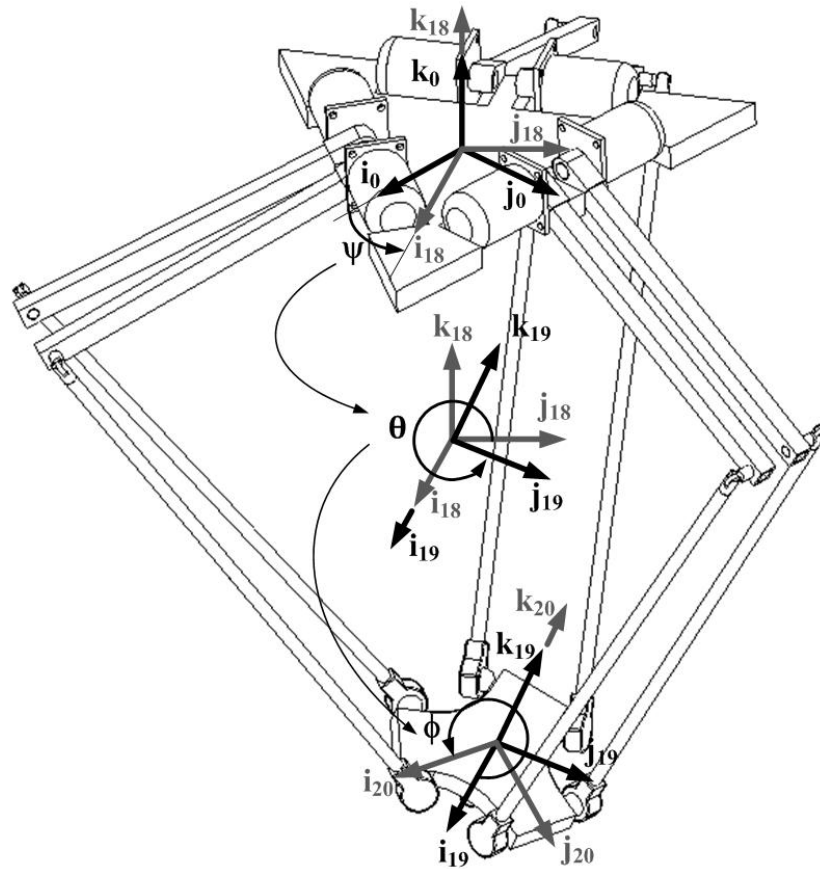
$$\theta_{4i}, \theta_{8i}, \theta_{9i}, \theta_{11i}, \theta_{12i}, \theta_{13i} \quad \text{donde } i=1, 2, 3, 4, 5, 6.$$

Con lo que se tiene un total de 36 variables a calcular, de las cuales, por los grados de libertad, 6 son actuadas. Se definen a θ_{4i} como las variables actuadas del mecanismo, ya que se encuentran pegadas a la base y se busca que esta última soporte el peso de los actuadores.



Figura 2.6 Ecuación de lazo vectorial

2.4.1. Solución del Ángulo θ_{4i}

Para la obtención de dicho ángulo se requiere obtener una ecuación escalar que se encuentre sólo en función de los desplazamientos y ángulos conocidos (propios de la estructura del mecanismo), así como del mismo ángulo θ_{4i} . Por tal motivo se tuvo que emplear la construcción de lazos vectoriales, tal como se muestra en la Figura 2.6. En el proceso se busca eliminar las tres incógnitas de la junta esférica, esto se consigue haciendo la construcción vectorial como sigue, se hace notar que los siguientes vectores están definidos en la base inercial:

$$\mathbf{r}_{1i}^0 + \mathbf{r}_{4i}^0 + \mathbf{r}_{6i}^0 + \mathbf{r}_{9i}^0 = \mathbf{r}_p^0 + \mathbf{r}_{15i}^0 + \mathbf{r}_{13i}^0 \quad (2.2)$$

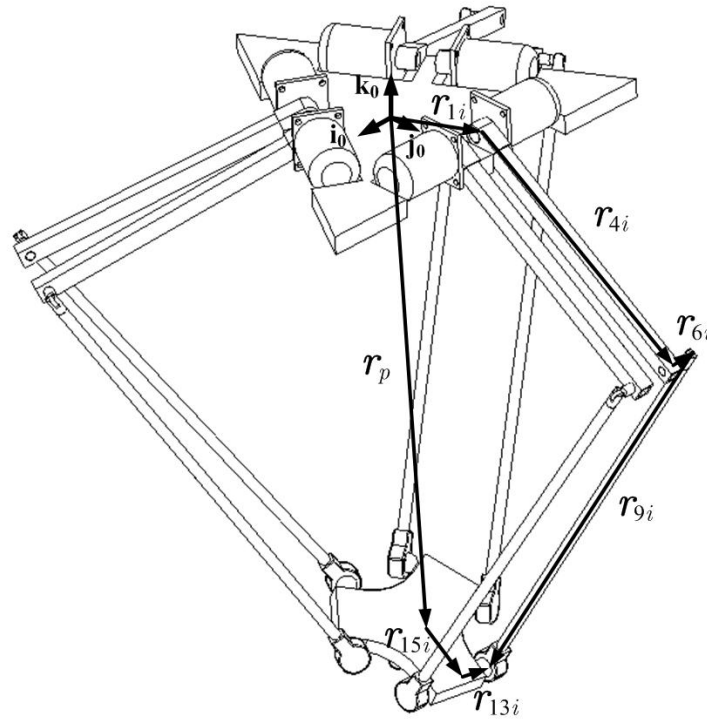
Sabemos que, a excepción de \mathbf{r}_p^0 , cada uno de los vectores tiene magnitud constante debida a la geometría del prototipo, entonces, podemos calcular su magnitud, para eso despejamos \mathbf{r}_{9i} de la ecuación anterior tal como sigue:

$$\mathbf{r}_{9i}^0 = \mathbf{r}_p^0 + \mathbf{r}_{15i}^0 + \mathbf{r}_{13i}^0 - (\mathbf{r}_{1i}^0 + \mathbf{r}_{4i}^0 + \mathbf{r}_{6i}^0) \quad (2.3)$$

Ahora, si escribimos la ec. (2.3) utilizando las transformaciones homogéneas se tiene que:

$$\mathbf{r}_{9i}^0 = \mathbf{N} = \mathbf{T}_{0p} \mathbf{T}_{1713i} \mathbf{n} - (\mathbf{T}_{03i} \mathbf{T}_{34i} \mathbf{T}_{47i} \mathbf{n}) \quad (2.4)$$

Donde:

$$\mathbf{n} = [0, 0, 0, 1]^T \quad (2.5)$$

$$\mathbf{T}_{1713i} = \mathbf{T}_{1317i}^{-1}$$

Nótese que se postmultiplica por \mathbf{n} para obtener la última columna de la matriz de transformación. Al calcular la magnitud de \mathbf{r}_{9i} se consiguen eliminar ahora las dos incógnitas de la junta universal:

$$\|\mathbf{r}_{9i}^0\| = \left\| \left(\mathbf{T}_{0p} \mathbf{T}_{1713i} - \mathbf{T}_{03i} \mathbf{T}_{34i} \mathbf{T}_{47i} \right) \mathbf{n} \right\| = \|\mathbf{N}\| \quad (2.6)$$

Donde, por restricción geométrica, sabemos también que $x_{10i} = \|\mathbf{r}_{9i}\|$, sustituyendo:

$$x_{10i} = \left\| \left(\mathbf{T}_{0p} \mathbf{T}_{1713i} - \mathbf{T}_{03i} \mathbf{T}_{34i} \mathbf{T}_{47i} \right) \mathbf{n} \right\| = \|\mathbf{N}\| \quad (2.7)$$

Simplificando:

$$(x_{10i})^2 = \mathbf{N}^T \mathbf{N}$$

Agrupando y simplificando $\mathbf{N}^T \mathbf{N}$ para $c\theta_{4i}$ y $s\theta_{4i}$ se obtiene una ecuación de la forma:

$$\begin{aligned} A_{1i} c\theta_{4i} + B_{1i} s\theta_{4i} + D_{1i} &= (x_{9i})^2 \\ A_{1i} c\theta_{4i} + B_{1i} s\theta_{4i} + (D_{1i} - (x_{9i})^2) &= 0 \end{aligned}$$

Renombrando:

$$A_{1i} c\theta_{4i} + B_{1i} s\theta_{4i} + C_{1i} = 0 \quad (2.8)$$

Donde:

$$\begin{aligned} A_{1i} &= (x_{5i} + x_{7i} c\delta_{6i}) (2x_{2i} c\delta_{3i} - 2x_p c(\delta_{1i} + \delta_{3i})) + 2(x_{16i} c(\delta_{17i} - \phi) + \\ &\quad x_{14i} c(\delta_{15i} + \delta_{17i} - \phi)) c(\delta_{1i} + \delta_{3i} - \psi) - 2y_p s(\delta_{1i} + \delta_{3i}) - \\ &\quad 2c\theta(x_{16i} s(\delta_{17i} - \phi) + x_{14i} s(\delta_{15i} + \delta_{17i} - \phi)) s(\delta_{1i} + \delta_{3i} - \psi)) \\ B_{1i} &= 2(x_{5i} + x_{7i} c\delta_{6i}) (z_p + s\theta(x_{16i} s(\delta_{17i} - \phi) + x_{14i} s(\delta_{15i} + \delta_{17i} - \phi))) \\ C_{1i} &= -x_{10i}^2 + x_p^2 + y_p^2 + z_p^2 + (x_{5i} + x_{7i} c\delta_{6i})^2 + (2(x_{14i}^2 + x_{16i}^2 + x_{2i}^2) + x_{7i}^2 + \\ &\quad 4x_{14i} x_{16i} c\delta_{15i} - 4x_{2i} x_p c\delta_{1i} - x_{7i}^2 c(2\delta_{6i}) - 4(x_p - x_{2i} c\delta_{1i})(x_{16i} c(\delta_{17i} - \phi) + \\ &\quad x_{14i} c(\delta_{15i} + \delta_{17i} - \phi)) c\psi - 4x_{2i} y_p s\delta_{1i} + 4z_p s\theta(x_{16i} s(\delta_{17i} - \phi) + \\ &\quad x_{14i} s(\delta_{15i} + \delta_{17i} - \phi)) - 4x_{7i} s\delta_{6i} (y_p c(\delta_{1i} + \delta_{3i}) + x_{2i} s\delta_{3i} - x_p s(\delta_{1i} + \delta_{3i})) + \\ &\quad (x_{16i} c(\delta_{17i} - \phi) + x_{14i} c(\delta_{15i} + \delta_{17i} - \phi)) s(\delta_{1i} + \delta_{3i} - \psi) - 4(x_{16i} c(\delta_{17i} - \phi) + \\ &\quad x_{14i} c(\delta_{15i} + \delta_{17i} - \phi)) (y_p - x_{2i} s\delta_{1i}) s\psi - 4c\theta(x_{16i} s(\delta_{17i} - \phi) + \\ &\quad x_{14i} s(\delta_{15i} + \delta_{17i} - \phi)) (- (y_p c\psi) + x_{7i} c(\delta_{1i} + \delta_{3i} - \psi) s\delta_{6i} + x_{2i} s(\delta_{1i} - \psi) + x_p s\psi)) / 2 \end{aligned} \quad (2.9)$$

La solución de la ecuación (2.8) se muestra a continuación:

$$\theta_{4i} = 2 \arctan \left(\frac{B_{1i} \pm \sqrt{A_{1i}^2 + B_{1i}^2 - C_{1i}^2}}{A_{1i} - C_{1i}} \right) \quad (2.10)$$

El desarrollo de la solución de la ecuación (2.8) se muestra en el apéndice A. A continuación se muestran las características geométricas del Robot Hexa en cuestión. Estos datos se presentan de esta forma debido a que se repiten para cada una de las cadenas cinemáticas.

$$\begin{aligned} x_{2i} &= 0.093 \text{ m} & x_{10i} &= 0.530 \text{ m} \\ x_{5i} &= 0.300 \text{ m} & x_{14i} &= 0.020 \text{ m} & \text{donde } i &= 1, 2, 3, 4, 5, 6. \\ x_{7i} &= 0.030 \text{ m} & x_{16i} &= 0.0725 \text{ m} \end{aligned}$$

Además se tiene para cada cadena cinemática:

$$\begin{array}{lll}
 \delta_{11} = 77.5^\circ & \delta_{12} = 102.5^\circ & \delta_{13} = 197.5^\circ \\
 \delta_{31} = 12^\circ & \delta_{32} = 348^\circ & \delta_{33} = 12^\circ \\
 \delta_{61} = 270^\circ & \delta_{62} = 90^\circ & \delta_{63} = 270^\circ \\
 \delta_{151} = 66^\circ & \delta_{152} = 294^\circ & \delta_{153} = 66^\circ \\
 \delta_{171} = 114^\circ & \delta_{172} = 66^\circ & \delta_{173} = 354^\circ \\
 \\
 \delta_{14} = 222.5^\circ & \delta_{15} = 317.5^\circ & \delta_{16} = 342.5^\circ \\
 \delta_{34} = 348^\circ & \delta_{35} = 12^\circ & \delta_{36} = 348^\circ \\
 \delta_{64} = 90^\circ & \delta_{65} = 270^\circ & \delta_{66} = 90^\circ \\
 \delta_{154} = 294^\circ & \delta_{155} = 66^\circ & \delta_{156} = 294^\circ \\
 \delta_{174} = 306^\circ & \delta_{175} = 234^\circ & \delta_{176} = 186^\circ
 \end{array}$$



Figura 2.7 Gráfica de θ_{4i}

La trayectoria en línea recta descrita en el apéndice B, es empleada para el robot Hexa, teniendo un tiempo de recorrido de:

$$t_f = 5 \text{ s}$$

Los puntos, inicial y final de la trayectoria, son:

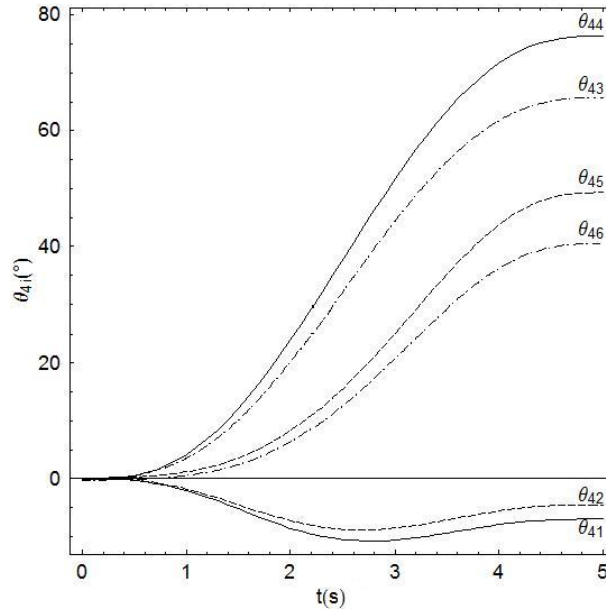
$$\mathbf{p}_i = [0, 0, -0.419]^T \quad \mathbf{p}_f = [0.2, 0.3, -0.5]^T$$

Y las orientaciones, inicial y final, son:

$$\boldsymbol{\beta}_i = [0^\circ, 0^\circ, 0^\circ]^T \quad \boldsymbol{\beta}_f = [10^\circ, 30^\circ, 10^\circ]^T$$

En la Figura 2.7 se muestra la gráfica que describe el comportamiento de los ángulos θ_{4i} del robot Hexa, al recorrer la trayectoria descrita en el apéndice B en un tiempo de 5 segundos.

Como se puede ver en Figura 2.7, las gráficas de los 6 ángulos comienzan desde cero, por lo que se tomará esta posición del robot, como posición inicial (Home) de cada una de las trayectorias a realizar.

2.4.2. Solución del Ángulo θ_{8i}

De la misma manera en que se encontró el ángulo θ_{4i} , se generará una ecuación de lazo para calcular los ángulos θ_{8i} y θ_{9i} que corresponden a la junta universal del robot Hexa, tal como sigue (Figura 2.6):

$$\mathbf{r}_{1i}^0 + \mathbf{r}_{4i}^0 + \mathbf{r}_{6i}^0 + \mathbf{r}_{9i}^0 - \mathbf{r}_{15i}^0 - \mathbf{r}_{13i}^0 = \mathbf{r}_p^0 \quad (2.11)$$

La siguiente ec. matricial nos lleva al centro del plato móvil. El miembro izquierdo de la ec. representa los movimientos a través de las cadenas cinemáticas y el miembro derecho representa el movimiento a través del plato móvil. Es decir:

$$\mathbf{T}_{03i} \mathbf{T}_{34i} \mathbf{T}_{47i} \mathbf{T}_{79i} \mathbf{T}_{910i} \mathbf{T}_{1013i} \mathbf{T}_{1317i} = \mathbf{T}_{0p} \quad (2.12)$$

En la ec. (2.12) las siguientes transformaciones son conocidas:

$$\mathbf{T}_{03i}, \mathbf{T}_{34i}, \mathbf{T}_{47i}, \mathbf{T}_{1317i}$$

Ya que además de contener distancias x_i y ángulos δ_i constantes, también contienen un ángulo variable θ_{4i} que se calculó en la sección anterior. Por lo tanto, para poder calcular los ángulos de la junta universal, despejamos, dejando del lado izquierdo las transformaciones $\mathbf{T}_{79i}, \mathbf{T}_{910i}, \mathbf{T}_{1013i}$:

$$\mathbf{T}_{79i} \mathbf{T}_{910i} \mathbf{T}_{1013i} = \mathbf{T}_{47i}^{-1} \mathbf{T}_{34i}^{-1} \mathbf{T}_{03i}^{-1} \mathbf{T}_{0p} \mathbf{T}_{1713i}^{-1} \quad (2.13)$$

Renombrando el lado derecho de la ec. (2.13) se tiene:

$$\mathbf{T}_{79i} \mathbf{T}_{910i} \mathbf{T}_{1013i} = \mathbf{T}_{total} \quad (2.14)$$

Donde:

$$\mathbf{T}_{total} = \begin{bmatrix} a_{11i} & a_{12i} & a_{13i} & a_{14i} \\ a_{21i} & a_{22i} & a_{23i} & a_{24i} \\ a_{31i} & a_{32i} & a_{33i} & a_{34i} \\ 0 & 0 & 0 & 1 \end{bmatrix} \quad (2.15)$$

La transformación \mathbf{T}_{1013i} contiene solo los ángulos de la junta esférica, dichos ángulos se encuentran dentro de la matriz de rotación, que a su vez, se encuentra en la transformación resultante del lado izquierdo de la ec. (2.14). Entonces, para eliminar las incógnitas de la junta esférica y obtener el vector de desplazamientos se multiplica por el vector \mathbf{n} que se muestra en las ecuaciones (2.5).

$$\mathbf{T}_{79i} \mathbf{T}_{910i} \mathbf{T}_{1013i} \mathbf{n} = \mathbf{T}_{total} \mathbf{n} \quad (2.16)$$

Esto es:

$$\begin{bmatrix} x_{10i} c\theta_{9i} \\ x_{10i} s\theta_{8i} s\theta_{9i} \\ -x_{10i} c\theta_{8i} s\theta_{9i} \\ 1 \end{bmatrix} = \begin{bmatrix} a_{14i} \\ a_{24i} \\ a_{34i} \\ 1 \end{bmatrix} \quad (2.17)$$

Para resolver el ángulo θ_{8i} se toman las componentes 2 y 3 de cada lado de la ecuación. Posteriormente se despejan $s\theta_{8i}$ y $c\theta_{8i}$ y empleando la función tangente se obtiene:

$$\tan \theta_{8i} = \frac{s\theta_{8i}}{c\theta_{8i}} = \frac{a_{24i}}{-a_{34i}} \quad (2.18)$$

Despejando θ_{8i} :

$$\theta_{8i} = \arctan\left(\frac{a_{24i}}{-a_{34i}}\right) \quad (2.19)$$

Donde:

$$\begin{aligned} a_{24i} = & x_{2i} c\delta_{6i} s\delta_{3i} + x_{5i} s\delta_{6i} + x_{2i} c\delta_{3i} c\theta_{4i} s\delta_{6i} - x_p (c\delta_{6i} s(\delta_{1i} + \delta_{3i}) + \\ & c(\delta_{1i} + \delta_{3i}) c\theta_{4i} s\delta_{6i}) + y_p (c(\delta_{1i} + \delta_{3i}) c\delta_{6i} - c\theta_{4i} s(\delta_{1i} + \delta_{3i}) s\delta_{6i}) + \\ & z_p s\delta_{6i} s\theta_{4i} + (- (x_{16i} c\delta_{17i}) - x_{14i} c(\delta_{15i} + \delta_{17i})) \\ & (- (c\theta_{4i} c\phi c(\delta_{1i} + \delta_{3i} - \psi) s\delta_{6i}) + c\delta_{6i} c\theta c(\delta_{1i} + \delta_{3i} - \psi) s\phi + \\ & s\delta_{6i} s\theta s\theta_{4i} s\phi - (c\delta_{6i} c\phi + c\theta c\theta_{4i} s\delta_{6i} s\phi) s(\delta_{1i} + \delta_{3i} - \psi)) + \\ & (x_{16i} s\delta_{17i} + x_{14i} s(\delta_{15i} + \delta_{17i})) (c\phi s\delta_{6i} s\theta s\theta_{4i} + (c\delta_{6i} s(\delta_{1i} + \delta_{3i}) + \\ & c(\delta_{1i} + \delta_{3i}) c\theta_{4i} s\delta_{6i}) (c\psi s\phi + c\theta c\phi s\psi)) + (c(\delta_{1i} + \delta_{3i}) c\delta_{6i} - \\ & c\theta_{4i}) s(\delta_{1i} + \delta_{3i}) s\delta_{6i} (c\theta c\phi c\psi - s\phi s\psi) \\ a_{34i} = & z_p c\theta_{4i} - x_{2i} c\delta_{3i} s\theta_{4i} + x_p c(\delta_{1i} + \delta_{3i}) s\theta_{4i} + y_p s(\delta_{1i} + \delta_{3i}) s\theta_{4i} + \\ & (x_{16i} s\delta_{17i} + x_{14i} s(\delta_{15i} + \delta_{17i})) (c\theta_{4i} c\phi s\theta + s\theta_{4i} (- (c(\delta_{1i} + \delta_{3i} - \psi) s\phi) + \\ & c\theta c\phi s(\delta_{1i} + \delta_{3i} - \psi))) + (- (x_{16i} c\delta_{17i}) - x_{14i} c(\delta_{15i} + \delta_{17i})) (c\theta_{4i} s\theta s\phi + \\ & s(\delta_{1i} + \delta_{3i}) s\theta_{4i} (c\theta c\psi s\phi + c\phi s\psi)) + c(\delta_{1i} + \delta_{3i}) s\theta_{4i} (c\phi c\psi - c\theta s\phi s\psi) \end{aligned} \quad (2.20)$$

En la Figura 2.8 se muestra la gráfica que describe el comportamiento de los ángulos θ_{8i} del robot Hexa, al recorrer la trayectoria descrita en el apéndice B en un tiempo de 5 segundos.



Figura 2.8 Gráfica de θ_{8i}

2.4.3. Solución del Ángulo θ_{9i}

Para el cálculo de este ángulo se partirá de la ec. (2.17), donde en este caso, la única incógnita es θ_{9i} , ya que θ_{8i} se calculó en la sección anterior. Para resolver el ángulo θ_{9i} se toman las componentes 1 y 3 de cada lado de la ecuación. Posteriormente se despejan $s\theta_{9i}$ y $c\theta_{9i}$ y empleando la función tangente se obtiene:

$$\tan \theta_{9i} = \frac{s\theta_{9i}}{c\theta_{9i}} = \frac{-a_{34i}}{a_{14i}c\theta_{8i}} \quad (2.21)$$

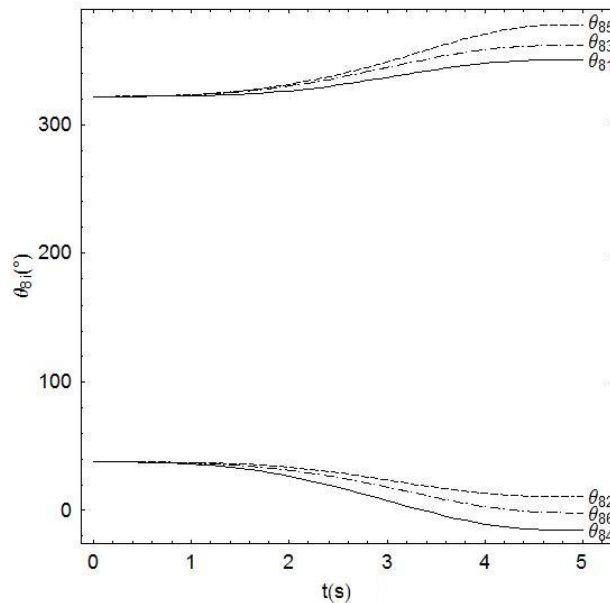
Despejando θ_{9i} :

$$\theta_{9i} = \arctan\left(\frac{-a_{34i}}{a_{14i}c\theta_{8i}}\right) \quad (2.22)$$

Donde a_{34i} se encuentra en las ecuaciones (2.20) y a_{14i} es:

$$\begin{aligned} a_{14i} = & -x_{7i} - x_{5i}c\delta_{6i} - x_{2i}c\delta_{3i}c\delta_{6i}c\theta_{4i} + x_{2i}s\delta_{3i}s\delta_{6i} + \\ & y_p(c\delta_{6i}c\theta_{4i}s(\delta_{1i} + \delta_{3i}) + c(\delta_{1i} + \delta_{3i})s\delta_{6i}) + x_p(c(\delta_{1i} + \delta_{3i})c\delta_{6i}c\theta_{4i} - \\ & s(\delta_{1i} + \delta_{3i})s\delta_{6i}) - z_p c\delta_{6i}s\theta_{4i} + (x_{16i}s\delta_{17i} + x_{14i}s(\delta_{15i} + \delta_{17i})) \\ & (- (c\delta_{6i}(c\phi s\theta s\theta_{4i} + c\theta_{4i}c(\delta_{1i} + \delta_{3i} - \psi)s\phi - c\theta c\theta_{4i}c\phi s(\delta_{1i} + \delta_{3i} - \psi))) + \\ & s(\delta_{1i} + \delta_{3i})s\delta_{6i}(c\psi s\phi + c\theta c\phi s\psi) + c(\delta_{1i} + \delta_{3i})s\delta_{6i}(c\theta c\phi c\psi - s\phi s\psi)) + \\ & (- (x_{16i}c\delta_{17i}) - x_{14i}c(\delta_{15i} + \delta_{17i}))(- (c\delta_{6i}s\theta s\theta_{4i}s\phi) + (c\delta_{6i}c\theta_{4i}s(\delta_{1i} + \delta_{3i}) + \\ & c(\delta_{1i} + \delta_{3i})s\delta_{6i})(c\theta c\psi s\phi + c\phi s\psi) + (c(\delta_{1i} + \delta_{3i})c\delta_{6i}c\theta_{4i} - \\ & s(\delta_{1i} + \delta_{3i})s\delta_{6i})(c\phi c\psi - c\theta s\phi s\psi)) \end{aligned} \quad (2.23)$$

En la Figura 2.9 se muestra la gráfica que describe el comportamiento de los ángulos θ_{9i} del robot Hexa, al recorrer la trayectoria descrita en el apéndice B en un tiempo de 5 segundos.



Figura 2.9 Gráfica de θ_{9i}

2.4.4. Solución del Ángulo θ_{11i}

Los ángulos θ_{11i} , θ_{12i} y θ_{13i} conforman las juntas esféricas del robot Hexa. Dichos ángulos se obtienen mediante una formulación de lazos matriciales, es decir, por medio de giros y desplazamientos definidos por transformaciones homogéneas, se generan lazos que partan del sistema de referencia inercial o absoluto y terminen en un sistema relativo deseado.

Para el cálculo de θ_{11i} se partirá de la ec. matricial (2.12):

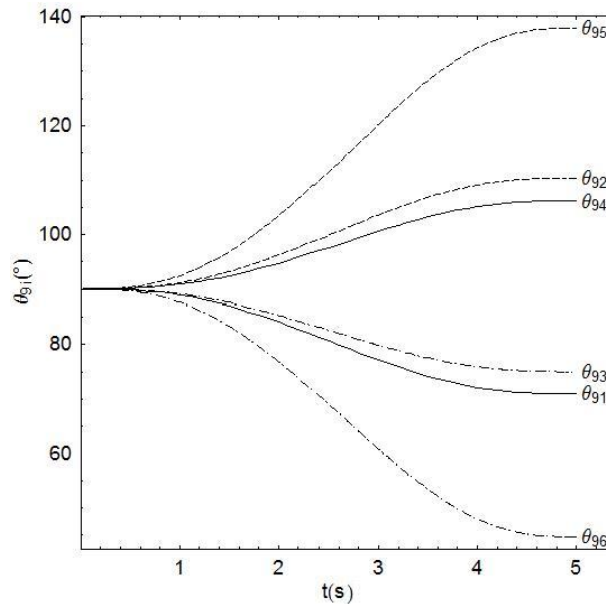
$$\mathbf{T}_{03i} \mathbf{T}_{34i} \mathbf{T}_{47i} \mathbf{T}_{79i} \mathbf{T}_{910i} \mathbf{T}_{1013i} \mathbf{T}_{1317i} = \mathbf{T}_{0p}$$

Donde las transformaciones \mathbf{T}_{03i} , \mathbf{T}_{34i} , \mathbf{T}_{47i} , \mathbf{T}_{79i} , \mathbf{T}_{910i} , \mathbf{T}_{1317i} son conocidas. Ya que además de contener distancias x_i y ángulos δ_i constantes, también contienen los ángulos variables θ_{4i} , θ_{8i} y θ_{9i} que se calcularon en las secciones anteriores. Por lo tanto, para poder calcular los ángulos de la junta esférica, despejamos, dejando del lado izquierdo la transformación \mathbf{T}_{1013i} , que contiene los ángulos θ_{11i} , θ_{12i} y θ_{13i} .

$$\mathbf{T}_{1013i} = \mathbf{T}_{910i}^{-1} \mathbf{T}_{79i}^{-1} \mathbf{T}_{47i}^{-1} \mathbf{T}_{34i}^{-1} \mathbf{T}_{03i}^{-1} \mathbf{T}_{0p} \mathbf{T}_{1317i}^{-1} \quad (2.24)$$

Renombrando el lado derecho de la ec. (2.24) se tiene:

$$\mathbf{T}_{1013i} = \mathbf{T}_{ci} \quad (2.25)$$

Donde:

$$\mathbf{T}_{1013i} = \begin{bmatrix} c\theta_{11i}c\theta_{13i} - c\theta_{12i}s\theta_{11i}s\theta_{13i} & -c\theta_{12i}c\theta_{13i}s\theta_{11i} - c\theta_{11i}s\theta_{13i} & s\theta_{11i}s\theta_{12i} & 0 \\ c\theta_{13i}s\theta_{11i} - c\theta_{11i}c\theta_{12i}s\theta_{13i} & c\theta_{11i}c\theta_{12i}c\theta_{13i} - s\theta_{11i}s\theta_{13i} & -c\theta_{11i}s\theta_{12i} & 0 \\ s\theta_{12i}s\theta_{13i} & c\theta_{13i}s\theta_{12i} & c\theta_{12i} & 0 \\ 0 & 0 & 0 & 1 \end{bmatrix} \quad (2.26)$$

$$\mathbf{T}_{ci} = \begin{bmatrix} c_{11i} & c_{12i} & c_{13i} & c_{14i} \\ c_{21i} & c_{22i} & c_{23i} & c_{24i} \\ c_{31i} & c_{32i} & c_{33i} & c_{34i} \\ 0 & 0 & 0 & 1 \end{bmatrix} \quad (2.27)$$

Para resolver el ángulo θ_{11i} se toman las componentes (1,3) y (2,3) de cada lado de la ecuación. Posteriormente se despejan $s\theta_{11i}$ y $c\theta_{11i}$ y empleando la función tangente se obtiene:

$$\tan \theta_{11i} = \frac{s\theta_{11i}}{c\theta_{11i}} = \frac{c_{13i}}{-c_{23i}} \quad (2.28)$$

Despejando θ_{11i} :

$$\theta_{11i} = \arctan \left(\frac{c_{13i}}{-c_{23i}} \right) \quad (2.29)$$

Donde:

$$\begin{aligned}
c_{13i} &= c\theta(- (c\theta_{4i}c\theta_{8i}s\theta_{9i}) - s\theta_{4i}(c\delta_{6i}c\theta_{9i} - s\delta_{6i}s\theta_{8i}s\theta_{9i})) - c\psi s\theta((c\delta_{1i}c\delta_{3i} - \\
&\quad s\delta_{1i}s\delta_{3i})(c\theta_{9i}s\delta_{6i} + c\delta_{6i}s\theta_{8i}s\theta_{9i}) + (c\delta_{3i}s\delta_{1i} + c\delta_{1i}s\delta_{3i})(- (c\theta_{8i}s\theta_{4i}s\theta_{9i}) + \\
&\quad c\theta_{4i}(c\delta_{6i}c\theta_{9i} - s\delta_{6i}s\theta_{8i}s\theta_{9i}))) + s\theta((- (c\delta_{3i}s\delta_{1i} - c\delta_{1i}s\delta_{3i})(c\theta_{9i}s\delta_{6i} + \\
&\quad c\delta_{6i}s\theta_{8i}s\theta_{9i}) + (c\delta_{1i}c\delta_{3i} - s\delta_{1i}s\delta_{3i})(- (c\theta_{8i}s\theta_{4i}s\theta_{9i}) + c\theta_{4i}(c\delta_{6i}c\theta_{9i} - s\delta_{6i}s\theta_{8i}s\theta_{9i})))s\psi \quad (2.30) \\
c_{23i} &= c\theta(c\theta_{8i}s\delta_{6i}s\theta_{4i} + c\theta_{4i}s\theta_{8i}) - c\psi s\theta(c\delta_{6i}c\theta_{8i}(c\delta_{1i}c\delta_{3i} - s\delta_{1i}s\delta_{3i}) + \\
&\quad (c\delta_{3i}s\delta_{1i} + c\delta_{1i}s\delta_{3i})(- (c\theta_{4i}c\theta_{8i}s\delta_{6i}) + s\theta_{4i}s\theta_{8i})) + s\theta(c\delta_{6i}c\theta_{8i}(- (c\delta_{3i}s\delta_{1i}) - \\
&\quad c\delta_{1i}s\delta_{3i}) + (c\delta_{1i}c\delta_{3i} - s\delta_{1i}s\delta_{3i})(- (c\theta_{4i}c\theta_{8i}s\delta_{6i}) + s\theta_{4i}s\theta_{8i}))s\psi
\end{aligned}$$

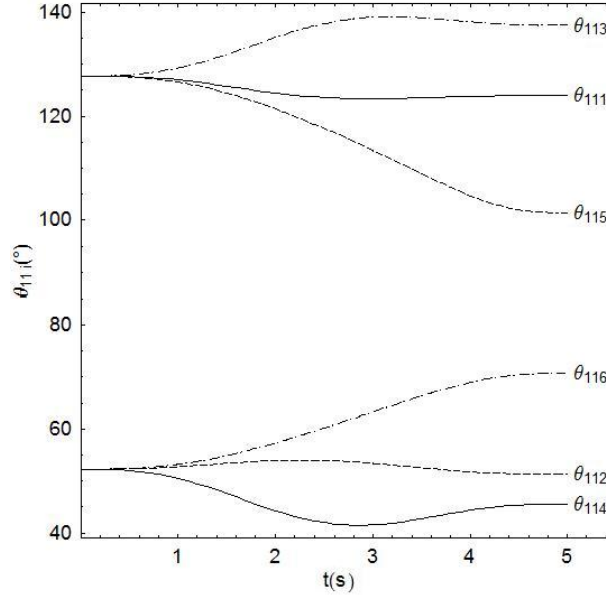
Figura 2.10 Gráfica de θ_{11i}

En la Figura 2.10 se muestra la gráfica que describe el comportamiento de los ángulos θ_{11i} del robot Hexa, al recorrer la trayectoria descrita en el apéndice B en un tiempo de 5 segundos.

2.4.5. Solución del Ángulo θ_{13i}

Para resolver el ángulo θ_{13i} se trabajará a partir de la ecuación (2.25), de donde se toman las componentes (3,1) y (3,2) de cada lado de la ecuación. Posteriormente se despejan $s\theta_{13i}$ y $c\theta_{13i}$ y empleando la función tangente se obtiene:

$$\tan \theta_{13i} = \frac{s\theta_{13i}}{c\theta_{13i}} = \frac{c_{31i}}{c_{32i}} \quad (2.31)$$

Despejando θ_{13i} :

$$\theta_{13i} = \arctan\left(\frac{c_{31i}}{c_{32i}}\right) \quad (2.32)$$

Donde:

$$\begin{aligned}
c_{31i} = & -(s(\delta_{15i} + \delta_{17i}))(c\phi s\theta(c\theta_{4i}c\theta_{8i})c\theta_{9i} - s\theta_{4i}(c\theta_{9i}s\delta_{6i}s\theta_{8i} + c\delta_{6i}s\theta_{9i})) + (s\delta_{1i} + \delta_{3i} \\
& (c\delta_{6i}c\theta_{9i}s\theta_{8i} - s\delta_{6i}s\theta_{9i}) + c(\delta_{1i} + \delta_{3i})(c\theta_{8i}c\theta_{9i}s\theta_{4i} + c\theta_{4i}(c\theta_{9i}s\delta_{6i}s\theta_{8i} + \\
& c\delta_{6i}s\theta_{9i})))(-c\psi s\phi) - c\theta c\phi s\psi + (c(\delta_{1i} + \delta_{3i})(-c\delta_{6i}c\theta_{9i}s\theta_{8i}) + s\delta_{6i}s\theta_{9i}) + \\
& s(\delta_{1i} + \delta_{3i})(c\theta_{8i}c\theta_{9i}s\theta_{4i} + c\theta_{4i}(c\theta_{9i}s\delta_{6i}s\theta_{8i} + c\delta_{6i}s\theta_{9i}))) (c\theta c\phi c\psi - \\
& s\phi s\psi)) + c(\delta_{15i} + \delta_{17i})(s\theta(c\theta_{4i}c\theta_{8i}c\theta_{9i} - s\theta_{4i}(c\theta_{9i}s\delta_{6i}s\theta_{8i} + c\delta_{6i}s\theta_{9i}))s\phi + \\
& (c(\delta_{1i} + \delta_{3i})(-c\delta_{6i}c\theta_{9i}s\theta_{8i}) + s\delta_{6i}s\theta_{9i}) + s(\delta_{1i} + \delta_{3i})(c\theta_{8i}c\theta_{9i}s\theta_{4i} + c\theta_{4i} \\
& (c\theta_{9i}s\delta_{6i}s\theta_{8i} + c\delta_{6i}s\theta_{9i}))) (c\theta c\psi s\phi + c\phi s\psi)) + (s(\delta_{1i} + \delta_{3i})(c\delta_{6i}c\theta_{9i}s\theta_{8i} - \\
& s\delta_{6i}s\theta_{9i}) + c(\delta_{1i} + \delta_{3i})(c\theta_{8i}c\theta_{9i}s\theta_{4i} + c\theta_{4i}(c\theta_{9i}s\delta_{6i}s\theta_{8i} + c\delta_{6i}s\theta_{9i}))) \\
& (c\phi c\psi - c\theta s\phi s\psi))
\end{aligned} \tag{2.33}$$

$$\begin{aligned}
c_{32i} = & c(\delta_{15i} + \delta_{17i})(c\phi s\theta(c\theta_{4i}c\theta_{8i}c\theta_{9i} - s\theta_{4i}(c\theta_{9i}s\delta_{6i}s\theta_{8i}) + c\delta_{6i}s\theta_{9i})) + (s(\delta_{1i} + \\
& \delta_{3i})(c\delta_{6i}c\theta_{9i}s\theta_{8i} - s\delta_{6i}s\theta_{9i}) + c(\delta_{1i} + \delta_{3i})(c\theta_{8i}c\theta_{9i}s\theta_{4i} + c\theta_{4i}(c\theta_{9i}s\delta_{6i}s\theta_{8i} + \\
& c\delta_{6i}s\theta_{9i})))(-c\psi s\phi) - c\theta c\phi s\psi + (c(\delta_{1i} + \delta_{3i})(-c\delta_{6i}c\theta_{9i}s\theta_{8i}) + s\delta_{6i}s\theta_{9i}) + \\
& s(\delta_{1i} + \delta_{3i})(c\theta_{8i}c\theta_{9i}s\theta_{4i} + c\theta_{4i}(c\theta_{9i}s\delta_{6i}s\theta_{8i} + c\delta_{6i}s\theta_{9i}))) (c\theta c\phi c\psi - s\phi s\psi)) + \\
& s(\delta_{15i} + \delta_{17i})(s\theta(c\theta_{4i}c\theta_{8i}c\theta_{9i} - s\theta_{4i}(c\theta_{9i}s\delta_{6i}s\theta_{8i} + c\delta_{6i}s\theta_{9i}))s\phi + (c(\delta_{1i} + \delta_{3i}) \\
& (-c\delta_{6i}c\theta_{9i}s\theta_{8i}) + s\delta_{6i}s\theta_{9i}) + s(\delta_{1i} + \delta_{3i})(c\theta_{8i}c\theta_{9i}s\theta_{4i} + c\theta_{4i}(c\theta_{9i}s\delta_{6i}s\theta_{8i} + \\
& c\delta_{6i}s\theta_{9i}))) (c\theta c\psi s\phi + c\phi s\psi)) + (s(\delta_{1i} + \delta_{3i})(c\delta_{6i}c\theta_{9i}s\theta_{8i} - s\delta_{6i}s\theta_{9i}) + c(\delta_{1i} + \\
& \delta_{3i})(c\theta_{8i}c\theta_{9i}s\theta_{4i} + c\theta_{4i}(c\theta_{9i}s\delta_{6i}s\theta_{8i} + c\delta_{6i}s\theta_{9i}))) (c\phi c\psi - c\theta s\phi s\psi))
\end{aligned}$$

En la Figura 2.11 se muestra la gráfica que describe el comportamiento de los ángulos θ_{13i} del robot Hexa, al recorrer la trayectoria descrita en el apéndice B en un tiempo de 5 segundos.



Figura 2.11 Gráfica de θ_{13i}

2.4.6. Solución del Ángulo θ_{12i}

Para resolver el ángulo θ_{12i} , se trabajará a partir de la ecuación (2.25), de donde se toman las componentes (2,1) y (3,1) de cada lado de la ecuación y se obtiene el siguiente sistema de ecuaciones:

$$\begin{aligned} c\theta_{13i}s\theta_{11i} + c\theta_{11i}c\theta_{12i}s\theta_{13i} &= c_{21i} \\ s\theta_{12i}s\theta_{13i} &= c_{31i} \end{aligned}$$

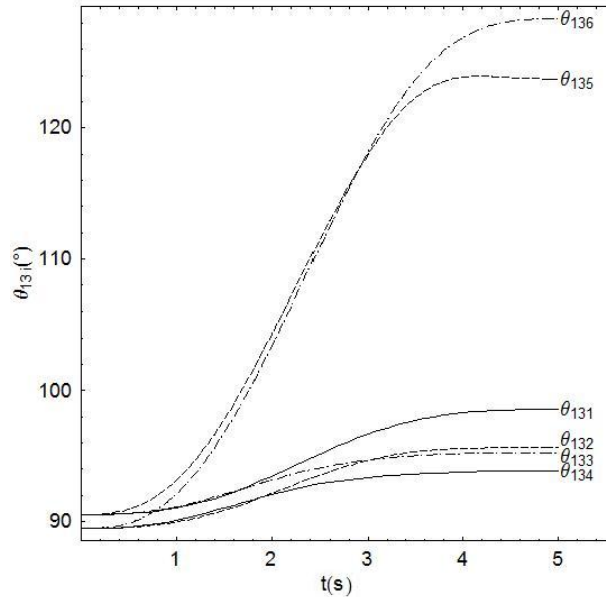
En este caso la única incógnita es θ_{12i} , ya que θ_{11i} y θ_{13i} se calcularon en secciones anteriores. Despejando $s\theta_{12i}$ y $c\theta_{12i}$ y empleando la función tangente se obtiene:

$$\tan \theta_{12i} = \frac{s\theta_{12i}}{c\theta_{12i}} = \frac{c_{31i}c\theta_{11i}}{c_{21i} - c\theta_{13i}s\theta_{11i}} \quad (2.34)$$

Despejando θ_{12i} :

$$\theta_{12i} = \arctan \left(\frac{c_{31i}c\theta_{11i}}{c_{21i} - c\theta_{13i}s\theta_{11i}} \right) \quad (2.35)$$

Donde c_{31i} se encuentra en las ecuaciones (2.33) y c_{21i} es:

$$\begin{aligned} c_{21i} = & -(s\delta_{15i} + \delta_{17i})(c\phi s\theta(c\theta_{8i}s\delta_{6i}s\theta_{4i} + c\theta_{4i}s\theta_{8i})) + (c\delta_{6i}c\theta_{8i}s(\delta_{1i} + \delta_{3i}) + \\ & c(\delta_{1i} + \delta_{3i}))(c\theta_{4i}c\theta_{8i}s\delta_{6i} - s\theta_{4i}s\theta_{8i}))(c\psi s\phi + c\theta c\phi s\psi) + (c(\delta_{1i} + \delta_{3i}) \\ & c\delta_{6i}c\theta_{8i} + s(\delta_{1i} + \delta_{3i})(-c\theta_{4i}c\theta_{8i}s\delta_{6i}) + s\theta_{4i}s\theta_{8i}))(c\theta c\phi c\psi - s\phi s\psi)) + \\ & c(\delta_{15i} + \delta_{17i})(s\theta(c\theta_{8i}s\delta_{6i}s\theta_{4i} + c\theta_{4i}s\theta_{8i}))s\phi + (c\delta_{1i} + \delta_{3i}c\delta_{6i}c\theta_{8i} + s(\delta_{1i} + \\ & \delta_{3i})(-c\theta_{4i}c\theta_{8i}s\delta_{6i}) + s\theta_{4i}s\theta_{8i}))(c\theta c\psi s\phi + c\phi s\psi) + (-c\delta_{6i}c\theta_{8i}s(\delta_{1i} + \\ & \delta_{3i})) + c(\delta_{1i} + \delta_{3i})(-c\theta_{4i}c\theta_{8i}s\delta_{6i}) + s\theta_{4i}s\theta_{8i}))(c\phi c\psi - c\theta s\phi s\psi) \end{aligned} \quad (2.36)$$

En la Figura 2.12 se muestra la gráfica que describe el comportamiento de los ángulos θ_{13i} del robot Hexa, al recorrer la trayectoria descrita en el apéndice B en un tiempo de 5 segundos.



Figura 2.12 Gráfica de θ_{12i}

2.5. Cálculo de Velocidad

En el problema cinemático inverso de la velocidad, se tiene que, dada la velocidad $(\dot{x}_p, \dot{y}_p, \dot{z}_p, \dot{\psi}, \dot{\theta}, \dot{\phi})$ del plato móvil, hallar la velocidad de los ángulos $\dot{\theta}_{4i}, \dot{\theta}_{8i}, \dot{\theta}_{9i}, \dot{\theta}_{11i}, \dot{\theta}_{12i}, \dot{\theta}_{13i}$ que se encuentran en las juntas del robot.

La velocidad de un punto o un cuerpo rígido que experimenta movimiento, puede ser obtenida por la derivada respecto al tiempo de su función de posición. Se asume en esta sección que la posición y orientación de los cuerpos son totalmente conocidas, ya que son resultado del análisis de posición. Por lo tanto, con base en las ecuaciones obtenidas en la sección anterior, se obtendrá la velocidad al derivar con respecto al tiempo cada una de ellas.

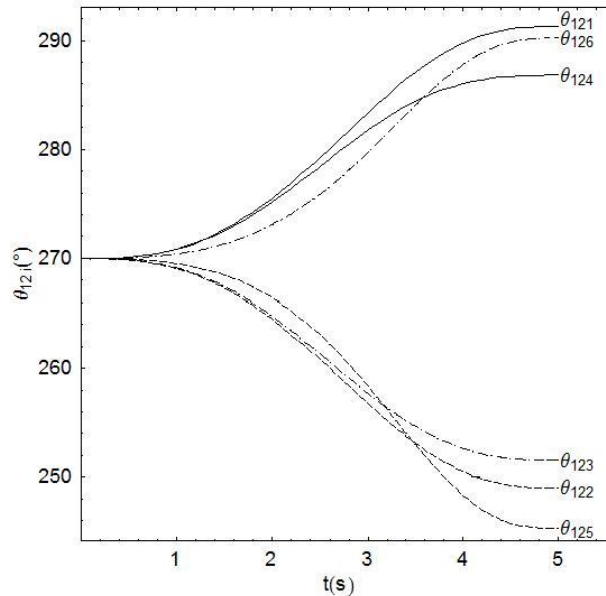
2.5.1. Velocidad del Ángulo θ_{4i}

Tomando la ec. (2.8) y derivando respecto al tiempo obtenemos:

$$\begin{aligned} A_{1i}c\theta_{4i} + B_{1i}s\theta_{4i} + C_{1i} &= 0 \\ \dot{A}_{1i}c\theta_{4i} - A_{1i}s\theta_{4i}\dot{\theta}_{4i} + \dot{B}_{1i}s\theta_{4i} + B_{1i}c\theta_{4i}\dot{\theta}_{4i} + \dot{C}_{1i} &= 0 \end{aligned} \quad (2.37)$$

Despejando $\dot{\theta}_{4i}$ y simplificando se tiene:

$$\dot{\theta}_{4i} = \frac{-(\dot{A}_{1i}c\theta_{4i} + \dot{B}_{1i}s\theta_{4i} + \dot{C}_{1i})}{B_{1i}c\theta_{4i} - A_{1i}s\theta_{4i}} \quad (2.38)$$

Donde A_{1i}, B_{1i}, C_{1i} se encuentran en el análisis de posición, además:

$$\begin{aligned} \dot{A}_{1i} &= 2(x_{5i} + x_{7i}c\delta_{6i})(-\dot{x}_p c(\delta_{1i} + \delta_{3i}) - \dot{y}_p s(\delta_{1i} + \delta_{3i}) + \dot{\theta}s\theta(x_{16i}s(\delta_{17i} - \phi) + x_{14i}s(\delta_{15i} + \delta_{17i} - \phi)) \\ &\quad s(\delta_{1i} + \delta_{3i} - \psi) + \dot{\psi}(c\theta c(\delta_{1i} + \delta_{3i} - \psi)(x_{16i}s(\delta_{17i} - \phi) + x_{14i}s(\delta_{15i} + \delta_{17i} - \phi)) + (x_{16i}c(\delta_{17i} - \phi) + \\ &\quad x_{14i}c(\delta_{15i} + \delta_{17i} - \phi))s(\delta_{1i} + \delta_{3i} - \psi)) + \dot{\phi}(c(\delta_{1i} + \delta_{3i}) - \psi(x_{16i}s(\delta_{17i} - \phi) + x_{14i}s(\delta_{15i} + \delta_{17i} - \\ &\quad \phi)) + c\theta(x_{16i}c(\delta_{17i} - \phi) + x_{14i}c(\delta_{15i} + \delta_{17i} - \phi))s(\delta_{1i} + \delta_{3i} - \psi))) \\ \dot{B}_{1i} &= 2(x_{5i} + x_{7i}c\delta_{6i})(\dot{z}_p - \dot{\phi}(x_{16i}c\delta_{17i} - \phi + x_{14i}c\delta_{15i} + \delta_{17i} - \phi)s\theta + \dot{\theta}c\theta(x_{16i}s\delta_{17i} - \phi + x_{14i}s\delta_{15i} + \\ &\quad \delta_{17i} - \phi)) \\ \dot{C}_{1i} &= 2(\dot{x}_p x_p + \dot{y}_p y_p + \dot{z}_p z_p - \dot{x}_p x_{2i}c\delta_{1i} - \dot{x}_p(x_{16i}c(\delta_{17i} - \phi) + x_{14i}c(\delta_{15i} + \delta_{17i} - \phi))c\psi - \dot{y}_p x_{2i}s\delta_{1i} - \dot{\psi}(x_{16i} \\ &\quad c(\delta_{17i} - \phi) + x_{14i}c(\delta_{15i} + \delta_{17i} - \phi))c\psi(y_p - x_{2i}s\delta_{1i}) - \dot{\phi}z_p(x_{16i}c(\delta_{17i} - \phi) + x_{14i}c(\delta_{15i} + \delta_{17i} - \phi)) \\ &\quad s\theta + \dot{\theta}z_p c\theta(x_{16i}s(\delta_{17i} - \phi) + x_{14i}s(\delta_{15i} + \delta_{17i} - \phi)) - \dot{\phi}(x_p - x_{2i}c\delta_{1i})c\psi(x_{16i}s(\delta_{17i} - \phi) + x_{14i} \\ &\quad s(\delta_{15i} + \delta_{17i} - \phi)) + \dot{z}_p s\theta(x_{16i}s(\delta_{17i} - \phi) + x_{14i}s(\delta_{15i} + \delta_{17i} - \phi)) - x_{7i}s\delta_{6i}(\dot{y}_p c(\delta_{1i} + \delta_{3i}) - \dot{\psi} \\ &\quad (x_{16i}c(\delta_{17i} - \phi) + x_{14i}c(\delta_{15i} + \delta_{17i} - \phi))c(\delta_{1i} + \delta_{3i} - \psi) - \dot{x}_p s(\delta_{1i} + \delta_{3i}) + \dot{\phi}(x_{16i}s(\delta_{17i} - \phi) + x_{14i} \\ &\quad s(\delta_{15i} + \delta_{17i} - \phi))s(\delta_{1i} + \delta_{3i} - \psi)) - \dot{y}_p(x_{16i}c(\delta_{17i} - \phi) + x_{14i}c(\delta_{15i} + \delta_{17i} - \phi))s\psi + \dot{\psi}(x_p - x_{2i} \\ &\quad c\delta_{1i})(x_{16i}c(\delta_{17i} - \phi) + x_{14i}c(\delta_{15i} + \delta_{17i} - \phi))s\psi - \dot{\phi}(y_p - x_{2i}s\delta_{1i})(x_{16i}s(\delta_{17i} - \phi) + x_{14i}s(\delta_{15i} + \\ &\quad \delta_{17i} - \phi))s\psi - \dot{\phi}c\theta(x_{16i}c(\delta_{17i} - \phi) + x_{14i}c(\delta_{15i} + \delta_{17i} - \phi))(y_p c\psi - x_{7i}c(\delta_{1i} + \delta_{3i} - \psi)s\delta_{6i} - x_{2i} \\ &\quad s(\delta_{1i} - \psi) - x_p s\psi) + \dot{\theta}s\theta(x_{16i}s(\delta_{17i} - \phi) + x_{14i}s(\delta_{15i} + \delta_{17i} - \phi))(- (y_p c\psi) + x_{7i}c(\delta_{1i} + \delta_{3i}) - \\ &\quad \psi s\delta_{6i} + x_{2i}s(\delta_{1i} - \psi) + x_p s\psi) - c\theta(x_{16i}s(\delta_{17i} - \phi) + x_{14i}s(\delta_{15i} + \delta_{17i} - \phi))(- (\dot{y}_p c\psi) + \dot{x}_p \\ &\quad s\psi + \dot{\psi}(- (x_{2i}c(\delta_{1i} - \psi)) + x_p c\psi + x_{7i}s\delta_{6i}s(\delta_{1i} + \delta_{3i} - \psi) + y_p s\psi))) \end{aligned} \quad (2.39)$$

Sustituyendo las ecuaciones (2.9) y (2.39) en la ecuación (2.38), para después agrupar en $\dot{x}_p, \dot{y}_p, \dot{z}_p, \dot{\psi}, \dot{\theta}, \dot{\phi}$, se tiene:

$$\dot{\theta}_{4i} = \frac{1}{V_{1i}} (V_{2i}\dot{x}_p + V_{3i}\dot{y}_p + V_{4i}\dot{z}_p + V_{5i}\dot{\psi} + V_{6i}\dot{\theta} + V_{7i}\dot{\phi}) \quad (2.40)$$

Donde los coeficientes son:

$$\begin{aligned} V_{1i} &= B_{1i}c\theta_{4i} - A_{1i}s\theta_{4i} \\ V_{2i} &= 2(-x_p + x_{2i}c\delta_{1i} + c\delta_{1i} + \delta_{3i}(x_{5i} + x_{7i}c\delta_{6i}))c\theta_{4i} + \\ &\quad x_{16i}c(\delta_{17i} - \phi)c\psi + x_{14i}c(\delta_{15i} + \delta_{17i} - \phi)c\psi - x_{7i}s(\delta_{1i} + \\ &\quad \delta_{3i})s\delta_{6i} + c\theta(x_{16i}s(\delta_{17i} - \phi) + x_{14i}s(\delta_{15i} + \delta_{17i} - \phi))s\psi \end{aligned} \quad (2.41)$$

$$\begin{aligned} V_{3i} &= 2(-y_p + x_{2i}s\delta_{1i} + (x_{5i} + x_{7i}c\delta_{6i}))c\theta_{4i}s(\delta_{1i} + \delta_{3i}) + \\ &\quad x_{7i}c(\delta_{1i} + \delta_{3i})s\delta_{6i} - c\theta c\psi(x_{16i}s(\delta_{17i} - \phi) + x_{14i}s(\delta_{15i} + \\ &\quad \delta_{17i} - \phi)) + (x_{16i}c(\delta_{17i} - \phi) + x_{14i}c(\delta_{15i} + \delta_{17i} - \phi))s\psi \\ V_{4i} &= -2(z_p + (x_{5i} + x_{7i}c\delta_{6i}))s\theta_{4i} + s\theta(x_{16i}s(\delta_{17i} - \phi) + \\ &\quad x_{14i}s(\delta_{15i} + \delta_{17i} - \phi)) \\ V_{5i} &= 2(-(x_{16i}c(\delta_{17i} - \phi))(-y_p c\psi) + x_{7i}c(\delta_{1i} + \delta_{3i}) - \psi s\delta_{6i} + \\ &\quad x_{2i}s(\delta_{1i} - \psi) + (x_{5i} + x_{7i}c\delta_{6i}))c\theta_{4i}s(\delta_{1i} + \delta_{3i} - \psi) + \\ &\quad x_p s\psi) - x_{14i}c(\delta_{15i} + \delta_{17i} - \phi)(-y_p c\psi) + x_{7i}c(\delta_{1i} + \delta_{3i} \\ &\quad - \psi)s\delta_{6i} + x_{2i}s\delta_{1i} - \psi + (x_{5i} + x_{7i}c\delta_{6i}))c\theta_{4i}s(\delta_{1i} + \delta_{3i} - \psi) \\ &\quad + x_p s\psi) + c\theta(x_{16i}s(\delta_{17i} - \phi) + x_{14i}s(\delta_{15i} + \delta_{17i} - \phi))(-x_{2i} \\ &\quad c(\delta_{1i} - \psi)) - (x_{5i} + x_{7i}c\delta_{6i}))c\theta_{4i}c(\delta_{1i} + \delta_{3i} - \psi) + x_p c\psi + \\ &\quad x_{7i}s\delta_{6i}s(\delta_{1i} + \delta_{3i} - \psi) + y_p s\psi) \end{aligned} \quad (2.42)$$

$$\begin{aligned} V_{6i} &= 2(x_{16i}s(\delta_{17i} - \phi) + x_{14i}s(\delta_{15i} + \delta_{17i} - \phi))(-c\theta(z_p + (x_{5i} + \\ &\quad x_{7i}c\delta_{6i}))s\theta_{4i}) - s\theta(-y_p c\psi) + x_{7i}c(\delta_{1i} + \delta_{3i}) - \psi s\delta_{6i} + \\ &\quad x_{2i}s(\delta_{1i} - \psi) + (x_{5i} + x_{7i}c\delta_{6i}))c\theta_{4i}s(\delta_{1i} + \delta_{3i} - \psi) + x_p s\psi) \\ V_{7i} &= 2((x_{16i}c(\delta_{17i} - \phi) + x_{14i}c(\delta_{15i} + \delta_{17i} - \phi))s\theta(z_p + \\ &\quad (x_{5i} + x_{7i}c\delta_{6i}))s\theta_{4i}) + c\psi(-x_p + x_{2i}c(\delta_{1i} + c\delta_{1i} + \\ &\quad \delta_{3i})(x_{5i} + x_{7i}c\delta_{6i}))c\theta_{4i} - x_{7i}s(\delta_{1i} + \delta_{3i})s\delta_{6i})(-x_{16i} \\ &\quad s(\delta_{17i} - \phi) - x_{14i}s(\delta_{15i} + \delta_{17i} - \phi)) + (-y_p + x_{2i}s\delta_{1i} + \\ &\quad (x_{5i} + x_{7i}c\delta_{6i}))c\theta_{4i}s(\delta_{1i} + \delta_{3i}) + x_{7i}c(\delta_{1i} + \delta_{3i})s\delta_{6i}) \\ &\quad (-x_{16i}s(\delta_{17i} - \phi) - x_{14i}s(\delta_{15i} + \delta_{17i} - \phi))s\psi - c\theta(x_{16i} \\ &\quad c(\delta_{17i} - \phi) + x_{14i}c(\delta_{15i} + \delta_{17i} - \phi))(-y_p c\psi) + x_{7i}c(\delta_{1i} + \delta_{3i} - \\ &\quad \psi)s\delta_{6i} + x_{2i}s\delta_{1i} - \psi + (x_{5i} + x_{7i}c\delta_{6i}))c\theta_{4i}s(\delta_{1i} + \delta_{3i} - \psi) + \\ &\quad x_p s\psi) \end{aligned}$$

En la Figura 2.13 se muestra la gráfica que describe el comportamiento de la velocidad de los ángulos θ_{4i} del robot Hexa, al recorrer la trayectoria descrita en el apéndice B en un tiempo de 5 segundos.

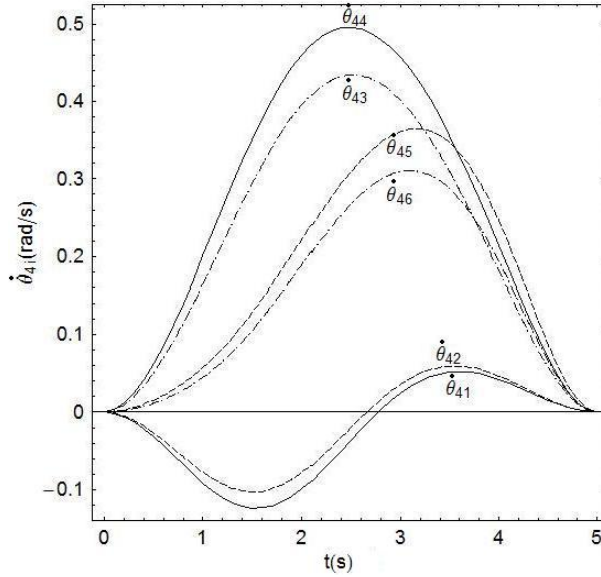
Figura 2.13 Gráfica de la velocidad de θ_{4i}

2.5.2. Velocidad del Ángulo θ_{8i}

De la ecuación (2.18) se tiene:

$$-a_{34i} \tan \theta_{8i} = a_{24i}$$

Derivando esta última expresión:

$$-\tan \theta_{8i} \dot{a}_{34i} - a_{34i} \dot{\theta}_{8i} \sec^2 \theta_{8i} = \dot{a}_{24i} \quad (2.43)$$

Despejando $\dot{\theta}_{8i}$ de la ec. (2.43):

$$\dot{\theta}_{8i} = \frac{(c\theta_{8i})^2 (\dot{a}_{24i} + \tan \theta_{8i} \dot{a}_{34i})}{-a_{34i}} \quad (2.44)$$

Derivando las ecuaciones (2.20) para obtener $(\dot{a}_{24i}, \dot{a}_{34i})$, sustituirlas en (2.44), simplificando y agrupando:

$$\dot{\theta}_{8i} = \frac{1}{V_{8i}} (V_{9i} \dot{x}_p + V_{10i} \dot{y}_p + V_{11i} \dot{z}_p + V_{12i} \dot{\psi} + V_{13i} \dot{\theta} + V_{14i} \dot{\phi} + V_{15i} \dot{\theta}_{4i}) \quad (2.45)$$

Los términos de la ecuación anterior se muestran en el Apéndice C. Finalmente, sustituyendo la ec. (2.40) en (2.45) y agrupando:

$$\dot{\theta}_{8i} = \frac{1}{V_{8i}} (E_{1i} \dot{x}_p + E_{2i} \dot{y}_p + E_{3i} \dot{z}_p + E_{4i} \dot{\psi} + E_{5i} \dot{\theta} + E_{6i} \dot{\phi}) \quad (2.46)$$

Donde:

$$\begin{aligned} E_{1i} &= V_{9i} + \frac{V_{15i} V_{2i}}{V_{1i}} & E_{2i} &= V_{10i} + \frac{V_{15i} V_{3i}}{V_{1i}} \\ E_{3i} &= V_{11i} + \frac{V_{15i} V_{4i}}{V_{1i}} & E_{4i} &= V_{12i} + \frac{V_{15i} V_{5i}}{V_{1i}} \\ E_{5i} &= V_{13i} + \frac{V_{15i} V_{6i}}{V_{1i}} & E_{6i} &= V_{14i} + \frac{V_{15i} V_{7i}}{V_{1i}} \end{aligned} \quad (2.47)$$

En la Figura 2.14 se muestra la gráfica que describe el comportamiento de la velocidad de los ángulos θ_{8i} del robot Hexa, al recorrer la trayectoria descrita en el apéndice B en un tiempo de 5 segundos.



Figura 2.14 Gráfica de la velocidad de θ_{8i}

2.5.3. Velocidad del Ángulo θ_{9i}

De la ecuación (2.21) se tiene:

$$a_{14i} c \theta_{8i} \tan \theta_{9i} = -a_{34i}$$

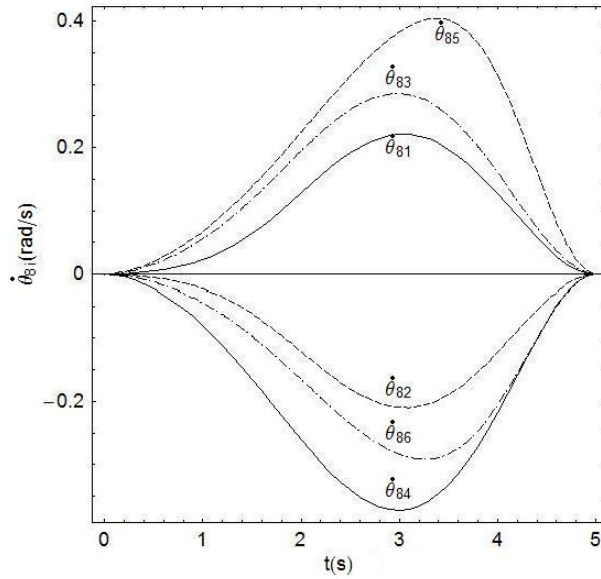
Derivando esta última expresión:

$$c \theta_{8i} \tan \theta_{9i} \dot{a}_{14i} - a_{14i} \dot{\theta}_{8i} s \theta_{8i} \tan \theta_{9i} + a_{14i} c \theta_{8i} (\sec \theta_{9i})^2 \dot{\theta}_{9i} = -\dot{a}_{34i} \quad (2.48)$$

Despejando $\dot{\theta}_{9i}$ de la ec.(2.48):

$$\dot{\theta}_{9i} = - \frac{\sec \theta_{8i} (c \theta_{9i})^2 (\dot{a}_{34i} + \tan \theta_{9i} (c \theta_{8i} \dot{a}_{14i} - a_{14i} \dot{\theta}_{8i} s \theta_{8i}))}{a_{14i}} \quad (2.49)$$

Derivando las ecuaciones (2.20) y (2.23) para obtener $(\dot{a}_{14i}, \dot{a}_{34i})$, sustituirlas en (2.49), simplificando y agrupando:

$$\dot{\theta}_{9i} = \frac{1}{V_{16i}} (V_{17i} \dot{x}_p + V_{18i} \dot{y}_p + V_{19i} \dot{z}_p + V_{20i} \dot{\psi} + V_{21i} \dot{\theta} + V_{22i} \dot{\phi} + V_{23i} \dot{\theta}_{4i} + V_{24i} \dot{\theta}_{8i}) \quad (2.50)$$

Los términos de la ecuación anterior se muestran en el Apéndice C. Finalmente, sustituyendo las ecs. (2.40) y (2.46) en (2.50) y agrupando:

$$\dot{\theta}_{9i} = \frac{1}{V_{16i}} (E_{7i} \dot{x}_p + E_{8i} \dot{y}_p + E_{9i} \dot{z}_p + E_{10i} \dot{\psi} + E_{11i} \dot{\theta} + E_{12i} \dot{\phi}) \quad (2.51)$$

Donde:

$$\begin{aligned}
 E_{7i} &= V_{17i} + \frac{V_{23i}V_{2i}}{V_{1i}} + \frac{E_{1i}V_{24i}}{V_{8i}} & E_{8i} &= V_{18i} + \frac{V_{23i}V_{3i}}{V_{1i}} + \frac{E_{2i}V_{24i}}{V_{8i}} \\
 E_{9i} &= V_{19i} + \frac{V_{23i}V_{4i}}{V_{1i}} + \frac{E_{3i}V_{24i}}{V_{8i}} & E_{10i} &= V_{20i} + \frac{V_{23i}V_{5i}}{V_{1i}} + \frac{E_{4i}V_{24i}}{V_{8i}} \\
 E_{11i} &= V_{21i} + \frac{V_{23i}V_{6i}}{V_{1i}} + \frac{E_{5i}V_{24i}}{V_{8i}} & E_{12i} &= V_{22i} + \frac{V_{23i}V_{7i}}{V_{1i}} + \frac{E_{6i}V_{24i}}{V_{8i}}
 \end{aligned} \tag{2.52}$$

En la Figura 2.15 se muestra la gráfica que describe el comportamiento de la velocidad de los ángulos θ_{9i} del robot Hexa, al recorrer la trayectoria descrita en el apéndice B en un tiempo de 5 segundos.



Figura 2.15 Gráfica de la velocidad de θ_{9i}

2.5.4. Velocidad del Ángulo θ_{11i}

De la ecuación (2.28) se tiene:

$$-c_{23i} \tan \theta_{11i} = c_{13i}$$

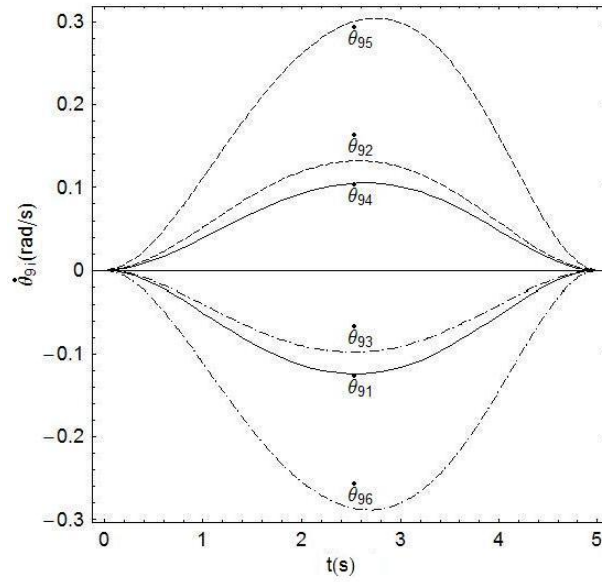
Derivando esta última expresión:

$$-\tan \theta_{11i} \dot{c}_{23i} - c_{23i} \dot{\theta}_{11i} \sec^2 \theta_{11i} = \dot{c}_{13i} \tag{2.53}$$

Despejando $\dot{\theta}_{11i}$ de la ec.(2.53):

$$\dot{\theta}_{11i} = \frac{(c_{13i})^2 (\dot{c}_{13i} + \tan \theta_{11i} \dot{c}_{23i})}{-c_{23i}} \tag{2.54}$$

Derivando las ecuaciones (2.30) para obtener $(\dot{c}_{13i}, \dot{c}_{23i})$, sustituirlas en (2.54), simplificando y agrupando:

$$\dot{\theta}_{11i} = \frac{1}{V_{25i}} \left(V_{26i} \dot{x}_p + V_{27i} \dot{y}_p + V_{28i} \dot{z}_p + V_{29i} \dot{\psi} + V_{30i} \dot{\theta} + V_{31i} \dot{\phi} + V_{32i} \dot{\theta}_4 + V_{33i} \dot{\theta}_8 + V_{34i} \dot{\theta}_9 \right) \tag{2.55}$$

Los términos de la ecuación anterior se muestran en el Apéndice C.

Finalmente, sustituyendo las ecs. (2.40), (2.46), (2.51) en (2.55) y agrupando:

$$\dot{\theta}_{11i} = \frac{1}{V_{25i}} (E_{13i}\dot{x}_p + E_{14i}\dot{y}_p + E_{15i}\dot{z}_p + E_{16i}\dot{\psi} + E_{17i}\dot{\theta} + E_{18i}\dot{\phi}) \quad (2.56)$$

Donde los coeficientes son:

$$\begin{aligned} E_{13i} &= V_{26i} + \frac{V_{2i}V_{32i}}{V_{1i}} + \frac{E_{1i}V_{33i}}{V_{8i}} + \frac{E_{7i}V_{34i}}{V_{16i}} & E_{14i} &= V_{27i} + \frac{V_{3i}V_{32i}}{V_{1i}} + \frac{E_{2i}V_{33i}}{V_{8i}} + \frac{E_{8i}V_{34i}}{V_{16i}} \\ E_{15i} &= V_{28i} + \frac{V_{4i}V_{32i}}{V_{1i}} + \frac{E_{3i}V_{33i}}{V_{8i}} + \frac{E_{9i}V_{34i}}{V_{16i}} & E_{16i} &= V_{29i} + \frac{V_{5i}V_{32i}}{V_{1i}} + \frac{E_{4i}V_{33i}}{V_{8i}} + \frac{E_{10i}V_{34i}}{V_{16i}} \\ E_{17i} &= V_{30i} + \frac{V_{6i}V_{32i}}{V_{1i}} + \frac{E_{5i}V_{33i}}{V_{8i}} + \frac{E_{11i}V_{34i}}{V_{16i}} & E_{18i} &= V_{31i} + \frac{V_{7i}V_{32i}}{V_{1i}} + \frac{E_{6i}V_{33i}}{V_{8i}} + \frac{E_{12i}V_{34i}}{V_{16i}} \end{aligned} \quad (2.57)$$

En la Figura 2.16 se muestra la gráfica que describe el comportamiento de la velocidad de los ángulos θ_{11i} del robot Hexa, al recorrer la trayectoria descrita en el apéndice B en un tiempo de 5 segundos.



Figura 2.16 Gráfica de la velocidad de θ_{11i}

2.5.5. Velocidad del Ángulo θ_{13i}

De la ecuación (2.31) se tiene:

$$c_{32i} \tan \theta_{13i} = c_{31i}$$

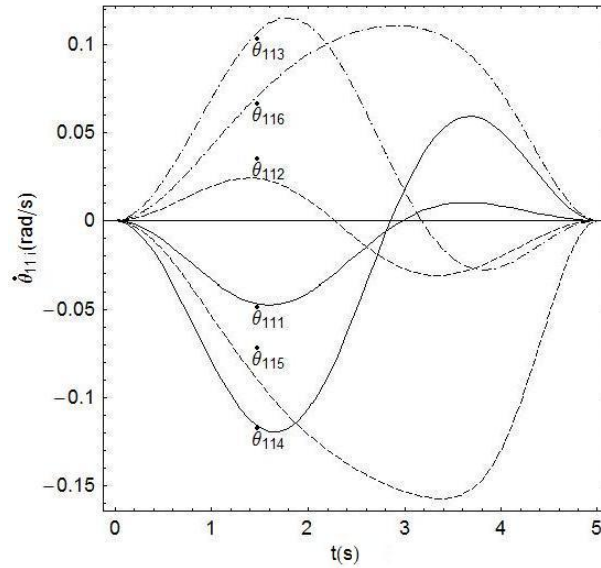
Derivando esta última expresión:

$$\tan \theta_{11i} \dot{c}_{32i} + c_{32i} \dot{\theta}_{13i} \sec^2 \theta_{13i} = \dot{c}_{31i} \quad (2.58)$$

Despejando $\dot{\theta}_{13i}$ de la ec. (2.58):

$$\dot{\theta}_{13i} = \frac{(c \theta_{13i})^2 (\dot{c}_{31i} - \tan \theta_{11i} \dot{c}_{32i})}{c_{32i}} \quad (2.59)$$

Derivando las ecuaciones (2.33) para obtener $(\dot{c}_{31i}, \dot{c}_{32i})$, sustituirlas en (2.59), simplificando y agrupando:

$$\dot{\theta}_{13i} = \frac{1}{V_{35i}} \left(V_{36i} \dot{x}_p + V_{37i} \dot{y}_p + V_{38i} \dot{z}_p + V_{39i} \dot{\psi} + V_{40i} \dot{\theta} + V_{41i} \dot{\phi} + V_{42i} \dot{\theta}_{4i} + V_{43i} \dot{\theta}_{8i} + V_{44i} \dot{\theta}_{9i} \right) \quad (2.60)$$

Los términos de la ecuación anterior se muestran en el Apéndice C. Finalmente, sustituyendo las ecs. (2.40), (2.46), (2.51) en (2.60) y agrupando:

$$\dot{\theta}_{13i} = \frac{1}{V_{35i}} \left(E_{19i} \dot{x}_p + E_{20i} \dot{y}_p + E_{21i} \dot{z}_p + E_{22i} \dot{\psi} + E_{23i} \dot{\theta} + E_{24i} \dot{\phi} \right) \quad (2.61)$$

Donde los coeficientes son:

$$\begin{aligned} E_{19i} &= V_{36i} + \frac{V_{2i} V_{42i}}{V_{1i}} + \frac{E_{1i} V_{43i}}{V_{8i}} + \frac{E_{7i} V_{44i}}{V_{16i}} & E_{20i} &= V_{37i} + \frac{V_{3i} V_{42i}}{V_{1i}} + \frac{E_{2i} V_{43i}}{V_{8i}} + \frac{E_{8i} V_{44i}}{V_{16i}} \\ E_{21i} &= V_{38i} + \frac{V_{4i} V_{42i}}{V_{1i}} + \frac{E_{3i} V_{43i}}{V_{8i}} + \frac{E_{9i} V_{44i}}{V_{16i}} & E_{22i} &= V_{39i} + \frac{V_{5i} V_{42i}}{V_{1i}} + \frac{E_{4i} V_{43i}}{V_{8i}} + \frac{E_{10i} V_{44i}}{V_{16i}} \\ E_{23i} &= V_{40i} + \frac{V_{6i} V_{42i}}{V_{1i}} + \frac{E_{5i} V_{43i}}{V_{8i}} + \frac{E_{11i} V_{44i}}{V_{16i}} & E_{24i} &= V_{41i} + \frac{V_{7i} V_{42i}}{V_{1i}} + \frac{E_{6i} V_{43i}}{V_{8i}} + \frac{E_{12i} V_{44i}}{V_{16i}} \end{aligned} \quad (2.62)$$

En la Figura 2.17 se muestra la gráfica que describe el comportamiento de la velocidad de los ángulos θ_{13i} del robot Hexa, al recorrer la trayectoria descrita en el apéndice B en un tiempo de 5 segundos.



Figura 2.17 Gráfica de la velocidad de θ_{13i}

2.5.6. Velocidad del Ángulo θ_{12i}

De la ecuación (2.34) se tiene:

$$(c_{21i} - c\theta_{13i}s\theta_{11i}) \tan \theta_{12i} = c_{31i} c\theta_{11i}$$

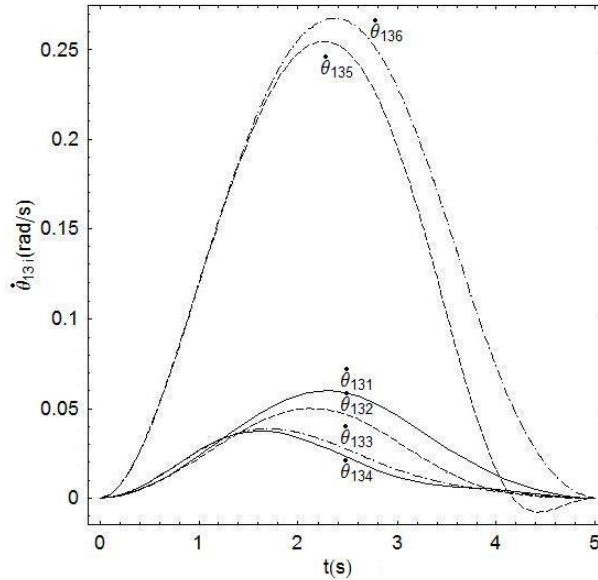
Derivando esta última expresión:

$$(\sec \theta_{12i})^2 (c_{21i} - c\theta_{13i}s\theta_{11i}) \dot{\theta}_{12i} + \tan \theta_{12i} (\dot{c}_{21i} - \dot{\theta}_{11i} c\theta_{13i} c\theta_{11i} + \dot{\theta}_{13i} s\theta_{13i} s\theta_{11i}) = \dot{c}_{31i} c\theta_{11i} - \dot{\theta}_{11i} c_{31i} s\theta_{11i} \quad (2.63)$$

Despejando $\dot{\theta}_{12i}$ de la ec. (2.63):

$$\dot{\theta}_{12i} = \frac{-(c\theta_{12i})^2 \left[(\dot{\theta}_{11i} c_{31i} s\theta_{11i} - \dot{c}_{31i} c\theta_{11i}) + \tan\theta_{12i} (\dot{c}_{21i} - \dot{\theta}_{11i} c\theta_{13i} c\theta_{11i} + \dot{\theta}_{13i} s\theta_{13i} s\theta_{11i}) \right]}{(c_{21i} - c\theta_{13i} s\theta_{11i})} \quad (2.64)$$

Derivando las ecuaciones (2.33) y (2.36) para obtener $(\dot{c}_{21i}, \dot{c}_{31i})$, sustituirlas en (2.64), simplificando y agrupando:

$$\dot{\theta}_{12i} = \frac{1}{V_{45i}} (V_{46i} \dot{x}_p + V_{47i} \dot{y}_p + V_{48i} \dot{z}_p + V_{49i} \dot{\psi} + V_{50i} \dot{\theta} + V_{51i} \dot{\phi} + V_{52i} \dot{\theta}_{4i} + V_{53i} \dot{\theta}_{8i} + V_{54i} \dot{\theta}_{9i} + V_{55i} \dot{\theta}_{11i} + V_{56i} \dot{\theta}_{13i}) \quad (2.65)$$

Los términos de la ecuación anterior se muestran en el Apéndice C. Finalmente, sustituyendo las ecs. (2.40), (2.46), (2.51), (2.56), (2.61) en (2.65) y agrupando:

$$\dot{\theta}_{12i} = \frac{1}{V_{45i}} (E_{25i} \dot{x}_p + E_{26i} \dot{y}_p + E_{27i} \dot{z}_p + E_{28i} \dot{\psi} + E_{29i} \dot{\theta} + E_{30i} \dot{\phi}) \quad (2.66)$$

Donde los coeficientes son:

$$\begin{aligned} E_{25i} &= V_{46i} + \frac{V_{2i} V_{52i}}{V_{1i}} + \frac{E_{1i} V_{53i}}{V_{8i}} + \frac{E_{7i} V_{54i}}{V_{16i}} + \frac{E_{13i} V_{55i}}{V_{25i}} + \frac{E_{19i} V_{56i}}{V_{35i}} \\ E_{26i} &= V_{47i} + \frac{V_{3i} V_{52i}}{V_{1i}} + \frac{E_{2i} V_{53i}}{V_{8i}} + \frac{E_{8i} V_{54i}}{V_{16i}} + \frac{E_{14i} V_{55i}}{V_{25i}} + \frac{E_{20i} V_{56i}}{V_{35i}} \\ E_{27i} &= V_{48i} + \frac{V_{4i} V_{52i}}{V_{1i}} + \frac{E_{3i} V_{53i}}{V_{8i}} + \frac{E_{9i} V_{54i}}{V_{16i}} + \frac{E_{15i} V_{55i}}{V_{25i}} + \frac{E_{21i} V_{56i}}{V_{35i}} \\ E_{28i} &= V_{49i} + \frac{V_{5i} V_{52i}}{V_{1i}} + \frac{E_{4i} V_{53i}}{V_{8i}} + \frac{E_{10i} V_{54i}}{V_{16i}} + \frac{E_{16i} V_{55i}}{V_{25i}} + \frac{E_{22i} V_{56i}}{V_{35i}} \\ E_{29i} &= V_{50i} + \frac{V_{6i} V_{52i}}{V_{1i}} + \frac{E_{5i} V_{53i}}{V_{8i}} + \frac{E_{11i} V_{54i}}{V_{16i}} + \frac{E_{17i} V_{55i}}{V_{25i}} + \frac{E_{23i} V_{56i}}{V_{35i}} \\ E_{30i} &= V_{51i} + \frac{V_{7i} V_{52i}}{V_{1i}} + \frac{E_{6i} V_{53i}}{V_{8i}} + \frac{E_{12i} V_{54i}}{V_{16i}} + \frac{E_{18i} V_{55i}}{V_{25i}} + \frac{E_{24i} V_{56i}}{V_{35i}} \end{aligned} \quad (2.67)$$

En la Figura 2.18 se muestra la gráfica que describe el comportamiento de la velocidad de los ángulos θ_{12i} del robot Hexa, al recorrer la trayectoria descrita en el apéndice B en un tiempo de 5 segundos.



Figura 2.18 Gráfica de la velocidad de θ_{12i}

2.6. Cálculo de Aceleración

En el problema cinemático inverso de la aceleración, se tiene que, dada la aceleración $(\ddot{x}_p, \ddot{y}_p, \ddot{z}_p, \ddot{\psi}, \ddot{\theta}, \ddot{\phi})$ del plato móvil, hallar la aceleración de los ángulos $\ddot{\theta}_{4i}, \ddot{\theta}_{8i}, \ddot{\theta}_{9i}, \ddot{\theta}_{11i}, \ddot{\theta}_{12i}, \ddot{\theta}_{13i}$ que se encuentran en las juntas del robot.

La aceleración de un punto o un cuerpo rígido que experimenta movimiento, puede ser obtenida por la derivada respecto al tiempo de su función de velocidad. Se asume en esta sección que la posición, orientación y velocidad de los cuerpos son totalmente conocidas, ya que son resultado del análisis de posición y velocidad. Por lo tanto, con base en las ecuaciones obtenidas en las secciones anteriores, se obtendrá la aceleración al derivar con respecto al tiempo cada una de ellas.

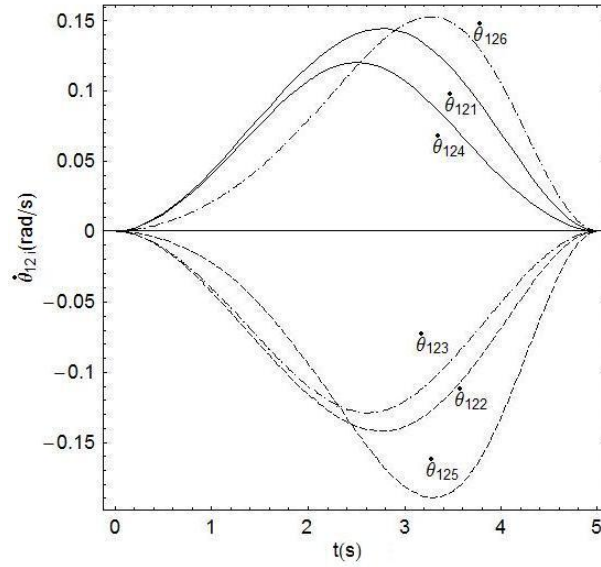
2.6.1. Aceleración del Ángulo θ_{4i}

Tomando la ec. (2.37) y derivando respecto al tiempo obtenemos:

$$\begin{aligned} \dot{A}_{1i}c\theta_{4i} - A_{1i}s\theta_{4i}\dot{\theta}_{4i} + \dot{B}_{1i}s\theta_{4i} + B_{1i}c\theta_{4i}\dot{\theta}_{4i} + \dot{C}_{1i} &= 0 \\ (c\theta_{4i}B_{1i} - s\theta_{4i}A_{1i})\ddot{\theta}_{4i} + c\theta_{4i}(\ddot{A}_{1i} - A_{1i}\dot{\theta}_{4i}^2 + 2\dot{B}_{1i}\dot{\theta}_{4i}) + s\theta_{4i}(\ddot{B}_{1i} - B_{1i}\dot{\theta}_{4i}^2 - 2\dot{A}_{1i}\dot{\theta}_{4i}) + \ddot{C}_{1i} &= 0 \end{aligned} \quad (2.68)$$

Despejando $\ddot{\theta}_{4i}$ y simplificando se tiene:

$$\ddot{\theta}_{4i} = \frac{-c\theta_{4i}(\ddot{A}_{1i} - A_{1i}\dot{\theta}_{4i}^2 + 2\dot{B}_{1i}\dot{\theta}_{4i}) - s\theta_{4i}(\ddot{B}_{1i} - B_{1i}\dot{\theta}_{4i}^2 - 2\dot{A}_{1i}\dot{\theta}_{4i}) - \ddot{C}_{1i}}{(B_{1i}c\theta_{4i} - A_{1i}s\theta_{4i})} \quad (2.69)$$

Donde $A_{1i}, B_{1i}, C_{1i}, \dot{A}_{1i}, \dot{B}_{1i}, \dot{C}_{1i}$ se encuentran en los análisis de posición y velocidad, además:

$$\begin{aligned}
\ddot{A}_{1i} &= 2(x_{5i} + x_{7i}c\delta_{6i})(-\dot{x}_p c(\delta_{1i} + \delta_{3i})) - \dot{y}_p s(\delta_{1i} + \delta_{3i}) + \dot{\phi} \\
&\quad c(\delta_{1i} + \delta_{3i} - \psi)(x_{16i}s(\delta_{17i} - \phi) + x_{14i}s(\delta_{15i} + \delta_{17i} - \phi)) + \dot{\psi} \\
&\quad c\theta c(\delta_{1i} + \delta_{3i} - \psi)(x_{16i}s(\delta_{17i} - \phi) + x_{14i}s(\delta_{15i} + \delta_{17i} - \phi)) + \\
&\quad \dot{\psi}(x_{16i}c(\delta_{17i} - \phi) + x_{14i}c(\delta_{15i} + \delta_{17i} - \phi))s(\delta_{1i} + \delta_{3i} - \psi) + \\
&\quad \dot{\phi}c\theta(x_{16i}c(\delta_{17i} - \phi) + x_{14i}c(\delta_{15i} + \delta_{17i} - \phi))s(\delta_{1i} + \delta_{3i} - \psi) + \\
&\quad \dot{\theta}s\theta(x_{16i}s(\delta_{17i} - \phi) + x_{14i}s(\delta_{15i} + \delta_{17i} - \phi))s(\delta_{1i} + \delta_{3i} - \psi) \\
\ddot{B}_{1i} &= 2(x_{5i} + x_{7i}c\delta_{6i})(\dot{z}_p - \dot{\phi}(x_{16i}c(\delta_{17i} - \phi) + x_{14i}c(\delta_{15i} + \delta_{17i} - \phi))) \\
&\quad s\theta + \dot{\theta}c\theta(x_{16i}s(\delta_{17i} - \phi) + x_{14i}s(\delta_{15i} + \delta_{17i} - \phi)) \\
\ddot{C}_{1i} &= 2\dot{x}_p x_p + 2\dot{y}_p y_p + 2\dot{z}_p z_p + (-4\dot{x}_p x_{2i}c\delta_{1i} - 4\dot{x}_p(x_{16i}c(\delta_{17i} - \phi) + \\
&\quad x_{14i}c(\delta_{15i} + \delta_{17i} - \phi))c\psi - 4\dot{y}_p x_{2i}s\delta_{1i} - 4\dot{\psi}(x_{16i}c(\delta_{17i} - \phi) + \\
&\quad x_{14i}c(\delta_{15i} + \delta_{17i} - \phi))c\psi(y_p - x_{2i}s\delta_{1i}) + 4z_p(-(\dot{\phi}x_{16i}c(\delta_{17i} - \phi)) - \\
&\quad \dot{\phi}x_{14i}c(\delta_{15i} + \delta_{17i} - \phi))s\theta + 4\dot{\theta}z_p c\theta(x_{16i}s(\delta_{17i} - \phi) + x_{14i} \\
&\quad s(\delta_{15i} + \delta_{17i} - \phi)) + 4\dot{z}_p s\theta(x_{16i}s(\delta_{17i} - \phi) + x_{14i}s(\delta_{15i} + \delta_{17i} - \phi)) \\
&\quad 4(x_p - x_{2i}c\delta_{1i})c\psi(\dot{\phi}x_{16i}s(\delta_{17i} - \phi) + \dot{\phi}x_{14i}s(\delta_{15i} + \delta_{17i} - \phi)) - 4x_{7i} \\
&\quad s\delta_{6i}(\dot{y}_p c(\delta_{1i} + \delta_{3i}) - \dot{\psi}(x_{16i}c(\delta_{17i} - \phi) + x_{14i}c(\delta_{15i} + \delta_{17i} - \phi)) \\
&\quad c(\delta_{1i} + \delta_{3i} - \psi) - \dot{x}_p s(\delta_{1i} + \delta_{3i})) + (\dot{\phi}x_{16i}s(\delta_{17i} - \phi) + \dot{\phi}x_{14i} \\
&\quad s(\delta_{15i} + \delta_{17i} - \phi))s(\delta_{1i} + \delta_{3i} - \psi) - 4\dot{y}_p(x_{16i}c(\delta_{17i} - \phi) + x_{14i} \\
&\quad c(\delta_{15i} + \delta_{17i} - \phi))s\psi + 4\dot{\psi}(x_p - x_{2i}c\delta_{1i})(x_{16i}c(\delta_{17i} - \phi) + x_{14i} \\
&\quad c(\delta_{15i} + \delta_{17i} - \phi))s\psi - 4(y_p - x_{2i}s\delta_{1i})(\dot{\phi}x_{16i}s(\delta_{17i} - \phi) + \dot{\phi}x_{14i} \\
&\quad s(\delta_{15i} + \delta_{17i} - \phi))s\psi - 4c\theta(-(\dot{\phi}x_{16i}c(\delta_{17i} - \phi)) - \dot{\phi}x_{14i} \\
&\quad c(\delta_{15i} + \delta_{17i} - \phi))(-y_p c\psi) + x_{7i}c(\delta_{1i} + \delta_{3i} - \psi)s\delta_{6i} + x_{2i} \\
&\quad s(\delta_{1i} - \psi) + x_p s\psi) + 4\dot{\theta}s\theta(x_{16i}s(\delta_{17i} - \phi) + x_{14i} \\
&\quad s(\delta_{15i} + \delta_{17i} - \phi))(-y_p c\psi) + x_{7i}c(\delta_{1i} + \delta_{3i} - \psi)s\delta_{6i} + \\
&\quad x_{2i}s\delta_{1i} - \psi + x_p s\psi) - 4c\theta(x_{16i}s(\delta_{17i} - \phi) + x_{14i} \\
&\quad s(\delta_{15i} + \delta_{17i} - \phi))(-\dot{\psi}x_{2i}c\delta_{1i} - \psi) - \dot{y}_p c\psi + \dot{\psi}x_p c\psi + \\
&\quad \dot{\psi}x_{7i}s\delta_{6i}s(\delta_{1i} + \delta_{3i} - \psi) + \dot{x}_p s\psi + \dot{\psi}y_p s\psi) / 4
\end{aligned}$$

Sustituyendo A_{1i} , B_{1i} , C_{1i} , \dot{A}_{1i} , \dot{B}_{1i} , \dot{C}_{1i} , \ddot{A}_{1i} , \ddot{B}_{1i} , \ddot{C}_{1i} en la ecuación (2.69), para después agrupar en \ddot{x}_p , \ddot{y}_p , \ddot{z}_p , $\ddot{\psi}$, $\ddot{\theta}$, $\ddot{\phi}$, se tiene:

$$\ddot{\theta}_{4i} = \frac{1}{V_{1i}} (G_{1i}\ddot{x}_p + G_{2i}\ddot{y}_p + G_{3i}\ddot{z}_p + G_{4i}\ddot{\psi} + G_{5i}\ddot{\theta} + G_{6i}\ddot{\phi} + G_{7i}) \quad (2.70)$$

Los coeficientes de la ecuación (2.70) se encuentran en el Apéndice D. En la Figura 2.19 se muestra la gráfica que describe el comportamiento de la aceleración de los ángulos θ_{4i} del robot Hexa, al recorrer la trayectoria descrita en el apéndice B en un tiempo de 5 segundos.



Figura 2.19 Gráfica de la aceleración de θ_{4i}

2.6.2. Aceleración del Ángulo θ_{8i}

De la ecuación (2.43) se tiene:

$$-\tan \theta_{8i} \dot{a}_{34i} - a_{34i} \dot{\theta}_{8i} \sec^2 \theta_{8i} = \dot{a}_{24i}$$

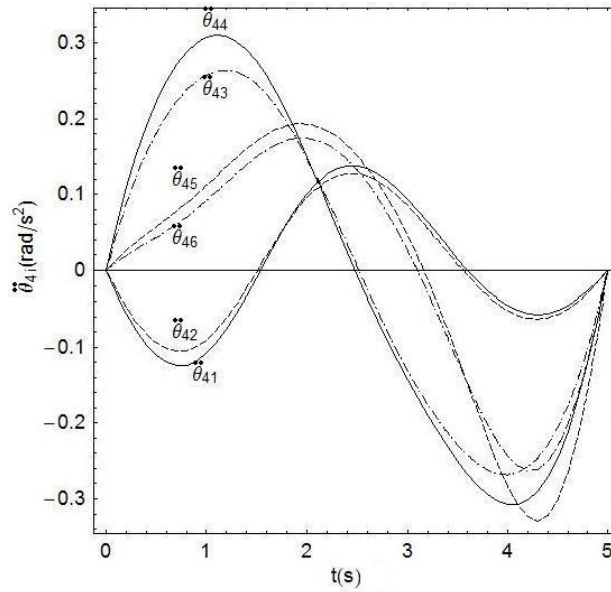
Derivando la expresión anterior:

$$\tan \theta_{8i} \ddot{a}_{34i} + 2\dot{a}_{34i} \dot{\theta}_{8i} \sec^2 \theta_{8i} + a_{34i} \sec^2 \theta_{8i} (\ddot{\theta}_{8i} + 2\dot{\theta}_{8i} \tan \theta_{8i}) = -\ddot{a}_{24i} \tag{2.71}$$



Figura 2.20 Gráfica de la aceleración de θ_{8i}

Despejando $\ddot{\theta}_{8i}$ de la ec. (2.71):

$$\ddot{\theta}_{8i} = \frac{(c\theta_{8i}(c\theta_{8i}\ddot{a}_{24i} + s\theta_{8i}\ddot{a}_{34i}) + 2\dot{\theta}_{8i}(\dot{a}_{34i} + a_{34i}\dot{\theta}_{8i}\tan\theta_{8i}))}{-a_{34i}} \quad (2.72)$$

Donde a_{24i} , a_{34i} , \dot{a}_{24i} , \dot{a}_{34i} se encuentran en los análisis de posición y velocidad, además derivando dos veces las ecuaciones (2.20) para obtener $(\ddot{a}_{24i}, \ddot{a}_{34i})$, sustituirlas en (2.72) y simplificando se tiene:

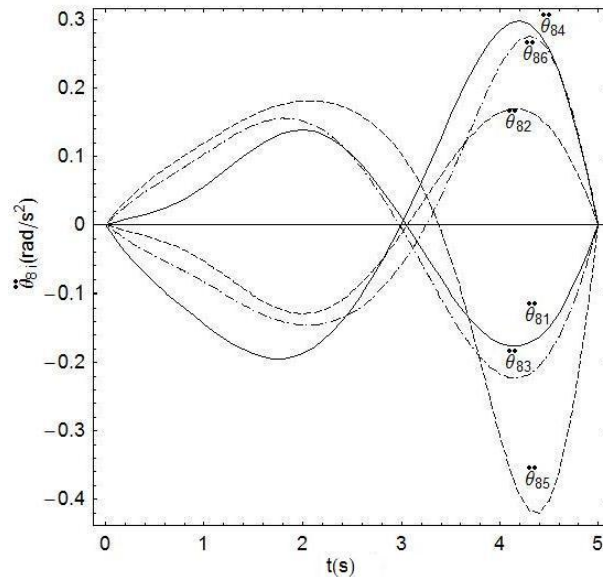
$$\ddot{\theta}_{8i} = \frac{1}{V_{8i}} (G_{8i}\ddot{x}_p + G_{9i}\ddot{y}_p + G_{10i}\ddot{z}_p + G_{11i}\ddot{\psi} + G_{12i}\ddot{\theta} + G_{13i}\ddot{\phi} + G_{14i}) \quad (2.73)$$

Los coeficientes de la ecuación (2.73) se encuentran en el Apéndice D. En la Figura 2.20 se muestra la gráfica que describe el comportamiento de la aceleración de los ángulos θ_{8i} del robot Hexa, al recorrer la trayectoria descrita en el apéndice B en un tiempo de 5 segundos.

2.6.3. Aceleración del Ángulo θ_{9i}

De la ecuación (2.48) se tiene:

$$c\theta_{8i}\tan\theta_{9i}\dot{a}_{14i} - a_{14i}\dot{\theta}_{8i}s\theta_{8i}\tan\theta_{9i} + a_{14i}c\theta_{8i}(\sec\theta_{9i})^2\dot{\theta}_{9i} = -\dot{a}_{34i}$$

Derivando la expresión anterior:

$$\begin{aligned} a_{14i}(c\theta_{8i}\tan\theta_{9i}\dot{\theta}_{8i}^2 + 2(\sec\theta_{9i})^2s\theta_{8i}\dot{\theta}_{8i}\dot{\theta}_{9i} - 2c\theta_{8i}(\sec\theta_{9i})^2\tan\theta_{9i}\dot{\theta}_{9i}^2 + s\theta_{8i}\tan\theta_{9i}\ddot{\theta}_{8i} - \\ c\theta_{8i}(\sec\theta_{9i})^2\ddot{\theta}_{9i}) - \dot{a}_{14i}(2s\theta_{8i}\tan\theta_{9i}\dot{\theta}_{8i} + 2c\theta_{8i}(\sec\theta_{9i})^2\dot{\theta}_{9i}) - c\theta_{8i}\tan\theta_{9i}\ddot{a}_{14i} = \ddot{a}_{34i} \end{aligned} \quad (2.74)$$

Despejando $\ddot{\theta}_{9i}$ de la ec. (2.74):

$$\begin{aligned} \frac{1}{a_{14i}}(\dot{a}_{14i}(s(2\theta_{9i})\tan\theta_{8i}\dot{\theta}_{8i} - 2\dot{\theta}_{9i}) - (c\theta_{9i}s\theta_{9i}\ddot{a}_{14i} + c\theta_{9i}\sec\theta_{8i}\ddot{a}_{34i}) + a_{14i}(c\theta_{9i}s\theta_{9i}\dot{\theta}_{8i}^2 + \\ 2\dot{\theta}_{8i}\dot{\theta}_{9i}\tan\theta_{8i} - 2\dot{\theta}_{9i}^2\tan\theta_{9i} + c\theta_{9i}s\theta_{9i}\tan\theta_{8i}\ddot{\theta}_{8i})) = \ddot{\theta}_{9i} \end{aligned} \quad (2.75)$$



Figura 2.21 Gráfica de la aceleración de θ_{9i}

Donde $a_{14i}, a_{34i}, \dot{a}_{14i}, \dot{a}_{34i}$ se encuentran en los análisis de posición y velocidad, además derivando dos veces las ecuaciones (2.20) y (2.23) para obtener $(\ddot{a}_{14i}, \ddot{a}_{34i})$, sustituirlas en (2.75) y simplificando se tiene:

$$\ddot{\theta}_{9i} = \frac{1}{-V_{16i}} (G_{15i} \ddot{x}_p + G_{16i} \ddot{y}_p + G_{17i} \ddot{z}_p + G_{18i} \ddot{\psi} + G_{19i} \ddot{\theta} + G_{20i} \ddot{\phi} + G_{21i}) \quad (2.76)$$

Los coeficientes de la ecuación (2.76) se encuentran en el Apéndice D. En la Figura 2.21 se muestra la gráfica que describe el comportamiento de la aceleración de los ángulos θ_{9i} del robot Hexa, al recorrer la trayectoria descrita en el apéndice B en un tiempo de 5 segundos.

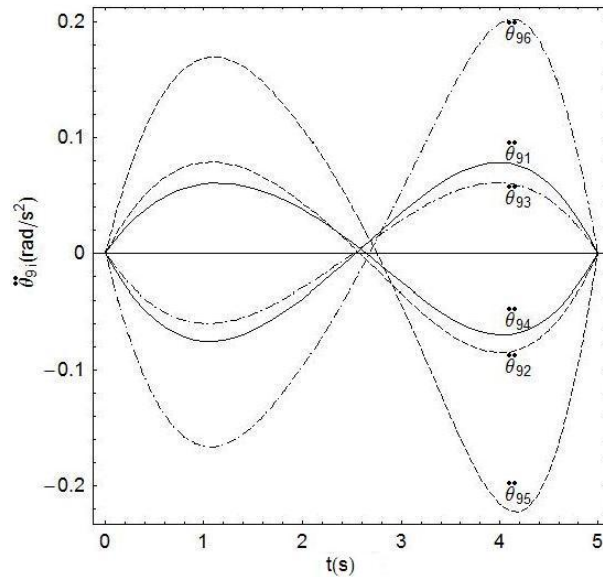
2.6.4. Aceleración del Ángulo θ_{11i}

De la ecuación (2.53) se tiene:

$$-\tan \theta_{11i} \dot{c}_{23i} - c_{23i} \dot{\theta}_{11i} \sec^2 \theta_{11i} = \dot{c}_{13i}$$

Derivando la expresión anterior:

$$-2\dot{c}_{23i} \dot{\theta}_{11i} \sec^2 \theta_{11i} - \ddot{c}_{23i} \tan \theta_{11i} - c_{23i} \ddot{\theta}_{11i} \sec^2 \theta_{11i} - 2c_{23i} \dot{\theta}_{11i}^2 \tan \theta_{11i} \sec^2 \theta_{11i} = \ddot{c}_{13i} \quad (2.77)$$

Despejando $\ddot{\theta}_{11i}$ de la ec.(2.77):

$$\ddot{\theta}_{11i} = \left(\frac{1}{-c_{23i}} \right) (2\dot{\theta}_{11i} (\dot{c}_{23i} + c_{23i} \dot{\theta}_{11i} \tan \theta_{11i}) + c \theta_{11i} (c \theta_{11i} \ddot{c}_{13i} + \ddot{c}_{23i} s \theta_{11i})) \quad (2.78)$$



Figura 2.22 Gráfica de la aceleración de θ_{11i}

Donde $c_{13i}, c_{23i}, \dot{c}_{13i}, \dot{c}_{23i}$ se encuentran en los análisis de posición y velocidad, además derivando dos veces las ecuaciones (2.30) para obtener $(\ddot{c}_{13i}, \ddot{c}_{23i})$, sustituirlas en (2.78) y simplificando se tiene:

$$\ddot{\theta}_{11i} = \frac{1}{V_{25i}} (G_{22i} \ddot{x}_p + G_{23i} \ddot{y}_p + G_{24i} \ddot{z}_p + G_{25i} \ddot{\psi} + G_{26i} \ddot{\theta} + G_{27i} \ddot{\phi} + G_{28i}) \quad (2.79)$$

Los coeficientes de la ecuación (2.79) se encuentran en el Apéndice D. En la Figura 2.22 se muestra la gráfica que describe el comportamiento de la aceleración de los ángulos θ_{11i} del robot Hexa, al recorrer la trayectoria descrita en el apéndice B en un tiempo de 5 segundos.

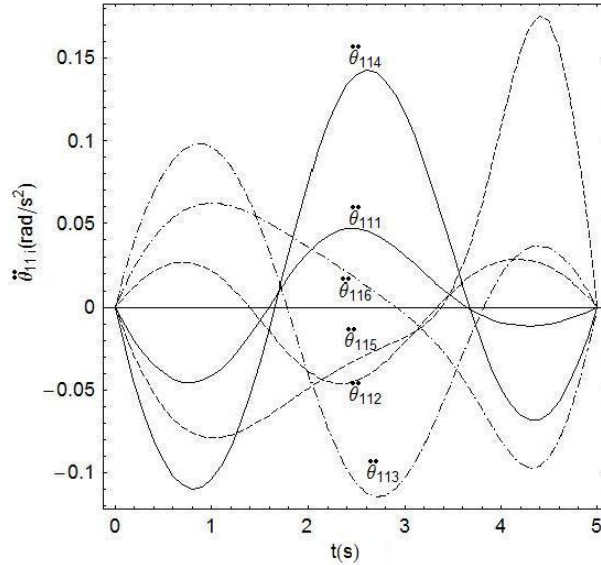
2.6.5. Aceleración del Ángulo θ_{13i}

De la ecuación (2.58) se tiene:

$$\tan \theta_{11i} \dot{c}_{32i} + c_{32i} \dot{\theta}_{13i} \sec^2 \theta_{13i} = \dot{c}_{31i}$$

Derivando la expresión anterior:

$$2\dot{c}_{32i} \dot{\theta}_{13i} \sec^2 \theta_{13i} + \ddot{c}_{32i} \tan \theta_{13i} + c_{32i} \ddot{\theta}_{13i} \sec^2 \theta_{13i} + 2c_{32i} \dot{\theta}_{13i}^2 \tan \theta_{13i} \sec^2 \theta_{13i} = \ddot{c}_{31i} \quad (2.80)$$

Despejando $\ddot{\theta}_{13i}$ de la ec. (2.80):

$$\ddot{\theta}_{13i} = \left(\frac{1}{c_{32i}} \right) \left(-2\dot{\theta}_{13i} (\dot{c}_{32i} + c_{32i} \dot{\theta}_{13i} \tan \theta_{13i}) + c \theta_{13i} (\ddot{c}_{31i} c \theta_{13i} - \ddot{c}_{32i} s \theta_{13i}) \right) \quad (2.81)$$

Donde $c_{31i}, c_{32i}, \dot{c}_{31i}, \dot{c}_{32i}$ se encuentran en los análisis de posición y velocidad, además derivando dos veces las ecuaciones (2.33) para obtener $(\ddot{c}_{31i}, \ddot{c}_{32i})$, sustituirlas en (2.81) y simplificando se tiene:

$$\ddot{\theta}_{13i} = \frac{1}{V_{35i}} (G_{29i} \ddot{x}_p + G_{30i} \ddot{y}_p + G_{31i} \ddot{z}_p + G_{32i} \ddot{\psi} + G_{33i} \ddot{\theta} + G_{34i} \ddot{\phi} + G_{35i}) \quad (2.82)$$

Los coeficientes de la ecuación (2.82) se encuentran en el Apéndice D. En la Figura 2.23 se muestra la gráfica que describe el comportamiento de la aceleración de los ángulos θ_{13i} del robot Hexa, al recorrer la trayectoria descrita en el apéndice B en un tiempo de 5 segundos.



Figura 2.23 Gráfica de la aceleración de θ_{13i}

2.6.6. Aceleración del Ángulo θ_{12i}

De la ecuación (2.63) se tiene:

$$(\sec \theta_{12i})^2 (c_{21i} - c\theta_{13i}s\theta_{11i}) \dot{\theta}_{12i} + \tan \theta_{12i} (\dot{c}_{21i} - \dot{\theta}_{11i}c\theta_{13i}c\theta_{11i} + \dot{\theta}_{13i}s\theta_{13i}s\theta_{11i}) = \dot{c}_{31i}c\theta_{11i} - \dot{\theta}_{11i}c_{31i}s\theta_{11i}$$

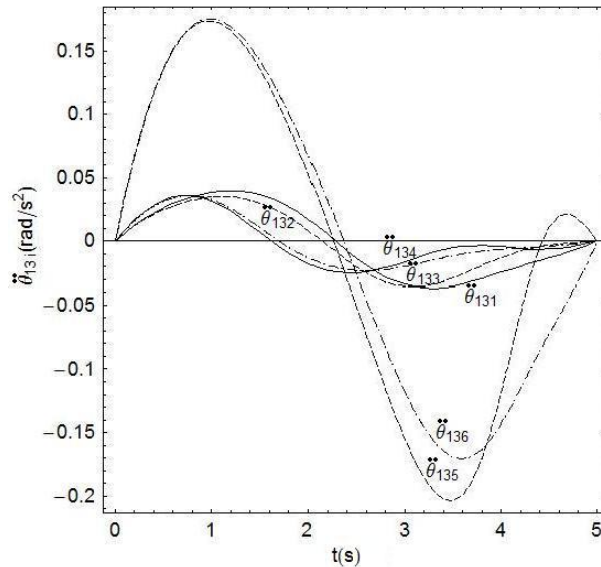
Derivando la expresión anterior:

$$\begin{aligned} & 2s\theta_{11i}\dot{c}_{31i}\dot{\theta}_{11i} + 2\sec^2 \theta_{12i} (c_{21i} - c\theta_{13i}s\theta_{11i}) \dot{\theta}_{12i}^2 \tan \theta_{12i} + \\ & 2\dot{\theta}_{12i} \sec^2 \theta_{12i} (\dot{c}_{21i} - \dot{\theta}_{11i}c\theta_{13i}c\theta_{11i} + \dot{\theta}_{13i}s\theta_{13i}s\theta_{11i}) + \\ & c_{31i} (\dot{\theta}_{11i}^2 c\theta_{11i} + \ddot{\theta}_{11i} s\theta_{11i}) + \sec^2 \theta_{12i} (c_{21i} - c\theta_{13i}s\theta_{11i}) \ddot{\theta}_{12i} + \\ & \tan \theta_{12i} (\ddot{c}_{21i} + c\theta_{11i} (2\dot{\theta}_{11i}\dot{\theta}_{13i}s\theta_{13i} - \ddot{\theta}_{11i}c\theta_{13i})) + \\ & s\theta_{11i} (c\theta_{13i} (\dot{\theta}_{11i}^2 + \dot{\theta}_{13i}^2) + \ddot{\theta}_{13i}s\theta_{13i}) = \ddot{c}_{31i}c\theta_{11i} \end{aligned} \quad (2.83)$$

Despejando $\ddot{\theta}_{12i}$ de la ec. (2.83):

$$\begin{aligned} \ddot{\theta}_{12i} = & \left(\frac{1}{c_{21i} - c\theta_{13i}s\theta_{11i}} \right) \left(-(c\theta_{12i})^2 (2\dot{c}_{31i}\dot{\theta}_{11i}s\theta_{11i} + \dot{\theta}_{11i}^2 c\theta_{13i}s\theta_{11i} \tan \theta_{12i} + \right. \\ & 2\dot{c}_{21i}\dot{\theta}_{12i} \sec^2 \theta_{12i} - 2\dot{\theta}_{11i}\dot{\theta}_{12i}c\theta_{11i}c\theta_{13i} \sec^2 \theta_{12i} + \\ & 2\dot{\theta}_{12i}^2 c_{21i} \sec^2 \theta_{12i} \tan \theta_{12i} - 2\dot{\theta}_{12i}^2 c\theta_{13i} \sec^2 \theta_{12i} s\theta_{11i} \tan \theta_{12i} + \\ & 2\dot{\theta}_{11i}\dot{\theta}_{13i}c\theta_{11i}s\theta_{13i} \tan \theta_{12i} + 2\dot{\theta}_{12i}\dot{\theta}_{13i} \sec^2 \theta_{12i} s\theta_{11i}s\theta_{13i} + \\ & \dot{\theta}_{13i}^2 c\theta_{13i}s\theta_{11i} \tan \theta_{12i} + \ddot{c}_{21i} \tan \theta_{12i} - \ddot{c}_{31i}c\theta_{11i} - \\ & \left. \ddot{\theta}_{11i}c\theta_{11i}c\theta_{13i} \tan \theta_{12i} + c_{31i} (\dot{\theta}_{11i}^2 c\theta_{11i} + \ddot{\theta}_{11i}s\theta_{11i}) + \ddot{\theta}_{13i}s\theta_{11i}s\theta_{13i} \tan \theta_{12i} \right) \end{aligned} \quad (2.84)$$



Figura 2.24 Gráfica de la aceleración de θ_{12i}

Donde c_{21i} , c_{31i} , \dot{c}_{21i} , \dot{c}_{31i} se encuentran en los análisis de posición y velocidad, además derivando dos veces las ecuaciones (2.33) y (2.36) para obtener $(\ddot{c}_{21i}, \ddot{c}_{31i})$, sustituirlas en (2.84) y simplificando se tiene:

$$\ddot{\theta}_{12i} = \frac{1}{V_{45i}} \left(G_{36i} \ddot{x}_p + G_{37i} \ddot{y}_p + G_{38i} \ddot{z}_p + G_{39i} \ddot{\psi} + G_{40i} \ddot{\theta} + G_{41i} \ddot{\phi} + G_{42i} \right) \quad (2.85)$$

Los coeficientes de la ecuación (2.85) se encuentran en el Apéndice D. En la Figura 2.24 se muestra la gráfica que describe el comportamiento de la aceleración de los ángulos θ_{12i} del robot Hexa, al recorrer la trayectoria descrita en el apéndice B en un tiempo de 5 segundos.

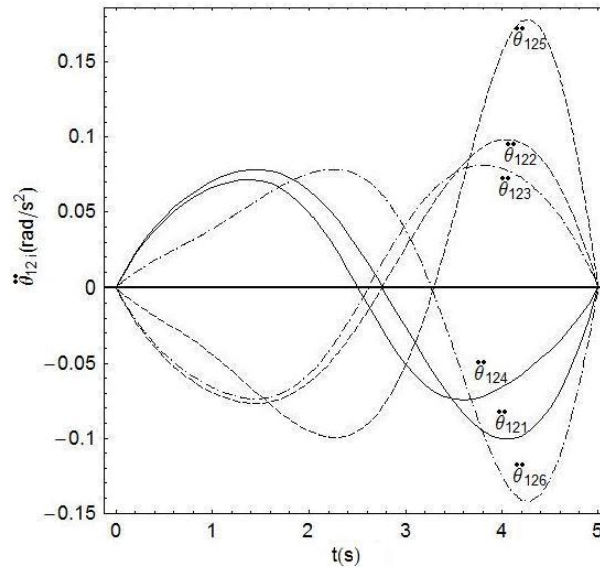
2.7. Análisis de Singularidades

El análisis de singularidades de los robots paralelos se realiza con la ayuda de las matrices Jacobianas de cinemática directa e inversa, en este caso solo se hará uso de la matriz Jacobiana de cinemática inversa. Se obtendrá el determinante de dicha matriz para posteriormente obtener las raíces del mismo. Por último las raíces nos proporcionarán información de las singularidades del robot, es decir, las posiciones que no puede alcanzar el robot. En esta sección se hará un análisis vectorial de posición con el fin de obtener las matrices Jacobianas mencionadas anteriormente.

2.7.1. Análisis Vectorial de Posición Lineal

A partir de la ecuación (2.2), que es la ecuación de posición lineal, se tiene:

$$\mathbf{r}_{1i}^0 + \mathbf{r}_{4i}^0 + \mathbf{r}_{6i}^0 + \mathbf{r}_{9i}^0 = \mathbf{r}_p^0 + \mathbf{r}_{15i}^0 + \mathbf{r}_{13i}^0$$

Donde cada componente es:

$$\begin{aligned} \mathbf{r}_{1i}^0 &= x_{2i} \mathbf{i}_{1i}^0 & \mathbf{r}_{4i}^0 &= x_{5i} \mathbf{i}_{4i}^0 \\ \mathbf{r}_{6i}^0 &= x_{7i} \mathbf{i}_{6i}^0 & \mathbf{r}_{9i}^0 &= x_{10i} \mathbf{i}_{9i}^0 \\ \mathbf{r}_{13i}^0 &= -x_{14i} \mathbf{i}_{14i}^0 & \mathbf{r}_{15i}^0 &= -x_{16i} \mathbf{i}_{16i}^0 \\ \mathbf{r}_p^0 &= x_p \mathbf{i}_0^0 + y_p \mathbf{j}_0^0 + z_p \mathbf{k}_0^0 \end{aligned}$$

Los vectores unitarios están asociados a las bases generadas en la sección 2.4, de tal modo que cada una de las bases se proyecta en la base inercial $(\mathbf{i}_0^0, \mathbf{j}_0^0, \mathbf{k}_0^0)$, como sigue:

Los vectores unitarios $(\mathbf{i}_{1i}^0, \mathbf{j}_{1i}^0, \mathbf{k}_{1i}^0)$ son:

$$\begin{aligned} \mathbf{i}_{1i}^0 &= c\delta_{1i} \mathbf{i}_0^0 + s\delta_{1i} \mathbf{j}_0^0 + 0\mathbf{k}_0^0 \\ \mathbf{j}_{1i}^0 &= -s\delta_{1i} \mathbf{i}_0^0 + c\delta_{1i} \mathbf{j}_0^0 + 0\mathbf{k}_0^0 \\ \mathbf{k}_{1i}^0 &= \mathbf{k}_0^0 \end{aligned}$$

Los vectores unitarios $(\mathbf{i}_{2i}^0, \mathbf{j}_{2i}^0, \mathbf{k}_{2i}^0)$ son:

$$\begin{aligned} \mathbf{i}_{2i}^0 &= \mathbf{i}_{1i}^0 \\ \mathbf{j}_{2i}^0 &= \mathbf{j}_{1i}^0 \\ \mathbf{k}_{2i}^0 &= \mathbf{k}_{1i}^0 \end{aligned}$$

Los vectores unitarios $(\mathbf{i}_{3i}^0, \mathbf{j}_{3i}^0, \mathbf{k}_{3i}^0)$ son:

$$\begin{aligned} \mathbf{i}_{3i}^0 &= c\delta_{3i} \mathbf{i}_{2i}^0 + s\delta_{3i} \mathbf{j}_{2i}^0 + 0\mathbf{k}_{2i}^0 \\ \mathbf{j}_{3i}^0 &= -s\delta_{3i} \mathbf{i}_{2i}^0 + c\delta_{3i} \mathbf{j}_{2i}^0 + 0\mathbf{k}_{2i}^0 \\ \mathbf{k}_{3i}^0 &= \mathbf{k}_{2i}^0 \end{aligned}$$

Los vectores unitarios $(\mathbf{i}_{4i}^0, \mathbf{j}_{4i}^0, \mathbf{k}_{4i}^0)$ son:

$$\begin{aligned}\mathbf{i}_{4i}^0 &= c\theta_{4i}\mathbf{i}_{3i}^0 + 0\mathbf{j}_{3i}^0 - s\theta_{4i}\mathbf{k}_{3i}^0 \\ \mathbf{j}_{4i}^0 &= \mathbf{j}_{3i}^0 \\ \mathbf{k}_{4i}^0 &= s\theta_{4i}\mathbf{i}_{3i}^0 + 0\mathbf{j}_{3i}^0 + c\theta_{4i}\mathbf{k}_{3i}^0\end{aligned}$$

Los vectores unitarios $(\mathbf{i}_{5i}^0, \mathbf{j}_{5i}^0, \mathbf{k}_{5i}^0)$ son:

$$\begin{aligned}\mathbf{i}_{5i}^0 &= \mathbf{i}_{4i}^0 \\ \mathbf{j}_{5i}^0 &= \mathbf{j}_{4i}^0 \\ \mathbf{k}_{5i}^0 &= \mathbf{k}_{4i}^0\end{aligned}$$

Los vectores unitarios $(\mathbf{i}_{6i}^0, \mathbf{j}_{6i}^0, \mathbf{k}_{6i}^0)$ son:

$$\begin{aligned}\mathbf{i}_{6i}^0 &= c\delta_{6i}\mathbf{i}_{5i}^0 + s\delta_{6i}\mathbf{j}_{5i}^0 + 0\mathbf{k}_{5i}^0 \\ \mathbf{j}_{6i}^0 &= -s\delta_{6i}\mathbf{i}_{5i}^0 + c\delta_{6i}\mathbf{j}_{5i}^0 + 0\mathbf{k}_{5i}^0 \\ \mathbf{k}_{6i}^0 &= \mathbf{k}_{5i}^0\end{aligned}$$

Los vectores unitarios $(\mathbf{i}_{7i}^0, \mathbf{j}_{7i}^0, \mathbf{k}_{7i}^0)$ son:

$$\begin{aligned}\mathbf{i}_{7i}^0 &= \mathbf{i}_{6i}^0 \\ \mathbf{j}_{7i}^0 &= \mathbf{j}_{6i}^0 \\ \mathbf{k}_{7i}^0 &= \mathbf{k}_{6i}^0\end{aligned}$$

Los vectores unitarios $(\mathbf{i}_{8i}^0, \mathbf{j}_{8i}^0, \mathbf{k}_{8i}^0)$ son:

$$\begin{aligned}\mathbf{i}_{8i}^0 &= \mathbf{i}_{7i}^0 \\ \mathbf{j}_{8i}^0 &= 0\mathbf{i}_{7i}^0 + c\theta_{8i}\mathbf{j}_{7i}^0 + s\theta_{8i}\mathbf{k}_{7i}^0 \\ \mathbf{k}_{8i}^0 &= 0\mathbf{i}_{7i}^0 - s\theta_{8i}\mathbf{j}_{7i}^0 + c\theta_{8i}\mathbf{k}_{7i}^0\end{aligned}$$

Los vectores unitarios $(\mathbf{i}_{9i}^0, \mathbf{j}_{9i}^0, \mathbf{k}_{9i}^0)$ son:

$$\begin{aligned}\mathbf{i}_{9i}^0 &= c\theta_{9i}\mathbf{i}_{8i}^0 + 0\mathbf{j}_{8i}^0 - s\theta_{9i}\mathbf{k}_{8i}^0 \\ \mathbf{j}_{9i}^0 &= \mathbf{j}_{8i}^0 \\ \mathbf{k}_{9i}^0 &= s\theta_{9i}\mathbf{i}_{8i}^0 + 0\mathbf{j}_{8i}^0 + c\theta_{9i}\mathbf{k}_{8i}^0\end{aligned}$$

Los vectores unitarios $(\mathbf{i}_{10i}^0, \mathbf{j}_{10i}^0, \mathbf{k}_{10i}^0)$ son:

$$\begin{aligned}\mathbf{i}_{10i}^0 &= \mathbf{i}_{9i}^0 \\ \mathbf{j}_{10i}^0 &= \mathbf{j}_{9i}^0 \\ \mathbf{k}_{10i}^0 &= \mathbf{k}_{9i}^0\end{aligned}$$

Los vectores unitarios $(\mathbf{i}_{16i}^0, \mathbf{j}_{16i}^0, \mathbf{k}_{16i}^0)$ son:

$$\begin{aligned}\mathbf{i}_{16i}^0 &= c\delta_{17i}\mathbf{i}_p^0 - s\delta_{17i}\mathbf{j}_p^0 + 0\mathbf{k}_p^0 \\ \mathbf{j}_{16i}^0 &= s\delta_{17i}\mathbf{i}_p^0 + c\delta_{17i}\mathbf{j}_p^0 + 0\mathbf{k}_p^0 \\ \mathbf{k}_{16i}^0 &= \mathbf{k}_p^0\end{aligned}$$

Donde la base $(\mathbf{i}_{17i}^0, \mathbf{j}_{17i}^0, \mathbf{k}_{17i}^0)$ es igual a la base $(\mathbf{i}_p^0, \mathbf{j}_p^0, \mathbf{k}_p^0)$. Esta última base la podemos expresar mediante 3 ángulos de Euler (ψ, θ, ϕ) , tal como se muestra en la sección 2.4.

Rotando ψ para obtener la base $(\mathbf{i}_{18}^0, \mathbf{j}_{18}^0, \mathbf{k}_{18}^0)$:

$$\begin{aligned}\mathbf{i}_{18}^0 &= c\psi\mathbf{i}_0^0 + s\psi\mathbf{j}_0^0 + 0\mathbf{k}_0^0 \\ \mathbf{j}_{18}^0 &= -s\psi\mathbf{i}_0^0 + c\psi\mathbf{j}_0^0 + 0\mathbf{k}_0^0 \\ \mathbf{k}_{18}^0 &= \mathbf{k}_0^0\end{aligned}$$

Rotando θ para obtener la base $(\mathbf{i}_{19}^0, \mathbf{j}_{19}^0, \mathbf{k}_{19}^0)$:

$$\begin{aligned}\mathbf{i}_{19}^0 &= \mathbf{i}_{18}^0 \\ \mathbf{j}_{19}^0 &= 0\mathbf{i}_{18}^0 + c\theta\mathbf{j}_{18}^0 + s\theta\mathbf{k}_{18}^0 \\ \mathbf{k}_{19}^0 &= 0\mathbf{i}_{18}^0 - s\theta\mathbf{j}_{18}^0 + c\theta\mathbf{k}_{18}^0\end{aligned}$$

Rotando ϕ para obtener la base $(\mathbf{i}_{20}^0, \mathbf{j}_{20}^0, \mathbf{k}_{20}^0)$:

$$\begin{aligned}\mathbf{i}_{20}^0 &= c\phi\mathbf{i}_{19}^0 + s\phi\mathbf{j}_{19}^0 + 0\mathbf{k}_{19}^0 \\ \mathbf{j}_{20}^0 &= -s\phi\mathbf{i}_{19}^0 + c\phi\mathbf{j}_{19}^0 + 0\mathbf{k}_{19}^0 \\ \mathbf{k}_{20}^0 &= \mathbf{k}_{19}^0\end{aligned}$$

Los vectores unitarios $(\mathbf{i}_p^0, \mathbf{j}_p^0, \mathbf{k}_p^0)$ son:

$$\begin{aligned}\mathbf{i}_p^0 &= \mathbf{i}_{20}^0 \\ \mathbf{j}_p^0 &= \mathbf{j}_{20}^0 \\ \mathbf{k}_p^0 &= \mathbf{k}_{20}^0\end{aligned}$$

Los vectores unitarios $(\mathbf{i}_{15i}^0, \mathbf{j}_{15i}^0, \mathbf{k}_{15i}^0)$ son:

$$\begin{aligned}\mathbf{i}_{15i}^0 &= \mathbf{i}_{16i}^0 \\ \mathbf{j}_{15i}^0 &= \mathbf{j}_{16i}^0 \\ \mathbf{k}_{15i}^0 &= \mathbf{k}_{16i}^0\end{aligned}$$

Los vectores unitarios $(\mathbf{i}_{14i}^0, \mathbf{j}_{14i}^0, \mathbf{k}_{14i}^0)$ son:

$$\begin{aligned}\mathbf{i}_{14i}^0 &= c\delta_{15i}\mathbf{i}_{15i}^0 - s\delta_{15i}\mathbf{j}_{15i}^0 + 0\mathbf{k}_{15i}^0 \\ \mathbf{j}_{14i}^0 &= s\delta_{15i}\mathbf{i}_{15i}^0 + c\delta_{15i}\mathbf{j}_{15i}^0 + 0\mathbf{k}_{15i}^0 \\ \mathbf{k}_{14i}^0 &= \mathbf{k}_{15i}^0\end{aligned}$$

2.7.2. Análisis Vectorial de Velocidad Lineal

La ecuación de velocidad lineal se obtiene derivando respecto al tiempo la ec. (2.2):

$$\mathbf{v}_{1i}^0 + \mathbf{v}_{4i}^0 + \mathbf{v}_{6i}^0 + \mathbf{v}_{9i}^0 = \mathbf{v}_p^0 + \mathbf{v}_{15i}^0 + \mathbf{v}_{13i}^0 \quad (2.86)$$

Donde cada elemento es:

$$\begin{aligned}
 \mathbf{v}_{1i}^0 &= 0 \\
 \mathbf{v}_{4i}^0 &= \boldsymbol{\Omega}_{4i}^0 \times \mathbf{r}_{4i}^0 \\
 \mathbf{v}_{6i}^0 &= \boldsymbol{\Omega}_{4i}^0 \times \mathbf{r}_{6i}^0 \\
 \mathbf{v}_{9i}^0 &= \boldsymbol{\Omega}_{9i}^0 \times \mathbf{r}_{9i}^0 \\
 \mathbf{v}_{13i}^0 &= \boldsymbol{\Omega}_p^0 \times \mathbf{r}_{13i}^0 \\
 \mathbf{v}_{15i}^0 &= \boldsymbol{\Omega}_p^0 \times \mathbf{r}_{15i}^0 \\
 \mathbf{v}_p^0 &= \dot{x}_p \mathbf{i}_0^0 + \dot{y}_p \mathbf{j}_0^0 + \dot{z}_p \mathbf{k}_0^0
 \end{aligned} \tag{2.87}$$

2.7.3. Análisis Vectorial de Velocidad Angular

Los vectores de velocidad angular absolutos de las bases son:

$$\begin{aligned}
 \boldsymbol{\Omega}_{4i}^0 &= \boldsymbol{\omega}_{4i}^0 \\
 \boldsymbol{\Omega}_{9i}^0 &= \boldsymbol{\omega}_{4i}^0 + \boldsymbol{\omega}_{8i}^0 + \boldsymbol{\omega}_{9i}^0 \\
 \boldsymbol{\Omega}_p^0 &= \boldsymbol{\omega}_\psi^0 + \boldsymbol{\omega}_\theta^0 + \boldsymbol{\omega}_\phi^0
 \end{aligned} \tag{2.88}$$

Donde cada una de las velocidades angulares es:

$$\begin{aligned}
 \boldsymbol{\omega}_{4i}^0 &= \dot{\theta}_{4i} \mathbf{j}_{4i}^0 & \boldsymbol{\omega}_\psi^0 &= \dot{\psi} \mathbf{k}_0^0 \\
 \boldsymbol{\omega}_{8i}^0 &= \dot{\theta}_{8i} \mathbf{i}_{8i}^0 & \boldsymbol{\omega}_\theta^0 &= \dot{\theta}_{18} \mathbf{i}_{18}^0 \\
 \boldsymbol{\omega}_{9i}^0 &= \dot{\theta}_{9i} \mathbf{j}_{9i}^0 & \boldsymbol{\omega}_\phi^0 &= \dot{\phi} \mathbf{k}_{19}^0
 \end{aligned} \tag{2.89}$$

2.7.4. Matriz Jacobiana de Velocidad para θ_{4i}

A partir de la ec. (2.86):

$$\mathbf{v}_{1i}^0 + \mathbf{v}_{4i}^0 + \mathbf{v}_{6i}^0 + \mathbf{v}_{9i}^0 = \mathbf{v}_p^0 + \mathbf{v}_{15i}^0 + \mathbf{v}_{13i}^0$$

Sustituyendo los elementos de las ecs. (2.87):

$$\boldsymbol{\Omega}_{4i}^0 \times \mathbf{r}_{4i}^0 + \boldsymbol{\Omega}_{4i}^0 \times \mathbf{r}_{6i}^0 + \boldsymbol{\Omega}_{9i}^0 \times \mathbf{r}_{9i}^0 = \mathbf{v}_p^0 + \boldsymbol{\Omega}_p^0 \times \mathbf{r}_{15i}^0 + \boldsymbol{\Omega}_p^0 \times \mathbf{r}_{13i}^0$$

Agrupando:

$$\boldsymbol{\Omega}_{4i}^0 \times (\mathbf{r}_{4i}^0 + \mathbf{r}_{6i}^0) + \boldsymbol{\Omega}_{9i}^0 \times \mathbf{r}_{9i}^0 = \mathbf{v}_p^0 + \boldsymbol{\Omega}_p^0 \times (\mathbf{r}_{15i}^0 + \mathbf{r}_{13i}^0)$$

Con el fin de eliminar los términos $\dot{\theta}_{8i}, \dot{\theta}_{9i}$ que aparecen en $\boldsymbol{\Omega}_{9i}^0$ y dejar la ec. anterior solo en términos de $\dot{\theta}_{4i}$, se hará el producto punto por \mathbf{r}_{9i}^0 en ambos lados de la ecuación (Tsai, 1999):

$$\begin{aligned}
 \mathbf{r}_{9i}^0 \cdot (\boldsymbol{\Omega}_{4i}^0 \times (\mathbf{r}_{4i}^0 + \mathbf{r}_{6i}^0)) + \mathbf{r}_{9i}^0 \cdot (\boldsymbol{\Omega}_{9i}^0 \times \mathbf{r}_{9i}^0) &= \mathbf{r}_{9i}^0 \cdot \mathbf{v}_p^0 + \mathbf{r}_{9i}^0 \cdot (\boldsymbol{\Omega}_p^0 \times (\mathbf{r}_{15i}^0 + \mathbf{r}_{13i}^0)) \\
 \mathbf{r}_{9i}^0 \cdot (\boldsymbol{\Omega}_{4i}^0 \times (\mathbf{r}_{4i}^0 + \mathbf{r}_{6i}^0)) &= \mathbf{r}_{9i}^0 \cdot \mathbf{v}_p^0 + \mathbf{r}_{9i}^0 \cdot (\boldsymbol{\Omega}_p^0 \times (\mathbf{r}_{15i}^0 + \mathbf{r}_{13i}^0))
 \end{aligned}$$

Ahora sustituyendo los elementos de las ecs. (2.88) y (2.89):

$$\mathbf{r}_{9i}^0 \cdot (\dot{\theta}_{4i} \mathbf{j}_{4i}^0 \times (\mathbf{r}_{4i}^0 + \mathbf{r}_{6i}^0)) = \mathbf{r}_{9i}^0 \cdot \mathbf{v}_p^0 + \mathbf{r}_{9i}^0 \cdot ((\dot{\psi} \mathbf{k}_0^0 + \dot{\theta}_{18} \mathbf{i}_{18}^0 + \dot{\phi} \mathbf{k}_{19}^0) \times (\mathbf{r}_{13i}^0 + \mathbf{r}_{15i}^0))$$

Factorizando:

$$\dot{\theta}_{4i} \mathbf{j}_{4i}^0 \cdot \left((\mathbf{r}_{4i}^0 + \mathbf{r}_{6i}^0) \times \mathbf{r}_{9i}^0 \right) = \mathbf{r}_{9i}^0 \cdot \mathbf{v}_p^0 + \dot{\psi} \mathbf{k}_0^0 \cdot \left((\mathbf{r}_{13i}^0 + \mathbf{r}_{15i}^0) \times \mathbf{r}_{9i}^0 \right) + \dot{\theta}_{18}^0 \cdot \left((\mathbf{r}_{13i}^0 + \mathbf{r}_{15i}^0) \times \mathbf{r}_{9i}^0 \right) + \dot{\phi} \mathbf{k}_{19}^0 \cdot \left((\mathbf{r}_{13i}^0 + \mathbf{r}_{15i}^0) \times \mathbf{r}_{9i}^0 \right) \quad (2.90)$$

Renombrando en la ec. (2.90):

$$\dot{\theta}_{4i} \mathbf{j}_{4i}^0 \cdot \mathbf{u}_i = \mathbf{r}_{9i}^0 \cdot \mathbf{v}_p^0 + \dot{\psi} \mathbf{k}_0^0 \cdot \mathbf{v}_i + \dot{\theta}_{18}^0 \cdot \mathbf{v}_i + \dot{\phi} \mathbf{k}_{19}^0 \cdot \mathbf{v}_i \quad (2.91)$$

Donde:

$$\begin{aligned} \mathbf{u}_i &= (\mathbf{r}_{4i}^0 + \mathbf{r}_{6i}^0) \times \mathbf{r}_{9i}^0 \\ \mathbf{v}_i &= (\mathbf{r}_{13i}^0 + \mathbf{r}_{15i}^0) \times \mathbf{r}_{9i}^0 \end{aligned} \quad (2.92)$$

Escribiendo la ec. (2.91) seis veces, una para cada $i=1, 2, 3, 4, 5, 6$, obtenemos seis ecuaciones escalares, las cuales se pueden ordenar de la sig. forma:

$$\mathbf{J}_q \dot{\mathbf{q}} = \mathbf{J}_\theta \dot{\Theta} \quad (2.93)$$

Siendo $\mathbf{J}_q, \mathbf{J}_\theta$ las matrices Jacobianas de cinemática directa e inversa respectivamente, además:

$$\begin{aligned} \dot{\mathbf{q}} &= [\mathbf{v}_p^0, \dot{\psi}, \dot{\theta}, \dot{\phi}]^T \\ \dot{\Theta} &= [\dot{\theta}_{41}, \dot{\theta}_{42}, \dot{\theta}_{43}, \dot{\theta}_{44}, \dot{\theta}_{45}, \dot{\theta}_{46}]^T \end{aligned}$$

Finalmente de forma matricial se tiene:

$$\mathbf{J}_q \dot{\mathbf{q}} = \begin{bmatrix} \mathbf{r}_{91}^0 & \mathbf{k}_0^0 \cdot \mathbf{v}_1 & \mathbf{i}_{18}^0 \cdot \mathbf{v}_1 & \mathbf{k}_{19}^0 \cdot \mathbf{v}_1 \\ \mathbf{r}_{92}^0 & \mathbf{k}_0^0 \cdot \mathbf{v}_2 & \mathbf{i}_{18}^0 \cdot \mathbf{v}_2 & \mathbf{k}_{19}^0 \cdot \mathbf{v}_2 \\ \mathbf{r}_{93}^0 & \mathbf{k}_0^0 \cdot \mathbf{v}_3 & \mathbf{i}_{18}^0 \cdot \mathbf{v}_3 & \mathbf{k}_{19}^0 \cdot \mathbf{v}_3 \\ \mathbf{r}_{94}^0 & \mathbf{k}_0^0 \cdot \mathbf{v}_4 & \mathbf{i}_{18}^0 \cdot \mathbf{v}_4 & \mathbf{k}_{19}^0 \cdot \mathbf{v}_4 \\ \mathbf{r}_{95}^0 & \mathbf{k}_0^0 \cdot \mathbf{v}_5 & \mathbf{i}_{18}^0 \cdot \mathbf{v}_5 & \mathbf{k}_{19}^0 \cdot \mathbf{v}_5 \\ \mathbf{r}_{96}^0 & \mathbf{k}_0^0 \cdot \mathbf{v}_6 & \mathbf{i}_{18}^0 \cdot \mathbf{v}_6 & \mathbf{k}_{19}^0 \cdot \mathbf{v}_6 \end{bmatrix} \begin{bmatrix} \mathbf{v}_p^0 \\ \dot{\psi} \\ \dot{\theta} \\ \dot{\phi} \end{bmatrix}$$

$$\mathbf{J}_\theta \dot{\Theta} = \begin{bmatrix} \mathbf{j}_{41}^0 \cdot \mathbf{u}_1 & 0 & 0 & 0 & 0 & 0 \\ 0 & \mathbf{j}_{42}^0 \cdot \mathbf{u}_2 & 0 & 0 & 0 & 0 \\ 0 & 0 & \mathbf{j}_{43}^0 \cdot \mathbf{u}_3 & 0 & 0 & 0 \\ 0 & 0 & 0 & \mathbf{j}_{44}^0 \cdot \mathbf{u}_4 & 0 & 0 \\ 0 & 0 & 0 & 0 & \mathbf{j}_{45}^0 \cdot \mathbf{u}_5 & 0 \\ 0 & 0 & 0 & 0 & 0 & \mathbf{j}_{46}^0 \cdot \mathbf{u}_6 \end{bmatrix} \begin{bmatrix} \dot{\theta}_{41} \\ \dot{\theta}_{42} \\ \dot{\theta}_{43} \\ \dot{\theta}_{44} \\ \dot{\theta}_{45} \\ \dot{\theta}_{46} \end{bmatrix}$$

2.7.4.1. Análisis de Singularidades de Cinemática Inversa

En este tipo de singularidades se dice que el robot pierde un grado de libertad (Tsai, 1999), lo cual produce que el robot tienda a trabarse y por consecuencia se presente un incremento en la corriente requerida por el actuador, lo cual es indeseable. Por tal motivo, las posiciones singulares se deben evitar al máximo. Ahora, obteniendo el determinante de la matriz Jacobiana de cinemática inversa:

$$\begin{aligned} \det[\mathbf{J}_\theta] &= (x_{101} (x_{51} + x_{71} c \delta_{61}) c \theta_{81} s \theta_{91}) (x_{102} (x_{52} + x_{72} c \delta_{62}) c \theta_{82} s \theta_{92}) (x_{103} (x_{53} + x_{73} c \delta_{63}) c \theta_{83} s \theta_{93}) \\ &\quad (x_{104} (x_{54} + x_{74} c \delta_{64}) c \theta_{84} s \theta_{94}) (x_{105} (x_{55} + x_{75} c \delta_{65}) c \theta_{85} s \theta_{95}) (x_{106} (x_{56} + x_{76} c \delta_{66}) c \theta_{86} s \theta_{96}) \end{aligned}$$

Para obtener las raíces de $\det[\mathbf{J}_\theta]$ nos podemos dar cuenta que, por restricciones físicas del robot, los términos $x_{10i} (x_{5i} + x_{7i} c\delta_{6i})$ jamás podrán ser cero, por lo que los únicos términos que pueden ser cero son $c\theta_{8i}, s\theta_{9i}$. De esta forma igualando a cero cada una de las expresiones anteriores se tiene que:

$$\begin{aligned} c\theta_{8i} &= 0 && \text{cuando } \theta_{8i} = 90^\circ, 270^\circ, 450^\circ, \dots \\ s\theta_{9i} &= 0 && \text{cuando } \theta_{9i} = 0^\circ, 180^\circ, 360^\circ, \dots \end{aligned}$$

Lo anterior permite darnos cuenta que, si en cualquier cadena, al menos uno de los dos ángulos anteriores alcanza una de los valores mencionados, el robot se encontrará en una posición singular. Se puede ver gráficamente en la Figura 2.2 y Figura 2.6 que esto sucederá cuando los vectores \mathbf{r}_{6i} y \mathbf{r}_{9i} se alineen.

2.7.4.2. Análisis de Singularidades de Cinemática Directa

En este tipo de singularidades se dice que el robot gana un grado de libertad (Tsai, 1999), lo cual produce que el robot pierda rigidez y por consecuencia el mecanismo reduzca su capacidad de carga. Debido a que el cálculo del determinante es complicado, se determinará por inspección solo una de las singularidades de cinemática directa.

Del algebra lineal se sabe que con al menos dos columnas o renglones iguales de una matriz su determinante es cero. Por inspección se puede ver que las columnas 4 y 6 de la matriz \mathbf{J}_q son iguales cuando \mathbf{k}_0^0 y \mathbf{k}_{19}^0 son iguales, se puede ver de las definiciones de \mathbf{k}_0^0 y \mathbf{k}_{19}^0 (Anteriormente presentadas), que esto se cumple cuando θ es igual a cero. Por lo tanto, el robot estará en una posición singular de cinemática directa en cualquier momento que el ángulo $\theta = 0$.

2.7.5. Matriz Jacobiana de Velocidad para θ_{9i}

A partir de la ec. (2.86):

$$\mathbf{v}_{1i}^0 + \mathbf{v}_{4i}^0 + \mathbf{v}_{6i}^0 + \mathbf{v}_{9i}^0 = \mathbf{v}_p^0 + \mathbf{v}_{15i}^0 + \mathbf{v}_{13i}^0$$

Sustituyendo los elementos de las ecs. (2.87):

$$\boldsymbol{\Omega}_{4i}^0 \times \mathbf{r}_{4i}^0 + \boldsymbol{\Omega}_{4i}^0 \times \mathbf{r}_{6i}^0 + \boldsymbol{\Omega}_{9i}^0 \times \mathbf{r}_{9i}^0 = \mathbf{v}_p^0 + \boldsymbol{\Omega}_p^0 \times \mathbf{r}_{15i}^0 + \boldsymbol{\Omega}_p^0 \times \mathbf{r}_{13i}^0$$

Agrupando:

$$\boldsymbol{\Omega}_{4i}^0 \times (\mathbf{r}_{4i}^0 + \mathbf{r}_{6i}^0) + \boldsymbol{\Omega}_{9i}^0 \times \mathbf{r}_{9i}^0 = \mathbf{v}_p^0 + \boldsymbol{\Omega}_p^0 \times (\mathbf{r}_{15i}^0 + \mathbf{r}_{13i}^0)$$

Con el fin de eliminar los términos $\dot{\theta}_{4i}, \dot{\theta}_{8i}$ que aparecen en $\boldsymbol{\Omega}_{4i}^0$ y $\boldsymbol{\Omega}_{9i}^0$ y dejar la ec. anterior solo en términos de $\dot{\theta}_{9i}$, se hará el producto punto por \mathbf{j}_{4i}^{4i} en ambos lados de la ecuación (Tsai, 1999):

$$\mathbf{j}_{4i}^0 \cdot (\boldsymbol{\Omega}_{4i}^0 \times (\mathbf{r}_{4i}^0 + \mathbf{r}_{6i}^0)) + \mathbf{j}_{4i}^0 \cdot (\boldsymbol{\Omega}_{9i}^0 \times \mathbf{r}_{9i}^0) = \mathbf{j}_{4i}^0 \cdot \mathbf{v}_p^0 + \mathbf{j}_{4i}^0 \cdot (\boldsymbol{\Omega}_p^0 \times (\mathbf{r}_{15i}^0 + \mathbf{r}_{13i}^0))$$

Ahora sustituyendo los elementos de las ecs. (2.88) y (2.89):

$$\begin{aligned} \mathbf{j}_{4i}^0 \cdot (\dot{\theta}_{4i} \mathbf{j}_{4i}^0 \times (\mathbf{r}_{4i}^0 + \mathbf{r}_{6i}^0)) + \mathbf{j}_{4i}^0 \cdot ((\dot{\theta}_{4i} \mathbf{j}_{4i}^0 + \dot{\theta}_{8i} \mathbf{i}_{8i}^0 + \dot{\theta}_{9i} \mathbf{j}_{9i}^0) \times \mathbf{r}_{9i}^0) &= \mathbf{j}_{4i}^0 \cdot \mathbf{v}_p^0 + \\ \mathbf{j}_{4i}^0 \cdot ((\dot{\psi} \mathbf{k}_0^0 + \dot{\theta}_{18}^0 + \dot{\phi} \mathbf{k}_{19}^0) \times (\mathbf{r}_{13i}^0 + \mathbf{r}_{15i}^0)) & \\ \mathbf{j}_{4i}^0 \cdot (\dot{\theta}_{9i} \mathbf{j}_{9i}^0 \times \mathbf{r}_{9i}^0) &= \mathbf{j}_{4i}^0 \cdot \mathbf{v}_p^0 + \mathbf{j}_{4i}^0 \cdot ((\dot{\psi} \mathbf{k}_0^0 + \dot{\theta}_{18}^0 + \dot{\phi} \mathbf{k}_{19}^0) \times (\mathbf{r}_{13i}^0 + \mathbf{r}_{15i}^0)) \end{aligned}$$

Factorizando:

$$\begin{aligned}
 \mathbf{j}_{4i}^0 \cdot (\dot{\theta}_{9i} \mathbf{j}_{9i}^0 \times \mathbf{r}_{9i}^0) &= \mathbf{j}_{4i}^0 \cdot \mathbf{v}_p^0 + \mathbf{j}_{4i}^0 \cdot \left((\dot{\psi} \mathbf{k}_0^0 + \dot{\theta}_{18}^0 + \dot{\phi} \mathbf{k}_{19}^0) \times (\mathbf{r}_{13i}^0 + \mathbf{r}_{15i}^0) \right) \\
 \dot{\theta}_{9i} \mathbf{j}_{9i}^0 \cdot (\mathbf{r}_{9i}^0 \times \mathbf{j}_{4i}^0) &= \mathbf{j}_{4i}^0 \cdot \mathbf{v}_p^0 + \dot{\psi} \mathbf{k}_0^0 \cdot \left((\mathbf{r}_{13i}^0 + \mathbf{r}_{15i}^0) \times \mathbf{j}_{4i}^0 \right) + \\
 &\quad \dot{\theta}_{18}^0 \cdot \left((\mathbf{r}_{13i}^0 + \mathbf{r}_{15i}^0) \times \mathbf{j}_{4i}^0 \right) + \\
 &\quad \dot{\phi} \mathbf{k}_{19}^0 \cdot \left((\mathbf{r}_{13i}^0 + \mathbf{r}_{15i}^0) \times \mathbf{j}_{4i}^0 \right)
 \end{aligned} \tag{2.94}$$

Renombrando en la ec. (2.94):

$$\dot{\theta}_{9i} \mathbf{j}_{9i}^0 \cdot \mathbf{u}'_i = \mathbf{j}_{4i}^0 \cdot \mathbf{v}_p^0 + \dot{\psi} \mathbf{k}_0^0 \cdot \mathbf{v}'_i + \dot{\theta}_{18}^0 \cdot \mathbf{v}'_i + \dot{\phi} \mathbf{k}_{19}^0 \cdot \mathbf{v}'_i \tag{2.95}$$

Donde:

$$\begin{aligned}
 \mathbf{u}'_i &= \mathbf{r}_{9i}^0 \times \mathbf{j}_{4i}^0 \\
 \mathbf{v}'_i &= (\mathbf{r}_{13i}^0 + \mathbf{r}_{15i}^0) \times \mathbf{j}_{4i}^0
 \end{aligned}$$

Escribiendo la ec. (2.95) seis veces, una para cada $i=1, 2, 3, 4, 5, 6$, obtenemos seis ecuaciones escalares, las cuales se pueden ordenar de la sig. forma:

$$\mathbf{J}'_q \dot{\mathbf{q}}' = \mathbf{J}'_\theta \dot{\Theta}' \tag{2.96}$$

Siendo $\mathbf{J}_q, \mathbf{J}_\theta$ las matrices Jacobianas de cinemática directa e inversa respectivamente, además:

$$\begin{aligned}
 \dot{\mathbf{q}}' &= [\mathbf{v}_p^0, \dot{\psi}, \dot{\theta}, \dot{\phi}]^T \\
 \dot{\Theta}' &= [\dot{\theta}_{91}, \dot{\theta}_{92}, \dot{\theta}_{93}, \dot{\theta}_{94}, \dot{\theta}_{95}, \dot{\theta}_{96}]^T
 \end{aligned}$$

Finalmente de forma matricial se tiene:

$$\mathbf{J}'_q \dot{\mathbf{q}}' = \begin{bmatrix} \mathbf{j}_{41}^0 & \mathbf{k}_0^0 \cdot \mathbf{v}'_1 & \mathbf{i}_{18}^0 \cdot \mathbf{v}'_1 & \mathbf{k}_{19}^0 \cdot \mathbf{v}'_1 \\ \mathbf{j}_{42}^0 & \mathbf{k}_0^0 \cdot \mathbf{v}'_2 & \mathbf{i}_{18}^0 \cdot \mathbf{v}'_2 & \mathbf{k}_{19}^0 \cdot \mathbf{v}'_2 \\ \mathbf{j}_{43}^0 & \mathbf{k}_0^0 \cdot \mathbf{v}'_3 & \mathbf{i}_{18}^0 \cdot \mathbf{v}'_3 & \mathbf{k}_{19}^0 \cdot \mathbf{v}'_3 \\ \mathbf{j}_{44}^0 & \mathbf{k}_0^0 \cdot \mathbf{v}'_4 & \mathbf{i}_{18}^0 \cdot \mathbf{v}'_4 & \mathbf{k}_{19}^0 \cdot \mathbf{v}'_4 \\ \mathbf{j}_{45}^0 & \mathbf{k}_0^0 \cdot \mathbf{v}'_5 & \mathbf{i}_{18}^0 \cdot \mathbf{v}'_5 & \mathbf{k}_{19}^0 \cdot \mathbf{v}'_5 \\ \mathbf{j}_{46}^0 & \mathbf{k}_0^0 \cdot \mathbf{v}'_6 & \mathbf{i}_{18}^0 \cdot \mathbf{v}'_6 & \mathbf{k}_{19}^0 \cdot \mathbf{v}'_6 \end{bmatrix} \begin{bmatrix} \mathbf{v}_p^0 \\ \dot{\psi} \\ \dot{\theta} \\ \dot{\phi} \end{bmatrix}$$

$$\mathbf{J}'_\theta \dot{\Theta}' = \begin{bmatrix} \mathbf{j}_{91}^0 \cdot \mathbf{u}'_1 & 0 & 0 & 0 & 0 & 0 \\ 0 & \mathbf{j}_{92}^0 \cdot \mathbf{u}'_2 & 0 & 0 & 0 & 0 \\ 0 & 0 & \mathbf{j}_{93}^0 \cdot \mathbf{u}'_3 & 0 & 0 & 0 \\ 0 & 0 & 0 & \mathbf{j}_{94}^0 \cdot \mathbf{u}'_4 & 0 & 0 \\ 0 & 0 & 0 & 0 & \mathbf{j}_{95}^0 \cdot \mathbf{u}'_5 & 0 \\ 0 & 0 & 0 & 0 & 0 & \mathbf{j}_{96}^0 \cdot \mathbf{u}'_6 \end{bmatrix} \begin{bmatrix} \dot{\theta}_{91} \\ \dot{\theta}_{92} \\ \dot{\theta}_{93} \\ \dot{\theta}_{94} \\ \dot{\theta}_{95} \\ \dot{\theta}_{96} \end{bmatrix}$$

2.7.5.1. Análisis de Singularidades de Cinemática Inversa

La importancia de tener en cuenta las posiciones singulares se comentó anteriormente, por tal motivo se procederá a encontrar dichas posiciones. Ahora, obteniendo el determinante de la matriz Jacobiana de cinemática inversa:

$$\det[\mathbf{J}'_{\theta}] = x_{101} (c\delta_{61}c\theta_{91}s\theta_{81} - s\delta_{61}s\theta_{91}) x_{102} (c\delta_{62}c\theta_{92}s\theta_{81} - s\delta_{62}s\theta_{92}) x_{103} (c\delta_{63}c\theta_{93}s\theta_{81} - s\delta_{63}s\theta_{93}) \\ x_{104} (c\delta_{64}c\theta_{94}s\theta_{81} - s\delta_{64}s\theta_{94}) x_{105} (c\delta_{65}c\theta_{95}s\theta_{81} - s\delta_{65}s\theta_{95}) x_{106} (c\delta_{66}c\theta_{96}s\theta_{81} - s\delta_{66}s\theta_{96})$$

Para obtener las raíces de $\det[\mathbf{J}'_{\theta}]$ nos podemos dar cuenta que, por restricciones físicas del robot, los términos $c\delta_{6i}c\theta_{9i}s\theta_{8i}$ será siempre cero debido a que δ_{6i} solo toma los valores de 90° y 270° , de esta forma los términos en los que nos enfocaremos son $s\delta_{6i}s\theta_{9i}$. De esta forma, igualando a cero cada una de las expresiones anteriores se tiene que:

$$s\theta_{9i} = 0 \quad \text{cuando } \theta_{9i} = 0^\circ, 180^\circ, 360^\circ, \dots$$

Lo anterior permite darnos cuenta que, si en cualquier cadena, el ángulo θ_{9i} alcanza uno de los valores mencionados, el robot se encontrará en una posición singular. Cabe mencionar que se obtuvo este mismo resultado en el análisis de singularidades de cinemática inversa del ángulo θ_{4i} .

2.7.5.2. Análisis de Singularidades de Cinemática Directa

Al igual que en el análisis de cinemática directa del ángulo θ_{4i} se presenta el mismo caso con las columnas 4 y 6 de la matriz \mathbf{J}'_q . Por tal motivo, se tiene que el robot estará en una posición singular de cinemática directa en cualquier momento que el ángulo $\theta = 0$. Por otro lado, el tercer término del vector \mathbf{j}_{4i}^0 es siempre cero, tal como se muestra en su definición $\mathbf{j}_{4i}^0 = [-c\delta_{3i}s\delta_{1i} - c\delta_{1i}s\delta_{3i}, c\delta_{1i}c\delta_{3i} - s\delta_{1i}s\delta_{3i}, 0]$. Finalmente, se tiene que el determinante de la matriz \mathbf{J}'_q es siempre cero al tener una columna de ceros, esto nos indica que si se quisiera hacer el ángulo θ_{9i} el ángulo actuado, no se tendría rigidez en el robot y no podrían alcanzarse todas las posiciones deseadas.

Capítulo 3

Análisis Dinámico Formulación Newton-Euler

3.1. Introducción

En este capítulo se presenta la formulación Newton-Euler para el análisis dinámico del robot manipulador Hexa. Dicha formulación incorpora todas las fuerzas actuando sobre los eslabones. Por lo tanto, las ecuaciones dinámicas resultantes incluyen: las fuerzas de restricción entre dos eslabones adyacentes; las fuerzas activas, como son el peso y los torques debidos a los actuadores y las fuerzas inerciales, que sirven para seleccionar los motores. Las fuerzas de restricción son útiles para el dimensionamiento de eslabones y selección de elementos mecánicos, tales como: rodamientos, pernos, tornillos, etc; durante la etapa de diseño.

El método consiste en el cálculo adelantado de las velocidades y aceleraciones de cada eslabón, seguido por el cálculo reiterativo de las fuerzas y momentos de cada junta. Para el desarrollo de este análisis se emplean matrices de rotación básicas que nos permiten representar la rotación de un cuerpo en el espacio. Ya que la rotación es un giro en el espacio de tres grados de libertad, un conjunto de tres parámetros independientes son suficientes para describir la orientación de un cuerpo en el espacio (Flores, 2006).

Al igual que en la análisis cinemático, se realizará solo el estudio de una cadena cinemática, debido a la simetría que existe entre ellas.

3.2. Dinámica del Robot Hexa

Para el análisis del robot hexa se toman los siguientes cuerpos:



Figura 3.1. Cuerpos del robot

Las siguientes matrices de rotación, nos representan rotación alrededor de los ejes x, y, z respectivamente:

$$R_{z4}(\theta_x) = \begin{bmatrix} 1 & 0 & 0 \\ 0 & c\theta_x & -s\theta_x \\ 0 & s\theta_x & c\theta_x \end{bmatrix}, \quad R_{z5}(\theta_y) = \begin{bmatrix} c\theta_y & 0 & s\theta_y \\ 0 & 1 & 0 \\ -s\theta_y & 0 & c\theta_y \end{bmatrix}, \quad R_{z6}(\theta_z) = \begin{bmatrix} c\theta_z & -s\theta_z & 0 \\ s\theta_z & c\theta_z & 0 \\ 0 & 0 & 1 \end{bmatrix}$$

Y las matrices antisimétricas, que se utilizan para definir el producto cruz y equivalen a $S = r \times$:

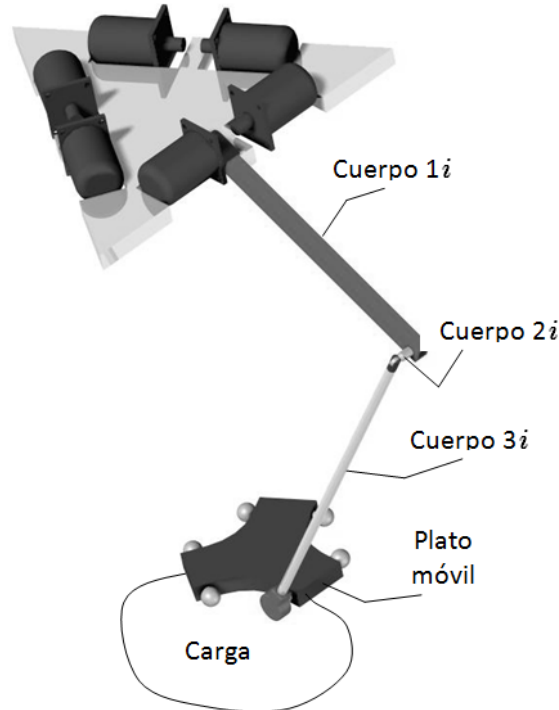
$$S_{z1}(x) = \begin{bmatrix} 0 & 0 & 0 \\ 0 & 0 & -x \\ 0 & x & 0 \end{bmatrix}, \quad S_{z2}(y) = \begin{bmatrix} 0 & 0 & y \\ 0 & 0 & 0 \\ -y & 0 & 0 \end{bmatrix}, \quad S_{z3}(z) = \begin{bmatrix} 0 & -z & 0 \\ z & 0 & 0 \\ 0 & 0 & 0 \end{bmatrix}$$

$$S(x, y, z) = \begin{bmatrix} 0 & -z & y \\ z & 0 & -x \\ -y & x & 0 \end{bmatrix}$$

3.2.1. Análisis del Cuerpo 1_i

El problema general del análisis dinámico formulación Newton-Euler se encuentra detallado en el siguiente trabajo (Flores, 2006), la Figura 3.2 muestra el diagrama de cuerpo libre del cuerpo 1_i:



Figura 3.2. Diagrama de cuerpo libre del cuerpo 1i

3.2.1.1. Ecuaciones Dinámicas

Tomando la suma de fuerzas que actúan en el cuerpo 1_i , tenemos:

$$\mathbf{F}_{1_i}^A + \mathbf{F}_{1_i}^R + \mathbf{F}_{1_i}^I = \mathbf{0} \quad (3.1)$$

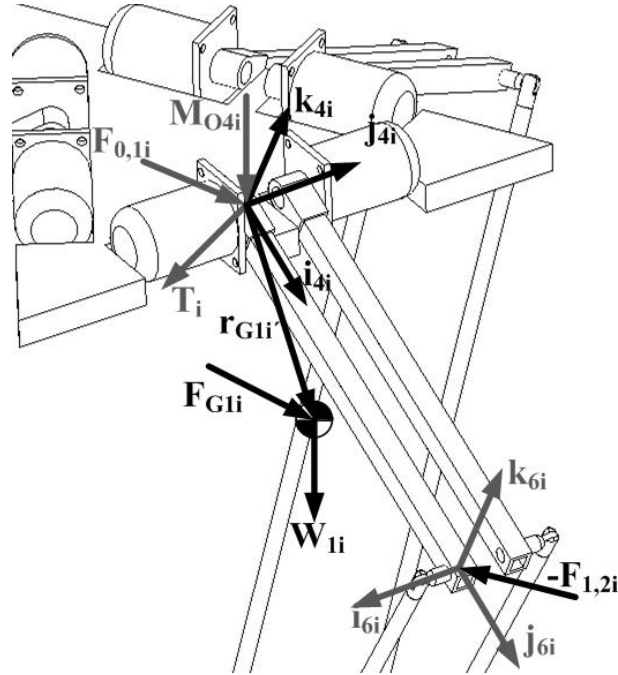
Donde:

$$\begin{aligned} \mathbf{F}_{1_i}^A &= \mathbf{T}_i + \mathbf{Q}_0^{4i} \mathbf{W}_{1_i} \\ \mathbf{F}_{1_i}^R &= \mathbf{F}_{0,1i} - \mathbf{Q}_{6i}^{4i} \mathbf{F}_{1,2i} \\ \mathbf{F}_{1_i}^I &= [\mathbf{F}_{G1i}, \mathbf{M}_{O4i}]^T \end{aligned} \quad (3.2)$$

Además definiendo los elementos del torsor de fuerza inercial:

$$\begin{aligned} \mathbf{F}_{G1i} &= -m_{1_i} \mathbf{a}_{G1i}^{4i} \\ \mathbf{M}_{O4i} &= -\left(\mathbf{J}_{G1i} \boldsymbol{\alpha}_{O1i}^{4i} + \boldsymbol{\omega}_{O1i}^{4i} \times \left(\mathbf{J}_{G1i} \boldsymbol{\omega}_{O1i}^{4i} \right) + \mathbf{r}_{G1i}^{4i} \times \left(m_{1_i} \mathbf{a}_{G1i}^{4i} \right) \right) \end{aligned} \quad (3.3)$$

Se hace notar que las ecuaciones (3.1), (3.2) y (3.3) están definidas en la base local $(\mathbf{i}_{4i}, \mathbf{j}_{4i}, \mathbf{k}_{4i})$. La matriz \mathbf{J}_{G1i} es la matriz de inercias del cuerpo 1_i que se encuentra definida en el centro de gravedad respecto a una base paralela a la base local $(\mathbf{i}_{4i}, \mathbf{j}_{4i}, \mathbf{k}_{4i})$ y se define como:

$$\mathbf{J}_{G1i} = \begin{bmatrix} J_{1ixx} & -J_{1ixy} & -J_{1ixz} \\ -J_{1iyx} & J_{1iyy} & -J_{1iyz} \\ -J_{1izx} & -J_{1izy} & J_{1izz} \end{bmatrix}$$

Además:

$$\begin{aligned} T_i &= [0, 0, 0, 0, T_{mi}, 0]^T \\ W_i &= [0, 0, -m_i g, 0, 0, 0]^T \\ F_{0,1i} &= [F_{01xi}, F_{01yi}, F_{01zi}, M_{01xi}, 0, M_{01zi}]^T \\ F_{1,2i} &= [F_{12xi}, F_{12yi}, F_{12zi}, 0, M_{12yi}, M_{12zi}]^T \end{aligned}$$

Por otro lado se define:

$$Q_m^n = \begin{bmatrix} R_m^n & 0 \\ S_m^n R_m^n & R_m^n \end{bmatrix}$$

Entonces se tiene:

$$\begin{aligned} Q_0^{4i} &= \begin{bmatrix} R_0^{4i} & 0 \\ S_0^{4i} R_0^{4i} & R_0^{4i} \end{bmatrix} \\ Q_{6i}^{4i} &= \begin{bmatrix} R_{6i}^{4i} & 0 \\ S_{6i}^{4i} R_{6i}^{4i} & R_{6i}^{4i} \end{bmatrix} \end{aligned}$$

Las matrices de rotación antes definidas son:

$$\begin{aligned} R_{4i}^0 &= R_{z_6}(\delta_{1i}) R_{z_6}(\delta_{3i}) R_{z_5}(\theta_{4i}) \\ &= R_{z_6}(\delta_{1i} + \delta_{3i}) R_{z_5}(\theta_{4i}) \\ R_0^{4i} &= (R_{4i}^0)^T = R_{z_5}(\theta_{4i})^T R_{z_6}(\delta_{1i} + \delta_{3i})^T \\ &= R_{z_5}(-\theta_{4i}) R_{z_6}(-(\delta_{1i} + \delta_{3i})) \\ R_{6i}^{4i} &= R_{z_6}(\delta_{6i}) \end{aligned}$$

También:

$$\begin{aligned} S_0^{4i} &= S(x_{G1i}, y_{G1i}, z_{G1i}) \\ S_{6i}^{4i} &= S_{z1}(x_{5i}) \end{aligned}$$

Donde S_0^{4i} y S_{6i}^{4i} están definidas en la base local (i_{4i}, j_{4i}, k_{4i}) . Además las matrices antisimétricas S_0^{4i} , S_{6i}^{4i} , están asociadas a los vectores $r_{G1i}^{4i} = [x_{G1i}, y_{G1i}, z_{G1i}]^T$, $r_{4i}^{4i} = [x_{5i}, 0, 0]^T$ respectivamente.

3.2.1.2. Ecuaciones Cinemáticas (Aceleración del centro de gravedad del cuerpo 1.)

El objetivo del planteamiento de ecuaciones cinemáticas, es definir las velocidades y aceleraciones que aparecen en las ecs. (3.3), tales como: a_{G1i}^{4i} , α_{01i}^{4i} y ω_{01i}^{4i} . Dicho proceso se realizará en cada uno de los cuerpos.

Utilizando la representación vectorial se tiene:

$$r_{G1i}^0 = r_{1i}^0 + r_{G1i}^0 \quad (3.4)$$

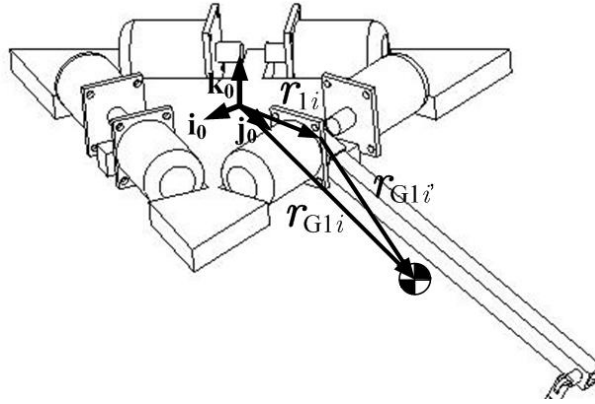
Figura 3.3. Centro de gravedad del cuerpo 1_i

Con el fin de obtener la aceleración del centro de gravedad del cuerpo 1_i y con base en la figura anterior, se tiene la siguiente ecuación de posición definida en la base inercial:

Donde:

$$\begin{aligned} \mathbf{r}_{G1i'}^0 &= \mathbf{R}_{4i}^0 \mathbf{r}_{G1i'}^{4i} \\ \mathbf{r}_{G1i'}^{4i} &= [x_{G1i'}, y_{G1i'}, z_{G1i'}] \end{aligned}$$

Derivando respecto al tiempo a la ec. (3.4) se obtiene la velocidad del centro de gravedad:

$$\begin{aligned} \mathbf{v}_{G1i}^0 &= \mathbf{v}_{i}^0 + \mathbf{v}_{G1i'}^0 = \mathbf{v}_{G1i'}^0 \\ &= \boldsymbol{\omega}_{O1i}^0 \times \mathbf{r}_{G1i'}^0 \end{aligned} \quad (3.5)$$

Donde $\mathbf{v}_{i}^0 = \mathbf{0}$, ya que es un vector de magnitud y orientación constante. Además el vector de velocidad angular inercial $\boldsymbol{\omega}_{O1i}^0$ para el cuerpo 1_i se define como:

$$\boldsymbol{\omega}_{O1i}^0 = \mathbf{R}_{4i}^0 \boldsymbol{\omega}_{i}^{4i} \quad (3.6)$$

El vector de velocidad angular local en la base $(\mathbf{i}_{4i}, \mathbf{j}_{4i}, \mathbf{k}_{4i})$ para el cuerpo 1_i , se define como:

$$\boldsymbol{\omega}_{i}^{4i} = \dot{\theta}_{4i} \mathbf{j}_{3i}^{3i} = \dot{\theta}_{4i} \mathbf{j}_{4i}^{4i} = \dot{\theta}_{4i} [0, 1, 0]^T \quad (3.7)$$

La aceleración del centro de gravedad del cuerpo 1_i se obtiene al derivar respecto al tiempo la ec. (3.5):

$$\begin{aligned} \mathbf{a}_{G1i}^0 &= \mathbf{a}_{G1i'}^0 \\ &= \boldsymbol{\alpha}_{O1i}^0 \times \mathbf{r}_{G1i'}^0 + \boldsymbol{\omega}_{O1i}^0 \times (\boldsymbol{\omega}_{O1i}^0 \times \mathbf{r}_{G1i'}^0) \end{aligned} \quad (3.8)$$

Donde el vector de aceleración angular inercial $(\mathbf{i}_{4i}, \mathbf{j}_{4i}, \mathbf{k}_{4i})$ $\boldsymbol{\alpha}_{O1i}^0$ para el cuerpo 1_i se define como:

$$\boldsymbol{\alpha}_{O1i}^0 = \mathbf{R}_{4i}^0 \boldsymbol{\alpha}_{i}^{4i} \quad (3.9)$$

Donde $\boldsymbol{\alpha}_{i}^{4i}$ está definida en la base local $(\mathbf{i}_{4i}, \mathbf{j}_{4i}, \mathbf{k}_{4i})$:

$$\boldsymbol{\alpha}_{i}^{4i} = \ddot{\theta}_{4i} \mathbf{j}_{3i}^{3i} = \ddot{\theta}_{4i} \mathbf{j}_{4i}^{4i}$$

Hasta este momento se han encontrado las velocidades y aceleraciones \mathbf{a}_{G1i}^0 , $\boldsymbol{\alpha}_{O1i}^0$ y $\boldsymbol{\omega}_{O1i}^0$, definidas en la base inercial, por lo que, a continuación, se proyectarán en la base local con la ayuda de matrices de rotación. Para $\boldsymbol{\omega}_{O1i}^0$:

$$\begin{aligned}\omega_{O1i}^0 &= R_{4i}^0 \omega_{1i}^{4i} \\ \omega_{O1i}^{4i} &= \omega_{1i}^{4i}\end{aligned}\quad (3.10)$$

Para α_{O1i}^0 :

$$\begin{aligned}\alpha_{O1i}^0 &= R_{4i}^0 \alpha_{1i}^{4i} \\ \alpha_{O1i}^{4i} &= \alpha_{1i}^{4i}\end{aligned}\quad (3.11)$$

Para v_{G1i}^0 :

$$\begin{aligned}v_{G1i}^{4i} &= R_0^{4i} v_{G1i}^0 \\ &= R_0^{4i} (\omega_{O1i}^0 \times r_{G1i'}^0) \\ &= R_0^{4i} \omega_{O1i}^0 \times R_0^{4i} r_{G1i'}^0 \\ &= \omega_{1i}^{4i} \times r_{G1i'}^{4i}\end{aligned}\quad (3.12)$$

Para a_{G1i}^0 :

$$\begin{aligned}a_{G1i}^{4i} &= R_0^{4i} a_{G1i}^0 \\ &= R_0^{4i} (\alpha_{O1i}^0 \times r_{G1i'}^0 + \omega_{O1i}^0 \times (\omega_{O1i}^0 \times r_{G1i'}^0)) \\ &= R_0^{4i} \alpha_{O1i}^0 \times R_0^{4i} r_{G1i'}^0 + R_0^{4i} \omega_{O1i}^0 \times (R_0^{4i} \omega_{O1i}^0 \times R_0^{4i} r_{G1i'}^0) \\ &= \alpha_{1i}^{4i} \times r_{G1i'}^{4i} + \omega_{1i}^{4i} \times (\omega_{1i}^{4i} \times r_{G1i'}^{4i})\end{aligned}\quad (3.13)$$

3.2.2. Análisis del Cuerpo 2_i

La Figura 3.4 muestra el diagrama de cuerpo libre del cuerpo 2_i :



Figura 3.4. Diagrama de cuerpo libre del cuerpo 2_i

3.2.2.1. Ecuaciones Dinámicas

Tomando la suma de fuerzas que actúan en el cuerpo 2_i, tenemos:

$$\mathbf{F}_{2i}^A + \mathbf{F}_{2i}^R + \mathbf{F}_{2i}^I = \mathbf{0}\quad (3.14)$$

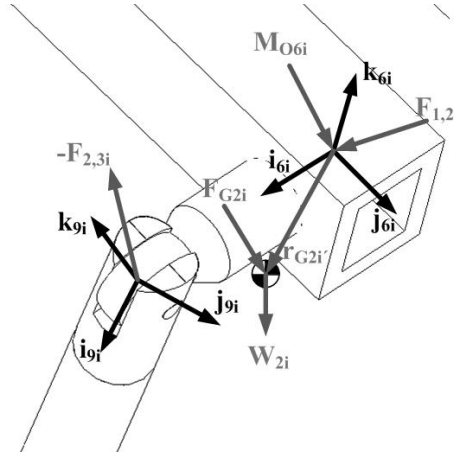
Donde:

$$\begin{aligned} \mathbf{F}_{2i}^A &= \mathbf{Q}_0^{6i} \mathbf{W}_{2i} \\ \mathbf{F}_{2i}^R &= \mathbf{F}_{1,2i} - \mathbf{Q}_{9i}^{6i} \mathbf{F}_{2,3i} \\ \mathbf{F}_{2i}^I &= [\mathbf{F}_{G2i}, \mathbf{M}_{O6i}]^T \end{aligned} \quad (3.15)$$

Además definiendo los elementos del torsor de fuerza inercial:

$$\begin{aligned} \mathbf{F}_{G2i} &= -m_{2i} \mathbf{a}_{G2i}^{6i} \\ \mathbf{M}_{O6i} &= -\left(\mathbf{J}_{G2i} \boldsymbol{\alpha}_{O2i}^{6i} + \boldsymbol{\omega}_{O2i}^{6i} \times \left(\mathbf{J}_{G2i} \boldsymbol{\omega}_{O2i}^{6i} \right) + \mathbf{r}_{G2i}^{6i} \times \left(m_{2i} \mathbf{a}_{G2i}^{6i} \right) \right) \end{aligned} \quad (3.16)$$

Se hace notar que las ecuaciones (3.14), (3.15) y (3.16) están definidas en la base local $(\hat{\mathbf{i}}_{6i}, \hat{\mathbf{j}}_{6i}, \hat{\mathbf{k}}_{6i})$. La matriz \mathbf{J}_{G2i} es la matriz de inercias del cuerpo 2_i que se encuentra definida en la base local $(\hat{\mathbf{i}}_{6i}, \hat{\mathbf{j}}_{6i}, \hat{\mathbf{k}}_{6i})$ y se define como:

$$\mathbf{J}_{G2i} = \begin{bmatrix} \mathbf{J}_{2ixx} & -\mathbf{J}_{2ixy} & -\mathbf{J}_{2ixz} \\ -\mathbf{J}_{2iyx} & \mathbf{J}_{2iyy} & -\mathbf{J}_{2iyz} \\ -\mathbf{J}_{2izx} & -\mathbf{J}_{2izy} & \mathbf{J}_{2izz} \end{bmatrix}$$

Además:

$$\begin{aligned} \mathbf{W}_{2i} &= [0, 0, -m_{2i}g, 0, 0, 0]^T \\ \mathbf{F}_{2,3i} &= [F_{23xi}, F_{23yi}, F_{23zi}, M_{23xi}, 0, M_{23zi}]^T \end{aligned}$$

Por otro lado se tiene:

$$\begin{aligned} \mathbf{Q}_0^{6i} &= \begin{bmatrix} \mathbf{R}_0^{6i} & \mathbf{0} \\ \mathbf{S}_0^{6i} \mathbf{R}_0^{6i} & \mathbf{R}_0^{6i} \end{bmatrix} \\ \mathbf{Q}_{9i}^{6i} &= \begin{bmatrix} \mathbf{R}_{9i}^{6i} & \mathbf{0} \\ \mathbf{S}_{9i}^{6i} \mathbf{R}_{9i}^{6i} & \mathbf{R}_{9i}^{6i} \end{bmatrix} \end{aligned}$$

Las matrices de rotación antes definidas son:

$$\begin{aligned} \mathbf{R}_{6i}^0 &= \mathbf{R}_{z6}(\delta_{1i}) \mathbf{R}_{z6}(\delta_{3i}) \mathbf{R}_{z5}(\theta_{4i}) \mathbf{R}_{z6}(\delta_{6i}) \\ &= \mathbf{R}_{z6}(\delta_{1i} + \delta_{3i}) \mathbf{R}_{z5}(\theta_{4i}) \mathbf{R}_{z6}(\delta_{6i}) \\ \mathbf{R}_0^{6i} &= \left(\mathbf{R}_{6i}^0 \right)^T = \mathbf{R}_{z6}(-\delta_{6i}) \mathbf{R}_{z5}(-\theta_{4i}) \mathbf{R}_{z6}(-(\delta_{1i} + \delta_{3i})) \\ \mathbf{R}_{9i}^{6i} &= \mathbf{R}_{z4}(\theta_{8i}) \mathbf{R}_{z5}(\theta_{9i}) \\ \mathbf{R}_{6i}^{9i} &= \left(\mathbf{R}_{9i}^{6i} \right)^T = \mathbf{R}_{z5}(-\theta_{9i}) \mathbf{R}_{z4}(-\theta_{8i}) \end{aligned}$$

También:

$$\begin{aligned} \mathbf{S}_0^{6i} &= \mathbf{S}(x_{G2i}, y_{G2i}, z_{G2i}) \\ \mathbf{S}_{9i}^{6i} &= \mathbf{S}_{z1}(x_{7i}) \end{aligned}$$

Donde \mathbf{S}_0^{6i} y \mathbf{S}_{9i}^{6i} están definidas en la base local $(\hat{\mathbf{i}}_{6i}, \hat{\mathbf{j}}_{6i}, \hat{\mathbf{k}}_{6i})$. Además la matrices antisimétricas \mathbf{S}_0^{6i} , \mathbf{S}_{9i}^{6i} , están asociadas a los vectores $\mathbf{r}_{G2i}^{6i} = [x_{G2i}, y_{G2i}, z_{G2i}]^T$, $\mathbf{r}_{6i}^{6i} = [x_{7i}, 0, 0]^T$, respectivamente.

3.2.2.2. Ecuaciones Cinemáticas (Aceleración del Centro de Gravedad del Cuerpo 2_i)

El objetivo del planteamiento de ecuaciones cinemáticas, es definir las velocidades y aceleraciones que aparecen en las ecs. (3.16), tales como: \mathbf{a}_{G2i}^{6i} , $\boldsymbol{\alpha}_{O2i}^{6i}$ y $\boldsymbol{\omega}_{O2i}^{6i}$. Utilizando la representación vectorial se tiene:



Figura 3.5. Centro de gravedad del cuerpo 2_i

Con el fin de obtener la aceleración del centro de gravedad del cuerpo 2_i y con base en la figura anterior, se tiene la siguiente ecuación de posición definida en la base inercial:

$$\mathbf{r}_{G2i}^0 = \mathbf{r}_{1i}^0 + \mathbf{r}_{4i}^0 + \mathbf{r}_{G2i'}^0 \quad (3.17)$$

Donde:

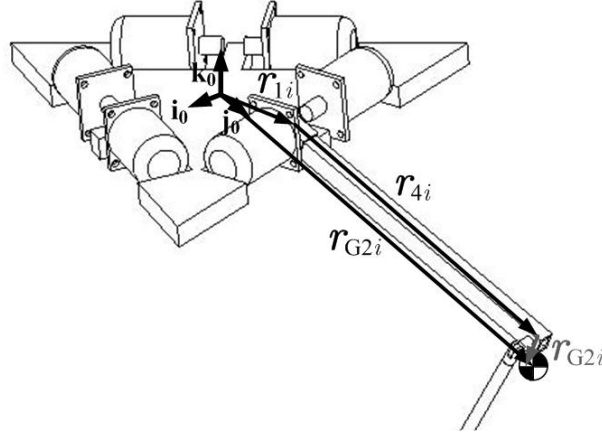
$$\begin{aligned} \mathbf{r}_{4i}^0 &= \mathbf{R}_{4i}^0 \mathbf{r}_{4i}^{4i} \\ \mathbf{r}_{G2i'}^0 &= \mathbf{R}_{6i}^0 \mathbf{r}_{G2i'}^{6i} \\ \mathbf{r}_{4i}^{4i} &= [x_{5i}, 0, 0] \\ \mathbf{r}_{G2i'}^{6i} &= [x_{G2i'}, y_{G2i'}, z_{G2i'}] \end{aligned}$$

Derivando respecto al tiempo a la ec. (3.17) se obtiene la velocidad del centro de gravedad:

$$\begin{aligned} \mathbf{v}_{G2i}^0 &= \mathbf{v}_{1i}^0 + \mathbf{v}_{4i}^0 + \mathbf{v}_{G2i'}^0 = \mathbf{v}_{1i}^0 + \mathbf{v}_{G2i'}^0 \\ &= \boldsymbol{\omega}_{O1i}^0 \times \mathbf{r}_{4i}^0 + \boldsymbol{\omega}_{O2i}^0 \times \mathbf{r}_{G2i'}^0 \end{aligned} \quad (3.18)$$

Donde $\mathbf{v}_{1i}^0 = \mathbf{0}$, ya que es un vector de magnitud y orientación constante. Además el vector de velocidad angular inercial $\boldsymbol{\omega}_{O2i}^0$ para el cuerpo 2_i se define como:

$$\begin{aligned} \boldsymbol{\omega}_{O2i}^0 &= \boldsymbol{\omega}_{1i}^0 + \boldsymbol{\omega}_{2i}^0 \\ &= \mathbf{R}_{4i}^0 \boldsymbol{\omega}_{1i}^{4i} + \mathbf{R}_{8i}^0 \boldsymbol{\omega}_{2i}^{8i} \end{aligned} \quad (3.19)$$

El vector de velocidad angular local en la base $(\mathbf{i}_{8i}, \mathbf{j}_{8i}, \mathbf{k}_{8i})$ para el cuerpo 2_i, se define como:

$$\boldsymbol{\omega}_{2i}^{8i} = \dot{\theta}_{8i} \mathbf{i}_{7i}^{7i} = \dot{\theta}_{8i} \mathbf{i}_{8i}^{8i} = \dot{\theta}_{8i} [1, 0, 0]^T \quad (3.20)$$

Además:

$$\begin{aligned} \mathbf{R}_{8i}^0 &= \mathbf{R}_{z6}(\delta_{1i}) \mathbf{R}_{z6}(\delta_{3i}) \mathbf{R}_{z5}(\theta_{4i}) \mathbf{R}_{z6}(\delta_{6i}) \mathbf{R}_{z4}(\theta_{8i}) \\ &= \mathbf{R}_{z6}(\delta_{1i} + \delta_{3i}) \mathbf{R}_{z5}(\theta_{4i}) \mathbf{R}_{z6}(\delta_{6i}) \mathbf{R}_{z4}(\theta_{8i}) \end{aligned}$$

La aceleración del centro de gravedad del cuerpo 2_i se obtiene al derivar respecto al tiempo la ec. (3.18):

$$\begin{aligned} \mathbf{a}_{G2i}^0 &= \mathbf{a}_{4i}^0 + \mathbf{a}_{G2i'}^0 \\ &= \boldsymbol{\alpha}_{O1i}^0 \times \mathbf{r}_{4i}^0 + \boldsymbol{\omega}_{O1i}^0 \times (\boldsymbol{\omega}_{O1i}^0 \times \mathbf{r}_{4i}^0) + \boldsymbol{\alpha}_{O2i}^0 \times \mathbf{r}_{G2i'}^0 + \boldsymbol{\omega}_{O2i}^0 \times (\boldsymbol{\omega}_{O2i}^0 \times \mathbf{r}_{G2i'}^0) \end{aligned} \quad (3.21)$$

Donde el vector de aceleración angular inercial $\boldsymbol{\alpha}_{O2i}^0$ para el cuerpo 2_i se define como:

$$\begin{aligned} \boldsymbol{\alpha}_{O2i}^0 &= \boldsymbol{\alpha}_{1i}^0 + \boldsymbol{\alpha}_{2i}^0 + \boldsymbol{\omega}_{1i}^0 \times \boldsymbol{\omega}_{2i}^0 \\ &= \mathbf{R}_{4i}^0 \boldsymbol{\alpha}_{1i}^{4i} + \mathbf{R}_{8i}^0 \boldsymbol{\alpha}_{2i}^{8i} + \mathbf{R}_{4i}^0 \boldsymbol{\omega}_{1i}^{4i} \times \mathbf{R}_{8i}^0 \boldsymbol{\omega}_{2i}^{8i} \end{aligned} \quad (3.22)$$

Donde $\boldsymbol{\alpha}_{2i}^{8i}$ está definida en la base local $(\mathbf{i}_{8i}, \mathbf{j}_{8i}, \mathbf{k}_{8i})$:

$$\boldsymbol{\alpha}_{2i}^{8i} = \ddot{\theta}_{8i} \mathbf{i}_{7i} = \ddot{\theta}_{8i} \mathbf{i}_{8i}^{8i}$$

Hasta este momento se han encontrado las velocidades y aceleraciones \mathbf{a}_{G2i}^0 , $\boldsymbol{\alpha}_{O2i}^0$ y $\boldsymbol{\omega}_{O2i}^0$, definidas en la base inercial, por lo que, a continuación, se proyectarán en la base local $(\mathbf{i}_{6i}, \mathbf{j}_{6i}, \mathbf{k}_{6i})$ con la ayuda de matrices de rotación. Para $\boldsymbol{\omega}_{O2i}^0$:

$$\begin{aligned} \boldsymbol{\omega}_{O2i}^{6i} &= \mathbf{R}_0^{6i} \boldsymbol{\omega}_{O2i}^0 \\ &= \mathbf{R}_0^{6i} (\mathbf{R}_{4i}^0 \boldsymbol{\omega}_{1i}^{4i} + \mathbf{R}_{8i}^0 \boldsymbol{\omega}_{2i}^{8i}) \\ &= \mathbf{R}_{4i}^{6i} \boldsymbol{\omega}_{1i}^{4i} + \mathbf{R}_{8i}^{6i} \boldsymbol{\omega}_{2i}^{8i} \\ &= \mathbf{R}_{4i}^{6i} \boldsymbol{\omega}_{1i}^{4i} + \boldsymbol{\omega}_{2i}^{8i} \end{aligned} \quad (3.23)$$

Donde $\mathbf{R}_{8i}^{6i} \boldsymbol{\omega}_{2i}^{8i} = \boldsymbol{\omega}_{2i}^{8i} = \boldsymbol{\omega}_{2i}^{6i}$, ya que la matriz de rotación y la velocidad angular tienen el mismo eje de giro. Además:

$$\mathbf{R}_{6i}^{4i} = \mathbf{R}_{z6}(\delta_{6i})$$

$$\mathbf{R}_{4i}^{6i} = \mathbf{R}_{z6}(-\delta_{6i})$$

$$\mathbf{R}_{8i}^{6i} = \mathbf{R}_{z4}(\theta_{8i})$$

$$\mathbf{R}_{6i}^{8i} = \mathbf{R}_{z4}(-\theta_{8i})$$

Para $\boldsymbol{\alpha}_{O2i}^0$:

$$\begin{aligned} \boldsymbol{\alpha}_{O2i}^{6i} &= \mathbf{R}_0^{6i} \boldsymbol{\alpha}_{O2i}^0 \\ &= \mathbf{R}_0^{6i} (\mathbf{R}_{4i}^0 \boldsymbol{\alpha}_{1i}^{4i} + \mathbf{R}_{8i}^0 \boldsymbol{\alpha}_{2i}^{8i} + \mathbf{R}_{4i}^0 \boldsymbol{\omega}_{1i}^{4i} \times \mathbf{R}_{8i}^0 \boldsymbol{\omega}_{2i}^{8i}) \\ &= \mathbf{R}_{4i}^{6i} \boldsymbol{\alpha}_{1i}^{4i} + \mathbf{R}_{8i}^{6i} \boldsymbol{\alpha}_{2i}^{8i} + \mathbf{R}_{4i}^{6i} \boldsymbol{\omega}_{1i}^{4i} \times \mathbf{R}_{8i}^{6i} \boldsymbol{\omega}_{2i}^{8i} \\ &= \mathbf{R}_{4i}^{6i} \boldsymbol{\alpha}_{1i}^{4i} + \boldsymbol{\alpha}_{2i}^{8i} + \mathbf{R}_{4i}^{6i} \boldsymbol{\omega}_{1i}^{4i} \times \boldsymbol{\omega}_{2i}^{8i} \end{aligned} \quad (3.24)$$

Para \mathbf{v}_{G2i}^0 :

$$\begin{aligned} \mathbf{v}_{G2i}^{6i} &= \mathbf{R}_0^{6i} \mathbf{v}_{G2i}^0 \\ &= \mathbf{R}_0^{6i} (\boldsymbol{\omega}_{O1i}^0 \times \mathbf{r}_{4i}^0 + \boldsymbol{\omega}_{O2i}^0 \times \mathbf{r}_{G2i'}^0) \\ &= \boldsymbol{\omega}_{O1i}^{6i} \times \mathbf{r}_{4i}^{6i} + \boldsymbol{\omega}_{O2i}^{6i} \times \mathbf{r}_{G2i'}^{6i} \end{aligned} \quad (3.25)$$

Para \mathbf{a}_{G2i}^0 :

$$\begin{aligned} \mathbf{a}_{G2i}^{6i} &= \mathbf{R}_0^{6i} \mathbf{a}_{G2i}^0 \\ &= \mathbf{R}_0^{6i} \left(\boldsymbol{\alpha}_{O1i}^0 \times \mathbf{r}_{4i}^0 + \boldsymbol{\omega}_{O1i}^0 \times (\boldsymbol{\omega}_{O1i}^0 \times \mathbf{r}_{4i}^0) + \boldsymbol{\alpha}_{O2i}^0 \times \mathbf{r}_{G2i'}^0 + \boldsymbol{\omega}_{O2i}^0 \times (\boldsymbol{\omega}_{O2i}^0 \times \mathbf{r}_{G2i'}^0) \right) \\ &= \boldsymbol{\alpha}_{O1i}^{6i} \times \mathbf{r}_{4i}^{6i} + \boldsymbol{\omega}_{O1i}^{6i} \times (\boldsymbol{\omega}_{O1i}^{6i} \times \mathbf{r}_{4i}^{6i}) + \boldsymbol{\alpha}_{O2i}^{6i} \times \mathbf{r}_{G2i'}^{6i} + \boldsymbol{\omega}_{O2i}^{6i} \times (\boldsymbol{\omega}_{O2i}^{6i} \times \mathbf{r}_{G2i'}^{6i}) \end{aligned} \quad (3.26)$$

Donde los vectores de posición, velocidad y aceleración definidos en la base $(\mathbf{i}_{6i}, \mathbf{j}_{6i}, \mathbf{k}_{6i})$ son, respectivamente:

$$\mathbf{r}_{4i}^{6i} = \mathbf{R}_{4i}^{6i} \mathbf{r}_{4i}^{4i}$$

$$\begin{aligned} \boldsymbol{\omega}_{O1i}^{6i} &= \mathbf{R}_0^{6i} \boldsymbol{\omega}_{O1i}^0 \\ &= \mathbf{R}_0^{6i} \mathbf{R}_{4i}^0 \boldsymbol{\omega}_{1i}^{4i} = \mathbf{R}_{4i}^{6i} \boldsymbol{\omega}_{1i}^{4i} \end{aligned} \quad (3.27)$$

$$\boldsymbol{\alpha}_{O1i}^{6i} = \mathbf{R}_{4i}^{6i} \boldsymbol{\alpha}_{1i}^{4i}$$

3.2.3. Análisis del Cuerpo 3_i

La Figura 3.6 muestra el diagrama de cuerpo libre del cuerpo 3_i :



Figura 3.6. Diagrama de cuerpo libre del cuerpo 3_i

3.2.3.1. Ecuaciones Dinámicas

Tomando la suma de fuerzas que actúan en el cuerpo 3_i, tenemos:

$$\mathbf{F}_{3i}^A + \mathbf{F}_{3i}^R + \mathbf{F}_{3i}^I = \mathbf{0} \quad (3.28)$$

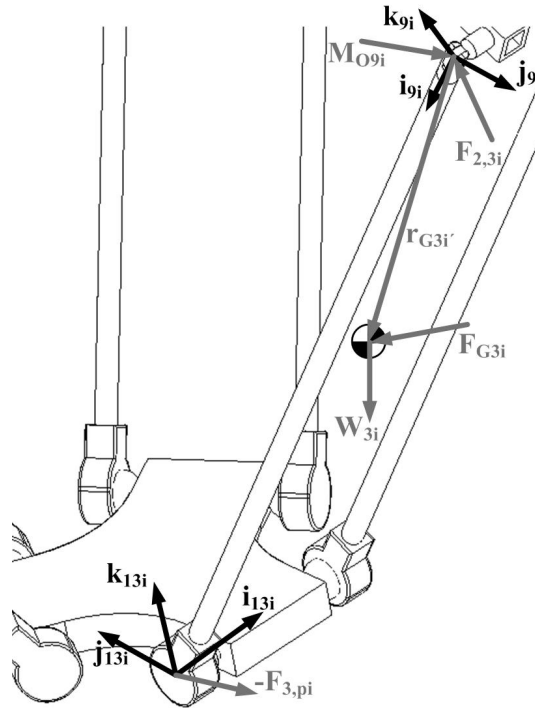
Donde:

$$\begin{aligned} \mathbf{F}_{3i}^A &= \mathbf{Q}_0^{9i} \mathbf{W}_{3i} \\ \mathbf{F}_{3i}^R &= \mathbf{F}_{2,3i} - \mathbf{Q}_{13i}^{9i} \mathbf{F}_{3,pi} \\ \mathbf{F}_{3i}^I &= [\mathbf{F}_{G3i}, \mathbf{M}_{O9i}]^T \end{aligned} \quad (3.29)$$

Además, definiendo los elementos del torsor de fuerza inercial:

$$\begin{aligned} \mathbf{F}_{G3i} &= -m_{3i} \mathbf{a}_{G3i}^{9i} \\ \mathbf{M}_{O9i} &= -\left(\mathbf{J}_{G3i} \boldsymbol{\alpha}_{O3i}^{9i} + \boldsymbol{\omega}_{O3i}^{9i} \times \left(\mathbf{J}_{G3i} \boldsymbol{\omega}_{O3i}^{9i} \right) + \mathbf{r}_{G3i'}^{9i} \times \left(m_{3i} \mathbf{a}_{G3i}^{9i} \right) \right) \end{aligned} \quad (3.30)$$

Se hace notar que las ecuaciones (3.28), (3.29) y (3.30) están definidas en la base local $(\hat{\mathbf{i}}_{9i}, \hat{\mathbf{j}}_{9i}, \hat{\mathbf{k}}_{9i})$. La matriz \mathbf{J}_{G3i} es la matriz de inercias del cuerpo 3_i que se encuentra definida en la base local $(\hat{\mathbf{i}}_{9i}, \hat{\mathbf{j}}_{9i}, \hat{\mathbf{k}}_{9i})$ y se define como:

$$\mathbf{J}_{G3i} = \begin{bmatrix} \mathbf{J}_{3ixx} & -\mathbf{J}_{3ixy} & -\mathbf{J}_{3ixz} \\ -\mathbf{J}_{3iyx} & \mathbf{J}_{3iyy} & -\mathbf{J}_{3iyz} \\ -\mathbf{J}_{3izx} & -\mathbf{J}_{3izy} & \mathbf{J}_{3izz} \end{bmatrix}$$

Además:

$$\begin{aligned} \mathbf{W}_{3i} &= [0, 0, -m_{3i}g, 0, 0, 0]^T \\ \mathbf{F}_{3,pi} &= [F_{3pxi}, F_{3pyi}, F_{3pzi}, 0, 0, 0]^T \end{aligned}$$

Por otro lado se tiene:

$$\begin{aligned} \mathbf{Q}_0^{9i} &= \begin{bmatrix} \mathbf{R}_0^{9i} & \mathbf{0} \\ \mathbf{S}_0^{9i} \mathbf{R}_0^{9i} & \mathbf{R}_0^{9i} \end{bmatrix} \\ \mathbf{Q}_{13i}^{9i} &= \begin{bmatrix} \mathbf{R}_{13i}^{9i} & \mathbf{0} \\ \mathbf{S}_{13i}^{9i} \mathbf{R}_{13i}^{9i} & \mathbf{R}_{13i}^{9i} \end{bmatrix} \end{aligned}$$

Las matrices de rotación antes definidas son:

$$\begin{aligned} \mathbf{R}_{9i}^0 &= \mathbf{R}_{z6}(\delta_{1i}) \mathbf{R}_{z6}(\delta_{3i}) \mathbf{R}_{z5}(\theta_{4i}) \mathbf{R}_{z6}(\delta_{6i}) \mathbf{R}_{z4}(\theta_{8i}) \mathbf{R}_{z5}(\theta_{9i}) \\ &= \mathbf{R}_{z6}(\delta_{1i} + \delta_{3i}) \mathbf{R}_{z5}(\theta_{4i}) \mathbf{R}_{z6}(\delta_{6i}) \mathbf{R}_{z4}(\theta_{8i}) \mathbf{R}_{z5}(\theta_{9i}) \\ \mathbf{R}_0^{9i} &= \left(\mathbf{R}_{9i}^0 \right)^T = \mathbf{R}_{z5}(-\theta_{9i}) \mathbf{R}_{z4}(-\theta_{8i}) \mathbf{R}_{z6}(-\delta_{6i}) \mathbf{R}_{z5}(-\theta_{4i}) \mathbf{R}_{z6}(-(\delta_{1i} + \delta_{3i})) \\ \mathbf{R}_{13i}^{9i} &= \mathbf{R}_{z6}(\theta_{11i}) \mathbf{R}_{z4}(\theta_{12i}) \mathbf{R}_{z6}(\theta_{13i}) \\ \mathbf{R}_{9i}^{13i} &= \left(\mathbf{R}_{13i}^{9i} \right)^T = \mathbf{R}_{z6}(-\theta_{13i}) \mathbf{R}_{z4}(-\theta_{12i}) \mathbf{R}_{z6}(-\theta_{11i}) \end{aligned}$$

También:

$$\begin{aligned} \mathbf{S}_0^{9i} &= \mathbf{S}(x_{G3i}, y_{G3i}, z_{G3i}) \\ \mathbf{S}_{13i}^{9i} &= \mathbf{S}_{z1}(x_{10i}) \end{aligned}$$

Donde S_0^{9i} y S_{13i}^{9i} están definidas en la base local (i_{9i}, j_{9i}, k_{9i}) . Además la matrices antisimétricas S_0^{9i} , S_{13i}^{9i} , están asociadas a los vectores $r_{G3i'}^{9i} = [x_{G3i'}, y_{G3i'}, z_{G3i'}]^T$, $r_{9i}^{9i} = [x_{10i}, 0, 0]^T$, respectivamente.

3.2.3.2. Ecuaciones Cinemáticas (Aceleración del Centro de Gravedad del Cuerpo 3_i)

El objetivo del planteamiento de ecuaciones cinemáticas, es definir las velocidades y aceleraciones que aparecen en las ecs. (3.30), tales como: a_{G3i}^{9i} , α_{O3i}^{9i} y ω_{O3i}^{9i} . Utilizando la representación vectorial se tiene:



Figura 3.7. Centro de gravedad del cuerpo 3_i

Con el fin de obtener la aceleración del centro de gravedad del cuerpo 3_i y con base en la figura anterior, se tiene la siguiente ecuación de Posición definida en la base inercial:

$$r_{G3i}^0 = r_{1i}^0 + r_{4i}^0 + r_{6i}^0 + r_{G3i'}^0 \quad (3.31)$$

Donde:

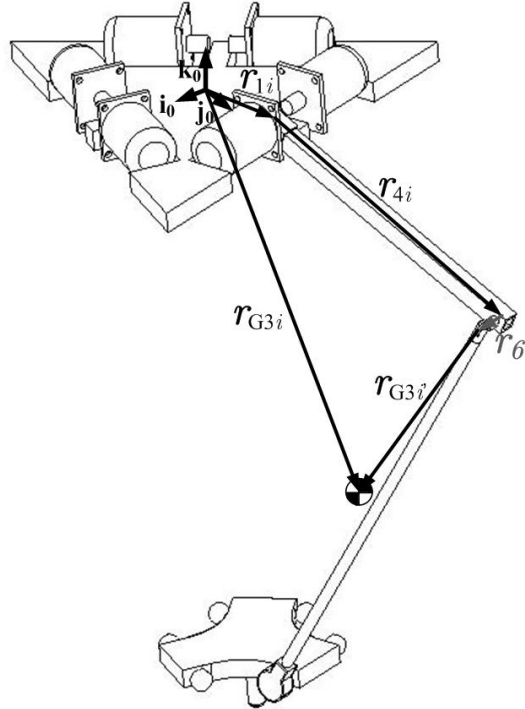
$$\begin{aligned} r_{6i}^0 &= R_{6i}^0 r_{6i}^{6i} \\ r_{G3i'}^0 &= R_{9i}^0 r_{G3i'}^{9i} \\ r_{6i}^{6i} &= [x_{7i}, 0, 0] \\ r_{G3i'}^{9i} &= [x_{G3i'}, y_{G3i'}, z_{G3i'}] \end{aligned}$$

Derivando respecto al tiempo a la ec. (3.31) se obtiene la velocidad del centro de gravedad:

$$\begin{aligned} v_{G3i}^0 &= v_{1i}^0 + v_{4i}^0 + v_{6i}^0 + v_{G3i'}^0 = v_{4i}^0 + v_{6i}^0 + v_{G3i'}^0 \\ &= \omega_{O1i}^0 \times r_{4i}^0 + \omega_{O2i}^0 \times r_{6i}^0 + \omega_{O3i}^0 \times r_{G3i'}^0 \end{aligned} \quad (3.32)$$

Donde $\mathbf{v}_{1i}^0 = \mathbf{0}$, ya que es un vector de magnitud y orientación constante. Además el vector de velocidad angular inercial $\boldsymbol{\omega}_{03i}^0$ para el cuerpo 3_i se define como:

$$\begin{aligned}\boldsymbol{\omega}_{03i}^0 &= \boldsymbol{\omega}_{1i}^0 + \boldsymbol{\omega}_{2i}^0 + \boldsymbol{\omega}_{3i}^0 \\ &= \mathbf{R}_{4i}^0 \boldsymbol{\omega}_{1i}^{4i} + \mathbf{R}_{8i}^0 \boldsymbol{\omega}_{2i}^{8i} + \mathbf{R}_{9i}^0 \boldsymbol{\omega}_{3i}^{9i}\end{aligned}\quad (3.33)$$

El vector de velocidad angular local en la base $(\mathbf{i}_{9i}, \mathbf{j}_{9i}, \mathbf{k}_{9i})$ para el cuerpo 3_i , se define como:

$$\boldsymbol{\omega}_{3i}^{9i} = \dot{\theta}_{9i} \mathbf{j}_{8i}^{8i} = \dot{\theta}_{9i} \mathbf{j}_{9i}^{9i} = \dot{\theta}_{9i} [0, 1, 0]^T \quad (3.34)$$

La aceleración del centro de gravedad del cuerpo 3_i se obtiene al derivar respecto al tiempo la ec. (3.32):

$$\begin{aligned}\mathbf{a}_{G3i}^0 &= \mathbf{a}_{4i}^0 + \mathbf{a}_{6i}^0 + \mathbf{a}_{G3i}^0 \\ &= \boldsymbol{\alpha}_{01i}^0 \times \mathbf{r}_{4i}^0 + \boldsymbol{\omega}_{01i}^0 \times (\boldsymbol{\omega}_{01i}^0 \times \mathbf{r}_{4i}^0) + \boldsymbol{\alpha}_{02i}^0 \times \mathbf{r}_{6i}^0 + \boldsymbol{\omega}_{02i}^0 \times (\boldsymbol{\omega}_{02i}^0 \times \mathbf{r}_{6i}^0) + \\ &\quad \boldsymbol{\alpha}_{03i}^0 \times \mathbf{r}_{G3i}^0 + \boldsymbol{\omega}_{03i}^0 \times (\boldsymbol{\omega}_{03i}^0 \times \mathbf{r}_{G3i}^0)\end{aligned}\quad (3.35)$$

Donde el vector de aceleración angular inercial $\boldsymbol{\alpha}_{03i}^0$ para el cuerpo 3_i se define como:

$$\begin{aligned}\boldsymbol{\alpha}_{03i}^0 &= \boldsymbol{\alpha}_{1i}^0 + \boldsymbol{\alpha}_{2i}^0 + \boldsymbol{\alpha}_{3i}^0 + \boldsymbol{\omega}_{1i}^0 \times \boldsymbol{\omega}_{2i}^0 + (\boldsymbol{\omega}_{1i}^0 + \boldsymbol{\omega}_{2i}^0) \times \boldsymbol{\omega}_{3i}^0 \\ &= \mathbf{R}_{4i}^0 \boldsymbol{\alpha}_{1i}^{4i} + \mathbf{R}_{8i}^0 \boldsymbol{\alpha}_{2i}^{8i} + \mathbf{R}_{9i}^0 \boldsymbol{\alpha}_{3i}^{9i} + \boldsymbol{\omega}_{1i}^0 \times \boldsymbol{\omega}_{2i}^0 + (\boldsymbol{\omega}_{1i}^0 + \boldsymbol{\omega}_{2i}^0) \times \boldsymbol{\omega}_{3i}^0\end{aligned}\quad (3.36)$$

Donde $\boldsymbol{\alpha}_{3i}^{9i}$ está definida en la base local $(\mathbf{i}_{9i}, \mathbf{j}_{9i}, \mathbf{k}_{9i})$:

$$\boldsymbol{\alpha}_{3i}^{9i} = \ddot{\theta}_{9i} \mathbf{j}_{8i}^{8i} = \ddot{\theta}_{9i} \mathbf{j}_{9i}^{9i}$$

Hasta este momento se han encontrado las velocidades y aceleraciones \mathbf{a}_{G3i}^0 , $\boldsymbol{\alpha}_{03i}^0$ y $\boldsymbol{\omega}_{03i}^0$, definidas en la base inercial, por lo que, a continuación, se proyectarán en la base local $(\mathbf{i}_{9i}, \mathbf{j}_{9i}, \mathbf{k}_{9i})$ con la ayuda de matrices de rotación. Para $\boldsymbol{\omega}_{03i}^0$:

$$\begin{aligned}\boldsymbol{\omega}_{03i}^0 &= \mathbf{R}_0^{9i} \boldsymbol{\omega}_{03i}^0 \\ &= \mathbf{R}_0^{9i} (\mathbf{R}_{4i}^0 \boldsymbol{\omega}_{1i}^{4i} + \mathbf{R}_{8i}^0 \boldsymbol{\omega}_{2i}^{8i} + \mathbf{R}_{9i}^0 \boldsymbol{\omega}_{3i}^{9i}) \\ &= \mathbf{R}_{4i}^{9i} \boldsymbol{\omega}_{1i}^{4i} + \mathbf{R}_{8i}^{9i} \boldsymbol{\omega}_{2i}^{8i} + \boldsymbol{\omega}_{3i}^{9i} \\ &= \boldsymbol{\omega}_{1i}^{9i} + \boldsymbol{\omega}_{2i}^{9i} + \boldsymbol{\omega}_{3i}^{9i}\end{aligned}\quad (3.37)$$

Donde:

$$\begin{aligned}\mathbf{R}_{9i}^{4i} &= \mathbf{R}_{z6} (\delta_{6i}) \mathbf{R}_{z4} (\theta_{8i}) \mathbf{R}_{z5} (\theta_{9i}) \\ \mathbf{R}_{4i}^{9i} &= \mathbf{R}_{z5} (-\theta_{9i}) \mathbf{R}_{z4} (-\theta_{8i}) \mathbf{R}_{z6} (-\delta_{6i}) \\ \mathbf{R}_{9i}^{8i} &= \mathbf{R}_{z5} (\theta_{9i}) \\ \mathbf{R}_{8i}^{9i} &= \mathbf{R}_{z5} (-\theta_{9i})\end{aligned}$$

Para $\boldsymbol{\alpha}_{03i}^0$:

$$\begin{aligned}
\boldsymbol{\alpha}_{O3i}^{9i} &= \mathbf{R}_0^{9i} \boldsymbol{\alpha}_{O3i}^0 \\
&= \mathbf{R}_0^{9i} \left(\mathbf{R}_{4i}^0 \boldsymbol{\alpha}_{1i}^{4i} + \mathbf{R}_{8i}^0 \boldsymbol{\alpha}_{2i}^{8i} + \mathbf{R}_{9i}^0 \boldsymbol{\alpha}_{3i}^{9i} + \boldsymbol{\omega}_{1i}^0 \times \boldsymbol{\omega}_{2i}^0 + (\boldsymbol{\omega}_{1i}^0 + \boldsymbol{\omega}_{2i}^0) \times \boldsymbol{\omega}_{3i}^0 \right) \\
&= \mathbf{R}_{4i}^{9i} \boldsymbol{\alpha}_{1i}^{4i} + \mathbf{R}_{8i}^{9i} \boldsymbol{\alpha}_{2i}^{8i} + \boldsymbol{\alpha}_{3i}^{9i} + \boldsymbol{\omega}_{1i}^{9i} \times \boldsymbol{\omega}_{2i}^{9i} + (\boldsymbol{\omega}_{1i}^{9i} + \boldsymbol{\omega}_{2i}^{9i}) \times \boldsymbol{\omega}_{3i}^{9i}
\end{aligned} \tag{3.38}$$

Para \mathbf{v}_{G3i}^0 :

$$\begin{aligned}
\mathbf{v}_{G3i}^{9i} &= \mathbf{R}_0^{9i} \mathbf{v}_{G3i}^0 \\
&\mathbf{R}_0^{9i} \left(\boldsymbol{\omega}_{O1i}^0 \times \mathbf{r}_{4i}^0 + \boldsymbol{\omega}_{O2i}^0 \times \mathbf{r}_{6i}^0 + \boldsymbol{\omega}_{O3i}^0 \times \mathbf{r}_{G3i'}^0 \right) \\
&= \boldsymbol{\omega}_{O1i}^{9i} \times \mathbf{r}_{4i}^{9i} + \boldsymbol{\omega}_{O2i}^{9i} \times \mathbf{r}_{6i}^{9i} + \boldsymbol{\omega}_{O3i}^{9i} \times \mathbf{r}_{G3i'}^{9i}
\end{aligned} \tag{3.39}$$

Para \mathbf{a}_{G3i}^0 :

$$\begin{aligned}
\mathbf{a}_{G3i}^{9i} &= \mathbf{R}_0^{9i} \mathbf{a}_{G3i}^0 \\
&= \mathbf{R}_0^{9i} \left(\boldsymbol{\alpha}_{O1i}^0 \times \mathbf{r}_{4i}^0 + \boldsymbol{\omega}_{O1i}^0 \times (\boldsymbol{\omega}_{O1i}^0 \times \mathbf{r}_{4i}^0) + \boldsymbol{\alpha}_{O2i}^0 \times \mathbf{r}_{6i}^0 + \boldsymbol{\omega}_{O2i}^0 \times (\boldsymbol{\omega}_{O2i}^0 \times \mathbf{r}_{6i}^0) + \right. \\
&\quad \left. \boldsymbol{\alpha}_{O3i}^0 \times \mathbf{r}_{G3i'}^0 + \boldsymbol{\omega}_{O3i}^0 \times (\boldsymbol{\omega}_{O3i}^0 \times \mathbf{r}_{G3i'}^0) \right) \\
&= \boldsymbol{\alpha}_{O1i}^{9i} \times \mathbf{r}_{4i}^{9i} + \boldsymbol{\omega}_{O1i}^{9i} \times (\boldsymbol{\omega}_{O1i}^{9i} \times \mathbf{r}_{4i}^{9i}) + \boldsymbol{\alpha}_{O2i}^{9i} \times \mathbf{r}_{6i}^{9i} + \boldsymbol{\omega}_{O2i}^{9i} \times (\boldsymbol{\omega}_{O2i}^{9i} \times \mathbf{r}_{6i}^{9i}) + \\
&\quad \boldsymbol{\alpha}_{O3i}^{9i} \times \mathbf{r}_{G3i'}^{9i} + \boldsymbol{\omega}_{O3i}^{9i} \times (\boldsymbol{\omega}_{O3i}^{9i} \times \mathbf{r}_{G3i'}^{9i})
\end{aligned} \tag{3.40}$$

Donde los vectores de posición definidos en la base $(\mathbf{i}_{9i}, \mathbf{j}_{9i}, \mathbf{k}_{9i})$ son:

$$\begin{aligned}
\mathbf{r}_{4i}^{9i} &= \mathbf{R}_{4i}^{9i} \mathbf{r}_{4i}^{4i} \\
\mathbf{r}_{6i}^{9i} &= \mathbf{R}_{6i}^{9i} \mathbf{r}_{6i}^{6i}
\end{aligned} \tag{3.41}$$

Los vectores de velocidad angular definidos en la base $(\mathbf{i}_{9i}, \mathbf{j}_{9i}, \mathbf{k}_{9i})$ son:

$$\begin{aligned}
\boldsymbol{\omega}_{O1i}^{9i} &= \mathbf{R}_0^{9i} \boldsymbol{\omega}_{O1i}^0 \\
&= \mathbf{R}_0^{9i} \mathbf{R}_{4i}^0 \boldsymbol{\omega}_{1i}^{4i} = \mathbf{R}_{4i}^{9i} \boldsymbol{\omega}_{1i}^{4i} \\
\boldsymbol{\omega}_{O2i}^{9i} &= \mathbf{R}_0^{9i} \boldsymbol{\omega}_{O2i}^0 \\
&= \mathbf{R}_0^{9i} \left(\mathbf{R}_{4i}^0 \boldsymbol{\omega}_{1i}^{4i} + \mathbf{R}_{8i}^0 \boldsymbol{\omega}_{2i}^{8i} \right) = \mathbf{R}_{4i}^{9i} \boldsymbol{\omega}_{1i}^{4i} + \mathbf{R}_{8i}^{9i} \boldsymbol{\omega}_{2i}^{8i}
\end{aligned} \tag{3.42}$$

Los vectores de aceleración angular definidos en la base $(\mathbf{i}_{9i}, \mathbf{j}_{9i}, \mathbf{k}_{9i})$ son:

$$\begin{aligned}
\boldsymbol{\alpha}_{O1i}^{9i} &= \mathbf{R}_0^{9i} \boldsymbol{\alpha}_{O1i}^0 \\
&= \mathbf{R}_0^{9i} \mathbf{R}_{4i}^0 \boldsymbol{\alpha}_{1i}^{4i} = \mathbf{R}_{4i}^{9i} \boldsymbol{\alpha}_{1i}^{4i} \\
\boldsymbol{\alpha}_{O2i}^{9i} &= \mathbf{R}_0^{9i} \boldsymbol{\alpha}_{O2i}^0 \\
&= \mathbf{R}_0^{9i} \left(\mathbf{R}_{4i}^0 \boldsymbol{\alpha}_{1i}^{4i} + \mathbf{R}_{8i}^0 \boldsymbol{\alpha}_{2i}^{8i} + \mathbf{R}_{4i}^0 \boldsymbol{\omega}_{1i}^{4i} \times \mathbf{R}_{8i}^0 \boldsymbol{\omega}_{2i}^{8i} \right) \\
&= \mathbf{R}_{4i}^{9i} \boldsymbol{\alpha}_{1i}^{4i} + \mathbf{R}_{8i}^{9i} \boldsymbol{\alpha}_{2i}^{8i} + \mathbf{R}_{4i}^{9i} \boldsymbol{\omega}_{1i}^{4i} \times \mathbf{R}_{8i}^{9i} \boldsymbol{\omega}_{2i}^{8i}
\end{aligned} \tag{3.43}$$

3.2.4. Análisis del Plato Móvil y Carga

Las Figura 3.8 muestra el diagrama de cuerpo libre del Plato Móvil:



Figura 3.8. Diagramas de cuerpo libre del plato móvil y la carga

3.2.4.1. Ecuaciones Dinámicas

Tomando la suma de fuerzas que actúan en el plato móvil, tenemos:

$$\mathbf{F}_p^A + \mathbf{F}_p^R + \mathbf{F}_p^I = \mathbf{0} \quad (3.44)$$

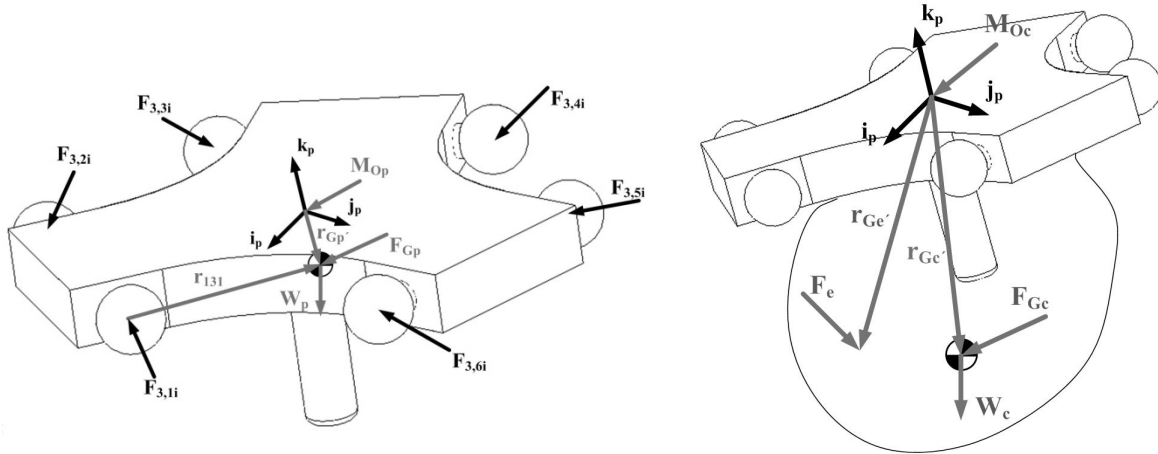
Donde:

$$\begin{aligned} \mathbf{F}_p^A &= Q_{0,e}^p \mathbf{F}_e + Q_{0,c}^p \mathbf{W}_c + Q_{0,p}^p \mathbf{W}_p \\ \mathbf{F}_p^R &= \sum_{i=1}^6 Q_{13i}^p \mathbf{F}_{3,pi} \\ \mathbf{F}_p^I &= [\mathbf{F}_{Gp}, \mathbf{M}_{Op}]^T \end{aligned} \quad (3.45)$$

Además, definiendo los elementos del torsor de fuerza inercial:

$$\begin{aligned} \mathbf{F}_{Gp} &= \mathbf{F}_p + \mathbf{F}_c \\ &= -(m_p \mathbf{a}_{Gp}^p + m_c \mathbf{a}_{Gc}^p) \\ \mathbf{M}_{Op} &= \mathbf{M}_p + \mathbf{M}_c \\ \mathbf{M}_p &= -(\mathbf{J}_{Gp} \boldsymbol{\alpha}_{Op}^p + \boldsymbol{\omega}_{Op}^p \times (\mathbf{J}_{Gp} \boldsymbol{\omega}_{Op}^p) + \mathbf{r}_{Gp}^p \times (m_p \mathbf{a}_{Gp}^p)) \\ \mathbf{M}_c &= -(\mathbf{J}_{Gc} \boldsymbol{\alpha}_{Oc}^p + \boldsymbol{\omega}_{Oc}^p \times (\mathbf{J}_{Gc} \boldsymbol{\omega}_{Oc}^p) + \mathbf{r}_{Gc}^p \times (m_c \mathbf{a}_{Gc}^p)) \end{aligned} \quad (3.46)$$

Se hace notar que las ecuaciones (3.44), (3.45) y (3.46) están definidas en la base local $(\mathbf{i}_p, \mathbf{j}_p, \mathbf{k}_p)$. La matriz \mathbf{J}_{Gp} y \mathbf{J}_{Gc} son las matrices de inercia del plato móvil y de la carga respectivamente, y se encuentran definidas en la base local $(\mathbf{i}_p, \mathbf{j}_p, \mathbf{k}_p)$ y se definen como:

$$\mathbf{J}_{Gp} = \begin{bmatrix} \mathbf{J}_{p_{xx}} & -\mathbf{J}_{p_{xy}} & -\mathbf{J}_{p_{xz}} \\ -\mathbf{J}_{p_{yx}} & \mathbf{J}_{p_{yy}} & -\mathbf{J}_{p_{yz}} \\ -\mathbf{J}_{p_{zx}} & -\mathbf{J}_{p_{zy}} & \mathbf{J}_{p_{zz}} \end{bmatrix} \quad \mathbf{J}_{Gc} = \begin{bmatrix} \mathbf{J}_{c_{xx}} & -\mathbf{J}_{c_{xy}} & -\mathbf{J}_{c_{xz}} \\ -\mathbf{J}_{c_{yx}} & \mathbf{J}_{c_{yy}} & -\mathbf{J}_{c_{yz}} \\ -\mathbf{J}_{c_{zx}} & -\mathbf{J}_{c_{zy}} & \mathbf{J}_{c_{zz}} \end{bmatrix}$$

Además:

$$\begin{aligned} \mathbf{W}_p &= [0, 0, -m_p g, 0, 0, 0]^T \\ \mathbf{W}_c &= [0, 0, -m_c g, 0, 0, 0]^T \\ \mathbf{F}_e &= [F_{ex}, F_{ey}, F_{ez}, M_{ex}, M_{ey}, M_{ez}]^T \\ \mathbf{F}_{3,pi} &= [F_{3pxi}, F_{3pyi}, F_{3pzi}, 0, 0, 0]^T \end{aligned}$$

Donde \mathbf{W}_p y \mathbf{W}_c son los torsores de peso del plato móvil y la carga (cuerpo irregular) que soportará el robot, así como, \mathbf{F}_e es el torsor al cual será sometido el plato móvil al trasladar la carga de un lugar a otro. Por otro lado se tiene:

$$\begin{aligned} \mathbf{Q}_{0,e}^p &= \begin{bmatrix} \mathbf{R}_0^p & \mathbf{0} \\ \mathbf{S}_{0,e}^p \mathbf{R}_0^p & \mathbf{R}_0^p \end{bmatrix} & \mathbf{Q}_{0,c}^p &= \begin{bmatrix} \mathbf{R}_0^p & \mathbf{0} \\ \mathbf{S}_{0,c}^p \mathbf{R}_0^p & \mathbf{R}_0^p \end{bmatrix} \\ \mathbf{Q}_{0,p}^p &= \begin{bmatrix} \mathbf{R}_0^p & \mathbf{0} \\ \mathbf{S}_{0,p}^p \mathbf{R}_0^p & \mathbf{R}_0^p \end{bmatrix} & \mathbf{Q}_{13i}^p &= \begin{bmatrix} \mathbf{R}_{13i}^p & \mathbf{0} \\ \mathbf{S}_{13i}^p \mathbf{R}_{13i}^p & \mathbf{R}_{13i}^p \end{bmatrix} \end{aligned}$$

Las matrices de rotación antes definidas son:

$$\begin{aligned} \mathbf{R}_p^0 &= \mathbf{R}_{z6}(\psi) \mathbf{R}_{z4}(\theta) \mathbf{R}_{z6}(\phi) \\ \mathbf{R}_0^p &= (\mathbf{R}_p^0)^T = \mathbf{R}_{z6}(-\phi) \mathbf{R}_{z4}(-\theta) \mathbf{R}_{z6}(-\psi) \\ \mathbf{R}_p^{13i} &= \mathbf{R}_{z6}(\delta_{15i} + \delta_{17i}) \\ \mathbf{R}_{13i}^p &= (\mathbf{R}_p^{13i})^T = \mathbf{R}_{z6}(-(\delta_{15i} + \delta_{17i})) \end{aligned}$$

También:

$$\begin{aligned} \mathbf{S}_{0,e}^p &= \mathcal{S}(x_e, y_e, z_e) \\ \mathbf{S}_{0,c}^p &= \mathcal{S}(x_{Gc}, y_{Gc}, z_{Gc}) \\ \mathbf{S}_{0,p}^p &= \mathcal{S}(x_{Gp}, y_{Gp}, z_{Gp}) \\ \mathbf{S}_{13i}^p &= \mathbf{R}_{z6}(\delta_{17i})^T \mathcal{S}_{z1}(-x_{16i}) \mathbf{R}_{z6}(\delta_{17i}) + \mathbf{R}_{z6}(\delta_{15i} + \delta_{17i})^T \mathcal{S}_{z1}(-x_{14i}) \mathbf{R}_{z6}(\delta_{15i} + \delta_{17i}) \\ &= \mathbf{R}_{z6}(-\delta_{17i}) \mathcal{S}_{z1}(-x_{16i}) \mathbf{R}_{z6}(\delta_{17i}) + \mathbf{R}_{z6}(-(\delta_{15i} + \delta_{17i})) \mathcal{S}_{z1}(-x_{14i}) \mathbf{R}_{z6}(\delta_{15i} + \delta_{17i}) \\ &= \mathbf{R}_{z6}(-\delta_{17i}) (\mathcal{S}_{z1}(-x_{16i}) + \mathbf{R}_{z6}(-\delta_{15i}) \mathcal{S}_{z1}(-x_{14i}) \mathbf{R}_{z6}(\delta_{15i})) \mathbf{R}_{z6}(\delta_{17i}) \end{aligned}$$

Donde $\mathbf{S}_{0,e}^p$, $\mathbf{S}_{0,c}^p$, $\mathbf{S}_{0,p}^p$ y \mathbf{S}_{13i}^p están definidas en la base local $(\mathbf{i}_p, \mathbf{j}_p, \mathbf{k}_p)$. Además las matrices antisimétricas $\mathbf{S}_{0,e}^p$, $\mathbf{S}_{0,c}^p$, $\mathbf{S}_{0,p}^p$ y \mathbf{S}_{13i}^p están asociadas a los vectores $\mathbf{r}_e^p = [x_e, y_e, z_e]^T$, $\mathbf{r}_{Gc}^p = [x_{Gc}, y_{Gc}, z_{Gc}]^T$, $\mathbf{r}_{Gp}^p = [x_{Gp}, y_{Gp}, z_{Gp}]^T$ y \mathbf{r}_{13i}^p , respectivamente.

3.2.4.2. Ecuaciones Cinemáticas (Aceleración del Centro de Gravedad del Plato Móvil y Carga)

El objetivo del planteamiento de ecuaciones cinemáticas, es definir las velocidades y aceleraciones que aparecen en las ecs. (3.46), tales como: \mathbf{a}_{Gp}^p , \mathbf{a}_{Op}^p , $\mathbf{\omega}_{Op}^p$, \mathbf{a}_{Gc}^p , \mathbf{a}_{Oc}^p y $\mathbf{\omega}_{Oc}^p$.

Utilizando la representación vectorial se tiene:



Figura 3.9. Centro de gravedad del plato móvil y la carga

Con el fin de obtener la aceleración del centro de gravedad del plato móvil y con base en la figura anterior, se tiene la siguiente ecuación de posición definida en la base inercial:

$$\mathbf{r}_{G_p}^0 = \mathbf{r}_p^0 + \mathbf{r}_{G_{p'}}^0 \quad (3.47)$$

Donde:

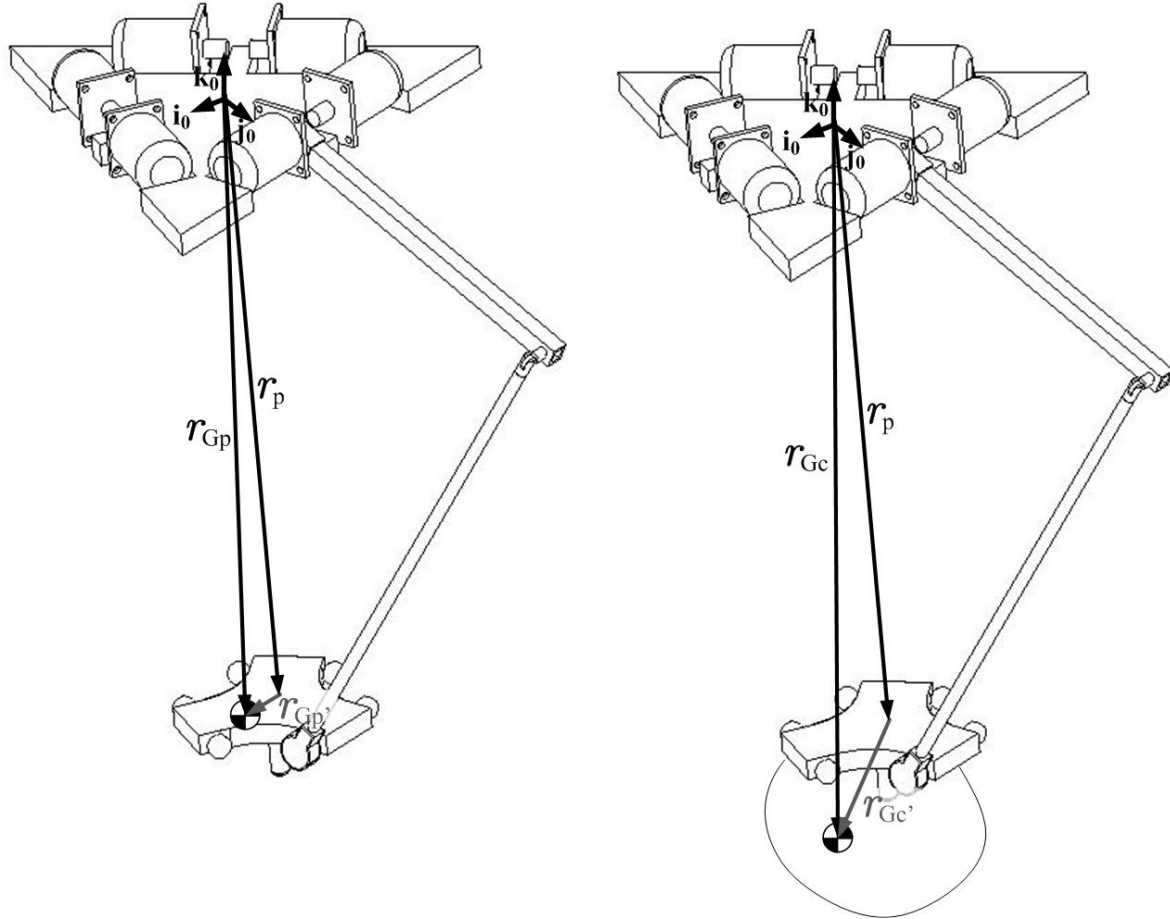
$$\begin{aligned} \mathbf{r}_p^0 &= [x_p, y_p, z_p]^T \\ \mathbf{r}_{G_{p'}}^0 &= \mathbf{R}_p^0 \mathbf{r}_{G_{p'}}^p \\ \mathbf{r}_{G_{p'}}^p &= [x_{G_{p'}}, y_{G_{p'}}, z_{G_{p'}}]^T \end{aligned}$$

Derivando respecto al tiempo a la ec. (3.47) se obtiene la velocidad del centro de gravedad del plato móvil:

$$\begin{aligned} \mathbf{v}_{G_p}^0 &= \mathbf{v}_p^0 + \mathbf{v}_{G_{p'}}^0 \\ &= \mathbf{v}_p^0 + \boldsymbol{\omega}_{O_p}^0 \times \mathbf{r}_{G_{p'}}^0 \end{aligned} \quad (3.48)$$

Donde:

$$\mathbf{v}_p^0 = [\dot{x}_p, \dot{y}_p, \dot{z}_p]^T \quad (3.49)$$

Además, el vector de velocidad angular inercial $\boldsymbol{\omega}_{O_p}^0$ del plato móvil se define como:

$$\begin{aligned}\boldsymbol{\omega}_{Op}^0 &= \boldsymbol{\omega}_\psi^0 + \boldsymbol{\omega}_\theta^0 + \boldsymbol{\omega}_\phi^0 \\ &= \boldsymbol{\omega}_\psi^0 + \mathbf{R}_{18}^0 \boldsymbol{\omega}_\theta^{18} + \mathbf{R}_{19}^0 \boldsymbol{\omega}_\phi^{19}\end{aligned}\quad (3.50)$$

Los vectores de velocidad angular locales son:

$$\begin{aligned}\boldsymbol{\omega}_\psi^0 &= \dot{\psi} \mathbf{k}_0^0 & \mathbf{k}_0^0 &= [0, 0, 1]^T \\ \boldsymbol{\omega}_\theta^{18} &= \dot{\theta} \mathbf{i}_{18}^{18} & \mathbf{i}_{18}^{18} &= [1, 0, 0]^T \\ \boldsymbol{\omega}_\phi^{19} &= \dot{\phi} \mathbf{k}_{19}^{19} & \mathbf{k}_{19}^{19} &= [0, 0, 1]^T\end{aligned}\quad (3.51)$$

La aceleración del centro de gravedad del plato móvil se obtiene al derivar respecto al tiempo la ec. (3.48):

$$\begin{aligned}\mathbf{a}_{Gp}^0 &= \mathbf{a}_p^0 + \mathbf{a}_{Gp'}^0 \\ &= \mathbf{a}_p^0 + \boldsymbol{\alpha}_{Op}^0 \times \mathbf{r}_{Gp'}^0 + \boldsymbol{\omega}_{Op}^0 \times (\boldsymbol{\omega}_{Op}^0 \times \mathbf{r}_{Gp'}^0)\end{aligned}\quad (3.52)$$

Donde:

$$\mathbf{a}_p^0 = [\ddot{x}_p, \ddot{y}_p, \ddot{z}_p]^T \quad (3.53)$$

Además, el vector de aceleración angular inercial $\boldsymbol{\alpha}_{Op}^0$ del plato móvil se define como:

$$\begin{aligned}\boldsymbol{\alpha}_{Op}^0 &= \boldsymbol{\alpha}_\psi^0 + \boldsymbol{\alpha}_\theta^0 + \boldsymbol{\alpha}_\phi^0 + \boldsymbol{\omega}_\psi^0 \times \boldsymbol{\omega}_\theta^0 + (\boldsymbol{\omega}_\psi^0 + \boldsymbol{\omega}_\theta^0) \times \boldsymbol{\omega}_\phi^0 \\ &= \boldsymbol{\alpha}_\psi^0 + \mathbf{R}_{18}^0 \boldsymbol{\alpha}_\theta^{18} + \mathbf{R}_{19}^0 \boldsymbol{\alpha}_\phi^{19} + \boldsymbol{\omega}_\psi^0 \times \boldsymbol{\omega}_\theta^0 + (\boldsymbol{\omega}_\psi^0 + \boldsymbol{\omega}_\theta^0) \times \boldsymbol{\omega}_\phi^0\end{aligned}\quad (3.54)$$

Donde las matrices de rotación anteriores son:

$$\begin{aligned}\mathbf{R}_{18i}^0 &= \mathbf{R}_{z_6}(\psi) \\ \mathbf{R}_{19i}^0 &= \mathbf{R}_{z_6}(\psi) \mathbf{R}_{z_4}(\theta)\end{aligned}$$

Los vectores de aceleración angular locales son:

$$\begin{aligned}\boldsymbol{\alpha}_\psi^0 &= \ddot{\psi} \mathbf{k}_0^0 \\ \boldsymbol{\alpha}_\theta^{18} &= \ddot{\theta} \mathbf{i}_{18}^{18} \\ \boldsymbol{\alpha}_\phi^{19} &= \ddot{\phi} \mathbf{k}_{19}^{19}\end{aligned}$$

Ahora, con el fin de obtener la aceleración del centro de gravedad de la carga, se tiene la siguiente ecuación de lazo definida en la base inercial:

$$\mathbf{r}_{Gc}^0 = \mathbf{r}_p^0 + \mathbf{r}_{Gc'}^0 \quad (3.55)$$

Donde:

$$\begin{aligned}\mathbf{r}_{Gc'}^0 &= \mathbf{R}_p^0 \mathbf{r}_{Gc'}^p \\ \mathbf{r}_{Gc'}^p &= [x_{Gc'}, y_{Gc'}, z_{Gc'}]^T\end{aligned}$$

Derivando respecto al tiempo a la ec. (3.55) se obtiene la velocidad del centro de gravedad de la carga:

$$\begin{aligned}\mathbf{v}_{Gc}^0 &= \mathbf{v}_p^0 + \mathbf{v}_{Gc'}^0 \\ &= \mathbf{v}_p^0 + \boldsymbol{\omega}_{Oc}^0 \times \mathbf{r}_{Gc'}^0\end{aligned}\quad (3.56)$$

El vector de velocidad angular inercial $\boldsymbol{\omega}_{Oc}^0$ de la carga se define como:

$$\boldsymbol{\omega}_{Oc}^0 = \boldsymbol{\omega}_{Op}^0 \quad (3.57)$$

La aceleración del centro de gravedad del plato móvil se obtiene al derivar respecto al tiempo la ec. (3.56):

$$\begin{aligned} \mathbf{a}_{Gc}^0 &= \mathbf{a}_p^0 + \mathbf{a}_{Gc'}^0 \\ &= \mathbf{a}_p^0 + \boldsymbol{\alpha}_{Oc}^0 \times \mathbf{r}_{Gc'}^0 + \boldsymbol{\omega}_{Oc}^0 \times (\boldsymbol{\omega}_{Oc}^0 \times \mathbf{r}_{Gc'}^0) \end{aligned} \quad (3.58)$$

El vector de aceleración angular inercial $\boldsymbol{\alpha}_{Oc}^0$ del plato móvil se define como:

$$\boldsymbol{\alpha}_{Oc}^0 = \boldsymbol{\alpha}_{Op}^0 \quad (3.59)$$

Hasta este momento se han encontrado las velocidades y aceleraciones $\mathbf{a}_{Gp}^0, \boldsymbol{\alpha}_{Op}^0, \boldsymbol{\omega}_{Op}^0, \mathbf{a}_{Gc}^0, \boldsymbol{\alpha}_{Oc}^0$ y $\boldsymbol{\omega}_{Oc}^0$ definidas en la base inercial, por lo que, a continuación, se proyectarán en la base local $(\mathbf{i}_p, \mathbf{j}_p, \mathbf{k}_p)$ con la ayuda de matrices de rotación. Para $\boldsymbol{\omega}_{Op}^0$:

$$\begin{aligned} \boldsymbol{\omega}_{Op}^p &= \mathbf{R}_0^p \boldsymbol{\omega}_{Op}^0 \\ &= \mathbf{R}_0^p (\boldsymbol{\omega}_\psi^0 + \mathbf{R}_{18}^0 \boldsymbol{\omega}_\theta^{18} + \mathbf{R}_{19}^0 \boldsymbol{\omega}_\phi^{19}) \\ &= \mathbf{R}_0^p \boldsymbol{\omega}_\psi^0 + \mathbf{R}_{18}^p \boldsymbol{\omega}_\theta^{18} + \mathbf{R}_{19}^p \boldsymbol{\omega}_\phi^{19} \\ &= \boldsymbol{\omega}_\psi^p + \boldsymbol{\omega}_\theta^p + \boldsymbol{\omega}_\phi^p \end{aligned} \quad (3.60)$$

$$\mathbf{R}_0^p = (\mathbf{R}_p^0)^T = \mathbf{R}_{z_6} (-\phi) \mathbf{R}_{z_4} (-\theta) \mathbf{R}_{z_6} (-\psi)$$

Donde:

$$\begin{aligned} \mathbf{R}_p^{18} &= \mathbf{R}_{z_4} (\theta) \mathbf{R}_{z_6} (\phi) \\ \mathbf{R}_{18}^p &= \mathbf{R}_{z_6} (-\phi) \mathbf{R}_{z_4} (-\theta) \\ \mathbf{R}_p^{19} &= \mathbf{R}_{z_6} (\phi) \\ \mathbf{R}_{19}^p &= \mathbf{R}_{z_6} (-\phi) \end{aligned}$$

Para $\boldsymbol{\alpha}_{Op}^0$:

$$\begin{aligned} \boldsymbol{\alpha}_{Op}^p &= \mathbf{R}_0^p \boldsymbol{\alpha}_{Op}^0 \\ &= \mathbf{R}_0^p (\boldsymbol{\alpha}_\psi^0 + \mathbf{R}_{18}^0 \boldsymbol{\alpha}_\theta^{18} + \mathbf{R}_{19}^0 \boldsymbol{\alpha}_\phi^{19} + \boldsymbol{\omega}_\psi^0 \times \boldsymbol{\omega}_\theta^0 + (\boldsymbol{\omega}_\psi^0 + \boldsymbol{\omega}_\theta^0) \times \boldsymbol{\omega}_\phi^0) \\ &= \mathbf{R}_0^p \boldsymbol{\alpha}_\psi^0 + \mathbf{R}_{18}^p \boldsymbol{\alpha}_\theta^{18} + \mathbf{R}_{19}^p \boldsymbol{\alpha}_\phi^{19} + \boldsymbol{\omega}_\psi^p \times \boldsymbol{\omega}_\theta^p + (\boldsymbol{\omega}_\psi^p + \boldsymbol{\omega}_\theta^p) \times \boldsymbol{\omega}_\phi^p \end{aligned} \quad (3.61)$$

Para \mathbf{v}_{Gp}^0 :

$$\begin{aligned} \mathbf{v}_{Gp}^p &= \mathbf{R}_0^p \mathbf{v}_{Gp}^0 \\ &= \mathbf{R}_0^p (\mathbf{v}_p^0 + \boldsymbol{\omega}_{Op}^0 \times \mathbf{r}_{Gp'}^0) \\ &= \mathbf{R}_0^p \mathbf{v}_p^0 + \boldsymbol{\omega}_{Op}^p \times \mathbf{r}_{Gp'}^p \end{aligned} \quad (3.62)$$

Para \mathbf{a}_{Gp}^0 :

$$\begin{aligned}
\mathbf{a}_{Gp}^p &= \mathbf{R}_0^p \mathbf{a}_{Gp}^0 \\
&= \mathbf{R}_0^p \left(\mathbf{a}_p^0 + \boldsymbol{\alpha}_{Op}^0 \times \mathbf{r}_{Gp'}^0 + \boldsymbol{\omega}_{Op}^0 \times (\boldsymbol{\omega}_{Op}^0 \times \mathbf{r}_{Gp'}^0) \right) \\
&= \mathbf{R}_0^p \mathbf{a}_p^0 + \boldsymbol{\alpha}_{Op}^p \times \mathbf{r}_{Gp'}^p + \boldsymbol{\omega}_{Op}^p \times (\boldsymbol{\omega}_{Op}^p \times \mathbf{r}_{Gp'}^p)
\end{aligned} \tag{3.63}$$

Para \mathbf{v}_{Gc}^0 :

$$\begin{aligned}
\mathbf{v}_{Gc}^p &= \mathbf{R}_0^p \mathbf{v}_{Gc}^0 \\
&= \mathbf{R}_0^p \left(\mathbf{v}_p^0 + \boldsymbol{\omega}_{Oc}^0 \times \mathbf{r}_{Gc'}^0 \right) \\
&= \mathbf{R}_0^p \mathbf{v}_p^0 + \boldsymbol{\omega}_{Oc}^p \times \mathbf{r}_{Gc'}^p
\end{aligned} \tag{3.64}$$

Para \mathbf{a}_{Gc}^0 :

$$\begin{aligned}
\mathbf{a}_{Gc}^p &= \mathbf{R}_0^p \mathbf{a}_{Gc}^0 \\
&= \mathbf{R}_0^p \left(\mathbf{a}_p^0 + \boldsymbol{\alpha}_{Oc}^0 \times \mathbf{r}_{Gc'}^0 + \boldsymbol{\omega}_{Oc}^0 \times (\boldsymbol{\omega}_{Oc}^0 \times \mathbf{r}_{Gc'}^0) \right) \\
&= \mathbf{R}_0^p \mathbf{a}_p^0 + \boldsymbol{\alpha}_{Oc}^p \times \mathbf{r}_{Gc'}^p + \boldsymbol{\omega}_{Oc}^p \times (\boldsymbol{\omega}_{Oc}^p \times \mathbf{r}_{Gc'}^p)
\end{aligned} \tag{3.65}$$

3.2.5. Solución del Método Newton-Euler

El análisis dinámico que se desarrolló en los subcapítulos anteriores, como se mencionó en la introducción del presente capítulo, tiene como fin; encontrar los torques necesarios para desplazar al efector final y su carga de un punto inicial a un punto final, a través de la trayectoria descrita en el apéndice B; así como las fuerzas de reacción en las juntas del robot.

Se tiene que cada cadena cinemática consta de 3 cuerpos: cuerpo 1_i, cuerpo 2_i, cuerpo 3_i. Para cada cuerpo se pueden escribir 6 ecuaciones escalares dinámicas: 3 ecuaciones de suma de fuerzas y 3 ecuaciones de suma de momentos. Por lo tanto, para cada cadena cinemática se tienen 18 ecuaciones escalares. Finalmente, el sistema total consta de 6 cadenas más el efector final, lo cual produce 114 ecuaciones escalares dinámicas. Por otra parte, el número de incógnitas en el sistema está asociado a las juntas cinemáticas.

Una cadena consta de:

- 1 Junta Rotacional– Uniendo la base y el cuerpo 1_i
- 1 Junta Rotacional– Uniendo el cuerpo 1_i y el cuerpo 2_i
- 1 Junta Rotacional– Uniendo el cuerpo 2_i y el cuerpo 3_i
- 1 Junta Esférica– Uniendo el cuerpo 3_i y el plato móvil

Si la junta rotacional proporciona 5 incógnitas de reacción a calcular y la junta esférica proporciona 3 incógnitas de reacción, se tienen para cadena entonces:

$$\begin{array}{r}
3 \text{ Juntas Rotacionales} = 15 \text{ incógnitas} \\
1 \text{ Junta Esférica} = 3 \text{ incógnitas} \\
\hline
\text{Total} = 18 \text{ incógnitas}
\end{array}$$

Por lo tanto, para las 6 cadenas se tienen 108 incógnitas. Tomando en cuenta que los grados de libertad del robot hexa son 6, se requieren entonces 6 torques, $\tau_{m1}, \tau_{m2}, \tau_{m3}, \tau_{m5}, \tau_{m6}$,

asociados a los ángulos $\theta_{41}, \theta_{42}, \theta_{43}, \theta_{44}, \theta_{45}, \theta_{46}$ respectivamente, que son necesarios para desplazar y orientar el efector final. En definitiva se tiene un total de 114 incógnitas, lo que hace compatible el sistema de 114 ecuaciones x 114 incógnitas. Para la solución de este método se empleó el software Mathematica v 5.0, con el cual se obtuvo la solución para condiciones estáticas y dinámicas. Además, se usó el software Solid Edge, con el cual, después de modelar cada una de las piezas del robot, se obtuvieron los momentos de inercia de cada uno de los cuerpos.

Para el cuerpo 1_i se tienen las siguientes características físicas:

$$m_{1i} = 0.159437 \text{ Kg}$$

$$\mathbf{r}_{G1i'}^{4i} = [0.137887436, 0, 0]^T \text{ m}$$

$$\mathbf{J}_{G1i} = \begin{bmatrix} 0.000012 & 0 & 0 \\ 0 & 0.004466 & 0 \\ 0 & 0 & 0.004464 \end{bmatrix} \text{ Kg}\cdot\text{m}^2$$

Para el cuerpo 2_i se tienen las siguientes características físicas:

$$m_{2i} = 0.008 \text{ Kg}$$

$$\mathbf{r}_{G2i'}^{6i} = [0.01806, 0, 0]^T \text{ m}$$

$$\mathbf{J}_{G2i} = \begin{bmatrix} 0.092 \times 10^{-6} & 0 & 0 \\ 0 & 3.486 \times 10^{-6} & 0 \\ 0 & 0 & 3.477 \times 10^{-6} \end{bmatrix} \text{ Kg}\cdot\text{m}^2$$

Para el cuerpo 3_i se tienen las siguientes características físicas:

$$m_{3i} = 0.144355 \text{ Kg}$$

$$\mathbf{r}_{G3i'}^{9i} = [0.316002151, 0, 0.000128425]^T \text{ m}$$

$$\mathbf{J}_{G3i} = \begin{bmatrix} 0.000004 & 0 & -0.000011 \\ 0 & 0.018668 & 0 \\ -0.000011 & 0 & 0.018670 \end{bmatrix} \text{ Kg}\cdot\text{m}^2$$

Para el plato móvil se tienen las siguientes características físicas:

$$m_p = 0.771888 \text{ Kg}$$

$$\mathbf{r}_{Gp}^p = [0, 0, -0.010079736]^T \text{ m}$$

$$\mathbf{J}_{Gp} = \begin{bmatrix} 0.001237 & 0 & 0 \\ 0 & 0.001237 & 0 \\ 0 & 0 & 0.002213 \end{bmatrix} \text{ Kg}\cdot\text{m}^2$$

Para la carga se tienen las siguientes características físicas:

$$m_c = 0.9 \text{ Kg}$$

$$\mathbf{r}_{G_c}^p = [0, 0, -0.020]^T \text{ m}$$

$$\mathbf{J}_{G_c} = \begin{bmatrix} 2(0.001237) & 0 & 0 \\ 0 & 2(0.001237) & 0 \\ 0 & 0 & 2(0.002213) \end{bmatrix} \text{ Kg}\cdot\text{m}^2$$

Dicha carga representa un cuerpo que es transportado por el robot y la cual permanece fija respecto al efector final del mismo.

Para \mathbf{F}_e se tiene:

$$\mathbf{F}_e = [F_{ex}, F_{ey}, F_{ez}, M_{ex}, M_{ey}, M_{ez}]^T$$

$$\mathbf{F}_e = [0, 0, 0, 0, 0, 0]^T$$

El punto de acción del torsor \mathbf{F}_e es:

$$\mathbf{r}_{G_e}^p = [0, 0, 0]^T \text{ m}$$

Dicho torsor estará formado por las fuerzas y/o momentos que se presentarían si el robot tuviera en su efector final una herramienta (taladro, fresa, punzador, etc.) o simplemente se presentara un obstáculo el cual le impida su movimiento.

En la Figura 3.10 se muestra la gráfica de torques obtenida para el análisis estático, correspondiente a la trayectoria trazada en el Apéndice B, con las siguientes designaciones:



Figura 3.10 Gráfica de torques estáticos (Newton-Euler)

En la Figura 3.11 se muestra la gráfica de torques obtenida para el análisis dinámico, correspondiente a la trayectoria trazada en el Apéndice B, con las siguientes designaciones:

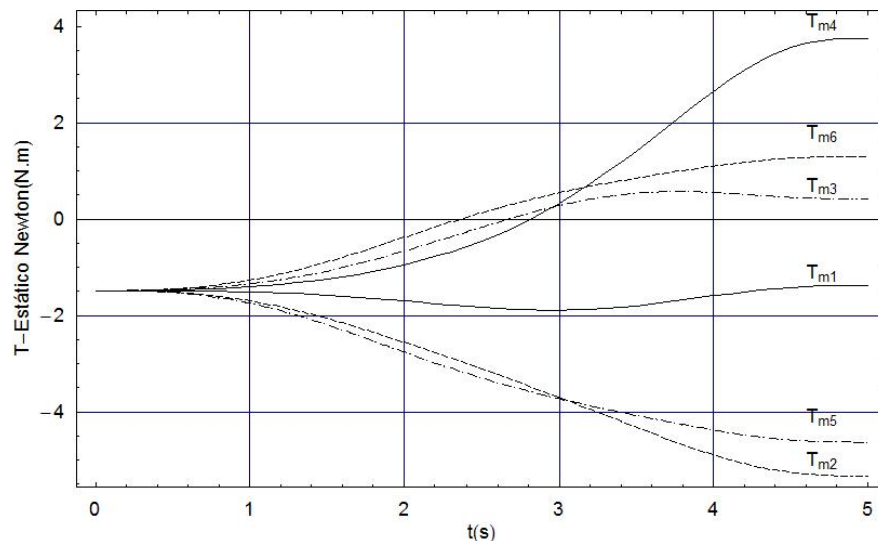
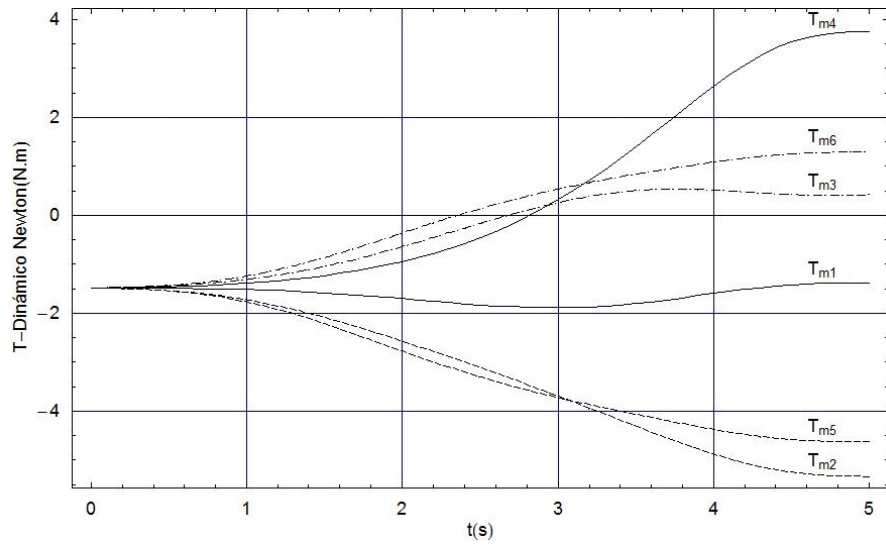

Capítulo 4

Análisis Dinámico Formulación Euler-Lagrange

4.1. Introducción

La dinámica del Robot Hexa es considerada nuevamente dentro de este capítulo, donde, al igual que en el capítulo anterior, se desea determinar los torques aplicados por los actuadores en los eslabones de entrada para que el efector final alcance una trayectoria dada.

A diferencia del método de Newton-Euler, el método de Euler-Lagrange no contiene en sus ecuaciones todas las fuerzas de restricción entre eslabones, obteniéndose así ecuaciones de una forma cerrada. El método de Lagrange, en otras palabras, formula ecuaciones de movimiento usando un conjunto de coordenadas generalizadas (Spong, y otros, 1989). Esto permite eliminar todas o algunas de las fuerzas de restricción y permite manejar desplazamientos lineales como angulares con un solo tipo de coordenadas.

Con el entendimiento de la dinámica del manipulador, es posible diseñar un controlador con mejores características de ejecución que las realizadas con los típicos encontrados usando métodos heurísticos después de que ha sido construido el manipulador.

La función Lagrangiana es definida como la diferencia entre la energía cinética y energía potencial de un sistema mecánico como:

$$L = K - U \quad (4.1)$$

Donde K es la energía cinética definida como:

$$K = \frac{1}{2} (m \mathbf{v}^T \mathbf{v} + \boldsymbol{\omega}^T \mathbf{I} \boldsymbol{\omega}) \quad (4.2)$$

Y la energía potencial como:

$$U = -m \mathbf{g}^T \mathbf{r}_G \quad (4.3)$$

La energía cinética depende de la localización y la velocidad de los eslabones del manipulador, mientras la energía potencial depende únicamente de la localización de los eslabones. La ecuación de Lagrange de movimiento es formulada en términos de la función Lagrangiana como:

$$\frac{d}{dt} \left(\frac{\partial L}{\partial \dot{q}_j} \right) - \frac{\partial L}{\partial q_j} = Q_j \quad (4.4)$$

El término Q_j es conocido como fuerzas generalizadas y se obtendrá a partir de expresiones, que involucren los torques y coordenadas generalizadas. Cabe mencionar que no se consideran elementos disipativos debido a que en el diseño mecánico del robot se pretende colocar rodamientos, los cuales reducen los efectos disipativos en la ecuación.

4.2. Velocidad de Centros de Gravedad y Velocidad Angular

Se puede ver que en la ec. (4.2) aparece la velocidad de centro de gravedad y la velocidad angular de cada cuerpo. Dichas velocidades fueron calculadas en el análisis dinámico de Newton-Euler y serán utilizadas en el presente capítulo.



Figura 4.1. Vectores de centros de gravedad

Los vectores que se muestran en la Figura 4.1. Vectores de centros de gravedad que se encuentran definidos en la base inercial, son:

$$\begin{aligned} \mathbf{r}_{G1i}^0 &= \mathbf{r}_{1i}^0 + \mathbf{r}_{G1i'}^0 \\ \mathbf{r}_{G2i}^0 &= \mathbf{r}_{1i}^0 + \mathbf{r}_{4i}^0 + \mathbf{r}_{G2i'}^0 \\ \mathbf{r}_{G3i}^0 &= \mathbf{r}_{1i}^0 + \mathbf{r}_{4i}^0 + \mathbf{r}_{6i}^0 + \mathbf{r}_{G3i'}^0 \\ \mathbf{r}_{Gp}^0 &= \mathbf{r}_p^0 + \mathbf{r}_{Gp'}^0 \\ \mathbf{r}_{Gc}^0 &= \mathbf{r}_p^0 + \mathbf{r}_{Gc'}^0 \end{aligned}$$

En las secciones 3.2.1, 3.2.2, 3.2.3 y 3.2.4 se muestra como se construyó cada uno de los vectores anteriores.

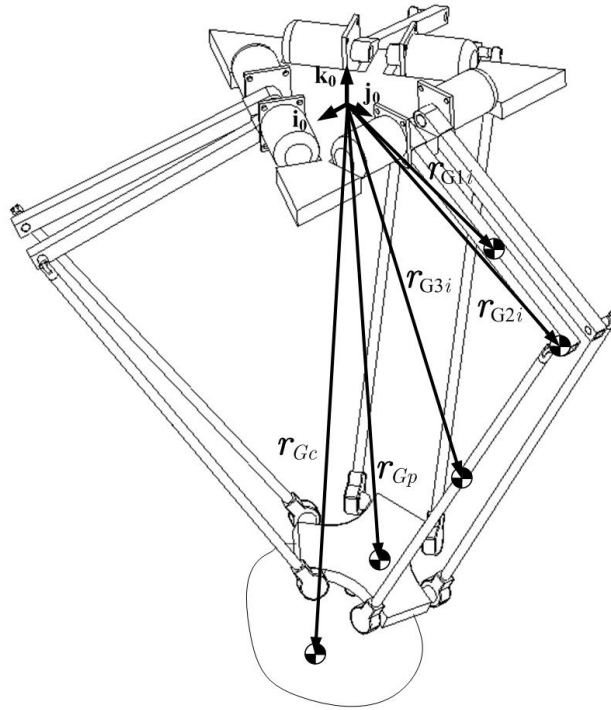
4.2.1. Velocidad de Centro de Gravedad del Cuerpo 1i

De la ec. (3.12) se tiene:

$$\mathbf{v}_{G1i}^{4i} = \boldsymbol{\omega}_{O1i}^{4i} \times \mathbf{r}_{G1i'}^{4i}$$

A partir de la ec. (3.10):

$$\begin{aligned} \boldsymbol{\omega}_{O1i}^{4i} &= \boldsymbol{\omega}_{1i}^{4i} = \dot{\theta}_{4i} \mathbf{j}_{4i}^{4i} \\ \mathbf{r}_{G1i'}^{4i} &= [x_{G1i'}, y_{G1i'}, z_{G1i'}] \end{aligned}$$

Sustituyendo en la ecuación anterior:

$$\begin{aligned} \mathbf{v}_{G1i}^{4i} &= (\dot{\theta}_{4i} \mathbf{j}_{4i}^{4i}) \times \mathbf{r}_{G1i'}^{4i} \\ &= (\mathbf{j}_{4i}^{4i} \times \mathbf{r}_{G1i'}^{4i}) \dot{\theta}_{4i} \end{aligned}$$

Ahora haciendo cambio de variable:

$$\mathbf{v}_{G1i}^{4i} = \mathbf{k}_{1i} \dot{\theta}_{4i} \quad (4.5)$$

Donde:

$$\mathbf{k}_{1i} = \mathbf{j}_{4i}^{4i} \times \mathbf{r}_{G1i'}^{4i} \quad (4.6)$$

De la ec. (2.40):

$$\dot{\theta}_{4i} = \frac{1}{V_{1i}} (V_{2i} \dot{x}_p + V_{3i} \dot{y}_p + V_{4i} \dot{z}_p + V_{5i} \dot{\psi} + V_{6i} \dot{\theta} + V_{7i} \dot{\phi})$$

Renombrando:

$$\dot{\theta}_{4i} = \mathbf{k}_{2i}^T \dot{\mathbf{q}} \quad (4.7)$$

Donde:

$$\begin{aligned} \mathbf{k}_{2i}^T &= \frac{1}{V_{1i}} [V_{2i}, V_{3i}, V_{4i}, V_{5i}, V_{6i}, V_{7i}] \\ \dot{\mathbf{q}} &= [\dot{x}_p, \dot{y}_p, \dot{z}_p, \dot{\psi}, \dot{\theta}, \dot{\phi}]^T \end{aligned} \quad (4.8)$$

Sustituyendo la ec. (4.7) en la ec. (4.5) con el fin de poner a esta última en función de las coordenadas generalizadas se tiene:

$$\begin{aligned} \mathbf{v}_{G1i}^{4i} &= \mathbf{k}_{1i} (\mathbf{k}_{2i}^T \dot{\mathbf{q}}) \\ &= (\mathbf{k}_{1i} \mathbf{k}_{2i}^T) \dot{\mathbf{q}} \end{aligned}$$

Renombrando:

$$\mathbf{v}_{G1i}^{4i} = \mathbf{M}_{1i} \dot{\mathbf{q}} \quad (4.9)$$

Donde:

$$\mathbf{M}_{1i} = \mathbf{k}_{1i} \mathbf{k}_{2i}^T \quad (4.10)$$

4.2.2. Velocidad Angular del Cuerpo 1i

De la ec. (3.10) se tiene:

$$\omega_{01i}^{4i} = \dot{\theta}_{4i} \mathbf{j}_{4i}^{4i}$$

Sustituyendo (4.7) en la ec. anterior:

$$\begin{aligned} \omega_{01i}^{4i} &= \mathbf{j}_{4i}^{4i} \dot{\theta}_{4i} = \mathbf{j}_{4i}^{4i} (\mathbf{k}_{2i}^T \dot{\mathbf{q}}) \\ &= (\mathbf{j}_{4i}^{4i} \mathbf{k}_{2i}^T) \dot{\mathbf{q}} \end{aligned}$$

Renombrando:

$$\omega_{01i}^{4i} = \mathbf{M}_{2i} \dot{\mathbf{q}} \quad (4.11)$$

Donde:

$$\mathbf{M}_{2i} = \mathbf{j}_{4i}^{4i} \mathbf{k}_{2i}^T \quad (4.12)$$

4.2.3. Velocidad de Centro de Gravedad del Cuerpo 2i

De la ec. (3.25) se tiene:

$$\mathbf{v}_{G2i}^{6i} = \omega_{01i}^{6i} \times \mathbf{r}_{4i}^{6i} + \omega_{02i}^{6i} \times \mathbf{r}_{G2i'}^{6i}$$

Donde a partir de las ecs. (3.23), (3.27) y (3.20) se tienen respectivamente los vectores de velocidad angular:

$$\begin{aligned} \omega_{01i}^{6i} &= \mathbf{R}_{4i}^{6i} \omega_{1i}^{4i} & \mathbf{r}_{4i}^{6i} &= \mathbf{R}_{4i}^{6i} \mathbf{r}_{4i}^{4i} \\ \omega_{02i}^{6i} &= \mathbf{R}_{4i}^{6i} \omega_{1i}^{4i} + \mathbf{R}_{8i}^{6i} \omega_{2i}^{8i} & \mathbf{r}_{4i}^{4i} &= [x_{5i}, 0, 0]^T \\ &= \mathbf{R}_{4i}^{6i} \omega_{1i}^{4i} + \omega_{2i}^{6i} & \mathbf{r}_{G2i'}^{6i} &= [x_{G2i'}, y_{G2i'}, z_{G2i'}]^T \\ \omega_{2i}^{6i} &= \dot{\theta}_{8i} \mathbf{i}_{6i}^{6i} & \mathbf{R}_{4i}^{6i} &= \mathbf{R}_{26} (-\delta_{6i}) \end{aligned}$$

Sustituyendo los términos de velocidad angular anteriores en la ecuación (3.25) y simplificando:

$$\begin{aligned} \mathbf{v}_{G2i}^{6i} &= (\mathbf{R}_{4i}^{6i} \omega_{1i}^{4i}) \times \mathbf{R}_{4i}^{6i} \mathbf{r}_{4i}^{4i} + (\mathbf{R}_{4i}^{6i} \omega_{1i}^{4i} + \omega_{2i}^{6i}) \times \mathbf{r}_{G2i'}^{6i} \\ &= \mathbf{R}_{4i}^{6i} (\dot{\theta}_{4i} \mathbf{j}_{4i}^{4i} \times \mathbf{r}_{4i}^{4i}) + (\mathbf{R}_{4i}^{6i} (\dot{\theta}_{4i} \mathbf{j}_{4i}^{4i}) + \dot{\theta}_{8i} \mathbf{i}_{6i}^{6i}) \times \mathbf{r}_{G2i'}^{6i} \\ &= \mathbf{R}_{4i}^{6i} (\dot{\theta}_{4i} \mathbf{j}_{4i}^{4i} \times \mathbf{r}_{4i}^{4i}) + (\dot{\theta}_{4i} \mathbf{j}_{4i}^{6i} + \dot{\theta}_{8i} \mathbf{i}_{6i}^{6i}) \times \mathbf{r}_{G2i'}^{6i} \\ &= \mathbf{R}_{4i}^{6i} (\mathbf{j}_{4i}^{4i} \times \mathbf{r}_{4i}^{4i}) \dot{\theta}_{4i} \end{aligned}$$

Donde $\mathbf{j}_{4i}^{6i} = -\mathbf{i}_{6i}^{6i}$. Haciendo un cambio de variable se tiene:

$$\mathbf{v}_{G2i}^{6i} = \mathbf{k}_{3i} \dot{\theta}_{4i} \quad (4.13)$$

Donde:

$$\mathbf{k}_{3i} = \mathbf{R}_{4i}^{6i} (\mathbf{j}_{4i}^{4i} \times \mathbf{r}_{4i}^{4i}) \quad (4.14)$$

Sustituyendo la ec. (4.7) en la ec. (4.13) con el fin de poner a esta última en función de las coordenadas generalizadas se tiene:

$$\begin{aligned} \mathbf{v}_{G2i}^{6i} &= \mathbf{k}_{3i} (\mathbf{k}_{2i}^T \dot{\mathbf{q}}) \\ &= (\mathbf{k}_{3i} \mathbf{k}_{2i}^T) \dot{\mathbf{q}} \end{aligned}$$

Finalmente renombrando:

$$v_{G2i}^{6i} = M_{3i} \dot{q} \quad (4.15)$$

Donde:

$$M_{3i} = k_{3i} k_{2i}^T \quad (4.16)$$

3.2.4. Velocidad Angular del Cuerpo 2i

De la ec. (3.23) se tiene

$$\omega_{O2i}^{6i} = R_{4i}^{6i} \omega_{1i}^{4i} + \omega_{2i}^{6i}$$

Ahora con el fin de obtener los términos ω_{1i}^{4i} y ω_{2i}^{6i} se tiene de la ec. (3.10):

$$\omega_{1i}^{4i} = \omega_{O1i}^{4i}$$

Se sabe de la ec. (4.11) que:

$$\omega_{O1i}^{4i} = M_{2i} \dot{q}$$

De la ec. (3.20):

$$\omega_{2i}^{6i} = i_{6i}^{6i} \dot{\theta}_{8i}$$

Ahora de la ec. (2.46):

$$\dot{\theta}_{8i} = \frac{1}{V_{8i}} (E_{1i} \dot{x}_p + E_{2i} \dot{y}_p + E_{3i} \dot{z}_p + E_{4i} \dot{\psi} + E_{5i} \dot{\theta} + E_{6i} \dot{\phi})$$

Renombrando:

$$\dot{\theta}_{8i} = k_{4i}^T \dot{q} \quad (4.17)$$

Donde:

$$k_{4i}^T = \frac{1}{V_{8i}} [E_{1i}, E_{2i}, E_{3i}, E_{4i}, E_{5i}, E_{6i}] \quad (4.18)$$

Sustituyendo la ec. (4.17) en la ecuación (3.20):

$$\begin{aligned} \omega_{2i}^{6i} &= i_{6i}^{6i} (k_{4i}^T \dot{q}) \\ &= (i_{6i}^{6i} k_{4i}^T) \dot{q} \end{aligned}$$

Haciendo cambio de variable:

$$\omega_{2i}^{6i} = M_{4i} \dot{q} \quad (4.19)$$

Donde:

$$M_{4i} = i_{6i}^{6i} k_{4i}^T \quad (4.20)$$

Sustituyendo las ecs. (4.11) y (4.19) en (3.23) y simplificando:

$$\begin{aligned} \omega_{O2i}^{6i} &= R_{4i}^{6i} (M_{2i} \dot{q}) + M_{4i} \dot{q} \\ &= (R_{4i}^{6i} M_{2i} + M_{4i}) \dot{q} \end{aligned}$$

Renombrando:

$$\omega_{O2i}^{6i} = M_{5i} \dot{q} \quad (4.21)$$

Donde:

$$M_{5i} = R_{4i}^{6i} M_{2i} + M_{4i} \quad (4.22)$$

3.2.5. Velocidad de Centro de Gravedad del Cuerpo 3i

De la ec. (3.39):

$$\mathbf{v}_{G3i}^{9i} = \boldsymbol{\omega}_{O1i}^{9i} \times \mathbf{r}_{4i}^{9i} + \boldsymbol{\omega}_{O2i}^{9i} \times \mathbf{r}_{6i}^{9i} + \boldsymbol{\omega}_{O3i}^{9i} \times \mathbf{r}_{G3i'}^{9i}$$

Donde a partir de las ecs. (3.42) y (3.37):

$$\begin{aligned} \boldsymbol{\omega}_{O1i}^{9i} &= R_{4i}^{9i} \boldsymbol{\omega}_{1i}^{4i} \\ \boldsymbol{\omega}_{O2i}^{9i} &= R_{4i}^{9i} \boldsymbol{\omega}_{1i}^{4i} + R_{8i}^{9i} \boldsymbol{\omega}_{2i}^{8i} \\ \boldsymbol{\omega}_{O3i}^{9i} &= R_{4i}^{9i} \boldsymbol{\omega}_{1i}^{4i} + R_{8i}^{9i} \boldsymbol{\omega}_{2i}^{8i} + \boldsymbol{\omega}_{3i}^{9i} \end{aligned}$$

$$\begin{aligned} \mathbf{r}_{4i}^{9i} &= R_{4i}^{9i} \mathbf{r}_{4i}^{4i} \\ \mathbf{r}_{6i}^{9i} &= R_{6i}^{9i} \mathbf{r}_{6i}^{6i} \\ \mathbf{r}_{6i}^{6i} &= [x_7, 0, 0] \\ \mathbf{r}_{G3i'}^{9i} &= [x_{G3i'}, y_{G3i'}, z_{G3i'}] \end{aligned}$$

$$\begin{aligned} R_{4i}^{9i} &= R_{z5}(-\theta_{9i}) R_{z4}(-\theta_{8i}) R_{z6}(-\delta_{6i}) \\ R_{6i}^{9i} &= R_{z5}(-\theta_{9i}) R_{z4}(-\theta_{8i}) \\ R_{8i}^{9i} &= R_{z5}(-\theta_{9i}) \end{aligned}$$

Sustituyendo los términos de velocidad angular anteriores en la ecuación (3.39) y simplificando:

$$\begin{aligned} \mathbf{v}_{G3i}^{9i} &= (R_{4i}^{9i} \boldsymbol{\omega}_{1i}^{4i}) \times \mathbf{r}_{4i}^{9i} + (R_{4i}^{9i} \boldsymbol{\omega}_{1i}^{4i} + R_{8i}^{9i} \boldsymbol{\omega}_{2i}^{8i}) \times \mathbf{r}_{6i}^{9i} + (R_{4i}^{9i} \boldsymbol{\omega}_{1i}^{4i} + R_{8i}^{9i} \boldsymbol{\omega}_{2i}^{8i} + \boldsymbol{\omega}_{3i}^{9i}) \times \mathbf{r}_{G3i'}^{9i} \\ &= R_{4i}^{9i} \boldsymbol{\omega}_{1i}^{4i} \times (\mathbf{r}_{4i}^{9i} + \mathbf{r}_{6i}^{9i} + \mathbf{r}_{G3i'}^{9i}) + R_{8i}^{9i} \boldsymbol{\omega}_{2i}^{8i} \times (\mathbf{r}_{6i}^{9i} + \mathbf{r}_{G3i'}^{9i}) + \boldsymbol{\omega}_{3i}^{9i} \times \mathbf{r}_{G3i'}^{9i} \\ &= R_{4i}^{9i} \boldsymbol{\omega}_{1i}^{4i} \times (\mathbf{r}_{4i}^{9i} + \mathbf{r}_{G3i'}^{9i}) + R_{8i}^{9i} \boldsymbol{\omega}_{2i}^{8i} \times \mathbf{r}_{G3i'}^{9i} + \boldsymbol{\omega}_{3i}^{9i} \times \mathbf{r}_{G3i'}^{9i} \end{aligned}$$

Donde, de las ecs. (3.7), (3.20) y (3.34) se tienen los términos de velocidad angular:

$$\begin{aligned} \boldsymbol{\omega}_{1i}^{4i} &= \dot{\theta}_{4i} \mathbf{j}_{4i}^{4i} \\ \boldsymbol{\omega}_{2i}^{8i} &= \dot{\theta}_{8i} \mathbf{i}_{8i}^{8i} \\ \boldsymbol{\omega}_{3i}^{9i} &= \dot{\theta}_{9i} \mathbf{j}_{9i}^{9i} \end{aligned}$$

Ahora sustituyendo los términos de velocidad angular en la ecuación anterior y simplificando:

$$\begin{aligned} \mathbf{v}_{G3i}^{9i} &= R_{4i}^{9i} (\mathbf{j}_{4i}^{4i} \dot{\theta}_{4i}) \times (\mathbf{r}_{4i}^{9i} + \mathbf{r}_{G3i'}^{9i}) + R_{8i}^{9i} (\mathbf{i}_{8i}^{8i} \dot{\theta}_{8i}) \times \mathbf{r}_{G3i'}^{9i} + (\mathbf{j}_{9i}^{9i} \dot{\theta}_{9i}) \times \mathbf{r}_{G3i'}^{9i} \\ &= (R_{4i}^{9i} \mathbf{j}_{4i}^{4i} \times (\mathbf{r}_{4i}^{9i} + \mathbf{r}_{G3i'}^{9i})) \dot{\theta}_{4i} + (R_{8i}^{9i} \mathbf{i}_{8i}^{8i} \times \mathbf{r}_{G3i'}^{9i}) \dot{\theta}_{8i} + (\mathbf{j}_{9i}^{9i} \times \mathbf{r}_{G3i'}^{9i}) \dot{\theta}_{9i} \end{aligned}$$

Renombrando:

$$\mathbf{v}_{G3i}^{9i} = \mathbf{k}_{5i} \dot{\theta}_{4i} + \mathbf{k}_{6i} \dot{\theta}_{8i} + \mathbf{k}_{7i} \dot{\theta}_{9i} \quad (4.23)$$

Donde:

$$\begin{aligned} \mathbf{k}_{5i} &= \mathbf{R}_{4i}^{9i} \mathbf{J}_{4i}^{4i} \times (\mathbf{r}_{4i}^{9i} + \mathbf{r}_{G3i'}^{9i}) \\ \mathbf{k}_{6i} &= \mathbf{R}_{8i}^{9i} \mathbf{J}_{8i}^{8i} \times \mathbf{r}_{G3i'}^{9i} \\ \mathbf{k}_{7i} &= \mathbf{j}_{9i}^{9i} \times \mathbf{r}_{G3i'}^{9i} \end{aligned} \quad (4.24)$$

Ahora de la ec. (2.51):

$$\dot{\theta}_{9i} = \frac{1}{V_{16i}} (E_{7i} \dot{x}_p + E_{8i} \dot{y}_p + E_{9i} \dot{z}_p + E_{10i} \dot{\psi} + E_{11i} \dot{\theta} + E_{12i} \dot{\phi})$$

Renombrando:

$$\dot{\theta}_{9i} = \mathbf{k}_{8i}^T \dot{\mathbf{q}} \quad (4.25)$$

Donde:

$$\mathbf{k}_{8i}^T = \frac{1}{V_{16i}} [E_{7i}, E_{8i}, E_{9i}, E_{10i}, E_{11i}, E_{12i}] \quad (4.26)$$

Ahora sustituyendo las ecs. (4.7), (4.17) y (4.25) en (4.23) con el fin de poner a esta última en función de las coordenadas generalizadas se tiene:

$$\begin{aligned} \mathbf{v}_{G3i}^{9i} &= \mathbf{k}_{5i} \mathbf{k}_{2i}^T \dot{\mathbf{q}} + \mathbf{k}_{6i} \mathbf{k}_{4i}^T \dot{\mathbf{q}} + \mathbf{k}_{7i} \mathbf{k}_{8i}^T \dot{\mathbf{q}} \\ &= (\mathbf{k}_{5i} \mathbf{k}_{2i}^T + \mathbf{k}_{6i} \mathbf{k}_{4i}^T + \mathbf{k}_{7i} \mathbf{k}_{8i}^T) \dot{\mathbf{q}} \end{aligned}$$

Por último, renombrando:

$$\mathbf{v}_{G3i}^{9i} = \mathbf{M}_{6i} \dot{\mathbf{q}} \quad (4.27)$$

Donde:

$$\mathbf{M}_{6i} = \mathbf{k}_{5i} \mathbf{k}_{2i}^T + \mathbf{k}_{6i} \mathbf{k}_{4i}^T + \mathbf{k}_{7i} \mathbf{k}_{8i}^T \quad (4.28)$$

3.2.6. Velocidad Angular del Cuerpo 3i

De la ec. (3.37):

$$\boldsymbol{\omega}_{O3i}^{9i} = \mathbf{R}_{4i}^{9i} \boldsymbol{\omega}_{1i}^{4i} + \mathbf{R}_{8i}^{9i} \boldsymbol{\omega}_{2i}^{8i} + \boldsymbol{\omega}_{3i}^{9i}$$

Ahora con el fin de obtener solo el término $\boldsymbol{\omega}_{3i}^{9i}$, ya que los términos $\boldsymbol{\omega}_{1i}^{4i}$ y $\boldsymbol{\omega}_{2i}^{8i}$ se calcularon anteriormente, se tiene de la ec. (3.34):

$$\boldsymbol{\omega}_{3i}^{9i} = \mathbf{j}_{9i}^{9i} \dot{\theta}_{9i}$$

Sustituyendo la ec. (4.25) en la ec. anterior se tiene:

$$\begin{aligned} \boldsymbol{\omega}_{3i}^{9i} &= \mathbf{j}_{9i}^{9i} \dot{\theta}_{9i} \\ &= (\mathbf{j}_{9i}^{9i} \mathbf{k}_{8i}^T) \dot{\mathbf{q}} \end{aligned}$$

Haciendo cambio de variable:

$$\boldsymbol{\omega}_{3i}^{9i} = \mathbf{M}_{7i} \dot{\mathbf{q}} \quad (4.29)$$

Donde:

$$\mathbf{M}_{7i} = \mathbf{j}_{9i}^{9i} \mathbf{k}_{8i}^T \quad (4.30)$$

Finalmente sustituyendo las ecs. (4.11), (4.19) y (4.29) en (3.37) y simplificando, se tiene:

$$\begin{aligned}\omega_{O3i}^{9i} &= \mathbf{R}_{4i}^{9i} \omega_{1i}^{4i} + \mathbf{R}_{8i}^{9i} \omega_{2i}^{8i} + \omega_{3i}^{9i} \\ &= \mathbf{R}_{4i}^{9i} \mathbf{M}_{2i} \dot{\mathbf{q}} + \mathbf{R}_{8i}^{9i} \mathbf{M}_{4i} \dot{\mathbf{q}} + \mathbf{M}_{7i} \dot{\mathbf{q}} \\ &= (\mathbf{R}_{4i}^{9i} \mathbf{M}_{2i} + \mathbf{R}_{8i}^{9i} \mathbf{M}_{4i} + \mathbf{M}_{7i}) \dot{\mathbf{q}}\end{aligned}$$

Renombrando:

$$\omega_{O3i}^{9i} = \mathbf{M}_{8i} \dot{\mathbf{q}} \quad (4.31)$$

Donde:

$$\mathbf{M}_{8i} = \mathbf{R}_{4i}^{9i} \mathbf{M}_{2i} + \mathbf{R}_{8i}^{9i} \mathbf{M}_{4i} + \mathbf{M}_{7i} \quad (4.32)$$

3.2.7. Velocidad de Centro de Gravedad del Plato Móvil

De la ec. (3.62):

$$\mathbf{v}_{Gp}^p = \mathbf{R}_0^p \mathbf{v}_p^0 + \omega_{Op}^p \times \mathbf{r}_{Gp}^p$$

Donde, de las ecs. (3.60) y (3.49), se tienen los vectores de velocidad angular y lineal respectivamente:

$$\begin{aligned}\omega_{Op}^p &= \mathbf{R}_0^p \omega_\psi^0 + \mathbf{R}_{18}^p \omega_\theta^{18} + \mathbf{R}_{19}^p \omega_\phi^{19} \\ \mathbf{v}_p^0 &= [\dot{x}_p, \dot{y}_p, \dot{z}_p]^T\end{aligned}$$

$$\begin{aligned}\mathbf{R}_0^p &= \mathbf{R}_{z6} (-\phi) \mathbf{R}_{z4} (-\theta) \mathbf{R}_{z6} (-\psi) \\ \mathbf{r}_{Gp}^p &= [x_{Gp}, y_{Gp}, z_{Gp}]^T\end{aligned}$$

Sustituyendo la ec. (3.60) y agrupando:

$$\begin{aligned}\mathbf{v}_{Gp}^p &= \mathbf{R}_0^p \mathbf{v}_p^0 + (\mathbf{R}_0^p \omega_\psi^0 + \mathbf{R}_{18}^p \omega_\theta^{18} + \mathbf{R}_{19}^p \omega_\phi^{19}) \times \mathbf{r}_{Gp}^p \\ \mathbf{v}_{Gp}^p &= \mathbf{R}_0^p \mathbf{v}_p^0 + \mathbf{R}_0^p \omega_\psi^0 \times \mathbf{r}_{Gp}^p + \mathbf{R}_{18}^p \omega_\theta^{18} \times \mathbf{r}_{Gp}^p + \mathbf{R}_{19}^p \omega_\phi^{19} \times \mathbf{r}_{Gp}^p\end{aligned}$$

Donde, de las ecs. (3.51), se tienen los vectores locales de velocidad angular:

$$\begin{aligned}\omega_\psi^0 &= \dot{\psi} \mathbf{k}_0^0 \\ \omega_\theta^{18} &= \dot{\theta} \mathbf{i}_{18}^{18} \\ \omega_\phi^{19} &= \dot{\phi} \mathbf{k}_{19}^{19}\end{aligned}$$

$$\begin{aligned}\mathbf{R}_{18}^p &= \mathbf{R}_{z6} (-\phi) \mathbf{R}_{z4} (-\theta) \\ \mathbf{R}_{19}^p &= \mathbf{R}_{z6} (-\phi)\end{aligned}$$

Ahora sustituyendo los términos de velocidad angular de las ecs. (3.51) en la ecuación anterior y simplificando:

$$\begin{aligned}\mathbf{v}_{Gp}^p &= \mathbf{R}_0^p \mathbf{v}_p^0 + \mathbf{R}_0^p \omega_\psi^0 \times \mathbf{r}_{Gp}^p + \mathbf{R}_{18}^p \omega_\theta^{18} \times \mathbf{r}_{Gp}^p + \mathbf{R}_{19}^p \omega_\phi^{19} \times \mathbf{r}_{Gp}^p \\ \mathbf{v}_{Gp}^p &= \mathbf{R}_0^p \mathbf{v}_p^0 + \mathbf{R}_0^p (\mathbf{k}_0^0 \dot{\psi}) \times \mathbf{r}_{Gp}^p + \mathbf{R}_{18}^p (\mathbf{i}_{18}^{18} \dot{\theta}) \times \mathbf{r}_{Gp}^p + (\mathbf{k}_{19}^{19} \dot{\phi}) \times \mathbf{r}_{Gp}^p \\ \mathbf{v}_{Gp}^p &= \mathbf{R}_0^p \mathbf{v}_p^0 + (\mathbf{R}_0^p \mathbf{k}_0^0 \times \mathbf{r}_{Gp}^p) \dot{\psi} + (\mathbf{R}_{18}^p \mathbf{i}_{18}^{18} \times \mathbf{r}_{Gp}^p) \dot{\theta} + (\mathbf{k}_{19}^{19} \times \mathbf{r}_{Gp}^p) \dot{\phi}\end{aligned}$$

Renombrando:

$$\mathbf{v}_{Gp}^p = \mathbf{R}_0^p \mathbf{v}_p^0 + \mathbf{k}_9 \dot{\psi} + \mathbf{k}_{10} \dot{\theta} + \mathbf{k}_{11} \dot{\phi} \quad (4.33)$$

Donde:

$$\begin{aligned} \mathbf{k}_9 &= \mathbf{R}_0^p \mathbf{k}_0^0 \times \mathbf{r}_{Gp}^p, \\ \mathbf{k}_{10} &= \mathbf{R}_{18}^p \mathbf{i}_{18}^{18} \times \mathbf{r}_{Gp}^p, \\ \mathbf{k}_{11} &= \mathbf{k}_{19}^{19} \times \mathbf{r}_{Gp}^p \end{aligned} \quad (4.34)$$

Ahora poniendo en función de las coordenadas generalizadas a la ec. (4.33) se tiene:

$$\mathbf{v}_{Gp}^p = [\mathbf{R}_0^p, \mathbf{k}_9, \mathbf{k}_{10}, \mathbf{k}_{11}] \dot{\mathbf{q}}$$

Renombrando:

$$\mathbf{v}_{Gp}^p = \mathbf{M}_9 \dot{\mathbf{q}} \quad (4.35)$$

Donde:

$$\begin{aligned} \mathbf{M}_9 &= [\mathbf{R}_0^p, \mathbf{k}_9, \mathbf{k}_{10}, \mathbf{k}_{11}] \\ \dot{\mathbf{q}} &= [\mathbf{v}_p^0, \dot{\psi}, \dot{\theta}, \dot{\phi}]^T \end{aligned} \quad (4.36)$$

3.2.8. Velocidad Angular del Plato Móvil

De la ec. (3.60):

$$\boldsymbol{\omega}_{Op}^p = \mathbf{R}_0^p \boldsymbol{\omega}_\psi^0 + \mathbf{R}_{18}^p \boldsymbol{\omega}_\theta^{18} + \mathbf{R}_{19}^p \boldsymbol{\omega}_\phi^{19}$$

Ahora sustituyendo los términos de velocidad angular de las ecs. (3.51) en la ecuación anterior:

$$\begin{aligned} \boldsymbol{\omega}_{Op}^p &= \mathbf{R}_0^p \boldsymbol{\omega}_\psi^0 + \mathbf{R}_{18}^p \boldsymbol{\omega}_\theta^{18} + \mathbf{R}_{19}^p \boldsymbol{\omega}_\phi^{19} \\ \boldsymbol{\omega}_{Op}^p &= (\mathbf{R}_0^p \mathbf{k}_0^0) \dot{\psi} + (\mathbf{R}_{18}^p \mathbf{i}_{18}^{18}) \dot{\theta} + \mathbf{k}_{19}^{19} \dot{\phi} \end{aligned}$$

Renombrando:

$$\boldsymbol{\omega}_{Op}^p = \mathbf{k}_{12} \dot{\psi} + \mathbf{k}_{13} \dot{\theta} + \mathbf{k}_{14} \dot{\phi} \quad (4.37)$$

Donde:

$$\begin{aligned} \mathbf{k}_{12} &= \mathbf{R}_0^p \mathbf{k}_0^0 \\ \mathbf{k}_{13} &= \mathbf{R}_{18}^p \mathbf{i}_{18}^{18} \\ \mathbf{k}_{14} &= \mathbf{k}_{19}^{19} \end{aligned} \quad (4.38)$$

Finalmente poniendo en función de las coordenadas generalizadas:

$$\begin{aligned} \boldsymbol{\omega}_{Op}^p &= [\mathbf{0}, \mathbf{0}, \mathbf{0}, \mathbf{k}_{12}, \mathbf{k}_{13}, \mathbf{k}_{14}] \dot{\mathbf{q}} \\ \boldsymbol{\omega}_{Op}^p &= \mathbf{M}_{10} \dot{\mathbf{q}} \end{aligned} \quad (4.39)$$

Donde:

$$\begin{aligned} \mathbf{M}_{10} &= [\mathbf{0}, \mathbf{0}, \mathbf{0}, \mathbf{k}_{12}, \mathbf{k}_{13}, \mathbf{k}_{14}] \\ \mathbf{0} &= [0, 0, 0]^T \end{aligned} \quad (4.40)$$

3.2.9. Velocidad de Centro de Gravedad de la Carga

De la ec. (3.64):

$$\mathbf{v}_{Gc}^p = \mathbf{R}_0^p \mathbf{v}_p^0 + \boldsymbol{\omega}_{Oc}^p \times \mathbf{r}_{Gc'}^p$$

Donde, de la ec. (3.57) se tiene el vector de velocidad angular:

$$\begin{aligned} \boldsymbol{\omega}_{Oc}^p &= \mathbf{R}_0^p \boldsymbol{\omega}_\psi^0 + \mathbf{R}_{18}^p \boldsymbol{\omega}_\theta^{18} + \boldsymbol{\omega}_\phi^{19} \\ \mathbf{r}_{Gc'}^p &= [x_{Gc}, y_{Gc}, z_{Gc}]^T \end{aligned}$$

Sustituyendo la ec. de velocidad angular anterior en la ec. (3.64) y agrupando:

$$\begin{aligned} \mathbf{v}_{Gc}^p &= \mathbf{R}_0^p \mathbf{v}_p^0 + (\mathbf{R}_0^p \boldsymbol{\omega}_\psi^0 + \mathbf{R}_{18}^p \boldsymbol{\omega}_\theta^{18} + \boldsymbol{\omega}_\phi^{19}) \times \mathbf{r}_{Gc'}^p \\ \mathbf{v}_{Gc}^p &= \mathbf{R}_0^p \mathbf{v}_p^0 + \mathbf{R}_0^p \boldsymbol{\omega}_\psi^0 \times \mathbf{r}_{Gc'}^p + \mathbf{R}_{18}^p \boldsymbol{\omega}_\theta^{18} \times \mathbf{r}_{Gc'}^p + \boldsymbol{\omega}_\phi^{19} \times \mathbf{r}_{Gc'}^p \end{aligned}$$

Ahora sustituyendo los términos de velocidad angular y simplificando:

$$\begin{aligned} \mathbf{v}_{Gc}^p &= \mathbf{R}_0^p \mathbf{v}_p^0 + \mathbf{R}_0^p (\mathbf{k}_0^0 \dot{\psi}) \times \mathbf{r}_{Gc'}^p + \mathbf{R}_{18}^p (\mathbf{i}_{18}^{18} \dot{\theta}) \times \mathbf{r}_{Gc'}^p + (\mathbf{k}_{19}^{19} \dot{\phi}) \times \mathbf{r}_{Gc'}^p \\ \mathbf{v}_{Gc}^p &= \mathbf{R}_0^p \mathbf{v}_p^0 + (\mathbf{R}_0^p \mathbf{k}_0^0 \times \mathbf{r}_{Gc'}^p) \dot{\psi} + (\mathbf{R}_{18}^p \mathbf{i}_{18}^{18} \times \mathbf{r}_{Gc'}^p) \dot{\theta} + (\mathbf{k}_{19}^{19} \times \mathbf{r}_{Gc'}^p) \dot{\phi} \end{aligned}$$

Renombrando:

$$\mathbf{v}_{Gc}^p = \mathbf{R}_0^p \mathbf{v}_p^0 + \mathbf{k}_{15} \dot{\psi} + \mathbf{k}_{16} \dot{\theta} + \mathbf{k}_{17} \dot{\phi} \quad (4.41)$$

Donde:

$$\begin{aligned} \mathbf{k}_{15} &= \mathbf{R}_0^p \mathbf{k}_0^0 \times \mathbf{r}_{Gc'}^p \\ \mathbf{k}_{16} &= \mathbf{R}_{18}^p \mathbf{i}_{18}^{18} \times \mathbf{r}_{Gc'}^p \\ \mathbf{k}_{17} &= \mathbf{k}_{19}^{19} \times \mathbf{r}_{Gc'}^p \end{aligned} \quad (4.42)$$

Ahora poniendo en función de las coordenadas generalizadas a la ec. (4.41) se tiene:

$$\begin{aligned} \mathbf{v}_{Gc}^p &= \mathbf{R}_0^p \mathbf{v}_p^0 + \mathbf{k}_{15} \dot{\psi} + \mathbf{k}_{16} \dot{\theta} + \mathbf{k}_{17} \dot{\phi} \\ \mathbf{v}_{Gc}^p &= [\mathbf{R}_0^p, \mathbf{k}_{15}, \mathbf{k}_{16}, \mathbf{k}_{17}] \dot{\mathbf{q}} \end{aligned}$$

Renombrando:

$$\mathbf{v}_{Gc}^p = \mathbf{M}_{11} \dot{\mathbf{q}} \quad (4.43)$$

Donde:

$$\mathbf{M}_{11} = [\mathbf{R}_0^p, \mathbf{k}_{15}, \mathbf{k}_{16}, \mathbf{k}_{17}] \quad (4.44)$$

4.2.10. Velocidad angular de la carga

Debido a que la carga va fija al plato móvil, se tiene que la velocidad angular de la carga es igual a la del plato móvil, esto es, de la ec. (3.60):

$$\boldsymbol{\omega}_{Oc}^p = \boldsymbol{\omega}_{Op}^p = \mathbf{M}_{10} \dot{\mathbf{q}} \quad (4.45)$$

4.3. Función Lagrangiana

Aplicando la ec. (4.1) al Robot Hexa, se consigue de manera general la siguiente expresión:

$$L = \sum_{i=1}^6 \left(\sum_{k=1}^3 (K_{ki} - U_{ki}) \right) + L_p + L_c \quad (4.46)$$

i = número de la cadena

k = número de cuerpos en la cadena i

Expandiendo los términos del primer paréntesis:

$$\begin{aligned} L &= \sum_{i=1}^6 ((K_{1i} - U_{1i}) + (K_{2i} - U_{2i}) + (K_{3i} - U_{3i})) + (K_p - U_p) + (K_c - U_c) \\ L &= \sum_{i=1}^6 (L_{1i} + L_{2i} + L_{3i}) + L_p + L_c \end{aligned} \quad (4.47)$$

Donde $L_{ki} = K_{ki} - U_{ki}$:

$$\begin{aligned} L_{1i} &= \frac{1}{2} \left(m_{1i} (\mathbf{v}_{G1i}^{4i})^T \mathbf{v}_{G1i}^{4i} + (\boldsymbol{\omega}_{O1i}^{4i})^T \mathbf{J}_{G1i} \boldsymbol{\omega}_{O1i}^{4i} \right) + m_{1i} \mathbf{g}^T \mathbf{r}_{G1i}^{0i} \\ L_{2i} &= \frac{1}{2} \left(m_{2i} (\mathbf{v}_{G2i}^{6i})^T \mathbf{v}_{G2i}^{6i} + (\boldsymbol{\omega}_{O2i}^{6i})^T \mathbf{J}_{G2i} \boldsymbol{\omega}_{O2i}^{6i} \right) + m_{2i} \mathbf{g}^T \mathbf{r}_{G2i}^{0i} \\ L_{3i} &= \frac{1}{2} \left(m_{3i} (\mathbf{v}_{G3i}^{9i})^T \mathbf{v}_{G3i}^{9i} + (\boldsymbol{\omega}_{O3i}^{9i})^T \mathbf{J}_{G3i} \boldsymbol{\omega}_{O3i}^{9i} \right) + m_{3i} \mathbf{g}^T \mathbf{r}_{G3i}^{0i} \\ L_p &= \frac{1}{2} \left(m_p (\mathbf{v}_{Gp}^p)^T \mathbf{v}_{Gp}^p + (\boldsymbol{\omega}_{Op}^p)^T \mathbf{J}_{Gp} \boldsymbol{\omega}_{Op}^p \right) + m_p \mathbf{g}^T \mathbf{r}_{Gp}^0 \\ L_c &= \frac{1}{2} \left(m_c (\mathbf{v}_{Gc}^p)^T \mathbf{v}_{Gc}^p + (\boldsymbol{\omega}_{Oc}^p)^T \mathbf{J}_{Gc} \boldsymbol{\omega}_{Oc}^p \right) + m_c \mathbf{g}^T \mathbf{r}_{Gc}^0 \end{aligned}$$

Donde $\mathbf{g} = [0, 0, -9.81]^T$.

4.3.1. Desarrollo del Primer Término de la Ecuación de Lagrange

Desarrollando el Término $\frac{d}{dt} \left(\frac{\partial L}{\partial \dot{q}_j} \right)$

A partir de la ec. (4.4)

$$\frac{d}{dt} \left(\frac{\partial L}{\partial \dot{q}_j} \right) - \frac{\partial L}{\partial q_j} = Q_j$$

Desarrollando el primer término de la ecuación anterior a partir de la ec. (4.47):

$$\frac{\partial L}{\partial \dot{q}_j} = \sum_{i=1}^6 \left(\frac{\partial L_{1i}}{\partial \dot{q}_j} + \frac{\partial L_{2i}}{\partial \dot{q}_j} + \frac{\partial L_{3i}}{\partial \dot{q}_j} \right) + \frac{\partial L_p}{\partial \dot{q}_j} + \frac{\partial L_c}{\partial \dot{q}_j} \quad (4.48)$$

Para $j=1, 2, 3, 4, 5, 6$, donde:

$$\begin{aligned} \dot{q}_1 &= \dot{x}_p & \dot{q}_2 &= \dot{y}_p & \dot{q}_3 &= \dot{z}_p \\ \dot{q}_4 &= \dot{\psi} & \dot{q}_5 &= \dot{\theta} & \dot{q}_6 &= \dot{\phi} \end{aligned}$$

Desarrollando $\frac{\partial L_{1i}}{\partial \dot{q}_j}$

Tomando cada subtérmino de la ec. (4.48):

$$\frac{\partial L_{1i}}{\partial \dot{q}_j} = \frac{\partial}{\partial \dot{q}_j} \left(\frac{1}{2} \left(m_{1i} (\mathbf{v}_{G1i}^{4i})^T \mathbf{v}_{G1i}^{4i} + (\boldsymbol{\omega}_{O1i}^{4i})^T \mathbf{J}_{G1i} \boldsymbol{\omega}_{O1i}^{4i} \right) + m_{1i} \mathbf{g}^T \mathbf{r}_{G1i}^{4i} \right) \quad (4.49)$$

Sustituyendo ecs. (4.9), (4.11) en ec. (4.49) y agrupando:

$$\begin{aligned} \frac{\partial L_{1i}}{\partial \dot{q}_j} &= \frac{1}{2} \frac{\partial}{\partial \dot{q}_j} \left(m_{1i} (\mathbf{v}_{G1i}^{4i})^T \mathbf{v}_{G1i}^{4i} + (\boldsymbol{\omega}_{O1i}^{4i})^T \mathbf{J}_{G1i} \boldsymbol{\omega}_{O1i}^{4i} \right) \\ &= \frac{1}{2} \frac{\partial}{\partial \dot{q}_j} \left(m_{1i} (\mathbf{M}_{1i} \dot{\mathbf{q}})^T \mathbf{M}_{1i} \dot{\mathbf{q}} + (\mathbf{M}_{2i} \dot{\mathbf{q}})^T \mathbf{J}_{G1i} \mathbf{M}_{2i} \dot{\mathbf{q}} \right) \\ &= \frac{1}{2} \frac{\partial}{\partial \dot{q}_j} \left(m_{1i} \dot{\mathbf{q}}^T (\mathbf{M}_{1i}^T \mathbf{M}_{1i}) \dot{\mathbf{q}} + \dot{\mathbf{q}}^T (\mathbf{M}_{2i}^T \mathbf{J}_{G1i} \mathbf{M}_{2i}) \dot{\mathbf{q}} \right) \\ &= \frac{1}{2} \frac{\partial}{\partial \dot{q}_j} \left(\dot{\mathbf{q}}^T (m_{1i} \mathbf{M}_{1i}^T \mathbf{M}_{1i} + \mathbf{M}_{2i}^T \mathbf{J}_{G1i} \mathbf{M}_{2i}) \dot{\mathbf{q}} \right) \\ \frac{\partial L_{1i}}{\partial \dot{q}_j} &= \frac{1}{2} \frac{\partial}{\partial \dot{q}_j} \left(\dot{\mathbf{q}}^T \mathbf{N}_{1i} \dot{\mathbf{q}} \right) \end{aligned}$$

Efectuando la derivada:

$$\frac{\partial L_{1i}}{\partial \dot{q}_j} = \frac{1}{2} \left(\frac{\partial \dot{\mathbf{q}}^T}{\partial \dot{q}_j} \mathbf{N}_{1i} \dot{\mathbf{q}} + \dot{\mathbf{q}}^T \mathbf{N}_{1i} \frac{\partial \dot{\mathbf{q}}}{\partial \dot{q}_j} \right) \quad (4.50)$$

Donde la matriz \mathbf{N}_{1i} es de 6×6 :

$$\mathbf{N}_{1i} = m_{1i} \mathbf{M}_{1i}^T \mathbf{M}_{1i} + \mathbf{M}_{2i}^T \mathbf{J}_{G1i} \mathbf{M}_{2i} \quad (4.51)$$

Desarrollando $\frac{\partial L_{2i}}{\partial \dot{q}_j}$

Se tiene:

$$\frac{\partial L_{2i}}{\partial \dot{q}_j} = \frac{\partial}{\partial \dot{q}_j} \left(\frac{1}{2} \left(m_{2i} (\mathbf{v}_{G2i}^{6i})^T \mathbf{v}_{G2i}^{6i} + (\boldsymbol{\omega}_{O2i}^{6i})^T \mathbf{J}_{G2i} \boldsymbol{\omega}_{O2i}^{6i} \right) + m_{2i} \mathbf{g}^T \mathbf{r}_{G2i}^{6i} \right) \quad (4.52)$$

Sustituyendo las ecs. (4.15), (4.21) en ec. (4.52) y agrupando:

$$\begin{aligned} \frac{\partial L_{2i}}{\partial \dot{q}_j} &= \frac{1}{2} \frac{\partial}{\partial \dot{q}_j} \left(m_{2i} (\mathbf{M}_{3i} \dot{\mathbf{q}})^T \mathbf{M}_{3i} \dot{\mathbf{q}} + (\mathbf{M}_{5i} \dot{\mathbf{q}})^T \mathbf{J}_{G2i} \mathbf{M}_{5i} \dot{\mathbf{q}} \right) \\ &= \frac{1}{2} \frac{\partial}{\partial \dot{q}_j} \left(m_{2i} \dot{\mathbf{q}}^T (\mathbf{M}_{3i}^T \mathbf{M}_{3i}) \dot{\mathbf{q}} + \dot{\mathbf{q}}^T (\mathbf{M}_{5i}^T \mathbf{J}_{G2i} \mathbf{M}_{5i}) \dot{\mathbf{q}} \right) \\ &= \frac{1}{2} \frac{\partial}{\partial \dot{q}_j} \left(\dot{\mathbf{q}}^T (m_{2i} \mathbf{M}_{3i}^T \mathbf{M}_{3i} + \mathbf{M}_{5i}^T \mathbf{J}_{G2i} \mathbf{M}_{5i}) \dot{\mathbf{q}} \right) \\ \frac{\partial L_{2i}}{\partial \dot{q}_j} &= \frac{1}{2} \frac{\partial}{\partial \dot{q}_j} \left(\dot{\mathbf{q}}^T \mathbf{N}_{2i} \dot{\mathbf{q}} \right) \end{aligned}$$

Efectuando la derivada:

$$\frac{\partial L_{2i}}{\partial \dot{q}_j} = \frac{1}{2} \left(\frac{\partial \dot{\mathbf{q}}^T}{\partial \dot{q}_j} \mathbf{N}_{2i} \dot{\mathbf{q}} + \dot{\mathbf{q}}^T \mathbf{N}_{2i} \frac{\partial \dot{\mathbf{q}}}{\partial \dot{q}_j} \right) \quad (4.53)$$

Donde la matriz \mathbf{N}_{2i} es de 6×6 :

$$\mathbf{N}_{2i} = m_{2i} \mathbf{M}_{3i}^T \mathbf{M}_{3i} + \mathbf{M}_{5i}^T \mathbf{J}_{G_{2i}} \mathbf{M}_{5i} \quad (4.54)$$

Desarrollando $\frac{\partial L_{3i}}{\partial \dot{q}_j}$

Se tiene:

$$\frac{\partial L_{3i}}{\partial \dot{q}_j} = \frac{\partial}{\partial \dot{q}_j} \left(\frac{1}{2} \left(m_{3i} (\mathbf{v}_{G_{3i}}^{9i})^T \mathbf{v}_{G_{3i}}^{9i} + (\boldsymbol{\omega}_{O_{3i}}^{9i})^T \mathbf{J}_{G_{3i}} \boldsymbol{\omega}_{O_{3i}}^{9i} \right) + m_{3i} \mathbf{g}^T \mathbf{r}_{G_{3i}}^{9i} \right) \quad (4.55)$$

Sustituyendo las ecs. (4.27), (4.31) en ec. (4.55) y agrupando:

$$\begin{aligned} \frac{\partial L_{3i}}{\partial \dot{q}_j} &= \frac{1}{2} \frac{\partial}{\partial \dot{q}_j} \left(m_{3i} (\mathbf{M}_{6i} \dot{\mathbf{q}})^T \mathbf{M}_{6i} \dot{\mathbf{q}} + (\mathbf{M}_{8i} \dot{\mathbf{q}})^T \mathbf{J}_{G_{3i}} \mathbf{M}_{8i} \dot{\mathbf{q}} \right) \\ &= \frac{1}{2} \frac{\partial}{\partial \dot{q}_j} \left(m_{3i} \dot{\mathbf{q}}^T (\mathbf{M}_{6i}^T \mathbf{M}_{6i}) \dot{\mathbf{q}} + \dot{\mathbf{q}}^T (\mathbf{M}_{8i}^T \mathbf{J}_{G_{3i}} \mathbf{M}_{8i}) \dot{\mathbf{q}} \right) \\ &= \frac{1}{2} \frac{\partial}{\partial \dot{q}_j} \left(\dot{\mathbf{q}}^T (m_{3i} \mathbf{M}_{6i}^T \mathbf{M}_{6i} + \mathbf{M}_{8i}^T \mathbf{J}_{G_{3i}} \mathbf{M}_{8i}) \dot{\mathbf{q}} \right) \\ \frac{\partial L_{3i}}{\partial \dot{q}_j} &= \frac{1}{2} \frac{\partial}{\partial \dot{q}_j} (\dot{\mathbf{q}}^T \mathbf{N}_{3i} \dot{\mathbf{q}}) \end{aligned}$$

Efectuando la derivada:

$$\frac{\partial L_{3i}}{\partial \dot{q}_j} = \frac{1}{2} \left(\frac{\partial \dot{\mathbf{q}}^T}{\partial \dot{q}_j} \mathbf{N}_{3i} \dot{\mathbf{q}} + \dot{\mathbf{q}}^T \mathbf{N}_{3i} \frac{\partial \dot{\mathbf{q}}}{\partial \dot{q}_j} \right) \quad (4.56)$$

Donde la matriz \mathbf{N}_{3i} es de 6×6 :

$$\mathbf{N}_{3i} = m_{3i} \mathbf{M}_{6i}^T \mathbf{M}_{6i} + \mathbf{M}_{8i}^T \mathbf{J}_{G_{3i}} \mathbf{M}_{8i} \quad (4.57)$$

Desarrollando $\frac{\partial L_p}{\partial \dot{q}_j}$

Se tiene:

$$\frac{\partial L_p}{\partial \dot{q}_j} = \frac{\partial}{\partial \dot{q}_j} \left(\frac{1}{2} \left(m_p (\mathbf{v}_{G_p}^p)^T \mathbf{v}_{G_p}^p + (\boldsymbol{\omega}_{O_p}^p)^T \mathbf{J}_{G_p} \boldsymbol{\omega}_{O_p}^p \right) + m_p \mathbf{g}^T \mathbf{r}_{G_p}^p \right) \quad (4.58)$$

Sustituyendo las ecs. (4.35), (4.39) en ec. (4.58) y agrupando:

$$\begin{aligned} \frac{\partial L_p}{\partial \dot{q}_j} &= \frac{1}{2} \frac{\partial}{\partial \dot{q}_j} \left(m_p (\mathbf{M}_9 \dot{\mathbf{q}})^T \mathbf{M}_9 \dot{\mathbf{q}} + (\mathbf{M}_{10} \dot{\mathbf{q}})^T \mathbf{J}_{G_p} \mathbf{M}_{10} \dot{\mathbf{q}} \right) \\ &= \frac{1}{2} \frac{\partial}{\partial \dot{q}_j} \left(m_p \dot{\mathbf{q}}^T (\mathbf{M}_9^T \mathbf{M}_9) \dot{\mathbf{q}} + \dot{\mathbf{q}}^T (\mathbf{M}_{10}^T \mathbf{J}_{G_p} \mathbf{M}_{10}) \dot{\mathbf{q}} \right) \end{aligned}$$

$$= \frac{1}{2} \frac{\partial}{\partial \dot{q}_j} \left(\dot{q}^T (m_p \mathbf{M}_9^T \mathbf{M}_9 + \mathbf{M}_{10}^T \mathbf{J}_{G_p} \mathbf{M}_{10}) \dot{q} \right)$$

$$\frac{\partial L_p}{\partial \dot{q}_j} = \frac{1}{2} \frac{\partial}{\partial \dot{q}_j} (\dot{q}^T \mathbf{N}_4 \dot{q})$$

Efectuando la derivada:

$$\frac{\partial L_p}{\partial \dot{q}_j} = \frac{1}{2} \left(\frac{\partial \dot{q}^T}{\partial \dot{q}_j} \mathbf{N}_4 \dot{q} + \dot{q}^T \mathbf{N}_4 \frac{\partial \dot{q}}{\partial \dot{q}_j} \right) \quad (4.59)$$

Donde la matriz \mathbf{N}_4 es de 6×6 :

$$\mathbf{N}_4 = m_p \mathbf{M}_9^T \mathbf{M}_9 + \mathbf{M}_{10}^T \mathbf{J}_{G_p} \mathbf{M}_{10} \quad (4.60)$$

Desarrollando $\frac{\partial L_c}{\partial \dot{q}_j}$

Se tiene:

$$\frac{\partial L_c}{\partial \dot{q}_j} = \frac{\partial}{\partial \dot{q}_j} \left(\frac{1}{2} \left(m_c (\mathbf{v}_{G_c}^p)^T \mathbf{v}_{G_c}^p + (\boldsymbol{\omega}_{O_c}^p)^T \mathbf{J}_{G_c} \boldsymbol{\omega}_{O_c}^p \right) + m_c \mathbf{g}^T \mathbf{r}_{G_c}^p \right) \quad (4.61)$$

Sustituyendo las ecs. (4.43), (4.45) en ec. (4.61) y agrupando:

$$\begin{aligned} \frac{\partial L_c}{\partial \dot{q}_j} &= \frac{1}{2} \frac{\partial}{\partial \dot{q}_j} \left(m_p (\mathbf{M}_{11} \dot{q})^T \mathbf{M}_{11} \dot{q} + (\mathbf{M}_{10} \dot{q})^T \mathbf{J}_{G_p} \mathbf{M}_{10} \dot{q} \right) \\ &= \frac{1}{2} \frac{\partial}{\partial \dot{q}_j} \left(m_c \dot{q}^T (\mathbf{M}_{11}^T \mathbf{M}_{11}) \dot{q} + \dot{q}^T (\mathbf{M}_{10}^T \mathbf{J}_{G_c} \mathbf{M}_{10}) \dot{q} \right) \\ &= \frac{1}{2} \frac{\partial}{\partial \dot{q}_j} \left(\dot{q}^T (m_c \mathbf{M}_{11}^T \mathbf{M}_{11} + \mathbf{M}_{10}^T \mathbf{J}_{G_c} \mathbf{M}_{10}) \dot{q} \right) \\ \frac{\partial L_c}{\partial \dot{q}_j} &= \frac{1}{2} \frac{\partial}{\partial \dot{q}_j} (\dot{q}^T \mathbf{N}_5 \dot{q}) \end{aligned}$$

Efectuando la derivada:

$$\frac{\partial L_c}{\partial \dot{q}_j} = \frac{1}{2} \left(\frac{\partial \dot{q}^T}{\partial \dot{q}_j} \mathbf{N}_5 \dot{q} + \dot{q}^T \mathbf{N}_5 \frac{\partial \dot{q}}{\partial \dot{q}_j} \right) \quad (4.62)$$

Donde la matriz \mathbf{N}_5 es de 6×6 :

$$\mathbf{N}_5 = m_c \mathbf{M}_{11}^T \mathbf{M}_{11} + \mathbf{M}_{10}^T \mathbf{J}_{G_c} \mathbf{M}_{10} \quad (4.63)$$

Al evaluar el término $\frac{\partial \dot{q}^T}{\partial \dot{q}_j}$, dependerá que valor tome j , de tal manera que se tienen los siguientes resultados para diferente valor del iterador j . De esta forma, para:

$$j=1$$

$$\frac{\partial \dot{\mathbf{q}}^T}{\partial \dot{q}_1} = \frac{\partial}{\partial \dot{q}_1} [\dot{x}_p, \dot{y}_p, \dot{z}_p, \dot{\psi}, \dot{\theta}, \dot{\phi}] = \frac{\partial}{\partial \dot{x}_p} [\dot{x}_p, \dot{y}_p, \dot{z}_p, \dot{\psi}, \dot{\theta}, \dot{\phi}]$$

$$\frac{\partial \dot{\mathbf{q}}^T}{\partial \dot{q}_1} = [1, 0, 0, 0, 0, 0]$$

$$j=2$$

$$\frac{\partial \dot{\mathbf{q}}^T}{\partial \dot{q}_2} = \frac{\partial}{\partial \dot{q}_2} [\dot{x}_p, \dot{y}_p, \dot{z}_p, \dot{\psi}, \dot{\theta}, \dot{\phi}] = \frac{\partial}{\partial \dot{y}_p} [\dot{x}_p, \dot{y}_p, \dot{z}_p, \dot{\psi}, \dot{\theta}, \dot{\phi}]$$

$$\frac{\partial \dot{\mathbf{q}}^T}{\partial \dot{q}_2} = [0, 1, 0, 0, 0, 0]$$

$$j=3$$

$$\frac{\partial \dot{\mathbf{q}}^T}{\partial \dot{q}_3} = \frac{\partial}{\partial \dot{q}_3} [\dot{x}_p, \dot{y}_p, \dot{z}_p, \dot{\psi}, \dot{\theta}, \dot{\phi}] = \frac{\partial}{\partial \dot{z}_p} [\dot{x}_p, \dot{y}_p, \dot{z}_p, \dot{\psi}, \dot{\theta}, \dot{\phi}]$$

$$\frac{\partial \dot{\mathbf{q}}^T}{\partial \dot{q}_3} = [0, 0, 1, 0, 0, 0]$$

$$j=4$$

$$\frac{\partial \dot{\mathbf{q}}^T}{\partial \dot{q}_4} = \frac{\partial}{\partial \dot{q}_4} [\dot{x}_p, \dot{y}_p, \dot{z}_p, \dot{\psi}, \dot{\theta}, \dot{\phi}] = \frac{\partial}{\partial \dot{\psi}} [\dot{x}_p, \dot{y}_p, \dot{z}_p, \dot{\psi}, \dot{\theta}, \dot{\phi}]$$

$$\frac{\partial \dot{\mathbf{q}}^T}{\partial \dot{q}_4} = [0, 0, 0, 1, 0, 0]$$

$$j=5$$

$$\frac{\partial \dot{\mathbf{q}}^T}{\partial \dot{q}_5} = \frac{\partial}{\partial \dot{q}_5} [\dot{x}_p, \dot{y}_p, \dot{z}_p, \dot{\psi}, \dot{\theta}, \dot{\phi}] = \frac{\partial}{\partial \dot{\theta}} [\dot{x}_p, \dot{y}_p, \dot{z}_p, \dot{\psi}, \dot{\theta}, \dot{\phi}]$$

$$\frac{\partial \dot{\mathbf{q}}^T}{\partial \dot{q}_5} = [0, 0, 0, 0, 1, 0]$$

$$j=6$$

$$\frac{\partial \dot{\mathbf{q}}^T}{\partial \dot{q}_6} = \frac{\partial}{\partial \dot{q}_6} [\dot{x}_p, \dot{y}_p, \dot{z}_p, \dot{\psi}, \dot{\theta}, \dot{\phi}] = \frac{\partial}{\partial \dot{\phi}} [\dot{x}_p, \dot{y}_p, \dot{z}_p, \dot{\psi}, \dot{\theta}, \dot{\phi}]$$

$$\frac{\partial \dot{\mathbf{q}}^T}{\partial \dot{q}_6} = [0, 0, 0, 0, 0, 1]$$

Por lo tanto, se hace notar que al derivar el término $\frac{\partial \dot{\mathbf{q}}}{\partial \dot{q}_j}$ respecto al tiempo se tiene:

$$\frac{d}{dt} \left(\frac{\partial \dot{\mathbf{q}}}{\partial \dot{q}_j} \right) = \mathbf{0}$$

Ahora, tomando la ecuación (4.48) y derivando respecto al tiempo se tiene:

$$\frac{d}{dt} \left(\frac{\partial L}{\partial \dot{q}_j} \right) = \frac{d}{dt} \left(\sum_{i=1}^6 \left(\frac{\partial L_{1i}}{\partial \dot{q}_j} + \frac{\partial L_{2i}}{\partial \dot{q}_j} + \frac{\partial L_{3i}}{\partial \dot{q}_j} \right) + \frac{\partial L_p}{\partial \dot{q}_j} + \frac{\partial L_c}{\partial \dot{q}_j} \right) \quad (4.64)$$

El desarrollo de la derivada con respecto al tiempo de cada elemento se muestra a continuación:

Desarrollando $\frac{d}{dt} \left(\frac{\partial L_{1i}}{\partial \dot{q}_j} \right)$

Derivando la ec. (4.50) y agrupando se tiene:

$$\begin{aligned} \frac{d}{dt} \left(\frac{\partial L_{1i}}{\partial \dot{q}_j} \right) &= \frac{d}{dt} \left(\frac{1}{2} \left(\frac{\partial \dot{\mathbf{q}}^T}{\partial \dot{q}_j} \mathbf{N}_{1i} \dot{\mathbf{q}} + \dot{\mathbf{q}}^T \mathbf{N}_{1i} \frac{\partial \dot{\mathbf{q}}}{\partial \dot{q}_j} \right) \right) \\ &= \frac{1}{2} \left(\frac{\partial \dot{\mathbf{q}}^T}{\partial \dot{q}_j} \frac{d\mathbf{N}_{1i}}{dt} \dot{\mathbf{q}} + \frac{\partial \dot{\mathbf{q}}^T}{\partial \dot{q}_j} \mathbf{N}_{1i} \frac{d\dot{\mathbf{q}}}{dt} + \frac{d\dot{\mathbf{q}}^T}{dt} \mathbf{N}_{1i} \frac{\partial \dot{\mathbf{q}}}{\partial \dot{q}_j} + \dot{\mathbf{q}}^T \frac{d\mathbf{N}_{1i}}{dt} \frac{\partial \dot{\mathbf{q}}}{\partial \dot{q}_j} \right) \\ &= \frac{1}{2} \left(\frac{\partial \dot{\mathbf{q}}^T}{\partial \dot{q}_j} \dot{\mathbf{N}}_{1i} \dot{\mathbf{q}} + \frac{\partial \dot{\mathbf{q}}^T}{\partial \dot{q}_j} \mathbf{N}_{1i} \ddot{\mathbf{q}} + \ddot{\mathbf{q}}^T \mathbf{N}_{1i} \frac{\partial \dot{\mathbf{q}}}{\partial \dot{q}_j} + \dot{\mathbf{q}}^T \dot{\mathbf{N}}_{1i} \frac{\partial \dot{\mathbf{q}}}{\partial \dot{q}_j} \right) \end{aligned}$$

Tenemos las siguientes identidades:

$$\dot{\mathbf{q}}^T \left(\dot{\mathbf{N}}_{1i} \frac{\partial \dot{\mathbf{q}}}{\partial \dot{q}_j} \right) = \dot{\mathbf{q}}^T \mathbf{A} = \mathbf{A}^T \dot{\mathbf{q}} = \left(\frac{\partial \dot{\mathbf{q}}^T}{\partial \dot{q}_j} \dot{\mathbf{N}}_{1i}^T \right) \dot{\mathbf{q}} \quad (4.65)$$

$$\ddot{\mathbf{q}}^T \left(\mathbf{N}_{1i} \frac{\partial \dot{\mathbf{q}}}{\partial \dot{q}_j} \right) = \ddot{\mathbf{q}}^T \mathbf{B} = \mathbf{B}^T \ddot{\mathbf{q}} = \left(\frac{\partial \dot{\mathbf{q}}^T}{\partial \dot{q}_j} \mathbf{N}_{1i}^T \right) \ddot{\mathbf{q}} \quad (4.66)$$

Sustituyendo en la ec. anterior:

$$\begin{aligned} \frac{d}{dt} \left(\frac{\partial L_{1i}}{\partial \dot{q}_j} \right) &= \frac{1}{2} \left(\frac{\partial \dot{\mathbf{q}}^T}{\partial \dot{q}_j} \dot{\mathbf{N}}_{1i} \dot{\mathbf{q}} + \frac{\partial \dot{\mathbf{q}}^T}{\partial \dot{q}_j} \mathbf{N}_{1i} \ddot{\mathbf{q}} + \frac{\partial \dot{\mathbf{q}}^T}{\partial \dot{q}_j} \mathbf{N}_{1i}^T \ddot{\mathbf{q}} + \frac{\partial \dot{\mathbf{q}}^T}{\partial \dot{q}_j} \dot{\mathbf{N}}_{1i}^T \dot{\mathbf{q}} \right) \\ &= \frac{1}{2} \frac{\partial \dot{\mathbf{q}}^T}{\partial \dot{q}_j} (\mathbf{N}_{1i} + \mathbf{N}_{1i}^T) \ddot{\mathbf{q}} + \frac{1}{2} \frac{\partial \dot{\mathbf{q}}^T}{\partial \dot{q}_j} (\dot{\mathbf{N}}_{1i} + \dot{\mathbf{N}}_{1i}^T) \dot{\mathbf{q}} \\ &= \frac{1}{2} \frac{\partial \dot{\mathbf{q}}^T}{\partial \dot{q}_j} (2\mathbf{N}_{1i}) \ddot{\mathbf{q}} + \frac{1}{2} \frac{\partial \dot{\mathbf{q}}^T}{\partial \dot{q}_j} (2\dot{\mathbf{N}}_{1i}) \dot{\mathbf{q}} \\ \frac{d}{dt} \left(\frac{\partial L_{1i}}{\partial \dot{q}_j} \right) &= \frac{\partial \dot{\mathbf{q}}^T}{\partial \dot{q}_j} \mathbf{N}_{1i} \ddot{\mathbf{q}} + \frac{\partial \dot{\mathbf{q}}^T}{\partial \dot{q}_j} \dot{\mathbf{N}}_{1i} \dot{\mathbf{q}} \end{aligned}$$

Donde \mathbf{N}_{1i} es simétrica, es decir $\mathbf{N}_{1i} = \mathbf{N}_{1i}^T$, comprobando lo anterior:

$$\mathbf{N}_{1i} = m_{1i} \mathbf{M}_{1i}^T \mathbf{M}_{1i} + \mathbf{M}_{2i}^T \mathbf{J}_{G1i} \mathbf{M}_{2i}$$

$$\mathbf{N}_{1i}^T = (m_{1i} \mathbf{M}_{1i}^T \mathbf{M}_{1i})^T + (\mathbf{M}_{2i}^T \mathbf{J}_{G1i} \mathbf{M}_{2i})^T$$

$$= m_{1i} \mathbf{M}_{1i}^T \mathbf{M}_{1i} + \mathbf{M}_{2i}^T \mathbf{J}_{G1i}^T \mathbf{M}_{2i}$$

$$\mathbf{N}_{1i}^T = m_{1i} \mathbf{M}_{1i}^T \mathbf{M}_{1i} + \mathbf{M}_{2i}^T \mathbf{J}_{G1i} \mathbf{M}_{2i} = \mathbf{N}_{1i}$$

Al cumplirse que $\mathbf{J}_{G1i} = \mathbf{J}_{G1i}^T$, se comprueba que la matriz \mathbf{N}_{1i} es simétrica. Finalmente:

$$\frac{d}{dt} \left(\frac{\partial L_{1i}}{\partial \dot{q}_j} \right) = \mathbf{D}_{1ij} \ddot{\mathbf{q}} + \mathbf{V}_{1ij} \dot{\mathbf{q}} \quad (4.67)$$

Donde:

$$\begin{aligned} \mathbf{D}_{1ij} &= \frac{\partial \dot{\mathbf{q}}^T}{\partial \dot{q}_j} \mathbf{N}_{1i} \\ \mathbf{V}_{1ij} &= \frac{\partial \dot{\mathbf{q}}^T}{\partial \dot{q}_j} \dot{\mathbf{N}}_{1i} \end{aligned} \quad (4.68)$$

Además:

$$\dot{\mathbf{N}}_{1i} = m_{1i} \left(\dot{\mathbf{M}}_{1i}^T \mathbf{M}_{1i} + \mathbf{M}_{1i}^T \dot{\mathbf{M}}_{1i} \right) + \left(\dot{\mathbf{M}}_{2i}^T \mathbf{J}_{G1i} \mathbf{M}_{2i} + \mathbf{M}_{2i}^T \mathbf{J}_{G1i} \dot{\mathbf{M}}_{2i} \right)$$

$$\dot{\mathbf{M}}_{1i} = \dot{\mathbf{k}}_{1i} \mathbf{k}_{2i}^T + \mathbf{k}_{1i} \dot{\mathbf{k}}_{2i}^T$$

$$\begin{aligned} \dot{\mathbf{M}}_{2i} &= \dot{\mathbf{j}}_{4i}^{4i} \mathbf{k}_{2i}^T + \mathbf{j}_{4i}^{4i} \dot{\mathbf{k}}_{2i}^T \\ &= \mathbf{j}_{4i}^{4i} \dot{\mathbf{k}}_{2i}^T \end{aligned}$$

$$\mathbf{k}_{1i} = \mathbf{j}_{4i}^{4i} \times \mathbf{r}_{G1i'}^{4i}$$

$$\mathbf{k}_{2i}^T = \frac{1}{V_{1i}} [V_{2i}, V_{3i}, V_{4i}, V_{5i}, V_{6i}, V_{7i}]$$

$$\begin{aligned} \dot{\mathbf{k}}_{1i} &= \dot{\mathbf{j}}_{4i}^{4i} \times \mathbf{r}_{G1i'}^{4i} + \mathbf{j}_{4i}^{4i} \times \dot{\mathbf{r}}_{G1i'}^{4i} \\ &= \mathbf{j}_{4i}^{4i} \times (\boldsymbol{\omega}_{O1i}^{4i} \times \mathbf{r}_{G1i'}^{4i}) \\ &= \mathbf{j}_{4i}^{4i} \times (\dot{\theta}_{4i} \mathbf{j}_{4i}^{4i} \times \mathbf{r}_{G1i'}^{4i}) \end{aligned}$$

$$\dot{\mathbf{k}}_{2i}^T = \frac{d}{dt} \mathbf{k}_{2i}^T$$

Donde $\dot{\mathbf{j}}_{4i}^{4i} = \mathbf{0}$, ya que no cambia magnitud ni orientación.

Desarrollando $\frac{d}{dt} \left(\frac{\partial L_{2i}}{\partial \dot{q}_j} \right)$

Derivando la ec. (4.53) y agrupando se tiene:

$$\begin{aligned} \frac{d}{dt} \left(\frac{\partial L_{2i}}{\partial \dot{q}_j} \right) &= \frac{d}{dt} \left(\frac{1}{2} \left(\frac{\partial \dot{\mathbf{q}}^T}{\partial \dot{q}_j} \mathbf{N}_{2i} \dot{\mathbf{q}} + \dot{\mathbf{q}}^T \mathbf{N}_{2i} \frac{\partial \dot{\mathbf{q}}}{\partial \dot{q}_j} \right) \right) \\ &= \frac{1}{2} \frac{\partial \dot{\mathbf{q}}^T}{\partial \dot{q}_j} (\mathbf{N}_{2i} + \mathbf{N}_{2i}^T) \ddot{\mathbf{q}} + \frac{1}{2} \frac{\partial \dot{\mathbf{q}}^T}{\partial \dot{q}_j} (\dot{\mathbf{N}}_{2i} + \dot{\mathbf{N}}_{2i}^T) \dot{\mathbf{q}} \\ &= \frac{\partial \dot{\mathbf{q}}^T}{\partial \dot{q}_j} \mathbf{N}_{2i} \ddot{\mathbf{q}} + \frac{\partial \dot{\mathbf{q}}^T}{\partial \dot{q}_j} \dot{\mathbf{N}}_{2i} \dot{\mathbf{q}} \end{aligned}$$

Finalmente:

$$\frac{d}{dt} \left(\frac{\partial L_{2i}}{\partial \dot{q}_j} \right) = D_{2ij} \ddot{\mathbf{q}} + V_{2ij} \dot{\mathbf{q}} \quad (4.69)$$

Donde:

$$\begin{aligned} D_{2ij} &= \frac{\partial \dot{\mathbf{q}}^T}{\partial \dot{q}_j} \mathbf{N}_{2i} \\ V_{2ij} &= \frac{\partial \dot{\mathbf{q}}^T}{\partial \dot{q}_j} \dot{\mathbf{N}}_{2i} \end{aligned} \quad (4.70)$$

Además:

$$\mathbf{M}_{3i} = \mathbf{k}_{3i} \mathbf{k}_{2i}^T$$

$$\mathbf{M}_{4i} = \mathbf{i}_{6i}^{6i} \mathbf{k}_{4i}^T$$

$$\mathbf{M}_{5i} = \mathbf{R}_{4i}^{6i} \mathbf{M}_{2i} + \mathbf{M}_{4i}$$

$$\mathbf{k}_{3i} = \mathbf{R}_{4i}^{6i} \left(\mathbf{j}_{4i}^{4i} \times \mathbf{r}_{4i}^{4i} \right)$$

$$\mathbf{k}_{4i}^T = \frac{1}{V_{8i}} [E_{1i}, E_{2i}, E_{3i}, E_{4i}, E_{5i}, E_{6i}]$$

$$\dot{\mathbf{N}}_{2i} = m_{2i} \left(\dot{\mathbf{M}}_{3i}^T \mathbf{M}_{3i} + \mathbf{M}_{3i}^T \dot{\mathbf{M}}_{3i} \right) + \left(\dot{\mathbf{M}}_{5i}^T \mathbf{J}_{G2i} \mathbf{M}_{5i} + \mathbf{M}_{5i}^T \mathbf{J}_{G2i} \dot{\mathbf{M}}_{5i} \right)$$

$$\dot{\mathbf{M}}_{3i} = \dot{\mathbf{k}}_{3i} \mathbf{k}_{2i}^T + \mathbf{k}_{3i} \dot{\mathbf{k}}_{2i}^T$$

$$\dot{\mathbf{M}}_{5i} = \mathbf{R}_{4i}^{6i} \dot{\mathbf{M}}_{2i} + \dot{\mathbf{M}}_{4i}$$

$$\dot{\mathbf{M}}_{4i} = \mathbf{i}_{6i}^{6i} \dot{\mathbf{k}}_{4i}^T$$

$$\mathbf{k}_{3i} = \mathbf{R}_{4i}^{6i} \left(\mathbf{j}_{4i}^{4i} \times \mathbf{r}_{4i}^{4i} \right)$$

$$\mathbf{k}_{4i}^T = \frac{1}{V_{8i}} [E_{1i}, E_{2i}, E_{3i}, E_{4i}, E_{5i}, E_{6i}]$$

$$\mathbf{R}_{4i}^{6i} = \mathbf{R}_{z6} (-\delta_{6i})$$

$$\begin{aligned} \dot{\mathbf{k}}_{3i} &= \dot{\mathbf{R}}_{4i}^{6i} \left(\mathbf{j}_{4i}^{4i} \times \mathbf{r}_{4i}^{4i} \right) + \mathbf{R}_{4i}^{6i} \left(\dot{\mathbf{j}}_{4i}^{4i} \times \left(\mathbf{r}_{4i}^{4i} \right) \right) \\ &= \mathbf{R}_{4i}^{6i} \left(\dot{\mathbf{j}}_{4i}^{4i} \times \mathbf{r}_{4i}^{4i} \right) \\ &= \mathbf{R}_{4i}^{6i} \left(\dot{\mathbf{j}}_{4i}^{4i} \times \left(\boldsymbol{\omega}_{01i}^{4i} \times \mathbf{r}_{4i}^{4i} \right) \right) \\ &= \mathbf{R}_{4i}^{6i} \left(\dot{\mathbf{j}}_{4i}^{4i} \times \left(\dot{\theta}_{4i} \mathbf{j}_{4i}^{4i} \times \mathbf{r}_{4i}^{4i} \right) \right) \end{aligned}$$

$$\dot{\mathbf{k}}_{4i}^T = \frac{d}{dt} \mathbf{k}_{4i}^T$$

Donde $\dot{\mathbf{R}}_{4i}^{6i} = 0$, ya que el ángulo δ_{6i} es constante.

Desarrollando $\frac{d}{dt} \left(\frac{\partial L_{3i}}{\partial \dot{q}_j} \right)$

Derivando la ec. (4.56) y agrupando se tiene:

$$\begin{aligned} \frac{d}{dt} \left(\frac{\partial L_{3i}}{\partial \dot{q}_j} \right) &= \frac{d}{dt} \left(\frac{1}{2} \left(\frac{\partial \dot{\mathbf{q}}^T}{\partial \dot{q}_j} \mathbf{N}_{3i} \dot{\mathbf{q}} + \dot{\mathbf{q}}^T \mathbf{N}_{3i} \frac{\partial \dot{\mathbf{q}}}{\partial \dot{q}_j} \right) \right) \\ &= \frac{1}{2} \frac{\partial \dot{\mathbf{q}}^T}{\partial \dot{q}_j} (\mathbf{N}_{3i} + \mathbf{N}_{3i}^T) \ddot{\mathbf{q}} + \frac{1}{2} \frac{\partial \dot{\mathbf{q}}^T}{\partial \dot{q}_j} (\dot{\mathbf{N}}_{3i} + \dot{\mathbf{N}}_{3i}^T) \dot{\mathbf{q}} \\ &= \frac{\partial \dot{\mathbf{q}}^T}{\partial \dot{q}_j} \mathbf{N}_{3i} \ddot{\mathbf{q}} + \frac{\partial \dot{\mathbf{q}}^T}{\partial \dot{q}_j} \dot{\mathbf{N}}_{3i} \dot{\mathbf{q}} \end{aligned}$$

Finalmente:

$$\frac{d}{dt} \left(\frac{\partial L_{3i}}{\partial \dot{q}_j} \right) = \mathbf{D}_{3ij} \ddot{\mathbf{q}} + \mathbf{V}_{3ij} \dot{\mathbf{q}} \quad (4.71)$$

Donde:

$$\begin{aligned} \mathbf{D}_{3ij} &= \frac{\partial \dot{\mathbf{q}}^T}{\partial \dot{q}_j} \mathbf{N}_{3i} \\ \mathbf{V}_{3ij} &= \frac{\partial \dot{\mathbf{q}}^T}{\partial \dot{q}_j} \dot{\mathbf{N}}_{3i} \end{aligned} \quad (4.72)$$

Además:

$$\dot{\mathbf{N}}_{3i} = m_{3i} (\dot{\mathbf{M}}_{6i}^T \mathbf{M}_{6i} + \mathbf{M}_{6i}^T \dot{\mathbf{M}}_{6i}) + (\dot{\mathbf{M}}_{8i}^T \mathbf{J}_{G3i} \mathbf{M}_{8i} + \mathbf{M}_{8i}^T \mathbf{J}_{G3i} \dot{\mathbf{M}}_{8i})$$

$$\begin{aligned} \mathbf{M}_{6i} &= \mathbf{k}_{5i} \mathbf{k}_{2i}^T + \mathbf{k}_{6i} \mathbf{k}_{4i}^T + \mathbf{k}_{7i} \mathbf{k}_{8i}^T \\ \mathbf{M}_{8i} &= \mathbf{R}_{4i}^{9i} \mathbf{M}_{2i} + \mathbf{R}_{8i}^{9i} \mathbf{M}_{4i} + \mathbf{M}_{7i} \\ \mathbf{M}_{7i} &= \mathbf{j}_{9i}^{9i} \mathbf{k}_{8i}^T \end{aligned}$$

Desarrollando las derivadas de las matrices \mathbf{M}_{ni} :

$$\begin{aligned} \dot{\mathbf{M}}_{6i} &= \dot{\mathbf{k}}_{5i} \mathbf{k}_{2i}^T + \mathbf{k}_{5i} \dot{\mathbf{k}}_{2i}^T + \dot{\mathbf{k}}_{6i} \mathbf{k}_{4i}^T + \mathbf{k}_{6i} \dot{\mathbf{k}}_{4i}^T + \dot{\mathbf{k}}_{7i} \mathbf{k}_{8i}^T + \mathbf{k}_{7i} \dot{\mathbf{k}}_{8i}^T \\ \dot{\mathbf{M}}_{8i} &= \dot{\mathbf{R}}_{4i}^{9i} \mathbf{M}_{2i} + \mathbf{R}_{4i}^{9i} \dot{\mathbf{M}}_{2i} + \dot{\mathbf{R}}_{8i}^{9i} \mathbf{M}_{4i} + \mathbf{R}_{8i}^{9i} \dot{\mathbf{M}}_{4i} + \dot{\mathbf{M}}_{7i} \\ &= \dot{\mathbf{R}}_{4i}^{9i} (\mathbf{j}_{4i}^{4i} \mathbf{k}_{2i}^T) + \mathbf{R}_{4i}^{9i} \dot{\mathbf{M}}_{2i} + \dot{\mathbf{R}}_{8i}^{9i} (\mathbf{i}_{6i}^{6i} \mathbf{k}_{4i}^T) + \mathbf{R}_{8i}^{9i} \dot{\mathbf{M}}_{4i} + \dot{\mathbf{M}}_{7i} \\ &= (\dot{\mathbf{R}}_{4i}^{9i} \mathbf{j}_{4i}^{4i}) \mathbf{k}_{2i}^T + \mathbf{R}_{4i}^{9i} \dot{\mathbf{M}}_{2i} + (\dot{\mathbf{R}}_{8i}^{9i} \mathbf{i}_{8i}^{8i}) \mathbf{k}_{4i}^T + \mathbf{R}_{8i}^{9i} \dot{\mathbf{M}}_{4i} + \dot{\mathbf{M}}_{7i} \\ \dot{\mathbf{M}}_{6i} &= \dot{\mathbf{k}}_{5i} \mathbf{k}_{2i}^T + \mathbf{k}_{5i} \dot{\mathbf{k}}_{2i}^T + \dot{\mathbf{k}}_{6i} \mathbf{k}_{4i}^T + \mathbf{k}_{6i} \dot{\mathbf{k}}_{4i}^T + \dot{\mathbf{k}}_{7i} \mathbf{k}_{8i}^T + \mathbf{k}_{7i} \dot{\mathbf{k}}_{8i}^T \\ \dot{\mathbf{M}}_{7i} &= \dot{\mathbf{j}}_{9i}^{9i} \mathbf{k}_{8i}^T + \mathbf{j}_{9i}^{9i} \dot{\mathbf{k}}_{8i}^T \\ &= (\boldsymbol{\omega}_{O3i}^{9i} \times \mathbf{j}_{9i}^{9i}) \mathbf{k}_{8i}^T + \mathbf{j}_{9i}^{9i} \dot{\mathbf{k}}_{8i}^T \\ &= ((\mathbf{R}_{4i}^{9i} \boldsymbol{\omega}_{1i}^{4i} + \mathbf{R}_{8i}^{9i} \boldsymbol{\omega}_{2i}^{8i} + \boldsymbol{\omega}_{3i}^{9i}) \times \mathbf{j}_{9i}^{9i}) \mathbf{k}_{8i}^T + \mathbf{j}_{9i}^{9i} \dot{\mathbf{k}}_{8i}^T \\ &= ((\mathbf{R}_{4i}^{9i} \boldsymbol{\omega}_{1i}^{4i} + \mathbf{R}_{8i}^{9i} \boldsymbol{\omega}_{2i}^{8i}) \times \mathbf{j}_{9i}^{9i}) \mathbf{k}_{8i}^T + \mathbf{j}_{9i}^{9i} \dot{\mathbf{k}}_{8i}^T \\ &= ((\mathbf{R}_{4i}^{9i} \dot{\theta}_{4i} \mathbf{j}_{4i}^{4i} + \mathbf{R}_{8i}^{9i} \dot{\theta}_{8i} \mathbf{i}_{8i}^{8i}) \times \mathbf{j}_{9i}^{9i}) \mathbf{k}_{8i}^T + \mathbf{j}_{9i}^{9i} \dot{\mathbf{k}}_{8i}^T \end{aligned}$$

Donde:

$$\begin{aligned} \mathbf{k}_{5i} &= \mathbf{R}_{4i}^{9i} \mathbf{j}_{4i}^{4i} \times (\mathbf{r}_{4i}^{9i} + \mathbf{r}_{G3i'}^{9i}) \\ \mathbf{k}_{6i} &= \mathbf{R}_{8i}^{9i} \mathbf{i}_{8i}^{8i} \times \mathbf{r}_{G3i'}^{9i} \\ \mathbf{k}_{7i} &= \mathbf{j}_{9i}^{9i} \times \mathbf{r}_{G3i'}^{9i} \\ \mathbf{k}_{8i}^T &= \frac{1}{V_{16i}} [E_{7i}, E_{8i}, E_{9i}, E_{10i}, E_{11i}, E_{12i}] \\ \mathbf{R}_{4i}^{9i} &= \mathbf{R}_{z5}(-\theta_{9i}) \mathbf{R}_{z4}(-\theta_{8i}) \mathbf{R}_{z6}(-\delta_{6i}) \\ \mathbf{R}_{6i}^{9i} &= \mathbf{R}_{z5}(-\theta_{9i}) \mathbf{R}_{z4}(-\theta_{8i}) \\ \mathbf{R}_{8i}^{9i} &= \mathbf{R}_{z5}(-\theta_{9i}) \end{aligned}$$

Desarrollando las derivadas de los vectores \mathbf{k}_{ni} :

$$\begin{aligned} \dot{\mathbf{k}}_{5i} &= (\dot{\mathbf{R}}_{4i}^{9i} \mathbf{j}_{4i}^{4i}) \times (\mathbf{r}_{4i}^{9i} + \mathbf{r}_{G3i'}^{9i}) + \mathbf{R}_{4i}^{9i} \mathbf{j}_{4i}^{4i} \times (\dot{\mathbf{r}}_{4i}^{9i} + \dot{\mathbf{r}}_{G3i'}^{9i}) \\ &= (\dot{\mathbf{R}}_{4i}^{9i} \mathbf{j}_{4i}^{4i}) \times (\mathbf{r}_{4i}^{9i} + \mathbf{r}_{G3i'}^{9i}) + \mathbf{R}_{4i}^{9i} \mathbf{j}_{4i}^{4i} \times (\mathbf{v}_{G3i}^{9i}) \\ &= (\dot{\mathbf{R}}_{4i}^{9i} \mathbf{j}_{4i}^{4i}) \times (\mathbf{r}_{4i}^{9i} + \mathbf{r}_{G3i'}^{9i}) + \mathbf{R}_{4i}^{9i} \mathbf{j}_{4i}^{4i} \times (\mathbf{k}_{5i} \dot{\theta}_{4i} + \mathbf{k}_{6i} \dot{\theta}_{8i} + \mathbf{k}_{7i} \dot{\theta}_{9i}) \\ \dot{\mathbf{k}}_{6i} &= \dot{\mathbf{R}}_{8i}^{9i} \mathbf{i}_{8i}^{8i} \times (\mathbf{r}_{G3i'}^{9i}) + \mathbf{R}_{8i}^{9i} \mathbf{i}_{8i}^{8i} \times (\dot{\mathbf{r}}_{G3i'}^{9i}) \\ &= \dot{\mathbf{R}}_{8i}^{9i} \mathbf{i}_{8i}^{8i} \times (\mathbf{r}_{G3i'}^{9i}) + \mathbf{R}_{8i}^{9i} \mathbf{i}_{8i}^{8i} \times ((\mathbf{R}_{4i}^{9i} \boldsymbol{\omega}_{1i}^{4i} + \mathbf{R}_{8i}^{9i} \boldsymbol{\omega}_{2i}^{8i} + \boldsymbol{\omega}_{3i}^{9i}) \times \mathbf{r}_{G3i'}^{9i}) \\ \dot{\mathbf{k}}_{6i} &= \dot{\mathbf{R}}_{8i}^{9i} \mathbf{i}_{8i}^{8i} \times (\mathbf{r}_{G3i'}^{9i}) + \mathbf{R}_{8i}^{9i} \mathbf{i}_{8i}^{8i} \times ((\mathbf{R}_{4i}^{9i} (\mathbf{j}_{4i}^{4i} \dot{\theta}_{4i}) + \mathbf{R}_{8i}^{9i} (\mathbf{i}_{8i}^{8i} \dot{\theta}_{8i}) + (\mathbf{j}_{9i}^{9i} \dot{\theta}_{9i})) \times \mathbf{r}_{G3i'}^{9i}) \\ \dot{\mathbf{k}}_{7i} &= \dot{\mathbf{j}}_{9i}^{9i} \times \mathbf{r}_{G3i'}^{9i} + \mathbf{j}_{9i}^{9i} \times \dot{\mathbf{r}}_{G3i'}^{9i} \\ &= ((\mathbf{R}_{4i}^{9i} \boldsymbol{\omega}_{1i}^{4i} + \mathbf{R}_{8i}^{9i} \boldsymbol{\omega}_{2i}^{8i}) \times \mathbf{j}_{9i}^{9i}) \times \mathbf{r}_{G3i'}^{9i} + \mathbf{j}_{9i}^{9i} \times (\boldsymbol{\omega}_{O3i}^{9i} \times \mathbf{r}_{G3i'}^{9i}) \\ &= ((\mathbf{R}_{4i}^{9i} \boldsymbol{\omega}_{1i}^{4i} + \mathbf{R}_{8i}^{9i} \boldsymbol{\omega}_{2i}^{8i}) \times \mathbf{j}_{9i}^{9i}) \times \mathbf{r}_{G3i'}^{9i} + \mathbf{j}_{9i}^{9i} \times ((\mathbf{R}_{4i}^{9i} \boldsymbol{\omega}_{1i}^{4i} + \mathbf{R}_{8i}^{9i} \boldsymbol{\omega}_{2i}^{8i} + \boldsymbol{\omega}_{3i}^{9i}) \times \mathbf{r}_{G3i'}^{9i}) \\ &= ((\mathbf{R}_{4i}^{9i} \dot{\theta}_{4i} \mathbf{j}_{4i}^{4i} + \mathbf{R}_{8i}^{9i} \dot{\theta}_{8i} \mathbf{i}_{8i}^{8i}) \times \mathbf{j}_{9i}^{9i}) \times \mathbf{r}_{G3i'}^{9i} + \mathbf{j}_{9i}^{9i} \times ((\mathbf{R}_{4i}^{9i} \dot{\theta}_{4i} \mathbf{j}_{4i}^{4i} + \mathbf{R}_{8i}^{9i} \dot{\theta}_{8i} \mathbf{i}_{8i}^{8i} + \mathbf{j}_{9i}^{9i} \dot{\theta}_{9i}) \times \mathbf{r}_{G3i'}^{9i}) \\ \dot{\mathbf{k}}_{8i}^T &= \frac{d}{dt} (\mathbf{k}_{8i}^T) \end{aligned}$$

Se hace notar que \mathbf{i}_{6i}^{6i} es paralelo a \mathbf{i}_{8i}^{8i} .

Ahora, con el fin de obtener los términos del tipo $\dot{\mathbf{R}}_{\rho} \mathbf{r}$ de manera vectorial, se sabe que la velocidad de un vector que solo cambia de dirección, se escribe matricialmente de la siguiente manera:

$$\mathbf{v} = \mathbf{W} \mathbf{r}$$

Donde \mathbf{W} es la matriz de velocidad. Tal que:

$$W = \dot{R}R^T = \begin{bmatrix} 0 & -\omega_z & \omega_y \\ \omega_z & 0 & -\omega_x \\ -\omega_y & \omega_x & 0 \end{bmatrix}$$

Por lo tanto de forma general se tiene:

$$v = W r = \dot{R}R^T r = \omega \times r$$

Donde ω es el vector axial de la matriz antisimétrica W . Tomando en cuenta lo anterior, de forma particular para obtener el término $\dot{R}_{4i}^{9i} J_{4i}^{4i}$ se tiene:

$$\begin{aligned} v_{49i} &= \dot{R}_{4i}^{9i} J_{4i}^{4i} \\ &= \dot{R}_{4i}^{9i} I J_{4i}^{4i} \\ &= \dot{R}_{4i}^{9i} R_{4i}^{9iT} (R_{4i}^{9i} J_{4i}^{4i}) \\ &= W (R_{4i}^{9i} J_{4i}^{4i}) \\ v_{49i} &= \omega_{94i} \times R_{4i}^{9i} J_{4i}^{4i} \end{aligned}$$

Donde se ha utilizado la sig. nomenclatura ω_{ij}^k ; velocidad angular de la base j vista desde i y proyectada en k . De tal forma que:

$$\dot{R}_{4i}^{9i} J_{4i}^{4i} = \omega_{94i} \times R_{4i}^{9i} J_{4i}^{4i} \quad (4.73)$$

Con el fin de obtener el vector ω_{94i}^{9i} se tiene de la ec. (3.37):

$$\omega_{O3i}^{9i} = \omega_{1i}^{9i} + \omega_{2i}^{9i} + \omega_{3i}^{9i}$$

La derivada de la matriz de rotación R_{4i}^{9i} , no toma en cuenta el movimiento del cuerpo $1i$, ya que solo contiene derivadas de los ángulos δ_{6i} , θ_{8i} y θ_{9i} , por lo tanto reescribiendo la ec. anterior:

$$\omega_{49i}^{9i} = \omega_{O3i}^{9i} - \omega_{1i}^{9i} = \omega_{2i}^{9i} + \omega_{3i}^{9i}$$

En la ecuación anterior se muestra la velocidad ω_{49i}^{9i} de la base $9i$ vista desde la base $4i$ y proyectada en la base $9i$, con el fin de que esta sea vista desde la base $9i$, se aplica la propiedad de la velocidad angular (McGill, y otros, 1991), $\omega_{94i}^{9i} = -\omega_{49i}^{9i}$. Tal que:

$$\omega_{94i}^{9i} = -\omega_{2i}^{9i} - \omega_{3i}^{9i}$$

Sustituyendo cada uno de los términos de velocidad:

$$\begin{aligned} \omega_{94i}^{9i} &= -R_{8i}^{9i} \omega_{2i}^{8i} - \omega_{3i}^{9i} \\ &= -R_{8i}^{9i} \dot{\theta}_{8i} i_{8i}^{8i} - \dot{\theta}_{9i} j_{9i}^{9i} \end{aligned} \quad (4.74)$$

Ahora, para obtener el término $\dot{R}_{8i}^{9i} i_{8i}^{8i}$, procedemos de manera similar:

$$\dot{R}_{8i}^{9i} i_{8i}^{8i} = \omega_{98i}^{9i} \times R_{8i}^{9i} i_{8i}^{8i} \quad (4.75)$$

Con el fin de obtener el vector ω_{98i}^{9i} se tiene de la ec. (3.37):

$$\omega_{O3i}^{9i} = \omega_{1i}^{9i} + \omega_{2i}^{9i} + \omega_{3i}^{9i}$$

La derivada de la matriz de rotación \mathbf{R}_{8i}^{9i} , no toma en cuenta el movimiento de los cuerpos $1i$ y $2i$, ya que solo contiene derivada del ángulo θ_{9i} , por lo tanto reescribiendo la ec. anterior:

$$\boldsymbol{\omega}_{89i}^{9i} = \boldsymbol{\omega}_{O3i}^{9i} - \boldsymbol{\omega}_{1i}^{9i} - \boldsymbol{\omega}_{2i}^{9i} = \boldsymbol{\omega}_{3i}^{9i}$$

La velocidad $\boldsymbol{\omega}_{89i}^{9i}$, es la velocidad de la base $9i$ vista desde la base $8i$ y proyectada en la base $9i$, con el fin de que esta sea vista desde la base $9i$, se aplica $\boldsymbol{\omega}_{98i}^{9i} = -\boldsymbol{\omega}_{89i}^{9i}$. Tal que:

$$\boldsymbol{\omega}_{98i}^{9i} = -\boldsymbol{\omega}_{3i}^{9i}$$

Sustituyendo cada uno de los términos de velocidad:

$$\begin{aligned} \boldsymbol{\omega}_{98i}^{9i} &= -\boldsymbol{\omega}_{3i}^{9i} \\ &= -\dot{\theta}_{9i} \mathbf{J}_{9i}^{9i} \end{aligned} \quad (4.76)$$

Reescribiendo $\dot{\mathbf{k}}_{5i}$, $\dot{\mathbf{k}}_{6i}$ y $\dot{\mathbf{M}}_{8i}$ tomando en cuenta las ecs. (4.73) y (4.75):

$$\dot{\mathbf{k}}_{5i} = (\boldsymbol{\omega}_{94i}^{9i} \times \mathbf{R}_{4i}^{9i} \mathbf{J}_{4i}^{4i}) \times (\mathbf{r}_{4i}^{9i} + \mathbf{r}_{G3i'}^{9i}) + \mathbf{R}_{4i}^{9i} \mathbf{J}_{4i}^{4i} \times (\mathbf{k}_{5i} \dot{\theta}_{4i} + \mathbf{k}_{6i} \dot{\theta}_{8i} + \mathbf{k}_{7i} \dot{\theta}_{9i})$$

$$\dot{\mathbf{k}}_{6i} = (\boldsymbol{\omega}_{98i}^{9i} \times \mathbf{R}_{8i}^{9i} \mathbf{i}_{8i}^{8i}) \times \mathbf{r}_{G3i'}^{9i} + \mathbf{R}_{8i}^{9i} \mathbf{i}_{8i}^{8i} \times \left((\mathbf{R}_{4i}^{9i} (\mathbf{J}_{4i}^{4i} \dot{\theta}_{4i}) + \mathbf{R}_{8i}^{9i} (\mathbf{i}_{8i}^{8i} \dot{\theta}_{8i}) + (\mathbf{J}_{9i}^{9i} \dot{\theta}_{9i})) \times \mathbf{r}_{G3i'}^{9i} \right)$$

$$\begin{aligned} \dot{\mathbf{M}}_{8i} &= (\dot{\mathbf{R}}_{4i}^{9i} \mathbf{J}_{4i}^{4i}) \mathbf{k}_{2i}^T + \mathbf{R}_{4i}^{9i} \dot{\mathbf{M}}_{2i} + (\dot{\mathbf{R}}_{8i}^{9i} \mathbf{i}_{6i}^{6i}) \mathbf{k}_{4i}^T + \mathbf{R}_{8i}^{9i} \dot{\mathbf{M}}_{4i} + \dot{\mathbf{M}}_{7i} \\ &= (\boldsymbol{\omega}_{94i}^{9i} \times \mathbf{R}_{4i}^{9i} \mathbf{J}_{4i}^{4i}) \mathbf{k}_{2i}^T + \mathbf{R}_{4i}^{9i} \dot{\mathbf{M}}_{2i} + (\boldsymbol{\omega}_{98i}^{9i} \times \mathbf{R}_{8i}^{9i} \mathbf{i}_{6i}^{6i}) \mathbf{k}_{4i}^T + \mathbf{R}_{8i}^{9i} \dot{\mathbf{M}}_{4i} + \dot{\mathbf{M}}_{7i} \end{aligned}$$

Desarrollando $\frac{d}{dt} \left(\frac{\partial L_p}{\partial \dot{q}_j} \right)$

Derivando la ec. (4.59) y agrupando se tiene:

$$\begin{aligned} \frac{d}{dt} \left(\frac{\partial L_p}{\partial \dot{q}_j} \right) &= \frac{d}{dt} \left(\frac{1}{2} \left(\frac{\partial \dot{\mathbf{q}}^T}{\partial \dot{q}_j} \mathbf{N}_4 \dot{\mathbf{q}} + \dot{\mathbf{q}}^T \mathbf{N}_4 \frac{\partial \dot{\mathbf{q}}}{\partial \dot{q}_j} \right) \right) \\ &= \frac{1}{2} \frac{\partial \dot{\mathbf{q}}^T}{\partial \dot{q}_j} (\mathbf{N}_4 + \mathbf{N}_4^T) \ddot{\mathbf{q}} + \frac{1}{2} \frac{\partial \dot{\mathbf{q}}^T}{\partial \dot{q}_j} (\dot{\mathbf{N}}_4 + \dot{\mathbf{N}}_4^T) \dot{\mathbf{q}} \\ &= \frac{\partial \dot{\mathbf{q}}^T}{\partial \dot{q}_j} \mathbf{N}_4 \ddot{\mathbf{q}} + \frac{\partial \dot{\mathbf{q}}^T}{\partial \dot{q}_j} \dot{\mathbf{N}}_4 \dot{\mathbf{q}} \end{aligned}$$

Finalmente:

$$\frac{d}{dt} \left(\frac{\partial L_p}{\partial \dot{q}_j} \right) = \mathbf{D}_{4j} \ddot{\mathbf{q}} + \mathbf{V}_{4j} \dot{\mathbf{q}} \quad (4.77)$$

Donde:

$$\begin{aligned} \mathbf{D}_{4j} &= \frac{\partial \dot{\mathbf{q}}^T}{\partial \dot{q}_j} \mathbf{N}_4 \\ \mathbf{V}_{4j} &= \frac{\partial \dot{\mathbf{q}}^T}{\partial \dot{q}_j} \dot{\mathbf{N}}_4 \end{aligned} \quad (4.78)$$

Además:

$$\mathbf{N}_4 = m_p \mathbf{M}_9^T \mathbf{M}_9 + \mathbf{M}_{10}^T \mathbf{J}_{Gp} \mathbf{M}_{10}$$

$$\dot{\mathbf{N}}_4 = m_p \left(\dot{\mathbf{M}}_9^T \mathbf{M}_9 + \mathbf{M}_9^T \dot{\mathbf{M}}_9 \right) + \left(\dot{\mathbf{M}}_{10}^T \mathbf{J}_{Gp} \mathbf{M}_{10} + \mathbf{M}_{10}^T \mathbf{J}_{Gp} \dot{\mathbf{M}}_{10} \right)$$

$$\mathbf{M}_9 = [\mathbf{R}_0^p, \mathbf{k}_9, \mathbf{k}_{10}, \mathbf{k}_{11}]$$

$$\mathbf{M}_{10} = [\mathbf{0}, \mathbf{0}, \mathbf{0}, \mathbf{k}_{12}, \mathbf{k}_{13}, \mathbf{k}_{14}]$$

$$\dot{\mathbf{M}}_9 = [\dot{\mathbf{R}}_0^p, \dot{\mathbf{k}}_9, \dot{\mathbf{k}}_{10}, \dot{\mathbf{k}}_{11}]$$

$$\dot{\mathbf{M}}_{10} = [\mathbf{0}, \mathbf{0}, \mathbf{0}, \dot{\mathbf{k}}_{12}, \dot{\mathbf{k}}_{13}, \dot{\mathbf{k}}_{14}]$$

$$\mathbf{R}_0^p = \mathbf{R}_{z6}(-\phi) \mathbf{R}_{z4}(-\theta) \mathbf{R}_{z6}(-\psi)$$

$$\mathbf{R}_{18}^p = \mathbf{R}_{z6}(-\phi) \mathbf{R}_{z4}(-\theta)$$

$$\mathbf{R}_{19}^p = \mathbf{R}_{z6}(-\phi)$$

$$\mathbf{R}_0^{18i} = \mathbf{R}_{z6}(-\psi)$$

$$\mathbf{R}_0^{19i} = \mathbf{R}_{z4}(-\theta) \mathbf{R}_{z6}(-\psi)$$

$$\mathbf{R}_{18}^{19} = \mathbf{R}_{z6}(-\phi)$$

$$\dot{\mathbf{R}}_{18}^p = \frac{\partial \mathbf{R}_{z6}(-\phi)}{\partial \phi} \mathbf{R}_{z4}(-\theta) \dot{\phi} + \mathbf{R}_{z6}(-\phi) \frac{\partial \mathbf{R}_{z4}(-\theta)}{\partial \theta} \dot{\theta}$$

$$\dot{\mathbf{R}}_{19}^p = \frac{\partial \mathbf{R}_{z6}(-\phi)}{\partial \phi} \dot{\phi}$$

Derivando los vectores \mathbf{k}_n :

$$\dot{\mathbf{k}}_9 = \dot{\mathbf{R}}_0^p \mathbf{k}_0^0 \times \mathbf{r}_{Gp'}^p + \mathbf{R}_0^p \dot{\mathbf{k}}_0^0 \times \mathbf{r}_{Gp'}^p$$

$$= \dot{\mathbf{R}}_0^p \mathbf{k}_0^0 \times \mathbf{r}_{Gp'}^p + \mathbf{R}_0^p \dot{\mathbf{k}}_0^0 \times (\boldsymbol{\omega}_{Op}^p \times \mathbf{r}_{Gp'}^p)$$

$$= \dot{\mathbf{R}}_0^p \mathbf{k}_0^0 \times \mathbf{r}_{Gp'}^p + \mathbf{R}_0^p \dot{\mathbf{k}}_0^0 \times \left((\mathbf{k}_{12} \dot{\psi} + \mathbf{k}_{13} \dot{\theta} + \mathbf{k}_{14} \dot{\phi}) \times \mathbf{r}_{Gp'}^p \right)$$

$$\dot{\mathbf{k}}_{10} = \dot{\mathbf{R}}_{18}^p \mathbf{i}_{18}^{18} \times \mathbf{r}_{Gp'}^p + \mathbf{R}_{18}^p \dot{\mathbf{i}}_{18}^{18} \times \mathbf{r}_{Gp'}^p + \mathbf{R}_{18}^p \mathbf{i}_{18}^{18} \times \dot{\mathbf{r}}_{Gp'}^p$$

$$= \dot{\mathbf{R}}_{18}^p \mathbf{i}_{18}^{18} \times \mathbf{r}_{Gp'}^p + \mathbf{R}_{18}^p (\mathbf{R}_0^{18} \boldsymbol{\omega}_\psi^0 \times \mathbf{i}_{18}^{18}) \times \mathbf{r}_{Gp'}^p + \mathbf{R}_{18}^p \mathbf{i}_{18}^{18} \times (\boldsymbol{\omega}_{Op}^p \times \mathbf{r}_{Gp'}^p)$$

$$= \dot{\mathbf{R}}_{18}^p \mathbf{i}_{18}^{18} \times \mathbf{r}_{Gp'}^p + \mathbf{R}_{18}^p (\dot{\psi} \mathbf{k}_0^0 \times \mathbf{i}_{18}^{18}) \times \mathbf{r}_{Gp'}^p + \mathbf{R}_{18}^p \mathbf{i}_{18}^{18} \times \left((\mathbf{k}_{12} \dot{\psi} + \mathbf{k}_{13} \dot{\theta} + \mathbf{k}_{14} \dot{\phi}) \times \mathbf{r}_{Gp'}^p \right)$$

$$\dot{\mathbf{k}}_{11} = \dot{\mathbf{k}}_{19}^{19} \times \mathbf{r}_{Gp'}^p + \mathbf{k}_{19}^{19} \times \dot{\mathbf{r}}_{Gp'}^p$$

$$= \left((\mathbf{R}_0^{19} \boldsymbol{\omega}_\psi^0 + \mathbf{R}_{18}^{19} \boldsymbol{\omega}_\theta^{18}) \times \mathbf{k}_{19}^{19} \right) \times \mathbf{r}_{Gp'}^p + \mathbf{k}_{19}^{19} \times (\boldsymbol{\omega}_{Op}^p \times \mathbf{r}_{Gp'}^p)$$

$$= \left((\mathbf{R}_0^{19} \boldsymbol{\omega}_\psi^0 + \mathbf{R}_{18}^{19} \boldsymbol{\omega}_\theta^{18}) \times \mathbf{k}_{19}^{19} \right) \times \mathbf{r}_{Gp'}^p + \mathbf{k}_{19}^{19} \times \left((\mathbf{k}_{12} \dot{\psi} + \mathbf{k}_{13} \dot{\theta} + \mathbf{k}_{14} \dot{\phi}) \times \mathbf{r}_{Gp'}^p \right)$$

$$\begin{aligned}
\dot{\mathbf{k}}_{12} &= \dot{\mathbf{R}}_0^p \mathbf{k}_0^0 + \mathbf{R}_0^p \dot{\mathbf{k}}_0^0 = \dot{\mathbf{R}}_0^p \mathbf{k}_0^0 \\
\dot{\mathbf{k}}_{13} &= \dot{\mathbf{R}}_{18}^p \mathbf{i}_{18}^{18} + \mathbf{R}_{18}^p \dot{\mathbf{i}}_{18}^{18} \\
&= \dot{\mathbf{R}}_{18}^p \mathbf{i}_{18}^{18} + \mathbf{R}_{18}^p (\mathbf{R}_0^{18} \boldsymbol{\omega}_\psi^0 \times \mathbf{i}_{18}^{18}) \\
\dot{\mathbf{k}}_{14} &= \dot{\mathbf{k}}_{19}^{19} = (\mathbf{R}_0^{19} \boldsymbol{\omega}_\psi^0 + \mathbf{R}_{18}^{19} \boldsymbol{\omega}_\theta^{18}) \times \mathbf{k}_{19}^{19}
\end{aligned}$$

Para obtener el término $\dot{\mathbf{R}}_0^p \mathbf{k}_0^0$, haciendo algo similar al procedimiento para obtener el término $\dot{\mathbf{R}}_{4i}^{4i} \mathbf{j}_{4i}^{4i}$, se tiene:

$$\dot{\mathbf{R}}_0^p \mathbf{k}_0^0 = \boldsymbol{\omega}_{pO}^p \times \mathbf{R}_0^p \mathbf{k}_0^0 \quad (4.79)$$

Con el fin de obtener el vector $\boldsymbol{\omega}_{pO}^p$ se tiene de la ec. (3.60):

$$\boldsymbol{\omega}_{Op}^p = \boldsymbol{\omega}_\psi^p + \boldsymbol{\omega}_\theta^p + \boldsymbol{\omega}_\phi^p$$

La velocidad $\boldsymbol{\omega}_{Op}^p$, es la velocidad de la base p vista desde la base inercial y proyectada en la base p , con el fin de que esta sea vista desde la base p , se aplica $\boldsymbol{\omega}_{pO}^p = -\boldsymbol{\omega}_{Op}^p$. Tal que:

$$\boldsymbol{\omega}_{pO}^p = -\boldsymbol{\omega}_\psi^p - \boldsymbol{\omega}_\theta^p - \boldsymbol{\omega}_\phi^p$$

Sustituyendo cada uno de los términos de velocidad:

$$\begin{aligned}
\boldsymbol{\omega}_{pO}^p &= -\boldsymbol{\omega}_{Op}^p \\
&= -\mathbf{k}_{12} \dot{\psi} - \mathbf{k}_{13} \dot{\theta} - \mathbf{k}_{14} \dot{\phi}
\end{aligned} \quad (4.80)$$

Ahora, para obtener el término $\dot{\mathbf{R}}_{18}^p \mathbf{i}_{18}^{18}$, haciendo algo similar se tiene:

$$\dot{\mathbf{R}}_{18}^p \mathbf{i}_{18}^{18} = \boldsymbol{\omega}_{p18}^p \times \mathbf{R}_{18}^p \mathbf{i}_{18}^{18} \quad (4.81)$$

Con el fin de obtener el vector $\boldsymbol{\omega}_{p18}^p$ se tiene de la ec. (3.60):

$$\boldsymbol{\omega}_{Op}^p = \boldsymbol{\omega}_\psi^p + \boldsymbol{\omega}_\theta^p + \boldsymbol{\omega}_\phi^p$$

La derivada de la matriz \mathbf{R}_{18p}^p , no toma en cuenta el movimiento del ángulo ψ , ya que solo contiene derivadas de los ángulos θ y ϕ , por lo tanto reescribiendo la ec. anterior:

$$\begin{aligned}
\boldsymbol{\omega}_{18p}^p &= \boldsymbol{\omega}_{Op}^p - \boldsymbol{\omega}_\psi^p \\
&= \boldsymbol{\omega}_\theta^p + \boldsymbol{\omega}_\phi^p
\end{aligned}$$

La velocidad $\boldsymbol{\omega}_{18p}^p$, es la velocidad de la base p vista desde la base 18 y proyectada en la base p , con el fin de que esta sea vista desde la base p , se aplica $\boldsymbol{\omega}_{p18}^p = -\boldsymbol{\omega}_{18p}^p$. Tal que:

$$\boldsymbol{\omega}_{p18}^p = -\boldsymbol{\omega}_\theta^p - \boldsymbol{\omega}_\phi^p$$

Sustituyendo cada uno de los términos de velocidad:

$$\boldsymbol{\omega}_{p18}^p = -\mathbf{k}_{13} \dot{\theta} - \mathbf{k}_{14} \dot{\phi} \quad (4.82)$$

Reescribiendo $\dot{\mathbf{k}}_{10}$, $\dot{\mathbf{k}}_{11}$, $\dot{\mathbf{k}}_{13}$ y $\dot{\mathbf{k}}_{14}$ tomando en cuenta las ecs. (4.79) y (4.81):

$$\begin{aligned}\dot{\mathbf{k}}_9 &= (\boldsymbol{\omega}_{pO}^p \times \mathbf{R}_0^p \mathbf{k}_0^0) \times \mathbf{r}_{Gp'}^p + \mathbf{R}_0^p \mathbf{k}_0^0 \times \left((\mathbf{k}_{12} \dot{\psi} + \mathbf{k}_{13} \dot{\theta} + \mathbf{k}_{14} \dot{\phi}) \times \mathbf{r}_{Gp'}^p \right) \\ \dot{\mathbf{k}}_{10} &= (\boldsymbol{\omega}_{p18}^p \times \mathbf{R}_{18}^p \mathbf{i}_{18}^{18}) \times \mathbf{r}_{Gp'}^p + \mathbf{R}_{18}^p (\dot{\psi} \mathbf{k}_0^0 \times \mathbf{i}_{18}^{18}) \times \mathbf{r}_{Gp'}^p + \mathbf{R}_{18}^p \mathbf{i}_{18}^{18} \times \left((\mathbf{k}_{12} \dot{\psi} + \mathbf{k}_{13} \dot{\theta} + \mathbf{k}_{14} \dot{\phi}) \times \mathbf{r}_{Gp'}^p \right) \\ \dot{\mathbf{k}}_{12} &= (\boldsymbol{\omega}_{pO}^p \times \mathbf{R}_0^p \mathbf{k}_0^0) \\ \dot{\mathbf{k}}_{13} &= (\boldsymbol{\omega}_{p18}^p \times \mathbf{R}_{18}^p \mathbf{i}_{18}^{18}) + \mathbf{R}_{18}^p (\mathbf{R}_0^{18} \boldsymbol{\omega}_\psi^0 \times \mathbf{i}_{18}^{18})\end{aligned}$$

Desarrollando $\frac{d}{dt} \left(\frac{\partial L_c}{\partial \dot{q}_j} \right)$

Derivando la ec. (4.62) y agrupando se tiene:

$$\begin{aligned}\frac{d}{dt} \left(\frac{\partial L_c}{\partial \dot{q}_j} \right) &= \frac{d}{dt} \left(\frac{1}{2} \left(\frac{\partial \dot{\mathbf{q}}^T}{\partial \dot{q}_j} \mathbf{N}_5 \dot{\mathbf{q}} + \dot{\mathbf{q}}^T \mathbf{N}_5 \frac{\partial \dot{\mathbf{q}}}{\partial \dot{q}_j} \right) \right) \\ &= \frac{1}{2} \frac{\partial \dot{\mathbf{q}}^T}{\partial \dot{q}_j} (\mathbf{N}_5 + \mathbf{N}_5^T) \ddot{\mathbf{q}} + \frac{1}{2} \frac{\partial \dot{\mathbf{q}}^T}{\partial \dot{q}_j} (\dot{\mathbf{N}}_5 + \dot{\mathbf{N}}_5^T) \dot{\mathbf{q}} \\ &= \frac{\partial \dot{\mathbf{q}}^T}{\partial \dot{q}_j} \mathbf{N}_5 \ddot{\mathbf{q}} + \frac{\partial \dot{\mathbf{q}}^T}{\partial \dot{q}_j} \dot{\mathbf{N}}_5 \dot{\mathbf{q}}\end{aligned}$$

Finalmente:

$$\frac{d}{dt} \left(\frac{\partial L_c}{\partial \dot{q}_j} \right) = \mathbf{D}_{5j} \ddot{\mathbf{q}} + \mathbf{V}_{5j} \dot{\mathbf{q}} \quad (4.83)$$

Donde:

$$\begin{aligned}\mathbf{D}_{5j} &= \frac{\partial \dot{\mathbf{q}}^T}{\partial \dot{q}_j} \mathbf{N}_5 \\ \mathbf{V}_{5j} &= \frac{\partial \dot{\mathbf{q}}^T}{\partial \dot{q}_j} \dot{\mathbf{N}}_5\end{aligned} \quad (4.84)$$

Además:

$$\begin{aligned}\mathbf{N}_5 &= m_c \mathbf{M}_{11}^T \mathbf{M}_{11} + \mathbf{M}_{10}^T \mathbf{J}_{Gc} \mathbf{M}_{10} \\ \dot{\mathbf{N}}_5 &= m_c (\dot{\mathbf{M}}_{11}^T \mathbf{M}_{11} + \mathbf{M}_{11}^T \dot{\mathbf{M}}_{11}) + (\dot{\mathbf{M}}_{10}^T \mathbf{J}_{Gc} \mathbf{M}_{10} + \mathbf{M}_{10}^T \mathbf{J}_{Gc} \dot{\mathbf{M}}_{10})\end{aligned}$$

$$\mathbf{M}_{11} = [\mathbf{R}_0^p, \mathbf{k}_{15}, \mathbf{k}_{16}, \mathbf{k}_{17}]$$

$$\dot{\mathbf{M}}_{11} = [\dot{\mathbf{R}}_0^p, \dot{\mathbf{k}}_{15}, \dot{\mathbf{k}}_{16}, \dot{\mathbf{k}}_{17}]$$

$$\mathbf{k}_{15} = \mathbf{R}_0^p \mathbf{k}_0^0 \times \mathbf{r}_{Gc'}^p$$

$$\mathbf{k}_{16} = \mathbf{R}_{18}^p \mathbf{i}_{18}^{18} \times \mathbf{r}_{Gc'}^p$$

$$\mathbf{k}_{17} = \mathbf{k}_{19}^{19} \times \mathbf{r}_{Gc'}^p$$

$$\begin{aligned}
\dot{\mathbf{k}}_{15} &= \dot{\mathbf{R}}_0^p \mathbf{k}_0^0 \times \mathbf{r}_{Gc'}^p + \mathbf{R}_0^p \mathbf{k}_0^0 \times \dot{\mathbf{r}}_{Gc'}^p \\
&= \dot{\mathbf{R}}_0^p \mathbf{k}_0^0 \times \mathbf{r}_{Gc'}^p + \mathbf{R}_0^p \mathbf{k}_0^0 \times (\boldsymbol{\omega}_{Oc}^p \times \mathbf{r}_{Gc'}^p) \\
&= \dot{\mathbf{R}}_0^p \mathbf{k}_0^0 \times \mathbf{r}_{Gc'}^p + \mathbf{R}_0^p \mathbf{k}_0^0 \times \left((\mathbf{k}_{12} \dot{\psi} + \mathbf{k}_{13} \dot{\theta} + \mathbf{k}_{14} \dot{\phi}) \times \mathbf{r}_{Gc'}^p \right) \\
\dot{\mathbf{k}}_{16} &= \dot{\mathbf{R}}_{18}^p \mathbf{i}_{18}^{18} \times \mathbf{r}_{Gc'}^p + \mathbf{R}_{18}^p \mathbf{i}_{18}^{18} \times \mathbf{r}_{Gc'}^p + \mathbf{R}_{18}^p \mathbf{i}_{18}^{18} \times \dot{\mathbf{r}}_{Gc'}^p \\
&= \dot{\mathbf{R}}_{18}^p \mathbf{i}_{18}^{18} \times \mathbf{r}_{Gc'}^p + \mathbf{R}_{18}^p (\mathbf{R}_0^{18} \boldsymbol{\omega}_\psi^0 \times \mathbf{i}_{18}^{18}) \times \mathbf{r}_{Gc'}^p + \mathbf{R}_{18}^p \mathbf{i}_{18}^{18} \times (\boldsymbol{\omega}_{Oc}^p \times \mathbf{r}_{Gc'}^p) \\
&= \dot{\mathbf{R}}_{18}^p \mathbf{i}_{18}^{18} \times \mathbf{r}_{Gc'}^p + \mathbf{R}_{18}^p (\dot{\psi} \mathbf{k}_0^0 \times \mathbf{i}_{18}^{18}) \times \mathbf{r}_{Gc'}^p + \mathbf{R}_{18}^p \mathbf{i}_{18}^{18} \times \left((\mathbf{k}_{12} \dot{\psi} + \mathbf{k}_{13} \dot{\theta} + \mathbf{k}_{14} \dot{\phi}) \times \mathbf{r}_{Gc'}^p \right) \\
\dot{\mathbf{k}}_{17} &= \dot{\mathbf{k}}_{19}^{19} \times \mathbf{r}_{Gc'}^p + \mathbf{k}_{19}^{19} \times \dot{\mathbf{r}}_{Gc'}^p \\
&= \left((\mathbf{R}_0^{19} \boldsymbol{\omega}_\psi^0 + \mathbf{R}_{18}^{19} \boldsymbol{\omega}_\theta^{18}) \times \mathbf{k}_{19}^{19} \right) \times \mathbf{r}_{Gc'}^p + \mathbf{k}_{19}^{19} \times (\boldsymbol{\omega}_{Oc}^p \times \mathbf{r}_{Gc'}^p) \\
&= \left((\mathbf{R}_0^{19} \boldsymbol{\omega}_\psi^0 + \mathbf{R}_{18}^{19} \boldsymbol{\omega}_\theta^{18}) \times \mathbf{k}_{19}^{19} \right) \times \mathbf{r}_{Gc'}^p + \mathbf{k}_{19}^{19} \times \left((\mathbf{k}_{12} \dot{\psi} + \mathbf{k}_{13} \dot{\theta} + \mathbf{k}_{14} \dot{\phi}) \times \mathbf{r}_{Gc'}^p \right)
\end{aligned}$$

Reescribiendo $\dot{\mathbf{k}}_{16}$ y $\dot{\mathbf{k}}_{17}$ tomando en cuenta las ecs. (4.79) y (4.81):

$$\begin{aligned}
\dot{\mathbf{k}}_{15} &= (\boldsymbol{\omega}_{pO}^p \times \mathbf{R}_0^p \mathbf{k}_0^0) \times \mathbf{r}_{Gc'}^p + \mathbf{R}_0^p \mathbf{k}_0^0 \times \left((\mathbf{k}_{12} \dot{\psi} + \mathbf{k}_{13} \dot{\theta} + \mathbf{k}_{14} \dot{\phi}) \times \mathbf{r}_{Gc'}^p \right) \\
\dot{\mathbf{k}}_{16} &= (\boldsymbol{\omega}_{p18}^p \times \mathbf{R}_{18}^p \mathbf{i}_{18}^{18}) \times \mathbf{r}_{Gc'}^p + \mathbf{R}_{18}^p (\dot{\psi} \mathbf{k}_0^0 \times \mathbf{i}_{18}^{18}) \times \mathbf{r}_{Gc'}^p + \mathbf{R}_{18}^p \mathbf{i}_{18}^{18} \times \left((\mathbf{k}_{12} \dot{\psi} + \mathbf{k}_{13} \dot{\theta} + \mathbf{k}_{14} \dot{\phi}) \times \mathbf{r}_{Gc'}^p \right)
\end{aligned}$$

4.3.2. Desarrollo del Segundo Término de la Ecuación de Lagrange

Tomando la ec. (4.47) y aplicando la derivada parcial con respecto a la variable de coordenadas cartesianas:

$$\frac{\partial L}{\partial q_j} = \sum_{i=1}^6 \frac{\partial}{\partial q_j} (L_{1i} + L_{2i} + L_{3i}) + \frac{\partial L_p}{\partial q_j} + \frac{\partial L_c}{\partial q_j}$$

Desarrollando $\frac{\partial L_{1i}}{\partial q_j}$

L_{1i} se define como:

$$L_{1i} = \frac{1}{2} \left(m_{1i} (\mathbf{v}_{G1i}^{4i})^T \mathbf{v}_{G1i}^{4i} + (\boldsymbol{\omega}_{O1i}^{4i})^T \mathbf{J}_{G1i} \boldsymbol{\omega}_{O1i}^{4i} \right) + m_{1i} \mathbf{g}^T \mathbf{r}_{G1i}^{0i}$$

Simplificando:

$$L_{1i} = \frac{1}{2} (\dot{\mathbf{q}}^T \mathbf{N}_{1i} \dot{\mathbf{q}}) + m_{1i} \mathbf{g}^T \mathbf{r}_{G1i}^{0i}$$

Donde:

$$\mathbf{N}_{1i} = m_{1i} \mathbf{M}_{1i}^T \mathbf{M}_{1i} + \mathbf{M}_{2i}^T \mathbf{J}_{G1i} \mathbf{M}_{2i}$$

$$\mathbf{M}_{1i} = \mathbf{k}_{1i} \mathbf{k}_{2i}^T$$

$$\mathbf{M}_{2i} = \mathbf{j}_{4i}^{4i} \mathbf{k}_{2i}^T$$

$$\mathbf{k}_{1i} = \mathbf{j}_{4i}^{4i} \times \mathbf{r}_{G1i}^{4i}$$

$$\mathbf{k}_{2i}^T = \frac{1}{V_{1i}} [V_{2i}, V_{3i}, V_{4i}, V_{5i}, V_{6i}, V_{7i}]$$

Derivando respecto a q_j :

$$\begin{aligned}\frac{\partial L_{1i}}{\partial q_j} &= \frac{1}{2} \frac{\partial}{\partial q_j} (\dot{\mathbf{q}}^T \mathbf{N}_{1i} \dot{\mathbf{q}}) + \frac{\partial}{\partial q_j} (m_{1i} \mathbf{g}^T \mathbf{r}_{G1i}^0) \\ &= \frac{1}{2} \dot{\mathbf{q}}^T \frac{\partial \mathbf{N}_{1i}}{\partial q_j} \dot{\mathbf{q}} + m_{1i} \mathbf{g}^T \frac{\partial \mathbf{r}_{G1i}^0}{\partial q_j}\end{aligned}$$

Finalmente:

$$\frac{\partial L_{1i}}{\partial q_j} = V'_{1ij} \dot{\mathbf{q}} + C_{1ij} \quad (4.85)$$

Donde:

$$\begin{aligned}V'_{1ij} &= \frac{1}{2} \dot{\mathbf{q}}^T \frac{\partial \mathbf{N}_{1i}}{\partial q_j} \\ C_{1ij} &= m_{1i} \mathbf{g}^T \frac{\partial \mathbf{r}_{G1i}^0}{\partial q_j}\end{aligned} \quad (4.86)$$

A su vez:

$$\begin{aligned}\frac{\partial \mathbf{N}_{1i}}{\partial q_j} &= \frac{\partial}{\partial q_j} (m_{1i} \mathbf{M}_{1i}^T \mathbf{M}_{1i}) + \frac{\partial}{\partial q_j} (\mathbf{M}_{2i}^T \mathbf{J}_{G1i} \mathbf{M}_{2i}) \\ &= m_{1i} \left(\frac{\partial \mathbf{M}_{1i}^T}{\partial q_j} \mathbf{M}_{1i} + \mathbf{M}_{1i}^T \frac{\partial \mathbf{M}_{1i}}{\partial q_j} \right) + \left(\frac{\partial \mathbf{M}_{2i}^T}{\partial q_j} \mathbf{J}_{G1i} \mathbf{M}_{2i} + \mathbf{M}_{2i}^T \mathbf{J}_{G1i} \frac{\partial \mathbf{M}_{2i}}{\partial q_j} \right)\end{aligned}$$

$$\begin{aligned}\frac{\partial \mathbf{M}_{1i}}{\partial q_j} &= \frac{\partial \mathbf{k}_{1i}}{\partial q_j} \mathbf{k}_{2i}^T + \mathbf{k}_{1i} \frac{\partial \mathbf{k}_{2i}^T}{\partial q_j} \\ \frac{\partial \mathbf{M}_{2i}}{\partial q_j} &= \frac{\partial \mathbf{j}_{4i}^{4i}}{\partial q_j} \mathbf{k}_{2i}^T + \mathbf{j}_{4i}^{4i} \frac{\partial \mathbf{k}_{2i}^T}{\partial q_j}\end{aligned}$$

A continuación se procederá a derivar \mathbf{k}_{1i} , \mathbf{k}_{2i} y \mathbf{j}_{4i}^{4i} , respecto a q_j para ser utilizadas en las ecuaciones anteriores. A lo largo del procedimiento se presentarán dos tipos de vectores \mathbf{k}_i , los de tres y seis componentes, siendo ambos funciones de los ángulos $\theta_{4i}, \theta_{8i}, \theta_{9i}$. Con el fin de obtener las derivadas parciales respecto a q_j de los vectores de tres componentes, se hará uso de las derivadas parciales respecto al tiempo de los mismos para posteriormente multiplicar cada lado de estas últimas por $\frac{\partial t}{\partial q_j}$, tal como sigue, derivando respecto al tiempo:

$$\frac{\partial \mathbf{k}_m}{\partial t} = \frac{\partial \mathbf{k}_m}{\partial \theta_{4i}} \frac{\partial \theta_{4i}}{\partial t} + \frac{\partial \mathbf{k}_m}{\partial \theta_{8i}} \frac{\partial \theta_{8i}}{\partial t} + \frac{\partial \mathbf{k}_m}{\partial \theta_{9i}} \frac{\partial \theta_{9i}}{\partial t}$$

Ahora multiplicando por $\frac{\partial t}{\partial q_j}$:

$$\begin{aligned} \left(\frac{\partial \mathbf{k}_m}{\partial t}\right) \frac{\partial t}{\partial q_j} &= \left(\frac{\partial \mathbf{k}_m}{\partial \theta_{4i}} \frac{\partial \theta_{4i}}{\partial t}\right) \frac{\partial t}{\partial q_j} + \left(\frac{\partial \mathbf{k}_m}{\partial \theta_{8i}} \frac{\partial \theta_{8i}}{\partial t}\right) \frac{\partial t}{\partial q_j} + \left(\frac{\partial \mathbf{k}_m}{\partial \theta_{9i}} \frac{\partial \theta_{9i}}{\partial t}\right) \frac{\partial t}{\partial q_j} \\ \frac{\partial \mathbf{k}_m}{\partial q_j} &= \frac{\partial \mathbf{k}_m}{\partial \theta_{4i}} \frac{\partial \theta_{4i}}{\partial q_j} + \frac{\partial \mathbf{k}_m}{\partial \theta_{8i}} \frac{\partial \theta_{8i}}{\partial q_j} + \frac{\partial \mathbf{k}_m}{\partial \theta_{9i}} \frac{\partial \theta_{9i}}{\partial q_j} \end{aligned}$$

Finalmente agrupando de forma matricial:

$$\begin{aligned} \frac{\partial \mathbf{k}_m}{\partial q_j} &= \mathbf{J}_{n,3 \times 3} \frac{\partial \boldsymbol{\theta}_i}{\partial q_j} \quad (4.87) \\ \frac{\partial \boldsymbol{\theta}_i}{\partial q_j} &= \left[\frac{\partial \theta_{4i}}{\partial q_j}, \frac{\partial \theta_{8i}}{\partial q_j}, \frac{\partial \theta_{9i}}{\partial q_j} \right]^T \end{aligned}$$

Donde $\mathbf{J}_{n,3 \times 3}$ es una matriz de 3×3 y se obtiene factorizando los términos $\frac{\partial \theta_{4i}}{\partial q_j}, \frac{\partial \theta_{8i}}{\partial q_j}, \frac{\partial \theta_{9i}}{\partial q_j}$.

Por otro lado, para obtener las derivadas parciales respecto a q_j de los vectores de seis componentes se hará uso de la regla de la cadena, tal como sigue:

$$\begin{aligned} \frac{\partial \mathbf{k}_m}{\partial q_j} &= \frac{\partial \mathbf{k}_m}{\partial \theta_{4i}} \frac{\partial \theta_{4i}}{\partial q_j} + \frac{\partial \mathbf{k}_m}{\partial \theta_{8i}} \frac{\partial \theta_{8i}}{\partial q_j} + \frac{\partial \mathbf{k}_m}{\partial \theta_{9i}} \frac{\partial \theta_{9i}}{\partial q_j} + \frac{\partial \mathbf{k}'_m}{\partial q_j} \\ &= \mathbf{J}_{n,6 \times 3} \frac{\partial \boldsymbol{\theta}_i}{\partial q_j} + \frac{\partial \mathbf{k}'_m}{\partial q_j} \end{aligned}$$

Donde $\mathbf{J}_{n,6 \times 3}$ es una matriz de 6×3 , $\frac{\partial \boldsymbol{\theta}_i}{\partial q_j}$ es un vector de 3×1 y $\frac{\partial \mathbf{k}'_m}{\partial q_j}$ es un vector de 6×1 y es la derivada parcial del vector \mathbf{k}_m respecto a $x_p, y_p, z_p, \psi, \theta$ y ϕ según corresponda para j (no confundir con $\frac{\partial \mathbf{k}_m}{\partial q_j}$ que es la derivada parcial completa del vector \mathbf{k}_m respecto a q_j):

$$\begin{aligned} \mathbf{J}_n &= \left[\frac{\partial \mathbf{k}_m}{\partial \theta_{4i}}, \frac{\partial \mathbf{k}_m}{\partial \theta_{8i}}, \frac{\partial \mathbf{k}_m}{\partial \theta_{9i}} \right] \\ \frac{\partial \boldsymbol{\theta}_i}{\partial q_j} &= \left[\frac{\partial \theta_{4i}}{\partial q_j}, \frac{\partial \theta_{8i}}{\partial q_j}, \frac{\partial \theta_{9i}}{\partial q_j} \right]^T \end{aligned}$$

El vector $\mathbf{k}_{4i} = \mathbf{j}_{4i}^{4i} \times \mathbf{r}_{G1i'}^{4i}$ está definido en la base $4i$, por lo tanto, $\mathbf{j}_{4i}^{4i} = [0, 1, 0]^T$ y $\mathbf{r}_{G1i'}^{4i} = [x_{G1i'}, y_{G1i'}, z_{G1i'}]^T$ no se presentan como una función de θ_{4i} . De esta forma la derivada respecto a θ_{4i} aparenta ser cero. Sin embargo, físicamente, cuando el robot se mueve el vector $\mathbf{r}_{G1i'}^{4i}$ va cambiando su orientación, debido al ángulo θ_{4i} . Para poder encontrar su derivada respecto a q_j procedemos de la sig. manera.

Derivando \mathbf{k}_{1i} respecto al tiempo, se hace notar que es de tres componentes:

$$\begin{aligned}\frac{\partial \mathbf{k}_{1i}}{\partial t} &= \frac{\partial \mathbf{j}_{4i}^{4i}}{\partial t} \times \mathbf{r}_{G1i'}^{4i} + \mathbf{j}_{4i}^{4i} \times \frac{\partial \mathbf{r}_{G1i'}^{4i}}{\partial t} \\ &= \mathbf{j}_{4i}^{4i} \times \frac{\partial \mathbf{r}_{G1i'}^{4i}}{\partial t} \\ &= \mathbf{j}_{4i}^{4i} \times (\boldsymbol{\omega}_{4i}^{4i} \times \mathbf{r}_{G1i'}^{4i}) \\ \frac{\partial \mathbf{k}_{1i}}{\partial t} &= \mathbf{j}_{4i}^{4i} \times (\dot{\theta}_{4i} \mathbf{j}_{4i}^{4i} \times \mathbf{r}_{G1i'}^{4i})\end{aligned}$$

Multiplicando ambos lados de la ecuación por $\frac{\partial t}{\partial q_j}$:

$$\begin{aligned}\left(\frac{\partial \mathbf{k}_{1i}}{\partial t}\right) \frac{\partial t}{\partial q_j} &= \mathbf{j}_{4i}^{4i} \times \left(\frac{\partial \theta_{4i}}{\partial t} \mathbf{j}_{4i}^{4i} \times \mathbf{r}_{G1i'}^{4i}\right) \frac{\partial t}{\partial q_j} \\ \frac{\partial \mathbf{k}_{1i}}{\partial q_j} &= \mathbf{j}_{4i}^{4i} \times (\mathbf{j}_{4i}^{4i} \times \mathbf{r}_{G1i'}^{4i}) \frac{\partial \theta_{4i}}{\partial q_j}\end{aligned}\quad (4.88)$$

La demostración de la ec. (4.88) empleando matrices de rotación se encuentra en el apéndice E. Escribiendo matricialmente la ecuación anterior:

$$\frac{\partial \mathbf{k}_{1i}}{\partial q_j} = \mathbf{J}_{1i} \frac{\partial \boldsymbol{\theta}_i}{\partial q_j}$$

Donde:

$$\mathbf{J}_{1i} = [\mathbf{J}_{1i,1}, \mathbf{0}, \mathbf{0}] \quad \mathbf{J}_{1i,1} = \mathbf{j}_{4i}^{4i} \times (\mathbf{j}_{4i}^{4i} \times \mathbf{r}_{G1i'}^{4i})$$

Para $\frac{\partial \mathbf{k}_{2i}}{\partial q_j}$ se tiene, se hace notar que es de seis componentes:

$$\frac{\partial \mathbf{k}_{2i}}{\partial q_j} = \mathbf{J}_{2i} \frac{\partial \boldsymbol{\theta}_i}{\partial q_j} + \frac{\partial \mathbf{k}'_{2i}}{\partial q_j}\quad (4.89)$$

$$\mathbf{J}_{2i} = \left[\frac{\partial \mathbf{k}_{2i}}{\partial \theta_{4i}}, \mathbf{0}, \mathbf{0} \right]$$

$$\frac{\partial \mathbf{k}_{2i}}{\partial \theta_{4i}} = \frac{\partial}{\partial \theta_{4i}} \left(\frac{1}{V_{1i}} [V_{2i}, V_{3i}, V_{4i}, V_{5i}, V_{6i}, V_{7i}]^T \right)$$

$$\frac{\partial \mathbf{k}'_{2i}}{\partial q_j} = \frac{\partial}{\partial q_j} \left(\frac{1}{V_{1i}} [V_{2i}, V_{3i}, V_{4i}, V_{5i}, V_{6i}, V_{7i}]^T \right)$$

Para obtener $\frac{\partial \mathbf{j}_{4i}^{4i}}{\partial q_j}$, nos basaremos en la premisa de que cualquier vector asociado a algún

elemento del robot que no varíe respecto al tiempo, tampoco presentará variación respecto a cualquier otra variable del robot. De esta forma se tiene:

$$\frac{\partial \mathbf{j}_{4i}^{4i}}{\partial q_j} = \mathbf{0}\quad (4.90)$$

Para obtener $\frac{\partial \mathbf{r}_{G1i}^{0i}}{\partial q_j}$ se parte de la ec. (3.5):

$$\mathbf{v}_{G1i}^0 = \boldsymbol{\omega}_{O1i}^0 \times \mathbf{r}_{G1i'}^0$$

$$\begin{aligned} \frac{\partial \mathbf{r}_{G1i}^0}{\partial t} &= \boldsymbol{\omega}_{O1i}^0 \times \mathbf{r}_{G1i'}^0 \\ &= \mathbf{R}_{4i}^0 \boldsymbol{\omega}_{1i}^{4i} \times \mathbf{R}_{4i}^0 \mathbf{r}_{G1i'}^{4i} \end{aligned}$$

$$\frac{\partial \mathbf{r}_{G1i}^0}{\partial t} = \mathbf{R}_{4i}^0 \left(\dot{\theta}_{4i} \mathbf{j}_{4i}^{4i} \times \mathbf{r}_{G1i'}^{4i} \right)$$

Multiplicando ambos lados de la ecuación anterior por $\frac{\partial t}{\partial q_j}$, semejante al procedimiento realizado para obtener la ec. (4.88):

$$\frac{\partial \mathbf{r}_{G1i}^0}{\partial q_j} = \mathbf{R}_{4i}^0 \left(\mathbf{j}_{4i}^{4i} \times \mathbf{r}_{G1i'}^{4i} \right) \frac{\partial \theta_{4i}}{\partial q_j} \quad (4.91)$$

Escribiendo matricialmente la ecuación anterior:

$$\frac{\partial \mathbf{r}_{G1i}^{0i}}{\partial q_j} = \mathbf{J}_{3i} \frac{\partial \boldsymbol{\theta}_i}{\partial q_j}$$

Donde:

$$\mathbf{J}_{3i} = [\mathbf{J}_{3i,1}, \mathbf{0}, \mathbf{0}]$$

$$\mathbf{J}_{3i,1} = \mathbf{R}_{4i}^0 \left(\mathbf{j}_{4i}^{4i} \times \mathbf{r}_{G1i'}^{4i} \right)$$

Desarrollando $\frac{\partial L_{2i}}{\partial q_j}$

L_{2i} se define como:

$$L_{2i} = \frac{1}{2} \left(m_{2i} \left(\mathbf{v}_{G2i}^{6i} \right)^T \mathbf{v}_{G2i}^{6i} + \left(\boldsymbol{\omega}_{O2i}^{6i} \right)^T \mathbf{J}_{G2i} \boldsymbol{\omega}_{O2i}^{6i} \right) + m_{2i} \mathbf{g}^T \mathbf{r}_{G2i}^0$$

Simplificando:

$$L_{2i} = \frac{1}{2} \left(\dot{\mathbf{q}}^T \mathbf{N}_{2i} \dot{\mathbf{q}} \right) + m_{2i} \mathbf{g}^T \mathbf{r}_{G2i}^0$$

Donde:

$$\begin{aligned}
 \mathbf{N}_{2i} &= m_{2i} \mathbf{M}_{3i}^T \mathbf{M}_{3i} + \mathbf{M}_{5i}^T \mathbf{J}_{G2i} \mathbf{M}_{5i} \\
 \mathbf{M}_{3i} &= \mathbf{k}_{3i} \mathbf{k}_{2i}^T \\
 \mathbf{M}_{5i} &= \mathbf{R}_{4i}^{6i} \mathbf{M}_{2i} + \mathbf{M}_{4i} \\
 \mathbf{M}_{4i} &= \mathbf{i}_{6i}^{6i} \mathbf{k}_{4i}^T \\
 \mathbf{k}_{3i} &= \mathbf{R}_{4i}^{6i} \left(\mathbf{j}_{4i}^{4i} \times \mathbf{r}_{4i}^{4i} \right) \\
 \mathbf{k}_{4i}^T &= \frac{1}{V_{8i}} [E_{1i}, E_{2i}, E_{3i}, E_{4i}, E_{5i}, E_{6i}]
 \end{aligned}$$

Derivando respecto a q_j :

$$\begin{aligned}
 \frac{\partial L_{2i}}{\partial q_j} &= \frac{1}{2} \frac{\partial}{\partial q_j} (\dot{\mathbf{q}}^T \mathbf{N}_{2i} \dot{\mathbf{q}}) + \frac{\partial}{\partial q_j} (m_{2i} \mathbf{g}^T \mathbf{r}_{G2i}^0) \\
 &= \frac{1}{2} \dot{\mathbf{q}}^T \frac{\partial \mathbf{N}_{2i}}{\partial q_j} \dot{\mathbf{q}} + m_{2i} \mathbf{g}^T \frac{\partial \mathbf{r}_{G2i}^0}{\partial q_j}
 \end{aligned}$$

Finalmente:

$$\frac{\partial L_{2i}}{\partial q_j} = V'_{2ij} \dot{\mathbf{q}} + C_{2ij} \quad (4.92)$$

Donde:

$$\begin{aligned}
 V'_{2ij} &= \frac{1}{2} \dot{\mathbf{q}}^T \frac{\partial \mathbf{N}_{2i}}{\partial q_j} \\
 C_{2ij} &= m_{2i} \mathbf{g}^T \frac{\partial \mathbf{r}_{G2i}^0}{\partial q_j}
 \end{aligned} \quad (4.93)$$

A su vez:

$$\begin{aligned}
 \frac{\partial \mathbf{N}_{2i}}{\partial q_j} &= \frac{\partial}{\partial q_j} (m_{2i} \mathbf{M}_{3i}^T \mathbf{M}_{3i}) + \frac{\partial}{\partial q_j} (\mathbf{M}_{5i}^T \mathbf{J}_{G2i} \mathbf{M}_{5i}) \\
 &= m_{2i} \left(\frac{\partial \mathbf{M}_{3i}^T}{\partial q_j} \mathbf{M}_{3i} + \mathbf{M}_{3i}^T \frac{\partial \mathbf{M}_{3i}}{\partial q_j} \right) + \left(\frac{\partial \mathbf{M}_{5i}^T}{\partial q_j} \mathbf{J}_{G2i} \mathbf{M}_{5i} + \mathbf{M}_{5i}^T \mathbf{J}_{G2i} \frac{\partial \mathbf{M}_{5i}}{\partial q_j} \right) \\
 \frac{\partial \mathbf{M}_{3i}}{\partial q_j} &= \frac{\partial \mathbf{k}_{3i}}{\partial q_j} \mathbf{k}_{2i}^T + \mathbf{k}_{3i} \frac{\partial \mathbf{k}_{2i}^T}{\partial q_j} \\
 \frac{\partial \mathbf{M}_{5i}}{\partial q_j} &= \mathbf{R}_{4i}^{6i} \frac{\partial \mathbf{M}_{2i}}{\partial q_j} + \frac{\partial \mathbf{M}_{4i}}{\partial q_j} \\
 \frac{\partial \mathbf{M}_{4i}}{\partial q_j} &= \frac{\partial \mathbf{i}_{6i}^{6i}}{\partial q_j} \mathbf{k}_{4i}^T + \mathbf{i}_{6i}^{6i} \frac{\partial \mathbf{k}_{4i}^T}{\partial q_j}
 \end{aligned}$$

Para obtener el término $\frac{\partial \mathbf{k}_{3i}}{\partial q_j}$ se tiene:

$$\begin{aligned}\frac{\partial \mathbf{k}_{3i}}{\partial t} &= \mathbf{R}_{4i}^{6i} \left(\mathbf{j}_{4i}^{4i} \times \left(\dot{\theta}_{4i} \mathbf{j}_{4i}^{4i} \times \mathbf{r}_{4i}^{4i} \right) \right) \\ &= \mathbf{R}_{4i}^{6i} \left(\mathbf{j}_{4i}^{4i} \times \left(\frac{\partial \theta_{4i}}{\partial t} \mathbf{j}_{4i}^{4i} \times \mathbf{r}_{4i}^{4i} \right) \right)\end{aligned}$$

Donde la derivada respecto al tiempo de $\mathbf{R}_{6i}^{4i} \mathbf{r}_{G2i'}^{6i}$ es el vector cero, ya que \mathbf{R}_{6i}^{4i} solo tiene un ángulo constante δ_{6i} y $\mathbf{r}_{G2i'}^{6i}$ no cambia de magnitud ni dirección cuando el robot se mueve.

Multiplicando ambos lados de la ecuación anterior por $\frac{\partial t}{\partial q_j}$:

$$\frac{\partial \mathbf{k}_{3i}}{\partial q_j} = \mathbf{R}_{4i}^{6i} \left(\mathbf{j}_{4i}^{4i} \times \left(\mathbf{j}_{4i}^{4i} \times \mathbf{r}_{4i}^{4i} \right) \right) \frac{\partial \theta_{4i}}{\partial q_j} \quad (4.94)$$

Matricialmente:

$$\frac{\partial \mathbf{k}_{3i}}{\partial q_j} = \mathbf{J}_{4i} \frac{\partial \theta_i}{\partial q_j}$$

Donde:

$$\mathbf{J}_{4i} = [\mathbf{J}_{4i,1}, \mathbf{0}, \mathbf{0}]$$

$$\mathbf{J}_{4i,1} = \mathbf{R}_{4i}^{6i} \left(\mathbf{j}_{4i}^{4i} \times \left(\mathbf{j}_{4i}^{4i} \times \mathbf{r}_{4i}^{4i} \right) \right)$$

Para obtener el término $\frac{\partial \mathbf{k}_{4i}}{\partial q_j}$:

$$\begin{aligned}\frac{\partial \mathbf{k}_{4i}}{\partial q_j} &= \mathbf{J}_{5i} \frac{\partial \theta_i}{\partial q_j} + \frac{\partial \mathbf{k}'_{4i}}{\partial q_j} \\ \mathbf{J}_{5i} &= \left[\frac{\partial \mathbf{k}_{4i}}{\partial \theta_{4i}}, \frac{\partial \mathbf{k}_{4i}}{\partial \theta_{8i}}, \mathbf{0} \right]\end{aligned} \quad (4.95)$$

$$\frac{\partial \mathbf{k}_{4i}}{\partial \theta_{4i}} = \frac{\partial}{\partial \theta_{4i}} \left(\frac{1}{V_{8i}} [E_{1i}, E_{2i}, E_{3i}, E_{4i}, E_{5i}, E_{6i}]^T \right)$$

$$\frac{\partial \mathbf{k}_{4i}}{\partial \theta_{8i}} = \frac{\partial}{\partial \theta_{8i}} \left(\frac{1}{V_{8i}} [E_{1i}, E_{2i}, E_{3i}, E_{4i}, E_{5i}, E_{6i}]^T \right)$$

$$\frac{\partial \mathbf{k}'_{4i}}{\partial q_j} = \frac{\partial}{\partial q_j} \left(\frac{1}{V_{8i}} [E_{1i}, E_{2i}, E_{3i}, E_{4i}, E_{5i}, E_{6i}]^T \right)$$

Para obtener el término $\frac{\partial \mathbf{i}_{6i}^{6i}}{\partial q_j}$, sabemos que $\frac{\partial \mathbf{i}_{6i}^{6i}}{\partial t} = \mathbf{0}$, haciendo una analogía a lo realizado para

\mathbf{j}_{4i}^{4i} se tiene:

$$\frac{\partial \mathbf{i}_{6i}^{6i}}{\partial q_j} = \mathbf{0} \quad (4.96)$$

Para obtener el término $\frac{\partial \mathbf{r}_{G2i}^0}{\partial q_j}$, se parte de la ec. (3.18):

$$\mathbf{v}_{G2i}^0 = \boldsymbol{\omega}_{O1i}^0 \times \mathbf{r}_{4i}^0 + \boldsymbol{\omega}_{O2i}^0 \times \mathbf{r}_{G2i'}^0$$

Se tiene:

$$\begin{aligned} \frac{\partial \mathbf{r}_{G2i}^0}{\partial t} &= \boldsymbol{\omega}_{O1i}^0 \times \mathbf{r}_{4i}^0 + \boldsymbol{\omega}_{O2i}^0 \times \mathbf{r}_{G2i'}^0 \\ &= \mathbf{R}_{4i}^0 \boldsymbol{\omega}_{1i}^{4i} \times \mathbf{R}_{4i}^0 \mathbf{r}_{4i}^{4i} + (\mathbf{R}_{4i}^0 \boldsymbol{\omega}_{1i}^{4i} + \mathbf{R}_{8i}^0 \boldsymbol{\omega}_{2i}^{8i}) \times \mathbf{r}_{G2i'}^0 \\ \frac{\partial \mathbf{r}_{G2i}^0}{\partial t} &= \mathbf{R}_{4i}^0 \left(\dot{\theta}_{4i} \mathbf{j}_{4i}^{4i} \times \mathbf{r}_{4i}^{4i} \right) \end{aligned}$$

En la expresión anterior, el término $(\mathbf{R}_{4i}^0 \boldsymbol{\omega}_{1i}^{4i} + \mathbf{R}_{8i}^0 \boldsymbol{\omega}_{2i}^{8i}) \times \mathbf{r}_{G2i'}^0$, es el vector cero, debido a que $\mathbf{R}_{4i}^0 \boldsymbol{\omega}_{1i}^{4i}$, $\mathbf{R}_{8i}^0 \boldsymbol{\omega}_{2i}^{8i}$ y $\mathbf{r}_{G2i'}^0$ son vectores paralelos.

Multiplicando ambos lados de la ecuación anterior por $\frac{\partial t}{\partial q_j}$, semejante al procedimiento realizado para obtener la ec. (4.88):

$$\frac{\partial \mathbf{r}_{G2i}^0}{\partial q_j} = \mathbf{R}_{4i}^0 \left(\mathbf{j}_{4i}^{4i} \times \mathbf{r}_{4i}^{4i} \right) \frac{\partial \theta_{4i}}{\partial q_j} \quad (4.97)$$

Matricialmente:

$$\frac{\partial \mathbf{r}_{G2i}^0}{\partial q_j} = \mathbf{J}_{6i} \frac{\partial \boldsymbol{\theta}_i}{\partial q_j}$$

Donde:

$$\mathbf{J}_{6i} = [\mathbf{J}_{6i,1}, \mathbf{0}, \mathbf{0}]$$

$$\mathbf{J}_{6i,1} = \mathbf{R}_{4i}^0 \left(\mathbf{j}_{4i}^{4i} \times \mathbf{r}_{4i}^{4i} \right)$$

Desarrollando $\frac{\partial L_{3i}}{\partial q_j}$

L_{3i} se define como:

$$L_{3i} = \frac{1}{2} \left(m_{3i} \left(\mathbf{v}_{G3i}^{9i} \right)^T \mathbf{v}_{G3i}^{9i} + \left(\boldsymbol{\omega}_{O3i}^{9i} \right)^T \mathbf{J}_{G3i} \boldsymbol{\omega}_{O3i}^{9i} \right) + m_{3i} \mathbf{g}^T \mathbf{r}_{G3i}^0$$

Simplificando:

$$L_{3i} = \frac{1}{2} \left(\dot{\mathbf{q}}^T \mathbf{N}_{3i} \dot{\mathbf{q}} \right) + m_{3i} \mathbf{g}^T \mathbf{r}_{G3i}^0$$

Donde:

$$\mathbf{N}_{3i} = m_{3i} \mathbf{M}_{6i}^T \mathbf{M}_{6i} + \mathbf{M}_{8i}^T \mathbf{J}_{G3i} \mathbf{M}_{8i}$$

$$\mathbf{M}_{6i} = \mathbf{k}_{5i} \mathbf{k}_{2i}^T + \mathbf{k}_{6i} \mathbf{k}_{4i}^T + \mathbf{k}_{7i} \mathbf{k}_{8i}^T$$

$$\mathbf{M}_{8i} = \mathbf{R}_{4i}^{9i} \mathbf{M}_{2i} + \mathbf{R}_{8i}^{9i} \mathbf{M}_{4i} + \mathbf{M}_{7i}$$

$$\mathbf{M}_{7i} = \mathbf{J}_{9i}^{9i} \mathbf{k}_{8i}^T$$

$$\mathbf{k}_{5i} = \mathbf{R}_{4i}^{9i} \mathbf{J}_{4i}^{4i} \times (\mathbf{r}_{4i}^{9i} + \mathbf{r}_{G3i'}^{9i})$$

$$\mathbf{k}_{6i} = \mathbf{R}_{8i}^{9i} \mathbf{J}_{8i}^{8i} \times \mathbf{r}_{G3i'}^{9i}$$

$$\mathbf{k}_{7i} = \mathbf{J}_{9i}^{9i} \times \mathbf{r}_{G3i'}^{9i}$$

$$\mathbf{k}_{8i}^T = \frac{1}{V_{16i}} [E_{7i}, E_{8i}, E_{9i}, E_{10i}, E_{11i}, E_{12i}]$$

Derivando respecto a q_j :

$$\begin{aligned} \frac{\partial L_{3i}}{\partial q_j} &= \frac{1}{2} \frac{\partial}{\partial q_j} (\dot{\mathbf{q}}^T \mathbf{N}_{3i} \dot{\mathbf{q}}) + \frac{\partial}{\partial q_j} (m_{3i} \mathbf{g}^T \mathbf{r}_{G3i}^0) \\ &= \frac{1}{2} \dot{\mathbf{q}}^T \frac{\partial \mathbf{N}_{3i}}{\partial q_j} \dot{\mathbf{q}} + m_{3i} \mathbf{g}^T \frac{\partial \mathbf{r}_{G3i}^0}{\partial q_j} \end{aligned}$$

Finalmente:

$$\frac{\partial L_{3i}}{\partial q_j} = V'_{3ij} \dot{\mathbf{q}} + C_{3ij} \quad (4.98)$$

Donde:

$$\begin{aligned} V'_{3ij} &= \frac{1}{2} \dot{\mathbf{q}}^T \frac{\partial \mathbf{N}_{3i}}{\partial q_j} \\ C_{3ij} &= m_{3i} \mathbf{g}^T \frac{\partial \mathbf{r}_{G3i}^0}{\partial q_j} \end{aligned} \quad (4.99)$$

A su vez:

$$\begin{aligned} \frac{\partial \mathbf{N}_{3i}}{\partial q_j} &= \frac{\partial}{\partial q_j} (m_{3i} \mathbf{M}_{6i}^T \mathbf{M}_{6i}) + \frac{\partial}{\partial q_j} (\mathbf{M}_{8i}^T \mathbf{J}_{G3i} \mathbf{M}_{8i}) \\ &= m_{3i} \left(\frac{\partial \mathbf{M}_{6i}^T}{\partial q_j} \mathbf{M}_{6i} + \mathbf{M}_{6i}^T \frac{\partial \mathbf{M}_{6i}}{\partial q_j} \right) + \left(\frac{\partial \mathbf{M}_{8i}^T}{\partial q_j} \mathbf{J}_{G3i} \mathbf{M}_{8i} + \mathbf{M}_{8i}^T \mathbf{J}_{G3i} \frac{\partial \mathbf{M}_{8i}}{\partial q_j} \right) \end{aligned}$$

$$\frac{\partial \mathbf{M}_{6i}}{\partial q_j} = \frac{\partial \mathbf{k}_{5i}}{\partial q_j} \mathbf{k}_{2i}^T + \mathbf{k}_{5i} \frac{\partial \mathbf{k}_{2i}^T}{\partial q_j} + \frac{\partial \mathbf{k}_{6i}}{\partial q_j} \mathbf{k}_{4i}^T + \mathbf{k}_{6i} \frac{\partial \mathbf{k}_{4i}^T}{\partial q_j} + \frac{\partial \mathbf{k}_{7i}}{\partial q_j} \mathbf{k}_{8i}^T + \mathbf{k}_{7i} \frac{\partial \mathbf{k}_{8i}^T}{\partial q_j}$$

$$\begin{aligned}
\frac{\partial M_{8i}}{\partial q_j} &= \frac{\partial R_{4i}^{9i}}{\partial q_j} M_{2i} + R_{4i}^{9i} \frac{\partial M_{2i}}{\partial q_j} + \frac{\partial R_{8i}^{9i}}{\partial q_j} M_{4i} + R_{8i}^{9i} \frac{\partial M_{4i}}{\partial q_j} + \frac{\partial M_{7i}}{\partial q_j} \\
&= \frac{\partial R_{4i}^{9i}}{\partial q_j} (\mathbf{j}_{4i}^{4i} \mathbf{k}_{2i}^T) + R_{4i}^{9i} \frac{\partial M_{2i}}{\partial q_j} + \frac{\partial R_{8i}^{9i}}{\partial q_j} (\mathbf{i}_{6i}^{6i} \mathbf{k}_{4i}^T) + R_{8i}^{9i} \frac{\partial M_{4i}}{\partial q_j} + \frac{\partial M_{7i}}{\partial q_j} \\
&= \frac{\partial R_{4i}^{9i} \mathbf{j}_{4i}^{4i}}{\partial q_j} \mathbf{k}_{2i}^T + R_{4i}^{9i} \frac{\partial M_{2i}}{\partial q_j} + \frac{\partial R_{8i}^{9i} \mathbf{i}_{6i}^{6i}}{\partial q_j} \mathbf{k}_{4i}^T + R_{8i}^{9i} \frac{\partial M_{4i}}{\partial q_j} + \frac{\partial M_{7i}}{\partial q_j} \\
\frac{\partial M_{7i}}{\partial q_j} &= \frac{\partial \mathbf{j}_{9i}^{9i}}{\partial q_j} \mathbf{k}_{8i}^T + \mathbf{j}_{9i}^{9i} \frac{\partial \mathbf{k}_{8i}^T}{\partial q_j}
\end{aligned}$$

Para obtener el término $\frac{\partial \mathbf{k}_{5i}}{\partial q_j}$, se obtiene la derivada de \mathbf{k}_{5i} respecto al tiempo:

$$\begin{aligned}
\frac{\partial \mathbf{k}_{5i}}{\partial t} &= (\boldsymbol{\omega}_{9i}^{9i} \times \mathbf{R}_{4i}^{9i} \mathbf{j}_{4i}^{4i}) \times (\mathbf{r}_{4i}^{9i} + \mathbf{r}_{G3i'}^{9i}) + \mathbf{R}_{4i}^{9i} \mathbf{j}_{4i}^{4i} \times (\mathbf{k}_{5i} \dot{\theta}_{4i} + \mathbf{k}_{6i} \dot{\theta}_{8i} + \mathbf{k}_{7i} \dot{\theta}_{9i}) \\
&= ((-\mathbf{R}_{8i}^{9i} \dot{\theta}_{8i} \mathbf{i}_{8i}^{8i} - \dot{\theta}_{9i} \mathbf{j}_{9i}^{9i}) \times \mathbf{R}_{4i}^{9i} \mathbf{j}_{4i}^{4i}) \times (\mathbf{r}_{4i}^{9i} + \mathbf{r}_{G3i'}^{9i}) + \mathbf{R}_{4i}^{9i} \mathbf{j}_{4i}^{4i} \times (\mathbf{k}_{5i} \dot{\theta}_{4i} + \mathbf{k}_{6i} \dot{\theta}_{8i} + \mathbf{k}_{7i} \dot{\theta}_{9i}) \\
&= (-\dot{\theta}_{9i} \mathbf{j}_{9i}^{9i} \times \mathbf{R}_{4i}^{9i} \mathbf{j}_{4i}^{4i}) \times (\mathbf{r}_{4i}^{9i} + \mathbf{r}_{G3i'}^{9i}) + \mathbf{R}_{4i}^{9i} \mathbf{j}_{4i}^{4i} \times (\mathbf{k}_{5i} \dot{\theta}_{4i} + \mathbf{k}_{6i} \dot{\theta}_{8i} + \mathbf{k}_{7i} \dot{\theta}_{9i}) \\
\frac{\partial \mathbf{k}_{5i}}{\partial t} &= \left(-\frac{\partial \theta_{9i}}{\partial t} \mathbf{j}_{9i}^{9i} \times \mathbf{R}_{4i}^{9i} \mathbf{j}_{4i}^{4i} \right) \times (\mathbf{r}_{4i}^{9i} + \mathbf{r}_{G3i'}^{9i}) + \mathbf{R}_{4i}^{9i} \mathbf{j}_{4i}^{4i} \times \left(\mathbf{k}_{5i} \frac{\partial \theta_{4i}}{\partial t} + \mathbf{k}_{6i} \frac{\partial \theta_{8i}}{\partial t} + \mathbf{k}_{7i} \frac{\partial \theta_{9i}}{\partial t} \right)
\end{aligned}$$

Multiplicando ambos lados de la ecuación anterior por $\frac{\partial t}{\partial q_j}$ con el fin de obtener $\frac{\partial \mathbf{k}_{5i}}{\partial q_j}$ y

agrupando:

$$\begin{aligned}
\frac{\partial \mathbf{k}_{5i}}{\partial q_j} &= \left(-\frac{\theta_{9i}}{\partial q_j} \mathbf{j}_{9i}^{9i} \times \mathbf{R}_{4i}^{9i} \mathbf{j}_{4i}^{4i} \right) \times (\mathbf{r}_{4i}^{9i} + \mathbf{r}_{G3i'}^{9i}) + \mathbf{R}_{4i}^{9i} \mathbf{j}_{4i}^{4i} \times \mathbf{k}_{5i} \frac{\partial \theta_{4i}}{\partial q_j} + \mathbf{R}_{4i}^{9i} \mathbf{j}_{4i}^{4i} \times \mathbf{k}_{6i} \frac{\partial \theta_{8i}}{\partial q_j} + \mathbf{R}_{4i}^{9i} \mathbf{j}_{4i}^{4i} \times \mathbf{k}_{7i} \frac{\partial \theta_{9i}}{\partial q_j} \\
\frac{\partial \mathbf{k}_{5i}}{\partial q_j} &= (\mathbf{R}_{4i}^{9i} \mathbf{j}_{4i}^{4i} \times \mathbf{k}_{5i}) \frac{\partial \theta_{4i}}{\partial q_j} + (\mathbf{R}_{4i}^{9i} \mathbf{j}_{4i}^{4i} \times \mathbf{k}_{6i}) \frac{\partial \theta_{8i}}{\partial q_j} + (\mathbf{R}_{4i}^{9i} \mathbf{j}_{4i}^{4i} \times \mathbf{k}_{7i} + (-\mathbf{j}_{9i}^{9i} \times \mathbf{R}_{4i}^{9i} \mathbf{j}_{4i}^{4i}) \times (\mathbf{r}_{4i}^{9i} + \mathbf{r}_{G3i'}^{9i})) \frac{\partial \theta_{9i}}{\partial q_j} \quad (4.100)
\end{aligned}$$

Acomodando de forma matricial la ec. (4.100) se tiene:

$$\frac{\partial \mathbf{k}_{5i}}{\partial q_j} = \mathbf{J}_{7i} \frac{\partial \boldsymbol{\theta}_i}{\partial q_j}$$

Donde:

$$\mathbf{J}_{7i} = [\mathbf{J}_{7i,1}, \mathbf{J}_{7i,2}, \mathbf{J}_{7i,3}]$$

$$\mathbf{J}_{7i,1} = \mathbf{R}_{4i}^{9i} \mathbf{j}_{4i}^{4i} \times \mathbf{k}_{5i}$$

$$\mathbf{J}_{7i,2} = \mathbf{R}_{4i}^{9i} \mathbf{j}_{4i}^{4i} \times \mathbf{k}_{6i}$$

$$\mathbf{J}_{7i,3} = \mathbf{R}_{4i}^{9i} \mathbf{j}_{4i}^{4i} \times \mathbf{k}_{7i} + (-\mathbf{j}_{9i}^{9i} \times \mathbf{R}_{4i}^{9i} \mathbf{j}_{4i}^{4i}) \times (\mathbf{r}_{4i}^{9i} + \mathbf{r}_{G3i'}^{9i})$$

Para obtener el término $\frac{\partial \mathbf{k}_{6i}}{\partial q_j}$, se obtiene la derivada de \mathbf{k}_{6i} respecto al tiempo:

$$\begin{aligned}
\frac{\mathbf{k}_{6i}}{\partial t} &= (\boldsymbol{\omega}_{9i}^{9i} \times \mathbf{R}_{8i}^{9i} \mathbf{i}_{8i}^{8i}) \times \mathbf{r}_{G3i'}^{9i} + \mathbf{R}_{8i}^{9i} \mathbf{i}_{8i}^{8i} \times \left(\left(\mathbf{R}_{4i}^{9i} \mathbf{j}_{4i}^{4i} \dot{\theta}_{4i} \right) + \mathbf{R}_{8i}^{9i} \mathbf{i}_{8i}^{8i} \dot{\theta}_{8i} \right) + \left(\mathbf{j}_{9i}^{9i} \dot{\theta}_{9i} \right) \times \mathbf{r}_{G3i'}^{9i} \\
&= \left(-\dot{\theta}_{9i} \mathbf{j}_{9i}^{9i} \right) \times \mathbf{R}_{8i}^{9i} \mathbf{i}_{8i}^{8i} \times \mathbf{r}_{G3i'}^{9i} + \mathbf{R}_{8i}^{9i} \mathbf{i}_{8i}^{8i} \times \left(\left(\mathbf{R}_{4i}^{9i} \mathbf{j}_{4i}^{4i} \dot{\theta}_{4i} + \mathbf{R}_{8i}^{9i} \mathbf{i}_{8i}^{8i} \dot{\theta}_{8i} + \mathbf{j}_{9i}^{9i} \dot{\theta}_{9i} \right) \times \mathbf{r}_{G3i'}^{9i} \right) \\
&= \left(-\frac{\theta_{9i}}{\partial t} \mathbf{j}_{9i}^{9i} \times \mathbf{R}_{8i}^{9i} \mathbf{i}_{8i}^{8i} \right) \times \mathbf{r}_{G3i'}^{9i} + \mathbf{R}_{8i}^{9i} \mathbf{i}_{8i}^{8i} \times \left(\left(\mathbf{R}_{4i}^{9i} \mathbf{j}_{4i}^{4i} \frac{\theta_{4i}}{\partial t} + \mathbf{R}_{8i}^{9i} \mathbf{i}_{8i}^{8i} \frac{\theta_{8i}}{\partial t} + \mathbf{j}_{9i}^{9i} \frac{\theta_{9i}}{\partial t} \right) \times \mathbf{r}_{G3i'}^{9i} \right)
\end{aligned}$$

Multiplicando ambos lados de la ecuación anterior por $\frac{\partial t}{\partial q_j}$ con el fin de obtener $\frac{\partial \mathbf{k}_{6i}}{\partial q_j}$ y

agrupando:

$$\begin{aligned}
\frac{\mathbf{k}_{6i}}{\partial q_j} &= \left(-\frac{\theta_{9i}}{\partial q_j} \mathbf{j}_{9i}^{9i} \times \mathbf{R}_{8i}^{9i} \mathbf{i}_{8i}^{8i} \right) \times \mathbf{r}_{G3i'}^{9i} + \mathbf{R}_{8i}^{9i} \mathbf{i}_{8i}^{8i} \times \left(\left(\mathbf{R}_{4i}^{9i} \mathbf{j}_{4i}^{4i} \frac{\theta_{4i}}{\partial q_j} + \mathbf{R}_{8i}^{9i} \mathbf{i}_{8i}^{8i} \frac{\theta_{8i}}{\partial q_j} + \mathbf{j}_{9i}^{9i} \frac{\theta_{9i}}{\partial q_j} \right) \times \mathbf{r}_{G3i'}^{9i} \right) \\
&= \left(-\mathbf{j}_{9i}^{9i} \frac{\theta_{9i}}{\partial q_j} \times \mathbf{R}_{8i}^{9i} \mathbf{i}_{8i}^{8i} \right) \times \mathbf{r}_{G3i'}^{9i} + \mathbf{R}_{8i}^{9i} \mathbf{i}_{8i}^{8i} \times \left(\mathbf{R}_{4i}^{9i} \mathbf{j}_{4i}^{4i} \frac{\theta_{4i}}{\partial q_j} \times \mathbf{r}_{G3i'}^{9i} \right) + \\
&\quad \mathbf{R}_{8i}^{9i} \mathbf{i}_{8i}^{8i} \times \left(\mathbf{R}_{8i}^{9i} \mathbf{i}_{8i}^{8i} \frac{\theta_{8i}}{\partial q_j} \times \mathbf{r}_{G3i'}^{9i} \right) + \mathbf{R}_{8i}^{9i} \mathbf{i}_{8i}^{8i} \times \left(\mathbf{j}_{9i}^{9i} \frac{\theta_{9i}}{\partial q_j} \times \mathbf{r}_{G3i'}^{9i} \right)
\end{aligned}$$

$$\begin{aligned}
\frac{\mathbf{k}_{6i}}{\partial q_j} &= \left(\mathbf{R}_{8i}^{9i} \mathbf{i}_{8i}^{8i} \times \left(\mathbf{R}_{4i}^{9i} \mathbf{j}_{4i}^{4i} \times \mathbf{r}_{G3i'}^{9i} \right) \right) \frac{\theta_{4i}}{\partial q_j} + \left(\mathbf{R}_{8i}^{9i} \mathbf{i}_{8i}^{8i} \times \left(\mathbf{R}_{8i}^{9i} \mathbf{i}_{8i}^{8i} \times \mathbf{r}_{G3i'}^{9i} \right) \right) \frac{\theta_{8i}}{\partial q_j} + \\
&\quad \left(-\mathbf{j}_{9i}^{9i} \times \mathbf{R}_{8i}^{9i} \mathbf{i}_{8i}^{8i} \right) \times \mathbf{r}_{G3i'}^{9i} + \mathbf{R}_{8i}^{9i} \mathbf{i}_{8i}^{8i} \times \left(\mathbf{j}_{9i}^{9i} \times \mathbf{r}_{G3i'}^{9i} \right) \frac{\theta_{9i}}{\partial q_j}
\end{aligned} \tag{4.101}$$

Acomodando de forma matricial la ec. (4.101) se tiene:

$$\begin{aligned}
\frac{\partial \mathbf{k}_{6i}}{\partial q_j} &= \mathbf{J}_{8i} \frac{\partial \boldsymbol{\theta}_i}{\partial q_j} \\
\mathbf{J}_{8i} &= [\mathbf{J}_{8i,1}, \mathbf{J}_{8i,2}, \mathbf{J}_{8i,3}]
\end{aligned}$$

$$\mathbf{J}_{8i,1} = \mathbf{R}_{8i}^{9i} \mathbf{i}_{8i}^{8i} \times \left(\mathbf{R}_{4i}^{9i} \mathbf{j}_{4i}^{4i} \times \mathbf{r}_{G3i'}^{9i} \right)$$

$$\mathbf{J}_{8i,2} = \mathbf{R}_{8i}^{9i} \mathbf{i}_{8i}^{8i} \times \left(\mathbf{R}_{8i}^{9i} \mathbf{i}_{8i}^{8i} \times \mathbf{r}_{G3i'}^{9i} \right)$$

$$\mathbf{J}_{8i,3} = \left(-\mathbf{j}_{9i}^{9i} \times \mathbf{R}_{8i}^{9i} \mathbf{i}_{8i}^{8i} \right) \times \mathbf{r}_{G3i'}^{9i} + \mathbf{R}_{8i}^{9i} \mathbf{i}_{8i}^{8i} \times \left(\mathbf{j}_{9i}^{9i} \times \mathbf{r}_{G3i'}^{9i} \right)$$

Para obtener el término $\frac{\partial \mathbf{k}_{7i}}{\partial q_j}$, se obtiene la derivada de \mathbf{k}_{7i} respecto al tiempo:

$$\begin{aligned}
\frac{\partial \mathbf{k}_{7i}}{\partial t} &= \left(\left(\mathbf{R}_{4i}^{9i} \dot{\theta}_{4i} \mathbf{j}_{4i}^{4i} + \mathbf{R}_{8i}^{9i} \dot{\theta}_{8i} \mathbf{i}_{8i}^{8i} \right) \times \mathbf{j}_{9i}^{9i} \right) \times \mathbf{r}_{G3i'}^{9i} + \mathbf{j}_{9i}^{9i} \times \left(\left(\mathbf{R}_{4i}^{9i} \dot{\theta}_{4i} \mathbf{j}_{4i}^{4i} + \mathbf{R}_{8i}^{9i} \dot{\theta}_{8i} \mathbf{i}_{8i}^{8i} + \mathbf{j}_{9i}^{9i} \dot{\theta}_{9i} \right) \times \mathbf{r}_{G3i'}^{9i} \right) \\
&= \left(\left(\mathbf{R}_{4i}^{9i} \frac{\partial \theta_{4i}}{\partial t} \mathbf{j}_{4i}^{4i} + \mathbf{R}_{8i}^{9i} \frac{\partial \theta_{8i}}{\partial t} \mathbf{i}_{8i}^{8i} \right) \times \mathbf{j}_{9i}^{9i} \right) \times \mathbf{r}_{G3i'}^{9i} + \\
&\quad \mathbf{j}_{9i}^{9i} \times \left(\left(\mathbf{R}_{4i}^{9i} \frac{\partial \theta_{4i}}{\partial t} \mathbf{j}_{4i}^{4i} + \mathbf{R}_{8i}^{9i} \frac{\partial \theta_{8i}}{\partial t} \mathbf{i}_{8i}^{8i} + \mathbf{j}_{9i}^{9i} \frac{\partial \theta_{9i}}{\partial t} \right) \times \mathbf{r}_{G3i'}^{9i} \right)
\end{aligned}$$

Multiplicando ambos lados de la ecuaci3n anterior por $\frac{\partial t}{\partial q_j}$ con el fin de obtener $\frac{\partial \mathbf{k}_{7i}}{\partial q_j}$ y agrupando:

$$\begin{aligned}
\frac{\partial \mathbf{k}_{7i}}{\partial q_j} &= \left(\left(\mathbf{R}_{4i}^{9i} \frac{\partial \theta_{4i}}{\partial q_j} \mathbf{j}_{4i}^{4i} + \mathbf{R}_{8i}^{9i} \frac{\partial \theta_{8i}}{\partial q_j} \mathbf{i}_{8i}^{8i} \right) \times \mathbf{j}_{9i}^{9i} \right) \times \mathbf{r}_{G3i'}^{9i} + \\
&\quad \mathbf{j}_{9i}^{9i} \times \left(\left(\mathbf{R}_{4i}^{9i} \frac{\partial \theta_{4i}}{\partial q_j} \mathbf{j}_{4i}^{4i} + \mathbf{R}_{8i}^{9i} \frac{\partial \theta_{8i}}{\partial q_j} \mathbf{i}_{8i}^{8i} + \mathbf{j}_{9i}^{9i} \frac{\partial \theta_{9i}}{\partial q_j} \right) \times \mathbf{r}_{G3i'}^{9i} \right) \\
&= \left(\left(\mathbf{R}_{4i}^{9i} \mathbf{j}_{4i}^{4i} \right) \times \mathbf{j}_{9i}^{9i} \right) \times \mathbf{r}_{G3i'}^{9i} \frac{\partial \theta_{4i}}{\partial q_j} + \left(\left(\mathbf{R}_{8i}^{9i} \mathbf{i}_{8i}^{8i} \right) \times \mathbf{j}_{9i}^{9i} \right) \times \mathbf{r}_{G3i'}^{9i} \frac{\partial \theta_{8i}}{\partial q_j} + \\
&\quad \left(\mathbf{j}_{9i}^{9i} \times \left(\mathbf{R}_{4i}^{9i} \mathbf{j}_{4i}^{4i} \right) \times \mathbf{r}_{G3i'}^{9i} \right) \frac{\partial \theta_{4i}}{\partial q_j} + \left(\mathbf{j}_{9i}^{9i} \times \left(\mathbf{R}_{8i}^{9i} \mathbf{i}_{8i}^{8i} \right) \times \mathbf{r}_{G3i'}^{9i} \right) \frac{\partial \theta_{8i}}{\partial q_j} + \\
&\quad \left(\mathbf{j}_{9i}^{9i} \times \left(\mathbf{j}_{9i}^{9i} \times \mathbf{r}_{G3i'}^{9i} \right) \right) \frac{\partial \theta_{9i}}{\partial q_j} \\
\frac{\partial \mathbf{k}_{7i}}{\partial q_j} &= \left(\left(\mathbf{R}_{4i}^{9i} \mathbf{j}_{4i}^{4i} \right) \times \mathbf{j}_{9i}^{9i} \right) \times \mathbf{r}_{G3i'}^{9i} + \mathbf{j}_{9i}^{9i} \times \left(\left(\mathbf{R}_{4i}^{9i} \mathbf{j}_{4i}^{4i} \right) \times \mathbf{r}_{G3i'}^{9i} \right) \frac{\partial \theta_{4i}}{\partial q_j} + \\
&\quad \left(\left(\mathbf{R}_{8i}^{9i} \mathbf{i}_{8i}^{8i} \right) \times \mathbf{j}_{9i}^{9i} \right) \times \mathbf{r}_{G3i'}^{9i} + \mathbf{j}_{9i}^{9i} \times \left(\left(\mathbf{R}_{8i}^{9i} \mathbf{i}_{8i}^{8i} \right) \times \mathbf{r}_{G3i'}^{9i} \right) \frac{\partial \theta_{8i}}{\partial q_j} + \quad (4.102) \\
&\quad \left(\mathbf{j}_{9i}^{9i} \times \left(\mathbf{j}_{9i}^{9i} \times \mathbf{r}_{G3i'}^{9i} \right) \right) \frac{\partial \theta_{9i}}{\partial q_j}
\end{aligned}$$

Acomodando de forma matricial la ec. (4.102) se tiene:

$$\frac{\partial \mathbf{k}_{7i}}{\partial q_j} = \mathbf{J}_{9i} \frac{\partial \theta_i}{\partial q_j}$$

$$\mathbf{J}_{9i} = [\mathbf{J}_{9i,1}, \mathbf{J}_{9i,2}, \mathbf{J}_{9i,3}]$$

$$\mathbf{J}_{9i,1} = \left(\left(\mathbf{R}_{4i}^{9i} \mathbf{j}_{4i}^{4i} \right) \times \mathbf{j}_{9i}^{9i} \right) \times \mathbf{r}_{G3i'}^{9i} + \mathbf{j}_{9i}^{9i} \times \left(\left(\mathbf{R}_{4i}^{9i} \mathbf{j}_{4i}^{4i} \right) \times \mathbf{r}_{G3i'}^{9i} \right)$$

$$\mathbf{J}_{9i,2} = \left(\left(\mathbf{R}_{8i}^{9i} \mathbf{i}_{8i}^{8i} \right) \times \mathbf{j}_{9i}^{9i} \right) \times \mathbf{r}_{G3i'}^{9i} + \mathbf{j}_{9i}^{9i} \times \left(\left(\mathbf{R}_{8i}^{9i} \mathbf{i}_{8i}^{8i} \right) \times \mathbf{r}_{G3i'}^{9i} \right)$$

$$\mathbf{J}_{9i,3} = \mathbf{j}_{9i}^{9i} \times \left(\mathbf{j}_{9i}^{9i} \times \mathbf{r}_{G3i'}^{9i} \right)$$

Para obtener el término $\frac{\partial \mathbf{k}_{8i}}{\partial q_j}$:

$$\frac{\partial \mathbf{k}_{8i}}{\partial q_j} = J_{10i} \frac{\partial \boldsymbol{\theta}_i}{\partial q_j} + \frac{\partial \mathbf{k}'_{8i}}{\partial q_j} \quad (4.103)$$

$$J_{10i} = \left[\frac{\partial \mathbf{k}_{8i}}{\partial \theta_{4i}}, \frac{\partial \mathbf{k}_{8i}}{\partial \theta_{8i}}, \frac{\partial \mathbf{k}_{8i}}{\partial \theta_{9i}} \right]$$

$$\frac{\partial \mathbf{k}_{8i}}{\partial \theta_{4i}} = \frac{\partial}{\partial \theta_{4i}} \left(\frac{1}{V_{16i}} [E_{7i}, E_{8i}, E_{9i}, E_{10i}, E_{11i}, E_{12i}]^T \right)$$

$$\frac{\partial \mathbf{k}_{8i}}{\partial \theta_{8i}} = \frac{\partial}{\partial \theta_{8i}} \left(\frac{1}{V_{16i}} [E_{7i}, E_{8i}, E_{9i}, E_{10i}, E_{11i}, E_{12i}]^T \right)$$

$$\frac{\partial \mathbf{k}_{8i}}{\partial \theta_{9i}} = \frac{\partial}{\partial \theta_{9i}} \left(\frac{1}{V_{16i}} [E_{7i}, E_{8i}, E_{9i}, E_{10i}, E_{11i}, E_{12i}]^T \right)$$

$$\frac{\partial \mathbf{k}'_{8i}}{\partial q_j} = \frac{\partial}{\partial q_j} \left(\frac{1}{V_{16i}} [E_{7i}, E_{8i}, E_{9i}, E_{10i}, E_{11i}, E_{12i}]^T \right)$$

Para obtener el término $\frac{\partial \mathbf{R}_{4i}^{9i} \mathbf{j}_{4i}^{4i}}{\partial q_j}$:

$$\frac{\partial \mathbf{R}_{4i}^{9i} \mathbf{j}_{4i}^{4i}}{\partial q_j} = J_{11i} \frac{\partial \boldsymbol{\theta}_i}{\partial q_j} \quad (4.104)$$

$$J_{11i} = \left[\mathbf{0}, \frac{\partial \mathbf{R}_{4i}^{9i} \mathbf{j}_{4i}^{4i}}{\partial \theta_{8i}}, \frac{\partial \mathbf{R}_{4i}^{9i} \mathbf{j}_{4i}^{4i}}{\partial \theta_{9i}} \right]$$

Para obtener el término $\frac{\partial \mathbf{R}_{8i}^{9i} \mathbf{i}_{6i}^{6i}}{\partial q_j}$:

$$\frac{\partial \mathbf{R}_{8i}^{9i} \mathbf{i}_{6i}^{6i}}{\partial q_j} = J_{12i} \frac{\partial \boldsymbol{\theta}_i}{\partial q_j} \quad (4.105)$$

$$J_{12i} = \left[\mathbf{0}, \mathbf{0}, \frac{\partial \mathbf{R}_{8i}^{9i} \mathbf{i}_{6i}^{6i}}{\partial \theta_{9i}} \right]$$

Para obtener el término $\frac{\partial \mathbf{j}_{9i}^{9i}}{\partial q_j}$, se obtiene la derivada de \mathbf{j}_{9i}^{9i} respecto al tiempo:

$$\begin{aligned} \frac{\partial \mathbf{j}_{9i}^{9i}}{\partial t} &= \left(\mathbf{R}_{4i}^{9i} \dot{\boldsymbol{\theta}}_{4i} \mathbf{j}_{4i}^{4i} + \mathbf{R}_{8i}^{9i} \dot{\boldsymbol{\theta}}_{8i} \mathbf{i}_{8i}^{8i} \right) \times \mathbf{j}_{9i}^{9i} \\ &= \left(\mathbf{R}_{4i}^{9i} \frac{\partial \boldsymbol{\theta}_{4i}}{\partial t} \mathbf{j}_{4i}^{4i} + \mathbf{R}_{8i}^{9i} \frac{\partial \boldsymbol{\theta}_{8i}}{\partial t} \mathbf{i}_{8i}^{8i} \right) \times \mathbf{j}_{9i}^{9i} \end{aligned}$$

Multiplicando ambos lados de la ecuación anterior por $\frac{\partial t}{\partial q_j}$ con el fin de obtener $\frac{\partial \mathbf{j}_{9i}^{9i}}{\partial q_j}$ y agrupando:

$$\begin{aligned}\frac{\partial \mathbf{j}_{9i}^{9i}}{\partial q_j} &= \left(\mathbf{R}_{4i}^{9i} \frac{\partial \theta_{4i}}{\partial q_j} \mathbf{j}_{4i}^{4i} + \mathbf{R}_{8i}^{9i} \frac{\partial \theta_{8i}}{\partial q_j} \mathbf{i}_{8i}^{8i} \right) \times \mathbf{j}_{9i}^{9i} \\ &= \left(\mathbf{R}_{4i}^{9i} \mathbf{j}_{4i}^{4i} \times \mathbf{j}_{9i}^{9i} \right) \frac{\partial \theta_{4i}}{\partial q_j} + \left(\mathbf{R}_{8i}^{9i} \mathbf{i}_{8i}^{8i} \times \mathbf{j}_{9i}^{9i} \right) \frac{\partial \theta_{8i}}{\partial q_j}\end{aligned}\quad (4.106)$$

Acomodando de forma matricial la ec. (4.106) se tiene:

$$\frac{\partial \mathbf{j}_{9i}^{9i}}{\partial q_j} = \mathbf{J}_{13i} \frac{\partial \boldsymbol{\theta}_i}{\partial q_j} \quad (4.107)$$

$$\mathbf{J}_{13i} = [\mathbf{J}_{13i,1}, \mathbf{J}_{13i,2}, \mathbf{J}_{13i,3}]$$

$$\mathbf{J}_{13i,1} = \mathbf{R}_{4i}^{9i} \mathbf{j}_{4i}^{4i} \times \mathbf{j}_{9i}^{9i}$$

$$\mathbf{J}_{13i,2} = \mathbf{R}_{8i}^{9i} \mathbf{i}_{8i}^{8i} \times \mathbf{j}_{9i}^{9i}$$

$$\mathbf{J}_{13i,3} = \mathbf{0}$$

Para obtener $\frac{\partial \mathbf{r}_{G3i}^{0i}}{\partial q_j}$ se parte de la ec. (3.32):

$$\mathbf{v}_{G3i}^0 = \boldsymbol{\omega}_{01i}^0 \times \mathbf{r}_{4i}^0 + \boldsymbol{\omega}_{02i}^0 \times \mathbf{r}_{6i}^0 + \boldsymbol{\omega}_{03i}^0 \times \mathbf{r}_{G3i'}^0$$

$$\frac{\partial \mathbf{r}_{G3i}^0}{\partial t} = \left(\mathbf{R}_{4i}^0 \boldsymbol{\omega}_{1i}^{4i} \right) \times \mathbf{r}_{4i}^0 + \left(\mathbf{R}_{4i}^0 \boldsymbol{\omega}_{1i}^{4i} + \mathbf{R}_{8i}^0 \boldsymbol{\omega}_{2i}^{8i} \right) \times \mathbf{r}_{6i}^0 + \left(\mathbf{R}_{4i}^0 \boldsymbol{\omega}_{1i}^{4i} + \mathbf{R}_{8i}^0 \boldsymbol{\omega}_{2i}^{8i} + \mathbf{R}_{9i}^0 \boldsymbol{\omega}_{3i}^{9i} \right) \times \mathbf{r}_{G3i'}^0$$

$$= \left(\mathbf{R}_{4i}^0 \boldsymbol{\omega}_{1i}^{4i} \right) \times \left(\mathbf{r}_{4i}^0 + \mathbf{r}_{6i}^0 + \mathbf{r}_{G3i'}^0 \right) + \left(\mathbf{R}_{8i}^0 \boldsymbol{\omega}_{2i}^{8i} \right) \times \left(\mathbf{r}_{6i}^0 + \mathbf{r}_{G3i'}^0 \right) + \left(\mathbf{R}_{9i}^0 \boldsymbol{\omega}_{3i}^{9i} \right) \times \mathbf{r}_{G3i'}^0$$

$$\frac{\partial \mathbf{r}_{G3i}^0}{\partial t} = \left(\mathbf{R}_{4i}^0 \dot{\theta}_{4i} \mathbf{j}_{4i}^{4i} \right) \times \left(\mathbf{r}_{4i}^0 + \mathbf{r}_{G3i'}^0 \right) + \left(\mathbf{R}_{8i}^0 \dot{\theta}_{8i} \mathbf{i}_{8i}^{8i} \right) \times \mathbf{r}_{G3i'}^0 + \left(\mathbf{R}_{9i}^0 \dot{\theta}_{9i} \mathbf{j}_{9i}^{9i} \right) \times \mathbf{r}_{G3i'}^0$$

Multiplicando ambos lados de la ecuación anterior por $\frac{\partial t}{\partial q_j}$:

$$\frac{\partial \mathbf{r}_{G3i}^0}{\partial q_j} = \left(\mathbf{R}_{4i}^0 \mathbf{j}_{4i}^{4i} \right) \times \left(\mathbf{r}_{4i}^0 + \mathbf{r}_{G3i'}^0 \right) \frac{\partial \theta_{4i}}{\partial q_j} + \left(\mathbf{R}_{8i}^0 \mathbf{i}_{8i}^{8i} \times \mathbf{r}_{G3i'}^0 \right) \frac{\partial \theta_{8i}}{\partial q_j} + \left(\mathbf{R}_{9i}^0 \mathbf{j}_{9i}^{9i} \times \mathbf{r}_{G3i'}^0 \right) \frac{\partial \theta_{9i}}{\partial q_j} \quad (4.108)$$

Escribiendo matricialmente la ecuación anterior:

$$\frac{\partial \mathbf{r}_{G3i}^0}{\partial q_j} = \mathbf{J}_{14i} \frac{\partial \boldsymbol{\theta}_i}{\partial q_j}$$

Donde:

$$\mathbf{J}_{14i} = [\mathbf{J}_{14i,1}, \mathbf{J}_{14i,2}, \mathbf{J}_{14i,3}]$$

$$\mathbf{J}_{14i,1} = \mathbf{R}_{4i}^0 \mathbf{j}_{4i}^{4i} \times \left(\mathbf{r}_{4i}^0 + \mathbf{r}_{G3i'}^0 \right)$$

$$\mathbf{J}_{14i,2} = \mathbf{R}_{8i}^0 \mathbf{i}_{8i}^{8i} \times \mathbf{r}_{G3i'}^0$$

$$\mathbf{J}_{14i,3} = \mathbf{R}_{9i}^0 \mathbf{j}_{9i}^{9i} \times \mathbf{r}_{G3i'}^0$$

Desarrollando $\frac{\partial L_p}{\partial q_j}$

L_p se define como:

$$L_p = \frac{1}{2} \left(m_p (\mathbf{v}_{Gp}^p)^T \mathbf{v}_{Gp}^p + (\boldsymbol{\omega}_{Op}^p)^T \mathbf{J}_{Gp} \boldsymbol{\omega}_{Op}^p \right) + m_p \mathbf{g}^T \mathbf{r}_{Gp}^0$$

Simplificando:

$$L_p = \frac{1}{2} (\dot{\mathbf{q}}^T \mathbf{N}_4 \dot{\mathbf{q}}) + m_p \mathbf{g}^T \mathbf{r}_{Gp}^0$$

Donde:

$$\mathbf{N}_4 = m_p \mathbf{M}_9^T \mathbf{M}_9 + \mathbf{M}_{10}^T \mathbf{J}_{Gp} \mathbf{M}_{10}$$

$$\mathbf{M}_9 = [\mathbf{R}_0^p, \mathbf{k}_9, \mathbf{k}_{10}, \mathbf{k}_{11}]$$

$$\mathbf{M}_{10} = [\mathbf{0}, \mathbf{0}, \mathbf{0}, \mathbf{k}_{12}, \mathbf{k}_{13}, \mathbf{k}_{14}]$$

$$\mathbf{R}_0^p = \mathbf{R}_{z6} (-\phi) \mathbf{R}_{z4} (-\theta) \mathbf{R}_{z6} (-\psi)$$

$$\mathbf{k}_9 = \mathbf{R}_0^p \mathbf{k}_0^0 \times \mathbf{r}_{Gp}^p$$

$$\mathbf{k}_{10} = \mathbf{R}_{18}^p \mathbf{i}_{18}^{18} \times \mathbf{r}_{Gp}^p$$

$$\mathbf{k}_{11} = \mathbf{k}_{19}^{19} \times \mathbf{r}_{Gp}^p$$

$$\mathbf{k}_{12} = \mathbf{R}_0^p \mathbf{k}_0^0$$

$$\mathbf{k}_{13} = \mathbf{R}_{18}^p \mathbf{i}_{18}^{18}$$

$$\mathbf{k}_{14} = \mathbf{k}_{19}^{19}$$

Derivando respecto a q_j :

$$\begin{aligned} \frac{\partial L_p}{\partial q_j} &= \frac{1}{2} \frac{\partial}{\partial q_j} (\dot{\mathbf{q}}^T \mathbf{N}_4 \dot{\mathbf{q}}) + \frac{\partial}{\partial q_j} (m_p \mathbf{g}^T \mathbf{r}_{Gp}^0) \\ &= \frac{1}{2} \dot{\mathbf{q}}^T \frac{\partial \mathbf{N}_4}{\partial q_j} \dot{\mathbf{q}} + m_p \mathbf{g}^T \frac{\partial \mathbf{r}_{Gp}^0}{\partial q_j} \end{aligned}$$

Finalmente:

$$\frac{\partial L_p}{\partial q_j} = \mathbf{V}'_{4j} \dot{\mathbf{q}} + \mathbf{C}_{4j}$$

Donde:

$$\mathbf{V}'_{4j} = \frac{1}{2} \dot{\mathbf{q}}^T \frac{\partial \mathbf{N}_4}{\partial q_j}$$

$$\mathbf{C}_{4j} = m_p \mathbf{g}^T \frac{\partial \mathbf{r}_{Gp}^0}{\partial q_j}$$

(4.109)

A su vez:

$$\begin{aligned}\frac{\partial N_4}{\partial q_j} &= \frac{\partial}{\partial q_j} (m_p \mathbf{M}_9^T \mathbf{M}_9) + \frac{\partial}{\partial q_j} (\mathbf{M}_{10}^T \mathbf{J}_{Gp} \mathbf{M}_{10}) \\ &= m_p \left(\frac{\partial \mathbf{M}_9^T}{\partial q_j} \mathbf{M}_9 + \mathbf{M}_9^T \frac{\partial \mathbf{M}_9}{\partial q_j} \right) + \left(\frac{\partial \mathbf{M}_{10}^T}{\partial q_j} \mathbf{J}_{Gp} \mathbf{M}_{10} + \mathbf{M}_{10}^T \mathbf{J}_{Gp} \frac{\partial \mathbf{M}_{10}}{\partial q_j} \right)\end{aligned}$$

$$\begin{aligned}\frac{\partial \mathbf{M}_9}{\partial q_j} &= \frac{\partial}{\partial q_j} [\mathbf{R}_0^p, \mathbf{k}_9, \mathbf{k}_{10}, \mathbf{k}_{11}] \\ \frac{\partial \mathbf{M}_{10}}{\partial q_j} &= \frac{\partial}{\partial q_j} [\mathbf{0}, \mathbf{0}, \mathbf{0}, \mathbf{k}_{12}, \mathbf{k}_{13}, \mathbf{k}_{14}]\end{aligned}$$

Ahora se procederá a realizar las derivadas parciales respecto a q_j de los términos que aparecen en las ecuaciones anteriores.

Para obtener el término $\frac{\partial \mathbf{R}_0^p}{\partial q_j}$:

$$\frac{\partial \mathbf{R}_0^p}{\partial q_j} = \frac{\partial \mathbf{R}_0^p}{\partial \psi} \frac{\partial \psi}{\partial q_j} + \frac{\partial \mathbf{R}_0^p}{\partial \theta} \frac{\partial \theta}{\partial q_j} + \frac{\partial \mathbf{R}_0^p}{\partial \phi} \frac{\partial \phi}{\partial q_j} \quad (4.110)$$

Para obtener el término $\frac{\partial \mathbf{k}_9}{\partial q_j}$, se obtiene la derivada de \mathbf{k}_9 respecto al tiempo:

$$\begin{aligned}\frac{\partial \mathbf{k}_9}{\partial t} &= \left((-\mathbf{k}_{12} \dot{\psi} - \mathbf{k}_{13} \dot{\theta} - \mathbf{k}_{14} \dot{\phi}) \times \mathbf{R}_0^p \mathbf{k}_0^0 \right) \times \mathbf{r}_{Gp'}^p + \mathbf{R}_0^p \mathbf{k}_0^0 \times \left((\mathbf{k}_{12} \dot{\psi} + \mathbf{k}_{13} \dot{\theta} + \mathbf{k}_{14} \dot{\phi}) \times \mathbf{r}_{Gp'}^p \right) \\ &= \left(\left(-\mathbf{k}_{12} \frac{\partial \psi}{\partial t} - \mathbf{k}_{13} \frac{\partial \theta}{\partial t} - \mathbf{k}_{14} \frac{\partial \phi}{\partial t} \right) \times \mathbf{R}_0^p \mathbf{k}_0^0 \right) \times \mathbf{r}_{Gp'}^p + \\ &\quad \mathbf{R}_0^p \mathbf{k}_0^0 \times \left(\left(\mathbf{k}_{12} \frac{\partial \psi}{\partial t} + \mathbf{k}_{13} \frac{\partial \theta}{\partial t} + \mathbf{k}_{14} \frac{\partial \phi}{\partial t} \right) \times \mathbf{r}_{Gp'}^p \right)\end{aligned}$$

Multiplicando ambos lados de la ecuación anterior por $\frac{\partial t}{\partial q_j}$ con el fin de obtener $\frac{\partial \mathbf{k}_9}{\partial q_j}$ y agrupando:

$$\begin{aligned}\frac{\partial \mathbf{k}_9}{\partial q_j} &= \left(\left(-\mathbf{k}_{12} \frac{\partial \psi}{\partial q_j} - \mathbf{k}_{13} \frac{\partial \theta}{\partial q_j} - \mathbf{k}_{14} \frac{\partial \phi}{\partial q_j} \right) \times \mathbf{R}_0^p \mathbf{k}_0^0 \right) \times \mathbf{r}_{Gp'}^p + \\ &\quad \mathbf{R}_0^p \mathbf{k}_0^0 \times \left(\left(\mathbf{k}_{12} \frac{\partial \psi}{\partial q_j} + \mathbf{k}_{13} \frac{\partial \theta}{\partial q_j} + \mathbf{k}_{14} \frac{\partial \phi}{\partial q_j} \right) \times \mathbf{r}_{Gp'}^p \right) \\ \frac{\partial \mathbf{k}_9}{\partial q_j} &= \left((-\mathbf{k}_{12} \times \mathbf{R}_0^p \mathbf{k}_0^0) \times \mathbf{r}_{Gp'}^p + \mathbf{R}_0^p \mathbf{k}_0^0 \times (\mathbf{k}_{12} \times \mathbf{r}_{Gp'}^p) \right) \frac{\partial \psi}{\partial q_j} + \\ &\quad \left((-\mathbf{k}_{13} \times \mathbf{R}_0^p \mathbf{k}_0^0) \times \mathbf{r}_{Gp'}^p + \mathbf{R}_0^p \mathbf{k}_0^0 \times (\mathbf{k}_{13} \times \mathbf{r}_{Gp'}^p) \right) \frac{\partial \theta}{\partial q_j} + \\ &\quad \left((-\mathbf{k}_{14} \times \mathbf{R}_0^p \mathbf{k}_0^0) \times \mathbf{r}_{Gp'}^p + \mathbf{R}_0^p \mathbf{k}_0^0 \times (\mathbf{k}_{14} \times \mathbf{r}_{Gp'}^p) \right) \frac{\partial \phi}{\partial q_j}\end{aligned} \quad (4.111)$$

Acomodando de forma matricial la ec. (4.111) se tiene:

$$\frac{\partial \mathbf{k}_0}{\partial q_j} = \mathbf{J}_{15} \frac{\partial \Psi}{\partial q_j}$$

$$\mathbf{J}_{15} = [\mathbf{J}_{15,1}, \mathbf{J}_{15,2}, \mathbf{J}_{15,3}]$$

$$\frac{\partial \Psi}{\partial q_j} = \left[\frac{\partial \psi}{\partial q_j}, \frac{\partial \theta}{\partial q_j}, \frac{\partial \phi}{\partial q_j} \right]^T$$

$$\mathbf{J}_{15,1} = (-\mathbf{k}_{12} \times \mathbf{R}_0^p \mathbf{k}_0^0) \times \mathbf{r}_{Gp'}^p + \mathbf{R}_0^p \mathbf{k}_0^0 \times (\mathbf{k}_{12} \times \mathbf{r}_{Gp'}^p)$$

$$\mathbf{J}_{15,2} = (-\mathbf{k}_{13} \times \mathbf{R}_0^p \mathbf{k}_0^0) \times \mathbf{r}_{Gp'}^p + \mathbf{R}_0^p \mathbf{k}_0^0 \times (\mathbf{k}_{13} \times \mathbf{r}_{Gp'}^p)$$

$$\mathbf{J}_{15,3} = (-\mathbf{k}_{14} \times \mathbf{R}_0^p \mathbf{k}_0^0) \times \mathbf{r}_{Gp'}^p + \mathbf{R}_0^p \mathbf{k}_0^0 \times (\mathbf{k}_{14} \times \mathbf{r}_{Gp'}^p)$$

Para el término $\frac{\partial \mathbf{k}_{10}}{\partial q_j}$, se obtiene la derivada de \mathbf{k}_{10} respecto al tiempo:

$$\begin{aligned} \frac{\partial \mathbf{k}_{10}}{\partial t} &= ((-\mathbf{k}_{13} \dot{\theta} - \mathbf{k}_{14} \dot{\phi}) \times \mathbf{R}_{18}^p \mathbf{i}_{18}^{18}) \times \mathbf{r}_{Gp'}^p + \mathbf{R}_{18}^p (\dot{\psi} \mathbf{k}_0^0 \times \mathbf{i}_{18}^{18}) \times \mathbf{r}_{Gp'}^p + \\ &\quad \mathbf{R}_{18}^p \mathbf{i}_{18}^{18} \times ((\mathbf{k}_{12} \dot{\psi} + \mathbf{k}_{13} \dot{\theta} + \mathbf{k}_{14} \dot{\phi}) \times \mathbf{r}_{Gp'}^p) \\ &= \left(\left(-\mathbf{k}_{13} \frac{\partial \theta}{\partial t} - \mathbf{k}_{14} \frac{\partial \phi}{\partial t} \right) \times \mathbf{R}_{18}^p \mathbf{i}_{18}^{18} \right) \times \mathbf{r}_{Gp'}^p + \mathbf{R}_{18}^p \left(\frac{\partial \psi}{\partial t} \mathbf{k}_0^0 \times \mathbf{i}_{18}^{18} \right) \times \mathbf{r}_{Gp'}^p + \\ &\quad \mathbf{R}_{18}^p \mathbf{i}_{18}^{18} \times \left(\left(\mathbf{k}_{12} \frac{\partial \psi}{\partial t} + \mathbf{k}_{13} \frac{\partial \theta}{\partial t} + \mathbf{k}_{14} \frac{\partial \phi}{\partial t} \right) \times \mathbf{r}_{Gp'}^p \right) \end{aligned}$$

Multiplicando ambos lados de la ecuación anterior por $\frac{\partial t}{\partial q_j}$ con el fin de obtener $\frac{\partial \mathbf{k}_{10}}{\partial q_j}$ y

agrupando:

$$\begin{aligned} \frac{\partial \mathbf{k}_{10}}{\partial q_j} &= \left(\left(-\mathbf{k}_{13} \frac{\partial \theta}{\partial q_j} - \mathbf{k}_{14} \frac{\partial \phi}{\partial q_j} \right) \times \mathbf{R}_{18}^p \mathbf{i}_{18}^{18} \right) \times \mathbf{r}_{Gp'}^p + \mathbf{R}_{18}^p \left(\frac{\partial \psi}{\partial q_j} \mathbf{k}_0^0 \times \mathbf{i}_{18}^{18} \right) \times \mathbf{r}_{Gp'}^p + \\ &\quad \mathbf{R}_{18}^p \mathbf{i}_{18}^{18} \times \left(\left(\mathbf{k}_{12} \frac{\partial \psi}{\partial q_j} + \mathbf{k}_{13} \frac{\partial \theta}{\partial q_j} + \mathbf{k}_{14} \frac{\partial \phi}{\partial q_j} \right) \times \mathbf{r}_{Gp'}^p \right) \\ &= \left(\mathbf{R}_{18}^p (\mathbf{k}_0^0 \times \mathbf{i}_{18}^{18}) \times \mathbf{r}_{Gp'}^p + \mathbf{R}_{18}^p \mathbf{i}_{18}^{18} \times (\mathbf{k}_{12} \times \mathbf{r}_{Gp'}^p) \right) \frac{\partial \psi}{\partial q_j} + \\ &\quad \left((-\mathbf{k}_{13} \times \mathbf{R}_{18}^p \mathbf{i}_{18}^{18}) \times \mathbf{r}_{Gp'}^p + \mathbf{R}_{18}^p \mathbf{i}_{18}^{18} \times (\mathbf{k}_{13} \times \mathbf{r}_{Gp'}^p) \right) \frac{\partial \theta}{\partial q_j} + \\ &\quad \left((-\mathbf{k}_{14} \times \mathbf{R}_{18}^p \mathbf{i}_{18}^{18}) \times \mathbf{r}_{Gp'}^p + \mathbf{R}_{18}^p \mathbf{i}_{18}^{18} \times (\mathbf{k}_{14} \times \mathbf{r}_{Gp'}^p) \right) \frac{\partial \phi}{\partial q_j} \end{aligned} \tag{4.112}$$

Acomodando de forma matricial la ec. (4.112) se tiene:

$$\frac{\partial \mathbf{k}_{10}}{\partial q_j} = \mathbf{J}_{16} \frac{\partial \Psi}{\partial q_j}$$

$$\mathbf{J}_{16} = [\mathbf{J}_{16,1}, \mathbf{J}_{16,2}, \mathbf{J}_{16,3}]$$

$$\mathbf{J}_{16,1} = \mathbf{R}_{18}^p (\mathbf{k}_0^0 \times \mathbf{i}_{18}^{18}) \times \mathbf{r}_{Gp'}^p + \mathbf{R}_{18}^p \mathbf{i}_{18}^{18} \times (\mathbf{k}_{12} \times \mathbf{r}_{Gp'}^p)$$

$$\mathbf{J}_{16,2} = (-\mathbf{k}_{13} \times \mathbf{R}_{18}^p \mathbf{i}_{18}^{18}) \times \mathbf{r}_{Gp'}^p + \mathbf{R}_{18}^p \mathbf{i}_{18}^{18} \times (\mathbf{k}_{13} \times \mathbf{r}_{Gp'}^p)$$

$$\mathbf{J}_{16,3} = (-\mathbf{k}_{14} \times \mathbf{R}_{18}^p \mathbf{i}_{18}^{18}) \times \mathbf{r}_{Gp'}^p + \mathbf{R}_{18}^p \mathbf{i}_{18}^{18} \times (\mathbf{k}_{14} \times \mathbf{r}_{Gp'}^p)$$

Para el término $\frac{\partial \mathbf{k}_{11}}{\partial q_j}$, se obtiene la derivada de \mathbf{k}_{11} respecto al tiempo:

$$\frac{\partial \mathbf{k}_{11}}{\partial t} = \left(\left(\mathbf{R}_0^{19} \dot{\psi} \mathbf{k}_0^0 + \mathbf{R}_{18}^{19} \dot{\theta} \mathbf{i}_{18}^{18} \right) \times \mathbf{k}_{19}^{19} \right) \times \mathbf{r}_{Gp'}^p + \mathbf{k}_{19}^{19} \times \left(\left(\mathbf{k}_{12} \dot{\psi} + \mathbf{k}_{13} \dot{\theta} + \mathbf{k}_{14} \dot{\phi} \right) \times \mathbf{r}_{Gp'}^p \right)$$

$$= \left(\left(\mathbf{R}_0^{19} \frac{\partial \Psi}{\partial t} \mathbf{k}_0^0 + \mathbf{R}_{18}^{19} \frac{\partial \theta}{\partial t} \mathbf{i}_{18}^{18} \right) \times \mathbf{k}_{19}^{19} \right) \times \mathbf{r}_{Gp'}^p +$$

$$\mathbf{k}_{19}^{19} \times \left(\left(\mathbf{k}_{12} \frac{\partial \Psi}{\partial t} + \mathbf{k}_{13} \frac{\partial \theta}{\partial t} + \mathbf{k}_{14} \frac{\partial \phi}{\partial t} \right) \times \mathbf{r}_{Gp'}^p \right)$$

Multiplicando ambos lados de la ecuación anterior por $\frac{\partial t}{\partial q_j}$ con el fin de obtener $\frac{\partial \mathbf{k}_{11}}{\partial q_j}$ y agrupando:

$$\frac{\partial \mathbf{k}_{11}}{\partial q_j} = \left(\left(\mathbf{R}_0^{19} \frac{\partial \Psi}{\partial q_j} \mathbf{k}_0^0 + \mathbf{R}_{18}^{19} \frac{\partial \theta}{\partial q_j} \mathbf{i}_{18}^{18} \right) \times \mathbf{k}_{19}^{19} \right) \times \mathbf{r}_{Gp'}^p +$$

$$\mathbf{k}_{19}^{19} \times \left(\left(\mathbf{k}_{12} \frac{\partial \Psi}{\partial q_j} + \mathbf{k}_{13} \frac{\partial \theta}{\partial q_j} + \mathbf{k}_{14} \frac{\partial \phi}{\partial q_j} \right) \times \mathbf{r}_{Gp'}^p \right)$$

$$\frac{\partial \mathbf{k}_{11}}{\partial q_j} = \left(\left(\mathbf{R}_0^{19} \mathbf{k}_0^0 \times \mathbf{k}_{19}^{19} \right) \times \mathbf{r}_{Gp'}^p + \mathbf{k}_{19}^{19} \times \left(\mathbf{k}_{12} \times \mathbf{r}_{Gp'}^p \right) \right) \frac{\partial \Psi}{\partial q_j} +$$

$$\left(\left(\mathbf{R}_{18}^{19} \mathbf{i}_{18}^{18} \times \mathbf{k}_{19}^{19} \right) \times \mathbf{r}_{Gp'}^p + \mathbf{k}_{19}^{19} \times \left(\mathbf{k}_{13} \times \mathbf{r}_{Gp'}^p \right) \right) \frac{\partial \theta}{\partial q_j} +$$

$$\left(\mathbf{k}_{19}^{19} \times \left(\mathbf{k}_{14} \times \mathbf{r}_{Gp'}^p \right) \right) \frac{\partial \phi}{\partial q_j} \quad (4.113)$$

Acomodando de forma matricial la ec. (4.113) se tiene:

$$\frac{\partial \mathbf{k}_{11}}{\partial q_j} = \mathbf{J}_{17} \frac{\partial \Psi}{\partial q_j}$$

$$\mathbf{J}_{17} = [\mathbf{J}_{17,1}, \mathbf{J}_{17,2}, \mathbf{J}_{17,3}]$$

$$\mathbf{J}_{17,1} = (\mathbf{R}_0^{19} \mathbf{k}_0^0 \times \mathbf{k}_{19}^{19}) \times \mathbf{r}_{G_p'}^p + \mathbf{k}_{19}^{19} \times (\mathbf{k}_{12} \times \mathbf{r}_{G_p'}^p)$$

$$\mathbf{J}_{17,2} = (\mathbf{R}_{18}^{19} \mathbf{i}_{18}^{18} \times \mathbf{k}_{19}^{19}) \times \mathbf{r}_{G_p'}^p + \mathbf{k}_{19}^{19} \times (\mathbf{k}_{13} \times \mathbf{r}_{G_p'}^p)$$

$$\mathbf{J}_{17,3} = \mathbf{k}_{19}^{19} \times (\mathbf{k}_{14} \times \mathbf{r}_{G_p'}^p)$$

Para obtener el término $\frac{\partial \mathbf{k}_{12}}{\partial q_j}$, se obtiene la derivada de \mathbf{k}_{12} respecto al tiempo:

$$\begin{aligned} \frac{\partial \mathbf{k}_{12}}{\partial t} &= (-\mathbf{k}_{12} \dot{\psi} - \mathbf{k}_{13} \dot{\theta} - \mathbf{k}_{14} \dot{\phi}) \times \mathbf{R}_0^p \mathbf{k}_0^0 \\ &= \left(-\mathbf{k}_{12} \frac{\partial \psi}{\partial t} - \mathbf{k}_{13} \frac{\partial \theta}{\partial t} - \mathbf{k}_{14} \frac{\partial \phi}{\partial t} \right) \times \mathbf{R}_0^p \mathbf{k}_0^0 \end{aligned}$$

Multiplicando ambos lados de la ecuación anterior por $\frac{\partial t}{\partial q_j}$ con el fin de obtener $\frac{\partial \mathbf{k}_{12}}{\partial q_j}$ y

agrupando:

$$\begin{aligned} \frac{\partial \mathbf{k}_{12}}{\partial q_j} &= \left(-\mathbf{k}_{12} \frac{\partial \psi}{\partial q_j} - \mathbf{k}_{13} \frac{\partial \theta}{\partial q_j} - \mathbf{k}_{14} \frac{\partial \phi}{\partial q_j} \right) \times \mathbf{R}_0^p \mathbf{k}_0^0 \\ \frac{\partial \mathbf{k}_{12}}{\partial q_j} &= (-\mathbf{k}_{12} \times \mathbf{R}_0^p \mathbf{k}_0^0) \frac{\partial \psi}{\partial q_j} + (-\mathbf{k}_{13} \times \mathbf{R}_0^p \mathbf{k}_0^0) \frac{\partial \theta}{\partial q_j} + (-\mathbf{k}_{14} \times \mathbf{R}_0^p \mathbf{k}_0^0) \frac{\partial \phi}{\partial q_j} \end{aligned} \quad (4.114)$$

Acomodando de forma matricial la ec. (4.114) se tiene:

$$\begin{aligned} \frac{\partial \mathbf{k}_{12}}{\partial q_j} &= \mathbf{J}_{18} \frac{\partial \Psi}{\partial q_j} \\ \mathbf{J}_{18} &= [\mathbf{J}_{18,1}, \mathbf{J}_{18,2}, \mathbf{J}_{18,3}] \end{aligned}$$

$$\mathbf{J}_{18,1} = -\mathbf{k}_{12} \times \mathbf{R}_0^p \mathbf{k}_0^0$$

$$\mathbf{J}_{18,2} = -\mathbf{k}_{13} \times \mathbf{R}_0^p \mathbf{k}_0^0$$

$$\mathbf{J}_{18,3} = -\mathbf{k}_{14} \times \mathbf{R}_0^p \mathbf{k}_0^0$$

Para obtener el término $\frac{\partial \mathbf{k}_{13}}{\partial q_j}$, se obtiene la derivada de \mathbf{k}_{13} respecto al tiempo:

$$\begin{aligned} \frac{\partial \mathbf{k}_{13}}{\partial t} &= (-\mathbf{k}_{13} \dot{\theta} - \mathbf{k}_{14} \dot{\phi}) \times \mathbf{R}_{18}^p \mathbf{i}_{18}^{18} + \mathbf{R}_{18}^p (\dot{\psi} \mathbf{k}_0^0 \times \mathbf{i}_{18}^{18}) \\ &= \left(-\mathbf{k}_{13} \frac{\partial \theta}{\partial t} - \mathbf{k}_{14} \frac{\partial \phi}{\partial t} \right) \times \mathbf{R}_{18}^p \mathbf{i}_{18}^{18} + \mathbf{R}_{18}^p \left(\frac{\partial \psi}{\partial t} \mathbf{k}_0^0 \times \mathbf{i}_{18}^{18} \right) \end{aligned}$$

Multiplicando ambos lados de la ecuación anterior por $\frac{\partial t}{\partial q_j}$ con el fin de obtener $\frac{\partial \mathbf{k}_{13}}{\partial q_j}$ y

agrupando:

$$\begin{aligned}\frac{\partial \mathbf{k}_{13}}{\partial q_j} &= \left(-\mathbf{k}_{13} \frac{\partial \theta}{\partial q_j} - \mathbf{k}_{14} \frac{\partial \phi}{\partial q_j} \right) \times \mathbf{R}_{18}^p \mathbf{i}_{18}^{18} + \mathbf{R}_{18}^p \left(\frac{\partial \psi}{\partial q_j} \mathbf{k}_0^0 \times \mathbf{i}_{18}^{18} \right) \\ &= \left(\mathbf{R}_{18}^p \left(\mathbf{k}_0^0 \times \mathbf{i}_{18}^{18} \right) \right) \frac{\partial \psi}{\partial q_j} + \left(-\mathbf{k}_{13} \times \mathbf{R}_{18}^p \mathbf{i}_{18}^{18} \right) \frac{\partial \theta}{\partial q_j} + \left(-\mathbf{k}_{14} \times \mathbf{R}_{18}^p \mathbf{i}_{18}^{18} \right) \frac{\partial \phi}{\partial q_j}\end{aligned}\quad (4.115)$$

Acomodando de forma matricial la ec. (4.115) se tiene:

$$\begin{aligned}\frac{\partial \mathbf{k}_{13}}{\partial q_j} &= \mathbf{J}_{19} \frac{\partial \psi}{\partial q_j} \\ \mathbf{J}_{19} &= [\mathbf{J}_{19,1}, \mathbf{J}_{19,2}, \mathbf{J}_{19,3}]\end{aligned}$$

$$\mathbf{J}_{19,1} = \mathbf{R}_{18}^p \left(\mathbf{k}_0^0 \times \mathbf{i}_{18}^{18} \right)$$

$$\mathbf{J}_{19,2} = -\mathbf{k}_{13} \times \mathbf{R}_{18}^p \mathbf{i}_{18}^{18}$$

$$\mathbf{J}_{19,3} = -\mathbf{k}_{14} \times \mathbf{R}_{18}^p \mathbf{i}_{18}^{18}$$

Para obtener el término $\frac{\partial \mathbf{k}_{14}}{\partial q_j}$, se obtiene la derivada de \mathbf{k}_{14} respecto al tiempo:

$$\begin{aligned}\frac{\partial \mathbf{k}_{14}}{\partial t} &= \left(\mathbf{R}_0^{19} \dot{\psi} \mathbf{k}_0^0 + \mathbf{R}_{18}^{19} \dot{\theta} \mathbf{i}_{18}^{18} \right) \times \mathbf{k}_{19}^{19} \\ &= \left(\mathbf{R}_0^{19} \frac{\partial \psi}{\partial t} \mathbf{k}_0^0 + \mathbf{R}_{18}^{19} \frac{\partial \theta}{\partial t} \mathbf{i}_{18}^{18} \right) \times \mathbf{k}_{19}^{19}\end{aligned}$$

Multiplicando ambos lados de la ecuación anterior por $\frac{\partial t}{\partial q_j}$ con el fin de obtener $\frac{\partial \mathbf{k}_{14}}{\partial q_j}$ y agrupando:

$$\begin{aligned}\frac{\partial \mathbf{k}_{14}}{\partial q_j} &= \left(\mathbf{R}_0^{19} \frac{\partial \psi}{\partial q_j} \mathbf{k}_0^0 + \mathbf{R}_{18}^{19} \frac{\partial \theta}{\partial q_j} \mathbf{i}_{18}^{18} \right) \times \mathbf{k}_{19}^{19} \\ &= \left(\mathbf{R}_0^{19} \mathbf{k}_0^0 \times \mathbf{k}_{19}^{19} \right) \frac{\partial \psi}{\partial q_j} + \left(\mathbf{R}_{18}^{19} \mathbf{i}_{18}^{18} \times \mathbf{k}_{19}^{19} \right) \frac{\partial \theta}{\partial q_j}\end{aligned}\quad (4.116)$$

Acomodando de forma matricial la ec. (4.116) se tiene:

$$\begin{aligned}\frac{\partial \mathbf{k}_{14}}{\partial q_j} &= \mathbf{J}_{20} \frac{\partial \psi}{\partial q_j} \\ \mathbf{J}_{20} &= [\mathbf{J}_{20,1}, \mathbf{J}_{20,2}, \mathbf{J}_{20,3}]\end{aligned}$$

$$\mathbf{J}_{20,1} = \mathbf{R}_0^{19} \mathbf{k}_0^0 \times \mathbf{k}_{19}^{19}$$

$$\mathbf{J}_{20,2} = \mathbf{R}_{18}^{19} \mathbf{i}_{18}^{18} \times \mathbf{k}_{19}^{19}$$

$$\mathbf{J}_{20,3} = \mathbf{0}$$

Para obtener $\frac{\partial \mathbf{r}_{Gp}^0}{\partial q_j}$ se parte de la ec. (3.48):

$$\begin{aligned}\mathbf{v}_{Gp}^0 &= \mathbf{v}_p^0 + \boldsymbol{\omega}_{Op}^0 \times \mathbf{r}_{Gp}^0 \\ \frac{\partial \mathbf{r}_{Gp}^0}{\partial t} &= \mathbf{v}_p^0 + (\boldsymbol{\omega}_\psi^0 + \mathbf{R}_{18}^0 \boldsymbol{\omega}_\theta^{18} + \mathbf{R}_{19}^0 \boldsymbol{\omega}_\phi^{19}) \times \mathbf{r}_{Gp}^0 \\ &= \mathbf{v}_p^0 + (\dot{\psi} \mathbf{k}_0^0 + \mathbf{R}_{18}^0 \dot{\theta} \mathbf{i}_{18}^{18} + \mathbf{R}_{19}^0 \dot{\phi} \mathbf{k}_{19}^{19}) \times \mathbf{r}_{Gp}^0 \\ \frac{\partial \mathbf{r}_{Gp}^0}{\partial t} &= \frac{\partial \mathbf{r}_p^0}{\partial t} + \left(\frac{\partial \psi}{\partial t} \mathbf{k}_0^0 + \mathbf{R}_{18}^0 \frac{\partial \theta}{\partial t} \mathbf{i}_{18}^{18} + \mathbf{R}_{19}^0 \frac{\partial \phi}{\partial t} \mathbf{k}_{19}^{19} \right) \times \mathbf{r}_{Gp}^0\end{aligned}$$

Multiplicando ambos lados de la ecuación anterior por $\frac{\partial t}{\partial q_j}$:

$$\begin{aligned}\frac{\partial \mathbf{r}_{Gp}^0}{\partial q_j} &= \frac{\partial \mathbf{r}_p^0}{\partial q_j} + \left(\frac{\partial \psi}{\partial q_j} \mathbf{k}_0^0 + \mathbf{R}_{18}^0 \frac{\partial \theta}{\partial q_j} \mathbf{i}_{18}^{18} + \mathbf{R}_{19}^0 \frac{\partial \phi}{\partial q_j} \mathbf{k}_{19}^{19} \right) \times \mathbf{r}_{Gp}^0 \\ &= \frac{\partial \mathbf{r}_p^0}{\partial q_j} + (\mathbf{k}_0^0 \times \mathbf{r}_{Gp}^0) \frac{\partial \psi}{\partial q_j} + (\mathbf{R}_{18}^0 \mathbf{i}_{18}^{18} \times \mathbf{r}_{Gp}^0) \frac{\partial \theta}{\partial q_j} + (\mathbf{R}_{19}^0 \mathbf{k}_{19}^{19} \times \mathbf{r}_{Gp}^0) \frac{\partial \phi}{\partial q_j}\end{aligned}$$

Escribiendo matricialmente la ecuación anterior:

$$\frac{\partial \mathbf{r}_{Gp}^0}{\partial q_j} = \mathbf{J}_{21} \frac{\partial \mathbf{q}}{\partial q_j}$$

Donde:

$$\begin{aligned}\mathbf{J}_{21} &= [\mathbf{I}_{3 \times 3}, \mathbf{J}_{21,1}, \mathbf{J}_{21,2}, \mathbf{J}_{21,3}] \\ \frac{\partial \mathbf{q}}{\partial q_j} &= \left[\frac{\partial \mathbf{r}_p^0}{\partial q_j}, \frac{\partial \psi}{\partial q_j}, \frac{\partial \theta}{\partial q_j}, \frac{\partial \phi}{\partial q_j} \right]^T\end{aligned}$$

$$\begin{aligned}\mathbf{J}_{21,1} &= \mathbf{k}_0^0 \times \mathbf{r}_{Gp}^0 \\ \mathbf{J}_{21,2} &= \mathbf{R}_{18}^0 \mathbf{i}_{18}^{18} \times \mathbf{r}_{Gp}^0 \\ \mathbf{J}_{21,3} &= \mathbf{R}_{19}^0 \mathbf{k}_{19}^{19} \times \mathbf{r}_{Gp}^0\end{aligned}$$

Desarrollando $\frac{\partial L_c}{\partial q_j}$

L_c se define como:

$$L_c = \frac{1}{2} \left(m_c (\mathbf{v}_{Gc}^p)^T \mathbf{v}_{Gc}^p + (\boldsymbol{\omega}_{Oc}^p)^T \mathbf{J}_{Gc} \boldsymbol{\omega}_{Oc}^p \right) + m_c \mathbf{g}^T \mathbf{r}_{Gc}^0$$

Simplificando:

$$L_c = \frac{1}{2} (\dot{\mathbf{q}}^T \mathbf{N}_s \dot{\mathbf{q}}) + m_c \mathbf{g}^T \mathbf{r}_{Gc}^0$$

Donde:

$$\mathbf{N}_5 = m_c \mathbf{M}_{11}^T \mathbf{M}_{11} + \mathbf{M}_{10}^T \mathbf{J}_{Gc} \mathbf{M}_{10}$$

$$\mathbf{M}_{10} = [\mathbf{0}, \mathbf{0}, \mathbf{0}, \mathbf{k}_{12}, \mathbf{k}_{13}, \mathbf{k}_{14}]$$

$$\mathbf{M}_{11} = [\mathbf{R}_0^p, \mathbf{k}_{15}, \mathbf{k}_{16}, \mathbf{k}_{17}]$$

$$\mathbf{R}_0^p = \mathbf{R}_{z6}(-\phi) \mathbf{R}_{z4}(-\theta) \mathbf{R}_{z6}(-\psi)$$

$$\mathbf{k}_{12} = \mathbf{R}_0^p \mathbf{k}_0^0$$

$$\mathbf{k}_{13} = \mathbf{R}_{18}^p \mathbf{i}_{18}^{18}$$

$$\mathbf{k}_{14} = \mathbf{k}_{19}^{19}$$

$$\mathbf{k}_{15} = \mathbf{R}_0^p \mathbf{k}_0^0 \times \mathbf{r}_{Gc}^p$$

$$\mathbf{k}_{16} = \mathbf{R}_{18}^p \mathbf{i}_{18}^{18} \times \mathbf{r}_{Gc}^p$$

$$\mathbf{k}_{17} = \mathbf{k}_{19}^{19} \times \mathbf{r}_{Gc}^p$$

Derivando respecto a q_j :

$$\begin{aligned} \frac{\partial L_c}{\partial q_j} &= \frac{1}{2} \frac{\partial}{\partial q_j} (\dot{\mathbf{q}}^T \mathbf{N}_5 \dot{\mathbf{q}}) + \frac{\partial}{\partial q_j} (m_c \mathbf{g}^T \mathbf{r}_{Gc}^0) \\ &= \frac{1}{2} \dot{\mathbf{q}}^T \frac{\partial \mathbf{N}_5}{\partial q_j} \dot{\mathbf{q}} + m_c \mathbf{g}^T \frac{\partial \mathbf{r}_{Gc}^0}{\partial q_j} \end{aligned}$$

Finalmente:

$$\frac{\partial L_c}{\partial q_j} = V'_{5j} \dot{\mathbf{q}} + C_{5j} \quad (4.117)$$

Donde:

$$\begin{aligned} V'_{5j} &= \frac{1}{2} \dot{\mathbf{q}}^T \frac{\partial \mathbf{N}_5}{\partial q_j} \\ C_{5j} &= m_c \mathbf{g}^T \frac{\partial \mathbf{r}_{Gc}^0}{\partial q_j} \end{aligned} \quad (4.118)$$

A su vez:

$$\begin{aligned} \frac{\partial \mathbf{N}_5}{\partial q_j} &= \frac{\partial}{\partial q_j} (m_c \mathbf{M}_{11}^T \mathbf{M}_{11}) + \frac{\partial}{\partial q_j} (\mathbf{M}_{10}^T \mathbf{J}_{Gc} \mathbf{M}_{10}) \\ &= m_c \left(\frac{\partial \mathbf{M}_{11}^T}{\partial q_j} \mathbf{M}_{11} + \mathbf{M}_{11}^T \frac{\partial \mathbf{M}_{11}}{\partial q_j} \right) + \left(\frac{\partial \mathbf{M}_{10}^T}{\partial q_j} \mathbf{J}_{Gc} \mathbf{M}_{10} + \mathbf{M}_{10}^T \mathbf{J}_{Gc} \frac{\partial \mathbf{M}_{10}}{\partial q_j} \right) \end{aligned}$$

$$\frac{\partial \mathbf{M}_{11}}{\partial q_j} = \frac{\partial}{\partial q_j} [\mathbf{R}_0^p, \mathbf{k}_{15}, \mathbf{k}_{16}, \mathbf{k}_{17}]$$

$$\frac{\partial \mathbf{M}_{10}}{\partial q_j} = \frac{\partial}{\partial q_j} [\mathbf{0}, \mathbf{0}, \mathbf{0}, \mathbf{k}_{12}, \mathbf{k}_{13}, \mathbf{k}_{14}]$$

Ahora se procederá a realizar las derivadas parciales respecto a q_j de los términos que aparecen en las ecuaciones anteriores.

Para obtener el término $\frac{\partial \mathbf{k}_{15}}{\partial q_j}$, se obtiene la derivada de \mathbf{k}_{15} respecto al tiempo:

$$\begin{aligned} \frac{\partial \mathbf{k}_{15}}{\partial t} &= \left((-\mathbf{k}_{12}\dot{\psi} - \mathbf{k}_{13}\dot{\theta} - \mathbf{k}_{14}\dot{\phi}) \times \mathbf{R}_0^p \mathbf{k}_0^0 \right) \times \mathbf{r}_{Gc'}^p + \mathbf{R}_0^p \mathbf{k}_0^0 \times \left((\mathbf{k}_{12}\dot{\psi} + \mathbf{k}_{13}\dot{\theta} + \mathbf{k}_{14}\dot{\phi}) \times \mathbf{r}_{Gc'}^p \right) \\ &= \left(\left(-\mathbf{k}_{12} \frac{\partial \psi}{\partial t} - \mathbf{k}_{13} \frac{\partial \theta}{\partial t} - \mathbf{k}_{14} \frac{\partial \phi}{\partial t} \right) \times \mathbf{R}_0^p \mathbf{k}_0^0 \right) \times \mathbf{r}_{Gc'}^p + \mathbf{R}_0^p \mathbf{k}_0^0 \times \left(\left(\mathbf{k}_{12} \frac{\partial \psi}{\partial t} + \mathbf{k}_{13} \frac{\partial \theta}{\partial t} + \mathbf{k}_{14} \frac{\partial \phi}{\partial t} \right) \times \mathbf{r}_{Gc'}^p \right) \end{aligned}$$

Multiplicando ambos lados de la ecuación anterior por $\frac{\partial t}{\partial q_j}$ con el fin de obtener $\frac{\partial \mathbf{k}_{15}}{\partial q_j}$ y

agrupando:

$$\begin{aligned} \frac{\partial \mathbf{k}_{15}}{\partial q_j} &= \left(\left(-\mathbf{k}_{12} \frac{\partial \psi}{\partial q_j} - \mathbf{k}_{13} \frac{\partial \theta}{\partial q_j} - \mathbf{k}_{14} \frac{\partial \phi}{\partial q_j} \right) \times \mathbf{R}_0^p \mathbf{k}_0^0 \right) \times \mathbf{r}_{Gc'}^p + \\ &\quad \mathbf{R}_0^p \mathbf{k}_0^0 \times \left(\left(\mathbf{k}_{12} \frac{\partial \psi}{\partial q_j} + \mathbf{k}_{13} \frac{\partial \theta}{\partial q_j} + \mathbf{k}_{14} \frac{\partial \phi}{\partial q_j} \right) \times \mathbf{r}_{Gc'}^p \right) \\ \frac{\partial \mathbf{k}_{15}}{\partial q_j} &= \left((-\mathbf{k}_{12} \times \mathbf{R}_0^p \mathbf{k}_0^0) \times \mathbf{r}_{Gc'}^p + \mathbf{R}_0^p \mathbf{k}_0^0 \times (\mathbf{k}_{12} \times \mathbf{r}_{Gc'}^p) \right) \frac{\partial \psi}{\partial q_j} \\ &\quad \left((-\mathbf{k}_{13} \times \mathbf{R}_0^p \mathbf{k}_0^0) \times \mathbf{r}_{Gc'}^p + \mathbf{R}_0^p \mathbf{k}_0^0 \times (\mathbf{k}_{13} \times \mathbf{r}_{Gc'}^p) \right) \frac{\partial \theta}{\partial q_j} \\ &\quad \left((-\mathbf{k}_{14} \times \mathbf{R}_0^p \mathbf{k}_0^0) \times \mathbf{r}_{Gc'}^p + \mathbf{R}_0^p \mathbf{k}_0^0 \times (\mathbf{k}_{14} \times \mathbf{r}_{Gc'}^p) \right) \frac{\partial \phi}{\partial q_j} \end{aligned} \quad (4.119)$$

Acomodando de forma matricial la ec. (4.119) se tiene:

$$\begin{aligned} \frac{\partial \mathbf{k}_{15i}}{\partial q_j} &= \mathbf{J}_{22} \frac{\partial \Psi}{\partial q_j} \\ \mathbf{J}_{22} &= [\mathbf{J}_{22,1}, \mathbf{J}_{22,2}, \mathbf{J}_{22,3}] \\ \mathbf{J}_{22,1} &= (-\mathbf{k}_{12} \times \mathbf{R}_0^p \mathbf{k}_0^0) \times \mathbf{r}_{Gc'}^p + \mathbf{R}_0^p \mathbf{k}_0^0 \times (\mathbf{k}_{12} \times \mathbf{r}_{Gc'}^p) \\ \mathbf{J}_{22,2} &= (-\mathbf{k}_{13} \times \mathbf{R}_0^p \mathbf{k}_0^0) \times \mathbf{r}_{Gc'}^p + \mathbf{R}_0^p \mathbf{k}_0^0 \times (\mathbf{k}_{13} \times \mathbf{r}_{Gc'}^p) \\ \mathbf{J}_{22,3} &= (-\mathbf{k}_{14} \times \mathbf{R}_0^p \mathbf{k}_0^0) \times \mathbf{r}_{Gc'}^p + \mathbf{R}_0^p \mathbf{k}_0^0 \times (\mathbf{k}_{14} \times \mathbf{r}_{Gc'}^p) \end{aligned}$$

Para el término $\frac{\partial \mathbf{k}_{16}}{\partial q_j}$, se obtiene la derivada de \mathbf{k}_{16} respecto al tiempo:

$$\begin{aligned} \frac{\partial \mathbf{k}_{16}}{\partial t} &= \left((-\mathbf{k}_{13} \dot{\theta} - \mathbf{k}_{14} \dot{\phi}) \times \mathbf{R}_{18}^p \mathbf{i}_{18}^{18} \right) \times \mathbf{r}_{Gc'}^p + \mathbf{R}_{18}^p (\dot{\psi} \mathbf{k}_0^0 \times \mathbf{i}_{18}^{18}) \times \mathbf{r}_{Gc'}^p + \mathbf{R}_{18}^p \mathbf{i}_{18}^{18} \times \left((\mathbf{k}_{12} \dot{\psi} + \mathbf{k}_{13} \dot{\theta} + \mathbf{k}_{14} \dot{\phi}) \times \mathbf{r}_{Gc'}^p \right) \\ &= \left(\left(-\mathbf{k}_{13} \frac{\partial \theta}{\partial t} - \mathbf{k}_{14} \frac{\partial \phi}{\partial t} \right) \times \mathbf{R}_{18}^p \mathbf{i}_{18}^{18} \right) \times \mathbf{r}_{Gc'}^p + \mathbf{R}_{18}^p \left(\frac{\partial \psi}{\partial t} \mathbf{k}_0^0 \times \mathbf{i}_{18}^{18} \right) \times \mathbf{r}_{Gc'}^p + \\ &\quad \mathbf{R}_{18}^p \mathbf{i}_{18}^{18} \times \left(\left(\mathbf{k}_{12} \frac{\partial \psi}{\partial t} + \mathbf{k}_{13} \frac{\partial \theta}{\partial t} + \mathbf{k}_{14} \frac{\partial \phi}{\partial t} \right) \times \mathbf{r}_{Gc'}^p \right) \end{aligned}$$

Multiplicando ambos lados de la ecuación anterior por $\frac{\partial t}{\partial q_j}$ con el fin de obtener $\frac{\partial \mathbf{k}_{16}}{\partial q_j}$ y agrupando:

$$\begin{aligned} \frac{\partial \mathbf{k}_{16}}{\partial q_j} &= \left(\left(-\mathbf{k}_{13} \frac{\partial \theta}{\partial q_j} - \mathbf{k}_{14} \frac{\partial \phi}{\partial q_j} \right) \times \mathbf{R}_{18}^p \mathbf{i}_{18}^{18} \right) \times \mathbf{r}_{Gc'}^p + \mathbf{R}_{18}^p \left(\frac{\partial \psi}{\partial q_j} \mathbf{k}_0^0 \times \mathbf{i}_{18}^{18} \right) \times \mathbf{r}_{Gc'}^p + \\ &\quad \mathbf{R}_{18}^p \mathbf{i}_{18}^{18} \times \left(\left(\mathbf{k}_{12} \frac{\partial \psi}{\partial q_j} + \mathbf{k}_{13} \frac{\partial \theta}{\partial q_j} + \mathbf{k}_{14} \frac{\partial \phi}{\partial q_j} \right) \times \mathbf{r}_{Gc'}^p \right) \\ &= \left(\mathbf{R}_{18}^p \left(\mathbf{k}_0^0 \times \mathbf{i}_{18}^{18} \right) \times \mathbf{r}_{Gc'}^p + \mathbf{R}_{18}^p \mathbf{i}_{18}^{18} \times \left(\mathbf{k}_{12} \times \mathbf{r}_{Gc'}^p \right) \right) \frac{\partial \psi}{\partial q_j} + \\ &\quad \left(\left(-\mathbf{k}_{13} \times \mathbf{R}_{18}^p \mathbf{i}_{18}^{18} \right) \times \mathbf{r}_{Gc'}^p + \mathbf{R}_{18}^p \mathbf{i}_{18}^{18} \times \left(\mathbf{k}_{13} \times \mathbf{r}_{Gc'}^p \right) \right) \frac{\partial \theta}{\partial q_j} + \\ &\quad \left(\left(-\mathbf{k}_{14} \times \mathbf{R}_{18}^p \mathbf{i}_{18}^{18} \right) \times \mathbf{r}_{Gc'}^p + \mathbf{R}_{18}^p \mathbf{i}_{18}^{18} \times \left(\mathbf{k}_{14} \times \mathbf{r}_{Gc'}^p \right) \right) \frac{\partial \phi}{\partial q_j} \end{aligned} \quad (4.120)$$

Acomodando de forma matricial la ec. (4.120) se tiene:

$$\begin{aligned} \frac{\partial \mathbf{k}_{16}}{\partial q_j} &= \mathbf{J}_{23} \frac{\partial \psi}{\partial q_j} \\ \mathbf{J}_{23} &= [\mathbf{J}_{23,1}, \mathbf{J}_{23,2}, \mathbf{J}_{23,3}] \\ \mathbf{J}_{23,1} &= \mathbf{R}_{18}^p \left(\mathbf{k}_0^0 \times \mathbf{i}_{18}^{18} \right) \times \mathbf{r}_{Gc'}^p + \mathbf{R}_{18}^p \mathbf{i}_{18}^{18} \times \left(\mathbf{k}_{12} \times \mathbf{r}_{Gc'}^p \right) \\ \mathbf{J}_{23,2} &= \left(-\mathbf{k}_{13} \times \mathbf{R}_{18}^p \mathbf{i}_{18}^{18} \right) \times \mathbf{r}_{Gc'}^p + \mathbf{R}_{18}^p \mathbf{i}_{18}^{18} \times \left(\mathbf{k}_{13} \times \mathbf{r}_{Gc'}^p \right) \\ \mathbf{J}_{23,3} &= \left(-\mathbf{k}_{14} \times \mathbf{R}_{18}^p \mathbf{i}_{18}^{18} \right) \times \mathbf{r}_{Gc'}^p + \mathbf{R}_{18}^p \mathbf{i}_{18}^{18} \times \left(\mathbf{k}_{14} \times \mathbf{r}_{Gc'}^p \right) \end{aligned}$$

Para el término $\frac{\partial \mathbf{k}_{17}}{\partial q_j}$, se obtiene la derivada de \mathbf{k}_{17} respecto al tiempo:

$$\begin{aligned} \frac{\partial \mathbf{k}_{17}}{\partial t} &= \left(\left(\mathbf{R}_{19}^p \dot{\psi} \mathbf{k}_0^0 + \mathbf{R}_{18}^p \dot{\theta} \mathbf{i}_{18}^{18} \right) \times \mathbf{k}_{19}^{19} \right) \times \mathbf{r}_{Gc'}^p + \mathbf{k}_{19}^{19} \times \left((\mathbf{k}_{12} \dot{\psi} + \mathbf{k}_{13} \dot{\theta} + \mathbf{k}_{14} \dot{\phi}) \times \mathbf{r}_{Gc'}^p \right) \\ &= \left(\left(\mathbf{R}_{19}^p \frac{\partial \psi}{\partial t} \mathbf{k}_0^0 + \mathbf{R}_{18}^p \frac{\partial \theta}{\partial t} \mathbf{i}_{18}^{18} \right) \times \mathbf{k}_{19}^{19} \right) \times \mathbf{r}_{Gc'}^p + \mathbf{k}_{19}^{19} \times \left(\left(\mathbf{k}_{12} \frac{\partial \psi}{\partial t} + \mathbf{k}_{13} \frac{\partial \theta}{\partial t} + \mathbf{k}_{14} \frac{\partial \phi}{\partial t} \right) \times \mathbf{r}_{Gc'}^p \right) \end{aligned}$$

Multiplicando ambos lados de la ecuación anterior por $\frac{\partial t}{\partial q_j}$ con el fin de obtener $\frac{\partial \mathbf{k}_{17}}{\partial q_j}$ y agrupando:

$$\begin{aligned} \frac{\partial \mathbf{k}_{17}}{\partial q_j} = & \left(\left(\mathbf{R}_0^{19} \frac{\partial \psi}{\partial q_j} \mathbf{k}_0^0 + \mathbf{R}_{18}^{19} \frac{\partial \theta}{\partial q_j} \mathbf{i}_{18}^{18} \right) \times \mathbf{k}_{19}^{19} \right) \times \mathbf{r}_{Gc'}^p + \\ & \mathbf{k}_{19}^{19} \times \left(\left(\mathbf{k}_{12} \frac{\partial \psi}{\partial q_j} + \mathbf{k}_{13} \frac{\partial \theta}{\partial q_j} + \mathbf{k}_{14} \frac{\partial \phi}{\partial q_j} \right) \times \mathbf{r}_{Gc'}^p \right) \\ \frac{\partial \mathbf{k}_{17}}{\partial q_j} = & \left(\left(\mathbf{R}_0^{19} \mathbf{k}_0^0 \times \mathbf{k}_{19}^{19} \right) \times \mathbf{r}_{Gc'}^p + \mathbf{k}_{19}^{19} \times \left(\mathbf{k}_{12} \times \mathbf{r}_{Gc'}^p \right) \right) \frac{\partial \psi}{\partial q_j} + \\ & \left(\left(\mathbf{R}_{18}^{19} \mathbf{i}_{18}^{18} \times \mathbf{k}_{19}^{19} \right) \times \mathbf{r}_{Gc'}^p + \mathbf{k}_{19}^{19} \times \left(\mathbf{k}_{13} \times \mathbf{r}_{Gc'}^p \right) \right) \frac{\partial \theta}{\partial q_j} + \\ & \left(\mathbf{k}_{19}^{19} \times \left(\mathbf{k}_{14} \times \mathbf{r}_{Gc'}^p \right) \right) \frac{\partial \phi}{\partial q_j} \end{aligned} \quad (4.121)$$

Acomodando de forma matricial la ec. (4.121) se tiene:

$$\begin{aligned} \frac{\partial \mathbf{k}_{17}}{\partial q_j} &= \mathbf{J}_{24} \frac{\partial \Psi}{\partial q_j} \\ \mathbf{J}_{24} &= [\mathbf{J}_{24,1}, \mathbf{J}_{24,2}, \mathbf{J}_{24,3}] \\ \mathbf{J}_{24,1} &= \left(\mathbf{R}_0^{19} \mathbf{k}_0^0 \times \mathbf{k}_{19}^{19} \right) \times \mathbf{r}_{Gc'}^p + \mathbf{k}_{19}^{19} \times \left(\mathbf{k}_{12} \times \mathbf{r}_{Gc'}^p \right) \\ \mathbf{J}_{24,2} &= \left(\mathbf{R}_{18}^{19} \mathbf{i}_{18}^{18} \times \mathbf{k}_{19}^{19} \right) \times \mathbf{r}_{Gc'}^p + \mathbf{k}_{19}^{19} \times \left(\mathbf{k}_{13} \times \mathbf{r}_{Gc'}^p \right) \\ \mathbf{J}_{24,3} &= \mathbf{k}_{19}^{19} \times \left(\mathbf{k}_{14} \times \mathbf{r}_{Gc'}^p \right) \end{aligned}$$

Para obtener $\frac{\partial \mathbf{r}_{Gc}^0}{\partial q_j}$ se parte de la ec. (3.56):

$$\begin{aligned} \mathbf{v}_{Gc}^0 &= \mathbf{v}_p^0 + \boldsymbol{\omega}_{Oc}^0 \times \mathbf{r}_{Gc'}^0 \\ \frac{\partial \mathbf{r}_{Gc}^0}{\partial t} &= \mathbf{v}_p^0 + \left(\boldsymbol{\omega}_\psi^0 + \mathbf{R}_{18}^0 \boldsymbol{\omega}_\theta^{18} + \mathbf{R}_{19}^0 \boldsymbol{\omega}_\phi^{19} \right) \times \mathbf{r}_{Gc'}^0 \\ &= \mathbf{v}_p^0 + \left(\dot{\psi} \mathbf{k}_0^0 + \mathbf{R}_{18}^0 \dot{\theta} \mathbf{i}_{18}^{18} + \mathbf{R}_{19}^0 \dot{\phi} \mathbf{k}_{19}^{19} \right) \times \mathbf{r}_{Gc'}^0 \\ \frac{\partial \mathbf{r}_{Gc}^0}{\partial t} &= \frac{\partial \mathbf{r}_p^0}{\partial t} + \left(\frac{\partial \psi}{\partial t} \mathbf{k}_0^0 + \mathbf{R}_{18}^0 \frac{\partial \theta}{\partial t} \mathbf{i}_{18}^{18} + \mathbf{R}_{19}^0 \frac{\partial \phi}{\partial t} \mathbf{k}_{19}^{19} \right) \times \mathbf{r}_{Gc'}^0 \end{aligned}$$

Multiplicando ambos lados de la ecuación anterior por $\frac{\partial t}{\partial q_j}$:

$$\begin{aligned}\frac{\partial \mathbf{r}_{Gc}^0}{\partial q_j} &= \frac{\partial \mathbf{r}_p^0}{\partial q_j} + \left(\frac{\partial \psi}{\partial q_j} \mathbf{k}_0^0 + \mathbf{R}_{18}^0 \frac{\partial \theta}{\partial q_j} \mathbf{i}_{18}^{18} + \mathbf{R}_{19}^0 \frac{\partial \phi}{\partial q_j} \mathbf{k}_{19}^{19} \right) \times \mathbf{r}_{Gc}^0 \\ &= \frac{\partial \mathbf{r}_p^0}{\partial q_j} + (\mathbf{k}_0^0 \times \mathbf{r}_{Gc}^0) \frac{\partial \psi}{\partial q_j} + (\mathbf{R}_{18}^0 \mathbf{i}_{18}^{18} \times \mathbf{r}_{Gc}^0) \frac{\partial \theta}{\partial q_j} + (\mathbf{R}_{19}^0 \mathbf{k}_{19}^{19} \times \mathbf{r}_{Gc}^0) \frac{\partial \phi}{\partial q_j}\end{aligned}$$

Escribiendo matricialmente la ecuación anterior:

$$\frac{\partial \mathbf{r}_{Gc}^0}{\partial q_j} = \mathbf{J}_{25} \frac{\partial \mathbf{q}}{\partial q_j}$$

Donde:

$$\mathbf{J}_{25} = [\mathbf{I}_{3 \times 3}, \mathbf{J}_{25,1}, \mathbf{J}_{25,2}, \mathbf{J}_{25,3}]$$

$$\mathbf{J}_{25,1} = \mathbf{k}_0^0 \times \mathbf{r}_{Gc}^0$$

$$\mathbf{J}_{25,2} = \mathbf{R}_{18}^0 \mathbf{i}_{18}^{18} \times \mathbf{r}_{Gc}^0$$

$$\mathbf{J}_{25,3} = \mathbf{R}_{19}^0 \mathbf{k}_{19}^{19} \times \mathbf{r}_{Gc}^0$$

4.3.3. Fuerzas Generalizadas

La formulación de la ecuación de Lagrange considera el uso de fuerzas generalizadas contemplando las fuerzas aplicadas externamente, fuerzas y torques de actuadores, de modo que es necesario desarrollar estas expresiones para que sean compatibles con el lagrangiano, y además consistentes con las restricciones mecánicas. Las fuerzas generalizadas se obtienen a partir de la expresión de trabajo virtual.

Primero consideremos el caso en el cual los actuadores ejercen una fuerza o torque en las juntas y fuerzas y momentos externos son aplicados al efector final. Definamos $\boldsymbol{\tau} = [\tau_1, \tau_2, \tau_3, \tau_4, \tau_5, \tau_6]^T$ como un vector que representa el torque generado en las juntas y $\mathbf{F}_e = [\mathbf{f}_e, \mathbf{n}_e]^T$, el vector de seis coordenadas de las fuerzas y momentos resultantes en el efector final. Por lo tanto el trabajo virtual producido por estas fuerzas y momentos es:

$$\delta W = \sum_{i=1}^6 \mathbf{F}_i^T \delta \mathbf{R}_i + \mathbf{M}_i^T \delta \mathbf{Q}_i$$

Aplicado al robot, donde i, j representan el número de cadena y cuerpo respectivamente:

$$\begin{aligned}\delta W &= \sum_{i=1}^6 \sum_{j=1}^3 (\mathbf{f}_{ij}^T \delta \mathbf{r}_{ij} + \mathbf{m}_{ij}^T \delta \mathbf{Q}_{ij}) + \mathbf{f}_{ext}^T \delta \mathbf{r}_{ext} + \mathbf{n}_{ext}^T \delta \mathbf{Q}_{ext} \\ &= \sum_{i=1}^6 \boldsymbol{\tau}_i^{0T} \delta \mathbf{Q}_i^0 + \mathbf{f}_{ext}^{0T} \delta \mathbf{r}_{ext}^0 + \mathbf{n}_{ext}^{0T} \delta \mathbf{Q}_{ext}^0\end{aligned}\tag{4.122}$$

Obteniendo los términos $\boldsymbol{\tau}_i^0$:

$$\begin{aligned}\boldsymbol{\tau}_i^0 &= \mathbf{R}_{4i}^0 (\boldsymbol{\tau}_i \mathbf{J}_{4i}^{4i}) \\ \mathbf{R}_{4i}^0 &= \mathbf{R}_{26} (\delta_{1i} + \delta_{3i}) \mathbf{R}_{25} (\theta_{4i})\end{aligned}\tag{4.123}$$

Las velocidades angulares se relacionan con los desplazamientos virtuales, esto es:

$$\delta Q = \frac{\partial \omega}{\partial \theta} \delta \theta$$

Se plantean los desplazamientos virtuales que están relacionados con las fuerzas externas:

$$\delta Q_i^0 = \frac{\partial \omega_{01i}^0}{\partial \theta_{4i}} \delta \theta_{4i} \quad (4.124)$$

Donde:

$$\begin{aligned} \omega_{01i}^0 &= \mathbf{R}_{4i}^0 \omega_{1i}^{4i} \\ \omega_{1i}^{4i} &= \dot{\theta}_{4i} \mathbf{j}_{4i}^{4i} \end{aligned} \quad (4.125)$$

Sustituyendo la ec. (4.125) en (4.124):

$$\begin{aligned} \delta Q_i^0 &= \frac{\partial \mathbf{R}_{4i}^0 \mathbf{j}_{4i}^{4i} \dot{\theta}_{4i}}{\partial \theta_{4i}} \delta \theta_{4i} \\ &= \mathbf{R}_{4i}^0 \mathbf{j}_{4i}^{4i} \delta \theta_{4i} \end{aligned} \quad (4.126)$$

De la ec. (4.122) tenemos:

$$\sum_{i=1}^6 \boldsymbol{\tau}_i^{0T} \delta Q_i^0 = \boldsymbol{\tau}_1^{0T} \delta Q_1^0 + \boldsymbol{\tau}_2^{0T} \delta Q_2^0 + \boldsymbol{\tau}_3^{0T} \delta Q_3^0 + \boldsymbol{\tau}_4^{0T} \delta Q_4^0 + \boldsymbol{\tau}_5^{0T} \delta Q_5^0 + \boldsymbol{\tau}_6^{0T} \delta Q_6^0 \quad (4.127)$$

Sustituyendo los términos de las ec. (4.123) y (4.126) en la ec. (4.127) se tiene:

$$\begin{aligned} \sum_{i=1}^6 \boldsymbol{\tau}_i^{0T} \delta Q_i^0 &= \sum_{i=1}^6 (\mathbf{R}_{4i}^0 \boldsymbol{\tau}_i \mathbf{j}_{4i}^{4i})^T (\mathbf{R}_{4i}^0 \mathbf{j}_{4i}^{4i} \delta \theta_{4i}) \\ &= \sum_{i=1}^6 \boldsymbol{\tau}_i (\mathbf{j}_{4i}^{4iT} \mathbf{R}_{4i}^{0T}) (\mathbf{R}_{4i}^0 \mathbf{j}_{4i}^{4i}) \delta \theta_{4i} \\ &= \sum_{i=1}^6 \boldsymbol{\tau}_i \mathbf{j}_{4i}^{4iT} \mathbf{j}_{4i}^{4i} \delta \theta_{4i} \\ &= \sum_{i=1}^6 \boldsymbol{\tau}_i \delta \theta_{4i} \\ \sum_{i=1}^6 \boldsymbol{\tau}_i^{0T} \delta Q_i^0 &= \tau_1 \delta \theta_{41} + \tau_2 \delta \theta_{42} + \tau_3 \delta \theta_{43} + \tau_4 \delta \theta_{44} + \tau_5 \delta \theta_{45} + \tau_6 \delta \theta_{46} \end{aligned} \quad (4.128)$$

Escribiendo matricialmente la ec. (4.128):

$$\sum_{i=1}^6 \boldsymbol{\tau}_i^{0T} \delta Q_i^0 = \boldsymbol{\tau}^T \delta \Theta \quad (4.129)$$

Donde:

$$\begin{aligned} \boldsymbol{\tau}^T &= [\tau_1, \tau_2, \tau_3, \tau_4, \tau_5, \tau_6] \\ \delta \Theta &= [\delta \theta_{41}, \delta \theta_{42}, \delta \theta_{43}, \delta \theta_{44}, \delta \theta_{45}, \delta \theta_{46}]^T \end{aligned}$$

Ahora, con el fin de poner la ec. (4.129) en función de $\delta \mathbf{q}$, se tiene de la ec. (2.93):

$$\mathbf{J}_q \dot{\mathbf{q}} = \mathbf{J}_\theta \dot{\Theta}$$

Dividiendo ambos lados de la ec. anterior por δt y despejando $\delta \Theta$:

$$\delta \Theta = \mathbf{J}_\theta^{-1} \mathbf{J}_q \delta \mathbf{q} \quad (4.130)$$

Finalmente, sustituyendo la ec. (4.130) en (4.129):

$$\sum_{i=1}^6 \boldsymbol{\tau}_i^{0T} \delta Q_i^0 = \boldsymbol{\tau}^T \mathbf{J}_\theta^{-1} \mathbf{J}_q \delta \mathbf{q} \quad (4.131)$$

Para obtener el término $\delta \mathbf{r}_{ext}^0$, se tiene:

$$\mathbf{r}_{ext}^0 = \mathbf{r}_p^0 + \mathbf{R}_p^0 \mathbf{r}_e^p$$

$$\mathbf{r}_p^0 = [x_p, y_p, z_p]^T$$

$$\mathbf{r}_e^p = [x_e, y_e, z_e]^T$$

Obteniendo ahora el cambio virtual en el vector \mathbf{r}_{ext}^0 :

$$\begin{aligned} \delta \mathbf{r}_e^0 &= \delta \mathbf{r}_p^0 + \delta \mathbf{R}_p^0 \mathbf{r}_e^p \\ &= \delta \mathbf{r}_p^0 + \left(\frac{\partial \mathbf{R}_p^0}{\partial \psi} \delta \psi + \frac{\partial \mathbf{R}_p^0}{\partial \theta} \delta \theta + \frac{\partial \mathbf{R}_p^0}{\partial \phi} \delta \phi \right) \mathbf{r}_e^p \\ &= \delta \mathbf{r}_p^0 + \frac{\partial \mathbf{R}_p^0}{\partial \psi} \mathbf{r}_e^p \delta \psi + \frac{\partial \mathbf{R}_p^0}{\partial \theta} \mathbf{r}_e^p \delta \theta + \frac{\partial \mathbf{R}_p^0}{\partial \phi} \mathbf{r}_e^p \delta \phi \end{aligned}$$

Escribiendo matricialmente la ecuación anterior:

$$\delta \mathbf{r}_{ext}^0 = \mathbf{J}_{26} \delta \mathbf{q} \quad (4.132)$$

Donde:

$$\mathbf{J}_{26} = [\mathbf{I}_{3 \times 3}, \mathbf{J}_{26,1}, \mathbf{J}_{26,2}, \mathbf{J}_{26,3}]$$

$$\delta \mathbf{q} = [\delta \mathbf{r}_p^0, \delta \psi, \delta \theta, \delta \phi]^T$$

$$\mathbf{J}_{26,1} = \frac{\partial \mathbf{R}_p^0}{\partial \psi} \mathbf{r}_e^p$$

$$\mathbf{J}_{26,2} = \frac{\partial \mathbf{R}_p^0}{\partial \theta} \mathbf{r}_e^p$$

$$\mathbf{J}_{26,3} = \frac{\partial \mathbf{R}_p^0}{\partial \phi} \mathbf{r}_e^p$$

Para obtener el término $\delta \mathbf{Q}_{ext}^0$:

$$\delta \mathbf{Q}_{ext}^0 = \frac{\partial \omega_{Op}^0}{\partial \dot{\psi}} \delta \psi + \frac{\partial \omega_{Op}^0}{\partial \dot{\theta}} \delta \theta + \frac{\partial \omega_{Op}^0}{\partial \dot{\phi}} \delta \phi \quad (4.133)$$

Donde:

$$\omega_{Op}^0 = \omega_{\psi}^0 + \mathbf{R}_{18}^0 \omega_{\theta}^{18} + \mathbf{R}_{19}^0 \omega_{\phi}^{19}$$

$$\omega_{\psi}^0 = \dot{\psi} \mathbf{k}_0^0$$

$$\omega_{\theta}^{18} = \dot{\theta} \mathbf{i}_{18}^{18}$$

$$\omega_{\phi}^{19} = \dot{\phi} \mathbf{k}_{19}^{19}$$

$$\mathbf{R}_{18i}^0 = \mathbf{R}_{z_6}(\psi)$$

$$\mathbf{R}_{19i}^0 = \mathbf{R}_{z_6}(\psi) \mathbf{R}_{z_4}(\theta)$$

Sustituyendo los términos anteriores en la ec. (4.133):

$$\begin{aligned}\delta Q_{ext}^0 &= \frac{\partial}{\partial \dot{\psi}} \left(\mathbf{k}_0^0 \dot{\psi} + \mathbf{R}_{18}^0 \dot{\theta} + \mathbf{R}_{19}^0 \dot{\phi} \right) \delta \psi + \frac{\partial}{\partial \dot{\theta}} \left(\mathbf{k}_0^0 \dot{\psi} + \mathbf{R}_{18}^0 \dot{\theta} + \mathbf{R}_{19}^0 \dot{\phi} \right) \delta \theta + \\ &\quad \frac{\partial}{\partial \dot{\phi}} \left(\mathbf{k}_0^0 \dot{\psi} + \mathbf{R}_{18}^0 \dot{\theta} + \mathbf{R}_{19}^0 \dot{\phi} \right) \delta \phi \\ &= \mathbf{k}_0^0 \delta \psi + \mathbf{R}_{18}^0 \delta \theta + \mathbf{R}_{19}^0 \delta \phi\end{aligned}$$

Escribiendo matricialmente la ecuación anterior:

$$\delta Q_{ext}^0 = \mathbf{J}_{27} \delta \mathbf{q} \quad (4.134)$$

Donde:

$$\begin{aligned}\mathbf{J}_{27} &= [\mathbf{0}, \mathbf{0}, \mathbf{0}, \mathbf{J}_{27,1}, \mathbf{J}_{27,2}, \mathbf{J}_{27,3}] \\ \delta \mathbf{q} &= [\delta \mathbf{r}_p^0, \delta \psi, \delta \theta, \delta \phi]^T\end{aligned}$$

$$\mathbf{J}_{27,1} = \mathbf{k}_0^0$$

$$\mathbf{J}_{27,2} = \mathbf{R}_{18}^0 \mathbf{i}_{18}^{18}$$

$$\mathbf{J}_{27,3} = \mathbf{R}_{19}^0 \mathbf{k}_{19}^{19}$$

Por último, sustituyendo las ecs. (4.131), (4.132) y (4.134) en (4.122):

$$\begin{aligned}\delta W &= \sum_{i=1}^6 \boldsymbol{\tau}_i^{0T} \delta Q_i^0 + \mathbf{f}_{ext}^T \delta \mathbf{r}_{ext} + \mathbf{n}_{ext}^T \delta Q_{ext} \\ &= \boldsymbol{\tau}^T \mathbf{J}_\theta^{-1} \mathbf{J}_q \delta \mathbf{q} + \mathbf{f}_{ext}^T \mathbf{J}_{26} \delta \mathbf{q} + \mathbf{n}_{ext}^T \mathbf{J}_{27} \delta \mathbf{q} \\ &= (\boldsymbol{\tau}^T \mathbf{J}_\theta^{-1} \mathbf{J}_q + \mathbf{f}_{ext}^T \mathbf{J}_{26} + \mathbf{n}_{ext}^T \mathbf{J}_{27}) \delta \mathbf{q} \\ &= \mathbf{Q}^T \delta \mathbf{q}\end{aligned} \quad (4.135)$$

Las fuerzas generalizadas obtenidas son:

$$\mathbf{Q}^T = \boldsymbol{\tau}^T \mathbf{J}_\theta^{-1} \mathbf{J}_q + \mathbf{f}_{ext}^T \mathbf{J}_{26} + \mathbf{n}_{ext}^T \mathbf{J}_{27} \quad (4.136)$$

4.3.4. Sustitución de los términos en la Ecuación de Lagrange

Por último, se tiene la ec. (4.4):

$$\frac{d}{dt} \left(\frac{\partial L}{\partial \dot{q}_j} \right) - \frac{\partial L}{\partial q_j} = Q_j$$

Donde:

$$\begin{aligned}\frac{d}{dt} \left(\frac{\partial L}{\partial \dot{q}_j} \right) &= \frac{d}{dt} \left(\sum_{i=1}^6 \left(\frac{\partial L_{1i}}{\partial \dot{q}_j} + \frac{\partial L_{2i}}{\partial \dot{q}_j} + \frac{\partial L_{3i}}{\partial \dot{q}_j} \right) + \frac{\partial L_p}{\partial \dot{q}_j} + \frac{\partial L_c}{\partial \dot{q}_j} \right) \\ &= \sum_{i=1}^6 (D_{1ij} \ddot{\mathbf{q}} + V_{1ij} \dot{\mathbf{q}} + D_{2ij} \ddot{\mathbf{q}} + V_{2ij} \dot{\mathbf{q}} + D_{3ij} \ddot{\mathbf{q}} + V_{3ij} \dot{\mathbf{q}}) + D_{4j} \ddot{\mathbf{q}} + V_{4j} \dot{\mathbf{q}} + D_{5j} \ddot{\mathbf{q}} + V_{5j} \dot{\mathbf{q}} \\ &= \left[\sum_{i=1}^6 (D_{1ij} + D_{2ij} + D_{3ij}) + D_{4j} + D_{5j} \right] \ddot{\mathbf{q}} + \left[\sum_{i=1}^6 (V_{1ij} + V_{2ij} + V_{3ij}) + V_{4j} + V_{5j} \right] \dot{\mathbf{q}}\end{aligned}$$

$$\begin{aligned}
\frac{\partial L}{\partial q_j} &= \sum_{i=1}^6 \frac{\partial}{\partial q_j} (L_{1i} + L_{2i} + L_{3i}) + \frac{\partial L_p}{\partial q_j} + \frac{\partial L_c}{\partial q_j} \\
&= \sum_{i=1}^6 (V'_{1ij} \dot{q} + C_{1ij} + V'_{2ij} \dot{q} + C_{2ij} + V'_{3ij} \dot{q} + C_{3ij}) + V'_{4j} \dot{q} + C_{4j} + V'_{5j} \dot{q} + C_{5j} \\
&= \left[\sum_{i=1}^6 (V'_{1ij} + V'_{2ij} + V'_{3ij}) + V'_{4j} + V'_{5j} \right] \dot{q} + \left[\sum_{i=1}^6 (C_{1ij} + C_{2ij} + C_{3ij}) + C_{4j} + C_{5j} \right]
\end{aligned}$$

$$Q^T = \tau^T J_\theta^{-1} J_q + f_{ext}^T J_{26} + n_{ext}^T J_{27}$$

$$Q = (J_\theta^{-1} J_q)^T \tau + J_{26}^T f_{ext} + J_{27}^T n_{ext}$$

Sustituyendo en la ec. (4.4):

$$\begin{aligned}
&\left[\sum_{i=1}^6 (D_{1ij} + D_{2ij} + D_{3ij}) + D_{4j} + D_{5j} \right] \ddot{q} + \left[\sum_{i=1}^6 (V_{1ij} + V_{2ij} + V_{3ij}) + V_{4j} + V_{5j} \right] \dot{q} - \\
&\left[\sum_{i=1}^6 (V'_{1ij} + V'_{2ij} + V'_{3ij}) + V'_{4j} + V'_{5j} \right] \dot{q} - \left[\sum_{i=1}^6 (C_{1ij} + C_{2ij} + C_{3ij}) + C_{4j} + C_{5j} \right] = Q_j \\
&\qquad\qquad\qquad \left[\sum_{i=1}^6 (D_{1ij} + D_{2ij} + D_{3ij}) + D_{4j} + D_{5j} \right] \ddot{q} + \\
&\left[\sum_{i=1}^6 (V_{1ij} + V_{2ij} + V_{3ij}) + V_{4j} + V_{5j} - \sum_{i=1}^6 (V'_{1ij} + V'_{2ij} + V'_{3ij}) - V'_{4j} - V'_{5j} \right] \dot{q} + \\
&\left[\sum_{i=1}^6 (-C_{1ij} - C_{2ij} - C_{3ij}) - C_{4j} - C_{5j} \right] = Q_j
\end{aligned}$$

Finalmente:

$$D_j \ddot{q} + V_j \dot{q} + C_j = Q_j \quad (4.137)$$

Donde:

$$\begin{aligned}
D_j &= \left[\sum_{i=1}^6 (D_{1ij} + D_{2ij} + D_{3ij}) + D_{4j} + D_{5j} \right] \\
V_j &= \left[\sum_{i=1}^6 (V_{1ij} + V_{2ij} + V_{3ij}) + V_{4j} + V_{5j} - \sum_{i=1}^6 (V'_{1ij} + V'_{2ij} + V'_{3ij}) - V'_{4j} - V'_{5j} \right] \\
C_j &= \left[\sum_{i=1}^6 (-C_{1ij} - C_{2ij} - C_{3ij}) - C_{4j} - C_{5j} \right]
\end{aligned}$$

Escribiendo la ec. (4.137) seis veces, una para cada $j=1, 2, 3, 4, 5, 6$, obtenemos seis ecuaciones escalares, las cuales se pueden ordenar de la sig. forma:

$$\begin{bmatrix} D_1 \\ D_2 \\ D_3 \\ D_4 \\ D_5 \\ D_6 \end{bmatrix} \ddot{q} + \begin{bmatrix} V_1 \\ V_2 \\ V_3 \\ V_4 \\ V_5 \\ V_6 \end{bmatrix} \dot{q} + \begin{bmatrix} C_1 \\ C_2 \\ C_3 \\ C_4 \\ C_5 \\ C_6 \end{bmatrix} = \begin{bmatrix} Q_1 \\ Q_2 \\ Q_3 \\ Q_4 \\ Q_5 \\ Q_6 \end{bmatrix}$$

$$D'\ddot{q} + V'\dot{q} + C' = Q$$

$$D'\ddot{q} + V'\dot{q} + C' = (J_{\theta}^{-1} J_q)^T \tau + J_{26}^T f_{ext} + J_{27}^T n_{ext}$$

$$D'\ddot{q} + V'\dot{q} + C' + (-J_{26}^T f_{ext} - J_{27}^T n_{ext}) = (J_{\theta}^{-1} J_q)^T \tau$$

$$(J_{\theta}^{-1} J_q)^{-T} D'\ddot{q} + (J_{\theta}^{-1} J_q)^{-T} V'\dot{q} + (J_{\theta}^{-1} J_q)^{-T} C' + (J_{\theta}^{-1} J_q)^{-T} (-J_{26}^T f_{ext} - J_{27}^T n_{ext}) = \tau$$

Finalmente:

$$D\ddot{q} + V\dot{q} + C + E = \tau \quad (4.138)$$

Donde:

$$D = (J_{\theta}^{-1} J_q)^{-T} D'$$

$$V = (J_{\theta}^{-1} J_q)^{-T} V'$$

$$C = (J_{\theta}^{-1} J_q)^{-T} C'$$

$$E = (J_{\theta}^{-1} J_q)^{-T} (-J_{26}^T f_{ext} - J_{27}^T n_{ext})$$

4.3.5. Solución del método Euler-Lagrange

La solución del método de Euler-Lagrange, se obtuvo con ayuda del software Mathematica, y consistió en programar la ecuación (4.138) con cada uno de los términos que la componen. Para el cálculo de la estática se hicieron cero los términos dinámicos (\ddot{q}, \dot{q}) , esto es:

$$C + E = \tau$$

Los datos de masas, inercias y fuerzas externas usadas en este método son las mismas empleadas en el método de Newton-Euler. En la Figura 4.2 se muestra la gráfica de torques obtenida para el análisis estático, correspondiente a la trayectoria trazada en el Apéndice B:



Figura 4.2. Gráfica de torques Estáticos (Lagrange)

En la Figura 4.3 se muestra la gráfica de torques obtenida para el análisis dinámico, correspondiente a la trayectoria trazada en el Apéndice B:

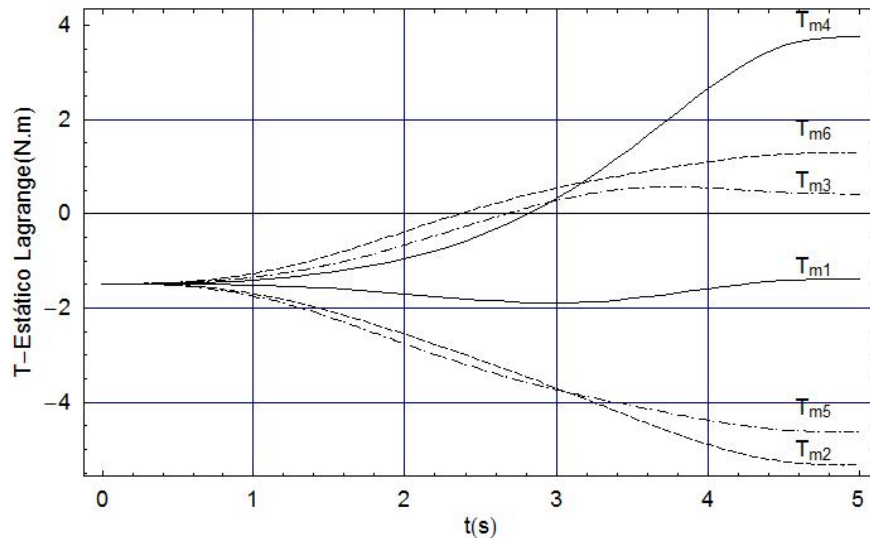

Figura 4.3. Gráfica de torques Dinámicos (Lagrange)

Capítulo 5

Resultados

A continuación se muestra una comparación de los torques estáticos (Figura 5.1) y dinámicos (Figura 5.2), obtenidos con cada uno de los métodos utilizados, para la trayectoria recta.

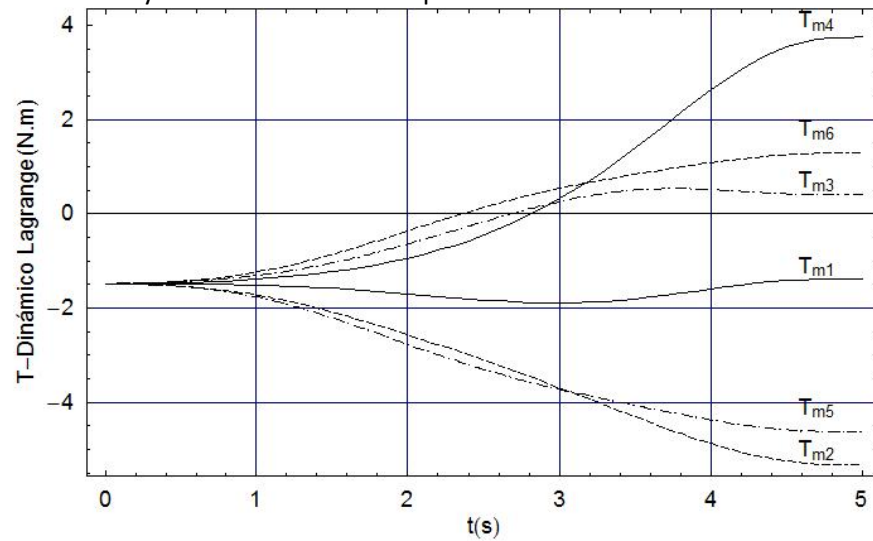

Figura 5.1. Comparación torques estáticos de la recta, Newton vs Lagrange



Figura 5.2. Comparación torques dinámicos de la recta, Newton vs Lagrange

En las figuras 5.1 y 5.2 se puede ver que el método de Newton-Euler y Euler-Lagrange brindan prácticamente el mismo resultado para cada uno de los casos: estático y dinámico; sin embargo no se percibe mucho el efecto de las fuerzas inerciales debidas a las aceleraciones. Con el fin de probar al máximo el modelo dinámico obtenido, se decidió hacer el análisis con una trayectoria, en la cual, el efector final tuviera muchos cambios de dirección y en un corto tiempo, lo cual provocaría picos en la aceleración y por consecuencia la inercia de los cuerpos sería muy considerable en el cálculo de los torques requeridos por los motores. De esta forma la trayectoria mencionada (Helicoide compuesto) se asemejaría bastante a una aplicación del robot y se describe en el apéndice G.

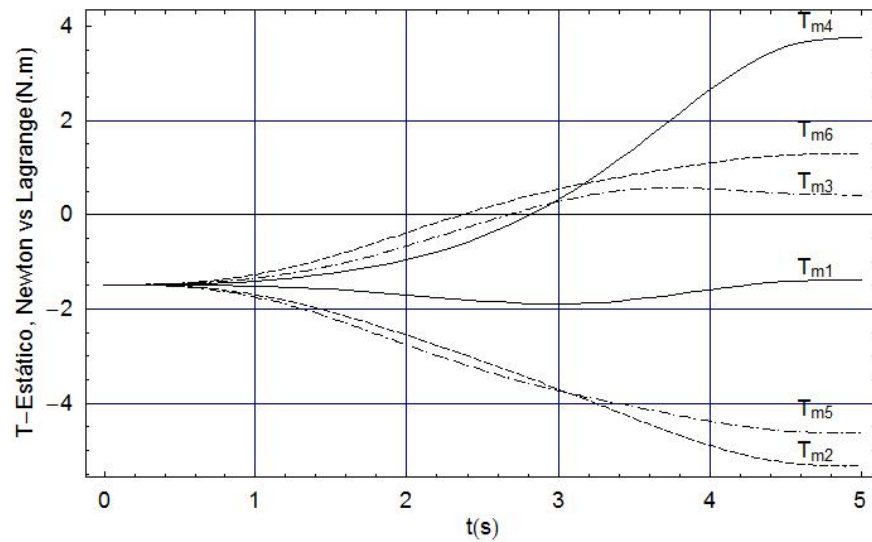
A continuación se muestra una comparación de las diferentes gráficas de torques, obtenidas con cada uno de los métodos utilizados, para la trayectoria del helicoide compuesto. Cabe mencionar que para para la comparación de los torques estáticos obtenidos por los métodos Newton y Lagrange, no se presenta la gráfica el error absoluto entre dichas gráficas, ya que en los seis torques el mayor error que se tiene es de 1×10^{-12} y se considera despreciable. Sin embargo, para los torques dinámicos las gráficas de error si se mostrarán posteriormente.

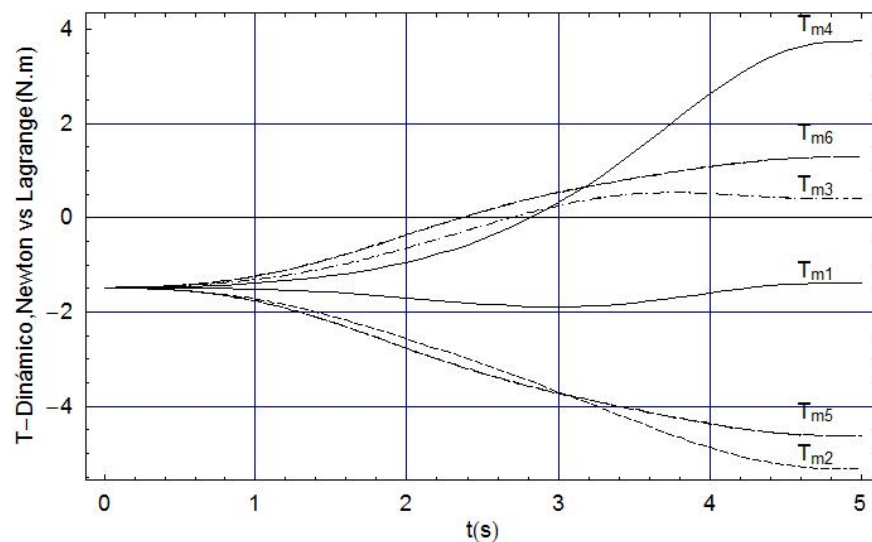

Figura 5.3. Comparación torques estáticos del helicoide compuesto, Newton vs Lagrange

Con el fin de mostrar con claridad los torques dinámicos, se presentan por separado las comparaciones de cada uno de los torques, y además se mostrarán (inmediatamente después de las gráficas de comparación de los mismos) las gráficas de errores absolutos para cada uno de los torques obtenidos por los métodos de Newton y Lagrange. Se hace notar que en las 6 gráficas de error, los valores de error más grandes se dan entre el tiempo 0.5 y 1.5 segundos, que es en donde se obtienen los torque más grandes, esto, debido a que en ese lapso el efector final del robot debe seguir la trayectoria helicoidal. Por lo tanto, al tener torques más grandes en ese periodo, se tiene que el error relativo no es tan grande.

Los errores obtenidos se pueden deber a la forma en que se calcularon los torques con cada uno de los métodos descritos, por ejemplo: en el método de Newton se hace uso de un método numérico, lo cual puede generar un error. Por otro lado, en el método de Lagrange, se requirieron hacer varias derivadas totales y parciales que incluían bastantes variables (con valores con muchos decimales) calculadas precedentemente en el programa en Mathematica, lo cual puede generar también un error, Además, en este mismo método se requirieron obtener las inversas de algunas matrices.

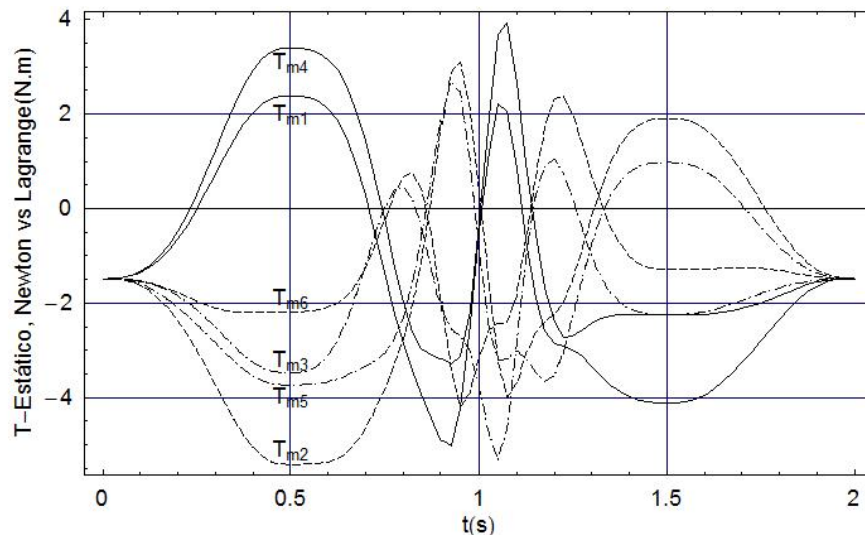

Figura 5.4. Comparación torque 1 dinámico del helicoide compuesto, Newton vs Lagrange



Figura 5.5. Error absoluto, torque 1 dinámico del helicoide compuesto, Newton vs Lagrange

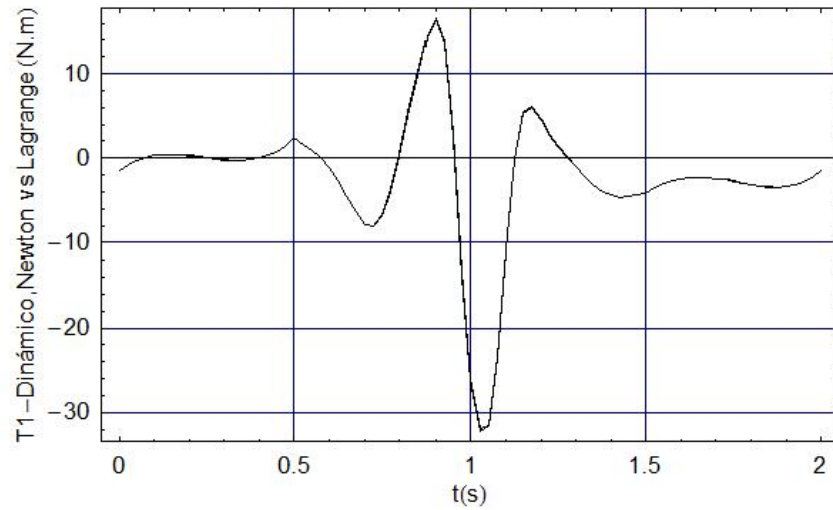

Figura 5.6. Comparación torque 2 dinámico del helicoide compuesto, Newton vs Lagrange

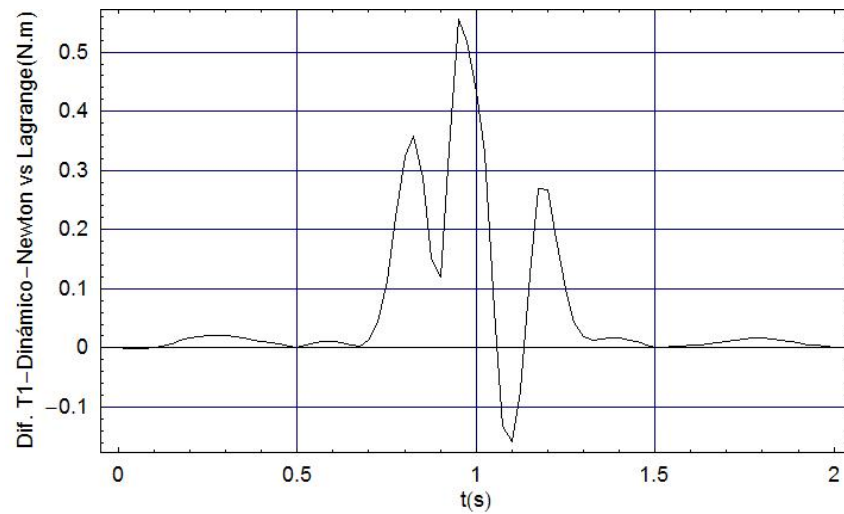

Figura 5.7. Error absoluto, torque 2 dinámico del helicoides compuesto, Newton vs Lagrange

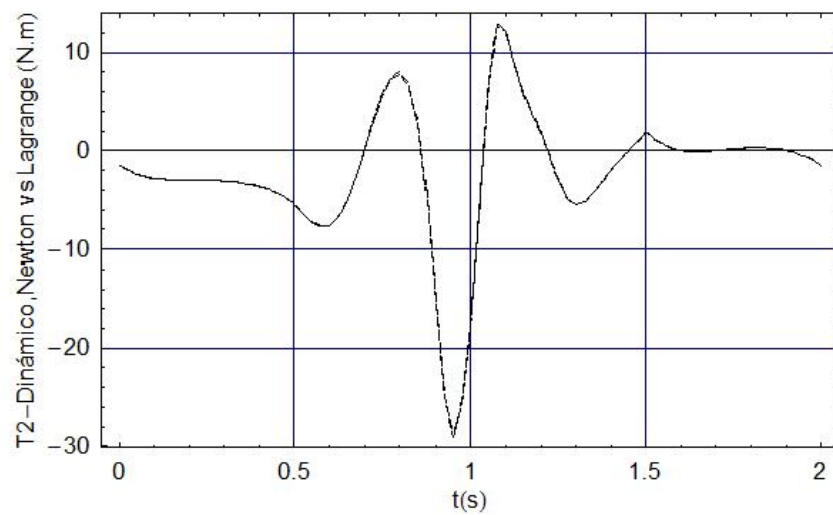

Figura 5.8. Comparación torque 3 dinámico del helicoides compuesto, Newton vs Lagrange

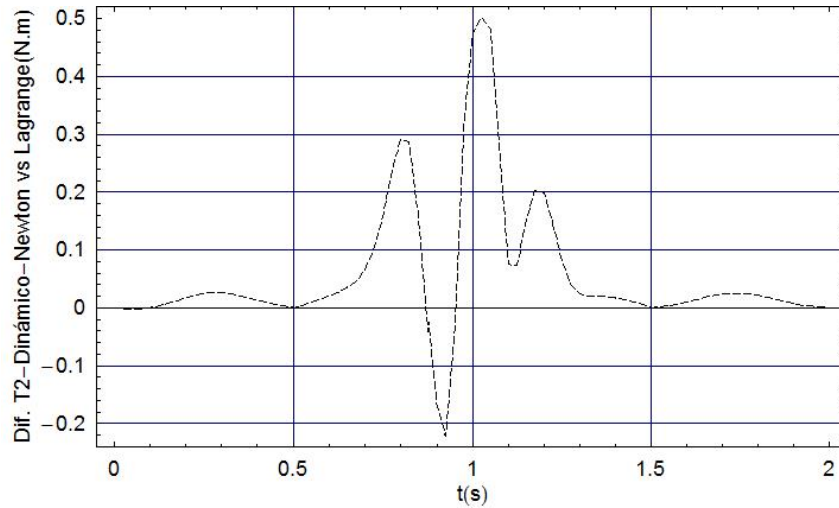

Figura 5.9. Error absoluto, torque 3 dinámico del helicoides compuesto, Newton vs Lagrange

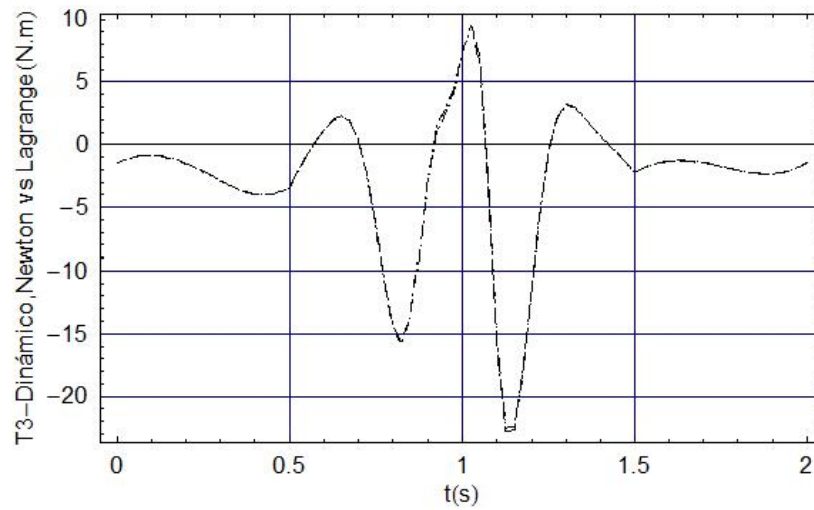

Figura 5.10. Comparación torque 4 dinámico del helicoide compuesto, Newton vs Lagrange

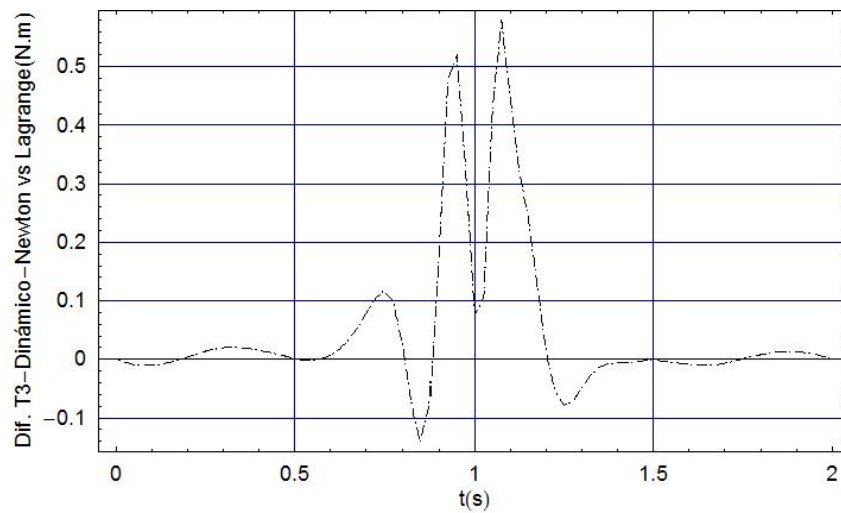

Figura 5.11. Error absoluto, torque 4 dinámico del helicoide compuesto, Newton vs Lagrange

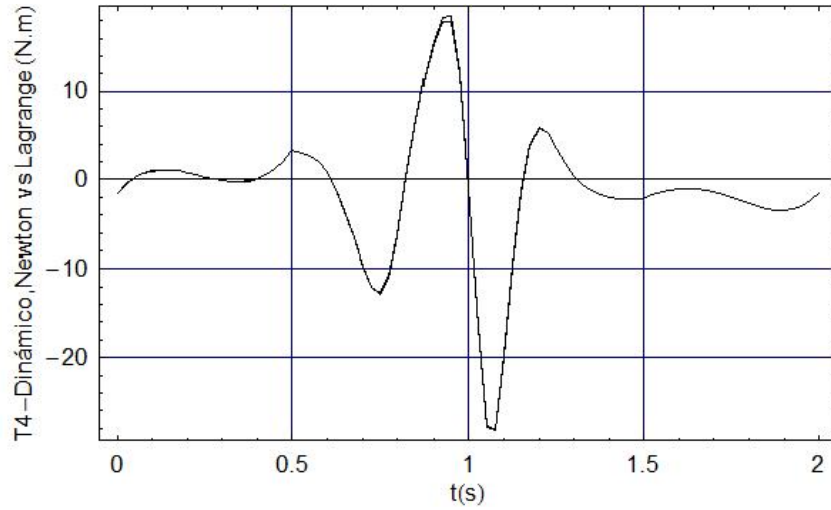

Figura 5.12. Comparación torque 5 dinámico del helicoide compuesto, Newton vs Lagrange

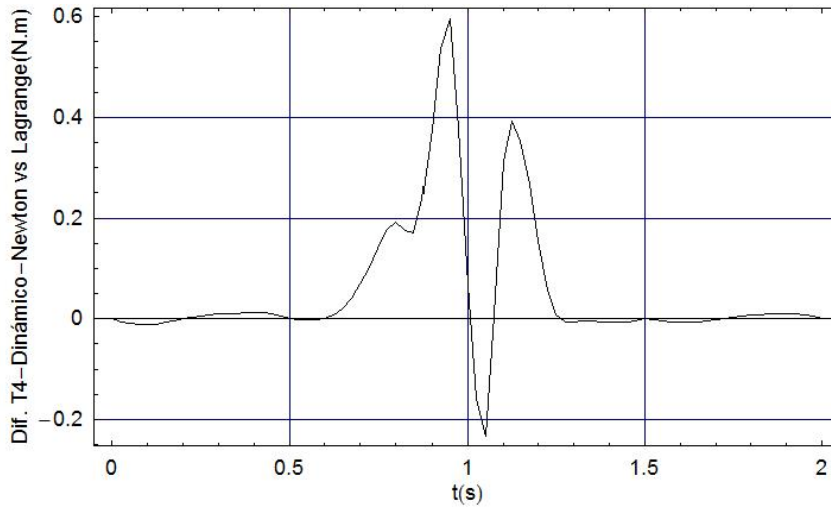

Capítulo 6

Conclusiones

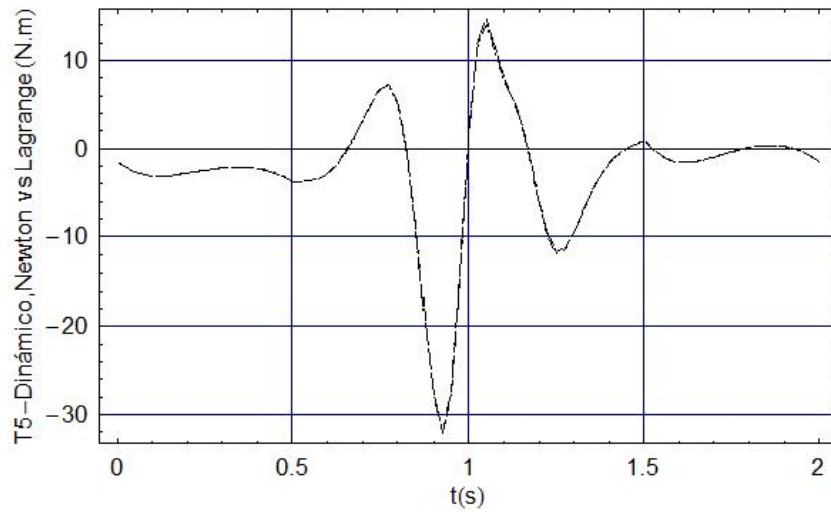
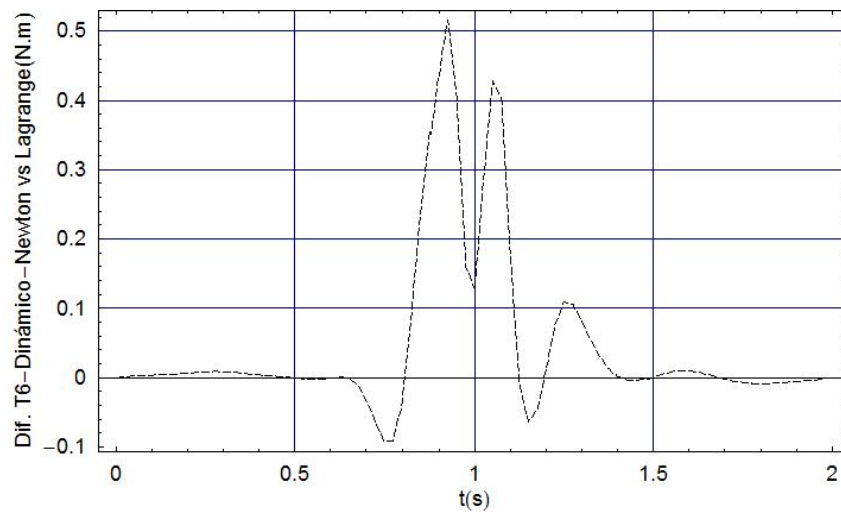
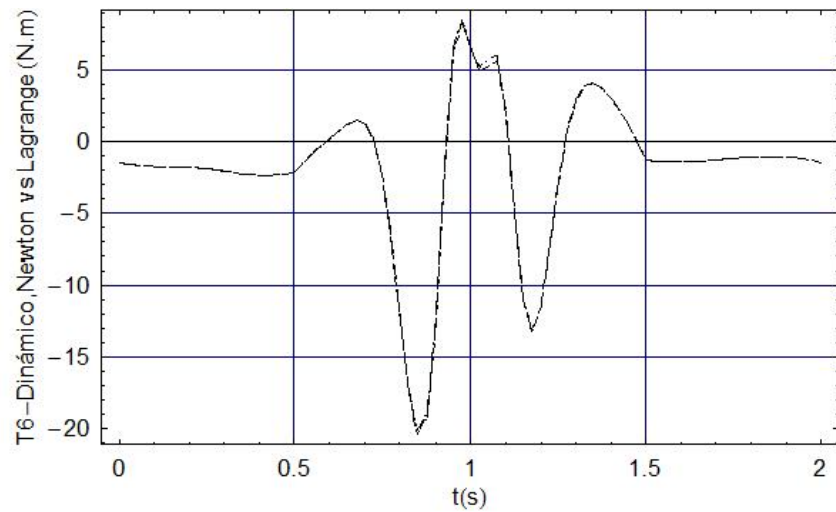
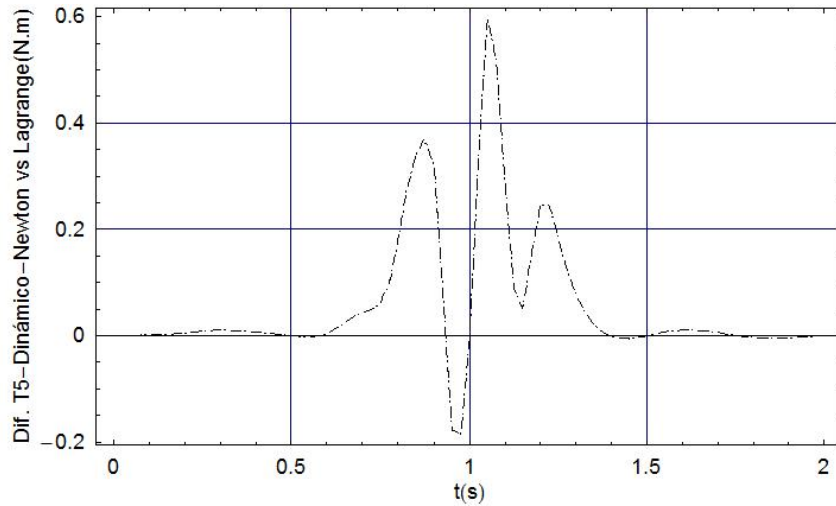
En el análisis cinemático, el uso de las matrices de transformación homogéneas, como herramienta matemática, brinda mucha más libertad en el desarrollo y permite ver más claramente el uso y propiedades de las mismas, lo que desde mi punto de vista es una ventaja sobre el método de Denavit- Hartenberg, además de que con este último método se hace muy difícil representar una junta esférica, y es por ese motivo que no se usó en este trabajo; también permiten solucionar la posición de forma algebraica o bien con la ayuda de un método numérico, teniendo este último la desventaja de que para cada trayectoria se requiere un nuevo conjunto de ecuaciones para solucionar, ya que cada conjunto se comporta numéricamente diferente.

Por otro lado, dada la posición y orientación del efector final, se calculó la orientación de los ángulos en las articulaciones de los eslabones, obteniéndose así una ecuación para cada uno de los 6 ángulos por cadena cinemática. Varias de las ecuaciones mencionadas anteriormente contienen el término $\arctan(x)$, el cual genera un problema en el cálculo, ya que puede tener varios resultados dependiendo del cuadrante en que se encuentre, dicho problema se solucionó usando la función $\arctan2$ programada en el software Mathematica, la cual toma en cuenta en que cuadrante se encuentra el punto.

A lo largo del desarrollo del análisis cinemático se realizaron diversas simulaciones con diferentes trayectorias como son: una recta, mostrada en el Apéndice B; el helicoide compuesto, mostrada en el Apéndice G; Spline, esta trayectoria permite pasar por un conjunto de puntos dados de forma deliberada, este trabajo quedó pendiente al no obtenerse la velocidad y aceleración de la misma por cuestiones de tiempo; entre otras. Las simulaciones mencionadas anteriormente nos permiten demostrar que el efector final del manipulador puede seguir una infinidad de trayectorias dentro de su área de trabajo, y a su vez gracias a la posición y orientación del mismo, nos permite pensar en aplicaciones de tomar y colocar, centros de maquinado, soldadoras y punteadoras, simuladores, equipo médico y todas aquellas que requieran altas velocidades, alta precisión y/o altas capacidades de carga.

En el análisis dinámico formulación Newton-Euler, se usaron diferentes bases locales, las cuales evitaron que las ecuaciones estén más cargadas de información (con los ángulos de las matrices de rotación), tal como sucede con el uso de bases inerciales, ya que es necesario proyectar cada uno de los torsores a esta última. De esta forma, se pueden usar tantas bases locales como se quiera, y siempre y cuando sean usadas de forma correcta el resultado debe ser el mismo que el obtenido con bases inerciales.

En el análisis dinámico formulación Euler-Lagrange, se usaron ambas, bases locales e inerciales; las primeras se usaron para el cálculo de la energía cinética de los eslabones, ya que existe un

producto punto y no importa en qué base se realice siempre y cuando los vectores estén proyectados en la misma base; la segunda se usó para el cálculo de la energía potencial, ya que en este caso, por facilidad, se decidió que todos los vectores de centro de gravedad de los cuerpos estén proyectados en la misma base. Una dificultad que se encontró en el uso de las bases locales fue el hecho de que, al derivar esos vectores respecto al tiempo o las coordenadas generalizadas, no dependen explícitamente de esas variables, lo cual requiere un mayor entendimiento y perspectiva de la física de cada uno de los vectores, pero no debe ser un impedimento para el cálculo de las mismas.

Para la construcción e implementación del robot se requiere tener un cúmulo de información que permita lograr este objetivo. Dicha información se obtiene de las dos formulaciones desarrolladas en este trabajo:

La primera es la formulación Newton-Euler; que gracias a que toma en cuenta las fuerzas de restricción, inerciales, debidas a los pesos etc.; brinda la información necesaria para diseñar cada uno de los elementos mecánicos del robot (pernos, rodamientos, geometría de las barras, etc.), hacer un análisis de elemento finito de cada elementos que componen el mismo, diseño de la base del robot para evitar vibraciones, etc.

La segunda es la formulación Euler-Lagrange que permite obtener un modelo matemático adecuado para la mayoría de los esquemas de control, una ventaja particular del modelo obtenido en este trabajo es que es un modelo que incluye un gran número de variables (mucho más de las que se incluyen en los modelos simplificados, los cuales son muy usados debido a su facilidad de cálculo), ya que no se hace ningún tipo de simplificación.

Por último, haciendo una comparación de los resultados dinámicos obtenidos con cada una de las formulaciones para las dos trayectorias presentadas, se puede concluir que los resultados son correctos, ya que, aunque el hecho de que los resultados sean muy similares no implica que los resultados sean correctos, se puede decir en este caso que sí lo son, debido a que la naturaleza de cada uno de los métodos es muy distinta y hay pocas probabilidades de que tengan el mismo error o errores que se compensen. Finalmente, si alguien decidiera continuar con la construcción e implementación del robot, puede tomar la información presentada en este trabajo como base para su desarrollo.

Bibliografía

Angeles, Jorge. 1997. *Fundamentals of Robotic Mecanical Sitems*. Montreal Quebec : Springer, 1997.

Arai, T, et al. 1991. Development of Parallel Link Manipulator for Underground Excavation Task. *Proc. 1991 International Symposium on Advanced Robot Technology*. 1991. pp. 541-548.

Clavel, R. 1988. A Fast Robot with Parallel Geometry. *Proc. 18th International Symposium on Industrial Robots*. 1988. pp. 91-100.

Dynamic Modeling of Parallel Robots for Computed-Torque Control Implementation. **Codourey, Alain. 1998.** s.l. : sagepublications, 1998, Vol. The International Journal of Robotics Research 1998; 17; 1325.

Flores, Shair Mendoza. 2006. *Análisis Cinemático y Dinámico de un Robot Delta de 3 Grados de Libertad*. México. D.F. : s.n., 2006.

Giddings & Lewis. 1995. Giddings and Lewis Machine Tool. *Fond du Lac*. 1995.

Gosselin, Clement and Hamel, J. 1994. The Agile Eye: A High-Performance Three Degree-of-Freedom Camera-Orienting Device. *Proc. IEEE International Conference on Robotics and Automation*. 1994. pp. 781-786.

Instantaneous Kinematics and Singularity Analysis of Three-legged Parallel Manipulators. **Dash, Anjan Kumar, et al. 2003.** Hawaii : s.n., 2003, Vol. International Conference on Intelligent Robots and Systems.

Inverse Dynamics of Hexa Parallel Robot Using Lagrangian Dynamics Formulation. **Ahmadi, Mahdi, et al. 2008.** Florida : IEEE, 2008, Vols. 12th International Conference on Intelligent Engineering Systems • February 25–29.

McGill, David J. and W. King, Wilton. 1991. *Mecánica para ingeniería y sus aplicaciones. Dinámica*. s.l. : Grupo Editorial Iberoamérica, 1991.

Merlet, Jean Pierre. 2000. *Parallel Robots*. s.l. : Kluwer Academic Publishers, 2000.

Pierrot, F., Fournier, A. and Dauchez, P. 1991. Toward a Fully Parallel 6-DOF Robot for High-Speed Applications. *Proc. 1991 IEEE International Conference on Robotics and Automation*. 1991. pp. 1288-1293.

Reinholtz, C and Gakhale, D. Design an Analysis of Variable Geometry Truss Robot. *Proc. 9th Applied Mechanisms Conference*. Oklahoma State University, Stillwater. OK : s.n.

Singularity Analysis and Representation of the General Gough-Stewart Platform. **St-Onge, Boris Mayer and Gosselin, Clément M. 2000.** Québec : Sage Publications, 2000, Vol. The International Journal of Robotics Research 2000; 19; 271.

Spong, Mark W. and Vidyasagar, M. 1989. *Robot Dynamics and Control*. s.l. : John Wiley & Sons, 1989. pp. 129-133.

Stejskal, Vladimír and Valásek, Michael. 1996. *Kinematics and Dynamics of Machinery*. s.l. : Marcel Dekker, Inc., 1996.

Stewart, D. 1965. A platform with 6 degrees of freedom. *Proc. Institution of Mechanical Engineers*. 1965. Vol. 180, pp. 371-386.

Tsai, Lun Wen. 1999. *"Robot Analysis" The mechanics of serial and parallel manipulators*. s.l. : John Wiley & Sons, 1999.

Waldron, K. J., et al. 1984. Configuration Design of the Adaptive Suspension Vehicle. *Int. J. Robot. Res.* 1984. Vol. 3, pp. 37-48.

Apéndice A

Ecuación trascendental

Para resolver la ecuación (2.8) procedemos a hacer las siguientes operaciones:

$$Ac\theta + Bs\theta + C = 0 \quad (\text{a.1})$$

Haciendo cambios de variable se tiene:

$$A\left(\frac{1-t^2}{1+t^2}\right) + B\left(\frac{2t}{1+t^2}\right) + C = 0 \quad (\text{a.2})$$

Donde:

$$c\theta = \frac{1-t^2}{1+t^2} \quad (\text{a.3})$$

$$s\theta = \frac{2t}{1+t^2} \quad (\text{a.4})$$

Desarrollando la ecuación (a.2):

$$A + C + 2Bt - At^2 + Ct^2 = 0$$

Ahora obteniendo las raíces de la ecuación anterior se tiene:

$$t_{1,2} = \frac{B \pm \sqrt{A^2 + B^2 - C^2}}{A - C} \quad (\text{a.5})$$

Sabemos que:

$$\tan \frac{\theta}{2} = \frac{s\theta}{1+c\theta}$$

Sustituyendo las ecuaciones (a.3) y (a.4) en la ecuación anterior y simplificando:

$$\tan \frac{\theta}{2} = t \quad (\text{a.6})$$

Sustituyendo la ecuación (a.6) en (a.5):

$$\tan \frac{\theta}{2} = \frac{B \pm \sqrt{A^2 + B^2 - C^2}}{A - C}$$

Resolviendo la ecuación anterior:

$$\theta_{1,2} = 2 \arctan \left[\frac{B \pm \sqrt{A^2 + B^2 - C^2}}{A - C} \right] \quad (\text{a.7})$$

Apéndice B

Generación de trayectoria

El movimiento de un cuerpo en el espacio consiste de dos partes. Una trayectoria lineal o curva en el espacio que sigue un punto del cuerpo (el centro de gravedad o el órgano terminal de un manipulador) y la orientación angular del cuerpo. Ambas partes deben satisfacer condiciones de posición, velocidad y aceleración tanto lineal como angular y ser realizadas en un tiempo determinado. A continuación se desarrollan la trayectoria lineal y angular del cuerpo en función del tiempo.

Trayectoria lineal

Se define la curva en el espacio como una recta para el movimiento a seguir por un punto del cuerpo.



Figura b.0.1. Trayectoria recta

La ecuación vectorial de posición se define a partir de la figura anterior:

$$\begin{aligned} \mathbf{R} &= \mathbf{Q} + \mathbf{S} \\ &= \mathbf{Q} + s\mathbf{u} \end{aligned}$$

Donde s es la magnitud del vector \mathbf{S} y \mathbf{u} es el vector unitario que define la orientación de \mathbf{S} . Para definir \mathbf{R} en función del tiempo, se requiere que la magnitud s , cambie con respecto al mismo, es decir:

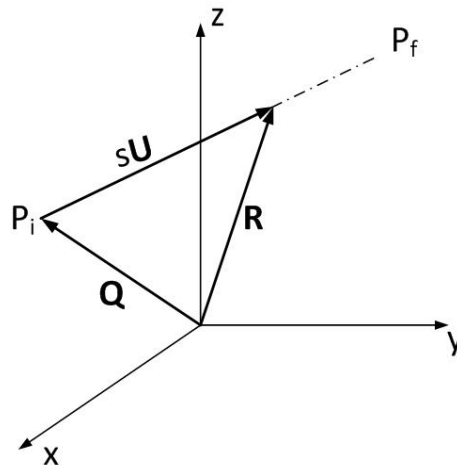
$$\mathbf{R}(t) = \mathbf{Q} + s(t)\mathbf{u} \quad (\text{b.1})$$

A partir de la ec. (b.1), las ecs. vectoriales de velocidad y aceleración se definen como la primera y segunda derivada respecto al tiempo:

$$\begin{aligned} \mathbf{V}(t) &= \dot{s}(t) \mathbf{u} \\ \mathbf{A}(t) &= \ddot{s}(t) \mathbf{u} \end{aligned} \quad (\text{b.2})$$

Donde \mathbf{Q} y \mathbf{u} no varían respecto al tiempo, ya que están definidos por puntos fijos en el espacio. La magnitud $s(t)$ debe satisfacer condiciones iniciales y finales de posición, velocidad y aceleración, es decir debe satisfacer 6 condiciones, según se muestra en la siguiente figura:



Figura b.0.2. Graficas del perfil quintico

La primera gráfica indica el cambio de magnitud del vector \mathbf{S} , que irá variando de 0 para un tiempo inicial t_0 a h para un tiempo final t_f , t_0 y t_f son definidos de manera arbitraria, donde $h = \|\mathbf{S}\|$.

La segunda gráfica es la rapidez con que la magnitud del vector \mathbf{S} cambia respecto al tiempo. Es decir, es la rapidez con que realiza el traslado del punto p_i a p_f , para un tiempo inicial t_0 y un tiempo final t_f .

La tercera gráfica es el cambio de la rapidez (aceleración) con que la magnitud del vector \mathbf{S} cambia respecto al tiempo, para un tiempo inicial t_0 y un tiempo final t_f .

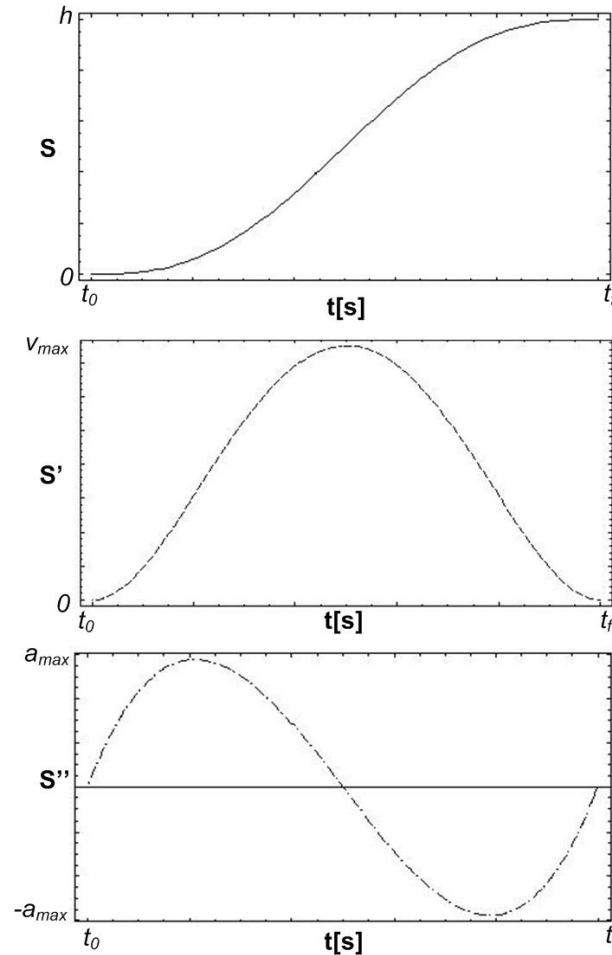
Para satisfacer las 6 condiciones, se empleará un polinomio de quinto grado, ya que este cuenta con 6 coeficientes a determinar. De esta manera, se tiene:

$$\begin{aligned} s(t) &= a_0 + a_1 t + a_2 t^2 + a_3 t^3 + a_4 t^4 + a_5 t^5 \\ \dot{s}(t) &= a_1 + 2 a_2 t + 3 a_3 t^2 + 4 a_4 t^3 + 5 a_5 t^4 \\ \ddot{s}(t) &= 2 a_2 + 6 a_3 t + 12 a_4 t^2 + 20 a_5 t^3 \end{aligned} \tag{b.3}$$

Debido a que existen condiciones iniciales y finales de velocidad y aceleración, se obtienen las derivadas respecto al tiempo del polinomio de $s(t)$. Para $t_0 = t = 0$ (el valor de 0, es asignado arbitrariamente) se tienen las 3 condiciones iniciales:

$$\begin{aligned} s(t_0) &= s(0) = 0 \\ \dot{s}(t_0) &= \dot{s}(0) = 0 \\ \ddot{s}(t_0) &= \ddot{s}(0) = 0 \end{aligned} \tag{b.4}$$

Al sustituirlos en las ecs. (b.3) se obtienen:

$$\begin{aligned} s(0) = 0 &= a_0 + a_1 (0) + a_2 (0)^2 + a_3 (0)^3 + a_4 (0)^4 + a_5 (0)^5 \\ \dot{s}(0) = 0 &= a_1 + 2 a_2 (0) + 3 a_3 (0)^2 + 4 a_4 (0)^3 + 5 a_5 (0)^4 \\ \ddot{s}(0) = 0 &= 2 a_2 + 6 a_3 (0) + 12 a_4 (0)^2 + 20 a_5 (0)^3 \end{aligned}$$

Simplificando:

$$\begin{aligned} 0 &= a_0 \\ 0 &= a_1 \\ 0 &= 2a_2 \end{aligned}$$

Finalmente los tres primeros coeficientes son:

$$\begin{aligned} a_0 &= 0 \\ a_1 &= 0 \\ a_2 &= 0 \end{aligned} \tag{b.5}$$

Repetiendo el proceso para $t = t_f$ se tienen las 3 condiciones finales:

$$\begin{aligned} s(t_f) &= h = \| \mathbf{p}_f - \mathbf{p}_i \| \\ \dot{s}(t_f) &= 0 \\ \ddot{s}(t_f) &= 0 \end{aligned} \tag{b.6}$$

Donde $\mathbf{p}_i = (x_i, y_i, z_i)$ y $\mathbf{p}_f = (x_f, y_f, z_f)$ significan coordenadas de los puntos inicial y final de la trayectoria respectivamente, la magnitud de la diferencia entre ellos, representa la distancia h que necesitamos recorrer en la línea recta. Al sustituir ecs. (b.5) y (b.6) en (b.3) se obtiene:

$$\begin{aligned} \| \mathbf{p}_f - \mathbf{p}_i \| &= a_3 t_f^3 + a_4 t_f^4 + a_5 t_f^5 \\ 0 &= 3 a_3 t_f^2 + 4 a_4 t_f^3 + 5 a_5 t_f^4 \\ 0 &= 6 a_3 t_f + 12 a_4 t_f^2 + 20 a_5 t_f^3 \end{aligned}$$

El sistema de ecs. resultante se expresa de la siguiente manera:

$$\begin{bmatrix} t_f^3 & t_f^4 & t_f^5 \\ 3t_f^2 & 4t_f^3 & 5t_f^4 \\ 6t_f & 12t_f^2 & 20t_f^3 \end{bmatrix} \begin{bmatrix} a_3 \\ a_4 \\ a_5 \end{bmatrix} = \begin{bmatrix} \|\mathbf{p}_f - \mathbf{p}_i\| \\ 0 \\ 0 \end{bmatrix} \quad (\text{b.7})$$

Al resolver el sistema de la ec. (b.7) se obtienen los 3 últimos coeficientes:

$$\begin{aligned} a_3 &= 10 \frac{\|\mathbf{p}_f - \mathbf{p}_i\|}{t_f^3} \\ a_4 &= -15 \frac{\|\mathbf{p}_f - \mathbf{p}_i\|}{t_f^4} \\ a_5 &= 6 \frac{\|\mathbf{p}_f - \mathbf{p}_i\|}{t_f^5} \end{aligned} \quad (\text{b.8})$$

Sustituyendo las ecuaciones (b.5) y (b.8) en (b.3):

$$\begin{aligned} s(t) &= 10 \frac{\|\mathbf{p}_f - \mathbf{p}_i\|}{t_f^3} t^3 - 15 \frac{\|\mathbf{p}_f - \mathbf{p}_i\|}{t_f^4} t^4 + 6 \frac{\|\mathbf{p}_f - \mathbf{p}_i\|}{t_f^5} t^5 \\ \dot{s}(t) &= 30 \frac{\|\mathbf{p}_f - \mathbf{p}_i\|}{t_f^3} t^2 - 60 \frac{\|\mathbf{p}_f - \mathbf{p}_i\|}{t_f^4} t^3 + 30 \frac{\|\mathbf{p}_f - \mathbf{p}_i\|}{t_f^5} t^4 \\ \ddot{s}(t) &= 60 \frac{\|\mathbf{p}_f - \mathbf{p}_i\|}{t_f^3} t - 180 \frac{\|\mathbf{p}_f - \mathbf{p}_i\|}{t_f^4} t^2 + 120 \frac{\|\mathbf{p}_f - \mathbf{p}_i\|}{t_f^5} t^3 \end{aligned}$$

Finalmente, factorizando se obtienen las ecuaciones que representan el cambio de la magnitud de la posición, velocidad y aceleración en función del tiempo:

$$\begin{aligned} s(t) &= \|\mathbf{p}_f - \mathbf{p}_i\| \left[10 \frac{t^3}{t_f^3} - 15 \frac{t^4}{t_f^4} + 6 \frac{t^5}{t_f^5} \right] \\ \dot{s}(t) &= \|\mathbf{p}_f - \mathbf{p}_i\| \left[30 \frac{t^2}{t_f^3} - 60 \frac{t^3}{t_f^4} + 30 \frac{t^4}{t_f^5} \right] \\ \ddot{s}(t) &= \|\mathbf{p}_f - \mathbf{p}_i\| \left[60 \frac{t}{t_f^3} - 180 \frac{t^2}{t_f^4} + 120 \frac{t^3}{t_f^5} \right] \end{aligned} \quad (\text{b.9})$$

Donde t = tiempo para realizar el movimiento y t_f = tiempo final para terminar el movimiento. Reescribiendo las ecs. (b.1) y (b.2) en función de los puntos de la recta:

$$\begin{aligned} \mathbf{R}(t) &= \mathbf{Q} + s(t) \mathbf{u} = (\mathbf{p}_i - 0) + s(t) \frac{(\mathbf{p}_f - \mathbf{p}_i)}{\|\mathbf{p}_f - \mathbf{p}_i\|} \\ \mathbf{V}(t) &= \dot{s}(t) \mathbf{u} = \dot{s}(t) \frac{(\mathbf{p}_f - \mathbf{p}_i)}{\|\mathbf{p}_f - \mathbf{p}_i\|} \\ \mathbf{A}(t) &= \ddot{s}(t) \mathbf{u} = \ddot{s}(t) \frac{(\mathbf{p}_f - \mathbf{p}_i)}{\|\mathbf{p}_f - \mathbf{p}_i\|} \end{aligned} \quad (\text{b.10})$$

Sustituyendo ecs. (b.9) en ecs. (b.10), se obtienen finalmente las ecuaciones vectoriales de posición, velocidad y aceleración que debe seguir la plataforma móvil:

$$\begin{aligned}
 \mathbf{R}(t) &= \mathbf{p}_i + \left[10 \frac{t^3}{t_f^3} - 15 \frac{t^4}{t_f^4} + 6 \frac{t^5}{t_f^5} \right] (\mathbf{p}_f - \mathbf{p}_i) \\
 \mathbf{V}(t) &= \mathbf{p}_i + \left[30 \frac{t^2}{t_f^3} - 60 \frac{t^3}{t_f^4} + 30 \frac{t^4}{t_f^5} \right] (\mathbf{p}_f - \mathbf{p}_i) \\
 \mathbf{A}(t) &= \mathbf{p}_i + \left[60 \frac{t}{t_f^3} - 180 \frac{t^2}{t_f^4} + 120 \frac{t^3}{t_f^5} \right] (\mathbf{p}_f - \mathbf{p}_i)
 \end{aligned} \tag{b.11}$$

Orientación angular

Para la orientación se sigue un procedimiento similar, aclarando que para este caso, solo se desea pasar de valores iniciales a finales, para la posición, velocidad y aceleración angular de la plataforma móvil, ya que no se requiere cumplir con una trayectoria particular en el espacio. Esto conducirá a las siguientes ecuaciones:

$$\begin{aligned}
 \boldsymbol{\beta}(t) &= \boldsymbol{\beta}_i + \left[10 \frac{t^3}{t_f^3} - 15 \frac{t^4}{t_f^4} + 6 \frac{t^5}{t_f^5} \right] (\boldsymbol{\beta}_f - \boldsymbol{\beta}_i) \\
 \dot{\boldsymbol{\beta}}(t) &= \boldsymbol{\beta}_i + \left[30 \frac{t^2}{t_f^3} - 60 \frac{t^3}{t_f^4} + 30 \frac{t^4}{t_f^5} \right] (\boldsymbol{\beta}_f - \boldsymbol{\beta}_i) \\
 \ddot{\boldsymbol{\beta}}(t) &= \boldsymbol{\beta}_i + \left[60 \frac{t}{t_f^3} - 180 \frac{t^2}{t_f^4} + 120 \frac{t^3}{t_f^5} \right] (\boldsymbol{\beta}_f - \boldsymbol{\beta}_i)
 \end{aligned} \tag{b.12}$$

Donde el vector $\boldsymbol{\beta} = [\psi, \theta, \phi]$. De la misma manera $\boldsymbol{\beta}_i = [\psi_i, \theta_i, \phi_i]$ y $\boldsymbol{\beta}_f = [\psi_f, \theta_f, \phi_f]$ se refieren a los valores iniciales y finales.

Apéndice C

Coeficientes de la ecuación (2.45):

$$V_{8i} = -a_{34i}$$

$$V_{9i} = -(c\theta_{8i}^2(c\delta_{6i}s(\delta_i + \delta_{3i}) + c(\delta_i + \delta_{3i})(c\theta_{4i}s\delta_{6i} - s\theta_{4i}\tan\theta_{8i})))$$

$$V_{10i} = c\theta_{8i}^2(c(\delta_i + \delta_{3i})c\delta_{6i} + s(\delta_i + \delta_{3i})(-c\theta_{4i}s\delta_{6i}) + s\theta_{4i}\tan\theta_{8i}))$$

$$V_{11i} = c\theta_{8i}^2(s\delta_{6i}s\theta_{4i} + c\theta_{4i}\tan\theta_{8i})$$

$$V_{12i} = c\theta_{8i}^2((x_{16i}s\delta_{17i} + x_{14i}s(\delta_{15i} + \delta_{17i}))(-c\delta_{6i}c(\delta_i + \delta_{3i} - \psi)s\phi) + c\theta_{4i}c\psi s(\delta_i + \delta_{3i})s\delta_{6i}s\phi + c\delta_{6i}c\theta c\phi s(\delta_i + \delta_{3i} - \psi) + c\theta c\theta_{4i}c\phi s(\delta_i + \delta_{3i})s\delta_{6i}s\psi + c(\delta_i + \delta_{3i})c\theta_{4i}s\delta_{6i}(c\theta c\phi c\psi - s\phi s\psi) - c\theta c\phi c(\delta_i + \delta_{3i} - \psi)s\theta_{4i}\tan\theta_{8i} - s\theta_{4i}s\phi s(\delta_i + \delta_{3i} - \psi)\tan\theta_{8i}) - x_{16i}c\delta_{17i}(c\delta_{6i}(c\phi c(\delta_i + \delta_{3i} - \psi) + c\theta s\phi s(\delta_i + \delta_{3i} - \psi)) + (c\theta c(\delta_i + \delta_{3i} - \psi)s\phi - c\phi s(\delta_i + \delta_{3i} - \psi)))(c\theta_{4i}s\delta_{6i} - s\theta_{4i}\tan\theta_{8i})) - x_{14i}c(\delta_{15i} + \delta_{17i})(c\delta_{6i}(c\phi c(\delta_i + \delta_{3i} - \psi) + c\theta s\phi s(\delta_i + \delta_{3i} - \psi)) + (c\theta c(\delta_i + \delta_{3i} - \psi)s\phi - c\phi s(\delta_i + \delta_{3i} - \psi)))(c\theta_{4i}s\delta_{6i} - s\theta_{4i}\tan\theta_{8i})))$$

$$V_{13i} = c\theta_{8i}^2(-(c\phi c\psi(x_{16i}s\delta_{17i} + x_{14i}s(\delta_{15i} + \delta_{17i}))(c\delta_{6i} + \delta_{3i}c\delta_{6i} - c\theta_{4i}s(\delta_i + \delta_{3i})s\delta_{6i})s\theta) + c\theta c\phi(x_{16i}s\delta_{17i} + x_{14i}s(\delta_{15i} + \delta_{17i}))s\delta_{6i}s\theta_{4i} + (x_{16i}c\delta_{17i} + x_{14i}c(\delta_{15i} + \delta_{17i}))c\delta_{6i}c\delta_{6i} + \delta_{3i} - \psi s\theta s\phi - (x_{16i}c\delta_{17i} + x_{14i}c(\delta_{15i} + \delta_{17i}))c\theta s\delta_{6i}s\theta_{4i}s\phi - (x_{16i}c\delta_{17i} + x_{14i}c(\delta_{15i} + \delta_{17i}))c\theta_{4i}s\delta_{6i}s\theta s\phi s(\delta_i + \delta_{3i} - \psi) - c\phi(x_{16i}s\delta_{17i} + x_{14i}s(\delta_{15i} + \delta_{17i}))(c\delta_{6i}s(\delta_i + \delta_{3i}) + c(\delta_i + \delta_{3i})c\theta_{4i}s\delta_{6i})s\theta s\psi + c\theta c\theta_{4i}c\phi(x_{16i}s\delta_{17i} + x_{14i}s(\delta_{15i} + \delta_{17i}))\tan\theta_{8i} - (x_{16i}c\delta_{17i} + x_{14i}c(\delta_{15i} + \delta_{17i}))c\theta c\theta_{4i}s\psi\tan\theta_{8i} + (x_{16i}c\delta_{17i} + x_{14i}c(\delta_{15i} + \delta_{17i}))c\psi s(\delta_i + \delta_{3i})s\theta s\theta_{4i}s\psi\tan\theta_{8i} - c\phi(x_{16i}s\delta_{17i} + x_{14i}s(\delta_{15i} + \delta_{17i}))s\theta s\theta_{4i}s(\delta_i + \delta_{3i} - \psi)\tan\theta_{8i} - (x_{16i}c\delta_{17i} + x_{14i}c(\delta_{15i} + \delta_{17i}))c(\delta_i + \delta_{3i})s\theta s\theta_{4i}s\phi s\psi\tan\theta_{8i}))$$

$$V_{14i} = c\theta_{8i}^2((x_{16i}s\delta_{17i} + x_{14i}s(\delta_{15i} + \delta_{17i}))(c\theta c\theta_{4i}c\psi s(\delta_i + \delta_{3i})s\delta_{6i}s\phi - s\delta_{6i}s\theta s\theta_{4i}s\phi + c\delta_{6i}(-(c\theta c(\delta_i + \delta_{3i} - \psi)s\phi) + c\phi s(\delta_i + \delta_{3i} - \psi)) + c\theta_{4i}c\phi s(\delta_i + \delta_{3i})s\delta_{6i}s\psi + c(\delta_i + \delta_{3i})c\theta_{4i}s\delta_{6i}(c\phi c\psi - c\theta s\phi s\psi) - c\phi c(\delta_i + \delta_{3i} - \psi)s\theta_{4i}\tan\theta_{8i} - c\theta_{4i}s\theta s\phi\tan\theta_{8i} - c\theta s\theta_{4i}s\phi s(\delta_i + \delta_{3i} - \psi)\tan\theta_{8i}) - x_{16i}c\delta_{17i}(c\delta_{6i}(c\theta c\phi c(\delta_i + \delta_{3i} - \psi) + s\phi s(\delta_i + \delta_{3i} - \psi)) + c(\delta_i + \delta_{3i} - \psi)s\phi(c\theta_{4i}s\delta_{6i} - s\theta_{4i}\tan\theta_{8i}) + c\phi(s\delta_{6i}s\theta s\theta_{4i} - c\theta c\theta_{4i}s\delta_{6i}s(\delta_i + \delta_{3i} - \psi) + c\theta_{4i}s\theta\tan\theta_{8i} + c\theta s\theta_{4i}s(\delta_i + \delta_{3i} - \psi)\tan\theta_{8i})) - x_{14i}c(\delta_{15i} + \delta_{17i})(c\delta_{6i}(c\theta c\phi c(\delta_i + \delta_{3i} - \psi) + s\phi s(\delta_i + \delta_{3i} - \psi)) + c(\delta_i + \delta_{3i} - \psi)s\phi(c\theta_{4i}s\delta_{6i} - s\theta_{4i}\tan\theta_{8i}) + c\phi(s\delta_{6i}s\theta s\theta_{4i} - c\theta c\theta_{4i}s\delta_{6i}s(\delta_i + \delta_{3i} - \psi) + c\theta_{4i}s\theta\tan\theta_{8i} + c\theta s\theta_{4i}s(\delta_i + \delta_{3i} - \psi)\tan\theta_{8i})))$$

$$V_{15i} = c\theta_{8i}^2(z_p c\theta_{4i}s\delta_{6i} + c\theta_{4i}c\phi(x_{16i}s\delta_{17i} + x_{14i}s(\delta_{15i} + \delta_{17i})))s\delta_{6i}s\theta - x_{2i}c\delta_{3i}s\delta_{6i}s\theta_{4i} + x_p c(\delta_i + \delta_{3i})s\delta_{6i}s\theta_{4i} - (x_{16i}c\delta_{17i} + x_{14i}c(\delta_{15i} + \delta_{17i}))c\phi c(\delta_i + \delta_{3i} - \psi)s\delta_{6i}s\theta_{4i} + y_p s(\delta_i + \delta_{3i})s\delta_{6i}s\theta_{4i} - (x_{16i}c\delta_{17i} + x_{14i}c(\delta_{15i} + \delta_{17i}))c\theta_{4i}s\delta_{6i}s\theta s\phi - (x_{16i}c\delta_{17i} + x_{14i}c(\delta_{15i} + \delta_{17i}))c\theta s\delta_{6i}s\theta_{4i}s\phi s(\delta_i + \delta_{3i} - \psi) - c(\delta_i + \delta_{3i})(x_{16i}s\delta_{17i} + x_{14i}s(\delta_{15i} + \delta_{17i}))s\delta_{6i}s\theta_{4i}(c\psi s\phi + c\theta c\phi s\psi) + (x_{16i}s\delta_{17i} + x_{14i}s(\delta_{15i} + \delta_{17i}))s(\delta_i + \delta_{3i})s\delta_{6i}s\theta_{4i}(c\theta c\phi c\psi - s\phi s\psi) - x_{2i}c\delta_{3i}c\theta_{4i}$$

$$\begin{aligned} & \tan \theta_{8i} + x_p c(\delta_{1i} + \delta_{3i}) c\theta_{4i} \tan \theta_{8i} + y_p c\theta_{4i} s(\delta_{1i} + \delta_{3i}) \tan \theta_{8i} - z_p s\theta_{4i} \tan \theta_{8i} - c\phi(x_{16i} s\delta_{17i} + x_{14i} \\ & s(\delta_{15i} + \delta_{17i})) s\theta s\theta_{4i} \tan \theta_{8i} + (x_{16i} c\delta_{17i} + x_{14i} c(\delta_{15i} + \delta_{17i})) s\theta s\theta_{4i} s\phi \tan \theta_{8i} + c\theta_{4i} (x_{16i} s\delta_{17i} + \\ & x_{14i} s(\delta_{15i} + \delta_{17i})) (-c(\delta_{1i} + \delta_{3i}) s\phi) + c\theta c\phi s(\delta_{1i} + \delta_{3i} - \psi)) \tan \theta_{8i} - (x_{16i} c\delta_{17i} + x_{14i} c(\delta_{15i} + \\ & \delta_{17i})) c\theta_{4i} s(\delta_{1i} + \delta_{3i}) (c\theta c\psi s\phi + c\phi s\psi) \tan \theta_{8i} - (x_{16i} c\delta_{17i} + x_{14i} c(\delta_{15i} + \delta_{17i})) c(\delta_{1i} + \delta_{3i}) c\theta_{4i} \\ & (c\phi c\psi - c\theta s\phi s\psi) \tan \theta_{8i} \end{aligned}$$

Coefficientes de la ecuación (2.50):

$$V_{16i} = -a_{14i}$$

$$V_{17i} = c\theta_{9i}^2 \sec \theta_{8i} (-c\theta_{8i} s(\delta_{1i} + \delta_{3i}) s\delta_{6i} \tan \theta_{9i}) + c(\delta_{1i} + \delta_{3i}) (s\theta_{4i} + c\delta_{6i} c\theta_{4i} c\theta_{8i} \tan \theta_{9i})$$

$$V_{18i} = c\theta_{9i}^2 \sec \theta_{8i} (c(\delta_{1i} + \delta_{3i}) c\theta_{8i} s\delta_{6i} \tan \theta_{9i} + s(\delta_{1i} + \delta_{3i}) (s\theta_{4i} + c\delta_{6i} c\theta_{4i} c\theta_{8i} \tan \theta_{9i}))$$

$$V_{19i} = c\theta_{9i}^2 \sec \theta_{8i} (c\theta_{4i} - c\delta_{6i} c\theta_{8i} s\theta_{4i} \tan \theta_{9i})$$

$$\begin{aligned} V_{20i} = & c\theta_{9i}^2 \sec \theta_{8i} (-c\theta c\phi c(\delta_{1i} + \delta_{3i} - \psi) (x_{16i} s\delta_{17i} + \\ & x_{14i} s(\delta_{15i} + \delta_{17i})) s\theta_{4i}) - (x_{16i} c\delta_{17i} + x_{14i} c(\delta_{15i} + \delta_{17i})) c\phi c\psi s(\delta_{1i} + \delta_{3i}) s\theta_{4i} + (x_{16i} c\delta_{17i} + x_{14i} \\ & c(\delta_{15i} + \delta_{17i})) c(\delta_{1i} + \delta_{3i}) c\theta c\psi s\theta_{4i} s\phi - (x_{16i} s\delta_{17i} + x_{14i} s(\delta_{15i} + \delta_{17i})) s\theta_{4i} s\phi s(\delta_{1i} + \delta_{3i} - \psi) + \\ & (x_{16i} c\delta_{17i} + x_{14i} c(\delta_{15i} + \delta_{17i})) c(\delta_{1i} + \delta_{3i}) c\phi s\theta_{4i} s\psi + (x_{16i} c\delta_{17i} + x_{14i} c(\delta_{15i} + \delta_{17i})) c\theta s(\delta_{1i} + \delta_{3i}) \\ & s\theta_{4i} s\phi s\psi - c\delta_{6i} c\theta c\theta_{4i} c\theta_{8i} c\phi c(\delta_{1i} + \delta_{3i} - \psi) (x_{16i} s\delta_{17i} + x_{14i} s(\delta_{15i} + \delta_{17i})) \tan \theta_{9i} + c\theta c\theta_{8i} c\phi c\psi \\ & (x_{16i} s\delta_{17i} + x_{14i} s(\delta_{15i} + \delta_{17i})) s(\delta_{1i} + \delta_{3i}) s\delta_{6i} \tan \theta_{9i} - (x_{16i} c\delta_{17i} + x_{14i} c(\delta_{15i} + \delta_{17i})) c\theta_{8i} c\phi c\psi \\ & (c\delta_{6i} c\theta_{4i} s(\delta_{1i} + \delta_{3i}) + c(\delta_{1i} + \delta_{3i}) s\delta_{6i}) \tan \theta_{9i} - c(\delta_{1i} + \delta_{3i}) c\theta_{8i} c\psi (x_{16i} s\delta_{17i} + x_{14i} s(\delta_{15i} + \delta_{17i})) \\ & s\delta_{6i} s\phi \tan \theta_{9i} + (x_{16i} c\delta_{17i} + x_{14i} c(\delta_{15i} + \delta_{17i})) c\theta c\theta_{8i} c\psi (c(\delta_{1i} + \delta_{3i}) c\delta_{6i} c\theta_{4i} - s(\delta_{1i} + \delta_{3i}) s\delta_{6i}) s\phi \\ & \tan \theta_{9i} - c\delta_{6i} c\theta_{4i} c\theta_{8i} (x_{16i} s\delta_{17i} + x_{14i} s(\delta_{15i} + \delta_{17i})) s\phi s(\delta_{1i} + \delta_{3i} - \psi) \tan \theta_{9i} - c(\delta_{1i} + \delta_{3i}) c\theta c\theta_{8i} c\phi \\ & (x_{16i} s\delta_{17i} + x_{14i} s(\delta_{15i} + \delta_{17i})) s\delta_{6i} s\psi \tan \theta_{9i} + (x_{16i} c\delta_{17i} + x_{14i} c(\delta_{15i} + \delta_{17i})) c\theta_{8i} c\phi (c(\delta_{1i} + \delta_{3i}) c\delta_{6i} \\ & c\theta_{4i} - s(\delta_{1i} + \delta_{3i}) s\delta_{6i}) s\psi \tan \theta_{9i} - c\theta_{8i} (x_{16i} s\delta_{17i} + x_{14i} s(\delta_{15i} + \delta_{17i})) s(\delta_{1i} + \delta_{3i}) s\delta_{6i} s\phi s\psi \tan \theta_{9i} \\ & + (x_{16i} c\delta_{17i} + x_{14i} c(\delta_{15i} + \delta_{17i})) c\theta c\theta_{8i} (c\delta_{6i} c\theta_{4i} s(\delta_{1i} + \delta_{3i}) + c(\delta_{1i} + \delta_{3i}) s\delta_{6i}) s\phi s\psi \tan \theta_{9i} \end{aligned}$$

$$\begin{aligned} V_{21i} = & c\theta_{9i}^2 \sec \theta_{8i} (c\theta c\theta_{4i} c\phi (x_{16i} s\delta_{17i} + x_{14i} s(\delta_{15i} + \delta_{17i})) - \\ & (x_{16i} c\delta_{17i} + x_{14i} c(\delta_{15i} + \delta_{17i})) c\theta c\theta_{4i} s\phi + (x_{16i} c\delta_{17i} + x_{14i} c(\delta_{15i} + \delta_{17i})) c\psi s(\delta_{1i} + \delta_{3i}) s\theta s\theta_{4i} s\phi - \\ & c\phi (x_{16i} s\delta_{17i} + x_{14i} s(\delta_{15i} + \delta_{17i})) s\theta s\theta_{4i} s(\delta_{1i} + \delta_{3i} - \psi) - (x_{16i} c\delta_{17i} + x_{14i} c(\delta_{15i} + \delta_{17i})) c(\delta_{1i} + \delta_{3i}) \\ & s\theta s\theta_{4i} s\phi s\psi - c(\delta_{1i} + \delta_{3i}) c\theta_{8i} c\phi c\psi (x_{16i} s\delta_{17i} + x_{14i} s(\delta_{15i} + \delta_{17i})) s\delta_{6i} s\theta \tan \theta_{9i} - c\delta_{6i} c\theta c\theta_{8i} c\phi \\ & (x_{16i} s\delta_{17i} + x_{14i} s(\delta_{15i} + \delta_{17i})) s\theta_{4i} \tan \theta_{9i} + (x_{16i} c\delta_{17i} + x_{14i} c(\delta_{15i} + \delta_{17i})) c\theta_{8i} c\psi (c\delta_{6i} c\theta_{4i} \\ & s(\delta_{1i} + \delta_{3i}) + c(\delta_{1i} + \delta_{3i}) s\delta_{6i}) s\theta s\phi \tan \theta_{9i} + (x_{16i} c\delta_{17i} + x_{14i} c(\delta_{15i} + \delta_{17i})) c\delta_{6i} c\theta c\theta_{8i} s\theta_{4i} s\phi \\ & \tan \theta_{9i} - c\delta_{6i} c\theta_{4i} c\theta_{8i} c\phi (x_{16i} s\delta_{17i} + x_{14i} s(\delta_{15i} + \delta_{17i})) s\theta s(\delta_{1i} + \delta_{3i} - \psi) \tan \theta_{9i} - c\theta_{8i} c\phi (x_{16i} s\delta_{17i} + \\ & x_{14i} s(\delta_{15i} + \delta_{17i})) s(\delta_{1i} + \delta_{3i}) s\delta_{6i} s\theta s\psi \tan \theta_{9i} - (x_{16i} c\delta_{17i} + x_{14i} c(\delta_{15i} + \delta_{17i})) c\theta_{8i} (c(\delta_{1i} + \delta_{3i}) \\ & c\delta_{6i} c\theta_{4i} - s(\delta_{1i} + \delta_{3i}) s\delta_{6i}) s\theta s\phi s\psi \tan \theta_{9i} \end{aligned}$$

$$\begin{aligned} V_{22i} = & c\theta_{9i}^2 \sec \theta_{8i} (-((x_{16i} s\delta_{17i} + x_{14i} s(\delta_{15i} + \delta_{17i})) (c\phi \\ & (-c\theta_{8i} s\delta_{6i} s(\delta_{1i} + \delta_{3i} - \psi) \tan \theta_{9i}) + c(\delta_{1i} + \delta_{3i} - \psi) (s\theta_{4i} + c\delta_{6i} c\theta_{4i} c\theta_{8i} \tan \theta_{9i})) + s\phi (c\theta s\theta_{4i} \\ & s(\delta_{1i} + \delta_{3i} - \psi) + c\theta c\theta_{8i} c(\delta_{1i} + \delta_{3i} - \psi) s\delta_{6i} \tan \theta_{9i} - c\delta_{6i} c\theta_{8i} s\theta s\theta_{4i} \tan \theta_{9i} + c\theta_{4i} (s\theta + c\delta_{6i} c\theta c\theta_{8i} \\ & s(\delta_{1i} + \delta_{3i} - \psi) \tan \theta_{9i}))) + x_{16i} c\delta_{17i} (c(\delta_{1i} + \delta_{3i}) c\psi s\theta_{4i} s\phi + s(\delta_{1i} + \delta_{3i}) s\theta_{4i} s\phi s\psi + c\delta_{6i} c\theta_{8i} c\phi \end{aligned}$$

$$\begin{aligned}
 & s\theta s\theta_{4i} \tan \theta_{9i} - c\theta_{8i} c\psi s(\delta_{1i} + \delta_{3i}) s\delta_{6i} s\phi \tan \theta_{9i} + c(\delta_{1i} + \delta_{3i}) c\theta_{8i} s\delta_{6i} s\phi s\psi \tan \theta_{9i} - c\theta c\phi (c\psi \\
 & s(\delta_{1i} + \delta_{3i}) s\theta_{4i} - c(\delta_{1i} + \delta_{3i}) s\theta_{4i} s\psi + c(\delta_{1i} + \delta_{3i}) c\theta_{8i} c\psi s\delta_{6i} \tan \theta_{9i} + c\theta_{8i} s(\delta_{1i} + \delta_{3i}) s\delta_{6i} s\psi \\
 & \tan \theta_{9i}) - c\theta_{4i} (-c\delta_{6i} c\theta_{8i} c(\delta_{1i} + \delta_{3i} - \psi) s\phi \tan \theta_{9i}) + c\phi (s\theta + c\delta_{6i} c\theta c\theta_{8i} s(\delta_{1i} + \delta_{3i} - \psi) \\
 & \tan \theta_{9i})) + x_{14i} c(\delta_{15i} + \delta_{17i}) (c(\delta_{1i} + \delta_{3i}) c\psi s\theta_{4i} s\phi + s(\delta_{1i} + \delta_{3i}) s\theta_{4i} s\phi s\psi + c\delta_{6i} c\theta_{8i} c\phi s\theta s\theta_{4i} \\
 & \tan \theta_{9i} - c\theta_{8i} c\psi s(\delta_{1i} + \delta_{3i}) s\delta_{6i} s\phi \tan \theta_{9i} + c(\delta_{1i} + \delta_{3i}) c\theta_{8i} s\delta_{6i} s\phi s\psi \tan \theta_{9i} - c\theta c\phi (c\psi s(\delta_{1i} + \delta_{3i}) \\
 & s\theta_{4i} - c(\delta_{1i} + \delta_{3i}) s\theta_{4i} s\psi + c(\delta_{1i} + \delta_{3i}) c\theta_{8i} c\psi s\delta_{6i} \tan \theta_{9i} + c\theta_{8i} s(\delta_{1i} + \delta_{3i}) s\delta_{6i} s\psi \tan \theta_{9i}) - \\
 & c\theta_{4i} (-c\delta_{6i} c\theta_{8i} c(\delta_{1i} + \delta_{3i} - \psi) s\phi \tan \theta_{9i}) + c\phi (s\theta + c\delta_{6i} c\theta c\theta_{8i} s(\delta_{1i} + \delta_{3i} - \psi) \tan \theta_{9i}))) \\
 V_{23i} = & c\theta_{9i}^2 \text{Sec}\theta_{8i} (-x_{2i} c\delta_{3i} c\theta_{4i}) + x_p c(\delta_{1i} + \delta_{3i}) c\theta_{4i} + \\
 & y_p c\theta_{4i} s(\delta_{1i} + \delta_{3i}) - z_p s\theta_{4i} - c\phi (x_{16i} s\delta_{17i} + x_{14i} s(\delta_{15i} + \delta_{17i})) s\theta s\theta_{4i} + (x_{16i} c\delta_{17i} + x_{14i} c(\delta_{15i} + \delta_{17i})) \\
 & s\theta s\theta_{4i} s\phi + c\theta_{4i} (x_{16i} s\delta_{17i} + x_{14i} s(\delta_{15i} + \delta_{17i})) (-c(\delta_{1i} + \delta_{3i} - \psi) s\phi) + c\theta c\phi s(\delta_{1i} + \delta_{3i} - \psi) - (x_{16i} \\
 & c\delta_{17i} + x_{14i} c(\delta_{15i} + \delta_{17i})) c\theta_{4i} s(\delta_{1i} + \delta_{3i}) (c\theta c\psi s\phi + c\phi s\psi) - (x_{16i} c\delta_{17i} + x_{14i} c(\delta_{15i} + \delta_{17i})) \\
 & c(\delta_{1i} + \delta_{3i}) c\theta_{4i} (c\phi c\psi - c\theta s\phi s\psi) - z_p c\delta_{6i} c\theta_{4i} c\theta_{8i} \tan \theta_{9i} - c\delta_{6i} c\theta_{4i} c\theta_{8i} c\phi (x_{16i} s\delta_{17i} + x_{14i} s(\delta_{15i} + \\
 & \delta_{17i})) s\theta \tan \theta_{9i} + x_{2i} c\delta_{3i} c\delta_{6i} c\theta_{8i} s\theta_{4i} \tan \theta_{9i} - x_p c(\delta_{1i} + \delta_{3i}) c\delta_{6i} c\theta_{8i} s\theta_{4i} \tan \theta_{9i} - y_p c\delta_{6i} c\theta_{8i} \\
 & s(\delta_{1i} + \delta_{3i}) s\theta_{4i} \tan \theta_{9i} + (x_{16i} c\delta_{17i} + x_{14i} c(\delta_{15i} + \delta_{17i})) c\delta_{6i} c\theta_{4i} c\theta_{8i} s\theta s\phi \tan \theta_{9i} + c\delta_{6i} c\theta_{8i} c(\delta_{1i} + \\
 & \delta_{3i} - \psi) (x_{16i} s\delta_{17i} + x_{14i} s(\delta_{15i} + \delta_{17i})) s\theta_{4i} s\phi \tan \theta_{9i} - c\delta_{6i} c\theta c\theta_{8i} c\phi (x_{16i} s\delta_{17i} + x_{14i} s(\delta_{15i} + \delta_{17i})) s\theta_{4i} \\
 & s(\delta_{1i} + \delta_{3i} - \psi) \tan \theta_{9i} + (x_{16i} c\delta_{17i} + x_{14i} c(\delta_{15i} + \delta_{17i})) c\delta_{6i} c\theta_{8i} s(\delta_{1i} + \delta_{3i}) s\theta_{4i} (c\theta c\psi s\phi + c\phi s\psi) \\
 & \tan \theta_{9i} + (x_{16i} c\delta_{17i} + x_{14i} c(\delta_{15i} + \delta_{17i})) c(\delta_{1i} + \delta_{3i}) c\delta_{6i} c\theta_{8i} s\theta_{4i} (c\phi c\psi - c\theta s\phi s\psi) \tan \theta_{9i}) \\
 V_{24i} = & -(c\theta_{9i} s\theta_{9i} (-x_{7i} - x_{5i} c\delta_{6i} - x_{2i} c\delta_{3i} c\delta_{6i} c\theta_{4i} + x_{2i} \\
 & s\delta_{3i} s\delta_{6i} + y_p (c\delta_{6i} c\theta_{4i} s(\delta_{1i} + \delta_{3i}) + c(\delta_{1i} + \delta_{3i}) s\delta_{6i}) + x_p (c(\delta_{1i} + \delta_{3i}) c\delta_{6i} c\theta_{4i} - s(\delta_{1i} + \delta_{3i}) s\delta_{6i}) - \\
 & z_p c\delta_{6i} s\theta_{4i} + (x_{16i} s\delta_{17i} + x_{14i} s(\delta_{15i} + \delta_{17i})) (-c\delta_{6i} (c\phi s\theta s\theta_{4i} + c\theta_{4i} c(\delta_{1i} + \delta_{3i} - \psi) s\phi - c\theta c\theta_{4i} c\phi \\
 & s(\delta_{1i} + \delta_{3i} - \psi))) + s(\delta_{1i} + \delta_{3i}) s\delta_{6i} (c\psi s\phi + c\theta c\phi s\psi) + c(\delta_{1i} + \delta_{3i}) s\delta_{6i} (c\theta c\phi c\psi - s\phi s\psi)) + \\
 & (-x_{16i} c\delta_{17i}) - x_{14i} c(\delta_{15i} + \delta_{17i})) (-c\delta_{6i} s\theta s\theta_{4i} s\phi) + (c\delta_{6i} c\theta_{4i} s(\delta_{1i} + \delta_{3i}) + c(\delta_{1i} + \delta_{3i}) s\delta_{6i}) (c\theta c\psi \\
 & s\phi + c\phi s\psi) + (c(\delta_{1i} + \delta_{3i}) c\delta_{6i} c\theta_{4i} - s(\delta_{1i} + \delta_{3i}) s\delta_{6i}) (c\phi c\psi - c\theta s\phi s\psi)) \tan \theta_{8i})
 \end{aligned}$$

Coefficientes de la ecuación (2.55):

$$V_{25i} = -c_{23i}$$

$$V_{26i} = 0$$

$$V_{27i} = 0$$

$$V_{28i} = 0$$

$$\begin{aligned}
 V_{29i} = & c\theta_{11i}^2 s\theta (-s(\delta_{1i} + \delta_{3i}) (c\theta_{9i} (c\psi s\delta_{6i} - c\delta_{6i} c\theta_{4i} s\psi) + c\delta_{6i} c\psi (s\theta_{8i} s\theta_{9i} + c\theta_{8i} \tan \theta_{11i}) + s\psi (c\theta_{8i} \\
 & s\theta_{4i} s\theta_{9i} + c\theta_{4i} s\delta_{6i} s\theta_{8i} s\theta_{9i} + c\theta_{4i} c\theta_{8i} s\delta_{6i} \tan \theta_{11i} - s\theta_{4i} s\theta_{8i} \tan \theta_{11i}))) + c(\delta_{1i} + \delta_{3i}) (-c\theta_{4i} c\psi s\delta_{6i} \\
 & s\theta_{8i} s\theta_{9i}) + c\theta_{9i} s\delta_{6i} s\psi + c\psi s\theta_{4i} s\theta_{8i} \tan \theta_{11i} - c\theta_{8i} c\psi (s\theta_{4i} s\theta_{9i} + c\theta_{4i} s\delta_{6i} \tan \theta_{11i}) + c\delta_{6i} (c\theta_{4i} c\theta_{9i} \\
 & c\psi + s\psi (s\theta_{8i} s\theta_{9i} + c\theta_{8i} \tan \theta_{11i})))
 \end{aligned}$$

$$\begin{aligned}
 V_{30i} = & c\theta_{11i}^2 (c\theta_{4i} c\theta_{8i} s\theta s\theta_{9i} + c\theta c\theta_{8i} c\psi s(\delta_{1i} + \delta_{3i}) s\theta_{4i} s\theta_{9i} + c\theta c\theta_{4i} c\psi s(\delta_{1i} + \delta_{3i}) s\delta_{6i} s\theta_{8i} s\theta_{9i} - s\delta_{6i} s\theta \\
 & s\theta_{4i} s\theta_{8i} s\theta_{9i} - c\theta c\theta_{9i} s(\delta_{1i} + \delta_{3i}) s\delta_{6i} s\psi + c\theta c\theta_{4i} c\theta_{8i} c\psi s(\delta_{1i} + \delta_{3i}) s\delta_{6i} \tan \theta_{11i} - c\theta_{8i} s\delta_{6i} s\theta s\theta_{4i} \\
 & \tan \theta_{11i} - c\theta_{4i} s\theta s\theta_{8i} \tan \theta_{11i} - c\theta c\psi s(\delta_{1i} + \delta_{3i}) s\theta_{4i} s\theta_{8i} \tan \theta_{11i} + c\delta_{6i} (c\theta_{9i} (s\theta s\theta_{4i} - c\theta c\theta_{4i} \\
 & s(\delta_{1i} + \delta_{3i} - \psi)) - c\theta c(\delta_{1i} + \delta_{3i} - \psi) (s\theta_{8i} s\theta_{9i} + c\theta_{8i} \tan \theta_{11i})) - c(\delta_{1i} + \delta_{3i}) c\theta (c\theta_{9i} c\psi s\delta_{6i} + s\psi
 \end{aligned}$$

$$\begin{aligned}
& (c\theta_{8i}s\theta_{4i}s\theta_{9i} + c\theta_{4i}s\delta_{6i}s\theta_{8i}s\theta_{9i} + c\theta_{4i}c\theta_{8i}s\delta_{6i}\tan\theta_{11i} - s\theta_{4i}s\theta_{8i}\tan\theta_{11i})) \\
V_{31i} &= 0 \\
V_{32i} &= c\theta_{11i}^2(c\delta_{6i}c\theta_{9i}(-c\theta c\theta_{4i}) + s\theta s\theta_{4i}s(\delta_{1i} + \delta_{3i} - \psi)) + s\theta_{4i}(-s\delta_{6i}s\theta s(\delta_{1i} + \delta_{3i} - \psi)(s\theta_{8i}s\theta_{9i} + c\theta_{8i} \\
& \tan\theta_{11i})) + c\theta(c\theta_{8i}s\theta_{9i} - s\theta_{8i}\tan\theta_{11i})) + c\theta_{4i}(c\theta_{8i}(c\psi s(\delta_{1i} + \delta_{3i})s\theta s\theta_{9i} - c(\delta_{1i} + \delta_{3i})s\theta s\theta_{9i}s\psi + \\
& c\theta s\delta_{6i}\tan\theta_{11i}) + s\theta_{8i}(c\theta s\delta_{6i}s\theta_{9i} - s\theta s(\delta_{1i} + \delta_{3i} - \psi)\tan\theta_{11i})) \\
V_{33i} &= c\theta_{11i}^2(c\theta c\theta_{8i}s\delta_{6i}s\theta_{4i}s\theta_{9i} - c\psi s(\delta_{1i} + \delta_{3i})s\theta s\theta_{4i}s\theta_{8i}s\theta_{9i} - c\delta_{6i}c\theta_{8i}s(\delta_{1i} + \delta_{3i})s\theta s\theta_{9i}s\psi - c\theta_{8i}c\psi \\
& s(\delta_{1i} + \delta_{3i})s\theta s\theta_{4i}\tan\theta_{11i} - c\theta s\delta_{6i}s\theta_{4i}s\theta_{8i}\tan\theta_{11i} + c\delta_{6i}s(\delta_{1i} + \delta_{3i})s\theta s\theta_{8i}s\psi\tan\theta_{11i} + c\theta_{4i}(c\theta_{8i} \\
& c\psi s(\delta_{1i} + \delta_{3i})s\delta_{6i}s\theta s\theta_{9i} + c\theta s\theta_{8i}s\theta_{9i} + c\theta c\theta_{8i}\tan\theta_{11i} - c\psi s(\delta_{1i} + \delta_{3i})s\delta_{6i}s\theta s\theta_{8i}\tan\theta_{11i}) + \\
& c(\delta_{1i} + \delta_{3i})s\theta(c\delta_{6i}c\psi(-c\theta_{8i}s\theta_{9i}) + s\theta_{8i}\tan\theta_{11i}) + s\psi(s\theta_{4i}(s\theta_{8i}s\theta_{9i} + c\theta_{8i}\tan\theta_{11i}) + c\theta_{4i} \\
& s\delta_{6i}(-c\theta_{8i}s\theta_{9i}) + s\theta_{8i}\tan\theta_{11i})) \\
V_{34i} &= c\theta_{11i}^2(c\theta(-c\theta_{4i}c\theta_{8i}c\theta_{9i}) + s\theta_{4i}(c\theta_{9i}s\delta_{6i}s\theta_{8i} + c\delta_{6i}s\theta_{9i})) + s\theta(c\theta_{4i}c\psi s(\delta_{1i} + \delta_{3i})(c\theta_{9i}s\delta_{6i}s\theta_{8i} + \\
& c\delta_{6i}s\theta_{9i}) + c\theta_{8i}c\theta_{9i}s\theta_{4i}s(\delta_{1i} + \delta_{3i} - \psi) - c\delta_{6i}c\theta_{9i}s(\delta_{1i} + \delta_{3i})s\theta_{8i}s\psi + s(\delta_{1i} + \delta_{3i})s\delta_{6i}s\theta_{9i}s\psi - \\
& c(\delta_{1i} + \delta_{3i})(s\delta_{6i}(-c\psi s\theta_{9i}) + c\theta_{4i}c\theta_{9i}s\theta_{8i}s\psi) + c\delta_{6i}(c\theta_{9i}c\psi s\theta_{8i} + c\theta_{4i}s\theta_{9i}s\psi)))
\end{aligned}$$

Coefficientes de la ecuación (2.60):

$$V_{35i} = c_{32i}$$

$$V_{36i} = 0$$

$$V_{37i} = 0$$

$$V_{38i} = 0$$

$$\begin{aligned}
V_{39i} &= c\theta_{13i}^2(c(\delta_{1i} + \delta_{3i})\sec\theta_{13i}(c\theta s\delta_{15i} + \delta_{17i} + \theta_{13i} - \phi(c\theta_{8i}c\theta_{9i}c\psi s\theta_{4i} + c\theta_{4i}c\psi(c\theta_{9i}s\delta_{6i}s\theta_{8i} + c\delta_{6i} \\
& s\theta_{9i})) + (-c\delta_{6i}c\theta_{9i}s\theta_{8i}) + s\delta_{6i}s\theta_{9i})s\psi) - c\delta_{15i} + \delta_{17i} + \theta_{13i} - \phi(-c\psi s\delta_{6i}s\theta_{9i}) + c\theta_{9i}(c\theta_{8i}s\theta_{4i} + c\theta_{4i} \\
& s\delta_{6i}s\theta_{8i})s\psi + c\delta_{6i}(c\theta_{9i}c\psi s\theta_{8i} + c\theta_{4i}s\theta_{9i}s\psi)) + s(\delta_{1i} + \delta_{3i})(s(\delta_{15i} + \delta_{17i})(c\theta_{8i}c\theta_{9i}c\psi s\theta_{4i} + \\
& s\delta_{6i}c\theta_{4i}c\theta_{9i}c\psi s\theta_{8i} + s\theta_{9i}s\psi))(s\phi - c\phi\tan\theta_{13i}) - c\theta(c\psi s\delta_{6i}s\theta_{9i} - c\theta_{9i}(c\theta_{8i}s\theta_{4i} + c\theta_{4i}s\delta_{6i}s\theta_{8i}) \\
& s\psi)(c\phi + s\phi\tan\theta_{13i}) + c\delta_{6i}((c\theta_{4i}c\psi s\theta_{9i} - c\theta_{9i}s\theta_{8i}s\psi)(s\phi - c\phi\tan\theta_{13i}) + c\theta(c\theta_{9i}c\psi s\theta_{8i} + c\theta_{4i} \\
& s\theta_{9i}s\psi)(c\phi + s\phi\tan\theta_{13i})) + c(\delta_{15i} + \delta_{17i})((c\delta_{6i}c\theta_{9i}s\theta_{8i} - s\delta_{6i}s\theta_{9i})(c\theta c\psi \sec\theta_{13i}s\theta_{13i} - \phi - s\psi \\
& (c\phi + s\phi\tan\theta_{13i})) + c\theta_{8i}c\theta_{9i}s\theta_{4i}(s\phi(-c\theta s\psi) + c\psi\tan\theta_{13i}) + c\phi(c\psi + c\theta s\psi\tan\theta_{13i})) + \\
& c\theta_{4i}(c\theta_{9i}s\delta_{6i}s\theta_{8i} + c\delta_{6i}s\theta_{9i})(s\phi(-c\theta s\psi) + c\psi\tan\theta_{13i}) + c\phi(c\psi + c\theta s\psi\tan\theta_{13i})))) \\
V_{40i} &= -(c\theta_{13i}s\delta_{15i} + \delta_{17i} + \theta_{13i} - \phi(c\theta(c\theta_{4i}c\theta_{8i}c\theta_{9i} - s\theta_{4i}(c\theta_{9i}s\delta_{6i}s\theta_{8i} + c\delta_{6i}s\theta_{9i})) + s\theta(-c\theta_{4i}c\psi s(\delta_{1i} + \\
& \delta_{3i})(c\theta_{9i}s\delta_{6i}s\theta_{8i} + c\delta_{6i}s\theta_{9i})) - c\theta_{8i}c\theta_{9i}s\theta_{4i}s(\delta_{1i} + \delta_{3i} - \psi) + c\delta_{6i}c\theta_{9i}s(\delta_{1i} + \delta_{3i})s\theta_{8i}s\psi - s(\delta_{1i} + \delta_{3i}) \\
& s\delta_{6i}s\theta_{9i}s\psi + c(\delta_{1i} + \delta_{3i})(s\delta_{6i}(-c\psi s\theta_{9i}) + c\theta_{4i}c\theta_{9i}s\theta_{8i}s\psi) + c\delta_{6i}(c\theta_{9i}c\psi s\theta_{8i} + c\theta_{4i}s\theta_{9i}s\psi)))) \\
V_{41i} &= c\theta_{13i}^2(c(\delta_{15i} + \delta_{17i})c\phi s\theta(c\theta_{4i}c\theta_{8i}c\theta_{9i} - s\theta_{4i}(c\theta_{9i}s\delta_{6i}s\theta_{8i} + c\delta_{6i}s\theta_{9i})) + c\phi c\psi s(\delta_{15i} + \delta_{17i})(s(\delta_{1i} + \\
& \delta_{3i})(c\delta_{6i}c\theta_{9i}s\theta_{8i} - s\delta_{6i}s\theta_{9i}) + c(\delta_{1i} + \delta_{3i})(c\theta_{8i}c\theta_{9i}s\theta_{4i} + c\theta_{4i}(c\theta_{9i}s\delta_{6i}s\theta_{8i} + c\delta_{6i}s\theta_{9i})))) + c(\delta_{15i} + \\
& \delta_{17i})c\theta c\phi c\psi(c(\delta_{1i} + \delta_{3i})(-c\delta_{6i}c\theta_{9i}s\theta_{8i}) + s\delta_{6i}s\theta_{9i}) + s(\delta_{1i} + \delta_{3i})(c\theta_{8i}c\theta_{9i}s\theta_{4i} + c\theta_{4i}(c\theta_{9i}s\delta_{6i} \\
& s\theta_{8i} + c\delta_{6i}s\theta_{9i}))) + s(\delta_{15i} + \delta_{17i})s\theta(c\theta_{4i}c\theta_{8i}c\theta_{9i} - s\theta_{4i}(c\theta_{9i}s\delta_{6i}s\theta_{8i} + c\delta_{6i}s\theta_{9i}))s\phi - c(\delta_{15i} + \delta_{17i}) \\
& c\psi(s(\delta_{1i} + \delta_{3i})(c\delta_{6i}c\theta_{9i}s\theta_{8i} - s\delta_{6i}s\theta_{9i}) + c(\delta_{1i} + \delta_{3i})(c\theta_{8i}c\theta_{9i}s\theta_{4i} + c\theta_{4i}(c\theta_{9i}s\delta_{6i}s\theta_{8i} + c\delta_{6i}s\theta_{9i}))) \\
& s\phi + c\theta c\psi s(\delta_{15i} + \delta_{17i})(c(\delta_{1i} + \delta_{3i})(-c\delta_{6i}c\theta_{9i}s\theta_{8i}) + s\delta_{6i}s\theta_{9i}) + s(\delta_{1i} + \delta_{3i})(c\theta_{8i}c\theta_{9i}s\theta_{4i} + c\theta_{4i} \\
& (c\theta_{9i}s\delta_{6i}s\theta_{8i} + c\delta_{6i}s\theta_{9i})))s\phi - c(\delta_{15i} + \delta_{17i})c\theta c\phi(s(\delta_{1i} + \delta_{3i})(c\delta_{6i}c\theta_{9i}s\theta_{8i} - s\delta_{6i}s\theta_{9i}) + c(\delta_{1i} + \delta_{3i})
\end{aligned}$$

$$\begin{aligned}
 & (c\theta_{8i}c\theta_{9i}s\theta_{4i}+c\theta_{4i}(c\theta_{9i}s\delta_{6i}s\theta_{8i}+c\delta_{6i}s\theta_{9i}))s\psi+c\phi s(\delta_{15i}+\delta_{17i})(c(\delta_{1i}+\delta_{3i})(-c\delta_{6i}c\theta_{9i}s\theta_{8i})+ \\
 & s\delta_{6i}s\theta_{9i})+s(\delta_{1i}+\delta_{3i})(c\theta_{8i}c\theta_{9i}s\theta_{4i}+c\theta_{4i}(c\theta_{9i}s\delta_{6i}s\theta_{8i}+c\delta_{6i}s\theta_{9i}))s\psi-c\theta s(\delta_{15i}+\delta_{17i})(s(\delta_{1i}+ \\
 & \delta_{3i})(c\delta_{6i}c\theta_{9i}s\theta_{8i}-s\delta_{6i}s\theta_{9i})+c(\delta_{1i}+\delta_{3i})(c\theta_{8i}c\theta_{9i}s\theta_{4i}+c\theta_{4i}(c\theta_{9i}s\delta_{6i}s\theta_{8i}+c\delta_{6i}s\theta_{9i})))s\phi s\psi- \\
 & c(\delta_{15i}+\delta_{17i})(c(\delta_{1i}+\delta_{3i})(-c\delta_{6i}c\theta_{9i}s\theta_{8i})+s\delta_{6i}s\theta_{9i})+s(\delta_{1i}+\delta_{3i})(c\theta_{8i}c\theta_{9i}s\theta_{4i}+c\theta_{4i}(c\theta_{9i}s\delta_{6i} \\
 & s\theta_{8i}+c\delta_{6i}s\theta_{9i})))s\phi s\psi-c\phi s(\delta_{15i}+\delta_{17i})s\theta(c\theta_{4i}c\theta_{8i}c\theta_{9i}-s\theta_{4i}(c\theta_{9i}s\delta_{6i}s\theta_{8i}+c\delta_{6i}s\theta_{9i}))\tan\theta_{13i}+ \\
 & c(\delta_{15i}+\delta_{17i})c\phi c\psi(s(\delta_{1i}+\delta_{3i})(c\delta_{6i}c\theta_{9i}s\theta_{8i}-s\delta_{6i}s\theta_{9i})+c(\delta_{1i}+\delta_{3i})(c\theta_{8i}c\theta_{9i}s\theta_{4i}+c\theta_{4i}(c\theta_{9i}s\delta_{6i} \\
 & s\theta_{8i}+c\delta_{6i}s\theta_{9i})))\tan\theta_{13i}-c\theta c\phi c\psi s(\delta_{15i}+\delta_{17i})(c(\delta_{1i}+\delta_{3i})(-c\delta_{6i}c\theta_{9i}s\theta_{8i})+s\delta_{6i}s\theta_{9i})+s(\delta_{1i}+ \\
 & \delta_{3i})(c\theta_{8i}c\theta_{9i}s\theta_{4i}+c\theta_{4i}(c\theta_{9i}s\delta_{6i}s\theta_{8i}+c\delta_{6i}s\theta_{9i})))\tan\theta_{13i}+c(\delta_{15i}+\delta_{17i})s\theta(c\theta_{4i}c\theta_{8i}c\theta_{9i}-s\theta_{4i} \\
 & (c\theta_{9i}s\delta_{6i}s\theta_{8i}+c\delta_{6i}s\theta_{9i}))s\phi\tan\theta_{13i}+c\psi s(\delta_{15i}+\delta_{17i})(s(\delta_{1i}+\delta_{3i})(c\delta_{6i}c\theta_{9i}s\theta_{8i}-s\delta_{6i}s\theta_{9i})+ \\
 & c(\delta_{1i}+\delta_{3i})(c\theta_{8i}c\theta_{9i}s\theta_{4i}+c\theta_{4i}(c\theta_{9i}s\delta_{6i}s\theta_{8i}+c\delta_{6i}s\theta_{9i})))s\phi\tan\theta_{13i}+c(\delta_{15i}+\delta_{17i})c\theta c\psi(c(\delta_{1i}+ \\
 & \delta_{3i})(-c\delta_{6i}c\theta_{9i}s\theta_{8i})+s\delta_{6i}s\theta_{9i})+s(\delta_{1i}+\delta_{3i})(c\theta_{8i}c\theta_{9i}s\theta_{4i}+c\theta_{4i}(c\theta_{9i}s\delta_{6i}s\theta_{8i}+c\delta_{6i}s\theta_{9i})))s\phi \\
 & \tan\theta_{13i}+c\theta c\phi s(\delta_{15i}+\delta_{17i})(s(\delta_{1i}+\delta_{3i})(c\delta_{6i}c\theta_{9i}s\theta_{8i}-s\delta_{6i}s\theta_{9i})+c(\delta_{1i}+\delta_{3i})(c\theta_{8i}c\theta_{9i}s\theta_{4i}+c\theta_{4i} \\
 & (c\theta_{9i}s\delta_{6i}s\theta_{8i}+c\delta_{6i}s\theta_{9i})))s\psi\tan\theta_{13i}+c(\delta_{15i}+\delta_{17i})c\phi(c(\delta_{1i}+\delta_{3i})(-c\delta_{6i}c\theta_{9i}s\theta_{8i})+s\delta_{6i}s\theta_{9i})+ \\
 & s(\delta_{1i}+\delta_{3i})(c\theta_{8i}c\theta_{9i}s\theta_{4i}+c\theta_{4i}(c\theta_{9i}s\delta_{6i}s\theta_{8i}+c\delta_{6i}s\theta_{9i})))s\psi\tan\theta_{13i}-c(\delta_{15i}+\delta_{17i})c\theta(s(\delta_{1i}+\delta_{3i}) \\
 & (c\delta_{6i}c\theta_{9i}s\theta_{8i}-s\delta_{6i}s\theta_{9i})+c(\delta_{1i}+\delta_{3i})(c\theta_{8i}c\theta_{9i}s\theta_{4i}+c\theta_{4i}(c\theta_{9i}s\delta_{6i}s\theta_{8i}+c\delta_{6i}s\theta_{9i})))s\phi s\psi\tan\theta_{13i}+ \\
 & s(\delta_{15i}+\delta_{17i})(c(\delta_{1i}+\delta_{3i})(-c\delta_{6i}c\theta_{9i}s\theta_{8i})+s\delta_{6i}s\theta_{9i})+s(\delta_{1i}+\delta_{3i})(c\theta_{8i}c\theta_{9i}s\theta_{4i}+c\theta_{4i}(c\theta_{9i}s\delta_{6i} \\
 & s\theta_{8i}+c\delta_{6i}s\theta_{9i})))s\phi s\psi\tan\theta_{13i})
 \end{aligned}$$

$$\begin{aligned}
 V_{42i} = & c\theta_{13i}^2(s(\delta_{15i}+\delta_{17i})(\sec\theta_{13i}(c\theta_{9i}s\delta_{6i}s\theta_{8i}+c\delta_{6i}s\theta_{9i})(c\theta_{4i}c\theta_{13i}-\phi s\theta+s\theta_{4i}(c(\delta_{1i}+\delta_{3i})c\psi s\theta_{13i}- \\
 & \phi+c\theta c\theta_{13i}-\phi s(\delta_{1i}+\delta_{3i}-\psi)+s(\delta_{1i}+\delta_{3i})s\theta_{13i}-\phi s\psi)))+c\theta_{8i}c\theta_{9i}(c(\delta_{1i}+\delta_{3i})c\theta_{4i}c\psi s\phi-c\theta c\theta_{4i} \\
 & c\theta_{13i}-\phi \sec\theta_{13i}s(\delta_{1i}+\delta_{3i}-\psi)+c\theta_{4i}s(\delta_{1i}+\delta_{3i})s\phi s\psi+s\theta s\theta_{4i}s\phi\tan\theta_{13i}+c\phi(s\theta s\theta_{4i}-c\theta_{4i}c(\delta_{1i}+ \\
 & \delta_{3i}-\psi)\tan\theta_{13i})))c(\delta_{15i}+\delta_{17i})(-c\theta_{8i}c\theta_{9i}s\theta s\theta_{4i}s\phi)-c\theta_{4i}c\theta_{9i}s\delta_{6i}s\theta s\theta_{8i}s\phi-c\delta_{6i}c\theta_{4i}s\theta s\theta_{9i}s\phi+ \\
 & c\theta_{4i}c\theta_{8i}c\theta_{9i}c\phi s(\delta_{1i}+\delta_{3i})s\psi-c\theta_{9i}c\phi s(\delta_{1i}+\delta_{3i})s\delta_{6i}s\theta_{4i}s\theta_{8i}s\psi-c\delta_{6i}c\phi s(\delta_{1i}+\delta_{3i})s\theta_{4i}s\theta_{9i}s\psi+ \\
 & c\theta_{8i}c\theta_{9i}c\phi s\theta s\theta_{4i}\tan\theta_{13i}+c\theta_{4i}c\theta_{9i}c\phi s\delta_{6i}s\theta s\theta_{8i}\tan\theta_{13i}+c\delta_{6i}c\theta_{4i}c\phi s\theta s\theta_{9i}\tan\theta_{13i}+c\theta_{4i}c\theta_{8i}c\theta_{9i} \\
 & s(\delta_{1i}+\delta_{3i})s\phi s\psi\tan\theta_{13i}-c\theta_{9i}s(\delta_{1i}+\delta_{3i})s\delta_{6i}s\theta_{4i}s\theta_{8i}s\phi s\psi\tan\theta_{13i}-c\delta_{6i}s(\delta_{1i}+\delta_{3i})s\theta_{4i}s\theta_{9i}s\phi s\psi \\
 & \tan\theta_{13i}+c\theta c\psi s(\delta_{1i}+\delta_{3i})(c\theta_{4i}c\theta_{8i}c\theta_{9i}-s\theta_{4i}(c\theta_{9i}s\delta_{6i}s\theta_{8i}+c\delta_{6i}s\theta_{9i}))(s\phi-c\phi\tan\theta_{13i})+c(\delta_{1i}+ \\
 & \delta_{3i})(c\theta_{4i}c\theta_{8i}c\theta_{9i}-s\theta_{4i}(c\theta_{9i}s\delta_{6i}s\theta_{8i}+c\delta_{6i}s\theta_{9i}))(s\phi(-c\theta s\psi)+c\psi\tan\theta_{13i})+c\phi(c\psi+c\theta s\psi \\
 & \tan\theta_{13i}))))
 \end{aligned}$$

$$\begin{aligned}
 V_{43i} = & c\theta_{13i}^2c\theta_{9i}(c(\delta_{15i}+\delta_{17i})(-c\theta_{8i}s\delta_{6i}s\theta s\theta_{4i}s\phi)-c\theta_{4i}s\theta s\theta_{8i}s\phi+c\theta_{4i}c\theta_{8i}c\phi s(\delta_{1i}+\delta_{3i})s\delta_{6i}s\psi-c\phi \\
 & s(\delta_{1i}+\delta_{3i})s\theta_{4i}s\theta_{8i}s\psi+c\theta_{8i}c\phi s\delta_{6i}s\theta s\theta_{4i}\tan\theta_{13i}+c\theta_{4i}c\phi s\theta s\theta_{8i}\tan\theta_{13i}+c\theta_{4i}c\theta_{8i}s(\delta_{1i}+\delta_{3i})s\delta_{6i} \\
 & s\phi s\psi\tan\theta_{13i}-s(\delta_{1i}+\delta_{3i})s\theta_{4i}s\theta_{8i}s\phi s\psi\tan\theta_{13i}+c\theta c\psi s(\delta_{1i}+\delta_{3i})(c\theta_{4i}c\theta_{8i}s\delta_{6i}-s\theta_{4i}s\theta_{8i})(s\phi- \\
 & c\phi\tan\theta_{13i})+c\delta_{6i}c\theta_{8i}s(\delta_{1i}+\delta_{3i})(s\phi(-c\theta s\psi)+c\psi\tan\theta_{13i})+c\phi(c\psi+c\theta s\psi\tan\theta_{13i}))) + \\
 & s(\delta_{15i}+\delta_{17i})(\sec\theta_{13i}s\theta_{8i}(c\theta_{4i}c\theta_{13i}-\phi s\theta+s(\delta_{1i}+\delta_{3i})s\theta_{4i}s\theta_{13i}-\phi s\psi)-c\theta s(\delta_{1i}+\delta_{3i})(c\theta_{4i}c\theta_{8i}c\psi \\
 & s\delta_{6i}-c\psi s\theta_{4i}s\theta_{8i}-c\delta_{6i}c\theta_{8i}s\psi)(c\phi+s\phi\tan\theta_{13i})+c\theta_{8i}(s\phi(c\delta_{6i}c\psi s(\delta_{1i}+\delta_{3i})+c\theta_{4i}s(\delta_{1i}+\delta_{3i}) \\
 & s\delta_{6i}s\psi+s\delta_{6i}s\theta s\theta_{4i}\tan\theta_{13i})+c\phi(s\delta_{6i}s\theta s\theta_{4i}-c\delta_{6i}c\psi s(\delta_{1i}+\delta_{3i})\tan\theta_{13i}-c\theta_{4i}s(\delta_{1i}+\delta_{3i})s\delta_{6i}s\psi \\
 & \tan\theta_{13i})))c(\delta_{1i}+\delta_{3i})(c\delta_{6i}c\theta_{8i}\sec\theta_{13i}(2s(\delta_{15i}+\delta_{17i}+\theta_{13i}-\phi-\psi)+s(\delta_{15i}+\delta_{17i}-\theta+\theta_{13i}-\phi \\
 & -\psi)+s(\delta_{15i}+\delta_{17i}+\theta+\theta_{13i}-\phi-\psi))-2s(\delta_{15i}+\delta_{17i}+\theta_{13i}-\phi+\psi)+s(\delta_{15i}+\delta_{17i}-\theta+\theta_{13i}-\phi+\psi)+ \\
 & s(\delta_{15i}+\delta_{17i}+\theta+\theta_{13i}-\phi+\psi)))/4+(c\theta_{4i}c\theta_{8i}s\delta_{6i}-s\theta_{4i}s\theta_{8i})(s(\delta_{15i}+\delta_{17i})(c\psi(s\phi-c\phi\tan\theta_{13i})+ \\
 & c\theta s\psi(c\phi+s\phi\tan\theta_{13i}))+c(\delta_{15i}+\delta_{17i})(s\phi(-c\theta s\psi)+c\psi\tan\theta_{13i})+c\phi(c\psi+c\theta s\psi\tan\theta_{13i}))))))
 \end{aligned}$$

$$\begin{aligned}
V_{44i} = & c\theta_{13i}^2(-s(\delta_{15i} + \delta_{17i})(-c\theta_{4i}c\theta_{8i}c\phi s\theta s\theta_{9i}) - c\theta c\theta_{8i}c\phi c\psi s(\delta_{1i} + \delta_{3i})s\theta_{4i}s\theta_{9i} - c\theta c\theta_{4i}c\phi c\psi s(\delta_{1i} + \\
& \delta_{3i})s\delta_{6i}s\theta_{8i}s\theta_{9i} + c\phi s\delta_{6i}s\theta s\theta_{4i}s\theta_{8i}s\theta_{9i} + c\theta_{9i}c\psi s(\delta_{1i} + \delta_{3i})s\delta_{6i}s\phi + c\theta c\theta_{9i}c\phi s(\delta_{1i} + \delta_{3i})s\delta_{6i} \\
& s\psi + c\theta_{8i}s(\delta_{1i} + \delta_{3i})s\theta_{4i}s\theta_{9i}s\phi s\psi + c\theta_{4i}s(\delta_{1i} + \delta_{3i})s\delta_{6i}s\theta_{8i}s\theta_{9i}s\phi s\psi - c\theta_{9i}c\phi c\psi s(\delta_{1i} + \delta_{3i})s\delta_{6i} \\
& \tan \theta_{13i} - c\theta_{4i}c\theta_{8i}s\theta s\theta_{9i}s\phi \tan \theta_{13i} - c\theta c\theta_{8i}c\psi s(\delta_{1i} + \delta_{3i})s\theta_{4i}s\theta_{9i}s\phi \tan \theta_{13i} - c\theta c\theta_{4i}c\psi s(\delta_{1i} + \\
& \delta_{3i})s\delta_{6i}s\theta_{8i}s\theta_{9i}s\phi \tan \theta_{13i} + s\delta_{6i}s\theta s\theta_{4i}s\theta_{8i}s\theta_{9i}s\phi \tan \theta_{13i} - c\theta_{8i}c\phi s(\delta_{1i} + \delta_{3i})s\theta_{4i}s\theta_{9i}s\psi \tan \theta_{13i} - \\
& c\theta_{4i}c\phi s(\delta_{1i} + \delta_{3i})s\delta_{6i}s\theta_{8i}s\theta_{9i}s\psi \tan \theta_{13i} + c\theta c\theta_{9i}s(\delta_{1i} + \delta_{3i})s\delta_{6i}s\phi s\psi \tan \theta_{13i} + c(\delta_{1i} + \delta_{3i}) \\
& ((c\theta_{8i}c\psi s\theta_{4i}s\theta_{9i} + c\theta_{4i}c\psi s\delta_{6i}s\theta_{8i}s\theta_{9i} - c\theta_{9i}s\delta_{6i}s\psi - c\delta_{6i}(c\theta_{4i}c\theta_{9i}c\psi + s\theta_{8i}s\theta_{9i}s\psi))(s\phi - c\phi \\
& \tan \theta_{13i}) + c\theta(c\theta_{9i}c\psi s\delta_{6i} + (c\theta_{8i}s\theta_{4i} + c\theta_{4i}s\delta_{6i}s\theta_{8i})s\theta_{9i}s\psi)(c\phi + s\phi \tan \theta_{13i})) + c\delta_{6i}(s\theta_{8i}s\theta_{9i} \\
& (c\theta c\theta_{13i} - \phi c(\delta_{1i} + \delta_{3i} - \psi) \sec \theta_{13i} + c\psi s(\delta_{1i} + \delta_{3i})(s\phi - c\phi \tan \theta_{13i})) + c\theta_{9i}(-(s\phi(c\theta_{4i}s(\delta_{1i} + \delta_{3i}) \\
& s\psi + s\theta s\theta_{4i} \tan \theta_{13i} - c\theta c\theta_{4i}s(\delta_{1i} + \delta_{3i} - \psi) \tan \theta_{13i})) + c\phi(-(s\theta s\theta_{4i}) + c\theta c\theta_{4i}s(\delta_{1i} + \delta_{3i} - \psi) + \\
& c\theta_{4i}s(\delta_{1i} + \delta_{3i})s\psi \tan \theta_{13i})))) + c(\delta_{15i} + \delta_{17i})(c\theta_{9i}(-(c\phi(c\theta s(\delta_{1i} + \delta_{3i})s\delta_{6i}s\psi \tan \theta_{13i} + c\psi \\
& s(\delta_{1i} + \delta_{3i})(s\delta_{6i} + c\delta_{6i}c\theta c\theta_{4i} \tan \theta_{13i}) - c\delta_{6i}(c\theta_{4i}s(\delta_{1i} + \delta_{3i})s\psi + s\theta s\theta_{4i} \tan \theta_{13i})))) + s\phi(s(\delta_{1i} + \\
& \delta_{3i})s\delta_{6i}(c\theta s\psi - c\psi \tan \theta_{13i}) + c\delta_{6i}(c\theta c\theta_{4i}c\psi s(\delta_{1i} + \delta_{3i}) - s\theta s\theta_{4i} + c\theta_{4i}s(\delta_{1i} + \delta_{3i})s\psi \\
& \tan \theta_{13i}))) - s\theta_{9i}(s\theta_{4i}(-(c\theta c\theta_{8i}c\psi \sec \theta_{13i}s(\delta_{1i} + \delta_{3i})s(\theta_{13i} - \phi)) + \sec \theta_{13i}s\delta_{6i}s\theta s\theta_{8i}s(\theta_{13i} - \phi) + \\
& c\theta_{8i}s(\delta_{1i} + \delta_{3i})s\psi(c\phi + s\phi \tan \theta_{13i})) + c\delta_{6i}s(\delta_{1i} + \delta_{3i})s\theta_{8i}(s\phi - (c\theta s\psi) + c\psi \tan \theta_{13i}) + c\phi \\
& (c\psi + c\theta s\psi \tan \theta_{13i})) + c\theta_{4i}(-(c\theta_{8i} \sec \theta_{13i}s\theta s(\theta_{13i} - \phi)) + s(\delta_{1i} + \delta_{3i})s\delta_{6i}s\theta_{8i}(-(c\theta c\psi \sec \theta_{13i} \\
& s(\theta_{13i} - \phi)) + s\psi(c\phi + s\phi \tan \theta_{13i})))) + c(\delta_{1i} + \delta_{3i})(-(c\theta_{8i}s\theta_{4i}s\theta_{9i}(s\phi - (c\theta s\psi) + c\psi \tan \theta_{13i}) + \\
& c\phi(c\psi + c\theta s\psi \tan \theta_{13i}))) + c\delta_{6i}(s\theta_{8i}s\theta_{9i}(-(c\theta c\psi \sec \theta_{13i}s(\theta_{13i} - \phi)) + s\psi(c\phi + s\phi \tan \theta_{13i})) + \\
& c\theta_{4i}c\theta_{9i}(s\phi - (c\theta s\psi) + c\psi \tan \theta_{13i})) + c\phi(c\psi + c\theta s\psi \tan \theta_{13i}))) - s\delta_{6i}(c\theta_{9i}(c\theta c\psi \sec \theta_{13i} \\
& s(\theta_{13i} - \phi) - s\psi(c\phi + s\phi \tan \theta_{13i})) + c\theta_{4i}s\theta_{8i}s\theta_{9i}(s\phi - (c\theta s\psi) + c\psi \tan \theta_{13i}) + c\phi(c\psi + c\theta \\
& s\psi \tan \theta_{13i}))))))
\end{aligned}$$

Coeficientes de la ecuación (2.65):

$$V_{45i} = c_{21i} - c\theta_{13i}s\theta_{11i}$$

$$V_{46i} = 0$$

$$V_{47i} = 0$$

$$V_{48i} = 0$$

$$\begin{aligned}
V_{49i} = & -(c\theta_{12i}^2(c(\delta_{1i} + \delta_{3i})(-c\theta s\delta_{15i} + \delta_{17i} - \phi(c\theta_{11i}(c\theta_{8i}c\theta_{9i}c\psi s\theta_{4i} + c\theta_{4i}c\psi(c\theta_{9i}s\delta_{6i}s\theta_{8i} + c\delta_{6i}s\theta_{9i}) + \\
& -(c\delta_{6i}c\theta_{9i}s\theta_{8i}) + s\delta_{6i}s\theta_{9i})s\psi) + (c\theta_{4i}c\theta_{8i}c\psi s\delta_{6i} - c\psi s\theta_{4i}s\theta_{8i} - c\delta_{6i}c\theta_{8i}s\psi) \tan \theta_{12i})) + c\delta_{15i} + \\
& \delta_{17i} - \phi(c\theta_{11i}(-(c\psi s\delta_{6i}s\theta_{9i}) + c\theta_{9i}(c\theta_{8i}s\theta_{4i} + c\theta_{4i}s\delta_{6i}s\theta_{8i})s\psi) + (c\theta_{4i}c\theta_{8i}s\delta_{6i} - s\theta_{4i} \\
& s\theta_{8i})s\psi \tan \theta_{12i} + c\delta_{6i}(c\theta_{11i}(c\theta_{9i}c\psi s\theta_{8i} + c\theta_{4i}s\theta_{9i}s\psi) + c\theta_{8i}c\psi \tan \theta_{12i}))) - s(\delta_{1i} + \delta_{3i}) \\
& (c(\delta_{15i} + \delta_{17i})(c\theta_{11i}(-(c\delta_{6i}c\theta_{9i}s\theta_{8i} - s\delta_{6i}s\theta_{9i})(c\theta c\psi s\phi + c\phi s\psi)) + c\theta_{8i}c\theta_{9i}s\theta_{4i}(c\phi c\psi - c\theta s\phi \\
& s\psi) + c\theta_{4i}(c\theta_{9i}s\delta_{6i}s\theta_{8i} + c\delta_{6i}s\theta_{9i})(c\phi c\psi - c\theta s\phi s\psi)) + -(c\phi(c\psi s\theta_{4i}s\theta_{8i} + c\delta_{6i}c\theta_{8i}s\psi)) + \\
& c\theta s\phi(-(c\delta_{6i}c\theta_{8i}c\psi) + s\theta_{4i}s\theta_{8i}s\psi) + c\theta_{4i}c\theta_{8i}s\delta_{6i}(c\phi c\psi - c\theta s\phi s\psi)) \tan \theta_{12i} + s(\delta_{15i} + \delta_{17i}) \\
& (s\phi(c\theta_{11i}(c\theta_{8i}c\theta_{9i}c\psi s\theta_{4i} + c\theta_{4i}c\theta_{9i}c\psi s\delta_{6i}s\theta_{8i} + s\delta_{6i}s\theta_{9i}s\psi) + c\psi(c\theta_{4i}c\theta_{8i}s\delta_{6i} - s\theta_{4i}s\theta_{8i}) \\
& \tan \theta_{12i}) + c\theta c\phi(c\theta_{11i}(-(c\psi s\delta_{6i}s\theta_{9i}) + c\theta_{9i}(c\theta_{8i}s\theta_{4i} + c\theta_{4i}s\delta_{6i}s\theta_{8i})s\psi) + (c\theta_{4i}c\theta_{8i}s\delta_{6i} - s\theta_{4i} \\
& s\theta_{8i})s\psi \tan \theta_{12i}) + c\delta_{6i}(c\theta c\phi(c\theta_{11i}c\theta_{9i}c\psi s\theta_{8i} + c\theta_{11i}c\theta_{4i}s\theta_{9i}s\psi + c\theta_{8i}c\psi \tan \theta_{12i}) + s\phi(c\theta_{11i}
\end{aligned}$$

$$\begin{aligned}
 & c\theta_{4i}c\psi s\theta_{9i} - c\theta_{11i}c\theta_{9i}s\theta_{8i}s\psi - c\theta_{8i}s\psi \tan \theta_{12i})))))) \\
 V_{50i} = & -(c\theta_{12i}^2s\delta_{15i} + \delta_{17i} - \phi(c\theta(c\theta_{11i}(c\theta_{4i}c\theta_{8i}c\theta_{9i} - s\theta_{4i}(c\theta_{9i}s\delta_{6i}s\theta_{8i} + c\delta_{6i}s\theta_{9i})) - (c\theta_{8i}s\delta_{6i}s\theta_{4i} + c\theta_{4i}s\theta_{8i}) \\
 & \tan \theta_{12i}) + s\theta(c\theta_{11i}(-(c\theta_{4i}c\psi s(\delta_{1i} + \delta_{3i}))(c\theta_{9i}s\delta_{6i}s\theta_{8i} + c\delta_{6i}s\theta_{9i})) - c\theta_{8i}c\theta_{9i}s\theta_{4i}s(\delta_{1i} + \delta_{3i}) - \psi) + \\
 & c\delta_{6i}c\theta_{9i}s(\delta_{1i} + \delta_{3i})s\theta_{8i}s\psi - s(\delta_{1i} + \delta_{3i})s\delta_{6i}s\theta_{9i}s\psi + c(\delta_{1i} + \delta_{3i})(s\delta_{6i}(-(c\psi s\theta_{9i}) + c\theta_{4i}c\theta_{9i}s\theta_{8i} \\
 & s\psi) + c\delta_{6i}(c\theta_{9i}c\psi s\theta_{8i} + c\theta_{4i}s\theta_{9i}s\psi))) + (s(\delta_{1i} + \delta_{3i})(-(c\theta_{4i}c\theta_{8i}c\psi s\delta_{6i}) + c\psi s\theta_{4i}s\theta_{8i} + c\delta_{6i} \\
 & c\theta_{8i}s\psi) + c(\delta_{1i} + \delta_{3i})(c\delta_{6i}c\theta_{8i}c\psi + (c\theta_{4i}c\theta_{8i}s\delta_{6i} - s\theta_{4i}s\theta_{8i})s\psi)) \tan \theta_{12i}))) \\
 V_{51i} = & -(c\theta_{12i}^2(-(c(\delta_{15i} + \delta_{17i})c\theta_{11i}c\phi s\theta(c\theta_{4i}c\theta_{8i}c\theta_{9i} - s\theta_{4i}(c\theta_{9i}s\delta_{6i}s\theta_{8i} + c\delta_{6i}s\theta_{9i}))) - c\theta_{11i}c\phi c\psi s(\delta_{15i} + \\
 & \delta_{17i})(s(\delta_{1i} + \delta_{3i}))(c\delta_{6i}c\theta_{9i}s\theta_{8i} - s\delta_{6i}s\theta_{9i}) + c(\delta_{1i} + \delta_{3i})(c\theta_{8i}c\theta_{9i}s\theta_{4i} + c\theta_{4i}(c\theta_{9i}s\delta_{6i}s\theta_{8i} + c\delta_{6i} \\
 & s\theta_{9i}))) - c(\delta_{15i} + \delta_{17i})c\theta c\theta_{11i}c\phi c\psi (c(\delta_{1i} + \delta_{3i})(-(c\delta_{6i}c\theta_{9i}s\theta_{8i}) + s\delta_{6i}s\theta_{9i}) + s(\delta_{1i} + \delta_{3i})(c\theta_{8i}c\theta_{9i} \\
 & s\theta_{4i} + c\theta_{4i}(c\theta_{9i}s\delta_{6i}s\theta_{8i} + c\delta_{6i}s\theta_{9i}))) - c\theta_{11i}s(\delta_{15i} + \delta_{17i})s\theta(c\theta_{4i}c\theta_{8i}c\theta_{9i} - s\theta_{4i}(c\theta_{9i}s\delta_{6i}s\theta_{8i} + c\delta_{6i} \\
 & s\theta_{9i}))s\phi + c(\delta_{15i} + \delta_{17i})c\theta_{11i}c\psi (s(\delta_{1i} + \delta_{3i}))(c\delta_{6i}c\theta_{9i}s\theta_{8i} - s\delta_{6i}s\theta_{9i}) + c(\delta_{1i} + \delta_{3i})(c\theta_{8i}c\theta_{9i}s\theta_{4i} + \\
 & c\theta_{4i}(c\theta_{9i}s\delta_{6i}s\theta_{8i} + c\delta_{6i}s\theta_{9i})))s\phi - c\theta c\theta_{11i}c\psi s(\delta_{15i} + \delta_{17i})(c(\delta_{1i} + \delta_{3i})(-(c\delta_{6i}c\theta_{9i}s\theta_{8i}) + s\delta_{6i}s\theta_{9i}) + \\
 & s(\delta_{1i} + \delta_{3i})(c\theta_{8i}c\theta_{9i}s\theta_{4i} + c\theta_{4i}(c\theta_{9i}s\delta_{6i}s\theta_{8i} + c\delta_{6i}s\theta_{9i})))s\phi + c(\delta_{15i} + \delta_{17i})c\theta c\theta_{11i}c\phi (s(\delta_{1i} + \delta_{3i}) \\
 & (c\delta_{6i}c\theta_{9i}s\theta_{8i} - s\delta_{6i}s\theta_{9i}) + c(\delta_{1i} + \delta_{3i})(c\theta_{8i}c\theta_{9i}s\theta_{4i} + c\theta_{4i}(c\theta_{9i}s\delta_{6i}s\theta_{8i} + c\delta_{6i}s\theta_{9i})))s\psi - c\theta_{11i}c\phi \\
 & s(\delta_{15i} + \delta_{17i})(c(\delta_{1i} + \delta_{3i})(-(c\delta_{6i}c\theta_{9i}s\theta_{8i}) + s\delta_{6i}s\theta_{9i}) + s(\delta_{1i} + \delta_{3i})(c\theta_{8i}c\theta_{9i}s\theta_{4i} + c\theta_{4i}(c\theta_{9i}s\delta_{6i}s\theta_{8i} + \\
 & c\delta_{6i}s\theta_{9i})))s\psi + c\theta c\theta_{11i}s(\delta_{15i} + \delta_{17i})(s(\delta_{1i} + \delta_{3i}))(c\delta_{6i}c\theta_{9i}s\theta_{8i} - s\delta_{6i}s\theta_{9i}) + c(\delta_{1i} + \delta_{3i})(c\theta_{8i}c\theta_{9i} \\
 & s\theta_{4i} + c\theta_{4i}(c\theta_{9i}s\delta_{6i}s\theta_{8i} + c\delta_{6i}s\theta_{9i})))s\phi s\psi + c(\delta_{15i} + \delta_{17i})c\theta_{11i}(c(\delta_{1i} + \delta_{3i})(-(c\delta_{6i}c\theta_{9i}s\theta_{8i}) + s\delta_{6i} \\
 & s\theta_{9i}) + s(\delta_{1i} + \delta_{3i})(c\theta_{8i}c\theta_{9i}s\theta_{4i} + c\theta_{4i}(c\theta_{9i}s\delta_{6i}s\theta_{8i} + c\delta_{6i}s\theta_{9i})))s\phi s\psi + c(\delta_{15i} + \delta_{17i})c\phi s\theta(c\theta_{8i}s\delta_{6i} \\
 & s\theta_{4i} + c\theta_{4i}s\theta_{8i}) \tan \theta_{12i} - c\phi c\psi s(\delta_{15i} + \delta_{17i})(c\delta_{6i}c\theta_{8i}s(\delta_{1i} + \delta_{3i}) + c(\delta_{1i} + \delta_{3i})(c\theta_{4i}c\theta_{8i}s\delta_{6i} - s\theta_{4i} \\
 & s\theta_{8i})) \tan \theta_{12i} + c(\delta_{15i} + \delta_{17i})c\theta c\phi c\psi (c(\delta_{1i} + \delta_{3i})c\delta_{6i}c\theta_{8i} + s(\delta_{1i} + \delta_{3i})(-(c\theta_{4i}c\theta_{8i}s\delta_{6i}) + s\theta_{4i} \\
 & s\theta_{8i})) \tan \theta_{12i} + s(\delta_{15i} + \delta_{17i})s\theta(c\theta_{8i}s\delta_{6i}s\theta_{4i} + c\theta_{4i}s\theta_{8i})s\phi \tan \theta_{12i} + c(\delta_{15i} + \delta_{17i})c\psi (c\delta_{6i}c\theta_{8i} \\
 & s(\delta_{1i} + \delta_{3i}) + c(\delta_{1i} + \delta_{3i})(c\theta_{4i}c\theta_{8i}s\delta_{6i} - s\theta_{4i}s\theta_{8i}))s\phi \tan \theta_{12i} + c\theta c\psi s(\delta_{15i} + \delta_{17i})(c(\delta_{1i} + \delta_{3i})c\delta_{6i} \\
 & c\theta_{8i} + s(\delta_{1i} + \delta_{3i})(-(c\theta_{4i}c\theta_{8i}s\delta_{6i}) + s\theta_{4i}s\theta_{8i}))s\phi \tan \theta_{12i} + c(\delta_{15i} + \delta_{17i})c\theta c\phi (c\delta_{6i}c\theta_{8i}s(\delta_{1i} + \delta_{3i}) + \\
 & c(\delta_{1i} + \delta_{3i})(c\theta_{4i}c\theta_{8i}s\delta_{6i} - s\theta_{4i}s\theta_{8i}))s\psi \tan \theta_{12i} + c\phi s(\delta_{15i} + \delta_{17i})(c(\delta_{1i} + \delta_{3i})c\delta_{6i}c\theta_{8i} + s(\delta_{1i} + \delta_{3i}) \\
 & c\theta_{8i} + s(\delta_{1i} + \delta_{3i})(-(c\theta_{4i}c\theta_{8i}s\delta_{6i}) + s\theta_{4i}s\theta_{8i})) \\
 V_{52i} = & -(c\theta_{12i}^2(-(c\theta_{11i}c\theta_{8i}c\theta_{9i}c\phi s(\delta_{15i} + \delta_{17i})s\theta s\theta_{4i}) - c\theta_{11i}c\theta_{4i}c\phi s(\delta_{15i} + \delta_{17i})s\theta(c\theta_{9i}s\delta_{6i}s\theta_{8i} + c\delta_{6i}s\theta_{9i})) + \\
 & c(\delta_{15i} + \delta_{17i})c\theta_{11i}c\theta_{8i}c\theta_{9i}s\theta s\theta_{4i}s\phi + c(\delta_{15i} + \delta_{17i})c\theta_{11i}c\theta_{4i}s\theta(c\theta_{9i}s\delta_{6i}s\theta_{8i} + c\delta_{6i}s\theta_{9i}))s\phi - c(\delta_{15i} + \\
 & \delta_{17i})c\theta_{11i}c\theta_{4i}c\theta_{8i}c\theta_{9i}s(\delta_{1i} + \delta_{3i})(c\theta c\psi s\phi + c\phi s\psi) + c(\delta_{15i} + \delta_{17i})c\theta_{11i}s(\delta_{1i} + \delta_{3i})s\theta_{4i}(c\theta_{9i}s\delta_{6i}s\theta_{8i} + \\
 & c\delta_{6i}s\theta_{9i})(c\theta c\psi s\phi + c\phi s\psi) + c(\delta_{1i} + \delta_{3i})c\theta_{11i}c\theta_{4i}c\theta_{8i}c\theta_{9i}s(\delta_{15i} + \delta_{17i})(-(c\psi s\phi) - c\theta c\phi \\
 & s\psi) - c(\delta_{1i} + \delta_{3i})c\theta_{11i}s(\delta_{15i} + \delta_{17i})s\theta_{4i}(c\theta_{9i}s\delta_{6i}s\theta_{8i} + c\delta_{6i}s\theta_{9i})(-(c\psi s\phi) - c\theta c\phi s\psi) + c\theta_{11i}c\theta_{4i} \\
 & c\theta_{8i}c\theta_{9i}s(\delta_{15i} + \delta_{17i})s(\delta_{1i} + \delta_{3i})(c\theta c\phi c\psi - s\phi s\psi) - c\theta_{11i}s(\delta_{15i} + \delta_{17i})s(\delta_{1i} + \delta_{3i})s\theta_{4i}(c\theta_{9i}s\delta_{6i}s\theta_{8i} + \\
 & c\delta_{6i}s\theta_{9i})(c\theta c\phi c\psi - s\phi s\psi) - c(\delta_{15i} + \delta_{17i})c(\delta_{1i} + \delta_{3i})c\theta_{11i}c\theta_{4i}c\theta_{8i}c\theta_{9i}(c\phi c\psi - c\theta s\phi s\psi) + c(\delta_{15i} + \\
 & \delta_{17i})c(\delta_{1i} + \delta_{3i})c\theta_{11i}s\theta_{4i}(c\theta_{9i}s\delta_{6i}s\theta_{8i} + c\delta_{6i}s\theta_{9i})(c\phi c\psi - c\theta s\phi s\psi) - c\theta_{4i}c\theta_{8i}c\phi s(\delta_{15i} + \delta_{17i})s\delta_{6i}s\theta \\
 & \tan \theta_{12i} + c\phi s(\delta_{15i} + \delta_{17i})s\theta s\theta_{4i}s\theta_{8i} \tan \theta_{12i} + c(\delta_{15i} + \delta_{17i})c\theta_{4i}c\theta_{8i}s\delta_{6i}s\theta s\phi \tan \theta_{12i} - c(\delta_{15i} + \delta_{17i}) \\
 & s\theta s\theta_{4i}s\theta_{8i}s\phi \tan \theta_{12i} + c(\delta_{15i} + \delta_{17i})c\theta_{8i}s(\delta_{1i} + \delta_{3i})s\delta_{6i}s\theta_{4i}(c\theta c\psi s\phi + c\phi s\psi) \tan \theta_{12i} + c(\delta_{15i} + \\
 & \delta_{17i})c\theta_{4i}s(\delta_{1i} + \delta_{3i})s\theta_{8i}(c\theta c\psi s\phi + c\phi s\psi) \tan \theta_{12i} + c(\delta_{1i} + \delta_{3i})c\theta_{8i}s(\delta_{15i} + \delta_{17i})s\delta_{6i}s\theta_{4i}(c\psi s\phi + \\
 & c\theta c\phi s\psi) \tan \theta_{12i} + c(\delta_{1i} + \delta_{3i})c\theta_{4i}s(\delta_{15i} + \delta_{17i})s\theta_{8i}(c\psi s\phi + c\theta c\phi s\psi) \tan \theta_{12i} - c\theta_{8i}s(\delta_{15i} + \delta_{17i}) \\
 & s(\delta_{1i} + \delta_{3i})s\delta_{6i}s\theta_{4i}(c\theta c\phi c\psi - s\phi s\psi) \tan \theta_{12i} - c\theta_{4i}s(\delta_{15i} + \delta_{17i})s(\delta_{1i} + \delta_{3i})s\theta_{8i}(c\theta c\phi c\psi - s\phi s\psi) \\
 & \tan \theta_{12i} + c(\delta_{15i} + \delta_{17i})c(\delta_{1i} + \delta_{3i})c\theta_{8i}s\delta_{6i}s\theta_{4i}(c\phi c\psi - c\theta s\phi s\psi) \tan \theta_{12i} + c(\delta_{15i} + \delta_{17i})c(\delta_{1i} + \delta_{3i})
 \end{aligned}$$

$$\begin{aligned}
V_{55i} = & -(c\theta_{12i}^2 (s\theta_{11i} (-s(\delta_{15i} + \delta_{17i})(c\phi s\theta(c\theta_{4i}c\theta_{8i}c\theta_{9i} - s\theta_{4i}(c\theta_{9i}s\delta_{6i}s\theta_{8i} + c\delta_{6i}s\theta_{9i}))) + (s(\delta_{1i} + \delta_{3i})(c\delta_{6i} \\
& c\theta_{9i}s\theta_{8i} - s\delta_{6i}s\theta_{9i}) + c(\delta_{1i} + \delta_{3i})(c\theta_{8i}c\theta_{9i}s\theta_{4i} + c\theta_{4i}(c\theta_{9i}s\delta_{6i}s\theta_{8i} + c\delta_{6i}s\theta_{9i}))))(-c\psi s\phi) - c\theta c\phi \\
& s\psi) + (c(\delta_{1i} + \delta_{3i})(-c\delta_{6i}c\theta_{9i}s\theta_{8i}) + s\delta_{6i}s\theta_{9i}) + s(\delta_{1i} + \delta_{3i})(c\theta_{8i}c\theta_{9i}s\theta_{4i} + c\theta_{4i}(c\theta_{9i}s\delta_{6i}s\theta_{8i} + c\delta_{6i} \\
& s\theta_{9i}))) (c\theta c\phi c\psi - s\phi s\psi)) + c(\delta_{15i} + \delta_{17i})(s\theta(c\theta_{4i}c\theta_{8i}c\theta_{9i} - s\theta_{4i}(c\theta_{9i}s\delta_{6i}s\theta_{8i} + c\delta_{6i}s\theta_{9i})))s\phi + \\
& (c(\delta_{1i} + \delta_{3i})(-c\delta_{6i}c\theta_{9i}s\theta_{8i}) + s\delta_{6i}s\theta_{9i}) + s(\delta_{1i} + \delta_{3i})(c\theta_{8i}c\theta_{9i}s\theta_{4i} + c\theta_{4i}(c\theta_{9i}s\delta_{6i}s\theta_{8i} + c\delta_{6i}s\theta_{9i}))) \\
& (c\theta c\psi s\phi + c\phi s\psi) + (s(\delta_{1i} + \delta_{3i})(c\delta_{6i}c\theta_{9i}s\theta_{8i} - s\delta_{6i}s\theta_{9i}) + c(\delta_{1i} + \delta_{3i})(c\theta_{8i}c\theta_{9i}s\theta_{4i} + c\theta_{4i}(c\theta_{9i}s\delta_{6i} \\
& s\theta_{8i} + c\delta_{6i}s\theta_{9i}))) (c\phi c\psi - c\theta s\phi s\psi)) - c\theta_{11i}c\theta_{13i} \tan \theta_{12i} \\
V_{56i} = & -(c\theta_{12i}s\theta_{11i}s\theta_{12i}s\theta_{13i})
\end{aligned}$$

Apéndice D

Coeficientes de la ecuación (2.70):

$$\begin{aligned}
 G_{1i} &= 2(-x_p + x_{2i}c\delta_{1i} + c(\delta_{1i} + \delta_{3i})(x_{5i} + x_{7i}c\delta_{6i})c\theta_{4i} + x_{16i}c(\delta_{17i} - \phi)c\psi + x_{14i}c(\delta_{15i} + \delta_{17i} - \phi)c\psi - x_{7i} \\
 &\quad s(\delta_{1i} + \delta_{3i})s\delta_{6i} + c\theta(x_{16i}s(\delta_{17i} - \phi) + x_{14i}s(\delta_{15i} + \delta_{17i} - \phi))s\psi) \\
 G_{2i} &= 2(-y_p + x_{2i}s\delta_{1i} + (x_{5i} + x_{7i}c\delta_{6i})c\theta_{4i}s(\delta_{1i} + \delta_{3i}) + x_{7i}c(\delta_{1i} + \delta_{3i})s\delta_{6i} - c\theta c\psi(x_{16i}s(\delta_{17i} - \phi) + x_{14i} \\
 &\quad s(\delta_{15i} + \delta_{17i} - \phi)) + (x_{16i}c(\delta_{17i} - \phi) + x_{14i}c(\delta_{15i} + \delta_{17i} - \phi))s\psi) \\
 G_{3i} &= -2(z_p + (x_{5i} + x_{7i}c\delta_{6i})s\theta_{4i} + s\theta(x_{16i}s(\delta_{17i} - \phi) + x_{14i}s(\delta_{15i} + \delta_{17i} - \phi))) \\
 G_{4i} &= 2((x_{16i}c(\delta_{17i} - \phi) + x_{14i}c(\delta_{15i} + \delta_{17i} - \phi))c\psi(y_p - x_{2i}s\delta_{1i}) - x_{7i}(x_{16i}c(\delta_{17i} - \phi) + x_{14i}c(\delta_{15i} + \delta_{17i} - \phi)) \\
 &\quad c(\delta_{1i} + \delta_{3i} - \psi)s\delta_{6i} - x_{2i}c\theta c\delta_{1i} - \psi(x_{16i}s(\delta_{17i} - \phi) + x_{14i}s(\delta_{15i} + \delta_{17i} - \phi)) - (x_{5i} + x_{7i}c\delta_{6i})c\theta c\theta_{4i}c(\delta_{1i} + \\
 &\quad \delta_{3i} - \psi)(x_{16i}s(\delta_{17i} - \phi) + x_{14i}s(\delta_{15i} + \delta_{17i} - \phi)) + x_p c\theta c\psi(x_{16i}s(\delta_{17i} - \phi) + x_{14i}s(\delta_{15i} + \delta_{17i} - \phi)) - (x_{5i} + \\
 &\quad x_{7i}c\delta_{6i})c\theta_{4i}(x_{16i}c(\delta_{17i} - \phi) + x_{14i}c(\delta_{15i} + \delta_{17i} - \phi))s(\delta_{1i} + \delta_{3i} - \psi) + x_{7i}c\theta s\delta_{6i}(x_{16i}s(\delta_{17i} - \phi) + x_{14i} \\
 &\quad s(\delta_{15i} + \delta_{17i} - \phi))s(\delta_{1i} + \delta_{3i} - \psi) - (x_p - x_{2i}c\delta_{1i})(x_{16i}c(\delta_{17i} - \phi) + x_{14i}c(\delta_{15i} + \delta_{17i} - \phi))s\psi + y_p c\theta(x_{16i} \\
 &\quad s(\delta_{17i} - \phi) + x_{14i}s(\delta_{15i} + \delta_{17i} - \phi))s\psi) \\
 G_{5i} &= 2(x_{16i}s(\delta_{17i} - \phi) + x_{14i}s(\delta_{15i} + \delta_{17i} - \phi))(-z_p c\theta) - (x_{5i} + x_{7i}c\delta_{6i})c\theta s\theta_{4i} - (x_{5i} + x_{7i}c\delta_{6i})c\theta_{4i}s\theta s(\delta_{1i} + \\
 &\quad \delta_{3i} - \psi) - s\theta(-(y_p c\psi) + x_{7i}c(\delta_{1i} + \delta_{3i} - \psi)s\delta_{6i} + x_{2i}s\delta_{1i} - \psi + x_p s\psi) \\
 G_{6i} &= 2(x_{16i}z_p c(\delta_{17i} - \phi)s\theta + x_{14i}z_p c(\delta_{15i} + \delta_{17i} - \phi)s\theta + x_{16i}(x_{5i} + x_{7i}c\delta_{6i})c(\delta_{17i} - \phi)s\theta s\theta_{4i} + x_{14i}(x_{5i} + x_{7i} \\
 &\quad c\delta_{6i})c(\delta_{15i} + \delta_{17i} - \phi)s\theta s\theta_{4i} - x_{16i}(x_{5i} + x_{7i}c\delta_{6i})c\theta_{4i}c(\delta_{1i} + \delta_{3i} - \psi)s(\delta_{17i} - \phi) + x_{16i}(x_p - x_{2i}c\delta_{1i})c\psi \\
 &\quad s(\delta_{17i} - \phi) - x_{14i}(x_{5i} + x_{7i}c\delta_{6i})c\theta_{4i}c(\delta_{1i} + \delta_{3i} - \psi)s(\delta_{15i} + \delta_{17i} - \phi) + x_{14i}(x_p - x_{2i}c\delta_{1i})c\psi s(\delta_{15i} + \delta_{17i} - \\
 &\quad \phi) - x_{16i}(x_{5i} + x_{7i}c\delta_{6i})c\theta c\theta_{4i}c(\delta_{17i} - \phi)s(\delta_{1i} + \delta_{3i} - \psi) - x_{14i}(x_{5i} + x_{7i}c\delta_{6i})c\theta c\theta_{4i}c(\delta_{15i} + \delta_{17i} - \phi) \\
 &\quad s(\delta_{1i} + \delta_{3i} - \psi) + x_{16i}x_{7i}s\delta_{6i}s(\delta_{17i} - \phi)s(\delta_{1i} + \delta_{3i} - \psi) + x_{14i}x_{7i}s\delta_{6i}s(\delta_{15i} + \delta_{17i} - \phi)s(\delta_{1i} + \delta_{3i} - \psi) + x_{16i} \\
 &\quad (y_p - x_{2i}s\delta_{1i})s(\delta_{17i} - \phi)s\psi + x_{14i}(y_p - x_{2i}s\delta_{1i})s(\delta_{15i} + \delta_{17i} - \phi)s\psi - x_{16i}c\theta c(\delta_{17i} - \phi)(-(y_p c\psi) + x_{7i} \\
 &\quad c(\delta_{1i} + \delta_{3i} - \psi)s\delta_{6i} + x_{2i}s(\delta_{1i} - \psi) + x_p s\psi) - x_{14i}c\theta c(\delta_{15i} + \delta_{17i} - \phi)(-(y_p c\psi) + x_{7i}c(\delta_{1i} + \delta_{3i} - \psi) \\
 &\quad s\delta_{6i} + x_{2i}s(\delta_{1i} - \psi) + x_p s\psi)) \\
 G_{7i} &= -2\dot{x}_p^2 - 2\dot{y}_p^2 - 2\dot{z}_p^2 + 2\dot{\phi}^2 x_{16i}(x_{5i} + x_{7i}c\delta_{6i})c\theta_{4i}c(\delta_{17i} - \phi)c(\delta_{1i} + \delta_{3i} - \psi) + 2\dot{\phi}^2 x_{14i}(x_{5i} + x_{7i}c\delta_{6i})c\theta_{4i} \\
 &\quad c(\delta_{15i} + \delta_{17i} - \phi)c(\delta_{1i} + \delta_{3i} - \psi) + 2\dot{\psi}^2(x_{5i} + x_{7i}c\delta_{6i})c\theta_{4i}(x_{16i}c(\delta_{17i} - \phi) + x_{14i}c(\delta_{15i} + \delta_{17i} - \phi)) \\
 &\quad c(\delta_{1i} + \delta_{3i} - \psi) + 4\dot{\phi}\dot{\psi}(x_{5i} + x_{7i}c\delta_{6i})c\theta c\theta_{4i}(x_{16i}c(\delta_{17i} - \phi) + x_{14i}c(\delta_{15i} + \delta_{17i} - \phi))c(\delta_{1i} + \delta_{3i} - \psi) - \\
 &\quad 2\dot{\phi}^2 x_{16i}(x_p - x_{2i}c\delta_{1i})c(\delta_{17i} - \phi)c\psi - 2\dot{\phi}^2 x_{14i}(x_p - x_{2i}c\delta_{1i})c(\delta_{15i} + \delta_{17i} - \phi)c\psi + 4\dot{\psi}y_p(x_{16i}c(\delta_{17i} - \phi) + \\
 &\quad x_{14i}c(\delta_{15i} + \delta_{17i} - \phi))c\psi - 2\dot{\psi}^2(x_p - x_{2i}c\delta_{1i})(x_{16i}c(\delta_{17i} - \phi) + x_{14i}c(\delta_{15i} + \delta_{17i} - \phi))c\psi + 4\dot{\phi}z_p(x_{16i} \\
 &\quad c(\delta_{17i} - \phi) + x_{14i}c(\delta_{15i} + \delta_{17i} - \phi))s\theta + 4\dot{\theta}\dot{\phi}(x_{5i} + x_{7i}c\delta_{6i})c\theta(x_{16i}c(\delta_{17i} - \phi) + x_{14i}c(\delta_{15i} + \delta_{17i} - \phi)) \\
 &\quad s\theta_{4i} + 2\dot{\phi}^2 x_{16i}z_p s\theta s(\delta_{17i} - \phi) + 2\dot{\phi}^2 x_{16i}(x_{5i} + x_{7i}c\delta_{6i})s\theta s\theta_{4i}s(\delta_{17i} - \phi) + 2\dot{\phi}^2 x_{14i}z_p s\theta s(\delta_{15i} + \delta_{17i} - \phi) +
 \end{aligned}$$

$$\begin{aligned}
& 2\dot{\phi}^2 x_{14i}(x_{5i} + x_{7i} c\delta_{6i})s\theta s\theta_{4i}s(\delta_{15i} + \delta_{17i} - \phi) + 4\dot{\psi}\dot{x}_p c\theta c\psi(x_{16i}s(\delta_{17i} - \phi) + x_{14i}s(\delta_{15i} + \delta_{17i} - \phi)) + \\
& 2\dot{\psi}^2 y_p c\theta c\psi(x_{16i}s(\delta_{17i} - \phi) + x_{14i}s(\delta_{15i} + \delta_{17i} - \phi)) - 4\dot{\phi}\dot{\psi}x_{7i}c(\delta_i + \delta_{3i} - \psi)s\delta_{6i}(x_{16i}s(\delta_{17i} - \phi) + x_{14i} \\
& s(\delta_{15i} + \delta_{17i} - \phi)) - 2\dot{\psi}^2 x_{7i}c\theta c(\delta_i + \delta_{3i} - \psi)s\delta_{6i}(x_{16i}s(\delta_{17i} - \phi) + x_{14i}s(\delta_{15i} + \delta_{17i} - \phi)) + 2\dot{\theta}^2 z_p s\theta \\
& (x_{16i}s(\delta_{17i} - \phi) + x_{14i}s(\delta_{15i} + \delta_{17i} - \phi)) + 2\dot{\theta}^2 (x_{5i} + x_{7i}c\delta_{6i})s\theta s\theta_{4i}(x_{16i}s(\delta_{17i} - \phi) + x_{14i}s(\delta_{15i} + \delta_{17i} - \\
& \phi)) + 4\dot{\theta}c\theta(\dot{\phi}x_{16i}z_p c(\delta_{17i} - \phi) + \dot{\phi}x_{14i}z_p c(\delta_{15i} + \delta_{17i} - \phi) - \dot{z}_p(x_{16i}s(\delta_{17i} - \phi) + x_{14i}s(\delta_{15i} + \delta_{17i} - \phi))) - \\
& 4\dot{\theta}_{4i}(x_{5i} + x_{7i}c\delta_{6i})c\theta_{4i}(\dot{z}_p - \dot{\phi}(x_{16i}c(\delta_{17i} - \phi) + x_{14i}c(\delta_{15i} + \delta_{17i} - \phi)))s\theta + \dot{\theta}c\theta(x_{16i}s(\delta_{17i} - \phi) + x_{14i} \\
& s(\delta_{15i} + \delta_{17i} - \phi)) + 2\dot{\theta}_{4i}^2(x_{5i} + x_{7i}c\delta_{6i})s\theta_{4i}(z_p + s\theta(x_{16i}s(\delta_{17i} - \phi) + x_{14i}s(\delta_{15i} + \delta_{17i} - \phi))) - 2\dot{\psi}^2 x_{2i} \\
& c\theta(x_{16i}s(\delta_{17i} - \phi) + x_{14i}s(\delta_{15i} + \delta_{17i} - \phi))s(\delta_i - \psi) - 2\dot{\phi}^2 x_{16i}x_{7i}c(\delta_{17i} - \phi)s\delta_{6i}s(\delta_i + \delta_{3i} - \psi) - 2\dot{\phi}^2 x_{14i} \\
& x_{7i}c(\delta_{15i} + \delta_{17i} - \phi)s\delta_{6i}s(\delta_i + \delta_{3i} - \psi) - 2\dot{\psi}^2 x_{7i}(x_{16i}c(\delta_{17i} - \phi) + x_{14i}c(\delta_{15i} + \delta_{17i} - \phi))s\delta_{6i}s(\delta_i + \delta_{3i} - \\
& \psi) - 2\dot{\phi}^2 x_{16i}(x_{5i} + x_{7i}c\delta_{6i})c\theta c\theta_{4i}s(\delta_{17i} - \phi)s(\delta_i + \delta_{3i} - \psi) - 2\dot{\phi}^2 x_{14i}(x_{5i} + x_{7i}c\delta_{6i})c\theta c\theta_{4i}s(\delta_{15i} + \delta_{17i} - \\
& \phi)s(\delta_i + \delta_{3i} - \psi) - 4\dot{\phi}\dot{\psi}(x_{5i} + x_{7i}c\delta_{6i})c\theta_{4i}(x_{16i}s(\delta_{17i} - \phi) + x_{14i}s(\delta_{15i} + \delta_{17i} - \phi))s(\delta_i + \delta_{3i} - \psi) - 2\dot{\theta}^2 \\
& (x_{5i} + x_{7i}c\delta_{6i})c\theta c\theta_{4i}(x_{16i}s(\delta_{17i} - \phi) + x_{14i}s(\delta_{15i} + \delta_{17i} - \phi))s(\delta_i + \delta_{3i} - \psi) - 2\dot{\psi}^2(x_{5i} + x_{7i}c\delta_{6i})c\theta c\theta_{4i} \\
& (x_{16i}s(\delta_{17i} - \phi) + x_{14i}s(\delta_{15i} + \delta_{17i} - \phi))s(\delta_i + \delta_{3i} - \psi) + 4\dot{\theta}(-x_{5i} - x_{7i}c\delta_{6i})c\theta_{4i}s\theta(-(\dot{\psi}c(\delta_i + \delta_{3i} - \psi) \\
& (x_{16i}s(\delta_{17i} - \phi) + x_{14i}s(\delta_{15i} + \delta_{17i} - \phi))) - \dot{\phi}(x_{16i}c(\delta_{17i} - \phi) + x_{14i}c(\delta_{15i} + \delta_{17i} - \phi))s(\delta_i + \delta_{3i} - \psi)) + \dot{\theta}_{4i}^2 \\
& (x_{5i} + x_{7i}c\delta_{6i})c\theta_{4i}(2x_{2i}c\delta_{3i} - 2x_p c(\delta_i + \delta_{3i})) + 2(x_{16i}c(\delta_{17i} - \phi) + x_{14i}c(\delta_{15i} + \delta_{17i} - \phi))c(\delta_i + \delta_{3i} - \psi) - \\
& 2y_p s(\delta_i + \delta_{3i}) - 2c\theta(x_{16i}s(\delta_{17i} - \phi) + x_{14i}s(\delta_{15i} + \delta_{17i} - \phi))s(\delta_i + \delta_{3i} - \psi) + 4\dot{\theta}_{4i}(x_{5i} + x_{7i}c\delta_{6i})s\theta_{4i}(- \\
& (\dot{x}_p c(\delta_i + \delta_{3i})) - \dot{y}_p s(\delta_i + \delta_{3i}) + \dot{\phi}c(\delta_i + \delta_{3i} - \psi)(x_{16i}s(\delta_{17i} - \phi) + x_{14i}s(\delta_{15i} + \delta_{17i} - \phi)) + \dot{\psi}c\theta c(\delta_i + \\
& \delta_{3i} - \psi)(x_{16i}s(\delta_{17i} - \phi) + x_{14i}s(\delta_{15i} + \delta_{17i} - \phi)) + \dot{\psi}(x_{16i}c(\delta_{17i} - \phi) + x_{14i}c(\delta_{15i} + \delta_{17i} - \phi))s(\delta_i + \delta_{3i} - \\
& \psi) + \dot{\phi}c\theta(x_{16i}c(\delta_{17i} - \phi) + x_{14i}c(\delta_{15i} + \delta_{17i} - \phi))s(\delta_i + \delta_{3i} - \psi) + \dot{\theta}s\theta(x_{16i}s(\delta_{17i} - \phi) + x_{14i}s(\delta_{15i} + \delta_{17i} - \\
& \phi))s(\delta_i + \delta_{3i} - \psi)) - 4\dot{\psi}\dot{x}_p(x_{16i}c(\delta_{17i} - \phi) + x_{14i}c(\delta_{15i} + \delta_{17i} - \phi))s\psi - 2\dot{\phi}^2 x_{16i}c(\delta_{17i} - \phi)(y_p - x_{2i}s\delta_i) \\
& s\psi - 2\dot{\phi}^2 x_{14i}c(\delta_{15i} + \delta_{17i} - \phi)(y_p - x_{2i}s\delta_i)s\psi - 2\dot{\psi}^2(x_{16i}c(\delta_{17i} - \phi) + x_{14i}c(\delta_{15i} + \delta_{17i} - \phi))(y_p - x_{2i}s\delta_i) \\
& s\psi + 4\dot{\psi}\dot{y}_p c\theta(x_{16i}s(\delta_{17i} - \phi) + x_{14i}s(\delta_{15i} + \delta_{17i} - \phi))s\psi - 2\dot{\psi}^2 x_p c\theta(x_{16i}s(\delta_{17i} - \phi) + x_{14i}s(\delta_{15i} + \delta_{17i} - \\
& \phi))s\psi + 4\dot{\phi}(x_{16i}s(\delta_{17i} - \phi) + x_{14i}s(\delta_{15i} + \delta_{17i} - \phi))(\dot{\psi}c\psi(y_p - x_{2i}s\delta_i) + \dot{y}_p s\psi) - 2\dot{\phi}^2 x_{16i}c\theta s(\delta_{17i} - \phi) \\
& (- (y_p c\psi) + x_{7i}c(\delta_i + \delta_{3i} - \psi)s\delta_{6i} + x_{2i}s(\delta_i - \psi) + x_p s\psi) - 2\dot{\phi}^2 x_{14i}c\theta s(\delta_{15i} + \delta_{17i} - \phi) (- (y_p c\psi) + x_{7i} \\
& c(\delta_i + \delta_{3i} - \psi)s\delta_{6i} + x_{2i}s(\delta_i - \psi) + x_p s\psi) - 2\dot{\theta}^2 c\theta(x_{16i}s(\delta_{17i} - \phi) + x_{14i}s(\delta_{15i} + \delta_{17i} - \phi)) (- (y_p c\psi) + \\
& x_{7i}c(\delta_i + \delta_{3i} - \psi)s\delta_{6i} + x_{2i}s(\delta_i - \psi) + x_p s\psi) + 4\dot{\phi}c\theta(x_{16i}c(\delta_{17i} - \phi) + x_{14i}c(\delta_{15i} + \delta_{17i} - \phi))(\dot{\psi}x_{2i} \\
& c(\delta_i - \psi) + (\dot{y}_p - \dot{\psi}x_p)c\psi - \dot{\psi}x_{7i}s\delta_{6i}s(\delta_i + \delta_{3i} - \psi) - \dot{x}_p s\psi - \dot{\psi}y_p s\psi) + 4\dot{\phi}(x_{16i}s(\delta_{17i} - \phi) + x_{14i} \\
& s(\delta_{15i} + \delta_{17i} - \phi))(\dot{x}_p c\psi + \dot{\psi}(-x_p + x_{2i}c\delta_{1i})s\psi) - 4\dot{\theta}s\theta(\dot{\phi}(x_{16i}c(\delta_{17i} - \phi) + x_{14i}c(\delta_{15i} + \delta_{17i} - \phi))(y_p \\
& c\psi - x_{7i}c(\delta_i + \delta_{3i} - \psi)s\delta_{6i} - x_{2i}s(\delta_i - \psi) - x_p s\psi) + (x_{16i}s(\delta_{17i} - \phi) + x_{14i}s(\delta_{15i} + \delta_{17i} - \phi))(-(\dot{\psi}x_{2i} \\
& c(\delta_i - \psi)) + (-\dot{y}_p + \dot{\psi}x_p)c\psi + \dot{\psi}x_{7i}s\delta_{6i}s(\delta_i + \delta_{3i} - \psi) + \dot{x}_p s\psi + \dot{\psi}y_p s\psi))\psi) - 2\dot{\phi}^2 x_{16i}(x_{5i} + x_{7i} \\
& c\delta_{6i})c\theta c\theta_{4i}s(\delta_{17i} - \phi)s(\delta_i + \delta_{3i} - \psi) - 2\dot{\phi}^2 x_{14i}(x_{5i} + x_{7i}c\delta_{6i})c\theta c\theta_{4i}s(\delta_{15i} + \delta_{17i} - \phi)s(\delta_i + \delta_{3i} - \psi) - \\
& 4\dot{\phi}\dot{\psi}(x_{5i} + x_{7i}c\delta_{6i})c\theta_{4i}(x_{16i}s(\delta_{17i} - \phi) + x_{14i}s(\delta_{15i} + \delta_{17i} - \phi))s(\delta_i + \delta_{3i} - \psi) - 2\dot{\theta}^2(x_{5i} + x_{7i}c\delta_{6i})c\theta \\
& c\theta_{4i}(x_{16i}s(\delta_{17i} - \phi) + x_{14i}s(\delta_{15i} + \delta_{17i} - \phi))s(\delta_i + \delta_{3i} - \psi) - 2\dot{\psi}^2(x_{5i} + x_{7i}c\delta_{6i})c\theta c\theta_{4i}(x_{16i}s(\delta_{17i} - \phi) + \\
& x_{14i}s(\delta_{15i} + \delta_{17i} - \phi))s(\delta_i + \delta_{3i} - \psi) + 4\dot{\theta}(-x_{5i} - x_{7i}c\delta_{6i})c\theta_{4i}s\theta(-(\dot{\psi}c(\delta_i + \delta_{3i} - \psi)(x_{16i}s(\delta_{17i} - \phi) +
\end{aligned}$$

$$\begin{aligned}
 & x_{14i}s(\delta_{15i} + \delta_{17i} - \phi)) - \dot{\phi}(x_{16i}c(\delta_{17i} - \phi) + x_{14i}c(\delta_{15i} + \delta_{17i} - \phi))s(\delta_{1i} + \delta_{3i} - \psi)) + \dot{\theta}_{4i}^2(x_{5i} + x_{7i}c\delta_{6i}) \\
 & c\theta_{4i}(2x_{2i}c\delta_{3i} - 2x_p c(\delta_{1i} + \delta_{3i}) + 2(x_{16i}c(\delta_{17i} - \phi) + x_{14i}c(\delta_{15i} + \delta_{17i} - \phi))c(\delta_{1i} + \delta_{3i} - \psi) - 2y_p s(\delta_{1i} + \delta_{3i})) - \\
 & - 2c\theta(x_{16i}s(\delta_{17i} - \phi) + x_{14i}s(\delta_{15i} + \delta_{17i} - \phi))s(\delta_{1i} + \delta_{3i} - \psi)) + 4\dot{\theta}_{4i}(x_{5i} + x_{7i}c\delta_{6i})s\theta_{4i}(-(\dot{x}_p c(\delta_{1i} + \delta_{3i})) - \\
 & \dot{y}_p s(\delta_{1i} + \delta_{3i}) + \dot{\phi}c(\delta_{1i} + \delta_{3i} - \psi)(x_{16i}s(\delta_{17i} - \phi) + x_{14i}s(\delta_{15i} + \delta_{17i} - \phi)) + \dot{\psi}c\theta c(\delta_{1i} + \delta_{3i} - \psi)(x_{16i} \\
 & s(\delta_{17i} - \phi) + x_{14i}s(\delta_{15i} + \delta_{17i} - \phi)) + \dot{\psi}(x_{16i}c(\delta_{17i} - \phi) + x_{14i}c(\delta_{15i} + \delta_{17i} - \phi))s(\delta_{1i} + \delta_{3i} - \psi) + \dot{\phi}c\theta(x_{16i} \\
 & c(\delta_{17i} - \phi) + x_{14i}c(\delta_{15i} + \delta_{17i} - \phi))s(\delta_{1i} + \delta_{3i} - \psi) + \dot{\theta}s\theta(x_{16i}s(\delta_{17i} - \phi) + x_{14i}s(\delta_{15i} + \delta_{17i} - \phi))s(\delta_{1i} + \\
 & \delta_{3i} - \psi)) - 4\dot{\psi}\dot{x}_p(x_{16i}c(\delta_{17i} - \phi) + x_{14i}c(\delta_{15i} + \delta_{17i} - \phi))s\psi - 2\dot{\phi}^2 x_{16i}c(\delta_{17i} - \phi)(y_p - x_{2i}s\delta_{1i})s\psi - 2\dot{\phi}^2 \\
 & x_{14i}c(\delta_{15i} + \delta_{17i} - \phi)(y_p - x_{2i}s\delta_{1i})s\psi - 2\dot{\psi}^2(x_{16i}c(\delta_{17i} - \phi) + x_{14i}c(\delta_{15i} + \delta_{17i} - \phi))(y_p - x_{2i}s\delta_{1i})s\psi + \\
 & 4\dot{\psi}\dot{y}_p c\theta(x_{16i}s(\delta_{17i} - \phi) + x_{14i}s(\delta_{15i} + \delta_{17i} - \phi))s\psi - 2\dot{\psi}^2 x_p c\theta(x_{16i}s(\delta_{17i} - \phi) + x_{14i}s(\delta_{15i} + \delta_{17i} - \phi)) \\
 & s\psi + 4\dot{\phi}(x_{16i}s(\delta_{17i} - \phi) + x_{14i}s(\delta_{15i} + \delta_{17i} - \phi))(\dot{\psi}c\psi(y_p - x_{2i}s\delta_{1i}) + \dot{y}_p s\psi) - 2\dot{\phi}^2 x_{16i}c\theta s(\delta_{17i} - \phi) \\
 & (- (y_p c\psi) + x_{7i}c(\delta_{1i} + \delta_{3i} - \psi)s\delta_{6i} + x_{2i}s(\delta_{1i} - \psi) + x_p s\psi) - 2\dot{\phi}^2 x_{14i}c\theta s(\delta_{15i} + \delta_{17i} - \phi)(- (y_p c\psi) + x_{7i} \\
 & c(\delta_{1i} + \delta_{3i} - \psi)s\delta_{6i} + x_{2i}s(\delta_{1i} - \psi) + x_p s\psi) - 2\dot{\theta}^2 c\theta(x_{16i}s(\delta_{17i} - \phi) + x_{14i}s(\delta_{15i} + \delta_{17i} - \phi))(- (y_p c\psi) + \\
 & x_{7i}c(\delta_{1i} + \delta_{3i} - \psi)s\delta_{6i} + x_{2i}s(\delta_{1i} - \psi) + x_p s\psi) + 4\dot{\phi}c\theta(x_{16i}c(\delta_{17i} - \phi) + x_{14i}c(\delta_{15i} + \delta_{17i} - \phi))(\dot{\psi}x_{2i} \\
 & c(\delta_{1i} - \psi) + (\dot{y}_p - \dot{\psi}x_p)c\psi - \dot{\psi}x_{7i}s\delta_{6i}s(\delta_{1i} + \delta_{3i} - \psi) - \dot{x}_p s\psi - \dot{\psi}y_p s\psi) + 4\dot{\phi}(x_{16i}s(\delta_{17i} - \phi) + x_{14i} \\
 & s(\delta_{15i} + \delta_{17i} - \phi))(\dot{x}_p c\psi + \dot{\psi}(-x_p + x_{2i}c\delta_{1i})s\psi) - 4\dot{\theta}s\theta(\dot{\phi}(x_{16i}c(\delta_{17i} - \phi) + x_{14i}c(\delta_{15i} + \delta_{17i} - \phi))(y_p \\
 & c\psi - x_{7i}c(\delta_{1i} + \delta_{3i} - \psi)s\delta_{6i} - x_{2i}s(\delta_{1i} - \psi) - x_p s\psi) + (x_{16i}s(\delta_{17i} - \phi) + x_{14i}s(\delta_{15i} + \delta_{17i} - \phi))(- (\dot{\psi}x_{2i} \\
 & c(\delta_{1i} - \psi)) + (-\dot{y}_p + \dot{\psi}x_p)c\psi + \dot{\psi}x_{7i}s\delta_{6i}s(\delta_{1i} + \delta_{3i} - \psi) + \dot{x}_p s\psi + \dot{\psi}y_p s\psi)) \\
 G_{8i} &= c\theta_{8i}(- (c\delta_{6i}c\theta_{8i}s(\delta_{1i} + \delta_{3i})) + c(\delta_{1i} + \delta_{3i})(- (c\theta_{4i}c\theta_{8i}s\delta_{6i}) + s\theta_{4i}s\theta_{8i})) \\
 G_{9i} &= c\theta_{8i}(c(\delta_{1i} + \delta_{3i})c\delta_{6i}c\theta_{8i} + s(\delta_{1i} + \delta_{3i})(- (c\theta_{4i}c\theta_{8i}s\delta_{6i}) + s\theta_{4i}s\theta_{8i})) \\
 G_{10i} &= c\theta_{8i}(c\theta_{8i}s\delta_{6i}s\theta_{4i} + c\theta_{4i}s\theta_{8i}) \\
 G_{11i} &= c\theta_{8i}(x_{16i}c\delta_{17i}(c\theta c(\delta_{1i} + \delta_{3i} - \psi)(- (c\theta_{4i}c\theta_{8i}s\delta_{6i}) + s\theta_{4i}s\theta_{8i})s\phi - c\delta_{6i}c\theta_{8i}(c\phi c(\delta_{1i} + \delta_{3i} - \psi) + c\theta s\phi \\
 & s(\delta_{1i} + \delta_{3i} - \psi)) + c\phi(- (c\psi s(\delta_{1i} + \delta_{3i})s\theta_{4i}s\theta_{8i}) + c\theta_{4i}c\theta_{8i}s\delta_{6i}s(\delta_{1i} + \delta_{3i} - \psi) + c(\delta_{1i} + \delta_{3i})s\theta_{4i}s\theta_{8i} \\
 & s\psi)) + x_{14i}c(\delta_{15i} + \delta_{17i})(c\theta c(\delta_{1i} + \delta_{3i} - \psi)(- (c\theta_{4i}c\theta_{8i}s\delta_{6i}) + s\theta_{4i}s\theta_{8i})s\phi - c\delta_{6i}c\theta_{8i}(c\phi c(\delta_{1i} + \delta_{3i} - \\
 & \psi) + c\theta s\phi s(\delta_{1i} + \delta_{3i} - \psi)) + c\phi(- (c\psi s(\delta_{1i} + \delta_{3i})s\theta_{4i}s\theta_{8i}) + c\theta_{4i}c\theta_{8i}s\delta_{6i}s(\delta_{1i} + \delta_{3i} - \psi) + c(\delta_{1i} + \delta_{3i}) \\
 & s\theta_{4i}s\theta_{8i}s\psi)) + (x_{16i}s\delta_{17i} + x_{14i}s(\delta_{15i} + \delta_{17i}))(- (s\phi(c\delta_{6i}c\theta_{8i}c(\delta_{1i} + \delta_{3i} - \psi) - c\theta_{4i}c\theta_{8i}c\psi s(\delta_{1i} + \delta_{3i}) \\
 & s\delta_{6i} + s\theta_{4i}s\theta_{8i}s(\delta_{1i} + \delta_{3i} - \psi))) + c\theta c\phi(- (c(\delta_{1i} + \delta_{3i} - \psi)s\theta_{4i}s\theta_{8i}) + c\delta_{6i}c\theta_{8i}s(\delta_{1i} + \delta_{3i} - \psi) + c\theta_{4i}c\theta_{8i} \\
 & s(\delta_{1i} + \delta_{3i})s\delta_{6i}s\psi) + c(\delta_{1i} + \delta_{3i})c\theta_{4i}c\theta_{8i}s\delta_{6i}(c\theta c\phi c\psi - s\phi s\psi))) \\
 G_{12i} &= c\theta_{8i}(- (c\theta_{8i}c\phi c\psi(x_{16i}s\delta_{17i} + x_{14i}s(\delta_{15i} + \delta_{17i}))(c(\delta_{1i} + \delta_{3i})c\delta_{6i} - c\theta_{4i}s(\delta_{1i} + \delta_{3i})s\delta_{6i})s\theta) + c\theta c\theta_{8i} \\
 & c\phi(x_{16i}s\delta_{17i} + x_{14i}s(\delta_{15i} + \delta_{17i}))s\delta_{6i}s\theta_{4i} + c\theta c\theta_{4i}c\phi(x_{16i}s\delta_{17i} + x_{14i}s(\delta_{15i} + \delta_{17i}))s\theta_{8i} + (x_{16i}c\delta_{17i} + \\
 & x_{14i}c(\delta_{15i} + \delta_{17i}))c\delta_{6i}c\theta_{8i}c(\delta_{1i} + \delta_{3i} - \psi)s\theta s\phi - (x_{16i}c\delta_{17i} + x_{14i}c(\delta_{15i} + \delta_{17i}))c\theta c\theta_{8i}s\delta_{6i}s\theta_{4i}s\phi - (x_{16i} \\
 & c\delta_{17i} + x_{14i}c(\delta_{15i} + \delta_{17i}))c\theta c\theta_{4i}s\theta_{8i}s\phi + (x_{16i}c\delta_{17i} + x_{14i}c(\delta_{15i} + \delta_{17i}))c\psi s(\delta_{1i} + \delta_{3i})s\theta s\theta_{4i}s\theta_{8i}s\phi - \\
 & c\phi(x_{16i}s\delta_{17i} + x_{14i}s(\delta_{15i} + \delta_{17i}))s\theta s\theta_{4i}s\theta_{8i}s(\delta_{1i} + \delta_{3i} - \psi) - (x_{16i}c\delta_{17i} + x_{14i}c(\delta_{15i} + \delta_{17i}))c\theta_{4i}c\theta_{8i}s\delta_{6i} \\
 & s\theta s\phi s(\delta_{1i} + \delta_{3i} - \psi) - c\theta_{8i}c\phi(x_{16i}s\delta_{17i} + x_{14i}s(\delta_{15i} + \delta_{17i}))(c\delta_{6i}s(\delta_{1i} + \delta_{3i}) + c(\delta_{1i} + \delta_{3i})c\theta_{4i}s\delta_{6i})s\theta \\
 & s\psi - (x_{16i}c\delta_{17i} + x_{14i}c(\delta_{15i} + \delta_{17i}))c(\delta_{1i} + \delta_{3i})s\theta s\theta_{4i}s\theta_{8i}s\phi s\psi)
 \end{aligned}$$

Coeficientes de la ecuación (2.73)

$$\begin{aligned}
G_{13i} = & c\theta_{8i}(- (x_{16i}c\delta_{17i}(c\theta_{8i}s\delta_{6i}(c\phi s\theta s\theta_{4i} + c\theta_{4i}c(\delta_{1i} + \delta_{3i} - \psi)s\phi - c\theta c\theta_{4i}c\phi s(\delta_{1i} + \delta_{3i} - \psi)) + s\theta_{8i}(c\theta_{4i} \\
& c\phi s\theta - c(\delta_{1i} + \delta_{3i} - \psi)s\theta_{4i}s\phi + c\theta c\phi s\theta_{4i}s(\delta_{1i} + \delta_{3i} - \psi)) + c\delta_{6i}c\theta_{8i}(c\theta c\phi c(\delta_{1i} + \delta_{3i} - \psi) + s\phi s(\delta_{1i} + \\
& \delta_{3i} - \psi))) - x_{14i}c(\delta_{15i} + \delta_{17i})(c\theta_{8i}s\delta_{6i}(c\phi s\theta s\theta_{4i} + c\theta_{4i}c(\delta_{1i} + \delta_{3i} - \psi)s\phi - c\theta c\theta_{4i}c\phi s(\delta_{1i} + \delta_{3i} - \psi)) + \\
& s\theta_{8i}(c\theta_{4i}c\phi s\theta - c(\delta_{1i} + \delta_{3i} - \psi)s\theta_{4i}s\phi + c\theta c\phi s\theta_{4i}s(\delta_{1i} + \delta_{3i} - \psi)) + c\delta_{6i}c\theta_{8i}(c\theta c\phi c(\delta_{1i} + \delta_{3i} - \psi) + \\
& s\phi s(\delta_{1i} + \delta_{3i} - \psi))) + (x_{16i}s\delta_{17i} + x_{14i}s(\delta_{15i} + \delta_{17i}))(- (s\phi(c\delta_{6i}c\theta c\theta_{8i}c(\delta_{1i} + \delta_{3i} - \psi) - c\theta c\theta_{4i}c\theta_{8i}c\psi \\
& s(\delta_{1i} + \delta_{3i})s\delta_{6i} + c\theta_{8i}s\delta_{6i}s\theta s\theta_{4i} + c\theta_{4i}s\theta s\theta_{8i} + c\theta s\theta_{4i}s\theta_{8i}s(\delta_{1i} + \delta_{3i} - \psi))) + c\phi(- (c(\delta_{1i} + \delta_{3i} - \psi) \\
& s\theta_{4i}s\theta_{8i}) + c\delta_{6i}c\theta_{8i}s(\delta_{1i} + \delta_{3i} - \psi) + c\theta_{4i}c\theta_{8i}s(\delta_{1i} + \delta_{3i})s\delta_{6i}s\psi) + c(\delta_{1i} + \delta_{3i})c\theta_{4i}c\theta_{8i}s\delta_{6i}(c\phi c\psi - \\
& c\theta s\phi s\psi))) \\
G_{14i} = & 2\dot{\theta}_{4i}\dot{z}_p c\theta_{4i}c\theta_{8i}^2s\delta_{6i} + \dot{\phi}^2(- (x_{16i}c\delta_{17i}) - x_{14i}c(\delta_{15i} + \delta_{17i}))c\theta_{4i}c\theta_{8i}^2c\phi c(\delta_{1i} + \delta_{3i} - \psi)s\delta_{6i} + \dot{\psi}^2(- (x_{16i} \\
& c\delta_{17i}) - x_{14i}c(\delta_{15i} + \delta_{17i}))c\theta_{4i}c\theta_{8i}^2c\phi c(\delta_{1i} + \delta_{3i} - \psi)s\delta_{6i} + 2\dot{\theta}\dot{\theta}_{4i}c\theta c\theta_{4i}c\theta_{8i}^2c\phi(x_{16i}s\delta_{17i} + x_{14i}s(\delta_{15i} + \\
& \delta_{17i}))s\delta_{6i} - 2\dot{\theta}\dot{\psi}c\theta_{8i}^2c\phi c\psi(x_{16i}s\delta_{17i} + x_{14i}s(\delta_{15i} + \delta_{17i}))(c(\delta_{1i} + \delta_{3i})c\delta_{6i} - c\theta_{4i}s(\delta_{1i} + \delta_{3i})s\delta_{6i}) - \dot{\theta}^2 \\
& c\theta c\theta_{8i}^2c\phi c\psi(x_{16i}s\delta_{17i} + x_{14i}s(\delta_{15i} + \delta_{17i}))(c(\delta_{1i} + \delta_{3i})c\delta_{6i} - c\theta_{4i}s(\delta_{1i} + \delta_{3i})s\delta_{6i}) - \dot{\phi}^2c\theta c\theta_{8i}^2c\phi c\psi \\
& (x_{16i}s\delta_{17i} + x_{14i}s(\delta_{15i} + \delta_{17i}))(c(\delta_{1i} + \delta_{3i})c\delta_{6i} - c\theta_{4i}s(\delta_{1i} + \delta_{3i})s\delta_{6i}) - \dot{\psi}^2c\theta c\theta_{8i}^2c\phi c\psi(x_{16i}s\delta_{17i} + x_{14i} \\
& s(\delta_{15i} + \delta_{17i}))(c(\delta_{1i} + \delta_{3i})c\delta_{6i} - c\theta_{4i}s(\delta_{1i} + \delta_{3i})s\delta_{6i}) + 2\dot{\theta}_{4i}\dot{\phi}(- (x_{16i}c\delta_{17i}) - x_{14i}c(\delta_{15i} + \delta_{17i}))c\theta_{4i}c\theta_{8i}^2 \\
& c\phi s\delta_{6i}s\theta + 2\dot{\theta}_{4i}\dot{x}_p c(\delta_{1i} + \delta_{3i})c\theta_{8i}^2s\delta_{6i}s\theta_{4i} + 2\dot{\theta}_{4i}\dot{y}_p c\theta_{8i}^2s(\delta_{1i} + \delta_{3i})s\delta_{6i}s\theta_{4i} - \dot{\theta}^2c\theta_{8i}^2c\phi(x_{16i}s\delta_{17i} + x_{14i} \\
& s(\delta_{15i} + \delta_{17i}))s\delta_{6i}s\theta s\theta_{4i} - \dot{\phi}^2c\theta_{8i}^2c\phi(x_{16i}s\delta_{17i} + x_{14i}s(\delta_{15i} + \delta_{17i}))s\delta_{6i}s\theta s\theta_{4i} + x_{2i}c\delta_{3i}c\theta_{8i}^2s\delta_{6i}(- (\dot{\theta}_{4i}^2 \\
& c\theta_{4i}) - \dot{\theta}_{4i}s\theta_{4i}) - x_p c(\delta_{1i} + \delta_{3i})c\theta_{8i}^2s\delta_{6i}(- (\dot{\theta}_{4i}^2c\theta_{4i}) - \dot{\theta}_{4i}s\theta_{4i}) + (- (x_{16i}c\delta_{17i}) - x_{14i}c(\delta_{15i} + \delta_{17i}))c\theta_{8i}^2c\phi \\
& c(\delta_{1i} + \delta_{3i} - \psi)s\delta_{6i}(\dot{\theta}_{4i}^2c\theta_{4i} + \dot{\theta}_{4i}s\theta_{4i}) + y_p c\theta_{8i}^2s(\delta_{1i} + \delta_{3i})s\delta_{6i}(\dot{\theta}_{4i}^2c\theta_{4i} + \dot{\theta}_{4i}s\theta_{4i}) + z_p c\theta_{8i}^2s\delta_{6i}(\ddot{\theta}_{4i} \\
& c\theta_{4i} - \dot{\theta}_{4i}^2s\theta_{4i}) + c\theta_{8i}^2c\phi(x_{16i}s\delta_{17i} + x_{14i}s(\delta_{15i} + \delta_{17i}))s\delta_{6i}s\theta(\dot{\theta}_{4i}c\theta_{4i} - \dot{\theta}_{4i}^2s\theta_{4i}) + 2\dot{\theta}_{4i}\dot{x}_p c(\delta_{1i} + \delta_{3i})c\theta_{4i} \\
& c\theta_{8i}s\theta_{8i} + 2\dot{\theta}_{4i}\dot{y}_p c\theta_{4i}c\theta_{8i}s(\delta_{1i} + \delta_{3i})s\theta_{8i} - \dot{\theta}^2c\theta_{4i}c\theta_{8i}c\phi(x_{16i}s\delta_{17i} + x_{14i}s(\delta_{15i} + \delta_{17i}))s\theta s\theta_{8i} - \dot{\phi}^2c\theta_{4i} \\
& c\theta_{8i}c\phi(x_{16i}s\delta_{17i} + x_{14i}s(\delta_{15i} + \delta_{17i}))s\theta s\theta_{8i} - 2\dot{\theta}_{4i}\dot{z}_p c\theta_{8i}s\theta_{4i}s\theta_{8i} - \dot{\phi}^2(- (x_{16i}c\delta_{17i}) - x_{14i}c(\delta_{15i} + \delta_{17i})) \\
& c(\delta_{1i} + \delta_{3i})c\theta_{8i}c\phi c\psi s\theta_{4i}s\theta_{8i} - \dot{\psi}^2(- (x_{16i}c\delta_{17i}) - x_{14i}c(\delta_{15i} + \delta_{17i}))c(\delta_{1i} + \delta_{3i})c\theta_{8i}c\phi c\psi s\theta_{4i}s\theta_{8i} - 2\dot{\phi} \\
& \dot{\psi}(- (x_{16i}c\delta_{17i}) - x_{14i}c(\delta_{15i} + \delta_{17i}))c(\delta_{1i} + \delta_{3i})c\theta c\theta_{8i}c\phi c\psi s\theta_{4i}s\theta_{8i} + z_p c\theta_{8i}(- (\dot{\theta}_{4i}^2c\theta_{4i}) - \dot{\theta}_{4i}s\theta_{4i})s\theta_{8i} + \\
& c\theta_{8i}c\phi(x_{16i}s\delta_{17i} + x_{14i}s(\delta_{15i} + \delta_{17i}))s\theta(- (\dot{\theta}_{4i}^2c\theta_{4i}) - \dot{\theta}_{4i}s\theta_{4i})s\theta_{8i} - x_{2i}c\delta_{3i}c\theta_{8i}(\ddot{\theta}_{4i}c\theta_{4i} - \dot{\theta}_{4i}^2s\theta_{4i})s\theta_{8i} + \\
& x_p c(\delta_{1i} + \delta_{3i})c\theta_{8i}(\dot{\theta}_{4i}c\theta_{4i} - \dot{\theta}_{4i}^2s\theta_{4i})s\theta_{8i} + y_p c\theta_{8i}s(\delta_{1i} + \delta_{3i})(\dot{\theta}_{4i}c\theta_{4i} - \dot{\theta}_{4i}^2s\theta_{4i})s\theta_{8i} + 2\dot{\phi}(- (x_{16i}c\delta_{17i}) - \\
& x_{14i}c(\delta_{15i} + \delta_{17i}))c\theta_{8i}c\phi(\dot{\theta}c\theta c\theta_{4i} - \dot{\theta}_{4i}s\theta s\theta_{4i})s\theta_{8i} - \dot{\theta}^2(- (x_{16i}c\delta_{17i}) - x_{14i}c(\delta_{15i} + \delta_{17i}))c\delta_{6i}c\theta c\theta_{8i}^2 \\
& c(\delta_{1i} + \delta_{3i} - \psi)s\phi - \dot{\phi}^2(- (x_{16i}c\delta_{17i}) - x_{14i}c(\delta_{15i} + \delta_{17i}))c\delta_{6i}c\theta c\theta_{8i}^2c(\delta_{1i} + \delta_{3i} - \psi)s\phi - \dot{\psi}^2(- (x_{16i}c\delta_{17i}) - \\
& x_{14i}c(\delta_{15i} + \delta_{17i}))c\delta_{6i}c\theta c\theta_{8i}^2c(\delta_{1i} + \delta_{3i} - \psi)s\phi - \dot{\phi}^2c\theta_{8i}^2c\psi(x_{16i}s\delta_{17i} + x_{14i}s(\delta_{15i} + \delta_{17i}))(c\delta_{6i}s(\delta_{1i} + \\
& \delta_{3i}) + c(\delta_{1i} + \delta_{3i})c\theta_{4i}s\delta_{6i})s\phi - \dot{\psi}^2c\theta_{8i}^2c\psi(x_{16i}s\delta_{17i} + x_{14i}s(\delta_{15i} + \delta_{17i}))(c\delta_{6i}s(\delta_{1i} + \delta_{3i}) + c(\delta_{1i} + \delta_{3i}) \\
& c\theta_{4i}s\delta_{6i})s\phi + 2\dot{\theta}\dot{\phi}c\theta_{8i}^2c\psi(x_{16i}s\delta_{17i} + x_{14i}s(\delta_{15i} + \delta_{17i}))(c(\delta_{1i} + \delta_{3i})c\delta_{6i} - c\theta_{4i}s(\delta_{1i} + \delta_{3i})s\delta_{6i})s\theta s\phi - \\
& 2\dot{\theta}_{4i}\dot{\phi}(- (x_{16i}c\delta_{17i}) - x_{14i}c(\delta_{15i} + \delta_{17i}))c\theta_{8i}^2c(\delta_{1i} + \delta_{3i} - \psi)s\delta_{6i}s\theta_{4i}s\phi - \dot{\theta}^2(- (x_{16i}c\delta_{17i}) - x_{14i}c(\delta_{15i} + \\
& \delta_{17i}))c\theta_{8i}^2s\delta_{6i}s\theta s\theta_{4i}s\phi - \dot{\phi}^2(- (x_{16i}c\delta_{17i}) - x_{14i}c(\delta_{15i} + \delta_{17i}))c\theta_{8i}^2s\delta_{6i}s\theta s\theta_{4i}s\phi + (- (x_{16i}c\delta_{17i}) - x_{14i}
\end{aligned}$$

$$\begin{aligned}
 & c(\delta_{15i} + \delta_{17i}))c\theta_{8i}^2s\delta_{6i}s\theta(\dot{\theta}_{4i}c\theta_{4i} - \dot{\theta}_{4i}^2s\theta_{4i})s\phi - 2\dot{\phi}c\theta_{8i}^2(x_{16i}s\delta_{17i} + x_{14i}s(\delta_{15i} + \delta_{17i}))s\delta_{6i}(\dot{\theta}_{4i}c\theta_{4i}s\theta + \\
 & \dot{\theta}c\theta s\theta_{4i})s\phi - \dot{\theta}^2(-(x_{16i}c\delta_{17i}) - x_{14i}c(\delta_{15i} + \delta_{17i}))c\theta_{4i}c\theta_{8i}s\theta s\theta_{8i}s\phi - \dot{\phi}^2(-(x_{16i}c\delta_{17i}) - x_{14i}c(\delta_{15i} + \delta_{17i})) \\
 & c\theta_{4i}c\theta_{8i}s\theta s\theta_{8i}s\phi - 2\dot{\theta}\dot{\theta}_{4i}(-(x_{16i}c\delta_{17i}) - x_{14i}c(\delta_{15i} + \delta_{17i}))c\theta c\theta_{8i}s\theta_{4i}s\theta_{8i}s\phi + \dot{\phi}^2c\theta_{8i}c(\delta_{1i} + \delta_{3i} - \psi) \\
 & (x_{16i}s\delta_{17i} + x_{14i}s(\delta_{15i} + \delta_{17i}))s\theta_{4i}s\theta_{8i}s\phi + \dot{\psi}^2c\theta_{8i}c(\delta_{1i} + \delta_{3i} - \psi)(x_{16i}s\delta_{17i} + x_{14i}s(\delta_{15i} + \delta_{17i}))s\theta_{4i}s\theta_{8i} \\
 & s\phi - 2\dot{\phi}\dot{\psi}(-(x_{16i}c\delta_{17i}) - x_{14i}c(\delta_{15i} + \delta_{17i}))c\theta_{8i}c\psi s(\delta_{1i} + \delta_{3i})s\theta_{4i}s\theta_{8i}s\phi - \dot{\theta}^2(-(x_{16i}c\delta_{17i}) - x_{14i}c(\delta_{15i} + \\
 & \delta_{17i}))c\theta c\theta_{8i}c\psi s(\delta_{1i} + \delta_{3i})s\theta_{4i}s\theta_{8i}s\phi - \dot{\phi}^2(-(x_{16i}c\delta_{17i}) - x_{14i}c(\delta_{15i} + \delta_{17i}))c\theta c\theta_{8i}c\psi s(\delta_{1i} + \delta_{3i})s\theta_{4i} \\
 & s\theta_{8i}s\phi - \dot{\psi}^2(-(x_{16i}c\delta_{17i}) - x_{14i}c(\delta_{15i} + \delta_{17i}))c\theta c\theta_{8i}c\psi s(\delta_{1i} + \delta_{3i})s\theta_{4i}s\theta_{8i}s\phi + 2\dot{\theta}_{4i}\dot{\phi}c\theta_{8i}(x_{16i}s\delta_{17i} + \\
 & x_{14i}s(\delta_{15i} + \delta_{17i}))s\theta s\theta_{4i}s\theta_{8i}s\phi + (-x_{16i}c\delta_{17i}) - x_{14i}c(\delta_{15i} + \delta_{17i}))c\theta_{8i}s\theta(-\dot{\theta}_{4i}^2c\theta_{4i}) - \ddot{\theta}_{4i}s\theta_{4i})s\theta_{8i}s\phi + \\
 & 2\dot{\psi}c\theta_{8i}^2c\psi(x_{16i}s\delta_{17i} + x_{14i}s(\delta_{15i} + \delta_{17i}))(c\delta_{6i}s(\delta_{1i} + \delta_{3i}) + c(\delta_{1i} + \delta_{3i})c\theta_{4i}s\delta_{6i}) - (\dot{\theta}c\phi s\theta) - \dot{\phi}c\theta s\phi) - \\
 & 2\dot{\psi}c\theta_{8i}c(\delta_{1i} + \delta_{3i} - \psi)(x_{16i}s\delta_{17i} + x_{14i}s(\delta_{15i} + \delta_{17i}))s\theta_{4i}s\theta_{8i}(-(\dot{\theta}c\phi s\theta) - \dot{\phi}c\theta s\phi) + 2\dot{\theta}(-(x_{16i}c\delta_{17i}) - \\
 & x_{14i}c(\delta_{15i} + \delta_{17i}))c\theta c\theta_{8i}^2s\delta_{6i}(\dot{\phi}c\phi s\theta_{4i} + \dot{\theta}_{4i}c\theta_{4i}s\phi) + 2\dot{\theta}c\theta c\theta_{8i}(x_{16i}s\delta_{17i} + x_{14i}s(\delta_{15i} + \delta_{17i}))s\theta_{8i}(- \\
 & (\dot{\theta}_{4i}c\phi s\theta_{4i}) - \dot{\phi}c\theta_{4i}s\phi) - 2\dot{\psi}(-(x_{16i}c\delta_{17i}) - x_{14i}c(\delta_{15i} + \delta_{17i}))c\theta_{8i}^2c(\delta_{1i} + \delta_{3i} - \psi)(-\dot{\phi}c\theta c\theta_{4i}c\phi s\delta_{6i}) + \\
 & \dot{\phi}c\delta_{6i}s\phi + \dot{\theta}c\theta_{4i}s\delta_{6i}s\theta s\phi + \dot{\theta}_{4i}c\theta s\delta_{6i}s\theta_{4i}s\phi) + \dot{\phi}^2(-(x_{16i}c\delta_{17i}) - x_{14i}c(\delta_{15i} + \delta_{17i}))c\delta_{6i}c\theta_{8i}^2c\phi s(\delta_{1i} + \\
 & \delta_{3i} - \psi) + 2\dot{\phi}\dot{\psi}(-(x_{16i}c\delta_{17i}) - x_{14i}c(\delta_{15i} + \delta_{17i}))c\delta_{6i}c\theta c\theta_{8i}^2c\phi s(\delta_{1i} + \delta_{3i} - \psi) - 2\dot{\phi}(-(x_{16i}c\delta_{17i}) - x_{14i} \\
 & c(\delta_{15i} + \delta_{17i}))c\theta_{8i}^2c\phi s\delta_{6i}(-(\dot{\theta}c\theta_{4i}s\theta) - \dot{\theta}_{4i}c\theta s\theta_{4i})s(\delta_{1i} + \delta_{3i} - \psi) - 2\dot{\phi}\dot{\psi}c\theta_{8i}c\phi(x_{16i}s\delta_{17i} + x_{14i}s(\delta_{15i} + \\
 & \delta_{17i}))s\theta_{4i}s\theta_{8i}s(\delta_{1i} + \delta_{3i} - \psi) - \dot{\theta}^2c\theta c\theta_{8i}c\phi(x_{16i}s\delta_{17i} + x_{14i}s(\delta_{15i} + \delta_{17i}))s\theta_{4i}s\theta_{8i}s(\delta_{1i} + \delta_{3i} - \psi) - \dot{\phi}^2c\theta \\
 & c\theta_{8i}c\phi(x_{16i}s\delta_{17i} + x_{14i}s(\delta_{15i} + \delta_{17i}))s\theta_{4i}s\theta_{8i}s(\delta_{1i} + \delta_{3i} - \psi) - \dot{\psi}^2c\theta c\theta_{8i}c\phi(x_{16i}s\delta_{17i} + x_{14i}s(\delta_{15i} + \delta_{17i})) \\
 & s\theta_{4i}s\theta_{8i}s(\delta_{1i} + \delta_{3i} - \psi) + \dot{\theta}^2(-(x_{16i}c\delta_{17i}) - x_{14i}c(\delta_{15i} + \delta_{17i}))c\theta c\theta_{4i}c\theta_{8i}^2s\delta_{6i}s\phi s(\delta_{1i} + \delta_{3i} - \psi) + \dot{\phi}^2(- \\
 & (x_{16i}c\delta_{17i}) - x_{14i}c(\delta_{15i} + \delta_{17i}))c\theta c\theta_{4i}c\theta_{8i}^2s\delta_{6i}s\phi s(\delta_{1i} + \delta_{3i} - \psi) - 2\dot{\theta}\dot{\theta}_{4i}(-(x_{16i}c\delta_{17i}) - x_{14i}c(\delta_{15i} + \delta_{17i})) \\
 & c\theta_{8i}^2s\delta_{6i}s\theta s\theta_{4i}s\phi s(\delta_{1i} + \delta_{3i} - \psi) - (-x_{16i}c\delta_{17i}) - x_{14i}c(\delta_{15i} + \delta_{17i}))c\theta c\theta_{8i}^2s\delta_{6i}(-(\dot{\theta}_{4i}^2c\theta_{4i}) - \ddot{\theta}_{4i}s\theta_{4i})s\phi \\
 & s(\delta_{1i} + \delta_{3i} - \psi) + 2\dot{\theta}\dot{\phi}c\theta_{8i}(x_{16i}s\delta_{17i} + x_{14i}s(\delta_{15i} + \delta_{17i}))s\theta s\theta_{4i}s\theta_{8i}s\phi s(\delta_{1i} + \delta_{3i} - \psi) + 2\dot{\psi}(-(x_{16i}c\delta_{17i}) - \\
 & x_{14i}c(\delta_{15i} + \delta_{17i}))c\theta_{8i}^2s\delta_{6i}(\dot{\theta}_{4i}c\phi s\theta_{4i} + \dot{\phi}c\theta_{4i}s\phi)s(\delta_{1i} + \delta_{3i} - \psi) - \dot{\psi}^2(-(x_{16i}c\delta_{17i}) - x_{14i}c(\delta_{15i} + \delta_{17i})) \\
 & c\theta_{8i}^2(-c\delta_{6i}c\phi) - c\theta c\theta_{4i}s\delta_{6i}s\phi)s(\delta_{1i} + \delta_{3i} - \psi) + c\theta_{8i}(x_{16i}s\delta_{17i} + x_{14i}s(\delta_{15i} + \delta_{17i}))(\dot{\theta}_{4i}c\theta_{4i} - \dot{\theta}_{4i}^2s\theta_{4i}) \\
 & s\theta_{8i}(-c(\delta_{1i} + \delta_{3i} - \psi)s\phi) + c\theta c\phi s(\delta_{1i} + \delta_{3i} - \psi)) - 2\dot{\theta}(-(x_{16i}c\delta_{17i}) - x_{14i}c(\delta_{15i} + \delta_{17i}))c\delta_{6i}c\theta_{8i}^2s\theta(\dot{\phi} \\
 & c\phi c(\delta_{1i} + \delta_{3i} - \psi) + \dot{\psi}s\phi s(\delta_{1i} + \delta_{3i} - \psi)) + 2\dot{\theta}_{4i}c\theta_{4i}c\theta_{8i}(x_{16i}s\delta_{17i} + x_{14i}s(\delta_{15i} + \delta_{17i}))s\theta_{8i}(-(\dot{\phi}c\phi \\
 & c(\delta_{1i} + \delta_{3i} - \psi)) - \dot{\psi}c\theta c\phi c(\delta_{1i} + \delta_{3i} - \psi) - \dot{\theta}c\phi s\theta s(\delta_{1i} + \delta_{3i} - \psi) - \dot{\psi}s\phi s(\delta_{1i} + \delta_{3i} - \psi) - \dot{\phi}c\theta s\phi s(\delta_{1i} + \\
 & \delta_{3i} - \psi)) - 2\dot{\phi}\dot{\psi}c\theta_{8i}^2c\phi(x_{16i}s\delta_{17i} + x_{14i}s(\delta_{15i} + \delta_{17i}))(c\delta_{6i}s(\delta_{1i} + \delta_{3i}) + c(\delta_{1i} + \delta_{3i})c\theta_{4i}s\delta_{6i})s\psi - \dot{\theta}^2c\theta \\
 & c\theta_{8i}^2c\phi(x_{16i}s\delta_{17i} + x_{14i}s(\delta_{15i} + \delta_{17i}))(c\delta_{6i}s(\delta_{1i} + \delta_{3i}) + c(\delta_{1i} + \delta_{3i})c\theta_{4i}s\delta_{6i})s\psi - \dot{\psi}^2c\theta c\theta_{8i}^2c\phi(x_{16i} \\
 & s\delta_{17i} + x_{14i}s(\delta_{15i} + \delta_{17i}))(c\delta_{6i}s(\delta_{1i} + \delta_{3i}) + c(\delta_{1i} + \delta_{3i})c\theta_{4i}s\delta_{6i})s\psi - \dot{\psi}^2c\theta c\theta_{8i}^2c\phi(x_{16i}s\delta_{17i} + x_{14i} \\
 & s(\delta_{15i} + \delta_{17i}))(c\delta_{6i}s(\delta_{1i} + \delta_{3i}) + c(\delta_{1i} + \delta_{3i})c\theta_{4i}s\delta_{6i})s\psi - \dot{\phi}^2(-(x_{16i}c\delta_{17i}) - x_{14i}c(\delta_{15i} + \delta_{17i}))c\theta_{8i}c\phi \\
 & s(\delta_{1i} + \delta_{3i})s\theta_{4i}s\theta_{8i}s\psi - \dot{\psi}^2(-(x_{16i}c\delta_{17i}) - x_{14i}c(\delta_{15i} + \delta_{17i}))c\theta_{8i}c\phi s(\delta_{1i} + \delta_{3i})s\theta_{4i}s\theta_{8i}s\psi + \dot{\phi}^2c\theta_{8i}^2 \\
 & (x_{16i}s\delta_{17i} + x_{14i}s(\delta_{15i} + \delta_{17i}))(c(\delta_{1i} + \delta_{3i})c\delta_{6i} - c\theta_{4i}s(\delta_{1i} + \delta_{3i})s\delta_{6i})s\phi s\psi + \dot{\psi}^2c\theta_{8i}^2(x_{16i}s\delta_{17i} + x_{14i} \\
 & s(\delta_{15i} + \delta_{17i}))(c(\delta_{1i} + \delta_{3i})c\delta_{6i} - c\theta_{4i}s(\delta_{1i} + \delta_{3i})s\delta_{6i})s\phi s\psi + 2\dot{\theta}\dot{\phi}c\theta_{8i}(x_{16i}s\delta_{17i} + x_{14i}s(\delta_{15i} + \delta_{17i})) \\
 & (c\delta_{6i}s(\delta_{1i} + \delta_{3i}) + c(\delta_{1i} + \delta_{3i})c\theta_{4i}s\delta_{6i})s\theta s\phi s\psi + 2\dot{\phi}\dot{\psi}(-(x_{16i}c\delta_{17i}) - x_{14i}c(\delta_{15i} + \delta_{17i}))c(\delta_{1i} + \delta_{3i})c\theta_{8i} \\
 & s\theta_{4i}s\theta_{8i}s\phi s\psi + \dot{\theta}^2(-(x_{16i}c\delta_{17i}) - x_{14i}c(\delta_{15i} + \delta_{17i}))c(\delta_{1i} + \delta_{3i})c\theta c\theta_{8i}s\theta_{4i}s\theta_{8i}s\phi s\psi + \dot{\phi}^2(-(x_{16i}c\delta_{17i}) -
 \end{aligned}$$

$$\begin{aligned}
& x_{14i}c(\delta_{15i} + \delta_{17i}))c(\delta_{1i} + \delta_{3i})c\theta c\theta_{8i}s\theta_{4i}s\theta_{8i}s\phi s\psi + \dot{\psi}^2(-x_{16i}c\delta_{17i}) - x_{14i}c(\delta_{15i} + \delta_{17i}))c(\delta_{1i} + \delta_{3i})c\theta \\
& c\theta_{8i}s\theta_{4i}s\theta_{8i}s\phi s\psi + 2\dot{\theta}\dot{\psi}(-x_{16i}c\delta_{17i}) - x_{14i}c(\delta_{15i} + \delta_{17i}))c\theta_{8i}s(\delta_{1i} + \delta_{3i})s\theta s\theta_{4i}s\theta_{8i}s\phi s\psi - 2\dot{\psi}c\theta_{8i}^2 \\
& (x_{16i}s\delta_{17i} + x_{14i}s(\delta_{15i} + \delta_{17i}))(c(\delta_{1i} + \delta_{3i})c\delta_{6i} - c\theta_{4i}s(\delta_{1i} + \delta_{3i})s\delta_{6i}) - (\dot{\theta}c\phi s\theta) - \dot{\phi}c\theta s\phi) s\psi + 2\dot{\phi}(- \\
& (x_{16i}c\delta_{17i}) - x_{14i}c(\delta_{15i} + \delta_{17i}))c\theta_{8i}c\phi s(\delta_{1i} + \delta_{3i})s\theta_{4i}s\theta_{8i}(-\dot{\theta}c\psi s\theta) - \dot{\psi}c\theta s\psi) + (-x_{16i}c\delta_{17i}) - x_{14i} \\
& c(\delta_{15i} + \delta_{17i}))c\theta_{8i}s(\delta_{1i} + \delta_{3i})(\ddot{\theta}_{4i}c\theta_{4i} - \dot{\theta}_{4i}^2s\theta_{4i})s\theta_{8i}(c\theta c\psi s\phi + c\phi s\psi) + 2\dot{\theta}(-x_{16i}c\delta_{17i}) - x_{14i} \\
& c(\delta_{15i} + \delta_{17i}))c(\delta_{1i} + \delta_{3i})c\theta_{8i}s\theta s\theta_{4i}s\theta_{8i}(\dot{\psi}c\psi s\phi + \dot{\phi}c\phi s\psi) + c(\delta_{1i} + \delta_{3i})c\theta_{8i}^2(x_{16i}s\delta_{17i} + x_{14i} \\
& s(\delta_{15i} + \delta_{17i}))s\delta_{6i}(-(\dot{\theta}_{4i}^2c\theta_{4i}) - \dot{\theta}_{4i}s\theta_{4i})(c\psi s\phi + c\theta c\phi s\psi) + 2\dot{\theta}_{4i}c\theta_{8i}^2(x_{16i}s\delta_{17i} + x_{14i}s(\delta_{15i} + \delta_{17i})) \\
& s(\delta_{1i} + \delta_{3i})s\delta_{6i}s\theta_{4i}(-(\dot{\theta}c\phi c\psi s\theta) - \dot{\psi}c\psi s\phi - \dot{\phi}c\theta c\psi s\phi - \dot{\phi}c\phi s\psi - \dot{\psi}c\theta c\phi s\psi) + c\theta_{8i}^2(x_{16i}s\delta_{17i} + x_{4i} \\
& s(\delta_{15i} + \delta_{17i}))s(\delta_{1i} + \delta_{3i})s\delta_{6i}(\dot{\theta}_{4i}^2c\theta_{4i} + \dot{\theta}_{4i}s\theta_{4i})(c\theta c\phi c\psi - s\phi s\psi) + (-x_{16i}c\delta_{17i}) - x_{14i}c(\delta_{15i} + \delta_{17i})) \\
& c(\delta_{1i} + \delta_{3i})c\theta_{8i}(\dot{\theta}_{4i}c\theta_{4i} - \dot{\theta}_{4i}^2s\theta_{4i})s\theta_{8i}(c\phi c\psi - c\theta s\phi s\psi) - 2\dot{\theta}_{4i}c(\delta_{1i} + \delta_{3i})c\theta_{8i}^2(x_{16i}s\delta_{17i} + x_{14i}s(\delta_{15i} + \\
& \delta_{17i}))s\delta_{6i}s\theta_{4i}(\dot{\phi}c\phi c\psi + \dot{\psi}c\theta c\phi c\psi - \dot{\theta}c\phi s\theta s\psi - \dot{\psi}s\phi s\psi - \dot{\phi}c\theta s\phi s\psi) + 2\dot{\theta}_{4i}(-x_{16i}c\delta_{17i}) - x_{14i} \\
& c(\delta_{15i} + \delta_{17i}))c\theta_{4i}c\theta_{8i}s(\delta_{1i} + \delta_{3i})s\theta_{8i}(\dot{\psi}c\phi c\psi + \dot{\phi}c\theta c\phi c\psi - \dot{\theta}c\psi s\theta s\phi - \dot{\phi}s\phi s\psi - \dot{\psi}c\theta s\phi s\psi) + 2\dot{\theta}_{4i} \\
& (-x_{16i}c\delta_{17i}) - x_{14i}c(\delta_{15i} + \delta_{17i}))c(\delta_{1i} + \delta_{3i})c\theta_{4i}c\theta_{8i}s\theta_{8i}(-(\dot{\phi}c\psi s\phi) - \dot{\psi}c\theta c\psi s\phi - \dot{\psi}c\phi s\psi - \dot{\phi}c\theta c\phi \\
& s\psi + \dot{\theta}s\theta s\phi s\psi) + 2\dot{\theta}_{8i}(\dot{z}_p c\theta_{4i} - \dot{\theta}_{4i}x_{2i}c\delta_{3i}c\theta_{4i} + \dot{\theta}_{4i}x_p c(\delta_{1i} + \delta_{3i})c\theta_{4i} + \dot{\theta}_{4i}y_p c\theta_{4i}s(\delta_{1i} + \delta_{3i}) - \dot{\theta}_{4i}z_p \\
& s\theta_{4i} + \dot{x}_p c(\delta_{1i} + \delta_{3i})s\theta_{4i} + \dot{y}_p s(\delta_{1i} + \delta_{3i})s\theta_{4i} + (x_{16i}s\delta_{17i} + x_{14i}s(\delta_{15i} + \delta_{17i}))) (\dot{\theta}c\theta c\theta_{4i}c\phi - \dot{\theta}_{4i}c\phi s\theta \\
& s\theta_{4i} - \dot{\phi}c\theta_{4i}s\theta s\phi + \dot{\theta}_{4i}c\theta_{4i}(-c(\delta_{1i} + \delta_{3i} - \psi)s\phi) + c\theta c\phi s(\delta_{1i} + \delta_{3i} - \psi)) + s\theta_{4i}(-(\dot{\phi}c\phi c(\delta_{1i} + \delta_{3i} - \\
& \psi)) - \dot{\psi}c\theta c\phi c(\delta_{1i} + \delta_{3i} - \psi) - \dot{\theta}c\phi s\theta s(\delta_{1i} + \delta_{3i} - \psi) - \dot{\psi}s\phi s(\delta_{1i} + \delta_{3i} - \psi) - \dot{\phi}c\theta s\phi s(\delta_{1i} + \delta_{3i} - \psi))) + \\
& (-x_{16i}c\delta_{17i}) - x_{14i}c(\delta_{15i} + \delta_{17i}))) (\dot{\phi}c\theta_{4i}c\phi s\theta + \dot{\theta}c\theta c\theta_{4i}s\phi - \dot{\theta}_{4i}s\theta s\theta_{4i}s\phi + \dot{\theta}_{4i}c\theta_{4i}s(\delta_{1i} + \delta_{3i}))(c\theta c\psi \\
& s\phi + c\phi s\psi) + \dot{\theta}_{4i}c(\delta_{1i} + \delta_{3i})c\theta_{4i}(c\phi c\psi - c\theta s\phi s\psi) + s(\delta_{1i} + \delta_{3i})s\theta_{4i}(\dot{\psi}c\phi c\psi + \dot{\phi}c\theta c\phi c\psi - \dot{\theta}c\psi s\theta \\
& s\phi - \dot{\phi}s\phi s\psi - \dot{\psi}c\theta s\phi s\psi) + c(\delta_{1i} + \delta_{3i})s\theta_{4i}(-(\dot{\phi}c\psi s\phi) - \dot{\psi}c\theta c\psi s\phi - \dot{\psi}c\phi s\psi - \dot{\phi}c\theta c\phi s\psi + \dot{\theta}s\theta s\phi \\
& s\psi)) + \dot{\theta}_{8i}(z_p c\theta_{4i} - x_{2i}c\delta_{3i}s\theta_{4i} + x_p c(\delta_{1i} + \delta_{3i})s\theta_{4i} + y_p s(\delta_{1i} + \delta_{3i})s\theta_{4i} + (x_{16i}s\delta_{17i} + x_{14i}s(\delta_{15i} + \delta_{17i}))) \\
& (c\theta_{4i}c\phi s\theta + s\theta_{4i}(-c(\delta_{1i} + \delta_{3i} - \psi)s\phi) + c\theta c\phi s(\delta_{1i} + \delta_{3i} - \psi))) + (-x_{16i}c\delta_{17i}) - x_{14i}c(\delta_{15i} + \delta_{17i})) \\
& (c\theta_{4i}s\theta s\phi + s(\delta_{1i} + \delta_{3i})s\theta_{4i}(c\theta c\psi s\phi + c\phi s\psi) + c(\delta_{1i} + \delta_{3i})s\theta_{4i}(c\phi c\psi - c\theta s\phi s\psi))) \tan \theta_{8i}
\end{aligned}$$

Coeficientes de la ecuación (2.76)

$$\begin{aligned}
G_{15i} &= -(c\theta_{9i}(-(s(\delta_{1i} + \delta_{3i})s\delta_{6i}s\theta_{9i}) + c(\delta_{1i} + \delta_{3i})(c\theta_{9i} \sec \theta_{8i}s\theta_{4i} + c\delta_{6i}c\theta_{4i}s\theta_{9i}))) \\
G_{16i} &= -(c\theta_{9i}(c\theta_{9i} \sec \theta_{8i}s(\delta_{1i} + \delta_{3i})s\theta_{4i} + (c\delta_{6i}c\theta_{4i}s(\delta_{1i} + \delta_{3i}) + c(\delta_{1i} + \delta_{3i})s\delta_{6i})s\theta_{9i})) \\
G_{17i} &= c\theta_{9i}(-(c\theta_{4i}c\theta_{9i} \sec \theta_{8i}) + c\delta_{6i}s\theta_{4i}s\theta_{9i}) \\
G_{18i} &= c\theta_{9i}(x_{16i}c\delta_{17i}c\phi c(\delta_{1i} + \delta_{3i} - \psi)s\delta_{6i}s\theta_{9i} + x_{16i}c(\delta_{1i} + \delta_{3i})c\psi s\delta_{17i}s\delta_{6i}s\theta_{9i}s\phi + x_{14i}c(\delta_{1i} + \delta_{3i})c\psi \\
& s(\delta_{15i} + \delta_{17i})s\delta_{6i}s\theta_{9i}s\phi + x_{16i}c\delta_{17i}c\theta_{9i}c\phi \sec \theta_{8i}s\theta_{4i}s(\delta_{1i} + \delta_{3i} - \psi) + x_{16i}c\delta_{17i}c\delta_{6i}c\theta_{4i}c\phi s\theta_{9i}s(\delta_{1i} + \\
& \delta_{3i} - \psi) + x_{16i}c\theta_{9i} \sec \theta_{8i}s\delta_{17i}s\theta_{4i}s\phi s(\delta_{1i} + \delta_{3i} - \psi) + x_{14i}c\theta_{9i} \sec \theta_{8i}s(\delta_{15i} + \delta_{17i})s\theta_{4i}s\phi s(\delta_{1i} + \delta_{3i} - \\
& \psi) + x_{16i}c\delta_{6i}c\theta_{4i}s\delta_{17i}s\theta_{9i}s\phi s(\delta_{1i} + \delta_{3i} - \psi) + x_{14i}c\delta_{6i}c\theta_{4i}s(\delta_{15i} + \delta_{17i})s\theta_{9i}s\phi s(\delta_{1i} + \delta_{3i} - \psi) + x_{14i} \\
& c(\delta_{15i} + \delta_{17i})c\phi(c(\delta_{1i} + \delta_{3i} - \psi)s\delta_{6i}s\theta_{9i} + (c\theta_{9i} \sec \theta_{8i}s\theta_{4i} + c\delta_{6i}c\theta_{4i}s\theta_{9i})s(\delta_{1i} + \delta_{3i} - \psi)) + c\theta(x_{16i} \\
& s(\delta_{17i} - \phi) + x_{14i}s(\delta_{15i} + \delta_{17i} - \phi))(c\theta_{9i}c(\delta_{1i} + \delta_{3i} - \psi) \sec \theta_{8i}s\theta_{4i} + s\theta_{9i}(c\delta_{6i}c\theta_{4i}c(\delta_{1i} + \delta_{3i} - \psi) - s\delta_{6i} \\
& s(\delta_{1i} + \delta_{3i} - \psi))) + x_{16i}s\delta_{17i}s(\delta_{1i} + \delta_{3i})s\delta_{6i}s\theta_{9i}s\phi s\psi + x_{14i}s(\delta_{15i} + \delta_{17i})s(\delta_{1i} + \delta_{3i})s\delta_{6i}s\theta_{9i}s\phi s\psi)
\end{aligned}$$

$$\begin{aligned}
 & c\theta_{9i}^2 \sec \theta_{8i} (x_{16i}s\delta_{17i} + x_{14i}s(\delta_{15i} + \delta_{17i})) (\ddot{\theta}_{4i}c\theta_{4i} - \dot{\theta}_{4i}^2s\theta_{4i}) (-c(\delta_{1i} + \delta_{3i} - \psi)s\phi) + c\theta c\phi s(\delta_{1i} + \delta_{3i} - \psi) \\
 & + 2c\delta_{6i}c\theta_{9i} (x_{16i}s\delta_{17i} + x_{14i}s(\delta_{15i} + \delta_{17i})) (\dot{\theta}c\theta_{4i}s\theta + \dot{\theta}_{4i}c\theta s\theta_{4i}) s\theta_{9i} (-\dot{\psi}c\phi c(\delta_{1i} + \delta_{3i} - \psi)) - \dot{\phi} \\
 & s\phi s(\delta_{1i} + \delta_{3i} - \psi) - 2\dot{\theta}_{4i}c\theta_{4i}c\theta_{9i}^2 \sec \theta_{8i} (x_{16i}s\delta_{17i} + x_{14i}s(\delta_{15i} + \delta_{17i})) (-\dot{\phi}c\phi c(\delta_{1i} + \delta_{3i} - \psi)) - \dot{\psi}c\theta \\
 & c\phi c(\delta_{1i} + \delta_{3i} - \psi) - \dot{\theta}c\phi s\theta s(\delta_{1i} + \delta_{3i} - \psi) - \dot{\psi}s\phi s(\delta_{1i} + \delta_{3i} - \psi) - \dot{\phi}c\theta s\phi s(\delta_{1i} + \delta_{3i} - \psi) + \dot{\phi}^2 (-x_{16i} \\
 & c\delta_{17i}) - x_{14i}c(\delta_{15i} + \delta_{17i})) c\theta_{9i}^2 c\phi \sec \theta_{8i} s(\delta_{1i} + \delta_{3i}) s\theta_{4i} s\psi + \dot{\psi}^2 (-x_{16i}c\delta_{17i}) - x_{14i}c(\delta_{15i} + \delta_{17i})) c\theta_{9i}^2 c\phi \\
 & \sec \theta_{8i} s(\delta_{1i} + \delta_{3i}) s\theta_{4i} s\psi + 2\dot{\phi}\dot{\psi}c\theta_{9i}c\phi (x_{16i}s\delta_{17i} + x_{14i}s(\delta_{15i} + \delta_{17i})) s(\delta_{1i} + \delta_{3i}) s\delta_{6i} s\theta_{9i} s\psi + \dot{\theta}^2 c\theta \\
 & c\theta_{9i}c\phi (x_{16i}s\delta_{17i} + x_{14i}s(\delta_{15i} + \delta_{17i})) s(\delta_{1i} + \delta_{3i}) s\delta_{6i} s\theta_{9i} s\psi + \dot{\phi}^2 c\theta c\theta_{9i}c\phi (x_{16i}s\delta_{17i} + x_{14i}s(\delta_{15i} + \delta_{17i})) \\
 & s(\delta_{1i} + \delta_{3i}) s\delta_{6i} s\theta_{9i} s\psi + \dot{\psi}^2 c\theta c\theta_{9i}c\phi (x_{16i}s\delta_{17i} + x_{14i}s(\delta_{15i} + \delta_{17i})) s(\delta_{1i} + \delta_{3i}) s\delta_{6i} s\theta_{9i} s\psi + \dot{\phi}^2 (-x_{16i} \\
 & c\delta_{17i}) - x_{14i}c(\delta_{15i} + \delta_{17i})) c\theta_{9i}c\phi (c\delta_{6i}c\theta_{4i} s(\delta_{1i} + \delta_{3i}) + c(\delta_{1i} + \delta_{3i}) s\delta_{6i}) s\theta_{9i} s\psi + \dot{\psi}^2 (-x_{16i}c\delta_{17i}) - x_{14i} \\
 & c(\delta_{15i} + \delta_{17i})) c\theta_{9i}c\phi (c\delta_{6i}c\theta_{4i} s(\delta_{1i} + \delta_{3i}) + c(\delta_{1i} + \delta_{3i}) s\delta_{6i}) s\theta_{9i} s\psi - 2\dot{\phi}\dot{\psi} (-x_{16i}c\delta_{17i}) - x_{14i}c(\delta_{15i} + \\
 & \delta_{17i})) c(\delta_{1i} + \delta_{3i}) c\theta_{9i}^2 \sec \theta_{8i} s\theta_{4i} s\phi s\psi - \dot{\theta}^2 (-x_{16i}c\delta_{17i}) - x_{14i}c(\delta_{15i} + \delta_{17i})) c(\delta_{1i} + \delta_{3i}) c\theta c\theta_{9i}^2 \sec \theta_{8i} \\
 & s\theta_{4i} s\phi s\psi - \dot{\phi}^2 (-x_{16i}c\delta_{17i}) - x_{14i}c(\delta_{15i} + \delta_{17i})) c(\delta_{1i} + \delta_{3i}) c\theta c\theta_{9i}^2 \sec \theta_{8i} s\theta_{4i} s\phi s\psi - \dot{\psi}^2 (-x_{16i}c\delta_{17i}) - \\
 & x_{14i}c(\delta_{15i} + \delta_{17i})) c(\delta_{1i} + \delta_{3i}) c\theta c\theta_{9i}^2 \sec \theta_{8i} s\theta_{4i} s\phi s\psi - 2\dot{\theta}\dot{\psi} (-x_{16i}c\delta_{17i}) - x_{14i}c(\delta_{15i} + \delta_{17i})) c\theta_{9i}^2 \sec \theta_{8i} \\
 & s(\delta_{1i} + \delta_{3i}) s\theta s\theta_{4i} s\phi s\psi - \dot{\phi}^2 c(\delta_{1i} + \delta_{3i}) c\theta_{9i} (x_{16i}s\delta_{17i} + x_{14i}s(\delta_{15i} + \delta_{17i})) s\delta_{6i} s\theta_{9i} s\phi s\psi - \dot{\psi}^2 c(\delta_{1i} + \delta_{3i}) \\
 & c\theta_{9i} (x_{16i}s\delta_{17i} + x_{14i}s(\delta_{15i} + \delta_{17i})) s\delta_{6i} s\theta_{9i} s\phi s\psi - 2\dot{\phi}\dot{\psi} (-x_{16i}c\delta_{17i}) - x_{14i}c(\delta_{15i} + \delta_{17i})) c\theta_{9i} (c(\delta_{1i} + \delta_{3i}) \\
 & c\delta_{6i}c\theta_{4i} - s(\delta_{1i} + \delta_{3i}) s\delta_{6i}) s\theta_{9i} s\phi s\psi - \dot{\theta}^2 (-x_{16i}c\delta_{17i}) - x_{14i}c(\delta_{15i} + \delta_{17i})) c\theta c\theta_{9i} (c(\delta_{1i} + \delta_{3i}) c\delta_{6i}c\theta_{4i} - \\
 & s(\delta_{1i} + \delta_{3i}) s\delta_{6i}) s\theta_{9i} s\phi s\psi - \dot{\phi}^2 (-x_{16i}c\delta_{17i}) - x_{14i}c(\delta_{15i} + \delta_{17i})) c\theta c\theta_{9i} (c(\delta_{1i} + \delta_{3i}) c\delta_{6i}c\theta_{4i} - s(\delta_{1i} + \\
 & \delta_{3i}) s\delta_{6i}) s\theta_{9i} s\phi s\psi - \dot{\psi}^2 (-x_{16i}c\delta_{17i}) - x_{14i}c(\delta_{15i} + \delta_{17i})) c\theta c\theta_{9i} (c(\delta_{1i} + \delta_{3i}) c\delta_{6i}c\theta_{4i} - s(\delta_{1i} + \delta_{3i}) \\
 & s\delta_{6i}) s\theta_{9i} s\phi s\psi - 2\dot{\theta}\dot{\phi}c\theta_{9i} (x_{16i}s\delta_{17i} + x_{14i}s(\delta_{15i} + \delta_{17i})) s(\delta_{1i} + \delta_{3i}) s\delta_{6i} s\theta s\theta_{9i} s\phi s\psi - 2\dot{\theta}\dot{\psi} (-x_{16i}c\delta_{17i}) - x_{14i} \\
 & c(\delta_{15i} + \delta_{17i})) c\theta_{9i} (c\delta_{6i}c\theta_{4i} s(\delta_{1i} + \delta_{3i}) + c(\delta_{1i} + \delta_{3i}) s\delta_{6i}) s\theta s\theta_{9i} s\phi s\psi + 2\dot{\psi}c(\delta_{1i} + \delta_{3i}) c\theta_{9i} (x_{16i}s\delta_{17i} + \\
 & x_{14i}s(\delta_{15i} + \delta_{17i})) s\delta_{6i} s\theta_{9i} (-\dot{\theta}c\phi s\theta) - \dot{\phi}c\theta s\phi) s\psi - 2\dot{\phi} (-x_{16i}c\delta_{17i}) - x_{14i}c(\delta_{15i} + \delta_{17i})) c\theta_{9i}^2 c\phi \sec \theta_{8i} \\
 & s(\delta_{1i} + \delta_{3i}) s\theta_{4i} (-\dot{\theta}c\psi s\theta) - \dot{\psi}c\theta s\psi) - 2\dot{\phi} (-x_{16i}c\delta_{17i}) - x_{14i}c(\delta_{15i} + \delta_{17i})) c\theta_{9i}c\phi (c\delta_{6i}c\theta_{4i} s(\delta_{1i} + \\
 & \delta_{3i}) + c(\delta_{1i} + \delta_{3i}) s\delta_{6i}) s\theta_{9i} (-\dot{\theta}c\psi s\theta) - \dot{\psi}c\theta s\psi) - (-x_{16i}c\delta_{17i}) - x_{14i}c(\delta_{15i} + \delta_{17i})) c\theta_{9i}^2 \sec \theta_{8i} s(\delta_{1i} + \\
 & \delta_{3i}) (\ddot{\theta}_{4i}c\theta_{4i} - \dot{\theta}_{4i}^2s\theta_{4i}) (c\theta c\psi s\phi + c\phi s\psi) - (-x_{16i}c\delta_{17i}) - x_{14i}c(\delta_{15i} + \delta_{17i})) c\delta_{6i}c\theta_{9i} s(\delta_{1i} + \delta_{3i}) (-\dot{\theta}_{4i}^2 \\
 & c\theta_{4i}) - \ddot{\theta}_{4i}s\theta_{4i}) s\theta_{9i} (c\theta c\psi s\phi + c\phi s\psi) - 2\dot{\theta} (-x_{16i}c\delta_{17i}) - x_{14i}c(\delta_{15i} + \delta_{17i})) c(\delta_{1i} + \delta_{3i}) c\theta_{9i}^2 \sec \theta_{8i} s\theta \\
 & s\theta_{4i} (\dot{\psi}c\psi s\phi + \dot{\phi}c\phi s\psi) - 2\dot{\theta} (-x_{16i}c\delta_{17i}) - x_{14i}c(\delta_{15i} + \delta_{17i})) c\theta_{9i} (c(\delta_{1i} + \delta_{3i}) c\delta_{6i}c\theta_{4i} - s(\delta_{1i} + \delta_{3i}) \\
 & s\delta_{6i}) s\theta s\theta_{9i} (\dot{\psi}c\psi s\phi + \dot{\phi}c\phi s\psi) - (-x_{16i}c\delta_{17i}) - x_{14i}c(\delta_{15i} + \delta_{17i})) c(\delta_{1i} + \delta_{3i}) c\theta_{9i}^2 \sec \theta_{8i} (\ddot{\theta}_{4i}c\theta_{4i} - \\
 & \dot{\theta}_{4i}^2s\theta_{4i}) (c\phi c\psi - c\theta s\phi s\psi) - (-x_{16i}c\delta_{17i}) - x_{14i}c(\delta_{15i} + \delta_{17i})) c(\delta_{1i} + \delta_{3i}) c\delta_{6i}c\theta_{9i} (-\dot{\theta}_{4i}^2c\theta_{4i}) - \ddot{\theta}_{4i}s\theta_{4i}) \\
 & s\theta_{9i} (c\phi c\psi - c\theta s\phi s\psi) - 2\dot{\theta}_{4i} (-x_{16i}c\delta_{17i}) - x_{14i}c(\delta_{15i} + \delta_{17i})) c\theta_{4i}c\theta_{9i}^2 \sec \theta_{8i} s(\delta_{1i} + \delta_{3i}) (\dot{\psi}c\phi c\psi + \dot{\phi} \\
 & c\theta c\phi c\psi - \dot{\theta}c\psi s\theta s\phi - \dot{\phi}s\phi s\psi - \dot{\psi}c\theta s\phi s\psi) + 2\dot{\theta}_{4i} (-x_{16i}c\delta_{17i}) - x_{14i}c(\delta_{15i} + \delta_{17i})) c\delta_{6i}c\theta_{9i} s(\delta_{1i} + \delta_{3i}) \\
 & s\theta_{4i} s\theta_{9i} (\dot{\psi}c\phi c\psi + \dot{\phi}c\theta c\phi c\psi - \dot{\theta}c\psi s\theta s\phi - \dot{\phi}s\phi s\psi - \dot{\psi}c\theta s\phi s\psi) - 2\dot{\theta}_{4i} (-x_{16i}c\delta_{17i}) - x_{14i}c(\delta_{15i} + \\
 & \delta_{17i})) c(\delta_{1i} + \delta_{3i}) c\theta_{4i}c\theta_{9i}^2 \sec \theta_{8i} (-\dot{\phi}c\psi s\phi) - \dot{\psi}c\theta c\psi s\phi - \dot{\psi}c\phi s\psi - \dot{\phi}c\theta c\phi s\psi + \dot{\theta}s\theta s\phi s\psi) + 2\dot{\theta}_{4i} \\
 & (-x_{16i}c\delta_{17i}) - x_{14i}c(\delta_{15i} + \delta_{17i})) c(\delta_{1i} + \delta_{3i}) c\delta_{6i}c\theta_{9i} s\theta_{4i} s\theta_{9i} (-\dot{\phi}c\psi s\phi) - \dot{\psi}c\theta c\psi s\phi - \dot{\psi}c\phi s\psi - \dot{\phi}c\theta \\
 & c\phi s\psi + \dot{\theta}s\theta s\phi s\psi) + (-\dot{\theta}_{4i}z_p c\delta_{6i}c\theta_{4i}) + \dot{y}_p (c\delta_{6i}c\theta_{4i} s(\delta_{1i} + \delta_{3i}) + c(\delta_{1i} + \delta_{3i}) s\delta_{6i}) + \dot{x}_p (c(\delta_{1i} + \delta_{3i}) \\
 & c\delta_{6i}c\theta_{4i} - s(\delta_{1i} + \delta_{3i}) s\delta_{6i}) - \dot{z}_p c\delta_{6i} s\theta_{4i} + \dot{\theta}_{4i}x_{2i} c\delta_{3i} c\delta_{6i} s\theta_{4i} - \dot{\theta}_{4i}x_p c(\delta_{1i} + \delta_{3i}) c\delta_{6i} s\theta_{4i} - \dot{\theta}_{4i}y_p c\delta_{6i} s(\delta_{1i} +
 \end{aligned}$$

$$\begin{aligned}
& \delta_{3i})s\theta_{4i} + (x_{16i}s\delta_{17i} + x_{14i}s(\delta_{15i} + \delta_{17i}))(-c\delta_{6i}(\dot{\phi}c\theta_{4i}c\phi c(\delta_{1i} + \delta_{3i} - \psi) + \dot{\psi}c\theta c\theta_{4i}c\phi c(\delta_{1i} + \delta_{3i} - \psi) + \\
& \dot{\theta}_{4i}c\theta_{4i}c\phi s\theta + \dot{\theta}c\theta c\phi s\theta_{4i} - \dot{\theta}_{4i}c(\delta_{1i} + \delta_{3i} - \psi)s\theta_{4i}s\phi - \dot{\phi}s\theta s\theta_{4i}s\phi + \dot{\theta}c\theta_{4i}c\phi s\theta s(\delta_{1i} + \delta_{3i} - \psi) + \dot{\theta}_{4i}c\theta \\
& c\phi s\theta_{4i}s(\delta_{1i} + \delta_{3i} - \psi) + \dot{\psi}c\theta_{4i}s\phi s(\delta_{1i} + \delta_{3i} - \psi) + \dot{\phi}c\theta c\theta_{4i}s\phi s(\delta_{1i} + \delta_{3i} - \psi))) + c(\delta_{1i} + \delta_{3i})s\delta_{6i}(-(\dot{\theta} \\
& c\phi c\psi s\theta) - \dot{\psi}c\psi s\phi - \dot{\phi}c\theta c\psi s\phi - \dot{\phi}c\phi s\psi - \dot{\psi}c\theta c\phi s\psi) + s(\delta_{1i} + \delta_{3i})s\delta_{6i}(\dot{\phi}c\phi c\psi + \dot{\psi}c\theta c\phi c\psi - \dot{\theta}c\phi \\
& s\theta s\psi - \dot{\psi}s\phi s\psi - \dot{\phi}c\theta s\phi s\psi) + (-x_{16i}c\delta_{17i}) - x_{14i}c(\delta_{15i} + \delta_{17i}))(-(\dot{\phi}c\delta_{6i}c\phi s\theta s\theta_{4i}) - \dot{\theta}_{4i}c\delta_{6i}c\theta_{4i}s\theta \\
& s\phi - \dot{\theta}c\delta_{6i}c\theta s\theta_{4i}s\phi - \dot{\theta}_{4i}c\delta_{6i}s(\delta_{1i} + \delta_{3i})s\theta_{4i}(c\theta c\psi s\phi + c\phi s\psi) - \dot{\theta}_{4i}c(\delta_{1i} + \delta_{3i})c\delta_{6i}s\theta_{4i}(c\phi c\psi - c\theta s\phi \\
& s\psi) + (c\delta_{6i}c\theta_{4i}s(\delta_{1i} + \delta_{3i}) + c(\delta_{1i} + \delta_{3i})s\delta_{6i})(\dot{\psi}c\phi c\psi + \dot{\phi}c\theta c\phi c\psi - \dot{\theta}c\psi s\theta s\phi - \dot{\phi}s\phi s\psi - \dot{\psi}c\theta s\phi \\
& s\psi) + (c(\delta_{1i} + \delta_{3i})c\delta_{6i}c\theta_{4i} - s(\delta_{1i} + \delta_{3i})s\delta_{6i})(-\dot{\phi}c\psi s\phi) - \dot{\psi}c\theta c\psi s\phi - \dot{\psi}c\phi s\psi - \dot{\phi}c\theta c\phi s\psi + \dot{\theta}s\theta \\
& s\phi s\psi)))(-2\dot{\theta}_{9i} + \dot{\theta}_{8i}s2\theta_{9i} \tan \theta_{8i}) + (-x_{7i} - x_{5i}c\delta_{6i} - x_{2i}c\delta_{3i}c\delta_{6i}c\theta_{4i} + x_{2i}s\delta_{3i}s\delta_{6i} + y_p(c\delta_{6i}c\theta_{4i}s(\delta_{1i} + \\
& \delta_{3i}) + c(\delta_{1i} + \delta_{3i})s\delta_{6i}) + x_p(c(\delta_{1i} + \delta_{3i})c\delta_{6i}c\theta_{4i} - s(\delta_{1i} + \delta_{3i})s\delta_{6i}) - z_p c\delta_{6i}s\theta_{4i} + (x_{16i}s\delta_{17i} + x_{14i} \\
& s(\delta_{15i} + \delta_{17i})))(-c\delta_{6i}(c\phi s\theta s\theta_{4i} + c\theta_{4i}c(\delta_{1i} + \delta_{3i} - \psi)s\phi - c\theta c\theta_{4i}c\phi s(\delta_{1i} + \delta_{3i} - \psi))) + s(\delta_{1i} + \delta_{3i}) \\
& s\delta_{6i}(c\psi s\phi + c\theta c\phi s\psi) + c(\delta_{1i} + \delta_{3i})s\delta_{6i}(c\theta c\phi c\psi - s\phi s\psi) + (-x_{16i}c\delta_{17i}) - x_{14i}c(\delta_{15i} + \delta_{17i}))(- \\
& (c\delta_{6i}s\theta s\theta_{4i}s\phi) + (c\delta_{6i}c\theta_{4i}s(\delta_{1i} + \delta_{3i}) + c(\delta_{1i} + \delta_{3i})s\delta_{6i})(c\theta c\psi s\phi + c\phi s\psi) + (c(\delta_{1i} + \delta_{3i})c\delta_{6i}c\theta_{4i} - \\
& s(\delta_{1i} + \delta_{3i})s\delta_{6i})(c\phi c\psi - c\theta s\phi s\psi))) + (\dot{\theta}_{8i}^2 c\theta_{9i}s\theta_{9i} + 2\dot{\theta}_{8i}\dot{\theta}_{9i} \tan \theta_{8i} + \ddot{\theta}_{8i}c\theta_{9i}s\theta_{9i} \tan \theta_{8i} - 2\dot{\theta}_{9i}^2 \tan \theta_{9i})
\end{aligned}$$

Coeficientes de la ecuación (2.79):

$$G_{22i} = 0$$

$$G_{23i} = 0$$

$$G_{24i} = 0$$

$$\begin{aligned}
G_{25i} = & c\theta_{11i}s\theta(-s(\delta_{1i} + \delta_{3i})(s\theta_{11i}(c\delta_{6i}c\theta_{8i}c\psi + (c\theta_{4i}c\theta_{8i}s\delta_{6i} - s\theta_{4i}s\theta_{8i})s\psi) + c\theta_{11i}(c\theta_{9i}(c\psi s\delta_{6i} - c\delta_{6i} \\
& c\theta_{4i}s\psi) + s\theta_{9i}(c\delta_{6i}c\psi s\theta_{8i} + c\theta_{8i}s\theta_{4i}s\psi + c\theta_{4i}s\delta_{6i}s\theta_{8i}s\psi))) + c(\delta_{1i} + \delta_{3i})(c\psi s\theta_{11i}s\theta_{4i}s\theta_{8i} - c\theta_{11i} \\
& c\theta_{8i}c\psi s\theta_{4i}s\theta_{9i} - c\theta_{4i}c\psi s\delta_{6i}(c\theta_{8i}s\theta_{11i} + c\theta_{11i}s\theta_{8i}s\theta_{9i}) + c\theta_{11i}c\theta_{9i}s\delta_{6i}s\psi + c\delta_{6i}(c\theta_{8i}s\theta_{11i}s\psi + c\theta_{11i} \\
& (c\theta_{4i}c\theta_{9i}c\psi + s\theta_{8i}s\theta_{9i}s\psi))))
\end{aligned}$$

$$\begin{aligned}
G_{26i} = & c\theta_{11i}(-s\theta s\theta_{11i}(c\theta_{8i}s\delta_{6i}s\theta_{4i} + c\theta_{4i}s\theta_{8i})) - c\theta c\psi s\theta_{11i}(c(\delta_{1i} + \delta_{3i})c\delta_{6i}c\theta_{8i} + s(\delta_{1i} + \delta_{3i})(-c\theta_{4i}c\theta_{8i} \\
& s\delta_{6i}) + s\theta_{4i}s\theta_{8i})) + c\theta_{11i}s\theta(c\delta_{6i}c\theta_{9i}s\theta_{4i} + (c\theta_{4i}c\theta_{8i} - s\delta_{6i}s\theta_{4i}s\theta_{8i})s\theta_{9i}) - c\theta c\theta_{11i}c\psi(c(\delta_{1i} + \delta_{3i}) \\
& (c\theta_{9i}s\delta_{6i} + c\delta_{6i}s\theta_{8i}s\theta_{9i}) + s(\delta_{1i} + \delta_{3i})(c\delta_{6i}c\theta_{4i}c\theta_{9i} - (c\theta_{8i}s\theta_{4i} + c\theta_{4i}s\delta_{6i}s\theta_{8i})s\theta_{9i})) + c\theta s\theta_{11i}(- \\
& (c\delta_{6i}c\theta_{8i}s(\delta_{1i} + \delta_{3i})) + c(\delta_{1i} + \delta_{3i})(-c\theta_{4i}c\theta_{8i}s\delta_{6i}) + s\theta_{4i}s\theta_{8i}))s\psi + c\theta c\theta_{11i}(-s(\delta_{1i} + \delta_{3i})(c\theta_{9i} \\
& s\delta_{6i} + c\delta_{6i}s\theta_{8i}s\theta_{9i})) + c(\delta_{1i} + \delta_{3i})(c\delta_{6i}c\theta_{4i}c\theta_{9i} - (c\theta_{8i}s\theta_{4i} + c\theta_{4i}s\delta_{6i}s\theta_{8i})s\theta_{9i}))s\psi)
\end{aligned}$$

$$G_{27i} = 0$$

$$\begin{aligned}
G_{28i} = & -(\dot{\theta}^2 c\theta c\theta_{11i}s\theta_{11i}(c\theta_{8i}s\delta_{6i}s\theta_{4i} + c\theta_{4i}s\theta_{8i})) - 2\dot{\theta}c\theta_{11i}s\theta s\theta_{11i}(\dot{\theta}_{8i}c\theta_{4i}c\theta_{8i} + \dot{\theta}_{4i}c\theta_{4i}c\theta_{8i}s\delta_{6i} - \dot{\theta}_{4i}s\theta_{4i} \\
& s\theta_{8i} - \dot{\theta}_{8i}s\delta_{6i}s\theta_{4i}s\theta_{8i}) + c\theta c\theta_{11i}s\theta_{11i}(-2\dot{\theta}_{4i}\dot{\theta}_{8i}c\theta_{8i}s\theta_{4i} + c\theta_{8i}s\delta_{6i}(\ddot{\theta}_{4i}c\theta_{4i} - \dot{\theta}_{4i}^2 s\theta_{4i}) - 2\dot{\theta}_{4i}\dot{\theta}_{8i}c\theta_{4i}s\delta_{6i} \\
& s\theta_{8i} + (-\dot{\theta}_{4i}^2 c\theta_{4i}) - \ddot{\theta}_{4i}s\theta_{4i})s\theta_{8i} + s\delta_{6i}s\theta_{4i}(-\dot{\theta}_{8i}^2 c\theta_{8i}) - \ddot{\theta}_{8i}s\theta_{8i}) + c\theta_{4i}(\ddot{\theta}_{8i}c\theta_{8i} - \dot{\theta}_{8i}^2 s\theta_{8i})) - 2\dot{\theta}c\theta c\theta_{11i} \\
& c\psi s\theta_{11i}(-(\dot{\theta}_{8i}c\delta_{6i}(c\delta_{1i}c\delta_{3i} - s\delta_{1i}s\delta_{3i})s\theta_{8i}) + (c\delta_{3i}s\delta_{1i} + c\delta_{1i}s\delta_{3i})(\dot{\theta}_{8i}c\theta_{8i}s\theta_{4i} + \dot{\theta}_{4i}c\theta_{8i}s\delta_{6i}s\theta_{4i} + \dot{\theta}_{4i} \\
& c\theta_{4i}s\theta_{8i} + \dot{\theta}_{8i}c\theta_{4i}s\delta_{6i}s\theta_{8i})) + \dot{\theta}^2 c\theta_{11i}c\psi s\theta s\theta_{11i}(c\delta_{6i}c\theta_{8i}(c\delta_{1i}c\delta_{3i} - s\delta_{1i}s\delta_{3i}) + (c\delta_{3i}s\delta_{1i} + c\delta_{1i}s\delta_{3i}) \\
& (-c\theta_{4i}c\theta_{8i}s\delta_{6i}) + s\theta_{4i}s\theta_{8i})) + \dot{\psi}^2 c\theta_{11i}c\psi s\theta s\theta_{11i}(c\delta_{6i}c\theta_{8i}(c\delta_{1i}c\delta_{3i} - s\delta_{1i}s\delta_{3i}) + (c\delta_{3i}s\delta_{1i} + c\delta_{1i}s\delta_{3i}) \\
& (-c\theta_{4i}c\theta_{8i}s\delta_{6i}) + s\theta_{4i}s\theta_{8i})) - c\theta_{11i}c\psi s\theta s\theta_{11i}(c\delta_{6i}(c\delta_{1i}c\delta_{3i} - s\delta_{1i}s\delta_{3i}))(-\dot{\theta}_{8i}^2 c\theta_{8i}) - \ddot{\theta}_{8i}s\theta_{8i}) + (c\delta_{3i}
\end{aligned}$$

$$\begin{aligned}
& s\theta_{8i} + \dot{\theta}_{8i}c\delta_{6i}c\theta_{8i}s\theta_{9i} - \dot{\theta}_{9i}s\delta_{6i}s\theta_{9i}) + (c\delta_{1i}c\delta_{3i} - s\delta_{1i}s\delta_{3i})(-\dot{\theta}_{9i}c\theta_{8i}c\theta_{9i}s\theta_{4i} - \dot{\theta}_{4i}c\theta_{4i}c\theta_{8i}s\theta_{9i} + \dot{\theta}_{8i}s\theta_{4i} \\
& s\theta_{8i}s\theta_{9i} + c\theta_{4i}(-\dot{\theta}_{9i}c\theta_{9i}s\delta_{6i}s\theta_{8i}) - \dot{\theta}_{9i}c\delta_{6i}s\theta_{9i} - \dot{\theta}_{8i}c\theta_{8i}s\delta_{6i}s\theta_{9i}) - \dot{\theta}_{4i}s\theta_{4i}(c\delta_{6i}c\theta_{9i} - s\delta_{6i}s\theta_{8i}s\theta_{9i})) \\
& s\psi + 2\dot{\psi}c\theta_{11i}^2(\dot{\theta}c\theta((c\delta_{1i}c\delta_{3i} - s\delta_{1i}s\delta_{3i})(c\theta_{9i}s\delta_{6i} + c\delta_{6i}s\theta_{8i}s\theta_{9i}) + (c\delta_{3i}s\delta_{1i} + c\delta_{1i}s\delta_{3i})(-c\theta_{8i}s\theta_{4i} \\
& s\theta_{9i}) + c\theta_{4i}(c\delta_{6i}c\theta_{9i} - s\delta_{6i}s\theta_{8i}s\theta_{9i}))) + s\theta((c\delta_{1i}c\delta_{3i} - s\delta_{1i}s\delta_{3i})(\dot{\theta}_{9i}c\delta_{6i}c\theta_{9i}s\theta_{8i} + \dot{\theta}_{8i}c\delta_{6i}c\theta_{8i}s\theta_{9i} - \dot{\theta}_{9i} \\
& s\delta_{6i}s\theta_{9i}) + (c\delta_{3i}s\delta_{1i} + c\delta_{1i}s\delta_{3i})(-\dot{\theta}_{9i}c\theta_{8i}c\theta_{9i}s\theta_{4i} - \dot{\theta}_{4i}c\theta_{4i}c\theta_{8i}s\theta_{9i} + \dot{\theta}_{8i}s\theta_{4i}s\theta_{8i}s\theta_{9i} + c\theta_{4i}(-\dot{\theta}_{9i}c\theta_{9i} \\
& s\delta_{6i}s\theta_{8i}) - \dot{\theta}_{9i}c\delta_{6i}s\theta_{9i} - \dot{\theta}_{8i}c\theta_{8i}s\delta_{6i}s\theta_{9i}) - \dot{\theta}_{4i}s\theta_{4i}(c\delta_{6i}c\theta_{9i} - s\delta_{6i}s\theta_{8i}s\theta_{9i})))s\psi + c\theta_{11i}^2s\theta((-c\delta_{3i}s\delta_{1i}) - \\
& c\delta_{1i}s\delta_{3i})(2\dot{\theta}_{8i}\dot{\theta}_{9i}c\delta_{6i}c\theta_{8i}c\theta_{9i} + c\delta_{6i}(\ddot{\theta}_{8i}c\theta_{8i} - \dot{\theta}_{8i}^2s\theta_{8i}))s\theta_{9i} + s\delta_{6i}(-\dot{\theta}_{9i}^2c\theta_{9i}) - \ddot{\theta}_{9i}s\theta_{9i} + c\delta_{6i}s\theta_{8i}(\ddot{\theta}_{9i} \\
& c\theta_{9i} - \dot{\theta}_{9i}^2s\theta_{9i})) + (c\delta_{1i}c\delta_{3i} - s\delta_{1i}s\delta_{3i})(s\theta_{4i}(\dot{\theta}_{8i}^2c\theta_{8i} + \ddot{\theta}_{8i}s\theta_{8i}))s\theta_{9i} + 2\dot{\theta}_{8i}s\theta_{8i}(\dot{\theta}_{9i}c\theta_{9i}s\theta_{4i} + \dot{\theta}_{4i}c\theta_{4i}s\theta_{9i}) - \\
& 2\dot{\theta}_{4i}s\theta_{4i}(-\dot{\theta}_{9i}c\theta_{9i}s\delta_{6i}s\theta_{8i}) - \dot{\theta}_{9i}c\delta_{6i}s\theta_{9i} - \dot{\theta}_{8i}c\theta_{8i}s\delta_{6i}s\theta_{9i}) + (-\dot{\theta}_{4i}^2c\theta_{4i}) - \ddot{\theta}_{4i}s\theta_{4i})(c\delta_{6i}c\theta_{9i} - s\delta_{6i}s\theta_{8i} \\
& s\theta_{9i}) - c\theta_{8i}(2\dot{\theta}_{4i}\dot{\theta}_{9i}c\theta_{4i}c\theta_{9i} + (\ddot{\theta}_{4i}c\theta_{4i} - \dot{\theta}_{4i}^2s\theta_{4i}))s\theta_{9i} + s\theta_{4i}(\ddot{\theta}_{9i}c\theta_{9i} - \dot{\theta}_{9i}^2s\theta_{9i})) + c\theta_{4i}(c\delta_{6i}(-\dot{\theta}_{9i}^2c\theta_{9i}) - \\
& \ddot{\theta}_{9i}s\theta_{9i}) - s\delta_{6i}(2\dot{\theta}_{8i}\dot{\theta}_{9i}c\theta_{8i}c\theta_{9i} + (\ddot{\theta}_{8i}c\theta_{8i} - \dot{\theta}_{8i}^2s\theta_{8i}))s\theta_{9i} + s\theta_{8i}(\ddot{\theta}_{9i}c\theta_{9i} - \dot{\theta}_{9i}^2s\theta_{9i})))s\psi + 2\dot{\theta}_{11i}(-\dot{\theta}s\theta \\
& (c\theta_{8i}s\delta_{6i}s\theta_{4i} + c\theta_{4i}s\theta_{8i})) + c\theta(\dot{\theta}_{8i}c\theta_{4i}c\theta_{8i} + \dot{\theta}_{4i}c\theta_{4i}c\theta_{8i}s\delta_{6i} - \dot{\theta}_{4i}s\theta_{4i}s\theta_{8i} - \dot{\theta}_{8i}s\delta_{6i}s\theta_{4i}s\theta_{8i}) - c\psi s\theta(- \\
& (\dot{\theta}_{8i}c\delta_{6i}(c\delta_{1i}c\delta_{3i} - s\delta_{1i}s\delta_{3i}))s\theta_{8i}) + (c\delta_{3i}s\delta_{1i} + c\delta_{1i}s\delta_{3i})(\dot{\theta}_{8i}c\theta_{8i}s\theta_{4i} + \dot{\theta}_{4i}c\theta_{8i}s\delta_{6i}s\theta_{4i} + \dot{\theta}_{4i}c\theta_{4i}s\theta_{8i} + \\
& \dot{\theta}_{8i}c\theta_{4i}s\delta_{6i}s\theta_{8i})) - \dot{\theta}c\theta c\psi(c\delta_{6i}c\theta_{8i}(c\delta_{1i}c\delta_{3i} - s\delta_{1i}s\delta_{3i}) + (c\delta_{3i}s\delta_{1i} + c\delta_{1i}s\delta_{3i})(-c\theta_{4i}c\theta_{8i}s\delta_{6i}) + s\theta_{4i} \\
& s\theta_{8i})) + \dot{\psi}c\psi s\theta(c\delta_{6i}c\theta_{8i}(-c\delta_{3i}s\delta_{1i}) - c\delta_{1i}s\delta_{3i}) + (c\delta_{1i}c\delta_{3i} - s\delta_{1i}s\delta_{3i})(-c\theta_{4i}c\theta_{8i}s\delta_{6i}) + s\theta_{4i}s\theta_{8i})) + \\
& s\theta(-\dot{\theta}_{8i}c\delta_{6i}(-c\delta_{3i}s\delta_{1i}) - c\delta_{1i}s\delta_{3i})s\theta_{8i}) + (c\delta_{1i}c\delta_{3i} - s\delta_{1i}s\delta_{3i})(\dot{\theta}_{8i}c\theta_{8i}s\theta_{4i} + \dot{\theta}_{4i}c\theta_{8i}s\delta_{6i}s\theta_{4i} + \dot{\theta}_{4i}c\theta_{4i} \\
& s\theta_{8i} + \dot{\theta}_{8i}c\theta_{4i}s\delta_{6i}s\theta_{8i}))s\psi + \dot{\psi}s\theta(c\delta_{6i}c\theta_{8i}(c\delta_{1i}c\delta_{3i} - s\delta_{1i}s\delta_{3i}) + (c\delta_{3i}s\delta_{1i} + c\delta_{1i}s\delta_{3i})(-c\theta_{4i}c\theta_{8i} \\
& s\delta_{6i}) + s\theta_{4i}s\theta_{8i}))s\psi + \dot{\theta}c\theta(c\delta_{6i}c\theta_{8i}(-c\delta_{3i}s\delta_{1i}) - c\delta_{1i}s\delta_{3i}) + (c\delta_{1i}c\delta_{3i} - s\delta_{1i}s\delta_{3i})(-c\theta_{4i}c\theta_{8i}s\delta_{6i}) + \\
& s\theta_{4i}s\theta_{8i}))s\psi + \dot{\theta}_{11i}(c\theta(c\theta_{8i}s\delta_{6i}s\theta_{4i} + c\theta_{4i}s\theta_{8i}) - c\psi s\theta(c\delta_{6i}c\theta_{8i}(c\delta_{1i}c\delta_{3i} - s\delta_{1i}s\delta_{3i}) + (c\delta_{3i}s\delta_{1i} + c\delta_{1i} \\
& s\delta_{3i})(-c\theta_{4i}c\theta_{8i}s\delta_{6i}) + s\theta_{4i}s\theta_{8i})) + s\theta(c\delta_{6i}c\theta_{8i}(-c\delta_{3i}s\delta_{1i}) - c\delta_{1i}s\delta_{3i}) + (c\delta_{1i}c\delta_{3i} - s\delta_{1i}s\delta_{3i})(-c\theta_{4i} \\
& c\theta_{8i}s\delta_{6i}) + s\theta_{4i}s\theta_{8i}))s\psi) \tan \theta_{11i}
\end{aligned}$$

Coefficientes de la ecuación (2.82):

$$G_{29i} = 0$$

$$G_{30i} = 0$$

$$G_{31i} = 0$$

$$\begin{aligned}
G_{32i} = & c\theta c\theta_{13i}^2 c\phi c\psi s(\delta_{15i} + \delta_{17i})(s(\delta_{1i} + \delta_{3i})(c\delta_{6i}c\theta_{9i}s\theta_{8i} - s\delta_{6i}s\theta_{9i}) + c(\delta_{1i} + \delta_{3i})(c\theta_{8i}c\theta_{9i}s\theta_{4i} + c\theta_{4i} \\
& (c\theta_{9i}s\delta_{6i}s\theta_{8i} + c\delta_{6i}s\theta_{9i}))) + c(\delta_{15i} + \delta_{17i})c\theta c\theta_{13i}c\phi c\psi s\theta_{13i}(s(\delta_{1i} + \delta_{3i})(c\delta_{6i}c\theta_{9i}s\theta_{8i} - s\delta_{6i} \\
& s\theta_{9i}) + c(\delta_{1i} + \delta_{3i})(c\theta_{8i}c\theta_{9i}s\theta_{4i} + c\theta_{4i}(c\theta_{9i}s\delta_{6i}s\theta_{8i} + c\delta_{6i}s\theta_{9i}))) + c(\delta_{15i} + \delta_{17i})c\theta_{13i}^2 c\phi c\psi (\\
& c(\delta_{1i} + \delta_{3i})(-c\delta_{6i}c\theta_{9i}s\theta_{8i}) + s\delta_{6i}s\theta_{9i}) + s(\delta_{1i} + \delta_{3i})(c\theta_{8i}c\theta_{9i}s\theta_{4i} + c\theta_{4i}(c\theta_{9i}s\delta_{6i}s\theta_{8i} + c\delta_{6i} \\
& s\theta_{9i}))) - c\theta_{13i}c\phi c\psi s(\delta_{15i} + \delta_{17i})s\theta_{13i}(c(\delta_{1i} + \delta_{3i})(-c\delta_{6i}c\theta_{9i}s\theta_{8i}) + s\delta_{6i}s\theta_{9i}) + s(\delta_{1i} + \delta_{3i})(c\theta_{8i} \\
& c\theta_{9i}s\theta_{4i} + c\theta_{4i}(c\theta_{9i}s\delta_{6i}s\theta_{8i} + c\delta_{6i}s\theta_{9i}))) - c(\delta_{15i} + \delta_{17i})c\theta c\theta_{13i}^2 c\psi (s(\delta_{1i} + \delta_{3i})(c\delta_{6i}c\theta_{9i}s\theta_{8i} - s\delta_{6i} \\
& s\theta_{9i}) + c(\delta_{1i} + \delta_{3i})(c\theta_{8i}c\theta_{9i}s\theta_{4i} + c\theta_{4i}(c\theta_{9i}s\delta_{6i}s\theta_{8i} + c\delta_{6i}s\theta_{9i})))s\phi + c\theta c\theta_{13i}c\psi s(\delta_{15i} + \delta_{17i})s\theta_{13i} \\
& (s(\delta_{1i} + \delta_{3i})(c\delta_{6i}c\theta_{9i}s\theta_{8i} - s\delta_{6i}s\theta_{9i}) + c(\delta_{1i} + \delta_{3i})(c\theta_{8i}c\theta_{9i}s\theta_{4i} + c\theta_{4i}(c\theta_{9i}s\delta_{6i}s\theta_{8i} + c\delta_{6i}s\theta_{9i}))) \\
& s\phi + c\theta_{13i}^2 c\psi s(\delta_{15i} + \delta_{17i})(c(\delta_{1i} + \delta_{3i})(-c\delta_{6i}c\theta_{9i}s\theta_{8i}) + s\delta_{6i}s\theta_{9i}) + s(\delta_{1i} + \delta_{3i})(c\theta_{8i}c\theta_{9i}s\theta_{4i} +
\end{aligned}$$

$$\begin{aligned}
& c\theta_{9_i} + \dot{\theta}_{8_i}c\theta_{8_i}c\theta_{9_i}s\delta_{6_i} - \dot{\theta}_{9_i}s\delta_{6_i}s\theta_{8_i}s\theta_{9_i}))s\phi + (c(\delta_{1_i} + \delta_{3_i})(-\dot{\theta}_{8_i}c\delta_{6_i}c\theta_{8_i}c\theta_{9_i}) + \dot{\theta}_{9_i}c\theta_{9_i}s\delta_{6_i} + \dot{\theta}_{9_i}c\delta_{6_i}s\theta_{8_i} \\
& s\theta_{9_i}) + s(\delta_{1_i} + \delta_{3_i})(\dot{\theta}_{4_i}c\theta_{4_i}c\theta_{8_i}c\theta_{9_i} - \dot{\theta}_{8_i}c\theta_{9_i}s\theta_{4_i}s\theta_{8_i} - \dot{\theta}_{9_i}c\theta_{8_i}s\theta_{4_i}s\theta_{9_i} - \dot{\theta}_{4_i}s\theta_{4_i}(c\theta_{9_i}s\delta_{6_i}s\theta_{8_i} + c\delta_{6_i}s\theta_{9_i}) + \\
& c\theta_{4_i}(\dot{\theta}_{9_i}c\delta_{6_i}c\theta_{9_i} + \dot{\theta}_{8_i}c\theta_{8_i}c\theta_{9_i}s\delta_{6_i} - \dot{\theta}_{9_i}s\delta_{6_i}s\theta_{8_i}s\theta_{9_i}))) (c\theta c\psi s\phi + c\phi s\psi) + (s(\delta_{1_i} + \delta_{3_i})(\dot{\theta}_{8_i}c\delta_{6_i}c\theta_{8_i} \\
& c\theta_{9_i} - \dot{\theta}_{9_i}c\theta_{9_i}s\delta_{6_i} - \dot{\theta}_{9_i}c\delta_{6_i}s\theta_{8_i}s\theta_{9_i}) + c(\delta_{1_i} + \delta_{3_i})(\dot{\theta}_{4_i}c\theta_{4_i}c\theta_{8_i}c\theta_{9_i} - \dot{\theta}_{8_i}c\theta_{9_i}s\theta_{4_i}s\theta_{8_i} - \dot{\theta}_{9_i}c\theta_{8_i}s\theta_{4_i}s\theta_{9_i} - \dot{\theta}_{4_i} \\
& s\theta_{4_i}(c\theta_{9_i}s\delta_{6_i}s\theta_{8_i} + c\delta_{6_i}s\theta_{9_i}) + c\theta_{4_i}(\dot{\theta}_{9_i}c\delta_{6_i}c\theta_{9_i} + \dot{\theta}_{8_i}c\theta_{8_i}c\theta_{9_i}s\delta_{6_i} - \dot{\theta}_{9_i}s\delta_{6_i}s\theta_{8_i}s\theta_{9_i}))) (c\phi c\psi - c\theta s\phi \\
& s\psi) + (c(\delta_{1_i} + \delta_{3_i})(-c\delta_{6_i}c\theta_{9_i}s\theta_{8_i}) + s\delta_{6_i}s\theta_{9_i}) + s(\delta_{1_i} + \delta_{3_i})(c\theta_{8_i}c\theta_{9_i}s\theta_{4_i} + c\theta_{4_i}(c\theta_{9_i}s\delta_{6_i}s\theta_{8_i} + c\delta_{6_i} \\
& s\theta_{9_i}))) (\psi c\phi c\psi + \phi c\theta c\phi c\psi - \theta c\psi s\theta s\phi - \phi s\phi s\psi - \psi c\theta s\phi s\psi) + (s(\delta_{1_i} + \delta_{3_i})(c\delta_{6_i}c\theta_{9_i}s\theta_{8_i} - s\delta_{6_i} \\
& s\theta_{9_i}) + c(\delta_{1_i} + \delta_{3_i})(c\theta_{8_i}c\theta_{9_i}s\theta_{4_i} + c\theta_{4_i}(c\theta_{9_i}s\delta_{6_i}s\theta_{8_i} + c\delta_{6_i}s\theta_{9_i}))) (-\dot{\phi}c\psi s\phi) - \psi c\theta c\psi s\phi - \psi c\phi s\psi - \\
& \dot{\phi}c\theta c\phi s\psi + \dot{\theta}s\theta s\phi s\psi) + \dot{\theta}_{13_i}(c(\delta_{15_i} + \delta_{17_i})(c\phi s\theta(c\theta_{4_i}c\theta_{8_i}c\theta_{9_i} - s\theta_{4_i}(c\theta_{9_i}s\delta_{6_i}s\theta_{8_i} + c\delta_{6_i}s\theta_{9_i})) + \\
& (s(\delta_{1_i} + \delta_{3_i})(c\delta_{6_i}c\theta_{9_i}s\theta_{8_i} - s\delta_{6_i}s\theta_{9_i}) + c(\delta_{1_i} + \delta_{3_i})(c\theta_{8_i}c\theta_{9_i}s\theta_{4_i} + c\theta_{4_i}(c\theta_{9_i}s\delta_{6_i}s\theta_{8_i} + c\delta_{6_i}s\theta_{9_i}))) (- \\
& (c\psi s\phi) - c\theta c\phi s\psi) + (c(\delta_{1_i} + \delta_{3_i})(-c\delta_{6_i}c\theta_{9_i}s\theta_{8_i}) + s\delta_{6_i}s\theta_{9_i}) + s(\delta_{1_i} + \delta_{3_i})(c\theta_{8_i}c\theta_{9_i}s\theta_{4_i} + c\theta_{4_i}(c\theta_{9_i} \\
& s\delta_{6_i}s\theta_{8_i} + c\delta_{6_i}s\theta_{9_i}))) (c\theta c\phi c\psi - s\phi s\psi) + s\delta_{15_i} + \delta_{17_i}(s\theta(c\theta_{4_i}c\theta_{8_i}c\theta_{9_i} - s\theta_{4_i}(c\theta_{9_i}s\delta_{6_i}s\theta_{8_i} + c\delta_{6_i} \\
& s\theta_{9_i}))s\phi + (c(\delta_{1_i} + \delta_{3_i})(-c\delta_{6_i}c\theta_{9_i}s\theta_{8_i}) + s\delta_{6_i}s\theta_{9_i}) + s(\delta_{1_i} + \delta_{3_i})(c\theta_{8_i}c\theta_{9_i}s\theta_{4_i} + c\theta_{4_i}(c\theta_{9_i}s\delta_{6_i}s\theta_{8_i} + \\
& c\delta_{6_i}s\theta_{9_i}))) (c\theta c\psi s\phi + c\phi s\psi) + (s(\delta_{1_i} + \delta_{3_i})(c\delta_{6_i}c\theta_{9_i}s\theta_{8_i} - s\delta_{6_i}s\theta_{9_i}) + c(\delta_{1_i} + \delta_{3_i})(c\theta_{8_i}c\theta_{9_i}s\theta_{4_i} + \\
& c\theta_{4_i}(c\theta_{9_i}s\delta_{6_i}s\theta_{8_i} + c\delta_{6_i}s\theta_{9_i}))) (c\phi c\psi - c\theta s\phi s\psi)) \tan \theta_{13_i}
\end{aligned}$$

Coefficientes de la ecuación (2.85):

$$G_{36i} = 0$$

$$G_{37i} = 0$$

$$G_{38i} = 0$$

$$\begin{aligned}
G_{39i} = & -(c\theta_{12_i}^2(-c\theta c\theta_{11_i}c\phi c\psi s(\delta_{15_i} + \delta_{17_i})(s(\delta_{1_i} + \delta_{3_i})(c\delta_{6_i}c\theta_{9_i}s\theta_{8_i} - s\delta_{6_i}s\theta_{9_i}) + c(\delta_{1_i} + \\
& \delta_{3_i})(c\theta_{8_i}c\theta_{9_i}s\theta_{4_i} + c\theta_{4_i}(c\theta_{9_i}s\delta_{6_i}s\theta_{8_i} + c\delta_{6_i}s\theta_{9_i})))) - c(\delta_{15_i} + \delta_{17_i})c\theta_{11_i}c\phi c\psi(c(\delta_{1_i} + \\
& \delta_{3_i})(-c\delta_{6_i}c\theta_{9_i}s\theta_{8_i}) + s\delta_{6_i}s\theta_{9_i}) + s(\delta_{1_i} + \delta_{3_i})(c\theta_{8_i}c\theta_{9_i}s\theta_{4_i} + c\theta_{4_i}(c\theta_{9_i}s\delta_{6_i}s\theta_{8_i} + c\delta_{6_i} \\
& s\theta_{9_i}))) + c(\delta_{15_i} + \delta_{17_i})c\theta c\theta_{11_i}c\psi(s(\delta_{1_i} + \delta_{3_i})(c\delta_{6_i}c\theta_{9_i}s\theta_{8_i} - s\delta_{6_i}s\theta_{9_i}) + c(\delta_{1_i} + \delta_{3_i}) \\
& (c\theta_{8_i}c\theta_{9_i}s\theta_{4_i} + c\theta_{4_i}(c\theta_{9_i}s\delta_{6_i}s\theta_{8_i} + c\delta_{6_i}s\theta_{9_i})))s\phi - c\theta_{11_i}c\psi s(\delta_{15_i} + \delta_{17_i})(c(\delta_{1_i} + \delta_{3_i}) \\
& (-c\delta_{6_i}c\theta_{9_i}s\theta_{8_i}) + s\delta_{6_i}s\theta_{9_i}) + s(\delta_{1_i} + \delta_{3_i})(c\theta_{8_i}c\theta_{9_i}s\theta_{4_i} + c\theta_{4_i}(c\theta_{9_i}s\delta_{6_i}s\theta_{8_i} + c\delta_{6_i} \\
& s\theta_{9_i})))s\phi + c(\delta_{15_i} + \delta_{17_i})c\theta_{11_i}c\phi(s(\delta_{1_i} + \delta_{3_i})(c\delta_{6_i}c\theta_{9_i}s\theta_{8_i} - s\delta_{6_i}s\theta_{9_i}) + c(\delta_{1_i} + \delta_{3_i}) \\
& (c\theta_{8_i}c\theta_{9_i}s\theta_{4_i} + c\theta_{4_i}(c\theta_{9_i}s\delta_{6_i}s\theta_{8_i} + c\delta_{6_i}s\theta_{9_i})))s\psi - c\theta c\theta_{11_i}c\phi s(\delta_{15_i} + \delta_{17_i})(c(\delta_{1_i} + \\
& \delta_{3_i})(-c\delta_{6_i}c\theta_{9_i}s\theta_{8_i}) + s\delta_{6_i}s\theta_{9_i}) + s(\delta_{1_i} + \delta_{3_i})(c\theta_{8_i}c\theta_{9_i}s\theta_{4_i} + c\theta_{4_i}(c\theta_{9_i}s\delta_{6_i}s\theta_{8_i} + c\delta_{6_i} \\
& s\theta_{9_i})))s\psi + c\theta_{11_i}s(\delta_{15_i} + \delta_{17_i})(s(\delta_{1_i} + \delta_{3_i})(c\delta_{6_i}c\theta_{9_i}s\theta_{8_i} - s\delta_{6_i}s\theta_{9_i}) + c(\delta_{1_i} + \delta_{3_i}) \\
& (c\theta_{8_i}c\theta_{9_i}s\theta_{4_i} + c\theta_{4_i}(c\theta_{9_i}s\delta_{6_i}s\theta_{8_i} + c\delta_{6_i}s\theta_{9_i})))s\phi s\psi + c(\delta_{15_i} + \delta_{17_i})c\theta c\theta_{11_i}(c(\delta_{1_i} + \\
& \delta_{3_i})(-c\delta_{6_i}c\theta_{9_i}s\theta_{8_i}) + s\delta_{6_i}s\theta_{9_i}) + s(\delta_{1_i} + \delta_{3_i})(c\theta_{8_i}c\theta_{9_i}s\theta_{4_i} + c\theta_{4_i}(c\theta_{9_i}s\delta_{6_i}s\theta_{8_i} + c\delta_{6_i} \\
& s\theta_{9_i})))s\phi s\psi - c\theta c\phi c\psi s(\delta_{15_i} + \delta_{17_i})(c\delta_{6_i}c\theta_{8_i}s(\delta_{1_i} + \delta_{3_i}) + c(\delta_{1_i} + \delta_{3_i})(c\theta_{4_i}c\theta_{8_i} \\
& s\delta_{6_i} - s\theta_{4_i}s\theta_{8_i})) \tan \theta_{12_i} + c(\delta_{15_i} + \delta_{17_i})c\phi c\psi(c(\delta_{1_i} + \delta_{3_i})c\delta_{6_i}c\theta_{8_i} + s(\delta_{1_i} + \delta_{3_i})(- \\
& (c\theta_{4_i}c\theta_{8_i}s\delta_{6_i}) + s\theta_{4_i}s\theta_{8_i})) \tan \theta_{12_i} - c(\delta_{15_i} + \delta_{17_i})c\theta c\psi(-c\delta_{6_i}c\theta_{8_i}s(\delta_{1_i} + \delta_{3_i})) + \\
& c(\delta_{1_i} + \delta_{3_i})(-(c\theta_{4_i}c\theta_{8_i}s\delta_{6_i}) + s\theta_{4_i}s\theta_{8_i}))s\phi \tan \theta_{12_i} + c\psi s(\delta_{15_i} + \delta_{17_i})(c(\delta_{1_i} + \delta_{3_i})
\end{aligned}$$

$$\begin{aligned}
& \delta_{3i})) + c(\delta_{1i} + \delta_{3i})(-(c\theta_{4i}c\theta_{8i}s\delta_{6i}) + s\theta_{4i}s\theta_{8i}))s\phi \tan \theta_{12i} + c\theta c\psi s(\delta_{15i} + \delta_{17i}) \\
& (c(\delta_{1i} + \delta_{3i})c\delta_{6i}c\theta_{8i} + s(\delta_{1i} + \delta_{3i})(-(c\theta_{4i}c\theta_{8i}s\delta_{6i}) + s\theta_{4i}s\theta_{8i}))s\phi \tan \theta_{12i} - c(\delta_{15i} + \\
& \delta_{17i})c\theta c\phi(-(c\delta_{6i}c\theta_{8i}s(\delta_{1i} + \delta_{3i})) + c(\delta_{1i} + \delta_{3i})(-(c\theta_{4i}c\theta_{8i}s\delta_{6i}) + s\theta_{4i}s\theta_{8i}))s\psi \\
& \tan \theta_{12i} + c\phi s(\delta_{15i} + \delta_{17i})(c(\delta_{1i} + \delta_{3i})c\delta_{6i}c\theta_{8i} + s(\delta_{1i} + \delta_{3i})(-(c\theta_{4i}c\theta_{8i}s\delta_{6i}) + s\theta_{4i} \\
& s\theta_{8i}))s\psi \tan \theta_{12i} + c\theta s(\delta_{15i} + \delta_{17i})(c\delta_{6i}c\theta_{8i}s(\delta_{1i} + \delta_{3i}) + c(\delta_{1i} + \delta_{3i})(c\theta_{4i}c\theta_{8i}s\delta_{6i} - \\
& s\theta_{4i}s\theta_{8i}))s\phi s\psi \tan \theta_{12i} - c(\delta_{15i} + \delta_{17i})(c(\delta_{1i} + \delta_{3i})c\delta_{6i}c\theta_{8i} + s(\delta_{1i} + \delta_{3i})(-(c\theta_{4i}c\theta_{8i} \\
& s\delta_{6i}) + s\theta_{4i}s\theta_{8i}))s\phi s\psi \tan \theta_{12i})) \\
G_{42i} = & -(c\theta_{12i}^2(-2\dot{\theta}_{11i}\dot{\theta}_{12i}c\theta_{11i}c\theta_{13i} \sec \theta_{12i}^2 + 2\dot{\theta}_{12i}\dot{\theta}_{13i} \sec \theta_{12i}^2 s\theta_{11i}s\theta_{13i} - \dot{\theta}^2 c\theta_{11i}c\phi s(\delta_{15i} + \delta_{17i}) \\
& s\theta(c\theta_{4i}c\theta_{8i}c\theta_{9i} - s\theta_{4i}(c\theta_{9i}s\delta_{6i}s\theta_{8i} + c\delta_{6i}s\theta_{9i}))) - \dot{\phi}^2 c\theta_{11i}c\phi s(\delta_{15i} + \delta_{17i})s\theta(c\theta_{4i}c\theta_{8i} \\
& c\theta_{9i} - s\theta_{4i}(c\theta_{9i}s\delta_{6i}s\theta_{8i} + c\delta_{6i}s\theta_{9i})) + c\theta_{11i}c\phi s(\delta_{15i} + \delta_{17i})s\theta(c\theta_{9i}(c\theta_{8i}(-(\dot{\theta}_{4i}^2 c\theta_{4i}) - \\
& \ddot{\theta}_{4i}s\theta_{4i}) + 2\dot{\theta}_{4i}\dot{\theta}_{8i}s\theta_{4i}s\theta_{8i} + c\theta_{4i}(-(\dot{\theta}_{8i}^2 c\theta_{8i}) - \ddot{\theta}_{8i}s\theta_{8i}))) - 2\dot{\theta}_{9i}(-(\dot{\theta}_{4i}c\theta_{8i}s\theta_{4i}) - \dot{\theta}_{8i}c\theta_{4i} \\
& s\theta_{8i})s\theta_{9i} + c\theta_{4i}c\theta_{8i}(-(\dot{\theta}_{9i}^2 c\theta_{9i}) - \ddot{\theta}_{9i}s\theta_{9i})) + (-(\ddot{\theta}_{4i}c\theta_{4i}) + \dot{\theta}_{4i}^2 s\theta_{4i})(c\theta_{9i}s\delta_{6i}s\theta_{8i} + c\delta_{6i} \\
& s\theta_{9i}) - 2\dot{\theta}_{4i}c\theta_{4i}(\dot{\theta}_{9i}c\delta_{6i}c\theta_{9i} + \dot{\theta}_{8i}c\theta_{8i}c\theta_{9i}s\delta_{6i} - \dot{\theta}_{9i}s\delta_{6i}s\theta_{8i}s\theta_{9i}) - s\theta_{4i}(c\theta_{9i}s\delta_{6i}(\ddot{\theta}_{8i} \\
& c\theta_{8i} - \dot{\theta}_{8i}^2 s\theta_{8i}) - 2\dot{\theta}_{8i}\dot{\theta}_{9i}c\theta_{8i}s\delta_{6i}s\theta_{9i} + s\delta_{6i}s\theta_{8i}(-(\dot{\theta}_{9i}^2 c\theta_{9i}) - \ddot{\theta}_{9i}s\theta_{9i})) + c\delta_{6i}(\ddot{\theta}_{9i}c\theta_{9i} - \\
& \dot{\theta}_{9i}^2 s\theta_{9i})) + \dot{\phi}^2 c(\delta_{15i} + \delta_{17i})c\theta_{11i}c\phi c\psi (s(\delta_{1i} + \delta_{3i})(c\delta_{6i}c\theta_{9i}s\theta_{8i} - s\delta_{6i}s\theta_{9i})) + c(\delta_{1i} + \\
& \delta_{3i})(c\theta_{8i}c\theta_{9i}s\theta_{4i} + c\theta_{4i}(c\theta_{9i}s\delta_{6i}s\theta_{8i} + c\delta_{6i}s\theta_{9i}))) + \dot{\psi}^2 c(\delta_{15i} + \delta_{17i})c\theta_{11i}c\phi c\psi (\\
& s(\delta_{1i} + \delta_{3i})(c\delta_{6i}c\theta_{9i}s\theta_{8i} - s\delta_{6i}s\theta_{9i})) + c(\delta_{1i} + \delta_{3i})(c\theta_{8i}c\theta_{9i}s\theta_{4i} + c\theta_{4i}(c\theta_{9i}s\delta_{6i}s\theta_{8i} + \\
& c\delta_{6i}s\theta_{9i}))) + 2\dot{\phi}\dot{\psi}c(\delta_{15i} + \delta_{17i})c\theta c\theta_{11i}c\phi c\psi (s(\delta_{1i} + \delta_{3i})(c\delta_{6i}c\theta_{9i}s\theta_{8i} - s\delta_{6i}s\theta_{9i})) + \\
& c(\delta_{1i} + \delta_{3i})(c\theta_{8i}c\theta_{9i}s\theta_{4i} + c\theta_{4i}(c\theta_{9i}s\delta_{6i}s\theta_{8i} + c\delta_{6i}s\theta_{9i}))) - 2\dot{\phi}\dot{\psi}c\theta_{11i}c\phi c\psi s(\delta_{15i} + \\
& \delta_{17i})(c(\delta_{1i} + \delta_{3i})(-(c\delta_{6i}c\theta_{9i}s\theta_{8i}) + s\delta_{6i}s\theta_{9i})) + s(\delta_{1i} + \delta_{3i})(c\theta_{8i}c\theta_{9i}s\theta_{4i} + c\theta_{4i}(c\theta_{9i} \\
& s\delta_{6i}s\theta_{8i} + c\delta_{6i}s\theta_{9i}))) - \dot{\theta}^2 c\theta c\theta_{11i}c\phi c\psi s(\delta_{15i} + \delta_{17i})(c(\delta_{1i} + \delta_{3i})(-(c\delta_{6i}c\theta_{9i}s\theta_{8i}) + \\
& s\delta_{6i}s\theta_{9i})) + s(\delta_{1i} + \delta_{3i})(c\theta_{8i}c\theta_{9i}s\theta_{4i} + c\theta_{4i}(c\theta_{9i}s\delta_{6i}s\theta_{8i} + c\delta_{6i}s\theta_{9i}))) - \dot{\phi}^2 c\theta c\theta_{11i}c\phi \\
& c\psi s(\delta_{15i} + \delta_{17i})(c(\delta_{1i} + \delta_{3i})(-(c\delta_{6i}c\theta_{9i}s\theta_{8i}) + s\delta_{6i}s\theta_{9i})) + s(\delta_{1i} + \delta_{3i})(c\theta_{8i}c\theta_{9i} \\
& s\theta_{4i} + c\theta_{4i}(c\theta_{9i}s\delta_{6i}s\theta_{8i} + c\delta_{6i}s\theta_{9i}))) - \dot{\psi}^2 c\theta c\theta_{11i}c\phi c\psi s(\delta_{15i} + \delta_{17i})(c(\delta_{1i} + \delta_{3i})(-(\\
& c\delta_{6i}c\theta_{9i}s\theta_{8i}) + s\delta_{6i}s\theta_{9i})) + s(\delta_{1i} + \delta_{3i})(c\theta_{8i}c\theta_{9i}s\theta_{4i} + c\theta_{4i}(c\theta_{9i}s\delta_{6i}s\theta_{8i} + c\delta_{6i} \\
& s\theta_{9i}))) - 2\dot{\phi}c(\delta_{15i} + \delta_{17i})c\theta_{11i}c\phi(\dot{\theta}c\theta(c\theta_{4i}c\theta_{8i}c\theta_{9i} - s\theta_{4i}(c\theta_{9i}s\delta_{6i}s\theta_{8i} + c\delta_{6i}s\theta_{9i}))) + \\
& s\theta(-(\dot{\theta}_{4i}c\theta_{8i}c\theta_{9i}s\theta_{4i}) - \dot{\theta}_{8i}c\theta_{4i}c\theta_{9i}s\theta_{8i} - \dot{\theta}_{9i}c\theta_{4i}c\theta_{8i}s\theta_{9i} - \dot{\theta}_{4i}c\theta_{4i}(c\theta_{9i}s\delta_{6i}s\theta_{8i} + c\delta_{6i} \\
& s\theta_{9i}) - s\theta_{4i}(\dot{\theta}_{9i}c\delta_{6i}c\theta_{9i} + \dot{\theta}_{8i}c\theta_{8i}c\theta_{9i}s\delta_{6i} - \dot{\theta}_{9i}s\delta_{6i}s\theta_{8i}s\theta_{9i}))) - 2\dot{\theta}\dot{\phi}c\theta c\theta_{11i}c\phi s(\delta_{15i} + \delta_{17i}) \\
& (c\theta_{4i}c\theta_{8i}c\theta_{9i} - s\theta_{4i}(c\theta_{9i}s\delta_{6i}s\theta_{8i} + c\delta_{6i}s\theta_{9i}))s\phi + \dot{\theta}^2 c(\delta_{15i} + \delta_{17i})c\theta_{11i}s\theta(c\theta_{4i}c\theta_{8i} \\
& c\theta_{9i} - s\theta_{4i}(c\theta_{9i}s\delta_{6i}s\theta_{8i} + c\delta_{6i}s\theta_{9i}))s\phi + \dot{\phi}^2 c(\delta_{15i} + \delta_{17i})c\theta_{11i}s\theta(c\theta_{4i}c\theta_{8i}c\theta_{9i} - s\theta_{4i} \\
& (c\theta_{9i}s\delta_{6i}s\theta_{8i} + c\delta_{6i}s\theta_{9i}))s\phi - 2\dot{\theta}c(\delta_{15i} + \delta_{17i})c\theta c\theta_{11i}(-(\dot{\theta}_{4i}c\theta_{8i}c\theta_{9i}s\theta_{4i}) - \dot{\theta}_{8i}c\theta_{4i}c\theta_{9i} \\
& s\theta_{8i} - \dot{\theta}_{9i}c\theta_{4i}c\theta_{8i}s\theta_{9i} - \dot{\theta}_{4i}c\theta_{4i}(c\theta_{9i}s\delta_{6i}s\theta_{8i} + c\delta_{6i}s\theta_{9i}) - s\theta_{4i}(\dot{\theta}_{9i}c\delta_{6i}c\theta_{9i} + \dot{\theta}_{8i}c\theta_{8i}c\theta_{9i} \\
& s\delta_{6i} - \dot{\theta}_{9i}s\delta_{6i}s\theta_{8i}s\theta_{9i}))s\phi - c(\delta_{15i} + \delta_{17i})c\theta_{11i}s\theta(c\theta_{9i}(c\theta_{8i}(-(\dot{\theta}_{4i}^2 c\theta_{4i}) - \ddot{\theta}_{4i}s\theta_{4i}) + \\
& 2\dot{\theta}_{4i}\dot{\theta}_{8i}s\theta_{4i}s\theta_{8i} + c\theta_{4i}(-(\dot{\theta}_{8i}^2 c\theta_{8i}) - \ddot{\theta}_{8i}s\theta_{8i}))) - 2\dot{\theta}_{9i}(-(\dot{\theta}_{4i}c\theta_{8i}s\theta_{4i}) - \dot{\theta}_{8i}c\theta_{4i}s\theta_{8i})s\theta_{9i} + \\
& c\theta_{4i}c\theta_{8i}(-(\dot{\theta}_{9i}^2 c\theta_{9i}) - \ddot{\theta}_{9i}s\theta_{9i})) + (-(\ddot{\theta}_{4i}c\theta_{4i}) + \dot{\theta}_{4i}^2 s\theta_{4i})(c\theta_{9i}s\delta_{6i}s\theta_{8i} + c\delta_{6i}s\theta_{9i}) - 2\dot{\theta}_{4i} \\
& c\theta_{4i}(\dot{\theta}_{9i}c\delta_{6i}c\theta_{9i} + \dot{\theta}_{8i}c\theta_{8i}c\theta_{9i}s\delta_{6i} - \dot{\theta}_{9i}s\delta_{6i}s\theta_{8i}s\theta_{9i}) - s\theta_{4i}(c\theta_{9i}s\delta_{6i}(\ddot{\theta}_{8i}c\theta_{8i} - \dot{\theta}_{8i}^2 s\theta_{8i}) -
\end{aligned}$$

$$\begin{aligned}
& c\theta_{4i}) - \ddot{\theta}_{4i}s\theta_{4i})(c\theta_{9i}s\delta_{6i}s\theta_{8i} + c\delta_{6i}s\theta_{9i}) + 2\dot{\theta}_{4i}c\theta_{4i}(-(\dot{\theta}_{8i}c\theta_{9i}s\theta_{8i}) - \dot{\theta}_{9i}c\theta_{8i}s\theta_{9i}) - 2\dot{\theta}_{4i} \\
& s\theta_{4i}(\dot{\theta}_{9i}c\delta_{6i}c\theta_{9i} + \dot{\theta}_{8i}c\theta_{8i}c\theta_{9i}s\delta_{6i} - \dot{\theta}_{9i}s\delta_{6i}s\theta_{8i}s\theta_{9i}) + s\theta_{4i}(c\theta_{9i}(-(\dot{\theta}_{8i}^2c\theta_{8i}) - \ddot{\theta}_{8i}s\theta_{8i})) + \\
& 2\dot{\theta}_{8i}\dot{\theta}_{9i}s\theta_{8i}s\theta_{9i} + c\theta_{8i}(-(\dot{\theta}_{9i}^2c\theta_{9i}) - \ddot{\theta}_{9i}s\theta_{9i})) + c\theta_{4i}(c\theta_{9i}s\delta_{6i}(\ddot{\theta}_{8i}c\theta_{8i} - \dot{\theta}_{8i}^2s\theta_{8i}) - 2\dot{\theta}_{8i} \\
& \dot{\theta}_{9i}c\theta_{8i}s\delta_{6i}s\theta_{9i} + s\delta_{6i}s\theta_{8i}(-(\dot{\theta}_{9i}^2c\theta_{9i}) - \ddot{\theta}_{9i}s\theta_{9i}) + c\delta_{6i}(\ddot{\theta}_{9i}c\theta_{9i} - \dot{\theta}_{9i}^2s\theta_{9i}))) (c\phi c\psi - \\
& c\theta s\phi s\psi) + 2c\theta_{11i}s(\delta_{15i} + \delta_{17i})(s(\delta_{1i} + \delta_{3i})(\dot{\theta}_{8i}c\delta_{6i}c\theta_{8i}c\theta_{9i} - \dot{\theta}_{9i}c\theta_{9i}s\delta_{6i} - \dot{\theta}_{8i}c\delta_{6i} \\
& s\theta_{8i}s\theta_{9i}) + c(\delta_{1i} + \delta_{3i})(\dot{\theta}_{4i}c\theta_{4i}c\theta_{8i}c\theta_{9i} - \dot{\theta}_{8i}c\theta_{9i}s\theta_{4i}s\theta_{8i} - \dot{\theta}_{9i}c\theta_{8i}s\theta_{4i}s\theta_{9i} - \dot{\theta}_{4i}s\theta_{4i} \\
& (c\theta_{9i}s\delta_{6i}s\theta_{8i} + c\delta_{6i}s\theta_{9i})) + c\theta_{4i}(\dot{\theta}_{9i}c\delta_{6i}c\theta_{9i} + \dot{\theta}_{8i}c\theta_{8i}c\theta_{9i}s\delta_{6i} - \dot{\theta}_{9i}s\delta_{6i}s\theta_{8i}s\theta_{9i})) (- \\
& (\dot{\phi}c\phi c\psi) - \dot{\psi}c\theta c\phi c\psi + \dot{\theta}c\phi s\theta s\psi + \dot{\psi}s\phi s\psi + \dot{\phi}c\theta s\phi s\psi) - 2c(\delta_{15i} + \delta_{17i})c\theta_{11i} \\
& (c(\delta_{1i} + \delta_{3i})(-\dot{\theta}_{8i}c\delta_{6i}c\theta_{8i}c\theta_{9i}) + \dot{\theta}_{9i}c\theta_{9i}s\delta_{6i} + \dot{\theta}_{8i}c\delta_{6i}s\theta_{8i}s\theta_{9i}) + s(\delta_{1i} + \delta_{3i})(\dot{\theta}_{4i} \\
& c\theta_{4i}c\theta_{8i}c\theta_{9i} - \dot{\theta}_{8i}c\theta_{9i}s\theta_{4i}s\theta_{8i} - \dot{\theta}_{9i}c\theta_{8i}s\theta_{4i}s\theta_{9i} - \dot{\theta}_{4i}s\theta_{4i}(c\theta_{9i}s\delta_{6i}s\theta_{8i} + c\delta_{6i}s\theta_{9i})) + c\theta_{4i} \\
& (\dot{\theta}_{9i}c\delta_{6i}c\theta_{9i} + \dot{\theta}_{8i}c\theta_{8i}c\theta_{9i}s\delta_{6i} - \dot{\theta}_{9i}s\delta_{6i}s\theta_{8i}s\theta_{9i}))) (\dot{\psi}c\phi c\psi + \dot{\phi}c\theta c\phi c\psi - \dot{\theta}c\psi s\theta s\phi - \\
& \dot{\phi}s\phi s\psi - \dot{\psi}c\theta s\phi s\psi) - 2c(\delta_{15i} + \delta_{17i})c\theta_{11i}(s(\delta_{1i} + \delta_{3i})(\dot{\theta}_{8i}c\delta_{6i}c\theta_{8i}c\theta_{9i} - \dot{\theta}_{9i}c\theta_{9i}s\delta_{6i} - \\
& \dot{\theta}_{8i}c\delta_{6i}s\theta_{8i}s\theta_{9i}) + c(\delta_{1i} + \delta_{3i})(\dot{\theta}_{4i}c\theta_{4i}c\theta_{8i}c\theta_{9i} - \dot{\theta}_{8i}c\theta_{9i}s\theta_{4i}s\theta_{8i} - \dot{\theta}_{9i}c\theta_{8i}s\theta_{4i}s\theta_{9i} - \dot{\theta}_{4i} \\
& s\theta_{4i}(c\theta_{9i}s\delta_{6i}s\theta_{8i} + c\delta_{6i}s\theta_{9i})) + c\theta_{4i}(\dot{\theta}_{9i}c\delta_{6i}c\theta_{9i} + \dot{\theta}_{8i}c\theta_{8i}c\theta_{9i}s\delta_{6i} - \dot{\theta}_{9i}s\delta_{6i}s\theta_{8i}s\theta_{9i}))) \\
& (-\dot{\phi}c\psi s\phi) - \dot{\psi}c\theta c\psi s\phi - \dot{\psi}c\phi s\psi - \dot{\phi}c\theta c\phi s\psi + \dot{\theta}s\theta s\phi s\psi) + (\dot{\theta}_{11i}^2c\theta_{11i} + \ddot{\theta}_{11i}s\theta_{11i}) \\
& (-s(\delta_{15i} + \delta_{17i})(c\phi s\theta(c\theta_{4i}c\theta_{8i}c\theta_{9i} - s\theta_{4i}(c\theta_{9i}s\delta_{6i}s\theta_{8i} + c\delta_{6i}s\theta_{9i}))) + s(\delta_{1i} + \delta_{3i}) \\
& (c\delta_{6i}c\theta_{9i}s\theta_{8i} - s\delta_{6i}s\theta_{9i})) + c(\delta_{1i} + \delta_{3i})(c\theta_{8i}c\theta_{9i}s\theta_{4i} + c\theta_{4i}(c\theta_{9i}s\delta_{6i}s\theta_{8i} + c\delta_{6i}s\theta_{9i}))) \\
& (-c\psi s\phi) - c\theta c\phi s\psi) + (c(\delta_{1i} + \delta_{3i})(-c\delta_{6i}c\theta_{9i}s\theta_{8i}) + s\delta_{6i}s\theta_{9i}) + s(\delta_{1i} + \delta_{3i})(c\theta_{8i} \\
& c\theta_{9i}s\theta_{4i} + c\theta_{4i}(c\theta_{9i}s\delta_{6i}s\theta_{8i} + c\delta_{6i}s\theta_{9i}))) (c\theta c\phi c\psi - s\phi s\psi)) + c(\delta_{15i} + \delta_{17i})(s\theta(\\
& c\theta_{4i}c\theta_{8i}c\theta_{9i} - s\theta_{4i}(c\theta_{9i}s\delta_{6i}s\theta_{8i} + c\delta_{6i}s\theta_{9i}))s\phi + c(\delta_{1i} + \delta_{3i})(-c\delta_{6i}c\theta_{9i}s\theta_{8i}) + s\delta_{6i} \\
& s\theta_{9i}) + s(\delta_{1i} + \delta_{3i})(c\theta_{8i}c\theta_{9i}s\theta_{4i} + c\theta_{4i}(c\theta_{9i}s\delta_{6i}s\theta_{8i} + c\delta_{6i}s\theta_{9i}))) (c\theta c\psi s\phi + c\phi \\
& s\psi) + (s(\delta_{1i} + \delta_{3i})(c\delta_{6i}c\theta_{9i}s\theta_{8i} - s\delta_{6i}s\theta_{9i}) + c(\delta_{1i} + \delta_{3i})(c\theta_{8i}c\theta_{9i}s\theta_{4i} + c\theta_{4i}(c\theta_{9i} \\
& s\delta_{6i}s\theta_{8i} + c\delta_{6i}s\theta_{9i}))) (c\phi c\psi - c\theta s\phi s\psi)) + 2\dot{\theta}_{12i} \sec^2(-s(\delta_{15i} + \delta_{17i})(\dot{\theta}c\theta c\phi \\
& (c\theta_{8i}s\delta_{6i}s\theta_{4i} + c\theta_{4i}s\theta_{8i})) + c\phi s\theta(\dot{\theta}_{8i}c\theta_{4i}c\theta_{8i} + \dot{\theta}_{4i}c\theta_{4i}c\theta_{8i}s\delta_{6i} - \dot{\theta}_{4i}s\theta_{4i}s\theta_{8i} - \dot{\theta}_{8i}s\delta_{6i} \\
& s\theta_{4i}s\theta_{8i}) - \dot{\phi}s\theta(c\theta_{8i}s\delta_{6i}s\theta_{4i} + c\theta_{4i}s\theta_{8i}))s\phi + (-\dot{\theta}_{8i}c\delta_{6i}s(\delta_{1i} + \delta_{3i})s\theta_{8i}) + c(\delta_{1i} + \\
& \delta_{3i})(-\dot{\theta}_{8i}c\theta_{8i}s\theta_{4i}) - \dot{\theta}_{4i}c\theta_{8i}s\delta_{6i}s\theta_{4i} - \dot{\theta}_{4i}c\theta_{4i}s\theta_{8i} - \dot{\theta}_{8i}c\theta_{4i}s\delta_{6i}s\theta_{8i})) (c\psi s\phi + c\theta c\phi \\
& s\psi) + (c(\delta_{1i} + \delta_{3i})c\delta_{6i}c\theta_{8i} + s(\delta_{1i} + \delta_{3i})(-c\theta_{4i}c\theta_{8i}s\delta_{6i}) + s\theta_{4i}s\theta_{8i})) (-\dot{\theta}c\phi c\psi \\
& s\theta) - \dot{\psi}c\psi s\phi - \dot{\phi}c\theta c\psi s\phi - \dot{\phi}c\phi s\psi - \dot{\psi}c\theta c\phi s\psi) + (-\dot{\theta}_{8i}c(\delta_{1i} + \delta_{3i})c\delta_{6i}s\theta_{8i}) + \\
& s(\delta_{1i} + \delta_{3i})(\dot{\theta}_{8i}c\theta_{8i}s\theta_{4i} + \dot{\theta}_{4i}c\theta_{8i}s\delta_{6i}s\theta_{4i} + \dot{\theta}_{4i}c\theta_{4i}s\theta_{8i} + \dot{\theta}_{8i}c\theta_{4i}s\delta_{6i}s\theta_{8i})) (c\theta c\phi c\psi - \\
& s\phi s\psi) + (c\delta_{6i}c\theta_{8i}s(\delta_{1i} + \delta_{3i}) + c(\delta_{1i} + \delta_{3i})(c\theta_{4i}c\theta_{8i}s\delta_{6i} - s\theta_{4i}s\theta_{8i})) (\dot{\phi}c\phi c\psi + \dot{\psi} \\
& c\theta c\phi c\psi - \dot{\theta}c\phi s\theta s\psi - \dot{\psi}s\phi s\psi - \dot{\phi}c\theta s\phi s\psi)) + c(\delta_{15i} + \delta_{17i})(\dot{\phi}c\phi s\theta(c\theta_{8i}s\delta_{6i}s\theta_{4i} + \\
& c\theta_{4i}s\theta_{8i}) + \dot{\theta}c\theta(c\theta_{8i}s\delta_{6i}s\theta_{4i} + c\theta_{4i}s\theta_{8i}))s\phi + s\theta(\dot{\theta}_{8i}c\theta_{4i}c\theta_{8i} + \dot{\theta}_{4i}c\theta_{4i}c\theta_{8i}s\delta_{6i} - \dot{\theta}_{4i}s\theta_{4i}
\end{aligned}$$

$$\begin{aligned}
 & s\theta_{8i} - \dot{\theta}_{8i}s\delta_{6i}s\theta_{4i}s\theta_{8i})s\phi + (-\dot{\theta}_{8i}c(\delta_{1i} + \delta_{3i})c\delta_{6i}s\theta_{8i}) + s(\delta_{1i} + \delta_{3i})(\dot{\theta}_{8i}c\theta_{8i}s\theta_{4i} + \dot{\theta}_{4i} \\
 & c\theta_{8i}s\delta_{6i}s\theta_{4i} + \dot{\theta}_{4i}c\theta_{4i}s\theta_{8i} + \dot{\theta}_{8i}c\theta_{4i}s\delta_{6i}s\theta_{8i})) (c\theta c\psi s\phi + c\phi s\psi) + (\dot{\theta}_{8i}c\delta_{6i}s(\delta_{1i} + \delta_{3i}) \\
 & s\theta_{8i} + c(\delta_{1i} + \delta_{3i})(\dot{\theta}_{8i}c\theta_{8i}s\theta_{4i} + \dot{\theta}_{4i}c\theta_{8i}s\delta_{6i}s\theta_{4i} + \dot{\theta}_{4i}c\theta_{4i}s\theta_{8i} + \dot{\theta}_{8i}c\theta_{4i}s\delta_{6i}s\theta_{8i})) (c\phi \\
 & c\psi - c\theta s\phi s\psi) + (c(\delta_{1i} + \delta_{3i})c\delta_{6i}c\theta_{8i} + s(\delta_{1i} + \delta_{3i})(-c\theta_{4i}c\theta_{8i}s\delta_{6i}) + s\theta_{4i}s\theta_{8i})) (\psi \\
 & c\phi c\psi + \dot{\phi}c\theta c\phi c\psi - \dot{\theta}c\psi s\theta s\phi - \dot{\phi}s\phi s\psi - \dot{\psi}c\theta s\phi s\psi) + (-c\delta_{6i}c\theta_{8i}s(\delta_{1i} + \delta_{3i})) + \\
 & c(\delta_{1i} + \delta_{3i})(-c\theta_{4i}c\theta_{8i}s\delta_{6i}) + s\theta_{4i}s\theta_{8i})) (-\dot{\phi}c\psi s\phi) - \dot{\psi}c\theta c\psi s\phi - \dot{\psi}c\phi s\psi - \dot{\phi}c\theta c\phi \\
 & s\psi + \dot{\theta}s\theta s\phi s\psi)) + 2\dot{\theta}_{11i}s\theta_{11i}(-s(\delta_{15i} + \delta_{17i})(\dot{\theta}c\theta c\phi(c\theta_{4i}c\theta_{8i}c\theta_{9i} - s\theta_{4i}(c\theta_{9i}s\delta_{6i} \\
 & s\theta_{8i} + c\delta_{6i}s\theta_{9i})) + c\phi s\theta(-(\dot{\theta}_{4i}c\theta_{8i}c\theta_{9i}s\theta_{4i}) - \dot{\theta}_{8i}c\theta_{4i}c\theta_{9i}s\theta_{8i} - \dot{\theta}_{9i}c\theta_{4i}c\theta_{8i}s\theta_{9i} - \dot{\theta}_{4i}c\theta_{4i} \\
 & (c\theta_{9i}s\delta_{6i}s\theta_{8i} + c\delta_{6i}s\theta_{9i}) - s\theta_{4i}(\dot{\theta}_{9i}c\delta_{6i}c\theta_{9i} + \dot{\theta}_{8i}c\theta_{8i}c\theta_{9i}s\delta_{6i} - \dot{\theta}_{9i}s\delta_{6i}s\theta_{8i}s\theta_{9i}))) - \dot{\phi}s\theta \\
 & (c\theta_{4i}c\theta_{8i}c\theta_{9i} - s\theta_{4i}(c\theta_{9i}s\delta_{6i}s\theta_{8i} + c\delta_{6i}s\theta_{9i}))s\phi + (s(\delta_{1i} + \delta_{3i})(\dot{\theta}_{8i}c\delta_{6i}c\theta_{8i}c\theta_{9i} - \dot{\theta}_{9i} \\
 & c\theta_{9i}s\delta_{6i} - \dot{\theta}_{9i}c\delta_{6i}s\theta_{8i}s\theta_{9i}) + c(\delta_{1i} + \delta_{3i})(\dot{\theta}_{4i}c\theta_{4i}c\theta_{8i}c\theta_{9i} - \dot{\theta}_{8i}c\theta_{9i}s\theta_{4i}s\theta_{8i} - \dot{\theta}_{9i}c\theta_{8i}s\theta_{4i} \\
 & s\theta_{9i} - \dot{\theta}_{4i}s\theta_{4i}(c\theta_{9i}s\delta_{6i}s\theta_{8i} + c\delta_{6i}s\theta_{9i}) + c\theta_{4i}(\dot{\theta}_{9i}c\delta_{6i}c\theta_{9i} + \dot{\theta}_{8i}c\theta_{8i}c\theta_{9i}s\delta_{6i} - \dot{\theta}_{9i}s\delta_{6i}s\theta_{8i} \\
 & s\theta_{9i}))) (-c\psi s\phi) - c\theta c\phi s\psi) + (c(\delta_{1i} + \delta_{3i})(-c\delta_{6i}c\theta_{9i}s\theta_{8i}) + s\delta_{6i}s\theta_{9i}) + s(\delta_{1i} + \\
 & \delta_{3i})(c\theta_{8i}c\theta_{9i}s\theta_{4i} + c\theta_{4i}(c\theta_{9i}s\delta_{6i}s\theta_{8i} + c\delta_{6i}s\theta_{9i}))) (-\dot{\theta}c\phi c\psi s\theta) - \dot{\psi}c\psi s\phi - \dot{\phi}c\theta c\psi \\
 & s\phi - \dot{\phi}c\phi s\psi - \dot{\psi}c\theta c\phi s\psi) + (c(\delta_{1i} + \delta_{3i})(-\dot{\theta}_{8i}c\delta_{6i}c\theta_{8i}c\theta_{9i}) + \dot{\theta}_{9i}c\theta_{9i}s\delta_{6i} + \dot{\theta}_{9i}c\delta_{6i} \\
 & s\theta_{8i}s\theta_{9i}) + s(\delta_{1i} + \delta_{3i})(\dot{\theta}_{4i}c\theta_{4i}c\theta_{8i}c\theta_{9i} - \dot{\theta}_{8i}c\theta_{9i}s\theta_{4i}s\theta_{8i} - \dot{\theta}_{9i}c\theta_{8i}s\theta_{4i}s\theta_{9i} - \dot{\theta}_{4i}s\theta_{4i}(c\theta_{9i} \\
 & s\delta_{6i}s\theta_{8i} + c\delta_{6i}s\theta_{9i})) + c\theta_{4i}(\dot{\theta}_{9i}c\delta_{6i}c\theta_{9i} + \dot{\theta}_{8i}c\theta_{8i}c\theta_{9i}s\delta_{6i} - \dot{\theta}_{9i}s\delta_{6i}s\theta_{8i}s\theta_{9i}))) (c\theta c\phi \\
 & c\psi - s\phi s\psi) + (s(\delta_{1i} + \delta_{3i})(c\delta_{6i}c\theta_{9i}s\theta_{8i} - s\delta_{6i}s\theta_{9i}) + c(\delta_{1i} + \delta_{3i})(c\theta_{8i}c\theta_{9i}s\theta_{4i} + c\theta_{4i} \\
 & (c\theta_{9i}s\delta_{6i}s\theta_{8i} + c\delta_{6i}s\theta_{9i}))) (-\dot{\phi}c\phi c\psi) - \dot{\psi}c\theta c\phi c\psi + \dot{\theta}c\phi s\theta s\psi + \dot{\psi}s\phi s\psi + \dot{\phi}c\theta s\phi \\
 & s\psi)) + c(\delta_{15i} + \delta_{17i})(\dot{\phi}c\phi s\theta(c\theta_{4i}c\theta_{8i}c\theta_{9i} - s\theta_{4i}(c\theta_{9i}s\delta_{6i}s\theta_{8i} + c\delta_{6i}s\theta_{9i})) + \dot{\theta}c\theta \\
 & (c\theta_{4i}c\theta_{8i}c\theta_{9i} - s\theta_{4i}(c\theta_{9i}s\delta_{6i}s\theta_{8i} + c\delta_{6i}s\theta_{9i}))s\phi + s\theta(-(\dot{\theta}_{4i}c\theta_{8i}c\theta_{9i}s\theta_{4i}) - \dot{\theta}_{8i}c\theta_{4i}c\theta_{9i} \\
 & s\theta_{8i} - \dot{\theta}_{9i}c\theta_{4i}c\theta_{8i}s\theta_{9i} - \dot{\theta}_{4i}c\theta_{4i}(c\theta_{9i}s\delta_{6i}s\theta_{8i} + c\delta_{6i}s\theta_{9i}) - s\theta_{4i}(\dot{\theta}_{9i}c\delta_{6i}c\theta_{9i} + \dot{\theta}_{8i}c\theta_{8i}c\theta_{9i} \\
 & s\delta_{6i} - \dot{\theta}_{9i}s\delta_{6i}s\theta_{8i}s\theta_{9i})))s\phi + (c(\delta_{1i} + \delta_{3i})(-\dot{\theta}_{8i}c\delta_{6i}c\theta_{8i}c\theta_{9i}) + \dot{\theta}_{9i}c\theta_{9i}s\delta_{6i} + \dot{\theta}_{9i}c\delta_{6i}s\theta_{8i} \\
 & s\theta_{9i}) + s(\delta_{1i} + \delta_{3i})(\dot{\theta}_{4i}c\theta_{4i}c\theta_{8i}c\theta_{9i} - \dot{\theta}_{8i}c\theta_{9i}s\theta_{4i}s\theta_{8i} - \dot{\theta}_{9i}c\theta_{8i}s\theta_{4i}s\theta_{9i} - \dot{\theta}_{4i}s\theta_{4i}(c\theta_{9i}s\delta_{6i} \\
 & s\theta_{8i} + c\delta_{6i}s\theta_{9i})) + c\theta_{4i}(\dot{\theta}_{9i}c\delta_{6i}c\theta_{9i} + \dot{\theta}_{8i}c\theta_{8i}c\theta_{9i}s\delta_{6i} - \dot{\theta}_{9i}s\delta_{6i}s\theta_{8i}s\theta_{9i}))) (c\theta c\psi s\phi + c\phi \\
 & s\psi) + (s(\delta_{1i} + \delta_{3i})(\dot{\theta}_{8i}c\delta_{6i}c\theta_{8i}c\theta_{9i} - \dot{\theta}_{9i}c\theta_{9i}s\delta_{6i} - \dot{\theta}_{9i}c\delta_{6i}s\theta_{8i}s\theta_{9i}) + c(\delta_{1i} + \delta_{3i})(\dot{\theta}_{4i} \\
 & c\theta_{4i}c\theta_{8i}c\theta_{9i} - \dot{\theta}_{8i}c\theta_{9i}s\theta_{4i}s\theta_{8i} - \dot{\theta}_{9i}c\theta_{8i}s\theta_{4i}s\theta_{9i} - \dot{\theta}_{4i}s\theta_{4i}(c\theta_{9i}s\delta_{6i}s\theta_{8i} + c\delta_{6i}s\theta_{9i})) + c\theta_{4i} \\
 & (\dot{\theta}_{9i}c\delta_{6i}c\theta_{9i} + \dot{\theta}_{8i}c\theta_{8i}c\theta_{9i}s\delta_{6i} - \dot{\theta}_{9i}s\delta_{6i}s\theta_{8i}s\theta_{9i}))) (c\phi c\psi - c\theta s\phi s\psi) + (c(\delta_{1i} + \delta_{3i})(- \\
 & (c\delta_{6i}c\theta_{9i}s\theta_{8i}) + s\delta_{6i}s\theta_{9i}) + s(\delta_{1i} + \delta_{3i})(c\theta_{8i}c\theta_{9i}s\theta_{4i} + c\theta_{4i}(c\theta_{9i}s\delta_{6i}s\theta_{8i} + c\delta_{6i}s\theta_{9i}))) \\
 & (\dot{\psi}c\phi c\psi + \dot{\phi}c\theta c\phi c\psi - \dot{\theta}c\psi s\theta s\phi - \dot{\phi}s\phi s\psi - \dot{\psi}c\theta s\phi s\psi) + (s(\delta_{1i} + \delta_{3i})(c\delta_{6i}c\theta_{9i} \\
 & s\theta_{8i} - s\delta_{6i}s\theta_{9i}) + c(\delta_{1i} + \delta_{3i})(c\theta_{8i}c\theta_{9i}s\theta_{4i} + c\theta_{4i}(c\theta_{9i}s\delta_{6i}s\theta_{8i} + c\delta_{6i}s\theta_{9i}))) (-\dot{\phi}c\psi \\
 & s\phi) - \dot{\psi}c\theta c\psi s\phi - \dot{\psi}c\phi s\psi - \dot{\phi}c\theta c\phi s\psi + \dot{\theta}s\theta s\phi s\psi)) - \ddot{\theta}_{11i}c\theta_{11i}c\theta_{13i} \tan \theta_{12i} + \dot{\theta}_{11i}^2 c\theta_{13i}
 \end{aligned}$$

$$\begin{aligned}
& \delta_{17i})(c\delta_{6i}c\theta_{8i}s(\delta_{1i}+\delta_{3i})+c(\delta_{1i}+\delta_{3i})(c\theta_{4i}c\theta_{8i}s\delta_{6i}-s\theta_{4i}s\theta_{8i}))s\psi \tan \theta_{12i}+\dot{\phi}^2c\theta \\
& c\phi s(\delta_{15i}+\delta_{17i})(c\delta_{6i}c\theta_{8i}s(\delta_{1i}+\delta_{3i})+c(\delta_{1i}+\delta_{3i})(c\theta_{4i}c\theta_{8i}s\delta_{6i}-s\theta_{4i}s\theta_{8i}))s\psi \\
& \tan \theta_{12i}+\dot{\psi}^2c\theta c\phi s(\delta_{15i}+\delta_{17i})(c\delta_{6i}c\theta_{8i}s(\delta_{1i}+\delta_{3i})+c(\delta_{1i}+\delta_{3i})(c\theta_{4i}c\theta_{8i}s\delta_{6i}-s\theta_{4i} \\
& s\theta_{8i}))s\psi \tan \theta_{12i}-\dot{\phi}^2c(\delta_{15i}+\delta_{17i})c\phi(c(\delta_{1i}+\delta_{3i})c\delta_{6i}c\theta_{8i}+s(\delta_{1i}+\delta_{3i})(-c\theta_{4i}c\theta_{8i} \\
& s\delta_{6i})+s\theta_{4i}s\theta_{8i}))s\psi \tan \theta_{12i}-\dot{\psi}^2c(\delta_{15i}+\delta_{17i})c\phi(c(\delta_{1i}+\delta_{3i})c\delta_{6i}c\theta_{8i}+s(\delta_{1i}+\delta_{3i}) \\
& (-c\theta_{4i}c\theta_{8i}s\delta_{6i})+s\theta_{4i}s\theta_{8i}))s\psi \tan \theta_{12i}-2\dot{\theta}\dot{\phi}s(\delta_{15i}+\delta_{17i})s\theta(c\delta_{6i}c\theta_{8i}s(\delta_{1i}+\delta_{3i})+ \\
& c(\delta_{1i}+\delta_{3i})(c\theta_{4i}c\theta_{8i}s\delta_{6i}-s\theta_{4i}s\theta_{8i}))s\phi s\psi \tan \theta_{12i}+2\dot{\theta}\dot{\psi}c(\delta_{15i}+\delta_{17i})(-c\delta_{6i}c\theta_{8i} \\
& s(\delta_{1i}+\delta_{3i}))+c(\delta_{1i}+\delta_{3i})(-c\theta_{4i}c\theta_{8i}s\delta_{6i})+s\theta_{4i}s\theta_{8i}))s\phi s\psi \tan \theta_{12i}+\dot{\theta}^2c(\delta_{15i}+ \\
& \delta_{17i})c\theta(-c\delta_{6i}c\theta_{8i}s(\delta_{1i}+\delta_{3i}))+c(\delta_{1i}+\delta_{3i})(-c\theta_{4i}c\theta_{8i}s\delta_{6i})+s\theta_{4i}s\theta_{8i}))s\phi s\psi \\
& \tan \theta_{12i}+\dot{\phi}^2c(\delta_{15i}+\delta_{17i})c\theta(-c\delta_{6i}c\theta_{8i}s(\delta_{1i}+\delta_{3i}))+c(\delta_{1i}+\delta_{3i})(-c\theta_{4i}c\theta_{8i}s\delta_{6i})+ \\
& s\theta_{4i}s\theta_{8i}))s\phi s\psi \tan \theta_{12i}+\dot{\psi}^2c(\delta_{15i}+\delta_{17i})c\theta(-c\delta_{6i}c\theta_{8i}s(\delta_{1i}+\delta_{3i}))+c(\delta_{1i}+\delta_{3i})(- \\
& c\theta_{4i}c\theta_{8i}s\delta_{6i})+s\theta_{4i}s\theta_{8i}))s\phi s\psi \tan \theta_{12i}-\dot{\phi}^2s(\delta_{15i}+\delta_{17i})(c(\delta_{1i}+\delta_{3i})c\delta_{6i}c\theta_{8i}+ \\
& s(\delta_{1i}+\delta_{3i})(-c\theta_{4i}c\theta_{8i}s\delta_{6i})+s\theta_{4i}s\theta_{8i}))s\phi s\psi \tan \theta_{12i}-\dot{\psi}^2s(\delta_{15i}+\delta_{17i})(c(\delta_{1i}+ \\
& \delta_{3i})c\delta_{6i}c\theta_{8i}+s(\delta_{1i}+\delta_{3i})(-c\theta_{4i}c\theta_{8i}s\delta_{6i})+s\theta_{4i}s\theta_{8i}))s\phi s\psi \tan \theta_{12i}+2\dot{\theta}\dot{\psi}c(\delta_{15i}+ \\
& \delta_{17i})s\theta(c(\delta_{1i}+\delta_{3i})c\delta_{6i}c\theta_{8i}+s(\delta_{1i}+\delta_{3i})(-c\theta_{4i}c\theta_{8i}s\delta_{6i})+s\theta_{4i}s\theta_{8i}))s\phi s\psi \\
& \tan \theta_{12i}+2\dot{\psi}s(\delta_{15i}+\delta_{17i})(c(\delta_{1i}+\delta_{3i})c\delta_{6i}c\theta_{8i}+s(\delta_{1i}+\delta_{3i})(-c\theta_{4i}c\theta_{8i}s\delta_{6i})+s\theta_{4i} \\
& s\theta_{8i}))(-\dot{\theta}c\phi s\theta)-\dot{\phi}c\theta s\phi)s\psi \tan \theta_{12i}+2\dot{\phi}c(\delta_{15i}+\delta_{17i})c\phi(c(\delta_{1i}+\delta_{3i})c\delta_{6i}c\theta_{8i}+ \\
& s(\delta_{1i}+\delta_{3i})(-c\theta_{4i}c\theta_{8i}s\delta_{6i})+s\theta_{4i}s\theta_{8i}))(-\dot{\theta}c\psi s\theta)-\dot{\psi}c\theta s\psi) \tan \theta_{12i}+c(\delta_{15i}+ \\
& \delta_{17i})(c(\delta_{1i}+\delta_{3i})c\delta_{6i}(-\dot{\theta}_{8i}^2c\theta_{8i})-\ddot{\theta}_{8i}s\theta_{8i})+s(\delta_{1i}+\delta_{3i})(2\dot{\theta}_{4i}\dot{\theta}_{8i}c\theta_{4i}c\theta_{8i}+c\theta_{8i}s\delta_{6i} \\
& (\dot{\theta}_{4i}^2c\theta_{4i}+\ddot{\theta}_{4i}s\theta_{4i})-2\dot{\theta}_{4i}\dot{\theta}_{8i}s\delta_{6i}s\theta_{4i}s\theta_{8i}+(\ddot{\theta}_{4i}c\theta_{4i}-\dot{\theta}_{4i}^2s\theta_{4i})s\theta_{8i}-c\theta_{4i}s\delta_{6i}(-\dot{\theta}_{8i}^2c\theta_{8i})- \\
& \ddot{\theta}_{8i}s\theta_{8i})+s\theta_{4i}(\ddot{\theta}_{8i}c\theta_{8i}-\dot{\theta}_{8i}^2s\theta_{8i})))c\theta c\psi s\phi+c\phi s\psi) \tan \theta_{12i}+2\dot{\theta}c(\delta_{15i}+\delta_{17i})s\theta(- \\
& c\delta_{6i}c\theta_{8i}s(\delta_{1i}+\delta_{3i}))+c(\delta_{1i}+\delta_{3i})(-c\theta_{4i}c\theta_{8i}s\delta_{6i})+s\theta_{4i}s\theta_{8i}))(\dot{\psi}c\psi s\phi+\dot{\phi}c\phi s\psi) \\
& \tan \theta_{12i}-s(\delta_{15i}+\delta_{17i})(c\delta_{6i}s(\delta_{1i}+\delta_{3i})(-\dot{\theta}_{8i}^2c\theta_{8i})-\ddot{\theta}_{8i}s\theta_{8i})+c(\delta_{1i}+\delta_{3i})(-2\dot{\theta}_{4i}\dot{\theta}_{8i} \\
& c\theta_{4i}c\theta_{8i}+(-\ddot{\theta}_{4i}c\theta_{4i})+\dot{\theta}_{4i}^2s\theta_{4i})s\theta_{8i}-s\theta_{4i}(\ddot{\theta}_{8i}c\theta_{8i}-\dot{\theta}_{8i}^2s\theta_{8i})+s\delta_{6i}(c\theta_{8i}(-\dot{\theta}_{4i}^2c\theta_{4i})- \\
& \ddot{\theta}_{4i}s\theta_{4i})+2\dot{\theta}_{4i}\dot{\theta}_{8i}s\theta_{4i}s\theta_{8i}+c\theta_{4i}(-\dot{\theta}_{8i}^2c\theta_{8i})-\ddot{\theta}_{8i}s\theta_{8i})))c\psi s\phi+c\theta c\phi s\psi) \tan \theta_{12i}- \\
& 2s(\delta_{15i}+\delta_{17i})(-\dot{\theta}_{8i}c(\delta_{1i}+\delta_{3i})c\delta_{6i}s\theta_{8i})+s(\delta_{1i}+\delta_{3i})(\dot{\theta}_{8i}c\theta_{8i}s\theta_{4i}+\dot{\theta}_{4i}c\theta_{8i}s\delta_{6i} \\
& s\theta_{4i}+\dot{\theta}_{4i}c\theta_{4i}s\theta_{8i}+\dot{\theta}_{8i}c\theta_{4i}s\delta_{6i}s\theta_{8i}))(-\dot{\theta}c\phi c\psi s\theta)-\dot{\psi}c\psi s\phi-\dot{\phi}c\theta c\psi s\phi-\dot{\phi}c\phi s\psi- \\
& \dot{\psi}c\theta c\phi s\psi) \tan \theta_{12i}-s(\delta_{15i}+\delta_{17i})(c(\delta_{1i}+\delta_{3i})c\delta_{6i}(-\dot{\theta}_{8i}^2c\theta_{8i})-\ddot{\theta}_{8i}s\theta_{8i})+s(\delta_{1i}+ \\
& \delta_{3i})(2\dot{\theta}_{4i}\dot{\theta}_{8i}c\theta_{4i}c\theta_{8i}+c\theta_{8i}s\delta_{6i}(\dot{\theta}_{4i}^2c\theta_{4i}+\ddot{\theta}_{4i}s\theta_{4i})-2\dot{\theta}_{4i}\dot{\theta}_{8i}s\delta_{6i}s\theta_{4i}s\theta_{8i}+(\ddot{\theta}_{4i}c\theta_{4i}-\dot{\theta}_{4i}^2 \\
& s\theta_{4i})s\theta_{8i}-c\theta_{4i}s\delta_{6i}(-\dot{\theta}_{8i}^2c\theta_{8i})-\ddot{\theta}_{8i}s\theta_{8i})+s\theta_{4i}(\ddot{\theta}_{8i}c\theta_{8i}-\dot{\theta}_{8i}^2s\theta_{8i})))c\theta c\phi c\psi-s\phi s\psi) \\
& \tan \theta_{12i}+c(\delta_{15i}+\delta_{17i})(-c\delta_{6i}s(\delta_{1i}+\delta_{3i})(-\dot{\theta}_{8i}^2c\theta_{8i})-\ddot{\theta}_{8i}s\theta_{8i}))+c(\delta_{1i}+\delta_{3i})(2\dot{\theta}_{4i} \\
& \dot{\theta}_{8i}c\theta_{4i}c\theta_{8i}+c\theta_{8i}s\delta_{6i}(\dot{\theta}_{4i}^2c\theta_{4i}+\ddot{\theta}_{4i}s\theta_{4i})-2\dot{\theta}_{4i}\dot{\theta}_{8i}s\delta_{6i}s\theta_{4i}s\theta_{8i}+(\ddot{\theta}_{4i}c\theta_{4i}-\dot{\theta}_{4i}^2s\theta_{4i})s\theta_{8i}- \\
& c\theta_{4i}s\delta_{6i}(-\dot{\theta}_{8i}^2c\theta_{8i})-\ddot{\theta}_{8i}s\theta_{8i})))c\psi s\phi+c\theta c\phi s\psi) \tan \theta_{12i}-
\end{aligned}$$

$$\begin{aligned}
& c\theta_{4i}s\delta_{6i}(-\dot{\theta}_{8i}^2c\theta_{8i})-\ddot{\theta}_{8i}s\theta_{8i})+s\theta_{4i}(\ddot{\theta}_{8i}c\theta_{8i}-\dot{\theta}_{8i}^2s\theta_{8i})))(c\phi c\psi-c\theta s\phi s\psi)\tan\theta_{12i}- \\
& 2s(\delta_{15i}+\delta_{17i})(-\dot{\theta}_{8i}c\delta_{6i}s(\delta_{1i}+\delta_{3i})s\theta_{8i})+c(\delta_{1i}+\delta_{3i})(-\dot{\theta}_{8i}c\theta_{8i}s\theta_{4i})-\dot{\theta}_{4i}c\theta_{8i}s\delta_{6i} \\
& s\theta_{4i}-\dot{\theta}_{4i}c\theta_{4i}s\theta_{8i}-\dot{\theta}_{8i}c\theta_{4i}s\delta_{6i}s\theta_{8i}))(\dot{\phi}c\phi c\psi+\dot{\psi}c\theta c\phi c\psi-\dot{\theta}c\phi s\theta s\psi-\dot{\psi}s\phi s\psi-\dot{\phi}c\theta \\
& s\phi s\psi)\tan\theta_{12i}+2c(\delta_{15i}+\delta_{17i})(-\dot{\theta}_{8i}c(\delta_{1i}+\delta_{3i})c\delta_{6i}s\theta_{8i})+s(\delta_{1i}+\delta_{3i})(\dot{\theta}_{8i}c\theta_{8i} \\
& s\theta_{4i}+\dot{\theta}_{4i}c\theta_{8i}s\delta_{6i}s\theta_{4i}+\dot{\theta}_{4i}c\theta_{4i}s\theta_{8i}+\dot{\theta}_{8i}c\theta_{4i}s\delta_{6i}s\theta_{8i}))(\dot{\psi}c\phi c\psi+\dot{\phi}c\theta c\phi c\psi-\dot{\theta}c\psi s\theta \\
& s\phi-\dot{\phi}s\phi s\psi-\dot{\psi}c\theta s\phi s\psi)\tan\theta_{12i}+2c(\delta_{15i}+\delta_{17i})(\dot{\theta}_{8i}c\delta_{6i}s(\delta_{1i}+\delta_{3i})s\theta_{8i}+c(\delta_{1i}+ \\
& \delta_{3i})(\dot{\theta}_{8i}c\theta_{8i}s\theta_{4i}+\dot{\theta}_{4i}c\theta_{8i}s\delta_{6i}s\theta_{4i}+\dot{\theta}_{4i}c\theta_{4i}s\theta_{8i}+\dot{\theta}_{8i}c\theta_{4i}s\delta_{6i}s\theta_{8i}))(-\dot{\phi}c\psi s\phi)-\dot{\psi}c\theta \\
& c\psi s\phi-\dot{\psi}c\phi s\psi-\dot{\phi}c\theta c\phi s\psi+\dot{\theta}s\theta s\phi s\psi)\tan\theta_{12i}+2\dot{\theta}_{12i}^2\sec^2\theta_{12i}(-(s(\delta_{15i}+\delta_{17i}))(c\phi \\
& s\theta(c\theta_{8i}s\delta_{6i}s\theta_{4i}+c\theta_{4i}s\theta_{8i}))+c\delta_{6i}c\theta_{8i}s(\delta_{1i}+\delta_{3i})+c(\delta_{1i}+\delta_{3i})(c\theta_{4i}c\theta_{8i}s\delta_{6i}-s\theta_{4i} \\
& s\theta_{8i}))(c\psi s\phi+c\theta c\phi s\psi)+(c(\delta_{1i}+\delta_{3i})c\delta_{6i}c\theta_{8i}+s(\delta_{1i}+\delta_{3i})(-c\theta_{4i}c\theta_{8i}s\delta_{6i})+ \\
& s\theta_{4i}s\theta_{8i}))(c\theta c\phi c\psi-s\phi s\psi)))+c(\delta_{15i}+\delta_{17i})(s\theta(c\theta_{8i}s\delta_{6i}s\theta_{4i}+c\theta_{4i}s\theta_{8i})s\phi+(\\
& c(\delta_{1i}+\delta_{3i})c\delta_{6i}c\theta_{8i}+s(\delta_{1i}+\delta_{3i})(-c\theta_{4i}c\theta_{8i}s\delta_{6i})+s\theta_{4i}s\theta_{8i}))(c\theta c\psi s\phi+c\phi s\psi)+ \\
& (-c\delta_{6i}c\theta_{8i}s(\delta_{1i}+\delta_{3i}))+c(\delta_{1i}+\delta_{3i})(-c\theta_{4i}c\theta_{8i}s\delta_{6i})+s\theta_{4i}s\theta_{8i}))(c\phi c\psi-c\theta s\phi \\
& s\psi))\tan\theta_{12i}))
\end{aligned}$$

Apéndice E

Desarrollo y comprobación de la ec. (4.73):

$$\dot{\mathbf{R}}_{4i}^{9i} \mathbf{j}_{4i}^{4i} = \boldsymbol{\omega}_{94i}^{9i} \times \mathbf{R}_{4i}^{9i} \mathbf{j}_{4i}^{4i}$$

Desarrollando el término izquierdo de la ec. anterior, donde:

$$\begin{aligned} \mathbf{R}_{4i}^{9i} &= \mathbf{R}_{z5}(-\theta_{9i}) \mathbf{R}_{z4}(-\theta_{8i}) \mathbf{R}_{z6}(-\delta_{6i}) \\ \mathbf{j}_{4i}^{4i} &= [0, 1, 0]^T \end{aligned}$$

Derivando la matriz de rotación respecto al tiempo:

$$\begin{aligned} \dot{\mathbf{R}}_{4i}^{9i} &= \frac{\partial \mathbf{R}_{z5}(-\theta_{9i})}{\partial \theta_{9i}} \mathbf{R}_{z4}(-\theta_{8i}) \mathbf{R}_{z6}(-\delta_{6i}) \dot{\theta}_{9i} + \\ &\quad \mathbf{R}_{z5}(-\theta_{9i}) \frac{\partial \mathbf{R}_{z4}(-\theta_{8i})}{\partial \theta_{8i}} \mathbf{R}_{z6}(-\delta_{6i}) \dot{\theta}_{8i} \end{aligned}$$

Haciendo uso de las matrices de rotación definidas en el capítulo 3 y desarrollando, se tienen cada uno de los elementos de $\dot{\mathbf{R}}_{4i}^{9i}$:

$$\begin{aligned} \dot{\mathbf{R}}_{4i[1,1]}^{9i} &= -\dot{\theta}_{8i} c\theta_{8i} s\delta_{6i} s\theta_{9i} - \dot{\theta}_{9i} (c\theta_{9i} s\delta_{6i} s\theta_{8i} + c\delta_{6i} s\theta_{9i}) \\ \dot{\mathbf{R}}_{4i[1,2]}^{9i} &= \dot{\theta}_{8i} c\delta_{6i} c\theta_{8i} s\theta_{9i} + \dot{\theta}_{9i} (c\delta_{6i} c\theta_{9i} s\theta_{8i} - s\delta_{6i} s\theta_{9i}) \\ \dot{\mathbf{R}}_{4i[1,3]}^{9i} &= -(\dot{\theta}_{9i} c\theta_{8i} c\theta_{9i}) + \dot{\theta}_{8i} s\theta_{8i} s\theta_{9i} \\ \dot{\mathbf{R}}_{4i[2,1]}^{9i} &= \dot{\theta}_{8i} s\delta_{6i} s\theta_{8i} \\ \dot{\mathbf{R}}_{4i[2,2]}^{9i} &= -(\dot{\theta}_{8i} c\delta_{6i} s\theta_{8i}) \\ \dot{\mathbf{R}}_{4i[2,3]}^{9i} &= \dot{\theta}_{8i} c\theta_{8i} \\ \dot{\mathbf{R}}_{4i[3,1]}^{9i} &= \dot{\theta}_{8i} c\theta_{8i} c\theta_{9i} s\delta_{6i} + \dot{\theta}_{9i} (c\delta_{6i} c\theta_{9i} - s\delta_{6i} s\theta_{8i} s\theta_{9i}) \\ \dot{\mathbf{R}}_{4i[3,2]}^{9i} &= -(\dot{\theta}_{8i} c\delta_{6i} c\theta_{8i} c\theta_{9i}) + \dot{\theta}_{9i} (c\theta_{9i} s\delta_{6i} + c\delta_{6i} s\theta_{8i} s\theta_{9i}) \\ \dot{\mathbf{R}}_{4i[3,3]}^{9i} &= -(\dot{\theta}_{8i} c\theta_{9i} s\theta_{8i}) - \dot{\theta}_{9i} c\theta_{8i} s\theta_{9i} \end{aligned}$$

Ahora al multiplicar $\dot{\mathbf{R}}_{4i}^{9i} \mathbf{j}_{4i}^{4i}$:

$$\dot{\mathbf{R}}_{4i}^{9i} \mathbf{j}_{4i}^{4i} = \begin{pmatrix} \dot{\theta}_{8i} c\delta_{6i} c\theta_{8i} s\theta_{9i} + \dot{\theta}_{9i} (c\delta_{6i} c\theta_{9i} s\theta_{8i} - s\delta_{6i} s\theta_{9i}) \\ -\dot{\theta}_{8i} (c\delta_{6i} s\theta_{8i}) \\ -\dot{\theta}_{8i} (c\delta_{6i} c\theta_{8i} c\theta_{9i}) + \dot{\theta}_{9i} (c\theta_{9i} s\delta_{6i} + c\delta_{6i} s\theta_{8i} s\theta_{9i}) \end{pmatrix} \quad (\text{e.1})$$

Desarrollando el segundo término, donde:

$$\boldsymbol{\omega}_{94i}^{9i} = -\mathbf{R}_{8i}^{9i} \dot{\boldsymbol{\theta}}_{8i} \mathbf{i}_{8i}^{8i} - \dot{\boldsymbol{\theta}}_{9i} \mathbf{j}_{9i}^{9i}$$

$$\mathbf{R}_{8i}^{9i} = \mathbf{R}_{z5}(-\theta_{9i})$$

$$\mathbf{j}_{9i}^{9i} = [0, 1, 0]^T$$

$$\mathbf{i}_{8i}^{8i} = [1, 0, 0]^T$$

Al desarrollar $\boldsymbol{\omega}_{94i}^{9i}$, se tiene:

$$\boldsymbol{\omega}_{94i}^{9i} = \begin{pmatrix} -(c\theta_{9i} \dot{\boldsymbol{\theta}}_{8i}) \\ -\dot{\boldsymbol{\theta}}_{9i} \\ -(\dot{\boldsymbol{\theta}}_{8i} s\theta_{9i}) \end{pmatrix}$$

$\mathbf{R}_{4i}^{9i} \mathbf{j}_{4i}^{4i}$:

$$\mathbf{R}_{4i}^{9i} \mathbf{j}_{4i}^{4i} = \begin{pmatrix} c\theta_{9i} s\delta_{6i} + c\delta_{6i} s\theta_{8i} s\theta_{9i} \\ c\delta_{6i} c\theta_{8i} \\ -(c\delta_{6i} c\theta_{9i} s\theta_{8i}) + s\delta_{6i} s\theta_{9i} \end{pmatrix}$$

Ahora haciendo el producto cruz entre estos últimos $\boldsymbol{\omega}_{94i}^{9i} \times \mathbf{R}_{4i}^{9i} \mathbf{j}_{4i}^{4i}$:

$$\boldsymbol{\omega}_{94i}^{9i} \times \mathbf{R}_{4i}^{9i} \mathbf{j}_{4i}^{4i} = \begin{pmatrix} \dot{\boldsymbol{\theta}}_{8i} c\delta_{6i} c\theta_{8i} s\theta_{9i} + \dot{\boldsymbol{\theta}}_{9i} (c\delta_{6i} c\theta_{9i} s\theta_{8i} - s\delta_{6i} s\theta_{9i}) \\ -\dot{\boldsymbol{\theta}}_{8i} (c\delta_{6i} s\theta_{8i}) \\ -\dot{\boldsymbol{\theta}}_{8i} (c\delta_{6i} c\theta_{8i} c\theta_{9i}) + \dot{\boldsymbol{\theta}}_{9i} (c\theta_{9i} s\delta_{6i} + c\delta_{6i} s\theta_{8i} s\theta_{9i}) \end{pmatrix} \quad (\text{e.2})$$

Finalmente podemos ver que las ecuaciones (e.1) y (e.2) son iguales, por lo tanto, se comprueba que $\dot{\mathbf{R}}_{4i}^{9i} \mathbf{j}_{4i}^{4i} = \boldsymbol{\omega}_{94i}^{9i} \times \mathbf{R}_{4i}^{9i} \mathbf{j}_{4i}^{4i}$, se cumple. De la misma forma se pueden comprobar las ecuaciones (4.75), (4.79) y (4.81).

Desarrollo y comprobación de la ec. (4.88):

En esta sección se realizará el desarrollo matricial del término $\frac{\partial \mathbf{k}_{1i}}{\partial q_j}$, para así demostrar que lo presentado en la sección 4.3.2. es correcto.

Desarrollo matricial:

De la ec. (3.4):

$$\begin{aligned} \mathbf{r}_{G1i}^0 &= \mathbf{r}_{1i}^0 + \mathbf{r}_{G1i'}^0 \\ \mathbf{r}_{G1i}^0 &= \mathbf{r}_{1i}^0 + \mathbf{R}_{4i}^0 \mathbf{r}_{G1i'}^{4i} \end{aligned}$$

Donde:

$$\begin{aligned} \mathbf{r}_{G1i'}^{4i} &= [x_{G1i'}, y_{G1i'}, z_{G1i'}] \\ \mathbf{R}_{4i}^0 &= \mathbf{R}_{z6}(\delta_{1i} + \delta_{3i}) \mathbf{R}_{z5}(\theta_{4i}) \\ \mathbf{R}_0^{4i} &= \mathbf{R}_{z5}(-\theta_{4i}) \mathbf{R}_{z6}(-(\delta_{1i} + \delta_{3i})) \end{aligned}$$

Derivando la ec. (3.4) respecto al tiempo se tiene:

$$\begin{aligned} \mathbf{v}_{G1i}^0 &= \dot{\mathbf{R}}_{4i}^0 \left(\mathbf{R}_{4i}^0 \right)^T \mathbf{r}_{G1i'}^0 \\ &= \mathbf{W}_{4i}^0 \mathbf{r}_{G1i'}^0 \end{aligned}$$

Al desarrollar se obtiene $\mathbf{W}_{4i}^0 = \dot{\theta}_{4i} \mathbf{S}_{4i}^0$ y escribiendo $\mathbf{r}_{G1i'}^0$ en función de $\mathbf{r}_{G1i'}^{4i}$ la ec. anterior, se tiene:

$$\mathbf{v}_{G1i}^0 = \mathbf{S}_{4i}^0 \left(\mathbf{R}_{4i}^0 \mathbf{r}_{G1i'}^{4i} \right) \dot{\theta}_{4i} \quad (\text{e.3})$$

Donde:

$$\mathbf{S}_{4i}^0 = \begin{bmatrix} 0 & 0 & c(\delta_{1i} + \delta_{3i}) \\ 0 & 0 & s(\delta_{1i} + \delta_{3i}) \\ -c(\delta_{1i} + \delta_{3i}) & -s(\delta_{1i} + \delta_{3i}) & 0 \end{bmatrix}$$

Ahora de la ec. (4.5):

$$\mathbf{v}_{G1i}^{4i} = \mathbf{k}_{1i} \dot{\theta}_{4i}$$

Por la semejanza entre las ec. (4.5) y (e.3) nos damos cuenta que \mathbf{k}_{1i} proyectado en la base inercial es:

$$\mathbf{k}_{1i}^0 = \mathbf{S}_{4i}^0 \mathbf{R}_{4i}^0 \mathbf{r}_{G1i'}^{4i}$$

Derivando \mathbf{k}_{1i}^0 respecto a q_j :

$$\begin{aligned} \frac{\partial \mathbf{k}_{1i}^0}{\partial q_j} &= \frac{\partial}{\partial \theta_{4i}} \left(\mathbf{S}_{4i}^0 \mathbf{R}_{4i}^0 \mathbf{r}_{G1i'}^{4i} \right) \frac{\partial \theta_{4i}}{\partial q_j} \\ &= \left(\mathbf{S}_{4i}^0 \frac{\partial \mathbf{R}_{4i}^0}{\partial \theta_{4i}} \mathbf{r}_{G1i'}^{4i} \right) \frac{\partial \theta_{4i}}{\partial q_j} \end{aligned}$$

Ahora proyectando \mathbf{k}_{1i}^0 en la base local 4i:

$$\begin{aligned} \frac{\partial \mathbf{k}_{1i}}{\partial q_j} &= \mathbf{R}_0^{4i} \left(\mathbf{S}_{4i}^0 \frac{\partial \mathbf{R}_{4i}^0}{\partial \theta_{4i}} \mathbf{r}_{G1i'}^{4i} \right) \frac{\partial \theta_{4i}}{\partial q_j} \\ &= \mathbf{J}_{1i,1} \frac{\partial \theta_{4i}}{\partial q_j} \end{aligned} \quad (\text{e.4})$$

Finalmente, desarrollando la ec. (e.4):

$$\frac{\partial \mathbf{k}_{1i}}{\partial q_j} = \begin{bmatrix} -x_{G1i'} \\ 0 \\ -z_{G1i'} \end{bmatrix} \frac{\partial \theta_{4i}}{\partial q_j}$$

Por otro lado, del desarrollo vectorial de la sección 4.3.2., sabemos de la ec. (4.88):

$$\frac{\partial \mathbf{k}_{1i}}{\partial q_j} = \mathbf{j}_{4i}^{4i} \times \left(\mathbf{j}_{4i}^{4i} \times \mathbf{r}_{G1i'}^{4i} \right) \frac{\partial \theta_{4i}}{\partial q_j}$$

Desarrollando la ec. anterior se tiene que:

$$\frac{\partial \mathbf{k}_{1i}}{\partial q_j} = \begin{bmatrix} -x_{G1i'} \\ 0 \\ -z_{G1i'} \end{bmatrix} \frac{\partial \theta_{4i}}{\partial q_j}$$

De esta forma nos damos cuenta que el desarrollo matricial y vectorial arrojan el mismo resultado, por lo tanto, se comprueba que el desarrollo de la sección 4.3.2. es correcto. En el desarrollo de dicha sección se usará el método vectorial para derivar vectores respecto a q_j .

Apéndice F

Desarrollo de la ecuación de lazo

Con el fin de obtener el término $\frac{\partial \theta_i}{\partial q_j}$, que se presenta en la ecuación (4.87), se procederá a generar una ecuación de lazo, la cual nos permitirá relacionar el vector de derivadas parciales respecto a q_j de los ángulos θ_{4i} , θ_{8i} y θ_{9i} con la derivada parcial respecto a q_j del vector de coordenadas generalizadas, esto es:

$$J_i \frac{\partial \theta_i}{\partial q_j} = J_j \frac{\partial q}{\partial q_j}$$

Ecuación de lazo

A continuación se mostrará el desarrollo para la obtención de la ecuación de lazo. A partir de la ec. (2.2):

$$r_{1i}^0 + r_{4i}^0 + r_{6i}^0 + r_{9i}^0 = r_p^0 + r_{15i}^0 + r_{13i}^0$$

Donde:

$$\begin{aligned} r_{1i}^0 &= R_{1i}^0 r_{1i}^{1i} & R_{1i}^0 &= R_{z_6}(\delta_{1i}) \\ r_{4i}^0 &= R_{4i}^0 r_{4i}^{4i} & R_{4i}^0 &= R_{z_6}(\delta_{1i} + \delta_{3i}) R_{z_5}(\theta_{4i}) \\ r_{6i}^0 &= R_{6i}^0 r_{6i}^{6i} & R_{6i}^0 &= R_{z_6}(\delta_{1i} + \delta_{3i}) R_{z_5}(\theta_{4i}) R_{z_6}(\delta_{6i}) \\ r_{9i}^0 &= R_{9i}^0 r_{9i}^{9i} & R_{9i}^0 &= R_{z_6}(\delta_{1i} + \delta_{3i}) R_{z_5}(\theta_{4i}) R_{z_6}(\delta_{6i}) R_{z_4}(\theta_{8i}) R_{z_5}(\theta_{9i}) \\ r_{13i}^0 &= R_{13i}^0 r_{13i}^{13i} & R_{13i}^0 &= R_{z_6}(\psi) R_{z_4}(\theta) R_{z_6}(\phi) R_{z_6}(-\delta_{17i} - \delta_{15i}) \\ r_{15i}^0 &= R_{15i}^0 r_{15i}^{15i} & R_{15i}^0 &= R_{z_6}(\psi) R_{z_4}(\theta) R_{z_6}(\phi) R_{z_6}(-\delta_{17i}) \\ r_p^0 &= [x_p, y_p, z_p]^T \end{aligned}$$

$$\begin{aligned} r_{1i}^{1i} &= [x_{2i}, 0, 0]^T \\ r_{4i}^{4i} &= [x_{5i}, 0, 0]^T \\ r_{6i}^{6i} &= [x_{7i}, 0, 0]^T \\ r_{9i}^{9i} &= [x_{10i}, 0, 0]^T \\ r_{13i}^{13i} &= [-x_{14i}, 0, 0]^T \\ r_{15i}^{15i} &= [-x_{16i}, 0, 0]^T \end{aligned}$$

Derivando la ec. (2.2) respecto a q_j :

$$\begin{aligned} \frac{\partial}{\partial q_j} (\mathbf{r}_{1i}^0 + \mathbf{r}_{4i}^0 + \mathbf{r}_{6i}^0 + \mathbf{r}_{9i}^0) &= \frac{\partial}{\partial q_j} (\mathbf{r}_p^0 + \mathbf{r}_{15i}^0 + \mathbf{r}_{13i}^0) \\ \frac{\partial \mathbf{r}_{1i}^0}{\partial q_j} + \frac{\partial \mathbf{r}_{4i}^0}{\partial q_j} + \frac{\partial \mathbf{r}_{6i}^0}{\partial q_j} + \frac{\partial \mathbf{r}_{9i}^0}{\partial q_j} &= \frac{\partial \mathbf{r}_p^0}{\partial q_j} + \frac{\partial \mathbf{r}_{15i}^0}{\partial q_j} + \frac{\partial \mathbf{r}_{13i}^0}{\partial q_j} \end{aligned} \quad (\text{f.1})$$

Obteniendo cada uno de los componentes de la ec. anterior:

$$\begin{aligned} \frac{\partial \mathbf{r}_{1i}^0}{\partial q_j} &= \mathbf{0} \\ \frac{\partial \mathbf{r}_{4i}^0}{\partial q_j} &= \left(\mathbf{R}_{z6} (\delta_{1i} + \delta_{3i}) \frac{\partial \mathbf{R}_{z5} (\theta_{4i})}{\partial \theta_{4i}} \mathbf{r}_{4i}^{4i} \right) \frac{\partial \theta_{4i}}{\partial q_j} \\ \frac{\partial \mathbf{r}_{6i}^0}{\partial q_j} &= \left(\mathbf{R}_{z6} (\delta_{1i} + \delta_{3i}) \frac{\partial \mathbf{R}_{z5} (\theta_{4i})}{\partial \theta_{4i}} \mathbf{R}_{z6} (\delta_{6i}) \mathbf{r}_{6i}^{6i} \right) \frac{\partial \theta_{4i}}{\partial q_j} \\ \frac{\partial \mathbf{r}_{9i}^0}{\partial q_j} &= \left(\mathbf{R}_{z6} (\delta_{1i} + \delta_{3i}) \frac{\partial \mathbf{R}_{z5} (\theta_{4i})}{\partial \theta_{4i}} \mathbf{R}_{z6} (\delta_{6i}) \mathbf{R}_{z4} (\theta_{8i}) \mathbf{R}_{z5} (\theta_{9i}) \mathbf{r}_{9i}^{9i} \right) \frac{\partial \theta_{4i}}{\partial q_j} + \\ &\quad \left(\mathbf{R}_{z6} (\delta_{1i} + \delta_{3i}) \mathbf{R}_{z5} (\theta_{4i}) \mathbf{R}_{z6} (\delta_{6i}) \frac{\partial \mathbf{R}_{z4} (\theta_{8i})}{\partial \theta_{8i}} \mathbf{R}_{z5} (\theta_{9i}) \mathbf{r}_{9i}^{9i} \right) \frac{\partial \theta_{8i}}{\partial q_j} + \\ &\quad \left(\mathbf{R}_{z6} (\delta_{1i} + \delta_{3i}) \mathbf{R}_{z5} (\theta_{4i}) \mathbf{R}_{z6} (\delta_{6i}) \mathbf{R}_{z4} (\theta_{8i}) \frac{\partial \mathbf{R}_{z5} (\theta_{9i})}{\partial \theta_{9i}} \mathbf{r}_{9i}^{9i} \right) \frac{\partial \theta_{9i}}{\partial q_j} \\ \frac{\partial \mathbf{r}_{13i}^0}{\partial q_j} &= \left(\frac{\partial \mathbf{R}_{z6} (\psi)}{\partial \psi} \mathbf{R}_{z4} (\theta) \mathbf{R}_{z6} (\phi) \mathbf{R}_{z6} (-\delta_{17i} - \delta_{15i}) \mathbf{r}_{13i}^{13i} \right) \frac{\partial \psi}{\partial q_j} + \\ &\quad \left(\mathbf{R}_{z6} (\psi) \frac{\partial \mathbf{R}_{z4} (\theta)}{\partial \theta} \mathbf{R}_{z6} (\phi) \mathbf{R}_{z6} (-\delta_{17i} - \delta_{15i}) \mathbf{r}_{13i}^{13i} \right) \frac{\partial \theta}{\partial q_j} + \\ &\quad \left(\mathbf{R}_{z6} (\psi) \mathbf{R}_{z4} (\theta) \frac{\partial \mathbf{R}_{z6} (\phi)}{\partial \phi} \mathbf{R}_{z6} (-\delta_{17i} - \delta_{15i}) \mathbf{r}_{13i}^{13i} \right) \frac{\partial \phi}{\partial q_j} \\ \frac{\partial \mathbf{r}_{15i}^0}{\partial q_j} &= \left(\frac{\partial \mathbf{R}_{z6} (\psi)}{\partial \psi} \mathbf{R}_{z4} (\theta) \mathbf{R}_{z6} (\phi) \mathbf{R}_{z6} (-\delta_{17i}) \mathbf{r}_{15i}^{15i} \right) \frac{\partial \psi}{\partial q_j} + \\ &\quad \left(\mathbf{R}_{z6} (\psi) \frac{\partial \mathbf{R}_{z4} (\theta)}{\partial \theta} \mathbf{R}_{z6} (\phi) \mathbf{R}_{z6} (-\delta_{17i}) \mathbf{r}_{15i}^{15i} \right) \frac{\partial \theta}{\partial q_j} + \\ &\quad \left(\mathbf{R}_{z6} (\psi) \mathbf{R}_{z4} (\theta) \frac{\partial \mathbf{R}_{z6} (\phi)}{\partial \phi} \mathbf{R}_{z6} (-\delta_{17i}) \mathbf{r}_{15i}^{15i} \right) \frac{\partial \phi}{\partial q_j} \end{aligned}$$

Sustituyendo los términos anteriores en la ec. (f.1):

$$\begin{aligned}
 & \left(\mathbf{R}_{z6} (\delta_{1i} + \delta_{3i}) \frac{\partial \mathbf{R}_{z5} (\theta_{4i})}{\partial \theta_{4i}} \mathbf{r}_{4i}^{4i} \right) \frac{\partial \theta_{4i}}{\partial q_j} + \left(\mathbf{R}_{z6} (\delta_{1i} + \delta_{3i}) \frac{\partial \mathbf{R}_{z5} (\theta_{4i})}{\partial \theta_{4i}} \mathbf{R}_{z6} (\delta_{6i}) \mathbf{r}_{6i}^{6i} \right) \frac{\partial \theta_{4i}}{\partial q_j} + \\
 & \left(\mathbf{R}_{z6} (\delta_{1i} + \delta_{3i}) \frac{\partial \mathbf{R}_{z5} (\theta_{4i})}{\partial \theta_{4i}} \mathbf{R}_{z6} (\delta_{6i}) \mathbf{R}_{z4} (\theta_{8i}) \mathbf{R}_{z5} (\theta_{9i}) \mathbf{r}_{9i}^{9i} \right) \frac{\partial \theta_{4i}}{\partial q_j} + \\
 & \left(\mathbf{R}_{z6} (\delta_{1i} + \delta_{3i}) \mathbf{R}_{z5} (\theta_{4i}) \mathbf{R}_{z6} (\delta_{6i}) \frac{\partial \mathbf{R}_{z4} (\theta_{8i})}{\partial \theta_{8i}} \mathbf{R}_{z5} (\theta_{9i}) \mathbf{r}_{9i}^{9i} \right) \frac{\partial \theta_{8i}}{\partial q_j} + \\
 & \left(\mathbf{R}_{z6} (\delta_{1i} + \delta_{3i}) \mathbf{R}_{z5} (\theta_{4i}) \mathbf{R}_{z6} (\delta_{6i}) \mathbf{R}_{z4} (\theta_{8i}) \frac{\partial \mathbf{R}_{z5} (\theta_{9i})}{\partial \theta_{9i}} \mathbf{r}_{9i}^{9i} \right) \frac{\partial \theta_{9i}}{\partial q_j} = \\
 & \frac{\partial \mathbf{r}_p^0}{\partial q_j} + \left(\frac{\partial \mathbf{R}_{z6} (\psi)}{\partial \psi} \mathbf{R}_{z4} (\theta) \mathbf{R}_{z6} (\phi) \mathbf{R}_{z6} (-\delta_{17i} - \delta_{15i}) \mathbf{r}_{13i}^{13i} \right) \frac{\partial \psi}{\partial q_j} + \\
 & \left(\mathbf{R}_{z6} (\psi) \frac{\partial \mathbf{R}_{z4} (\theta)}{\partial \theta} \mathbf{R}_{z6} (\phi) \mathbf{R}_{z6} (-\delta_{17i} - \delta_{15i}) \mathbf{r}_{13i}^{13i} \right) \frac{\partial \theta}{\partial q_j} + \\
 & \left(\mathbf{R}_{z6} (\psi) \mathbf{R}_{z4} (\theta) \frac{\partial \mathbf{R}_{z6} (\phi)}{\partial \phi} \mathbf{R}_{z6} (-\delta_{17i} - \delta_{15i}) \mathbf{r}_{13i}^{13i} \right) \frac{\partial \phi}{\partial q_j} + \\
 & \left(\frac{\partial \mathbf{R}_{z6} (\psi)}{\partial \psi} \mathbf{R}_{z4} (\theta) \mathbf{R}_{z6} (\phi) \mathbf{R}_{z6} (-\delta_{17i}) \mathbf{r}_{15i}^{15i} \right) \frac{\partial \psi}{\partial q_j} + \\
 & \left(\mathbf{R}_{z6} (\psi) \frac{\partial \mathbf{R}_{z4} (\theta)}{\partial \theta} \mathbf{R}_{z6} (\phi) \mathbf{R}_{z6} (-\delta_{17i}) \mathbf{r}_{15i}^{15i} \right) \frac{\partial \theta}{\partial q_j} + \\
 & \left(\mathbf{R}_{z6} (\psi) \mathbf{R}_{z4} (\theta) \frac{\partial \mathbf{R}_{z6} (\phi)}{\partial \phi} \mathbf{R}_{z6} (-\delta_{17i}) \mathbf{r}_{15i}^{15i} \right) \frac{\partial \phi}{\partial q_j}
 \end{aligned}$$

Simplificando y agrupando los términos semejantes:

$$\begin{aligned}
 & \left(\mathbf{R}_{z6} (\delta_{1i} + \delta_{3i}) \frac{\partial \mathbf{R}_{z5} (\theta_{4i})}{\partial \theta_{4i}} (\mathbf{r}_{4i}^{4i} + \mathbf{R}_{z6} (\delta_{6i}) (\mathbf{r}_{6i}^{6i} + \mathbf{R}_{z4} (\theta_{8i}) \mathbf{R}_{z5} (\theta_{9i}) \mathbf{r}_{9i}^{9i})) \right) \frac{\partial \theta_{4i}}{\partial q_j} + \\
 & \left(\mathbf{R}_{z6} (\delta_{1i} + \delta_{3i}) \mathbf{R}_{z5} (\theta_{4i}) \mathbf{R}_{z6} (\delta_{6i}) \frac{\partial \mathbf{R}_{z4} (\theta_{8i})}{\partial \theta_{8i}} \mathbf{R}_{z5} (\theta_{9i}) \mathbf{r}_{9i}^{9i} \right) \frac{\partial \theta_{8i}}{\partial q_j} + \\
 & \left(\mathbf{R}_{z6} (\delta_{1i} + \delta_{3i}) \mathbf{R}_{z5} (\theta_{4i}) \mathbf{R}_{z6} (\delta_{6i}) \mathbf{R}_{z4} (\theta_{8i}) \frac{\partial \mathbf{R}_{z5} (\theta_{9i})}{\partial \theta_{9i}} \mathbf{r}_{9i}^{9i} \right) \frac{\partial \theta_{9i}}{\partial q_j} = \\
 & \frac{\partial \mathbf{r}_p^0}{\partial q_j} + \left(\frac{\partial \mathbf{R}_{z6} (\psi)}{\partial \psi} \mathbf{R}_{z4} (\theta) \mathbf{R}_{z6} (\phi) \mathbf{R}_{z6} (-\delta_{17i}) (\mathbf{r}_{15i}^{15i} + \mathbf{R}_{z6} (-\delta_{15i}) \mathbf{r}_{13i}^{13i}) \right) \frac{\partial \psi}{\partial q_j} + \\
 & \left(\mathbf{R}_{z6} (\psi) \frac{\partial \mathbf{R}_{z4} (\theta)}{\partial \theta} \mathbf{R}_{z6} (\phi) \mathbf{R}_{z6} (-\delta_{17i}) (\mathbf{r}_{15i}^{15i} + \mathbf{R}_{z6} (-\delta_{15i}) \mathbf{r}_{13i}^{13i}) \right) \frac{\partial \theta}{\partial q_j} + \\
 & \left(\mathbf{R}_{z6} (\psi) \mathbf{R}_{z4} (\theta) \frac{\partial \mathbf{R}_{z6} (\phi)}{\partial \phi} \mathbf{R}_{z6} (-\delta_{17i}) (\mathbf{r}_{15i}^{15i} + \mathbf{R}_{z6} (-\delta_{15i}) \mathbf{r}_{13i}^{13i}) \right) \frac{\partial \phi}{\partial q_j}
 \end{aligned}$$

Renombrando y acomodando matricialmente:

$$\mathbf{J}_{\theta_{i,1}} \frac{\partial \theta_{4i}}{\partial q_j} + \mathbf{J}_{\theta_{i,2}} \frac{\partial \theta_{8i}}{\partial q_j} + \mathbf{J}_{\theta_{i,3}} \frac{\partial \theta_{9i}}{\partial q_j} = \mathbf{I}_{3 \times 3} \frac{\partial \mathbf{r}_p^0}{\partial q_j} + \mathbf{J}_{q_{i,1}} \frac{\partial \psi}{\partial q_j} + \mathbf{J}_{q_{i,2}} \frac{\partial \theta}{\partial q_j} + \mathbf{J}_{q_{i,3}} \frac{\partial \phi}{\partial q_j}$$

$$\begin{bmatrix} \mathbf{J}_{\theta_{i,1}} & \mathbf{J}_{\theta_{i,2}} & \mathbf{J}_{\theta_{i,3}} \end{bmatrix} \begin{bmatrix} \frac{\partial \theta_{4i}}{\partial q_j} \\ \frac{\partial \theta_{8i}}{\partial q_j} \\ \frac{\partial \theta_{9i}}{\partial q_j} \end{bmatrix} = \begin{bmatrix} \mathbf{I}_{3 \times 3} & \mathbf{J}_{q_{i,1}} & \mathbf{J}_{q_{i,2}} & \mathbf{J}_{q_{i,3}} \end{bmatrix} \begin{bmatrix} \frac{\partial \mathbf{r}_p^0}{\partial q_j} \\ \frac{\partial \psi}{\partial q_j} \\ \frac{\partial \theta}{\partial q_j} \\ \frac{\partial \phi}{\partial q_j} \end{bmatrix}$$

Finalmente se tiene:

$$\mathbf{J}_{\theta_i} \frac{\partial \boldsymbol{\theta}_i}{\partial q_j} = \mathbf{J}_{q_i} \frac{\partial \mathbf{q}}{\partial q_j} \quad (\text{f.2})$$

Donde:

$$\mathbf{J}_{\theta_i} = \begin{bmatrix} \mathbf{J}_{\theta_{i,1}} & \mathbf{J}_{\theta_{i,2}} & \mathbf{J}_{\theta_{i,3}} \end{bmatrix} \quad \mathbf{J}_{q_i} = \begin{bmatrix} \mathbf{I}_{3 \times 3} & \mathbf{J}_{q_{i,1}} & \mathbf{J}_{q_{i,2}} & \mathbf{J}_{q_{i,3}} \end{bmatrix}$$

$$\frac{\partial \boldsymbol{\theta}}{\partial q_j} = \begin{bmatrix} \frac{\partial \theta_{4i}}{\partial q_j} & \frac{\partial \theta_{8i}}{\partial q_j} & \frac{\partial \theta_{9i}}{\partial q_j} \end{bmatrix}^T \quad \frac{\partial \mathbf{q}}{\partial q_j} = \begin{bmatrix} \frac{\partial \mathbf{r}_p^0}{\partial q_j} & \frac{\partial \psi}{\partial q_j} & \frac{\partial \theta}{\partial q_j} & \frac{\partial \phi}{\partial q_j} \end{bmatrix}^T$$

$$\mathbf{J}_{\theta_{i,1}} = \left(\mathbf{R}_{z_6} (\delta_{1i} + \delta_{3i}) \frac{\partial \mathbf{R}_{z_5} (\theta_{4i})}{\partial \theta_{4i}} \left(\mathbf{r}_{4i}^{4i} + \mathbf{R}_{z_6} (\delta_{6i}) \left(\mathbf{r}_{6i}^{6i} + \mathbf{R}_{z_4} (\theta_{8i}) \mathbf{R}_{z_5} (\theta_{9i}) \mathbf{r}_{9i}^{9i} \right) \right) \right)$$

$$\mathbf{J}_{\theta_{i,2}} = \left(\mathbf{R}_{z_6} (\delta_{1i} + \delta_{3i}) \mathbf{R}_{z_5} (\theta_{4i}) \mathbf{R}_{z_6} (\delta_{6i}) \frac{\partial \mathbf{R}_{z_4} (\theta_{8i})}{\partial \theta_{8i}} \mathbf{R}_{z_5} (\theta_{9i}) \mathbf{r}_{9i}^{9i} \right)$$

$$\mathbf{J}_{\theta_{i,3}} = \left(\mathbf{R}_{z_6} (\delta_{1i} + \delta_{3i}) \mathbf{R}_{z_5} (\theta_{4i}) \mathbf{R}_{z_6} (\delta_{6i}) \mathbf{R}_{z_4} (\theta_{8i}) \frac{\partial \mathbf{R}_{z_5} (\theta_{9i})}{\partial \theta_{9i}} \mathbf{r}_{9i}^{9i} \right)$$

$$\mathbf{J}_{q_{i,1}} = \left(\frac{\partial \mathbf{R}_{z_6} (\psi)}{\partial \psi} \mathbf{R}_{z_4} (\theta) \mathbf{R}_{z_6} (\phi) \mathbf{R}_{z_6} (-\delta_{17i}) \left(\mathbf{r}_{15i}^{15i} + \mathbf{R}_{z_6} (-\delta_{15i}) \mathbf{r}_{13i}^{13i} \right) \right)$$

$$\mathbf{J}_{q_{i,2}} = \left(\mathbf{R}_{z_6} (\psi) \frac{\partial \mathbf{R}_{z_4} (\theta)}{\partial \theta} \mathbf{R}_{z_6} (\phi) \mathbf{R}_{z_6} (-\delta_{17i}) \left(\mathbf{r}_{15i}^{15i} + \mathbf{R}_{z_6} (-\delta_{15i}) \mathbf{r}_{13i}^{13i} \right) \right)$$

$$\mathbf{J}_{q_{i,3}} = \left(\mathbf{R}_{z_6} (\psi) \mathbf{R}_{z_4} (\theta) \frac{\partial \mathbf{R}_{z_6} (\phi)}{\partial \phi} \mathbf{R}_{z_6} (-\delta_{17i}) \left(\mathbf{r}_{15i}^{15i} + \mathbf{R}_{z_6} (-\delta_{15i}) \mathbf{r}_{13i}^{13i} \right) \right)$$

Al evaluar el término $\frac{\partial \mathbf{q}}{\partial q_j}$, dependerá que valor tome j, de tal manera que se tienen los siguientes resultados para diferente valor del iterador j.

De esta forma, para:

$$j=1$$

$$\frac{\partial \mathbf{q}}{\partial q_1} = \frac{\partial}{\partial q_1} [x_p, y_p, z_p, \psi, \theta, \phi] = \frac{\partial}{\partial x_p} [x_p, y_p, z_p, \psi, \theta, \phi]$$

$$\frac{\partial \mathbf{q}}{\partial q_1} = [1, 0, 0, 0, 0, 0]$$

$$j=3$$

$$\frac{\partial \mathbf{q}}{\partial q_3} = \frac{\partial}{\partial q_3} [x_p, y_p, z_p, \psi, \theta, \phi] = \frac{\partial}{\partial z_p} [x_p, y_p, z_p, \psi, \theta, \phi]$$

$$\frac{\partial \mathbf{q}}{\partial q_3} = [0, 0, 1, 0, 0, 0]$$

$$j=4$$

$$\frac{\partial \mathbf{q}}{\partial q_4} = \frac{\partial}{\partial q_4} [x_p, y_p, z_p, \psi, \theta, \phi] = \frac{\partial}{\partial \psi} [x_p, y_p, z_p, \psi, \theta, \phi]$$

$$\frac{\partial \mathbf{q}}{\partial q_4} = [0, 0, 0, 1, 0, 0]$$

$$j=5$$

$$\frac{\partial \mathbf{q}}{\partial q_5} = \frac{\partial}{\partial q_5} [x_p, y_p, z_p, \psi, \theta, \phi] = \frac{\partial}{\partial \theta} [x_p, y_p, z_p, \psi, \theta, \phi]$$

$$\frac{\partial \mathbf{q}}{\partial q_5} = [0, 0, 0, 0, 1, 0]$$

$$j=6$$

$$\frac{\partial \mathbf{q}}{\partial q_6} = \frac{\partial}{\partial q_6} [x_p, y_p, z_p, \psi, \theta, \phi] = \frac{\partial}{\partial \phi} [x_p, y_p, z_p, \psi, \theta, \phi]$$

$$\frac{\partial \mathbf{q}}{\partial q_6} = [0, 0, 0, 0, 0, 1]$$

Con el propósito de obtener el término $\frac{\partial \theta_i}{\partial q_j}$, se pre multiplicarán ambos lados de la ec. (f.2) por $\mathbf{J}_{\theta_i}^{-1}$, finalmente se obtiene:

$$\frac{\partial \theta_i}{\partial q_j} = \mathbf{J}_{\theta_i}^{-1} \mathbf{J}_{q_i} \frac{\partial \mathbf{q}}{\partial q_j} \quad (\text{f.3})$$

Apéndice G

Trayectoria helicoides compuesta

Esta trayectoria se compone de tres subtrayectorias, cada una de estas con un perfil quintico, que son:

Una recta con puntos de posición y orientación inicial y final:

$$\begin{aligned} p_i &= [0, 0, -0.419][m] & p_f &= [0.2, 0, -0.5][m] \\ \beta_i &= [0, 0, 0][^\circ] & \beta_f &= [20, 5, 0][^\circ] \end{aligned}$$

Un helicoides con las siguientes ec. paramétricas:

$$\begin{aligned} R &= [0.2\cos[3\pi s], 0.2\sin[3\pi s], -0.5 + 0.15s][m] \\ \beta &= [20s, 25 - 20s, 0][^\circ] \end{aligned}$$

Una recta con puntos de posición y orientación inicial y final:

$$\begin{aligned} p_i &= [0.2, 0, -0.35][m] & p_f &= [0.2, 0, -0.5][m] \\ \beta_i &= [20, 5, 0][^\circ] & \beta_f &= [0, 0, 0][^\circ] \end{aligned}$$

Se hace notar que las rectas se generaron de la misma forma que en el Apéndice B y que para obtener la velocidad y aceleración del helicoides, se derivaron una y dos veces respectivamente las ecuaciones de posición y orientación (R y β). En la Figura G.1. se muestra la trayectoria del helicoides compuesto.

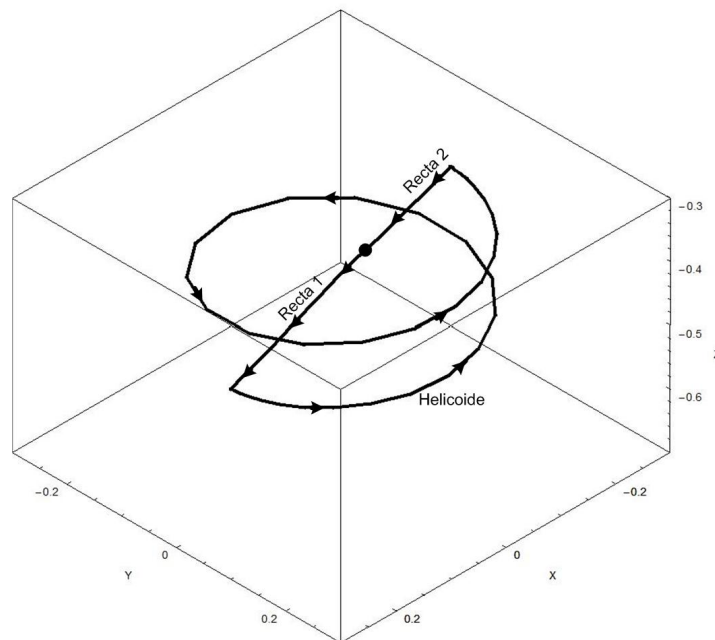

Figura G.0.1. Trayectoria "Helicoides compuesto"