



**UNIVERSIDAD NACIONAL AUTÓNOMA DE MÉXICO**  
PROGRAMA DE MAESTRÍA Y DOCTORADO EN INGENIERÍA  
INGENIERÍA CIVIL – CONSTRUCCIÓN

***SUBMERGED FLOATING TUNNEL: A SOLUTION PROPOSAL FOR THE PROBLEMS OF  
COMMUNICATION AND DEVELOPMENT OF THE BAJA CALIFORNIA PENINSULA IN THE  
NORTHWEST OF MEXICO***

TESIS QUE PARA OPTAR POR EL GRADO DE:  
MAESTRO EN INGENIERÍA

PRESENTA:  
ING. JOAQUIN OMAR PANDURO NORIEGA

TUTOR:  
M.I. MARCO TULIO MENDOZA ROSAS

MÉXICO, D. F. NOVIEMBRE, 2013



*To my parents for the great effort that  
they have done during my studies and their  
invaluable support that they gave me along my way*





## *Acknowledgments*

To the *Universidad Nacional Autonoma de Mexico* for the opportunity of being part of the postgraduate program of engineering. The acquired knowledge is fundamental in my formation as Civil Engineer.

To the Consejo Nacional de Ciencia y Tecnologia (CONACYT) for the scholarship provided during the master studies as well as the extra support awarded for doing a visiting research in Italy.

To each one of the professors who taught me their knowledge during the masters courses. I thank you for the formation and criteria obtained during the program.

To the committee for the revision of this thesis project. Thanks all you for accepting being part of this work.

- M.Eng. Marco Tulio Mendoza Rosas
- Eng. Ernesto René Mendoza Sanchez
- M.Eng. Jesús Antonio Esteva Medina
- M. Eng. Hector Juvencio Lopez Gutierrez
- M.Eng. Luis Candelas Ramírez

To the professor Dr. Eng. Federico Mazzolani for the opportunity of introduce me in the world of the Submerged Floating Tunnels. For giving me the opportunity to realize a visiting research at the University of Naples Federico II, as well as all the facilities and time spent during the stay. Infinite thanks.

To the professor Dr. Eng. Beatrice Faggiano for the time spent during the stay at the University of Naples Federico II and for making me give my best at work. Take decisions with arguments I owe to you.

To the great engineer and first tutor that I had in my master program. To the Eng. Carlos Manuel Chavarri Maldonado (†) for his support and the experience transmitted during the meetings.

To the coordinator of the Master in Construction and my Thesis Director. Thank M.Eng. Marco Tulio Mendoza Rosas for the opportunity of entry in the program and support me during it.

To all my partners and persons who were part of my life during my master studies. Thanks for the great moments lived.



# Content

<b>RESUMEN:</b> .....	<b>11</b>
<b>ABSTRACT:</b> .....	<b>13</b>
<b>INTRODUCTION</b> .....	<b>15</b>
<b>CHAPTER 1. THE STATE OF THE ART OF SUBMERGED FLOATING TUNNELS.....</b>	<b>16</b>
1.1. THE SUBMERGED FLOATING TUNNEL CONCEPT .....	16
1.1.1. <i>History of the SFT</i> .....	17
1.1.2. <i>Proposals around the world</i> .....	18
1.2. TYPOLOGY OF SFT .....	20
1.2.1. <i>SFT self supported</i> .....	21
1.2.2. <i>SFT with anchorage system</i> .....	21
1.2.3. <i>SFT with pontoon system</i> .....	22
1.2.4. <i>SFT supported on piers</i> .....	23
1.2.5. <i>SFT with combined system (anchorage and pontoons)</i> .....	24
1.2.6. <i>Combination of SFT with others structures</i> .....	25
1.2.6.1 SFT with immersed tunnels .....	25
1.2.6.2. SFT with bridges.....	25
1.2.6.3. SFT with floating bridges .....	26
1.3. STRUCTURAL ELEMENTS FOR SUBMERGED FLOATING TUNNELS.....	27
1.3.1. <i>Cross sections typology</i> .....	27
1.3.2. <i>Materials</i> .....	29
1.3.3. <i>Support system</i> .....	31
1.3.3.1. Pontoons.....	31
1.3.3.2. Foundations .....	32
1.3.3.2.1. Gravity foundation.....	33
1.3.3.2.2. Piers .....	33
1.3.3.2.3. Rock bolts.....	37
1.3.3.2.4. Suction caissons .....	38
1.3.4. <i>Linking system</i> .....	38
1.3.4.1. Cable system.....	39
1.3.4.2. Tension Leg Platform (TLP) .....	40
1.3.5. <i>Joints</i> .....	42
1.3.5.1. Inter-module joint .....	42
1.3.5.1.1. Flexible joints .....	42
1.3.5.1.2. Rigid joints .....	44
1.3.5.2. Shore joint .....	46
1.3.6. <i>Access structure</i> .....	49
1.3.7. <i>Evacuation Towers</i> .....	52
1.4. STRUCTURAL DESIGN REQUIREMENTS .....	53
1.4.1. <i>Load conditions</i> .....	56
1.4.1.1. Permanent loads.....	56
1.4.1.2. Variable loads .....	57
1.4.1.3. Environmental loads .....	57
1.4.1.3.1. Hydrodynamic loads .....	57

1.4.1.3.2. Seismic loads.....	60
1.4.1.3.3. Tsunamis.....	61
1.4.1.4 Exceptional events.....	61
1.4.2. <i>Structural model solution</i> .....	62
<b>CHAPTER 2. DESIGN REQUIREMENTS FOR ROAD TUNNELS .....</b>	<b>65</b>
2.1. TYPOLOGY .....	65
2.1.1. <i>Land Tunnel</i> .....	66
2.1.2. <i>Subsea Tunnels</i> .....	67
2.1.3. <i>Immersed Tunnels (IMT)</i> .....	67
2.2. EXISTING TUNNELS AROUND THE WORLD.....	67
2.2.1. <i>Rail Tunnels</i> .....	67
2.2.2. <i>Road Tunnels</i> .....	73
2.2.3. <i>Immersed Tunnels</i> .....	80
2.3 DESIGN REQUIREMENTS .....	87
2.3.1 <i>Codes around the world</i> .....	88
2.3.2. <i>Cross-Section geometry</i> .....	89
2.3.3 <i>Structural measures</i> .....	94
2.3.3.1 Emergency exit for users .....	94
2.3.3.2 Emergency access for rescue staff.....	94
2.3.3.3 Drainage of flammable liquids.....	96
2.3.4 <i>Safety equipment</i> .....	97
2.3.4.1. Ventilation .....	97
2.3.4.2. Lighting .....	98
2.3.4.3. Signage .....	99
2.3.4.4. Communication and alarm systems.....	100
2.3.4.5. Traffic regulation - monitoring equipment.....	102
2.3.4.6. Fire Fighting System.....	103
2.3.4.7. Power supply .....	104
2.3.5 <i>Additional issues</i> .....	105
2.4. CONSTRUCTION SYSTEMS FOR IMMERSED TUNNELS .....	106
2.4.1 <i>Steel Immersed tunnel</i> .....	107
2.4.1.1. Materials and fabrication of steel shells.....	108
2.4.1.2. Launching of tubes.....	108
2.4.1.3. Placing of concrete .....	109
2.4.1.4. Tube transport.....	110
2.4.1.5. Immersing process.....	111
2.4.1.6 Joints between elements.....	111
2.4.1.7 Land connection .....	113
2.4.2 <i>Concrete Immersed Tunnel</i> .....	113
2.4.2.1 Element production .....	114
2.4.2.1.1 Monolithic production .....	114
2.4.2.1.2 Segmental production .....	114
2.4.2.2 Transport of elements .....	116
2.4.2.3 Immersing process.....	117
2.4.2.4 Joints between elements.....	117
<b>CHAPTER 3. ENVIRONMENTAL CONDITIONS IN THE GULF OF CALIFORNIA .....</b>	<b>118</b>
3.1 GENERALITIES OF THE GULF OF CALIFORNIA.....	118

3.1.1. Environmental data for marine structures.....	119
3.2 BATHYMETRY .....	120
3.3 GEOLOGY .....	121
3.3.1 Type of ground.....	121
3.3.2 Geological faults.....	125
3.3.3 Seismicity.....	128
3.4 WATER TEMPERATURE .....	130
3.5 WINDS.....	133
3.6 CURRENTS .....	135
3.7 TIDES.....	138
3.8 WAVES .....	139
3.9 METEOROLOGICAL PHENOMENA .....	141
3.10 SHIPPING IN THE GULF OF CALIFORNIA .....	142
3.11 NATURAL PROTECTED AREAS.....	143
<b>CHAPTER 4. CONCEPTUAL DESIGN OF THE SFT IN THE GULF OF CALIFORNIA .....</b>	<b>145</b>
4.1. LOCATION OF THE SFT .....	145
4.1.1. Selection Criteria.....	146
4.1.2. Seabed sections.....	146
4.1.2.1. Longitudinal sections.....	146
4.1.2.2. Transversal sections.....	148
4.1.3. Evaluation of natural conditions at the location.....	156
4.1.3.1. Bathymetry.....	157
4.1.3.2. Type of ground .....	157
4.1.3.3. Seismicity.....	157
4.1.3.4. Water Temperature.....	158
4.1.3.5. Wind .....	158
4.1.3.6. Currents.....	159
4.1.3.7. Tides .....	160
4.1.3.8. Waves .....	160
4.1.3.9. Meteorological Phenomena .....	160
4.1.3.10. Shipping in the region.....	161
4.1.3.11. Natural Protected Areas .....	161
4.1.4. Comparison of the definitive location with others SFT locations proposed around the world ....	162
4.2 GEOMETRY OF THE CROSS-SECTION.....	165
4.2.1. Standard Cross-Section .....	165
4.2.2. Special Cross-Section.....	168
4.2.3. Transition cross-section .....	171
4.3. STRUCTURAL DESIGN ISSUES.....	171
4.3.1 Materials.....	171
4.3.2 Loads.....	172
4.3.3. Anchorage system.....	175
4.3.3.1. Connection Details.....	176
4.3.4. Foundations .....	177
4.3.5. Joints.....	179
4.3.5.1. Inter-modular joints.....	179
4.3.5.2. Shore Connections.....	180
4.3.6. Access Structure.....	181

4.3.7. Towers and service platform.....	185
4.4 SAFETY.....	188
4.4.1 Structural measures.....	188
4.4.1.1. Road lanes .....	192
4.4.1.2. Parallel escape tube.....	192
4.4.1.3. Emergency exits.....	192
4.4.1.4. Cross-passage .....	192
4.4.1.5. Emergency lane .....	193
4.4.1.6. Turning points.....	193
4.4.1.7. Shelters.....	193
4.4.1.8. Emergency services .....	193
4.4.1.9. Drainage system .....	193
4.4.2 Safety equipment.....	194
4.4.2.1. Ventilation .....	194
4.4.2.2. Lighting .....	195
4.4.2.3. Signage .....	195
4.4.2.4. Water supply .....	196
4.4.2.5. Alarm system .....	196
4.4.2.6. Communication .....	197
4.4.2.7. Traffic regulation - monitoring equipment .....	197
4.4.2.8. Power supply .....	197
4.4.2.9. Mental stress .....	198
4.5 SKETCHES .....	199
<b>CONCLUSIONS.....</b>	<b>202</b>
<b>REFERENCES.....</b>	<b>206</b>



UNIVERSIDAD NACIONAL AUTÓNOMA DE MÉXICO  
DIVISIÓN DE ESTUDIOS DE POSGRADO  
FACULTAD DE INGENIERÍA



---

*Túnel Flotante Sumergido: Una propuesta de solución a los problemas de comunicación y desarrollo de la península de Baja California en el noroeste de México*

**Joaquín Omar Panduro Noriega**

*Tesis de maestría*

*Departamento de Construcción*

*División de Ingenierías Civil y Geomática*

*Ciudad Universitaria, México DF, 2013*

---

## **Resumen:**

El desarrollo de nuevas técnicas para cruzar estrechos es una tarea de todos los días alrededor del mundo. Hoy en día, se han llevado a cabo distintas soluciones de cruce tanto en montañas como en cruces acuáticos. Sin embargo las mayores dificultades se presentan cuando se intenta cruzar estrechos con aguas profundas y de grandes longitudes. Puentes o Túneles Sumergidos han sido la solución más común para estos casos, pero desafortunadamente, en ocasiones no es factible su empleo. Por lo que nuevos desarrollos de solución a estos cruces se han venido estudiando.

Una nueva solución de cruce es el Túnel Flotante Sumergido (SFT) que actualmente está bajo desarrollo en algunos países. Este ha sido considerado como una solución ideal para cruces acuáticos profundos y largos. La implementación de esta solución cada vez es más cercana debido al mejoramiento de la ingeniería costa-afuera. Una realidad es que la solución representa muchas ventajas contra las estructuras convencionales de cruces acuáticos. El SFT por sus siglas en inglés es más amigable con el ambiente que estructuras convencionales, es más barato después de ciertas distancias y además puede ser empleado donde una estructura convencional no podría emplearse.

El hecho es que hasta el día de hoy no existe ningún Túnel Flotante Sumergido en el mundo. En años pasados fue intentado construir un prototipo de 100m de longitud en el Lago Qiandao en China, sin embargo debido a algunos problemas extra técnicos no fue posible hacerlo realidad. Más aún, muchos países han propuesto un SFT como solución de cruce acuático en sus territorios.

Por otra parte, el objetivo del presente trabajo es proponer un SFT como solución de cruce en el Golfo de California en el noroeste de México. Es pensado que si este cruce fuera realizado, se mejoraría la calidad de vida de la región de la península de Baja California. El trabajo puede ser resumido en cuatro capítulos principales. Primeramente, es abordado el concepto de Túnel Flotante Sumergido. Incluyendo la idea original, historia, tipología, así como algunas características estructurales y condiciones de carga. Además, debido a la gran longitud que representa cruzar el Golfo de California, fue necesario estudiar los requerimientos para el diseño de túneles carreteros. Por lo tanto, en el segundo capítulo son estudiados manuales de diferentes países del mundo. Adicionalmente son estudiados los proyectos actuales de túneles carreteros incluyendo las soluciones más innovadoras para los distintos túneles alrededor del mundo, con el propósito de adaptar las soluciones al SFT propuesto en este trabajo. Para el tercer capítulo, se llevó a cabo un estudio de las condiciones ambientales del Golfo de California. Han sido recolectados datos necesarios para el diseño de estructuras marinas tales como temperatura, batimetría, viento, oleaje, corrientes, características geológicas, entre otras. La información es obtenida de instituciones gubernamentales y universidades de México. Por otra parte, el capítulo cuatro está enfocado en el diseño conceptual del SFT. Se lleva a cabo el diseño de los diferentes componentes que involucra

un SFT, tales como la sección transversal del túnel, cimentación, sistema de anclaje, estructura de acceso, entre otros. Adicionalmente se encuentra el diseño de la seguridad del SFT, la cual representa un verdadero desafío en el diseño debido a la gran longitud del cruce.

En conclusión, este trabajo es una propuesta preliminar donde fueron tocados los principales componentes de un proyecto de Túnel Flotante Sumergido. En el diseño de los diferentes rubros son explicados los criterios previamente establecidos. Así, la solución final involucra todos los criterios establecidos para el diseño. El hecho es que la propuesta final representa la solución óptima de acuerdo al conocimiento actual sobre la tecnología de SFTs.





UNIVERSIDAD NACIONAL AUTÓNOMA DE MÉXICO  
DIVISIÓN DE ESTUDIOS DE POSGRADO  
FACULTAD DE INGENIERÍA



---

---

***Submerged Floating Tunnel: a solution proposal for the problems of communication and development of the Baja California peninsula in the northwest of Mexico.***

**Joaquin O. Panduro**

*Thesis*

*Master Student*

*Department of Construction at the Postgraduate Studies Division at the Faculty of Engineering, Ciudad Universitaria, México DF, 2013.*

---

---

**Abstract:**

Around the world the development of new techniques to cross straits is a daily task. Nowadays many crossing solutions have been executed in difficult crossings either in mountains or water crossings. However, the most difficulties occur when is attempted to cross a wide and deep water crossings. Bridges or Immersed Tunnels are the most common solution in these cases, but unfortunately, in some cases these solutions are unfeasible. Thus new develops of crossing solutions have been studied.

Nowadays, The Submerged Floating Tunnel (SFT) is a new crossing solution under development in many countries. It is considered a suitable solution for wide and deep water crossings. The improvement of offshore engineering has provided many tools for doing reality the SFT in a near future. A fact is that this solution has many advantages against conventional structures for water crossings. SFTs are environmentally friendlier than conventional structures, cheaper after certain distance and also can be employed where no other conventional structure could be realized.

A fact is that it does not exists any Submerged Floating Tunnel in the world. In past years, it was attempted to build a prototype of 100 m. in the Qiandao Lake in China, however due some extra technique problems it was not possible make it reality. Furthermore, many countries have proposed a SFT as solution for a water crossing in their territory.

Moreover, the objective of the present work is proposed a SFT as solution for crossing in the Gulf of California, in the northwest of Mexico. It is thought, that if this crossing is done the development of the Baja California peninsula could improve, consequently it would increase the whole life quality of the region. The work can be summarized in four main chapters. Firstly, is boarded the concept of Submerged Floating Tunnels, including the original idea, history, typology, some structural features and loading conditions. Moreover, the great length that represents crossing the Gulf of California, it was necessary to study the requirements for the design of road tunnels. Thus, in the second chapter is studied the different regulations around the world for road tunnels. Furthermore are studied the current road tunnels and also the most modern innovations for tunnels in different projects in the world in order to adapted to the SFT proposed in this work. By the third chapter, an investigation of natural conditions in the Gulf of California has been held. It is collected all the data necessary for the design of marine structures such as temperature, bathymetry, wind, wave, currents, geological characteristics, and so on. The information is collected from government institutions and universities from Mexico. Moreover, the fourth chapter is focus on the conceptual design of the SFT. It is carried on the design of the different issues that involve a SFT such as the tunnel cross-section, foundation, anchorage system, access structure, and so on. In addition it is design the safety in the SFT, what is a really challenge due the great length of the crossing.

In conclusion, this work is a preliminary proposal where is touched each one of the main issues of any Submerged Floating Tunnel project. In design of the different designed aspects are explained the different criteria previously established. Thus, the final solution involves all the criteria established for the design. A fact is that the final proposal represents the optimal solution according the current knowledge about SFT technology.

## Introduction

In this work the Submerged Floating Tunnel (SFT) technology is studied in order to apply it to crossing the Gulf of California. Firstly, in chapter one the general explanation about the Submerged Floating Tunnel is provided as a new waterway crossing solution. It content information about the history of SFT as well as the solutions that have been proposed around the world. The different configurations of SFT are explained either the most typical proposals as the most modern ones, and also the combination with conventional crossing structures. Moreover, the structural components of a Submerged Floating Tunnels are explained, including design aspects as loading condition and structural requirements for modeling. This chapter contains the most update information of the SFT technology based on the most recent conferences in the field (6th symposium of Strait Crossing).

In the chapter two is carried on a deep study about tunnels. A fact is that the SFT proposed in this work is so far from the current tunnel projects in the world. Thus, the focus of the chapter is the tunnel safety as well as the design requirements for the different typology of tunnels. Thereby, in the design of the Submerged Floating Tunnel of this work can be adopted the most suitable criteria for tunnels around the world. The information in this chapter has been collected from the different codes from the countries with more experience in tunnels. Also are studied the most modern tunnel projects where can be find many innovations in the field. All the collected information is adapted to the design of the SFT in the chapter four of this work.

The Chapter three contains all the environmental condition of the Gulf of California. All the information has been collected from some academic institution as well as government divisions. In some cases the data was collected from international research programs. The source of this information is explained en each feature of the environmental condition. The achieve of this chapter is evaluate the natural conditions in the whole Gulf of California for later choice the suitable location for the Submerged Floating Tunnel according the established criteria.

Moreover, the chapter four which is the core chapter of the thesis project contents the conceptual design of SFT. The knowledge acquired of all the previous chapters of the work is applied. Firstly, it is choice the suitable configuration of SFT among the different solutions studied in chapter one. Secondly, the many regulations of tunnels from chapter two are adapted to the Submerged Floating Tunnels in order to provide a safety solution despite the great length that it represents. Furthermore, the data collected to forming the chapter three is evaluated it in order to choice the suitable solution for placed the SFT. By this way all the chapters of the thesis project are linked at the four chapter of the work. In general, the solution given for the SFT of the work involves:

- The Establishment of the location of the SFT which depends of the evaluation of the natural conditions in the Gulf of California from chapter three.
- The geometry design of the cross section according the tunnel requirements from chapter two.
- The structural design of the main components of the SFT from chapter one.
- The safety considerations in the Submerged Floating Tunnel proposed from chapter two.

# Chapter 1

## The state of the art of Submerged Floating Tunnels

### 1.1. The Submerged Floating Tunnel Concept

A Submerged Floating Tunnel (SFT) is a new waterway crossing structure which concept has been proposed around the world. The solution has been adopted principally for strait crossings where its application acquires many advantage against conventional structures. The SFT is also named Archimedes Bridge, Suspended Tunnel or Submerged Floating Tube. As the name suggest, it is basically a tube-like structure floating at some depth in the water, where the tube is large enough to accommodate road and/or rail traffic. As any structure that is floating in water, it must be moored or fixed against excessive movements. In The Figure 1.1 can be appreciated the SFT concept as well as the conventional solution employed for waterway crossing.

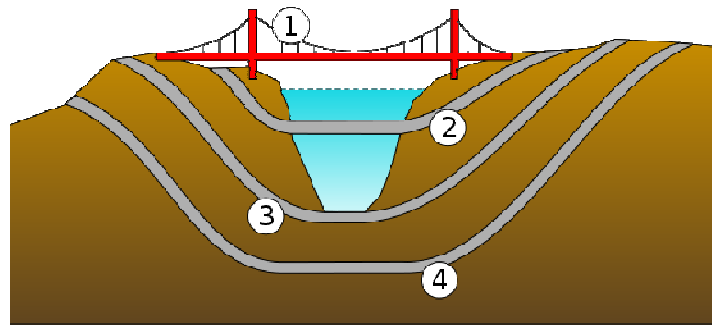

Figure 1.1 Waterway crossing solutions. (1) Cable stayed bridge; (2) Submerged Floating Tunnel; (3) Immersed Tunnel; (4) Subsea tunnel. (SIJLAB, 2007)

The essence of the SFT is the Archimedes Principle<sup>1</sup>. It consists in a continue structure with regular cross-section which is submerged in the water at a specific depth. Then the buoyancy of the structure created for the displaced volume trend to go upward when the buoyancy is larger than the weight of the structure. On the other hand, when the weight is larger than the buoyancy, the structure goes downward of the crossing. It depends of the crossing conditions and criteria of the designers if the SFT works with positive or negative residual buoyancy.

Whatever the residual value of the buoyancy on the SFT is, many solution for the different proposals around the world has been created. When the SFT goes up, gravity foundations and diverse type of anchorage system has been adopted. Moreover, when the structure trend to go down, many systems as pontoons on the surface or piers on the seabed has been proposed (Figure 1.2).

---

<sup>1</sup> The buoyant force on an object is equal to the weight of the fluid displaced by the object, or the density of the fluid multiplied by the submerged volume times the gravitational constant,  $g$ .

A fact is that others features related to the SFT conditions might be considered. Natural conditions where the structure is located are the issues that usually governed the project. The environment of the location transfers the different motions to the structure, so the SFT must be able for absorbing the forces that the environment transfers. Thereby, different solutions for the diverse cases have been proposed.

In addition, other components of the SFT are important for an adequate behavior. Issues as access structures, foundation, joint between elements, shore connection and so on, play a vital role of the whole conjunct.

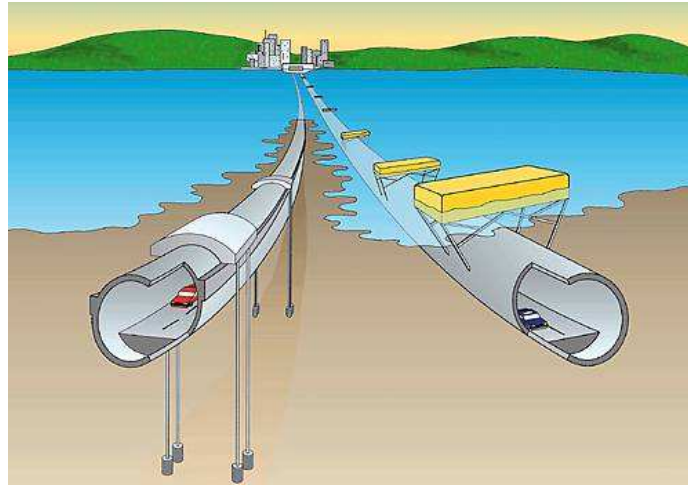

Figure 1.2 General solutions for SFT (UBC)

#### 1.1.1. History of the SFT

The first idea of Submerged Floating Tunnels as a waterway strait crossing system dates back to the first decade of the Twentieth Century, in Norway (Hakkart, 1996). It emerged as a solution for very long and depth water crossing. This case is common in many cases in the Scandinavian country. It is presented in the lots of fjord<sup>2</sup> located at the western coast of the Viking country.

In the last thirty years, the great improvements achieved in offshore and deep sea technologies have allowed to solve the numerous problems that hampered the realization of this kind of structure, so that several preliminary designs and feasibility studies have been proposed in the last years (Martire, 2010). Furthermore, the immersed tunnel technology has been improved in the latest projects and longer tunnels have created as well as located in more complex conditions, where some years ago would not be considered. Thus, many proposals of SFT around the world have been studied, being the first application in marine conditions when the depth is too large for a conventional structure.

In 1983, it was established in Italy the first research group for the development of the SFT named *Ponte di Archimedes International S.p.A.* Many scientific institutions as wells as important universities where involved in the study and creation of the SFT technology. At the beginning the international cooperation was composed by the Norwegian Roads Research Laboratory, Danish Road Institute, Italian Shipping Register with the Forum European Highways Research Laboratories and the European Union as sponsors.

---

<sup>2</sup> A Fjord is a long, narrow inlet with steep sides or cliffs, created in a valley carved by glacial activity.

In 1998, it was created the Sino-Italian Joint Laboratory of Archimedes Bridge (SIJLAB) between the Institute of Mechanics, Chinese Academy of Sciences, China and Ponte di Archimede S.p.A.. It was financed by the Italian Ministry of Foreign Affairs, the Chinese Ministry of Science and Technology and the Institute of Mechanics of the Chinese Academy of Sciences. The consortium was as goal building a 100m AB prototype in Qiandao Lake in China in the eastern province of Zhejiang.

On 2004 the tunnel option was more widely discussed, especially when Kwik Kian Gie, then the Minister of National Development announced that a European consortium was interested in investing in the undersea tunnel between Java and Sumatra. The budget was told to be around 15 billion US dollars for the undersea tunnel in the Sunda Strait; in long term it would link up Bali, Java, Sumatra, Malaysia and Thailand in an uninterrupted chain. The project was planned to start construction in 2005 and be ready to use by 2018, and was a part of the Asian Highway.

In 2007, Indonesian experts, led by Ir. Iskendar, Director for the Center of Assessment and Application of Technology for Transportation System and Industries, participated in a meeting with SIJLAB engineers, from the Sino-Italian Archimedes Bridge project. As an archipelagic country, consisting of more than 13 thousand islands, Indonesia could benefit of such tunnels. The conventional transportation service between islands is made mainly by ferries.

In 2008 the possibility to cross the Huang Pu River in Shangai (PR of China) by means of an Archimedes Bridge was also investigated. The AB would have served as a pedestrian passage allowing the visitors of the Expo 2010 to quickly cross the river. The area of the Huang Pu River selected for the SFT is characterized by an average width (corresponding to the span to be covered) of 400 m and an average depth of 12 m. Based on the weight of the largest ships which could be present in the river, a minimum depth equal to 8 m was estimated for the free surface navigation.

A fact is that no Submerged Floating Tunnel has been realized until the moment. Some projects around the world are in the planning phase. The more advanced are the realized for the Norway, Korea and China.

### 1.1.2. Proposals around the world

With the improvement of the SFT field many countries around the world have adopted this strait crossing solution. From being just a conceptual idea in the past, nowadays, is becoming in a reality solution.

The many advantages as well as the applications that a SFT represents, has led to increase the interest in this technology. Many institutions and universities have been given the task to create guidelines for the SFT design. However, at the moment no standardized criteria in the world have been adopted.

In the different worldwide proposals diverse SFT solutions have the presented. There are varied criteria in the conceptual design as used material, cross section shape, typology of anchorage or pontoons, safety design and so on.

The distinct Submerged Floating Tunnels proposed in the different continents in the world are summarized in the table 1.1

Country	Location of the SFT
<b>Norway</b>	Many fjords; <i>Sognefjord, Hogsfjord</i>
<b>Sweden</b>	Vattern Lake

<b>Italy</b>	Messina strait; Alpine lakes
<b>Greece</b>	Connection between the islands and mainland
<b>Turkey</b>	Connection between the islands and mainland
<b>Spain-Morocco</b>	Strait of Gibraltar
<b>Portugal</b>	Tejo
<b>France</b>	Gironde
<b>France-Switzerland</b>	Lake Geneva
<b>Germany-Austria-Switzerland</b>	Lake Constance
<b>Switzerland</b>	Lakes: Neuchatel, Lucerne; Zurich
<b>USA</b>	Fjords of the west coast
<b>Alaska-Russia</b>	Bering Strait
<b>Canada</b>	Fjords of the west coast
<b>China</b>	Southern islands
<b>South east of Asia</b>	Connection between the islands and mainland
<b>Korea</b>	Connection between the islands and mainland
<b>Mexico</b>	Gulf of California

*Table 1.1 SFT proposals around the world (FEHLR, 1996)*

In recent years many feasible studies have been realized to connect the different islands of the country. The Table 1.2 borrow from the work of Shunji (2010), shows the features of this proposals.

Name of project	Location	Purpose	Length (m)	Max. Water depth (m)
Funka Bay Crossing	Bay threshold	Motor vehicle Railroad	30,000	120
Toya Lake crossing	Lake crossing	Pedestrian Mono-rail	3,000	100
Rishiri Rebun Crossing	Strait Crossing	Lifeline Transportation system	22,000	200
Ishikariwan Shinko In-port Crossing	In-port Crossing	Motor vehicle	972	15
Daikokujima Crossing	In-port Crossing	Pedestrian	120	10
Soya Strait Crossing	Strait Crossing	Motor Vehicle Railroad	43,000	180
Otaru In-port Crossing	In-port Crossing	Pedestrian	300	10
Okinawa-Ie island Strait Crossing	Strait Crossing	Motor Vehicle	3,000	150

*Table 1.2 Major feasibility studies done by the society of SFT research in Hokkaido, Japan (Shunji, 2010)*

It is important to remark, that there is another important proposal which is most relevant from the point of view of the study. This is an AB prototype that was attempted to build on the Qiandao Lake in China during the 2010. However, for some political reasons as well as sponsors involved in the project it could not be realized until the moment. This prototype would be undoubtedly a starting point for the SFT technology for continue improving and realizing the other ideas that are around the world.

From the point of view of the author, a fact is that while a SFT prototype would not be constructed for it behavior study in real conditions, a mega project as the considered in the rest of the world would not be realized. It would not be invested large amounts of money in unsafe or unreliable structures.

## 1.2. Typology of SFT

As any other structure for waterway crossings are different solutions to be chose in order to optimize for each case. The same situation presents the configuration of a Submerged Floating Tunnel. The design of this kind of structure depends of many factors which are directly linked to the configuration. Here below are listed the most important for the selection between the typology of SFT.

- a. The depth and width of the crossing
- b. The environmental conditions. Principally: waves, winds, currents, meteorological phenomena impact.
- c. The shipping in the location. Clearance at the surface.
- d. Destine of the SFT. Pedestrian, motorways, railway.

Thus, once that are analyzed the conditions which surrounds the crossing, the first step for the typology section is decided if the SFT will work with a positive or negative residual buoyancy. After that, the rest of the many structural issues are designed. It means that if the structure works with positive buoyancy, it requires the design of foundation whatever the type would be, including the cable systems and so on. In the case that the tunnel works with negative buoyancy, the design of pontoons and mooring system will be requires. Whatever the residual buoyancy is, the design of the supporting system must be able of resist the maximum value within the design limits. Moreover, it must keep the SFT on it position despite the waves or currents even when some natural phenomena are present as tsunamis or earthquakes.

The main typology of SFT it is shown in the chart of the Figure 1.3

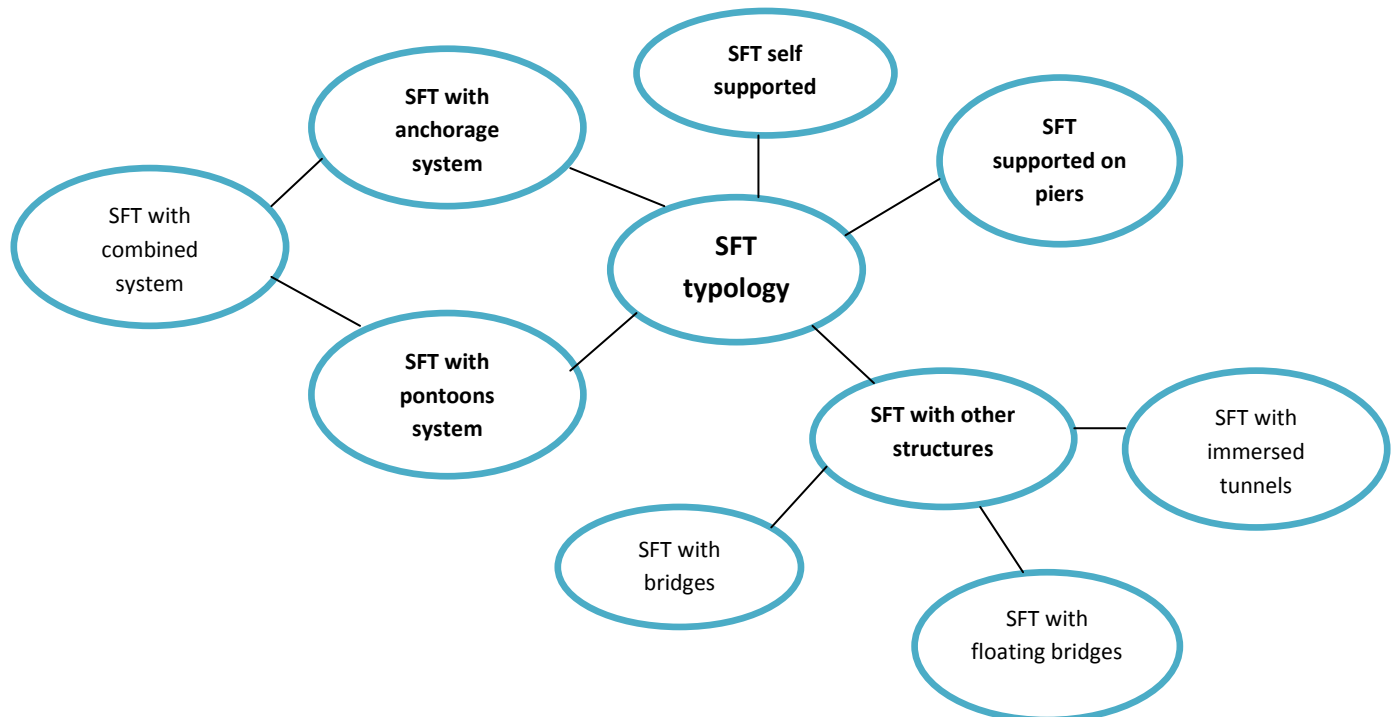

Figure 1.3 General typology of Submerged Floating Tunnels



### 1.2.1. SFT self supported

It can be considered as the useless Submerged Floating Tunnel. Its application is limited to crossings with a small length in comparison to the other types. Furthermore, it must be placed where the natural environment is really friendly.

In this kind of SFT, the self weight of the structure might meet the buoyancy of it. It means that values of around zero must be looked. This condition is important in order to avoid any residual internal force which can damage the structure during their life. In Figure 1.1(2) can be appreciate the configuration of a SFT self supported

### 1.2.2. SFT with anchorage system

Generally is the traditional solution for the Submerged Floating Tunnel concept. It is a suitable solution when it is necessary to provide an efficient lateral support due to severe environmental conditions or in deepwater crossings. It is applied when the buoyancy of the structure is larger than its own weight. It means that the tunnel tends to emerge to the surface. So, for absorbing the residual buoyancy of the SFT, a conjunct of foundation and anchorage system is necessary.

For the anchorage system the proposal of steel cables or steel tubes as tethers is the most common practice. It is required that slack should never occur in the tethers, consequently the SFT must have sufficient net buoyancy under any load, wave, current, salinity or temperature condition in order to avoid any foul in the structure. On the other hand it is preferable to minimize the anchor forces (Skorpa, 2010). Figure 1.4.

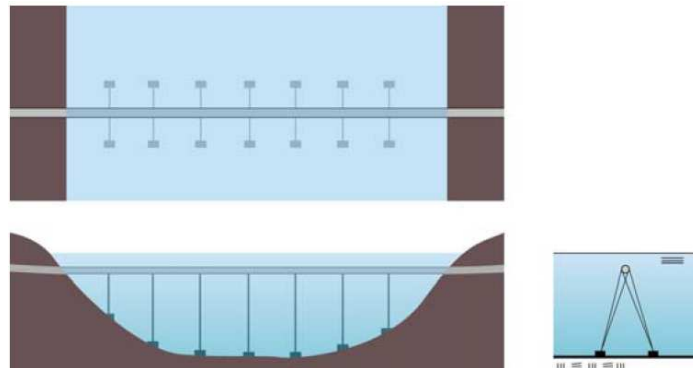

Figure 1.4. SFT with anchorage system. (Skorpa, 2010)

With respect to rigid tubular members, cables seem to be preferable as they feature a negligible bending stiffness and thus they are not subjected to the considerable stress increments induced by biaxial bending in the tubular members. Moreover, many technological drawbacks related to the use of tubular members, such as manufacturing problems due to the large thickness, imperfections, specific controls to test the quality of the welded joints, transport and installation difficulties, would be avoided (Faggiano and Mazzolani, 2001).

In general, the advantages that offer the SFT with anchorage system as solution are:

- No restrictions to ship traffic and represents no collision risk for ships
- No visible parts above water
- Easier installation of additional measures, such as tethers, to cope with possible unforeseen behavior

- Eliminates slowly varying dynamic response
- Less excited by first order wave forces
- Less excited by wind and current
- Probably less complicated dynamic response including less torsional excitations
- Safer and less costly installation of tube since the tethers can be used as mooring systems during installation
- May have both straight and curved horizontal alignment

### 1.2.3. SFT with pontoon system

It is a suitable solution for deepwater crossings as it no depends of the depth of the crossing. Even with large length this solution can be employed. In this case the permanent weight of the structure exceeds the buoyancy value, in consequently the SFT tents to sink. Thereby, a group of pontoons on the surface are necessary for support the negative residual buoyancy of the SFT. Figure 1.6.

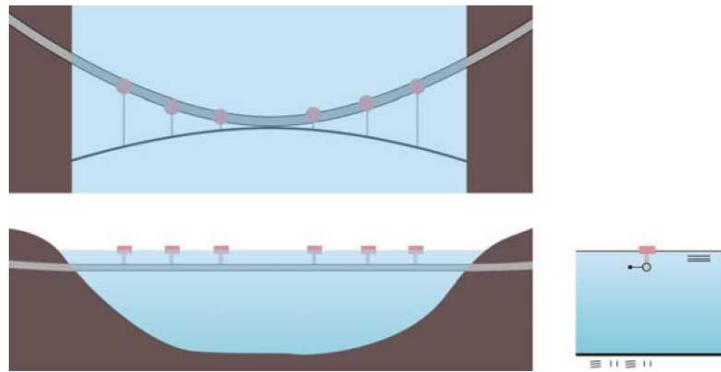

Figure 1.5. SFT with pontoons system (Skorpa, 2010)

An adverse point of this configuration is that pontoons are directly impact for the environmental conditions. Therefore, is not a recommendable solution when severe natural conditions are present in the water crossing. High values of waves, winds or high possibility of hurricane impacts are a hazard for the general structure. Furthermore, the pontoons follow the tide movement; therefore, to be able to tolerate these changes, the structure must provide the flexibility required to prevent fouts. Some additional solutions to avoid exceeding the allowable movements of the structure, can be used at the seabed with anchors, linked to work only when these limits are exceeded.

- a. Curve the SFT like an arch in the horizontal profile (Figure 1.5).
- b. Have continuous tension tether from shore to shore, curved contra wise to the SFT, and with connecting tethers to the SFT (Figure 1.5).
- c. Combine two parallel tunnels connected every inter-axis distance where also the pontoons are connected to the both tunnels of the SFT (Figure 1.6)

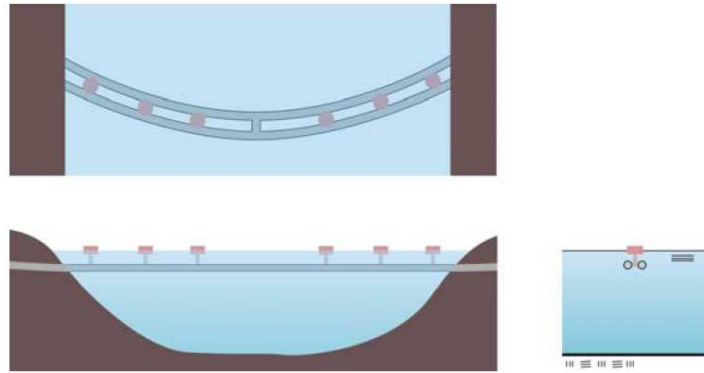

Figure 1.6 SFT with pontoons system and two tubes configuration (Skorpa, 2010)

It is important provide the required clearance between pontoons for allowing the free passage of ships in these gaps.

In general advantages than the solution of SFT with pontoons can be listed here below:

- Eliminates uncertainties with respect to the subsea soil conditions
- No costly and risky foundations or anchoring points at the seabed in deep waters
- Less vulnerable to underwater land-slides
- Less vulnerable to collision by submarines
- No tethers that may be subjected to instability phenomena
- Less subjected to excitation by earthquakes

#### 1.2.4. SFT supported on piers

This typology of Submerged Floating Tunnel is also called for some author as Immersed Bridge Tunnel (IBT) (Grantz, 2013). In this case the residual weight of the SFT is supported by piers based on the seabed of the crossing (Figure 1.7). An advantage of this solution is that piers can be located with bigger spans than pontoon but a limit is the constructability of the piers in deep water.

It is thought as the safest solution for a Submerged Floating Tunnel. It is argued that the major drawback of the conventional submerged floating tunnel concept has been that if it were to be flooded accidentally or through sabotage, the costly facility would be completely and catastrophically destroyed. If the tethers would go slack (or sink the pontoons) would cause a complete collapse of the entire structure (Grantz, 2013).

Thereby, the way to provide stability for a flooded tunnel might be to build a submerged floating tunnel supported on piers which can be catalogued as an immersed tunnel supported on piers. Thus, if the piers and footings were designed to take the load and the flooded tunnel was designed to span between the piers, the result would be a stable structure. Depending on local environmental conditions, this could be a feasible alternative for the unsinkable SFT for water depths of up to say 300m (Grantz, 2013)

With this design however, if a single module were breached by a fire or explosion and the tunnel were flooded, the remaining tunnel structure would stand, could be repaired, and put back into service.

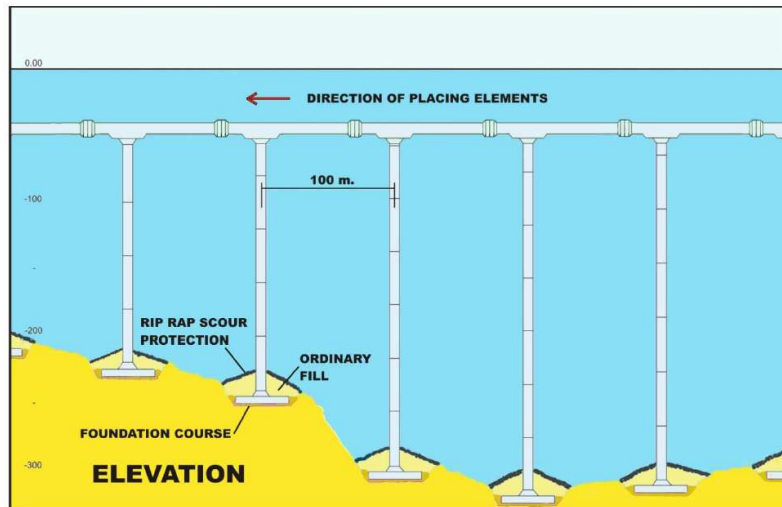

Figure 1.7 SFT supported on piers (Grantz, 2013)

#### 1.2.5. SFT with combined system (anchorage and pontoons)

This solution is becoming more common in the field of SFT. It consists in the combination of a Submerged Floating Tunnel with anchorage system at some place along the tunnel and pontoons in the remaining length. The location of the pontoons and anchorage usually depends of the natural conditions of the crossing especially the depth as wells as the shipping requirements on the surface.

It is usually propose SFT with pontoons in the part where the depth is large and anchorage where is not. Furthermore, if the is required a big navigation channel between the pontoons, the change of anchorage system could be adopted as solution.

The design of this type of Submerged Floating Tunnel has grater complexity than one of the structure working with a single residual buoyancy force. As the other cases, the anchors and pontoons have to be designed for keeping the SFT in its position. It is clearly that a change of regime of the buoyancy resultant will be required. When is necessary keep the cross section along the tunnel a normal solution is to keep positive residual buoyancy about 5-10 %, then where it is possible the pipe elements have to be fixed to the foundation at the sea bed using vertical cables, while in the portion destined to pontoons there is the possibility to use concrete pontoons (with ballast) rigidly connected to the SFT.

Using steel pipes with an arc geometry means that horizontal forces will be taken as tensile/compression axial forces. Moreover, in order improve the global buckling capacity of the arc, has been chose two main steel pipes and connect them with cross pipes; this create a Vierendeel arch truss with an high global stiffness (Opgard, 2013). This configuration can be appreciated in the Figure 1.8.

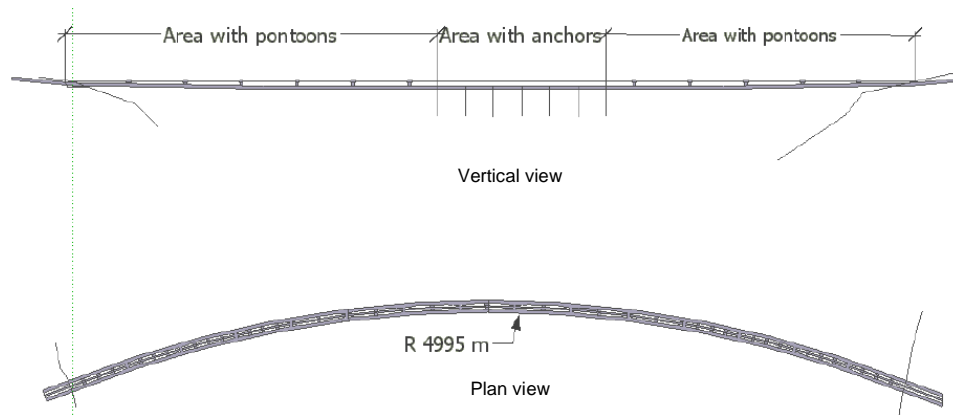

Figure 1.8 SFT with combined system (Multiconsult AS, Norway)

### 1.2.6. Combination of SFT with others structures

In recently years has changed the conventional idea of Submerged Floating Tunnels. The original idea passed from a single floating structure to a functional structure adaptable to the conventional structures well known nowadays. It is no mandatory proposed a Submerged Floating Tunnel as solution for a water crossing. Otherwise, a reality is that a SFT can be combined with common waterways crossing as bridges, immersed tunnels, and subsea tunnels until more complex structure as floating bridges. The last mentioned is another emerged technology with many applications around the world and really related to the SFT principle.

#### 1.2.6.1 SFT with immersed tunnels

It is a common alternative that has to be considered during a SFT proposal. Any conventional Submerged Floating Tunnel has to be connected to the shore and doing by an immersed tunnel is seems to be the easiest choice for realized it. Furthermore, for cases when the SFT is supported on piers, the combination would be ad hoc for both cases. In the case of a strait crossing, only the deeper section would need to be supported on piers whereas all the rest of the tunnel could be constructed as a standard immersed tunnel.

Moreover, the cross section would be virtually the same. So for the construction point of view would represents easiness for the production of the elements. Thus, the shore connection can be realized with some technique used for immersed tunnels as cut and cover or well some bored tunnel.

#### 1.2.6.2. SFT with bridges

Although there are no many proposals around the world for this typology of strait crossing, from the point of view of the author it represents a solution with some advantage than others. It can be employed in crossings where the length of SFT is really large and the bridge could reduce the length of the SFT. It is preferable from the point of view of the users, drive in open motorways like bridges than close roadways like tunnels. A fact is that a bridge has a limit for constructability which depends on the depth of the water. However, in projects as The Hangzhou Bay Bridge, 36km (Figure 1.9a) or Qingdao Bay Bridge, 41.5 km (Figure 1.9b), in China, new offshore construction technology was employed, and piers around 80 m depth were executed. In addition, the bridge as rigid structure could give more stability to the SFT in the horizontal plane.

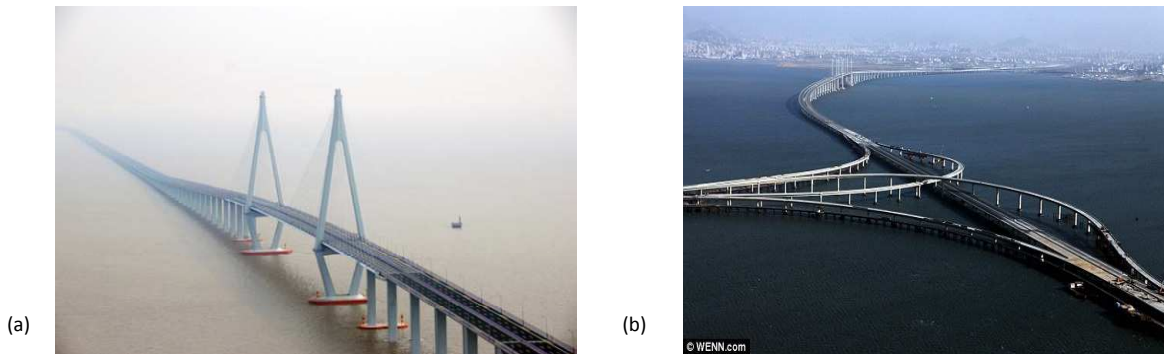

Figure 1.9 (a) Hangzhou Bay Bridge, China; (b) Qingdao Bay Bridge, China (Rengui and Fanchao)

On the other hand, this solution has some disadvantages. It is difficult to connect the road deck level of the bridge with the one of the SFT, thereby special structures would be required for the linking as it is shown in Figure 1.10b (study in the section 1.3.5). Moreover, the piers of the bridge could represent an obstacle for the shipping in the zone, thus there might not be enough clearance for the navigation requirements and sometimes structures with large spans are needed as cable-stayed bridges (Figure 1.9a).

Moreover, from the environmental point of view, placing a bridge in the water crossing could represent a visual pollution for the landscape. Thus, the design step must be realized with an adequate aesthetics.

### 1.2.6.3. SFT with floating bridges

It is another innovative solution that has arrived in recent years. It consists of combining a floating bridge with a SFT. This solution is usually proposed in deep water where no other conventional structure could be considered. The alternative combination has as its aim that the SFT as part of the crossing will allow free ship passage, and the floating bridge will contribute to reduce total construction and maintenance cost of the fixed crossing (Skorpa, 2010)

As in the same case as a normal bridge, this solution has the difficulty of connecting the road deck of the SFT with the floating bridge. The simplest way to construct the link seems to be a big floating pontoon, anchored to the sea bed by tension tethers, with a spiral roadway inside the pontoon to link the roadway on the floating bridge to the roadway in the SFT (Figure 1.10b). With the navigation channel located in the middle, the SFT has to span between two pontoons, otherwise the SFT might span between the pontoon and the shore. This solution is studied in the section 1.3.5 of this work.

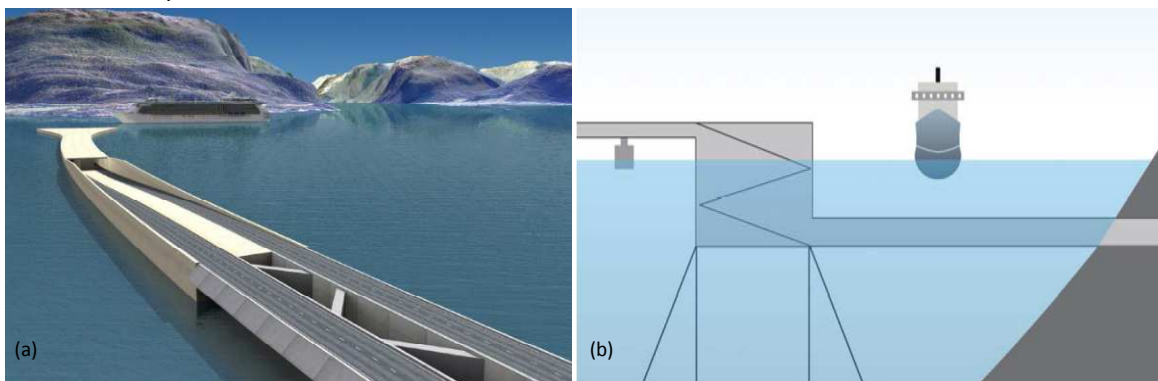

Figure 1.10 (a) Combination of floating bridge and submerged floating tunnel (Norwegian Public Roads Administration); (b) Solution of link between SFT and Floating Bridge (Skorpa, 2010)

### 1.3. Structural elements for Submerged Floating Tunnels

#### 1.3.1. Cross sections typology

The cross section configuration of a Submerged Floating Tunnel can be considered as the main issue of the design. It must have a geometry that optimizes the functions inside and outside. Internally, it must provide the enough space for housing the lanes of service whatever is the use as wells as the different facilities requires for the operation. Ventilation, drainage, emergency exits, lighting and so on, are needed for the operation of the SFT. On the other hand, externally is important provide an adequate shape in order to minimize the impact of the hydrodynamic actions. Any circular, elliptical or rounded shape is adequate for this task.

The most common cross section shape proposed for the different Submerged Floating Tunnel solutions in the world can follow these types:

- circular
- elliptical
- polygonal
- rectangular

The original idea of a Submerged Floating Tunnel considered a tube or circular cross section as the solution for the crossing. This configuration has been proposed for many cases since SFT concept arrived until nowadays. Some proposals are the Messina Strait (Figure 1.11a; Scolari et al, 1989), the Høgsfjord (Figure 1.11b; Skorpa and Østlid, 2001) and Sulafjord (Figure 1.11c; Jakobsen et al., 2009), these last two in Norway. A circular cross-section features a very rational structural behavior with respect to the hydrostatic pressure (Brancaleoni et al., 1989; Grantz, 1997), as this induces only compressive stresses and no bending in the cross section plane. Since generally the outer ring shell of a circular SFT is at least partially made up of concrete, this is a great advantage, since no longitudinal cracks are produced by the hydrostatic pressure, thus not compromising the tunnel waterproofing. Moreover a circular cross-section features a good response with respect to hydro-elastic stability issues, since, thanks to its polar symmetry, it should not be subjected to flutter or torsional divergence phenomena (Solari, 2010)



Figure 1.11 SFT with circular cross section. (a) Messina Strait crossing (Italy) proposed by ATI-SSST (Scolari et al., 1989); (b) Høgsfjord crossing (Norway) proposed by Aker Norwegian contractors (Skorpa and Østlid, 2001); (c) Sulafjord crossing (Norway) (Jakobsen et al., 2009)

In addition, it can be consider a SFT configuration which involves two tubes or more. This solution can destine the traffic of each tube in different directions or use, as motorway or railway. Furthermore, one tube can be adapted for housing the facilities or ballast in case of being required. The configuration can involve an additional substructure in order to enclosed all the tubes and act as streamlined shell (Figure 1.12a).



Moreover, in the case of two separate tubes more horizontal stiffness can be earned. In the safety point of view, when an incident is present on one of the tubes, the users can change to the other with no relevant problems. The Figure 1.12 shows two different proposals in the world for SFT with composed circular cross section. The Figure 1.12a is the first SFT proposal for the Messina strait developed by Alan Grant in 1969. The Figure 1.12b is one of the newest SFT proposal for crossing the Sognefjord in Norway.

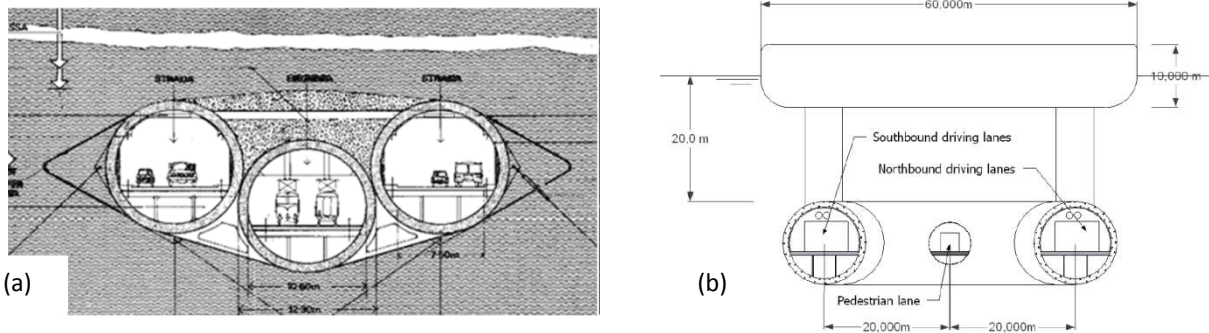

Figure 1.12 SFT proposals with various tubes. (a) Messina Strait proposal (Alan Grant, 1969); (b) Sognefjord crossing proposal (Multiconsult AS, Norway, 2012)

On the other hand, in cases when the water conditions are stronger elliptical and polygonal cross sections can be employed. The elongation of the cross section in the horizontal direction helps to decrease the impact of the hydrodynamic actions on the tube. In addition, these shapes provide larger values of stiffness and strength in the horizontal bending plan which ensures the good hydrodynamic behavior.

In the point of view of distribution it is easier accommodates the traffic and facilities requirements in a polygonal than elliptical cross section. In order to provide the requirement space, sometimes the elliptical section might be enlarged overly. Furthermore, the production process of the elements is easier for polygonal cross sections than elliptical ones. In the Figure 1.13 can be appreciated some proposals of elliptical and polygonal SFT cross sections around the world.

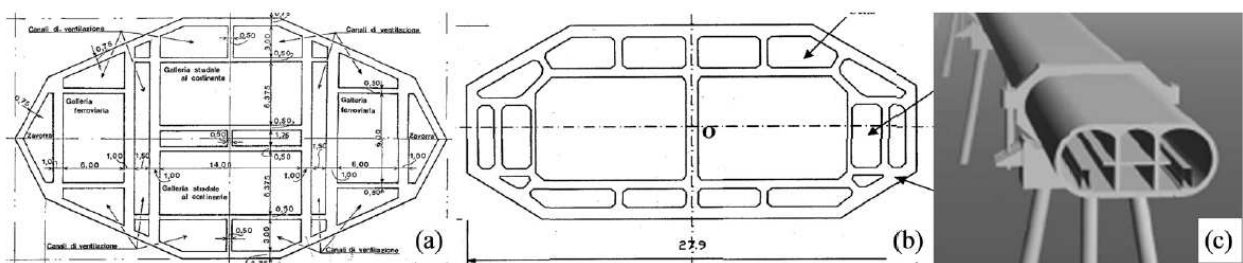

Figure 1.13 (a) Messina Strait crossing, Italy (Ponte di Archimede S.p.A., 1984); (b) Jintang Strait crossing, People Republic of China (Faggiano, et al 2001a); (c) Washington Lake crossing, USA (Felch et al, 2001)

Finally, a rectangular cross section can be adopted as SFT cross section. This solution is the most widely used for immersed tunnel technology, however IMT are no subject to hydrodynamic actions. It is an adaptable shape for placing the facilities as well as the traffic requirements. In addition the production procedures are faster than the others shapes. In IMT technology the improvement of the production process has lead to planning longer projects and shorter period.



Clearly, the hydrodynamic behavior of a completely rectangular shape is not suitable for SFT under severe conditions. The water flow passing through a rectangular SFT would generate turbulence, thus increase the regime of dynamic pressures induced on the structure. In order to improve the hydrodynamic behavior, one solution could be a rectangular cross section with rounded edges. This solution is recommended when the magnitude of currents and waves are not large. Another suitable solution in extreme natural conditions is the employ of hydrodynamic lateral keel which can be fabricated of steel shells and trusses. This would improve the fluid dynamic behavior of the SFT, preserving the advantage of the rectangular cross section. The Figure 1.14a a rectangular cross section with rounded edges while the 1.14b and 1.14c illustrate the solution with lateral keels. The latest was employed as solution for Tsing Ma Bridge in Honk Kong.

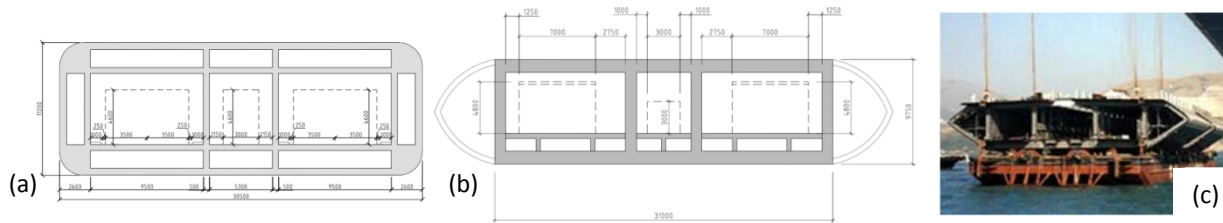

Figure 1.14 (a) Sognefjord crossing, Norway (Sweco Norge AS, 2012); (b) Sognefjord crossing, Norway (Cowi AS, Aas-Jakobsen AS, Johs Holt AS, NGI and Skanska AS, 2012); (c) Tsing Ma Bridge element, Hong kong.

### 1.3.2. Materials

The selection of the materials to be used to build a Submerged Floating Tunnel must be made accordingly to the structural and functional performances which are intended to be ensured, but it has also to be a compromise among several factors such as the resistance to the marine environment, fabrication, assembly and maintenance issues, time needed for the supply, material and constructional cost and so on (FEHRL, 1996).

The structural solution can be optimized, considering the structural effectiveness, the constructability and the economical point of views: it is possible to conceive a SFT featuring a composite structure involving several materials. In this way each material has a particular function which exalts the material advantages and neutralizes its defects (Faggiano et al. 2001b)

The most recommended materials for using on Submerged Floating Tunnels are:

#### a. Steel

It is a commonly employed in offshore structures. Its performance is largely experienced, also concerning the long term behavior. In order to improve its performances in maritime applications new types of steel have been introduced, featuring a lower content of carbon and resistant to corrosion, whose main problem seems to be only the difficulty to produce them in large scale (Ramasco et al., 1991). New production technologies led to the development of a new type of steel, named Fatigue Crack Arrester (FCA), whose microstructure ensures a better resistance to the propagation of fatigue cracks, especially in the welded joints, assuring also a strength slightly larger and a weldability equivalent to those of ordinary steel (Arimochi et al., 2003). The Table 1.3 shows the general advantage and disadvantage of steel in marine conditions.

<b>Advantages</b>	<b>Disadvantages</b>
Good mechanical properties	Low resistance to corrosion
Good resistance to fatigue	Low performance of welded connections with respect to fatigue due to the cyclic loads imposed by environmental actions
Good resistance to abrasion	
Good workability	
Good weldability	
Large strength-to-weight ratio	Low resistance to fire

*Table 1.3 Advantage and disadvantage of the steel for SFT use*

b. Concrete (reinforcement and/or prestressed)

Concrete is also widely used in maritime applications and its use is greatly recommended when a large structural weight is required in order to stabilize the structure. This is particularly true for SFTs, where concrete can be used to contribute to the structural strength and stiffness and, at the same time, to provide the weight needed to counteract the tunnel buoyancy (Martire, 2010). Prestressed concrete is largely employed in offshore structures, as it leads to better mechanical performances and, above all, to a larger degree of waterproofing. The Table 1.4 shows the main aspects for the concrete use in SFT.

<b>Advantages</b>	<b>Disadvantages</b>
good resistance to the corrosion in marine environment	Negligible resistance to tensile stresses
Good resistance to abrasion	
Good resistance to fire and high temperatures	
Possibility to be cast to realize complex shapes	
Low cost	

*Table 1.4 Advantage and disadvantage of the concrete for SFT use*

c. Aluminium alloys

Their main application in offshore structures is in the emerged part of the offshore platforms. The Table 1.5 summarized the mechanical properties for its use in marine environment.

<b>Advantages</b>	<b>Disadvantages</b>
Wide range of strength, comparable to the one of steel grades	Poor resistance to fire
Good workability	Stiffness lower than steel
High resistance to marine corrosion	Specific weight relatively low, it being equal to 1/3 of the one of steel
High resistance to resilience	High cost

*Table 1.5 Advantage and disadvantage of the aluminium alloys for SFT use*

d. Rubber foam

It is a porous rubber made up of expanded polyurethane used in the Naval Engineering to increase the buoyancy of vessels. This material has been considered for applications in SFTs to create an external layer protecting the inner structure from corrosion and external impacts and increasing the tunnel buoyancy. In fact this material is extremely light and is also able to dissipate the energy transmitted by external impacts (Grantz, 2003).

### 1.3.3. Support system

In the section 1.2 were studied all the typologies of Submerged Floating Tunnels. It was clear that except the self supported tube, all the rest require a support system along the structure. The system can be fixed at the seabed by foundation systems or on the surface by pontoons. In some cases combination of both system are proposed. The selection of the configuration is related with the preliminary design of the SFT, principally the environmental conditions.

#### 1.3.3.1. Pontoons

Pontoons are employed when the residual buoyancy has a negative value, it means that itself weight of the structure is larger than the buoyancy of it. These elements are fixed on the surface of the water crossing. They act as supporters for the SFT in order to keep the structure on its position in both directions horizontal and vertical.

Usually their design depends of the SFT cross section and the shipping requirement. The first issue is in order to provide the enough buoyancy for support itself weight as well as the SFTs. Furthermore, the pontoons must be placed for providing enough clearance for the shipping requirements. In some cases the space between pontoons is not enough for the vessels in the region, thus a navigation channel must be provide (Figure 1.15).



*Figure 1.15 Scheme of SFT with pontoons on surface (NPRA)*

Pontoons are only able to provide vertical support and lead to more flexible system; they can be applied in less severe environmental conditions. Pontoons have the advantage of being independent of the water depth, but they have to cope with ships, waves, tides and ice. Pontoons might be fabricated of steel or concrete, having several compartments of ensure buoyancy in the event of a ship collision. The fixing of the pontoons to the SFT should be made through a “weak link” joint, which would save the SFT in the event of a ship collision, i.e. the pontoons would be shared off and the tunnel tube would remain intact (FEHRL, 1996).

Thereby, ships would have tremendous impact energy in case of a collision. To isolate the tunnel from impact overload an impact 'fuse' mechanism could be introduced between the pontoon and tunnel (Figure 1.16). A weak link will also beneficial with respect to damages to the ship. The ship impact mechanism limits the forces that can be transferred to the concrete tubes by ensuring a shear failure in the pontoon shaft. In the ship impact mechanism the shear forces are separated from axial forces and moment to be able to accurately predict the failure load (Fjeld et al., 2013).

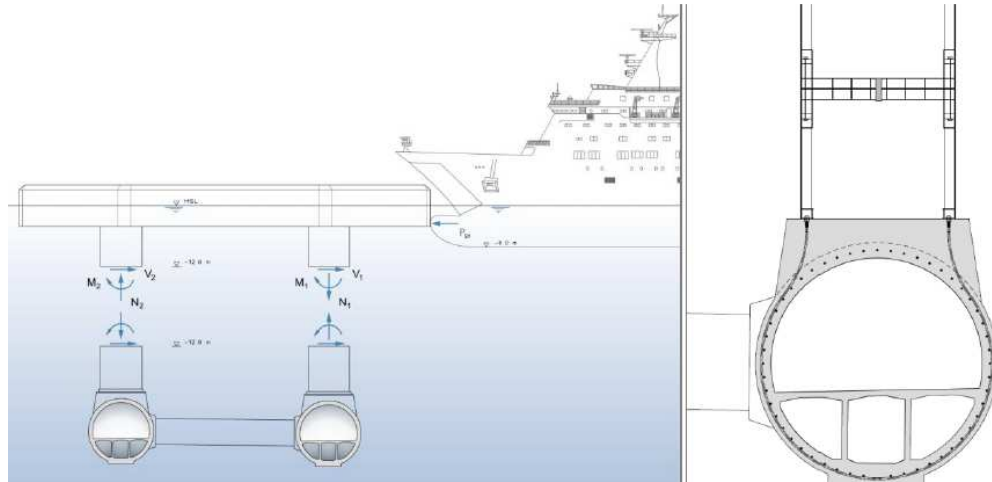

Figure 1.16 Ship impact mechanism ( Dr.techn. Olav Olsen, 2012)

Some advices for the design of Submerged Floating Tunnels in case of utilize pontoons could be:

- The tunnel can be designed to tolerate loss of one pontoon without losing its structural integrity or suffering other structural damage. By tuning the water ballast it is even possible to have an operable bridge in the period until a new pontoon is in place.
- The pontoons can be designed to have damage in one or more compartment without instability problem. With an adequate residual stability after damage and flooding the buoyancy must allow the normal transit on the tube.
- It is highly recommended introduce a “weak link” in the shafts to prevent overstressing of the tunnel structure.
- For absorbing the impact energy, a sliding friction fender can be suggested.

### 1.3.3.2. Foundations

In the case when the buoyancy of the SFT is greater than itself weight, foundation system must be required. The purpose of the foundation is support the maximum residual buoyancy force of the structure in order to keep it on position. The elements are placed on the seabed, thus are directly dependent of its condition. The criteria for the selection of the foundation principally depend of:

- Seabed condition. Principally the type of ground, seismicity and fouls.
- Depth of the water crossing. For the constructability point of view.
- Strength to support. The feasibility of dimension according the type, huge dimensions can be minimized with another type of foundation.
- Technology available. Important to consider the technology available in the region.
- Cost. Important for the project feasibility.

In general any type of structure that could help to hold the Submerged Floating Tunnel on position can be considered suitable for employing while stability is guaranteed. Furthermore, many of the new technology develop in offshore structures could be analyzed if it adequate for the particular case.

The typology of foundation employed for Submerged Floating Tunnel can be appreciated in the chart 1.17

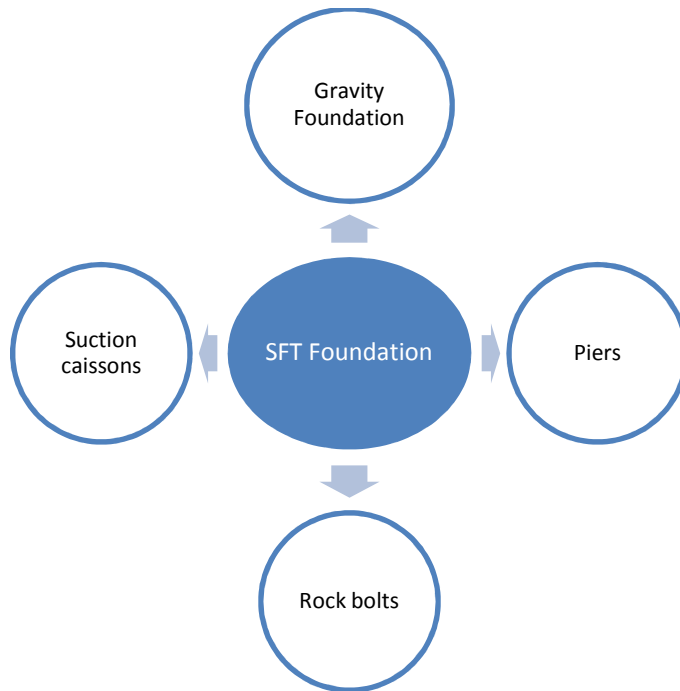

Figure 1.17 Typology of foundation for SFT use

#### 1.3.3.2.1. Gravity foundation

Gravity foundations consist in massive blocks, designed to have enough weight in order to counterbalance the upward residual buoyancy of the SFT. Their main problems are related to the need of a superficial soil layer with good mechanical properties and to their low horizontal bearing capacity; moreover, in case of severe seismic events, the combination of the vertical upward and horizontal dynamic forces might lead to their permanent horizontal displacements, modifying the geometrical configuration of the anchoring system (Martire, 2010).

Generally the elements consist in concrete boxes that are precast in a dry yard, then because their own buoyancy capacity is transported until their correspondence place in the project. Once is in the correct location are fill them with concrete to produce the sinking until the seabed, where finally they act as gravity foundations. In the Figure 1.18 is schematized this sequence.

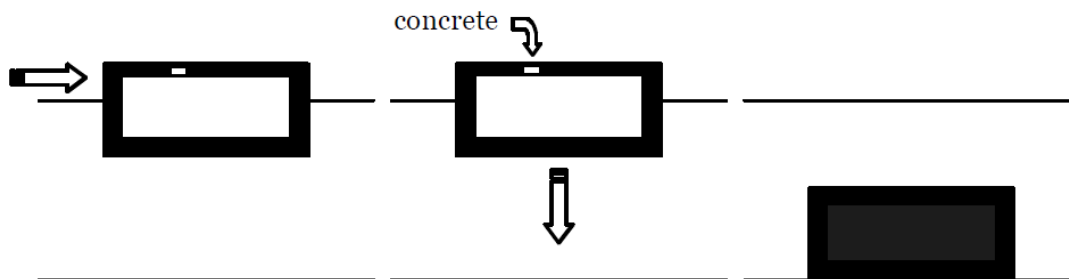

Figure 1.18 Sequence of transport and erection of foundation (Mazzolani et al, 2007)

#### 1.3.3.2.2. Piers

The piers can be employed when the permanent weight of the SFT is greater than the buoyancy. In the point of view of the author is a safer solution than employ pontoons due to the tube would not be exposing to the

shipping traffic. However, this solution is limited by the depth of the water crossing. At some point depth make piers impractical because of column length and stability during and after construction.

In the same way than piers are used in other marine structures their fabrication could be realized with concrete or steel. Moreover, as solution for supporting can be adopted one single pier or a group. The solution of a single pier as it is shown in the Figure 1.7 is the general solution for SFT supported on piers. This type of solution is feasible for heights in the order of 250-300m, and concrete is the most practical solution the material.

For the solution Walter Grantz proposed a construction method from the surface due to divers becomes inefficient at depth of more than 50m. Firstly, is prepared the ground to receive each pier footing. Unsuitable soil must be dredged and removed using a clamshell excavator and barges (Figure 1.19). Such a process would be very slow because of the time it would taken for each bucket load to go down 300 meters, dig, and return to dump into the barge. If environmental regulations would allow, it would be more efficient to simply move the spoil to piles outside of the excavation. This could be done with a regular bucket dredge or it could be done with a special catamaran barge equipped with a 100m long rail and traveler system controlled from a bridge. The bucket could be equipped with digital sonar so that its precise location and elevation could be monitored as the excavation proceeded. The great depth of excavation would likely cause lateral drift of the barge, cables, or bucket but if the catamaran were equipped with steerable thrusters on each corner, it could automatically station-keep based on the desired 100m track of the bucket (Grantz, 2013).

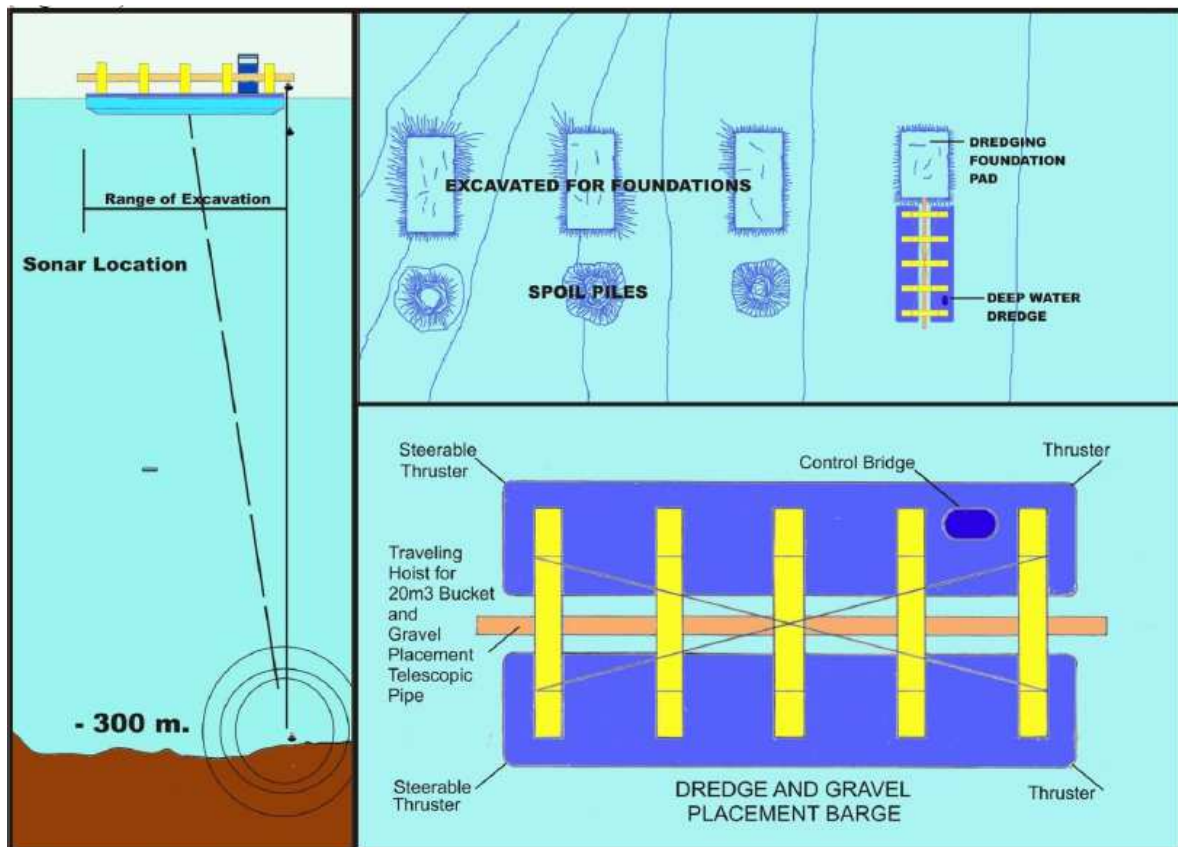

Figure 1.19 Barge proposed for excavation of the gravel foundation pads (Grantz, 2013)

Then a base for the pier footings can be installed, perhaps using the same catamaran with telescopic pipes to deposit measured quantities of the gravel foundation course. The surface may then be graded using something



similar to what was used during the Bosphorus Rail Tunnel Project. It was a remotely controlled underwater grader. The latter provided a smoothly graded surface. Its operation was monitored with video cameras and grader blade position in three axes was transmitted in real time to the surface using acoustical measurement. (Figure 1.20)

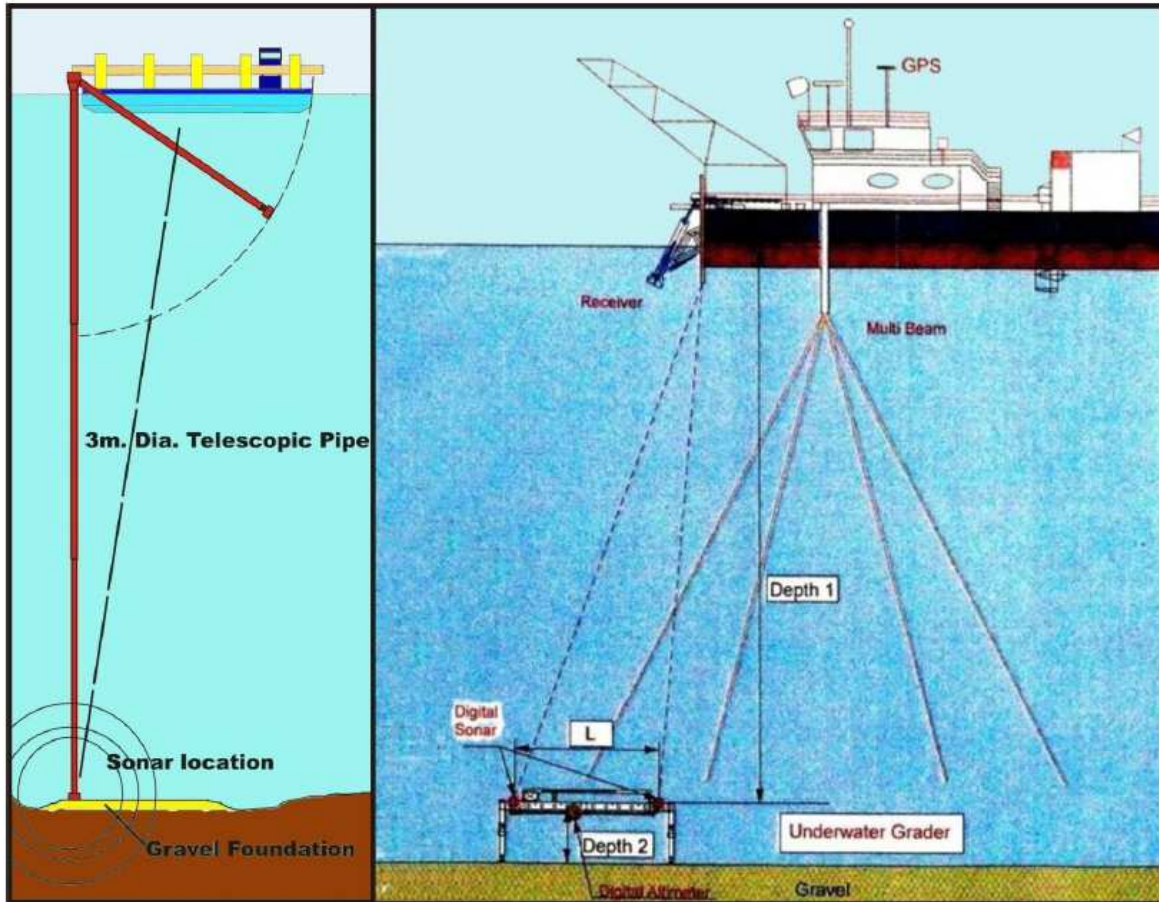

Figure 1.20 Foundation material placed by telescopic pipe and graded with remote underwater grader (Grantz, 2013)

The Plan and elevation in Figure 1.21 show a possible equipment setup for progressively constructing the piers in place. The arrangement is designed for the progressive assembly and lowering of the footing and pier assemblies onto the prepared gravel foundation. Once this was done and the positioning of each pier was verified, they could be backfilled and protected with stone riprap (Figure 1.7).

The pier construction would first involve a barge carrying the concrete footing (previously cast-in-place on the barge) into position where it can be connected to the four lowering pulley blocks (or “falls”) and lifted off the barge with the falls. The barge is then towed away. A match-cast modular section of the pier shaft can then be added and post-tensioned to the footing. Following this operation the combined footing and first shaft section is lowered to a working elevation so that a second shaft module can be post-tensioned to the first. This operation is repeated to build the shaft to the desired height. As this is done, the as-built height of the footing and pier shaft will be carefully measured. The weight during construction can be controlled by building the shaft modules with watertight air filled compartments to make them buoyant. This will also aid in the stability of the shaft as it hangs from the falls (Grantz, 2013)

Nearing the completion of a pier shaft/footing it will be lowered onto the gravel foundation for a final elevation check before custom casting and attaching the last shaft section that will support the tunnel. The top elevation and station of each pier will be carefully controlled to a small tolerance in the order of a few centimeters. In this way the tunnel alignment will be maintained accurately. Small variations in tunnel alignment in this order are common in any immersed tunnel (Grantz, 2013)

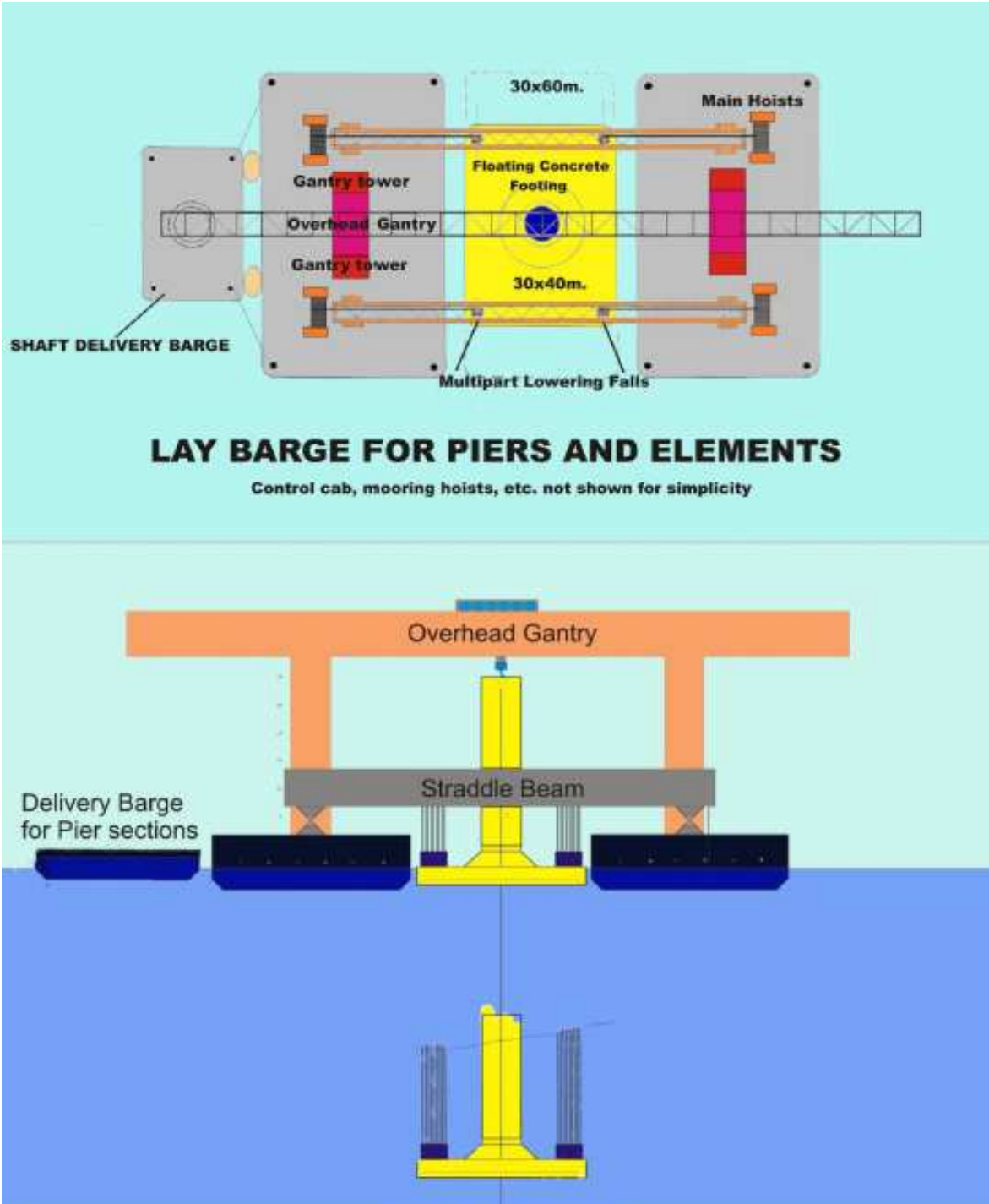

Figure 1.21 Plan and Elevation of equipment arrangement for building piers in situ (Grantz, 2013)



On the other hand, in some cases since the point of view of ease is necessary the employed of group of piles. It consists of several vertical and inclined free spanning piles tied together at a pile-cap, usually made of concrete (Figure 1.22). A piled foundation may in principle be based on friction bearing piles or end bearing piles. For friction bearing piles the capacity is limited by the soil conditions, for piles embedded in rock the capacity will be limited by the structural capacity of the piles. A piled foundation is typically effective for water depths between 5 and 50m (Aas-Jakobsen et al., 2013).

The pile type is chosen based on the design loads, soil conditions and ease of installation. Driven piles are generally preferred, as they are easier to install. Bored piles will be required if the soil is hard and in cases also for large diameter piles due to lack of suitable hammers. Typical diameters are 600 mm and upwards.

For cases when piles are driven to bedrock a pile shoe is added to ease the chiseling. If the bedrock is located too deep, vertical capacity is obtained by friction and the piles are driven sufficiently deep to obtain the required vertical capacity. In the case of friction bearing piles it is good practice to include bearings at the top of the bridge column to allow for later jacking in order to compensate for possible future settlements.

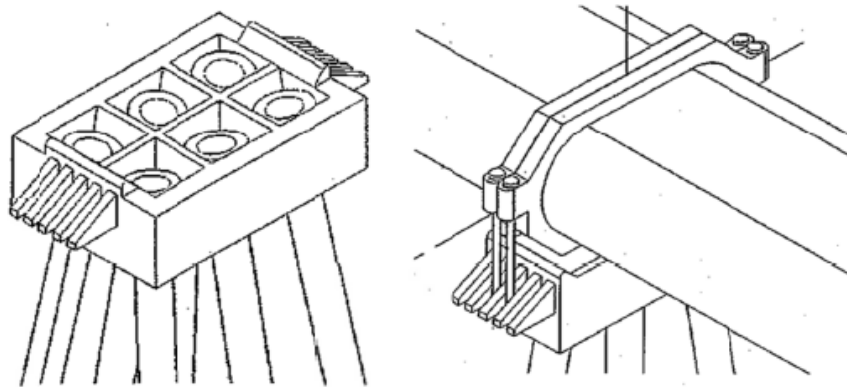

Figure 1.22 Group of piles supporting the SFT (Felch et al., 2001)

#### 1.3.3.2.3. Rock bolts

Rock bolt is an element normally use for stabilizing unstable ground or rock. It transfers load from the unstable exterior to the confined (and much stronger) interior of the rock mass. The rock bolt installation follows these main steps:

- Drilling and cleaning the hole in the location of the project.
- Putting the anchor bar which has installed expansion shell into the bottom of the hole.
- Filling the hole with grout in order to allow transmit the forces to the ground through their compression (Figure 1.23).

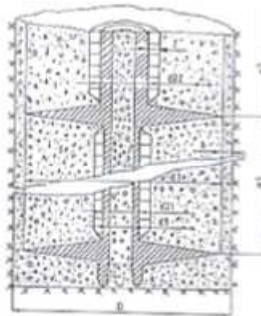

Figure 1.23 Detail of the terminal part of the rock bolt (Odegard, 1994)

Rock bolt reinforcement is simple and quickly to apply, and is relatively inexpensive. Their installation can be fully mechanized. Rock bolts can be adapted for use as foundation of single cable or tether restraining a SFT.

#### 1.3.3.2.4. Suction caissons

Suction caissons (also referred to as suction anchors, suction piles or suction buckets) are a new form of offshore foundation that have a number of advantages over conventional offshore foundations, mainly being quicker to install than piles and being easier to remove during decommissioning. Suction caissons are now used extensively worldwide for anchoring large offshore installations to the seafloor at great depths.

The concept of suction technology was developed for projects where gravity loading is not sufficient for pressing foundation skirts into the ground. The technology was also developed for anchors subject to large tension forces due to waves and stormy weather. The suction caisson technology functions very well in a seabed with soft clays or other low strength sediments. The suction caissons are in many cases easier to install than piles, which must be driven (hammered) into the ground.

The suction anchor penetrates under its weight to some depth and then is forced to the design penetration by pumping water out of the caisson to create an underpressure/suction within the caisson. The difference in pressure results in a downward force on the exposed end of the cylinder, which slowly pushes the anchors in the seafloor and provides the required bearing capacity (Figure 1.24).

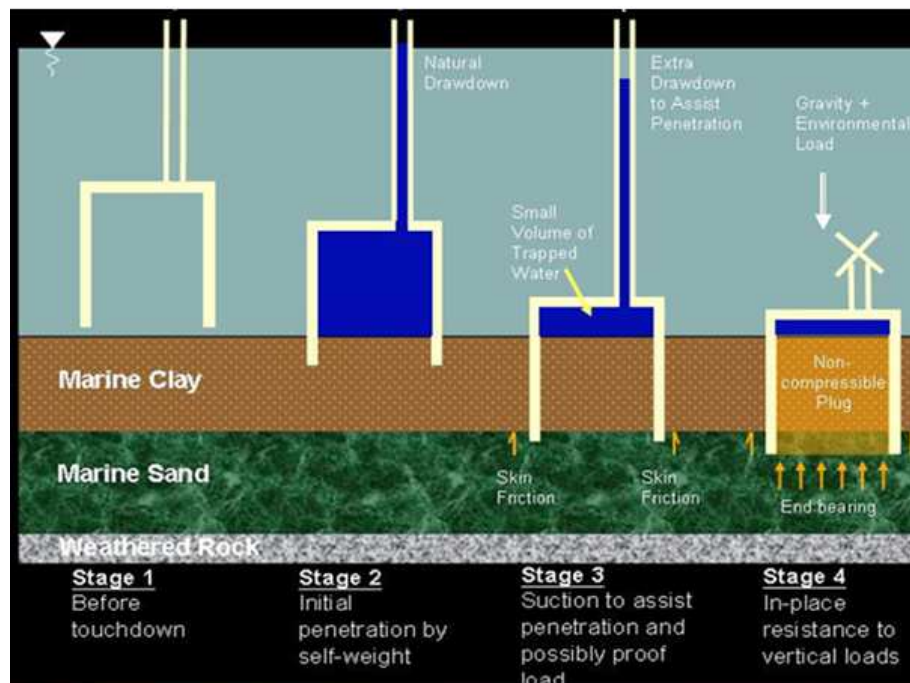

Figure 1.24 Suction caisson installation steps (Arup)

#### 1.3.4. Linking system

In addition to the support system is required elements to link the Submerged Floating Tunnel with the fixing system either foundation or pontoon. The most common linking systems are steel tethers as cables, bars or

tubes. In recent years the improvement of offshore technology has developed the use of Tension Leg Platform as solution for fixing the structure to sea floor.

#### 1.3.4.1. Cable system

The cable system of a SFT is usually conceived as a series of cables groups, disposed in the tunnel cross-section plane and repeated along the tunnel axis with a fixed inter-axis. Therefore the cable system restrains effectively the tunnel only in the transversal directions, and its stiffness is largely influenced by the geometrical arrangement of the cables groups. Several configurations have been proposed and tested, where has been consider different number of cables involve as wells as a varied inclination. A sample of cable configuration is shown in the Figure 1.25 borrowed from the study of Maeda et al., 1994.

Physical predictions suggest that groups made up of two vertical cables configuration is effective only in the vertical direction, thus being suitable only in a calm environment; groups made up of four inclined cables are the most effective ones, as they support the tunnel vertically, horizontally and torsionally. Groups made up of only two sloped cables have been proposed too, but numerical analyses showed that this arrangement leads to high level of stresses in the cables and induces considerable torsional moments in the tunnel when it is subjected to horizontal actions (Martire, 2007).

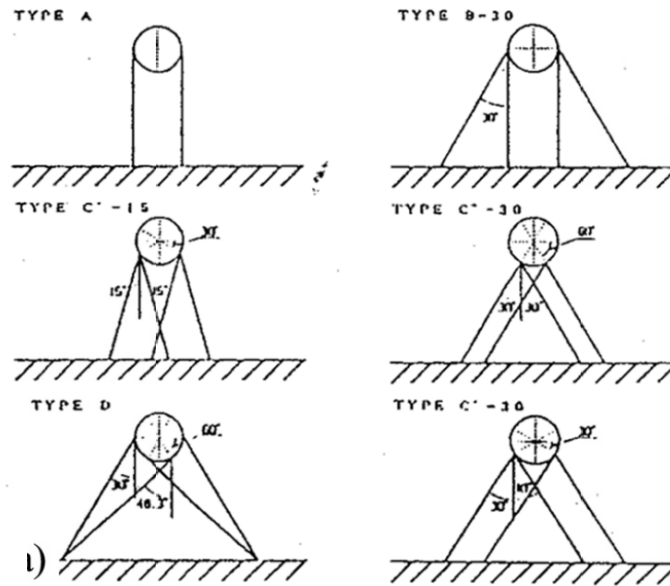

Figure 1.25 Possible configuration of the cable group (Maeda et al., 1994)

In the design of a SFT anchoring system made up of cables, the main choices to be made are related to the geometrical configuration of the cable system, the diameter to be assigned to the cables and the restraint condition to be provided at the ends of the cables.

In the structural point of view the cables must be able to resist the tensile force generated by the residual buoyancy of the SFT. Given the permanent residual buoyancy and the cable length, is choose the diameter of the cables which determines its axial tensile strength, stiffness and also other relevant parameters, such as the

ratios between the initial axial force and the cables strength and weight, respectively. These two ratios are important for the performance of each cable, as they define the axial force increment due to live or environmental loads that can be carried by the cable and the importance of non-linear effects in the cable response (Martire, 2010).

#### 1.3.4.2. Tension Leg Platform (TLP)

Tension Leg Platforms are offshore structure whose anchoring system is made of tensioned tubular members, namely the Tension Legs. The tethers of a TLP are vertical and very flexible, thus allowing for large lateral displacements of the platform, which would be probably not allowable for a SFT. Due to these large horizontal oscillations, specific flexible elements are placed at their connections with the platform and the foundations in order to ensure free rotations. In the Figure 1.26 it is show a typical tension leg or tether string use in production platforms.

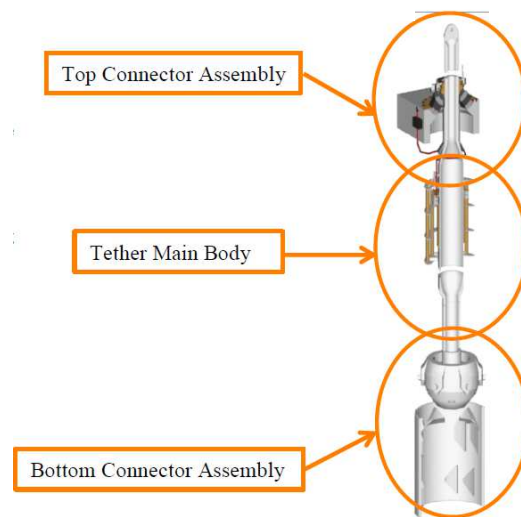

Figure 1.26 Main components of a typical tether string (Monster, 2013)

- Top connector assembly

Though there are two or three different systems, there is only one reliable type of bottom connection. This patented roto-latch system is applied on most of the TLPs currently in operation. The tether part of the bottom connector assembly consists of a forged steel shaft, connected via flexible connection to the bottom connector head (Figure 1.27). The casting forming the head, has lugs on the outside hooking to the receptacle, which is welded onto the foundation. The lugs also guide the head correctly into the receptacle with tendon porch and tendon string top. The tether string main body. The tether bottom connector assembly, with tendon string bottom connector and receptacle, which is connected to the foundation at the seabed. The most common foundations employed in offshore structures are: gravity base structures, partly penetrated gravity based structures, subsea piles.

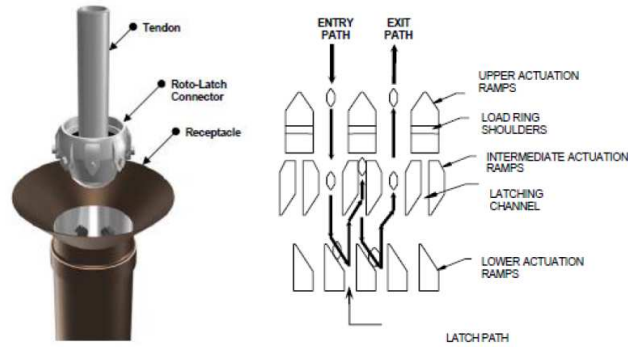

Figure 1.27 Bottom connector assembly (Monster, 2013)

The receptacle is made of a steel forging and is welded to the foundation. Inside the receptacle slots are machined which guide the lugs to latch or unlatch the connector to the foundation. After latching locking pins are to be installed to prevent the connector from unlatching in case of accidental loss of tension.

- Tether String Main Body

The tether structure connecting the platform (via the top connector) to the seabed (via the bottom connector) is called the main body of the tether. The structure normally consists of steel pipe, possibly split in limited lengths and connected with special tether connectors, depending on water depth and the method of installation. For simpler floating structures, steel wires might be used, dependant on requirements and loads. For platforms, the loads are generally too high for steel wire to be applicable. Smaller floating objects might be moored by use of steel wire tethers (Monster, 2013).

When a tether main body segment is constructed out of several elements, these need to be connected. For this purpose a patented connector type is used, based on a circular, threaded pin- and box principle. Connection is achieved by using a special tool, forcing the pin and box together. Using hydraulic pressure the box is expanded, allowing the pin and the threading to slide into place, thus creating the connection (Figure 1.28).



Figure 1.28 Tether String Main Body (Monster, 2013)

- Tether Top Connector Assembly

The top connector should be able to maintain tension, but during the installation process no upward load shall be absorbed in the assembly. Connection to the threaded top of the tether, the length adjustment joint (LAJ) is achieved via threaded wedges or slips, which sit in a seat that is located on the porch structure of the hull. The load bearing ring (the seat) is resting on the porch on a flexible ring, the flex-element.

### 1.3.5. Joints

The joints of a Submerged Floating Tunnel have a fundamental role in the behaviour of the whole structure. They must guarantee the liking between each element as well as the tightness of the tube. Moreover, in the structural point of view, these special elements must lead to the structural behavior which the SFT is designed. If the design allows displacement along the tube a flexible joint can be employed or if not a rigid joint must be adopted.

In addition to the inter module joints, either flexible or rigid, special joints must be located at the ends of the SFT. The shore connection must allow different displacements as longitudinal, vertical, horizontal or torsional, according the design carried on.

#### 1.3.5.1. Inter-module joint

As natural solution for the joint between elements comes the most common solution employed for Immersed Tunnel (IMT). Being both water crossing solution with precast element and ensemble in situ seems to be a good solution to be adopted. A fact is that the most of the IMT use flexible joint between the elements in order to allow the settlement of the ground. With this solution cracks in the concrete can be avoided, thus tightness can be met. However, generally SFT are design as a whole beam and the displacement are allowed only at the ends. For this reason, rigid joint are common adopted as solution.

In general, the inter-module joint must satisfy these principles:

- Tightness
- Durability
- Guarantee performances which do not invalidate the global behaviour of the structure
- Ease at installation process

The table 1.6 has been borrowed from the work made in 2010 by Zhang et al., where is compared the main issues of the rigid and flexible joints.

Items	Rigid joint	Flexible joint
Structural composition	End steel shell, GINA water stop, junction steel plate and reinforced concrete	End steel shell, GINA water stop, OMEGA water stop, shear key, longitudinal displacement limiting device
Deformability	Poor deformability	Absorbing some temperature deformation, consuming some seismic energy for their good deformability
Construction	Long period and great difficulty	Convenient construction
Cost	Cheap	Expensive
Applicable position	End joint	Intermediate joint

*Table 1.6 Comparison of rigid joint and flexible joint. (Zhang et al., 2010)*

##### 1.3.5.1.1. Flexible joints

The use of flexible joints is the most common solution in the practice of immersed tunnels. Usually Gina Gasket and Omega Seal are adopted as solution. The tasks of these flexible seals are:

- Ensure the waterproofing of the tunnel

- Allow for (limited) relative displacements in order to avoid excessive stress increments in the structure due to ground differential settlements or temperature variations
- Guarantee the equilibrium of the structure

The Gina gasket is a solid rubber gasket that is placed as temporary seal at the installation stage. It remains as a flexible compression seal for the permanent stage. The specifications for material characteristics and geometry are usually based on the permanent sealing requirement under expected long-term decompression and relaxation of the gasket. The Gina gasket is placed at the ends of the elements in its entire perimeter fixed by special bolts. In the Figure 1.29 can be appreciate the Gina gasket before the contact between elements.

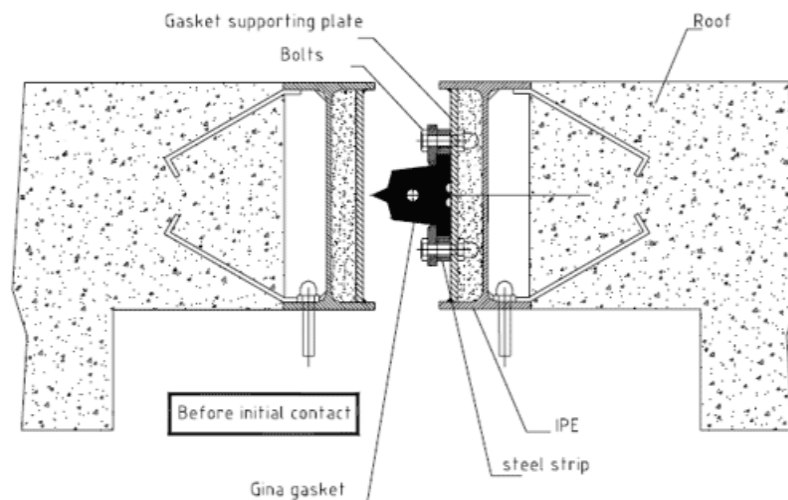

Figure 1.29 Gina Gasket before linking the ends of the elements (Bistoon Baspar Company)

Meanwhile omega seal as it is called because it is curved shape, is a rubber gasket that is installed at the dewatered joint by bolting it to the inside faces of the two tunnel elements. Sometimes this element is considered the main seal of the linking. In the Figure 1.30 is shown the Gina gasket once the ends of two elements are linked as well as the placing of the Omega seal.

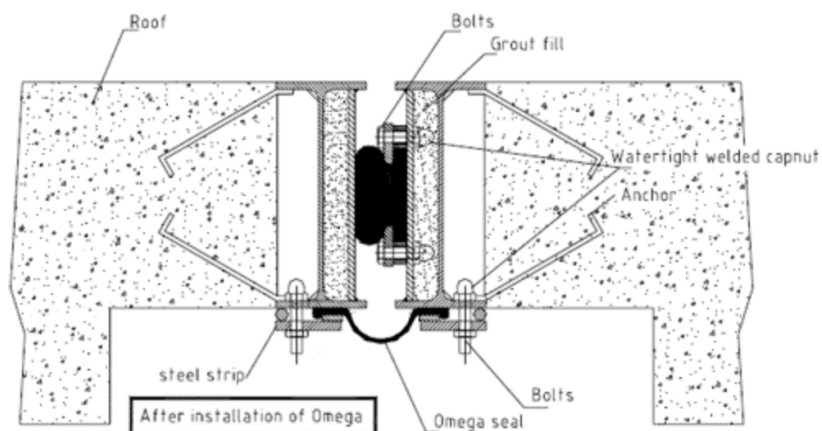

Figure 1.30 Gina gasket after the contact of two element and location of Omega seal (Bistoon Baspar Company)



As it was explained before, the type of joints described above are flexible and accept displacement under the limits established in their design, thus is not recommendable when large displacement are expected. It can be employed for SFT in short length as well as calm natural conditions.

In addition, other complements are employed for provide more stiffness to the elements. Shear keys as well as cables can be used in combination with the Gina and Omega gasket. The shear keys are bearing elements placed in perimeter of the joint between the elements. They have a designed length for transferring the axial force of the tube generated by the longitudinal displacements. The Figure 1.31a shows the location of the shear key in the joint. On the other hand, Cables are arranged to cope with unpredicted tensile displacements larger than the design value due to landslide by the earthquakes or unpredicted large settlement. These cables start to be stressed only for displacements larger than a fixed tolerance. Moreover, pre-stressed cables are provided in order to absorb tensile stresses induced by rotation or axial displacements of the joint. In the Figure 1.31b is shown the cables combined with the Gina and Omega gasket.

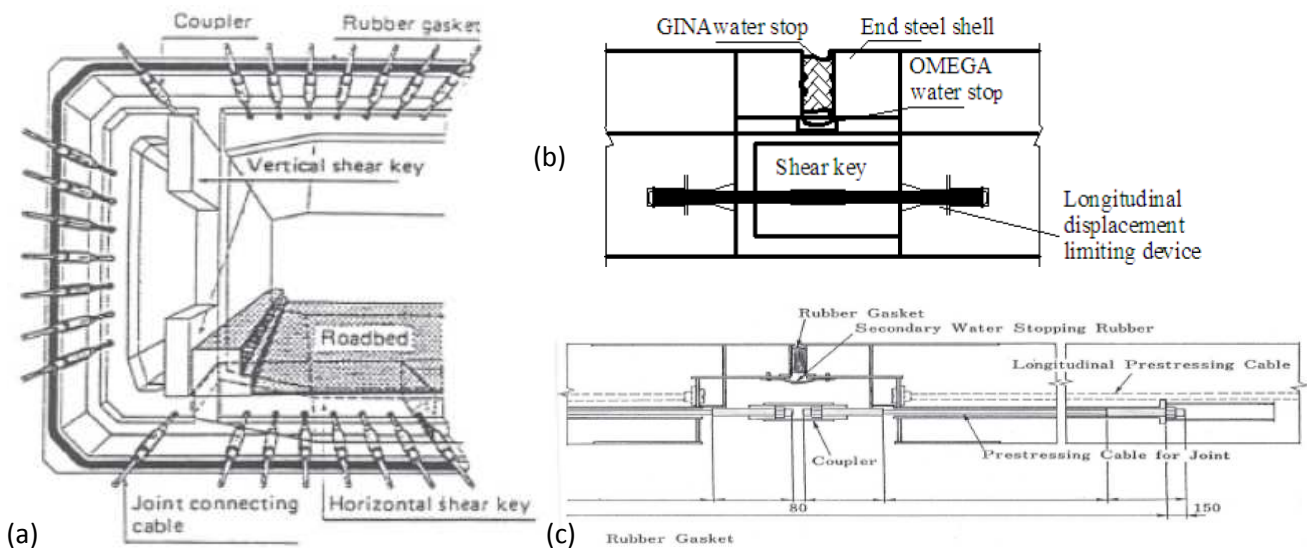

Figure 1.31 (a)Frontal view of shear key in the joint; (b) lateral detail of the shear key in the joint; (c) lateral detail of the pre stressed cable in the joint (Kiyomiya et al., 2003 , 2004)

#### 1.3.5.1.2. Rigid joints

Even though SFTs and Immersed Tunnels are very similar under the point of view of construction and installation, their structural behaviour is quite different. The first ones are generally suspended in the water and can be subjected to significant displacements and rotations in the longitudinal bending planes. On the other hand, IMTs are supported by the seabed soil, thus being subjected to stresses and displacements in the longitudinal planes only because of ground settlements or earthquakes. Therefore the use of a flexible inter-modular joint does not seem to be a suitable solution for SFTs, for which the most rational solution is to have rigid inter-modular joints and terminal joints allowing for axial displacements due to thermal variations and tri-axial rotations (Martire, 2010).

One solution of a rigid joint was proposed by Mazzolani et al. in the design of the Archimedes Bridge Prototype in Qiandao Lake, China. The inter-modular joints for the SFT prototype are essentially bolted connections, designed for being set up and assembled when the modules are already submerged. The joint consists in two



steel ring end plates, each one belonging to one of the adjacent modules. Flanges are mutually connected by means of high strength steel bolts. The bolted flanges are placed at the internal concrete and steel layers. At the external aluminium layer, a rubber ring crushed between the modules guarantees the water tightening of the connection. A sliding rubber ring is placed between steel and aluminium elements, in order to allow relative displacements due to thermal variations. The tensile forces are transmitted by the bolts in tension, whereas the compressive forces are transmitted by the contact between the adjacent steel end plates. The design shear forces are transmitted by friction, whereas the ultimate shear force is assumed to be transmitted by shear in the bolts. Details of the joint is illustrates in the Figure 1.32.

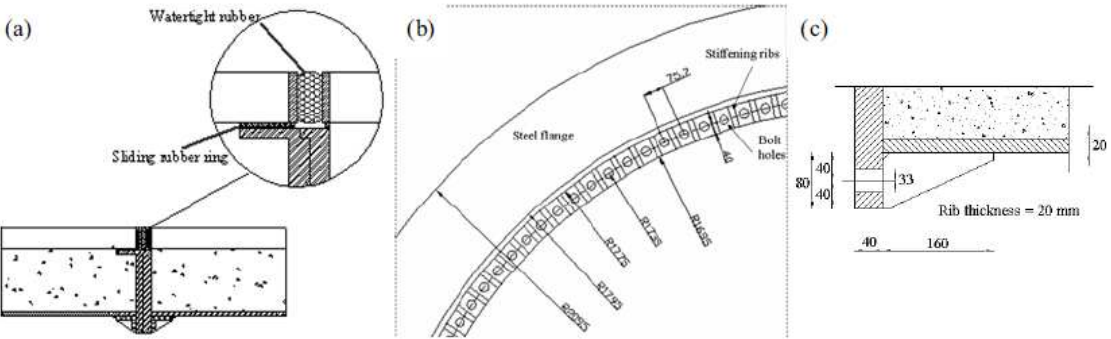

Figure 1.32 Details of inter-module rigid joint for the Archimedes Bridge Prototype (Mazzolani et al, 2010)

An additional solution was proposed by Grantz (2003) also features rigid intermodular-joints (Figure 1.33). In fact the two main steel hulls of this structure are welded full-strength at the joints between the elements. These critical weld areas can be accessed after the Gina gasket, working as a temporary seal during installation of the modules, is compressed and the joint space is dewatered. The roadway space is provided with reusable temporary bulkheads during the placing operation. These temporary bulkheads, in conjunction with the permanent bulkheads of the surrounding compartments, make the ends of each element completely watertight and allow the conventional operation of the Gina connection. Reinforced concrete rings are placed at the module ends, in order to stiffen locally the structure, absorbing the rubber gasket compression force. The Figure 1.33 illustrates this concept.

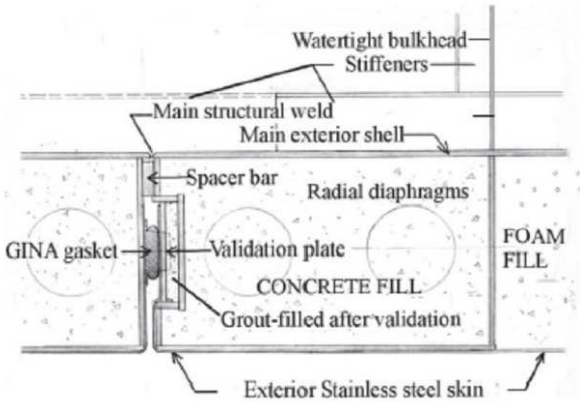

Figure 1.33 Rigid joint proposed by Grantz in 2003.

In extreme cases as SFT with very large lengths and seasonal temperature variation, quite large displacement might be required at the terminal joints of the tunnel. In these cases it would be possible to introduce one or more flexible/semi-rigid joint along the tunnel working as intermediate expansion joint.

In general the suitable solution for the inter-modular joint must meet the safety requirements, including tightness and resistance as main task. The limit of displacement, stiffness as well as the strength induced by the actions which the SFT would be subjected, are issues that have to be consider in the design.

#### 1.3.5.2. Shore joint

The connection of the Submerged Floating Tunnel to the shore requires appropriate interface elements to couple the flexible water tunnel with the much more rigid tunnel bored in the ground. This joint should be able to restrain tube movements, without any unsustainable increase in stresses. Furthermore, the joints must be watertight. Additional care in shore connection is required, especially in seismic areas, due to the risk of submarine landslides (FEHRL, 1996). The transition structure between these two different structural behaviors is known as landfall tunnel. In one of its ends the structure link to the SFT while at the other extreme is linked to the bored tunnel. In other occasions this joint link to special access structures.

A detailed study of the configuration of the shore connection was made for the design of Messina Strait Crossing (Italy) made by the ENI Consortium (Nicolussi and Casola, 1994). In this solution the two joints behave differently:

- The joint between the land bored tunnel and the landfall tunnel releases all the six degrees of freedom between the two adjacent elements. In this way the structural response of the land bored tunnel and the landfall tunnel are decoupled. The Figure 1.34c illustrates the details of the joint.
- The joint between the landfall tunnel and the floating tunnel release all the rotational degrees of freedom and axial movements between the two adjacent elements. Therefore this joint decouples the axial and bending behavior of the floating tunnel and of the landfall tunnel, also reducing the stresses induced by wave, currents, thermal variations and seismic events. In the Figure 1.34b can be appreciate the detail of the joint.

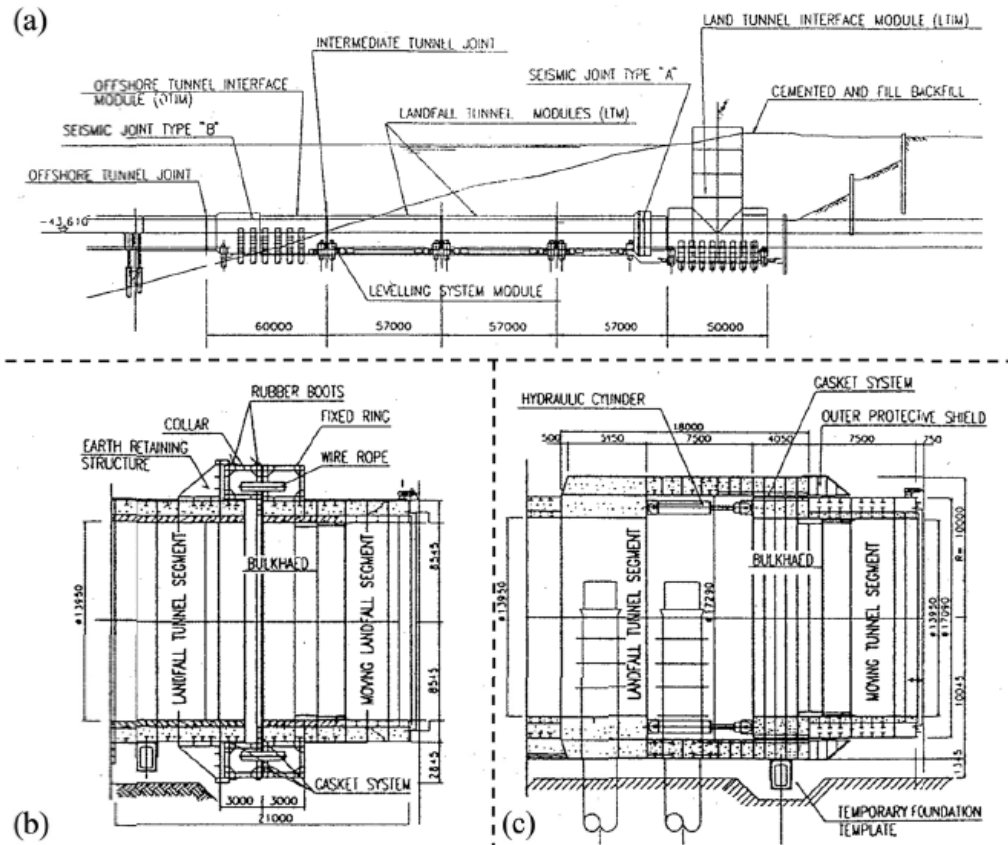

Figure 1.34 (a) Longitudinal view of the shore connection of the Messina Strait crossing proposed by ENI consortium (Nicolussi and Casola, 1994); (b) detail of the joint A; (c) detail of the joint B

Both joints include a gasket system, preventing water leakage inside the tunnel: natural rubber gaskets are squeezed between the surfaces of the joint elements in contact; Teflon sheets are stuck on the steel surface in order to reduce the friction forces (Nicolussi and Casola, 1994). Joint A (Figure 1.34b) is provided with a pre-tensioned system of wire ropes, whose release allows free relative movements in all the six degrees of freedom. Joint B (Figure 1.34c) includes an hydraulic system of 20 jacks distributed along the joint cross-section which absorb axial loads induced by waves, currents and thermal variations in quasi-static conditions. During severe earthquakes, once the established threshold is exceeded, the hydraulic system opens allowing for free axial movements, while accumulators connected to the jacks develop a residual reaction able to maintain the maximum relative movement within allowable design limits. An active back-up system, based on acceleration sensors, controls the proper functionality of the hydraulic system (Nicolussi and Casola, 1994).

On the other hand, a proposed for the shore connection with a SFT was carried out in the prototype of Qiandao Lake, China. Special end joints which are connected to the modules of the prototype at the extremities were designed by Mazzolani et al. in cooperation with ALGA. One of the two end joints must behave like a spherical hinge. With regard to the displacements, the tunnel is axially linked to the shore by means of a mechanical device behaving in elastic range (with high stiffness) in service condition, but it can undergo large plastic deformations when axial forces, during a seismic event, exceed a given limit value, giving rise to hysteretic dissipation of energy. The other end joint must allow both free rotations and axial displacements, in order to give the structure the possibility of free expansion in presence of thermal variations. Furthermore, both end joints must assure the water tightening. The design of the end connections fulfils all the mentioned

requirements. It is based on the concept of separating the waterproof and mechanical functions of the device. The conceptual solution is illustrated in the Figure 1.35a while the constructional solution of this system has is shown in Figure 1.35b

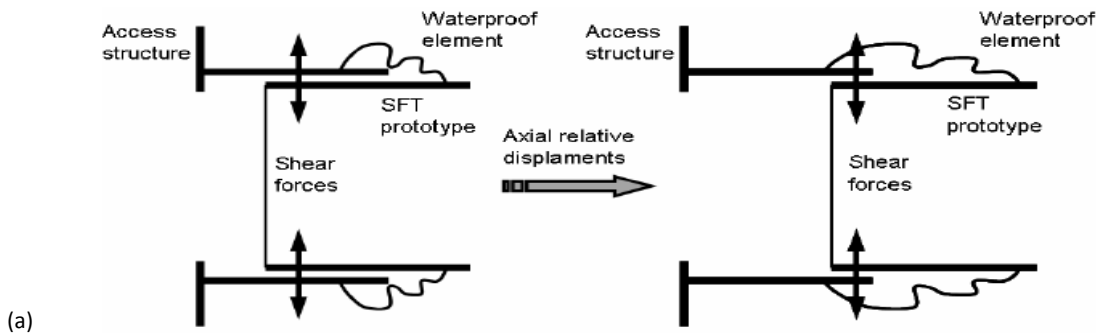

Figure 1.35 (a) Conceptual solution of the shore connection for the AB prototype, (Mazzolani et al, 2007; ALGA)

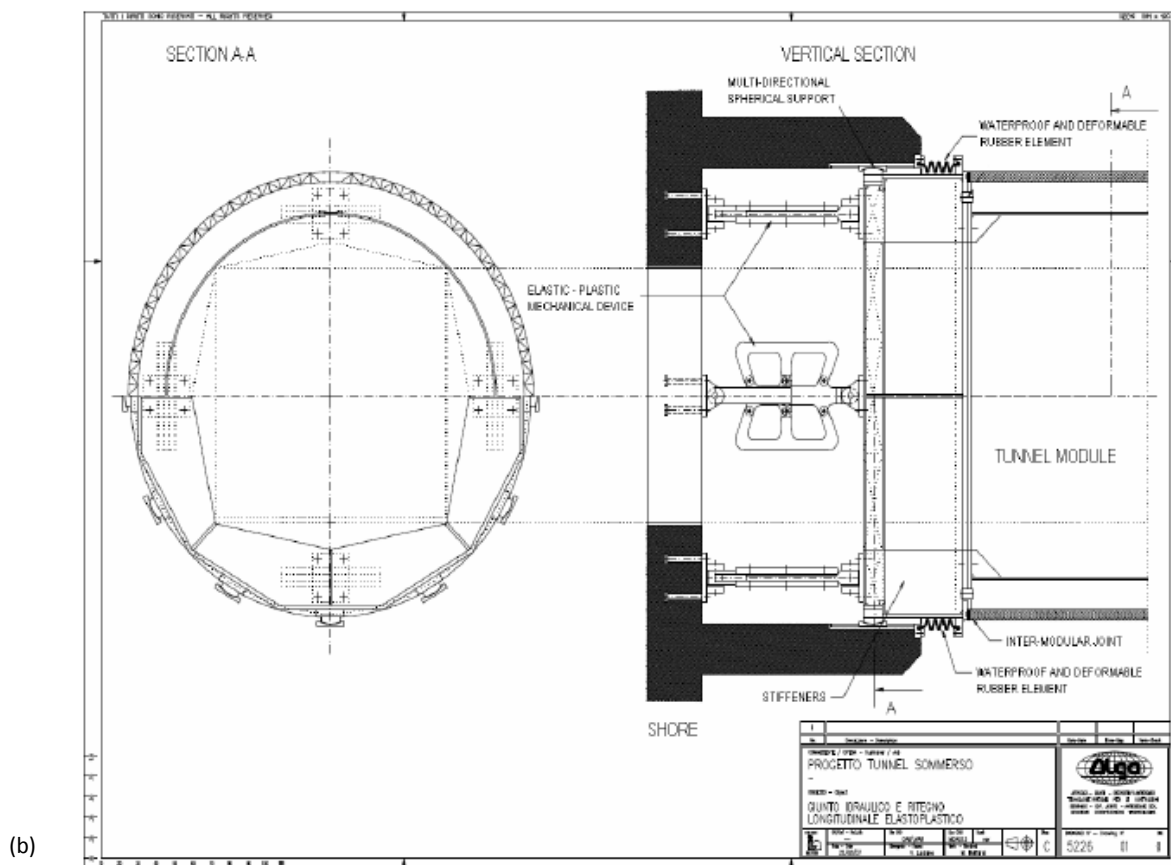

Figure 1.35 (b) Design of the shore connection for the AB prototype, Qiandao Lake, R.P. China (Mazzolani et al, 2007; ALGA)

Terminal joints represent a fundamental design issue also for Immersed Tunnels, for the same reason previously described for SFTs, in particular with respect to the seismic aspect. In fact seismic motions may control the design of the joint and its waterproofing detailing, as the terminal structure to which the end tunnel module is connected will (e.g., a ventilation building) will usually have a very different natural period of vibration than the tunnel, thus leading to large relative movements. This condition may require a full seismic joint with tri-axial motion capability (Grantz et al., 1997).

### 1.3.6. Access structure

As it is known the Submerged Floating Tunnel is located under the surface of the water crossing. The depth from the surface to the top of the SFT depends of the minimum clearance requirement for allow the shipping transit. Generally SFT are placed 20 to 30 m under the Mean Sea Level is enough for meeting the minimum clearance. In addition to the depth of the SFT under the water, it must be consider the height of the topography at shores. In some cases the shore presents rugged topography, which is at disadvantage for the access to the tube.

The typical solution is a bored tunnel as access solution. The tunnel has a gradient enough for match the SFT road deck to the land roadway. For connecting this bored tunnel is necessary a special joint as was studied in the section 1.3.5.2. A disadvantage of this solution is the large affectation area that the bored tunnel needs to meet the requirements for the maximum gradient allows for road tunnels. Furthermore, the time of construction of a bored tunnel can be considerably large in long tunnels. Another access structure that can be adapted to a SFT is the solution employed for Immersed Tunnels. IMTs generally use special access ramp for allow users driving from the land roadway to the Immersed Tunnel. A fact is that this method only applies when the position of the SFT with respect the surface is not very height, otherwise additional combination must be made. The Figure 1.36 illustrates the access ramp typically use in IMT. These access ramps are usually made by the cut and cover method using diaphragm walls.

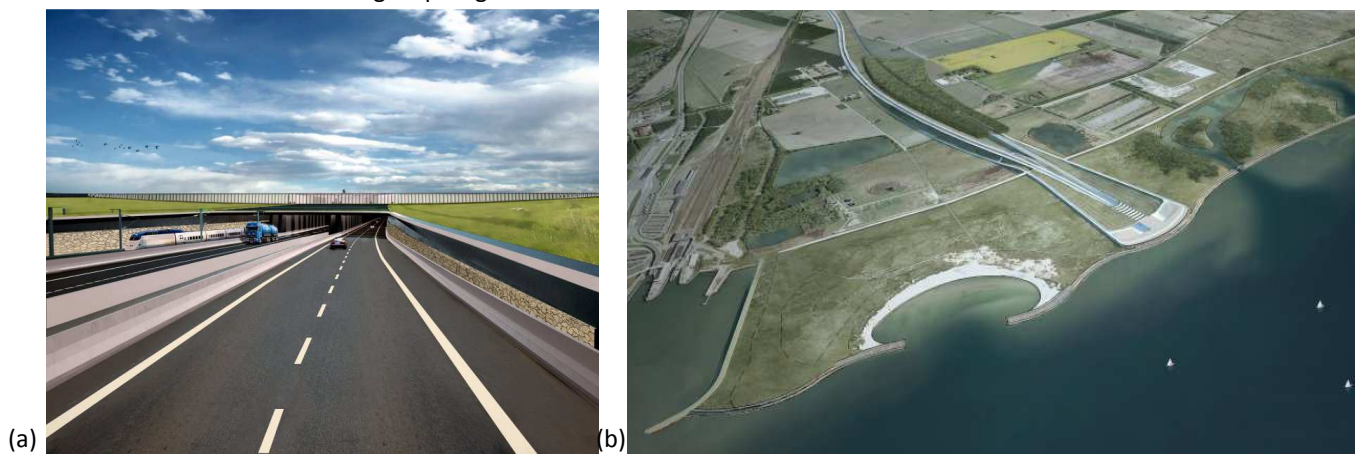

Figure 1.36 (a) Road lane view of the access ramp; (b) aerial view of the access ramp (Fehmarnbelt tunnel crossing, Fermen A/S)

A variation of this solution is proposed when the SFT is supported on piers as was studied in the section 1.2.4. The tunnel works with negative residual buoyancy and the cross section of the SFT can be the same for the IMT even when the tube approaches to the shore. And advantage of this combination is how it can be easily adapted the SFT to shallow water with and ordinary immersed tunnel. In fact, where a marine crossing consists of a combination of practical water depths for an immersed tunnel as well as an adjacent much deeper channel

it can be combined the two methods. Only the deeper section would need to be supported on piers whereas all the rest of the tunnel could be constructed as a standard immersed tunnel. The tunnel elements would be virtually the same except for the reinforcement and socket for the piers (Grantz, 2013). In the Figure 1.37 can be appreciate the solution when a SFT is combined with an IMT.

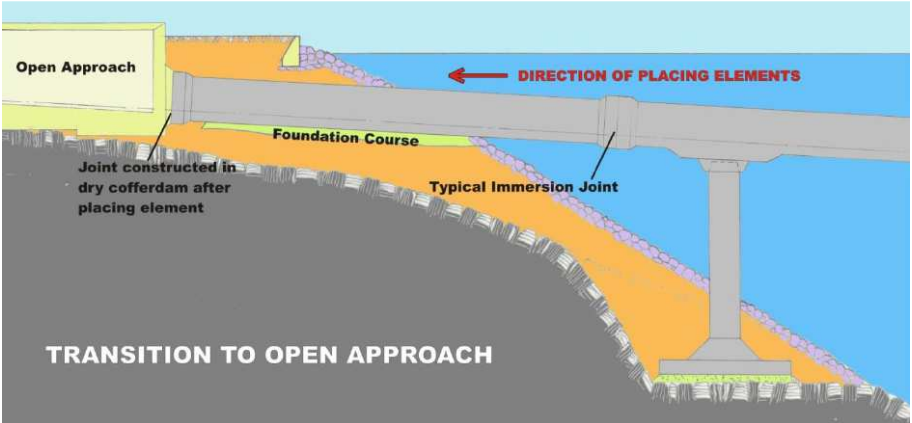

Figure 1.37 Scheme of the connection between the SFT supported on pier and the IMT (Grantz, 2013)

In addition, an innovative solution was proposed Mazzolani et al. for the AB prototype in China. The vehicular access structure has the shape of a “tube in tube” structure, made of two concentric vertical cylinders, and an helicoidally ramp in-between. The top of the cylindrical structure is covered by a “Chinese pagoda” shaped roofing structure, taking care of the architecture where the SFT is located. The cable stayed metal antenna at the top of the roof has the statical function of counterbalancing the Archimedes buoyancy on the access structure, which is partially immersed in the water: four steel cables from the top of the antenna are anchored to the ground for stabilizing the structure. Alternative solutions for this problem can be based on the use of ballast material or by founding the structure on piles, able to withstand both the lifting and horizontal actions. Although the helicoidally ramp can be exploited also for pedestrian use, the presence of a lift located into the internal vertical cylinder is envisaged. In the Figure 1.38 is presented the schemed of the solution for access to the SFT.

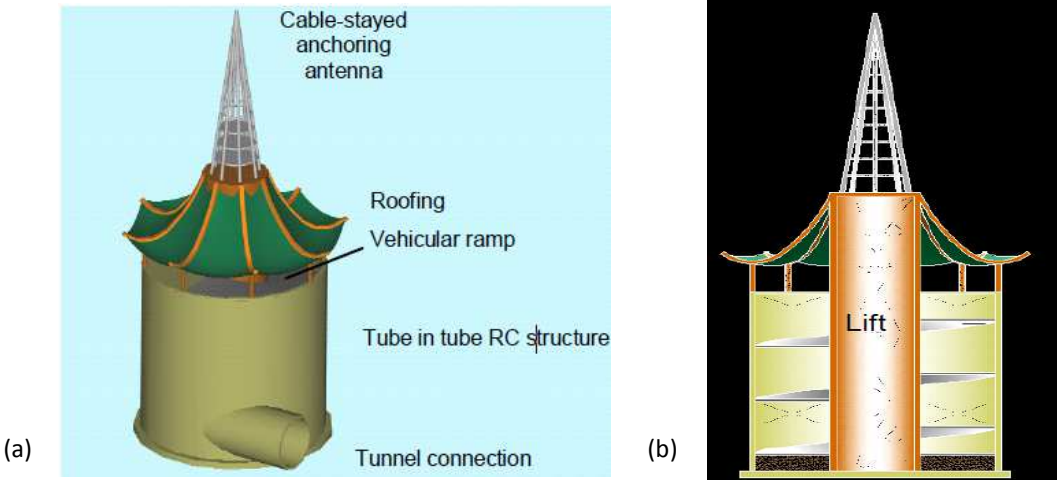

Figure 1.38 (a) Scheme of the access structure of the AB prototype in R.P. of China (Martire, 2010); (b) Details of distribution of the Access structure (Martire, 2010).

A similar solution is proposed by Dahl (2013) when is combined a Submerged Floating Tunnel with a Floating Bridge. In the point of view of the author this concept can be adapted for conventional bridges.

The solution consists of two cylindrical concrete platforms which are rigidly interconnected through a straight submerged concrete box structure. In the top of the structure is linked the floating bridge while the SFT is connected on the bottom (Figure 1.39). Thus the cars go from one structure to the other by a circular spiral road deck. For this solution special attention must be require on the geometric design of the structure, mainly in the maximum slope allowed for the passage of allowed vehicles, as well as the proper curvature to allow free movement of the cars. The Figure 1.40 shows a plan view of this access solution.

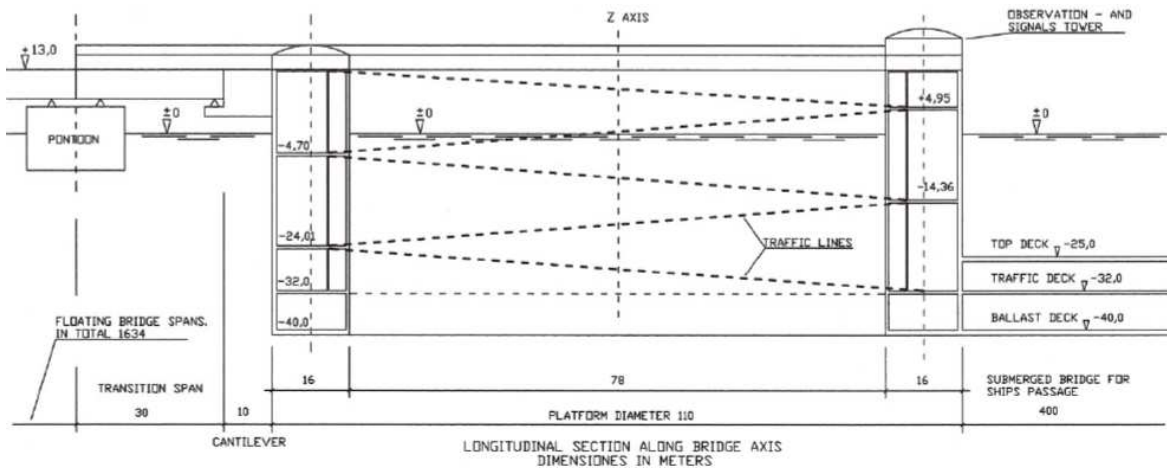

Figure 1.39 Lateral view of the floating access structure (Dahl, 2013)

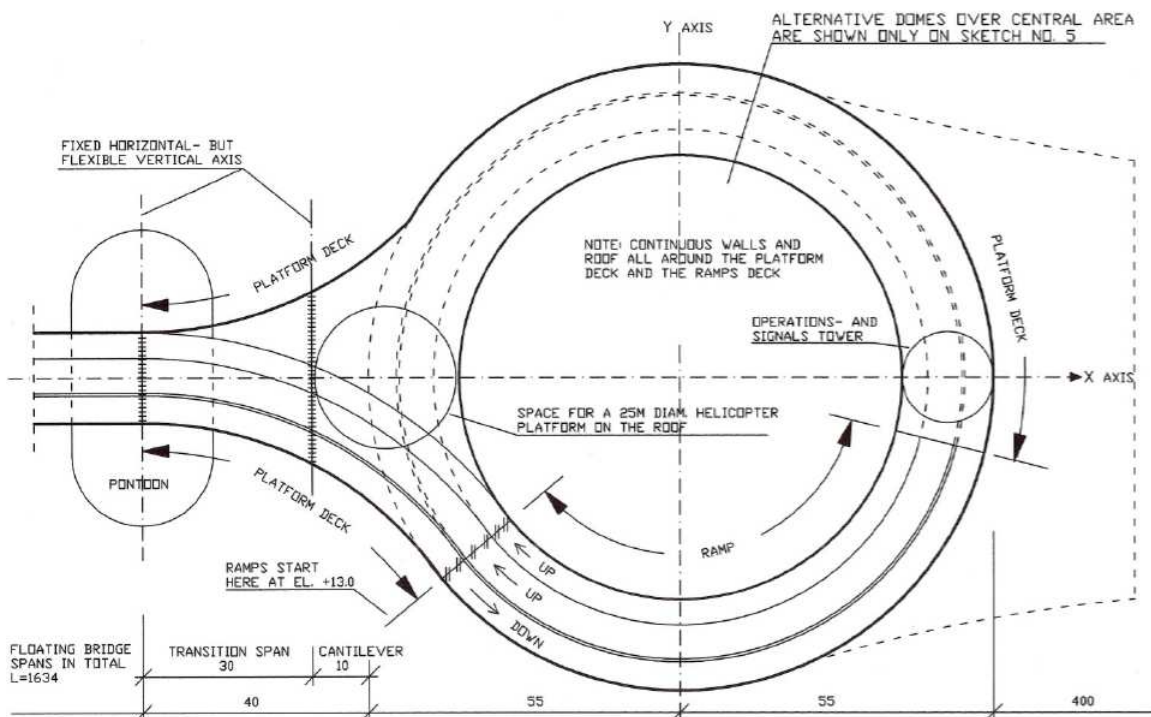

Figure 1.40 Plan view of the floating access structure (Dahl, 2013)



### 1.3.7. Evacuation Towers

In recent years the proposed of Submerged Floating Tunnel as waterway crossing solution has increased. In addition, there are some extreme crossing conditions where the solution is a SFT with very large length. Thus some additional devices from the safety point of view have been studied.

One of the main solutions in the latest years for very long SFT is the introduction of evacuation towers along the tunnel. These structures are placed in the tunnel at every specified distance and are equipped for evacuating. There are special platforms on the top of the towers where the users can be rescued in case of any dangerous incident inside the tunnel. The rescue platform usually is equipped with a heliport and in some proposals with special areas for resting. It could have the function as service station as well. Besides, from the structural point of view these structures could help for providing horizontal and vertical stiffness to the SFT. The Figure 1.41 shows the schemed of the evacuation towers for the SFT.



*Figure 1.41 Evacuation towers for a Submerged Floating Tunnel (Seo et al., 2013)*

The towers are provided with stairs for the evacuation. In addition, lifts are adapted for disable people be able to arrive to the top platform. Moreover, a shelter is proposed in the platform for the safety of people against bad weather. The Figure 1.42 and 1.43 show the sketch of these solutions.



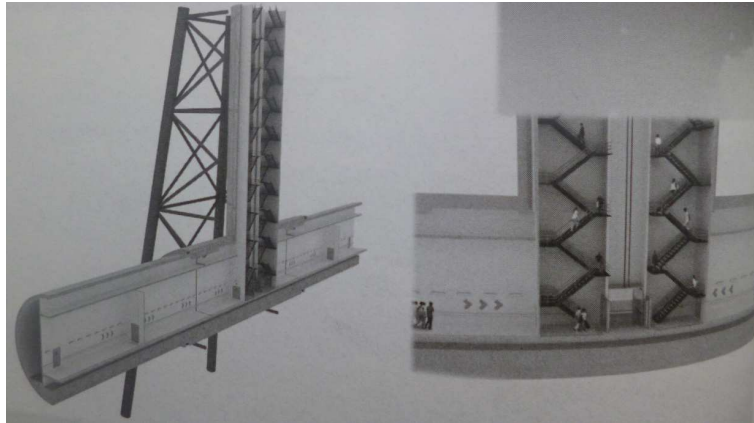

Figure 1.42 Details of the evacuation routes of the towers (Seo et al. 2011)

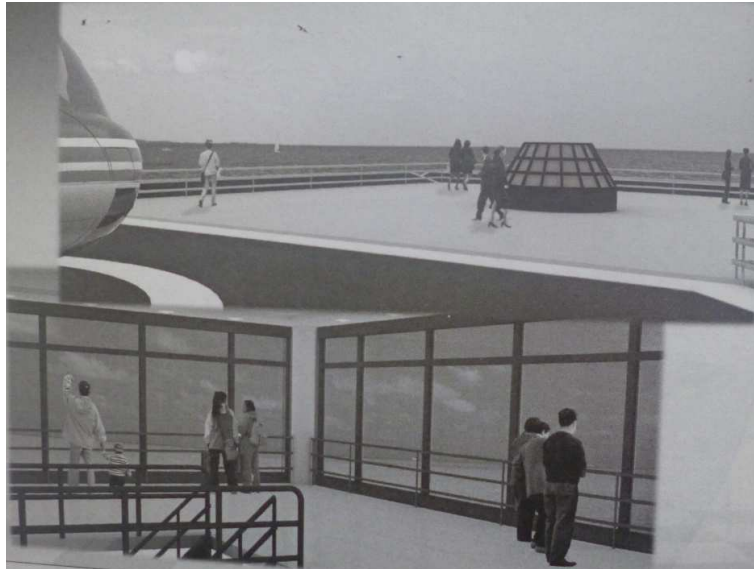

Figure 1.42 Shelter on the top platform of the towers (Seo et al. 2011)

#### 1.4. Structural design requirements

The structural design of a Submerged Floating Tunnel is a really complex task that designers must face. The proposed solution has to meet the basic requirements as any other crossing solution, being functionality and safety the main goals. One of the most important issues to be designed is the cross section of the SFT. The basic requirements that the cross section must meet are:

- a. The internal dimensions of the cross section should be large enough to accommodate the infrastructures, facilities and implants (ventilation, safety and fire systems, electrical implants) necessary to guarantee the normal development of the operations inside.
- b. The structure of the tunnel cross-section must be designed in order to ensure enough stiffness, strength, ductility so that the desired structural performances are met, in terms of functionality and safety. Moreover, waterproofing of the tunnel and its durability has to be assured
- c. The cross section has to be designed for the design value of the buoyancy ratio. The buoyancy ratio is the ratio between the buoyancy acting on the tunnel and the sum of the permanent weights and live loads. This value must be larger than the minimum buoyancy ratio under operation condition in order to keep the SFT on position. The table 1.7 shows the most typical buoyancy ratio used for the design of

SFT in both conditions, when the residual buoyancy is positive as well when the resultant force is negative.

Condition	Buoyancy Ratio <i>BR</i>	Proponent
Positive (upward force)	$1.2 \leq BR \leq 1.3$	Mazzolani et al.
Negative (downward force)	$0.5 \leq BR \leq 0.8$	Zhang et al.

*Table 1.7 Typical design values for buoyancy ratio*

- d. All the issues related to the production and erection of the tunnel modules have to be considered in the design.

The design value of the positive buoyancy ratio has been evaluated considering the load combination under vertical dead and live loads valid for the Ultimate Limit State, defined according to the Eurocode 0 provisions [CEN, EN 1990, 2002] (Mazzolani, 2001):

$$F_d = \gamma_g \cdot (G_k + B_k) + \gamma_q \cdot Q_k \quad (\gamma_g = 1.35; \gamma_q = 1.5)$$

Where:

- $\gamma_g, \gamma_q$  are the partial safety factor for dead and live loads, respectively
- $G_k$  is the characteristic value of the dead loads;
- $B_k$  is the characteristic value of the buoyancy;
- $Q_k$  is the characteristic value of the live loads.

In the first studies and preliminary design were considered very large values of the lower limit of the buoyancy ratio, up to 1.70. Numerical studies confirmed that larger values of the buoyancy ratio can improve noticeably the structural performance of the SFTs when they are subjected to severe environmental loading scenarios (Martire, 2010). Moreover, Brancaloni et al. (1989) found that increasing the buoyancy ratio from 1.25 to 1.40 can lead to impressive improvements of the SFT response to extremely severe sea states.

The Figure 1.43 provides a flow chart where is described the general process for the cross section design of a SFT. It considers the two conditions, when the residual buoyancy results in an upward force as well in the case of a downward force. In both cases is sought the design value of the buoyancy ratio. In addition when the preliminary design does not meet this requirement, the calculation of ballast could be the solution for satisfying the point.

In addition to the cross section design, the chart below considers the structural analysis of the SFT once the others structural issues of the tube are designed. It is taking account the anchorage system or the support system depending the decision made after evaluating the natural condition of the crossing.

Once the anchorage system or support system is designed can be realized the calculation as static analysis state of the SFT. It is recommendable the longitudinal analysis as well as the transversal analysis (Xiang, 2013). Then is designed the inter-modular joints and shore connection of the SFT for later realized the dynamic analysis of the whole tunnel.

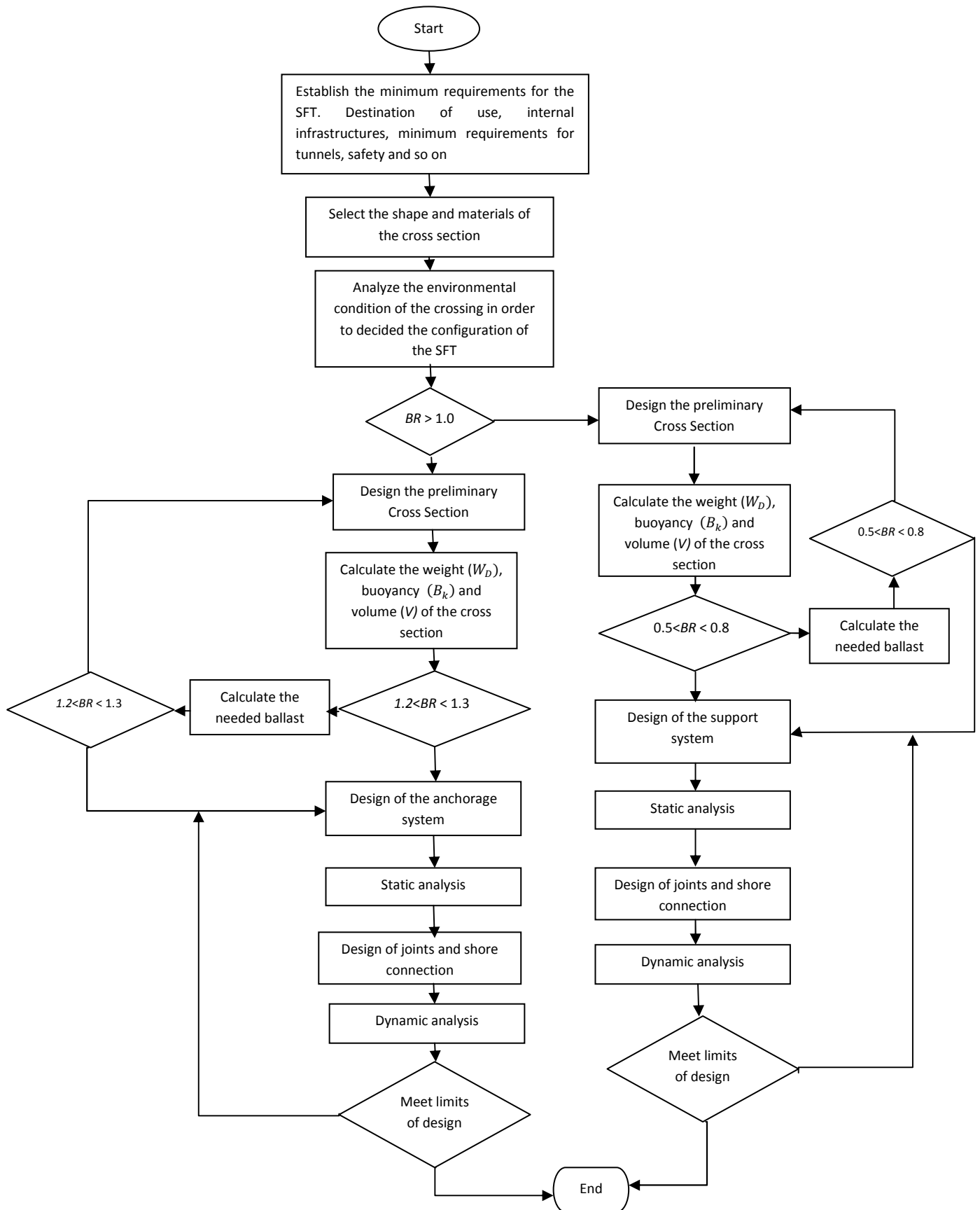

Figure 1.43 Flow chart of the design of a Submerged Floating Tunnel

### 1.4.1. Load conditions

#### 1.4.1.1. Permanent loads

Basically the permanent loads acting on the Submerged Floating tunnel are the self weight of the structure including the infrastructure necessary for the operation, the Archimedes buoyancy and the hydrostatic pressure.

The weight of the structure depends of the material property and its quantity along the SFT. The facility weight is proposed in function of the destination of use of the tunnel. Moreover, the Archimedes buoyancy as well as hydrostatic pressure depends of the specific weight of the water which in turn is dependent on its salinity.

The self weight per unit of the cross section of the SFT can be calculated with the follow equation (e1.1):

$$W_D = \sum \gamma_m A_m + W_f \quad (\text{e1.1})$$

where:

$W_D$  = weight of the structure per unit (kg/m)

$\gamma_m$  = specific weight of each material involve in the cross section (Kg/m<sup>3</sup>)

$A_m$  = area of each material involve in the cross section (m<sup>2</sup>)

$W_f$  = facilities weight (Kg/m)

The Archimedes buoyancy is obtained with the equation (e1.2):

$$B_k = \gamma_w A_{tot} \quad (\text{e1.2})$$

where:

$\gamma_w$  = specific weight of water. It is remarkable that this value is related to the salinity and temperature of the water. The salinity is generally measured as part per million (ppm).

$A_{tot}$  = Total area of the cross-section

The algebraic sum of the self weight of the structure and the Archimedes buoyancy gives as result the residual buoyancy of the tunnel. This value is a fundamental factor for the stability of the structure. The calculation can be expressed as:

$$RB_k = B_k - W_D \quad (\text{e1.3})$$

On the other hand, particular attention is required during the design step related to the design values of the SFT. In total agreement to Ahrens (1997), it has to be taken into account the following uncertainties:

- Tolerances in geometry and dimensions: the acceptable tolerances in the geometry and dimensions must be established during the design stage, depending on the choice of construction method, and controlled by the contractor during the construction. In case of significant variations from the weight design value, the ballast quantity can be modified at the end of construction.
- The specific weight of concrete: although the specific weight of concrete will vary during construction, it can easily be measured. Nevertheless, the acceptable range has to be established beforehand, during the design stage.

- The specific gravity of water: the specific gravity of the water can vary in a range which is characteristic of the site. These variations may be significant, in particular in coastal areas, and the design has to consider these variations.
- The amount and stability of marine growth: marine growth is known to concentrate at the sea floor and at the surface. If the SFT is not located in the critical surface layer, the effects of marine growth will be minor.

The aforementioned uncertainties lead to time variations of the residual buoyancy; in order to keep these variations under control, avoiding negative effects on the structural stability, it is possible to use water as ballasting material (or part of it) and counteract the weight changes by varying the amount of ballast water. This operation can be easily made through hydraulic pumps (Martire, 2010).

#### 1.4.1.2. Variable loads

The variable loads or functional loads are produced according to the destination of use of the SFT. As it is known a Submerged Floating Tunnel is proposed for pedestrian, roadway, railway or combination of these.

The amount of traffic occurring in the tunnel is subjected to great variations also during a single day, so that the definition of the associated loading conditions is quite difficult. Usually codes (e.g., Eurocode 1, part 3, UNI ENV 1991-3, 1991) define conventional loading conditions determined on the basis of statistical data gathering and analysis; these loading schemes are intended to reproduce the most onerous stress conditions produced by traffic loads on the structure.

The table 1.8 shows some values of variable loads that are proposed in the work of Martire (2010) according to the destination of use of the SFT.

<b>Destination of use</b>	<b>Variable Load Value (kN/m)</b>
Pedestrian	12
Roadway	720
Railway	840

*Table 1.8 Functional load values for SFT according to the destination of use*

#### 1.4.1.3. Environmental loads

##### 1.4.1.3.1. Hydrodynamic loads

The most significant actions related to the environmental condition where the Submerged Floating Tunnel is located are the currents and waves. These motions are relevant for the water-structure interaction and its analysis must be studied in detail. Therefore numerous observed data and theories are available to model the kinematics of water particles due to currents and waves. Many theories of hydrodynamic action impact have been applied widely in offshore structures as well as navigation vessels, thus this models can be adopted for the SFT.

## Currents

The analysis of motions due to currents in a water crossing usually considers two types:

- Wind generated currents: water motion is originated by the energy transferred to the water by the wind blowing over the water surface.
- Tidal currents: horizontal water motion resulting from the rise and fall of the water level due to tides (a vertical motion).

Usually water motion due to currents take place in the horizontal plane and can be assumed to be constant, as small variations in its velocity occur in a sufficiently long time period. However short and long term fluctuations around the velocity mean value occur, therefore when the former ones are significant they should be considered. Generally for design purposes, water current is modeled as a horizontal velocity distribution along the water depth; this distribution can be roughly assumed to be constant or, more generally, can be represented by as a polyline, thus requiring observed data relative to the current velocity at the depths of the polyline vertices (Martire, 2010).

An analytical distribution often adopted for the current velocity is the following:

$$V_c(z) = V_T \left( \frac{z+d}{d} \right)^{1/7} + V_W \left( \frac{z+d}{d} \right)$$

where:

$V_c(z)$ : Current velocity at a depth equal to  $z$  ( $z$  axis with the origin on the free surface and directed upward)

$V_T$ : Surface current velocity generated by tides.

$V_W$ : Surface current velocity generated by wind.

## Waves

Waves are generated by wind blowing over the water surface, but continue to exist after the wind action is ended; the size of the wind waves depends on three variables: the wind speed, the wind duration and the fetch (the exposure of the site to wind action). The idealized form of small amplitude waves in deep water is sinusoidal, whereas in shallow water the wave crests become steeper and the troughs flatter, the form tending to become trochoidal. In deep waters a single sinusoidal wave can be described by three parameters (CIRIA Underwater Group, 1978):

- Wave period  $T_w$ : the temporal distance between two crests or two troughs.
- Wave height  $H_w$ : the vertical distance from trough to crest
- Wave length  $\lambda_w$ : the geometric distance between two crests or two troughs, measured in the direction of propagation of the wave. Wave length is closely associated to wave period and to another wave property, the celerity  $c$ , being  $\lambda_w = c \cdot T_w$ . Moreover, there's a first order relationship between  $T_w$  and  $\lambda_w$ :

$$\lambda_w = 1.56 T_w^2 \quad (\lambda_w \text{ in meters and } T_w \text{ in seconds})$$

Several theories have been developed to describe the motion of water particles due to waves, which are generally based on the determination of the velocity potential satisfying the Laplace Equation, thus assuming an

irrotational and incompressible fluid. The table 1.8 explains the most common wave theories applied for the hydrodynamic analysis due to wave loads.

Theory	Features	Application
Airy Linear Wave Theory also called Sinusoidal	The wave height $H_w$ is small (Sarpkaya and Isaacson, 1981).	when the wave height $H_w$ is considerably smaller than both the wave length $L_w$ and the seabed depth $d$ . (Sarpkaya and Isaacson, 1981).
Stokes theory	The considered wave is not too steep and water depth is not too small (Sarpkaya and Isaacson, 1981)	when the wave height-to-length ratio is largely lower than one ( $H_w/L_w \ll 1$ ; (Peregrine, 1972)) and when the wave length $L_w$ is less than 8 times the water depth $d$ (Laitone, 1962).
Cnoidal Wave Theory	Waves with very steep and sharp crests and flat troughs	In shallow waters. When $d/L_w < 0.05$
Solitary Wave Theory	large wave length compare to the height	When $d/L_w < 0.05$
Linearized Long Wave or the Trochoidal Theory	Circular particle orbits, rotational fluid and trochoidal wave surface profile (Gerstner, 1802; Rankine, 1863)	It serves as a link from linear theory to the finite amplitude oscillation wave theory (Wilson, 2003) .

Table 1.9 Features of linear and nonlinear wave theories

The choice of the adequate wave theory should be done in dependence of the wave parameters. In fact each wave theory can be considered reliable in different fields of application in terms of wave height, wave period and seabed depth. In the Figure 1.44 can be appreciated the behaviour of the different wave theories

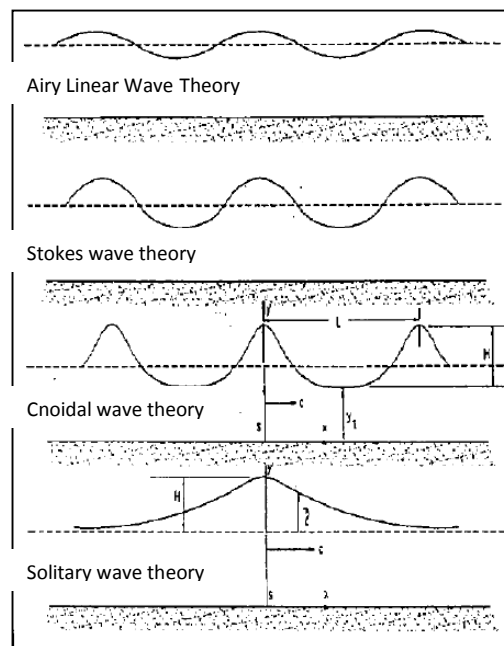

Figure 1.44 Comparison of the wave theories (Medina, 2009)

Many diagrams define the fields of application of the various wave theories. The Figure 1.45 shows a chart where is limited the application of each theory.

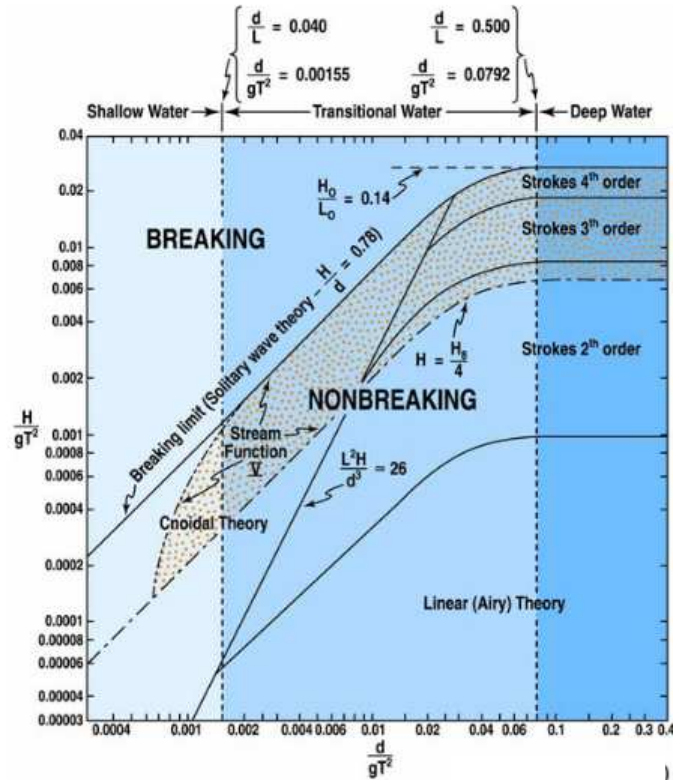

Figure 1.45 Range of validity of the different theories of wave (after Le Méhauté, 1976)

#### 1.4.1.3.2. Seismic loads

As any other structure a Submerged Floating Tunnel is subjected to earthquake motions. They must be considered in the design phase and particular attention must be taken in shore connections. In addition, when the SFT is configured to work with downward residual buoyancy, the anchorage will be affected by the seismic events, mainly in the shorter anchoring elements located close to the shores. In general, it is necessary to assure that every structural component remains safely in case of extreme seismic events and that functional performances are met in case of more frequent earthquakes.

The seismic actions must be characterized in the three dimensions on the basis of a careful seismological study of the crossing site, through analytical tools and available records from previous seismic events and can be modeled by means of design response spectra or ground motion acceleration. The former ones should be used only in case of moderately severe seismic events, as they are used in conjunction with a linear modal dynamic analysis which is thus unable to capture the non-linear structural behavior (Martire, 2010). Moreover, there is no way to introduce in a modal analysis with response spectrum the spatial variability of the ground motion, which can be particularly relevant for a SFT, whose connections with the ground can be considerably distant. Therefore the most suitable option is to model the seismic event through sets of ground motion time histories, consistent with the seismic hazard of the site and adequately accounting for the spatial variability, to be introduced in a dynamic (linear or, preferentially, non-linear) three-dimensional dynamic analysis. Moreover, dynamic analysis allow to directly introduce structural elements designed to exhibit a dissipative post-elastic behaviour during severe seismic events, such as, for instance mechanical or fluid-mechanical dissipative devices located at the shore connections (Martire, 2010).



Horizontal ground motion cannot propagate into water, but vertical ground motion waves can travel in it and this water motion should therefore be taken into account in SFT seismic analyses. Brancaloni et al. (1989) studied the propagation of seismic synchronous vertical motion in the water through a two-dimensional Finite Element model, accounting also for the incompressibility of the water and showed that the water motion can be assumed to be equal to the ground motion, thanks to the reduced compressibility of the water itself. In Martire et al. (2010a, b) dynamic analyses are carried out considering both the spatial variability of the ground motion and the propagation of its vertical component in the water layer, calculating the sets of ground motion time histories and the water kinematic field through a three-dimensional simulation of the seismic fault rupture and propagation of the generated waves in the ground and water layers.

#### 1.4.1.3.3. Tsunamis

The principal generator of a tsunami is the displacement of a substantial volume of water or perturbation of the sea. This displacement of water is usually attributed to earthquakes, landslides, volcanic eruptions, glacier calving or more rarely by meteorites and nuclear tests (Margaritondo, 2005). The waves formed in this way are then sustained by gravity. Tides do not play any part in the generation of tsunamis.

Tsunami waves are translational waves featuring very large wavelengths and small surface elevations in open water that can travel very long distances over entire oceans. Therefore SFTs may be exposed to Tsunamis even if the latter are generated very far from the SFT location. When Tsunamis reach shallow water near the shores, their height enormously increase. On the other hand Tsunamis periods are very long, so that their effects are significant also at large water depths, thus representing a potential serious hazard for SFTs.

An aid to model the action of a Tsunami in a SFT could be the use of the solitary wave theory in order to calculate impact that the phenomena could generate.

#### 1.4.1.4 Exceptional events

The concept of a SFT from the point of view of safety is similar to a conventional land tunnel. Inside the hazard is present at any time due to normal operation transit. On the other hand, the outer side is surrounded of water thus any impact either external or internal could provoke the flooding of the SFT, bringing a catastrophic event. Special considerations in the design must be taken for the design in order to minimize any flooding in the tube.

The hazardous events which a SFT is exposed are:

- Collisions due to dropping objects, sinking ships or impacts with submarines
- Rockslides
- Fire
- Car crashes or train derailments
- Terrorist attacks

Some studies of extraordinary events on SFT can be consulted on the next studies (table 1.9):

Topic	Author
Elastic-plastic capacity of a submerged steel bridge in case of impacts with sinking ships	Rambech et al. (1994)
Fire safety systems available for underground tunnels and applicable to SFTs	Fiorentino (2009).
Impact analysis of Submerged Floating Tunnel for conceptual design	Lee et al. (2013)
Global response of submerged floating tunnel against underwater explosion	Seo et al. (2013)
Simplified collision analysis method for submerged floating railway using theory of beam with elastic foundation	Seo et al. (2013)

Table 1.10 Studies related with exceptional events on a SFT

#### 1.4.2. Structural model solution

Structural models are formulations realized for solving engineering problems in the field of structural design. There are different chose for modeling an engineering problem, from a single model that can be use as preliminary design to a more complex model where all the details are consider. A fact is that nowadays exist advanced structural softwares which represents a great aid for solving really complex problems.

The structural model for a Submerged Floating Tunnel is generally realized by two ways:

- Analytical model. It is a simplified solution that can be used as preliminary design. Usually the SFT is analyzed as a beam on elastic foundation. It obtains the global behavior of the structure.
- Finite Element Model (FEM). It solves really more complex problems that the analytical models would be suitable for being applied. In the SFT analysis is ideal for study its response to dynamic excitation due to seismic events, storms, external impacts as well as the non-linear behavior of the anchorages and shore connections.

Firstly, whatever the modeling methods is selected, is realized the calculation of the geometrical properties of the cross section of the SFT. It is necessary obtain the Area ( $A$ ), Inertia Moment in axis X ( $I_x$ ), Inertia Moment in axis Y ( $I_y$ ), ultimate bending moment in axis X ( $MRd_x$ ), ultimate bending moment in axis Y ( $MRd_y$ ). Secondly, the geometrical properties and geometry of the anchorage system are calculated. In addition when the SFT is modeled by FEM is necessary to obtain the environmental motions according the section 1.4.1.3.

The analytical method is based as beam on equivalent elastic foundation (BOEF) (Figure 1.46a). Provided that the tunnel dimensions are small enough with respect to the crossing length, so that the tunnel can be suitably modeled as a beam, and that the ratio between the stiffness of the elastic supports represented by the SFT anchorage groups and the inter-axis between the anchorage groups are low enough with respect to the flexural stiffness of the tunnel, so that the retaining effect provided by the anchorages can be suitably considered to be distributed along the tunnel length (Martire, 2010).

The structural scheme of a SFT can be idealized as a Beam on Elastic Supports (BOES) uniformly spaced along the tunnel axis (Figure 1.46b). The transversal stiffness  $K_s$  of the elastic supports, in both the horizontal or vertical plane, can be easily determined on the basis of the mechanical properties and dimensions of the

anchorages and on the geometrical arrangement chosen for the anchorages groups. If the anchorage system is made up of cables, an equivalent Young's modulus can be considered to take into account the catenary effects. The passage from the model of BOES to the one of BOEF can be made by replacing the discrete elastic supports by a continuous elastic foundation whose stiffness modulus  $K_s$  is obtained as the ratio between the stiffness of the supports  $K_s$  and the inter-axis  $i$  between the supports (Figure 1.46c) (Martire, 2010).

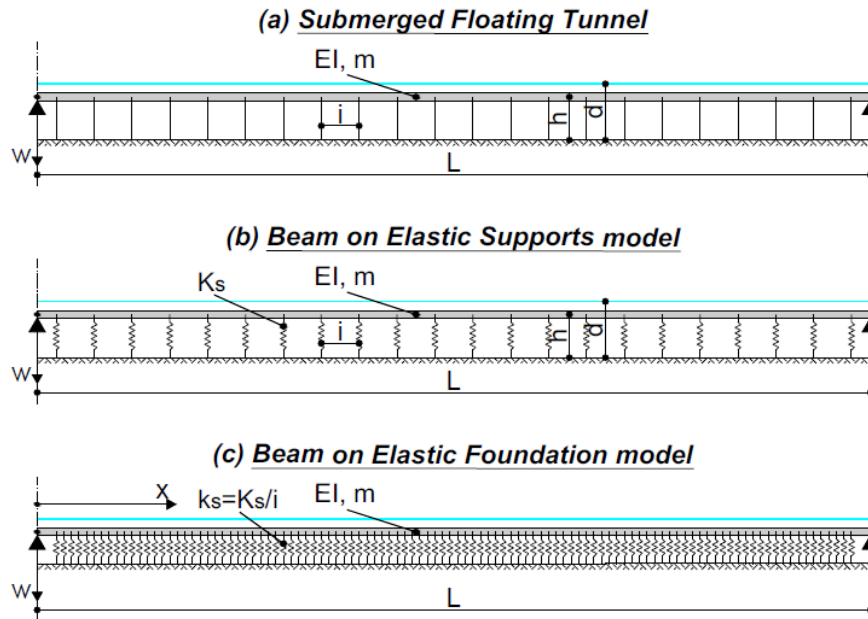

Figure 1.46. Idealization of a SFT as a Beam on Elastic Foundation: (a) real structure; (b) Beam on Elastic Supports (BOES) structural model; (c) Beam on Elastic Foundations (BOEF) structural model (Martire, 2010)

On the other hand, the used of Finite Element Method (FEM) is appropriate to analyze the dynamic behaviour of a SFTs. In the work carried out by Martire et al. (2007), the SFT is modeled through tri-dimensional quadratic beam elements. As the tunnel cross sections have particular geometric configurations and in some cases the SFT is a composite structure, thus it has been introduced in the structural model by assigning to the tunnel beam elements their geometrical properties, which have been determined considering concrete sections equivalent to the steel-concrete composite structures. The cross section area has not been set equal to the one of the considered concrete equivalent cross section but it has been evaluated through an equivalence in terms of weight, taking into account all the permanent gravity loads acting on the tunnel (Martire, 2007).

Cables are structural elements which are unable to transmit bending moments and compressive axial force; their behaviour cannot be modeled through truss elements, because they cannot simulate the incapacity to absorb axial forces of compression and no transverse loads can be applied to them, so that hydrodynamic forces should be ignored in the model. For the aforementioned reasons, also the cables have been modeled by means of beam elements. By this way the hydrodynamic loadings can be considered and the cables mechanical behaviour can be simulated in an effective way: in fact, by assigning to the beam elements fictitious very low values of the cross section moments of inertia and by considering geometric non linearity in the analyses, no compressive force can be carried by the cables in the model, since buckling immediately occurs; moreover, the flexural stiffness approximates to zero, as it should be (Martire, 2007). The Figure 1.47 shows how the model is displayed by the software ABAQUS, which was utilized for the described analysis.

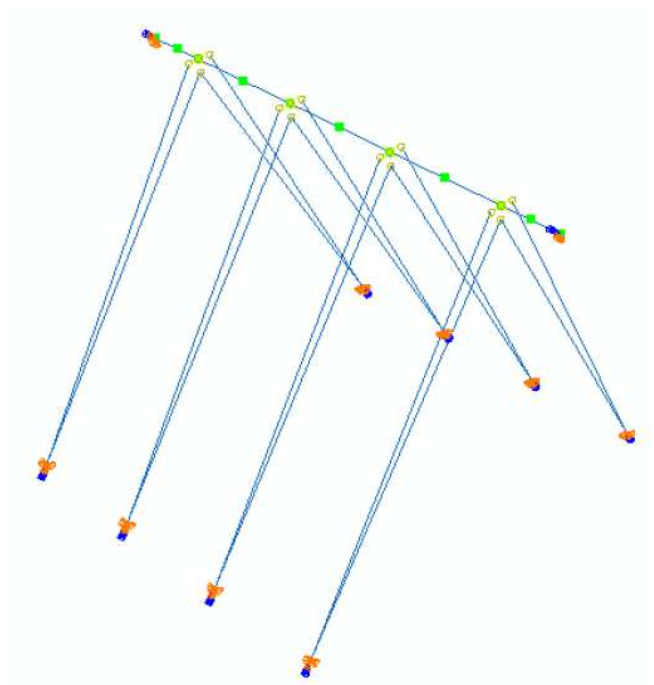

Figure 1.47 Example of a Finite Element Model (Martire, 2007)

## Chapter 2

### Design requirements for road tunnels

A tunnel can be defined as a passageway completely enclosed except for openings for entrance and exit, commonly at each end. In addition tunnels provide emergency exit for evacuation in case of incidents during normal operations. These passages depend of some features of the tunnel, mainly its length and the destination of use. Starting from the tunnel concept, a Submerged Floating Tunnel independently of its external configuration, inside must be considered and designed as any other conventional tunnel.

Tunnels, initially aimed at crossing an obstacle (in general a mountain), have become increasingly complex during recent years, incorporating increasingly complex equipment (including ventilation systems) and methods of operation. Such operation includes the deployment of control and supervision systems that able to handle tens of thousands of items to be controlled, and which can accommodate increasingly sophisticated management scenarios.

Nowadays tunnels represent a crossing solution even for water crossings. Some typologies of tunnels as subsea tunnels and immersed tunnels are examples of the enclosed structures which are employed as waterway crossing solution around the world (The Figure 1.1 provided a sketch of both configurations). Furthermore, the improvement of tunnel technology has aided to realized more complex projects, either under extreme conditions as well as longer than early years when it would not possible their execution.

Considering the SFT proposal of the present work, the interest is focus on tunnels used as roadway, base on the consideration that the SFT of the Gulf of California is destined for roadway.

#### 2.1. Typology

In general the inner configuration of a tunnel is the same. The internal geometry must large enough to house the traffic lanes, ventilation system, emergency exits, and the many other minimum requirements of tunnel codes. The safety of the user is the primordial task for tunnels design. A fact is that driving in tunnels is actually twice as safe as driving in the open air, when all factors are taken into account (SINTEF, Jensen).

The different between the typologies in tunnels remain mainly in the destination of use, crossing solution, and position with respect to the seabed. The current typologies of tunnels are shown in the chart of the Figure 2.1.

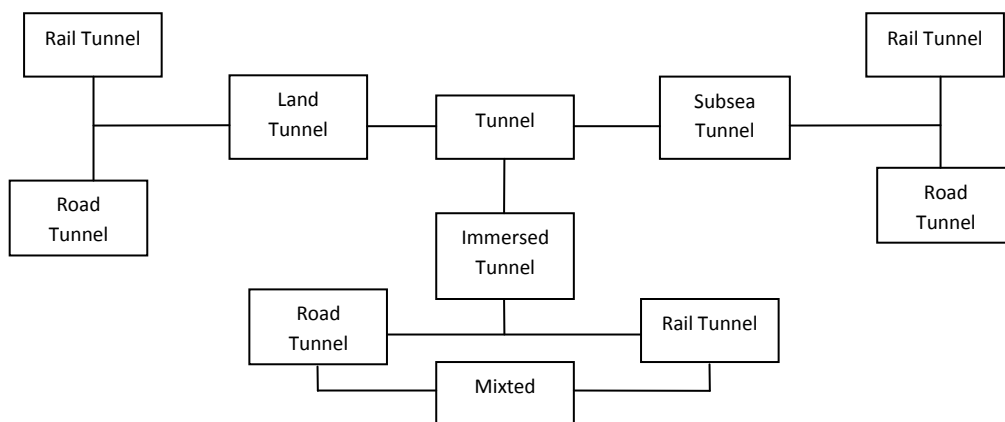

*Figure 2.1 Chart of tunnel typologies*

### 2.1.1. Land Tunnel

It is the most typical configuration of tunnel. The land tunnels are underground conduits constructed in order to allow vehicles transit more easily especially in rugged topography. They are increasingly used to cross natural barriers such as mountains. In addition tunnels are employed in urban areas for specific task as city underground crossing or underground rail systems. Furthermore, application as water conduct or sewers can be seen. They are distinguished from open roads in respect of conditions such as: little or no lateral movement, other winter conditions, regular lighting throughout the day and year (except from the entry zone), difficulties in estimating gradients, difficulties in estimating distance to vehicle in front, other safety measures, breakdown services, etc.

The land tunnel can be employed as a roadway or railway. Usually tunnels employed for train's passage are longer than road tunnels.

A tunnel can be defined as a part of a way located between solid structures, where the users have limited possibilities of escape in case of internal accidents, and the air inside depends on a number of specific factors, such as geographic location, geometry, equipment, power supply, as well as the volume and composition of traffic, vehicle quality, driving characteristics and the operation of the facilities. Usually are for public use and inside are provided of additional equipment intended to ensure the safety of users such as ventilation system which is destined to maintain a hygienic air and good visibility to detect any obstacles on the road.

These require that a number of design elements will differ to those of the open road. Maintenance and operations shall ensure a constant level of safety in the tunnel. The tunnel categories are the basis for a specific cross-section, number of traffic lanes, need for emergency lay-bys and turning points together with safety equipment. The Figure 2.2 shows the main components of a typical cross section in a land tunnel.

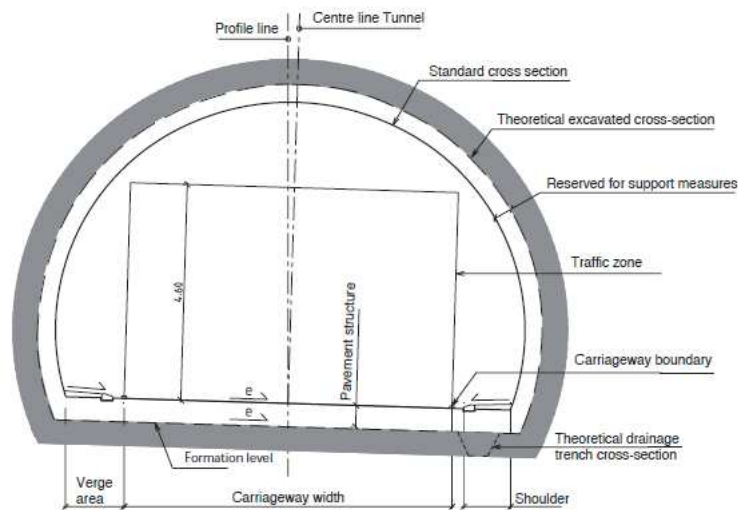

Figure 2.2 Tunnel Cross section (NPRA, Norway)

The improvement of tunnel engineering has lead to realize more complex projects. Furthermore, construction methods employed nowadays allow execution of projects with shorted schedule.

### 2.1.2. Subsea Tunnels

Subsea tunnels are galleries bored in the under the seabed and represent a crossing solution widely used in the past and still of great importance in waterway crossings practice. They are generally preferred to bridges when large distances have to be surpassed and intermediate piers could not be placed along the crossing path because they would interfere with the navigating vessels or the great depth of the water crossing. In addition when the urban zones adjacent to the crossings are densely built and populated, the ramps at its ends have a minor affectation area than a bridge solution.

It can be employed as railway solution as the probably the most famous project the Channel Tunnel which links the United Kingdom with France or for roadway proposes as 32 subsea road tunnels in the Scandinavian country of Norway (Øvstedal, 2013).

### 2.1.3. Immersed Tunnels (IMT)

An immersed tunnel is a kind of underwater tunnel composed of precast segments, constructed elsewhere and floated to the tunnel site to be settled on the seabed and then linked together. They are commonly used for road and rail crossings of rivers, estuaries and sea channels/harbors. Immersed tubes are often used in conjunction with other forms of tunnel at their end, such as a cut and cover or bored tunnel, which is usually necessary to continue the tunnel from near the water's edge to the entrance (portal) at the land surface.

It being a precast structure fabricated in a dry yard and transported to the location to be assembled in situ, it seems to be the most similar crossing solution to a SFT. Most details of this typology of waterway crossing are studied in section 2.4.

## 2.2. Existing tunnels around the world

Nowadays tunnel are a very common solution for crossing natural obstacles. Mountains as well as lakes or sea are crossed through tunnels. The improvement in tunnel technology has lead to realize more complex projects even under extreme natural conditions. The different configurations of tunnel are employed around the world and their design since the geometrical and safety point of view is a particular interest for the SFT design. The SFT of the Gulf of California represent a real challenge for the tunnel engineering. It represents a really complex project which is so far from the tunnels that are built until these days. However, the different project of tunnels must be studied with the task of collect the information of the geometrical requirements as well as the safety considerations carried on. In this section are studied the longest projects of tunnels in the world mainly the road tunnels.

It is important to remark that some of the tunnels listed here below are under construction or planning stage thus is noted for each particular case. Furthermore, due to the big amount of tunnels in the world, are study the longest and most significant projects with innovative solutions.

### 2.2.1. Rail Tunnels

Usually the longest tunnels in the world are for railway use. However, it is important study the solutions that were taken to crossing the diverse obstacles. Moreover, the safety as well as the emergency considerations has

to be taken in account in the design of the SFT in the Gulf of California, once it represents a really long solution. So, here are listed the longest and representatives railway tunnels in the world either for land and subsea crossing.

a. Gotthard Tunnel

The Gotthard Base Tunnel (GBT) is a railway tunnel under the Swiss Alps considers the world’s longest rail tunnel. The GBT consists of two 57-kilometres-long single-track tubes. These are connected together every 325 meters by cross passages. Including all cross-passages, access tunnels and shafts, the total length of the tunnel system is over 152 km (AlpTransit). It joins the north portal at Erstfeld to the south portal at Bodio. It is expected to open in 2016.

From the safety point of view in the tunnel are located two multifunction stations at Faido and Sedrun divide the two tubes into three approximately equally long sections (every 19 km). Each multifunction station contains emergency stop stations and two track crossovers for changing between tubes in case of incidents. The doors of these emergency stop stations have a dual function: they can be opened and closed to regulate the fresh-air flow and also serve as escape doors. In addition multifunctional station of Sedrum a access gallery is provide with lifts which can be used for evacuation in case of fire or incidents (Figure 2.3).

The operational ventilation prevents an unfavorable climate in the tunnel system and provides the necessary air conditions for personnel involved in maintenance work. In the event of a fire in the tunnel, it can suck fumes out and blow fresh air in. In the Gotthard Base Tunnel, ground water and tunnel water flow out of the tunnel in special pipes. Before it flows out, the tunnel water is examined, processed to the extent necessary, and returned to the natural environment. In the event of soiled water collecting in the area of the trackbed, at 100-metre intervals it is collected in a shaft and drained into a separate pipeline. The soiled water runs into a collection basin outside the tunnel, where it is analyzed.

In general the technical infrastructure systems comprise ventilation, water supply and drainage systems, ventilation and air-conditioning systems for auxiliary structures and buildings, cranes, doors, technical floors and metal structures, as well as electrical and fire-protection installations.

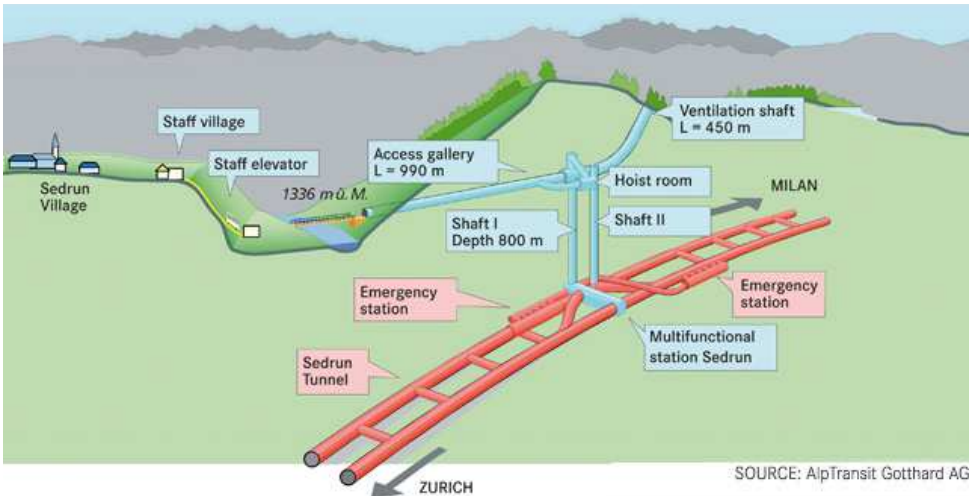

Figure 2.3 Sketch of Gotthard Base Tunnel (AlpTransit Gotthard)

b. Brenner base tunnel

The Brenner Base Tunnel (BBT) is a railway tunnel through the Brenner Pass in the Alps which connects the Austrian city of Innsbruck with the Italian town of Fortezza. It will have a length of 55 km, which will make it the



second longest railway tunnel in the world upon completion (2025), surpassed only by the Gotthard Base Tunnel.

The BBT consists of two tubes, each 8.1 m wide, running 70 m apart from one another. These tubes are each equipped with a single track, meaning that train traffic through the tubes is one-way. The two tubes are linked every 333 m by transversal tunnels. These can be used in emergencies as escape routes. This configuration conforms to the highest security standards for tunnels (BBT SE).

A peculiar feature of the Brenner Base Tunnel is the exploratory tunnel running from one end to the other. This tunnel lies between the two main tunnels and about 12 m below them and with a diameter of 5 m is noticeably smaller than the main tubes. At the end this exploratory tunnel will be used as a drainage and service tunnel (See Figure 2.4).

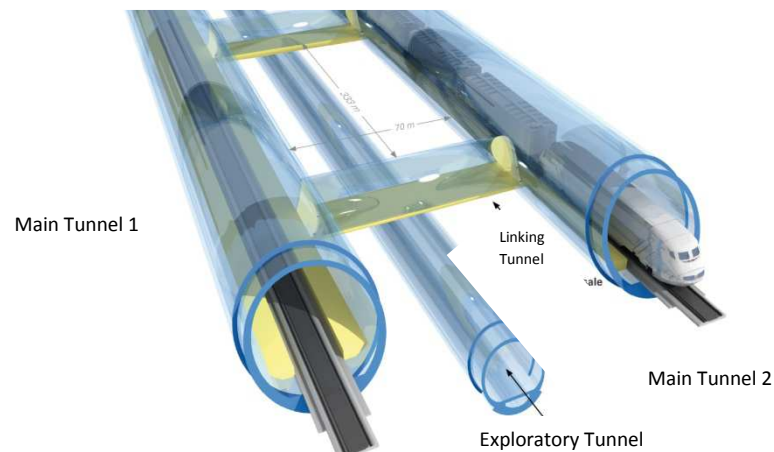

Figure 2.4 Drawing of the Brenner Base Tunnel (BBT SE)

### c. Seikan Tunnel

The Seikan Tunnel is an extremely long undersea tunnel with a length of 53.85 km that links Hokkaido and Honshu, which are two of the main islands of Japan. It is the third longest tunnel in the world and the world's second subsea tunnel with an undersea portion of 23.3 km.

The cross section of the tunnel is a horseshoe shape capable of supporting a double rail track with 9.7 m wide and 7.85 m high. At 30 m from the main tunnel is located a service tunnel which is used for maintenance and allows for bicycle and motor traffic. In addition was excavated a pilot tunnel used for surveys on marine geology and groundwater flow and to examine and develop excavation methods in preparation for the construction of the service and main tunnels which currently its roles are draining and ventilation. Furthermore, there are groups of vertical and inclined shafts that are employed as gas exhaustion ducts and air duct for ventilation respectively. In Figure 2.5 is shown the distribution of the components of the Seikan tunnel. It can be appreciated a connecting tunnel between the service and main tunnel placed every 600 m.

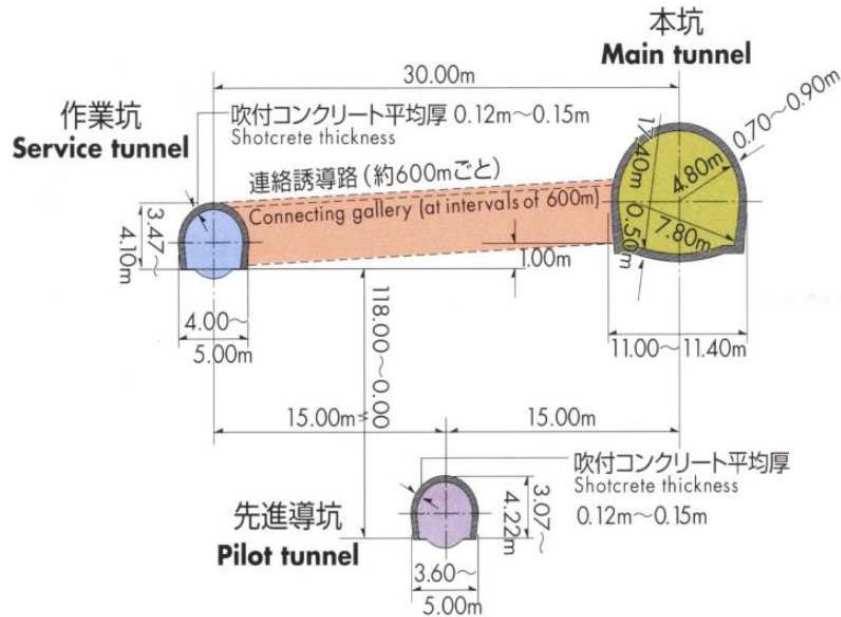

Figure 2.5 Seikan tunnel cross section (JR Hokkaido)

The groundwater is drained to the lowest point near the centre of the tunnel and channeled up over the land by pumps to three drainage areas. The world's first undersea stations – Yoshioka Kaitei and Tappi Kaitei – also serve as emergency stations. If the fire detector inside the tunnel detects abnormally high temperatures, the trains stop immediately at the nearest station. The passengers are guided from the platform via the connecting gallery to a fire shelter, where ventilation is ensured. The whole area of the escape way is equipped with lighting, 75 TV cameras, and a public address system with 173 speakers. There are hydrants capable of providing water at 7 t/min for 40 min. In addition a private power generation system has been introduced to ensure a power supply in emergencies (Sato et al. 2013). If an earthquake of a certain magnitude should occur, all trains in the tunnel stop automatically.

#### d. Channel Tunnel

It is one of the most famous tunnels in the world. It connects the city of Folkestone in the United Kingdom and Coquelles in the north of France. It has a total length of 50.5 km of which 37.9 kilometers runs under the seabed. Hence, the Channel Tunnel became the fourth longest tunnel in the world and the world's longest undersea one. The tunnel carries high-speed passenger trains, Shuttle roll-on/roll-off vehicle transport (the largest in the world) and international rail freight trains.

The tunnel is formed by two main tunnels running parallel at 30 m distance, lined diameter is 7.6 m, excavated diameter is 8.8 m. Each running tunnels houses a single line rail track, overhead catenary, power supply, drainage, cooling pipes, two walkways, and auxiliary services. In addition a service tunnel of excavated diameter of 5.8 m is located between running tunnels, it provides access to these in both normal and emergency conditions. The Service Tunnel Transportation System includes 24 rubber-tyred vehicles rolling (top speed 80 km/h) on cast-in-place concrete, electronically guided by an embedded cable. It allows maintenance of permanent equipments (Pompée). The distribution of the tunnels can be appreciated in Figure 2.6.

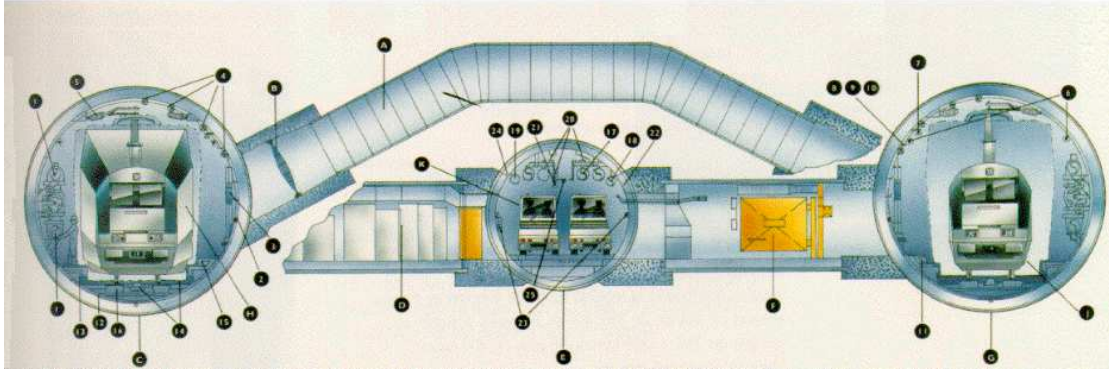

Figure 2.6 Cross section of the Channel Tunnel (Pompée)

The special underground works and mechanical systems of the Channel Tunnel are:

- 2 undersea huge crossover caverns (160 m long, 180 to 270 m<sup>2</sup> cross section), located at the third points of running tunnels, enabling a train to cross from a tunnel to another, to close tunnel sections to traffic during maintenance.
- 270 cross passages of 3.3 m internal diameter, every 375 m, between service tunnel and running tunnels.
- 194 piston relief ducts (2.0 m internal diameter), linking running tunnels every 250 m
- 156 electrical rooms, and 58 signalling rooms (internal diam 3.3 to 4.8 m), housing fixed equipment for power supply and control and communications, lined with cast iron or concrete, accessible from service tunnel only.
- 5 pumping stations.

The three tunnels contain 6,000 tonnes (6,600 tons) of air that needs to be conditioned for comfort and safety. Air is supplied from ventilation buildings at Shakespeare Cliff and Sangatte, with each building capable of full duty providing 100% standby capacity. Supplementary ventilation also exists on either side of the tunnel. In the event of a fire, ventilation is used to keep smoke out of the service tunnel and move smoke in one direction in the main tunnel to give passengers clean air. The Channel Tunnel was the first mainline railway tunnel to have special cooling equipment. Heat is generated from traction equipment and drag. The design limit was set at 30 °C, using a mechanical cooling system with refrigeration plants on both the English and French sides that run chilled water circulating in pipes within the tunnel (Kirkland, 2002)

A special firefighting system was created in the tunnel. The wagon door systems are designed to withstand fire inside the wagon for 30 minutes, longer than the transit time of 27 minutes. Wagon air conditioning units help to purge dangerous fumes from inside the wagon before travel. Each wagon has fire detection and extinguishing system, with sensing of ions or ultraviolet radiation, smoke and gases that can induce halon gas to extinguish a fire (McFarlane, 2008). Since the Heavy Goods Vehicle (HGV) wagons are not covered, fire sensors are located on the loading wagon and in the tunnel itself. In addition the tunnel is equipped with two Service Tunnel Transportation System (STTS) vehicles with firefighting pods are on duty at all times, with a maximum delay of 10 minutes before they reach a burning train (Kirkland, 2002).

e. Lotschberg base tunnel

The Lötschberg Base Tunnel (LBT) is a 34.57-kilometre railway tunnel crossing the Alps of Switzerland. It is currently the world's longest land tunnel and accommodates passenger and freight trains. It runs between Frutigen, Berne, and Raron, Valais. The operation began in December 2007. It was designed with twin single-track tubes to ensure optimum reliability, but for financial reasons, only one of the tubes was fully equipped, while the second was left largely as a shell. The two tubes are connected by transverse tunnels at 333-metre intervals, meaning that each main tunnel serves as the evacuation tunnel of the other. All systems are duplicated in the tunnel. This "twin installation" means that operations can continue in the event of any

technical problems (BLS). There are a total of 12 operations centres housing technical installations along the base route between Frutigen and Raron. All operations centres are constructed in pairs for security reasons, with one each in the eastern and western tunnels, so that each tube is capable of being operated independently. The 108 connecting tunnels that connect the two tunnel tubes serve as escape routes and also house a total of 1450 cabinets. These contain installations for electricity supply, maintenance and emergency lighting, data transmission, door control, and safety and wireless communications installations.

The tunnel as a whole is equipped with three ventilation control centres: two air supply centres and one air extraction centre, as well as eight jet ventilators at each of the tunnel's entrances. This allows a total of 17 different ventilation scenarios to be employed, each geared towards the respective operating situation. The air extraction system is employed only in emergency situations and removes polluted air, such as smoke, via the Fystertella ventilation shaft. In addition, the climatic environment and smooth functioning of the electronic equipment is ensured by means of 44 refrigeration units and 396 air circulation cooling units.

On the other hand, water management includes the tunnel's water supply, drainage and the environmentally friendly treatment of the waste water. Tunnel drainage is carried out via a separated system that runs through the entire rail tunnel system and distinguishes between mountain water and waste water.

The base tunnel's communication systems contain data lines, a telephone system connected to the public telephone network (via tunnel operating) and GSM-R wireless communications for train data and voice communication. Every connecting tunnel and tube is equipped with emergency telephones. The GSM-R wireless communications system functions throughout the entire tunnel. Furthermore, more than 100 cameras monitor events in the tunnel. All technical facilities, the cross passages, access and service tunnels and the drainage system are equipped with fire, gas and flooding sensors, depending on their location. This allows rapid, targeted intervention in emergency situations. The distribution of the facilities, operation centres and the whole tunnel system is shown in the Figure 2.7

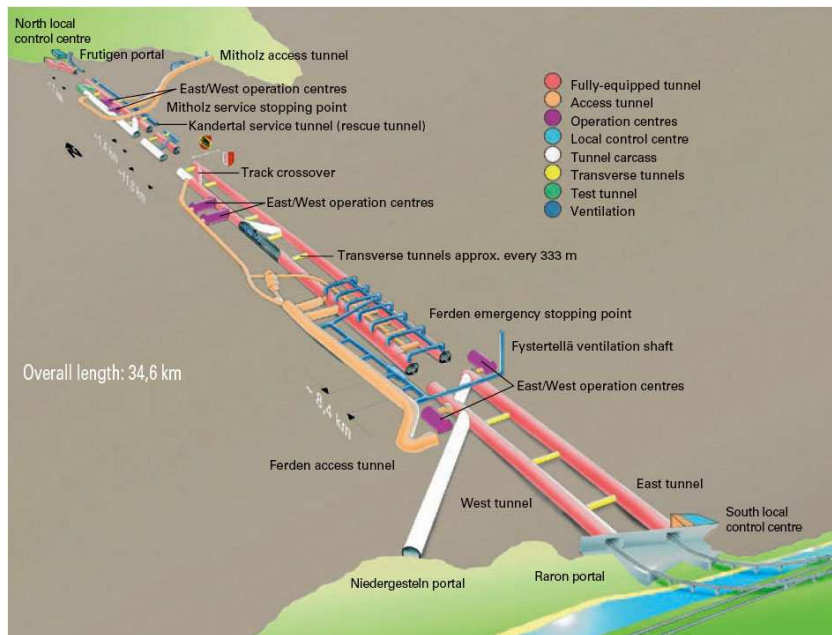

Figure 2.7 Drawing of the Lotschberg base tunnel (BLS)

f. Koralm tunnel

The Koralm Tunnel is a railway tunnel that is under construction in Austria under the Koralmpe mountain range at a depth of 1200 m. Its length of 32.8 km makes the Koralm tunnel the longest railway tunnel located entirely

within Austrian territory which connects the cities of Graz and Klagenfurt in the south of Austria. It is expected to be in operation until 2022.

The configuration of the tunnel system consists in:

- Two single-track tubes each with a cross-section of 52 m<sup>2</sup>.
- Cross-passages connecting the tubes every 500 m.
- One emergency station in the centre of the tunnel with no direct link to the surface.
- No crossover inside the tunnel.

The emergency station in the centre of the tunnel consists of 400-m-long platforms in both tunnel tubes (Figure 2.8). For this emergency station, the walkway, which extends over the entire length of the tunnel, is widened and raised to the level of the platform (55 cm above top of rail). The walkway and the emergency exits may thus be kept on the side facing the second tube. The emergency stations must be equipped with: emergency telephone, video surveillance and loudspeaker system for announcements, lighting system comparable to that of a station, seating accommodation, the provision of separate areas for the treatment of injured persons. Toilets are a possibility to be provided as well (Neuman, ILF consulting engineers).

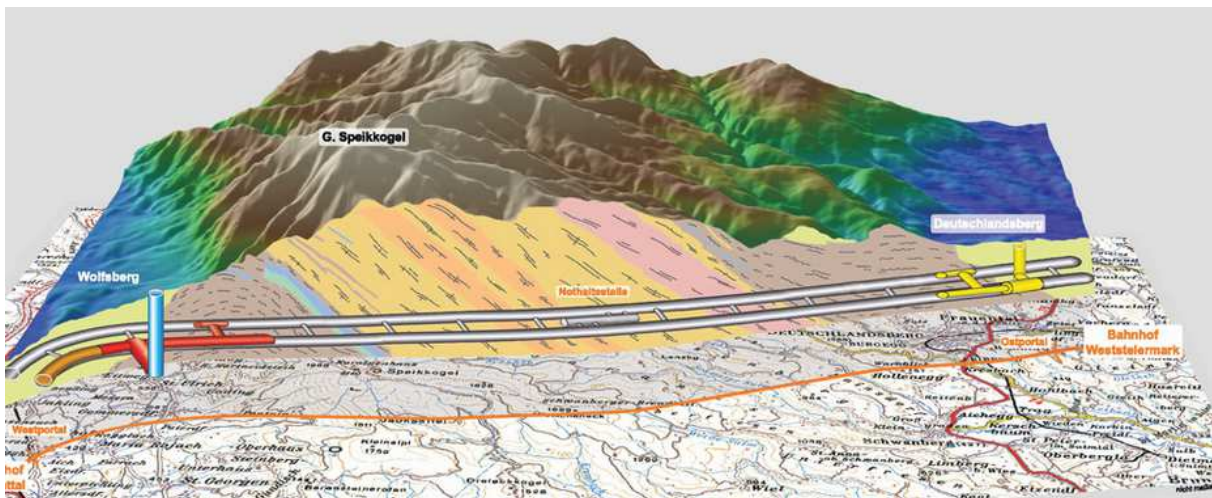

Figure 2.8 3-D Model of the Koralm tunnel (ÖBB Infrastruktur AG)

## 2.2.2. Road Tunnels

The fact is that in Mexico there is not railway system for passengers except the touristic corridor Topolobampo-Chihuahua in the north of Mexico and Guadalajara-Tequila in the west of the country (Ferrocarril Mexicano). Hence is obviously that the SFT proposed in this work is destined for roadway use.

Therefore, the road tunnel study is basically for the work. In addition must be studied the safety considerations and innovative proposals for become road tunnels safer. The most relevant road tunnels which special considerations during their design step are listen here below.

### a. Laerdal tunnel

With 24.5 km is the longest road tunnel in the world (until 2013). The tunnel carries two lanes of European Route E16 and represents the final link on the new main highway connecting Oslo and Bergen via Aurland, to Laerdal and over Filefjell, in Norway.



Due to the great length of the tunnel special considerations were done in its design. One of the most challenges was for drivers not to find the trip "boring and monotonous", thereby losing concentration during the 20-minute journey. So a group of psychologists from the Industrial and Technological Research Association (SINTEF) worked together with the Norwegian Public Roads Administration (NPRA). The task was to make the journey through the tunnel a pleasant experience for most people. The creation of a degree of variation during the car journey will reduce the risk of the driver losing concentration and becoming "speed blind".

The research results give rise to the following points:

- Gentle curves and short straight sections will make driving through the Laerdal tunnel less monotonous, without breaching the guidelines for safe viewing distance.
- At any given point in the tunnel, the safe viewing distance will be 1000 meters or more.
- The tunnel is divided into four sections, separated by three large mountain caves at 6-kilometre intervals. While the main tunnel has white lights, the caves have blue lighting with yellow lights at the fringes to give an impression of sunrise (Figure 2.9). The caves are meant to break the routine, providing a refreshing view and allowing drivers to take a short rest (Brekke, 2010).

The caverns are also used as turnaround points and for break areas to help lift claustrophobia during a 20-minute drive through the tunnel. To keep drivers from being inattentive or falling asleep, each lane is supplied with a loud rumble strip toward the center (Brekke, 2010).

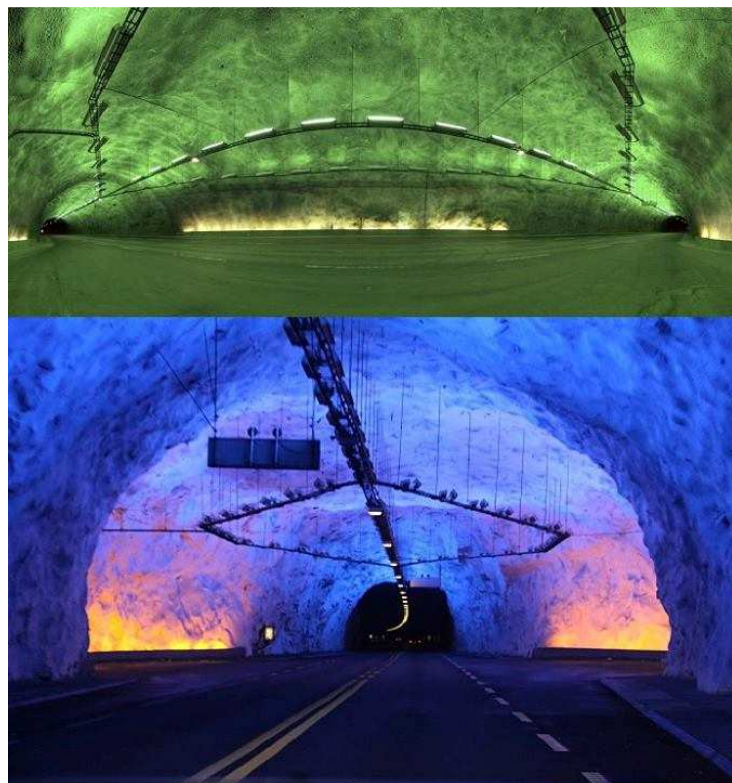

*Figure 2.9 Parking caves in Laerdal Tunnel (Flickr)*

In the emergency point of view, the tunnel is equipped with:

- SOS-marked emergency telephones every 250 meters which can contact the police, fire departments, and hospitals.
- Fire extinguishers equipment every 125 meters.
- 15 turning points for busses and articulated lorries.

- Signs with the text "Turn and drive out" will be illuminated when the turning points are to be used.
- Every 6 kilometers the turnings points are built as a large rock chambers.
- Small lay-bys for breakdowns every 500 meters.
- Separate emergency channels for the police, fire service and medical services.
- Computer links to the emergency service in Laerdal or Bergen.
- Aerial system for P1 radioGSM mobile telephone link.
- Counting and photo system monitors all traffic in and out the tunnel.
- Equipment for monitoring and checking the ventilation systems, radio connections, lightning systems, traffic lights, emergency equipment, removal of extinguishers, air quality, ventilations system an any accident inside the tunnel.

High air quality in the tunnel is achieved in two ways: ventilation and purification. Large fans draw air in from both entrances, and polluted air is expelled through the ventilation tunnel to Tynjadalen. The Laerdal Tunnel is the first in the world to be equipped with an air treatment plant, located in a 100-metre (330 ft) wide cavern about 9.5 kilometers northwest of Aurlandsvangen. The plant removes both dust and nitrogen dioxide from the tunnel air. Two large fans draw air through the treatment plant, where dust and soot are removed by an electrostatic filter. Then the air is drawn through a large carbon filter which removes the nitrogen dioxide (Brekke, 2010).

#### b. Zhongnanshan Tunnel

Is the longest two-tube road tunnel in the world and the second longest road tunnel overall in the world after the Laerdal single-tube tunnel in Norway. The 2 x 18.04km-long Zhongnanshan tunnel is on the Xi'an-Ankang highway, which is part of a national highway linking Baotou in Inner Mongolia in North China to Beihai in Guangxi Zhuang autonomous region in South China.

Each tube has two road lanes with a geometry of 6-m high and 10.92-m wide. The distance between the centre lines of the two bores is 30 m. In addition there are three ventilation shafts along the tunnel. In this project are employed caverns similar to laerdal tunnel in order to break the monotony. These are place at intervals of three to seven kilometers.

The lighting design of the tunnel is the main characteristic which has taken the worldwide attention in tunnel engineering. As it was designed the three caverns for the laerdal tunnel, in this project were taken similar considerations for lighting design in order to avoid monotony along the journey. The main point was to obtain a good distribution of light, in conjunction with the use of artistic lighting, which turns out to give drivers a feeling of space and of greater security. Modern lighting systems, with two rows of lamps, light sources that illuminate the opposite direction and driving lane were employed. Thereby, the tunnel was then developed in collaboration with Norwegian artists (from the laerdal tunnel) into an oasis with palm-trees and clouds on the roof (Jenssen, 2010). In Figure 2.10 can be appreciate the lane decoration of the tunnel.



Figure 2.10 Interior design of the Zhongnanshan Tunnel (China.org.cn)

c. St. Gotthard

The St. Gotthard road tunnel in Switzerland with 16.9 km is the third-longest road tunnel in the world. It forms runs from Göschenen in the Canton of Uri at its northern portal and Airolo in Ticino to the south part. The St. Gotthard tunnel forms part of the A2 motorway in Switzerland, running south from Basel through the tunnel down to Chiasso on the border with Italy.

Some statistics of the St. Gotthard Tunnel are (swissinfo.ch):

- Dimensions: 4.5 m high; 7.80 m width
- Maximum velocity allow: 80 km/h
- Emergency exits: every 250m, giving access to the parallel safety passage.
- Lighting: 14,000 fluorescent lights
- Ventilation: 23 ventilators and air vents every 90m
- Video surveillance: 86 cameras
- Traffic: 3 million vehicles in 1980, over 6.2 million in 2010 (of which about 945,000 were trucks)

From 1980-2000, the St Gotthard Road Tunnel was the longest in the world. At the time, both the structural design and the provision of safety and ventilation systems were very advanced.

On October 24, 2001, a collision of two trucks created a fire in the tunnel, killing eleven and injuring many more, the smoke and gases produced by the fires being the main cause of death. So then, it was renovated and rehabilitated the equipment and safety, mainly the ventilation system. It was introduced at opening ventilation grills, which can extract high concentrations of exhaust fumes, while limiting the spread of smoke. The new system operates as follows:

- Under normal operating conditions the extraction of exhaust fumes is distributed by the grills partially open.
- In the event of fire all the grills close, except those in the fire zone, which are fully open. The schemed of this solution is shown in the Figure 2.11.

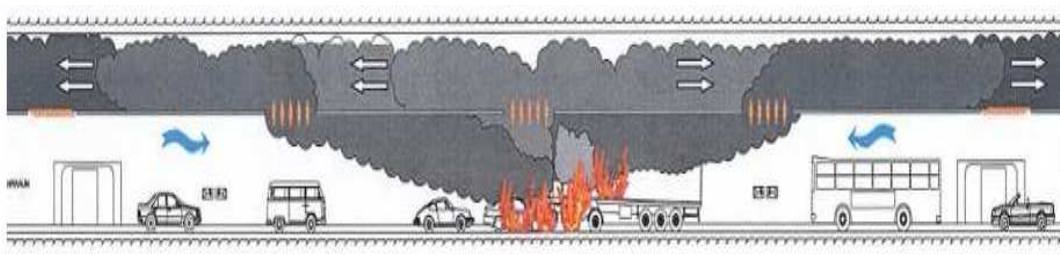

Figure 2.11 Scheme of the new ventilation system in the St. Gotthard tunnel (Lombardi engineering LTD.)



d. Mont Blanc

The Mont Blanc road Tunnel is one of the major trans-alpine routes. It runs under the Mont Blanc Mountain, linking Chamonix, Haute-Savoie in France and Courmayeur, Aosta Valley in Italy. The single tube tunnel has a total length of 11.6 km with 8.6 m width and 4.35 m high.

The tunnel was opened in 1965 and since then it has continued receiving updates throughout its existence, both in terms of technology and safety. Lamentably, on 24 March, 1999, a devastating fire took place in the tunnel where lamentably 39 people died. The tunnel was shut for three years and since then it became in a starting point for meeting strict safety requirements for tunnels around the world.

The main measures added for the tunnel safety are:

- Three command posts. The main one is located on the French side, one at the centre and the other at the Italian end.
- Fire-resistant sheeting fitted to its walls. More traffic lights and flashing warning signs have been added as well.
- Concrete lined emergency shelters, in total 37 placed at intervals of 300 meters. Each is pressurized and fitted with fireproof doors and a video link to one of three command posts.
- A total of 116 smoke extractors fitted one every 100 meters. In addition 76 new fresh air vents have been created.
- Heat sensors at both ends of the tunnel to detect overheated trucks before they enter the tunnel (Figure 2.12).
- 120 video cameras will monitor traffic at all times.
- A fire station in the middle of the tunnel complete with double cabbed fire trucks.
- 10 radar speed control units and 10 radar safety distance control units.
- 36 emergency parking areas.
- 4 water tanks with a capacity of 120 m<sup>3</sup> each with one conduit conveying water under pressure
- 12 FM radio frequencies that can be received inside the tunnel, broadcasting safety messages in three languages
- 1 thermometric cable equipped with 3,860 sensors
- 2 barriers at the entrances. In addition 40 half-barriers each associated with a variable message panel and a red traffic light.



Figure 2.12 Thermographic inspection stations in Mont Blanc Tunnel (Kristoferb, 2011)

In Figure 2.13 can be appreciated the schemed of the modernization in the Mont Blanc Tunnel. As was detailed described before, the rehabilitation consisted in equipping the infrastructure with high quality systems. The Tunnel has Centralized Technical Management (CTM), a computer system that checks and keeps the tunnel under constant surveillance along its entire length and processes data coming from over 35,000 control points. It is able to detect any anomaly and suggest to the operator the scenario that will allow him to use the appropriate road signs, adjust the ventilation, inform users (FM radio, variable message boards), give the alarm to emergency teams and give the alarm to and communicate with outside intervention teams (TMB GEIE).

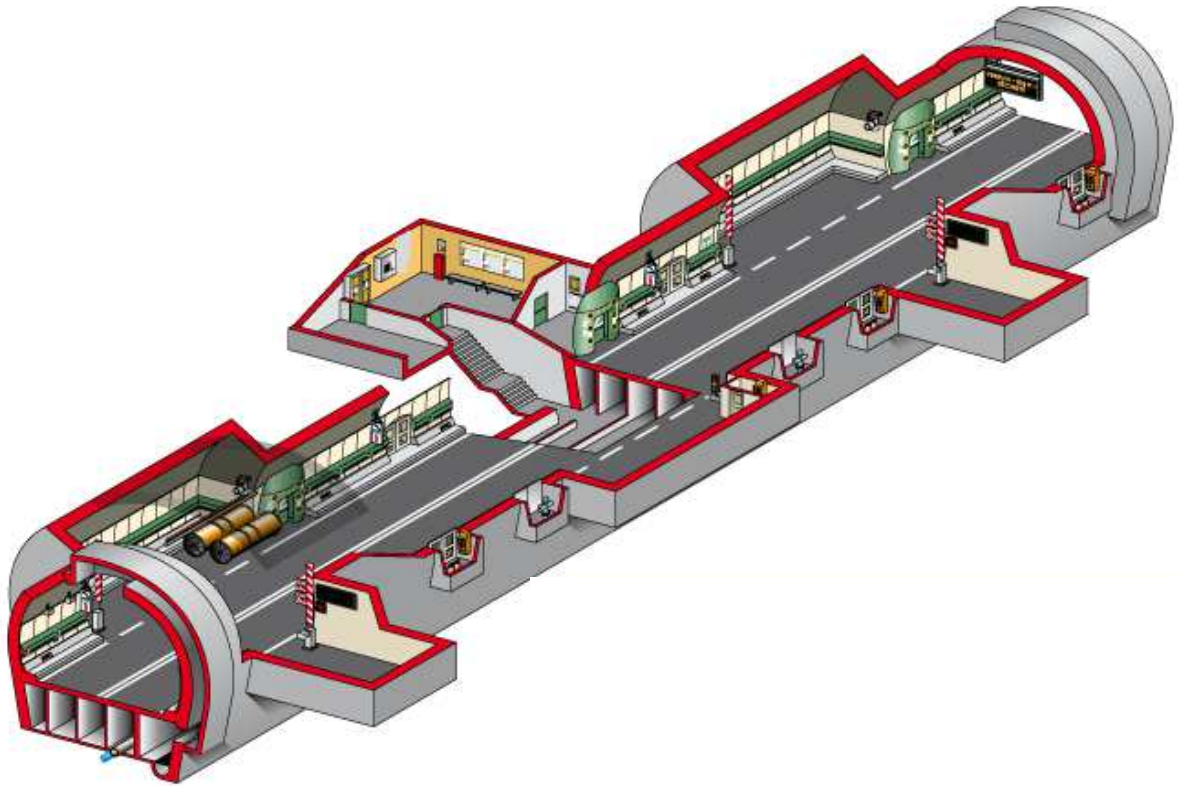

*Figure 2.13 Drawing of the equipment in the Mont Blanc Tunnel (TMB GEIE)*

Detailed drawings of the equipment can be consulted in:  
[www.tunnelmb.net/v3.0/gb/equipement\\_gb.asp](http://www.tunnelmb.net/v3.0/gb/equipement_gb.asp)

e. Rogfast

Rogfast is the name of a 25.5 km long subsea tunnel being planned to pass under Boknafjord in Rogaland, Norway. The tunnel will contribute to reduce the journey time on the Coastal Highway Route E39 between Stavanger and Bergen. Construction is expected to start in 2016, with completion scheduled in 2023. After its completion will break the record of the World's longest road tunnel (as well as subsea road tunnel) and World's deepest road tunnel (at 395 m).

The tunnel is planned as twin tunnels with cross-sections of T10.5. The arm up to Kvitsøy is planned as one tunnel. The line location is designed according to design class S9, i.e. with a design speed of 100 km/hr. Due to the length, an attempt to break the monotony will be made by placing large horizontal curves between 3,800 m and 20,000 m (Espedal, 2013). Longitudinal ventilation is adopted as main system due the piston effect from

traffic pushing air along the tunnel as long as there is one-way traffic. Additionally three double shafts have been chosen located on the golf course at Tungenes on the mainland in the south, on Kvitsøy and on Kråka Island near Arsvågen in the north. This provides a simple, flexible ventilation facility that can be developed as the traffic increases (Figure 2.14).

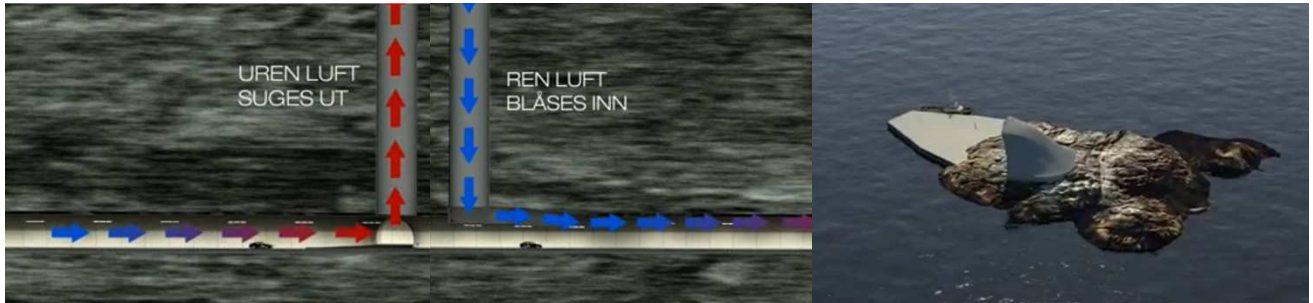

Figure 2.14 Concept of the double shaft at Kråka Island (NPRA)

As project during the planning step, some safety measures evaluated in the preliminary design of the tunnel are (In Figure 2.15 can be appreciated the scheme of these measures):

- Emergency exits every 125 m when the gradient is 5% or more.
- Cross tunnels every 1250-1500 m along the tunnel.
- Emergency lane when the gradient exceeds 5% in order to provide the heaviest vehicles with their own climbing lane.
- Emergency lay-bys in the tunnel separate at 500 m.
- Drivable cross connections for use in problem situations such as traffic accidents and maintenance.
- Driving in long tunnels can lead to tiredness, inattention and anxiety. Measures that will be evaluated are varying the cross section through the tunnel to help break the spatial monotony to which road users are exposed: use of light, marking of special points etc.
- The effectiveness of an active extinguishing system is evaluated (deluge, sprinkler, water mist).
- The effect of a separate parking space for hazardous goods and emergency vehicles will be evaluated with respect to fire/emergency services. In addition, the possibility of a separate road traffic centre for tunnels in the area and an operations building for fire/-emergency rescue services at the tunnel entrance must be evaluated.



Figure 2.15 Render of the rogfast tunnel (NPRA)

f. Trans-Tokyo Bay Highway

The Trans-Tokyo Bay Highway, also known as the Tokyo Bay Aqualine, is a 15.1 km marine crossing through the middle of Tokyo Bay connecting Kawasaki City in Kanagawa Prefecture with Kisarazu City in Chiba Prefecture on the Boso Peninsular. It is one of the largest marine projects in Asia, formed by 9.5 km undersea tunnel connected to 4.4 km bridge (Figure 2.16).

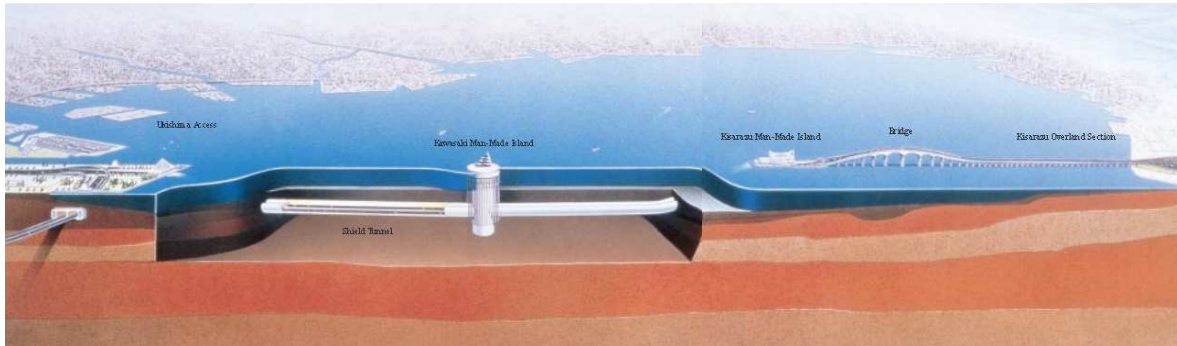

Figure 2.16 Tokyo Bay Aqualine sketch (Kajima, 1997)

The Tokyo Wan Aqua-line also includes two artificial islands. The Kisarazu Island where the tunnel joins the bridge has a dimension of 650m long and 100m wide and includes ventilation towers as well as a parking area (Figure 2.17a). Moreover, The Kawasaki artificial Island midway along the undersea tunnel which has a diameter of approximately 200 m which also incorporates ventilation towers (Figure 2.17b).



Figure 2.17 Artificial islands in the Tokyo Bay Aquiline: (a) The Kisarazu Island joins the subsea tunnel and the bridge; (b) The Kawasaki artificial Island works as ventilation towers. (dvice.com & findery.com)

### 2.2.3. Immersed Tunnels

More than a hundred immersed tunnels have been built worldwide to provide road or rail connections. It is a well known technique that has been used in many countries with some significant variations. The most important different issues according the design are the materials and cross section employed. In America the most common practice is employed steel pipes with some concrete as ballast propose. Whereas in Europe the traditional solution is employed rectangular cross section made of concrete. In addition, in Asia composite materials have been employed for the fabrication of the elements.

The history of immersed tunnels for transportation started in 1910 with the construction of a two track railway tunnel under the Detroit River between the USA and Canada. On the other hand, the first concrete tunnel in Europe was the Maastunnel at Rotterdam in the Netherlands, built between 1937 and 1942.



A fact is that the IMT technology has been improved in many aspects of the design and construction. Thus many projects have been placed in offshore as well as severe environmental conditions. Construction period and great lengths of the projects is the most notorious improvement in the IMT field.

In the following are presented the most important Immersed Tunnel projects realized around the world.

a. Oresund

The Oresund tunnel is an IMT of 3.5 km which runs under the Drogden Channel. It is part of the Oresund Link, which is a tunnel and bridge connection between Denmark and Sweden (Figure 2.18). This 16.7 km long link is a direct traffic and train connection between Copenhagen and Malmo. The transition between the tunnel and the bridge is accommodated by a large artificial island approx 4 km long.



Figure 2.18 Aerial view of the Oresund Link (De Wit et al., 2012)

The tunnel is divided into 20 elements, each 176m long; each element is made up of 8 segments of 22m each. The tunnel includes two railway tubes, two roadway tubes and an escape gallery. The outer dimensions of the cross section are 8.5m by 41.7 m. The cross section designed is shown in the Figure 2.19.

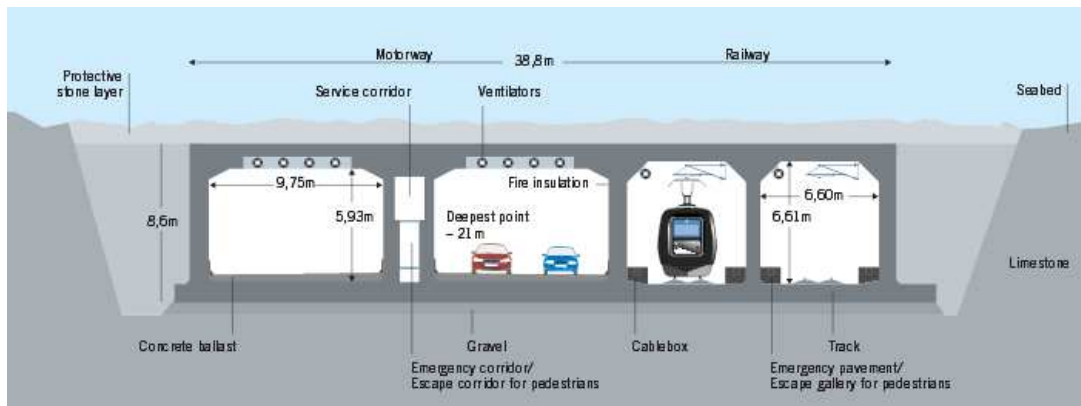

Figure 2.19 Cross section of Oresund Tunnel (Fermen, 2006)

The motorway tubes have two 3.5m wide lanes without a hard shoulder, but with a one meter wide emergency pavement on a level with the road's asphalt surface.

New Jersey safety barriers protect the lower part of the walls, which are clad with washable aluminum panels. Every 88m, there are 1.2m wide emergency doors from the road tunnels to the escape corridor.

The rail tubes have elevated emergency pavements on both sides and emergency doors every 88m. Rescue crews have access from the southern motorway tube to the northern rail tube every 88m.

All tube ceilings, and the top of the walls, are covered with fire insulation (Fendolite) designed to withstand a fire impact of 1,350°C for two hours (femern, 2006).

The main safety features of the Oresund Tunnel are:

- Lighting

The motorway tubes have longitudinal light bands on both sides with increased light strength near the tunnel entrances. The light bands can be regulated in accordance with the external level of light. Near the ramps, the motorway is covered by lamella which reduces the black hole effect. Inside the rail tunnels there are light ramps which can be switched on by the Traffic Controller as required. In both the motorway and the rail tunnels, emergency lighting has been installed in case normal lighting fails.

- Fire protection

At every emergency exit in the motorway tubes, panels have been installed, which contain fire valves with pressurized water linked to two 230 m<sup>3</sup> water reservoirs at the portal buildings. On the opposite wall, there are emergency panels with a fire alarm, an emergency telephone and a 6kg powder extinguisher. Emergency telephones and fire alarm have also been installed in both rail tubes alongside the emergency doors between the two rail tunnel tubes. Each emergency door and emergency panel is marked by an illuminated sign.

- Fire Fighting Protection System

An automatic water mist system has been installed in the technical area between the two motorway tunnels. There are also gas extinguishing systems in the technical room in the portal buildings at Peberholm and Kastrup and at the deepest point of the tunnel. In the pump sumps in the portal buildings and at the motorway tunnel's deepest point, there are foam extinguisher systems.

- Ventilation

Each motorway tube contains 80 ventilators in four groups. Each group comprises 20 ventilators in five rows with four ventilators in each row. In each rail tube, there are 20 ventilators in four groups with five in each group. The main function of the ventilation system is to eliminate smoke and heat in the event of fire and maintain clean air in the tunnel in all situations. Sensors for carbon monoxide, nitrogen dioxide and visibility have been installed at four locations in each motorway tube. The ventilation system is automatically controlled via the SCADA system or from the Traffic Centre at Lernacken.

- CCTV

The road tunnel has an advanced traffic control system which, via cameras installed at 60m intervals, allows the Traffic Centre at Lernacken to monitor the traffic flow and to automatically detect queues and stationary vehicles. Variable information signs allow for speed to be adjusted in the tunnel, for lanes to be blocked and for traffic to be directed to the other lane. At the two ramps, barriers can stop traffic entirely or reroute traffic to the other motorway tube.

- Communication

There are no loudspeakers in the tunnel, but the Traffic Centre uses three FM channels to communicate with motorists. The radio frequencies, which motorists are advised to tune into during their passage through the tunnel, are indicated on signs before the tunnel.

- Restrictions

Under normal circumstances, the maximum speed in the road tunnel is 90km/hour. HGVs are not allowed to overtake in the tunnel. The transport of hazardous freight is only permitted between the hours of 11 pm and 6 am and explosives can only be transported up to 1 ton per wagon or vehicle at a time

b. HongKong Zhuhai Macao Bridge (HZMB)

The HZMB immersed tunnel is currently under construction and with 6 km long it will become in one of the longest IMT in the world. It forms part of the HZMB Link of a29.6 km, crossing the Pearl River Estuary from the border with Hong Kong to Macao and Zhuhai (Mainland China). The Link comprises various bridges, artificial islands and tunnels.

The tunnel accommodates three lanes in each direction with speed limit of 100 km/h. The cross section has a dimension of 37.95 m wide and 11.50 m height. In addition between the two tubes a space of 4.25 m is provided. It accommodates emergency passage, drainage system, electrical conducts and an especial space for smoke extraction during fire events (Figure 2.20).

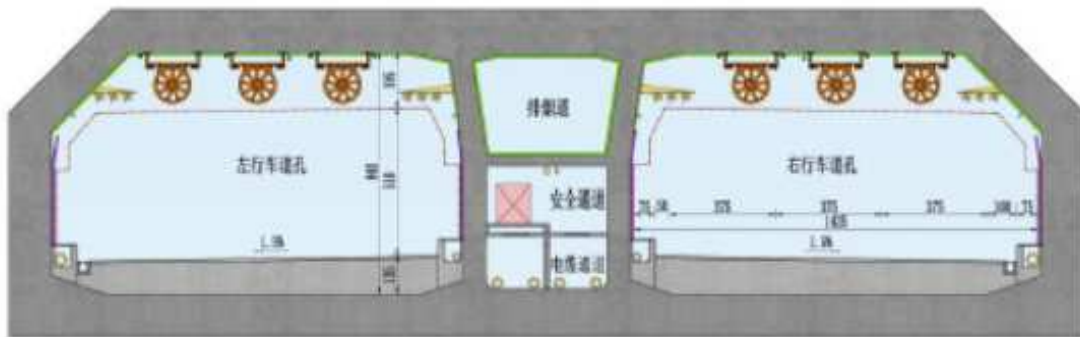

Figure 2.20 HZMB cross section (De Wit et al., 2012)

Due to the length of the tunnel many safety aspect must be touched. Safety is best served by having as few accidents as possible. But since prevention cannot be perfect, adequate response to incidents and accidents is equally important. Upon occurrence of an accident / incident, the drivers and passengers should be able to move away from the accident spot to a safe environment as quickly as possible. Emergency services must have optimal access to the tunnel and accident / incident location to help control or preferably terminate the accident and if required to rescue victims. Traffic must be immediately prevented from entering the tunnel, in order to limit the number of cars and people involved in the accident/incident, and to make sure that the routes of egress and access can be used safely (Su et al., 2012).

The safety concepts of the HZMB tunnel include these implementations:

- Jet-fan induced longitudinal tunnel ventilation
- Independent smoke extract ventilation
- Foam-mist fire extinguishing system or sprinkler system
- Escape doors from each of the two traffic tubes to the emergency escape tube at intervals of 90m
- Traffic information system
- Emergency power supply
- Emergency lighting
- Emergency escape guiding

- Accident communication
- Structural passive fire protection systems
- A tunnel monitoring and fire alarm system which receives and processes alarm signals, including automatic alarm signals from special fire detector (linear temperature-sensing detector), and manual alarm buttons located in the tunnel.

The ventilation system of the tunnel operates by these conditions:

- In the operation phase it works with longitudinal ventilation with jet fans supported by natural ventilation induced by the piston effect and enhanced by the traffic.
- In case of a fire a parallel smoke extraction system will be activated using a semi transverse ventilation system including a separate smoke extraction cell (located above the escape cell) combined with an additional system like foam mist fire extinguishing system or a sprinkler system.

In the Figure 2.21 can be appreciate the ventilation concept of the tunnel.

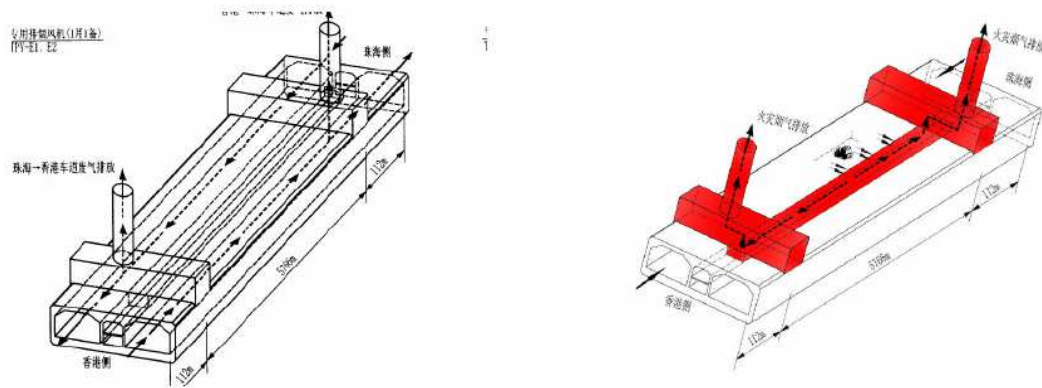

Figure 2.21 Ventilation concept for the HZMB tunnel (Su et al. 2012)

### c. Busan Geoje

The Busan Geoje immersed tunnel is one of the longest (3.2 km) and deepest (maximum water depth of 48 m) in the world. It forms part of a Fixed Link which connects the south eastern city of Busan and Geoje Island in South Korea. The IMT consist in 18 tunnel elements with a length of 180m The standard tunnel elements E1 to E16 have exterior dimensions of 26.46m width and 9.97m height. The widths of element 17 to 18 increased to 28.46m because of climbing lane. These tunnel elements are prefabricated of reinforced concrete in a temporary dry dock and are towed to the site and lowered into final position in a dredged trench and are placed on a screeded gravel bed directly without temporary support. The typical cross section is shown in Figure 2.22.

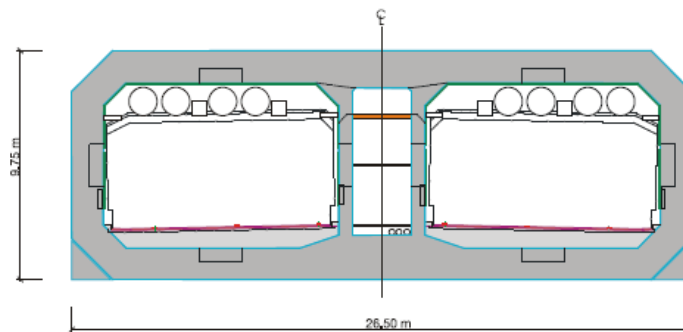

Figure 2.22 Cross section of the Busan Geoje immersed tunnel (Kim)



#### d. Fehmarn Belt

This is the most ambitious project in the Immersed Tunnel technique. It consists in an 18 km tunnel which after its completion it will become the longest IMT in the world for more than twice to its predecessor. It is part of the Fehmarn Belt Fixed Link that is proposed to connect the German island of Fehmarn with the Danish island of Lolland crossing the Baltic Sea.

The Conceptual Design envisages an IMT consisting of 79 standard elements with identical shape and layout these standard elements is approximately 216 m long, 42 m wide and 9 m high. The elements consist of 9 segments, 24 m long separated by contraction joints with a rubber-metal water-stop. In addition to the standard elements, the immersed tunnel will have a total of 10 special elements that are installed at regular intervals (approximately every 1.8 km) between the standard elements. Each of these special elements is 39 m long, 47 m wide and 13 m high (Pedersen et al., 2013). In Figures 2.23 are shown the both cross section proposed.

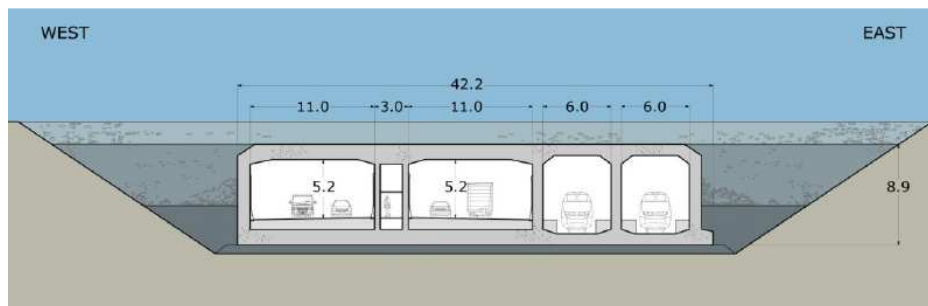

The tunnel contains two road tubes, two rail tubes, and a central gallery, which is divided into three levels. The lower level houses the drainage pipes and water supply lines for hydrants and the fire protection system. The middle level is at the same height as the road and can be used both for maintenance personnel as well as a safety zone. The upper level is a service gallery where electrical panels are placed and utility lines run from the special elements to the operating systems in the tunnel.

Due the great length of the IMT, the safety issues are most strictly than others similar crossing solutions. Thus, the safety considerations have been divided in different levels. The primary safety objective for safety level 1 is to provide a tunnel solution that will prevent accidents and other emergency situations occurring. It has been achieved through both design and operational considerations, these includes:

- Unidirectional tunnels either road and rails, thus no head-on collisions would be presented
- Multiple tubes for escape, rescue and fire fighting set-up
- Central gallery for safety
- Robust concrete structure

- High reliability and availability of protection systems (Traffic information system / Drivers awareness lighting)
- Fire separated systems – services and pipe gallery
- Road and rail control rooms (24/7)

In order to minimized the impact of an incident the issues are taken in the security level 2. For the self rescue principle these include amongst others:

- Exit doors at 108m intervals, highly visible
- Initial road evacuation into central gallery, protected area
- Walkways and exits in rail tunnels
- Voice alarms, radio rebroadcast
- Exit signage, distance to exits signs
- Electronic messaging
- Safety and emergency lighting
- Emergency stations every 54m with portable extinguishers
- Tunnel roof and walls with passive fire protection system– RWS hydrocarbon curve.
- Automatic suppression water deluge system
- Longitudinal Ventilation System
- Pressurized central gallery
- Uninterruptable and backup power supply
- Drainage in all tubes for capture of dangerous goods
- Range of emergency communication systems – FM radio, mobile phones, emergency telephones, TETRA radio system
- Hydrant systems every 50 m with a capacity of 1200l/min
- Access to tunnels at portals for first response and brigade vehicles
- Fire systems controls at portals
- Dedicated control rooms (two plus auxiliary)
- Comprehensive fire and emergency response plan

Another innovative solution for the longest IMT takes in account the driver's perception and comfort. It consists in moving light images as well as a system of colored light portals. The images to be projected on the tunnel walls and the light portals shall help maintain driver awareness and interest and develop a sense of progression through the tunnel during the 10 minute journey (Pedersen et al., 2013). The Figure 2.24 illustrates the solution of moving images in the tunnel walls.



Figure 2.24 Interior design of the IMT Fehmarn Belt (Femern)

e. Marmaray

Is a rail transport project in Istanbul, Turkey. It consists in an undersea rail tunnel under the Bosphorus strait which links the city of Halkalı on the European side and Gebze on the Asian side. The project includes an immersed tunnel which is the deepest in the world at 58m under the water surface. The IMT has a total length of 1.4 km assembled from 11 sections, eight are 135 meters, two are 98.5 meters and one element is 110 meters long.

After the experience in fatal accidents like Mont Blanc or Channel Tunnel many considerations for this project were done. The purpose of the design related to safety is to ensure that:

- Passengers that are capable of rescuing themselves can escape to a place of refuge.
- Rescue of those passengers not capable of rescuing themselves is possible and can be initiated immediately
- Passengers and staff can be evacuated
- Access is available to emergency services
- Normal operation can quickly be resumed

The main safety implementations for the Marmaray IMT are:

- Emergency exits every 125 m.
- Longitudinal Ventilation based on fans with reversible option ( “push-push” and “push-pull”)
- Fire hose cabinet at least every 45 m.
- Special vehicles for the purpose of rescuing in fire events.
- The Fire Protection System consists on sprayed mortar thickness approximately 40 mm on the walls and slab.
- Fire detection system of Detection systems for control of air quality. These detection systems will as a minimum provide control of temperature, CO and NOx.
- Flood gates in order to flooding inside the IMT. In addition are space routes for people to flee when the gates have been closed.
- The drainage sumps and the equipment in such sumps shall be capable of handling up to 50 m<sup>3</sup> of hydrocarbon spillage and shall be explosion proof (100 kN/m<sup>2</sup>)

### 2.3 Design Requirements

A reality is that the task of a tunnel is crossing an obstacle, either a mountain or a water crossing. Once that a tunnel is chosen as crossing solution the design of the proposal starts. In the point of view of the writer, the safety of drivers in tunnels is the most important issue that has to be taking in account during the design stage. A fact is that tunnels nowadays are safer than open roads. Thus, the accidents and incidents in the tunnels are less frequent than in open roads, however, the consequences on the enclosed structures are potentially hazardous than in the open ones.

Thereby, some requirements are established for meet the safety conditions in tunnels. Mainly the countries that have many tunnels are created regulations and have developed recommendations and guidelines for the design, construction, operation, maintenance, safety and the intervention of the rescue services.

### 2.3.1 Codes around the world

Around the world are many regulations for the design of tunnels. Many countries have adopted this practice as solution for their road network and a lot of experience has been earned since this practice started. On the other hand, many countries do not have any regulations relating to tunnels and to tunnel safety, because they do not have road tunnels within their territory. It is recommended that these countries choose a complete and coherent package of the existing regulations of a country with lengthy experience in the field of tunnels, and not to multiply the origins of the documents by dipping into different sources (PIRACY).

The following countries are considered the main "road-tunnel-countries" in Europe, with the highest traffic volume in tunnels: Italy, France, Switzerland, Germany, Norway, and Austria in the order of annual vehicle kilometers in tunnels according the European Thematic Network Fire in Tunnels (ETNFT). In addition, USA, China and Japan are representative countries which have adopted the tunnels as solution for crossing obstacles in their road networks.

On the other hand, concerning safety conditions in road tunnels, countries belonging to the European Union are subjected to Directive 2004/54/CE that prescribes a minimum level of arrangements to be implemented in order to ensure the safety of users in tunnels longer than 500 m that are part of the trans-European road network. A wider group of European countries are also bound by an international convention, The European Agreement concerning the International Carriage of Dangerous Goods by Road (ADR) and includes specific arrangements for tunnels. Every member country has transposed these European regulations to its own national legislation. Some member countries have implemented additional regulations that are more demanding than the one that results from the transposition of the European regulation.

In the table 2.1 are summarized the regulations, guidelines, standards, and recommendations of the different countries consulted. Some of them are taken from English translation of other works and referenced here directly in this language.

Country/ Organization	Title	Reference	Year
Italy	▪ Circular 6 Dec. 1999. Safety of Traffic in Road Tunnels with Particular Reference to Vehicles Transporting Dangerous Materials.	Circ.06.12.1999	1999
	▪ Functional and geometrical standard for construction of roads.	Norm 05.11.2001	2001
	▪ Light and lighting Tunnel lighting	UNI 29000240	2003
France	▪ Inter-ministerial circular n°2000-63 of 25 August 2000 concerning safety in the tunnels of National road network.	Circ2000-63A2	2000
	▪ Inter-ministerial circular n°2000-82 of 30 November 2000 concerning the regulation of traffic with dangerous goods in road tunnels of the national network.	Circ2000-82N2	2000
	▪ Law n° 2002-3 of 3 January 2002 relative to safety of infrastructures and transport systems.	Law2002-J2	2002
	▪ Risk studies for road tunnels : Guide to methodology	ESD	2002
Switzerland	▪ Guidelines for the Design of Road Tunnels. ASTRA (Swiss Federal Roads Office).	ASTRA Road Tunnels	1995
	▪ Ventilation of Road Tunnels, Selection of System, Design and operation. Project. ASTRA (Swiss Federal Roads Office)	ASTRA Ventilation	2004
Germany	▪ RABT Guidelines for equipment and operation of road tunnels. (Road and Transportation Research Association).	RABT 02	2002
	▪ ZTV Additional Technical Conditions for the Construction of Road Tunnels - Part 1 Closed Construction	ZTV - Tunnel	1995

	- Part 2 Open Construction		1999
Austria	<ul style="list-style-type: none"> <li>▪ Guidelines and Regulations for Road Construction:</li> <li>- Tunnel cross section</li> <li>-Structures</li> <li>-Interior Construction</li> <li>-Ventilation Fundamentals</li> <li>-Ventilation, Calculation of fresh air demand</li> <li>-Lighting</li> <li>-Operational and safety measures, Structure</li> <li>-Operational and safety measures, Equipment</li> <li>-Operational and safety measures, Radio equipment</li> <li>-Maintenance of tunnel equipment</li> </ul>	RVS ref: 9.232 9.233 9.234 9.261 9.262 9.27 9.281 9.282 9.286 13.74	1994 1987 2001 1997 1997 1991 2002 2002 1987 1999
Norway	<ul style="list-style-type: none"> <li>▪ Roads Tunnels Public Roads Administration</li> </ul>	Manual 021	2004
United Kingdom	<ul style="list-style-type: none"> <li>▪ Design manual for roads and bridges</li> </ul>	BD 78/99	1999
Netherlands	<ul style="list-style-type: none"> <li>▪ Technical standards for the provisions and installations:</li> <li>-Ventilation of Road Tunnels</li> <li>-Safety Guidelines Part C / Basic measures for Safety in Tunnels</li> <li>-Fire Protection for Tunnels</li> </ul>	- VRC safety GT-98036	1991 2004 1999
Sweden	<ul style="list-style-type: none"> <li>▪ Tunnel 2004 Swedish National Road Administration</li> </ul>	VV Publ. 2004:124	2004
USA	<ul style="list-style-type: none"> <li>▪ Standard for road tunnels, bridges and other limited access highways</li> </ul>	NFPA 502	2001
Japan	<ul style="list-style-type: none"> <li>▪ State of the Road Tunnel Equipment Technology in Japan</li> </ul>	PWRI 061	1993
European Union	<ul style="list-style-type: none"> <li>▪ Directive 2004/54/EC of the European Parliament and of the Council of 29 April 2004 on minimum safety requirements for tunnels in the trans-European road network</li> </ul>	Directive 2004/54/EC	2004
PIRACY World Road Association	<ul style="list-style-type: none"> <li>▪ Road Tunnels Manual</li> </ul>	-	2011

Table 2.1 Manuals and guidelines referenced of road-tunnel-countries (ETNFT)

### 2.3.2. Cross-Section geometry

The dimensions of the shapes employed are dependent on the dimensions of the cross section necessary for traffic. These vary due to:

- Traffic volumes and the destination of use of the tunnel
- Design speeds, safe stopping distances and sight distances
- Space for in-tunnel equipment such as: signs, traffic and environment monitoring
- Cost of the facility balanced against the required safety standards
- The traffic management required to respond to an incident in the tunnel
- The usual local norms and the financial possibilities.

The main shapes employed as cross section for road tunnels are shown in the Chart 2.26

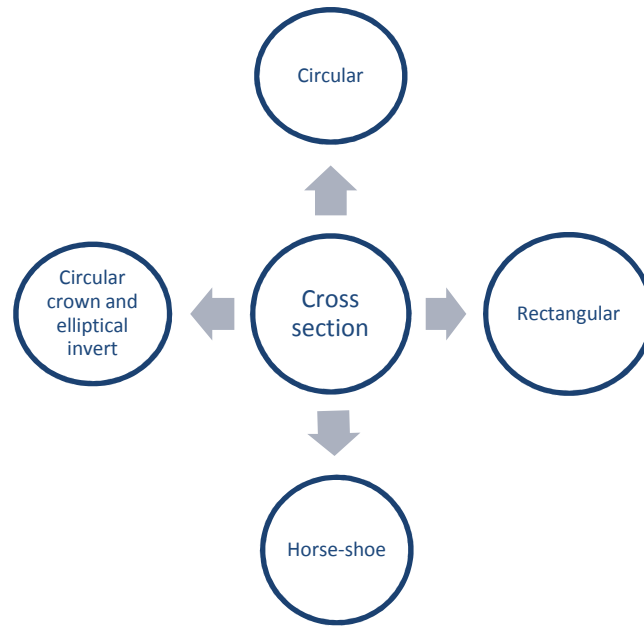

*Figure 2.26 Typical cross section employed in road tunnels*

In addition to the cross section shape the tunnels can be unidirectional or bidirectional depending the circulation of the traffic in one single tube. A fact is that bidirectional tunnels cause more accidents than unidirectional ones. Nevertheless users observe fairly well the prohibition to overtake in tunnels with average longitudinal gradients. In case of steep gradients it should be adequate, however, to plan an additional lane for heavy vehicles. It is strongly advised against changing the traffic direction to absorb daily traffic peaks (PIRACY). For easiness the design of the cross section it is purpose to realized in the following four steps:

- I. Selecting the suitable shape of the tunnel. Depending the fabrication method and spaces for accommodate the required installations. Circular or rectangular shapes are recommendable for precast tunnels.
- II. Dimensioning the carriageway of the tunnel. It comprises the area inside the inner edges of the outermost traffic lane markings and the off carriageway. Common dimensions are shown in Table 2.3.
- III. Dimensioning the off carriageway of the tunnel. They are those areas in plan outside the carriageway, including edge lane markings, clearances, emergency lanes, sidewalks and safety barriers. Common dimensions are shown in Table 2.4 and 2.5.
- IV. Dimensioning the vertical clearance of the tunnel. Including the maintained headroom and clearance for fixtures such as detection equipment, fans, signs, etc. Common dimensions are shown in Table 2.6.

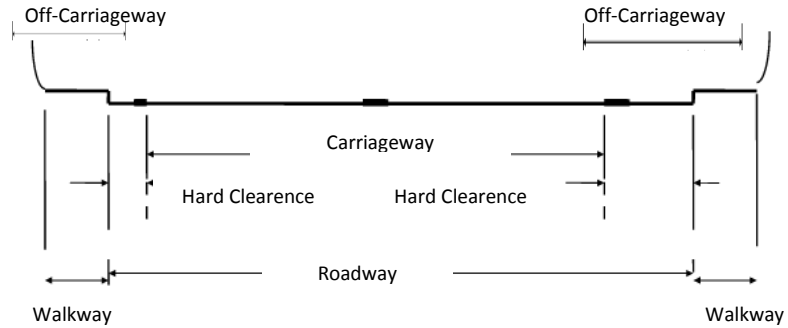

Figure 2.27 Components of the roadway in the cross section

As it is known, the Immersed Tunnels are fabricated with circular or rectangular cross section. Due to the easiness of the fabrication point of view, this shape can be adopted for the Submerged Floating Tunnel. In addition, the hydrodynamic actions can be decreased with the rounded shapes.

A fact is that the rectangular and circular cross-sections are the most common employed for precast tunnels and have been adopted in some feasible studies of SFTs. Thus the inner geometry of the components is study in this section. In the Figure 2.28 are presented the features of the different cross section for both cross-section shapes.

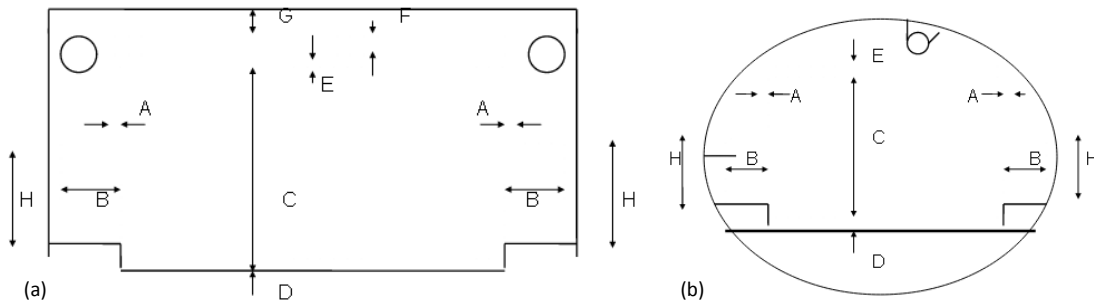

Figure 2.28 Components of the Cross section: (a) Rectangular; (b) Circular (PIRACY)

ID	Component
A	Lateral Clearance between the edges of the roadway and fixtures such as detection equipment, fans, signs etc.
B	Walkway
C	Maintained Headroom
D	Additional Allowance to provide for road resurfacing
E	Vertical Clearance between the Maintained Headroom and fixtures such as detection equipment, fans, signs etc
F	Allowance due to construction of the room
G	Vertical Clearance for fixtures such as detection equipment, fans, signs etc
H	Walkway Headroom

Table 2.2 Cross section component description (PIRACY)

The width of traffic lanes and carriageways vary in many countries according their codes. Sometimes these widths are dependent on the design speed or the reference speed. In Table 2.3 are shown some values of carriageway width.

Country and name of guidelines or other source	Design Speed or Reference Speed [km/h]	Width of Traffic Lane [m]	Width of Traffic Lane Marking [m]	Width of Carriageway [m]
Austria RVS 9.232 [10]	80 - 100	3.50	0.15	7.00
Denmark (practice)	90 - 120	3.60	0.10	7.20
France CETU [11]	80 - 100	3.50	?	7.00
Germany RAS-Q 1996 [12]/ RABT 94 [13]	100(26T,26Tr) 70 (26t) 110 (29.5T)	3.50 3.50 3.75	0.15 0.15 0.15	7.00 7.00 7.50
Japan Road Structure Ordinance [14]	80 - 120 60	3.50 3.25		7.00 6.50
the Netherlands ROA [15]	120 90	3.50 3.25	0.15 0.15	7.00 6.50
Norway Design Guide Road Tunnels [16]	80 - 100	3.45	0.10	6.90
Spain Instrucción 3.1 [17]	90 - 120	3.50	0.10	7.00
Sweden Tunnel 99 [18]	70 90 110	3.50 3.75 3.75	0.10 or 0.15 0.15 0.15	7.00 7.50 7.50
Switzerland (rectangular tunnels)	80 - 120	3.50 - 3.75	0.20	7.75
Switzerland (SN 640201) [19]	80 - 120	3.50 - 3.75	0.20	- 7.75
UK TD27(DMRB 6.1.2) [20]	110	3.65	0.10	7.30
USA AASHTO [21]		3.60	n.s.	7.20

n.s. = not specified  
(same symbology)

Table 2.3 Carriageway dimensions (PIRACY)

On the other hand, the off-carriageways comprise the hard clearances and the walkways. The main difference in the hard clearances adjacent to driving and overtaking lanes is that “usually” the hard clearance adjacent to the driving lane is wider since broken down vehicles are parked on or adjacent to this lane. On roads of the motorway type in the open air usually an emergency lane is provided. Hard clearances in tunnels are often restricted for economic reasons. This restriction can make it impossible for broken down vehicles to park on the hard clearance adjacent to the driving lane without occupying part of the driving lane and thus disrupting traffic flow (PIRACY). For these reason, are presented two tables with different hard clearance of the adjacent driving lane. One for tunnels where it is impossible for motorists to park their vehicles on the carriageway without interfering with normal traffic (Table 2.4) and one for tunnels where this is possible (Table 2.5).

Country and name of guidelines or other source	Design Speed [km/h] (profile nr)	Width of hard clearance [m]	Width of walkway [m] or safety barrier (sb)	Width of off-carriageway [m]
Austria RVS 9.232	80 - 100	> 0.25	1.00	> 1.25
Denmark (practice)	90 - 120	0.50	1.00	1.50
France CETU	80 - 100	1.00 0.30 <sup>#</sup>	0.75	1.75 1.05 <sup>#</sup>
Germany RABT 94/RAS-Q 1996	70-100 (26 t) 70- 100 (26Tr)	0.25 1.75 <sup>#</sup>	1.00 1.00	1.25 2.75 <sup>#</sup>
Japan Road Structure Ordinance	80 - 120 60 - 80	1.00 0.75	0.50 0.25	1.50 1.00
the Netherlands ROA	120 90	1.50 (0.80) 1.00 (0.50)	sb sb sb	1.50 + sb (0.80) + sb 1.00 + sb (0.50) + sb
Norway Design Guide Road Tunnels	80 - 100	0.30	0.75** 1.25***	1.05 1.55***
Spain Instrucción 3.1	90 - 120	1.00	0.75	1.75
Sweden Tunnel 99	70 90 110	2.00 2.00 2.75	sb sb sb	2.00 + sb 2.00 + sb 2.75 + sb
Switzerland	80 - 120	-	1.00	1.00
UK TD27(DMRB 6.1.2)	110	1.00	0.70	1.70
USA AASHTO	n.s.	0 - 1.50	0.50 - 0.70	0.50 - 2.20

Table 2.4 Off-carriageway dimensions without parking lane (PIRACY)



Country and name of guidelines or other source	Design Speed [km/h] (prof.nr)	Width of hard clearance [m]	Width of walkway [m] or safety barrier	Width of Off-carriageway [m]
Austria RVS 9.232	80 - 100			
Denmark (practice)	90 - 120	3.00	1.00	4.00
France CETU	100	2.00	sb	2.00 + sb
Germany RABT'94/RAS-Q 1996	100 (26T) 110 (29,5T) #	2.50 3.25#	1.00 1.00	3.50 4.25#
Japan Road Structure Ordinance	80 - 120		-	2.50
the Netherlands ROA	120 90	3.95 3.95	sb sb	3.95+ sb 3.95+ sb
Norway Design Guide Road Tunnels	80 - 100	no emergency lanes		no emergency lanes
Spain Instruction 3.1	90 - 120	2.50	0.75	3.25
Sweden Tunnel 99	70 90 110	2.00 2.00 2.75	sb sb sb	2.00+ sb 2.00+ sb 2.75+ sb
Switzerland (rectangular tunnels)	80 - 120	3.00	1.00	4.00
Switzerland (oval tunnels)	80 - 120	no emergency lanes		no emergency lanes
UK TD27(DMRB 6.1.2)	110 (urban m.w.)	3.30 2.00	0.70 (0.10 + 0.60)	4.00 2.70
USA AASHTO	n.s.	3.00	0.70	3.70

Table 2.5 Off-carriageway dimensions with emergency lane (PIRACY)

Finally the design of the vertical clearance is dimensioned. This comprises the minimum headroom above the carriageways which is at least equal to the maximum design height of heavy good vehicles (HGV) that is allowed on the road. It must consider a space necessary to allow for rocking movements of the vehicles due to irregularities of the pavement and the vehicle. Furthermore, it must comprised the enough space for fixing the installations required for the operating of the tunnel, such as fans, luminaries, signs and so on.

In Table 2.6 are shown the vertical clearance allowed for tunnels in the different countries. The letters C, E, G, D and F are referred to Figure 2.28.

Country and name of guidelines or other source	Minimum Headroom above Carriageway (m)	Maintained Headroom C above Carriageway (m)	Additional allowance E as safety zone for signs, luminaries, fans etc. [m]	Allowance G for signs, luminaries, fans etc. [m]	Allowances D and F for later pavement and construction [m]
Austria RVS 9.232		4.70	n.s.	min. 0.20	n.s.
Denmark (practice)	n.s.	4.60	0.20	n.s.	n.s.
France CETU		4.50 (roads in international network) 4.75 (highest order roads)	0.10	n.s.	0.05 - 0.10
Germany RAS-Q1996/RABT 94	4.20	4.50	n.s.	n.s.	n.s.
Japan Road Structure Ordinance		4.50	n.s.	n.s.	n.s.
the Netherlands ROA	4.20	4.50	0.20	0.30	n.s.
Norway Design Guide Road Tunnels	n.s.	4.60	0.10	n.s.	0.10
Spain Instruction 3.1		5.00			
Sweden Tunnel 99		4.50	0.20	0.40	
Switzerland (rectangular tunnels)	n.s.	4.50	0.20	0.40	
Switzerland (oval tunnels)	n.s.	4.50			
UK TD27(DMRB 6.1.2)	5.10	5.35	0.25	0.40	n.s.
USA AASHTO	n.s.	4.90 (free ways) (other highways)	n.s.	n.s.	n.s.

Table 2.6 Headroom dimension of different countries (PIRACY)

### 2.3.3 Structural measures

#### 2.3.3.1 Emergency exit for users

The emergency exits for tunnel users are established with the purpose of having a safe place in case of fire or any emergency inside the tunnel. The exits will mainly be used in connection with a fire in the tunnel. The emergency exits can be connected to the adjacent traffic tube, to a dedicated escape tube or out to the open air. The connection can be direct or through a cross passage, shaft or similar. In some cases shelters are arranged as safe havens, where tunnel users can stay for some time while the rescue team arrives to the incident place. In the table 2.7 is summarized the requirements for the different design codes.

Country/ Organization	Requirements			
	Parallel escape tube	Emergency cross-passage	Shelter	Direct pedestrian emergency exit
<b>France</b>	Just if this is justified for technical reasons	Every 200 m; in non urban areas every 400 m when the tunnel exceeds 500 m	Mandatory when no parallel escape tube or emergency cross passage are applied	Where the roadway is less than 15 m from the ground surface
<b>Switzerland</b>	no reference	For pedestrian every 300 m, for vehicles every 900 m	No reference	No reference
<b>Germany</b>	Geometry specification in case of existing	When tunnels $\geq 400$ m must at regular distances $\leq 300$ m	No reference	The escape doors can connect directly to the open or to evacuation shafts
<b>Austria</b>	Could be used to minimize the escape routes	For Pedestrian at 250 m; for vehicles at 1000 m	No reference	Consult: RVS 9.281
<b>Norway</b>	no reference	Every 250 m	No reference	No reference
<b>United Kingdom</b>	Should be considered on a whole life cost basis	Positioned at 100m intervals	It shall be examined and established by the Design Organization from first principles	The escape passage can lead to the exit
<b>Netherlands</b>	Geometry specification in case of existing.	No reference	No reference	Geometrical specification in case of applying
<b>USA</b>	Walkways shall be continuous the entire length of the tunnel, terminating at surface grade	Not be farther than 200 m	Openings in cross passageways shall be protected with self-closing fire door assemblies having a minimum of a 1-hour rating	Emergency exits shall be provided throughout the tunnel and spaced so that the travel distance to an emergency exit shall not be greater than 300 m
<b>EU</b>	Possible solution. Placed at not more than 500 m	Possible solution. Placed at not more than 500 m	Possible solution. Placed at not more than 500 m	Possible solution. Placed at not more than 500 m

Table 2.7 Structural measures for emergency exits for users

#### 2.3.3.2 Emergency access for rescue staff

In case of an emergency as fire or a severe accident, the rescue personnel may not be able to access inside directly through an adjacent tunnel or through shafts. The access from an adjacent tunnel may allow emergency vehicles to move from tunnel to tunnel, or access may be for rescuers on foot only.

Country/ Organization	Requirements					
	Separate emergency vehicular access gallery	Cross passage vehicular access	Emergency lane	Direct pedestrian access (lateral, upstairs, shaft)	Turning areas	Emergency Services station at portals
<b>France</b>	In tunnel more than 5 km long, the emergency exits capable of motor-driven	Every 800 m in tunnels longer than 1000 m	When the traffic is in one way	Geometry specification in case of use	Every 800 m in tunnels longer than 1000 m	Shall be provide an area of 12mx3m for parking emergency vehicles
<b>Switzerland</b>	No reference	No reference	Emergency bays every 600-900 m In bidirectional tunnels longer than 1.5 km, alternating on each side every 2-3 km	No reference	In bidirectional traffic tunnels > 1.5 km every 2-3 km turning bays	No reference
<b>Germany</b>	Reasonable when are consider evacuation tunnels	Every third cross passage can be designed for vehicles	To be evaluated. Lay-bys at ≤ 600 m	No reference	Considered at ≤ 600m	No reference
<b>Austria</b>	Could be used to minimize the ways for rescue staff.	Every 500 m	To be evaluated. Lay-bys every 1000 m	No reference	Every 4000 m	No reference
<b>Norway</b>	No reference	No reference	No reference	No reference	Every 1000, 1500 or 2000 m depending the type of tunnel	No reference
<b>United Kingdom</b>	No reference	No reference	No common	No reference	In tunnels longer than 5 km, not more than 1 km from the middle of the tunnel	Analyze if it is necessary
<b>Netherlands</b>	No reference	No reference	No reference	Ideal to support the rescue team	No reference	No reference
<b>USA</b>	No reference	No reference	No reference	No reference	No reference	The command post shall be located at a site that is convenient for responding
<b>EU</b>	When is geographically possible	Cross-connections suitable for the use of emergency services shall be provided at least every 1500 m	Lay-bys shall be provided at distances which do not exceed 1000 meters, if emergency lanes are not provided	No reference	No reference	No reference

Table 2.8 Structural measures for emergency access for rescue staff

### 2.3.3.3 Drainage of flammable liquids

If flammable liquids are spilled in a tunnel there is a risk that the spill can be ignited and cause a serious fire. If the tunnel is well drained and the flammable liquids are collected in a system suitable for the purpose, this risk can be reduced.

Country/ Organization	Requirements			
	Inclination of tunnel axis	Separate drainage systems	Liquid sump	Non porous surface course
<b>France</b>	Minimum transverse gradient of 2%; a continuous slot gutter is compulsory capacity of 5m <sup>3</sup> /min	No reference	System capable of 200 m <sup>3</sup> (40 m <sup>3</sup> for hazardous liquids and 160 m <sup>3</sup> of water for controlling the accident	prohibited within tunnels more than 50 m from the ends
<b>Switzerland</b>	No reference	In tunnels with high frequency of hazard goods	No reference	No reference
<b>Germany</b>	A slotted channel with a drain capacity of 100 l/s is	As far as possible	For accidental cases the volume must be approximately 100m <sup>3</sup> (72 m <sup>3</sup> for fire extinction and approximately 30 m <sup>3</sup> spill from a tank	No reference
<b>Austria</b>	Inclination should be 0.5%; draining in a length of 200m tunnel an amount of 200l/sec	No reference	the drainage system should be designed to take care of environmentally dangerous waste.	No reference
<b>Norway</b>	maximum longitudinal gradient 6 - 8%	Shall be established; a sand trap shall be located every 80 m	Pumps system, pump sump, sludge interceptor and oil separator.	chosen in accordance with Handbook 018 (open roads)
<b>United Kingdom</b>	Transverse gradient of 2.5%	No reference	Should be designed. It can be assumed a volume of 30 m <sup>3</sup>	Porous asphalts are unsuitable as they may retain flammable or toxic spillages arising from an incident.
<b>Netherlands</b>	traverse gradient of 2%	No reference	The target value for collection of liquid in the nadir sumps is 30 m <sup>3</sup> . For the main sump the target value is 240 m <sup>3</sup>	No recommended
<b>USA</b>	No reference	The drainage collection system shall be designed so that spills of hazardous or flammable liquids cannot propagate along the length of the tunnel. The components shall be noncombustible	The collection system shall drain to a storage tank or transfer pumping station of sufficient capacity to receive, as a minimum, the simultaneous rate of flow from two fire hoses without causing flooding on the roadway.	No reference
<b>EU</b>	Longitudinal gradients above 5 % shall not be permitted in new tunnels, unless no other solution is geographically possible. In tunnels with gradients higher than 3%, additional and/or	Where the transport of dangerous goods is permitted, the drainage of flammable and toxic liquids shall be provided for through well-designed slot gutters or other measures within the tunnel cross	The drainage system shall be designed and maintained to prevent fire and flammable and toxic liquids from spreading inside tubes and between tubes.	No reference

	reinforced measures shall be taken to enhance safety on the basis of a risk analysis.	sections.		
--	---	-----------	--	--

Table 2.9 Structural measures for drainage of flammable liquids

## 2.3.4 Safety equipment

### 2.3.4.1. Ventilation

Ventilation of smoke is a very important safety measure either for the evacuation of tunnel users and for assistance to the fire fighting operation. The arrangement of the ventilation system may be dependent on the traffic (contraflow or unidirectional traffic) the traffic and the length of the tunnel.

Country/ Organization	Requirements			
	Natural ventilation by shafts	Longitudinal	Transverse	Ventilation control sensors
<b>France</b>	Acceptable for tunnels shorter than 300 m in urban tunnels or 500 m in non urban tunnels	Unidirectional non urban tunnel: up to 5000 m; Unidirectional urban tunnel: up to 500 m; Bidirectional non urban tunnel: up to 1000 m; Bidirectional urban tunnel: prohibited	Smoke extraction must be capable of being achieved over a distance of the order of 400 m in an urban tunnel and 600 m in a non-urban tunnel If fresh air blower blocks are more than 800 m long	must ensure that for users a pollution level of 150 ppm of carbon monoxide and an absorption coefficient per unit length, K, of 9.10-3 m-1 is not exceeded at any point in the tunnel following an accidental traffic stoppage
<b>Switzerland</b>	Sufficient in bidirectional tunnels ≤ 200 m; for unidirectional must be calculated	Decision and Calculation based on guidelines	Decision and Calculation based on guidelines	In each ventilation-section CO concentration and opacity have to be measured
<b>Germany</b>	Acceptable in tunnels shorter than 400 m	Evaluation for tunnels longer than 600 m	Used in case of long tunnels.	The opacity must be measured along the tunnel in distances of maximum 300 m. Closure of the tunnel is necessary, when the CO concentration of 200 ppm, or an extinction coefficient of 12 ·10-3 m-1 is exceeded.
<b>Austria</b>	Permitted if the fresh air demand during normal operation is ensured and the length of the escape routes is within the limits.	Decision and Calculation based on guidelines	Decision and Calculation based on guidelines	In each ventilation section the following should be measured: CO concentration (2x), Opacity (2x), Air speed and direction, Air volume and air pressure difference (transversal and semi-transversal ventilation), Traffic parameters
<b>Norway</b>	Acceptable in tunnels shorter than 250 m	In long tunnels with heavy traffic, or where there are particular restrictions	No reference	The detectors shall be installed for measuring the level of CO and NO gas in the middle of the tunnel and at each end

<b>United Kingdom</b>	Acceptable in tunnels shorter than 300 m	For tunnels between 300 and 400 m length, after analyzed it.	Fully transverse ventilation is the most comprehensive form of mechanical ventilation, but because of its high capital and operational costs, is seldom adopted for new tunnels.	Anemometer, ultrasonic flow or orifice plate devices shall be installed in the tunnel to give a reading of the tunnel air direction and velocity to the control room.
<b>Netherlands</b>	Acceptable in tunnels shorter than 250 m	Longitudinal ventilation is suitable for unidirectional tunnels > 250 m.	Recommendable in tunnels with high volume of traffic	Detection of CO every 500 m.
<b>USA</b>	Acceptable in tunnels shorter than 240 m	Longitudinal ventilation acceptable for unidirectional tunnels > 240 m.	Required in bidirectional tunnels or unidirectional with extraction points	No reference
<b>EU</b>	Allowed in tunnels shorter than 1000m	Allowed in tunnels with bidirectional and/or congested unidirectional traffic after a risk analysis according article 13	When it is not allowed the longitudinal ventilation.	No reference

Table 2.10 Safety equipment of ventilation

#### 2.3.4.2. Lighting

In case of an emergency it is important to have sufficient lighting in the tunnel. The light will provide visibility for a possible evacuation and for any rescue/emergency operation. In case of a fire, additional marker lights may indicate the route to the exits. Also in the escape routes (cross passages, escape tunnel etc.) it will be necessary to have sufficient light in order to facilitate evacuation.

Country/ Organization	Requirements		
	Emergency tunnel lighting	Marker light in tunnel	Emergency exit and rescue access lighting
<b>France</b>	over the roadway and walkways of an average of 10 lux, and 2 lux at any point	Located at a height of approximately 1 m approximately every 10 m along the sidewalls.	It will ensure a minimum average lighting level of 10 lux and 2 lux at all points when these facilities are in use.
<b>Switzerland</b>	Normal lighting is used as emergency lighting (see power supply)	No reference	No reference
<b>Germany</b>	The normal tunnel lighting is also used as emergency lighting.	No reference	No reference
<b>Austria</b>	Emergency lighting equals the lowest category of normal lighting	Self lighting signs at the boundary of the driving lanes a=3m-25m	On the escape routes a permanent switched on lighting for orientation including direction markings has to be installed
<b>Norway</b>	Priority lighting is arranged by ensuring that every 4th or 5th luminary works in approximately 1 hour after the power fails.	No reference	The lighting should be installed every 62.5 m on one side of the tunnel approximately 1.0m above the road surface providing 1800 lumen
<b>United Kingdom</b>	One luminary in ten of the Stage 1 lighting shall be designated as emergency lighting and maintained by a UPS.	No reference	No reference
<b>Netherlands</b>	Lighting installations are	At 1.5 m above the road	Level of illumination in escape

	designed in separate sections to prevent power failure in the entire lighting systems as result of an emergency.	surface, recommended on the wall at the emergency exits.	routes must have a minimum 100 lux on the floor. Green LED-lighting on top and on both sides of an emergency exit to indicate the location of the exit
<b>USA</b>	The emergency lighting system shall be arranged to provide the required illumination automatically in the event of any interruption of normal lighting due to any of the following	Emergency fixtures, exit lights, and signs shall be wired separately from emergency distribution panels	The illumination levels of tunnel roadways, walkways, and walking surfaces shall not be less than 3 lx at the walking surface
<b>EU</b>	Safety lighting shall be provided to allow a minimum visibility for tunnel users to evacuate the tunnel in their vehicles in the event of a breakdown of the power supply	Evacuation lighting, such as evacuation marker lights, at a height of no more than 1.5 meters, shall be provided to guide tunnel users to evacuate the tunnel on foot, in the event of emergency	Required for evacuation in case of emergency

*Table 2.11 Safety equipment of lighting*

#### 2.3.4.3. Signage

There will be many types of sign in a road tunnel. The signage will partly have a preventive purpose (e.g. speed limits, restrictions on overtaking, etc.), partly it will inform the tunnel users about the occurrence of an emergency situation and give information about what to do in response to the situation and assist in its control. In the present study, focus is given to the mitigation measures, i.e. the second function of the signage. Some signs may be of benefit both for prevention and mitigation, e.g. information about the radio channel; these signs will also be included in the comparison.

Country/ Organization	Requirements		
	Traffic signs and signals outside the tunnel	Traffic signs and signals inside the tunnel	Exit pedestrian signs
<b>France</b>	No reference	Signage for emergency facilities, stopping traffic at entrance and every 800 m.	Signs or permanently illuminated signs shall be provided to draw the attention of users to the safety facilities available
<b>Switzerland</b>	Starting from 1000 m outside the tunnel and 500 for bidirectional tunnels	3 colored signals (red, yellow, and green) every 300 m. Placed at cross passages and emergency call stations.	No reference
<b>Germany</b>	Minimum equipment for all tunnels: Indication of height for all tunnels < 4,50 m; Warning sign traffic lights; Speed limit; Overtake restriction; Lights on/off; Traffic signal red /yellow at portal; Variable traffic sign for explanation of closure;	No traffic lights inside the tunnel. Permanent traffic lights (open lane/closed lane) each 300 - 600 m.	Escape routes are identified by Escape symbol and arrow symbols per escape direction with indication of the distance to the nearest exit or portal, permanent light (15W).
<b>Austria</b>	At each portal	At lay by and cross passage for vehicles- One light signal at each emergency telephone station	Lighted signs above or beside the doors
<b>Norway</b>	The following road signs are appropriate in front of tunnels: Warning sign: Tunnel, Information sign: Tunnel name, Restriction sign: Height limit. Overtaking prohibited, Prohibited access for pedestrians	Inside the tunnel Information sign: radio station, SOS telephone, Distance to tunnel openings. Red stop signal at turning points	At cross passages and other escape routes inside the tunnel an internally lighted green and white sign

	and cyclists, information sign: Radio station. SOS telephone and fire extinguisher		
<b>United Kingdom</b>	All tunnels shall be equipped with portal/lane controls signals to enforce closures.	Portal/lane controls signals, capable of displaying lane closed cross (red), lane open arrow (green) and blank (wigwag), shall be provided where it is necessary to separately control traffic in each running lane	At each emergency point within the tunnel it is desirable to include the distance to the nearest emergency exit in each direction.
<b>Netherlands</b>	For the purpose of lane diminishing inside the tunnel it is necessary place traffic signals outside the tunnel to warn the traffic about the changed situation inside the tunnel.	For emergency facilities	Every 25 m (in between emergency exit doors) signs on the same wall must indicate the different distances to the emergency exit do
<b>USA</b>	For status of the tunnel (Direct approaches to the tunnel shall be closed following activation of a fire alarm within the tunnel)	Recommended an incident commander for emergency situations	Lighting shall be provided to highlight special emergency features including but not limited to fire alarm boxes, extinguishers and telephones, and special feature instructional signage.
<b>EU</b>	The following sign shall be put at each entrance of the tunnel: Sign E11A for Road Tunnels of the Vienna Convention; the length, the Name, the radio station (in case), variable message signs (tunnels longer than 100m)	In tunnels longer than 3000m with a control centre and a traffic volume higher than 2000 vehicles per lane, equipment to stop vehicles in case of an emergency is recommended at intervals not exceeding 1000 m.	The signs to indicate Emergency exits should be G signs according to the Vienna Convention. It is also necessary to sign the two nearest exits on the sidewalls.

Table 2.12 Safety equipment of signage

#### 2.3.4.4. Communication and alarm systems

The communication can be in terms of automated systems triggered by equipment monitoring air quality or specifically for incident detection. In addition, such triggering can be manual by alarm push button or by emergency telephone. Redundancy in the detection systems is necessary in order to achieve a high probability of triggering the appropriate response to an emergency situation / fire.

Furthermore, communication systems can be used to instruct the affected tunnel users about what to do in the situation. This information may be given via radio or information signage while the users are still in their vehicles, or through the emergency telephone or, in some cases, through loud speakers for users in the tunnel or in emergency shelters.

Country/ Organization	Requirements						
	Emergency telephone	Alarm push button (manual fire alarm)	Automatic alarm on equipments (exit doors, extinguisher, fire boxes)	Automatic incident detection system (AIDS)	Fire/smoke detection (ventilation sensors or specific fire detection)	Radio rebroadcast	Loudspeakers (in tunnel, in shelters)
<b>France</b>	Every 200 m	Optional	Automatic alarm on shelter door opening and extinguisher removal	Obligatory	Required when there is not human supervision	Required for tunnels longer than 800 m	Shelters must be provide with loudspeakers
<b>Switzerland</b>	In	Just in	No reference	No reference	Automatic	No reference	No reference



	bidirectional tunnel every 150 m alternating on each side; unidirectional every 300 m	tunnels with high traffic frequency			fire detection system which reacts to the degree of temperature. Obligatory when exist mechanical ventilation. At $\leq 300$ m		
<b>Germany</b>	Placed at regular distance $\leq 150$ m in tunnels $\geq 400$ m long	In tunnels longer than 400 m	Automatic alarm by opening the door to the emergency call station	No reference	Obligatory in tunnels longer than 400 m with mechanical ventilation	Minimum one FM band radio station with traffic radio service (RDS, in future DAB) shall be broadcasted in the tunnel	Required in tunnels monitored by video. Either along the tunnel as the portals
<b>Austria</b>	Every 250 m in tunnels $\geq 500$ m long	Two push buttons (SOS, fire) at each emergency telephone station	Automatic alarm by opening door of extinguishers	No reference	Automatic fire detectors in operation rooms and lay bys. Along the tunnel in mechanical ventilation	Tunnels from 1km to 2.5 km it is recommended, for tunnels over 2.5 km length special measures are recommended	At portal, lay by and turning area
<b>Norway</b>	Between 250m and 500 m according the tunnel type	No reference	Automatic alarm when a extinguisher is removed	It shall be analyzed in the early phase of project	No reference	Required in tunnels longer than 500 m	No reference
<b>United Kingdom</b>	Every 100 m	Fire alarm facility either manual or automatic every 50 m	Automatic alarm in all the emergency facilities	The need for CCTV Alert shall be discussed	Fire detection mentioned for sumps and service buildings.	According the tunnel type	No reference
<b>Netherlands</b>	In each emergency exit	No reference	Automatic alarm by opening emergency door	Required in tunnels with high traffic intensity and in tunnels without additional emergency lanes inside the tunnel.	In tunnels with mechanical ventilation	High Frequency (HF) system when standard radio reception inside the tunnel is poor	In the exit routes
<b>USA</b>	No reference	Alarm boxes shall be installed at intervals of not more than 90 m and at all cross passages and means of egress from the	No reference	No reference	The fire detection system shall be installed in tunnels where 24-hour supervision is not provided, capable of identifying	No reference	No reference

		tunnel			the location of the fire within 15 m		
<b>EU</b>	Placed in emergency stations. In new tunnels located every 150 m; for in existing tunnels at not more than 250m	No reference	No reference	Video monitoring systems and a system able to automatically detect traffic incidents (such as stopping vehicles) and/or fires shall be installed in all tunnels with a control centre.	Automatic fire detection systems shall be installed in all tunnels, which do not have a control centre	Radio rebroadcasting shall be installed in all tunnels longer than 1000m with a traffic volume higher than 2000 vehicles per lane	Optional in the tunnel. In shelters and other facilities where users must wait, it shall be equipped with loudspeakers for receive indications

Table 2.13 Safety equipment of Communication and alarm systems

#### 2.3.4.5. Traffic regulation - monitoring equipment

Traffic regulation and monitoring is mainly a preventive measure. However, monitoring the traffic, its speed and density, as well as monitoring unwanted events, accidents and fires directly, will provide information to the tunnel operator. On the basis of this information the tunnel operator can take actions to mitigate the consequences of the accident or fire.

Country/ Organization	Requirements			
	Monitoring of traffic speed and density	Closed circuit television (CCTV)	Remote control barriers	Thermographic portal detectors (trucks)
<b>France</b>	No reference	Required	Needed in tunnels longer than 800 m	Recommended
<b>Switzerland</b>	Traffic counting devices are necessary in tunnels with non natural ventilation	No reference	No reference	Recommended
<b>Germany</b>	Traffic data recording shall be carried out in the tunnel with a distance of 300 m.	Required in tunnels with length $\geq 400$ m, with traffic $\geq 4000$ HGV $\times$ km/bore per day and with underground junctions. Cameras Placed 75-150 m	The barriers shall be arranged in accordance to the local conditions and recommendations of the rescue forces	No reference
<b>Austria</b>	Monitoring of number of vehicles, speed, traffic jam at the portals and every 1000m	Additional video monitoring at the portals and every 200m-300m	No reference	No reference
<b>Norway</b>	Include in the AIDS	Required in tunnels with a high utilization of the capacity during a large part of the day	The needed shall be investigated	No reference
<b>United Kingdom</b>	Recommended	Required in some tunnel types.	No reference	No reference
<b>Netherlands</b>	Needed in high frequency tunnels and in tunnels with additional emergency	Needed in tunnels with traffic detection by operators	No reference	No reference

	lanes inside the tunnel.			
<b>USA</b>	No reference	CCTV with or without traffic-flow indication devices shall be permitted to identify fires in tunnels with 24-hour supervision	Road tunnels longer than 240 m (800 ft) shall be provided with means to stop traffic from entering the direct approaches to the tunnel	No reference
<b>EU</b>	No reference	It shall be installed in all tunnels with a control centre.	Optional in tunnels longer than 1000 m. In tunnels longer than 3000m placed at intervals of 1000 m	No reference

*Table 2.14 Safety equipment of traffic regulation*

#### 2.3.4.6. Fire Fighting System

The objective is to reduce the consequences of a fire event. Many solutions are available and also system usually employed in buildings can be adopted. In addition the experience of previous fire accidents has led to fortify the measures against fires event minimizing the impact either for users as the tunnel structure.

Country/ Organization	Requirements		
	First aid manual fire fighting	Fire fighting media	Fixed fire suppression system (Sprinkler, Deluge)
<b>France</b>	Two portable extinguisher of 6kg located at emergency exits	Hydrant delivering 120 m <sup>3</sup> at a pressure of 0.6 MPa are to be installed approximately every 200 m.	No reference
<b>Switzerland</b>	Two portable extinguisher of 6kg located every 150 kg in bidirectional tunnels alternated each side. Every 300 m in unidirectional tunnels	Hydrants and pipes are not prescribed, but if they are installed the following parameters must be met: 20 l/sec, hydrants every 150 m, reservoir 250 m <sup>3</sup>	No reference
<b>Germany</b>	Two portable extinguisher of 6kg every 150 m	Tunnels with length $\geq$ 600 m must be equipped with fire hydrant with capacity of 1200 l/min at 6 - 10 bar. The connectors are placed opposite the emergency points at distances less than 150 m.	No reference
<b>Austria</b>	In tunnels longer than 500 m the firefighting equipment must be located every 250 m	Hydrants with capacity of 20 l/s for 1 hr; just for tunnels 500-1000 m	No reference
<b>Norway</b>	One extinguisher at distance between 250 to 62.5 m according the tunnel type	separate reservoirs of approximately 6m <sup>3</sup> in connection with the drainage system, a water tanker vehicle with sufficient capacity (approximately 6m <sup>3</sup> ) firewater reservoir at the low point of the tunnel	No reference
<b>United Kingdom</b>	Hose reels at 100 m intervals	Pressurized fire hydrants and hose reels according the tunnel type	Automatic fire extinguishing systems are not considered suitable for the traffic space.. Water sprinkler systems may cool buoyant smoke causing immediate smoke logging of the tunnel and producing potentially explosive air/vapor mixes.

<b>Netherlands</b>	Hose reels at 60 m intervals		Fixed fire suppression mitigation systems as sprinklers can be used for mitigating the heating of the concrete and the reinforcement.
<b>USA</b>	Portable fire extinguishers shall be located along the roadway in approved wall cabinets at intervals of not more than 90 m, and maximum weight of 9 kg	Hose connection spacing shall not exceed 85 m. The required flow rate for the standpipe system shall not be required to exceed 1920 L/min	Where sprinklers are installed in road tunnels the system shall be installed in accordance with <i>NFPA 13</i> , Standard for the Installation of Sprinkler Systems.
<b>EU</b>	Placed in emergency stations with 2 portable extinguishers located in new tunnels every 150 m; for existing tunnels at not more than 250m	Hydrants shall be provided near the portals and inside at intervals which shall not exceed 250m.	No reference

Table 2.15 Safety equipment of Fire Fighting System

#### 2.3.4.7. Power supply

In case of an emergency, especially a fire, it is necessary to have a reliable supply of power to operate the safety systems such as lighting, information and communication systems etc. It is also considered that the ventilation shall be able to operate on demand, which may require power supply from two sides.

<b>Country/ Organization</b>	<b>Requirements</b>
<b>France</b>	In the event of an incident or accident occurring when there is cut in the external power supply, essential safety equipment shall be powered by an uninterruptible power source (generally a charger - battery - DC/AC converter unit) having an independence time of at least half an hour in the event of failure of the external power supply. <ul style="list-style-type: none"> <li>- emergency lighting and marker lights</li> <li>- lighting of facilities for the evacuation</li> <li>- signage and marking of safety equipment</li> <li>- pollution sensors and anemometers,</li> <li>- information systems</li> <li>- function of monitoring and control rooms.</li> <li>- signaling devices</li> <li>- closed-circuit television, automatic incident or fire detection,</li> <li>- radio-communications relay equipment,</li> <li>- barriers</li> <li>-ventilation system</li> </ul>
<b>Switzerland</b>	For lighting two independent power supply sources or an emergency power supply is needed. This must guarantee a lighting capacity of 1/10 of normal capacity. If there is a fault in the lighting steering systems, the lights must switch on automatically. The emergency power supply must guarantee the function of signals, monitoring devices, emergency lighting, control room lighting
<b>Germany</b>	The UPS (unbreakable power supply) shall be designed for the clearance period of the tunnel. (15 - 60 min). Closed maintenance free batteries shall be used. It shall sufficiently supply: <ul style="list-style-type: none"> <li>- signage for emergency escape</li> <li>- emergency lighting in case of fire</li> <li>- emergency lights</li> <li>- escape route lighting</li> <li>- Illumination of operational rooms, minimum one lamp per room</li> <li>- traffic control systems in the tunnel and at the approaches as far as it is necessary</li> <li>- fire alarm systems</li> <li>- control systems</li> <li>- monitoring systems</li> </ul>
<b>Austria</b>	Normal power supply from both portals, Emergency power supply with automatic switches that ensure interruption time of 0.0 seconds Following systems must be connected to the emergency power supply: <ul style="list-style-type: none"> <li>- Steering and control system of power supply</li> <li>- Ventilation system</li> <li>- Traffic regulation and control system</li> </ul>

	- Emergency call and communication system - Emergency lighting
<b>Norway</b>	The following equipment shall be connected to unbreakable power supply (batteries or generator) for at least 1 hour: monitoring, management, red stop signal, priority lighting, escape lighting, Emergency telephone, service signs, Emergency exit signs, communication and broadcasting systems.
<b>United Kingdom</b>	In the event of failure of the normal power supply an alternative source of power will maintain power to operational and safety systems and permit use of the tunnel to continue. The components of the essential load shall include i. Approximately 10% of the Stage 1 lighting ii. Computer control and fault indication systems iii. Sub-surface communications systems including CCTV iv. Radio Systems v. Tunnel portal signals/signs vi. Fire Brigade power tool sockets
<b>Netherlands</b>	Functions, during normal operational functioning of the tunnel, which is indicated as critical in regard to power supply: tunnel lightning, measurement and detection systems, traffic detection (e.g. SOS), barriers, guarding of buildings, control panel, lightning in emergency escape tunnels. Functions, during calamities, which are indicated as critical in regard to power supply: tunnel ventilation, ventilation in emergency escape tunnels, system of fire suppression (fire extinguishers, hose-reels etc.)
<b>USA</b>	The power source for all systems shall be of a capacity and configuration commensurate with the purpose of the system. The following systems shall be provided with reliable power for a fire emergency: (1) Lighting (2) Lighting for means of egress and areas of refuge (3) Exit signs (4) Communications (5) Tunnel drainage and fire pump(s) (6) Ventilation during a fire emergency
<b>EU</b>	All tunnels shall have an emergency power supply able to ensure the functioning of safety equipment indispensable for the evacuation until all users have evacuated the tunnel. Electrical, measurement and control circuits shall be designed in such a way that a local failure, such as that due to a fire, does not affect unimpaired circuits.

*Table 2.16 Safety equipment of power supply*

### 2.3.5 Additional issues

Nowadays road tunnels are employed for crossing long distance. Thus, additional issues have to be taking in account from the point of view of safety. Due the users is the main factor for safety within a tunnel, their perspective is a really important role to be considered.

Some recommendation made for the Norwegian Public Road Administration (NPRA) for its long road tunnels are:

- Geometrical Internal variations
- Lighting which breaks the monotony
- Variations afforded by the line and geometry of the tunnel.

A fact is that an adequate internal design of a tunnel could improve the comfort for drivers in case of long tunnels. Dividing the tunnel into sequences and spaces along the tunnel, could simulate the felling of drive in many short tunnels against one single tunnel. This can be achieved with the lighting design.

In long tunnels in particular, the monotony can be broken by creating variation with the aid of illumination. One solution can be to choose special illumination, for example in niches or emergency lay-bys. In addition it is possible vary the cross-section throughout the tunnel. Small “mountain halls” along the tunnel can give the effect of a “breathing space” and contribute to breaking the monotony to which drivers are subjected. This can

be solved through redesigning elements already planned such as emergency lay-bys, turning points, pumping stations and others (NPRA).

In addition, the aesthetic design in modern tunnels is an important issue to be considered. Surely, drivers would feel more comfortable in a modern designed road tunnel where can be exploited the new technologies of lining and lighting than in a typical illuminated tunnel. In Figure 2.29 can be appreciated modern cross section design for road tunnels.

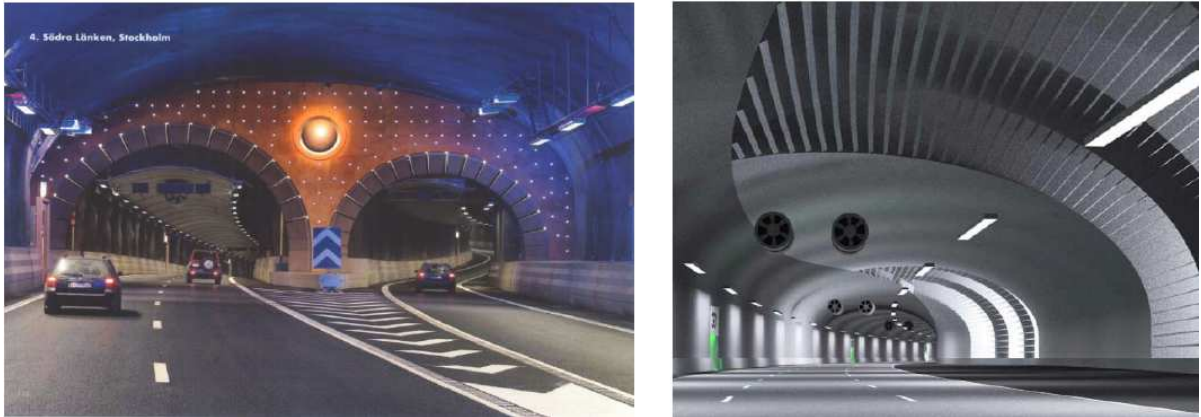

Figure 2.29 Sketch of modern road tunnels in Stockholm (Trafikverket)

#### 2.4. Construction systems for Immersed Tunnels

Immersed Tunnels are considered precast tunnels due their construction process. They are composed by elements fabricated in shipbuilding, casting basins or dry docks sealed at their ends by bulkhead. Then the elements are towed until the project site for finally immersing them until the bottom of the water crossing. Finally the elements are protected by filling material in order to protect them against ship impacts or severe hydrodynamic actions. Previously to the sinking of the elements, the bottom of the crossing shall be dredged in order to give the needed clearance from the surface. In case of poor conditions of the soil, adequate treatments must be realized in order to guarantee the stability of the structure, mainly for settlements actions. An advantage of IMT process is that the fabrication plants can be remote from the project site because the elements can be towed due their buoyancy capacity.

Basically, there are two traditions in immersed tunnel design: The American and the European. The difference between them focuses on the selection of the construction material; steel in the USA and concrete in Europe. Within this tradition, local economics and specific project conditions also play their role in determining the choice between steel and concrete.

In general the process of construction is similar. However, the main difference between both solutions is the towing and sinking process. The steel immersed tunnel elements are usually fabricated in ship yards or dry docks similar to ships, and can be transported on a barge for then launching them into water (Figure 2.30a). Finally the concrete is poured while afloat. Steel tunnels can have an initial draft of as little as about 2.5m (De Wit, 2012). On the other hand, concrete immersed tunnels are usually cast in dry docks or specially built basins and then the basin is flooded what produces the buoyancy of the elements for later towing by barges until the project site (Figure 2.30b). In this case the tunnel elements usually have a draft of almost the full depth.



Figure 2.30 Towing process of Immersed Tunnel element: (a) Steel element; (b) Concrete element (De Wit et al., 2012)

#### 2.4.1 Steel Immersed tunnel

This element generally have a circular cross section shape, thus are also know as steel tube tunnels. There are two variations in the construction process of the tunnel: single-shell and double-shell construction.

In single-shell construction method, an outer steel shell plate stiffened internally acts as a permanent watertight membrane; serves as an exterior form for the concrete lining and acts as the structural element to carry flexural forces along the exterior face of the tube before and after the placement of the concrete lining (Gursoy, 1995). After completion of the interior concrete, the steel shell tube behaves as a composite steel-concrete structure. The tube is generally protected against corrosion by a cathodic protection system or by pneumatically applied concrete protection. A convenient ballast box is placed at the top of the tube section, permitting the use of economical stone ballast.

In double-shell construction, an outer secondary shell plate, usually octagonal in shape, is added. The outer shell plate (often called a "form plate") provides needed space for placement of tremie concrete as ballast. The outside ballast concrete protects the inner shell plate from corrosion, leaving the outer shell plate as a sacrificial form plate. The inner shell plate for double-shell construction provides design features similar to the single shell construction. However, unlike the single-shell construction, the stiffening elements of the inner shell plate (the transverse diaphragm and longitudinal stiffeners) are placed outside the inner shell plate (Gursoy, 1995).

The Figure 2.31 shows both configurations of steel tube immersed tunnel, both single-shell as double-shell.

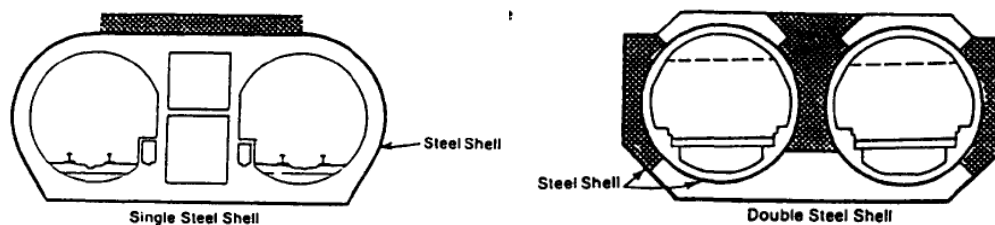

Figure 2.31 Conceptual configurations of Steel Tube Immersed Tunnels (Gursoy, 1995)

#### 2.4.1.1. Materials and fabrication of steel shells

Steel tubes can be constructed on shipbuilding ways of adequate size or in casting basins or dry docks. These fabrication plants may be remote from the project site; because the prefabricated steel tubes draw minimum draft, they can be towed considerable distances. Material for the shell plates, stiffening members, and end bulkheads are usually ASTM-designation A36 steel (Gursoy, 1995).

The tube is obtained by linking tubular sub-elements. Each of these sub-elements is fabricated with shell plate panels of convenient size usually 3-4 m long. Then stiffeners are welded to the external or internal surface of the steel tube according the structural design. After, the panel is transferred to a serrated rolling table for executing the special rolling fixture and then the extreme edges are butt-welded. After the set up of the sub-elements, they are mutually welded in the transversal direction. This process is shown in the Figure 2.32.

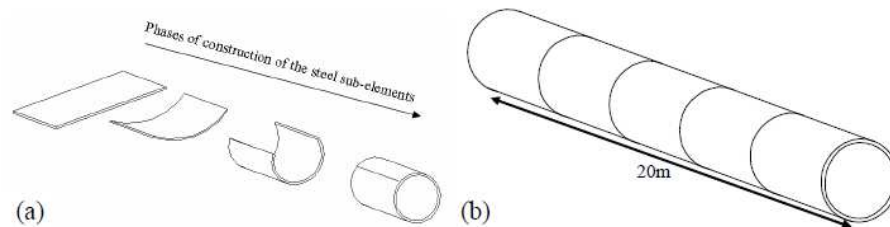

Figure 2.32 Construction process of the steel tube: (a) sub-elements; (b) Completed element (Martire, 2010)

All joints are welded by the metal arc-welding process. Joints in shell plates are full-penetration butt welds. Where practical, welds are made by the automatic machine process. The welds are lightly stressed in permanent conditions and are used primarily for water tightness. The welds are visually inspected throughout the fabrication process and a certain percentage is tested by radiographic, ultrasonic, dye penetration, or magnetic particle methods, or by other methods. Usually, 10 percent of the butt welds in the end bulkheads and in the end sections of the steel shells and 1 percent of the remaining butt welds in the shell plates are tested radiographically (Gursoy, 1995). All shell plate welds are tested for water tightness before launching by coating the outside of the shell plate with soap solution and jetting compressed air at 40 psi against the inside or by using a vacuum box. Similar testing methods are applied to welds in end bulkheads. All leaks are repaired and retested. During fabrication at a shipyard, tubes are supported on the ways by blocking under diaphragms or by stiffener rings. Before launching, the ends of the tubes are closed with watertight bulkheads. It is advantageous to place the interior reinforcing steel before the bulkheads are attached.

#### 2.4.1.2. Launching of tubes

Structurally, the tubes are particularly suitable for side launching, but may also be end-launched. In addition other variations of the launching process can be executed. The description of each process is described here below:

- Side launching. The tubes are supported by launching sleds on a series of parallel ways at right angles to the tube and located under diaphragms that are designed to transfer the weight of the tube to the sliding ways. The actual launching may be free or restrained, depending upon the declivity of the ways and the depth and width of the waterway at the launching site. During the restrained launching the speed is controlled by chains or other suitable drag devices. These control the displacement of the tube in the water. On the other hand, in the controlled side launching the tube is supported on the sled is



gradually allowed to slide down the ways at a suitable speed, controlled by synchronized winches, until it floats off the sleds (Figure 2.33).



Figure 2.33 Side launching of a tube element (De Wit et al., 2012)

- End Launching. In end launching, the tube slides on two ways parallel to its longitudinal axis. After its weight is transferred to the launching ways, a single trigger holds the tube until it is released for the launch.

#### 2.4.1.3. Placing of concrete

After launching, the tube is towed to an outfitting site for placing of the interior concrete lining. The keel concrete is usually placed prior to launching in order to provide stability and to reinforce the shell and form plates. If the keel concrete is placed after launching, the shell and form plates probably will require additional stiffening (Gursoy, 1995).

For large projects, concrete is usually supplied by a plant at the outfitting site; on smaller projects, it may be supplied by transit mix. Concrete is placed into movable steel forms by pump lines extended through access hatches in the top of the shell. For concrete placement while the steel shell is floating, minimum hatch openings of about 15 to 20 cm by 10 cm are provided at approximately 22.5 m centers for form handling. Small openings (30x30 cm) may be provided in the top of the steel shell to facilitate placing of the arch concrete (Gursoy, 1995). The pouring sequence is controlled to prevent excessive hydrostatic pressure on the shell at successive increases in immersion, and to maintain the tube in level condition for trim and list. Placing of concrete starts at the invert and proceeds in increments on the haunch, sidewall, and arch pours. The roadway slab in highway tunnels is also placed at this stage.

The length of the pours is determined by the above considerations and by convenience in the length of forms. Placing should start approximately at quarter points of the tube and proceed in both directions simultaneously. Construction joints are provided with keys. Figure 2.34 shows a typical pouring schedule and sequence.

Buoyancy and stability of tube sections for progressive stages of concreting are checked from the time of launching throughout towing to the tunnel site. Keel concrete is usually placed before launching and the structural cap concrete is placed in the dry at the outfitting pier. After all interior concreting is completed, all of the access hatches and concreting openings in the shell are closed by steel plates welded watertight. The Gaps between the shell plate and the interior concrete lining are similarly grouted.

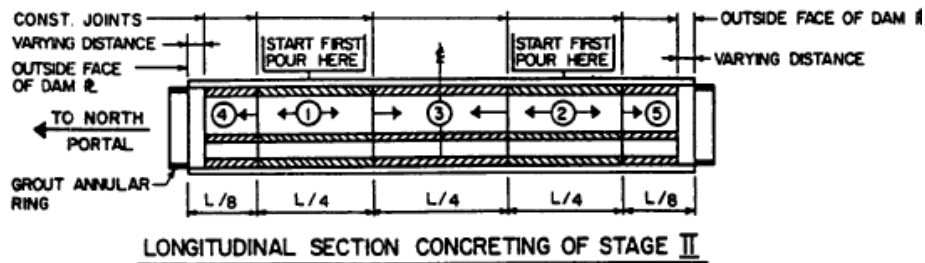
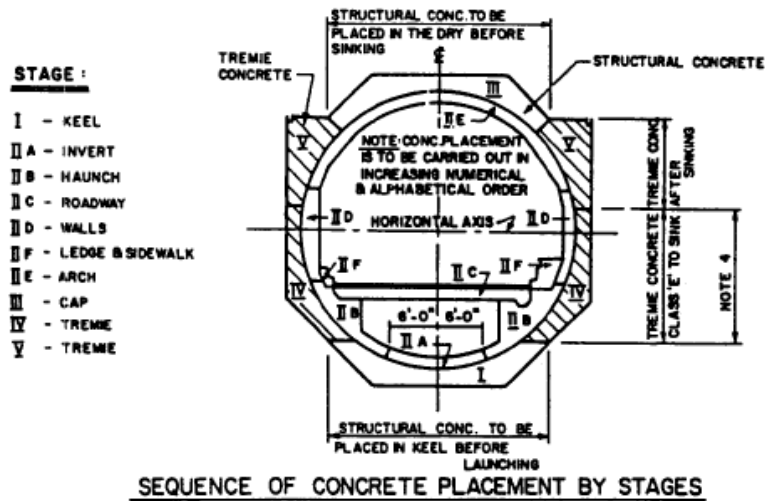

**NOTES :**

1. EACH SEGMENT OF STAGE II CONCRETE SHOWN IN "SEQUENCE OF CONCRETE PLACEMENT BY STAGES" IS TO BE PLACED IN THE FOLLOWING ORDER: POUR (1) & (2) TO THE CONSTRUCTION JOINTS, POUR (3) TO THE CENTER OF THE TUBE BETWEEN JOINTS, POUR (4) & (5) TOWARDS THE ENDS OF THE TUBE AS SHOWN IN "LONG. SECTION CONCRETING OF STAGE II".
2. STAGE II F SHALL BE MADE AFTER THE TUBES HAVE BEEN SUNK AND OPENED.
3. CARE IS TO BE TAKEN WHILE POURING ALL TUBES TO MAINTAIN THEM IN A LEVEL POSITION.
4. DIMENSIONS TO BE DETERMINED BY THE CONTRACTOR AND APPROVED BY THE ENGINEER.

*2.34 Sequence of concrete pouring in the tube elements (Gursoy, 1995)*

2.4.1.4. Tube transport

The transport of the elements of the tunnel is an important issue that involves some considerations such as:

- Hydraulic and meteorological conditions at the site (waves, currents, density, wind, rain, tidal, etc.).
- The behaviour of the tunnel elements under the specific conditions at the site.
- The space available in the navigation channel.
- The type and capacity of the tugs.
- The location system and the way that these results are presented to the operation leader.
- The organization of personnel and equipment involved in the transport operation.

The capacity and the number of tugs depend upon the resistance of the tunnel elements in the river, canal, or at sea, as well as the space available for maneuvering. Another decisive may be the fleet available for the specific location. It is preferable to limit the number of tugs in order to limit the problems in the maneuvering process.

When the available space is narrow, an accurate and fast-working navigation system is required to provide information about the position of the tunnel elements in the available space. In the case of crossing throughout a bridge or a lock it is necessary employee winches.

In addition, a computer model has been developed called Ship Response System. This aid forecast the forces on and in the structure, and it can be used in complicated situations as well as severe natural conditions at the site.

#### 2.4.1.5. Immersing process

Prior to immersing, the tunnel elements are attached to the immersing pontoons. These pontoons normally consist of a set of two or four pontoons with bridges in between them. The tunnel element is suspended from these bridges (Figure 2.35). In order to increase the weight of the steel tunnel elements, they can be ballasted by additional concrete and/or by gravel. This ballast is placed on top of the tunnel element when it is suspended from the immersing equipment. The immersing takes place when the tunnel elements are lowered with winches on the pontoons. When the tunnel element is dose to the bottom, it is lowered against the previous element before being placed on the gravel bed foundation. Temporary jointing is accomplished with rubber gaskets; permanent joints are made after the temporary bulkheads are removed.



*Figure 2.35 Immersing process of a steel immersed tunnel (FHWA)*

#### 2.4.1.6 Joints between elements

Apart from the corrosion concerning considerations in steel immersed tunnels, the waterproofing is another important issue to take in account. Due the steel shell can be consider as the waterproofing layer, special attention must be taken in the joint area.

In the early practice of steel immersed tunnels in the USA, it was employed a special joint made up of tremie concrete. The tremie joint was mated and aligned and then pinned with two heavy steel pins. A form was installed on both sides of the joint and a massive tremie concrete pour was made (Figure 2.36), which completely enclosed the joint and hopefully sealed it sufficiently to allow the internal liner plates to be welded in place without great difficulty. This was not always the case, however, because tremie concrete is often imperfect. The joints would leak or worse yet, the concrete would penetrate into the interior of the joint and

harden, requiring a time-consuming “mining” operation to remove it (Grantz et al., 1993). On the other hand, the tremie joint had one major benefit: it formed a rather strong structural connection between the elements.

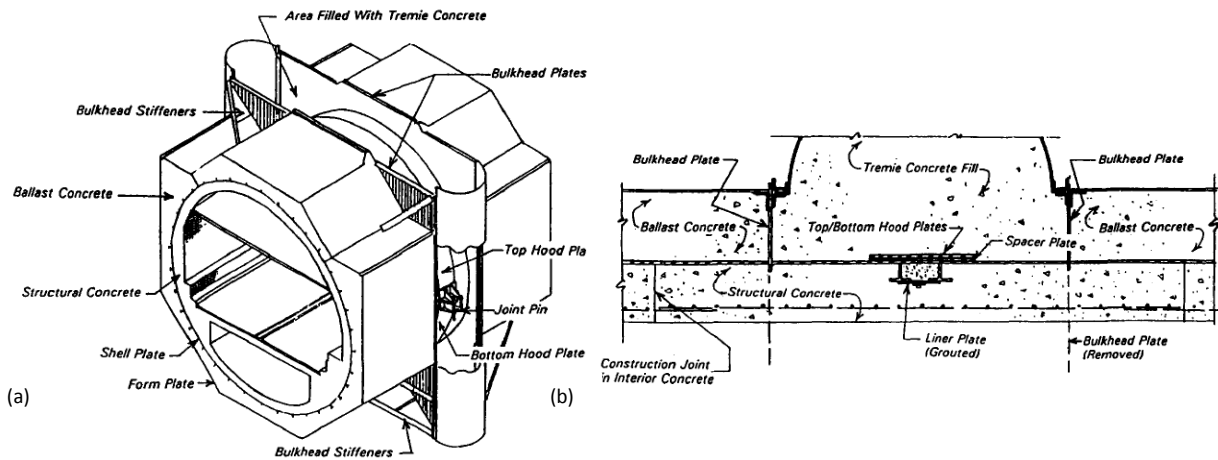

Figure 2.36 (a) Typical tremie joint in a double-shell structure; (b) detail of the tremie joint (Grantz et al., 1993)

In recent years newer joints for steel immersed tunnels have been developed. The new typical joint is designed to permit longitudinal movement generated by the temperature variation during seasonal cycles. It is also designed to transfer shear forces caused by seismic events, as well as differential settlements, which might cause small rotational movements in the joint.

The Omega gasket seals against water that might escape past the main exterior gaskets, and conducts it around and down to a drainage valve in the invert of the element. The valve relieves the pressure and drains the Omega gasket into the lower air supply ducts. Although the Omega is rated for the ambient exterior water pressure, the main gaskets do most of the work; only a slight seepage or trickle might have to be intercepted by the Omega gasket (Grantz et al., 1993).

The interior structural ring in the joint area is mainly the typical structure, composed of the steel shell tied compositely to the concrete. However, 60 cm of the joint ring concrete overlaps from one tube to the other, to provide a full structural shear key from element to element. This overlaps allows relative longitudinal motions between elements, by virtue of the fact that the concrete is entirely isolated from the steel shell in this zone by a section of joint filler that prevent bonding or jamming of the shear ring as it gradually moves in response to expansion and contraction (Grantz et al., 1993).

The Figure 2.37 illustrates the current design for steel tube joints.

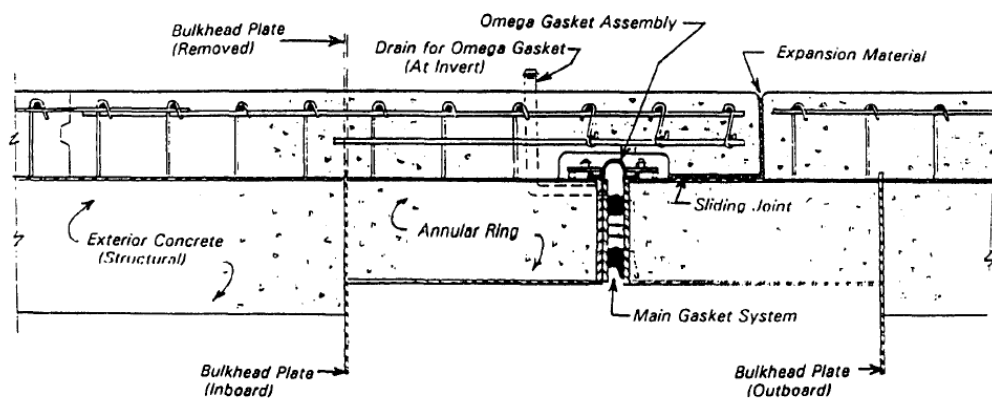

Figure 2.37 Current joint for steel immersed tunnels (Grantz et al., 1993)

#### 2.4.1.7 Land connection

A great solution was developed for land connection in seismic area. The joint was employed in the BART Transbay tunnel in the USA (Figure 2.38). The seismic joint was designed to allow triaxial displacements of  $\pm 8$  cm in the longitudinal direction and  $\pm 15$  cm in any direction in the vertical plane, while waterproofing is met. The vertical and transverse horizontal motions are permitted by precompressed rubber gaskets sliding on radial Teflon bearing surfaces. The longitudinal motion is taken by similar gasket sliding on a circumferential Teflon bearing surface. Both sets of bearing are compressed by tensioned cables that allow the motions by rotating on Teflon-coated spherical bearings. The assembly is protected from mud and the marine environment by exterior rubber boot enclosures. These assemblies were prefabricated, assembled and tested as units before being attached to the elements. Four of these seismic joints were required for the Transbay Tunnel. The joints performed well during the 1989 earthquake in San Francisco (Grantz et al., 1993).

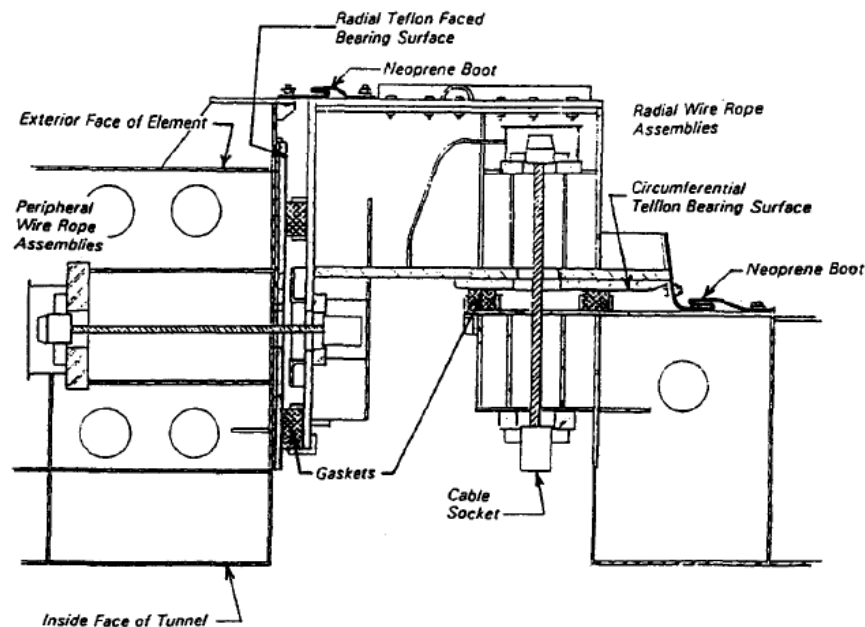

Figure 2.38 Patented seismic joint used for the BART Transbay tunnel, San Francisco (Grantz et al., 1993).

#### 2.4.2 Concrete Immersed Tunnel

The concrete solution for immersed tunnels is the most common practice in Europe. Since this solution for waterway crossing began, the construction method has been simplified and optimized. The main principle of a concrete immersed tunnel is that the tunnel elements are made of reinforced concrete, which serves for structural purposes as well as for ballast. Although most immersed tunnels built recently do not have a watertight membrane, older tunnels (as well as some more recent ones) typically used a watertight membrane of steel or asphalt bitumen.

Most completed concrete tunnel elements consist of a number of segments, limited in length to approximately 20-25 m, linked together by flexible joints. Because each segment is a structural entity, it is easier to control the concrete placement and to limit the structural forces in the elements. A few concrete tunnels have stiff tunnel elements.

#### 2.4.2.1 Element production

Basically there are two solutions for fabricating the concrete elements: monolithic or by segments. The first solution has been employed until nowadays when the feasibility study allowed it. Generally, is used in short tunnels or when the size of the dry dock is enough for hosting all the elements of the tunnel. It is a slower solution for fabricating. On the other hand, the production by segments is the most recent solution for IMT technology. It allows fabricate the elements faster than the monolithic solution what is really advantageous for long tunnels. In addition the early cracking for the massive concrete pouring can be avoided.

##### 2.4.2.1.1 Monolithic production

Until almost 20 years ago this was the typical solution for constructing the elements of an immersed tunnel. The general process follows these steps:

- I. After form the casting basin or dry dock it is placed the bottom formwork and the reinforcement steel is collocated.
- II. The concrete of the bottom slab is poured in one single process.
- III. It is collocated the reinforcement steel of the walls and a mechanized formwork is placed in both walls for then pouring the concrete.
- IV. Similar process is made with the slab of the element placing the steel and concrete.
- V. Once the full element is fabricated, a couple of bulkheads are assembled at the ends of the element. These seals will allow the buoyancy of the element for later being flood out of the basin.

In this process some additional considerations must be taking in account, mainly in the concrete placing. Due to the massive concrete pouring early age cracking is a constant concern which would have as consequence the leaking in the tunnel. The use of pipes for cooling the concrete has become in a great solution for controlling the concrete temperature and decrease the presence of cracks. In addition, some membranes composed of steel on the bottom, outer walls and even on the roof have been employed. Alternatively, bituminous membrane has been used on the outer walls and roof.

##### 2.4.2.1.2 Segmental production

The start point of this practice began in the Oresund Tunnel (3.5km) which is part of Oresund Fixed Link between Denmark and Sweden. Due the great length of the tunnel executed the project with the conventional method at that time would have involved a huge excavation and extensive groundwater lowering for a period of year. This process could have caused migration of contaminated groundwater and create a threat to aquifers. In addition, creating such a huge dry dock for all the elements of the tunnel would not be economical feasible. Therefore, it was necessary developed a new method for reuse the facilities and producing elements faster than conventional methods.

Nowadays, the longest concrete immersed tunnel projects are produced by segments. The general process consists in the following steps:

- I. Reinforcing steel is delivered to site cut and bent.
- II. Reinforcement is assembled into panels (slabs and walls) in a factory building, utilizing purpose designed hoists for access instead of scaffolding.
- III. The completed panels are lifted by gantry crane to an assembly area, where they are assembled into a complete cage for a tunnel segment.
- IV. The completed cage is skidded about 50 m into the casting facility, also within the factory.

- V. Sophisticated steel formwork is hydraulically maneuvered into place around the reinforcement.
- VI. The concrete of the complete tunnel segment is placed in a continuous process. Concrete for the pour is pumped from dedicated twin batching plants which are located near of the casting bed.
- VII. After few days, the formwork is stripped, and the completed segment is ready to be jacked out of the casting pit. During pushing, it is supported on a group of active hydraulic jacks, connected together in groups. After pushing, the completed segment is still in the factory building.
- VIII. Reinforcement for the following segment is skidded into the casting facility, and the formwork slid into position. The completed segment forms a stop end for the new segment, which is match-cast against it. The only connection between segments is a groutable waterbar, cast into both segments.
- IX. The process is repeated. When the growing tunnel element is pushed for the third time, the first segment begins to leave the factory through a carefully sealed aperture, ensuring that external weather conditions do not affect the factory environment.
- X. Once enough segments have been cast, they are prestressed together and pushed a further 100 m or so, so that the whole element is located within a bunded dock area. A sliding gate is closed between the element and the factory.
- XI. Finally, water is impounded within the dock to about 10 m above sea level, permitting the completed element to float. It is then winched into deeper water and lowered into the sea using the same principle as a canal lock.
- XII. Whilst the completed element is being immersed in this way, the factory is able to continue with construction of further tunnel segments. There are no breaks in production.

The main benefits of this process are listed here below (Marshall, 1999):

- The time taken to build the casting facility, construction is faster, reducing overall programme risk for the project.
- Concrete construction is continuous and hence labour demand is uniform.
- All reinforcement handling and assembly is off the critical path.
- Fresh concrete never has to travel more than 100 m from the batching plant.
- All reinforcement, formwork and concreting activities are performed indoors in controlled conditions, offering the opportunity to deliver the highest quality standards.
- Early age cracking is eliminated without recourse to artificial cooling of the concrete.
- Factory conditions allow the use of long reinforcing bars and mechanical handling, permitting a sharp reduction in reinforcement quantities.
- Temporary works stresses are never allowed to exceed those experienced by the element in its permanent condition.
- Temporary excavation and groundwater lowering are on a much smaller scale than would otherwise be required.
- The main reinforcement, formwork and concrete construction area never has to be flooded for tunnel float out.

In Figure 2.39 is shown a typical plant for producing concrete elements of an immersed tunnel.

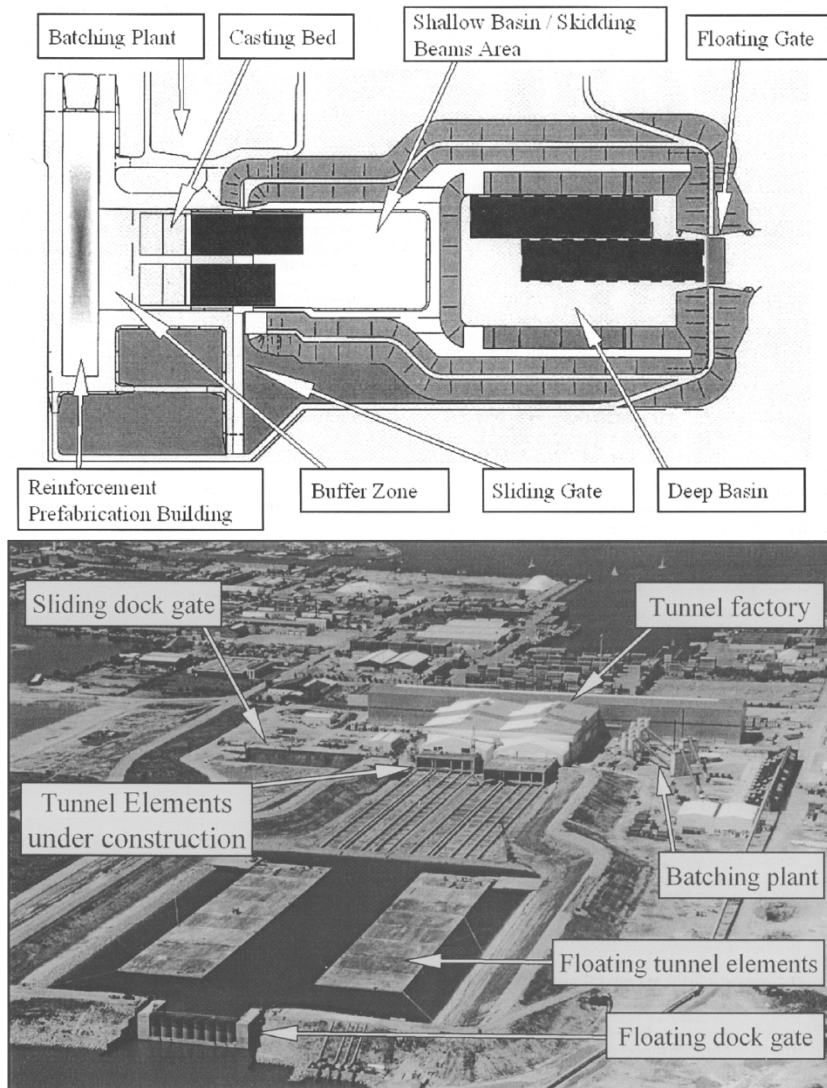

Figure 2.39 Production plant of the Oresund tunnel (Marshall, 1999)

#### 2.4.2.2 Transport of elements

The horizontal control of the tunnel element normally is created by winches, anchor lines and anchors in the water or ashore. These winches can be placed on the pontoons. However, when the current is fairly strong, it is important to have direct control over the movements of the element. This can be achieved by placing the winches in towers on top of the tunnel elements.

Alternatively, the winches can be placed ashore. Attaining horizontal control involves the following steps:

- I. The tunnel elements are towed or winched to the immersing site.
- II. While the elements are still afloat, the tugs are replaced by winches connected to anchors in the river or ashore.
- III. During the lowering of the tunnel element, the horizontal position of the tunnel element is checked continuously.



- IV. Subsequently, the tunnel element is placed with the primary end on a guiding structure on the secondary end of the previous tunnel element.
- V. The tremendous water pressure pushes the tunnel element firmly against the previous element, at the same time dictating the direction of the axis. The final axis of the tunnel is very much dictated by the precise measurement of the end rings of the tunnel elements containing the Gina gasket.

#### 2.4.2.3 Immersing process

Vertical control of concrete tunnel elements may be different from control of steel elements. After these tunnel elements have been built in the casting yard, they are ballasted with water in order to remain at the bottom of the dock, while it is filled with water. The ballast water is pumped out of the tunnel elements to make them float. The equipment most often used consists of pontoons adapted for the job. These pontoons are placed on top of the tunnel elements, either before the element is put afloat or at a later stage by floating cranes. The pontoons are equipped with winches to anchor both the tunnel elements and the pontoons or the pontoons only. After the tunnel element has been moored to the anchors, the ballast tanks are partly refilled with water until the tunnel element has sufficient negative buoyancy. If additional ballast is required during the immersing because of a change in density, water can be added.

Another option is to use additional floating bodies or stability towers with the tunnel elements. The stability towers, which are placed on top of the tunnel elements, need to have both sufficient floating capacity and a sufficiently large cross-section at the water level. The combination of stability towers and the ballast water provides excellent control of the tunnel elements. When the tunnel elements are near the final position, they are placed on a temporary structure on the previous element, and on temporary struts at the free (or secondary) end of the tunnel elements. The final positioning is done with jacks in these struts, thereby allowing for correction of settlement, misplacement, etc.

#### 2.4.2.4 Joints between elements

Nowadays the most common devices for link two elements are the Gina gasket and Omega seal. The process for joint two elements follows the next steps (Figure 2.40):

- I. The Gina gasket acts as primary seal for the elements. It is mounted on the steel frame around the cross section at the end. Once both elements are in contact the Gina gasket is compressed and impede the water pass.
- II. The water inside of both elements is drained throughout hatches placed at the end bulkhead.
- III. It is placed the omega seal since the inner gap between both end bulkheads which has the function of main seal.
- IV. It is removed both bulkheads of the elements. The process is repeated in each element placing of the tunnel.



Figure 2.40 Conceptual processes for linking two elements (Trelleborg Baker, 2008)

## Chapter 3

### Environmental conditions in the Gulf of California

#### 3.1 Generalities of the Gulf of California

The Gulf of California is an extension of the Pacific Ocean which is located between the peninsula of Baja California and the states of Sonora and Sinaloa, in northwestern Mexico (Figure 3.1). It is also known as the Gulf of Sampoya, Sea of Cortés or Bermejo Sea. The Gulf is defined to the north by the mouth of the Colorado River and south to the marine ecological by an imaginary straight line that runs from Cabo San Lucas, Baja California Sur to the mouth of the Ameca River, the southern boundary of the state of Nayarit. This area has more than 1,500 km long and varying widths ranging from 92 to 222 km. The sea surface covers approximately 247.00 km<sup>2</sup> and reaches depths exceeding 3,000 m.

In its southern portion has a free communication with the Pacific Ocean, which largely determines its climate and oceanographic features. Its extreme latitudes are 20° 30' and 31 ° North and longitude 107 ° and 115 ° West.



Figure 3.1 States and capital map of Mexico (ArchMX)

In the Gulf of California are located approximately 900 islands and islets of which only about 300 have name (SEMARNAT, 2000). The origin of these islands is attributed to processes related to tectonic and volcanic activities. Among the most important for their environmental and economic importance are Cerralvo Island, Espiritu Santo, San Jose, San Diego, Santa Cruz, Santa Catalina, Monserrat, Del Carmen, San Marcos, San

Lorenzo, Angel Guardian, San Esteban and Tiburon , the latter being the largest in Mexico with an area of 1,208 km<sup>2</sup>.

The geomorphologic environment where is situated these extensional sea is a complicated structure which is characterized by the formation of submarine basins produced by a series of tectonic faults. Some of these basins reach depths of over 3,600 meters. The Gulf of California is made up of a series of extensional basins, caused by the separation of the Baja California peninsula from the mainland, with average speeds of 4-6 cm / year. It is estimated that its formation began about 4 to 5 million years (Lugo, 1985).

On its shores, the most important ports at each state are: Puerto Peñasco and Guaymas in Sonora; San Felipe in Baja California; La Paz, San Jose del Cabo and Santa Rosalia in Baja California Sur; Topolobampo and Mazatlan in Sinaloa.

Tides in the gulf are very peculiar and are considers among the largest in the world. They fluctuations have been measured up to 9 meters (30 feet) at its northern end. It has an immense concentration of microscopic organisms and extraordinary biological diversity due to abundant sunlight and nutrient-rich waters. These factors, as well as the crystal clear waters, have led to name this place as "the world's aquarium."

### 3.1.1. Environmental data for marine structures

The Submerged Floating Tunnel proposed in the present work is located in the Gulf of California. As this typology of waterway crossing is offshore located, it is exposed to the environmental conditions as any other marine structure. The most similar offshore structure to a SFT is a marine platform, and some of them are placed in really depth waters in different locations around the world.

Based on this assumption, the environmental information require for the design of offshore structure would be the guide for collecting information about the natural state of the Gulf of California. Thereby, the data require for evaluating the natural conditions which directly impact in the design of the SFT are:

- The depths in the possible locations.
- Soil type in the location.
- Geological Faults affecting the design.
- Seismicity for ground acceleration.
- Water temperature and its variations during the time and depth.
- Currents affecting the SFT.
- Winds velocity
- Tides and its variations.
- Maximum wave height and wave period.
- Storm conditions in the region
- Vessel traffic in the region.
- Protected Natural Areas

The aim of the present chapter is to know the environmental conditions of the whole Gulf of California, the establishment of the criteria for the location of the SFT is took en the chapter 4. In addition is studied the particular natural conditions for the selected location

### 3.2 Bathymetry

The study of the bathymetry of the Gulf of California is based on nautical charts. This tool is specially designed to meet the requirements of marine navigation, showing water depths, type of bottom, elevations, configuration and limits of shores, dangers and others aids to navigation. During its elaboration, a scale is assigned based on the use and nature of the data, determining the purpose of navigation, the coverage and quality of data that is displayed.

For the SFT design, the knowledge of the depths of the sea crossing is one of the features that become more important in their review. The Gulf of California presents great depths up to 3000 meters in the southern part, reason why not crossing solution has been realized until these days. However, thanks to the emerging technology of Submerged Floating Tunnels, crosses as the present case, which at earlier times seemed impossible, nowadays with the advances of the SFT technology can be a reality.

The data is collected from two nautical charts published by the Department of Oceanography and Climatology of the Navy of Mexico. The chart with the code SM-200 shows the bathymetry from the north part to the centre of the Gulf of California (Figure 3.2a). While the one with the code SM-300 shows the bathymetry from the centre to the mouth of the gulf (Figure 3.2b).

It is intended that the stroke of the SFT avoid crossing on protected areas by the Department of Environment and Natural Resources of Mexico<sup>3</sup>, and other institutions that protect specific areas according to the flora and fauna of the place. The mainly areas under protection are the big islands and islets of the central part of the gulf.

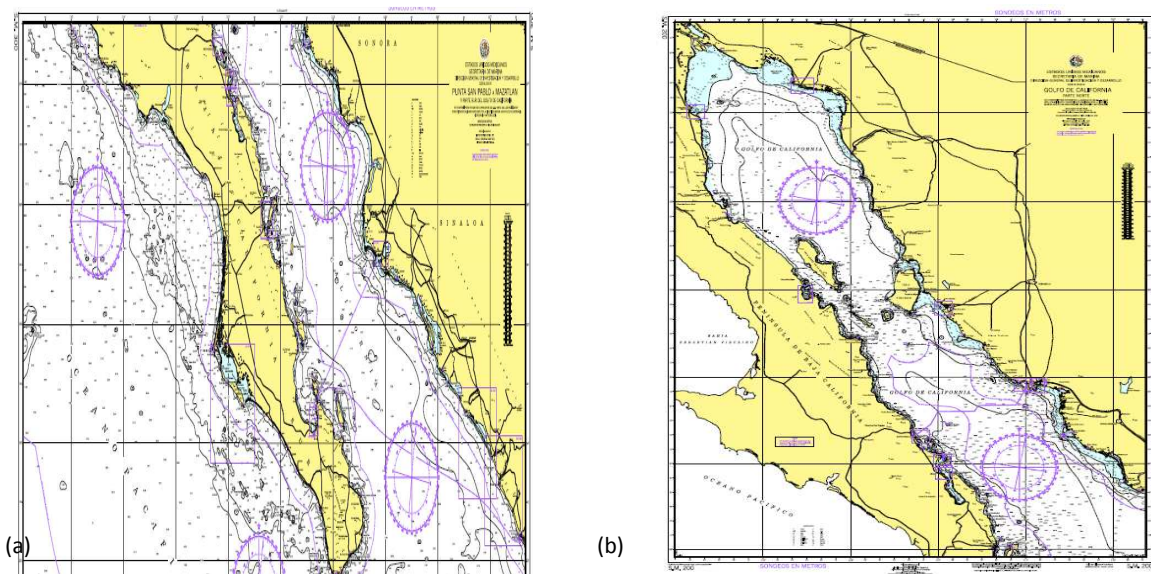

Figure 3.2 Nautical charts published by the Army of Mexico. (a) SM-200, north-central part of the Gulf of California; (b) SM-300 central-south part of the Gulf of California

In general the Gulf of California can be divided in four regions with similar characteristics (Case y Cody, 1983; De la Lanza, 1991):

- I. Northern Gulf. It is the region between the Colorado River Delta to the region of the larger islands. Funds shallow (50-200m) have a slight slope to the southwest. The seabed in this region has a lot of sediment of continental origin, most of which were carried by the Colorado River. These deposits extend a little south of the region of the large islands and in some places reach the thickness of up to 5 km.

<sup>3</sup> Secretaria del Medio Ambiente y Recursos Naturales (SEMARNAT)

- II. Region of the large islands. The fund consists of five basins in a "V". The most northern, "the Dolphin Basin" has a nearly flat background, then south, reaching 900 m depth. There goes the "Salsipuedes Basin" which is very narrow, with depths up to 1,400 m. This basin does not have large amounts of sediment because of the high speeds reaching tidal currents. The basins of "St. Stephen," "Jaws" and "St. Peter Martyr", reaching depths of 900 m. This is one of the most prominent bathymetric features of the region, and frames a unique hydrographic regime.
- III. Central Gulf. It lies between the southern boundary of the region of the large islands to Topolobampo bays on the east and west of La Paz. Its marine basins are deep. The greatest depression in the entire Gulf is Guaymas Basin, with a length of about 220 km, with depths of up to 2,000 m. The tidal range in the Central Gulf is lower than in the northern part of the gulf, with an average of 1.5 m in Guaymas.
- IV. Southern Gulf. It is in open communication with the Eastern Tropical Pacific Ocean through the mouth of approximately 200 km wide and basin whose depth exceeds 3,600 m. The hydrographic structure is complicated due to the confluence of different water masses in the mouth of the Gulf. It is a fact that the southern end of the Gulf of California region is strongly influenced by the waters of the Pacific Ocean, there takes place the biggest waves (SEMARNAT, 2010).

Despite the extreme conditions in the region, the employed of the new offshore technology can be employed for decrease the problematic complexity of the crossing. The new developments for deepwater exploration and petroleum expropriation are technologies that can be adopted for the design and construction of a Submerged Floating Tunnel. The aim of the SFT in the Gulf of California is a solution that looks for communicating the Baja California Peninsula with the rest of the country. This region currently presents a significant lag in compare to the rest of the country, thus the establishment of a crossing solution will become in a massive economic detonation of the region. In addition many social benefits for the northwest region and the whole country will receive.

### **3.3 Geology**

#### **3.3.1 Type of ground**

The Gulf of California can be divided into different oceanographic areas, due to its similarity in some features such as soil type, tides, temperature, currents and winds which may be associated as major regions.

The data collection of the ground in the Gulf of California is based on explorations made by the Mexican petroleum company (PEMEX) with the drilling of the exploration wells as wells as a geological model made by Portillo Pineda (2012). Soil stratification was based on the wells analysis whose data helps to adjust any model to reality. As is a direct method of exploration for understanding the subsurface, it represents real data for physics and stratigraphic information of the ground.

The exploration wells were made in the northern part of the gulf. The Figure 3.3 shows the location of the wells carried out by PEMEX.

In the northern Gulf of California were considered a total of four exploration wells in the marine basins: Altar, Wagner, Consag and Tiburon. The results found that the basins are filled predominantly siliciclastic material deposited between the middle Miocene to Pleistocene, and most marine sediments represent neritic environments, less than 200 meters deep. Some wells drilled in the thickness is approximately 4703 m in the

basins and Consag Shark, while the maximum thickness of 5591 m was drilled in the basin Wagner (in the well W-1). The sedimentary column consists of 2500 m of marine sandstones and shales of the middle to late Miocene, covered by 1500 m of Pliocene sandstones and shales deposited in transitional environments. These units are in turn covered with unconsolidated sands and clays of the Pleistocene (~ 1591m), representing transition facies. On the other hand we know that packets Pliocene-Pleistocene sedimentary Colorado River apparently did not reach these marine basins (Helenes et al., 2009).

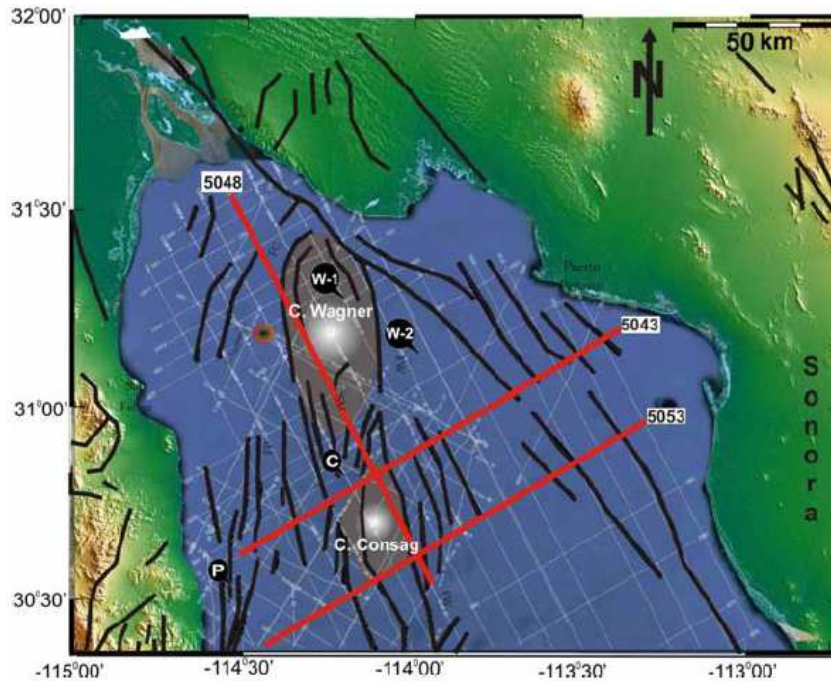

Figure 3.3 Location of the exploration wells in the Gulf of California (Gonzales et al. 2009)

The well C is located about 70 miles east of San Felipe (Figure 3.3), where were drilled 4920 meters of marine sediments (Helenes et al., 2005; Barajas et al., 2006). According to the seismic data, there are at least 500 m of sediments from the base of the perforation line. Paleontological data interval 3620-4680 m indicate an average age of Miocene seismic-stratigraphic correlation with the well W-1 (Helenes et al., 2005).

Moreover, in the well P the lithological column shows less sand intervals than the Altar basin and baseline interval consists of marine shales with siltstone and minor amounts of sandstone.

The Figure 3.4 shows the lithological column found in the wells C and P during the PEMEX exploration.



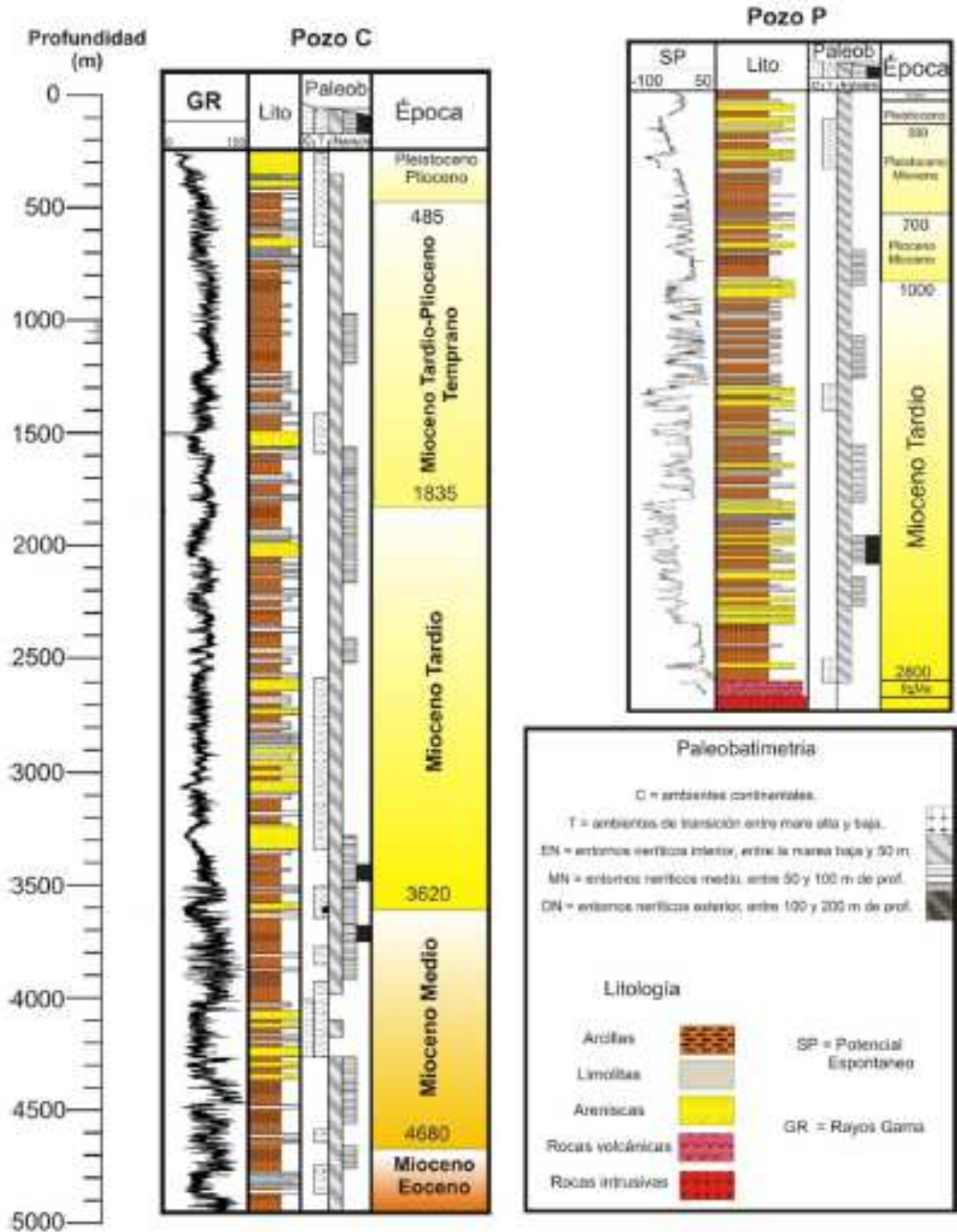

Figure 3.4 Lithological column of the exploration wells C and P (Helenes et al., 2009)

Well W-1 reaches a depth of 5590 m of marine sediments, but according to seismic data, there are at least another 2000 m of sediment below the perforation (Helenes et al., 2005, Barajas et al., 2006).

Besides the well W-2 is located about 70 kilometers at northeast of San Felipe (Figure 3.3), on the eastern flank of the basin. In this place were drilled 4325 meters of marine sediments. The Figure 3.5 shows the results of the drilling in W-1 and W-2.

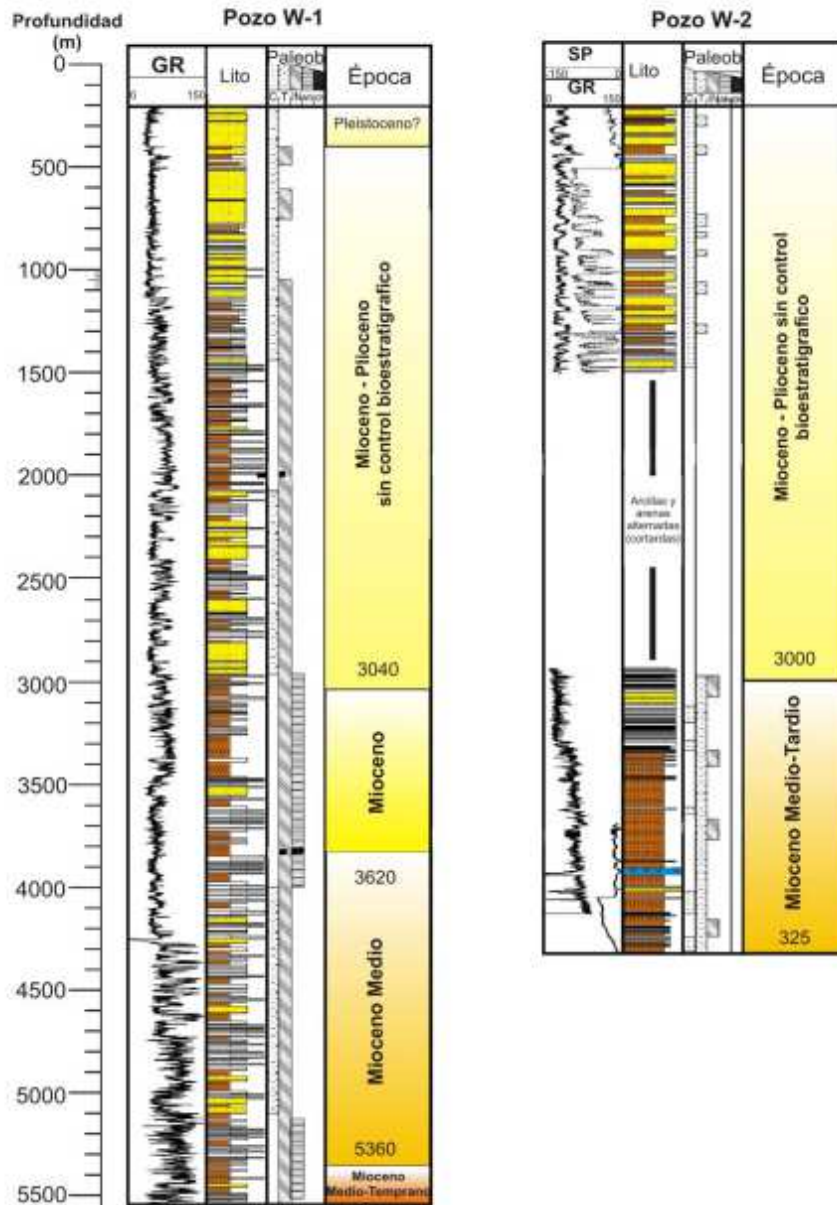

Figure 3.5 Lithological column of the exploration wells W-1 and W-2 (Helenes et al., 2009)

On the other hand, the type of ground of the southern Gulf of California varies with respect to the northern part. Due to there are not accurate data as stratigraphy or lithology of the area, it is taken the Lizarralde model (2007) in conjunction to the nautical charts issued by the Navy of Mexico.

The type of ground was generalized dividing the nautical chart SM-300 (Figure 3.2b) in nine main zones. According its latitude was divided in three parts along the gulf. Besides, the transversal direction of the gulf was divided by western, central and eastern part. The results are summarized in the Table 3.1.



Location	Latitude Limits	Type of ground		
		West	Middle	East
Central part of the Gulf	26° - 27°30'	Silts, sands, rocks	sludge	Sludge, sands
Southern part of the Gulf	24° - 26°	Sandstones, rocks	Sludges, silts	Sandstones, graves, silts
Mouth of the Gulf	22°50' – 24°	Sands, graves	Sludges	Sludges

Table 3.1 Type of ground in the central-southern part of the Gulf of California

The typology of the ground described in this section is general of the Gulf of California. Once the SFT is located according the established criteria, it is detail the type of ground along the whole section of the seabed.

### 3.3.2 Geological faults

The Gulf of California serves as the boundary between the major tectonic plates: Pacific and North America (Figure 3.6). Such limit changes its structural character along the rift<sup>4</sup>, in some portions have postulated the presence of oceanic crust, while in some segments is observed continental crust.

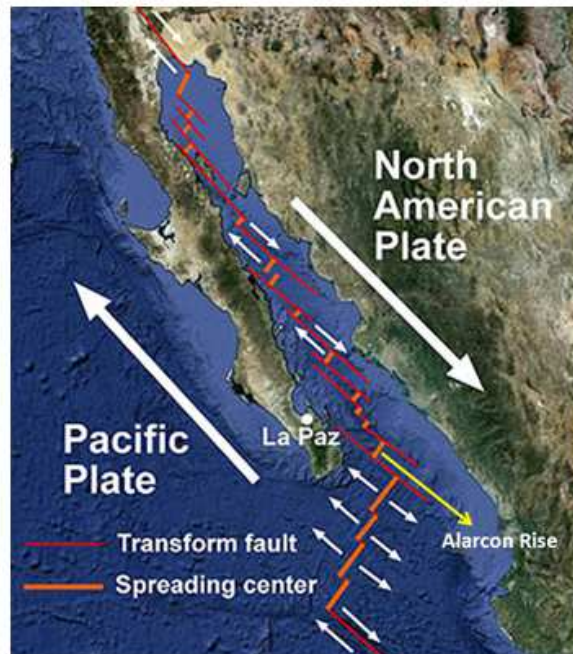

Figure 3.6 Regional tectonic map (MBARI)

<sup>4</sup> In geology, a rift is a linear zone where the Earth's crust and lithosphere are being pulled apart. Major rifts occur along the central axis of most mid-ocean ridges, where new oceanic crust and lithosphere is created along a divergent boundary between two tectonic plates. (Van Wijk)

In the southern portion, the lithosphere is fully opened facilitating the creation of ocean floor, while in the north portion, it is clear the formation of new oceanic crust and the displacement of the plates is apparently happening along the zone with extensional deformation. The deformation that occurred in the Gulf of California is characterized by a strong right side component resulting in oblique opening. The region affected by this deformation is known as Extensional Province of the Gulf (Stock and Hodges, 1989; Roldan Quintana, 2004, Fletcher et al., 2007), which overlaps with the Basin and Range provinces from the south of California and Northwest of Mexico.

According the work of Portillo (2012), it is proposed to divide the Gulf of California in three main domains once it is analyzed the fault patterns:

- I. The North domain, has been interpreted as a large pull-apart type basin which is limited by the lateral fault system Ballenas and Tiburon in South End. The Failure of Cerro Prieto and Imperial in the North, while in its western extreme by the fault system of Sierra de Juarez and San Pedro Martir. On the east is limited by the fault Amado and Del Mar. The internal depression has a high rate of sedimentation. It has been documented migration of deformation from east to west, forming a river passing overlapping (Wagner and Consag basin), and allowing lateral localization domains between them. In the Figure 3.7 shown the main structures forming a structure type "pull-apart" and within extensional duplex naming system, where the deformation is controlled in the north and south by the transforme fault systems and from east to west by the extensional fault systems.

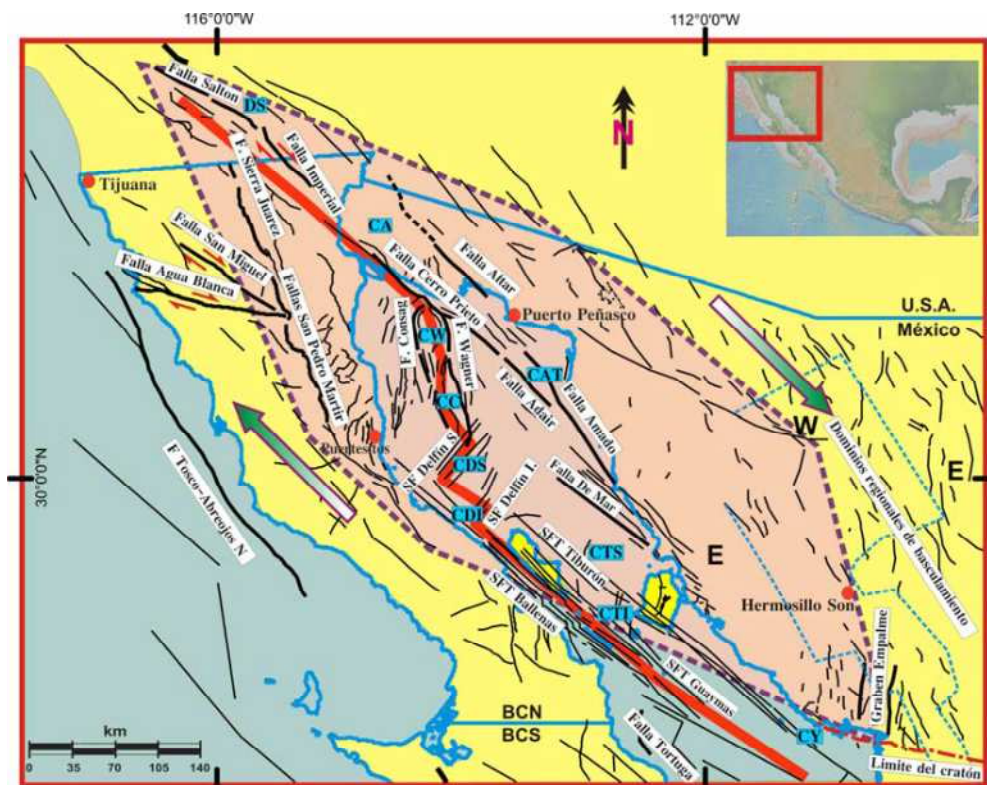

Figure 3.7 Fault system in the northern Gulf of California (Aragon et al., 2005)

- II. This domain can be divided into two zones with different structural styles: the central portion extending orthogonally forming a fault system whose main component is normal NE-SW direction. Delimit part Guaymas basin and south basins Carmen and Farallon. Meanwhile, at the edges of the basins transcurrent displacement much cash is spread across four lateral fault systems: The Trasformes Fault System (SFT) Jaws Trasformes Fault System (SFT) Guaymas Transformes Fault System (SFT) Carmen and Trasformes Fault System (SFT) Farallon. This domain is separated from the north with an angle of  $8^\circ$  with respect to limit Craton and fault system Ballenas, and thus this area functions as an intermediate pivot which accommodates the deformation allowing the domain North has redeemed displacement oblique while at the same time serves as a hub that allows rotation in the South domain of about  $8^\circ$  (Figure 3.8).

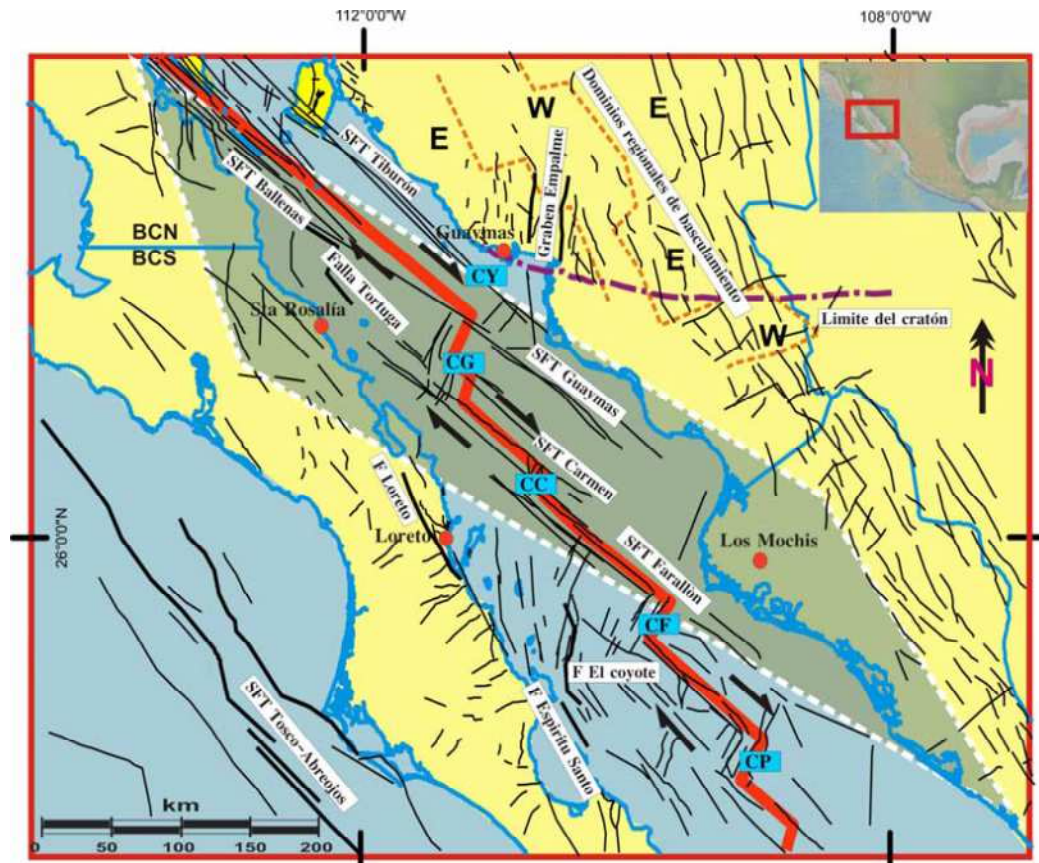

Figure 3.8 Fault system in the central Gulf of California (Aragon et al., 2005)

- III. The South domain partition has a small deformation transpressive extension areas and large transform faults. Unlike the North central domain and sedimentation is almost negligible. Southward transform border becomes a dispersion zone with purely extensional deformation, with a preferred direction NE. In the South domain have four important characteristics: 1) a system of transform faults and extensional basins in the central Gulf, 2) an edge fault system that has different characteristics both in the western part of the North American plate and in the block eastern Baja California, 3) A system of oceanic dispersal in the Pacific dorsal and Rivera with orthogonal extension 4) A fault system located in the ancient subduction zone called Tosco-Abreojos. It can be seen in Figure 3.9 the deformation is accommodated in a system obliquely zigzag lateral faults in systems and extensional. There is a structural variation and from the continental edge faults to the current aperture area.



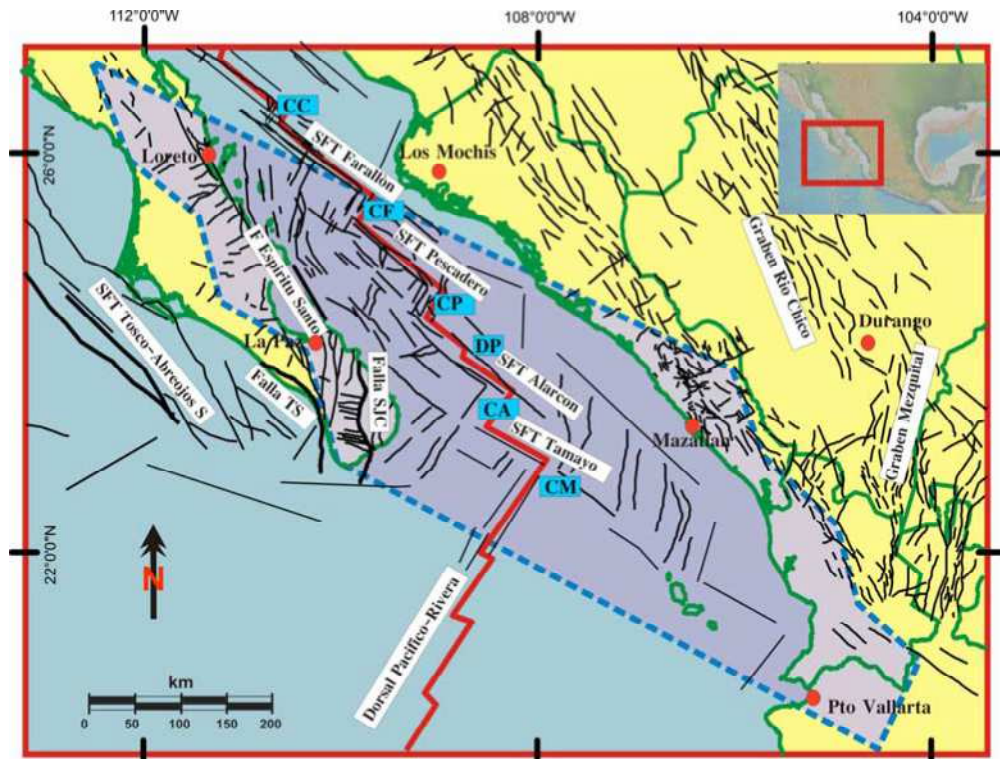

Figure 3.9 Fault system in the central Gulf of California (Aragon et al., 2005)

### 3.3.3 Seismicity

In the Gulf of California there are not accurate studies related to the seismic design spectra. Thus, the seismic characterization of the region is based on the seismic design manual issued by the National Commission of Electricity from Mexico (CFE). From its version 1993 is taken the seismic map where is divide the Mexican territory with curves of equal peak ground acceleration (Figure 3.10). The zone A presents lower intensity while the zone D is the most intense.

In order to use the seismic map, it was necessary the assumption of the next hypothesis:

“The trend of the seismic curves of the different seismic zones are constant even in the sea, thus the peak ground acceleration in the Gulf of California has the same values that the PGA either in the east coast of the Baja California peninsula and the west coast of Mexico”.



Figure 3.10 Seismic regionalization of the Mexican Republic (CFE, 1993)

Once it is analyzed the seismic map of Mexico, is appreciated that the Gulf is surrounded at both coasts with the seismic zone C. Moreover, if is drawing an imaginary line with the same trending from the coast of Acapulco and Puerto Vallarta towards the north, it would be found that match with the border city of Tijuana, and different seismic zone it would be dominant.

Comparing both solutions is preferred to include the Gulf of California in the seismic zone of group D. It is preferable assume the worst scenery which can result more benevolent at the end than a better scenery which result worse at the end. The Figure 3.11 shows the seismic design spectra issued for the CFE in its 1993 handbook.

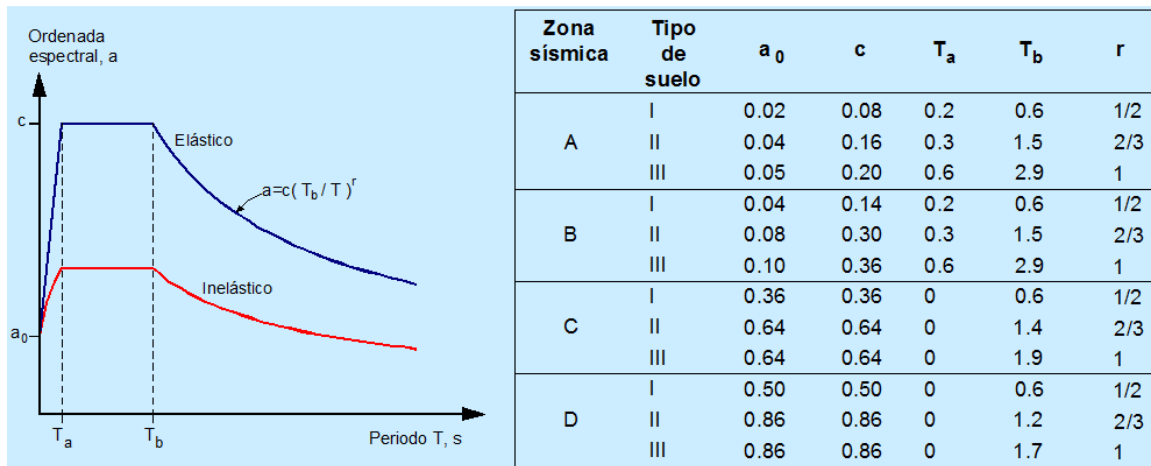

Figure 3.11 Seismic design spectra of Mexico (CFE, 1993)

Thereby is obtained from the seismic design manual of the CFE the seismic design spectra for the zone D. According the type of ground of the Gulf of California which was studied in the section 3.3.1 is considered two type of ground according the classification of the handbook. It the northern gulf due to the marine sediments and the great extensions is considered type II, while in the central and southern gulf can be consider type I due to graves and rock found in the most areas studied. The values of the spectra are summarized in the Table 3.2

<i>Location</i>	$a_o$ (cm/s <sup>2</sup> )	<i>c</i>	$T_a$ (s)	$T_b$ (s)	<i>r</i>
North	0.86	0.86	0	1.2	2/3
Central	0.50	0.50	0	0.6	1/2
South	0.50	0.50	0	0.6	1/2

*Table 3.2 Seismic design spectra of the Gulf of California*

### 3.4 Water temperature

In the Gulf of California are four areas that respond and evolve differently to the seasonal surface heating of the area: a) the northern shallow zone (<30 m depth) of the northern end of the Gulf, b) the northern Gulf, north of the island complex, except for the shallow zone, c) the area of the larger islands that form the insular complex d) the southern central Gulf of large islands and to the Farallon basin. There are three phenomena that have most influence on the increase or decrease of the surface temperature in these areas, the direct heating from the sun, advection, and mixing caused by tides and cold water transports from subsurface to the surface layers.

The study of water temperature in the Gulf is based on data collected by CONABIO<sup>5</sup> through its Ocean Monitoring Satellite System (SATMO). CONABIO in partnership with NASA<sup>6</sup> created images type L1A MODIS where is processed weather information from 2002. For the MODIS (Aqua, Terra) image processing was used SeaDAS software from NASA whose algorithms are based on work done by various groups which are part of the International Ocean-Colour Coordinating Group (IOCCG).

In the present work are analyzed the images that show the monthly average from the July 2002 until June 2011. It is consider that the information in these charts is reliable and significant, once is considered the long period of study as well as the update information. The Figure 3.12 shows the monthly average of the water temperature in the Gulf.

---

<sup>5</sup> Comisión Nacional para el Conocimiento y uso de la Biodiversidad

<sup>6</sup> National Aeronautics and Space Administration

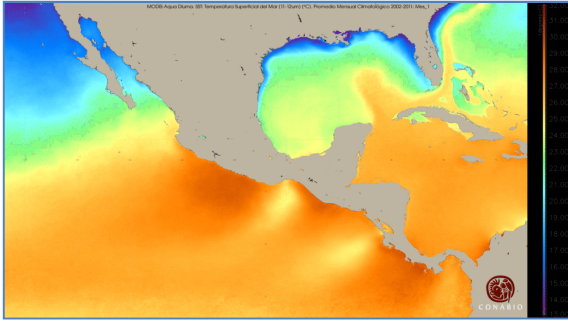

Fig. 3.12(a) Surface Temperature- January

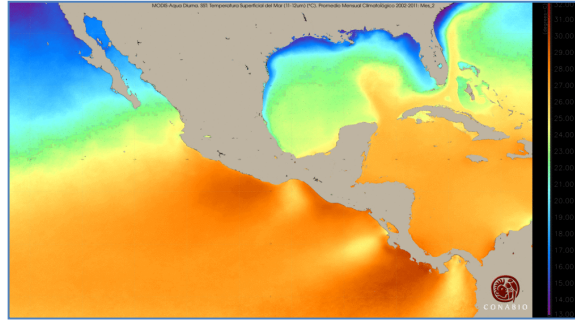

Fig. 3.12(b) Surface Temperature- February

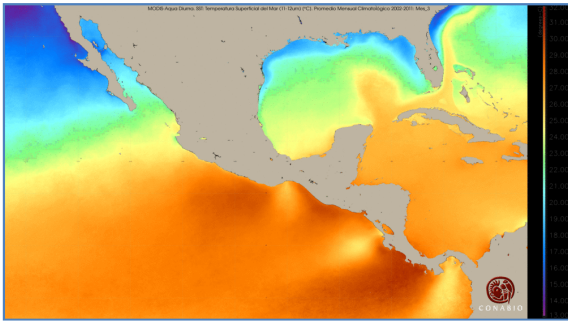

Fig. 3.12(c) Surface Temperature- March

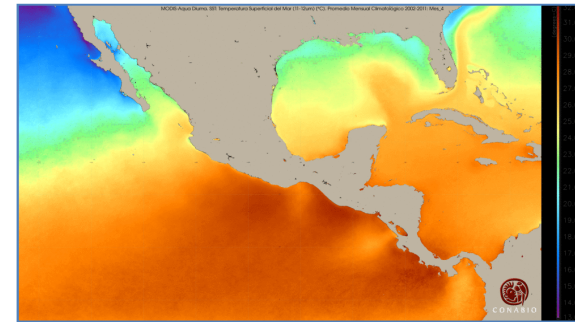

Fig. 3.12(d) Surface Temperature- April

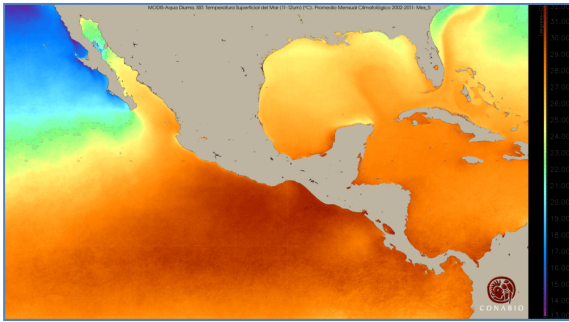

Fig. 3.12(e) Surface Temperature- May

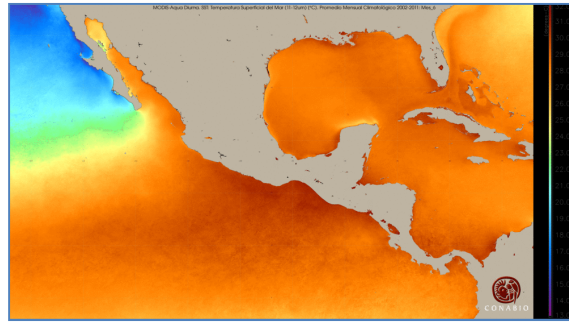

Fig. 3.12(f) Surface Temperature- June

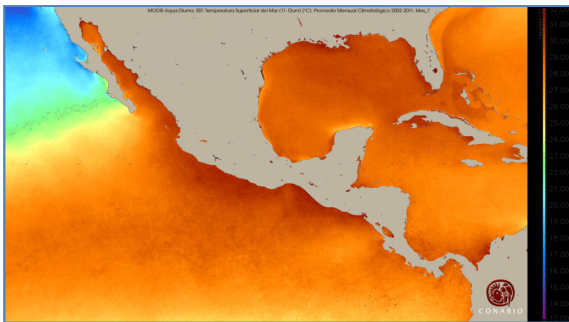

Fig. 3.12(g) Surface Temperature- July

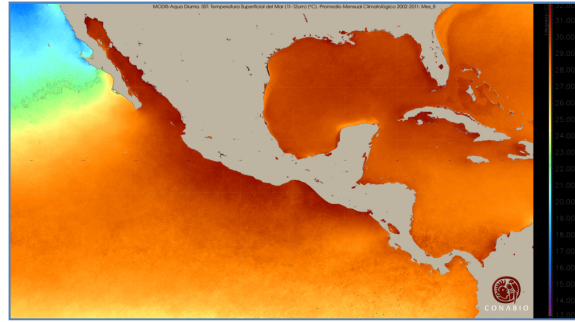

Fig. 3.12(h) Surface Temperature- August

The Figure 3.12 Monthly average of the water temperature in the Gulf of California from 2002 to 2011 (CONABIO)



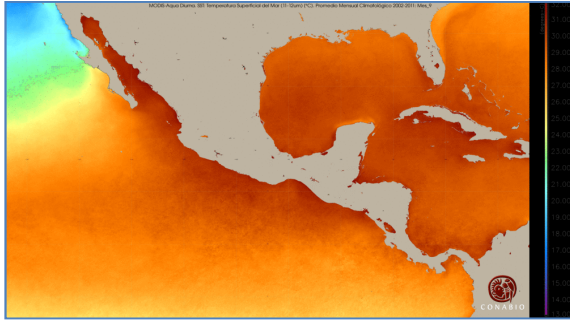

Fig. 3.12(i) Surface Temperature- September

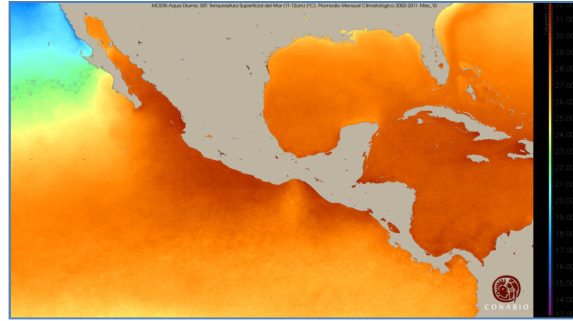

Fig. 3.12(j) Surface Temperature- October

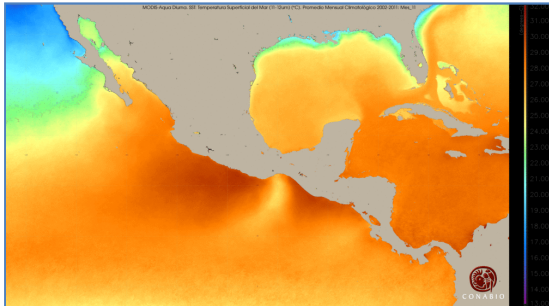

Fig. 3.12(k) Surface Temperature- November

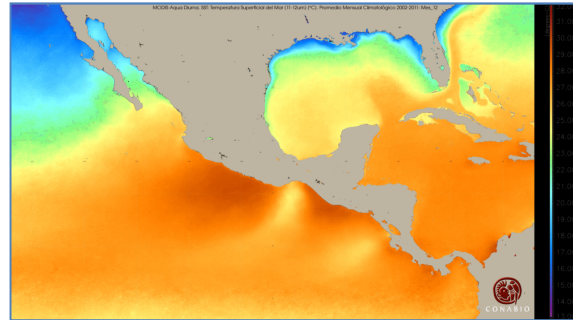

Fig. 3.12(l) Surface Temperature- December

The Figure 3.12 Monthly average of the water temperature in the Gulf of California from 2002 to 2011 (CONABIO, continuation)

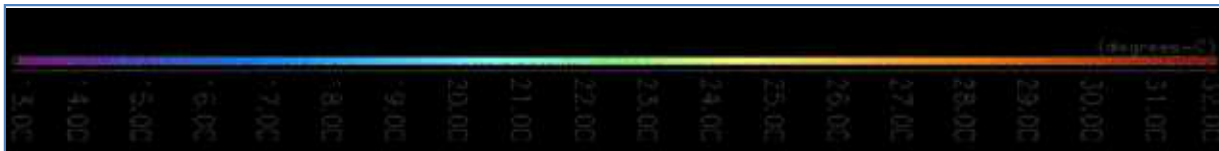

Figure 3.13 Scale in Celsius degrees for the water temperature measurement (CONABIO)

Supported on the scale for measuring the water temperature (Figure 3.13), it is observed that temperature in the Gulf of California has notorious variations according the region as well as the period of year. In the Northern Gulf, average temperatures reach until 10°C in winter while in the summer are about 32°C. Meanwhile in the Central Gulf there is present a strong seasonality in surface temperature, where the lower values are roughly 16°C in the months of February and March (winter) while in August (summer) are around 31°C. In this region of the gulf during the summer the temperature at 150 depth reach values of 16°C (SEMARNAT). Moreover, the temperature variations in the Southern Gulf are smaller its counterparts in central and northern part. The temperature ranges from December to March are about 22°C, with temperature increase for the remaining months of the year in a range of 27-32 ° C.



### 3.5 Winds

The atmospheric circulation in the Gulf of California occurs mainly along the longitudinal axis because of the elevated topography on both sides (Badan-Dangon et al., 1991). Numerical studies on the circulation have been based on the assumption that winds blow more or less symmetrically up (northwest) and down (southeast) the gulf in summer and winter, respectively. Consequently, except for Martínez's (2002) modeling studies using satellite-derived wind data from NSCAT/ERS-2 and the NCEP atmospheric circulation model, most numerical simulations of the gulf's circulation have used a hypothetical wind without considering its spatial variation and assuming a simple annual variation (Marione et al., 2004).

In the Atmospheric Centre of Science of the National Autonomous University of Mexico (UNAM) was created a digital climate atlas of the Mexican republic. In the atlas is shown the monthly average value of surface winds from 1999 until 2006. The data can be consulted in this link:

<http://uniatmos.atmosfera.unam.mx/ACDM/>

The Figures 2.14a to 2.14l shown the maps displayed in the digital climate atlas of each month.

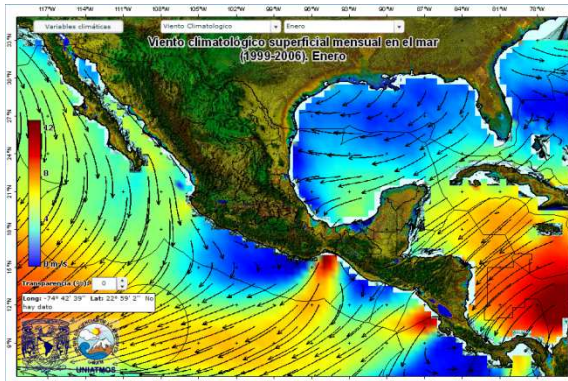

Fig. 3.14(a). Surface winds- January

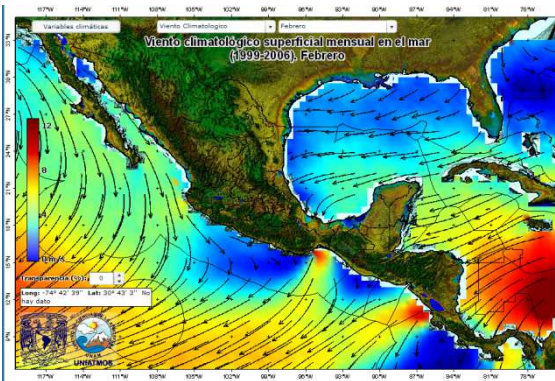

Fig. 3.14(b). Surface winds- February

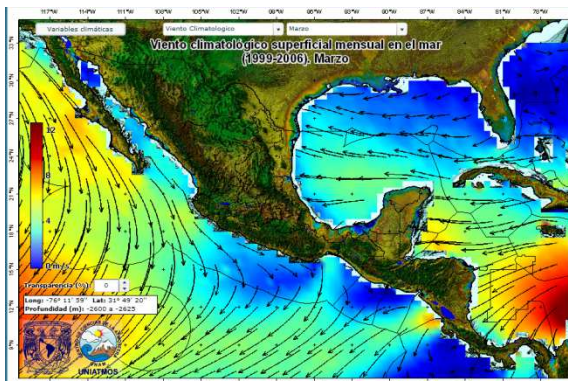

Fig. 3.14(c). Surface winds- March

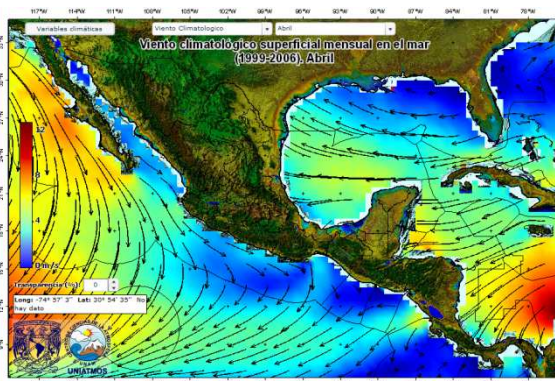

Fig. 3.14(d). Surface winds- April

*The Figure 3.14 Monthly average of the surface winds in the Gulf of California from 1999 to 2006 (CCA, UNAM)*



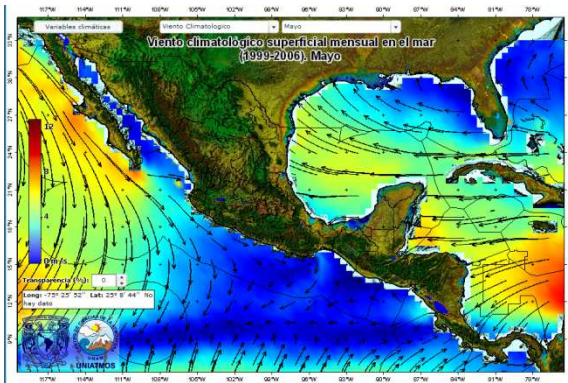

Fig. 3.14(e). Surface winds- May

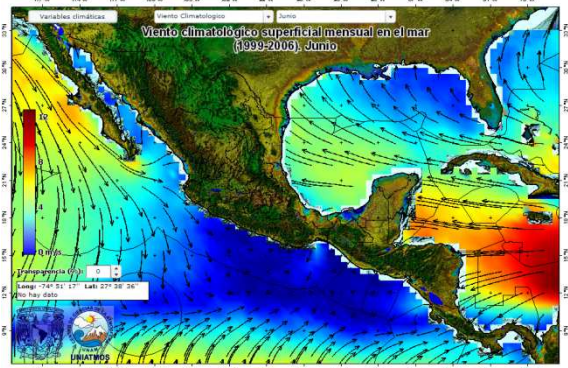

Fig. 3.14(f). Surface winds- June

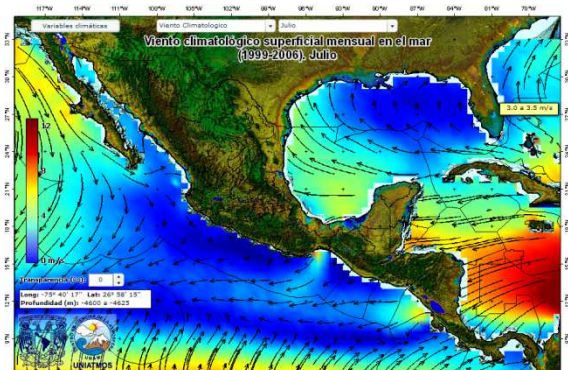

Fig. 3.14(g). Surface winds- July

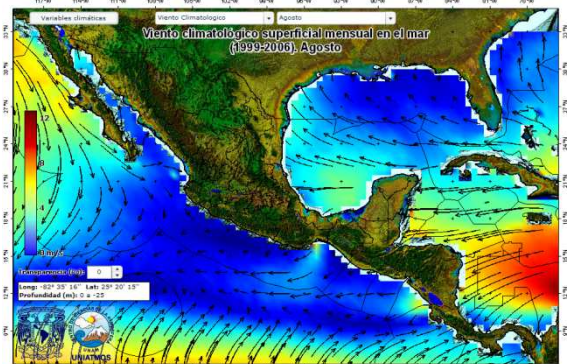

Fig. 3.14(h). Surface winds- August



Fig. 3.14(i). Surface winds- September

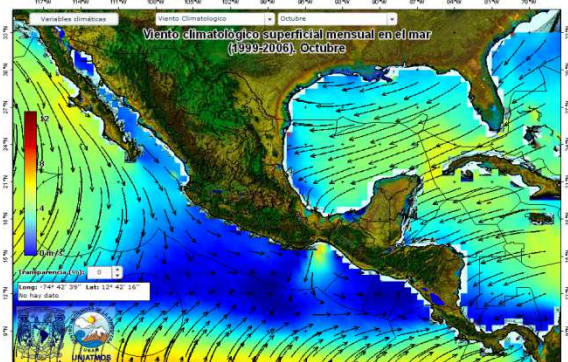

Fig. 3.14(j). Surface winds- October

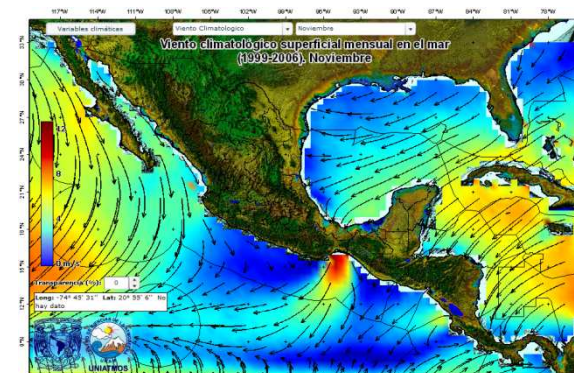

Fig. 3.14(k). Surface winds- November

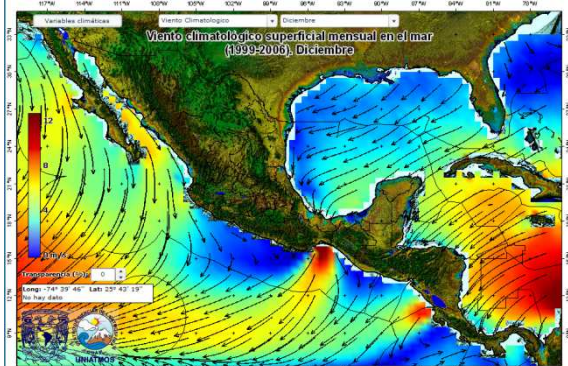

Fig. 3.14(l). Surface winds- December

The Figure 3.14 Monthly average of the surface winds in the Gulf of California from 1999 to 2006 (CCA, UNAM, continuation)

The winds in the Gulf of California have different variations along its extension as well as the season of the year.

The maximum values of the wind magnitude are presented during the winter, when the wind circulation has southeast direction. The highest values of the wind velocity are during December and January reaching magnitudes of almost 6.8 m/s in the mouth of the Gulf. During this season the velocity is constant from the southern part to the central gulf vary between 6 and 6.8 m/s in the same direction. In the central gulf near to the island complex the magnitude decrease abruptly and measurement of the winds are between 2.30 m/s in the northern part and 3.5 m/s in the south follow the same direction. Furthermore, in the northern part of the gulf the wind velocity increase being the maximum magnitudes about 4.5 m/s

On the other hand, during the summer the winds circle in northwest direction. The values are almost constant in the whole gulf with a range between 2.3 a 3.5 m/s. Opposite to the winter, the maximum values are presented in the northern part, reaching velocities of 3.5 m/s. The magnitudes decrease in the central part until 2.8 m/s, while in the southern part of the gulf the measurement has data of 2.3 m/s with a northwest direction.

### 3.6 Currents

One of the most important parts of the study of the environmental condition for a waterway crossing is the study of currents. Currents impact directly in the structures under the water, thus an appropriate study must be carried out. The magnitudes of velocity as well as the direction are the main data that have to be collected. In addition, is important to know the variation of the velocity at different depths.

In a SFT the currents impact straight to the structure thus the hydrodynamic behavior depends of the magnitude and direction of these actions.

Circulation in the gulf is produced in order of importance by (Jimenez et al.):

- a. Pacific Ocean forcing (low frequencies and tides)
- b. Sea surface winds.
- c. Surface heat and water fluxes.

From an oceanographic point of view, one of the most important characteristics of atmospheric circulation is the spatial variability, which generates atmospheric vorticity that is transferred to the sea by turbulent momentum fluxes capable of creating turbulence and gyres in the water column (Parés-Sierra et al., 2003).

It is traditionally considered that in summer, outflow of gulf water occurs along the coast of the Baja California peninsula and ocean water penetrates along the coast of the mainland, and that in winter, the situation is reversed (e.g., Bray, 1988a; Beier, 1997). Castro et al. (2000) reported that the water exchange at the mouth occurs via cyclonic circulation in spring, fall and winter. Most numerical models reproduce the following surface circulation characteristics: generally cyclonic in summer and anticyclonic in winter, with an expressed gyre in the northern part of the gulf and alongshore flows in the southern part (Makarov et al., 2002).

Due to complexity of the circulation variation in the Gulf of California and the many factors that are involved, for the present work is decided to take in account the geostrophic currents. The accuracy require for this work, being a preliminary design is deepened enough consider this type of currents. Therefore, this work is based on the digital climate atlas created by the Atmospheric Centre of Science of UNAM. The material issued shown the monthly average values of geostrophic currents from 1993 until 2012. The charts shown in the Figure 3.15(a) to 2.15(l) show the circulation and the magnitude along the gulf.



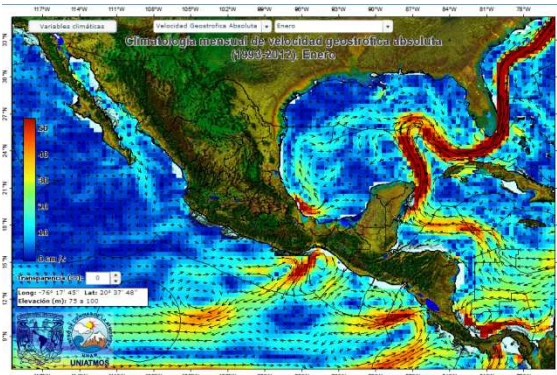

Fig. 3.15(a) Geostrophic currents – January

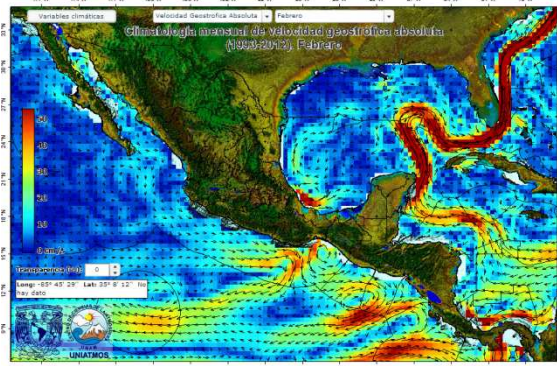

Fig. 3.15(b) Geostrophic currents - February

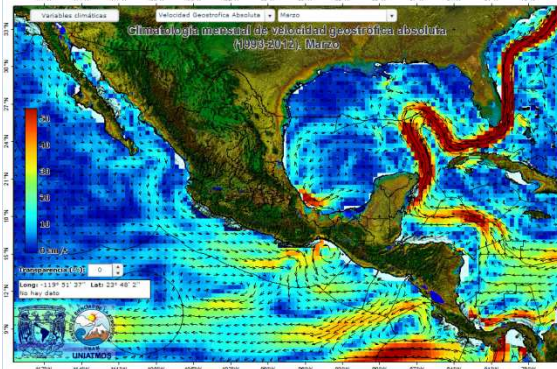

Fig. 3.15(c) Geostrophic currents – March

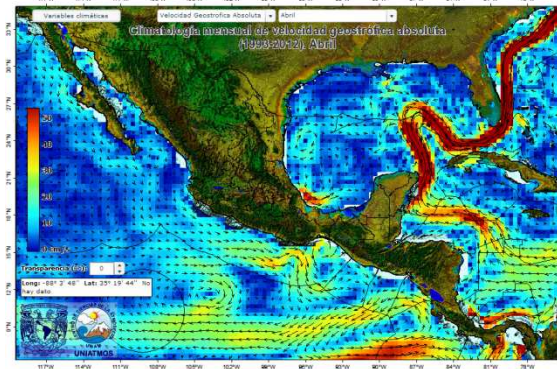

Fig. 3.15(d) Geostrophic currents - April

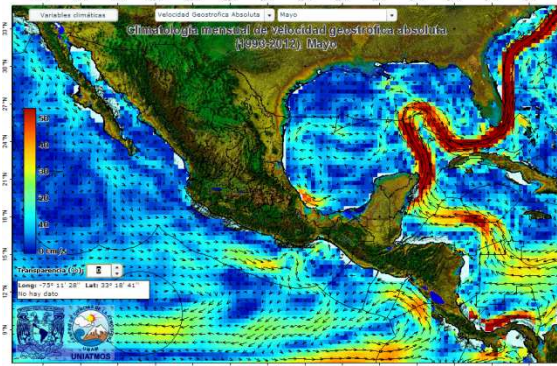

Fig. 3.15(e) Geostrophic currents – May

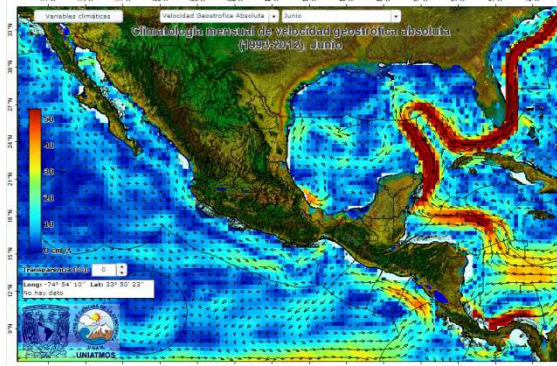

Fig. 3.15(f) Geostrophic currents - June

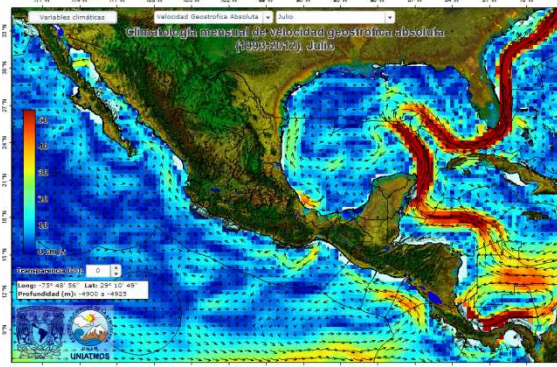

Fig. 3.15(g) Geostrophic currents – July

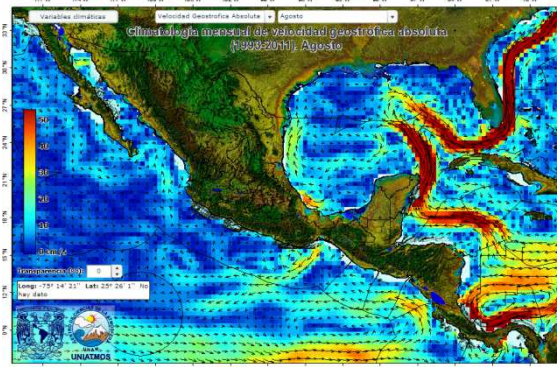

Fig. 3.15(h) Geostrophic currents - August

The Figure 3.15 Monthly average of the geostrophic currents in the Gulf of California from 1993 to 2012 (CCA, UNAM)



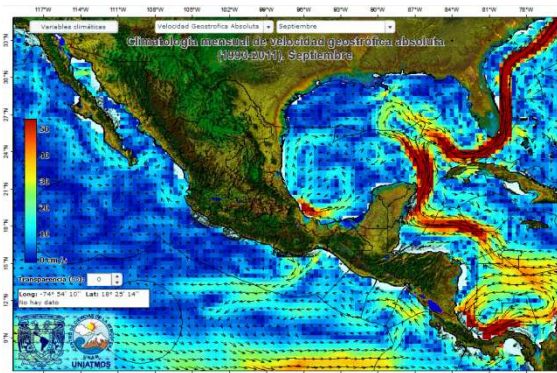

Fig. 3.15(i) Geostrophic currents –September

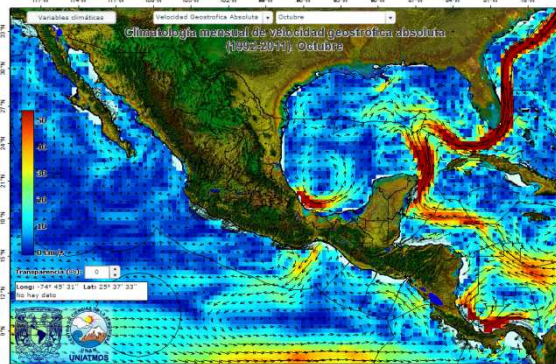

Fig. 3.15(j) Geostrophic currents - October

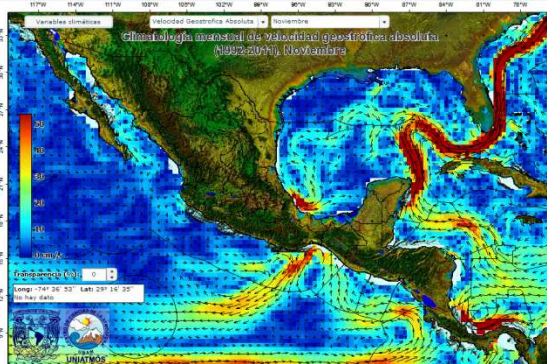

Fig. 3.15(k) Geostrophic currents – November

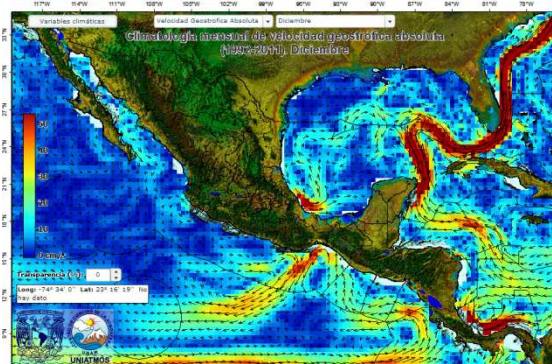

Fig. 3.15(l) Geostrophic currents - December

*The Figure 3.15 Monthly average of the geostrophic currents in the Gulf of California from 1993 to 2012 (CCA, UNAM, continuation)*

The currents variation along the year are similar either in direction and location of the maximum measures. During the summer the currents have their maximum values in their northern part of the gulf, reaching magnitudes of 28 cm/s near of the mouth of Colorado river. Towards the central gulf the values decrease considerably, founding values between 12 cm/s and 18 cm/s near of the island complex. Moreover, the minimum values during the summer are presented in the southern gulf where can be found measure from 8cm/s to 12 cm/s near of the mouth.

During the winter the currente velocity are more regular along the gulf. In the northern gulf the velocity rounds between 6 cm/s and 10 cm/s. The minium values are presented in the norhtern part of the island complex where can be found magnitud until 4 cm/s, while in the south part of these islands velocities reach the 12 cm/s. The maximum values of the season are located in the southern gulf at the northeast of the La Paz city, where values until 18 cm/s can be found.

It is important to note that the current magnitudes explained here before, is the overview of the gulf of california, thus an accuracy study is carry out in the location of the SFT.

### 3.7 Tides

The Gulf of California is a semi-enclosed sea thus tides have a large amplitude mainly in the northern part. In the Gulf are predominant semidiurnal tides, two high tides and two low within 24 hours. The tides in the northern Gulf are among the highest in the world: in the mouth of the Colorado River fluctuations have been measured more than nine meters (SEMARNAT). This large vertical displacement of water creates enormous intertidal areas with up to 5 km of extension which generates strong tidal currents and small waves. The tidal range in the Central Gulf is lower than in the northern part of the gulf, with an average of 1.5 m, while in the southern part or mouth of the gulf, the tidal range is about 1 m.

The collection of data has been based on the information provided by the Center for Scientific Research and Higher Education of Ensenada (CICESE<sup>7</sup>), as well as the National Oceanographic Service of the Geophysics Institute from UNAM. The CICESE has a network for monitoring sea level, based on information collected from various measure stations in the coast of the peninsula of Baja California. On the other hand, the network of UNAM has measure stations along the coasts of the Mexican republic. Each measure station provides data of the tides during normal conditions as wells as the maximum historical tides presented during extraordinary events.

In the Figure 3.16 can be appreciate the measure stations located in the coast of Mexico. The stations of interest for the present work are the located in the Gulf of California.

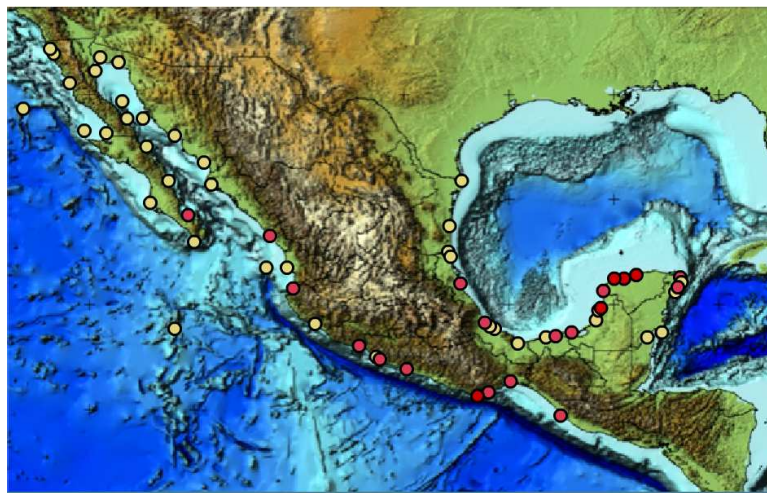

Figure 3.16 Location of the oceanographic stations in the coast of Mexico (IG, UNAM)

The oceanographic stations of particularly interest for the present work are: Bahía de Los Angeles, Santa Rosalia, Loreto, La Paz, Cabo San Lucas, Guaymas, Topolobampo and Yavaros. The data collected was basically the variation of the sea level during the normal conditions as wells as the maximum measures in case of extraordinary events since 1970.

In the Table 3.3 is summarized the obtained data of the selected oceanographic stations.

---

<sup>7</sup> Centro de Investigación Científica y de Educación Superior de Ensenada

Station	Location	Mean High Higher Water (m)	Mean Lower Low Water (m)	Maximum Mean High Higher Water (m)	Minimum Mean Lower Low Water (m)	Amplitude of maximum tide (m)
San Felipe, B.C.	31°01' N 114°49' O	2.096	-2.019	3.827	-3.122	6.949
Bahia de Los Angeles, B.C.S.	28°57'N 113°33'O	0.990	-1.018	1.847	-1.932	3.779
Santa Rosalia, B.C.S.	27°20'N 112°15'O	0.143	-0.395	0.684	-0.901	1.585
Loreto, B.C.S.	26°0.9'N 111°20.4'O	0.374	-0.442	0.746	-0.900	1.646
La Paz, B.C.S.	24°16'N 110°20'O	1.024	-0.536	1.329	-0.987	2.316
Cabo San Lucas, B.C.S.	22°53'N 109°54'O	0.585	-0.609	1.095	-1.099	2.194
Puerto Peñasco, Son.	31°18'N 113°33'O	2.148	-2.139	3.829	-3.249	7.078
Guaymas, Son.	27°55.3'N 110°53'O	0.357	-0.474	0.854	-1.188	2.042
Yavaros, Son.	26°42.3'N 109°30.5'O	0.463	-0.572	0.884	-1.219	2.103
Topolobampo, Sin.	25°35.2'N 109°3.4'O	0.528	-0.610	1.149	-1.228	2.377
Mazatlan, Sin.	23°10.9'N 106°25.4'O	1.127	-0.616	1.462	-1.250	2.712

*Table 3.3 Sea level of the oceanographic stations in the Gulf of California*

### 3.8 Waves

In oceans there are two types of waves, wind waves and swell waves. Wind waves result of the wind blowing over a vast enough stretch of water surface. When is directly generated and affected by local winds, wind wave system is called wind sea. On the other hand, swell waves consists of wind-generated waves that are not affected by the local wind at that time. They have been generated elsewhere or some time ago (Holthuijsen, 2007).

The wave features of interest for the preliminary design of Submerged Floating Tunnel of this work are: the maximum wave height, period and its length, within the possible locations of the structure.

The analysis of the wave data is based on the work done by Rivillas (2008), which analyzes the generated waves in the Mexican coast during the period 1948 to 2007. It the work presents the maximum values of height for different return period. Rivillas used the spectral wave model of third generation called Wave Model (WAM) to develop numerical models and reanalyze the data in order to generate maps of the sea state. The maps generated are either in the Pacific Ocean and the Atlantic Ocean.



From Rivillas's work is analyzed the wave height map for a return period of 100 years. It is considered that a hundred years is a rational value for the SFT design which usually marine structures consider this value as life time period. It can be appreciate in Figure 3.17 a wide variation in the values during the different seasons of the year, due to the influence of the wind and its magnitude and direction changes throughout the year. The maximum values are presented during the summer and fall with heights of 13 m in the southern part of the gulf. Moreover, in the winter the values are about 1 m in the northern gulf being the minimum value recorded. During this season the wave heights are lower, with variation from 1-3 meters along the entire Gulf. For the spring season the heights tend to increase considerably in the southern part of the Gulf, reaching heights up to 9 m. Moreover, the maximum wave heights are presented during the summer and fall months, slightly higher during the first season, having faced maximum height of 12 meters in the mouth of the gulf. In the central part the values are lower with heights from 8 to 10 in the central part, while in the northern gulf the values are minimum of about 7 m.

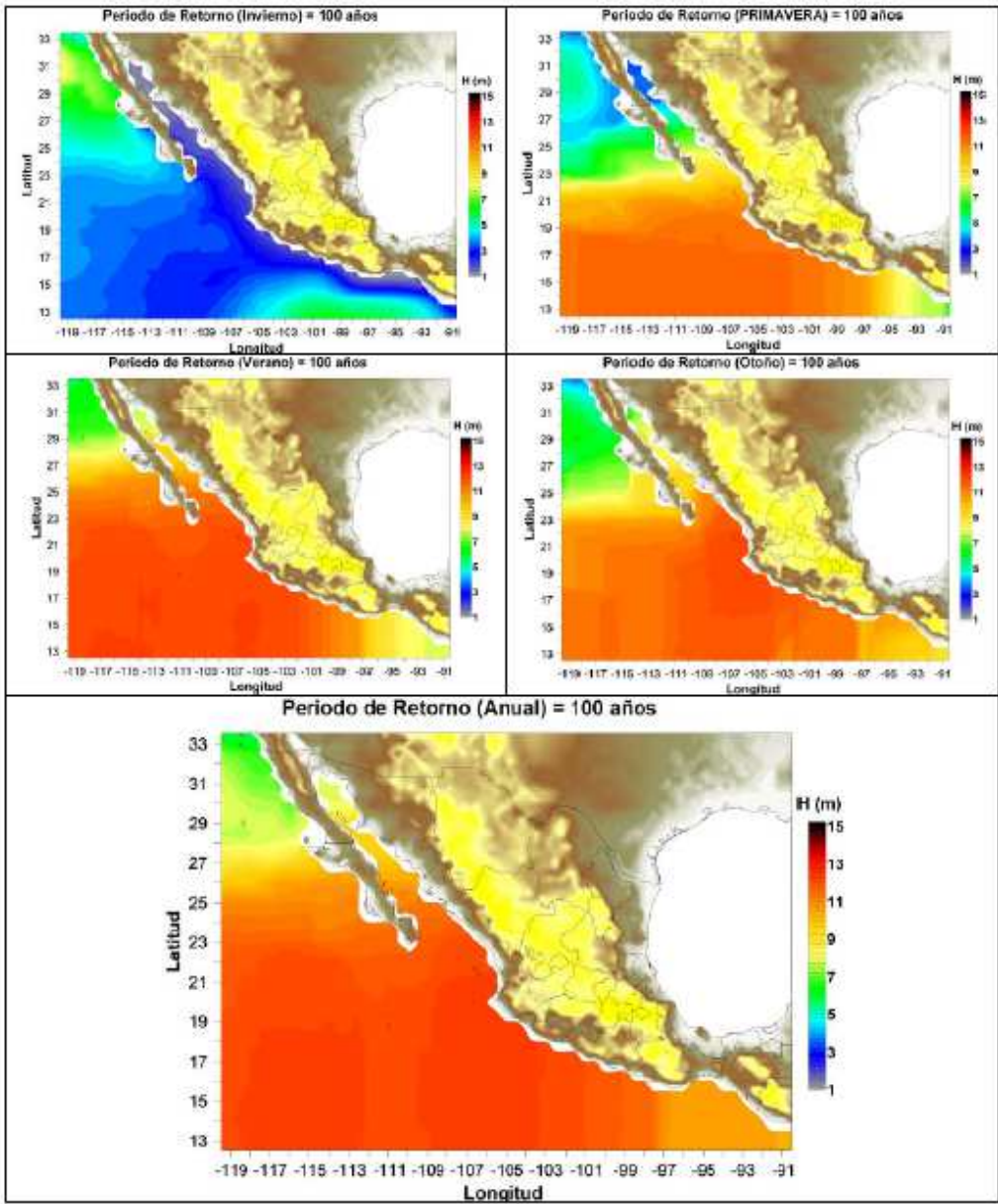

Figure 3.17 Wave height maps in a return period of 100 years (Rivillas, 2008)



### 3.9 Meteorological Phenomena

The presence of meteorological phenomena such as hurricanes, tsunamis, earthquakes, changes the normal conditions of the regional environment. Thus, during the design step of any marine structure has to be taken account some marine features as sea levels, winds, waves under supernatural phenomena.

Rivillas (2008) analyzed the characteristics of the Pacific Ocean under extreme conditions. Maps of maximum historical wave height and its associated period are taken from the study (Figure 3.18).

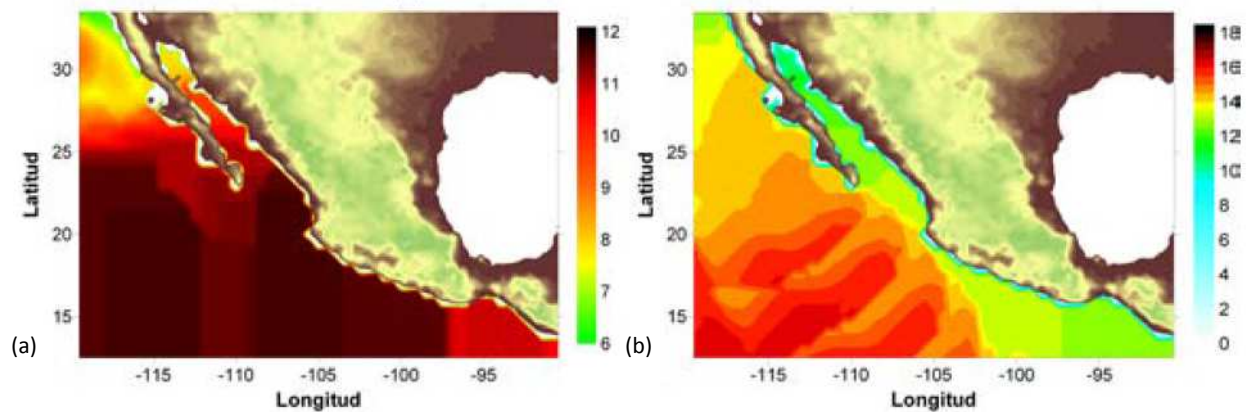

Figure 3.18 Maps of: (a) maximum historical wave height; (b) Period of maximum historical wave height (Rivillas, 2008)

As under normal condition the maximum values of the wave height are presented in the mouth of the Gulf reaching magnitudes 12 meters with periods of 12 seconds. In the central Gulf wave height reaches the 10 meters with periods of up to 10 seconds, while in the northern Gulf wave heights are about 8 meters associated with a period of 10 seconds. It can be appreciated that the magnitudes are similar as the wave heights for a return period of a hundred years. Thus, the worse condition must be taken as design values. The study of the wind under extreme conditions is based on Rivillas study (2008). It is analyzed the map of winds for a return period of 100 years (Figure 3.19).

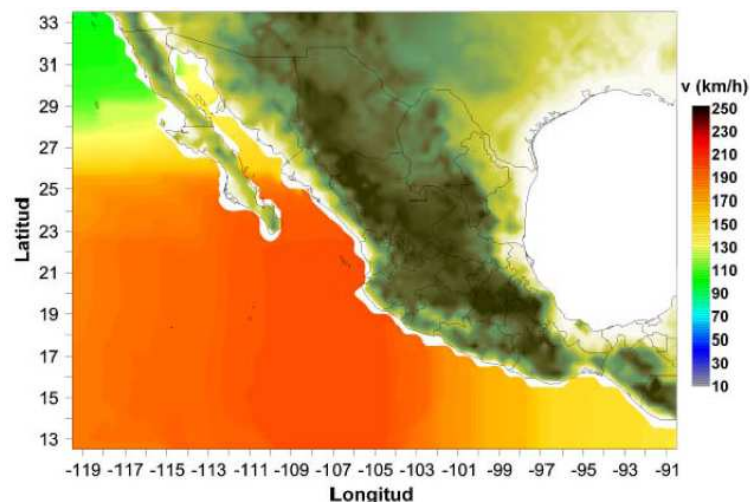

Figure 3.19 Map of winds for a return period of 100 years (Rivillas, 2008)

It can be appreciated that the maximum values are presented in the southern gulf where the wind values reach a velocity of 210 km/h. In the most of the gulf the velocity values are roughly 150 km/h. The minimum values are around 110 km/h located in the northern gulf.

### 3.10 Shipping in the Gulf of California

The vessels in the Gulf of California are very diverse throughout this. Get accurate data on the characteristics of the boat is really important to the design of a Submerged Floating Tunnel in order to provide the clearance required for the free passage. The SFT must be place in a depth enough to avoid any collision from the surface.

The collection of the shipping data is based on data from official drafts of the ports in the Gulf of California issued by the Secretariat of Communications and Transportation from Mexico (SCT). In addition some information is collected from Port Authority of Baja California Sur (APIBCS). In the Figure 3.20 can be appreciated the official ports located in the Gulf of California.



Figure 3.20 Official ports located in the Gulf of California (SCT)

Once located the ports in the Gulf of California is collected information of the draft of the ports. In the Table 3.4 is summarized the draft of each ports and its location in the Mexican state.

Port Name	Mexican State	Draft (m)
La paz	Baja California Sur	4.50
Puerto Escondido	Baja California Sur	8.00
Loreto	Baja California Sur	3.10
Santa Rosalia	Baja California Sur	8.00
Mazatlan	Sinaloa	12.19
Topolobampo	Sinaloa	12.80
Yavaros	Sonora	6.70
Guaymas	Sonora	13.71
Bahia de Kino	Sonora	6.00
Puerto Libertad	Sonora	13.71
Puerto Penasco	Sonora	4.00
Golfo de Santa Clara	Sonora	7.00

Table 3.4 Draft of the ports located in the Gulf of California

### 3.11 Natural Protected Areas

All projects have to consider the environmental impact that would occur during and after its execution. The fact is that this impact has to be reduced as much as possible. The Submerged Floating Tunnels as a crossing solution represents an advantage since the environmental point of view. It can be considered as an invisible structure from the surface, thus it would not affect the landscape around.

The case of the Gulf of California is really a challenge on environmental issues since the islands from the central part were declared a World Heritage Site in its category of natural, under the name of Islands and Protected Areas of the Gulf of Baja California. In addition to the islands, it must be considered the abundant wildlife and marine life that exists in this sea. Thus, the design of the SFT in the Gulf of California has as initial limits the Natural Protected Areas.

In Mexico exist a government department that is responsible for regulating and protecting these areas. The National Commission of Natural Protected Areas (CONANP) is the government institution which regulates these areas. This commission issued a map where are defined all protected natural areas in the country in each government level. The Figure 3.21 shows the map issued by CONANP.



Figure 3.21 Map of the Natural Protected Areas of Mexico (CONANP)

For this work is required the Natural Protected Areas in the Gulf of California. In the Figure 3.22 can be appreciated the limits of the possible location of the Gulf of California. In central part of the Gulf are the most of the natural reserves, mainly the islands and its and their surroundings.



Figure 3.22 Natural Protected Areas of the Gulf of California (CONANP)

## Chapter 4

### Conceptual design of the SFT in the Gulf of California

A Submerged Floating Tunnel is not just a single floating structure in the water. It consists in a group of elements that give as a result a waterway crossing solution. The present design has considered the main issues that a SFT require for achieving its purpose. In addition, due to the great length of the crossing which is considerably longer than current tunnels around the world, extra considerations has been evaluated in order to met the safety requirement of tunnels. Furthermore, some improvements of tunnel technology are taken in account for adapting for this proposal. In the Figure 4.1 are schematized the elements of the SFT of the Gulf of California which are aboard for their design.

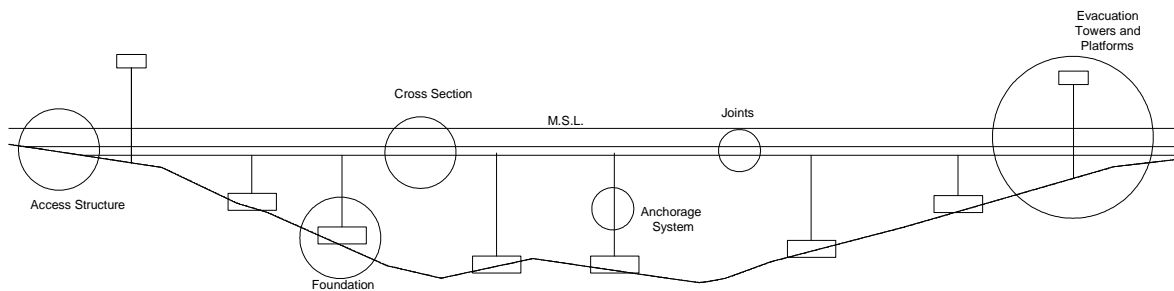

Figure 4.1 Issues object of design of the SFT of the Gulf of California

It must be note that the SFT proposed in the work is anchored on the seabed, due to the extreme natural conditions in the gulf studied in section 3. In addition two towers are implemented placed at different positions along the crossing. These structures which would improve the safety of the tunnel since the evacuation points are shorter. All details of the different issues are design in the section 4.3 of this work.

#### 4.1. Location of the SFT

The Gulf of California is located in the northwest of Mexico. It is an extension of the Pacific Ocean surrounded at the east by the states of Sinaloa and Sonora, while in the other side girded for the peninsula of Baja California. The sea surface has a total area of 247,000 km<sup>2</sup>. It has a length of 1500 km and variable width between 92 and 222 km. In addition, the depth at the southern part reaches values of around 3000 m. In the figure 4.2 is shown the location of the Gulf of California.

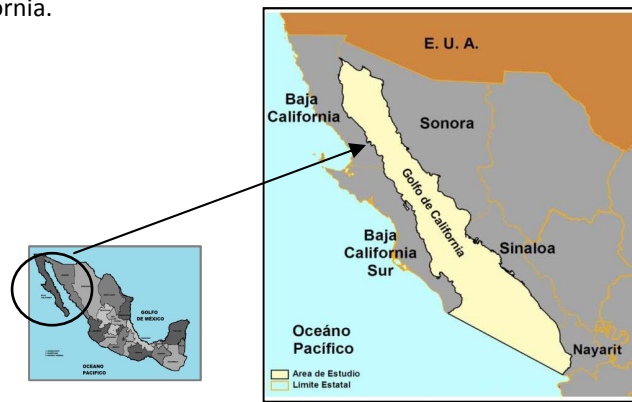

Figure 4.2 Location of the Gulf of California (SEMARNAT)

Details and generalities of the physics and environmental conditions of the Gulf of California can be consulted in the chapter 3 this work.

The Gulf of California is a huge marine area and the conditions are notoriously different. The condition in the southern part has many variations with respect to the middle or the northern part. Furthermore, these changes are really notorious during the season of the year.

Thereby, the criteria for the evaluation are established in order to limit the suitable zones for the Submerged Floating Tunnel location.

#### 4.1.1. Selection Criteria

The criteria for the SFT location are governed by many factors based on the structural configuration choice. The main task is achieved the structural safety of the tube. In addition, the feasibility of the project must ensure the real benefit if the project would be executed.

The selection criteria are listed here below:

- The depth for the location must be no larger than 400 m in order to ensure the lateral stiffness for the structure as well as stability along the SFT.
- The structure has to be located as much as possible in the southern part for the Gulf of California, it being the mouth of the gulf the ideal position.
- The environmental conditions are quite severe, for this reason could not be used pontoons at the surface as a fixed system.
- In order to dismiss the environmental impact for the structure, it was avoided crossing for natural reserved areas, considering that on the Gulf of California these zones are presented in many cases.

The first point has priority over the others. If the remaining points are achieved the location could not be acceptable if the depth criterion is not met. Therefore, the establishment is an interactive process where the goal is to achieve all the points.

Thus, the first step was to create seabed sections for later analyze them in order to limit the zones where the SFT could be placed.

#### 4.1.2. Seabed sections

In order to obtain the profiles at the seabed, it was required to have the bathymetry in the whole gulf. This data is based on the navigation charts published by the Navy of Mexico. In addition, it was necessary to use a complement for the software *AutoCAD 2011*, called *CivilCad2011*. The data of the depth points were introduced on the software, for obtaining a grid of the bathymetry in the whole gulf. Once the grid was formed, it was possible to draw sections in any part of the gulf as well as any orientation. These sections present as results the length and the depth at any point.

##### 4.1.2.1. Longitudinal sections

As the Gulf of California, it is a huge area where the location of the SFT has several possible sites it was decided to limit these locations drawing longitudinal sections from the northern to the southern part. These sections were evaluated with details in order to meet the established criteria. The figure 4.3 shows the longitudinal sections that were found. The location of the longitudinal section can be appreciated in the figure 4.4.

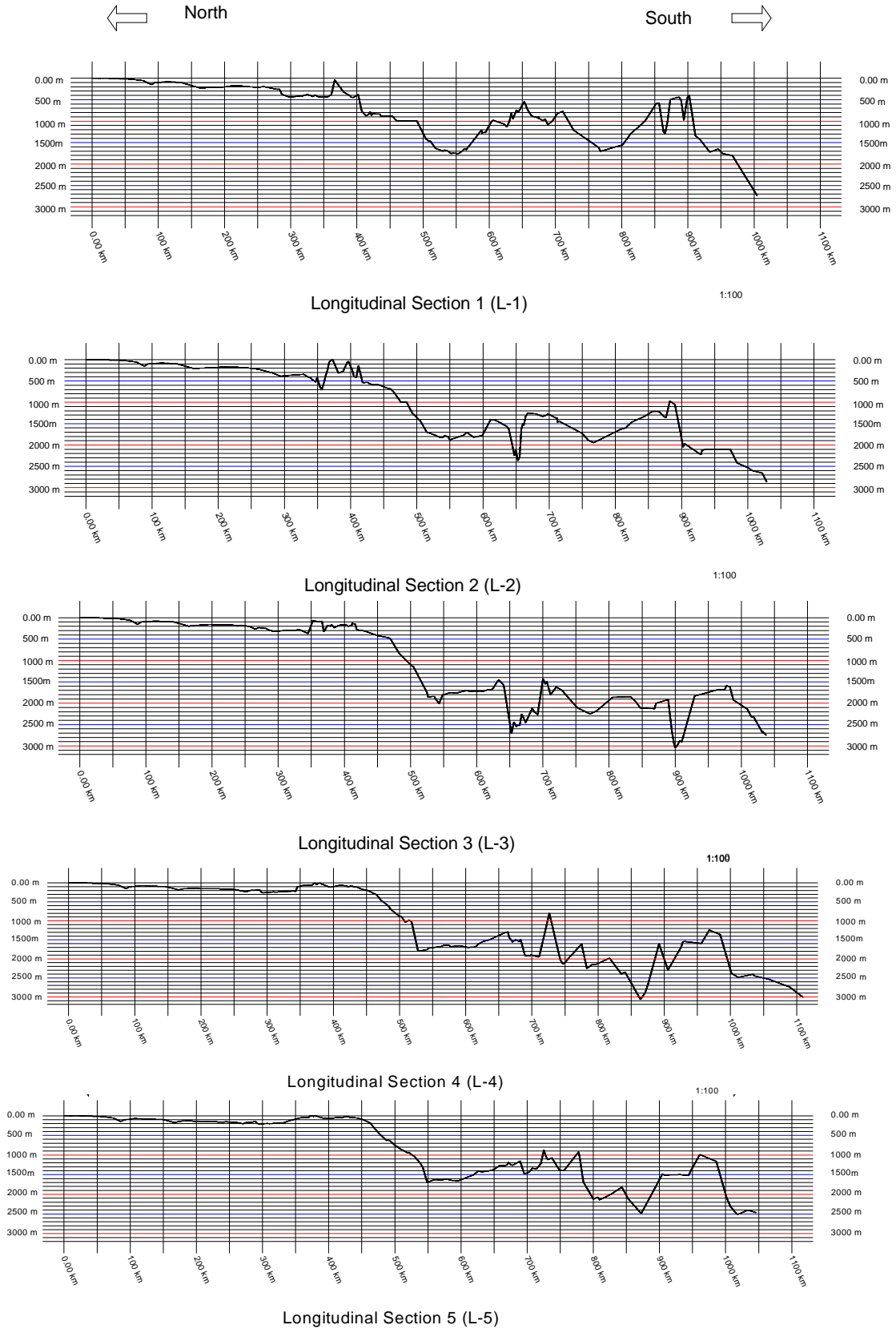

Figure 4.3 Longitudinal Sections in the Gulf of California



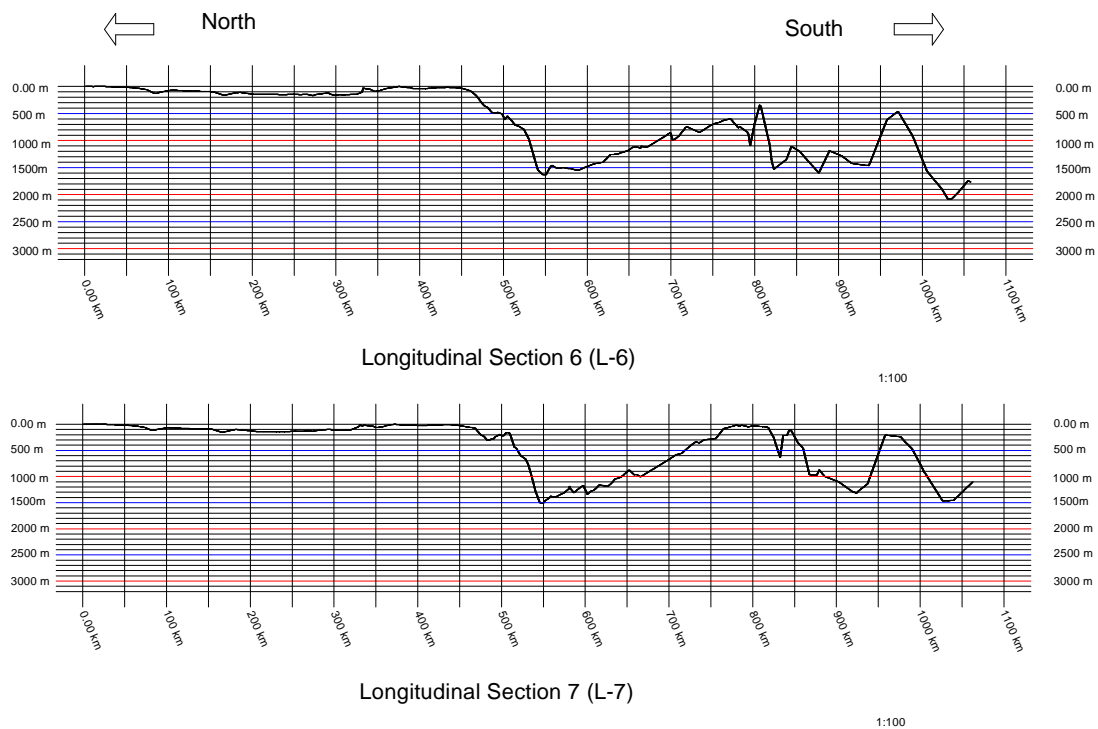

Figure 4.3 Longitudinal Sections in the Gulf of California (continuation)

Follow the depth criterion, from the Figure 4.3 it is clear that the ideal location is in the middle and northern part of the gulf. In almost all the cases, the depth from the kilometer 0 until kilometer 500 is minor than 400m. Just in the section L-1 after the km 400 the depth overpasses the 400 meters. Searching in the southern part, another suitable possibility seems to be at the km 900, but unfortunately in the centered sections L-2, L-3, L-4 and L-5 the values of depths reach more than 1500m depth. Moreover, at the km 800 of sections L-6 and L-7 the depth is within the rate and could be linked with the western section L-1 if an adequate way is found.

Thereby it is necessary drawing transversal section in the Gulf of California in order to discard the possible solutions.

#### 4.1.2.2. Transversal sections

Once the longitudinal seabed profile were analyzed, it was limited the region where the SFT could be placed. Thus, transversal sections were obtained in some strategic points limited for the longitudinal sections. The location of sections can be appreciated in Figure 4.4. Oh the other hand, the Figure 4.5 shows the results of the transversal sections with the assigned code referenced from the Figure 4.4.

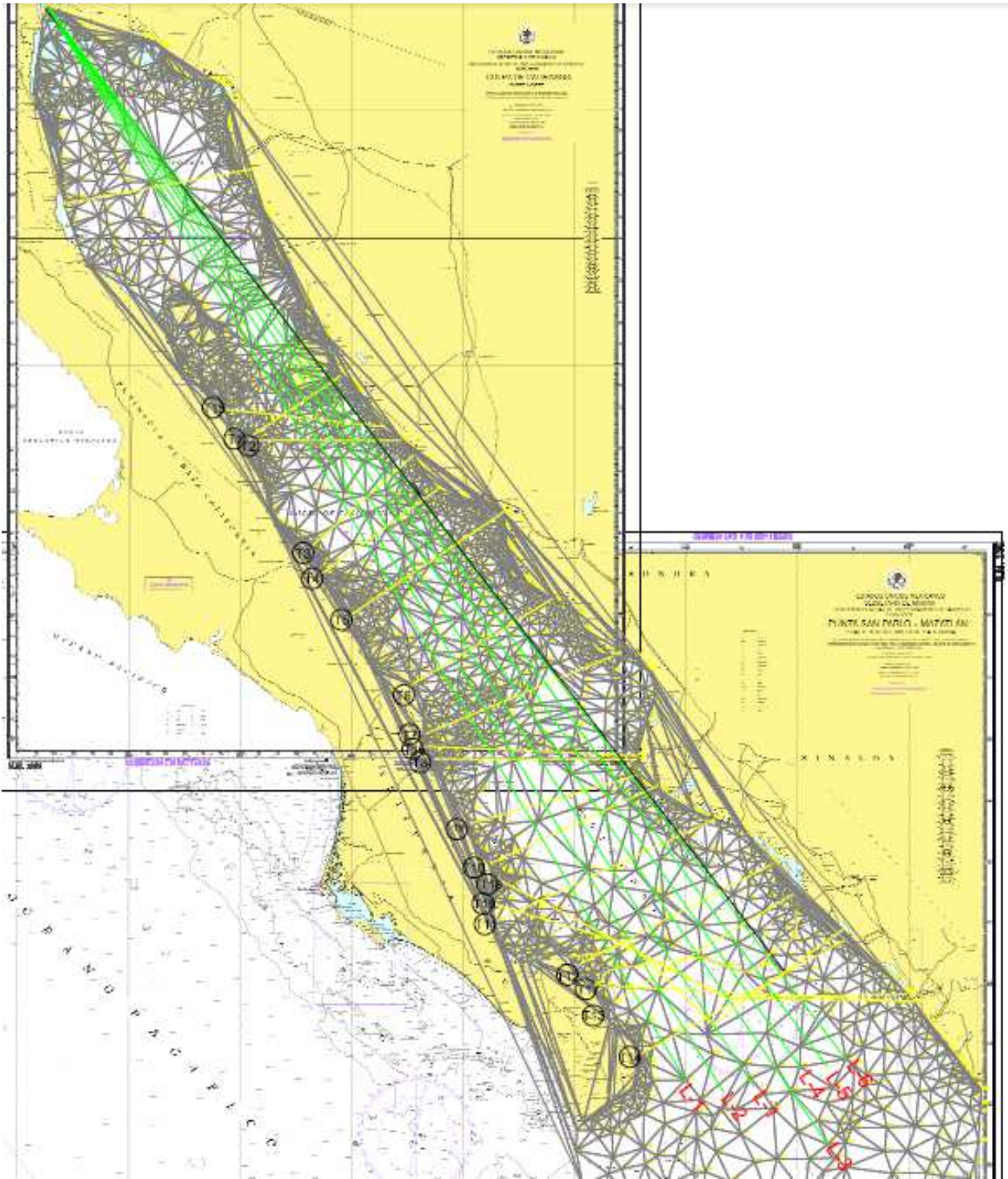

Figure 4.4 Location of the longitudinal and transversal section in the Gulf of California

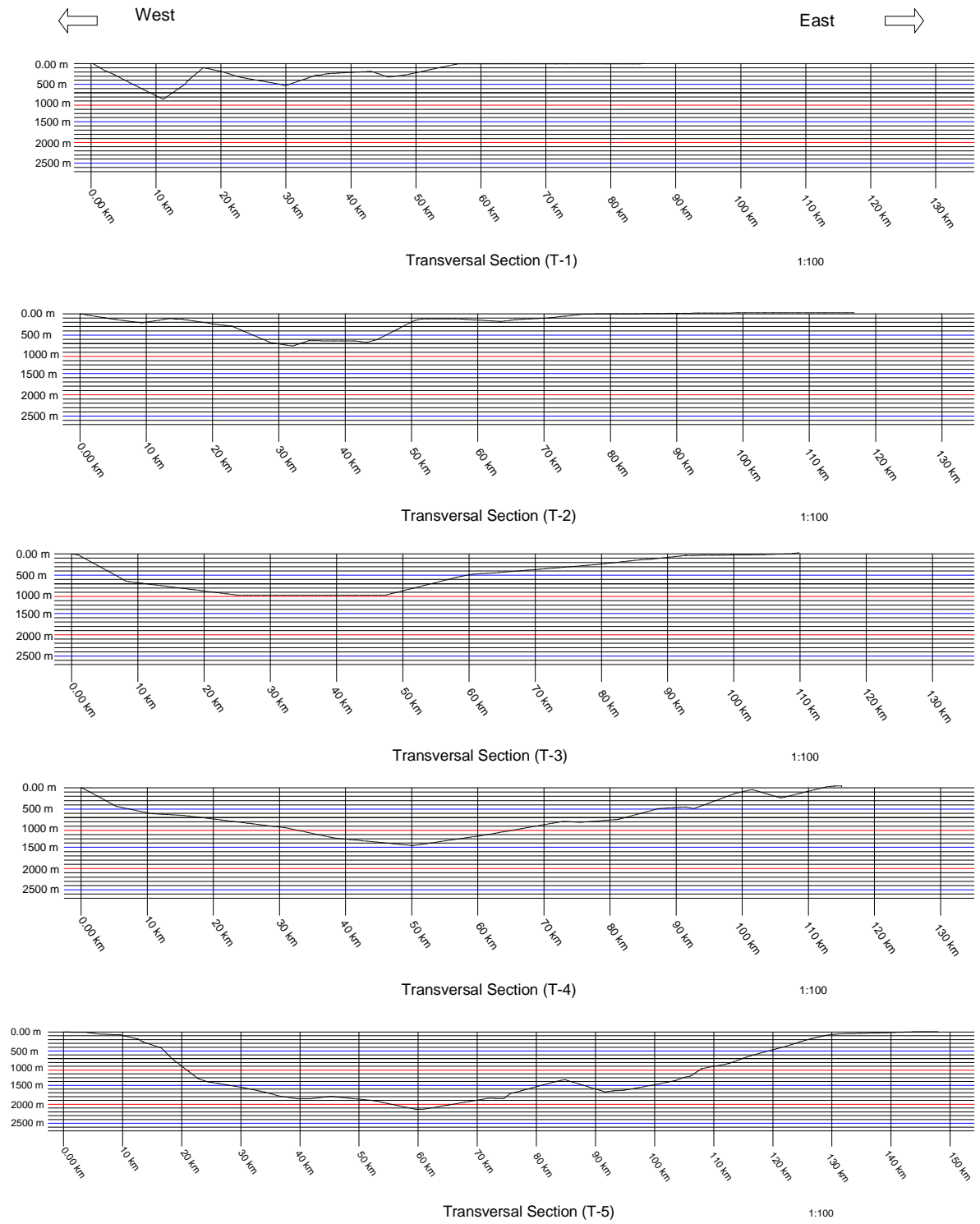

Figure 4.5 Transversal sections in the Gulf of California

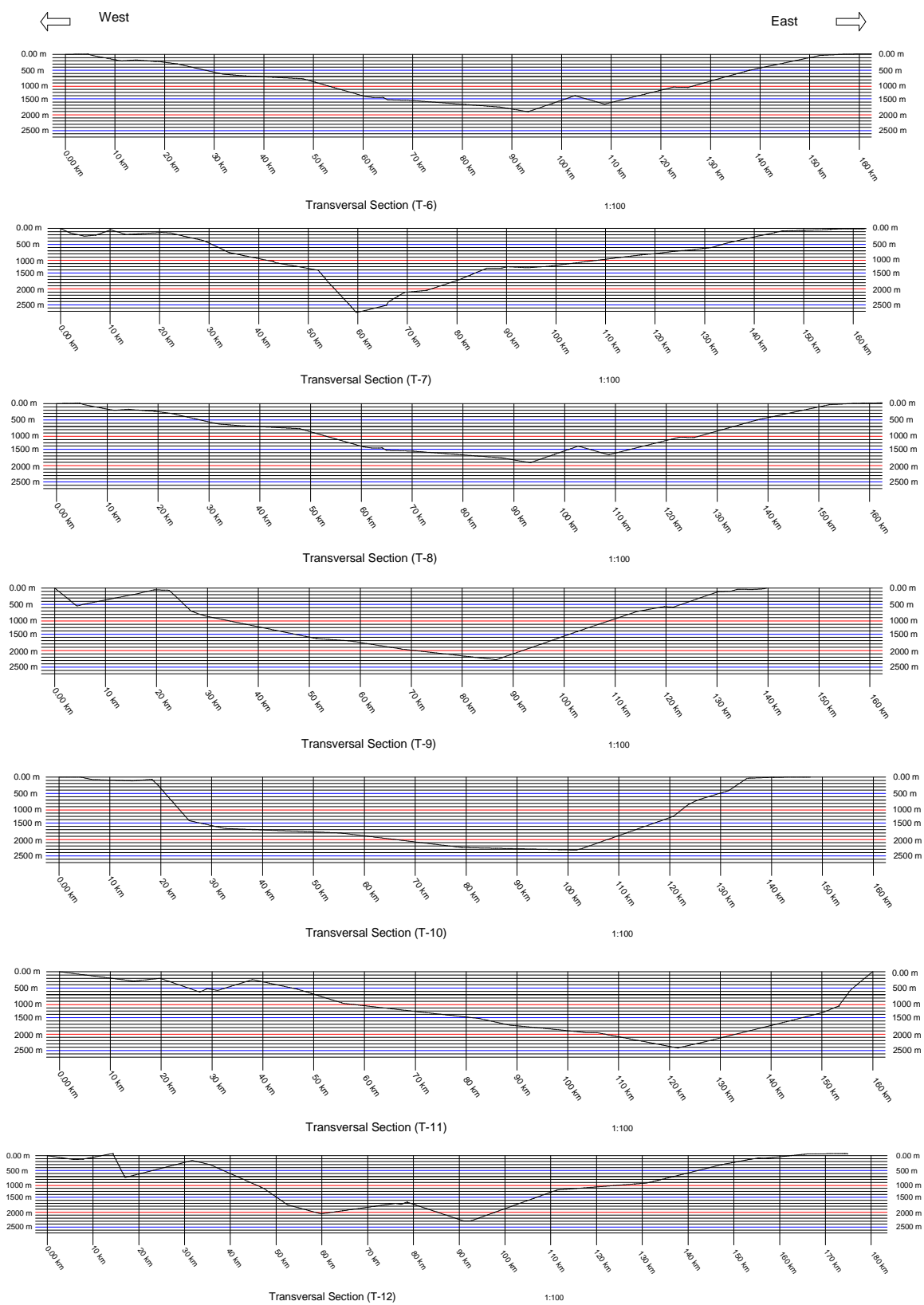

Figure 4.5 Transversal sections in the Gulf of California (continuation)

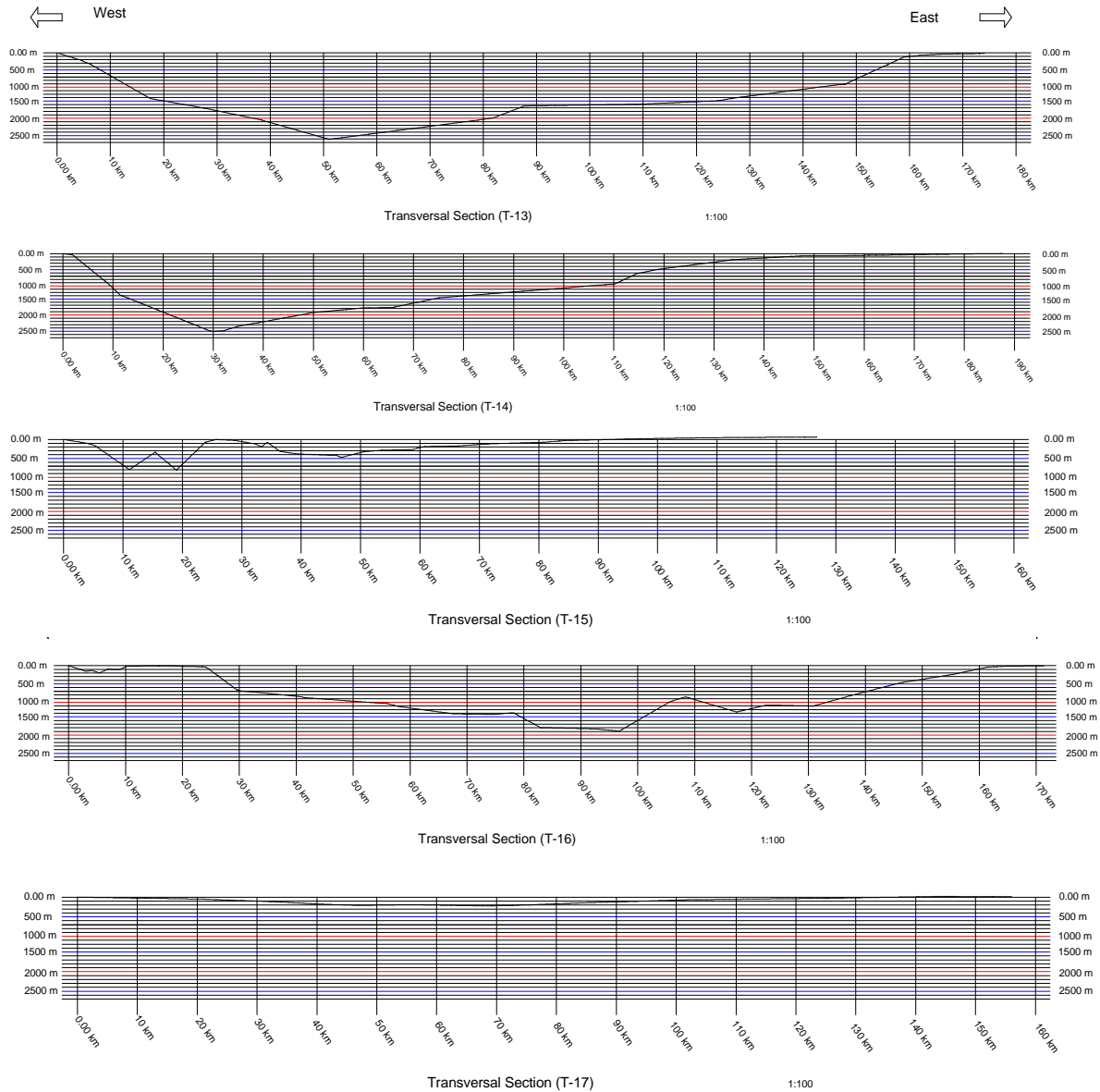

Figure 4.5 Transversal sections in the Gulf of California (continuation)

Starting on the criteria that the southern part of the gulf provides more benefits for the SFT location, the searching of the suitable transversal section has followed the process from the middle gulf until the mouth of it. These sections are numerically ordered; their location can be consulted in Figure 4.4.

It can be appreciated that the central section's T-1, T-2 and T-15 which are located near of the island complex at the middle gulf, have an adequate depth and length. In some parts of these sections the values overpass the depth criteria of 400 m.

Another group conformed for the sections: T-3 to T-10, and T-16 was studied. These sections cover the gulf from approximately 100 km under the island complex until almost 70 km above La Paz bay (Figure 4.4). The sections increase notoriously the depth of the crossing. From this group, the northern sections reach depths



until 1000m in their central part, which unfeasibly with the criteria previously established. In addition from section T-5 to T-10, they were found depths of until 2000 m, what is more critical for the location.

Following the ideal part of the location, a third group was established. From La Paz Bay, until the mouth of the Gulf, they were drawing four additional transversal sections. In sections T-11 and T-12 the values are quite similar from the second group. The sections reach maximum depths of around 2500m at their central and eastern. While in the sections T-13 and T-14 the location of the maximum depths are at the western part of these.

Since there are limited options for locating the SFT, one last transversal section was drawn. According to the longitudinal sections of the gulf (Figure 4.3), it was clear that in the northern part of the gulf the depths are less. Thus, it represents an option for the SFT location. However, some of these areas are restricted due are Natural Protected Areas, so it is an issue that must be taking in account. In chapter 3 was study the Natural Protected Areas in the Gulf of California and avoiding these reserves was taken as part of the criteria for the SFT location. Thereby it was study another section in the northern gulf named T-17. In Figure 4.5 can be appreciated that T-17 not overpass the 400 m depth criterion. Instead the maximum depth is around 200 m, what is at this stage a potential location for the SFT.

In general, once that the sections have been evaluated, it was notorious that in the southern part of the gulf the depths are larger than in the north, reaching depths until 2500 m. Moreover, in the centre the values of profundity are more acceptable with measures between 400 and 600 m in the middle of the sections. However, in the middle of the gulf are located the island complex which form parts of the Natural Reserved Area what it limits the location of the SFT.

Thereby, it was decided looking for a transversal section in the central part of the gulf. So a second round of transversal sections was studied. In this set the main concern of the criteria, it was to avoid the Natural Protected Areas, due to the island complex is really close to the possible SFT locations. Thus, the stroke of the transversal sections had to be made to avoid crossing throughout a natural reserve. The location of the transversal sections at the delimited region is shown in the Figure 4.6.

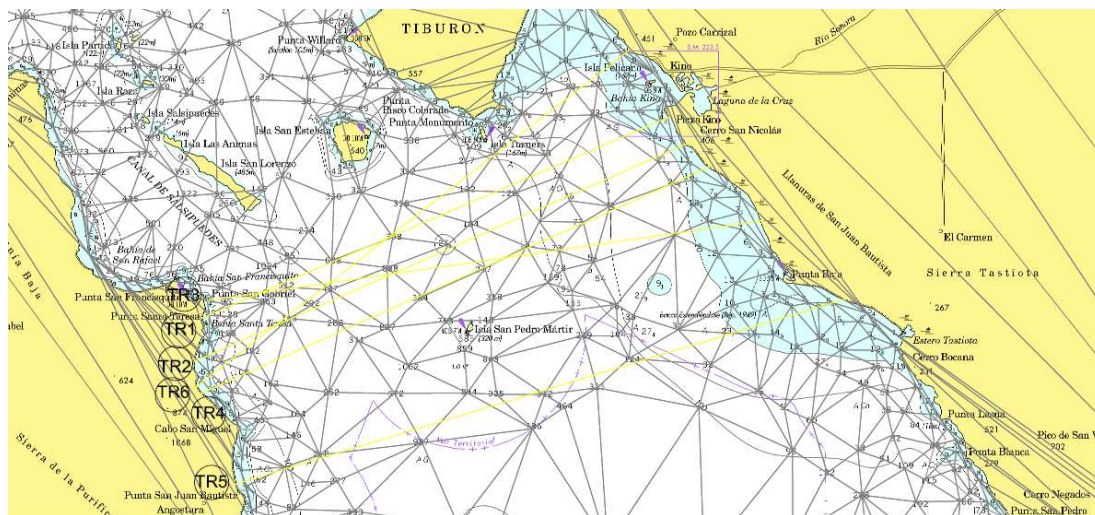

Figure 4.6 Location of the transversal section delimited at the central gulf

As it was expected, the transversal sections studied in the limited region at the middle gulf, are approximate to the required values. They can be compared to the sections L-1, L-2 and L-15 where the 400m-limit overpass just in some parts. The figure 4.7 shows the transversal sections in the delimited area at the middle gulf.

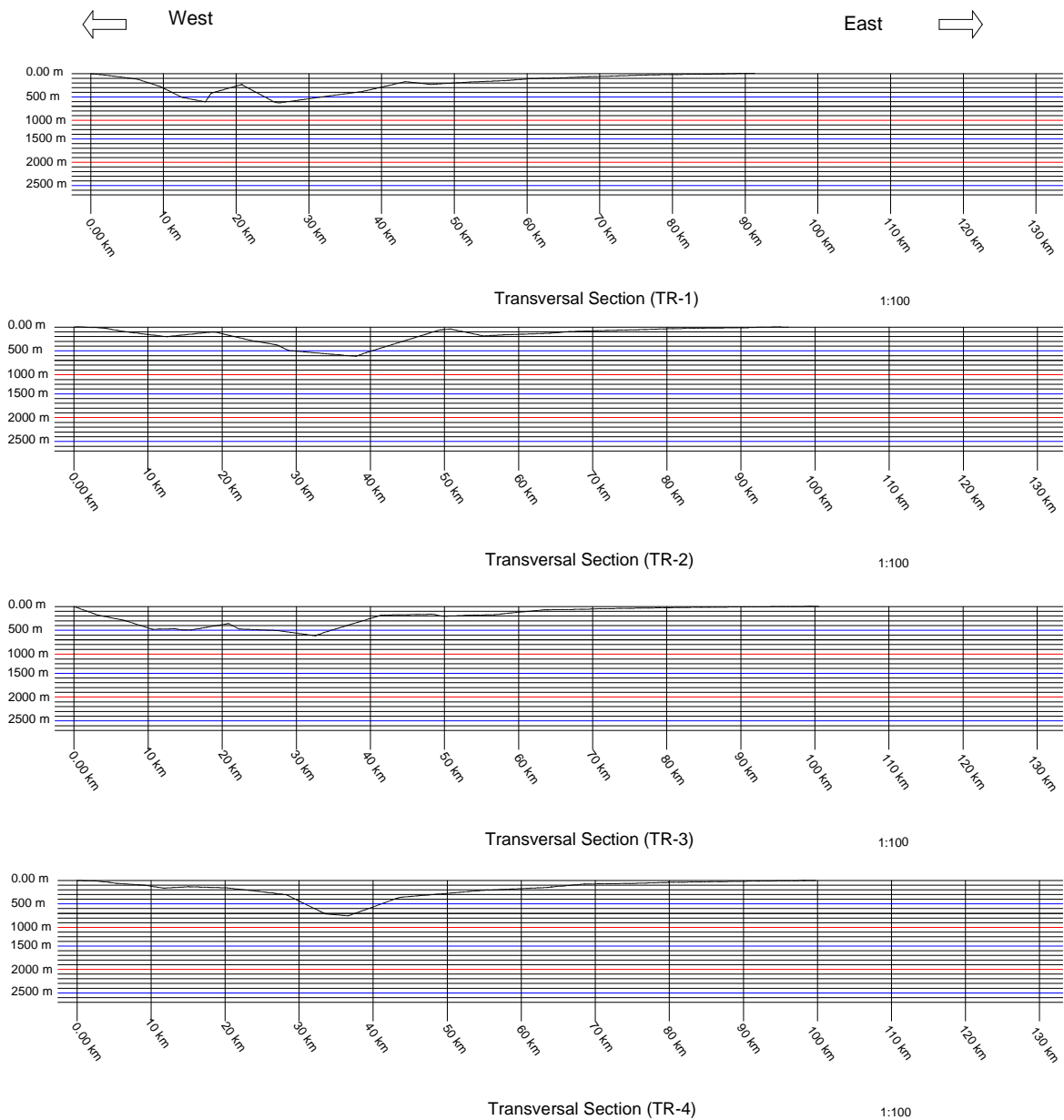

Figure 4.7 Transversal sections at the delimited region



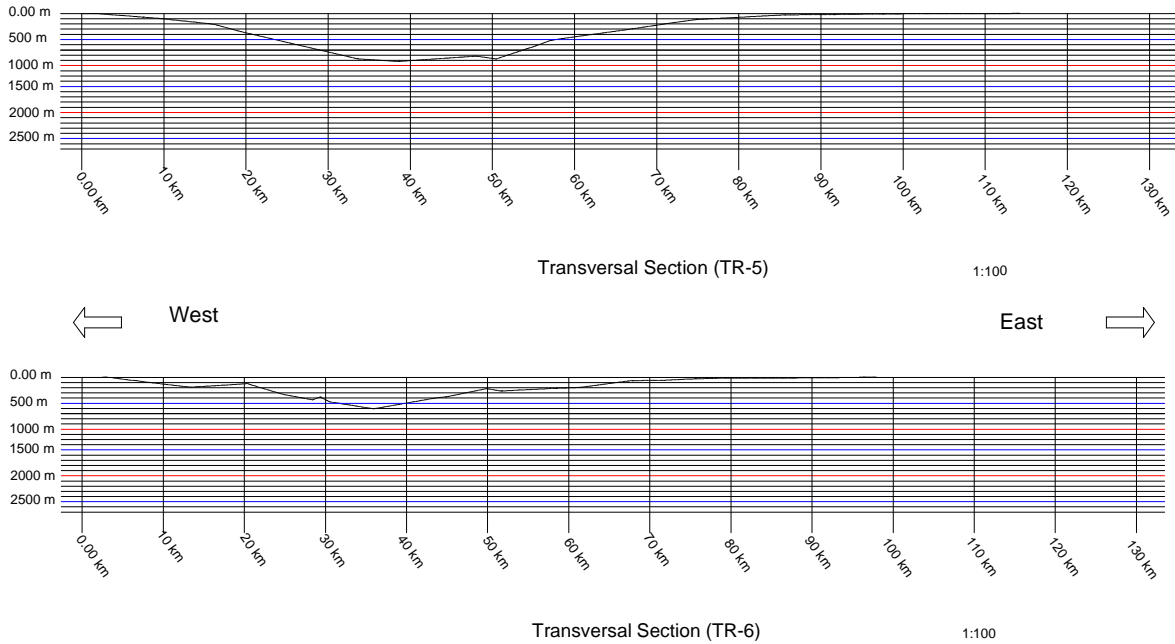

Figure 4.7 Transversal sections at the delimited region (continuation)

From Figure 4.7 can be appreciated that all sections from TR-1 to TR-6 overpass the 400-m depth in at least one segment of the 10 km. Furthermore, for section TR-5 the depth reaches the 1000 m in the centre of the seabed profile. Thus, another section in the northern part of the gulf was studied, named TR-7. The Figure 4.8 shows the seabed profile of TR-7. The location of this transversal section can be found in Figure 4.9.

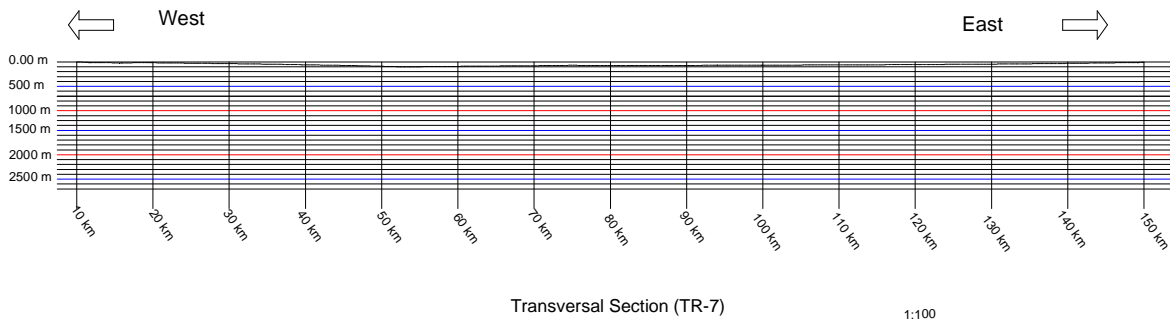

Figure 4.8 Transversal section in the northern Gulf

The transversal section TR-7 meets the depth criterion. The maximum depth at the section is minor than 100 m at its centre. However, the northern part of the gulf is less beneficial than the south. Therefore, some additional searching was realized near of the area for finally find a better section than the TR-7.

Hence another section was found. The latest section and also the definitive is named TD-1. It has a shorter length than TR-7 as well as is located more to the south which is another point of the criteria. The section has no more than 220 m depth an also it is outside of any Natural Protected Area. In the figure 4.9 it is shown the location of the definitive section TD-1 as well as the section TR-7.

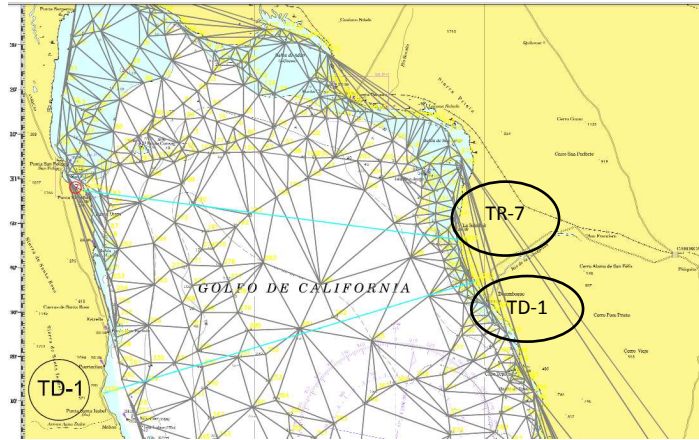

Figure 4.9 Location latest transversal section analyzed

In Figure 4.10 can be appreciated the seabed profile of the section TD-1.

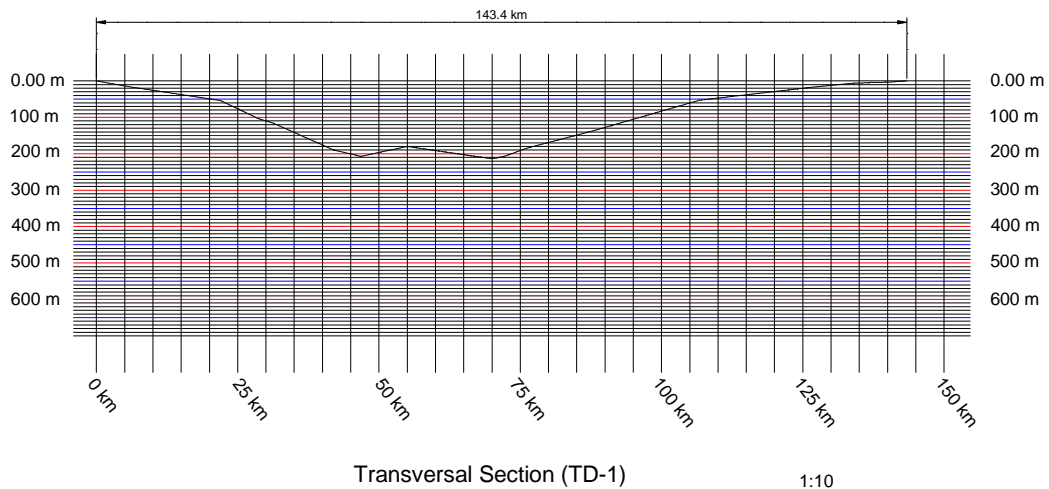

Figure 4.10 Seabed profile of the definitive section (TD-1)

#### 4.1.3. Evaluation of natural conditions at the location

Once the section of the crossing has been chosen, the evaluation of its natural conditions is carried on. The natural conditions have been evaluated according the data collected to forming the chapter 3 of this work. The information of natural conditions has been taken from different institutions in Mexico as well as other international partnership institutions with the Mexican government. The issues that were studied are listed here below.

- Bathymetry
- Type of ground
- Seismicity
- Water Temperature
- Winds
- Currents

- Tides
- Waves
- Meteorological Phenomena
- Shipping in the region
- Natural Protected Areas

Moreover, the data collected it considers the normal conditions of the environment in the gulf as well as the extreme conditions. Furthermore, it was found maximum historical values for some of the more relevant features in order to know the sea state. This information is helpful for comparing the natural conditions of others locations where Submerged Floating Tunnels have been proposed. In addition, it was analyzed these values along the whole section TD-1 divided by each 25 km considering that no significant variations were found.

All the details for this data can be consulted in the chapter 3 of this work. It is important to note that the information in the chapter 3 is general and contains the information for the whole Gulf of California. Thus, what it concerns for this section is the sea state for the location TD-1.

#### 4.1.3.1. Bathymetry

In Figure 4.10 can be appreciated that the depth of the seabed profile relative to mean sea level has a maximum value of 214 m. Therefore, this depth meets the criteria established in Section 4.1.1 of not exceeding a depth of 400 m in order to have an adequate lateral stiffness. Figure 4.10 shows a definite transverse profile TD-1 in a larger vertical scale, for greater appreciation of the deep changes.

#### 4.1.3.2. Type of ground

In the northern Gulf of California as is studied in Section 3.3.1, the soil is composed mainly of marine sediments at different depths. It is composed by marine sandstones, siltstones, shales and clays. In Figure 4.11 is shown the type of ground along the entire section TD-1 divided at depths of 0-100 and 100-200 meters below seafloor.

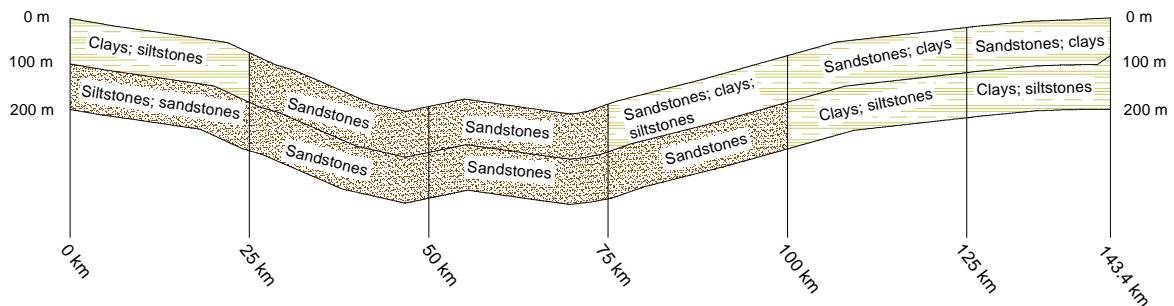

Figure 4.11 Type of ground along the section TD-1

#### 4.1.3.3. Seismicity

The seismic design spectra are based on the design manual for seism, issued by the Federal Commission of Electricity (CFE) in the year 1993. Table 4.1 presents the design spectra obtained, which are considered to be equal along the entire section TD-1 due to the similarity of the soil.

<b>Design Spectra</b>	<b>Value</b>
Peak Ground Aceleration	0.86 cm/s <sup>2</sup>
First Corner Period ( $T_a$ )	0.0 s
Second Corner Period ( $T_b$ )	1.2 s

*Figure 4.1 Design spectra for the section TD-1*

#### 4.1.3.4. Water Temperature

As it can see in the satellite images of the section 3.4 from this work, there is presented a great variation in water temperature throughout the year. In the particular part where is placed the definitive section TD-1, the minimum temperatures occur during the months of January, February and March, reaching temperatures up to 16 ° C. On the other hand, the maximum temperatures are presented during the months of August and September, appearing temperatures up to 32 ° C. The variations along the section TD-1 are negligible, thus the values of water temperature are considered equal in the whole section.

Table 4.2 shows the surface temperature for the region where is located the section (TD-1) during all months of the year.

<b>Month</b>	<b>Range of monthly average temperature (°C)</b>
January	<b>16-18</b>
February	<b>16-19</b>
March	18-20
April	20-22
May	22-24
June	25-26
July	27-30
August	30- <b>32</b>
September	30- <b>32</b>
October	27-29
November	23-26
December	20-22

*Table 4.2 Variation of the monthly average temperature on the surface at the section TD-1*

From the table 4.2 can be appreciated that the range of minimum and maximum temperatures of TD-1 fluctuates between 16 ° C and 32 ° C. This is important data for considering during the design step for the Submerged Floating Tunnel. The water variations affect the structure mainly in the longitudinal axis, thus the longitudinal displacements due these changes has to be considered at the land connections of structure as well as some intermediate joints.

#### 4.1.3.5. Wind

In section 3.5 of this work is studied the winds in the whole Gulf of California. It is notorious its variation throughout the seasonal periods. In the northern gulf, the maximum values are presented during the winter with southeast direction. In this period the maximum values reach the 4.5 m/s. Moreover, during the summer the winds run in northwest direction with velocities between 2.3 and 3.5 m/s. The wind magnitudes of the particular section TD-1 are shown in Table 4.3.

Month	Velocity between 0-40km (m/s)	Velocity between 40km -80km (m/s)	Velocity between 80km-120km (m/s)	Velocity between 120km-143.4km (m/s)
January	2.5-3	2.5-3	2.5-3	2.5-3
February	1.5-2	2-2.5	2-2.5	<b>4.5-5</b>
March	0.5-1	1.5-2	1-0-1.5	1-0-1.5
April	0.0-0.5	2.0-2.5	1.5-2.0	2.5-3
May	1.5-2	2-2.5	1.5-2	1.5-2
June	2-2.5	2-2.5	2.5-3	2-2.5
July	3.5-4	3-3.5	<b>3.5-4</b>	3-3.5
August	3.5-4	2.5-3	3-3.5	2.5-3
September	1-1.5	2-2.5	2-2.5	1.5-2
October	<b>6.5-7</b>	1.5-2	1-1.5	2-2.5
November	4-4.5	3-3.5	3-3.5	0.5-1
December	5.5-6	<b>4-4.5</b>	<b>3.5-4</b>	3.5-4

Table 4.3 Wind velocity average at the section TD-1 from 1999-2006

#### 4.1.3.6. Currents

Similar to wind and temperature, the currents in the Gulf of California present notable variations throughout this. According to section 3.6, in the northern gulf the maximum values are presented during the summer, reaching values of around 32 cm/s. Moreover, the values during the winter are less than a half with values between 12 cm/s and 16 cm/s. The minimum values are presented during October, reaching a velocity of 6 cm/s in from the center to the west coast of section TD-1. In Figure 4.12 are schemed the current magnitudes throughout the section TD-1.

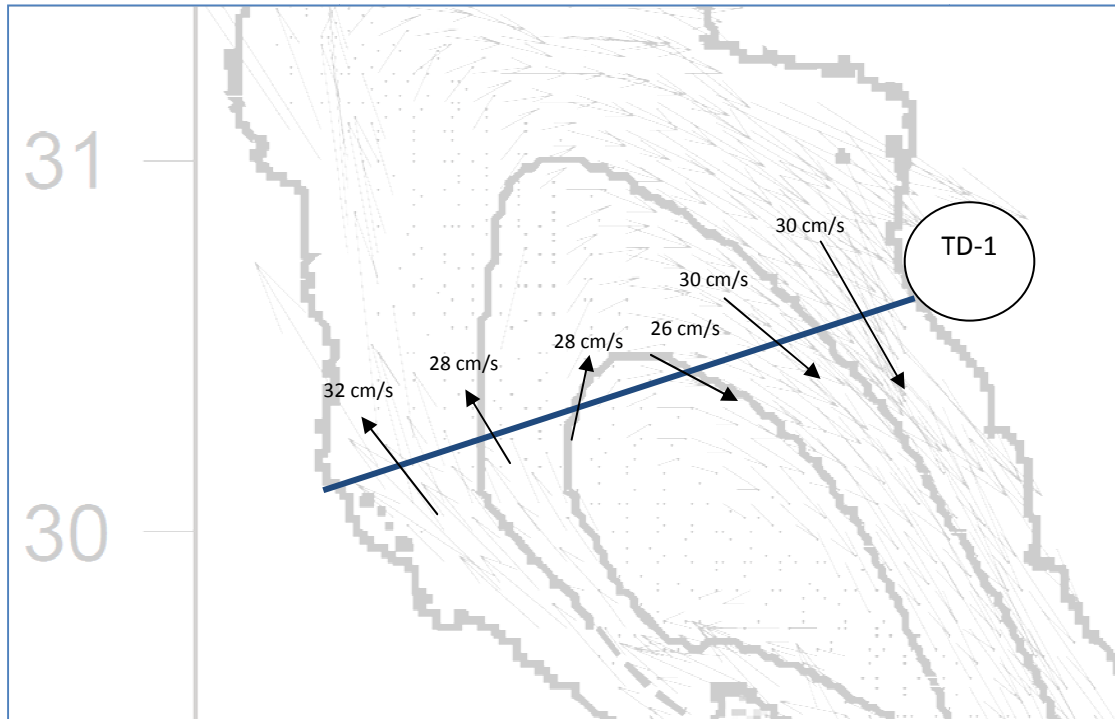

Figure 4.12 Resulting of the current velocity in the section TD-1 on the surface and 25m depth

#### 4.1.3.7. Tides

In general, tides in the Gulf of California are semi-diurnal type, it means maximum levels and two minimum in one single day. As is studied in Section 3.7, the amplitudes in the sea level at the northern Gulf have their greatest magnitudes. The particular data near to the section TD-1 is the most important for the evaluation purpose. The oceanographic stations of interesting data are presented in Table 4.4.

Oceanographic Station	Location	Mean High Higher Water (m)	Mean Lower Low Water (m)	Maximum Mean High Higher Water (m)	Minimum Mean Lower Low Water (m)	Amplitude of maximum tide (m)
San Felipe, B.C.	31°01' N 114°49' O	2.096	-2.019	3.827	-3.122	6.949
Bahia de Los Angeles, B.C.S.	28°57'N 113°33'O	0.990	-1.018	1.847	-1.932	3.779
Puerto Peñasco, Son.	31°18'N 113°33'O	2.148	-2.139	3.829	-3.249	7.078
Guaymas, Son.	27°55.3'N 110°53'O	0.357	-0.474	0.854	-1.188	2.042

*Table 4.4 Oceanographic stations proximate to the section TD-1*

It has to be noted that Section TD-1 is located between latitudes 30°10'N at its west on the peninsula of Baja California while at 30°40'N in the territorial coast, so there is no measuring station near of its ends. For purposes of the preliminary design of SFT, have taken the values of the stations which have the greater tidal amplitudes, following the criteria that are most important values when is dealing with floating structures. A fact is that for SFT is vital to maintain the minimum clearance above its top for allowing the shipping navigation in the area. From Table 4.4, the greater amplitudes are 6.95 m at the part of the peninsula of Baja California while the maximum value at the east coast it about 7.08 m. Thereby, the tidal amplitude of design for the SFT is will be consider of 7.0 meters.

Note that the maximum historical tide levels have been presented under extreme conditions such as meteorological phenomena, tsunamis and other extraordinary phenomena in the area until the year 2013.

#### 4.1.3.8. Waves

According the section 3.8 of this work, the wave height at the northern part of the gulf varies from 1 to 8 m in the different seasons of the year for a return period of 100 years.

In the location of section TD-1, during the winter and spring the wave heights are between 1 and 3 meters, resulting the first season with minor values than the first. Furthermore, during the summer and fall, are presented the maximum values of wave heights. These magnitudes reach the 6 m at the west end of the TD-1 section and 8 m at the opposite end.

#### 4.1.3.9. Meteorological Phenomena

It is really important to consider the extreme conditions to which the SFT will be subject. The extraordinary conditions must be considered during the preliminary design in order to provide an adequate structure which resists the diverse strengths. As it is studied in section 3.9 the greatest values during extreme conditions are presented in the northern gulf. The wave height reaches magnitudes of 12 meters with periods of 12 seconds. On the other hand, the wind velocity is lower in the north part of the Gulf of California, where has been

observed measures between 110 km/hr and 150 km/hr, it being greater the values at the east coast. In Table 4.5, are summarized the historical maximum values from 1947 to 2007 under meteorological events that have arisen.

Feature	Magnitude
Maximum Wave Height	8.5 m
Maximum Wave Period	12 s
Wind velocity under storm conditions for a 100-year return period	150 km/hr

Table 4.5 Extreme environmental conditions in the section TD-1

#### 4.1.3.10. Shipping in the region

As discussed in section 3.10 the marine traffic in the area is highly dependent on the Gulf region where is located. The ports proximate to the section TD-1 are presented in Table 4.6.

Port Name	Mexican State	Draft (m)
Puerto Libertad	Sonora	13.71
Puerto Peñasco	Sonora	4.00
Golfo de Santa Clara	Sonora	7.00

Table 4.6 Official draft of the ports proximate to the section TD-1

From Table 4.6, can be appreciated the great difference between the drafts of the ports in the region. Thus, the maximum value of these measures would be the governing depth in order to provide the minimum clearance from the top of the Submerged Floating Tunnel to the water surface. Thereby, for the preliminary design of the SFT the required draft for shipping navigation would be of 14 meters.

#### 4.1.3.11. Natural Protected Areas

Avoid Natural Protected Areas is one of the criterion established in section 4.1.1. Thus, since it has been searched for the suitable location, this criterion has been taking in account. The main purpose of this point is not disturbing the natural environment of the region, both in the mainland as well as marine life. Therefore from Figure 4.13 can be appreciated that the section TD-1 not touches a Natural Protected Area.



Figure 4.13 Location of the SFT in the Gulf of California with respect to Natural Protected Areas in the region



#### 4.1.4. Comparison of the definitive location with others SFT locations proposed around the world

After comparing the natural conditions at the location TD-1 in the Gulf of California, it must be summarized the different issues study in section 4.1.3. Thus some other considerations might realize for having comparative data of the different proposals. The extra considerations are the followings:

- The location of the SFT need a minimum clearance of 14 m. Therefore, the tide in the region has amplitude of 7 m, thus the location of the SFT's top would be placed at 25 m under the M.S.L. Having extra 4 m of tolerance.
- The maximum current velocities are in the water surface due the direct wind impact. Moreover, the current velocity at the seabed is considered negligible or zero. Therefore, the currents at 25-m depth are obtained linear decreasing.
- The surface currents during extreme conditions are considered proportional to the normal conditions, according the wind velocity during both situations. Consequently, the currents at 25-m depth during extreme conditions have the same consideration as above.
- Due it was not available information of wave period during normal conditions, this data is proportional than the wave period during extreme conditions for the winds reported in both situations.
- The wave length for both conditions is obtained as (Martire, 2007):  $\lambda_w = 1.56 T_w^2$  ;  $\lambda_w$  (meters) ;  $T_w^2$  (seconds).

In the Table 4.7 are summarized the data of the environmental conditions in section TD-1. Due the length of almost 150 km, these values are divided in groups of 25 km, considering that is a sufficient length with no much variation in their conditions. The fact is that greater values would govern the design of the structure.

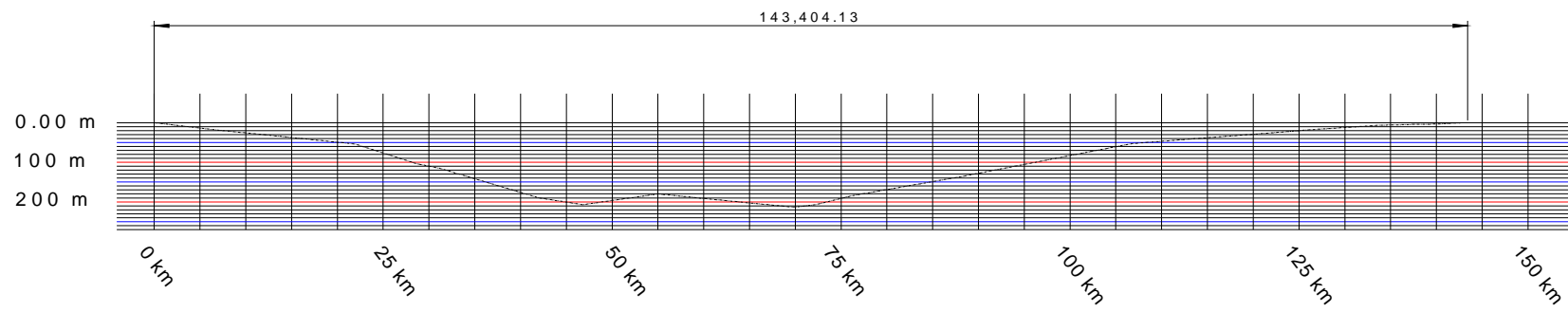

Environmental Conditions	NC 0-25	EC 0-25	NC 25-50	EC 25-50	NC 50-75	EC 50-75	NC 75-100	EC 75-100	NC 100-125	EC 100-125	NC 125-143.4	EC 125-143.4
Type of Ground at 0-100 m under seabed	Clays and Siltstones		Sandstones		Sandstones		Sandstones, Clays and Siltstones		Sandstones and Clays		Sandstones and Clays	
Type of Ground at 100-200 m under seabed	Siltstones and Sandstones		Sandstones		Sandstones		Sandstones		Clays and Siltstones		Clays and Siltstones	
Peak Ground Acceleration	0.86 cm/s <sup>2</sup>		0.86 cm/s <sup>2</sup>		0.86 cm/s <sup>2</sup>		0.86 cm/s <sup>2</sup>		0.86 cm/s <sup>2</sup>		0.86 cm/s <sup>2</sup>	
Surface Temperature °C	16°C-32°C		16°C-32°C		16°C-32°C		16°C-32°C		16°C-32°C		16°C-32°C	
Temperature at 150 m depth °C	-		5°C - 16°C		5°C - 16°C		5°C - 16°C		-		-	
Winds	7 m/s	110 km/hr	6.5 m/s	120 km/hr	4.5 m/s	130 km/hr	4 m/s	130 km/hr	4 m/s	140 km/hr	5 m/s	150 km/hr
Surface Currents	32 cm/s	1.4 m/s	28 cm/s	1.4 m/s	28 cm/s	2.2 m/s	26 cm/s	2.3 m/s	30 cm/s	2.9 m/s	30 cm/s	2.5 m/s
Currents at 25 m depth	21.3 cm/s	0.9 m/s	24.6 cm/s	1.23 m/s	24.7 cm/s	1.9 m/s	22.2 cm/s	2 m/s	20.9 cm/s	2 m/s	0.01 cm/s	0.01 cm/s
Mean High Higher Water	2.10 m	3.83 m	2.10 m	3.83 m	2.10 m	3.83 m	2.15 m	3.14 m	2.15 m	3.14 m	2.15 m	3.14 m
Mean Lower Low Water	2.02 m	3.12 m	2.02 m	3.12 m	2.02 m	3.12 m	2.14 m	3.15 m	2.14 m	3.15 m	2.14 m	3.15 m
Tide amplitude	4.12 m	6.95 m	4.12 m	6.95 m	4.12 m	6.95 m	4.29 m	6.29 m	4.29 m	6.29 m	4.29 m	6.29 m
Wave height (Hw)	6 m	8 m	6.5 m	8.5 m	6.5 m	8.5 m	6.5 m	9 m	7 m	9 m	8 m	9.5 m
Wave period (Tw)	3 s	8 s	3 s	12 s	4 s	12 s	4.5 s	12 s	5 s	10 s	5 s	8 s
Wave Length (λw)	14 m	99.80 m	14 m	224.60 m	25 m	224.60 m	31.60 m	224.60 m	39 m	156 m	39 m	99.80 m
Minimum clearance above the SFT	25 m		25 m		25 m		25 m		25 m		25 m	

Simbology:

NC= Normal Condition

EC= Extreme Condition

Table 4.7 Summary of the environmental conditions at the section TD-1at the surface and at 25 m depth

Once is collected the data related with the environmental conditions in the section TD-1, the different features can be compared with others location where a SFT has been proposed. Martire (2007) analyzed three different environmental conditions in his work. The waves and current characteristics of the Qiandao Lake, Jintang Strait and Messina Strait, which represent mild, intermediate and severe conditions, have been studied. Moreover, the seabed depth and water clearance values have been correlated to each of the previous environmental condition. The wave and current parameters are the most important issues which define the severity of the hydrodynamic actions. The Table 4.8 summarized the three different conditions as well as the characteristics of the north part of the Gulf of California where the section TD-1 is located.

Location site	Condition	depth	clearance	Wave Height	Wave Length	Period Wave	Current Velocity
Qiandao Lake	Mild	30 m	2.0 m	1.0 m	8.25 m	2.3 s	0.1 m/s
Jintang Strait	Intermediate	100 m	25 m	5.8 m	76.5 m	7.0 s	4.1 m/s
Messina Strait	Severe	200 m	30 m	13.5 m	200 m	11.5 s	3.45 m/s
Gulf of California (TD-1)	Intermediate-severe	213 m	25 m	9.5 m	99.8 m	8.0 s	2.9 m/s

Table 4.8 Comparison between locations for SFT proposals

From Table 4.8 it can see that the characteristics of the natural conditions of TD-1 are among the intermediate (Jintang Strait) and the most severe condition (Messina Strait).The wave conditions of TD-1 are similar with the Chinese crossing, presenting just a little variation. Moreover, the current velocity in the Mexican crossing even under extreme conditions is minor than the intermediate and severe condition crossings. Hence, the natural conditions in the Gulf of California at the TD-1 location are acceptable for placement of the Submerged Floating Tunnel.

Therefore, the hydrodynamic study carried out by Martire (2007) is acceptable for this work. In the study, Martire (2007) evaluate the behavior of different typologies and configurations of SFT. The load conditions were based on the first three environmental conditions shown in the Table 4.8. The analysis revealed that the configuration shown in Figure 4.14 has the best behavior against hydrodynamic actions.

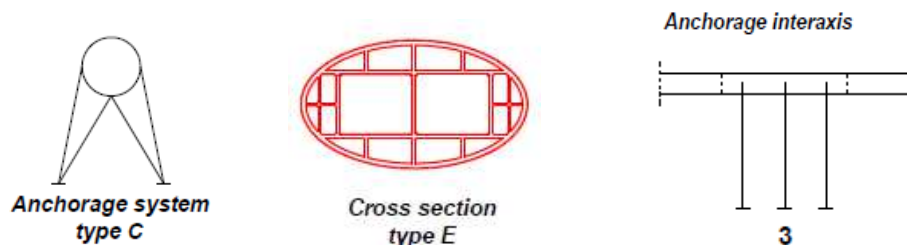

Figure 4.14 Ideal anchorage configurations for SFT (Martire, 2007)

This anchorage configuration improves the lateral and vertical displacements as the length of the SFT increase. In the results of the study of Martire (2007), for a SFT of 3000m length the lateral displacement is about 7 cm, while the vertical displacement is negligible. Thus, the unit displacement (meter) is about  $2.33 e^{-5}$ . Thereby, for the 143.4-km length SFT of the Gulf of California, the approximately lateral displacement would be around 3.35 m which is negligible considering the length of the crossing.

## 4.2 Geometry of the cross-section

Dimensioning the cross-section for the SFT has been one of the most important steps of the work. This task has to involved many considerations like no other tunnel project has been done. It is obviously that this project would be so far compare to the actual tunnel projects placing around the world. So, this issue, was the more complex part of the SFT design where had to be consider and compare many solutions for tunnels around the world (Study that take place in the chapter 2 of this work project).

Concerning of the length of the SFT which is about 150 km special actions were took. These actions are widely described in the following sections of this work. The design of the cross section followed these criteria:

- The cross section shape would be rectangular due the ease construction process.
- Additional devices might be considered in order to provide better hydrodynamic behavior.
- The internal geometry shall be larger enough to house the facilities required.
- The cross-section must guarantee the safety of drivers.
- An especial cross-section must be design to be placed every 6 km, in order avoid the monotony of the journey. These greater sections must house the mechanical and electrical facilities required for the tunnel operation.
- Since along the tunnel are considerate two stops for evacuation through towers (Figure 4.1), the especial cross-section shall provide the space required for these structures.
- The connection between the regular or standard cross-section and the especial cross-section must be realized through a transition cross-section.

### 4.2.1. Standard Cross-Section

The design of the standard cross section has been developed after many considerations and improvement to the initial designs. According the established criteria, a rectangular cross-section was chosen for ease from the construction point of view. So then it were established the SFT requirements such as destination of use, number of road lines, dimensions of the traffic allowed, safety, ventilation and so on, but still in a early design. The first standard cross-section design is showed in the figure 4.15.

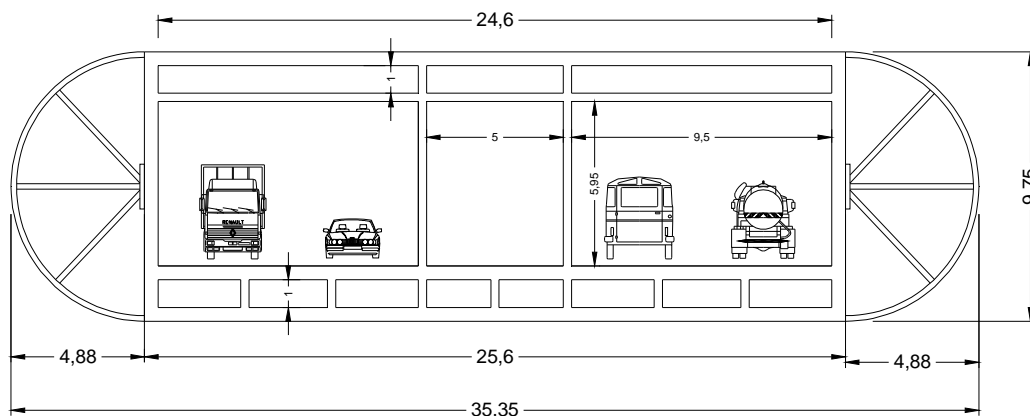

cross-section proposed CS-1

Figure 4.15 First standard Cross-Section Design (measures in meters)

As it can be appreciate in the Figure 4.15, the emergency lane is placed at the centre of the section. The road lane dimensions are the required for the circulation in tunnels which are typical used for immersed tunnels. Other remarkable characteristic, are the circular complements attached to each side of the module, this with the purpose for decreasing the hydrodynamic actions.

Once is analyzed this section, it was modified the lateral devices, enlarger them to try to figure a couple of halls, which would be result for a better hydrodynamic behavior for the structure. In addition, an internal decrease of the geometry was made in order to do not have a really huge section. The figure 4.16 shows the second design.

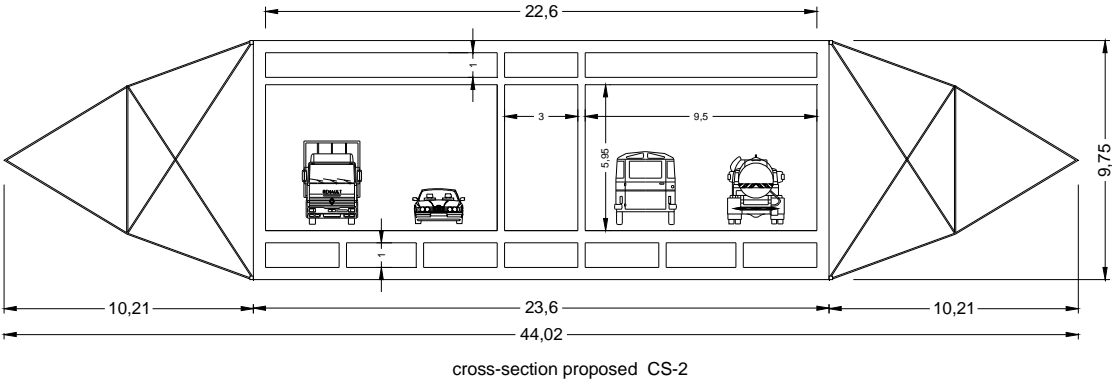

Figure 4.16 Second standard cross-section design (measures in meters)

In like manner was analyzed the section above. In addition the codes and requirements for tunnels were reviewed. Furthermore, were studied the mains projects of tunnels around the world, including subsea tunnels, road tunnels and immersed tunnels (section 2.3). The major priority was given it for the longest and modern tunnels, used for motorways and immersed tunnels, considering that are the most similar structure to an SFT.

It was really notorious the improvement after applied tunnel regulations. So a third design was carried out (Figure 4.17). The needed of specials elements located constantly along the tunnel. Thus, the design of one cross consisted in the regular cross section along the whole tunnel, other which was placed every 1000 m where emergency lay bys at each side were considered, and the third one which is located every 6000 m previously established in the design criteria.

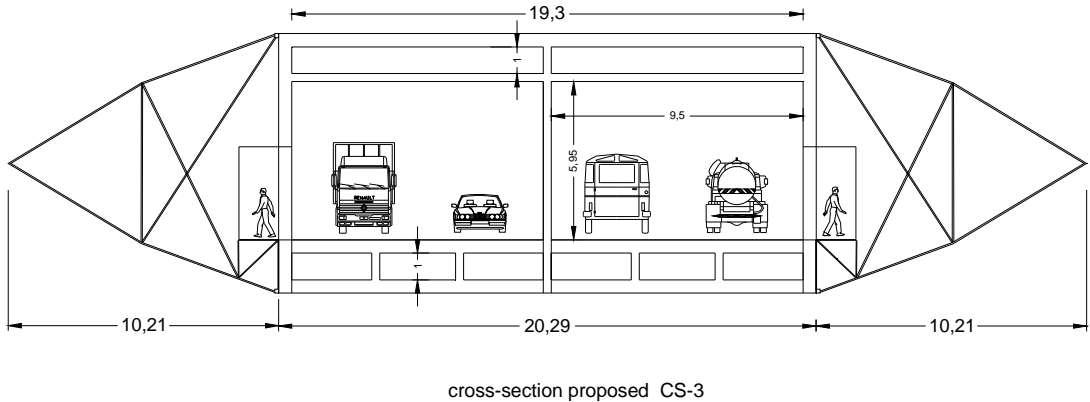

Figure 4.17 Third standard cross-section design (measures in meters)

As it can be appreciated in the Figure 4.17 the main modification with respect the previous designs, is the emergency configuration. This section changes the emergency passage from the centre to a single pedestrian lane to each side of the SFT. This drastic alteration can be done once are added the special modules along the tunnel which would provided more safety. The additional sections would allow to drivers stop every 1000 m at the emergency lay bys, moreover, the special modules placed every 6000 m, would allow to drivers stopping to rest or change the monotony of the large journey. For give more clearance a sample for the longitudinal distribution is presented in the Figure 4.18

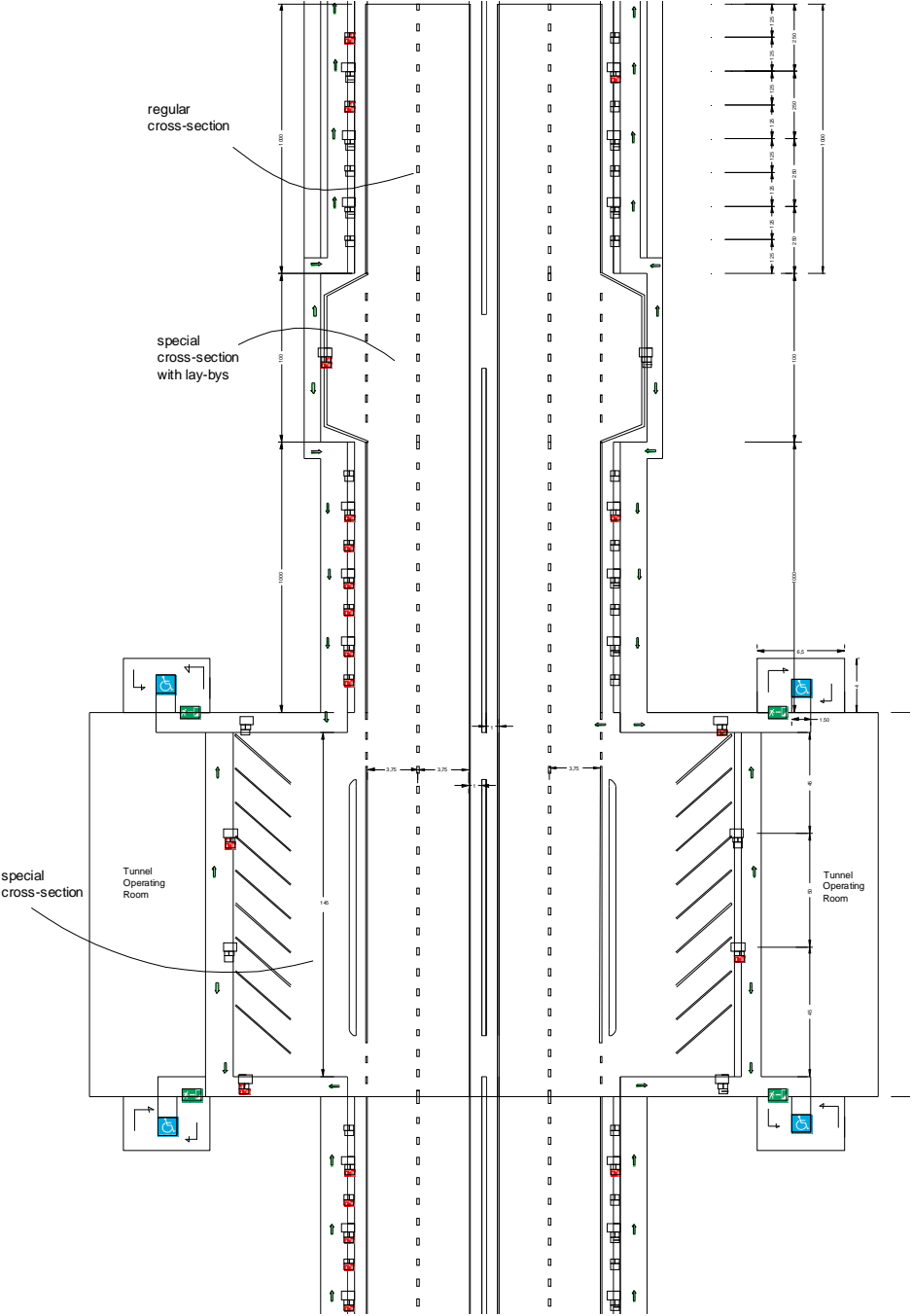
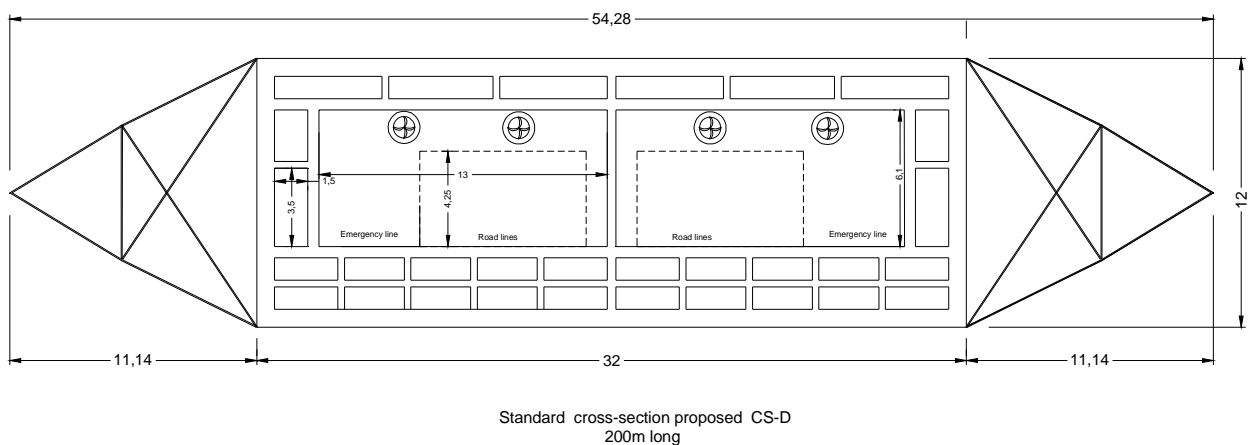

Figure 4.18 First longitudinal distribution design

After the third design was analyzed, were found some structural neglect mainly in the connections between the different elements. Some walls could not be joined each other and the stiffness of the structure could not be guaranteed with these differences. Moreover, the lateral emergency passage was placed outside of the main SFT structure, within the lateral devices. Thus, the emergency corridor would be on danger if a lateral collision is presented and also if infiltration problems occurred.

Thereby some modifications and additions were presented for having the final design for the standard cross section. In order to decrease the number of different cross section as well as the transition elements, it was decided to eliminate the element with lay bys, for adding an emergency lane in the normal cross section. The decision was based on the minimum requirements for tunnel safety in the European Union (2004/54/CE). This change besides will provide more safety during the journey in the tunnel, and also it will decrease the number of special joints between the elements. Moreover, it will allow having longer elements during the erection, and in consequence the number of joint will be reduced. Furthermore, if the elements were less, the submersion works would reduce so the cost as well would decrease. In addition, if there are fewer elements to submerge the period of the project will be shorter.

Additionally, there were incorporated some security gaps around the tunnel, with the purpose of having an special space where in case of collision from out or inside, an extra wall it would remain and it can be avoid a several damage to the SFT with catastrophically consequences. This main improvement can be appreciate in the Figure 4.19 and is considered the definitive standard cross-section for the SFT of the Gulf of California.



*Figure 4.19 Standard Cross-Section for the SFT of the Gulf of California (measures in meters)*

Moreover, the long of each module is established of 200 m to assure the anchorage system with a distribution of symmetric spans. Details of the anchorage system are studied at the section 4.3.3 of this work.

#### 4.2.2. Special Cross-Section

As it was established in the criteria of cross section geometry, it must be placed special modules every 6000 m. This special module has a larger cross section with enough space for parking area and some service for human necessities as toilets and first aid module. In addition, it is to be used for housing components of the tunnel operating system.



On the other hand, four special towers have been adapted for this module in two strategy location along the SFT. These towers has the function of evacuation exit as well as service area, where can be found a restaurant, shopping or simply viewer area just for break the monotony of driving in the long tunnel. Details of the structure are explained later on in the section 4.3.7.

In the same way of the standard element, a couple of designs were realized. The first design of the special module is shown in the Figure 4.20.

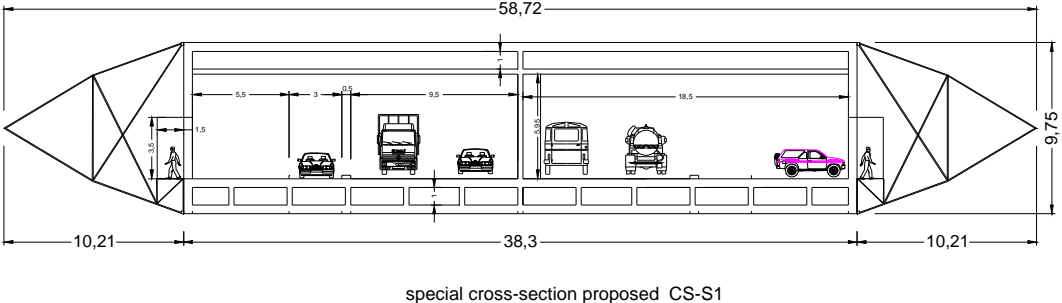

Figure 4.20 First special cross-section design (CS-S1) (measures in meters)

The module CS-S1 is schematized in the longitudinal distribution of the Figure 4.18. As it can be appreciated, the design consider the emergency exit for pedestrians outside of the main structure what it exposed this corridor to danger in case of lateral collision or water infiltration. Moreover, the space for housing the mechanical, electrical and ventilation system was not enough.

Thereby, a second design was carry on. It was adopted the idea of housing the operating system under the road lines. This with the purpose of provides more space for the mechanical and electrical system as well as a transverse passage in case of emergency. So then, it could be used as emergency exit and evacuation in case of the special modules with towers. In this design is considered the double-wall system for protection.

A notable change was the height of the module, once the tunnel operating room was under the road lines, for consequence the hydrodynamic lateral devices were enlarger gave as results a really huge structure. In addition the joint of the steel keels would represent another structural problem due the size differences. The second layout is shown in the Figure 4.21

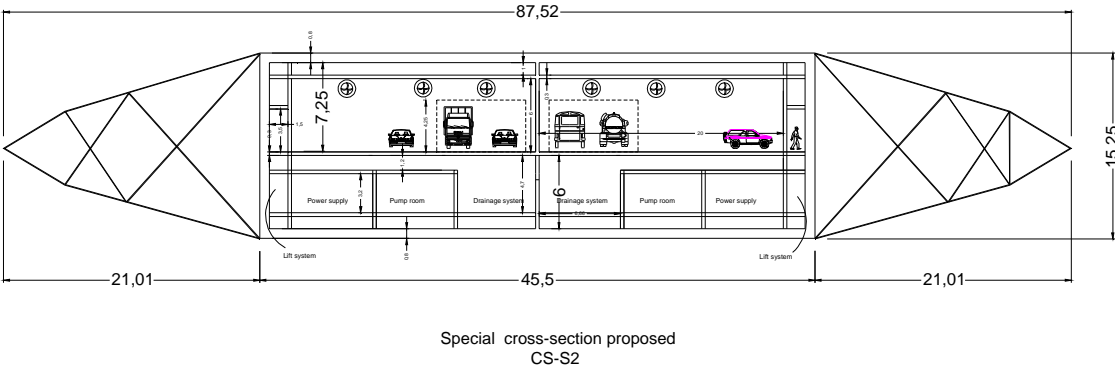

Figure 4.21 Second special cross-section design (CS-S2) (measures in meters)

The design CS-S2 involved the functional and safety requirements for the section goal. Unfortunately, the problem was in the structural point of view. Connecting this special cross-section with the standard cross-section with a lower height, it would present another stability and stiffness problem.

Thereby it was executed a third design. In this case the operating system room is placed at each side of the cross section. It is given the enough space for housing these systems:

- Sumps
- Pump rooms (for sumps and the fire suppression system and hydrants)
- Power supply
- Gaseous suppression
- Ventilation (purifying filters)
- Drainage system
- Other technical facilities.

On the other hand, it was adopted the double walled system done for the standard cross-section with the purpose of protecting the structure in case of an internal or external damage. It has been considered the enough space and geometry for parking area, allowing parking buses in a specific zone of the module. As well a pedestrian area has been added according to the codes from parking areas design from Mexico (Handbook of road geometrical design-SCT). A total of four first aid module has been placed along the special cross-section, two in each direction. As well a special gap has been destined for the evacuation towers. When the special module is placed without this evacuation route, the space is filled with ballast in order to have less residual buoyancy.

In the Figure 4.22 is shown the definitive special cross-section design adopted for the SFT of the Gulf of California.

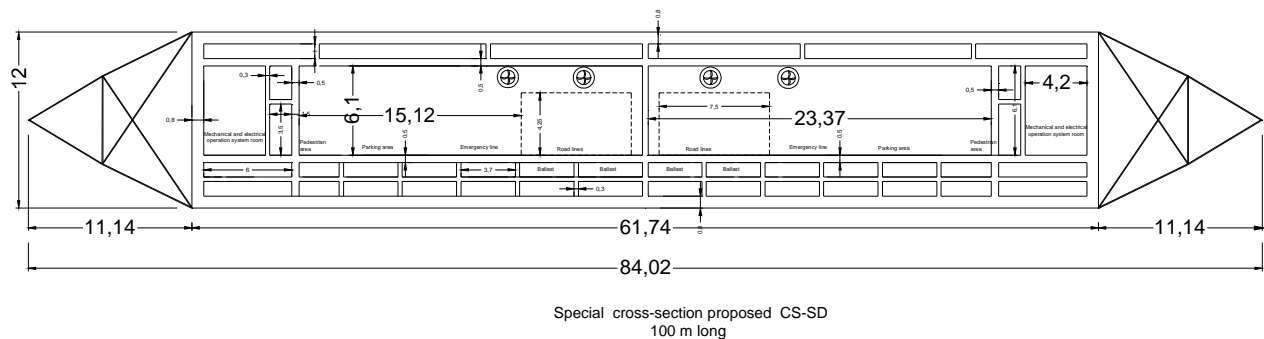

Figure 4.22 Special cross-section for SFT of the Gulf of California (measures in meters)

Considering the facilities necessary in the whole element even when the towers are not placed, a length of 100 m is defined. Within the hundred meters distance, is provided enough space for the operating system even when the towers are placed in the module. The solution helps to keep the same cross-section design as well as the transition design along the whole SFT, decreasing more special joints as well as variations in module geometry. Thus the production of the special modules could be standardized.

Details of distribution of the operating system room are in the longitudinal distribution layout that can be found in the section 4.3.7 of this work.

### 4.2.3. Transition cross-section

In order to assure the link between the different types of cross section (standard and special) was necessary to create a transition module with variable width. This module (CS-T) has in one extreme the geometry of the standard cross-section while in the other end the geometry of the special cross-section has been adopted. Furthermore, the height of the different elements is constant, it being easy to connect during the erection step as well as provide an adequate longitudinal adhesion.

The lateral emergency exit and double-wall structure have been adopted as it was done for the standard and special cross-sections. In addition, this element is dimensioned internally in order to allow an extra parking area which can be combined with parking space of the special elements. Furthermore, this element has been adopted with two toilet service room for the users and people inside the SFT. The distribution can be consult in the section 4.3.7 of this work.

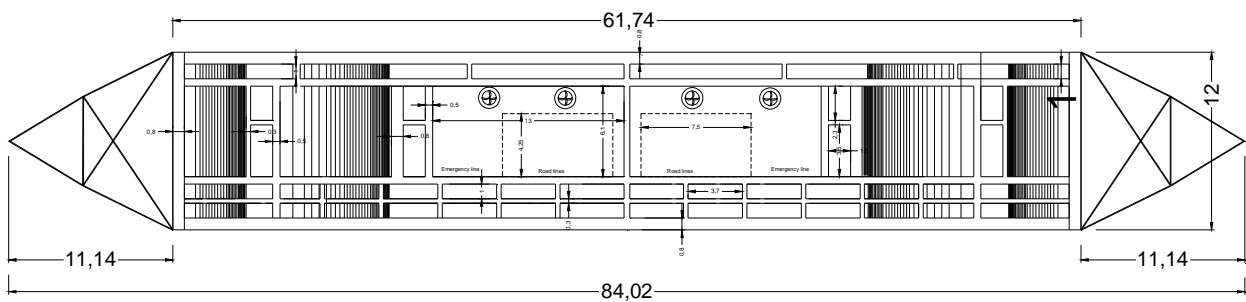

Transition cross-section proposed CS-T  
40 m long

Figure 4.23 Transition Cross Section of the Gulf of California (measures in meters)

The task for the transition module is to match the all the lateral walls as well as the double ceiling and road and bottom deck. Once this is achieved with both cross-sections, it can be considered a real transition element providing the longitudinal connection. The final design can be appreciate in the Figure 4.23.

The length of this element is established of 40 m in order to keep the residual buoyancy of the element in the design range. The buoyancy ratio range and loads are studied later on in section 4.3.2.

## 4.3. Structural Design Issues

### 4.3.1 Materials

The selection of materials for any project is one of the main decisions for the design and execution of the SFT. For structures with directly contact to the water, in particularly marine structures, is fundamental have the most convenient choice for the material to use.

In the case of the SFT many solutions and materials have been adopted worldwide, it being the most common concrete and steel as well as combination of both. As no SFT has been constructed around the world at the moment, until nowadays the most similar waterway crossings to SFT's technology are the precast tunnels settled on the seabed. The immersed tunnels technology (IMT) is a well known practice around the world and many projects have been placed in almost all the continents. As it was studied in section 2.4, are presented some variations in the different IMT projects, since the production, transport, and

placement and so on, but what it take place for this section, is the materials selections in the diverse projects. It is common than in North America is often use steel for IMT, being circular as well as rectangular cross sections. For other part in Europe is most common adopting the rectangular section made of concrete. While in Asia, a combination of both materials is used resulting type sandwich structures. All this solutions have advantages and disadvantage from different points of view. In the Table 4.9 are presented the main characteristics of each material proposed either for Immersed Tunnels as Submerged Floating Tunnel.

<b>Property</b>	<b>Steel</b>	<b>Concrete</b>	<b>Aluminum</b>
Mechanical Behavior in compression	good	good	good
Mechanical Behavior in tension	good	poor	good
Resistance to marine corrosion	poor	good	good
Resistance to fire and high temperatures	poor	good	poor
Weight	low	high	poor
Durability	good	good	good
Workability	good	good	good
Cost	medium	low	high

*Table 4.9 Property characteristics of considered materials for IMT and SFT projects*

In the last years the longest immersed tunnels have been realized of concrete and also the longest IMT project is would be made of concrete (see section 2.2.3.). Furthermore, the production method of the concrete elements have been improved to much since the starting of this practice, what it gives as result longer projects in shorter time. Thus, considering that the SFT proposed in the present work is around 143-km long, the concrete can be considered as the cheapest solution. Since those points of view the selection of concrete as manufacture material for the SFT elements has been taken.

In addition, considering the complex shape of the lateral devices designed for the cross sections and also the difficulty that represents collocate them during the erection step, the lateral advices are considered to be fabricated of steel. Thereby, the concrete and steel is used for fabrication of the elements in the SFT. The mechanical characteristic of these materials is presented in the Table 4.10.

<b>Material</b>	<b>Design Strength</b>	<b>Elastic Module (E)</b>	<b>Density</b>
Concrete C20/25	25 MPa	28848 MPa	2500 kg/m <sup>3</sup>
Steel S235	235 MPa	210000 MPa	7850 kg/m <sup>3</sup>

*Table 4.10 Mechanical Property of the used materials*

#### 4.3.2 Loads

The loads that are present in any Submerged Tunnels are the self weight loads, live loads and buoyancy. The self weight loads ( $W_D$ ) are considered the weight of the concrete, steel and facilities:

$$W_D = \gamma_c A_c + \gamma_s A_s + W_f$$

where:

$\gamma_c$  = specific weight of concrete

$A_c$  = concrete area

$\gamma_s$  = specific weight of steel

$A_s$  = steel area

$W_f$  = facilities weight

The Archimedes buoyancy ( $B_k$ ) is:

$$B_k = \gamma_w A_{tot}$$

where:

$\gamma_w$  = Water density. For the particular location of the northern part of the Gulf of California where the salinity is around 35.5 ppm (SEMARNAT), the density consider for this will be equal at 10.16 kN/m

$A_{tot}$  = Total area of the cross-section

Residual Buoyancy ( $RB_k$ )

$$RB_k = B_k - W_D$$

Buoyancy Ratio ( $B_kR$ )

$$B_kR = \frac{RB_k}{W_D + W_L}$$

where:

$W_L$  = estimated live load per unit length

It is important to remark that the Buoyancy Ratio under normal operations must satisfy the following condition:

$$1.2 \leq B_kR \leq 1.3$$

The design value of the buoyancy ratio has been evaluated considering the load combination under vertical dead and live loads valid for the Ultimate Limit State, defined according to the Eurocode 0 provisions [CEN, EN 1990, 2002] (Mazzolani et al., 2001).

In addition, there is another case for the residual buoyancy which is the maximum that can occur and the foundation and cables must be able to support it. It is presented when no live load is present in a SFT element. This is absolutely important for the design of the cables and the foundation that must have the capability of keep the SFT in the same place with a stable condition.

In the Tables 4.11 to 4.13 are summarized the acting loads of each cross-section type for the SFT in the Gulf of California. It is presented the weigh load, live load, buoyancy, and residual buoyancy for the normal and maximum conditions. Also is shown the buoyancy ratio for both conditions. These results are presented per unit length and for the total element. The Figures shows are only for illustrate the correspondence cross-section.

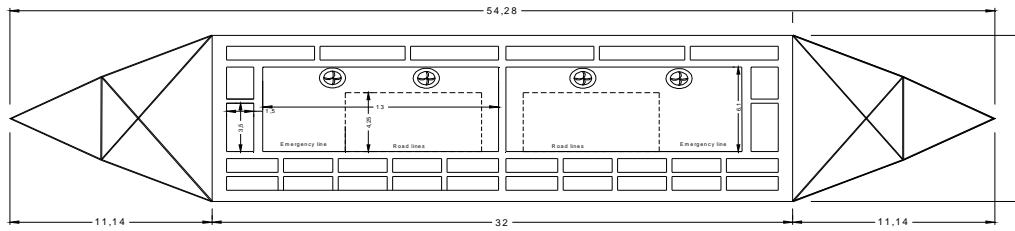

Standard cross-section proposed CS-D  
200m long

Type	Concrete Weight $W_c$	Steel Weight $W_s$	Facilities Weight $W_f$	Live Weight $W_L$	Archimedes Buoyancy $B_k$	Minimum Residual Buoyancy $RB_{min}$	Maximum Residual Buoyancy $RB_{max}$	Minimum Buoyancy Ratio $BR_{min}$	Maximum Buoyancy Ratio $BR_{max}$
Per unit length (m)	3,041.1 kN/m	408.2 kN/m	50.7 kN/m	720 kN/m	5329.02 kN/m	1109.02 kN/m	1829.02 kN/m	1.26	1.52
Per element (200 m)	608,220.00 kN	81,640.00 kN	10,140.00 kN	144,000.00 kN	1,065,804.00 kN	221,804.00 kN	365,804.00 kN	1.26	1.52

Table 4.11 Design load acting on the standard cross-section (CS-D)

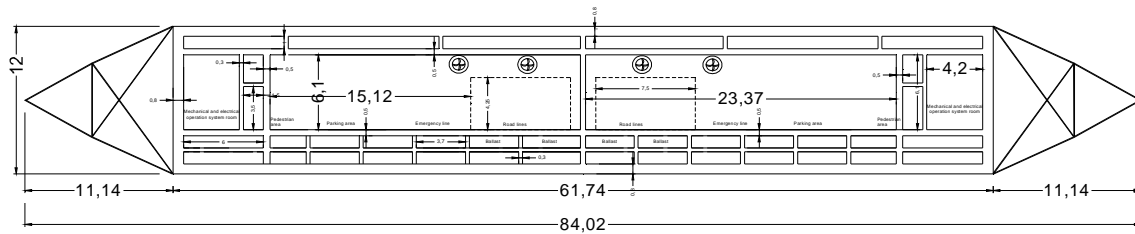

Special cross-section proposed CS-SD  
100 m long

Type	Concrete Weight $W_c$	Steel Weight $W_s$	Facilities Weight $W_f$	Live Weight $W_L$	Archimedes Buoyancy $B_k$	Minimum Residual Buoyancy $RB_{min}$	Maximum Residual Buoyancy $RB_{max}$	Minimum Buoyancy Ratio $BR_{min}$	Maximum Buoyancy Ratio $BR_{max}$
Per unit length (m)	5,603.07 kN/m	408.2 kN/m	100 kN/m	1000 kN/m	8955.51 kN/m	1844.239 kN/m	2844.239 kN/m	1.26	1.47
Per element (100 m)	560,307.10 kN	40,820.00 kN	10,000.00 kN	100,000.00 kN	895,551.00 kN	184,423.90 kN	284,423.90 kN	1.26	1.47

Table 4.12 Design load acting on the special cross-section (CS-SD)

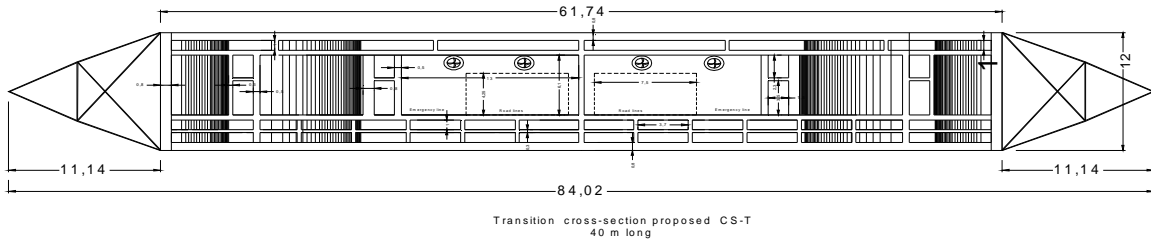

Type	Concrete Weight $W_c$	Steel Weight $W_s$	Facilities Weight $W_f$	Live Weight $W_L$	Archimedes Buoyancy $B_k$	Minimum Residual Buoyancy $RB_{min}$	Maximum Residual Buoyancy $RB_{max}$	Minimum Buoyancy Ratio $BR_{min}$	Maximum Buoyancy Ratio $BR_{max}$
Per unit length (m)	Not available for Varied Cross-Section								
Per element (40 m)	163,323.98 kN	16,328.00 kN	2,028.00 kN	28,800.00 kN	273,910.55 kN	63,430.57 kN	92,230.57 kN	1.30	1.51

*Table 4.13 Design load acting on the transition cross-section (CS-T)*

#### 4.3.3. Anchorage system

As it was defined at the beginning of this chapter, the SFT of the Gulf of California is anchored on the seabed by gravity foundation. This means that a group of cables are necessary to connect the Submerged Floating Tunnels with the foundation. So the cable system must be able to resist all the tensile axial force generated by the residual buoyancy of the SFT. Thereby, the cable design must be done considering the maximum residual buoyancy of each element.

As it was study in section 4.1.4, the configuration of the cable system is based on the study made by Martire (2007). In the Figure 4.14 can be consulted the cable configuration for SFTs which assure better stability. The Figure 4.24 illustrates the anchorage system adopted for the cross-section defined for the SFT of the Gulf of California. This figure has as objective show the location of the foundation with respect to the SFT modules as well as the cable system proposed. It is notorious than the distance will varied according the depth of the crossing.

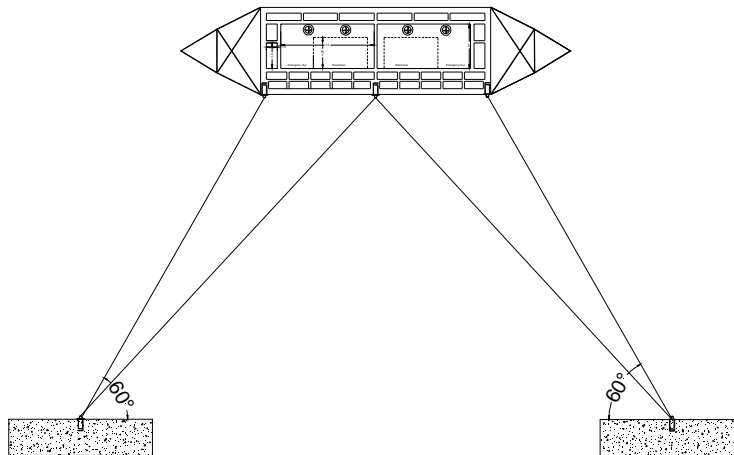

*Figure 4.24 Transversal anchorage configurations*



On the other hand, it is considered a total of four anchorage system along the longitudinal axis per each standard element. This means that a total of 16 cables are supported the 200 m element what it would lead to constant spans of 50 meters between each anchorage system as it can be appreciated in the Figure 4.25.

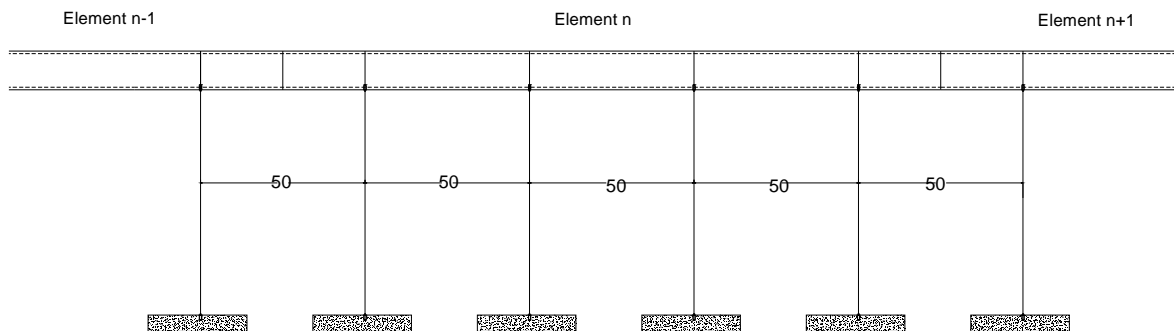

Figure 4.25 Longitudinal anchorage configuration

Moreover, the special element which is 100-m long is considered to be supported by 3 anchorage systems in order to have roughly the same span between systems. Resulting spans of 45-m long for special modules, which is also the same distance given for transition elements which are supported just for one anchorage system.

Once that are defined the cable system for each element, are calculated them as preliminary stage considering just the tensile forces. In the Table 4.14 is summarized the design values for the cables. The technical information of the cables is based on the product offers by a company of the United Kingdom, named *Bridon*, which is one of the leaders in the field.

Cable Design							
Cross-Section	Maximum Residual Bouyancy per element (kN)	Total of cables per element	Strenght per cable (kN)	Safety Factor	Design Strenght per cable (kN)	Cable diameter (mm)	Cable Minimum Breaking Load (kN)
CS-D	365,804.00	16.00	22,862.75	1.30	29,721.58	180.00	31,000.00
CS-T	92,230.57	4.00	23,057.64	1.30	29,974.93	180.00	31,000.00
CS-SD	284,423.90	12.00	23,701.99	1.30	30,812.59	180.00	31,000.00

Table 4.14 Cable design loads

In conclusion the cables to be used in the SFT of the Gulf of California are registered with the product code: *LC 180*.

#### 4.3.3.1. Connection Details

Another important issue that might be analyzed with carefullness is connection of the cables with the tunnel and the foundation. It is clear than if the connection details fail, the SFT will fail with the same consequences as a cable fail.

For this case, two different connection devices have been considered. One device is embedded in the tunnel structure and foundation, while the other special socket is assembled in both extreme of the cable. And so can be put together during the erection step.

The placed mechanism in the SFT and the foundation is formed by a steel plate, anchored with steel rod in the concrete of both structural elements. So then a steel ring is welded to the plate assuring the union between both elements. This joint must be highly verified during the execution to ensure the link resistance. These elements can be used in the SFT structure and in the foundation. The detail of the mechanism is shown in the Figure 4.26.

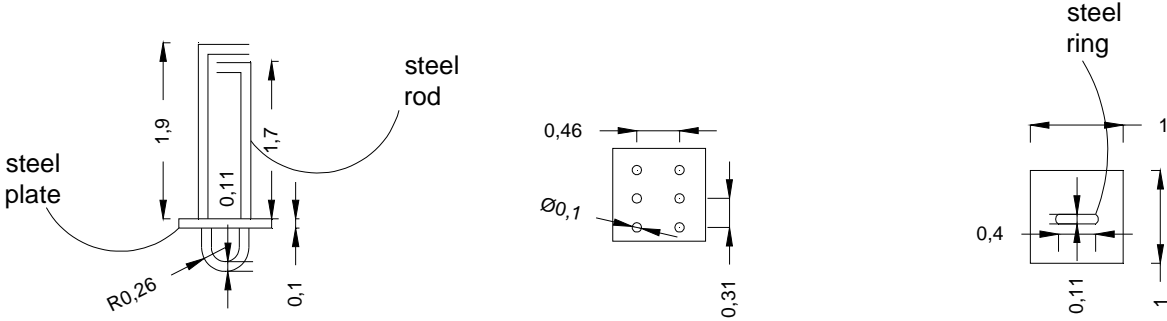

Figure 4.26 Details of the embedded connection

On the other hand the device to be used in the cable extremes are structural sockets often using in bridges or others structures where the cables work in large axial forces.

For this case again is consulted the different products offered by specialized companies in the world. The most suitable product for the case is offered by the same British company than the cables. This product is a Stylite Fork Sockets (ST-F). Thereby, considering the diameter of the selected cables of 180 mm, the product code selected is the ST-F 60. The characteristic of this device is show in the Figure25.

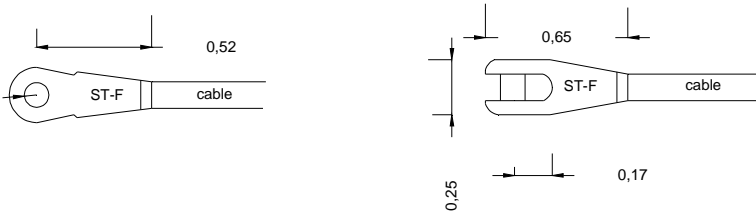

Figure 4.27 Devices for connecting the cables with the embedded connections

#### 4.3.4. Foundations

As it was established before, gravity foundations are adopted for supporting the elements of the SFT. These elements follow the same configuration defined for the anchorage system. As it is defined in the Figure 4.24, are necessary two blocks per each cable system. The foundation elements as well as the cable must be designed with the maximum residual buoyancy that is present when not live load acts in an element.

The foundation consist in concrete boxes that that are precast in a dry dock, and then because of their own buoyancy capacity are transported until their correspondance project site. Once the elements are in the correct location, are filled with ballast concrete to produce the sinking until the seabed. Finally, they can act as gravity foundation once is reached the weight of design. In the Figure 4.28 is schemed this sequence. The devices for the connection with the cables have to be placed during precast in the dry dock for ease constructability.

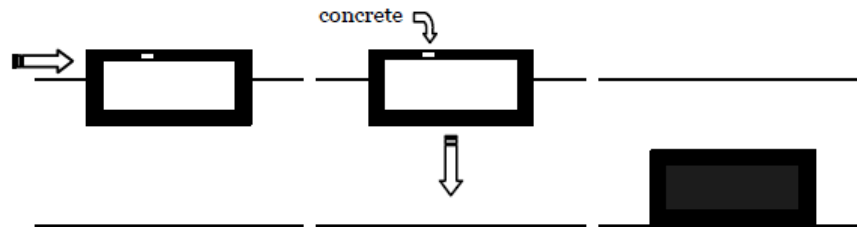

Figure 4.28 Sequence of the foundation fabrication (Mazzolani et al., 2007)

Moreover, the foundation design has to consider an optimal geometry which can be manageable during the fabrication as well during the erection. Furthermore, it has to be caring the spaces between the different anchorage system, both longitudinal and transverse. The latest concern is in shallow waters when the low depth could cause interferences because the dimension of the blocks.

Taking in account the last aspects, the design loads as well as dimensions of the blocks are presented in the Table 4.15.

Foundation Design												
Cross-Section	widht (m)	lenght (m)	height (m)	volumen (m3)	ballast unit weight (kg/m3)	Weight (kg)	Weight (kN)	N° of blocks	Total Weight (kN)	Safety Factor	Design Weight (kN)	Maximum Residual Bouyancy (kN)
Foundation CS-D	15.00	25.00	8.00	3,000.00	2,500.00	7,500,000.00	73,575.00	8.00	588,600.00	1.60	367,875.00	365,804.00
Foundation CS-T	15.00	25.00	8.00	3,000.00	2,500.00	7,500,000.00	73,575.00	2.00	147,150.00	1.60	91,968.75	92,230.57
Foundation CS-SD	15.00	25.00	8.00	3,000.00	2,500.00	7,500,000.00	73,575.00	6.00	441,450.00	1.55	284,806.45	284,423.90

Table 4.15 Foundation Design Loads

From the table 4.15 can be appreciated the uniformity in the dimensions of the blocks. Foundation blocks with a dimension of 15mx25x8m are an acceptable design for being used in each of the elements even when the maximum residual buoyancy is bigger that the weight design of the element, specifically for the cases of the section CS-T and CS-SD. But despite that, the real weight of the block is much bigger than the maximum residual buoyancy, and the safety factor still remains up of 1.5. This uniformity of size became more important during the construction step relative with cost as well as the schedule. Standardized elements can be fabricated in a single line production instead three line production in the case of distinct blocks geometry for each type of SFT element. The Figure 4.29 shows the dimensions of the standardized block.

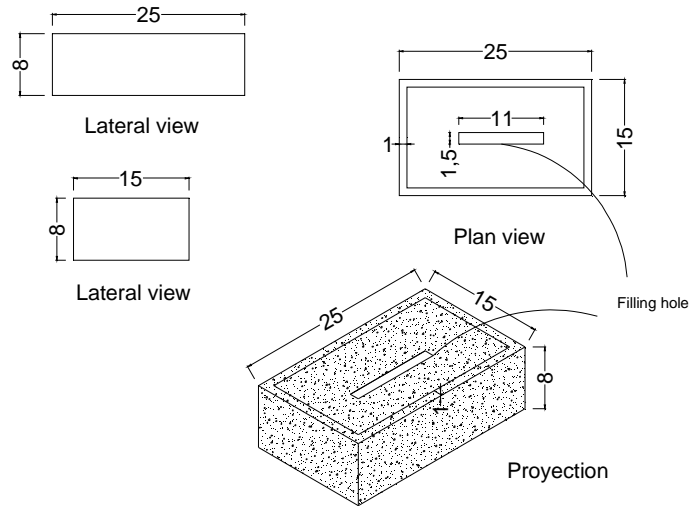

Figure 4.29 Foundation elements (measures in meters)

#### 4.3.5. Joints

##### 4.3.5.1. Inter-modular joints

A Submerged Floating Tunnel is a modular precast structure fabricated in a dry yard and ensemble in situ. The connection between the elements is fundamental for the behavior of the SFT. It is fundamental has rigid connection between the elements and allowing displacements at the shore connection.

In this case is adopted the technology of immersed tunnels. This is a really good solution which allows the ease during the placement of the elements. The use of Gina gasket as well as omega seal will be proposed as solution for inter-modular joint of the SFT of the Gulf of California. The normal practice for immersed tunnels that can be adopted for SFT is described here below.

The Gina gasket is used as a temporary seal at the installation stage and remains as a flexible compression seal for the permanent stage. The facing tunnel element ends are lined with steel plates that are matched as parallel planes. Then the omega rubber water barrier is installed at the dewatered joint by bolting it to the inside faces of the two tunnel elements. The space between the Gina gasket and the Omega seal is usually drained off to the inside of the tunnel, providing a direct indication of the performance of the outer gasket. The Gina-type gasket acts as a flexible joint under compression, and can practically be considered as a hinge in longitudinal moment transfer (Grantz et al. ,1997). The steps of this process are schematized in the Figure 4.30.



Figure 4.30 Construction steps of the joint between elements (Trelleborg Baker, 2008)

The details of the joints for the modules of the SFT are show in the Figure 4. 31

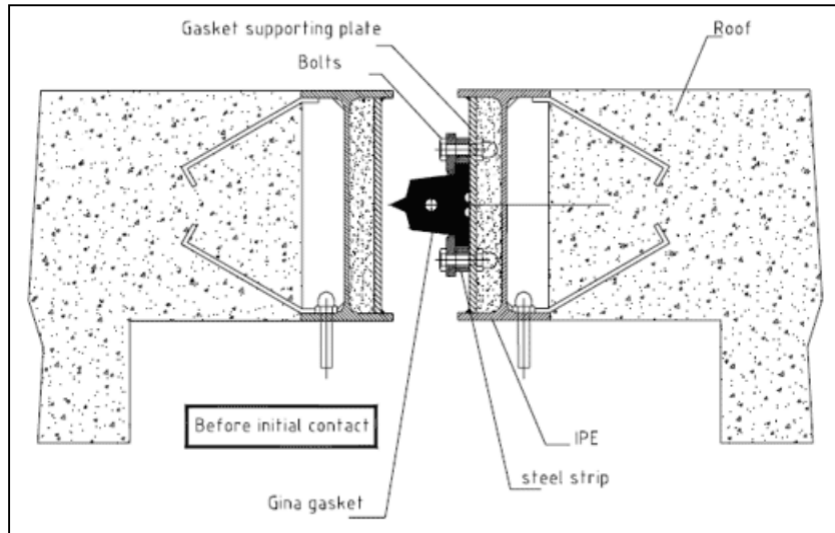

Figure 4.31 Details of the inter-modular joints (Bistoon Baspar LTD)

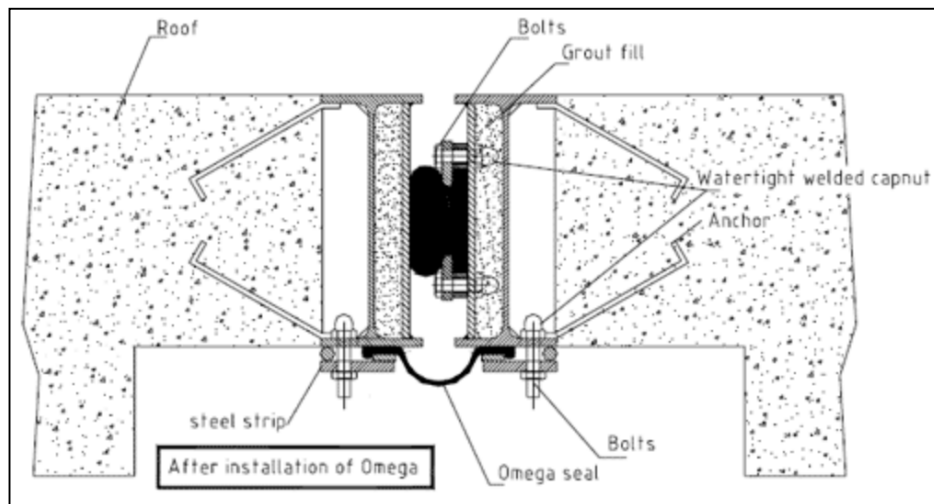

Figure 4.31 Details of the inter-modular joints (Bistoon Baspar LTD, continuation)

#### 4.3.5.2. Shore Connections

Considering the great length of the SFT proposed, the displacement and the affectations produced by natural events must be considered as local issues. For these fact in both cases of the shore connection has been consider and special mechanism that allow free rotation and axial displacement.

The special joint that it is adopted is the proposed for the AB prototype in the Qiandao Lake, China (Mazzolani et al, 2007). The shore joint give to the structure the possibility of free expansion in presence of thermal variations as well as assure the water tightening. The general concept is based on separating the

waterproof and mechanical functions of the device. The conceptual design as well as the solution system can be appreciated in the Figure 4.32. In addition, the design of the solution is shown in Figure 4.33.

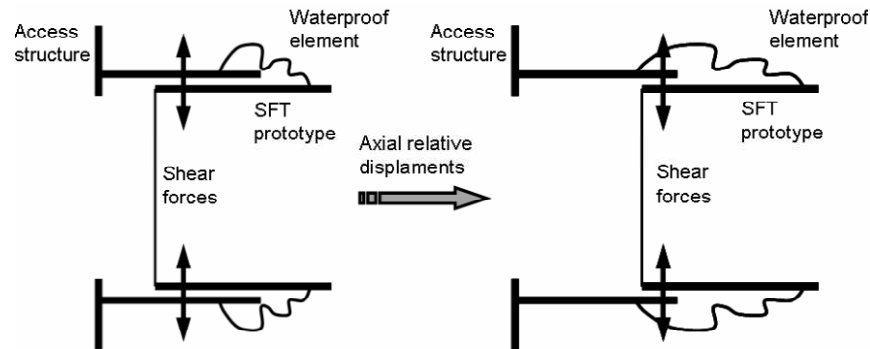

Figure 4.32 Conceptual design for the shore connection (Mazzolani et al., 2007)

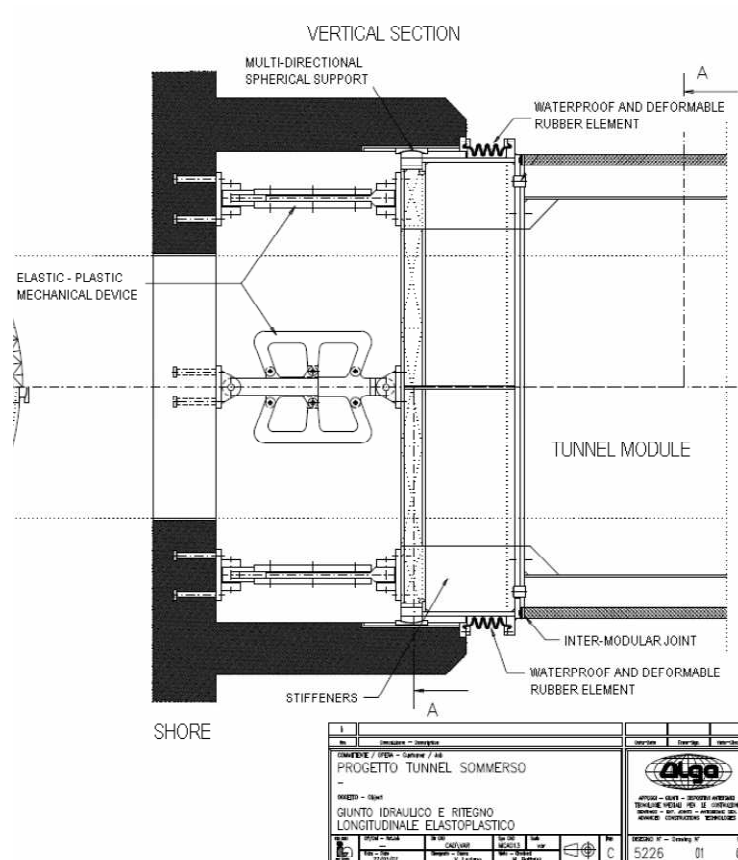

Figure 4.33 Design of the shore connection joint (Mazzolani et al, 2007 and ALGA)

#### 4.3.6. Access Structure

The access to a Submerged Floating Tunnel has been being discussed in many publications for the different proposals around the world. It cannot be normalized a single access structure as solution for all the SFTs. The decision for the suitable connection at the shores or in occasion in water is related principally with the

purpose of the SFT (railways, roadways, pedestrian or combination of these) as well as the topography in the shore and the location depth of the SFT. Usually SFTs are proposed to be located between 25 and 30 meters under the mean sea level, which it means a big height for short distances.

For the SFT of the present work, they were studied different options for the shore access. Firstly it was attempted to link the Submerged Floating Tunnel with a conventional immersed tunnel, but this solution was not possible once that the bathymetry was studied. The water is too shallow at the SFT location (seabed profile TD-1), so if an immersed tunnel is placed in that area the minimum required clearance for shipping over the IMT would be not enough for allowing pass the vessels for the region. As solution it was thought to dredge the area for achieve the minimum clearance at the top. But later the solution was discarded because should be dredged an area about 1,120,000 m<sup>2</sup> with depths from 1 to 5 meters what it becomes the project unfeasible.

Other solutions were to connect the SFT by bored tunnels at the shores. The solution would result with really long bored tunnels that according the regulations of the maximum gradient allow for tunnels, it would add around of 20 km more to the 143.4 km SFT. Furthermore, the joint of the SFT with the tunnel would require of very complex structure in order to ensure the waterproofing inside both tunnels as well as absorb the different displacements generated.

In addition, an immersed tunnels supported on piers was implemented as solution of shore connection. Unfortunately, the topography was not favorable neither for this configuration. The Figure 4.34 shows this scheme.

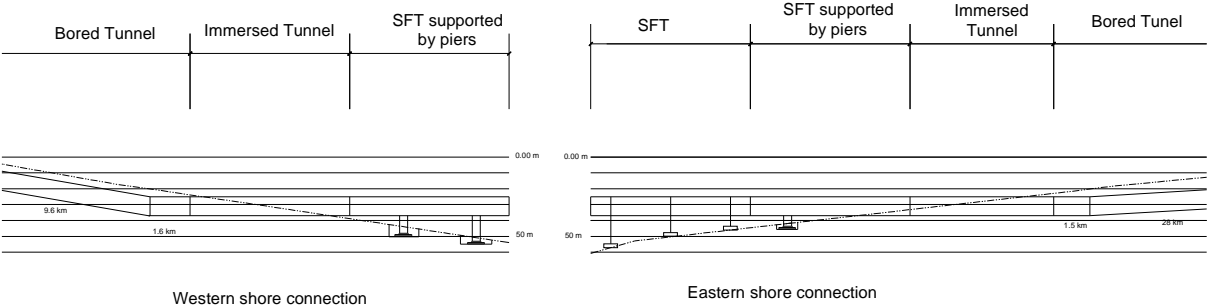

Figure 4.34 Bored Tunnel as access structure

Another solution was the employ of a special ramp proposed in the Archimedes Bridge prototype on the Qiandao Lake in China. It consists of a helicoidally access which allow connect a road over the mean sea level with a SFT with a considerable location depth.

In order to approach the maximum of this solution, it was proposed the combination of a bridge with the SFT. With this combination the main achieve is the reduction of the length of the SFT from 143 to 112 km. It is obviously that for the users is better driving in open spaces than in tunnels. Thus, the scheme for the solution adopted is schematized in the Figure 4.35.



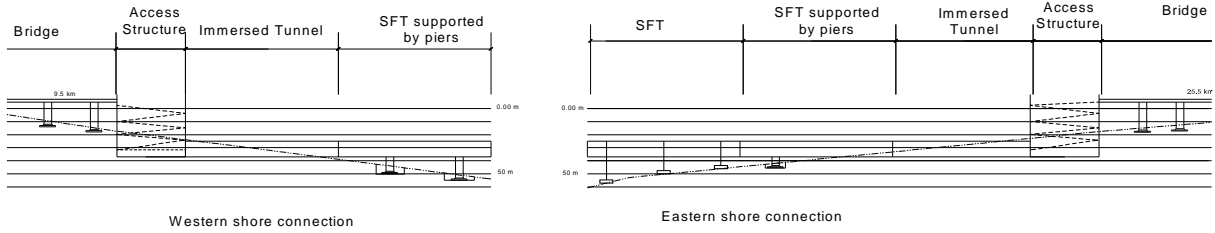

Figure 4.35 Bridge and helicoidally ramps as access structure

Thereby the latest solution has been adopted as access structure. Thus, the preliminary design was carried out. The geometrical design is based on the Mexican codes (Handbook of road geometrical design-SCT). The design of the structure consists in just two road lines, one in each direction. Furthermore, it allows the pass of heavy trucks even when two of these vehicles cross the structure at the same time. In addition, the gradient for the road deck of the access structure must allow driving heavy trucks with any inconvenient according the regulations. The result of the geometrical design is shown in the Figure 4.36.

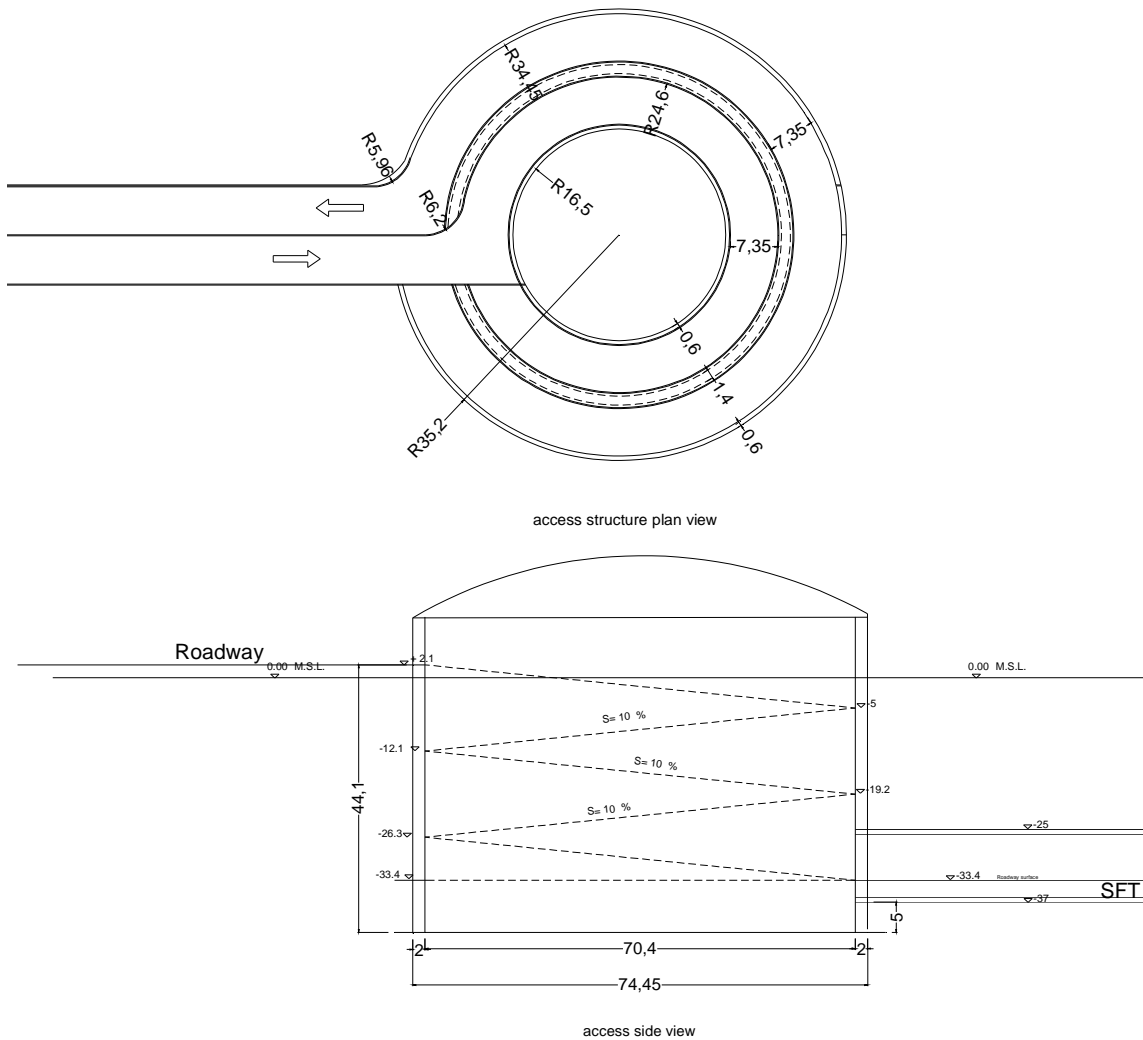

Figure 4.36 Geometrical design of the access structure

Furthermore, in order to obtain the geometry of the structural components it was carried on preliminary design. This is shown in the Figure 4.37.

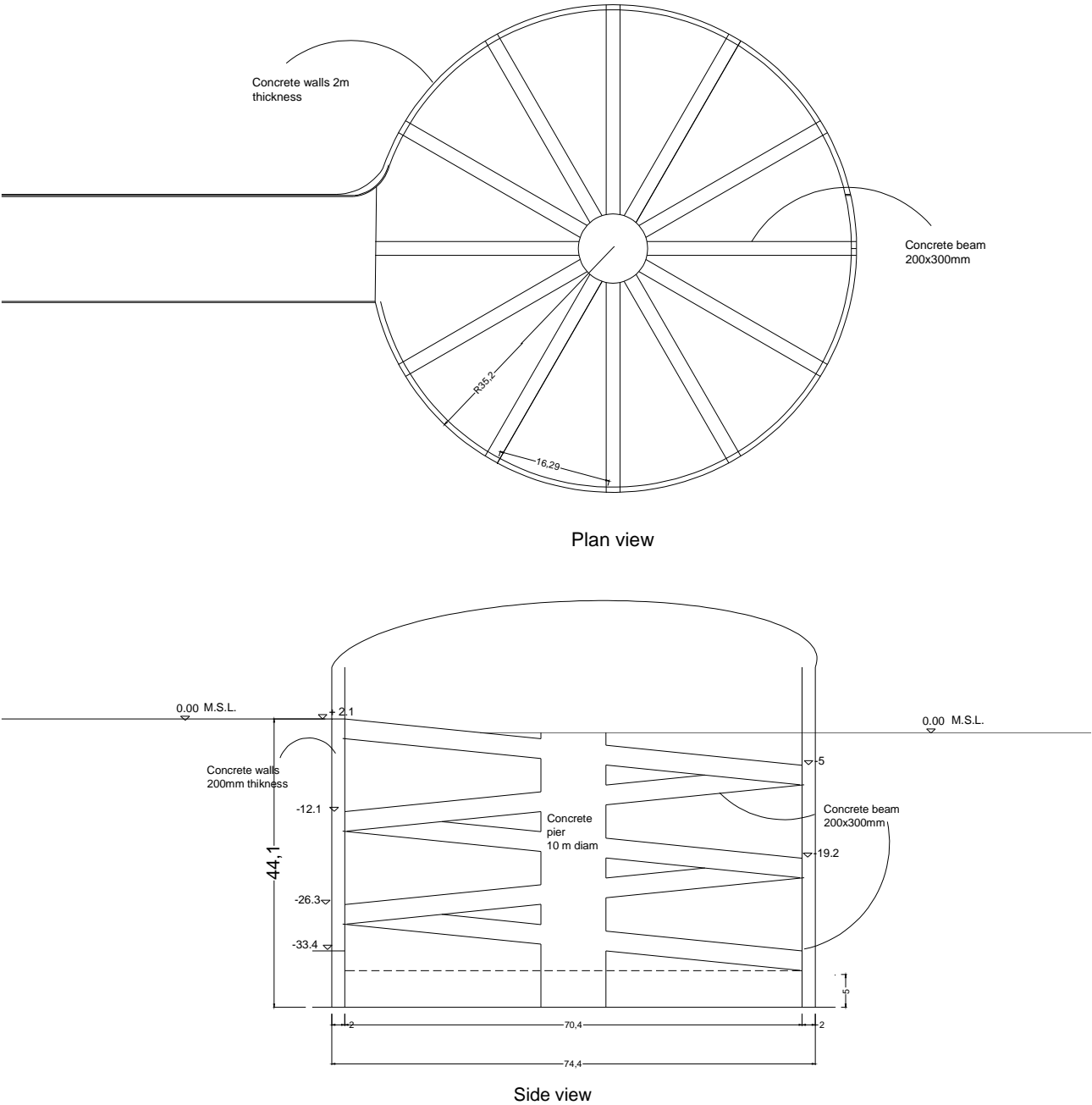

Figure 4.37 Structural solutions for the access structure

#### 4.3.7. Towers and service platform

Nowadays the safety is the main aspect to take in account in tunnel design. This concern must be taken in account since the beginning step of the geometry design of a tunnel. These types of link ways are getting safer day after day by the fact that these are becoming in longer structures. Whatever the typology of tunnel is such as subsea, immersed or a simply road tunnel, new improvements around the world have been adapted. The reality is that a tunnel must be safer roadway than open air roads. It has to provide the enough confident for the users that drive on it especially in long tunnels.

The cases of Submerged Floating Tunnels are not the exception. The external configuration of the structure is really different than conventional tunnels. Moreover, inside of a SFT could be considered a tunnel, with an extra concern that the structure is surrounded by water. This last issue could be scared for some people, thus some distracters during a long journey could be beneficial for helping to forgot the outer scenario.

More complex becomes the idea when the considered structure is 112-km long. This length is around two times longer than the longest tunnel in the world at the moment (St Gotthard base tunnel, 57 km) but it is import remark than this is a railway use. Moreover, the longest road tunnel in the world nowadays is the Laerdal Tunnel with 24.5 km which is more comparative with the SFT of the Gulf of California since the point of view of use. A fact is that the SFT proposed in this work is about 4.5 times longer than the Laerdal Tunnel.

Considering the great length as well as the floating condition, since the beginning was considered special structures for evacuation and resting. This consists in towers which guide outside of the SFT. The evacuation towers are provided with platform at their top where can be find a restaurant, shopping or simply relaxing area for breaking the monotony of the long journey. As well these platforms at the roof floor are provided with heliports for evacuating people in case of incidents. It is proposed a total of 8 towers and 4 platforms due to 2 towers support one platform. The location of these structures is shown in the Figure 4.38.

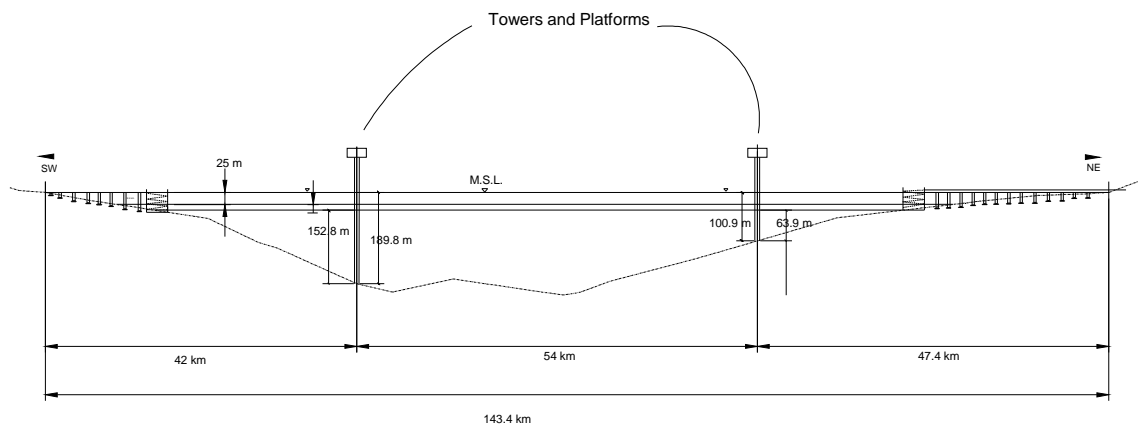

Figure 4.38 Location of the towers and platforms along the SFT

The dimensions and details of the towers and platforms are presents here below in the Figures 4.39 to 4.42.

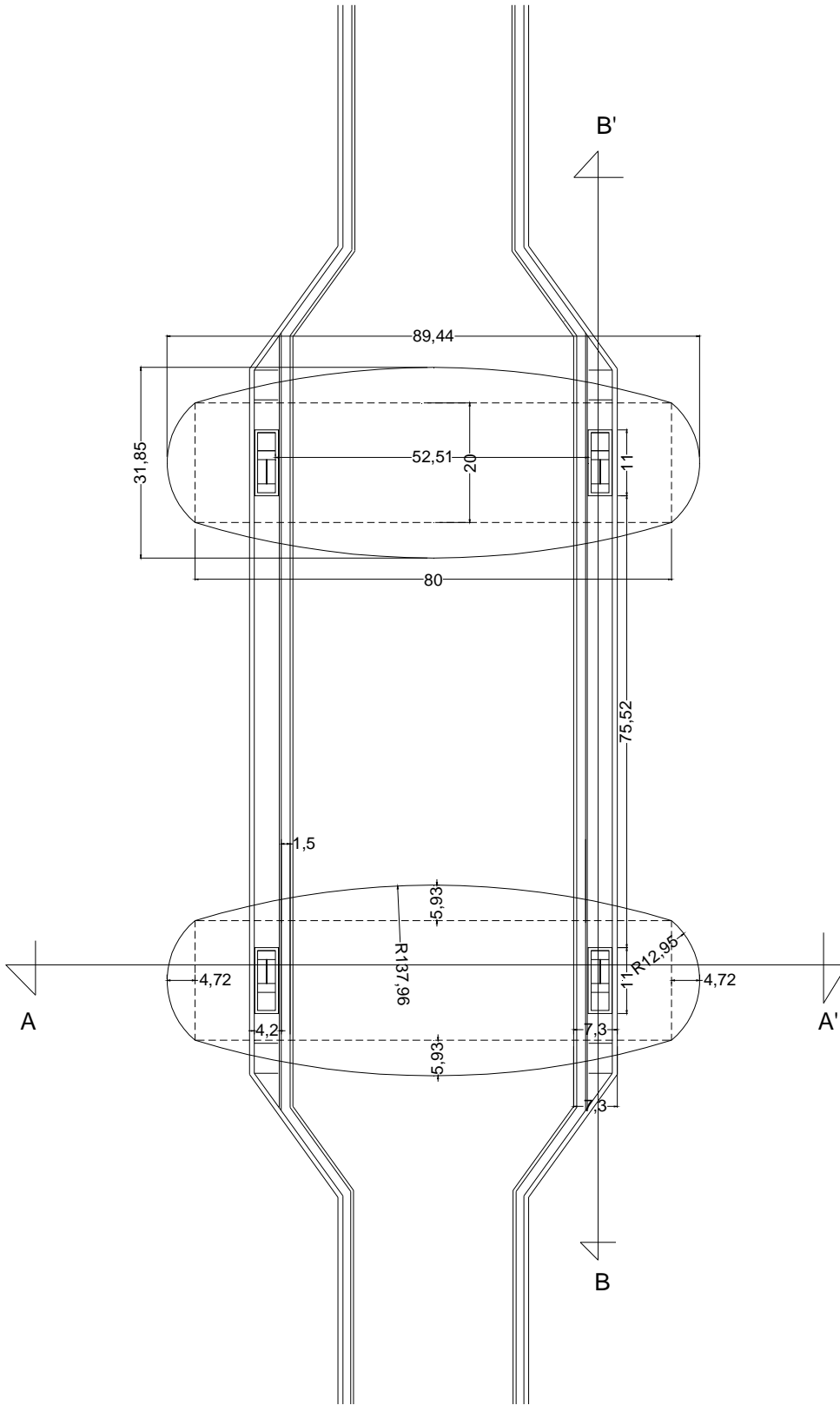

Figure 4.39 Tower locations and platform geometry in the special cross section (measures in meters)

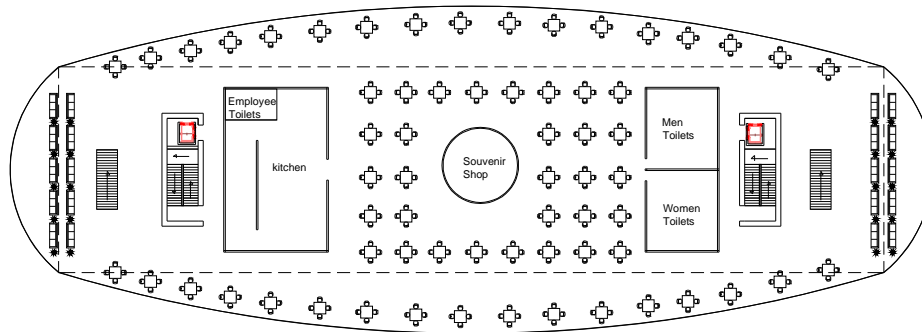
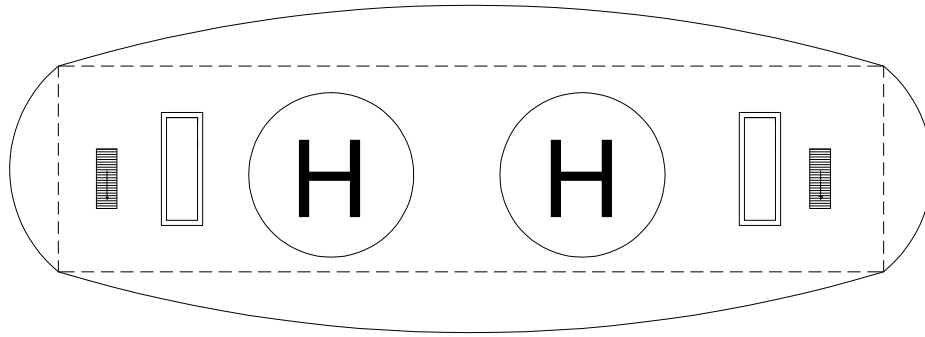

Figure 4.40 Distribution of the platform at the first and second floor

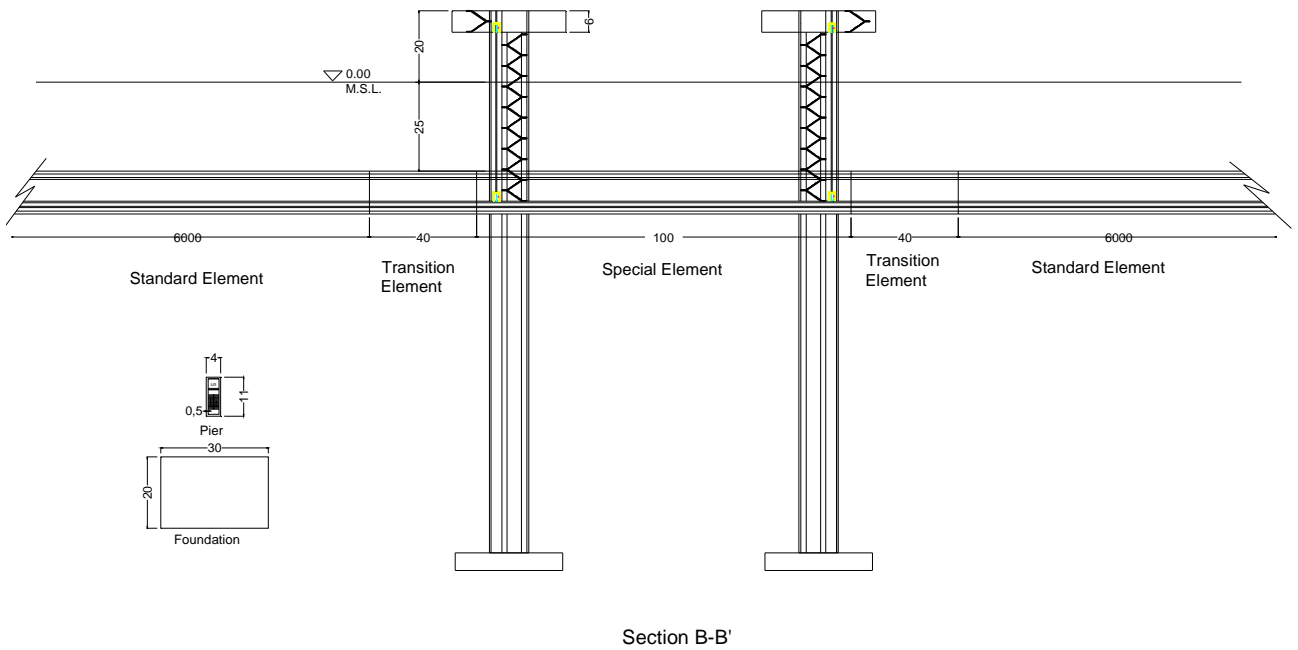
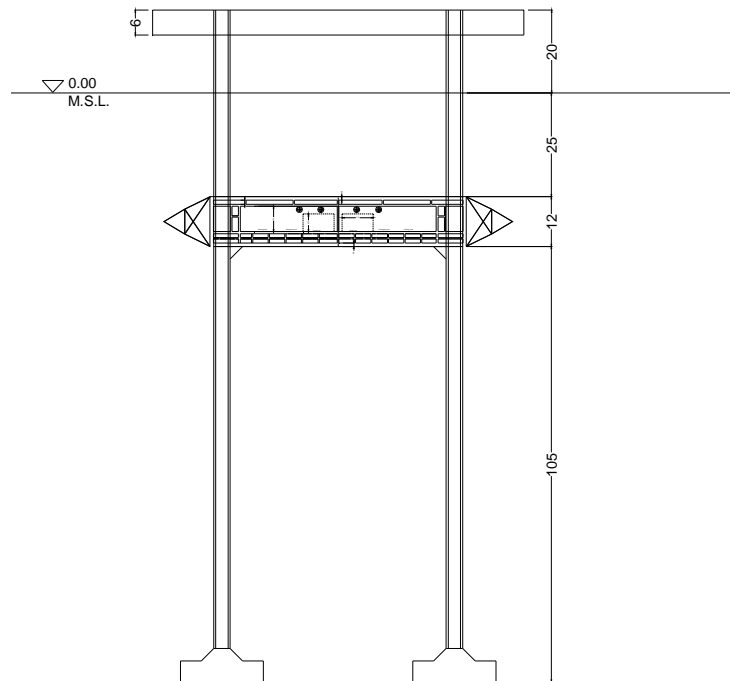

Figure 4.41 Longitudinal view of the towers and platforms (measures in meters)



Section A-A'

Figure 4.42 Transversal view of the towers and platforms (measures in meters)

#### 4.4 Safety

The safety on the SFT of the Gulf of California is designed according to the requirements and regulations around the world studied in Section 2.3 of this work. The design involves some consideration from section 2.2 of the different typology of tunnels around the world. Due to the destination of use of the SFT of the present work, the interest is mainly in the requirements for road tunnels and immersed tunnels. Furthermore, taking into account the concrete immersed tunnels with rectangular shape, it seems to be the starting point due to the similar structural arrangement to this proposal.

##### 4.4.1 Structural measures

It is important to design the longitudinal distribution inside the tunnel before established the main structural arrangements of safety such as: emergency exist, evacuation, drainage, and so on. Taking into account the great length of the SFT, the safety is mainly concerned on the self-rescue aspects. The emergency corridors for pedestrian as well as the first aids modules are some of the issues which are most caring for safeness. A fact is that this longitudinal design has been realized in parallel to the cross-section design and different changes were done during the process (compare with Figure 4.18). Thereby, in this section is presented the longitudinal distribution with the definitive cross-section design. As it was studied in section 4.2 there are a total of three different elements along the SFT of the Gulf of California. Each of these elements have their

special function either in the service operation as well as in case of emergency. In Figure 4.44 is schematized the longitudinal distribution of the three cross-section types that were designed in the section 4.2. Due to the standard cross section is constant along the tunnel and just every 6 km is presented the special cross-section, the details of the Figure 4.43 are focus when wider section is placed and also when the towers are located in this special cross-section, what in consequence include the transition cross-section as well.

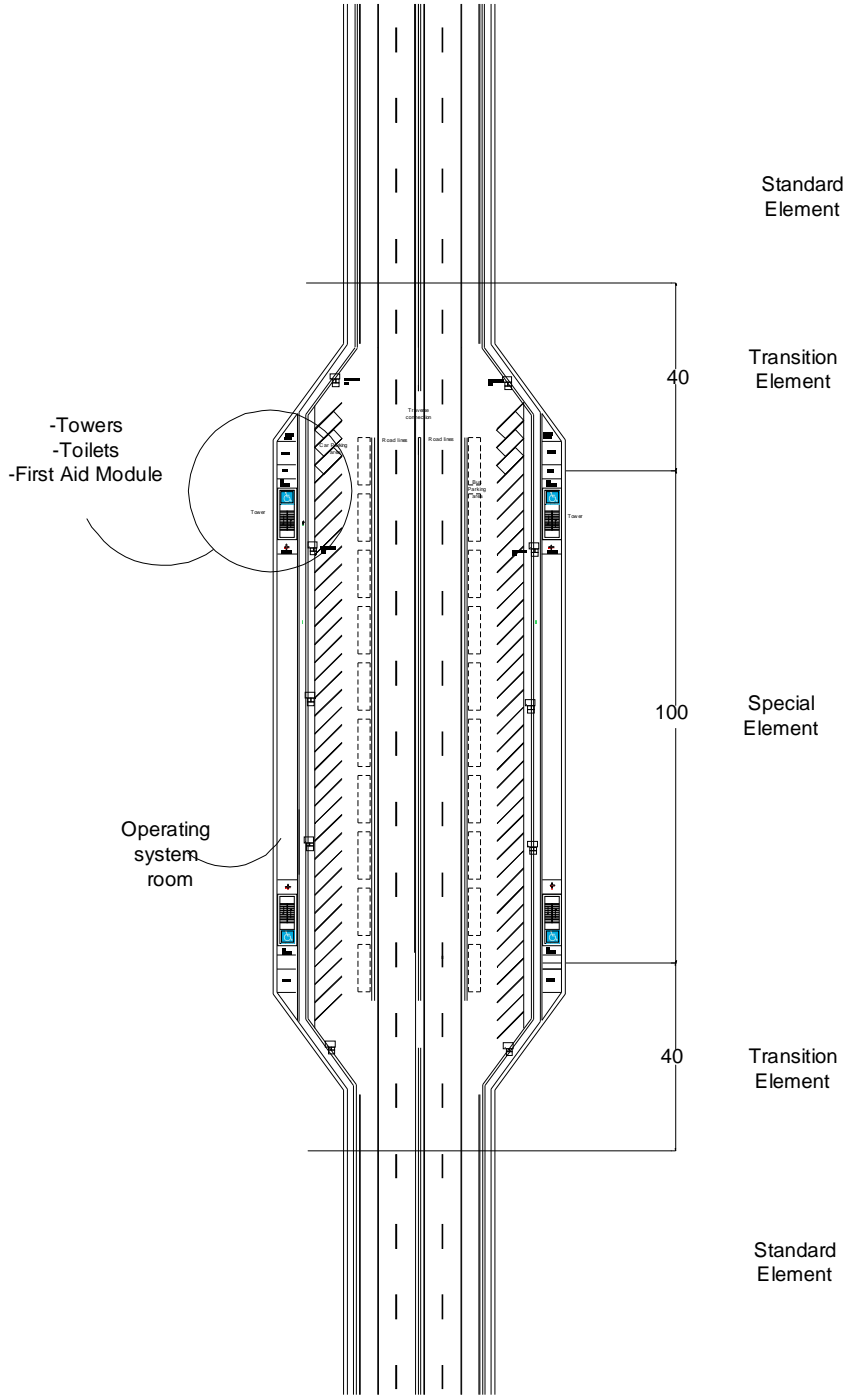

Figure 4.43 Longitudinal distribution of the SFT of Gulf of California at the towers location



The description of each element is described here below:

- a. The standard cross-section (CS-D). These elements are placed along the whole Submerged Floating Tunnel. The long of each element is 200 m. The internal geometry contents two road lanes in each direction and in addition an emergency lane at each side. A wall divided both traffic directions where a drive passage is placed every constant distance. The emergency exits are connected with a lateral pedestrian passage. The facilities are placed at the ceiling and in the intermediate gap at the bottom. It allows the parking for all type of vehicles.
- b. Transition cross section (CS-T). It is used just as a joint between the standard and the special elements. It has a length of 40 m with a varied width. At each extreme has the geometry of the especial and standard elements. Furthermore, in has an extra parking space that is combined with the major parking area of the special element. An area for toilets has been provided for this element as well as a ballast room for meeting the design buoyancy ratio. The pedestrian emergency passage continues from the standard cross-section through the special cross-section and also to the evacuation towers when is the case. In addition an emergency exit is provided.
- c. Special cross section (CS-SD). It is a 100 m long element. It contents additionally to the components of the standard elements a lateral extra space has been provided. The space contents a parking area for cars and buses. No heavy trucks are allowed to use it. There are five emergency exits connected to the lateral corridor. In the cases when the towers are placed this corridor is the way for use them. There are a special space for housing the mechanical, electrical and ventilation system. The tunnel operating room is located at each side of the element. Four rooms for first aid have been provided and also can work as emergency niches. There is assigned and special space for placed the towers and the mechanical room of the lifts. When not towers are placed, this space can be adopted as ballast room in order to decrease the residual buoyancy of the element.

In the Figure 4.44 can be appreciate the location of the different components placed for each element of the SFT. The Distribution of toilets and first aid model is shown in figure 4.45. In addition, in the Figure 4.46 is shown the distribution of the operation system room for the special element. Note that it is a double floor room.

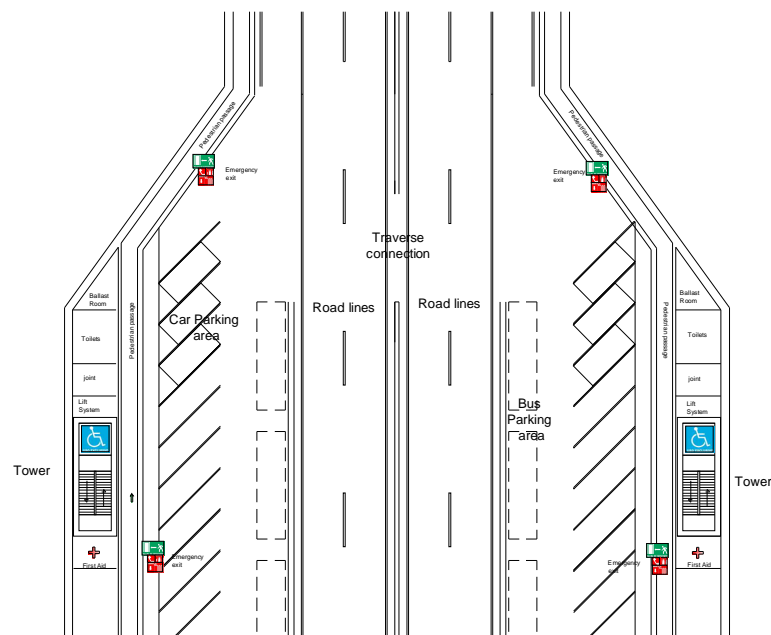

Figure 4.44 Location of the components for the SFT

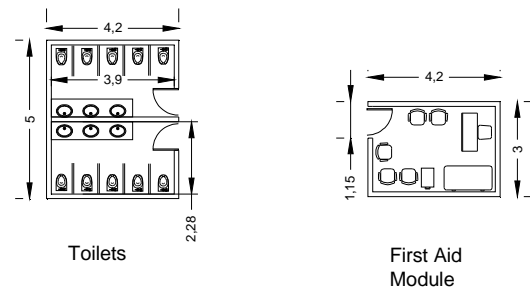
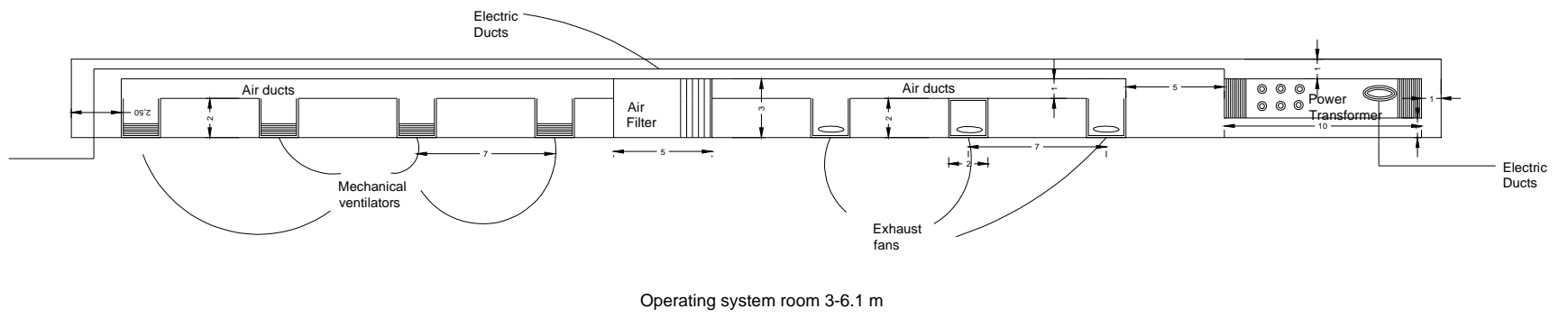
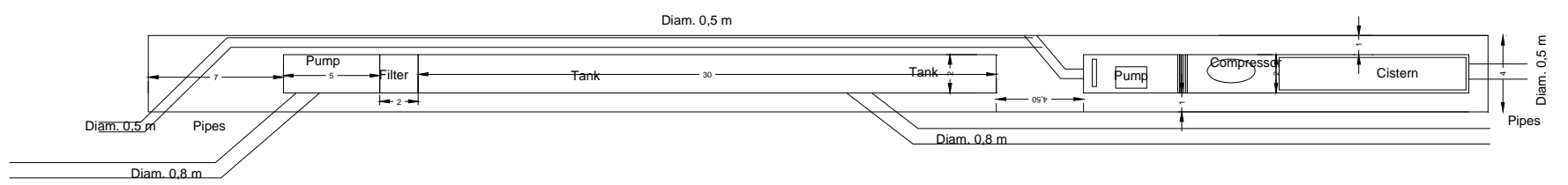

Figure 4.45 Distribution of toilet and first aid module



Operating system room 3-6.1 m



Operating system room 0-3 m

Figure 4.46 Distribution of the operation system room

#### 4.4.1.1. Road lanes

There are a total of two road lanes in each direction. The width of traffic lane is 3.75m with a width traffic lane marking of 15 cm. Thus the width of carriage is 7.50 m as is common in tunnel practice is Germany and Sweden. Therefore, the speed limit for the SFT is 110 km/h. With the width lane each road lane has a capability of transport 2200 vehicle/hour.

On the structural point of view, the lower part of the walls will be protected by New Jersey barriers which would provide more safety of the SFT structure against internal vehicle impacts. In addition to keep drivers from being inattentive or falling asleep, each lane is supplied with a loud rumble strip toward the center. In addition all tube ceilings, and the top of the walls, are covered with fire insulation (Fendolite) designed to withstand a fire impact of 1,350°C for two hours.

#### 4.4.1.2. Parallel escape tube

It is consider a passage along the whole tunnel as it can see in Figure 4.43. This corridor is destined for pedestrian use where drivers can get into it through the emergency exits. The tunnel of escape has a rectangular shape with dimensions of 1.5m width and 3.5m high. In the different cross-sections design can be appreciate this lateral structure which is protected either for the double wall system and the lateral devices.

#### 4.4.1.3. Emergency exits

The emergency exits are located at the right side of the tunnel. This are placed in constant intervals of 100m in the standard elements. Moreover, in the especial elements there are a total of three emergency exits placed every 35 m while in the transition elements another escape option is placed. The dimensions of the doors are 1.2m width and 2.5 m high. In addition it must be completely illuminated and painted by green color. In addition it must be fully signaled. The general configuration the emergency exits can be appreciated in Figure 4.47.



Figure 4.47 Configuration of the emergency station of the SFT of the Gulf of California (PIARC)

#### 4.4.1.4. Cross-passage

The SFT cross-section can be defined as two unidirectional tunnels divided by a wall at the centre. Thus, in case of emergency is necessary to cross this wall for change the direction to get away from the accident. Thereby, the cross-passage of the SFT allows the passage of all type of vehicles. These crossing gaps are

placed at intervals of 1500m along the tunnel. In addition each especial cross-section is provided of cross-passages for use in case of return to the same direction (Figure 4.44).

#### 4.4.1.5. Emergency lane

Due the lay-bys option was discarded during the design of the cross-sections, an emergency lane was implemented at each side of tunnel. Different from some design manuals, concerning the great length in this SFT proposal, the width of the emergency lane was decided to dimensioning equal to the road lanes (3.75m). In addition 50 cm are provided for open the doors without cause any interruption to the road lane operations. Thereby, with the total dimension of the emergency lane, is allowed to parking heavy trucks in any point of the SFT without consequences to the traffic operation. This solution would certainly decrease the accidents where heavy trucks are presented what are the most catastrophic incidents.

#### 4.4.1.6. Turning points

In addition to the cross-passage placed every 1500m along the tunnel. Special turning points are provided in the special cross-sections. These arrangements have to be complemented with intelligent traffic lights placed at adequate distances which have the capacity of allow the turning maneuver without cause much interruption to the traffic. It is recommendable utilized the least possible due can occur some traffic jams or accident if the operations are not correctly supervised.

#### 4.4.1.7. Shelters

The tunnel is not provided by shelters as it function does as well as it constant location. The lateral walls have the function of protection in case of fire or other accident, thus are mechanically ventilated. But in addition there are provide first aid modules at the special cross-sections. This modules can worked as security niche in case of accidents and users can wait there until the situation is controlled by emergency staff. There are provide with a telephone to contact the control centre of the tunnel and also loudspeakers are installed to receive orders from the command center. The details of these first aid modules can be consulted in Figure 4.45.

#### 4.4.1.8. Emergency services

There are provided a total of four emergency service stations along the SFT. The stations are located every 35 km alternating the side of the lane. This distance would allow the intervention of the service in least of 10 minutes at any point of the SFT. The stations are located in a reserved space of the parking area of the special cross-sections. The locations of the emergency services are in the CS-SD at the km: 30, 54, 78 and 102 referenced to the total length of the crossing.

#### 4.4.1.9. Drainage system

The drainage design is one of the most important issues for the design of tunnels. Firstly is important to limit the type of liquids to be drainage. In the case of the proposed SFT in the present work, is forbidden the transit of vehicles with dangerous goods due the catastrophic consequence that could generate an accident which involucres this typology of truck. So, in this case the liquid to be drainage is just the generated inside of the tunnel in case of fire or other accident. Thus for drainage this liquid is necessary provide gradients in the longitudinal axis as well as the transversal. Thereby, the minimum transverse gradient of 2% and the maximum longitudinal gradient shall not exceed of 5%. In addition for accidental cases the volume capability of the sumps must be approximately 100m<sup>3</sup> (72 m<sup>3</sup> for fire extinction and approximately 30 m<sup>3</sup> spill from a tank).

Due the great length of the tunnel, the drainage of the liquid will be realized from the centre of the crossing to the ends. Thus, the highest point of the road surface will be placed at the centre of the SFT. From this point will be decrease the road level through the shores. The longitudinal gradient will be of maximum 2%. All the catch liquid by sumps is drained towards the special elements placed every 6km. In these elements there are tanks where are the liquid is captured. Then when the tank reach the limit a bomb elevate the liquid to reach the level of the next 6-km segment of the tunnel where by gravity the liquid arrive to the tank of the following tank of the special element. Thus, this operation is repeated along the whole tunnel until the liquid of the SFT is drained completely. In Figure 4.46 is shown the distribution of the drainage system in the special element.

#### 4.4.2 Safety equipment

##### 4.4.2.1. Ventilation

Mechanical ventilation is required in the SFT of the Gulf of California. This proposal can be considered as two unidirectional tunnels. Therefore, longitudinal ventilation can be employed since the jet fans and the vehicle piston effect could expulse the smog and others gases outside the tunnel. However, the longitudinal ventilation is not enough due to the great length of the SFT. Therefore is required some extraction points along the tunnel where the polluted air is treated and recycle. In addition fresh air would be supplied uniformly over the length of the tunnel causing the foul air to escape longitudinally from the tunnel. So the ventilation system can be considered as semi-transverse.

Moreover, is required to measure the opacity along the tunnel in distances of maximum 300 m. Closure of the tunnel is necessary, when the CO<sub>2</sub> exceeds a concentration of 200 ppm or an extinction coefficient of 12E-3 m<sup>-1</sup> is exceeded.

The longitudinal ventilation consist in rows of four jet fans mounted on the ceiling every 100m. The jet fans work in conjunction with the vehicle piston effect will produce to move the smog longitudinally. On the other hand the fresh air will be supply along the whole tunnel through the gap upper to the emergency pedestrian passage at each side of the tunnel cross-section. The fresh air will be supplied by air vents placed in every especial element as well as the middle distance between two special elements. It means that they would be located every 3 km. Thus due the great length of the SFT, every special element (6km), it must be placed a fan inside the assigned gap in order to allow impulse the fresh air along the whole tunnel. This will also contribute to have adequate fresh air in the emergency passage once some air vents are placed along this corridor.

Moreover, every special element (6km) is equipped with exhaust fans where the polluted air is extracted and passes throughout a filter for then reinjected to the tunnel as treated air (This system can be appreciate in Figure 4.48).

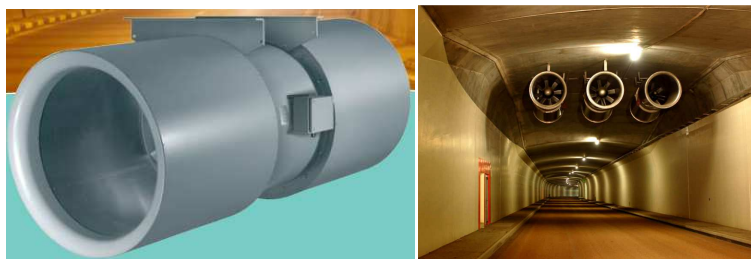

Figure 4.48 SFT ventilation system of the Gulf of California (systemair)

The characteristics of the jet fans are:

- Brand: Systemair
- Size: 500 mm
- Max thrust: 235 N
- Max Motor Power: 6.5 kW
- Motor Speed: 2880 rpm
- Max Velocity: 31.1 m/s

#### 4.4.2.2. Lighting

The luminaries along the SFT are based on LED<sup>8</sup> technology. This new application in tunnel lighting has many advantages against conventional luminaries. It is slightly more efficient, has probably longer life, is more useful for dimming, and the quality of the light seems to be equal or better.

The normal lighting of the tunnel consist in longitudinal light bands on both sides. The luminaries are located at 5 m in the higher part of the walls. In case of emergency, every fourth light will continue operating for about 1 hour following a power breakdown. In Figure 4.49 is shown in luminaries proposed for the SFT.

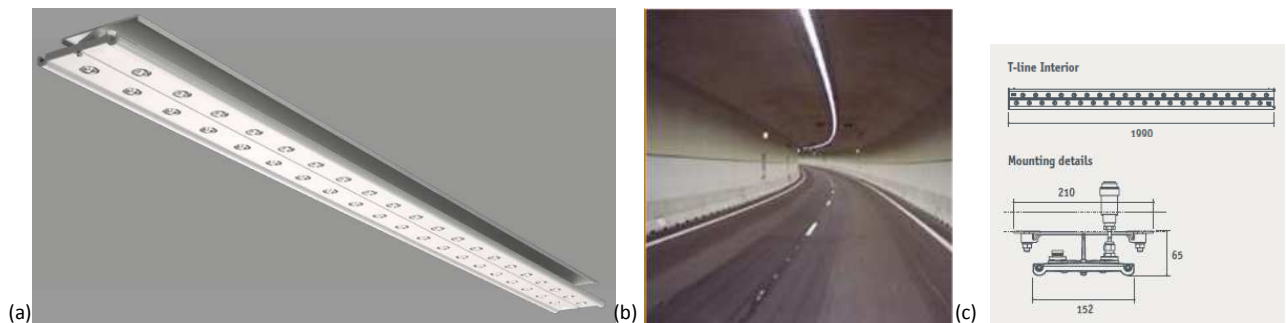

Figure 4.49 Lighting in the SFT of the Gulf of California: (a) Luminary type; (b) Application in one longitudinal band at the ceiling of the tunnel; (c) geometry details (i-tunnelL)

The main characteristics of the luminaries are:

- Name/Code: T-line interior
- Brand: i-Tunnel/Philips WRTL
- Type: 40 LED
- System Power: 50 W
- LED current: 350 mA
- Flux: 4416 Lm
- Weight: 9 kg

The advantage of this type of luminaries are the reduction of energy costs, reduction of CO<sub>2</sub> emissions, increased the lighting uniformity and provides significantly better colour recognition.

#### 4.4.2.3. Signage

At each tunnel entry there would be an information sign with following information:

---

<sup>8</sup> Light Emitting Diode

- Tunnel name
- Height limit and length of the tunnel
- Dangerous Good Vehicles forbidden
- Prohibited access for pedestrians and cyclists
- Radio station of the tunnel control centre
- Variable message sign (principally for knowing the tunnel status)

On the other hand, inside the tunnel the signal would be mainly for informing the status of each lane. It must be placed an open lane or closed lane each 500 m. In addition variable message sign must be placed every 1000 m at each lane.

In addition emergency facilities must be signalized with such as: SOS telephones, extinguishers, emergency exits and the distance to the nearest emergency exit (every 25m).

#### 4.4.2.4. Water supply

The water supply is one of the most important media for firefighting. In SFT the fire fighting system is by means of hydrants. These devices shall be located every 150 m and must have a capacity of 1200 l/min at 6-10 bars. The capacity of the hydrant must be keep during of 1 hour as minimum. On the other hand, water sprinkler systems are not considered for this proposal due they may cool buoyant smoke causing immediate smoke logging of the tunnel and producing potentially explosive air/vapour mixes.

The hydrant consists in a twin valve placed at the lateral walls of the cross section. The valve is made of bronze with chrome finished. It has two inputs of 64mm and one output of 101 mm of diameter. It has two caps with chains and a plate with the legend of "bomberos" (Fire Fighter in spanish). The Figure 4.50 shows the hydrant of the SFT.



*Figure 4.50 SFT Fire Fighting system of the Gulf of California (cogarsa)*

#### 4.4.2.5. Alarm system

Every 100 meters would be located an emergency station. This station is provide with an emergency telephone, one alarm push button (manual fire alarm), and two portable extinguishers of 6kg. The telephone has directly communication with the control centre. In addition the extinguishers have especial sensors which give the signal to the command centre. The same cases are for the emergency doors. Once the signal is detected by the automatic alarm on these equipments the control centre can send the signal to the emergency staff for executing the rescue procedures.

#### 4.4.2.6. Communication

Inside the SFT is provided a FM station where the drivers can receive advises about the tunnel status. Motorist can be inform if there is an accident inside the tunnel, traffic jam, a closed lane or other information useful for the safety of the users. At the entry of the tunnel must be placed a sign where is shown the station number. In combination with the FM station the variable message signs must inform about the tunnel status.

In addition would be available an APP for smart phones. The application would inform via internet the status of the whole tunnel. The application must be downloaded before entry the tunnel so then the message can be received directly to the mobile phones.

#### 4.4.2.7. Traffic regulation - monitoring equipment

In the SFT will be installed an Automatic Incident Detection System (AIDS). For this system is necessary to install CCTV cameras every 60 m. The cameras shall permit recording and supervise during 24 hours. The AIDS system must allow monitoring the number of vehicles, speed, traffic jams, accidents, fires. In case of any incident the control centre must have the capability of send rescue staff to the location where it occurred.

The road carriage of the SFT includes an emergency lane thus install internal stop traffic barriers would be not feasible considering the height of the cross-section. Thereby, in case of accident the closure of lanes will be through the traffic signage of each lane as well as the variable message lanes. Moreover, the traffic barriers will be placed at each tunnel entry, as well as the crossing beginnings (before the bridge).

On the other hand, at each tunnel entry, Termographic Inspection Stations will be placed. In these stations the heat machine of every heavy truck will be inspected. In case of overhead truck will be stop to crossing the SFT for a moment. In these cases in addition a machine evaluation will be carried on in order to know if it has the capacity of crossing the whole SFT without problem. Trucks without the crossing capacity would be asked for leaving the tunnel.

#### 4.4.2.8. Power supply

The normal power supply will be enough for keep all the normal operating of the tunnel without interruptions. The power supply will be by cables and conducts placed in the upper lateral gap of the cross-section. Every especial element will be located a power transformer with the enough capacity to maintain constant power along the tunnel.

In case of emergency an unbreakable system will start working which an interruption guaranteed of 0.0 s. The emergency system shall be sufficient for supply:

- Signage for emergency escape
- Emergency lighting in case of fire
- Emergency lights (approximately of the 10% of the normal lighting)
- Escape route lighting
- Illumination of operational rooms, minimum one lamp per room
- Traffic control systems in the tunnel and at the approaches as far as it is necessary
- Fire alarm systems
- Control systems
- Monitoring systems



#### 4.4.2.9. Mental stress

The great length of the SFT of the Gulf of California represents a really challenge for the engineering. Driving in a tunnel for more than 1 hour becomes the journey stressing. Thus additional improvements must be taking for breaking the monotony of the roadway.

In the longest road tunnels around special considerations were taken (see section 2.2). Increase the cross-section, establishment of big caverns in the tunnel with different lighting colors, recreation of landscapes are some of the implementations took.

For the SFT of the Gulf of California some of these considerations have been adopted since the cross-section design. As it was studied before, there is an enlargement of the cross-section every 6 km, where drivers can stop and rest for few minutes for then continue with their journey. As it can be consulted in section 4.4.1 the special modules are provide with toilets and first aid modules. In addition some of these special elements are equipped with emergency service. Furthermore, in the towers apart from their evacuation function, it can be visited their restaurants and viewpoints for appreciate the marine landscape. All this structural arrangements have the task of break the monotony of drivers.

On the other hand, some visual designs have been considered along the tunnel. The lighting will have different design along the tunnel. The colors will change through the tunnel. In the special modules blue and yellow lighting might simulate the sky in the tunnel. In addition in some parts the walls will have special panels that recreate moving images of dolphins follow the car directions as well as other types of sea life. In some others parts the ceiling will be illuminated with LEDs with the purpose of simulate stars. The lighting in some others will simulate that is being drive in short tunnels against of a one with great length. Furthermore, the special elements would be design as landscape of different regions in the world such as: forest, jungle, desert, arctic, marine, and so on. Some of these visual solutions have been employed in different tunnels as is shown in the Figure 4.51.



Figure 4.51 Visual designs in road tunnel: (a) Fehmarnbelt Tunnel, Denmark-Germany; (b) Dongshan Tunnel, China; (c) Södra Länken Tunnel and Stockholm bypass, Sweden; (d) Qinling Zhongnan tunnel, China

**4.5 Sketches**

The following drawings of the Submerged Floating Tunnel proposed in the work are shown in order to giving a more clear idea of the project. There is shown the configuration arrangement including the different cross-section designed and the anchorage system employed. In Figure 4.52 can be appreciated the standard cross-section in a 3D rendering from different perspectives.

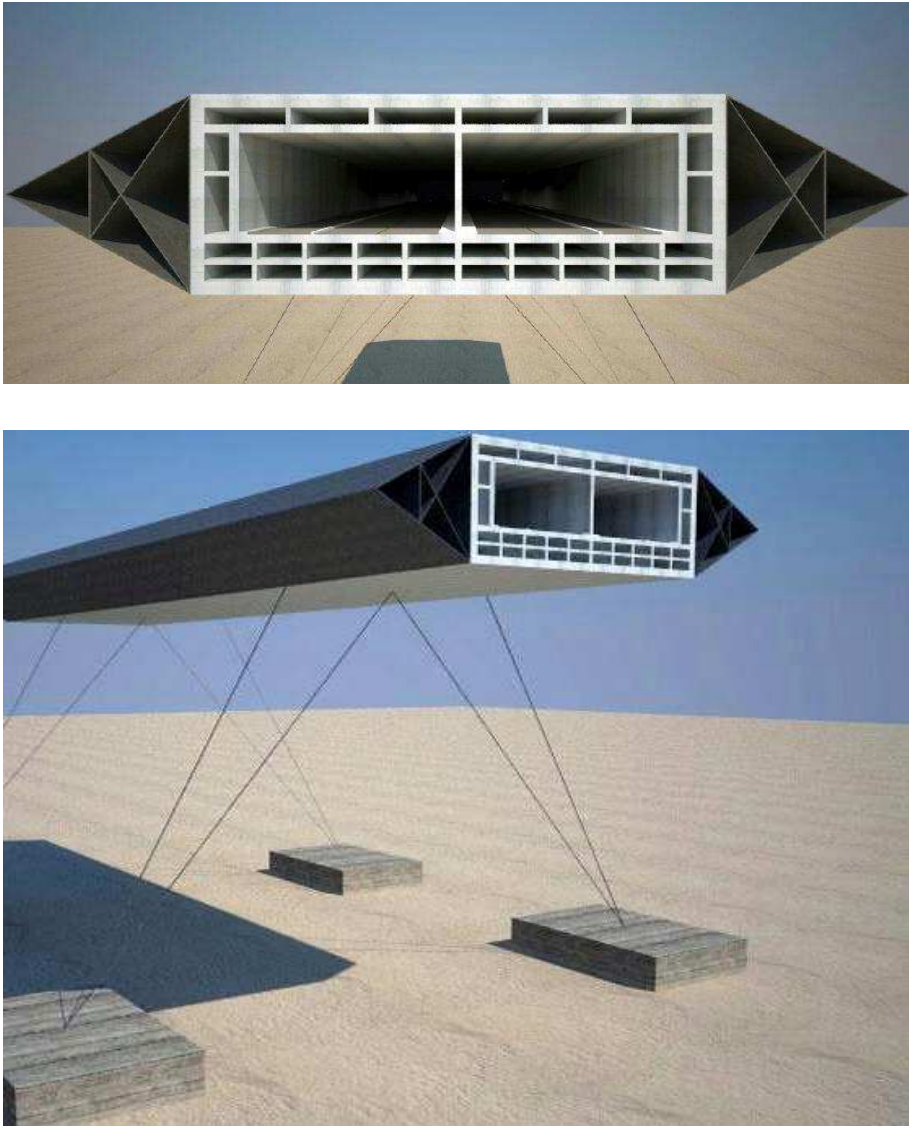

*Figure 4.52 3D rendering of the standard cross-section*

In Figure 4.53 is shown the sketches of the special cross-section with the anchorage system adopted.

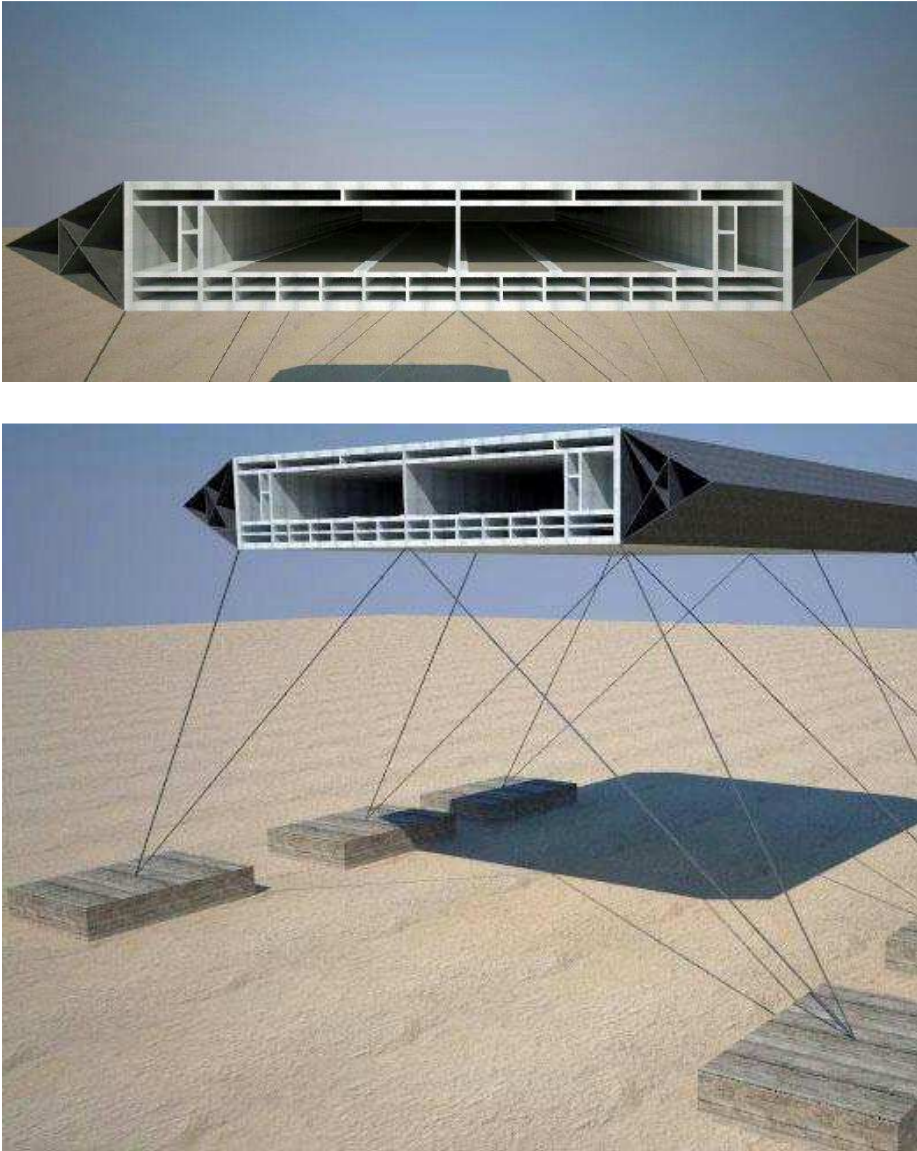
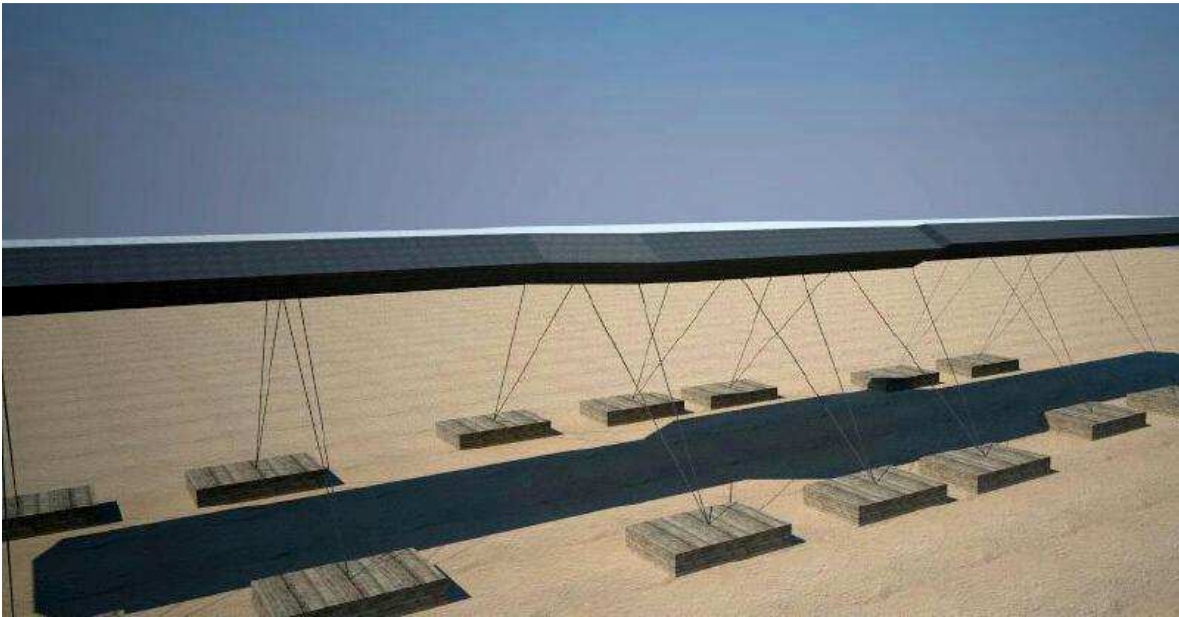

Figure 4.53 3D rendering of the special cross-section

In addition in Figure 4.54 is presented the joint of the different cross-section in the tunnel from a longitudinal view





*Figure 4.54 3D rendering of the longitudinal alignment of the SFT of the Gulf of California*

## Conclusions

The amazing field of the Submerged Floating Tunnels is studied in this thesis project. The huge area of SFT technology is explained including its advantages against conventional waterway crossings. Furthermore the different proposals around the world are presented, since this solution began until nowadays. In addition, the work touched all the possible configurations of the newest SFT proposals in the world which became more efficient once that are combined with others conventional waterway crossings.

Moreover, the great length of the proposal in this work lead to carried out a huge research about the tunnel technology. The investigation was focus on the longest tunnels in the world as well as the most modern tunnel projects. Especially attention was taken in the safety taken in the diverse road tunnels including, mountain tunnels, subsea tunnels and mainly in immersed tunnels. The study of the different codes and regulation for the countries with more experience in tunnels was one of the most important issues of this work in order to applying the safety requirements in the SFT proposed in this work. The studied of the precast tunnels was another object of study, mainly the fabrication and erection process due the similarity with SFT.

As the objective of the thesis project was to propose a SFT for crossing the Gulf of California, it was necessary to find the suitable location for the waterway crossing. So, the study natural conditions of the Gulf of California were required for establishing the site of the SFT. Thus the collection of data from different institutions was carried on. Once it was studied the sea state of the Gulf of California could be compared to others natural conditions of different SFT locations in the world.

In order to goal the proposed of the thesis, the application of the acquired knowledge from all the chapter of the work was necessary. In general it was proposed a SFT which consider different solutions of other worldwide proposals. In addition, the most modern solutions from the different regulations in the world were adopted in order to assure the safety along the great length of the SFT. Additionally, it was implemented different solutions for long road tunnels in current projects as well as futures ones.

In conclusion, in the point of view of the writer, the SFT proposed in the present work can be considered as one of the safest solutions for long road tunnels due are considered the most modern innovations of safety in tunnels. Thereby, the most remarkable solution in the SFT proposed can be listed here below:

- The SFT location in the Gulf of California guarantees the good behavior since the structural point of view once the selected site meets all the established criteria at the beginning of the work.
- The cross-section design provides protection of the SFT structure either for internal impacts as external collisions.
- The double-wall system employed in the cross-section of the SFT avoids any catastrophic failure caused by flooding of the structure.
- The segmental construction method for the elements allows fabricating longer elements what it impact directly in the cost and schedule of the project, once are less elements to be subjected to the submerged process.
- If segmental construction method is used it would not be necessary cooling the concrete due there is a better control of the concrete placing what leads to faster production process.

- Placing the lowest point of the drainage system at the ends of the tunnel allows draining the liquids of the tunnel using the gravity force in conjunction with few pumps, what would result in a more efficient system.
- The design of the drainage allows to the SFT withstand even in presence of leaking from the exterior.
- The standardized foundation blocks allow more efficient fabrication process due it would use the same production line for all the cases.
- The normalized cable diameter of the anchorage system leads to standardize the cable-structure connection devices what become a more efficient erection process.
- The access structure is a really efficient solution to descend great elevations in short distance.
- The access structure allows reducing the length of the SFT due to a bridge can be linking at the top of the structure.
- The towers represent an innovate solution for the SFT what provides shorter evacuation points. The evacuation media is through the heliport located on the roof floor of the platform.
- The towers also are approached as touristic centre where drivers can relax and break the monotony of the long journey.
- The mental stress of the drivers is considered in the interior design of the tunnel.
- The drivers are keep awake by enlarge the cross-section, change of the lighting along the tunnel, segments with moving images at the walls and different landscape on the tunnel.
- The structural measures and the equipment employed ensure the safety of the drivers along the whole tunnel, either for self-rescue service as well as rescue media for the emergency staff.
- In case of emergency the design of the tunnel allows to the users be on safe at less than 5 minutes walking
- The location of the emergency service on the tunnel would have a time response of maximum 10 minutes.

In general the Submerged Floating Tunnel proposed in the present work takes the most modern solutions for tunnels including immersed tunnels and others SFT. Nowadays the evolution of tunnel project is a reality. These roadways went from being those long dark crossing which used to transmit insecurity to the drivers for now become in really aesthetic roads. Thereby, all this improvements in tunnel technology must be adopted for SFT, mainly when the crossing proposed represents a long journey. A fact is that SFTs have a tunnel configuration at their interior, while the external part of these crossing solutions is why represents a really advantageous solution against conventional waterway crossings. Thus, for Submerged Floating Tunnels the following recommendations can be concluded:

- Submerged Floating Tunnels are a suitable solution for wide and deep water crossings.
- The configuration of the SFT depends mainly of the environmental conditions at the site. In severe natural conditions is most recommendable a SFT anchored at the seabed, while in calm conditions a SFT supported by pontoons on the surface would be ideal.
- The cross-section of the SFT shall guarantee the safety of the users as well as minimize the hydrodynamic forces.
- The SFT positions must guarantee the shipping traffic.
- In case of utilize pontoon on the surface the gaps between them must provide a navigation channel.

- The pontoons must be design against shipping impacts and also the SFT must withstand in case of the flooding of one pontoon.
- In case of utilize anchorage system, it must provide lateral stiffness along the elements. The lateral displacements are the most critical issue of caring.
- The cables must be designed with the maximum residual buoyancy, it means when no live loads are on the elements.
- The foundation system must resist the forces generated by the maximum residual buoyancy of the SFT.
- The joints shall guarantee waterproofing to the SFT and the ease in the erection of the structure. Rigid joints are recommendable.
- In long SFTs the longitudinal displacements shall be absorbed by joints placed at certain distance along the tunnel as well as the end connections.
- The shore connections must be design in order to absorb the seismic events. It shall allow vertical, horizontal and rotation displacement.
- The type of access structure to the SFT depends of the topography at the shores and a suitable analysis must be executed.
- The employ of towers for evacuation media represents a great solution for really long SFTs.
- The combination of SFT with bridges or other crossing solutions in some case is more advantageous than employed just SFT. The bridge can reduce the length of the tunnel.

A fact is that Submerged Floating Tunnels represents a really advantageous solution for wide and deep waterway crossing. Thus, many SFTs have been proposed around the world where no other conventional structure could be realized. However, none Submerged Floating Tunnel have been constructed yet.

Lots of investigations in SFT field have been carried on in different countries by many institutions and researchers. Despite of the many experimental studies about the behavior of the SFT, it has not verified the results in a real test. Therefore, there is still uncertainty about the behavior of the structure under real conditions.

Hence, in the point of view of the writer, for landing the Submerged Floating Tunnel as a real crossing solution, firstly must be constructed a prototype where it can be evaluated the behavior of the structure. So then could realize some adjust or improvements until reach the reliability of the structure. After executed this step, many Submerged Floating Tunnels will begin to seeing in the world.

#### ➤ Recommendations

The Submerged Floating Tunnel is an emerging technology with many areas to be investigated. Many studies, mainly since the 80s have been carried on. The developments of modern softwares have resulted in more accuracy results. The numerical experiments that can be found in the current literature are focus mainly on the behavior of the structure under hydrodynamic actions as well as seismic events. Furthermore, some studies consider external impacts of some accidental scenarios. Additionally, few works are approached on constructional process.

Nowadays, there are feasibility studies of SFT proposals mainly in European and Asian countries. A similar solution is presented in the present work where a SFT is presented as solution to crossing the Gulf of California in Mexico. As it was studied, the work consists in the conceptual design of the SFT. It touched the different issues which involve a SFT. In addition, are studied the environmental conditions of the Gulf of California. Despite the designs executed in this work, many others studies are recommended in order to deepen the solution studied. The writer recommends the following researches that could complement the present work:

- The structural analysis of the Submerged Floating Tunnel of the Gulf of California with the designs executed in the present work.
- The feasibility study of the SFT of the Gulf of California.
- The planning of the project, including the suitable construction method of all the different issues.
- The budget of the project.
- The impact of the SFT in the region. Considering the economical analysis, social analysis and financial analysis.
- The study of other configurations of anchorage system in order to placed the SFT in the southern part of the Gulf of California.
- A simulation test for driving in the long journey in order to prove the mental stress solutions.



## References

Aas-Jakobsen K., Jakobsen S.E., Karlsrud K., Fredriksen F. (2013). "Deep sea foundations for strait crossings", Proceedings of the 6<sup>th</sup> Strait Crossing Symposium, P.p. 584-592. Bergen, Norway.

Ahrens D. (1997). "Submerged Floating Tunnels – a concept whose time has arrived", Tunneling and Underground Space Technology, Volume 12, pp.317-336.

American Petroleum Institute (2002). "API RP2A-WSD-Recommended Practice for Planning, Designing and Constructing Fixed Offshore Platforms—Working Stress Design".

Asociacion Portuaria Integral de Baja California Sur (APIBCS), general information of the port of the mexican state of Baja California Sur. Information available at the website: [www.apibcs.com](http://www.apibcs.com)

Atmospheric Centre of Science of National Autonomous University of Mexico (2013). Digital climate atlas of the Mexican republic. Available at the website: [www.uniatmos.atmosfera.unam.mx/ACDM/](http://www.uniatmos.atmosfera.unam.mx/ACDM/)

Center for Scientific Research and Higher Education of Ensenada (CICESE), (2013). Information of the Oceanographic Stations on the Mexican coasts. Available at the website: [www.cicese.edu.mx](http://www.cicese.edu.mx)

Comision Federal de Electricidad (CFE), (2003), "Design Manual for Seism", Design Manual of Civil Works, Chapter 3, Mexico. (In Spanish)

Comision Federal de Electricidad (CFE), (2008), "Design Manual for Seism", Design Manual of Civil Works, Chapter 3, Mexico. (In Spanish)

Comision Federal de Electricidad (CFE), (2008), "Design Manual for Wind", Design Manual of Civil Works, Chapter 4, Mexico. (In Spanish)

Comision Nacional de Areas Protegidas (CONANP), Map of the Natural Protected Areas of Mexico.

Comisión Nacional para el Conocimiento y Uso de la Biodiversidad (CONABIO), Information of the water temperature in the Gulf of California by the Monitoring Satellite System (SATMO), Mexico.

COWI Company (2009). "Busan - Geoje Immersed Tunnel, Korea", Technical Sheet available at the website [www.cowi.com](http://www.cowi.com).

Dahl K.O. (2013). "Combined Floating Bridges and Submerged Tunnel", Proceedings of the 6<sup>th</sup> Strait Crossing Symposium, P.p. 813-824. Bergen, Norway

De Wit, J.C.W.M., Van Putten, E. (2012). "Immersed Tunnels: Competitive tunnel technique for long (sea) crossings", Under City 2012 Dubrovnik, Croatia.

Directive 2004/54/EC of the European Parliament and of the Council, (2004), "Minimum safety requirements for tunnels in the Trans-European Road Network",. Official Journal of the European Union.

Eidsheim O.M. et al., (2013). "Crossing of wide fjords by double walled Submerged Floating Tunnel (SFT)", Proceedings of the 6<sup>th</sup> Strait Crossing Symposium, P.p. 498-507. Bergen, Norway.

Espedal T.G. (2013). "The Rogfast Tunnel", Proceedings of the 6<sup>th</sup> Strait Crossing Symposium, P.p. 309-317. Bergen, Norway.

(ETNFT) European Thematic Network Fire in Tunnels, "Fire Safe Design – Road Tunnels", Technical Report part 2.

Faggiano B., Landolfo R., Mazzolani F.M. (2001a). "Analysis Project concerning a "Ponte di Archimede" in the Jintang Strait", Final Report of the Italian-Chinese cooperation project.

Faggiano B., Landolfo R., Mazzolani F.M. (2005). "The SFT: an innovative solution for waterway strait crossings". Proceedings of the IABSE Symposium "Structures and Extreme Events", Lisbon, Portugal, September 14-17.

Fjeld A., et al., (2013). "Development of a Submerged Floating Tunnel concept for crossing the Sognefjord", Proceedings of the 6<sup>th</sup> Strait Crossing Symposium, P.p. 593-602. Bergen, Norway.

Forum of European National Highway Research Laboratories FEHRL (1996). "Analysis of the submerged floating tunnel concept". FEHRL report no. 1996/2a.

Garcia G., Marione S.G. (1997). "Modelling of Residual Currents in the Gulf of California using different grid sizes", Marine Sciences, 23(4) P.p. 505-519. Mexico

Genovese N., Olsen T. (2013), "Planning of complex Immersed Tunnels in wave and currents", Proceedings of the 6<sup>th</sup> Strait Crossing Symposium, P.p. 564-574. Bergen, Norway.

Grantz W. (1997). "Steel-Shell Immersed Tunnels-Forty Years of Experience", Tunneling and Underground Space Technology. Vol.12, No.1, pp.23-31.

Grantz W., Tan L., Sørensen E., Burger H. (1997). "Waterproofing and maintenance", Tunneling and Underground Space Technology. Vol.12, No.2, pp.93-109.

Grantz W. (2003). "A new concept for a steel shell submerged floating tunnel", "(Re)Claiming the Underground Space", Vol. 1, pp. 297 – 302.

Grantz W. (2010). "Conceptual study for a deep water, long span, Submerged Floating Tunnel (SFT) crossing", Procedia Engineering, Volume 4, 2010, Pp. 61-70, ISAB-2010, First International Symposium on Archimedes Bridge (ISAB-2010).

Grantz W. (2013), "The Immersed Bridge Tunnel (IBT)", Proceedings of the 6<sup>th</sup> Strait Crossing Symposium, P.p. 6-14. Bergen, Norway.

Gursoy A. (1995). "Immersed Steel Tube Tunnels:An American Experience", Tunnelling and Underground Space Technology, Vol 10, No. 4, pp. 439—453, 1995.

Hakkaart J.A. et al., (1993). "Submerged Floating Tunnels", Tunneling and Underground Space Technology, Vol. 8, No. 2, pp. 265-285, 1993.

Holst J. (2013). "Planning of modern road tunnels for the future", Proceedings of the 6<sup>th</sup> Strait Crossing Symposium, P.p. 107-120. Bergen, Norway.

Jakobsen B., Haaland P., Haugerud S.A. (2009). "Crossing the wide and highly exposed Sulafjord with an SFT", Proceedings of the 5th Symposium on Strait Crossings, Trondheim, Norway.

Jakobsen B., Larssen L.R., Egseth G., Karlsrud K., Bjerkeli L. (2013). "Various SFT concepts for crossing wide and deep fjords", Proceedings of the 6<sup>th</sup> Strait Crossing Symposium, P.p. 430-440. Bergen, Norway.

Jimenez A., Marione S.G., Parés-Sierra A. (2005). "Effect of the spatial and temporal variability of winds on the circulation in the Gulf of California", Marine Sciences Vol. 31, N° 2, P.p. 357-368, 2005.

Kanie S. (2010). "Feasibility studies on various SFT in Japan and their technological evaluation", Procedia Engineering, Volume 4, 2010, Pp. 13-20, ISAB-2010, First International Symposium on Archimedes Bridge (ISAB-2010).

Kim Y, Kim J., Lee J. (2009). "Busan-Geoje Fixed Link Immersed Tunnel", Proceedings of the 5th Symposium on Strait Crossings, Trondheim, Norway.

Lavin M.F., Marione S.G. (2003). "An overview of the physical oceanography of the Gulf of California", Department of Physical Oceanographic, CICESE, Kluwer Academic Publishers, Pp. 173-204, Baja California, Mexico.

Makarov V., Jiménez A. (2003). "Barotropic background currents in the Gulf of California", National Polytechnic Institute of Mexico, Marine Sciences, pp. 141-153. Mexico

Marshall C. (1999), "The Oresund Tunnel-Making a Success of Design and Build", Tunneling and Underground Space Technology, Vol. 14, No. 3, pp. 355-365.

Martire G. (2007). "Submerged Floating Tunnel performance evaluation", Master Degree Thesis in Structural and Geotechnical Engineering, University of Naples "Federico II".

Martire G., (2010), "The development of Submerged Floating Tunnels as an innovative solution for waterway crossings", PhD Thesis in Construction Engineering, University of Naples "Federico II", Italy.

Martire G., Faggiano B., Esposto M., Mazzolani F.M., Landolfo R., Zollo A., Stabile T.A. (2009a). "The structural response of Submerged Floating Tunnel to multi-support seismic excitations", Proceedings of the International Conference STESSA09 "Seismic Behaviour of Steel Structures in Seismic Areas", Philadelphia, USA.

Martire G., Esposto M., Faggiano B. & Mazzolani F.M., Zollo A. & Stabile T.A. (2009b). "The seismic response of Submerged Floating Tunnel under multi-support excitations". Proceedings of the XIII National Congress "L'ingegneria sismica in Italia", ANIDIS, Bologna, Italy.

Mazzolani F.M., Landolfo R., Faggiano B., Esposto M., Martire G., Perotti F., Di Pilato M., Barbella G., Fiorentino A. (2007). "The Archimede's Bridge Prototype in Qiandao Lake (PR of China). Design Report". Contribution of the Italian Team. "Sino-Italian Joint Laboratory of Archimedes Bridge" (SIJLAB), Research project report.

Mazzolani F.M., Landolfo R., Faggiano B., Esposto M., Perotti F., Barbella G. (2008). "Structural analyses of the Submerged Floating Tunnel prototype in Qiandao Lake (PR of China)", International Journal Advances in Structural Engineering.

Mazzolani F. M., Faggiano B., Martire G. (2010). "Design aspects of the AB prototype in the Qiandao Lake", Procedia Engineering, Volume 4, 2010, Pp. 21-33, ISAB-2010, First International Symposium on Archimedes Bridge (ISAB-2010).

Monster R. (2013). "TLP technology: the tether system", Proceedings of the 6<sup>th</sup> Strait Crossing Symposium, P.p. 930-941. Bergen, Norway.

Navy of Mexico (2010). "Nautical Chart from the Northern Gulf of California- SM200", General Direction of Oceanography, Hydrography and Meteorology. Mexico

Navy of Mexico (2010). "Nautical Chart from the Southern Gulf of California- SM300", General Direction Oceanography, Hydrography and Meteorology, Mexico

Norwegian Public Roads Administration (NPRA), (2004). "Handbook N°22: Road Tunnels", Norwegian Public Roads Administration Handbooks. Norway.

Øvstedal E., Henning J.E. (2013). "Thirty years of experience with subsea road tunnels in Norway", Proceedings of the 6<sup>th</sup> Strait Crossing Symposium, P.p. 340-363. Bergen, Norway.

Opgård B. (2013). "Submerged Floating Tunnel in Steel for Sognefjorden", Proceedings of the 6<sup>th</sup> Strait Crossing Symposium, P.p. 71-80. Bergen, Norway.

Pedersen S., Hemel A., Lykke S., (2013). "The Fehmarnbelt Tunnel Crossing: the World Largest IMT", Proceedings of the 6<sup>th</sup> Strait Crossing Symposium, P.p. 196-205, Bergen, Norway.

Petroleos Mexicanos (PEMEX), (2008). "Norm NRF-003-PEMEX-2007: Design and Evaluation of Fixed Marine Platform in the Gulf of Mexico", Technical Subcommittee for the exploration and production of PEMEX, Mexico.

Portillo P. (2012). "Structure and kinematics of the Opening of the Gulf of California trough Physical Experiments of Crustal and Lithospheric Extension", Master thesis on Earth Sciences, National Autonomous University of Mexico, Mexico.

Quanke S. et al., (2010). "Hongkong Zhuhai Macao Bridge Link in China Stretching the limits of Immersed Tunnelling". China.

Rengui W., Fanchao M. "Hangzhou Bay Bridge – a 36 km shortcut between Shanghai and Ningbo". China

Rivillas G. (2008). "Wave re-analysis for Mexico: 1948-2007", Master Thesis on Civil Engineering-Hydraulic, Institute of Engineering, National Autonomous University of Mexico, Mexico

Rosas A. "Geostrophic Currents in the Gulf of California on the surface and at 200m depth, during the seasons of winter and summer", National Institute of Fishing, Mexico.

Sato M., Kanie S., Kasajima M. (2013). "The past, present and future of the Seikan Tunnel", Proceedings of the 6<sup>th</sup> Strait Crossing Symposium, P.p. 836-841. Bergen, Norway.

Secretaría de Comunicaciones y Transportes (SCT), (1991). "Geometric Project Manual of Roadways", Mexico. (In Spanish)

Secretaría de Comunicaciones y Transportes (SCT), (2005). "Norma N-PRY-CAR-10-01-002/05: Project of Signage and Safety Devices in Streets and Roadways", Project/Roadways. Mexico

Secretaría de Comunicaciones y Transportes (SCT), Dirección General de Puertos, Information of the draft in the ports of Mexico. Information available at the website: [www.sct.gob.mx](http://www.sct.gob.mx)

Secretaria de Gobernacion (SEGOB), (2011). "Norm NOM-003-SEGOB-2011: Signage of civil protection, colors, shapes and symbols to use", Official Journal of the Federation, Mexico. (In Spanish)

Secretaria del Medio Ambiente y Recursos Naturales (SEMARNAT), "General Description of the Gulf of California", Marine-Ecological Ordering of the Gulf of California. (In Spanish)

Skorpa L. (2010). "Developing new methods to cross wide and deep Norwegian fjords", Procedia Engineering, Volume 4, 2010, Pp. 81-89, ISAB-2010, First International Symposium on Archimedes Bridge (ISAB-2010).

Seo S., Sagong M., Son S.W. (2013). "Global response of Submerged Floating Tunnel against underwater explosion", Proceedings of the 6<sup>th</sup> Strait Crossing Symposium, P.p. 825-835, Bergen, Norway.

Trelleborg Bakker B.V. (2008). "Commercial brochure on Gina gasket", available at <http://www.trelleborg.com.au/Documents/TrelleborgGina.pdf>

Velazco O.U., Marione S.G. (1999). "A numerical study of the Lagrangian circulation in the Gulf of California", Elsevier Science, Journal of Marine Systems 22, P.p. 1-12.

Wanvik P.O. (2013). "Tunnel Lighting", Proceedings of the 6<sup>th</sup> Strait Crossing Symposium, P.p. 669-676, Bergen, Norway.

World Road Association (PIARC), (2001), "Report on Communication Systems and Geometry", Committee on Road Tunnels (C5).

World Road Association (PIARC), (2011), "Manual on Road Tunnels - Cap.1, Strategic issues", XXIV World Road Congress, September, Mexico.

World Road Association (PIARC), (2011), "Manual on Road Tunnels - Cap.2, Safety", XXIV World Road Congress, September, Mexico.

World Road Association (PIARC), (2011), "Manual on Road Tunnels - Cap. 6, Geometry", XXIV World Road Congress, September, Mexico.

World Road Association (PIARC), (2011), "Manual on Road Tunnels - Cap.7, Structural Facilities", XXIV World Road Congress, September, Mexico.

World Road Association (PIARC), (2011), "Manual on Road Tunnels - Cap. 8, Equipment and systems", XXIV World Road Congress, September, Mexico.

Zhang K. et al., (2010), "Research on tubular segment design of submerged floating tunnel", Procedia Engineering, Volume 4, 2010, Pp. 199-205, ISAB-2010, First International Symposium on Archimedes Bridge (ISAB-2010).