

IX CURSO INTERNACIONAL DE CONTAMINACION DE ACUIFEROS

MODULO 3.- MODELOS MATEMATICOS EN GEOHIDROLOGIA
Y CONTAMINACION DE ACUIFEROS

6 AL 10 DE OCTUBRE DE 1997

DIA	HORA	TEMA	PROFESOR
LUNES 6	9:00 A 12:00	MODELOS DE FLUJO	ING. MANUEL MTZ. MORALES
	12:00 A 14:00	CALCULO DE TALUDES EN RELLENOS SANITARIOS	ING. FEDERICO MEIXUEIRO
	16:00 A 19:00	HERRAMIENTAS INFORMATICAS	ING. FEDERICO MEIXUEIRO
MARTES 7	9:00 A 12:00	MODELOS GEOFISICOS EN CONTAMINACION	ING. ALFONSO ALVAREZ M.
	12:00 A 14:00	MODELO DE FLUJO "PLASM"	ING. DAVID GLEZ. POSADAS
	16:00 A 19:00		
MIERCOLES 8	9:00 A 14:00	MODELO DE FLUJO "MODFLOW"	ING. RODRIGO MEDINA
	16:00 A 19:00	MODELO DE FLUJO VMODFLOW	ING. LUIS E. LESSER CARRILLO
JUEVES 9	9:00 A 14:00	MODELOS DE TRANSPORTE	M. EN C. FERNANDO LARA
	16:00 A 19:00		
VIERNES 10	9:00 A 14:00	MODELOS EN GEOHIDROLOGIA	ING. JUAN M. LESSER ILLADES
	16:00 A 19:00	MESA REDONDA	



**FACULTAD DE INGENIERIA U.N.A.M.
DIVISION DE EDUCACION CONTINUA**

CURSOS ABIERTOS

**“ IX CURSO INTERNACIONAL DE CONTAMINACIÓN DE
ACUÍFEROS “**

MODULO III

**MODELOS MATEMÁTICOS
EN GEOHIDROLOGÍA**

TEMA

**CÁLCULO DE TALUDES EN
RELLENOS SANITARIOS**

**EXPOSITOR: ING. FEDERICO MEIXUERIO T.
1997**

IX CURSO INTERNACIONAL DE CONTAMINACIÓN DE ACUÍFEROS.

Coordinador General Académico: Ing. Juan Manuel Lesser I.

Módulo III: Modelos Matemáticos en Geohidrología.

Sección 1ª: Herramientas Informáticas para el Modelado Matemático.

Profesor: Ing. Federico Meixueiro T.

ESTABILIDAD DE TALUDES

- 1.- Introducción.
- 2.- Taludes Artificiales.
- 3.- Tipos de Fallas más comunes en los Taludes.
- 4.- Fallas Ligadas a la Estabilidad de Laderas Naturales.
 - 4.1.- *Deslizamiento superficial asociado a falta de resistencia por baja presión de confinamiento (creep).*
 - 4.2.- *Fallas asociadas a procesos de deformación acumulativa, generalmente relacionadas con perfiles geológicos desfavorables.*
 - 4.3.- *Flujos.*
- 5.- Fallas Relacionadas a la Estabilidad de Taludes Artificiales.
 - 5.1.- *Falla Rotacional.*
 - 5.2.- *Falla Translacional.*
 - 5.3.- *Fallas con Superficie Compuesta y Fallas Múltiples.*
 - 5.4.- *Derrumbes y Caídos.*
 - 5.5.- *Otros tipos de fallas, no directamente asociadas a la resistencia al esfuerzo cortante de los suelos.*
- 6.- Métodos de Cálculo de Estabilidad de Taludes.
 - 6.1.- *Falla Rotacional. Método Sueco.*
 - 6.2.- *Casos Distintos.*
- 7.- Factores que Producen Fallas de Estabilidad de Laderas y Taludes.
- 8.- Ejemplo Práctico.

ESTABILIDAD DE TALUDES

1.- Introducción.

Se conocen con el nombre genérico de taludes, cualesquiera superficies inclinadas respecto a la horizontal que hayan de adoptar permanentemente las masas de tierra. Cuando el talud se produce en forma natural, sin intervención humana, se denomina ladera natural o simplemente ladera.

Cuando los taludes son hechos por el hombre se denominan cortes o taludes artificiales, según sea la génesis de su formación; en el corte, se realiza una excavación en una formación térrea natural, en tanto que los taludes artificiales son los lados inclinados de los terraplenes.

También se producen taludes en los bordes de una excavación que se realice a partir del nivel del terreno natural, a los cuales se les suele denominar taludes de la excavación.

En primer lugar será preciso analizar la necesidad de definir criterios de estabilidad de taludes, entendiéndose por tales algo tan simple como el poder decir en un instante dado cuál será la inclinación apropiada en un corte o terraplén; casi siempre será la más apropiada la más escarpada que se sostenga el tiempo necesario sin caerse. Aquí radica la esencia del problema y la razón de su estudio. A diferentes inclinaciones del talud corresponden diferentes masas de material térreo por mover y, por lo tanto, diferentes costos.

De ésta manera, los taludes son estructuras que en general se deben proyectar y construir con una motivación económica.

2.- Taludes Artificiales.

Dentro de los taludes artificiales también existen diferencias esenciales entre los cortes y los terraplenes. Estos últimos constituyen una estructura que se construye con un material relativamente controlado o que, por lo menos en un principio se puede controlar; en los cortes, no existe ésa posibilidad. Es obvio que tales condiciones de formación han de imponer variantes en la naturaleza de los materiales con que se haya de trabajar, en su homogeneidad y en su disposición, que han de reflejarse fundamentalmente en la estructura final a que se llegue y en todos los aspectos de su comportamiento.

Otro aspecto que genera confusión dentro de la concepción del problema de "estabilidad de taludes" es, el que emana de la extraordinaria complejidad y multiplicidad de lo que ha dado en llamarse "falla del talud". Desde luego no existe un consenso universal en lo que debe entenderse como tal; la gran mayoría de las fallas de taludes se definen en términos de derrumbes o colapsos de toda índole, que no dejan duda en pensar que ha ocurrido algo que pone en serio entredicho la función estructural.

La naturaleza y homogeneidad de los materiales constitutivos son básicos para plantear y definir el problema de la estabilidad de un talud en cualquiera de sus múltiples aspectos.

3.- Tipos de Fallas más comunes en los Taludes.

Se presentan a continuación las fallas más comunes de los taludes. En primer lugar se distinguen las que afectan principalmente a las laderas naturales de las que ocurren sobre todo en los taludes artificiales.

Los factores de que dependen la estabilidad de las masas de tierra se pueden agrupar como se muestra en

la siguiente tabla:

Factores de que depende la estabilidad de los taludes.	
a)	Factores geomorfológicos.
a.1)	Topografía de los alrededores y geometría del talud.
a.2)	Distribución de las discontinuidades y estratificaciones.
b)	Factores internos.
b.1)	Propiedades mecánicas de los suelos constituyentes.
b.2)	Estados de esfuerzos actuantes.
c)	Factores climáticos y concretamente, el agua superficial y subterránea.

4.- Fallas Ligadas a la Estabilidad de Laderas Naturales.

Debido a que éstas fallas no están contempladas de manera directa en la estabilidad de taludes artificiales, que es el tema que nos ocupa, únicamente se proporcionará una breve descripción de ellas.

4.1.- Deslizamiento superficial asociado a falta de resistencia por baja presión de confinamiento (creep).

Se refiere a ésta falla al proceso más o menos continuo y por lo general lento, de deslizamiento ladera abajo que se presenta en la zona superficial de algunas laderas naturales.

El creep suele afectar a grandes áreas y el movimiento superficial se produce sin una transición brusca entre la parte superficial móvil y las masas inmóviles más profundas. No se puede hablar de una superficie de deslizamiento. El creep suele deberse a una combinación de las acciones de las fuerzas de gravedad y de otros varios agentes. La velocidad de movimiento ladera abajo de un creep típico puede ser muy baja y rara vez excede de algunos centímetros por año.

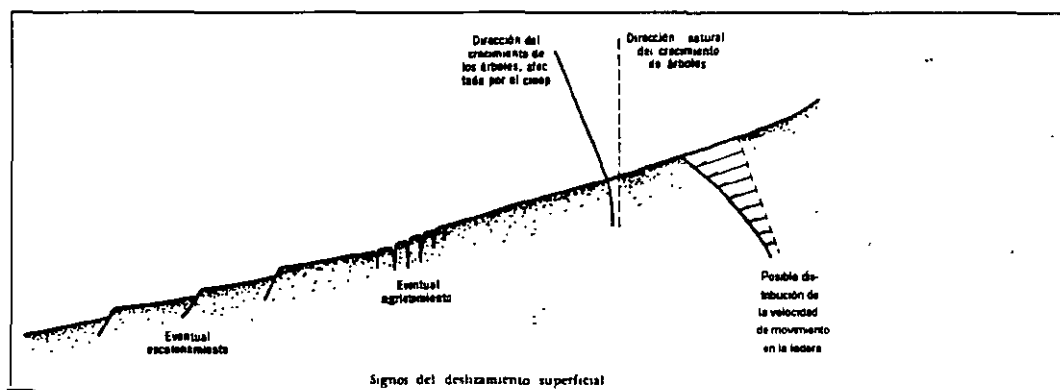

4.2.- Fallas asociadas a procesos de deformación acumulativa, generalmente relacionadas con perfiles geológicos desfavorables.

Se refiere éste título al tipo de fallas que se producen en las laderas naturales como consecuencia de procesos de deformación acumulativa, por la tendencia de grandes masas a moverse ladera abajo. Este tipo de fallas quizá es típico de laderas naturales en depósitos de talud o en otras formaciones análogas en cuanto a génesis geológica, formadas por materiales bastante homogéneos, no consolidados y bajo la acción casi exclusiva de las fuerzas gravitacionales. Muchas veces aparecen en el contacto de éstos depósitos con otros subyacentes, más firmes.

En tales condiciones, ha de pensarse que la ladera se formó con una inclinación que no puede exceder mucho la del equilibrio crítico y por ello es lógico pensar que en el interior de la masa existan fuertes tendencias al deslizamiento, que se traducirán en deformaciones importantes de los suelos afectados.

Dado el largo tiempo en que tales esfuerzos gravitacionales actúan en los materiales del interior de la ladera, la resistencia al esfuerzo cortante podrá degradarse por procesos de deformación acumulativa y en ciertas zonas dentro de la ladera se desarrollan estados de creep profundo.

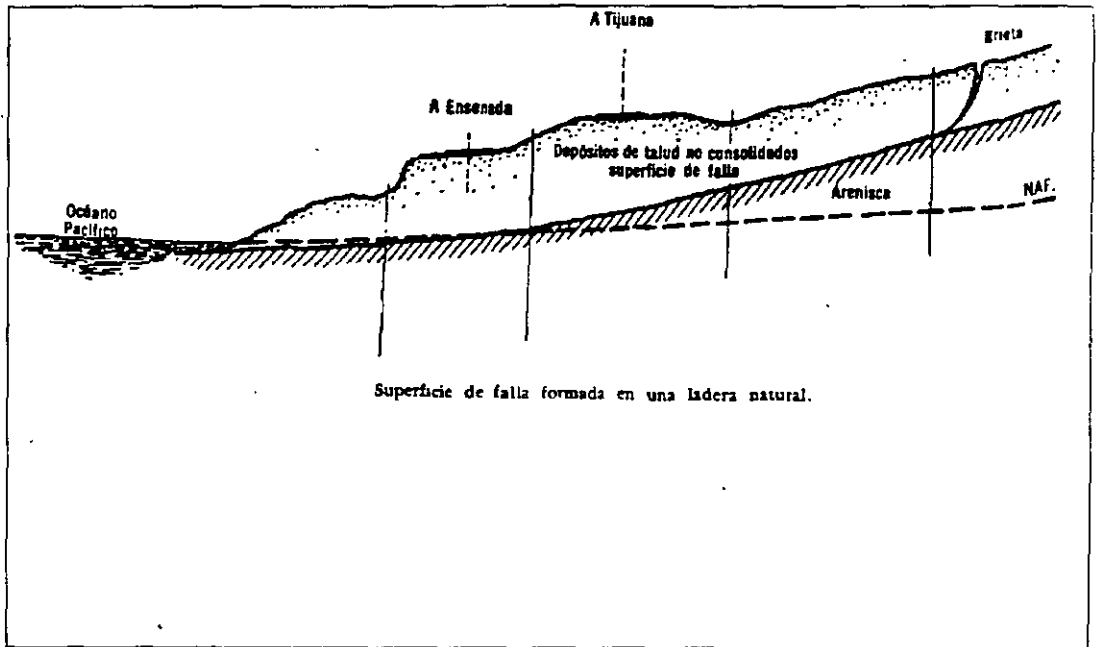

4.3.- Flujos.

Se refiere éste tipo de falla a movimientos más o menos rápidos de una parte de la ladera natural, de tal manera que el movimiento en sí y la distribución aparente de velocidades y desplazamientos recuerda el comportamiento de un líquido viscoso. La superficie de desplazamiento no es discernible o se desarrolla durante un lapso relativamente breve; es también frecuente que la zona de contacto entre la parte móvil y las masas fijas de la ladera sea una zona de flujo plástico.

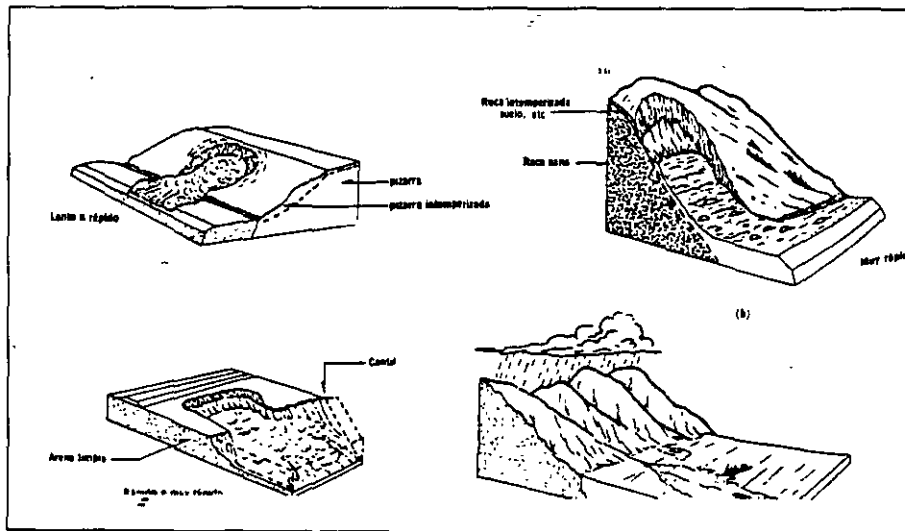

5.- Fallas Relacionadas a la Estabilidad de Taludes Artificiales.

5.1.- Falla Rotacional.

Se describen ahora los movimientos rápidos o prácticamente instantáneos que ocurren en los taludes y que afectan a masas profundas de los mismos, con deslizamiento a lo largo de una superficie de falla curva que se desarrolla en el interior del cuerpo del talud, interesando o no al terreno de cimentación.

Se considera que la superficie de falla se forma cuando en la zona de su futuro desarrollo actúan esfuerzos cortantes que sobrepasan la resistencia del material. La resistencia que se debe considerar en cada caso particular es una cuestión muy importante. La resistencia que se supone superada al producirse una falla rotacional es generalmente la resistencia máxima. Así pues, en el interior del talud existe un estado de esfuerzos cortantes que vence en forma mas o menos rápida la resistencia al esfuerzo cortante del suelo; a consecuencia de ello sobreviene la ruptura del mismo, con la formación de una superficie de deslizamiento, a lo largo de la cual se produce la falla.

Las fallas del tipo rotacional pueden producirse a lo largo de superficies de falla identificables con superficies cilíndrica o concoidales cuya traza con el plano del papel sea una arco de circunferencia (por lo menos, con razonable aproximación, la cual, como se verá resulta muy conveniente en el momento en que se desee establecer un modelo matemático de la falla, que permita un cálculo numérico) o pueden adoptar formas muy diferentes, en las que por lo general influyen la secuencia geológica local, el perfil estratigráfico y la naturaleza de los materiales.

Desde luego las fallas rotacionales de forma circular ocurren por lo común en materiales arcillosos homogéneos o en suelos cuyo comportamiento mecánico esté regido básicamente por su fracción arcillosa. En general afectan a zonas relativamente profundas del talud, siendo ésta profundidad mayor, cuanto más escarpado sea aquel. Cuando las laderas son muy tendidas, las superficies de falla pueden desarrollarse con poca profundidad. Las fallas rotacionales circulares pueden ser de cuerpo de talud o de base; las primeras se desarrollan sin interesar al terreno de cimentación, en tanto que las segundas se desarrollan parcialmente en él.

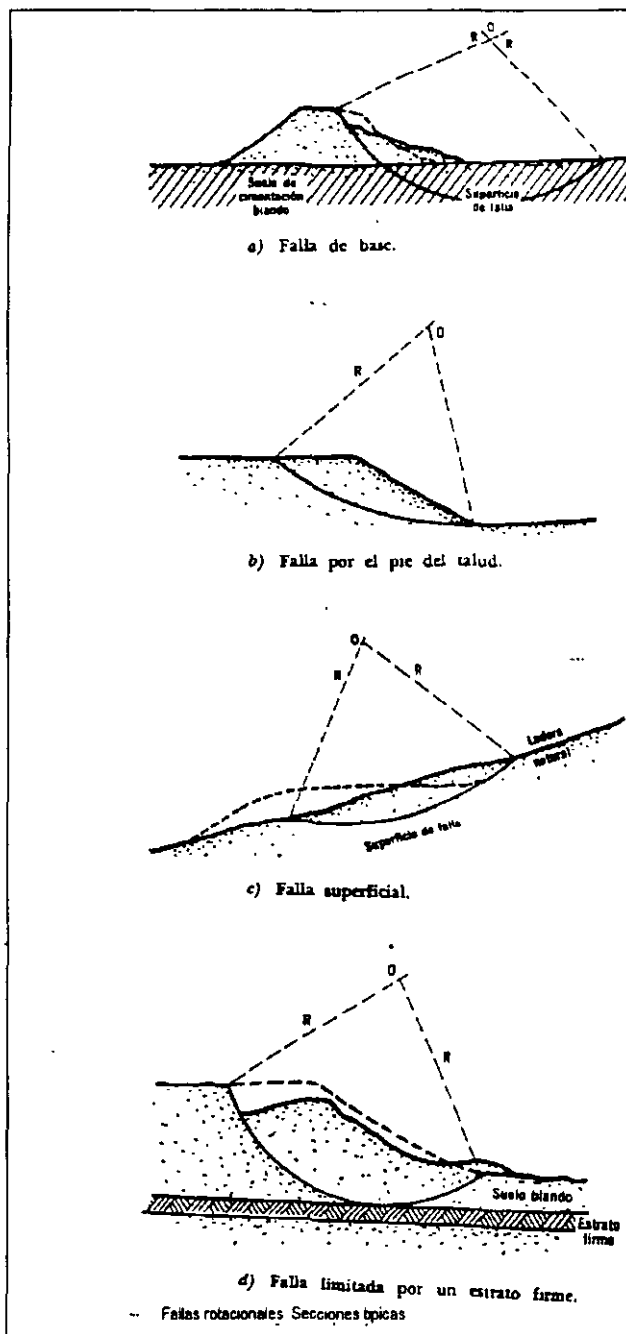

= -

= -

Al ocurrir las fallas circulares pueden afectar a masas muy anchas; en comparación con las dimensiones generales de la falla, en cuyo caso dan lugar a verdaderas superficies cilíndricas, o pueden ocurrir en forma concoidal, con un ancho pequeño comparado con su longitud.

Las fallas rotacionales de forma distinta a la circular típica parecen estar asociadas sobre todo a arcillas sobreconsolidadas que se presentan en taludes no homogéneos, por diferencias en la meteorización, por influencia de la estratificación o por otras causas que se reflejen en discontinuidades o en desorden estructural del talud

5.2.- Falla Translacional.

Estas fallas por lo general consisten en movimientos translacionales importantes del cuerpo del talud sobre superficies de falla básicamente planas, asociadas a la presencia de estratos poco resistentes localizados a poca profundidad bajo el talud.

La superficie de falla se desarrolla en forma paralela al estrato débil y se remata en sus extremos por dos cantiles, formados por lo general por agrietamientos.

Los estratos débiles que fomentan éstas fallas son por lo común de arcillas blandas o de arenas finas o limos no plásticos sueltos. Con mucha frecuencia, la debilidad del estrato está ligada a elevadas presiones de poro en el agua contenida en las arcillas o a fenómenos de elevación de presión de agua en estratos de arena (acuíferos). En este sentido, las fallas pueden estar ligadas al calendario de las temporadas de lluvias en la región.

Las fallas del material en bloque muchas veces están asociadas a discontinuidades y fracturas de los materiales que forman un corte o una ladera natural, siempre en añadidura al efecto del estrato débil subyacente.

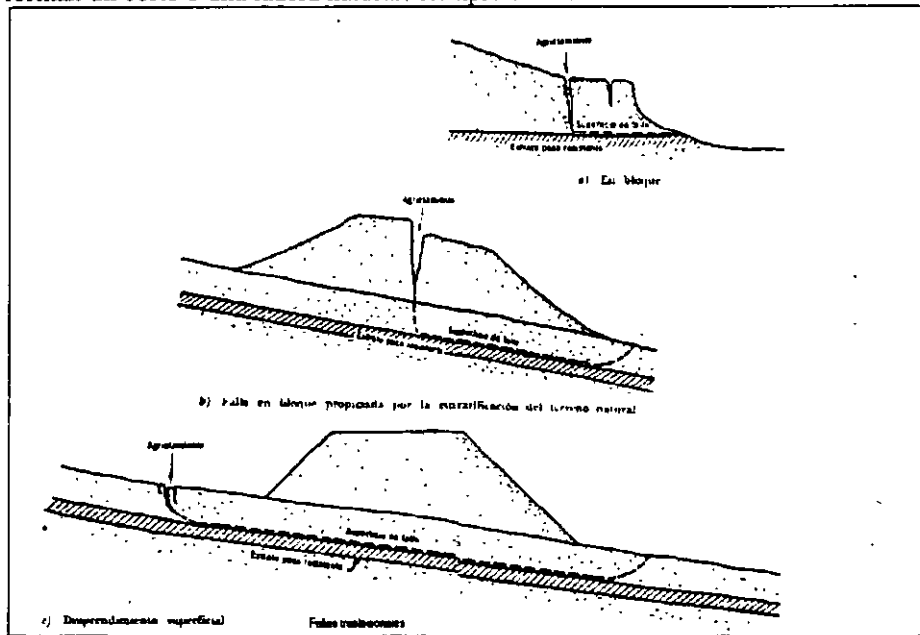

Las fallas de una franja superficial son típicas de laderas naturales formadas por materiales arcillosos producto de la meteorización de formaciones originales. Se suelen provocar por el efecto de la sobrecarga impuesta por un terraplén construido sobre la ladera. En estas fallas el movimiento ocurre casi sin distorsión.

5.3.- Fallas con Superficie Compuesta y Fallas Múltiples.

Existen tipos de fallas que abarcan movimientos en que se combinan la translación y la rotación, dando origen a superficies de falla compuestas en que se desarrollan zonas planas a la vez que tramos curvos, asimilables a arcos circulares.

≡

≡

Así mismo se distinguen fallas que se producen con varias superficies de deslizamiento, sean simultáneas o en rápida sucesión.

5.4.- Derrumbes y Caídos.

Estas fallas son típicas tanto de las laderas naturales como de los cortes practicados en ellas. Por lo general consisten en desprendimientos locales de no muy grande volumen. En estas fallas no puede hablarse de una superficie de deslizamiento y el desprendimiento suele estar predeterminado por las discontinuidades y fisuras preexistentes.

5.5.- Otros tipos de fallas, no directamente asociadas a la resistencia al esfuerzo cortante de los suelos.

Existen fallas por erosión, fallas por tubificación y fallas por agrietamiento. En el aspecto de análisis que involucra a los taludes conformados por rellenos sanitarios, es muy importante profundizar un poco en las fallas por tubificación.

La situación típica que expone un terraplén a la tubificación es que por algún motivo aquél embalse agua durante un lapso considerable, suficiente para que se establezca un flujo a su través. Que el terraplén embalse es, sin duda, una condición que se presenta con relativa frecuencia, pero seguramente es bastante más raro que el terraplén quede durante mucho tiempo expuesto a la acción de agua en sus dos taludes, con tirante diferente y desnivel importante, de manera que pueda establecerse un flujo con gradiente hidráulico suficientemente alto para generar problemas de tubificación.

La tubificación comienza cuando hay arrastre de partículas de suelo en el interior de la masa por efecto de las fuerzas erosivas generadas por el flujo de agua. Una vez que las partículas empiecen a ser removidas van quedando en el suelo pequeños canales, por los que el agua circula a mayor velocidad, con mayor poder de arrastre, de manera que el fenómeno de tubificación tiende a crecer continuamente una vez que comienza, aumentando siempre el diámetro de los canales que se van formando en el interior del terraplén.

El límite del fenómeno es el colapso del bordo, al quedar éste surcado por huecos de diámetro suficiente para afectar la estabilidad por disminución de sección resistente.

Un factor que influye mucho a la tubificación es la insuficiencia de compactación en el terraplén, cuando ésta afecta a suelos susceptibles. Esta insuficiencia es común, sobre todo en la vecindad de muros o superficies rígidas, tales como ductos o alcantarillas.

Teniendo en cuenta que las alcantarillas son lugares en donde es común que exista tirante de agua y en torno a los cuales es difícil compactar los suelos, se puede afirmar que se trata de puntos críticos en cuanto a tubificación se refiere. Alrededor de ellas se deberá vigilar muy especialmente la susceptibilidad de los materiales que se empleen.

6.- Métodos de Cálculo de Estabilidad de Taludes.

Se tratará ahora de presentar un método de cálculo para establecer si un talud en que se piensa será estable en la etapa de proyecto, o para poder revisar la condición de un talud construido y poder juzgar, quizá, de la bondad de algún modelo correctivo que se desee emplear.

Antes de proseguir ha de insistirse en que, todos los modelos matemáticos que sirven de base a métodos de cálculo presuponen una homogeneidad en materiales, estratificación, disposición, circunstancias y modo de actuar de los agentes naturales que muy pocas veces se presentan en las obras reales.

6.1.- Falla Rotacional. Método Sueco.

Los métodos de análisis límite disponibles para calcular la posibilidad de que se desarrolle un deslizamiento de tipo rotacional en el cuerpo de un talud, al igual que prácticamente todos los métodos de cálculo de estabilidad de taludes, siguen tres pasos fundamentales:

- 1.- Se establece una hipótesis sobre el mecanismo de la falla que se producirá. Ello incluye tanto la forma de la superficie de la falla como una descripción cinemática completa de los movimientos que se producirán sobre ella y un análisis detallado de las fuerzas motoras.
- 2.- Se adopta una ley de resistencia para el suelo. Con base en tal ley se podrán analizar las fuerzas resistentes disponibles.
- 3.- Se establece algún procedimiento matemático de "confrontación", para definir si el mecanismo de falla propuesto podrá ocurrir o no bajo la acción de las fuerzas motoras, venciendo el efecto de las fuerzas resistentes.

La razón para que se utilice un método como el anterior es que no se ha desarrollado ninguno satisfactorio con base a una hipótesis convincente de distribución de esfuerzos en el interior de la masa del talud.

En la siguiente sección se describirá el procedimiento matemático en cuestión, que es el método sueco aplicado a taludes cuya ley de resistencia se exprese en términos de la cohesión y el ángulo de fricción interna del suelo, así como la presión de poro.

El método de cálculo que se describirá es el método de las dovelas, sugerido por Fellenius y ampliamente empleado en análisis prácticos en el caso estático.

La descripción se hará con base en la figura siguiente.

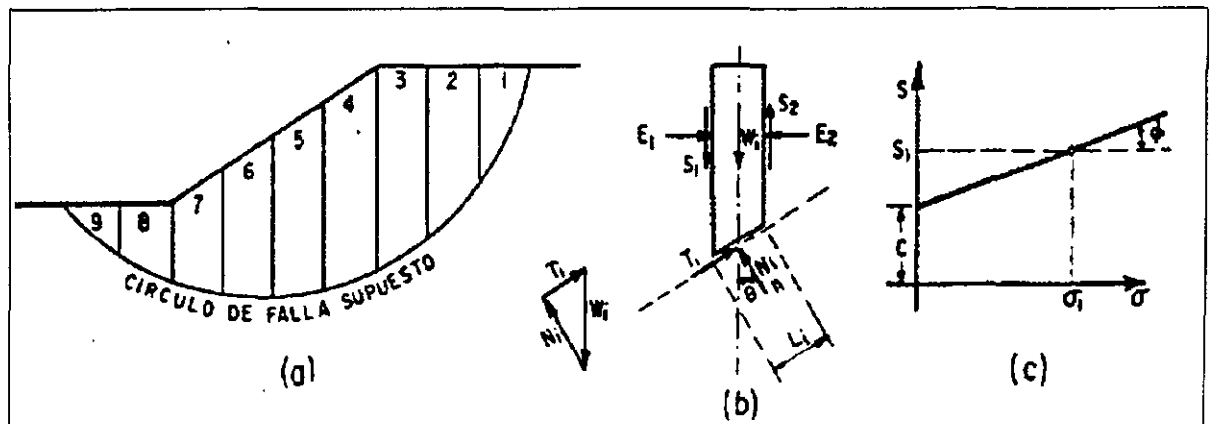

En primer lugar se propone un círculo de deslizamiento y la masa deslizante se divide en dovelas como las que se muestran en la figura. En la parte (b) de la misma figura aparece el conjunto de fuerzas que actúan en una dovela, cuando la masa deslizante está situada sobre el nivel freático y no se toman en cuenta fuerzas de agua en el análisis. Las fuerzas en cada dovela, al igual que en todo el conjunto de la masa deslizante, deben estar en equilibrio. Sin embargo, las fuerzas E y S , actuantes en los lados de las dovelas, dependen de las características esfuerzo-deformación del material y no se pueden evaluar rigurosamente; para poder manejarlas es preciso hacer una hipótesis razonable sobre su valor.

La hipótesis más simple a éste respecto es que el efecto conjunto de las cuatro fuerzas laterales es nulo y que, por lo tanto, esas fuerzas no ejercen ningún papel en el análisis; de hecho ésta fué la hipótesis de Fellenius en el procedimiento de cálculo original que presentó, que equivale a considerar que cada dovela actúa independiente de las demás y que las componentes N_i y T_i equilibran al peso W_i de la dovela i -ésima (ver figura).

Para cada dovela se puede calcular el cociente

$$\frac{N_i}{L_i}$$

el cual se considera una buena aproximación al valor de σ_c , que es el esfuerzo total medio actuante en la base de la dovela. Con éste valor de σ_c puede entrarse a la ley de resistencia, al esfuerzo cortante que se haya encontrado para el material (por lo general en éste caso, una ley ligada a los esfuerzos totales) y determinar en ella el valor de s_c , resistencia al esfuerzo cortante media disponible en el arco L_i .

Ahora se puede calcular un momento motor en torno al punto O, centro del círculo elegido para el análisis, correspondiente al peso de las dovelas; éste momento será:

$$M_m = R \sum |T_i|$$

Nótese que la componente normal del peso de la dovela N_i , no da momento respecto a O por ser la superficie circular y pasar por O su línea de acción. Si hubieren sobrecargas en la corona del talud, su efecto se incluiría en la suma de la ecuación. Nótese también que la suma en la ecuación anterior, es algebraica, pues para las dovelas situadas más allá de la vertical que pasa por O, la componente del peso actúa en forma contraria, tendiendo a equilibrar la masa.

El momento resistente depende de la resistencia al esfuerzo cortante s_c que se desarrolla en la base de las dovelas. Así pues que

$$M_r = R \sum s_c L_i$$

es una suma aritmética, pues la resistencia siempre actúa en el mismo sentido.

Calculados M_m y M_r , se podrá definir un factor de seguridad:

$$F_s = \frac{M_r}{M_m} = \frac{\sum s_c L_i}{|T_i|}$$

El método de cálculo desemboca naturalmente, otra vez, en un método de tanteos, siendo preciso encontrar el círculo crítico, con el factor de seguridad mínimo. Se deberán analizar tanto los círculos de falla de pie del talud como los de falla de base.

En la ingeniería de suelos es común aceptar en éste caso factores de seguridad de 1.2 o 1.3 en los casos normales y de 1.5 cuando se desee tener mayor seguridad en la estabilidad; éste último es el valor que por lo común se recomienda en la literatura para taludes en general.

Con frecuencia se presentan en la práctica taludes formados por suelos estratificados. La masa deslizante se podrá considerar dividida en dovelas, dibujadas de manera que ninguna base de dovela caiga entre dos estratos, sino que cada dovela caiga sobre un sólo material. El peso de la dovela deberá calcularse con sumandos parciales multiplicando la parte del área que caiga en cada estrato por el peso volumétrico correspondiente.

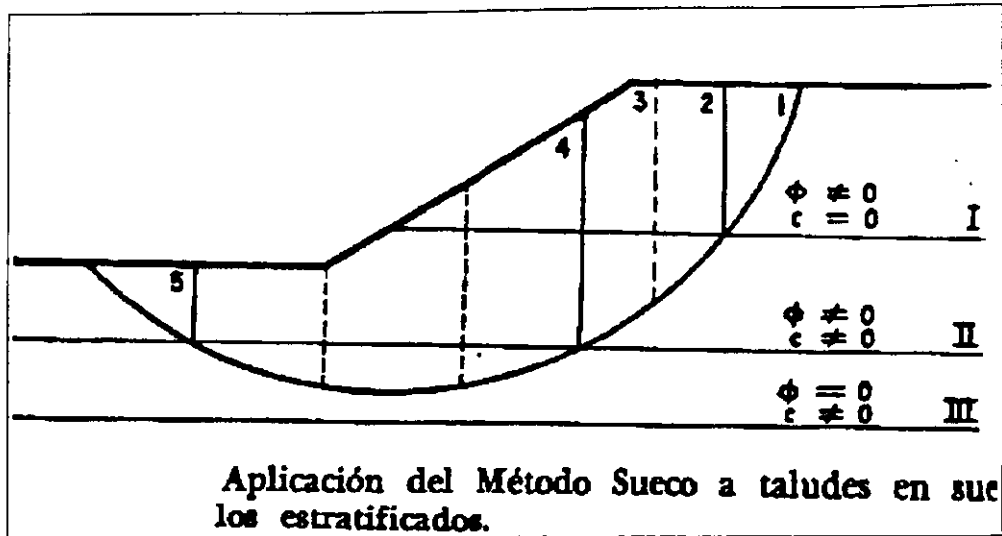

El problema se puede resolver utilizando para cada dovela la ley de resistencia al esfuerzo cortante que corresponda, de acuerdo con la naturaleza del material.

El resto del desarrollo del método es análogo enteramente al que se vió para taludes homogéneos. El problema se deberá resolver siempre por tanteos, pues para éste caso no hay gráficos de uso común. La búsqueda del círculo se podrá facilitar bastante si hay estratos mucho menos o mucho más resistentes que los demás; en el primer caso, es probable que el círculo crítico sea el que tenga el máximo desarrollo en el estrato débil; en el segundo, probablemente será tangente al estrato resistente, pues al penetrar en él se incrementaría mucho la resistencia media.

6.2.- Casos Distintos.

Debido a la corta duración de éste curso, no se podrá profundizar en los casos en que el análisis haya que hacerse con esfuerzos efectivos, para taludes situados total o parcialmente bajo el nivel freático o sometidos a una condición de flujo. Este tipo de análisis habrá de efectuarse con base en esfuerzos efectivos, que se obtengan de una prueba triaxial con consolidación y con drenaje (lenta) o con consolidación y sin drenaje (rápida consolidada), que se realice con medición de presiones de poro en el plano de falla en el instante de la falla.

7.- Factores que Producen Fallas de Estabilidad de Laderas y Taludes.

Con frecuencia las propias manipulaciones del ingeniero pueden ser fuente de graves problemas de estabilidad de taludes; la lista que se proporciona a continuación es una reseña de los procesos constructivos que más comunmente causan problemas.

- 1.- Modificación de las condiciones naturales de flujo interno del agua al colocar rellenos o hacer zanjas o excavaciones.
- 2.- Sobrecarga de estratos débiles por relleno, a veces de desperdicios.
- 3.- Sobrecarga de terrenos con planos de estratificación desfavorables por relleno.
- 4.- Remoción, por corte, de algún estrato delgado de material permeable que funcionara como un manto

- 5.- Aumento de presiones de filtración u orientaciones desfavorables de fuerzas de filtración al producir cambios en la dirección del flujo interno del agua, por haber practicado cortes o construido rellenos.
- 6.- Exposición al aire y al agua, por corte, de arcillas duras fisuradas.
- 7.- Remoción de capas superficiales de suelo por corte, lo que puede causar el deslizamiento de capas del mismo estrato ladera arriba, sobre mantos subyacentes de suelo más duro o roca.
- 8.- Incremento de cargas hidrostáticas o niveles piezométricos bajo la superficie de un corte al cubrir la cama del mismo con una capa impermeable.

8.- Caso Práctico.

A continuación se presenta un caso práctico, a través de un talud en proporción 2:5 (horizontal-vertical), en donde se han propuesto cuatro círculos de falla.

Los círculos 1 y 2 corresponden a fallas de base en diferentes proporciones.

El círculo 3 es una falla intersectando terreno de cimentación y el círculo 4 es una falla de cuerpo de talud.

Se analizó la estabilidad de taludes modificando las propiedades gravivolumétricas y de resistencia al esfuerzo cortante de el suelo que compone el estrato N° 1 (superior), considerando condiciones dramáticamente desfavorables para el estrato N° 2 (inferior).

Los resultados pueden observarse en las tablas anexas.

11111111

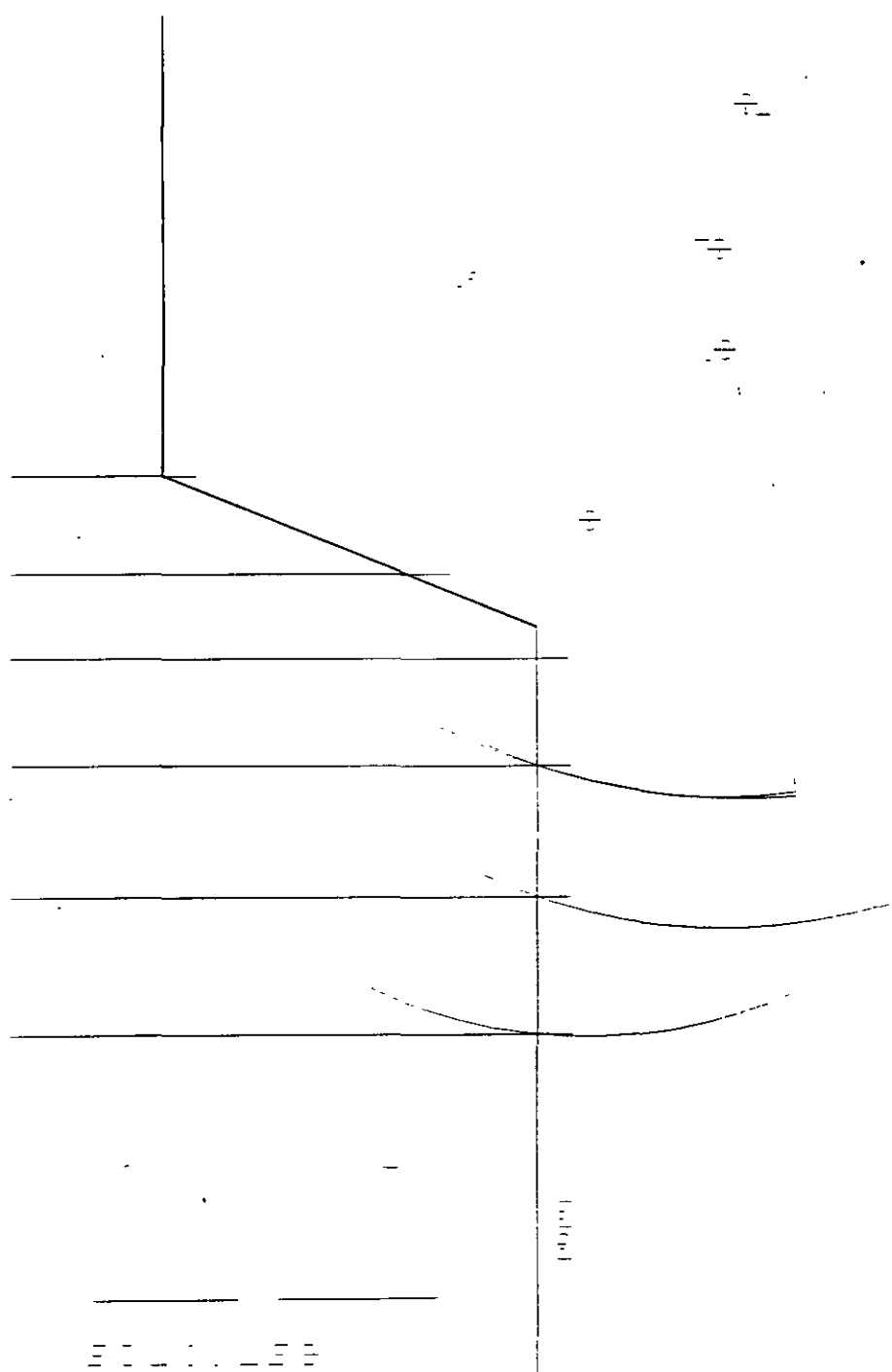

11111111

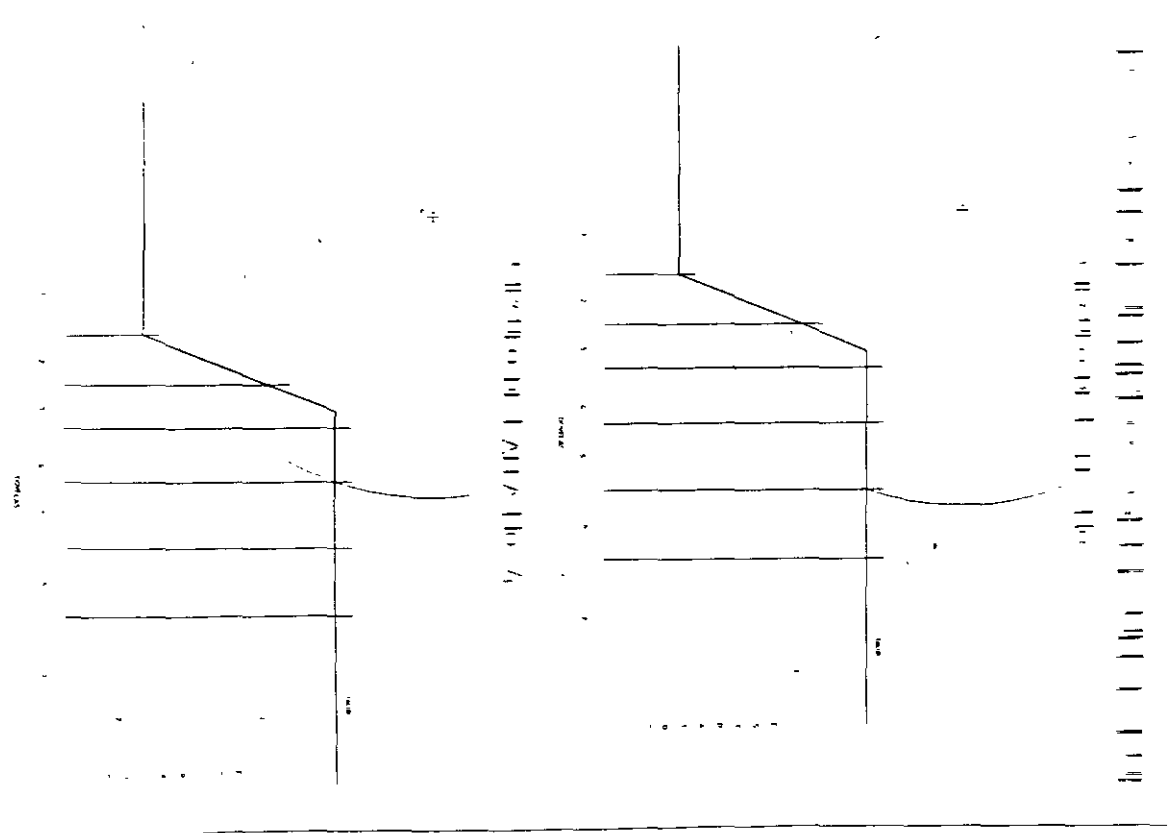
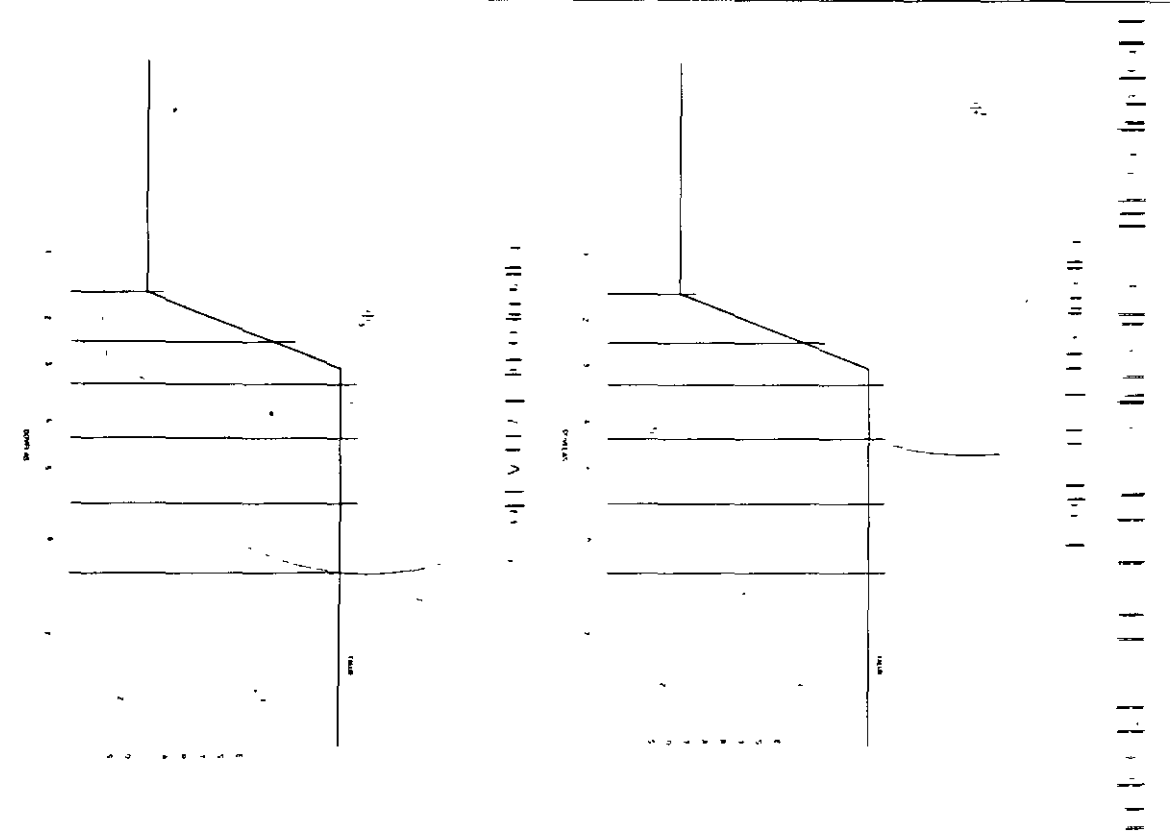

Análisis de Factores de Seguridad para el Talud Propuesto como Ejemplo.

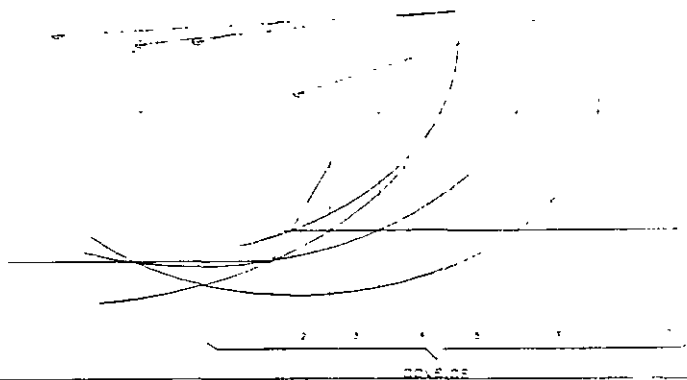

	Estrato 1	Estrato 2
Peso Volumétrico (γ), ton/m ³	1.6	1.1
Cohesión (C), ton/m ²	2.1	0
Angulo de Fricción (ϕ), grados	10	22
	Círculo N°	Factor de Seguridad
	1	1.51
	2	1.32
	3	1.29
	4	2.08

Observaciones
Valores característicos (estrato 1) de un limo arenoso "tepetate" compactado deficientemente.

	Estrato 1	Estrato 2
Peso Volumétrico (γ), ton/m ³	1.6	1.1
Cohesión (C), ton/m ²	3	0
Angulo de Fricción (ϕ), grados	15	22
	Círculo N°	Factor de Seguridad
	1	2.14
	2	1.78
	3	1.52
	4	2.89

Observaciones
Valores característicos (estrato 1) de un limo arenoso "tepetate", compactado al 90 o 95 %.

	Estrato 1	Estrato 2
Peso Volumétrico (γ), ton/m ³	1.133	1.1
Cohesión (C), ton/m ²	1.27	0
Angulo de Fricción (ϕ), grados	3.74	22
	Círculo N°	Factor de Seguridad
	1	1.24
	2	1.11
	3	1.25
	4	1.69

Observaciones
Valores promedio de arcilla de origen lacustre (similar a la zona Aragón-Lago de Texcoco)

	Estrato 1	Estrato 2
Peso Volumétrico (γ), ton/m ³	1.566	1.1
Cohesión (C), ton/m ²	9.1	0
Angulo de Fricción (ϕ), grados	13	22
	Círculo N°	Factor de Seguridad
	1	6.03
	2	4.5
	3	2.96
	4	8.65

Observaciones
Valores extremos de un material húmedo y compactado casi al máximo



**FACULTAD DE INGENIERIA U.N.A.M.
DIVISION DE EDUCACION CONTINUA**

CURSOS ABIERTOS

**“ IX CURSO INTERNACIONAL DE
CONTAMINACIÓN DE ACUÍFEROS “**

MODULO.III

MODELOS MATEMÁTICOS EN GEOHIDROLOGÍA

TEMA

HERRAMIENTAS INFORMÁTICAS

**EXPOSITOR: ING. FEDERICO MEIXUERIO T.
1997**

IX CURSO INTERACIONAL DE CONTAMINACION DE ACUIFEROS
MODULO III: Modelos Matemáticos en Geohidrología.

Tema: **SURFER.**

1.- Introducción.

El programa SURFER, versión 4.12, generado por Golden Software, Inc. se presenta en este módulo como una herramienta indispensable para la ingeniería, por su capacidad de convertir una matriz de vectores de posición tridimensional, en un mapa de contorno o en una representación de superficie tridimensional, para su almacenamiento en disco, para su presentación o para una impresión en dispositivo externo.

El programa SURFER viene equipado con una serie de herramientas, accesorios, tipos de letra, utilerías y un programa de acceso a los 5 programas que conforman el núcleo principal del SURFER.

Tales programas son:

a) Utilerías:

ALTERSYM.EXE	Programa de modificación de los juegos de símbolos (Symbol Set).
GRAFIT.EXE	Generador de gráficos por medio de una hoja electrónica de gran simplicidad para salida en formato .PLT.
GRIDCONV.EXE	Convierte mallas (grids) del Microsoft Basic al formato IEEE.
INSTALL.EXE	Programa de configuración de dispositivos externos.

b) Programas-Núcleo:

SURFER.EXE	Sistema de acceso por medio de menús para acceder los múltiples programas y utilerías del SURFER.
GRID.EXE	Crea una malla regularmente espaciada a partir de datos irregularmente espaciados o por medio de una función definida por el usuario.
TOPO.EXE	Crea mapas de contorno a partir de archivos de malla generados por GRID.
SURF.EXE	Crea trazos de superficie tridimensional a partir de un archivo de malla generado por GRID.
UTIL.EXE	Es un programa que realiza varias funciones en archivos de malla generados por GRID (incluye las funciones de las utilerías SLIDE y VOLUME en versiones anteriores de SURFER).
VIEW.EXE	Muestra un archivo de impresión (plot) generado a partir de TOPO o SURF. El diagrama puede ser modificado dimensionalmente (pan y zoom).
PLOT.EXE	Programa que manda a impresión un archivo generado por TOPO o SURF. También puede configurarse para mandar la impresión a un archivo.

2.- Programa GRID.

2.1.- Generalidades.

Como ya se mencionó anteriormente, el programa GRID genera archivos (en formato binario o ascii) para ser leídos por porciones de código subsecuentes, con otras funciones colaterales.

El programa contiene opciones relativa a la creación de una malla a partir de una matriz de vectores de posición (asociados a un sistema rectangular de coordenadas), generada de manera irregular o a través de una función matemática.

Por ejemplo, el programa GRID podrá procesar ternas de valores reales o enteros y asociarlos internamente con un vector de posición en un sistema coordenado rectangular XYZ. De igual manera, podrá hacer uso de un sencillo editor de ecuaciones de dos variables para generar las ternas de posición; así que podrá definir una función continua $z = f(x,y)$.

Usualmente el primer paso consiste en incorporar ternas al programa GRID. La opción Input aceptará datos tanto del teclado como de diferentes tipos de archivos de datos. Después de aceptados los datos, las otras opciones del menú consisten en controlar el proceso de generación de malla regularmente espaciada.

2.2.- Métodos de Generación de la Malla.

El programa proporciona dos métodos diferentes de generación de una malla regularmente espaciada, el método del inverso de la distancia y el método Kriging. El método del inverso de la distancia es más rápido pero no representa los datos originales tan precisamente como el Kriging.

El método del inverso de la distancia utiliza una técnica de promedio ponderado para interpolar los nodos de la malla a partir de los vectores de posición. Las influencias son inversamente proporcionales a las distancias a los nodos. Además, las influencias pueden elevarse a una potencia para incrementar el efecto de la función ponderadora. El inverso de la distancia al cuadrado es el método más común.

El método del Kriging utiliza técnicas geoestadísticas para calcular la autocorrelación entre puntos y producir una mínima e imparcial variancia estimada. En teoría ningún otro método de generación de mallas puede producir estimados más precisos. En práctica, la efectividad del método del Kriging depende de la correcta selección de varios parámetros. Tales parámetros son estimados por el GRID y pueden no ser exactos. Aún así, el Kriging produce mapas más precisos que los generados a través del método del inverso de la distancia.

2.3.- Métodos de Normalización de la Malla.

El programa proporciona dos métodos de normalización o uniformización de las mallas generadas, el método matricial y el método de ajuste.

El método de normalización matricial evalúa una matriz de normalización sobre la malla existente para promediar aquellos puntos de la malla más cercanos a cada punto de la malla que va a normalizarse. La matriz se especifica por el número de columnas y de renglones a cada lado del punto de la malla a normalizarse, así como la influencia al punto central de la matriz.

	1	2	3	4	5	6	7
1	+	+	+	+	+	+	+
2	+	x	x	x	x	x	+
3	+	x	x	o	x	x	+
4	+	x	x	x	x	x	+
5	+	+	+	+	+	+	+

En el ejemplo anterior, los signos + representan los nodos de la malla, mientras que las x y las o representan a la matriz de normalización. La malla es de 5 renglones por 7 columnas, mientras que la matriz de normalización es de 3 renglones por 5 columnas. El nodo de la malla que está siendo normalizado está en el renglón 3 y la columna 4.

Cada nodo de la malla bajo una x será ponderado por el valor de la matriz de normalización y promediado para obtener un nuevo valor para el nodo central de la malla. La matriz cambiará por ello y el proceso se repetirá hasta que la malla entera se normalice. Nótese que las orilla de la malla no están definidas y quedarán sin cambio.

Para una normalización ponderada no por la distancia, los nodos x tendrán una influencia de 1.0 y el nodo o se le asignará como el punto central de la influencia. En la normalización basada en la distancia, se le asignarán influencias a cada x basadas en el inverso de la distancia al centro, elevadas a la correspondiente potencia.

En el método de ajuste, la normalización se basa en el ajuste a través de un polinomio de grado cúbico para interpolar nuevos valores entre nodos existentes de la malla. Esto incrementa la densidad de la malla permitiendo contornos y superficies más suaves. Los factores de expansión en X y en Y se refieren al número de puntos a insertar entre los nodos existentes en las direcciones X y Y respectivamente. Este tipo de normalización podría incrementar las bajas y altas de la malla original.

*	.	*	.	*	.	*	.	*
.
.
*	.	*	.	*	.	*	.	*
.
.
*	.	*	.	*	.	*	.	*

En el ejemplo anterior, los asteriscos representan la malla original de 3 por 5. Los nodos representados por los puntos fueron interpolados usando una normalización por medio de un ajuste a una curva polinomial cúbica. 1 puntos fué calculado entre cada nodo en la dirección X y 2 puntos fueron calculados entre cada nodo en la dirección Y, para arrojar una malla final de 7 renglones por 9 columnas.

3.- Programa TOPO.

El programa TOPO es un generador de contornos que funciona por medio de menús. El trazo del contorno puede observarse en el monitor de la computadora, mandarse a impresión o mandarse a un archivo. Los parámetros de generación del mapa de contorno y de impresión pueden controlarse en su totalidad por el usuario.

Los datos de la malla deberán estar en el formato utilizado por el programa GRID, el cual está en formato ascii o en binario. El acceso al programa TOPO podrá ser desde la línea de comandos del DOS o desde el menú del SURFER.

4.- Programa SURF.

Este programa es un programa interactivo, controlado por menús que produce representaciones de superficies tridimensionales para su salida a la pantalla, impresora, plotter o archivo. La entrada para este programa está conformada por los archivos de extensión .GRD generados por el GRID en base a datos proporcionados por el usuario.

A semejanza del TOPO, el SURF contiene una gran cantidad de opciones alternas, como ejes, colores, títulos, complementación con otros gráficos, opciones de control de generado de superficies y muchas otras opciones.

5.- Programa UTIL.

Este programa realiza varias funciones en archivos de malla generados por el programa GRID.

Entre tales funciones, se pueden encontrar las siguientes:

- Volume:** Calcula volúmenes de sólidos generados por superficies limitadas por una malla.
- Slice:** Genera secciones de una superficie limitada por una malla para un archivo BLN o para un archivo de datos para GRAPHER.
- Residuals:** Calcula los residuos de un conjunto de datos de una superficie limitada por una malla
- Convert:** Convierte un archivo de malla a un archivo de datos.
- Area-of-a-Surface:** Calcula el área superficial de una malla.
- Environ:** Especifica la configuración del hardware.

Volume.

Este programa calcula el volumen neto entre las superficies definidas (superior e inferior), calculándolo a través de una doble integral, evaluando la diferencia entre el volumen positivo y el volumen negativo.

Métodos de cálculo.- Para el cálculo del volumen neto se utilizan tres métodos: Regla del Trapezoide, la Regla de Simpson y la Regla de Simpson 3/8 (véase anexo). Para un estimado de los errores, pueden compararse los resultados de los tres métodos.

Atención: Los resultados dependen de las superficies de malla proporcionadas, si la superficie es obtenida tan sólo de un puñado de datos o bien contiene mucho ruido, los resultados de aplicar éste programa no tendrían sentido.

Slice.

Dado un archivo en el formato de Línea de Frontera (BLN) que contenga líneas que crucen una región especificada por una superficie generada por GRID, producirá lo siguiente:

Un nuevo archivo de frontera BLN con puntos insertados por cada cruce con líneas de la malla.

Un archivo de datos DAT conteniendo datos X, Y, Z en columnas 1, 2, 3 y la distancia en la columna 4.

Residuals.

Residuals calculará a un archivo de malla generado por GRID, y un archivo de datos, generará un archivo de datos de residuos de la superficie y proporcionará la media y la desviación estándar de tales residuos.

6.- Programa VIEW.

El programa VIEW es un subprograma que le permite observar detalles del gráfico generado (mediante sencillos comandos de "zoom" y "pan"), así como permitir la generación por pasos. Esto es, observar mediante control del usuario, la generación de las líneas que componen el trazo.

Este programa acepta archivos de extensión .PLT y no genera nada.

7.- Programa PLOT.

Este subprograma genera salidas a impresora, plotter o archivo previo procedimiento de "optimización", convirtiendo el archivo de salida .PLT generado por TOPO o SURF en un archivo .OPT, preparado para la impresora o dispositivo especificado en la configuración del programa PLOT.

Dentro del programa PLOT se pueden controlar varios parámetros, tales como factores de escala, posición del gráfico dentro de la página, el formato del archivo, el número de dígitos de exactitud del trazado, etc.

APENDICES.

Apéndice 1.- Tipos de Archivos que Maneja el SURFER.

El SURFER trabaja con una serie de archivos, formateados para una función específica. tales archivos son diferenciados internamente mediante una extensión característica. En la tabla siguiente se muestran tales extensiones con una breve descripción de los archivos, así como su génesis y utilización.

Extensión	Uso
.PLT	Archivos de trazo (plot) de cualquier índole, bien generados por TOPO como por SURF. Son leídos por PLOT o dentro de las utilerías de impresión de TOPO o de SURF (que no son sino llamadas a PLOT), para ser procesados.
.OPT	Archivos de optimización para impresión. Son procesados por PLOT y listos para su envío a los dispositivos generadores de impresión.
.SYM	Archivo que contiene un juego de caracteres en un determinado tipo de letra. Pueden crearse y editarse mediante utilerías.
.BLN	Archivo que contiene las denominadas "líneas de frontera", que pueden ser en código ASCII y que representan un polígono bidimensional que se implanta en un mapa de contorno o en la generación de una superficie. Puede generarse externamente al SURFER.
.DAT	Archivo que contiene datos (vectores de posición, localización de puntos, datos para un contorno o vértices de un polígono); puede estar en ascii o en binario. Este tipo de archivos son leídos por GRID, SURF y TOPO.
.GRD	Archivos que contienen (en ascii o en binario) la malla regularmente espaciada que será leída por TOPO o por SURF y que es generada únicamente por el GRID.

Apéndice 2.- Menús de Ayuda.

Todos los programas del SURFER (programas-núcleo) contienen un menú de ayuda (tecleando F1), así como una ayuda sensitiva al contexto.

A pesar de que el programa se encuentra en una versión bastante primitiva, las ayudas se presentan medianamente inteligibles, para el usuario latinoamericano con conocimiento regular del inglés técnico.

Apéndice 3.- Requerimientos para el SURFER.

El SURFER puede copiarse íntegramente en un disco de 3.5 pulg. de alta densidad (1 44 Mb) y ejecutarse en la unidad de disco flexible de cualquier computadora serie 286 y posterior sin ninguna dificultad. Tal computadora de preferencia deberá contar con 1.0 Mb o más de memoria RAM.

Probablemente no tendrá usted problemas para desplegar sus diagramas en el monitor, puesto que entre las versiones de configuración que el SURFER presenta, se contempla un driver automático de detección de modo de video, así como los drivers típicos para los modos CGA, EGA y VGA, así como para los modos Hercules y Olivetti.

Esta versión no soporta (que lástima), mouses ni tabletas digitalizadoras.

De igual manera, en el programa INSTALL de esta versión, se contemplan 84 impresoras y plotters de las más variadas marcas, incluyendo las impresoras Epson, Okidata, Star, Hewlett Packard, tanto de matriz como láser, aunque de manera bastante general. Así mismo, se presentan opciones para puertos de salida, serial o paralelo, la velocidad de transmisión para el puerto serial y la elección de plumas para los plotters.

Apéndice 4.- Tópicos Relacionados con la Evaluación de Volúmenes.

1.- Cálculo de integrales.

Aunque la existencia de la integral de una función continua se asegura fácilmente por medio de la aplicación de los teoremas fundamentales del cálculo, la evaluación o "cuadratura" de dicha integral no puede realizarse mediante funciones elementales, salvo en casos relativamente raros. Deberán desarrollarse, por consiguiente, métodos de integración numérica y también de estimación de la exactitud de tales aproximaciones numéricas.

Para calcular en forma aproximada la integral

$$J = \int_a^b f(x) dx$$

con $a < b$, se subdivide el intervalo $a \leq x \leq b$ en n partes iguales, cada una de longitud $h = (b-a)/n$, mediante los $n+1$ puntos

$$x_v = a + vh, nh = b - a, v = 0, 1, \dots, n.$$

Entonces,

$$J = \sum_{v=1}^n J_v$$

donde

$$J_v = \int_{x_{v-1}}^{x_v} f(x) dx$$

El problema de calcular la integral J queda reducido al de obtener buenas aproximaciones para las áreas J_v de anchura h en las cuales se ha dividido el área total representada por J .

1.1.- Aproximación mediante rectángulos

La aproximación más directa, sugerida por la definición original de la integral, conduce a la relación

$$J = \sum_{v=1}^n J_v \approx h(f_1 + f_2 + \dots + f_n)$$

donde por brevedad, se ha hecho

$$f_v = f(x_v)$$

1.2.- Aproximaciones refinadas - Regla de Simpson.

Una mejor aproximación se obtiene casi sin esfuerzo adicional si las áreas J_v se aproximan, no mediante franjas rectangulares, sino mediante trapecoides angostos. La fórmula de aproximación (fórmula del trapecoide) es entonces

$$J \approx \frac{1}{2} h(f_0 + f_1) + \frac{1}{2} h(f_1 + f_2) + \dots + \frac{1}{2} h(f_{n-1} + f_n)$$

pues cada valor de la función, excepto el primero y el último, aparece dos veces.

Finalmente, se menciona la famosa aproximación de Simpson, la cual, con poco mayor trabajo conduce a una aproximación mucho más precisa si la cuarta derivada de f existe y es uniformemente acotada en el intervalo dado.

La fórmula de Simpson para $n = 2m$ es

$$J \approx \frac{4h}{3} (f_1 + f_3 + f_5 + \dots + f_{2m-1}) + \frac{2h}{3} (f_2 + f_4 + f_6 + \dots + f_{2m-2}) + \frac{h}{3} (f_0 + f_{2m})$$

Tomado de:

R. Courant y F. John.
 "Introducción al Cálculo y al Análisis Matemático", Vol. I.
 Cap. 6, Métodos Numéricos. pp. 501-505.
 Ed. Limusa, México, 1971, 1ª Ed.

EXTRACTO DEL MANUAL DEL SURFER V. 4.12

Contenido

Programa	Pág.
SURF Menu	1
TOPO Menu	5
UTIL Menu	10
ALTERSYM Menu	13
GRID Menu	16

SURF Menu

SURF is an interactive, menu-driven graphics program that produces three dimensional surface representations for output to the screen, printer, or plotter. Gridded data in the format used by the GRID program is input from a data file in either ASCII or binary format. The fastest way to view a plot on a graphics screen from DOS is to type the command

SURF filename

and press function key F2. filename is any grid file produced by the GRID program, and may include an optional drive and path. If the extension is omitted, GRD will be used. The surface plot will appear on the screen using default values for the contour and plot parameters. To modify the default values press Esc to return to the Main Menu.

Input Menu

You may specify the name of the input grid file and whether to input the entire file or a part of the file corresponding to a subgrid.

Input grid file The input grid file must be a valid DOS filespec consisting of an optional drive, optional path, filename, and optional extension. If the extension is omitted, .GRD is used. The file is read when the popup menu is exited.

First and last These options are used to specify a rectangular subgrid from rows and columns of the original grid file. Rows and columns are numbered starting with 1. The default values of 1 and 32767 will read the entire grid.

View

Protection Orthographic projection is better when measurements are to be taken off the surface. Parallel lines will remain parallel. The perspective projection creates a visual effect similar to that of the human eye. Parallel lines appear to converge at a distance similar to railroad tracks at the horizon.

Rotation This is the number of degrees from the positive X axis. The surface appears to rotate clockwise, or equivalently the viewer's eye appears to rotate counter-clockwise. 0=looking west, 90=south, 180=east, 270=north.

Tilt Tilt specifies the angle above or below the X-Y plane, from which the surface is to be viewed. The default of 30 degrees puts the viewer's eye 30 degrees above the plane.

Surface-Eye Distance Distance of the viewer's eye to the center of the surface. This parameter is used only with perspective projections, and must be large enough so the eye falls outside a circumscribing sphere around the surface. The perspective effect increases with decreasing distance. Note that small distances may cause hidden line errors.

Remove hidden lines Answer Yes to remove lines hidden by surface features closer to the eye. No will bypass the hidden line removal and plot all lines as though the surface were transparent.

Visible surface Enter Upper to plot lines only on the top of the surface, Lower to plot only the lower surface and Both to plot both the upper and lower surfaces.

LineType

Plot constant (X,Y,Z) To plot lines of constant X, Y, and Z enter any combination of the 3 letters X, Y, or Z. Lines of constant Z will create a stacked contour plot, XY lines create a fishnet plot.

Line color Integer from 1 to 15

Minimum Z contour If stacked contour lines are to be plotted, the user may specify the limits and the interval between contours. The maximum Z contour interval must be positive, and the minimum \leq maximum. A maximum of 200 contour levels will be plotted.

Level file (.DAT) ASCII file containing arbitrary values for the levels of stacked contour lines. Values needn't be ordered nor equally spaced. If this file is specified, the previous three responses (min, max, interval) are ignored, and interval is set to "N/A". A maximum of 200 levels are allowed.

Draw border This option is in effect if only Z contours are plotted.

Z Color zone file (.CZN) The user may specify a file containing information for color zones. For example, if the file contains the following three lines

```
50 0 5      then color 5 is used if Z >= 50.0
30.0 2      color 2 is used if 50.0 > Z >= 30.0,
10 0 1      color 1 is used if 30.0 > Z >= 10.0,
and, the color is undefined if Z < 10.0
```

Hence, a contour of level Z = 40.0 will be plotted in color 2, as will a contour of level Z = 30.0.

The values in the file are sorted in increasing order of Z, so you may enter the lines in any order, but it is wise to enter them in either increasing or decreasing order to lessen the chance of a mistake.

With good color choices, considering the colors available on the output device, a nice spectrum of colors may be created, with reds for highs, for example, and blues for lows.

Base

An opaque base may be added to the plot to give the surface a solid block effect.

Plot base Enter Yes to plot a base.

Base height Automatic will set the base height to the minimum Z value of the input grid. Alternatively, the base height may be specified to change the thickness of the base. Large negative values may result in a plot that does not fit on the screen, while large positive values may result in a skirt which obscures the surface. Large bases may require the eye distance in the View menu to be increased.

Plot vertical base lines These vertical lines are drawn from the surface to the bottom of the base and are spaced the same as the X and Y mesh lines.

Base color Any integer from 1 to 15.

Text

This menu allows the user to specify textual information for the plot.

Select To Specify

PlotTitle a title and its placement and appearance.

AxisTitles border titles (axis titles) and their appearance.

EditText text blocks and their placement and appearance.

RetrieveText a file from which to retrieve text block information.

Legend a legend and its placement and appearance.

Title

Plot Title may be 0 to 79 characters (quotes are not needed).

Symbol set For help, select Symbols above number.

Title position Auto will center the title below the map. Alternatively, the user may specify the coordinates, in inches, of the lower left corner of the first character of the title. The title may also be positioned by pressing Alt-T while viewing the plot on the screen.

Angle is any value in degrees. The angle is measured counterclockwise from the +X axis. E.g. 0=horizontal, 90=vertical up.

Height is any positive value in inches. If too small, the title may not be readable. If too large, it may not fit on the plot.

Color is any integer from 1 to 15.

AxisTitles

Titles may be 0 to 79 characters (quotes are not needed). To remove the title, delete all characters with the Del key.

Symbol set For help, select Symbols from the help menu above number.

Height is any positive value in inches. If too small, the titles may not be readable. If too large, it may not fit on the plot.

Title-label distance Any number, in inches.

Color is any integer from 1 to 15.

EditText

The user may edit, create, or delete text blocks. To

create enter a current text block number greater than the largest existing text block number.

delete answer YES to the delete prompt.

edit another text block, enter a new value for current text block.

Symbol set For help, select Symbols from the help menu above number.

Height is any positive value in inches. If too small, the text may not be readable. If too large, it may not fit on the plot.

Color is any integer from 1 to 15.

Text position: Auto will place the text to the right of the plot. Alternatively, the user may specify the coordinates of lower left corner of the first character of the text. The text may also be positioned by pressing Alt-M while viewing the plot on the screen. If there is more than one text block on the screen, the text must be first captured by moving the crosshairs close to the lower left corner of the first character of the text, and pressing Alt-C. The text may also be sized (+ and -) and rotated (Alt-P for counterclockwise, Alt-N for clockwise rotation) on the screen.

To edit text: Move the cursor down to the desired line of text and begin text entry. To delete, use either Del or Back-Arrow. To insert, press Ins to toggle into insert mode, press it a second time to exit insert mode. (TypeOver is the default mode.) Use Home and End to go to the beginning or end of a line.

Special Keys: Certain Alt-Keys have special functions for text entry, (including titles). See Keys, page 2 for more help.

RetrieveText

You may specify the name of the input text file and what to do with existing text blocks.

Text file: The input text file must be a valid DOS filespec consisting of an optional drive, optional path, filename, and optional extension. If the extension is omitted, .TXT is used. If the path is omitted, the path (if any) specified by the DataPath option under Environ is used. The file is read when the popup menu is exited. The file must be in the format specified for .TXT files.

File read mode: If no text blocks currently exist, this option has no effect. If text blocks do exist, Append will read in the text blocks into the following empty blocks, shifting the index appropriately. DeleteFirst will delete all current text blocks before reading. OverWrite will modify any existing text blocks with the new information. For details, see the manual. If an attempt is made to read more text blocks than the maximum, those blocks will be ignored.

Legend

Plot orientation: Enter Yes to plot the orientation legend. The legend illustrates the rotation of the surface about the Z axis.

Legend position: Auto will center the legend near the lower right corner of the plot. Alternatively, the user may specify the coordinates in inches, of the lower left corner of the legend. The legend may also be positioned by pressing Alt-L while viewing the plot on the screen.

Legend Color: is any integer from 1 to 15.

AXES

The user may select to draw and label any or all of the X, Y, and Z axes. The axes and axis titles are plotted in the XY, XZ, or YZ plane.

Plot Axis: Enter Yes to plot the axis and optional tic marks and title.
Axis color: Integer from 1 to 15.
Axis symbol set: Character set for the labels. See Symbols above for help.
Axis plane: This is the plane in which the tic marks, tic mark labels, and axis title are drawn. The following table is used:

Axis	Auto	Normal	Flipped
	tilt < 10	tilt = 10	
X	XZ	XY	XY
Y	YZ	XY	YZ
Z	use Z and closest axis (X or Y)	reverse of Auto and Normal	

Tic distance: Spacing between tic marks in data units.

Labeled tic frequency: Auto will place labels so they do not overlap. Entry of 5, for example, will cause every 5th tic to be labeled.

Label format: Select Format above for help.

Label angle: Angle of labels relative to the axis in degrees. 0.0 will plot labels in same direction as axis. 90.0 will plot perpendicular.

Tic to label distance: Any number, in inches. This and other inch specifications below are relative to the projection used.

Label height: Positive number, in inches.

Size

The plot may be sized in two directions:

horizontally: The length of the plot base (X,Y) in inches may be specified. Either specify Length of longest side of base in inches, or, Number of data units per inch. The product of the two values is the length of the longest side in data units. Hence, only one of these may be specified. The shorter side is determined proportionally.

vertically: The plot may be exaggerated vertically by specifying the Z scale factor.

The current Z scale factor is given on the screen. Adjust this factor upwards or downwards to increase or decrease the vertical exaggeration. With Automatic, the Z scale factor is chosen to create a surface half as tall as the length of the diagonal across the XY plane.

The user may specify a conversion factor where the X and Y units differ. For example, if the Y units are yards and the X units are feet, the user can enter the value of 3.0 to specify that 1.0 Y units equal 3.0 X units.

XYLine

The boundary file is an ASCII file used for drawing line segments on the plot. The file may contain one or more series of connected lines, and is in the same format as the blanking files used in the GRID program.

No hidden line removal is done on the line segments. The lines are anchored to the surface only at the vertices specified in the file. Long segments will require intermediate points to closely follow the surface.

Each line is described by a set of vertices in the boundary file. The first row of the file has at least one value. This value is the number of points, N, specifying the line. The next N rows of the file contain the coordinates of these points, each row containing two values, an X and Y coordinate in data units.

Example

```
4 (0, 2) \
0 0 yields | \
1 5 0 the | \
0 2 triangle | \
0 0 (0, 0) \ (1.5, 0)
```

Post

This menu allows the user to specify posting information for the plot.

Select: To Specify

EditPost: posting blocks, including their creation and deletion. Selection of EditPost the first time will automatically create the first posting block.

RetrievePost: a file from which to retrieve posting block information.

EditPost

Post data points: Enter Yes to plot data points, indicated by a vertical line from the data point location on the surface to a label. No hidden line removal is performed on the labels or vertical lines.

Posting file: The posting file must be a valid DOS filespec consisting of an optional drive, optional path, filename, and optional extension. If the extension is omitted, .DAT is used. This ASCII file contains the data to be posted with an X coordinate, a Y coordinate, and a label.

X,Y and Label columns: These are the columns of the file containing the X and Y coordinates, and the label to be plotted at the X,Y coordinates.

Label format: Format to print labels in. Character format will print the labels exactly as they appear in the file. Select Format above for more help on numeric formats.

Number of digits: Used when Label format is set to a numeric format.

Label symbol set: For help, select Symbols from the help menu above.

Label height: The height of the posting label in inches.

Label angle: Angle of the label about its bottom left corner in degrees.

Label color: Integer from 1 to 15.

Relative position: Relative X,Y coordinates in inches, of the bottom left corner of the label as measured from the top of the vertical line. As an example, .5,1. will plot the bottom left corner of each label 0.5 inches to the right and 1.0 inches above the top of the vertical line from the data point.

Length of label line in inches: Length of the vertical line in inches, from the data point location on the surface to the label.

RetrievePost

You may specify the name of the input post file and what to do with existing post blocks

Post file The input post file must be a valid DOS filespec consisting of an optional drive, optional path, filename, and optional extension. If the extension is omitted, PST is used. If the path is omitted, the path (if any) specified by the DataPath option under Environ is used. The file is read when the popup menu is exited. The file must be in the format specified for PST files.

File read mode If no post blocks currently exist, this option has no effect. If post blocks do exist, Append will read in the post blocks into the following empty blocks, shifting the index appropriately. DeleteFirst will delete all current post blocks before reading. OverWrite will modify any existing post blocks with the new information. For details, see the manual. If an attempt is made to read more post blocks than the maximum, those blocks will be ignored.

Output

Create a plot file of the current surface plot. Optionally, send output to a printer or plotter via the PLOT program.

Name of plot file Specify the optional drive, optional path, filename, and optional extension of the plot file to create.

Scale factor Scale factor for the entire plot. For example, 2.0 will make the plot twice as big.

Page position Position of the entire plot in inches, from the bottom left corner. May be used to offset multiple plots when appending.

Plot file format ASCII may be read by any text editor. Binary is efficient.

File write mode Overwrite will cause the plot to be written over any old information in the file (hence destroying it). Append will write the current plot at the end of the specified plot file. If the plot file does not exist, a new one will be created.

Number of decimal Accuracy in decimal digits of values in the plot file. This digits in file value should reflect the resolution of the output device.

Send plot to Answer Yes to call program PLOT from within SURF. PLOT

installed device immediately begins plotting on the installed printer or plotter. Be sure to install PLOT first.

On-Screen Viewing

Select special function key F2 to plot the current contour map. Press any key except Esc to begin on screen digitization and editing. Move the crosshairs with the arrow keys. To change the movement step-size of the crosshairs, press any number from 1 (smallest step) to 9 (largest step).

To move the title, use the crosshairs and Alt-T. Only the last position of the title will be stored. The coordinates of the new title location will appear in the Title pop-up. Move the legend in the same way as the title, but use Alt-L in place of Alt-T.

On-Screen Text Block Positioning

To move a text block, first capture it using Alt-C. Place the crosshairs close to the lower left corner of the text block and press Alt-C. Then move the crosshairs to the new location and press Alt-M. The text block will be redrawn with the lower left corner at the crosshair location.

After a text block has been captured, the size may be increased by pressing +. Similarly, - will decrease its size. Alt-P will rotate positively (counter-clockwise) and Alt-N will rotate negatively. The rotation steps may be increased or decreased by pressing the numbers from 1 to 9 as for movement. 9 represents the largest rotation, of 90 degrees. 8 gives 45 degrees, 7 gives 22.5 degrees, and so forth.

The Titles and the Legend cannot be sized or rotated on the screen. The map title can be moved via Alt-T and the legend via Alt-L, but they cannot be captured via Alt-C.

Symbol sets

The following Symbol sets (fonts) are available. The sets may be altered using the ALTERSYM program.

DEFAULT.SYM Built in to SURF	SET10.SYM Triplex Roman
SET1.SYM Similar to default	SET11.SYM Triplex Italics
SET2.SYM Simplex Greek	SET12.SYM Old German
SET3.SYM Script	SET13.SYM Olde English
SET4.SYM Simplex Roman	SET14.SYM Old Italian
SET5.SYM Duplex Greek	SET15.SYM Special Symbols
SET6.SYM Simplex Italics	SET16.SYM Special Symbols
SET7.SYM Duplex Hershey	CENTERED.SYM Centered Symbols
SET8.SYM Duplex Script	
SET9.SYM Cyrillic	

For math symbols, use SET15 and SET16. The DEFAULT symbol set contains both centered symbols and a complete character set. Since this is built in to SURF, it does not need to be loaded and will plot faster. If a plot file is

to be created, CENTERED.SYM will be substituted for DEFAULT.SYM for the plotting centered symbol set.

Using the Help System

To obtain help relevant to the current topic press F1, the HELP key. To obtain further help, select any of the options at the top of this screen:

To select a Help option either type the first letter of the option or position the pointer with the arrow keys and press the Enter key.

To exit the help system and return to the SURF menus, press the Esc key.

Special keys

The following keys have special purposes:

F1	Help
F2	View current plot on screen
F3	Return to SURF Menu
F4	Save all current settings in a specified command file. Allows for saving text blocks in a TXT file and post blocks in a PST file.
Shift F4	Store highlighted setting in command file SURF.CMD
F5	Directory
Esc	Back up 1 level (Exits SURF as the SURF Menu)
Enter	Select current option; begin processing it on bottom row of pop-up.
Arrow keys	Move highlighted pointer
Home, End	Move to the beginning or end of a text line.

During text entry (in Title, AxisTitles, EditText), the following keys have special purposes:

Alt-U	Superscript. Any text that follows will plotted as a superscript.
Alt-D	Subscript. Any text that follows will plotted as a subscript.
Alt-N	Normalize. Undo a preceding superscript or subscript. Superscripts and subscripts may be nested. To go back to the normal size there must be as many Alt-N on that line as superscripts and subscripts.
Alt-B	Backspace one character, using the current size. (If it within a superscript, backspace using that size.)
Alt-F	Select a new font. Must be followed by a digit.
Alt-O	Select original font (the default font for this item).
Alt-P	Select a new color. Must be followed by one or two digits. If two digits follow Alt-P, both are used for the color number.
Alt-Q	Select original color.

Topic Menus

Two different types of menus are used to make choices. The first type appears on the upper two lines of the screen. This type of menu is used to rapidly select major topics and is called a topic menu. The menu at the top of this screen is a topic menu. Arrow keys may be used to move the highlighted pointer to different options. As different options are highlighted a brief explanation of the current option will be displayed on the second row of the screen.

After positioning the pointer to the desired option, it may be selected by pressing the Enter key. Options may be rapidly selected by typing the first letter of the desired option.

If Esc is pressed while in a topic menu, the previous menu will be displayed. Esc may be pressed until there are no more previous menus. In this case the program will end and return to DOS.

A second type of menu known as a pop-up menu will appear in various places in the lower portion of the screen. These menus are used to specify several related values at one time. The arrow keys will move the highlight from one field to another. To change an option simply type in the desired value and press Enter or the Up or Down arrow keys. Pressing the Enter key with the pointer on the bottom field will accept the current values and begin any related processing.

The Esc key may be pressed at any time to back up 1 level. If a string or value is being changed when Esc is pressed, the previous string or value will be restored. Pressing Esc a second time will exit the menu.

CmdLine

The format of the SURF command line is:

SURF [options] [Grid file]

where options can be any of the programmable SURF variables that appear in the SURF command file. Any variables that appear on the command line will override those in the command file. All options must be immediately preceded by a / or - character. Options must be separated with spaces or tabs. Strings containing blanks or tabs must be enclosed in double quotes. Type the SURF.CMD file for a complete list of valid options.

The last argument may be a file specification for a grid file in the format used by the GRID program. SURF will read the file and place the user at the Main Menu.

Example SURF /ANGH=270 /TITSTR = "THIS IS A TEST" TEST GRD

Format

Numeric values may be formatted in a Fixed, Exponential, or General format. With each of these methods, the user may specify the number of digits to the right of the decimal point. Internally all numeric values are stored as 32 bit entities. This is equivalent to approximately 7 digits of precision.

Fixed format is of the form [-]xxxx.xxxx where xxxx is one or more digits. The number of digits before the decimal point depends on the magnitude of the number.

Exponential format will print values with the form [-]x.xxxxE[sign]xxx, where x is a single digit, xxxx is one or more digits, and xxx is exactly three digits, and sign is + or -.

General format will print values in Fixed or Exponential format whichever is more compact for the given value and precision. Trailing zeros are truncated and the decimal point appears only if one or more digits follow it.

Environ

The Environ menus are used to configure SURF for the installed hardware. In most cases, SURF will make reasonable guesses as to the monitor type, colors, etc., but in some cases it may be desirable to override the default values.

ScreenType configures parameters related to the monitor such as the type of adapter, and whether to eliminate snow, use the BIOS, or write directly to the video buffer during display output. Viewing parameters may also be specified including the size of plot to fit on the screen and the plot origin.

Menu colors are set in the MenuColor menu, while plot colors are set in the ViewColor menu. Plot colors are used while viewing a plot on the EGA or VGA adapters.

The PlotDev menu configures the directory of the PLOT program, and invokes PLOT to allow a hardcopy output device to be configured.

Fonts specifies symbol sets, DataPath specifies the path for input and output files, and Units specifies English (inches) or metric (cm.) units.

Fonts

Enter the name of a symbol set (filename.SYM) for one or more of the fonts.

The internal symbol set, DEFAULT.SYM, is the normal default for rapid plotting. The names of these fonts will appear wherever symbol set numbers appear in popup menus.

DataPath

Enter a path for all input and output files (data files, grid files, level files, text block files, posting files, color zone files, etc. etc.). In other words, this path refers to those files referring to the users' data or which control the plotting of said data.

This path does not apply to SURF CMD, nor to symbol sets (fonts). Those are found in the same directory as SURF.EXE.

If no disk drive is specified, the currently active drive is used.

If the disk drive is specified with no directories, the currently active directory for that drive is used.

If the path specification is deleted or blanked, the currently active directory is used.

There are 3 paths of interest.

- 1 The path as specified under DataPath
- 2 The path used to activate SURF
- 3 The currently active directory

The last is used only if the first is blank or deleted.

PlotDev

The PLOT program is used to send the plot file created by SURF to a hardcopy output device. PLOT may be invoked at the DOS level, or from within SURF. If insufficient memory exists, PLOT will have to be invoked from DOS. In order for SURF to invoke the PLOT program, the drive, directory, and name of the PLOT program must be specified at the PLOT filespec prompt. Once this value is set, SURF will invoke PLOT in order to specify the desired output device. If just the name of the plot program is entered (PLOT.EXE), SURF will look first in the current directory, and then in all the directories specified in the current search path.

After PLOT is finished, you will be returned to SURF. At this point the PLOT filespec may be saved with the Shift-F4 key if desired. After saving the filespec, SURF will always invoke PLOT using this filespec until changed.

ScreenType

Use this menu to configure the display type and characteristics. In general, the default settings should be adequate and are best left alone. If it is necessary to change a setting, it may be saved with the Shift-F4 key.

Graphics adapter Use this option to specify the type of graphics adapter installed on the computer. The default setting of Auto will allow SURF to determine which adapter is installed. Care should be used when changing this option, since damage to the monitor may result from invalid settings.

Screen width This is the plot width in inches to display horizontally across the screen when viewing a plot. This does not have to be the physical width of the screen. As an example, if screen width is set to 2 inches, the entire screen will be used to plot a 2 inch portion of the plot starting at the current screen origin. This is similar to zooming in on a plot, more detail is shown, but portions of the plot will be off the screen.

Screen origin The screen origin is the X,Y coordinates in inches of the lower left corner of the screen. This is used to specify the position of a plot on the screen. When zooming in with the screen width option, the screen origin can be set to specify which portion of the plot to place on the screen.

Eliminate snow Snow consists of random flashes of light when the display is being written to. Usually, SURF will correctly determine whether snow elimination is necessary and automatically set this value. Snow elimination is usually only necessary on IBM color graphics cards (not EGA's), and will slow output considerably. This value is ignored if the BIOS is used.

BIOS SURF will usually write directly to the video buffer for performance reasons. On some compatibles or multitasking operating systems, this may cause problems. To use the ROM BIOS for all screen output, answer YES to this prompt. Note that this will slow all screen output.

MenuColor

This menu allows selection of the three colors used in all of SURF's menu screens. All possible colors are displayed on the popup, even though some of the colors may not be visible on monochrome monitors. To save the selected colors, use the Shift-F4 key to store the value in the command file.

ViewColor

Currently, the Enhanced Graphics Adapter is the only supported adapter with plotting colors. Since it is often desirable for the pen colors of a plotter to represent the same colors on the screen, this menu allows the pen numbers to be assigned to an EGA color value.

Blue 1 EGA color values are calculated by mixing the 6 base colors.
Green 2 from the table at left. The colors are mixed by adding in.
Red 4 the desired color's numeric code. For example, pure red has
Dark Blue 8 a color value of 4. High intensity white (a mixture of all
Dark Green 16 colors) is 1+2+4+8+16+32 = 63. Black is the absence of all
Dark Red 32 color, and has an EGA color value of 0. The brightest colors
are formed by a combination of the normal and dark colors.

For monochrome EGA's the only possible color values are 0,8, and 24. Even though 64 colors are possible, only 16 may be displayed at once on a 256K EGA, and only 4 colors at once on a 64K EGA. These limits are imposed by the EGA hardware.

Units

SURF may be configured to use centimeters instead of inches. Enter C or Centimeters at the prompt.

If Centimeters is selected, then wherever inches is asked for or assumed (for example, character heights, label-label distances, screen width among others) the value will be considered to be in centimeters. However, the popups do not change and will still read inches.

Also, the values given in the .PLT files will still be in terms of inches. In other words, the internal units in the SURFER package are inches, but the user may enter values in terms of centimeters.

The Legend text will be changed to read "1.0 cm = xx.xx data units".

TOPO Menu

TOPO is a menu-driven contouring program. The contour plot may be viewed on the screen, output to a plot file, and/or sent to a hardcopy device. Contour and plot parameters may be default values or fully specified by the user:

Gridded data, in the format used by the GRID program, is input from a data file in either ASCII or binary format. The fastest way to view a contour map on a graphics screen from DOS is to type the command

TOPO filename

and press function key F2. filename is any grid file produced by the GRID program, and may include an optional drive and path. If the extension is omitted, .GRD will be used. The contour plot will appear on the screen using default values for the contour and plot parameters. To modify the default values press Esc to return to the TOPO Menu.

Input Menu

You may specify the name of the input grid file and whether to input the entire file or a part of the file corresponding to a subgrid

Input grid file The input grid file must be a valid DOS filespec consisting of an optional drive, optional path, filename, and optional extension. If the extension is omitted, GRD is used. If the path is omitted, the path (if any) specified by the DataPath option under Environ is used. The file is read when the popup menu is exited.

First and last These options are used to specify a rectangular subgrid from rows and columns of the original grid file. Rows and columns are numbered starting with 1. The default values of 1 and 32767 will read the entire grid.

Level

The values of the contour lines may be changed by specifying the minimum, maximum, and interval values, or by specifying a data file containing the contour levels desired. The default values are chosen to give between 11 and 21 contours.

Minimum contour The lowest contour level to appear on the map.

Maximum contour The highest contour level to appear on the map.

Contour interval The interval or stepsize to use between the minimum and maximum contour levels. The total number of levels plotted will be $\text{int}((\text{Maximum} - \text{Minimum}) / \text{Interval})$. To omit all contour lines specify minimum and maximum contour levels that will exclude all Z values of the grid.

Level file The level file must be a valid DOS filespec consisting of an optional drive, optional path, filename, and optional extension. If the extension is omitted, .DAT is used. The level file is an ASCII data file with one contour level per line. There is a maximum of 200 levels if a level file is used. The levels do not need to be in any order, and do not need to be evenly spaced.

Scale

The user may specify the physical size of the plot by entering either of two parameters: the length in inches of the longest side of the plot, or the number of data units per inch.

TOPO will synchronize the two values whenever one is changed. Hence, if the length is given, the number of data units per inch is automatically determined. Conversely, if the number of data units per inch is specified, the length is recomputed. TOPO will automatically calculate the length of the shorter side of the map to maintain proportions.

This physical specification is for the data region only and does not include the extra space used for boundary labels, legend, text, and title.

The user may specify a conversion factor where the X and Y units differ. For example, if the Y units are yards and the X units are feet, the user can enter the value of 3.0 to specify that 1.0 Y units equal 3.0 X units.

ConLine (Contour Lines)

This menu allows the user to specify the contour line and in-line label parameters.

Select: To Specify

Labeled Labeled contour line frequency and the color, dash length, line thickness and hachure length of labeled contour lines.

Unlabeled Color, dash length, line thickness, and hachure length of unlabeled contour lines.

Conlab Properties of in-line contour labels, including the numeric format, color, height, and symbol set. The distance between labels, the distance from labels to edges, and the label curve tolerance may also be specified.

Smooth Whether to smooth contour lines, and how much.

ZonesOfColor A file which defines color zones. Each contour line within a color zone will use the color specified within this file.

Labeled Contour Lines

Frequency A frequency of 1 will label every contour line, 2 every other, and so on. Note that highly curved lines may not be labeled.

Color Integer from 1 to 15.

Dash length Length of the dashes and intervening spaces in inches. Enter zero for solid lines.

Thickness The thickness of the contour line in inches. Enter zero for normal lines.

Hachure length Length of the hachure marks in inches. These are the marks perpendicular to the contour lines which point in the direction of an enclosed data minimum, or depression. They are only marked on closed contour lines. The distance between adjacent hachure marks is twice their length.

< For Help on contour Labels, see the Help screen on Conlab >

Unlabeled Contour Lines

Color Integer from 1 to 15.

Dash length Length of the dashes and intervening spaces in inches. Enter zero for solid lines.

Thickness The thickness of the contour line in inches. Enter zero for normal lines.

Hachure length Length of the hachure marks in inches. These are the marks perpendicular to the contour lines which point in the direction of an enclosed data minimum, or depression. They are only marked on closed contour lines. The distance between adjacent hachure marks is twice their length.

In-line Contour Labels

Label format and digits For help, select Format from the help menu above.

Label height Any positive value, in inches.

Label color Integer from 1 to 15.

Symbol set number For help, select Symbols from the help menu above.

Curve tolerance Labels will not be placed on highly curved parts of a contour line, namely those where the distance along the contour line divided by the straight line distance is greater than the specified curve tolerance. Larger values allow labels on more highly curved parts.

Label to label distance Minimum distance between labels on the same contour line in inches. The actual distance may be much larger, subject to curve tolerance.

Label to edge distance Minimum distance between a label and the edge of the map in inches. The actual distance may be much larger, subject to curve tolerance.

Smooth

Smooth contour lines Enter Yes to smooth contour lines using cubic spline interpolation. This will result in a more pleasing appearance, but may cause contour lines to cross.

Tension factor Number greater than .001 and less than 60. The larger the number, the more the contour lines will approximate polygonal paths (paths made up of pieces of straight lines). The default value of 2.0 will generally give smooth curves.

ZonesOfColor

The user may specify a file containing information for color zones.

For example, if the file contains the following three lines

```
50 0 5      then color 5 is used if Z >= 50.0,
30 0 2      color 2 is used if 50.0 > Z >= 30.0,
10 0 1      color 1 is used if 30.0 > Z >= 10.0,
            and, the color is undefined if Z < 10.0
```

Hence, a contour of level Z = 40.0 will be plotted in color 2, as will a contour of level Z = 30.0.

The values in the file are sorted in increasing order of Z, so you may enter the lines in any order, but it is wise to enter them in either increasing or decreasing order to lessen the chance of a mistake.

With good color choices, considering the colors available on the output device a nice spectrum of colors may be created, with reds for highs, for example, and blues for lows.

Text

This menu allows the user to specify textual information for the plot.

Select To Specify

MapTitle a title, and its placement and appearance

BorderTitles border titles (axis titles), and their appearance

EditText text blocks and their placement and appearance

RetrieveText a file from which to retrieve text block information

Legend a legend and its placement and appearance

Title

The user may specify a title and its placement and appearance.

Map Title may be 0 to 79 characters (quotes are not needed)

Symbol set For help, select Symbols from the help menu above number

Title position Auto will center the title above the plot. Alternatively, the user may specify the coordinates of lower left corner of the first character of the title. The title may also be positioned by pressing Alt-T while viewing the plot on the screen.

Angle is any value in degrees. The angle is measured counterclockwise from the +X axis. E.g. 0=horizontal, 90= vertical up

Height is any positive value in inches. If too small, the title may not be readable. If too large, it may not fit on the plot.

Color is any integer from 1 to 15

BorderTitles

Titles may be 0 to 79 characters (quotes are not needed)

Symbol set For help, select Symbols from the help menu above number

Height is any positive value in inches. If too small, the titles may not be readable. If too large, it may not fit on the plot.

Color is any integer from 1 to 15.

EditText

The user may edit, create, or delete text blocks. To

create enter a current text block number greater than the largest extant text block number

delete answer YES to the delete prompt

edit another text block, enter a new value for current text block

Symbol set For help, select Symbols from the help menu above number

Height is any positive value in inches. If too small, the text may not be readable. If too large, it may not fit on the plot.

Color is any integer from 1 to 15

Text position Auto will place the text to the right of the plot. Or the user may specify the coordinates of lower left corner of the first character of the text. The text may also be positioned by pressing Alt-M while viewing the plot on the screen. If there is more than one text block on the screen, the text must be first captured by moving the crosshairs close to the lower left corner of the first character of the text, and pressing Alt-C. The text may also be sized (+ and -) and rotated (Alt-P for counterclockwise, Alt-N for clockwise rotation) on the screen.

To edit text Move the cursor down to the desired line of text and begin text entry. To delete, use either Del or Back-Arrow. To insert, press Ins to toggle into insert mode, press it a second time to exit insert mode. (TypeOver is the default mode.) Use Home and End to go to the beginning or end of a line.

Special Keys Certain Alt-Keys have special functions for text entry, (including titles). See Keys, page 2, for more help.

RetrieveText

You may specify the name of the input text file and what to do with existing text blocks.

Text file The input text file must be a valid DOS filename consisting of an optional drive, optional path, filename, and optional extension. If the extension is omitted, TXT is used. If the path is omitted, the path (if any) specified by the DataPath option under Environ is used. The file is read when the popup menu is exited. The file must be in the format specified for TXT files.

File read mode If no text blocks currently exist, this option has no effect. If text blocks do exist, Append will read in the text blocks into the following empty blocks, shifting the index appropriately. DeleteFirst will delete all current text blocks before reading. OverWrite will modify any existing text blocks with the new information. For details, see the manual. If an attempt is made to read more text blocks than the maximum, those blocks will be ignored.

Legend

Plot legend Enter Yes to plot the map legend. The legend illustrates the map scale graphically, by plotting a scale bar in inches and the current map scale. The map scale gives the number of data units per inch as a ratio, reading 1:X where X is the number of data units per inch.

Symbol set For help, select Symbols from the help menu above number

Units The user may specify alternate text to follow the number in "One inch = xx.xxx data units". For example, if "meters" is entered, the legend will read "One inch = xx.xxx meters".

Legend position Auto will center the legend below the plot. Alternatively, the user may specify the coordinates of lower left corner of the first character of the legend. The legend may also be positioned by pressing Alt-L while viewing the plot on the screen.

Height is any positive value in inches. If too small, the text may not be readable. If too large, it may not fit on the plot.

Color is any integer from 1 to 15

Border

Plot map border Answer Yes to plot a border box around the contour map.

Border color Integer from 1 to 15

Tic sides L = Left, R = Right, T = Top, B = Bottom

For no tics, delete all four and press Enter

X or Y..

Tic distance Use Auto to have TOPO select a grid distance, or enter a positive value in data units.

Labeled tic frequency Use Auto to have TOPO select a frequency based on label size, or enter a positive integer. 0 turns off labels.

Label angle 0 = horizontal, 90 = vertical. Other angles are not allowed.

Format and digits For help, select Format from the help menu above digits.

Character height Any positive value in inches.

Color Integer from 1 to 15.

Symbol set For help, select Symbols from the help menu above number

XYLine

The boundary file is an ASCII file used for drawing line segments on the plot. The file may contain one or more series of connected lines, and is in the same format as the blanking files used in the GRID program.

Each line is described by a set of vertices in the boundary file. The first row of the file has at least one value. This value is the number of points, N, specifying the line. The next N rows of the file contain the coordinates of these points, each row containing two values, an X and Y coordinate in data units.

```
Example
4          ( 0, 2) \
0 0  yields | \
1 5 0  the  | \
0 2  triangle | \
0 0          ( 0, 0) \ ( 1.5, 0)
```

Mesh

A mesh is a set of vertical and horizontal lines drawn across the plot as an aid in determining position.

Mesh color Integer from 1 to 15.

Dash length Length of the dashes and intervening spaces in inches. Enter 0.0 for solid lines. Note that if a large dash length is given, the mesh lines may appear solid, and if a small number is given, excessive time will be taken to draw the lines.

X spacing None will turn off the mesh lines. Auto will plot mesh lines at the border labels or the spacing of the input grid file.

Y spacing

The user may also enter a value in data units corresponding to the mesh spacing desired

Post

This menu allows the user to specify posting information for the plot:

Select: To Specify:

EditPost: posting blocks, including their creation and deletion
Selection of EditPost the first time will automatically create the first posting block.

RetrievePost a file from which to retrieve posting block information

EditPost

Current post block: Enter a new number to edit or create another post block

Delete this block: Enter "Y" or "YES" to delete this post block. To create a block, use Current post block.

Data file: The data file must be a valid DOS filespec consisting of an optional drive, optional path, filename, and optional extension. If the extension is omitted, .DAT is used. This ASCII file contains the data to be posted with an X and Y coordinate, an optional label and an optional symbol code on each line of the file.

X, Y, Label, Symbol & Angle columns: These are the columns of the file containing the X and Y coordinates, the optional label, the optional symbol code, and the optional angle. Enter 0 if the labels or symbols do not exist. As an example, 3,4,0 1 0 means that X, Y data is in columns 3 & 4, there is no Label nor Angle column, and column 1 contains the Symbols.

Include points outside grid: Enter Yes to plot all points in the file, or No to plot only those inside the grid limits.

Symbol code: Use this code if symbol codes are not in the file.

Symbol angle: Enter the angle of the symbol in degrees about its center, if angles are not read from the file.

Centered symbol set: For help, select Symbols from the help menu above. The internal symbol set, DEFAULT.SYM, includes centered symbols.

Symbol height: The height of the symbol in inches, or L or S where L = LinearProportional and S = SquareRootProportional. If either L or S is entered, then a second popup asks for these values. Proportional value column: Column from which to read the value used for creating proportional symbols. This may, but need not, be the same column as for Z values for contours.

Symbol height (GridMin, Value): Enter two symbol heights which will be the heights at the (GridMin, Value) specified values. If the proportional value column has (GridMax, Value) Z values (i.e. the same type of values as used for the contouring), then GridMin and GridMax may be used.

Symbol height (continued): If either Linear or SquareRoot proportional is chosen, then the symbol height will be interpolated.

Symbol color: Integer from 1 to 15.

Label format: Format to print labels in. Character format will print the labels exactly as they appear in the file. Select Format above for more help on numeric formats.

Number of digits: Used when Label format is set to a numeric format.

Label symbol set: For help, select Symbols from the help menu above.

Label height: The height of the posting label in inches.

Label angle: Angle of the label about its bottom left corner in degrees.

Label color: Integer from 1 to 15.

Relative position: Relative X, Y coordinates in inches of the bottom left corner of the label as measured from the data point position. The relative coordinates are added to the coordinates of the data point position to obtain the label position. Auto will center the label above the centered symbol position.

RetrievePost

You may specify the name of the input post file and what to do with existing post blocks.

Post file: The input post file must be a valid DOS filespec consisting of an optional drive, optional path, filename, and optional extension. If the extension is omitted, PST is used. If the path is omitted, the path (if any) specified by the DataPath option under Environ is used. The file is read when the popup menu is exited. The file must be in the format specified for .PST files.

File read mode: If no post blocks currently exist, this option has no effect. If post blocks do exist, Append will read in the post blocks into the following empty blocks, shifting the index appropriately. DeleteFirst will delete all current post blocks before reading.

OverWrite will modify any existing post blocks with the new information. For details see the manual. If an attempt is made to read more post blocks than the maximum, those blocks will be ignored.

Output

Create a plot file of the current contour map. Optionally send output to a printer or plotter via the PLOT program.

Name of plot file: Specify the optional drive, optional path, filename, and optional extension of the plot file to create.

Scale factor: Scale factor for the entire plot. For example, 2.0 will make the plot twice as big.

Page position: Position of the entire plot in inches, from the bottom left corner. May be used to offset multiple plots when appending.

Plot file format: ASCII may be read by any text editor. Binary is efficient.

File write mode: Overwrite will cause the plot to be written over any old information in the file (hence destroying it). Append will write the current plot at the end of the specified plot file. If the plot file does not exist, a new one will be created.

Number of decimal digits in the plot file: This digit value should reflect the resolution of the output device.

Send plot to installed device: Answer Yes to call program PLOT from within TOPO. PLOT immediately begins plotting on the installed printer or plotter. Be sure to install PLOT first.

On-Screen Contour Line Editing

Select special function key F2 to plot the current contour map. Press any key except Esc to begin on screen digitization and editing. Move the crosshairs with the arrow keys. To change the movement step-size of the crosshairs, press any number from 1 (smallest step) to 9 (largest step).

To edit the grid, select G. Use the direction keys to move the crosshairs. Note that the cursor is locked to grid element locations. Enter a new value to change the Z value at the current grid element. To save the new grid, use Alt-S. The old grid will be overwritten. Press Esc when done editing.

To move the title, use the crosshairs and Alt-T. Only the last position of the title will be stored. The coordinates of the new title location will appear in the Title pop-up. Move the legend in the same way as the title, but use Alt-L in place of Alt-T.

On-Screen Text Block Positioning

To move a text block, first capture it using Alt-C. Place the crosshairs close to the lower left corner of the text block and press Alt-C. Then move the crosshairs to the new location and press Alt-M. The text block will be redrawn with the lower left corner at the crosshair location.

After a text block has been captured, the size may be increased by pressing +. Similarly, - will decrease its size. Alt-P will rotate positively (counterclockwise) and Alt-N will rotate negatively. The rotation steps may be increased or decreased by pressing the numbers from 1 to 9 as for movement. 9 represents the largest rotation, of 90 degrees, 8 gives 45 degrees, 7 gives 22.5 degrees, and so forth.

The Titles and the Legend cannot be sized or rotated on the screen. The border titles cannot be moved at all. The map title can be moved via Alt-T and the legend via Alt-L, but they cannot be captured via Alt-C.

Symbol sets

The following Symbol sets (fonts) are available. The sets may be altered using the ALTERSYM program.

DEFAULT.SYM	Built in to TOPO	SET10.SYM	Triplex Roman
SET1.SYM	Similar to default	SET11.SYM	Triplex Italics
SET2.SYM	Simplex Greek	SET12.SYM	Old German
SET3.SYM	Script	SET13.SYM	Olde English
SET4.SYM	Simplex Roman	SET14.SYM	Old Italian
SET5.SYM	Duplex Greek	SET15.SYM	Special Symbols
SET6.SYM	Simplex Italics	SET16.SYM	Special Symbols
SET7.SYM	Duplex Hershey	CENTERED.SYM	Centered Symbols
SET8.SYM	Duplex Script		
SET9.SYM	Cyrillic		

For math symbols, use SET15 and SET16. The DEFAULT symbol set contains both centered symbols, and a complete character set. Since this is built in to TOPO, it does not need to be loaded and will plot faster. If a plot file is to be created, CENTERED.SYM will be substituted for DEFAULT.SYM for the posting centered symbol set. See also help for Fonts under Environ.

Using the Help System

To obtain help relevant to the current topic, press F1, the HELP key. To obtain further help, select any of the options at the top of this screen.

To select a Help option, either type the first letter of the option or position the pointer with the arrow keys and press the Enter key.

To exit the help system and return to the TOPO menus, press the Esc key.

Special Keys

The following keys have special purposes

F1 Help
F2 View current plot on screen
F3 Return to TOPO Menu
F4 Save all current settings in a specified command file
Allows for saving text blocks in a .TXT file and post blocks in a .PST file
Shift-F4 Store highlighted setting in command file TOPO CMD
F5 Directory
Esc Back up 1 level (Exit TOPO at the TOPO Menu)
Enter Select current option; begin processing it on bottom row of pop-up
Arrow keys Move highlighted pointer
Home, End Move to the beginning or end of a text line

During text entry (in Title, BorderTitles, EditText) the following keys have special purposes

Alt-U Superscript. Any text that follows will plotted as a superscript
Alt-D Subscript. Any text that follows will plotted as a subscript
Alt-N Normalize. Undo a preceding superscript or subscript.
Superscripts and subscripts may be nested. To go back to the normal size, there must be as many Alt-N on that line as superscripts and subscripts
Alt-B Backspace one character, using the current size. (i.e. if within a superscript, backspace using that size.)
Alt-F Select a new font. Must be followed by a digit
Alt-O Select original font (the default font for this item)
Alt-P Select a new color. Must be followed by one or two digits.
If two digits follow Alt-P, both are used for the color number
Alt-Q Select original color.

Topic Menus

Two different types of menus are used to make choices. The first type appears on the upper two lines of the screen. This type of menu is used to rapidly select major topics and is called a topic menu. The menu at the top of this screen is a topic menu. Arrow keys may be used to move the highlighted pointer to different options. As different options are highlighted a brief explanation of the current option will be displayed on the second row of the screen.

After positioning the pointer to the desired option, it may be selected by pressing the Enter key. Options may be rapidly selected by typing the first letter of the desired option.

If Esc is pressed while in a topic menu, the previous menu will be displayed. Esc may be pressed until there are no more previous menus. In this case the program will end and return to DOS.

< For more help on menus, select Next from the help menu above >

A second type of menu known as a pop-up menu will appear in various places in the lower portion of the screen. These menus are used to specify several related values at one time. The arrow keys will move the highlight from one field to another. To change an option simply type in the desired value and press Enter or the Up or Down arrow keys. Pressing the Enter key with the pointer on the bottom field will accept the current values and begin any related processing.

The Esc key may be pressed at any time to back up 1 level. If a string or value is being changed when Esc is pressed, the previous string or value will be restored. Pressing Esc a second time will exit the menu.

< For more help on menus, select Prev from the help menu above >

CmdLine

The format of the TOPO command line is:

TOPO [options] [Grid file]

where options can be any of the programmable TOPO variables that appear in the TOPO command file. Any variables that appear on the command line will override those in the command file. All options must be immediately preceded by a / or - character. Options must be separated with spaces or tabs. Strings containing blanks or tabs must be enclosed in double quotes. Type the TOPO CMD file for a complete list of valid options.

The last argument may be a file specification for a grid file in the format used by the GRID program. TOPO will read the file and place the user at the TOPO Menu.

Example TOPO /CINT = .10 /TTSTR = "THIS IS A TEST" TEST.GRD

Format

Numeric values may be formatted in a Fixed, Exponential, or General format. With each of these methods, the user may specify the number of digits to the right of the decimal point. Internally all numeric values are stored as

32 bit entities. This is equivalent to approximately 7 digits of precision.

Fixed format is of the form [-]xxxx.xxxx where xxxx is one or more digits. The number of digits before the decimal point depends on the magnitude of the number.

Exponential format will print values with the form [-]x.xxxxE[sign]xxxx where x is a single digit, xxxx is one or more digits, and xxx is exactly three digits, and sign is + or -.

General format will print values in Fixed or Exponential format whichever is more compact for the given value and precision. Trailing zeros are truncated and the decimal point appears only if one or more digits follow it.

Environ

The Environ menus are used to configure TOPO for the installed hardware. In most cases TOPO will make reasonable guesses as to the monitor type, colors, etc., but in some cases it may be desirable to override the default values.

ScreenType configures parameters related to the monitor such as the type of adapter, and whether to eliminate snow, use the BIOS, or write directly to the video buffer during display output. Viewing parameters may also be specified including the size of plot to fit on the screen and the plot origin.

Menu colors are set in the MenuColor menu, while plot colors are set in the ViewColor menu. Plot colors are used while viewing a plot on the EGA or VGA adapters.

The PlotDev menu configures the directory of the PLOT program, and invokes PLOT to allow a hardcopy output device to be configured.

Fonts specifies symbol sets. DataPath specifies the path for input and output files, and Units specifies English (inches) or metric (cm) units.

Fonts

Enter the name of a symbol set (filename SYM) for one or more of the fonts.

The internal symbol set DEFAULT.SYM, is the normal default for rapid plotting. The names of these fonts will appear wherever symbol set numbers appear in popup menus.

DataPath

Enter a path for all input and output files (data files, grid files, level files, text block files, posting files, color zone files, etc. etc.) In other words, this path refers to those files referring to the users' data or which control the plotting of said data.

This path does not apply to TOPO CMD, nor to symbol sets (fonts). Those are found in the same directory as TOPO EXE.

If no disk drive is specified, the currently active drive is used. If the disk drive is specified with no directories, the currently active directory for that drive is used. If the path specification is deleted or blanked, the currently active directory is used.

There are 3 paths of interest:
1. The path as specified under DataPath
2. The path used to activate TOPO
3. The currently active directory.

The last is used only if the first is blank or deleted.

PlotDev

The PLOT program is used to send the plot file created by TOPO to a hardcopy output device. PLOT may be invoked at the DOS level, or from within TOPO. If insufficient memory exists, PLOT will have to be invoked from DOS. In order for TOPO to invoke the PLOT program, the drive, directory, and name of the PLOT program must be specified at the PLOT filespec prompt. Once this value is set, TOPO will invoke PLOT in order to specify the desired output device. If just the name of the plot program is entered (PLOT EXE), TOPO will look first in the current directory, and then in all the directories specified in the current search path.

After PLOT is finished, you will be returned to TOPO. At this point the PLOT filespec may be saved with the Shift-F4 key if desired. After saving the filespec, TOPO will always invoke PLOT using this filespec until changed.

ScreenType

Use this menu to configure the display type and characteristics. In general, the default settings should be adequate and are best left alone. If it is necessary to change a setting, it may be saved with the Shift-F4 key.

Graphics adapter Use this option to specify the type of graphics adapter installed on the computer. The default setting of Auto will allow TOPO to determine which adapter is installed. Care should be used when changing this option, since damage to the monitor may result from invalid settings.

Screen width This is the plot width in inches to display horizontally across the screen when viewing a plot. This does not have to be the physical width of the screen. As an example, if screen width is set to 2 inches, the entire screen will be used to plot a 2 inch portion of the plot starting at the current screen origin. This is similar to zooming in on a plot: more detail is shown, but portions of the plot will be off the screen.

Screen origin The screen origin is the X,Y coordinates in inches of the lower left corner of the screen. This is used to specify the position of a plot on the screen. When zooming in with the screen width option, the screen origin can be set to specify which portion of the plot to place on the screen.

Eliminate snow Snow consists of random flashes of light when the display is being written to. Usually, TOPO will correctly determine whether snow elimination is necessary and automatically set this value. Snow elimination is usually only necessary on IBM color graphics cards (not EGA's), and will slow output considerably. This value is ignored if the BIOS is used.

BIOS TOPO will usually write directly to the video buffer for performance reasons. On some compatibles or multitasking operating systems, this may cause problems. To use the ROM BIOS for all screen output answer YES to this prompt. Note that this will slow all screen output.

MenuColor

This menu allows selection of the three colors used in all of TOPO's menu screens. All possible colors are displayed on the popup, even though some of the colors may not be visible on monochrome monitors. To save the selected colors, use the Shift-F4 key to store the value in the command file.

ViewColor

Currently, the Enhanced Graphics Adapter is the only supported adapter with plotting colors. Since it is often desirable for the pen colors of a plotter to represent the same colors on the screen, this menu allows the pen numbers to be assigned to an EGA color value.

Blue	1	EGA color values are calculated by mixing the 6 base colors
Green	2	from the table at left. The colors are mixed by adding in
Red	4	the desired color's numeric code. For example, pure red has
Dark Blue	8	a color value of 4. High intensity white (a mixture of all
Dark Green	16	colors) is $1+2+4+8+16+32 = 63$. Black is the absence of all
Dark Red	32	color, and has an EGA color value of 0. The brightest colors

are formed by a combination of the normal and dark colors.

For monochrome EGA's the only possible color values are 0,8, and 24. Even though 64 colors are possible, only 16 may be displayed at once on a 256K EGA, and only 4 colors at once on a 64K EGA. These limits are imposed by the EGA hardware.

Units

TOPO may be configured to use centimeters instead of inches. Enter C or Centimeters at the prompt.

If Centimeters is selected, then wherever inches is asked for or assumed (for example, character heights, label-label distances, screen width among others) the value will be considered to be in centimeters. However, the popups do not change and will still read inches.

Also, the values given in the .PLT files will still be in terms of inches. In other words, the internal units in the SURFER package are inches, but the user may enter values in terms of centimeters.

The Legend text will be changed to read "1.0 cm = xx.xx data units"

UTIL MENU

UTIL is a utility program which performs several functions on grid files such as produced by the GRID program in the SURFER package

From the UTIL Menu select

Volume to calculate volumes of solids defined by gridded surfaces
Slice to create cross-sections of a gridded surface for either a boundary file for SURFER or a data file for GRAPHER
Residuals to calculate the residuals of a set of data from a gridded surface
Convert to convert a grid file to a data file, or between grid formats
Area-of-a-Surface to calculate the surface area of a gridded surface
Environ to specify the hardware configuration

To learn more about the help system select the desired topic above with the arrow keys and press Enter. Press the Esc key to exit the help system and return to UTIL.

Volume Menu

The Volume menu contains all options related to computing volumes of solids between gridded surfaces (.GRD files as created by GRID)

First, specify the Upper surface, which is usually a grid file (.GRD file created by GRID). The LOWER surface is usually a constant (the default is Z=0). However, either surface may be a grid file or a constant. Select either Upper or Lower to specify these surfaces

Volume computes the net volume between the surfaces. Net volume is the volume (as in Calculus) as computed by a double integral, and is the difference between positive volume (where the "Upper" surface is above the "Lower" surface) and negative volume (where the reverse is true)

Cuts&Fills also computes net volume, but in addition computes separately positive volume (Cuts) and negative volume (Fills). Cuts is that volume where the upper surface is above the lower. Fills is where the lower surface is above the upper.

For Cuts&Fills one may consider the Upper surface to be the original surface and the Lower surface to be the new surface. Then the Cuts volume is the volume of material removed and the Fills volume is the volume of material added in shaping the original surface to be the new surface for example, in road construction or in land resnapping

Cuts&Fills also computes + Area and - Area. The former is the area of the region over which the Upper surface is above the Lower surface while the latter is the area of the region over which the Lower surface is above the Upper surface. Where the two surfaces are exactly equal, that area is included in + Area.

If the lower surface is a constant (Z = constant), then + Area is the area within all contours specified by that constant. Total area is the sum of the two areas and should equal the area of the gridded region

Notes on blanked grids: If either the upper surface or the lower surface or both is blanked at a grid location, then the thickness of the solid is considered to be zero at that location. This may introduce errors for the volume calculations. The use of a denser grid may compensate for these errors. The area of any blanked areas is included in the +Area total.

Volume methods: Three methods are used to compute net volume: Trapezoidal Rule, Simpson's Rule, and Simpson's 3/8 Rule. The first two are found in nearly every Calculus text under "Numerical Integration" or "Numerical Quadrature". The methods are applied to the volume integral considered as an iterated integral, with computations performed first in the X direction and then in the Y direction. The latter two methods require a certain number of intervals. For example, Simpson's Rule requires an odd number of grid lines in each direction. If an even number of grid lines is given in the grid file, then Simpson's Rule will be used in all but the last interval, in which the Trapezoidal Rule is used. Hence, as needed, the next best method is used to finish out the calculations.

For an estimate of the errors, you may compare the results from the three methods.

If the Upper surface is always above the Lower surface, then the results should usually agree to at least five or six decimal places

However, if the Upper surface is not always above the Lower surface, then it may happen that the results are less significant, especially when the results are close to zero. In this case, you should also look at the Cuts&Fills volumes to get an idea of the relative error.

The difference between Cuts and Fills volumes is usually quite close to the result from the Trapezoidal Method

Warning: The results depend on the gridded surfaces given. If your gridded surface was obtained from only a handful of data-points, or from noisy data, the results may be almost totally meaningless!

LogResults allows you to direct the results to a file - quite useful for batch

Upper

The Upper menu is used to specify the upper surface for volume computation. The surface may be specified by a File, namely a grid file (.GRD) as created by the GRID program, or by a Constant level. The default is a grid file. Answer the first question with F or File to select a file, and with C or Constant to select a constant.

If File is selected, the default is to use the entire grid. If a subgrid is desired, you must calculate the columns (X direction) and rows (Y direction) needed to specify the region that you want, and enter those values. After computing a volume, check the X and Y limits of the subregion to see if they are correct. Note that columns and rows of 1 to 32767 will read the entire grid.

If a constant level is selected, enter a number. The volume will be computed between this level and the other surface.

Lower

The Lower menu is used to specify the lower surface for volume computation.

The surface may be specified by a File, namely a grid file (.GRD) as created by the GRID program, or by a Constant level. The default is a constant. Answer the first question with F or File to select a file, and with C or Constant to select a constant.

If File is selected, the default is to use the entire grid. If a subgrid is desired, you must calculate the columns (X direction) and rows (Y direction) needed to specify the region that you want, and enter those values. After computing a volume, check the X and Y limits of the subregion to see if they are correct. Note that columns and rows of 1 to 32767 will read the entire grid.

If a constant level is selected, enter a number. The volume will be computed between this level and the other surface.

If the area within a contour level is desired, give the contour level for the lower surface and give the grid file for the upper surface. Then the positive area (+ Area) is the area within and at that contour.

ResultsLog

The ResultsLog option allows you to specify a log file for your results. This is also necessary for batch operation.

Enter a file name so that subsequent results will be placed into the specified log file. Delete the file name to discontinue logging of results.

Enter Overwrite to delete a log file of the same name, and use that name for subsequent results. Enter Append to append the subsequent results to this log file, and not delete any results currently in the file. (If the file was not an ASCII file, however, then the file contents may be destroyed.)

Overwrite is only used for the first computation, after which it is automatically changed to Append. This feature was designed for batch operation.

The file is closed after each Volume or Cuts&Fills operation.

The log file for volume computations has no connection with the other log files in UTIL, unless you specify the same log file for all operations.

Slice

Slice will, if given a file in the Boundary Line Format (see the GRID manual) containing lines through the region specified by a grid file (.GRD file as produced by GRID), produce either or both of

a new boundary line file (.BLN file) with points inserted for every grid line crossing. This may be used for example, with SURF to plot roads, rivers, or other line features on three-dimensional surfaces. The file contains the X, Y, Z data to plot these lines. No points are inserted outside the grid region or over blanked areas of the grid.

a data file (.DAT file) which contains X, Y, Z data in columns 1, 2, 3 and horizontally traversed distance in column 4. Column 5 contains an integer which specifies from which original line the data was computed.

Regardless of which file is produced, if any, the screen will give summary results of the computations, such as how many points were generated.

The clip value may be used in GRAPHER. If an input boundary line leaves the grid region and if the question "Outside grid, use clip value?" was answered "Y" or "Yes", then a single X, Y, Z point will be inserted into the data file, with Z equal to the clip value, for each input boundary line vertex which is outside the grid region. Then in GRAPHER these points may be clipped from the plots by using a lower clipping value between the Slice clip value and the grid file minimum Z value.

For example, if the third column of the data file, namely the Z values, is plotted against the fourth column, the horizontal traverse distance, then a

clip value can be specified in GRAPHER. The clip value should be at least as large as the Slice clip value and no more than the grid file minimum Z. Whenever the input boundary line leaves the region, Grapher will clip it.

If the question "Over blank area, use clip value" is answered with "Y" or "Yes", then whenever an input boundary line traverses a grid line where one or both of the closest grid points is blanked, then similarly an X, Y, Z point will be inserted into the data file with Z equal to the clip value.

Residuals

Residuals will, if given a gridded surface (as specified by a .GRD file as produced by GRID) and a data file (which need not be the file used to produce the gridded surface), optionally produce a new data file of residuals from the surface and will give the mean and standard deviation of these residuals.

Optionally, a summary of results, including the mean and standard deviation of the residuals, will be written to a log file. This file may, but need not be, the same as the other log files in UTIL.

The residuals (X, Y, Z data points) are only computed for input data points which are found within the grid region and over non-blanked areas. Since the surface is computed, not over rectangular cells but over subtriangles (lower left and upper right) of the rectangular cells, residuals are only computed if the data point is located within a triangle which has all three vertices unblanked. (Note to new users: if you have never used blanking in SURFER, you may safely ignore this discussion.)

Input Data Columns may be specified, if other than the usual 1,2,3 for X, Y, Z. However, if columns are specified which cannot be found in the input data file, then the output data file will be empty. No warning is given.

You may send summary results to a log file. This may be useful for batch operation. To keep a log file, enter a file name in response to "Output log file [LOG]" so that subsequent results will be placed into the specified log file. Delete the file name to discontinue logging of results.

Enter Overwrite to delete a log file of the same name and use that name for subsequent results. Enter Append to append the subsequent results to this log file, and not delete any results currently in the file. (If the file was not an ASCII file, however, then the file contents may be destroyed.)

Overwrite is only used for the first computation, after which it is automatically changed to Append. This feature was designed for batch operation.

Output Format may be specified. The default format is G6 G6 G6 (Note: no quotes!)

The supported specifications are:

- G6 = print 6 digits after the decimal point, using either E or f formats below, whichever is more compact.
- E6 = print 6 digits after the decimal point, one digit before the decimal point, in the scientific format [-]d dddd[E]signddd. The sign of the exponent is always printed.
- f6 = print 6 digits after the decimal point, and as many before the decimal point as are needed. If no more than 8 characters are printed before the decimal point (8 digits, or minus sign plus 7 digits), then the results will appear columnated with the decimal points in the same column.

In these examples, the number 6 may be changed to any number from 0 to 9. However, single precision computations imply about 7 significant digits. Any other characters may be used, and are printed on each output line.

Convert

Convert can be used to

convert a grid file (.GRD, as produced by the GRID program) to an X, Y, Z data file

convert a grid file to a different format (binary to ASCII or ASCII to binary)

In doing either type of conversion, a subgrid of the input grid may be selected. To do so, enter the desired rows and columns of the subgrid. Otherwise, leave the rows and columns unchanged (1-32767).

Note that if a grid file has blanking values, that conversion to a data file will insert these blanking values into the data file as if they were actual data points. If required, they should be removed using a text editor.

Area-of-a-Surface

This option can be used to

Compute the approximate Surface Area of a gridded surface.

To obtain the entire Surface Area of the gridded surface, either enter a Constant Level which is below (or above) the entire surface. Then the result will be the Surface Area of the entire surface.

To obtain the Surface Area of that part of the surface which lies above (below) a specified z-value, set Constant Level to that value. The result will also include that part of the surface AT the Constant Level in the case of "above".

To log results to a file (necessary for batch operations), enter a filename for the log file. If no log file is desired, delete completely any entry given for the log file. The results are always appended to the log file.

If any corner of a grid cell is blanked, all or half of that grid cell will not be included in the computations. The areas computed as part of Cuts&Fills calculations include blanked areas.

GridIO

Grid files may be written in one of two formats, Binary or ASCII. Binary is much faster and creates smaller files. However, Binary files cannot be typed, edited, or imported into programs other than those by Golden Software. Because of these limitations, files may be output as ordinary ASCII text files. These files may then be imported into editors and other programs for further processing or modification.

During input, it is possible to specify a sub-grid within the grid file. The questions pertaining to first and last rows and columns refer to the limits of the sub-grid to read. UTIL will extract only those rows and columns from the grid file that comprise the specified sub-grid. The default range of 1 to 32767 will read the entire grid.

Using the Help System

To obtain help relevant to the current topic, press F1, the HELP key. To obtain further help, select any of the options at the top of this screen.

To select a Help option, either type the first letter of the option or position the pointer with the arrow keys and press the Enter key.

To exit the help system and return to the UTIL menu, press the Esc key.

Special keys

The following keys have special purposes:

- F1 Help
- F3 Return to UTIL Menu
- F4 Save all current settings in a specified command file
- Shift F4 Store highlighted setting in command file UTIL.CMD
- F5 Directory
- Esc Back up 1 level (EXITS UTIL at UTIL Menu)
- Enter Select current option; begin processing if on bottom row of pop-up
- Arrow keys Move highlighted pointer

Topic Menus

Two different types of menus are used to make choices. The first type appears on the upper two lines of the screen. This type of menu is used to rapidly select major topics and is called a topic menu. The menu at the top of this screen is a topic menu. Arrow keys may be used to move the highlighted pointer to different options. As different options are highlighted, a brief explanation of the current option will be displayed on the second row of the screen.

After positioning the pointer to the desired option, it may be selected by pressing the Enter key. Options may be rapidly selected by typing the first letter of the desired option.

If Esc is pressed while in a topic menu, the previous menu will be displayed. Esc may be pressed until there are no more previous menus. In this case, the program will end and return to DOS.

A second type of menu known as a pop-up menu will appear in various places in the lower portion of the screen. These menus are used to specify several related values at one time. The arrow keys will move the highlight from one field to another. To change an option, simply type in the desired value and press Enter or the Up or Down arrow keys. Pressing the Enter key with the pointer on the bottom field will accept the current values and begin any related processing.

The Esc key may be pressed at any time to back up 1 level. If a string or value is being changed when Esc is pressed, the previous string or value will be restored. Pressing Esc a second time will exit the menu.

CmdLine

The format of the UTIL command line is:

UTIL [options]

where options can be any of the programmable UTIL variables that appear in the UTIL command file. Any variables that appear on the command line will override those in the command file. All options must be immediately preceded by a / or - character. Options must be separated with spaces or tabs. Strings containing blanks or tabs must be enclosed in double quotes. Type the UTIL.CMD file for a complete list of valid options.

Example UTIL /JGNAME=NOW1.GRD

Format

Numeric values may be formatted in a Fixed, Exponential, or General format. With each of these methods, the user may specify the number of digits to the right of the decimal point. Internally all numeric values are stored as 32 bit entities. This is equivalent to approximately 7 digits of precision.

Fixed format is of the form [-]xxxx.xxxx where xxx is one or more digits. The number of digits before the decimal point depends on the magnitude of the number.

Exponential format will print values with the form [-]x.xxxxE[sign]xxx where x is a single digit, xxx is one or more digits, and xxx is exactly three digits and sign is + or -.

General format will print values in Fixed or Exponential format, whichever is more compact for the given value and precision. Trailing zeros are truncated and the decimal point appears only if one or more digits follow it.

Environ

The Environ menus are used to configure UTIL for the installed hardware. In most cases, UTIL will make reasonable guesses as to the monitor type, colors, etc., but in some cases it may be desirable to override the default values. DataPath specifies the path for input and output files.

ScreenType is used to specify display output parameters. The first is whether to eliminate snow or not. Snow consists of random flashes of light when the display is being written to. Snow elimination is usually only necessary on IBM color graphics cards (not EGA's), and will slow output considerably. This value is ignored if the ROM BIOS is used.

On some compatibles or multitasking operating systems it is necessary to use the ROM BIOS for display output. To use the ROM BIOS for all screen output answer YES to the BIOS prompt in the ScreenType popup. Note that this will slow all screen output.

The MenuColor menu allows selection of the three colors used in all of UTIL's menu screens. All possible colors are displayed on the popup, even though some of the colors may not be visible on monochrome monitors. To save the selected colors, use the Shift-F4 key to store the value in the command file.

DataPath

Enter a path for all input and output files (data files, grid files, etc.). In other words, this path refers to those files referring to the users' data or which control the gridding of said data.

This path does not apply to UTIL.CMD. That is found in the same directory as UTIL.EXE.

If no disk drive is specified, the currently active drive is used.

If the disk drive is specified with no directories, the currently active directory for that drive is used.

If the path specification is deleted or blanked, the currently active directory is used.

There are 3 paths of interest:

1. The path as specified under DataPath.
2. The path used to activate UTIL.
3. The currently active directory.

The last is used only if the first is blank or deleted.

ALTERSYM is a menu-driven symbol editor

ALTERSYM allows you to

- Input symbols from a file.
- Edit (alter) symbols on a graphics screen (using cursor arrow keys)
- Copy symbols to other locations within the symbol set
- Delete symbols.
- Extract (Xtract) symbols from other symbol sets
- Save symbols to a file.
- View all symbols on the graphics screen, and
- Optimize symbols for plotting speed and smaller file size

The input symbol file name may also be specified on the DOS command line as ALTERSYM filename

The symbol set may be viewed by pressing function key F2 filename is any symbol file produced by ALTERSYM or included with Golden Software products (symbol files have the extension SYM) The extension (SYM) is optional.

Input Menu

You may specify the name of the input symbol file

Input symbol set The input symbol file must be a valid DOS filespec consisting of an optional drive, optional path, filename, and optional extension

If the extension is omitted, SYM is used

If the path is omitted, the path (if any) specified by the DataPath option under Environ is used

The file is read when the popup menu is exited by hitting <Enter>

Warning Any current symbols will be deleted

Alter

Specify the number (from 32 to 127) of the symbol to edit or create

After pressing <Enter>, the graphics screen will appear, and you may edit or create the symbol using the commands listed at the bottom of the graphics screen Use the cursor arrow keys to move the cross-hairs

Symbols are stored as a list of records. Each record has the X,Y location of a point, and, a command The command is either a MOVE or a DRAW A MOVE is a pen-up move to the point A DRAW is a pen-down move to the point from the previous point in the list (hence a line would be drawn from the previous point to the current point) A symbol consists of one or more chains of points, the first point in each chain having a MOVE command, the rest having DRAW commands.

The commands are:

- + Draw and edit the next character. (= may be used instead of +)
- Draw and edit the previous character.
- <Esc> Escape back to the main menu

- S Start Start drawing a chain at the current cross-hairs location (A record is appended to the list with the MOVE command)
- D Draw Draw a line from the last point in the list to this point. (A record is appended to the list with the DRAW command)
- R Remove Remove the point at the cross-hairs from the list of points. (The last record matching this X,Y location is removed from the list. If there are more than one records for this location, only the last is removed.)
- T Toggle Toggle the status of the point at the cross-hairs (The last record matching this X,Y location has its MOVE/DRAW status changed to the other status If the former status was MOVE, this will link the previous chain to this one If the former status was DRAW, this will split the chain)
- M Move Move the point at the cross-hairs. This is a 2-step command Position the cross-hairs at a point. Press M Position the cross-hairs at a new point. Press M again Only the last point in the record list which has the first cross-hair location will be moved.

- I Insert Capture and cut a line and insert a new point between the endpoints. This is a 2-step command Position the cross-hairs near the desired line and press I The captured line will change color and be dashed If the wrong line was captured, press any key but I and try again. Then move the cross-hairs

to the new location and enter I The old line will be erased, and two new lines will be drawn from the old endpoints to the new point

- W Width Define the width of the symbol This need not be the plotted width of the symbol The left and right values are used to position symbols when several are plotted in a text string such as a title If the width is smaller than the plotted symbol then adjacent symbols may overlap If the width is much larger than the plotted symbol then there may be large gaps between adjacent symbols If the width is the same for every symbol in a symbol set then the set has fixed spacing If the width is appropriate to the plotted width of each symbol, then the set has proportional spacing

- Q Toggle printing of records

- Q Toggle printing of records The default is to not print any records However if record printing is enabled, then when the cross-hairs are over a point in the record list, the corresponding records will be printed on the right side of the screen This may be useful on occasion but is a very slow option

Problems?

Missing points missing lines, nonexistent lines? It doesn't look right?

During an editing session, especially when many points and lines have been created and deleted, artifacts may be left on the screen which are not part of the character. To save time, the character is not redrawn after every change, hence to obtain the true screen image of the character it is necessary to exit the editing session, and then re-edit (Alter) the character.

Copy

The user may copy a symbol to another location

Warning: If a symbol already exists at the destination it will be deleted

This option is useful, for example, when similar symbols must be created such as for an international character set. One symbol is created first, then copies are made and accent marks may be added to the copies

Delete

The user may delete a symbol Note that a Delete cannot be undone

Sometimes in editing a symbol set, the user may delete all the points and lines of a symbol, and the symbol appears in the symbol table as having zero records. If that is not desired, this option may be used to delete the symbol

(Sometimes a blank record may be useful, to take up space in text for example, as it will be plotted as a blank Hence, blanks of different lengths may be created)

Xtract

The user may extract a symbol from another symbol set.

Warning: If a symbol already exists at the destination, it will be deleted

The specified symbol will be copied from the specified symbol set and placed into the new location

Save

The user may save the results of a symbol edit session to a symbol file

Output symbol set The output symbol file must be a valid DOS filespec consisting of an optional drive, optional path, filename, and optional extension.

If the extension is omitted, .SYM is used.

If the path is omitted, the path (if any) specified by the DataPath option under Environ is used.

The file is written when the popup menu is exited by hitting <Enter>.

Optimize

The user may optimize the entire symbol set or one specified symbol

This operation will attempt to join disconnected segments For example, the capital letter A may be drawn as three separate segments Optimize will connect the two slanted segments into one chain as shown. This minimizes the

vertical and horizontal pen motion of a plotter, as well as decreasing the size of the symbol file.

```

      2 5      Move to 1      2      Move to 1
      #       Draw to 2      #       Draw to 2
      ##      Move to 3      ##      Draw to 3
      # #     Draw to 4      # #     Move to 4
      # #     Move to 5      # #     Draw to 5
      # #     Draw to 6      # #
3 ##### 4          4 ##### 5
# #              # #
# #              # #
# #              # #
# 1              # 6      # 1      # 3

```

View

The user may view the symbol set, 32 symbols at a time, on the graphics screen. Note that the function key <F2> and the menu selection View have the same function.

Use the + and - keys to advance or back up a screen. There are three screens of symbols. (For convenience, the = key is equivalent to +.) If a symbol does not exist, the symbol box will be drawn as a vertical line. The user may view a single symbol at a time by selecting Alter and entering a symbol number. The + and - keys may be used to advance or back up one character at a time.

Symbol sets

The following Symbol sets (fonts) are available. The sets may be altered using the ALTERSYM program.

SET1 SYM Similar to default	SET10 SYM Triplex Roman
SET2 SYM Simplex Greek	SET11 SYM Triplex Italics
SET3 SYM Script	SET12 SYM Old German
SET4 SYM Simplex Roman	SET13 SYM Olde English
SET5 SYM Duplex Greek	SET14 SYM Old Italian
SET6 SYM Simplex Italics	SET15 SYM Special Symbols
SET7 SYM Duplex Hershey	SET16 SYM Special Symbols
SET8 SYM Duplex Script	CENTERED SYM Centered Symbols
SET9 SYM Cyrillic	

For math symbols, use SET15 and SET16.

Using the Help System

To obtain help relevant to the current topic press F1, the HELP key. To obtain further help, select any of the options at the top of this screen.

To select a Help option either type the first letter of the option or position the pointer with the arrow keys and press the Enter key.

To exit the help system and return to the ALTERSYM menus, press the Esc key.

Special Keys

The following keys have special purposes.

F1	Help
F2	View the symbol set on screen
F3	Return to ALTERSYM Menu
F4	Save all current settings in a specified command file
Shift F4	Store highlighted setting in command file ALTERSYM.CMD
F5	Directory
Esc	Back up 1 level (Exits ALTERSYM at the ALTERSYM Menu)
Enter	Select current option; begin processing if on bottom row of pop-up
Arrow keys	Move highlighted pointer
Home, End	Move to the beginning or end of a text line

Topic Menus

Two different types of menus are used to make choices. The first type appears on the upper two lines of the screen. This type of menu is used to rapidly select major topics and is called a topic menu. The menu at the top of this screen is a topic menu. Arrow keys may be used to move the highlighted pointer to different options. As different options are highlighted a brief explanation of the current option will be displayed on the second row of the screen. After positioning the pointer to the desired option, it may be selected by pressing the Enter key. Options may be rapidly selected by typing the first letter of the desired option.

If Esc is pressed while in a topic menu, the previous menu will be displayed. Esc may be pressed until there are no more previous menus. In this case the program will end and return to DOS.

A second type of menu known as a pop-up menu will appear in various places in the lower portion of the screen. These menus are used to specify several related values at one time. The arrow keys will move the highlight from one field to another. To change an option simply type in the desired value and press Enter or the Up or Down arrow keys. Pressing the Enter key with the pointer on the bottom field will accept the current values and begin any related processing.

The Esc key may be pressed at any time to back up 1 level. If a string or value is being changed when Esc is pressed, the previous string or value will be restored. Pressing Esc a second time will exit the menu.

CmdLine

The format of the ALTERSYM command line is

ALTERSYM [options] [Symbol file]

where options can be any of the programmable ALTERSYM variables that appear in the ALTERSYM command file. Any variables that appear on the command line will override those in the command file. All options must be immediately preceded by a / or - character. Options must be separated with spaces or tabs. Strings containing blanks or tabs must be enclosed in double quotes. Type the ALTERSYM.CMD file for a complete list of valid options.

The last argument may be a file specification for a symbol file in the format used by the ALTERSYM program. ALTERSYM will read the file and place the user at the ALTERSYM Menu.

Example ALTERSYM /SCRTYPE=AUTOMATIC TEST SYM

Environ

The Environ menus are used to configure ALTERSYM for the installed hardware. In most cases, ALTERSYM will make reasonable guesses as to the monitor type, colors, etc. but in some cases it may be desirable to override the default values.

ScreenType configures parameters related to the monitor such as the type of adapter, and whether to eliminate snow, use the BIOS, or write directly to the video buffer during display output. Viewing parameters may also be specified including the size of plot to fit on the screen and the plot origin.

Menu colors are set in the MenuColor menu, while plot colors are set in the ViewColor menu. Plot colors are used while viewing a symbol on the EGA or VGA adapters.

DataPath specifies the path for input and output files.

DataPath

Enter a path for all input and output files (data files, grid files, level files, text block files, posting files, color zone files, etc. etc.). In other words, this path refers to those files referring to the users' data of which control the plotting of said data.

This path does not apply to ALTERSYM.CMD. That is expected to be in the same directory as ALTERSYM.EXE.

If no disk drive is specified, the currently active drive is used.

If the disk drive is specified with no directories, the currently active directory for that drive is used.

If the path specification is deleted or blanked, the currently active directory is used.

There are 3 paths of interest:

1. The path as specified under DataPath
2. The path used to activate ALTERSYM
3. The currently active directory.

The last is used only if the first is blank or deleted.

ScreenType

Use this menu to configure the display type and characteristics. In general, the default settings should be adequate and are best left alone. If it is necessary to change a setting, it may be saved with the Shift-F4 key.

Graphics adapter Use this option to specify the type of graphics adapter installed on the computer. The default setting of Auto will allow ALTERSYM to determine which adapter is installed. Care should be used when changing this option, since damage to the monitor may result from invalid settings.

Screen width This is the plot width in inches to display horizontally.

across the screen when viewing a plot. This does not have to be the physical width of the screen. As an example, if screen width is set to 2 inches, the entire screen will be used to plot a 2 inch portion of the plot starting at the current screen origin. This is similar to zooming in on a plot; more detail is shown, but portions of the plot will be off the screen.

Screen origin The screen origin is the X,Y coordinates in inches of the lower left corner of the screen. This is used to specify the position of a plot on the screen. When zooming in with the screen width option, the screen origin can be set to specify which portion of the plot to place on the screen.

Eliminate snow Snow consists of random flashes of light when the display is being written to. Usually, ALTERSYM will correctly determine whether snow elimination is necessary and automatically set this value. Snow elimination is usually only necessary on IBM color graphics cards (not EGA's), and will slow output considerably. This value is ignored if the BIOS is used.

BIOS ALTERSYM will usually write directly to the video buffer for performance reasons. On some compatibles or multitasking operating systems, this may cause problems. To use the ROM BIOS for all screen output answer YES to this prompt. Note that this will slow all screen output.

MenuColor

This menu allows selection of the three colors used in all of ALTERSYM's menu screens. All possible colors are displayed on the popup, even though some of the colors may not be visible on monochrome monitors. To save the selected colors, use the Shift-F4 key to store the value in the command file.

ViewColor

Currently, the EGA and VGA adapters are the only supported adapters with plotting colors. Since it is often desirable for the pen colors of a plotter to represent the same colors on the screen, this menu allows the pen numbers to be assigned to an EGA (VGA) color value.

Blue	1	EGA color values are calculated by mixing the 6 base colors
Green	2	from the table at left. The colors are mixed by adding in
Red	4	the desired color's numeric code. For example, pure red has
Dark Blue	8	a color value of 4. High intensity white (a mixture of all
Dark Green	16	colors) is $1+2+4+8+16+32 = 63$. Black is the absence of all
Dark Red	32	color, and has an EGA color value of 0. The brightest colors are

formed by a combination of the normal and dark colors.

For monochrome EGA's the only possible color values are 0, 8, and 24. Even though 64 colors are possible, only 16 may be displayed at once on a 256K EGA, and only 4 colors at once on a 64K EGA. These limits are imposed by the EGA hardware.

GRID Menu

GRID creates and manipulates files of regularly spaced data points called grid files. SURF and TOPO use these files to create 3 dimensional surface plots and contour maps.

From the GRID Menu, select:

- Random to create a grid file from irregularly spaced data
- Function to create a grid file from a function of 2 variables
- Modify to smooth, blank, or modify an existing grid
- Environ to specify the hardware configuration

To learn more about the help system, select the desired topic above with the arrow keys, and press Enter. Press the Esc key to exit the help system and return to GRID.

Random Menu

The Random menu contains all options related to creating a grid from random or irregularly spaced XYZ data. Each data point consists of 3 values; an X, Y, and Z coordinate. See the GRID manual for examples of randomly spaced data.

Usually the first step is to get the XYZ data into GRID. The Input option will accept data from the keyboard or from several different types of data files. After the data is entered, the other options in the Random menu are used to control the gridding process.

Output assigns a name to the output grid file. Duplicate tells GRID how to handle points with identical XY coordinates. GridSize specifies the size or density of the final grid. In general, the denser the grid, the smoother and more detailed the final plots will be. Method allows the user to specify the gridding method to use. See the GRID manual for a discussion of the merits of the various gridding techniques. Search will set the parameters used to search for data points during the gridding process. Limits specifies the coordinates of the edge of the grid. Begin is used to begin creating the grid after all the above parameters have been set to their desired values.

Function Menu

The Function menu is used to create a grid from a user specified function of 2 variables. These variables must be named X, Y, and Z, and correspond to the X, Y and Z coordinates of a point to be calculated. See the grid manual for examples of valid functions.

The function is evaluated at discrete points corresponding to the grid nodes. The coordinates of these points and the grid density are calculated from the minimum, maximum, and increment values input by the user. If the minimum, maximum, and increment values are 1, 10, and 1 for both the X and Y axes, the final grid will have (10 X 10) or 100 values.

Equations may be undefined over a portion of the grid resulting in math errors. For example, the equation $Z = X/Y$ will be undefined when $Y = 0.0$. If the Y range and increment are such that Y will equal 0.0, a math error will result and the grid node will be blanked.

If an "insufficient memory" error occurs while creating the grid, make sure the worksheet in (Random Input) is not being used, since it requires a large amount of memory.

Modify Menu

The Modify menu allows the user to change a previously created grid file. The Smooth option will smooth a grid to eliminate irregularities in the surface and produce a more aesthetic plot.

Blank will read in an existing file with coordinates of a region to be blanked. This region will be marked with special values in the grid file to eliminate contour and surface lines in the final plot.

Math is used to perform mathematical operations between two existing grid files of the same size. An equation is specified to define the mathematical operation. Any valid equation may be specified and may use any of GRID's built-in functions.

Input Menu

The Input option allows you to enter XYZ data from the keyboard or an existing data file. Edit will place you directly into GRID's worksheet where all XYZ data are stored. The worksheet is up to 26 columns by up to 16,000 rows depending on available memory.

Xiernal will input data from an existing ASCII or Lotus 123 file into the worksheet. This data may then be edited with the Edit option if desired.

Insert, Delete, Copy, and Move will perform operations on an entire group of data in the worksheet from a single cell to an entire range of cells.

Format will allow the user to change the way a numeric value is printed in the worksheet. Options exist for Fixed, Exponential, and General formats.

Transform will apply a user specified equation to the data in 1 or more columns to calculate a new column.

The Save option will save the current worksheet as an ASCII file.

Duplicate Menu

Duplicate data points have identical X and Y coordinates but not necessarily identical Z coordinates. Since the distance between these points is 0, many distance weighted gridding algorithms are unable to calculate a grid node for the data. To avoid this problem, GRID will make a pass through the input data to determine if any points are identical.

If the Average option is selected, all points with identical XY coordinates will have their Z coordinates averaged. All these points will be replaced by a single point representing the average.

Delete will treat duplicate data points as errors and will remove the points before the gridding process. The points are not deleted from the worksheet.

Since checking for duplicate points is time consuming for large grids, the Ignore option is included for users who are sure their data does not contain duplicate data points. The duplicate check is bypassed and gridding proceeds immediately.

GridSize Menu

GridSize is used to specify the density of the final grid. The limits of the grid do not change; only the number of grid nodes within the limits. A grid density of about 50 in each direction usually produces pleasing results. See the GRID manual for examples of the effects of different grid densities.

Grid density may be specified by the Number of grid lines along each side of the grid (X or Y). When this option is used, GRID will update the screen to reflect the Distance between grid lines at the new density. The two options are always synchronized.

The Distance between grid lines option allows the density of the grid to be specified by the distance between grid nodes in X or Y data units along each side of the grid. GRID will adjust these values to obtain an integer number of grid lines between the current grid limits if necessary. As an example, assume the grid limits along the longest side of the grid range from 0.0 to 7.0. If a distance of 2.0 is requested, GRID will adjust the distance to 2.333 since 2.0 will not divide into 7.0 evenly. A distance of 2.333 results in 4 grid lines.

The last option allows for different units in each direction. If Y units are feet and X units are inches, then enter 12, since 1 foot = 12 inches.

Method Menu

There are currently three different gridding methods available: Inverse distance, Kriging, and Minimum curvature. Inverse distance is faster than Kriging but does not represent the original data as accurately. Minimum curvature is usually the fastest method, if the maximum error is not set too small, and will honor original data by setting the nearest grid node to the data value (or average of the closest data values).

Inverse distance uses a weighted averaging technique to interpolate grid nodes from the XYZ data. The weights are inversely proportional to the distance to the grid node. Data points further away from a given grid node will have less influence. In addition, the weights may be raised to a power to increase the effect of the weighting function. Inverse distance squared is the most common weighting power.

Kriging uses geostatistical techniques to calculate the autocorrelation between data points and produce a minimum variance unbiased estimate. In theory, no other gridding method can produce more accurate estimates. In practice, the effectiveness of kriging depends upon proper selection of various parameters. These parameters are estimated by GRID and may not be exact. Even so, Kriging produces much more accurate maps than Inverse Distance.

Minimum curvature first examines all data and sets the nearest grid node to that data value (or average of data values), thus honoring the data. Note that this may not give satisfactory results for coarse grids or noisy data. Then the values at the other grid nodes are computed so as to give a gridded surface of minimum curvature through the set grid nodes. Because of the refinement method used, only odd grid sizes are allowed for Minimum curvature. If the maximum error is a reasonable value, considering the range of Z-values and required accuracy, and given a good distribution of data, then this method is the fastest of the three. However, if data are poorly distributed, for example, if there are no data over a large subregion, then the results for that subregion may be quite poor, and the method may be quite slow to converge. This method should not be used for extrapolation into large regions without data, as results are unpredictable, and it should only be used with caution if the data are quite noisy.

Search Menu

A search is performed by GRID to determine which XYZ data points to use in the calculation of the current grid node.

A Normal search will use the N nearest data points around the current grid node that are also within the specified search radius. N is specified at the Number of nearest points prompt.

Quadrant and Octant searches are similar to Normal searches except that the number of nearest points and search radius are applied to each quadrant or

octant respectively. These type of searches are used to insure that data points from all sides of the grid node are used rather than from just one direction. This will improve the accuracy of the grid for linearly oriented data.

The All option will disable searching and use all of the input data points to calculate each grid node. This can significantly reduce the amount of time required when a large number of closest points are desired anyway. A tradeoff is involved in that even though no time is spent searching, more time must be spent to use all of the data points in the grid calculations. See the GRID manual for examples of the different search methods.

Limits Menu

The limits of the grid refer to the XY coordinates of the grid edges. GRID will use the limits of the original XYZ data as default values for the grid limits. These values may be overridden to create a grid that is larger or smaller than the original data in areal extent. Note that extrapolation outside the data range will occur when the grid limits exceed the data limits. Since there is no data on the outside edge, the quality of the estimation will deteriorate.

When creating a grid smaller than the original data, it is possible to either include or exclude the data points outside the grid limits in the gridding calculations. Answering No to the Discard data outside limits prompt will include outlying data in the gridding process.

Columns

The X, Y, and Z columns for gridding may be selected.

For example, the X column may be the 2nd in the data file, the Y column may be the 5th, and the Z column may be the 9th. In this case, if the file has not yet been read into the worksheet, then 9 columns will be the default for allocation. If the user has read fewer than 9 columns, or allocates fewer than 9 columns, or if any of these columns do not exist in the data file (or do not have numerical data), then an error will result.

Edit Screen

Edit mode is used to enter data from the keyboard. Numeric or label data may be entered. To enter a numeric label precede the label with a single or double quote. A column of data may only be text or numeric, never both. The type is determined after the first value is entered in the column. To reset the column type all data from the column must be removed.

The following keys may be used for editing.

Up	Moves block cursor up 1 row
Down	Moves block cursor down 1 row
Left	Moves block cursor left 1 column
Right	Moves block cursor right 1 column
PgUp	Moves up 1 screen full
PgDn	Moves down 1 screen full
Shift-Left	Moves left 5 columns (1 screen full)
Shift-Right	Moves right 5 columns (1 screen full)
Home	Moves to top row in current column
End	Moves to bottom row in current column
Shift-Home	Moves to first column
Shift-End	Moves to last column
/ or Esc	Returns to Input menu

Xternal Menu

The Xternal menu is used to read an existing data file into GRID's worksheet. The data file may be in either Text (ASCII) or Lotus WKS or WK1 formats. Worksheet columns are formatted for either label or numeric data but never both. After GRID has formatted a column for a given data type it will ignore any lines in the data file that violate the current column format. Because of this, all data in a given column must be of the same type (label or numeric).

Text files may be viewed on the screen with the DOS TYPE command and consist of normal printable characters only. Only as many columns are read into GRID's worksheet as are allocated. Each line in the file will become one row in the worksheet. The data may be separated with spaces, tabs, or commas. Strings must be enclosed in single or double quotes if they contain spaces, tabs, or commas.

WKS or WK1 files are normally created from Lotus 123 or Symphony. Only as many columns are read into GRID's worksheet as are allocated, unless Auto allocation is selected. The data must be formatted in columns; there is no way to transpose rows to columns.

Block Operations

All block operations operate on a range of cells. A range of cells is specified by two opposite corners of a rectangular block as in A1:B5. In this example, the range includes all cells in the rectangle with the upper left corner at column A row 1, and the lower right corner at column B row 5. A single cell may be specified as in C12:C12.

Insert will insert the specified rows or columns into the worksheet. All existing rows or columns will move down or to the right to make room.

Delete will delete the specified rows or columns from the worksheet. All existing rows or columns will move up or left to fill in the deleted block.

If Worksheet is selected, the entire worksheet will be deleted and deallocated.

Copy copies an entire range of cells to another location in the worksheet. The destination cell refers to the upper left corner of the copied block.

Move will move a range of cells to a new location. Columns and rows will move in to fill the original block as in the delete option above.

Format Menu

The Format option is used to specify the format for numeric values in a given column. The entire column is formatted at once. It is not possible to format only part of a column.

Transform Menu

Transform is used to calculate a column of data from 0 or more existing columns of data. The calculation is based on a user specified equation. The equation may have column variables corresponding to the column letters of the worksheet.

As an example, consider the equation $C = A + \sin(B)$. GRID will calculate the sum of column A and the sin of column B, and place the result in column C. This process will continue for each row that has a value in row A and B. The equations are not stored in the worksheet, so column C in the above example would not be updated if a subsequent change was made to column A or B. If data is missing from column A (or B) on some rows, then no calculation will be performed for those rows.

Save Menu

The Save option is used to save the current contents of the worksheet to a disk file. Save files are always ASCII text files. Columns are delimited by spaces in the files, and rows by carriage returns. GRID does not automatically save the worksheet, so it is a good idea to periodically Save the worksheet when making many changes.

Smooth Menu

There are currently two different smoothing methods available in GRID. Spline smoothing will fit a cubic spline to the input grid and interpolate additional values for the output grid. This results in a denser grid with the original data points preserved.

Matrix smoothing passes a user defined smoothing matrix over the input grid. Data under the smoothing matrix is weighted and averaged to produce the output grid. Since this operation is undefined at the edges of the grid, the output grid will be smaller. Because of the averaging process, the output grid will have lower highs and higher lows than the input grid.

Blank Menu

Specified portions of the grid file may be set to a special value and blanked during the creation of the plot. Blanked areas will appear as flat regions in surface plots and will cause suppression of contour lines in contour maps.

Blanked regions are specified by a sequence of X,Y coordinates defining a closed polygon. If the polygon does not close, GRID will add a segment to close the polygon. Polygon sides must not cross. A blanking file is used to specify the region to blank. The first line is a header consisting of the number of points to follow and the side flag. If the side flag is 0, grid elements outside the polygon are blanked. If the side flag is 1, the grid elements inside the polygon are blanked. The entire sequence may be repeated any number of times to blank multiple regions. In the example to the left, the inside of a triangular region will be blanked.

Math Menu

The Math option allows two existing, identically sized grids to be combined mathematically to form a third output grid. If the grids are different sizes on disk, a subset may be read in so that the final sizes are identical.

An equation is used to specify how to combine the two input grids. The equation is a function of 2 variables named A and B. These variables correspond to the two input grids. Any of GRID's built-in functions may be used in the equations.

Matrix Smoothing

Matrix smoothing passes a smoothing matrix over an existing grid to average those grid points nearest each grid point to be smoothed. The matrix is specified by the number of columns and rows on either side of the grid point to be smoothed, and the weight of the center point of the matrix.

1 2 3 4 5 6 7 In the example at left, + signs represent grid nodes, while 1 + + + + + x's and the 0 represent the smoothing matrix. The grid is 2 + x x x x + 5 rows by 7 columns, the smoothing matrix is 3 rows by 3 + x x o x x + columns. The grid node currently being smoothed is row 3 4 + x x x x + column 4. Each grid node under an x will be weighted by 5 + + + + + the value of the smoothing matrix and averaged in to obtain a new value for the center grid node. The matrix will then be shifted and the process repeated until the entire grid is smoothed. Notice that the edges of the grid are undefined and will be blanked.

For non-distance weighted smoothing, the x nodes will have a weight of 1/0 and

the 0 node will be assigned the center point weight. Distance weighted smoothing will assign weights to each x based on the inverse of the distance to the center raised to a specified power.

Spline Smoothing

Spline smoothing fits a cubic spline to an existing grid to interpolate new values between existing grid nodes. This increases the density of the grid allowing smoother contours and surfaces. The X and Y expansion factors refer to the number of points to insert between existing grid nodes in the X and Y directions respectively. Spline smoothing may increase the highs and lows of the original grid.

- * * * * * In the example at left, the asterisks represent
- ... the original 3 by 5 grid. The nodes represented
- ... by the dots were interpolated using cubic spline
- * * * * * smoothing. 1 point was calculated between each node
- ... in the X direction, and 2 points were calculated
- ... between each node in the Y direction to give a
- * * * * * final grid of 7 rows by 9 columns.

Either the expansion factors or the new numbers of columns and rows may be specified. For example, the X expansion factor may be set to 2 (the default value) and the number of rows (Y direction) may be set to 33. However, the Y expansion factor may not be set if the number of rows is set, as these are mutually exclusive.

Using the Help System

To obtain help relevant to the current topic press F1, the HELP key. To obtain further help, select any of the options at the top of this screen.

To select a Help option either type the first letter of the option or position the pointer with the arrow keys and press the Enter key.

To exit the help system and return to the GRID menus, press the Esc key.

Special Keys

The following keys have special purposes:

- F1 Help
- F3 Return to GRID Menu
- F4 Save all current settings in a specified command file
- Shift F4 Store highlighted setting in command file GRID.CMD
- F5 Directory
- Esc Back up 1 level (Exits GRID at GRID Menu)
- Enter Select current option, begin processing if on bottom row of pop-up
- Arrow keys Move highlighted pointer

Topic Menus

Two different types of menus are used to make choices. The first type appears on the upper two lines of the screen. This type of menu is used to rapidly select major topics and is called a topic menu. The menu at the top of this screen is a topic menu. Arrow keys may be used to move the highlighted pointer to different options. As different options are highlighted a brief explanation of the current option will be displayed on the second row of the screen.

After positioning the pointer to the desired option it may be selected by pressing the Enter key. Options may be rapidly selected by typing the first letter of the desired option.

If Esc is pressed while in a topic menu, the previous menu will be displayed. Esc may be pressed until there are no more previous menus. In this case the program will end and return to DOS.

A second type of menu known as a pop-up menu will appear in various places in the lower portion of the screen. These menus are used to specify several related values at one time. The arrow keys will move the highlight from one field to another. To change an option simply type in the desired value and press Enter or the Up or Down arrow keys. Pressing the Enter key with the pointer on the bottom field will accept the current values and begin any related processing.

The Esc key may be pressed at any time to back up 1 level. If a string or value is being changed when Esc is pressed, the previous string or value will be restored. Pressing Esc a second time will exit the menu.

Equation Calculation

Equations are specified using standard infix notation and precedence rules. Operators in order of decreasing precedence are:

- unary minus
- * / multiplication and division
- + - addition and subtraction

Operators of equal precedence are evaluated from left to right. Parentheses may be used to override precedence or for clarity. The following built-in functions are supported:

- acos(x) Returns the arc cosine of x in the range 0 to π .
The value of x must be between -1 and 1 .
- asin(x) Returns the arc sine of x in the range $-\pi/2$ to $\pi/2$.

The value of x must be between -1 and 1 .

- atan(x) Returns the arc tangent of x in the range $-\pi/2$ to $\pi/2$.
- atan2(y, x) Returns the arc tangent of y/x in the range $-\pi$ to π .
- ceil(x) Returns the smallest integer that is greater than or equal to x .

Built-in Functions (continued)

- cos(x) Returns the cosine of x .
- cosh(x) Returns the hyperbolic cosine of x .
- exp(x) Returns the exponential function of x (e to the x).
- fabs(x) Returns the absolute value of x .
- floor(x) Returns the largest integer less than or equal to x .
- fmod(x, y) Returns the floating point remainder of x/y .
- j0(x) Returns the Bessel function of the first kind of order zero at x .
- j1(x) Returns the Bessel function of the first kind of order one at x .
- jn(n, x) Returns the Bessel function of the first kind of order n at x .
- log(x) Returns the natural logarithm of x .
- log10(x) Returns the base 10 logarithm of x .
- min(x, y) Returns the smaller of x and y .
- max(x, y) Returns the larger of x and y .
- pow(x, y) Returns x raised to the y th power.
- randn(x, y) Returns a normally distributed (Gaussian) random number with mean x and standard deviation y .
- randu(x) Returns a uniformly distributed random number from the interval 0 to x .
- sin(x) Returns the sine of x .
- sinh(x) Returns the hyperbolic sine of x .
- sqrt(x) Returns the square root of x .
- tan(x) Returns the tangent of x .
- tanh(x) Returns the hyperbolic tangent of x .
- y0(x) Returns the Bessel function of the 2nd kind of order zero at x .
- y1(x) Returns the Bessel function of the 2nd kind of order one at x .
- yn(n, x) Returns the Bessel function of the 2nd kind of order n at x .

CmdLine

The format of the GRID command line is:

GRID [options] [XYZ data file]

where options can be any of the programmable GRID variables that appear in the GRID command file. Any variables that appear on the command line will override those in the command file. All options must be immediately preceded by a / or - character. Options must be separated with spaces or tabs. Strings containing blanks or tabs must be enclosed in double quotes. Type the GRID.CMD file for a complete list of valid options.

The last argument may be a file specification for an XYZ data file to be gridded. An XYZ data file consists of an X , Y , and Z coordinate on each line of the file. This is the same type as that read in from the Xternal option in the worksheet. GRID will read the file and automatically bring up the Random menu.

Example: GRID /GRDNL = 50 /GM = KRIGING TEST.DAT

GridIO

Grid files may be written in one of two formats: Binary or ASCII. Binary is much faster and creates smaller files. However, Binary files cannot be typed, edited, or imported into programs other than those by Golden Software. Because of these limitations, files may be output as ordinary ASCII text files. These files may then be imported into editors and other programs for further processing or modification.

During input, it is possible to specify a sub-grid within the grid file. The questions pertaining to first and last rows and columns refer to the limits of the sub-grid to read. GRID will extract only those rows and columns from the grid file that comprise the specified sub-grid. The default range of 1 to 32767 will read the entire grid.

Format

Numeric values may be formatted in a Fixed, Exponential, or General format. With each of these methods, the user may specify the number of digits to the right of the decimal point. Internally all numeric values are stored as 32 bit entities. This is equivalent to approximately 7 digits of precision.

Fixed format is of the form $[-]xxxx.xxxx$ where $xxxx$ is one or more digits. The number of digits before the decimal point depends on the magnitude of the number.

Exponential format will print values with the form $[-]x.xxxxE[sign]xxx$, where x is a single digit, $xxxx$ is one or more digits, and xxx is exactly three digits, and sign is + or -.

General format will print values in Fixed or Exponential format whichever is more compact for the given value and precision. Trailing zeros are truncated and the decimal point appears only if one or more digits follow it.

Environ

The Environ menus are used to configure GRID for the installed hardware. In most cases, GRID will make reasonable guesses as to the monitor type, colors,

etc. but in some cases it may be desirable to override the default values
DataPath specifies the path for input and output files

ScreenType is used to specify display output parameters. The first is whether to eliminate snow or not. Snow consists of random flashes of light when the display is being written to. Snow elimination is usually only necessary on IBM color graphics cards (not EGA's), and will slow output considerably. This value is ignored if the ROM BIOS is used.

On some compatibles or multitasking operating systems it is necessary to use the ROM BIOS for display output. To use the ROM BIOS for all screen output answer YES to the BIOS prompt in the ScreenType popup. Note that this will slow all screen output.

The MenuColor menu allows selection of the three colors used in all of GRID's menu screens. All possible colors are displayed on the popup, even though some of the colors may not be visible on monochrome monitors. To save the selected colors, use the Shift-F4 key to store the value in the command file.

DataPath

Enter a path for all input and output files (data files, grid files, etc.). In other words, this path refers to those files referring to the users' data or which control the gridding of said data.

This path does not apply to GRID.CMD. That is found in the same directory as GRID.EXE.

If no disk drive is specified, the currently active drive is used.

If the disk drive is specified with no directories, the currently active directory for that drive is used.

If the path specification is deleted or blanked, the currently active directory is used.

There are 3 paths of interest:

1. The path as specified under DataPath.
2. The path used to activate GRID.
3. The currently active directory.

The last is used only if the first is blank or deleted.



**FACULTAD DE INGENIERIA U.N.A.M.
DIVISION DE EDUCACION CONTINUA**

CURSOS ABIERTOS

**“ IX CURSO INTERNACIONAL DE
CONTAMINACIÓN DE ACUÍFEROS “**

MODULO III

MODELOS MATEMÁTICOS EN GEOHIDROLOGÍA

TEMA

**MODELÓ DE FLUJO
(PLASM)**

**EXPOSITOR: ING. DAVID GONZÁLEZ POSADAS
1997**

- PRICKETT LONNQUIST AQUIFER MODEL SYSTEM (PLASM)

MODELO MATEMATICO PARA SISTEMAS ACUIFEROS

DESCRITO POR EL METODO DE DIFERENCIAS FINITAS PARA RESOLVERSE POR (METODO NUMERICO) UNA VARIANTE DE METODO IMPLICITO EN DIRECCION ALTERNANTE.

AUTORES. T.A. PRICKETT Y C.G. LONNQUIST
ILLINOIS STATE WATER SURVEY
U.S.G.S. BULLETIN 55, 1971.

FUNDAMENTOS MATEMATICOS.

LA ECUACION DIFERENCIAL EN DERIVADAS PARCIALES (BITTINGER Y OTROS, 1967) QUE DESCRIBE EL FLUJO BIDIMENSIONAL EN REGIMEN TRANSITORIO, EN UN ACUIFERO CONFINADO, HETEROGENEO E ISOTROPO ES:

$$\frac{\partial}{\partial x} \left(T \frac{\partial h}{\partial x} \right) + \frac{\partial}{\partial y} \left(T \frac{\partial h}{\partial y} \right) = S \frac{\partial h}{\partial t} + Q$$

DONDE:

- T= TRANSMISIVIDAD
- h= ALTURA PIEZOMETRICA
- t= TIEMPO
- S = COEFICIENTE DE ALMACENAMIENTO
- Q= DIFERENCIA DE CAUDALES (EXTRAIDOS Y RECARGADOS) POR UNIDAD DE AREA.
- X.Y= COORDENADAS RECTANGULARES

PLANTEAMIENTOS DE LAS ECUACIONES.

CONDICION DE CONTINUIDAD O CONSERVACION DE MASA

CAMBIO EN EL ALMACENAMIENTO	=	FLUJOS DE ENTRADA	-	FLUJOS DE SALIDA
Q5	=	Qn + Q1 + Q3	-	Q6 - Q4 - Q2

- Q1 a Q4 => TRANSFERENCIAS DE AGUA DE UN NUDO A OTRO. FLUJOS DEL ACUIFERO.
- Qs => CANTIDAD DE AGUA INCORPORADA O LIBERADA DEL ALMACENAMIENTO POR UNIDAD DE TIEMPO. POSITIVO CUANDO SE LIBERA AGUA. 24

FLUJOS DEL ALMACENAMIENTO

Q6 => CAUDAL CONSTANTE DE BOMBEO
Q(I,J) = SALIDA (+) ENTRADAS (-)
Q(I,J) = EXTRACCIONES - RECARGA ART.

Qm => ACCIONES ESPECIALES: INFILTRACION INDUCIDA;
EVAPOTRANSPIRACION; REZUMEN (INFILTRACIONES)

TRES CONSIDERACIONES:

- 1) DEFINIR LA PARTE DEL ACUIFERO QUE INTERVIENE EN CADA TERMINO
- 2) LOS CAUDALES ESTAN RESTRINGIDOS A LAS COORDENADAS X y Y, POR LO QUE SE TOMAN LAS PROYECCIONES ORTOGONALES.
- 3) BALANCE INSTANTANEO

PROCEDIMIENTO DE TRABAJO PARA EL PLASM.

- 1) DISCRETIZACION DE LAS PROPIEDADES FISICAS (SUPERPOSICION DE UNA MALLA)

NC (NUMERO DE COLUMNAS)
NR (NUMERO DE RENGLONES)

- 2) ASIGNACION DE VALORES COMUNES
T, FACTOR DE ALMACENAMIENTO (S)
h₀ (NIVEL INICIAL) Y Q DE BOMBEO

- 3) ZONAS ESPECIALES

A) BORDE DEL ACUIFERO -> T = 0
NO SE PUEDE S=0 (DIVISION CERO)

B) ADEMAS DE AGUAS SUPERFICIALES
LAGOS, MARES => S = 1

(FIG. NO. 10 p 33. DIAGRAMA DE FLUJO)

=

=

EJEMPLOS: MALLA DE TAMAÑO UNIFORME
ACUIFERO PROPIEDADES HOMOGENEAS E
- SOLUCION TEORICA ISOTROPIAS
NIVELES PIEZOMETRICOS INICIALES = CERO
INCREMENTOS DE TIEMPOS IGUALES

CASO DE ACUIFERO ILIMITADO

- 1) NR y NC = 31 ; LADO DE MALLA 300 m
- 2) T = 100 m²/dia
S = 0.01
W = 900 m³/m
H = 0
Q₀ = 0 m³/dia
- 3) DELTA = 0.5 dias
NSTEPS = 40
- 4) Q(16,16) = 4000 m³/dia

INFORMACION BASICA PARA LA IMPLANTACION DE UN MODELO

1.- DISCRETIZACION

- Planos Topográficos. Parteaguas.
- Plano Geohidrológico.
- Delimitación del Area
- Geología Subterránea. Cortes
Litológicos.
- Registros Eléctricos. Perfiles
Geológicos.
- Geofísica. Geometría de las
Formaciones en el Subsuelo.
- Censo de Aprovechamientos.
Localización de Pozos Piloto.
- Selección de la Malla. Areas de
Concentración de Información.

CORTE TRANSVERSAL ESQUEMATICO A LO LARGO DEL RENGLON 17

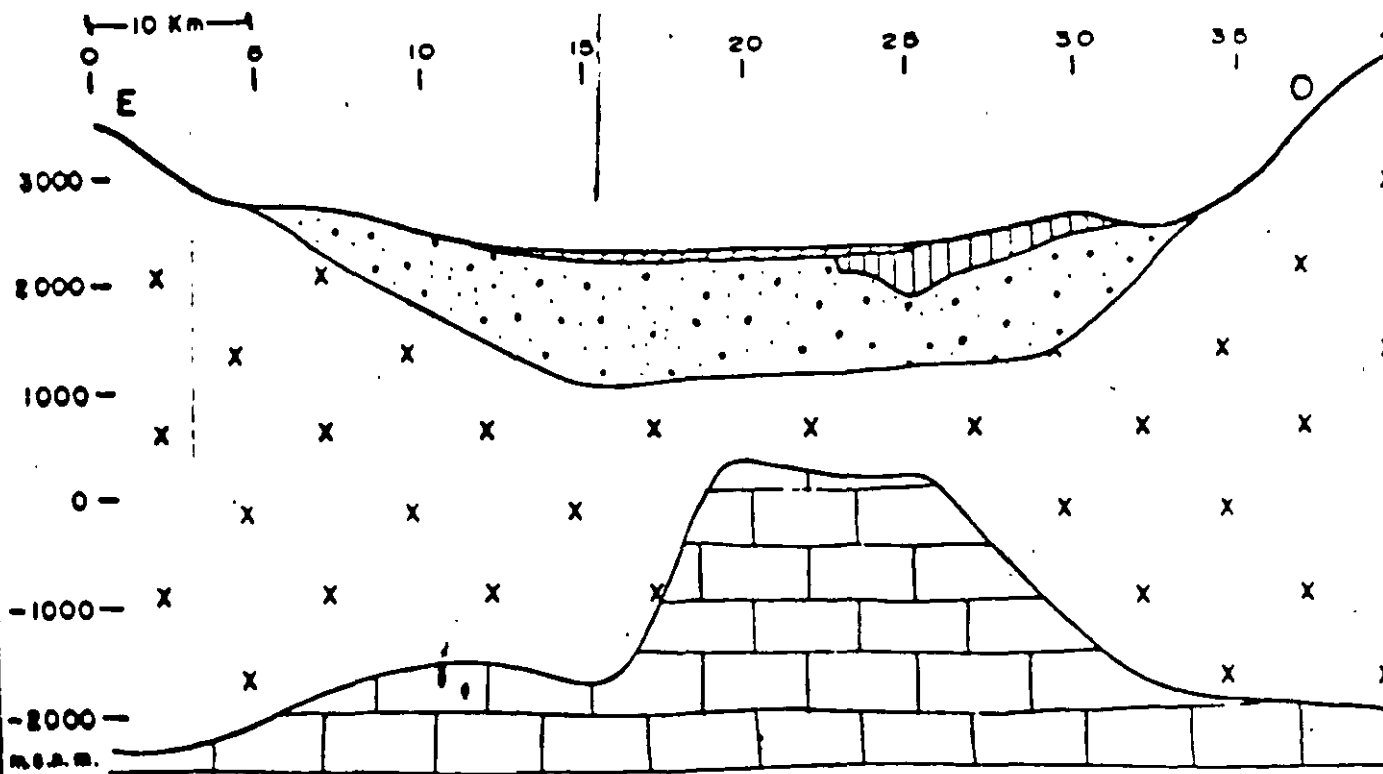

CORTE TRANSVERSAL ESQUEMATICO A LO LARGO DE LA COLUMNA 15

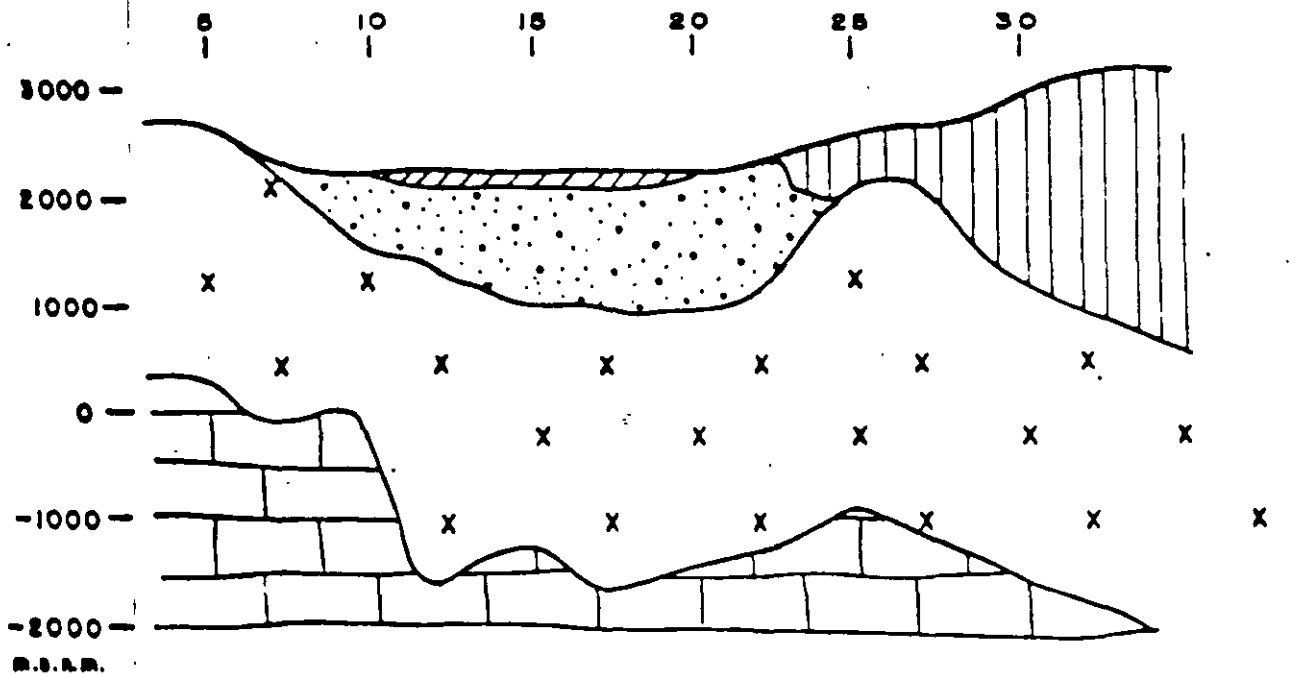

ACUITARDO SUPERIOR		BASALTO CUATERNARIO		ACUIFERO GRANULAR	
ACUIFERO VOLCANICO		ROCAS CARBONATADAS SEDIMENTARIAS			

FIG. . CORTES TRANSVERSALES ESQUEMATICOS

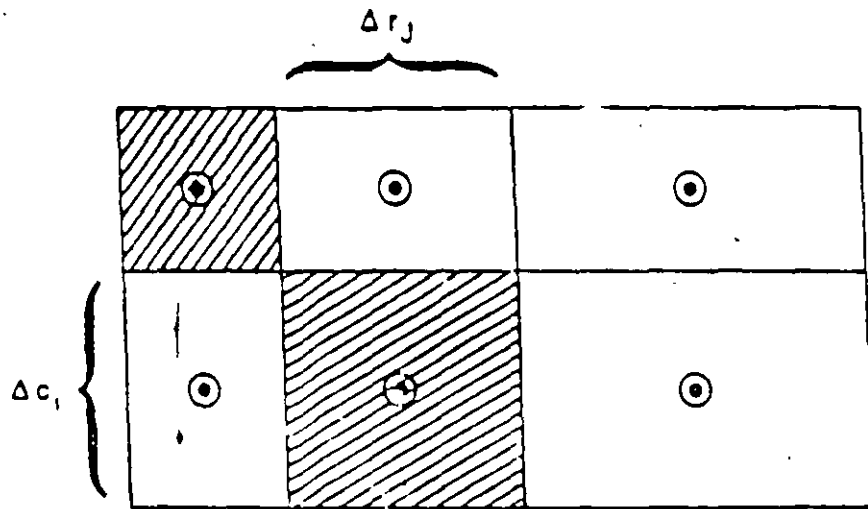
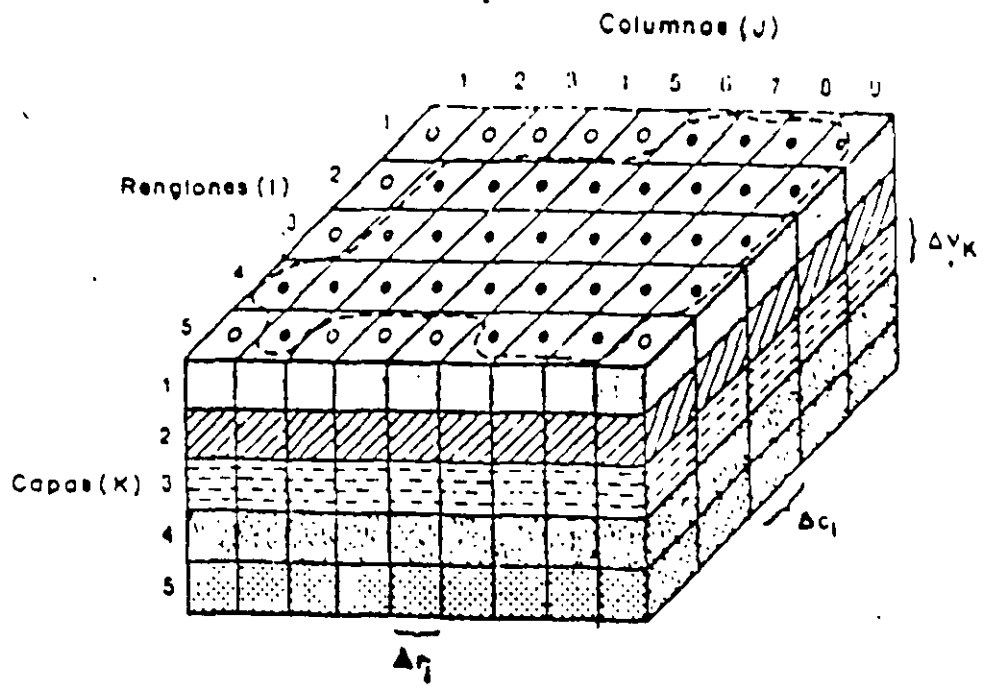

Sistema de Celda Centrada

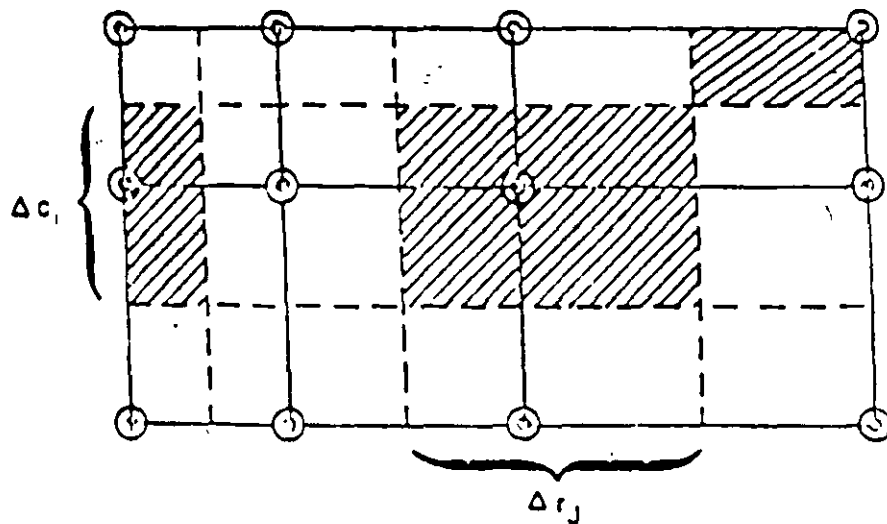

Sistema de Nodo Centrada

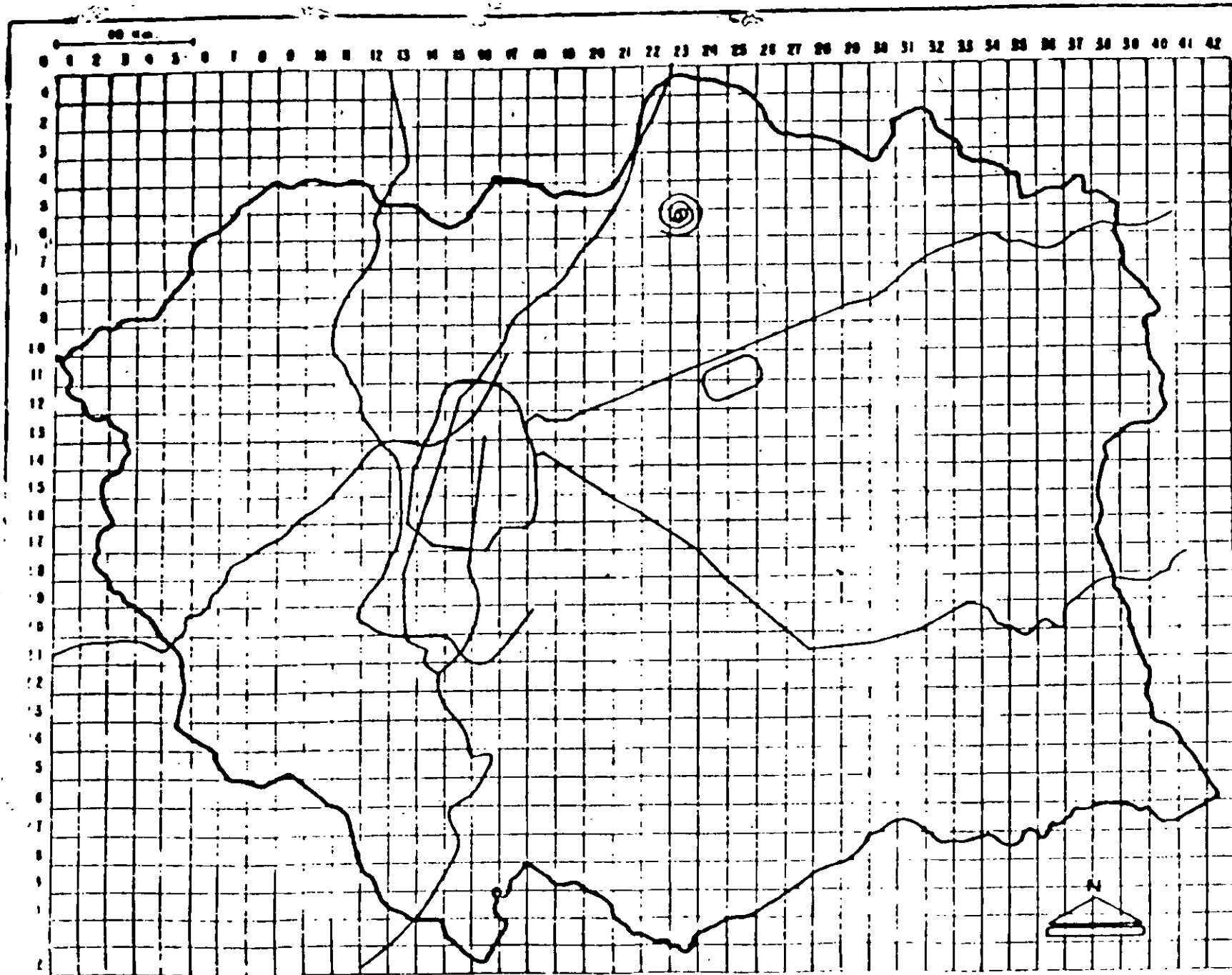

FIG. 3 . ILUSTRACION EN PLANTA ' LAS CELDAS DEL MODELO

INFORMACION BASICA PARA LA IMPLANTACION DE UN MODELO

2.- PARAMETRIZACION

- Pruebas de Bombeo. Aforos en pozos.
- Interpretación de Características
T, S, b, K, Ss, K'.
- Distribución espacial de Características
Hidrodinámicas.
- Adaptación de Características por Celdas.
- Construcción de Matrices de Parámetros.

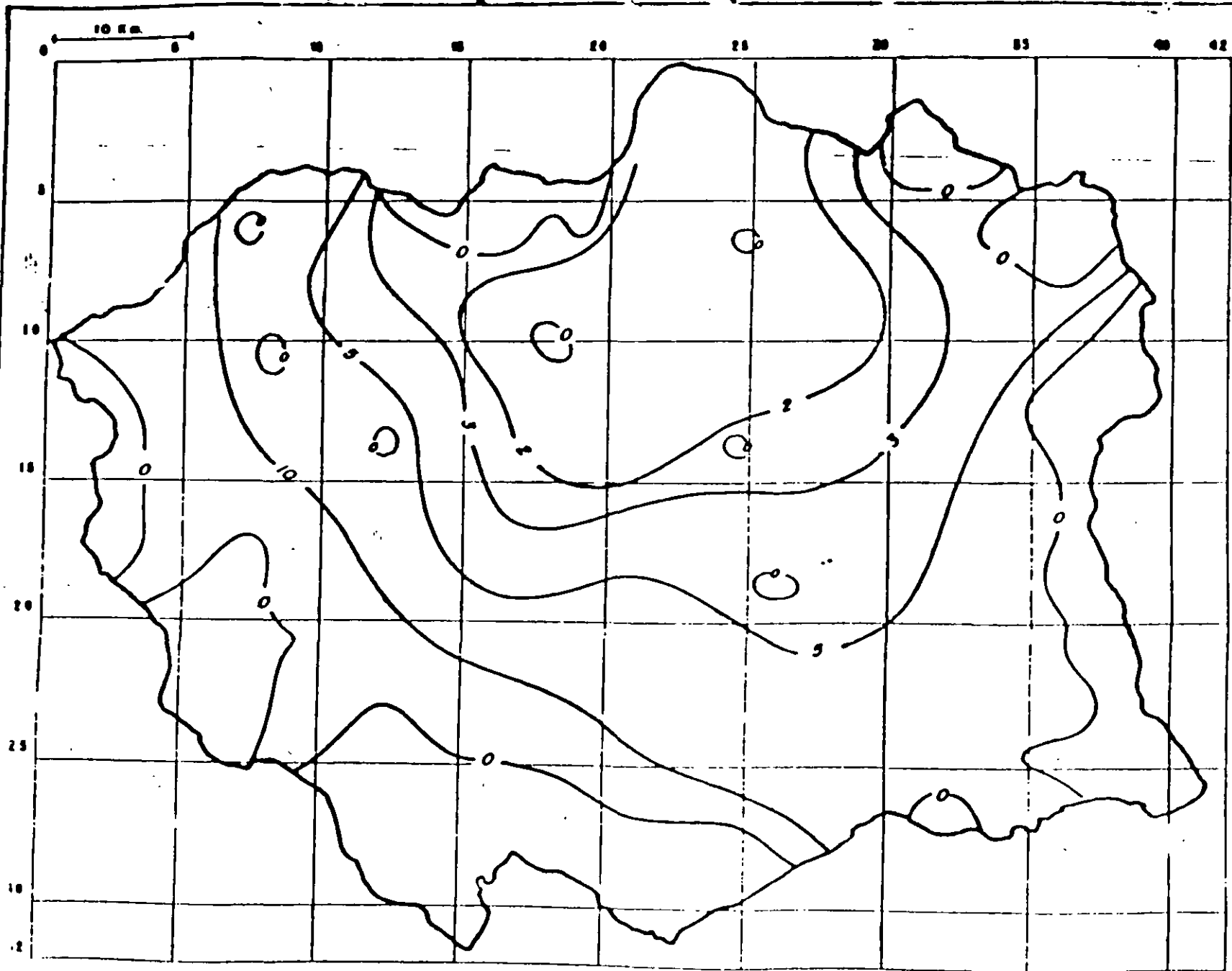

FIG. 7. COEFICIENTE DE ALMACENAMIENTO ESPECIFICO DEL ACUIFERO GRANULAR. $10^{-6} m^{-1}$

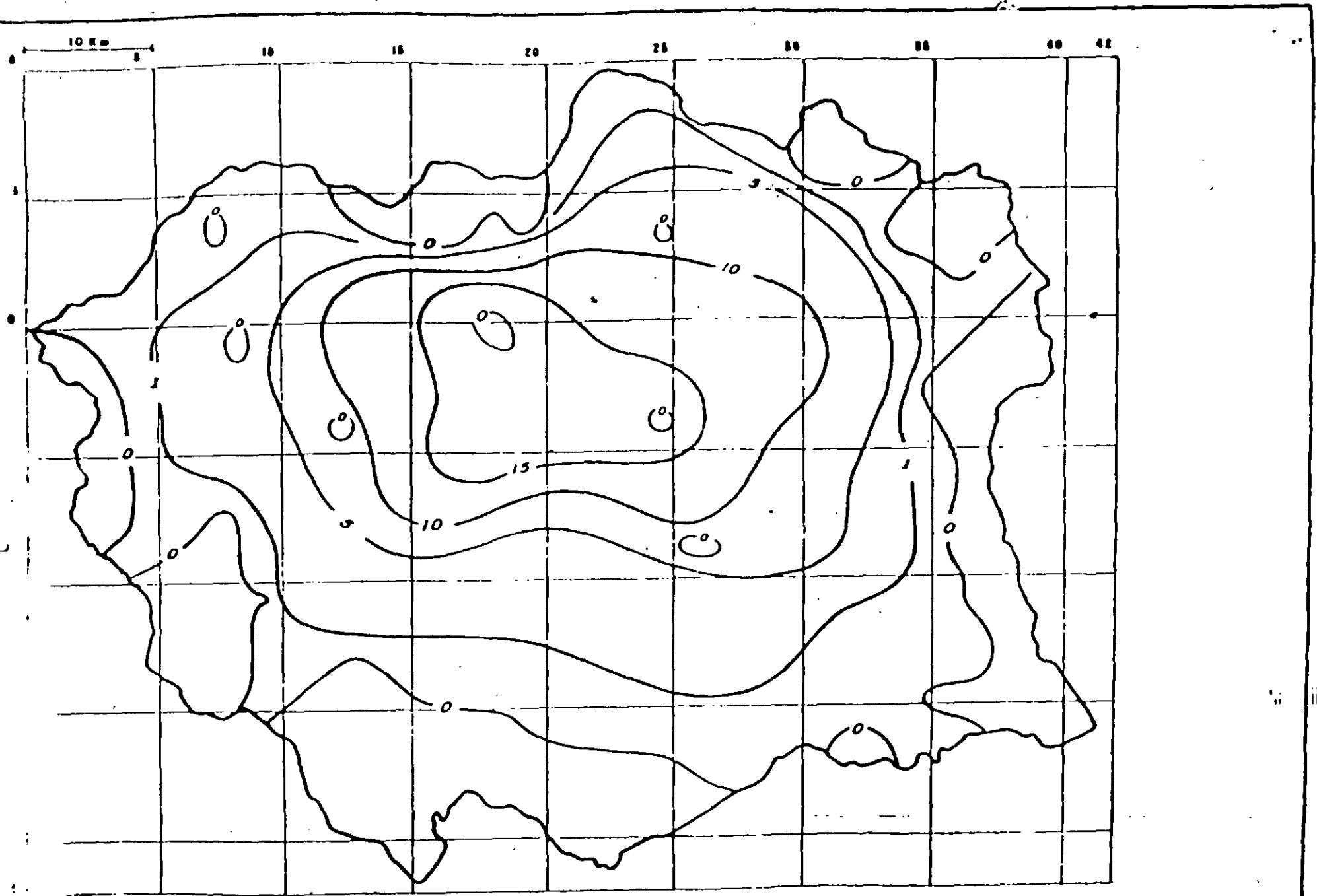

FIG. 6 CONDUCTIVIDAD HIDRAULICA HORIZONTAL DEL ACUIFERO GRANULAR 10^{-5} m/seg.

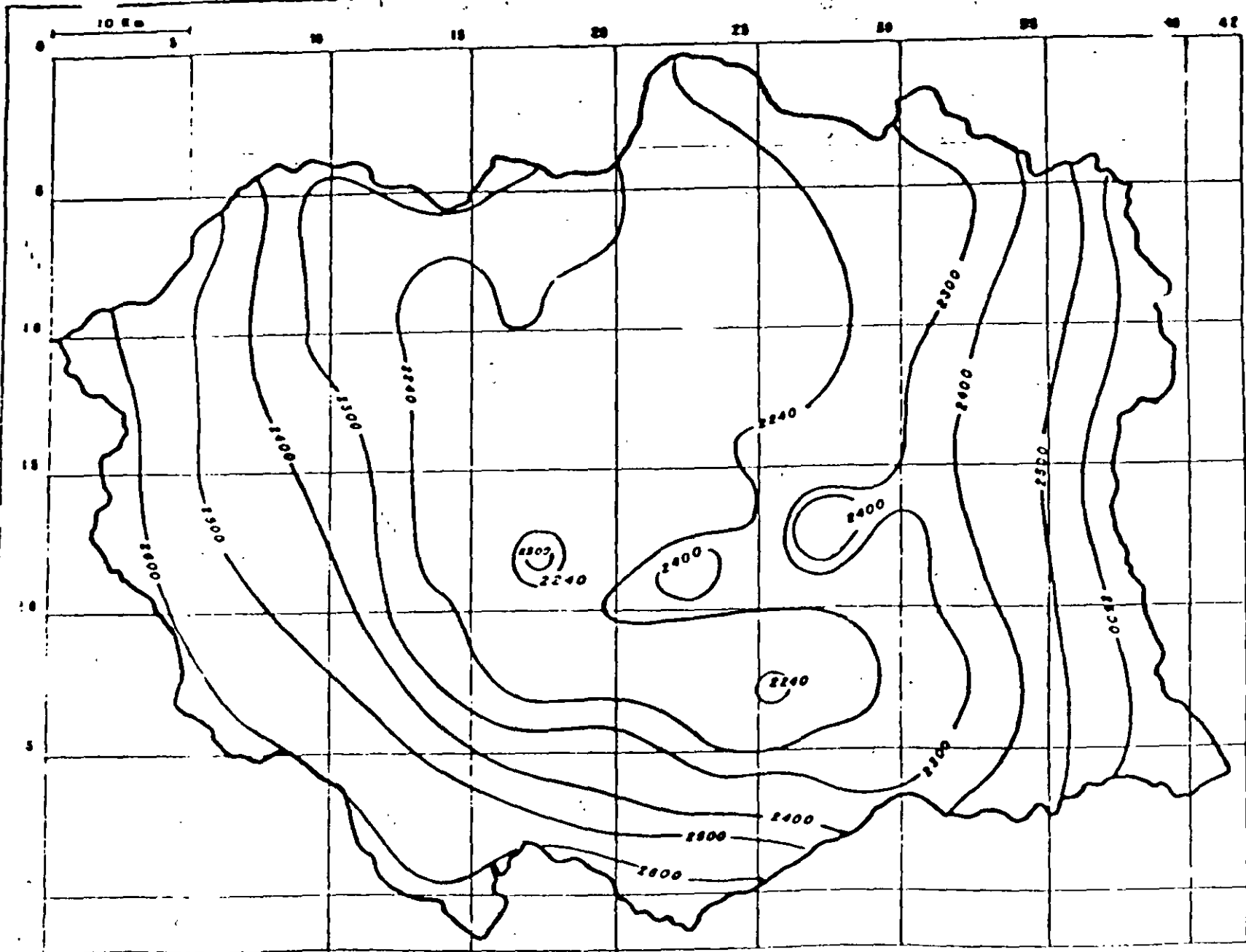

FIG. 8 . ELEVACION INICIAL DEL NIVEL PIEZOMETRICO. m.s.n.m. 1940

INFORMACION BASICA PARA LA IMPLANTACION DE UN MODELO

3.- CONCEPTUALIZACION

- Modelo Conceptual de Funcionamiento.
Definición de Entradas y Salidas.
- Distribución de la Lluvia por Periodos.
Volumen de Lluvia por Celda. Adjudicación
de Coeficientes de Infiltración.
- Cálculo del Caudal de Infiltración.
- Infiltración y/o Drenaje de Rios y Arroyos
Cálculo del Caudal por Celda.
- Definición de Areas de Salidas del Acuífero por
Evapotranspiración.
- Volúmenes de Extracción por pozo.
Cálculo de la Extracción por Celda.
Separación de Extracciones por Riego,
Industrial y Potable. Cálculo de Láminas de
Riego y Retornos al Acuífero.
- Piezometria. Red de flujo en Condiciones
Iniciales, Intermedias y Actuales. Hidrógrafos
de Pozos.
Evoluciones Piezométricas por Periodos.
- Condiciones de Frontera. Definición de Celdas
de no Flujo (inactivas).
Celdas de Carga Constante. Celdas de Carga
Variable. Celdas de Flujo Constante.
Alimentación por Semiconfinamiento.
Otras Celdas.

ACUIFERO CONFINADO

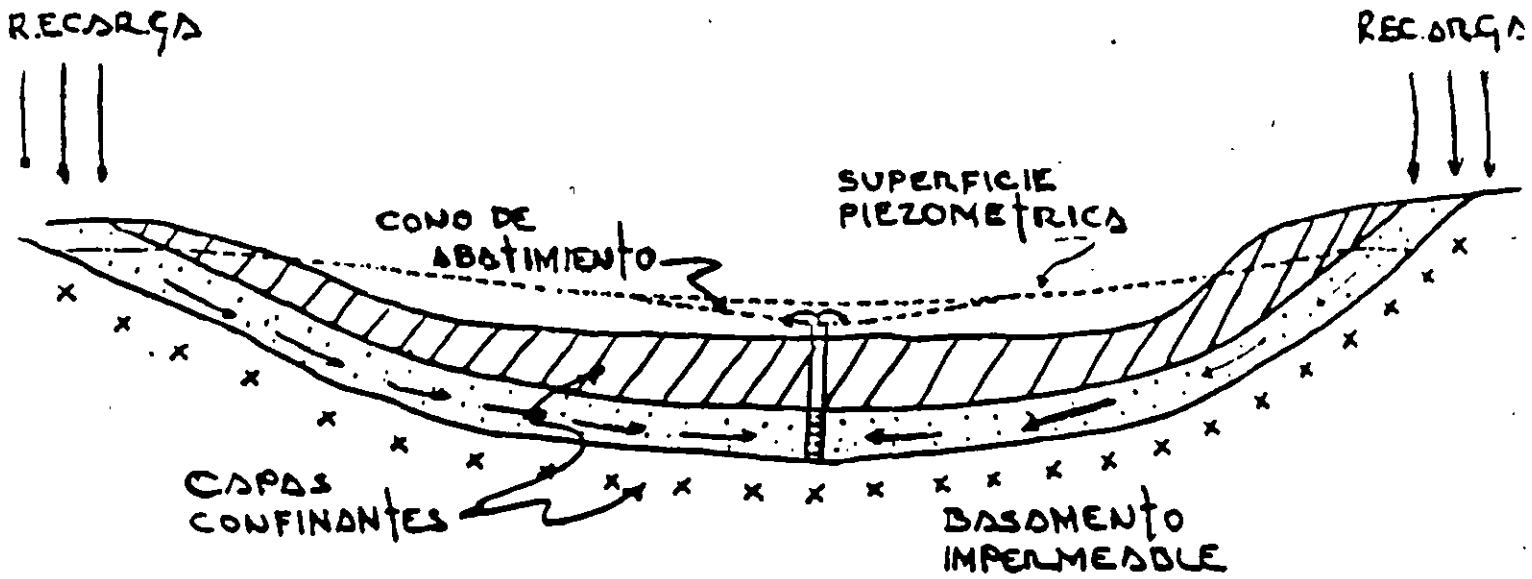

ACUIFERO SEMICONFINADO

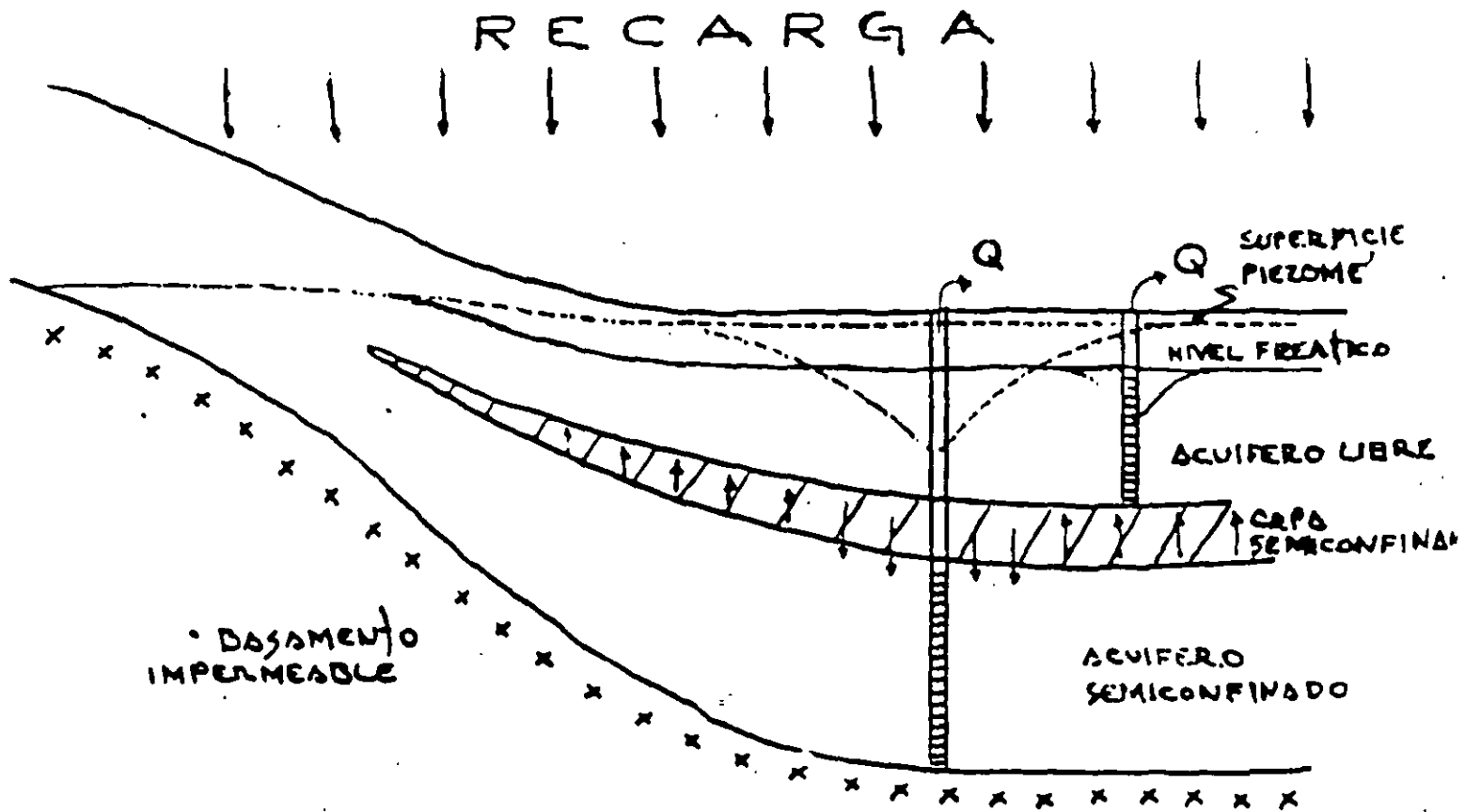

ACUIFERO LIBRE

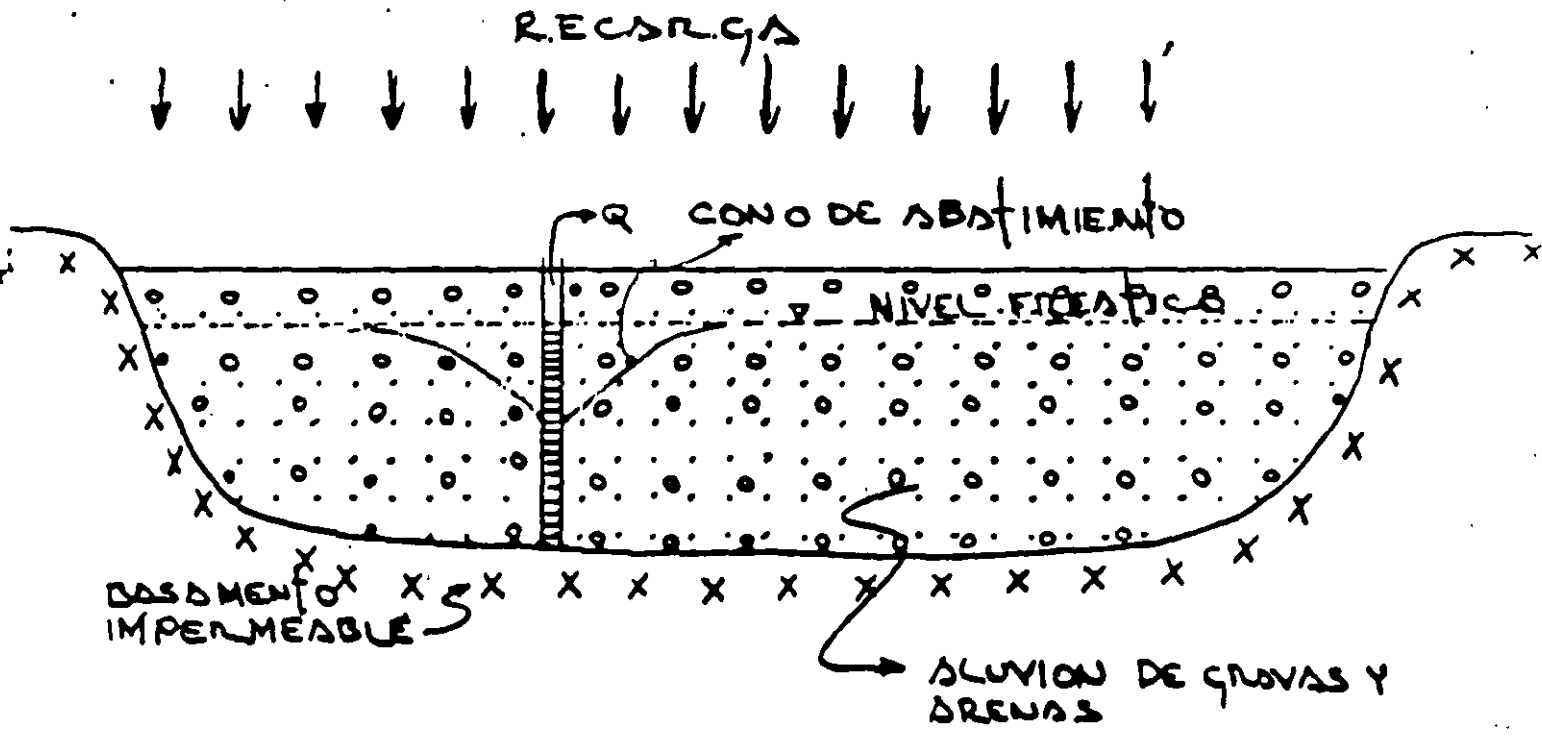

ACUIFEROS MULTIPLES

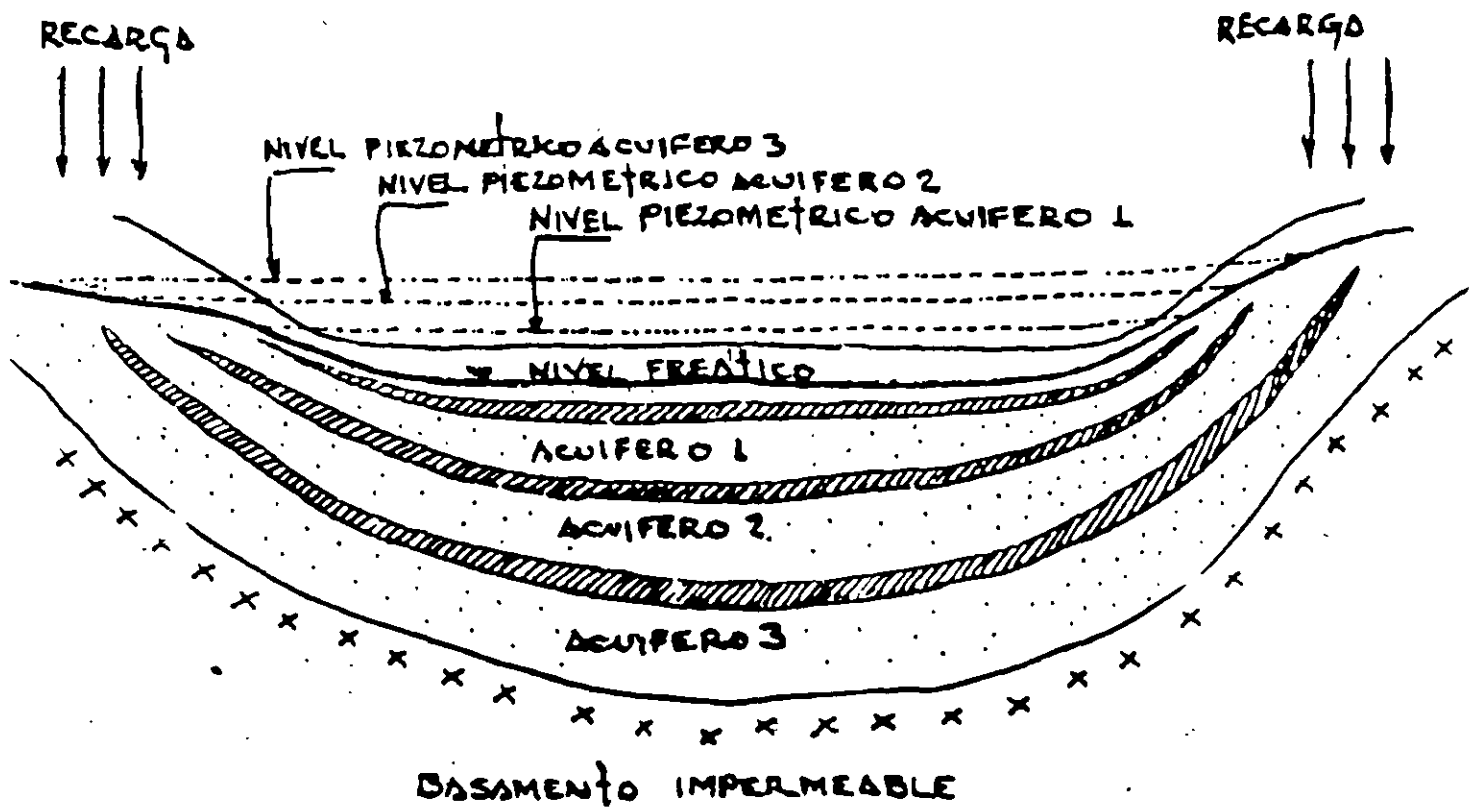

1
2
3
20

1	2190	.45	1																
25	18	0	0	0															
1	1	0	0	.01	900	0	0	0	0	395	0	0							
1	2	0	0	.01	860	0	0	0	0	452	0	0							
1	3	0	0	.01	830	0	0	0	0	450	0	0							
1	4	0	0	.01	800	0	0	0	0	511	0	0							
1	5	931	931	.1	770	-.0001	0	0	0	500	0	0							
1	6	650	650	.1	750	-.0044	0	0	0	500	2	2							
1	7	600	600	.1	730	-.0001	0	0	0	500	2	2							
1	8	500	500	.1	700	-.0001	0	0	0	500	2	2							
1	9	500	500	.1	650	-.0001	0	0	0	500	2	2							
1	10	1000	1000	.20	600	-.0001	0	0	0	400	5	5							
1	11	1000	1000	.20	600	-.0001	0	0	0	450	5	5							
1	12	1150	1150	.2	630	-.0015	0	0	0	390	5	5							
1	13	1000	1000	.2	600	-.0020	0	0	0	300	5	5							
1	14	1000	1000	.25	600	-.0020	0	0	0	420	5	5							
1	15	1200	1200	.25	630	-.0020	0	0	0	410	5	5							
1	16	1200	1200	.25	650	-.0020	0	0	0	410	5	5							
1	17	0	0	.25	650	0	0	0	0	380	0	0							
1	18	0	0	.25	650	0	0	0	0	380	0	0							
2	1	0	0	.01	900	0	0	0	0	395	0	0							
2	2	0	0	.01	860	0	0	0	0	452	0	0							
2	3	0	0	.01	830	0	0	0	0	450	0	0							
2	4	0	0	.01	800	0	0	0	0	511	0	0							
2	5	700	700	.1	770	-.0001	0	0	0	500	0	0							
2	6	650	650	.1	750	-.0044	0	0	0	500	2	2							
2	7	520	520	.1	730	-.0001	0	0	0	500	2	2							
2	8	500	500	.1	700	-.0001	0	0	0	500	2	2							
2	9	500	500	.1	650	-.0001	0	0	0	500	2	2							
2	10	600	600	.2	600	-.00007	0	0	0	450	4	4							
2	11	700	700	.2	590	-.0001	0	0	0	390	4	4							
2	12	1150	1150	.2	600	-.0001	0	0	0	390	5	5							
2	13	1000	1000	.2	580	-.0001	0	0	0	400	5	5							
2	14	1000	1000	.25	560	-.0001	0	0	0	370	5	5							
2	15	1000	1000	.25	590	-.0001	0	0	0	410	5	5							
2	16	2000	2000	.3	600	-.0001	0	0	0	410	10	10							
2	17	2000	2000	.3	600	-.0003	0	0	0	420	10	10							
2	18	0	0	.3	630	0	0	0	0	390	0	0							
3	1	0	0	.01	900	0	0	0	0	395	0	0							
3	2	0	0	.01	860	0	0	0	0	452	0	0							
3	3	0	0	.01	830	0	0	0	0	450	0	0							
3	4	0	0	.01	800	0	0	0	0	511	0	0							
3	5	600	600	.1	770	-.0001	0	0	0	500	0	0							
3	6	500	500	.1	750	-.0044	0	0	0	500	2	2							
3	7	460	460	.1	730	-.0001	0	0	0	500	2	2							
3	8	460	460	.1	700	-.0001	0	0	0	500	2	2							
3	9	500	500	.03	650	-.000004	0	0	0	450	2.5	2.5							
3	10	500	500	.2	600	.0001	0	0	0	400	4	4							
3	11	500	500	.2	585	-.0001	0	0	0	380	4	4							
3	12	700	700	.2	580	-.0001	0	0	0	390	4	4							
3	13	700	700	.25	560	-.0001	0	0	0	390	4	4							
3	14	900	900	.25	550	.0066	0	0	0	348	4.5	4.5							
3	15	1000	1000	.25	550	-.0001	0	0	0	410	5	5							
3	16	2000	2000	.3	555	-.0001	0	0	0	380	10	10							
3	17	2000	2000	.35	560	-.0051	0	0	0	390	10	10							

ACUIFERO PARCIALMENTE CONFINADO

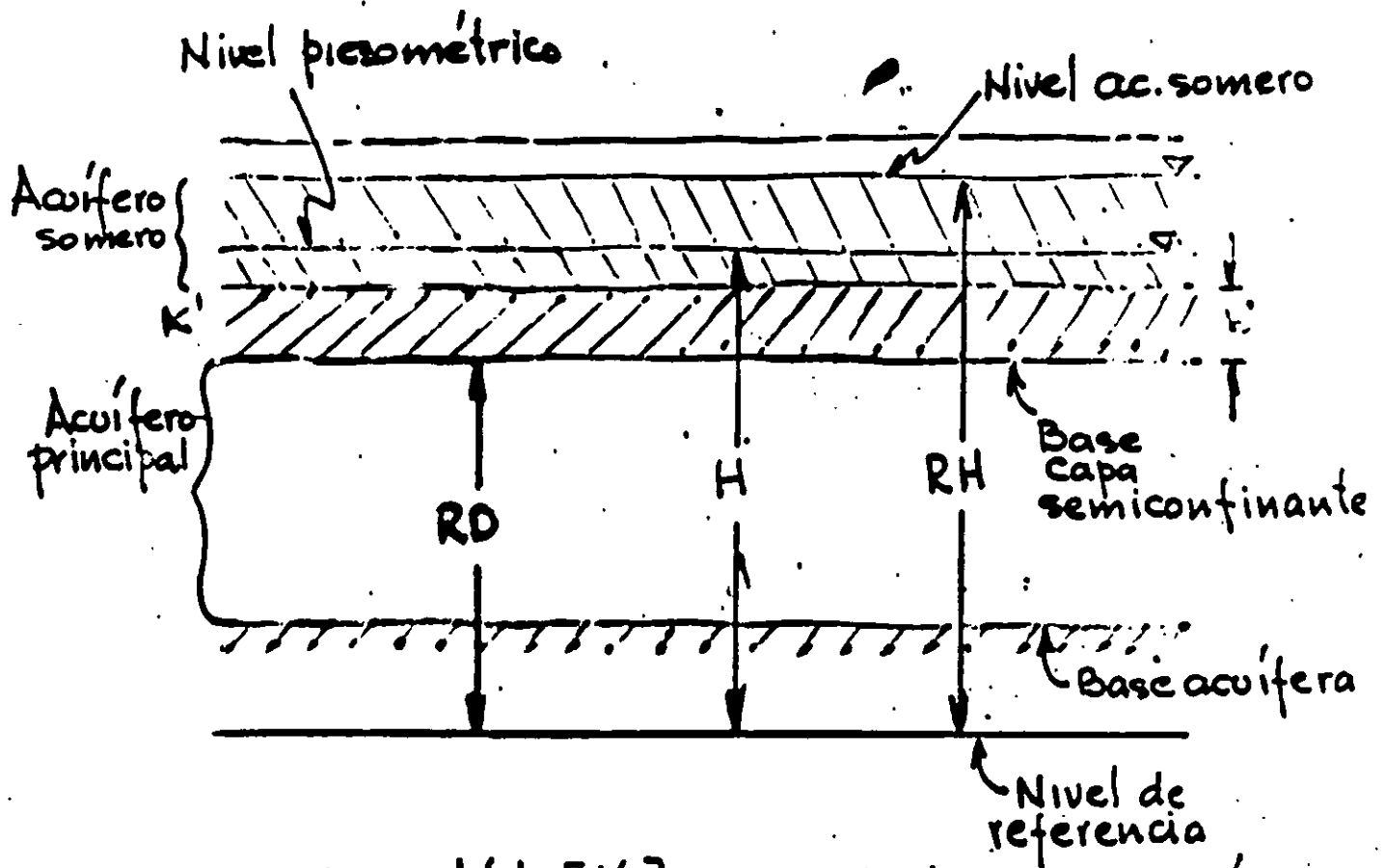

$$R = k'/b' \text{ [1/d]} \text{ Coeficiente de filtración}$$

Filtración vertical: F

$$F = R \cdot (H - R_H) , H > R_D$$

$$F = R \cdot (R_D - R_H) = \text{cte} , H < R_D$$

EVAPOTRANSPIRACION

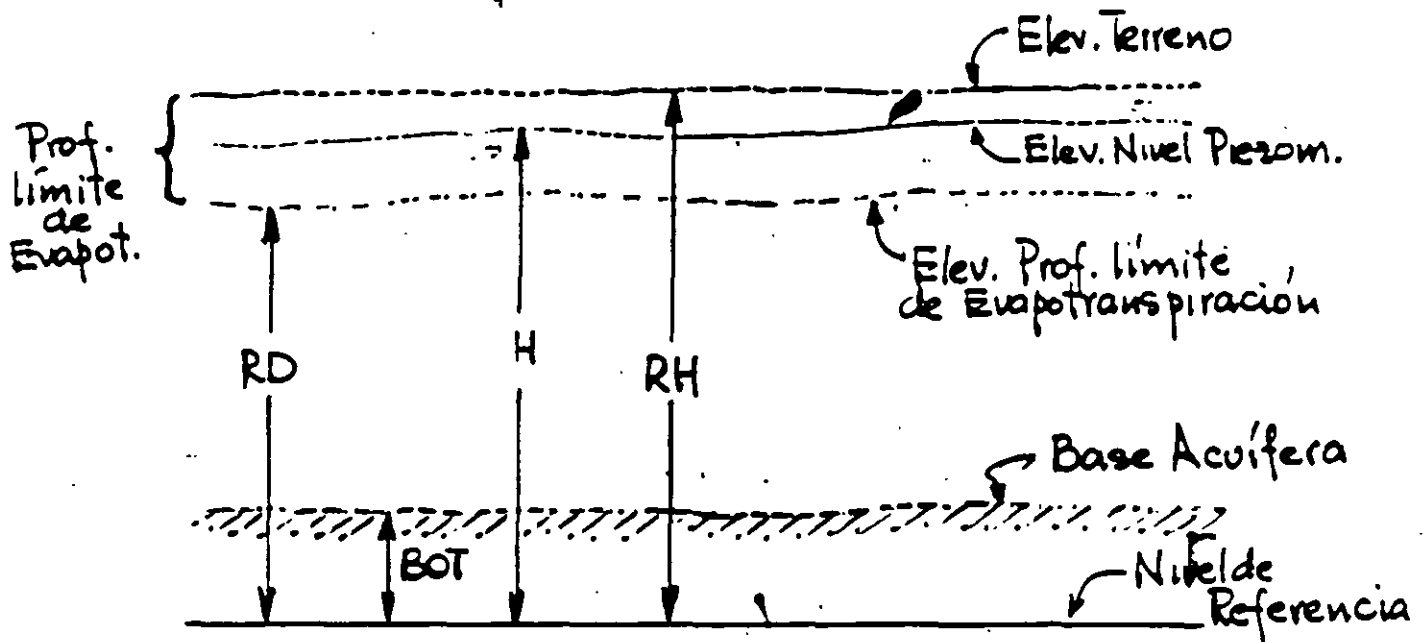

$$R = \frac{\text{Evap. med. diaria (m)/d}}{\text{Prof. límite de Evapot. (m)}} = \left[\frac{1}{d} \right]$$

$$\text{Evap. media diaria} = \text{Evap. anual} \times 0.75 / 365d$$

Arreglo Columnas Archivo

I, J, TI, TJ, SC, H, Q, R, RH, RD, BOT, PERMI, PERMJ
 ↑ ↑ ↑ ↑

$$Q = \text{Evap. media diaria (m/d)} + \text{Extracción - Recarga}$$

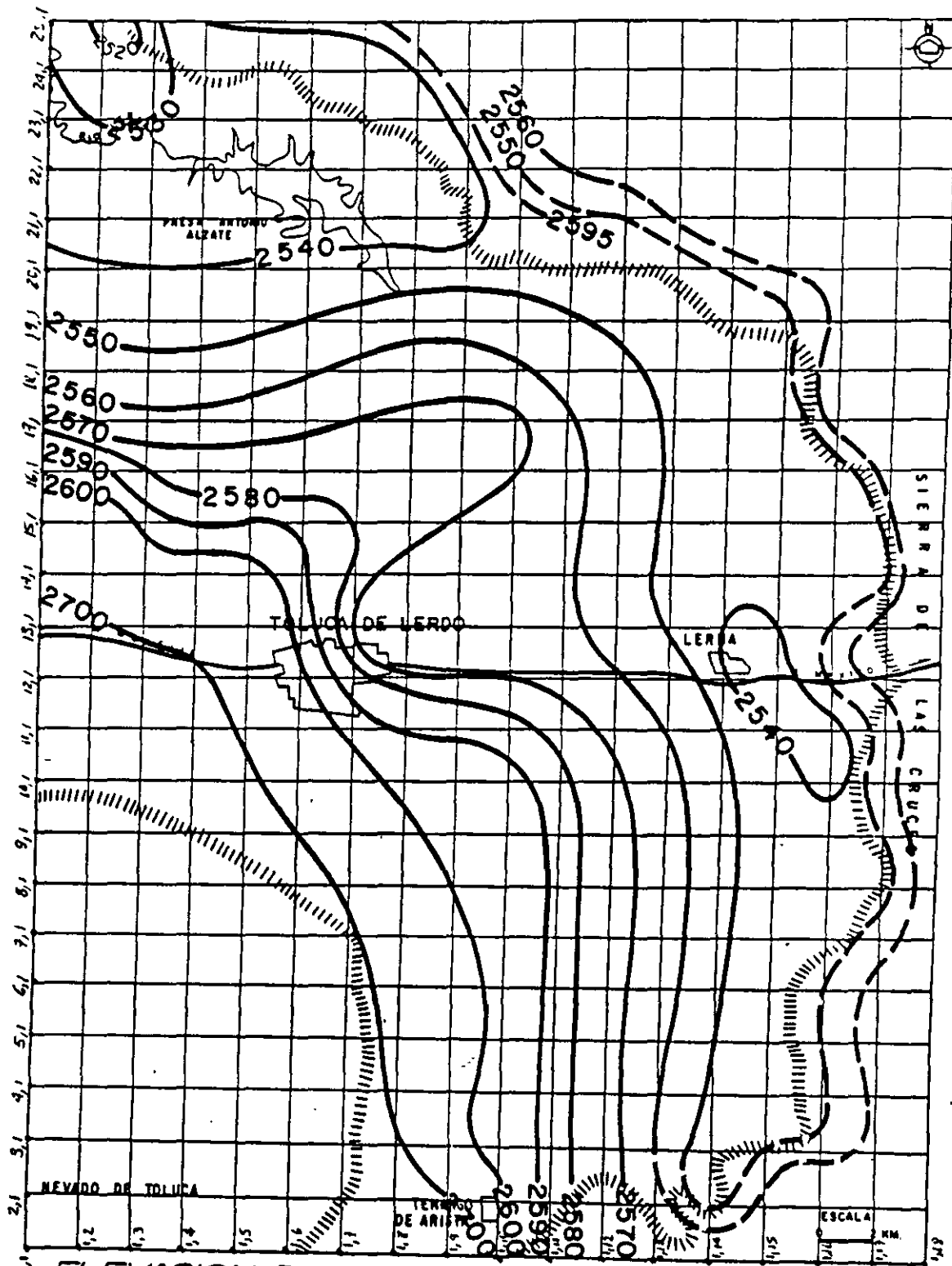

ELEVACION DEL NIVEL ESTATICO OBSERVADA
 PARA EL AÑO DE 1991 EN METROS SOBRE EL
 NIVEL DEL MAR

FIGURA 8.8

TOLUCA 10

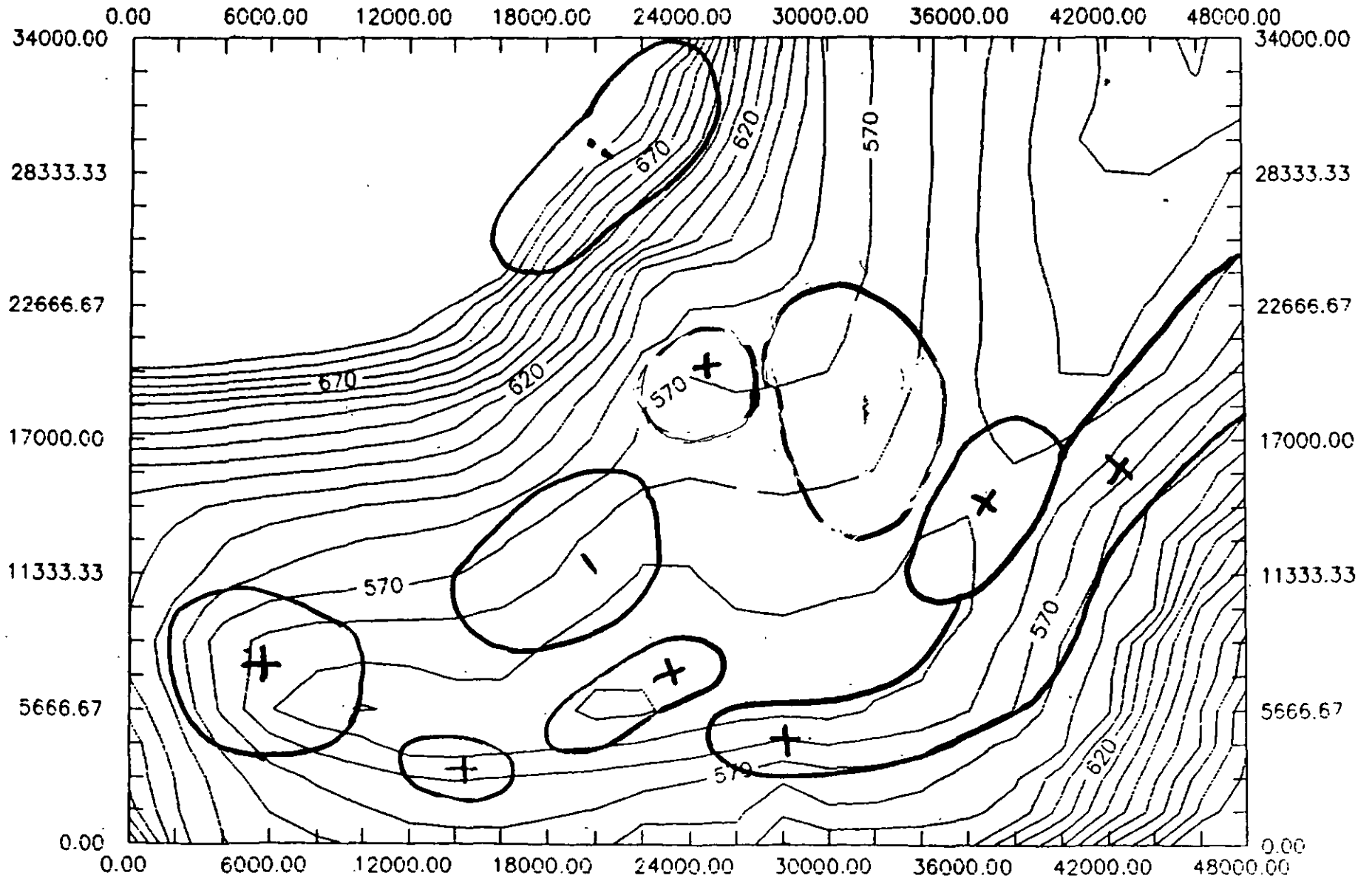



FIGURA 8.2



FIGURA 8.3

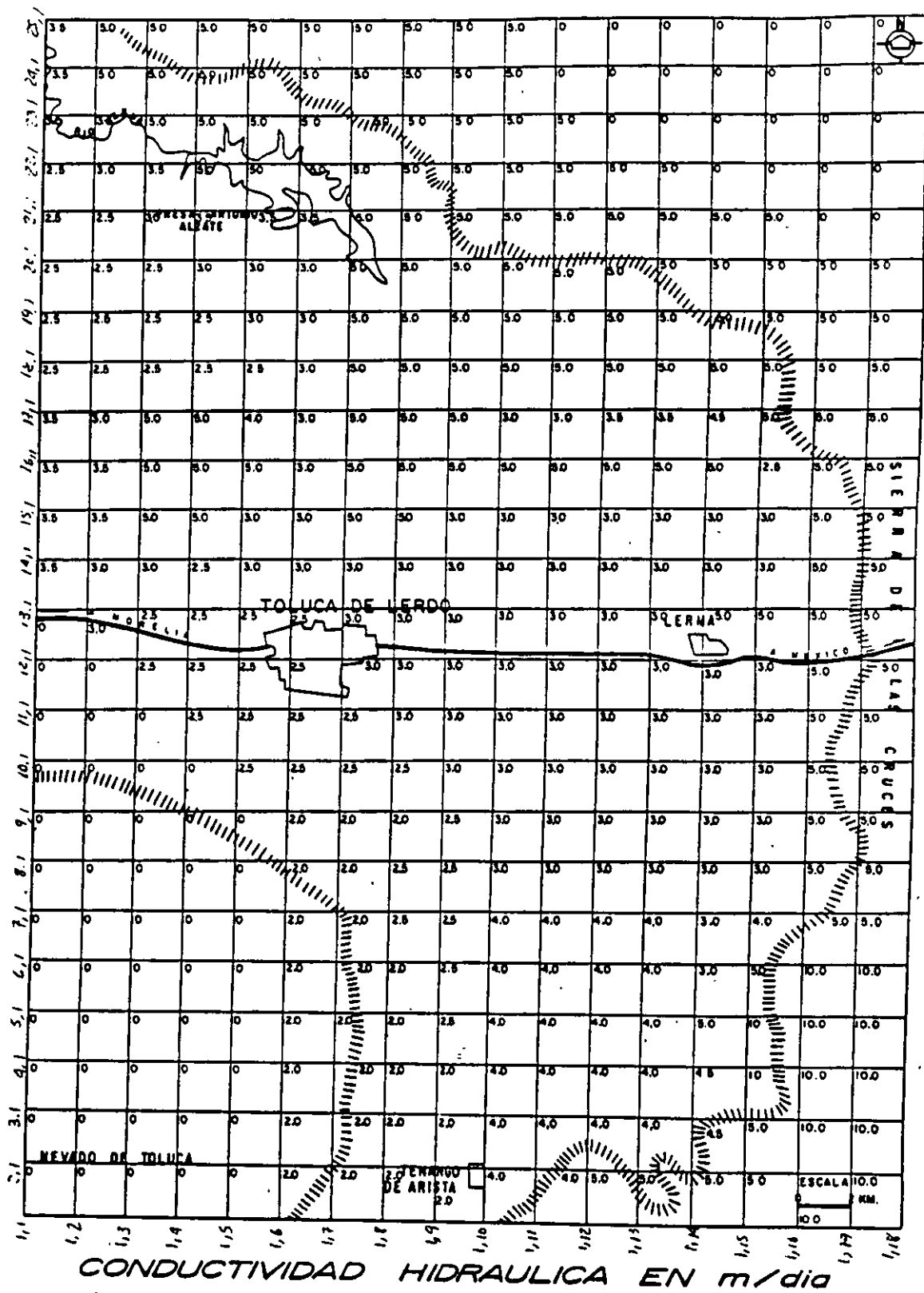

FIGURA 8.6

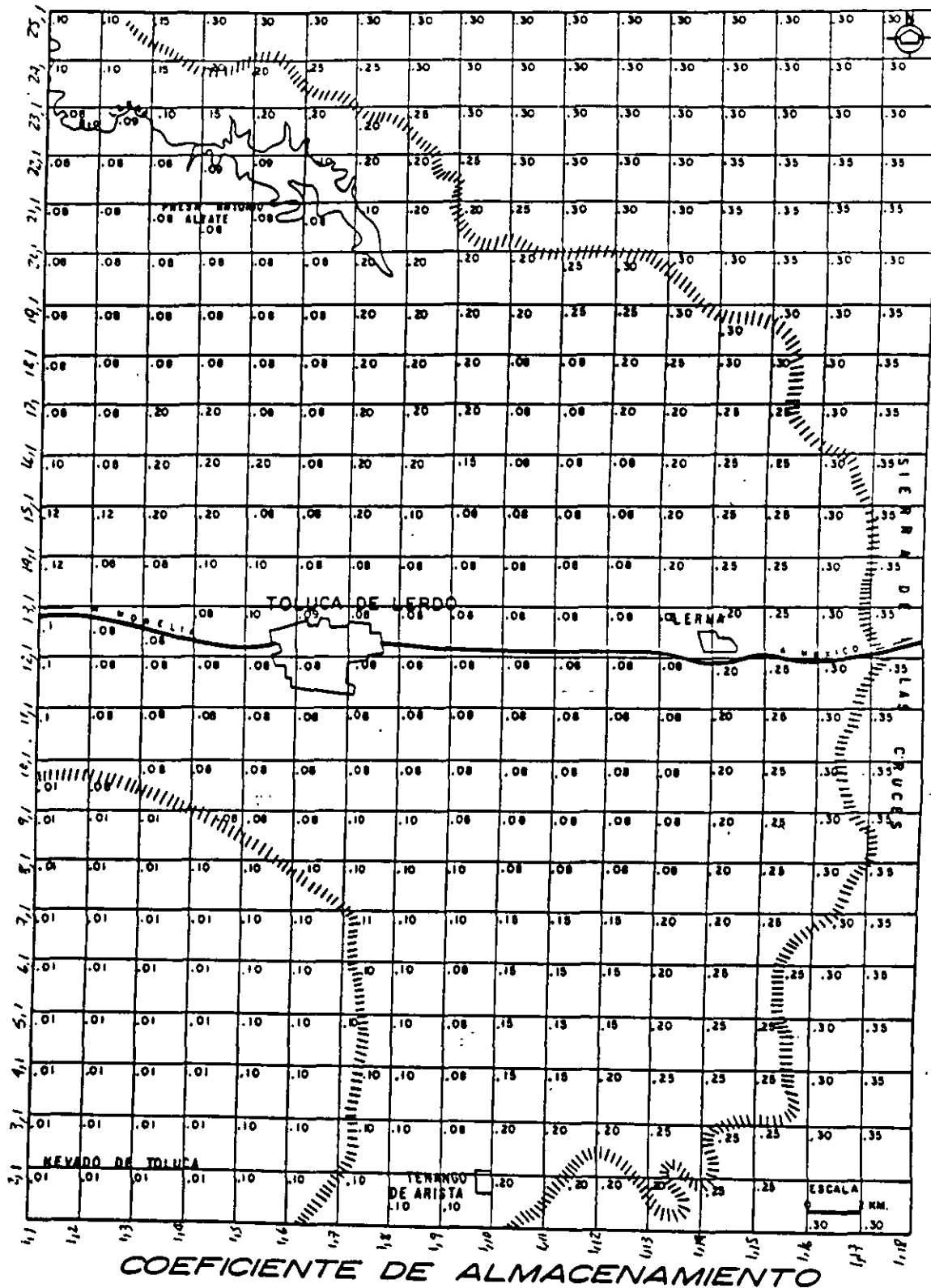

**FACULTAD DE INGENIERIA U.N.A.M.
DIVISION DE EDUCACION CONTINUA**

CURSOS ABIERTOS

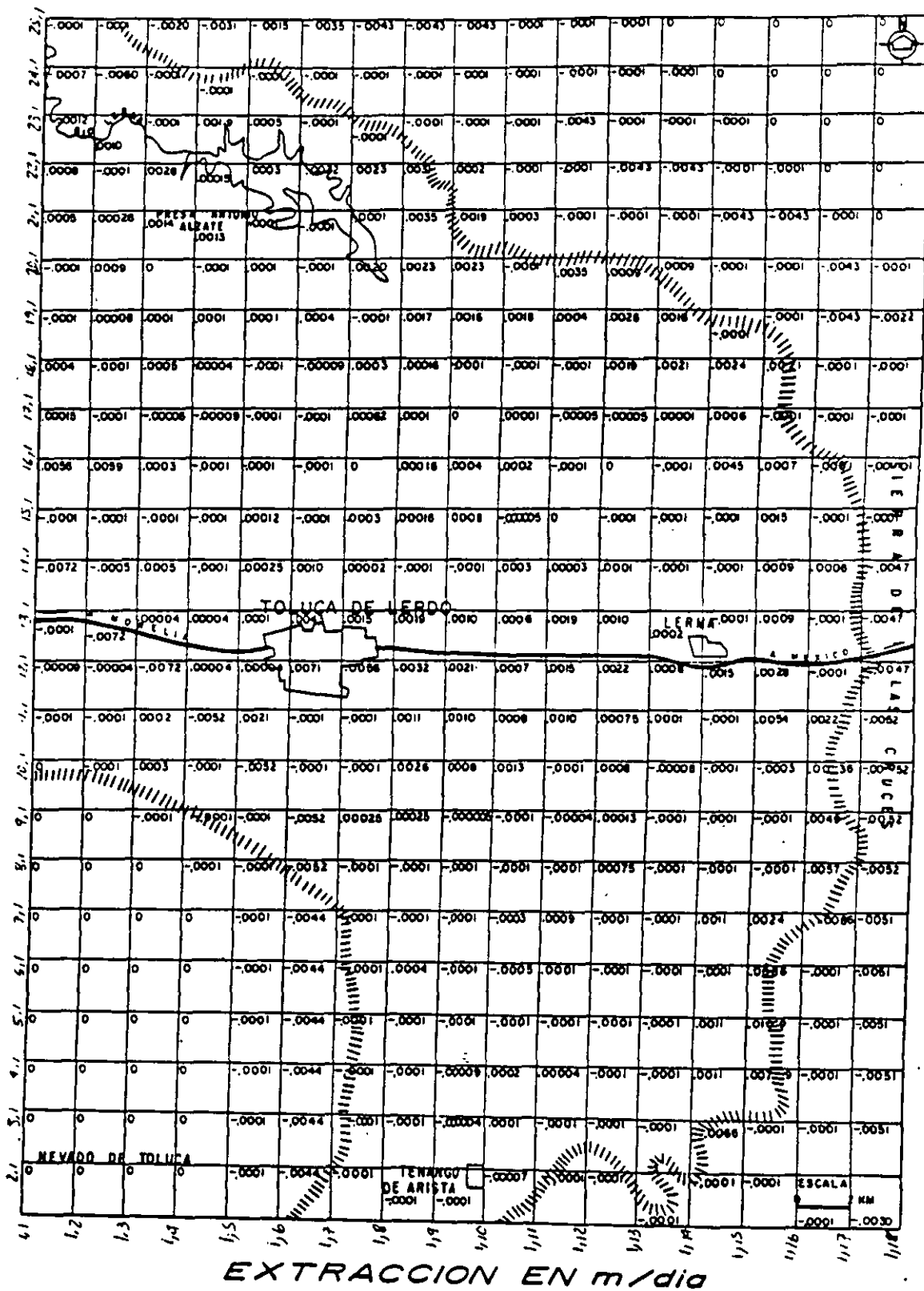
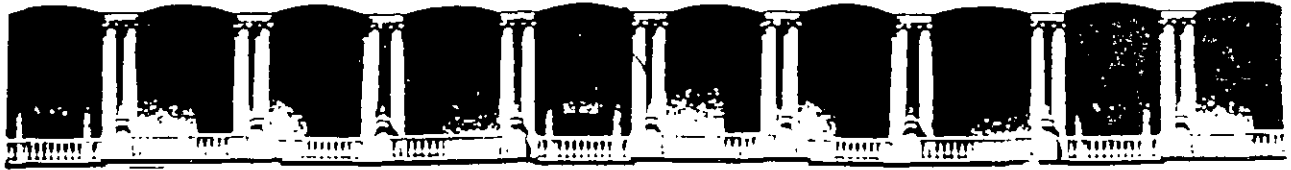
**“ IX CURSO INTERNACIONAL DE
CONTAMINACIÓN DE ACUÍFEROS “**

MODULO III

MODELOS MATEMÁTICOS EN GEOHIDROLOGÍA

TEMA

**SIMULACIÓN COMPUTACIONAL DE
FLUJO EN MEDIOS POROSOS**

**EXPOSITOR: PROF. RODRIGO MEDINA BAÑUELOS
1997**

SIMULACION COMPUTACIONAL DE FLUJO EN MEDIOS

POROSOS SATURADOS

RODRIGO MEDINA BAÑUELOS

UNIVERSIDAD NACIONAL AUTONOMA DE MEXICO

INSTITUTO DE GEOFISICA

CIRCUITO EXTERIOR, C.U.

04510 MEXICO, D.F.

Tel: 622-41-31 o 622-41-33

Fax: 550-24-86

SIMULACION COMPUTACIONAL DE FLUJO EN MEDIOS POROSOS SATURADOS

Rodrigo Medina Bañuelos

Introducción:

El análisis del comportamiento observado de un acuífero, y la predicción de su evolución futura, son objetivos importantes que se pretende alcanzar mediante una serie de estudios multidisciplinarios que permiten simular el movimiento del agua en medios porosos.

La implementación de un modelo numérico de simulación requiere de información proveniente de diversas disciplinas. Los resultados proporcionados por estudios geológicos, geofísicos, hidrogeoquímicos, hidráulicos, climatológicos, etc. constituyen los archivos de datos que caracterizan al acuífero estudiado.

La metodología que se emplea en el proceso de modelación numérica, consiste en obtener una solución aproximada de la ecuación diferencial que gobierna el movimiento del agua en un medio poroso saturado. La región de simulación se define de acuerdo a la geometría del sistema acuífero estudiado, y se le imponen condiciones de frontera justificables por la geología y la hidráulica subterránea. Adicionalmente, para la solución transitoria se requiere de condiciones iniciales (observadas o deducidas) para el tiempo de inicio de la simulación.

Una vez que se dispone de los archivos de datos, el algoritmo numérico de solución de la ecuación de flujo, condiciones iniciales y de frontera especificados, se procede a ejecutar las simulaciones de calibración del sistema, enfocadas a reproducir el comportamiento observado. La incertidumbre en los valores asignados a los parámetros hidráulicos y a la recarga del sistema, entre otros factores, pueden conducir a una discrepancia entre los niveles piezométricos observados y los simulados. La calibración del modelo consiste en modificar los archivos de datos propuestos originalmente, hasta obtener un funcionamiento del sistema que sea similar al observado históricamente.

Las simulaciones predictivas se realizan utilizando los archivos de datos calibrados y permiten prever el comportamiento que el sistema acuifero adoptará en el futuro al ser sometido a diversas políticas de explotación.

Las configuraciones de niveles piezométricos obtenidas mediante simulaciones predictivas, son determinantes en la toma de decisiones para el manejo racional de los recursos hidráulicos y para el diseño de las estructuras requeridas.

En los subcapítulos siguientes se presentan algunos aspectos importantes del proceso de simulación numérica, entre estos la deducción de la ecuación diferencial que describe el movimiento del agua en medios porosos, algunos comentarios acerca de los problemas con valores a la frontera, un ejemplo del procedimiento de solución analítica de un problema con valores a la frontera, y finalmente un artículo referente a la simulación numérica del acuifero de San Luis Potosí que ilustra concretamente la metodología expuesta.

DEDUCCION DE LA ECUACION DIFERENCIAL DE FLUJO EN MEDIOS POROSOS

La deducción de la ecuación de flujo para un medio poroso saturado se puede realizar mediante un balance de materia en un volumen de control:

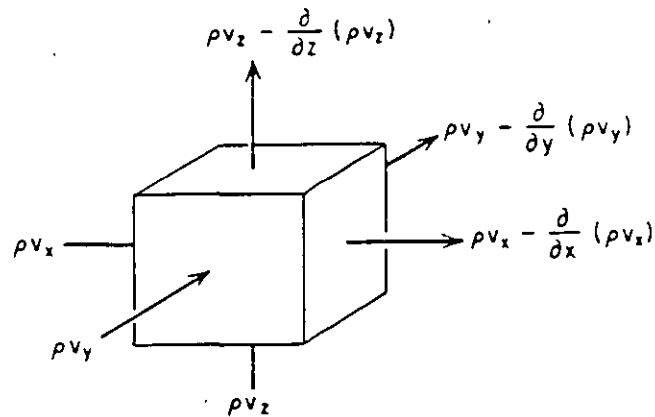

Según la ecuación de continuidad (Ley de Conservación de la Materia), las entradas (E) menos las salidas (S) en un sistema, son iguales al cambio de volumen almacenado dentro del mismo (ΔV).

$$E - S = \Delta V$$

La masa que pasa por unidad de tiempo a través de una cara del volumen de control $\left(\frac{M}{L^2 T} \right)$ se puede expresar como $\rho v A$

donde: $\rho = \text{Densidad del fluido} \left(\frac{M}{L^3} \right)$

$v = \text{Descarga específica} \left(\frac{L}{T} \right)$

Las entradas menos las salidas en la dirección x serán:

$$\rho v_x \Delta y \Delta z - \left[\rho v_x + \frac{\partial(\rho v_x)}{\partial x} \Delta x \right] \Delta y \Delta z$$

Análogamente:

en la dirección y:

$$\rho v_y \Delta x \Delta z - \left[\rho v_y + \frac{\partial(\rho v_y)}{\partial y} \Delta y \right] \Delta x \Delta z$$

en la dirección z:

$$\rho v_z \Delta x \Delta y - \left[\rho v_z + \frac{\partial(\rho v_z)}{\partial z} \Delta z \right] \Delta x \Delta y$$

Las entradas menos las salidas en el volumen de control serán:

$$E - S = - \left[\frac{\partial(\rho v_x)}{\partial x} + \frac{\partial(\rho v_y)}{\partial y} + \frac{\partial(\rho v_z)}{\partial z} \right] \Delta x \Delta y \Delta z$$

Dividiendo entre el volumen $\Delta x \Delta y \Delta z$, se obtiene el cambio en el almacenamiento por unidad de volumen del sistema:

$$\Delta V = - \left[\frac{\partial(\rho v_x)}{\partial x} + \frac{\partial(\rho v_y)}{\partial y} + \frac{\partial(\rho v_z)}{\partial z} \right] \quad (1)$$

Para un sistema en estado estacionario la variación del volumen almacenado con respecto al tiempo (Δv) es igual a cero:

$$\Delta V = 0$$

Suponiendo densidad del fluido constante:

$$- \left[\frac{\partial v_x}{\partial x} + \frac{\partial v_y}{\partial y} + \frac{\partial v_z}{\partial z} \right] \cong 0 \quad (2)$$

Sustituyendo la ecuación de Darcy:

$$v = - K \frac{\partial h}{\partial L} \quad \text{en cada componente}$$

$$\frac{\partial}{\partial x} \left(K_x \frac{\partial h}{\partial x} \right) + \frac{\partial}{\partial y} \left(K_y \frac{\partial h}{\partial y} \right) + \frac{\partial}{\partial z} \left(K_z \frac{\partial h}{\partial z} \right) = 0 \quad (3)$$

Suponiendo que el material es isotrópico ($K_x = K_y = K_z$) y homogéneo ($K = \text{cte}$).

$$\frac{\partial^2 h}{\partial x^2} + \frac{\partial^2 h}{\partial y^2} + \frac{\partial^2 h}{\partial z^2} = 0 \quad (4)$$

Esta ecuación es conocida como la Ecuación de Laplace y es de gran utilidad en hidrogeología. La solución de esta ecuación describe el valor de la carga hidráulica en estado estacionario en cualquier punto en una región tridimensional.

Flujo transitorio en medio saturado.

La ley de conservación de masa requiere que la masa que se almacena por unidad de tiempo por unidad de volumen dentro del volumen de control, sea igual a la variación con respecto al tiempo de la densidad ρ del fluido que se encuentra dentro de los poros del material limitado por el volumen de control

$$- \left[\frac{\partial(\rho vx)}{\partial x} + \frac{\partial(\rho vy)}{\partial y} + \frac{\partial(\rho vz)}{\partial z} \right] = \frac{\partial(\rho n)}{\partial t} \quad (5)$$

donde n es la porosidad del material.

Desarrollando el lado derecho de la ecuación.

$$- \left[\frac{\partial(\rho vx)}{\partial x} + \frac{\partial(\rho vy)}{\partial y} + \frac{\partial(\rho vz)}{\partial z} \right] = n \frac{\partial \rho}{\partial t} + \rho \frac{\partial n}{\partial t} \quad (6)$$

$n \frac{\partial \rho}{\partial t}$ es la masa producida por la expansión del agua por unidad

de tiempo cuando cambia su densidad.

$\rho \frac{\partial n}{\partial t}$ es la masa producida por la compactación del medio poroso

por unidad de tiempo cuando cambia su porosidad.

Se puede demostrar que el cambio en ρ y el cambio en n se producen al variar la carga hidráulica h , y que el volumen de agua producido por los 2 mecanismos cuando la carga hidráulica h disminuye una unidad, es S_s (coeficiente de almacenamiento específico [L^{-1}])

$$S_s = \rho g(\alpha + n\beta) \quad (7)$$

α = compresibilidad de la matriz sólida

β = compresibilidad del fluido

El cambio de masa de fluido almacenado por unidad de tiempo es:

$$\Delta V = \rho S_s \frac{\partial h}{\partial t} \quad (8)$$

La ecuación (6) se puede expresar como:

$$-\frac{\partial(\rho v_x)}{\partial x} - \frac{\partial(\rho v_y)}{\partial y} - \frac{\partial(\rho v_z)}{\partial z} = \rho S_s \frac{\partial h}{\partial t} \quad (9)$$

Desarrollando los términos del lado izquierdo por medio de la regla de la cadena, y considerando que los términos $\rho \frac{\partial v_x}{\partial x}$ son mucho mayores que los $v_x \frac{\partial \rho}{\partial x}$, y sustituyendo la Ley de Darcy, se obtiene:

$$\frac{\partial}{\partial x} \left(K_x \frac{\partial h}{\partial x} \right) + \frac{\partial}{\partial y} \left(K_y \frac{\partial h}{\partial y} \right) + \frac{\partial}{\partial z} \left(K_z \frac{\partial h}{\partial z} \right) = S_s \frac{\partial h}{\partial t} \quad (10)$$

Considerando medio isótropo: $K_x = K_y = K_z$

$$\frac{\partial^2 h}{\partial x^2} + \frac{\partial^2 h}{\partial y^2} + \frac{\partial^2 h}{\partial z^2} = \frac{S_s}{K} \frac{\partial h}{\partial t} \quad (11)$$

$$\frac{\partial^2 h}{\partial x^2} + \frac{\partial^2 h}{\partial y^2} + \frac{\partial^2 h}{\partial z^2} = \frac{S}{T} \frac{\partial h}{\partial t} \quad (12)$$

Esta ecuación se conoce como la ecuación de difusión. La solución $h(x,y,z,t)$ describe el valor de la carga hidráulica en cualquier punto (x,y,z) de la región para cualquier tiempo t .

Problemas con valores a la frontera

Un problema de valores a la frontera es un modelo matemático

La técnica de análisis de un problema de valores a la frontera es un proceso de 4 pasos:

- 1) Examen del problema físico
- 2) Planteamiento del problema físico en términos de un problema matemático equivalente
- 3) Solución del problema matemático con técnicas matemáticas
- 4) Interpretación de los resultados matemáticos en términos del problema físico.

Los problemas de flujo en medios porosos dan lugar a un problema matemático de la forma de problema con valores a la frontera.

Para definir completamente un problema transitorio de valores a la frontera en flujo subterráneo se necesita conocer:

- 1) El tamaño y forma de la región de flujo (geometría del sistema)
- 2) La ecuación de flujo dentro de la región
- 3) Las condiciones de frontera alrededor de la región
- 4) Las condiciones iniciales en la región
- 5) La distribución espacial de los parámetros hidrogeológicos que controlan el flujo
- 6) Un método matemático de solución

Si el problema con valores a la frontera es para estado estacionario, no se requiere conocer las condiciones iniciales del sistema.

Los métodos de solución para un problema con valores a la frontera pueden ser clasificados en 5 enfoques:

- 1) Solución por inspección
- 2) Solución por técnicas gráficas (redes de flujo)
- 3) Solución por modelos analógicos (circuitos eléctricos)
- 4) Solución por técnicas matemáticas analíticas
- 5) Solución por técnicas matemáticas numéricas (modelos computacionales)

Ejemplo de una solución analítica a un problema de valores a la frontera

Considere el problema de flujo subterráneo mostrado en las figuras:

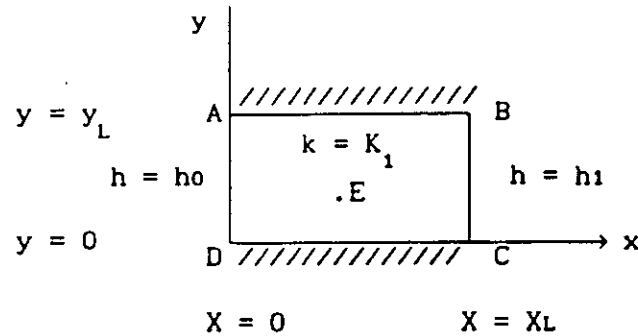

La ecuación de flujo en dos dimensiones para flujo en zona saturada y estado estacionario es:

$$\frac{\partial^2 h}{\partial x^2} + \frac{\partial^2 h}{\partial y^2} = 0 \quad \text{--- (1)}$$

La expresión matemática de las condiciones de frontera es:

$$\frac{\partial h}{\partial y} = 0 \quad \text{en} \quad y = 0 \quad \text{y} \quad y = y_L \quad \text{--- (2)}$$

$$h = h_0 \quad \text{en} \quad X = 0 \quad \text{--- (3)}$$

$$h = h_1 \quad \text{en} \quad X = X_L \quad \text{--- (4)}$$

Se obtendrá $h(x,y)$ usando la técnica de separación de variables:

Se supone en el método de separación de variables que la solución es un producto de la forma:

$$h(x,y) = X(x) Y(y) \quad \text{--- (5)}$$

La ecuación (1) se expresa ahora como:

$$Y \frac{\partial^2 X}{\partial x^2} + X \frac{\partial^2 Y}{\partial y^2} = 0 \quad \text{--- (6)}$$

Dividiendo entre X Y se obtiene:

$$\frac{1}{X} \frac{\partial^2 X}{\partial x^2} = - \frac{1}{Y} \frac{\partial^2 Y}{\partial y^2} \quad - - - (7)$$

El lado izquierdo es independiente de y. El lado derecho, a pesar de su apariencia, debe ser independiente de y, debido a que es igual al lado izquierdo. Análogamente, el lado derecho es independiente de x, y también el lado izquierdo. Si los dos términos de la ecuación son independientes de x y y, cada término debe ser igual a una constante.

entonces:

$$\frac{1}{X} \frac{\partial^2 X}{\partial x^2} = G \quad y \quad \frac{1}{Y} \frac{\partial^2 Y}{\partial y^2} = G \quad - - - (8)$$

La constante G puede ser positiva, negativa o cero. Los 3 casos conducen a una solución tipo producto. Pero sólo el caso $G = 0$ dá lugar a una solución que tiene significado físico para este problema. Por lo tanto:

$$\frac{1}{X} \frac{\partial^2 X}{\partial x^2} = 0 \quad y \quad \frac{1}{Y} \frac{\partial^2 Y}{\partial y^2} = 0 \quad - - - (9)$$

Estas son ecuaciones diferenciales ordinarias cuyas soluciones son bien conocidas:

$$X = Ax + B \quad y \quad Y = Cy + D \quad - - - (10)$$

La solución producto (5) es:

$$h(x,y) = (Ax + B)(Cy + D) \quad - - - (11)$$

Los coeficientes A, B, C y D se evalúan mediante las condiciones de frontera. Diferenciando (11) con respecto a y se obtiene:

$$\frac{\partial h}{\partial y} = (Ax + B)C \quad - - - (12)$$

La condición de frontera (2) implica que $C = 0$. La ecuación (11) queda como:

$$h(x,y) = (Ax + B)D = Ex + F \quad - - - (13)$$

De acuerdo a las condiciones de frontera (3) y (4);

$F = h_0$ y $E = -(h_0 - h_1)/xL$. La solución es entonces:

$$h(x,y) = h_0 - (h_0 - h_1) \frac{x}{xL} \quad - - - (14)$$

Se aprecia claramente que la ecuación (14) satisface las condiciones de frontera (3) y (4). La derivada con respecto a y es igual a cero satisfaciendo la condición (2). La segunda derivada de $h(x,y)$ con respecto a x también es igual a cero. Por lo tanto la solución (14) satisface la ecuación de flujo (1).

Bibliografía:

Domenico, P. and Schwartz F., 1990, Physical and Chemical Hydrogeology: John Wiley and Sons, Inc.

Freeze, R. A., and Cherry, J. A., 1979, Groundwater: Englewood Cliffs, N.J., Prentice Hall, 604 p.

Remson, I., Hornberger, G.M., and Molz, F.J., 1971, Numerical Methods in Subsurface Hydrology: New York, Wiley-Interscience.

Wang, H.F., and Anderson, M.P., 1982, Introduction to Groundwater Modeling-Finite Difference and Finite Element Methods. San Francisco, W.H. Freeman.

1992

SERIE DE INVESTIGACION N° 145
(PREIMPRESOS)

EVALUATION OF HYDROTHERMAL SOURCES THAT
SUSTAIN AN OVEREXPLOITED AQUIFER AT
SAN LUIS POTOSI, MEXICO.

I. HERRERA, R. MEDINA, L. CHARGOY and
J. CARRILLO.

Recibido: 30 de junio de 1992

Instituto de Geofísica, UNAM.
Ciudad Universitaria
Delegación Coyoacán
04510 México, D.F.

Contribución IGF N° PA -1992 - 7
Aceptado para publicación en:
Selected Papers Vol.3 del XIII
Congreso Internacional de la In-
ternational Association of Hy-
drogeologists.

Precio: \$2,000.-

EVALUATION OF HYDROTHERMAL SOURCES THAT SUSTAIN AN OVEREXPLOITED AQUIFER AT SAN LUIS POTOSI, MEXICO.

I. HERRERA, R. MEDINA, L. CHARGOY & J. CARRILLO
Instituto de Geofísica, UNAM, Mexico City
Apdo. Postal 22-582, 14000 Mexico, D.F., Mexico

ABSTRACT. A numerical model is implemented for the aquifer of the City of San Luis Potosi, which takes into account the contribution of an underlying thermal source. Previously, it was thought to be overexploited. By means of the numerical model, it is shown that this is not the case, because there is a contribution from the underlying thermal source. Since the properties of the thermal source are not known, the procedure used to incorporate them is to adjust the values of the vertical hydraulic conductivity between the thermal source and the aquifer until the actual piezometric levels in the aquifer were reproduced. For this case study, such a procedure has produced useful results.

INTRODUCTION

The Valley of San Luis Potosi, is located in the high plateau of the Republic of Mexico (Fig.1) and it lies in the semi-arid region. The water demand of the City of San Luis Potosi, capital of the state of the same name, for agricultural, urban and industrial uses, has been steadily increasing. Most of the water supplied to the city is from underground sources, because due to the reduced rainfall, the surface water contribution is small (only 8 %).

There is concern with respect to the future evolution of the aquifer, because in the last few years the observed speed of drawdown has reached the rate of 1.3 m year^{-1} . However, if the hydraulic balance of the aquifer is carried out taking into account only what is known about the aquifer, the predicted rate of drawdown is even larger. On the basis of thermal, chemical and hydraulic evidences, in a previous study: Instituto de Geofísica, UNAM (1988), it was established that the differences between the observed and the predicted rate of drawdown is due, to water supplied by deeper geological formations with thermal activity.

Taking into account these facts, it was decided to implement a numerical model of the aquifer to improve the understanding of its behavior, specially with respect to the deep thermal sources, and to predict the system behavior under different exploitation policies for the next twenty years.

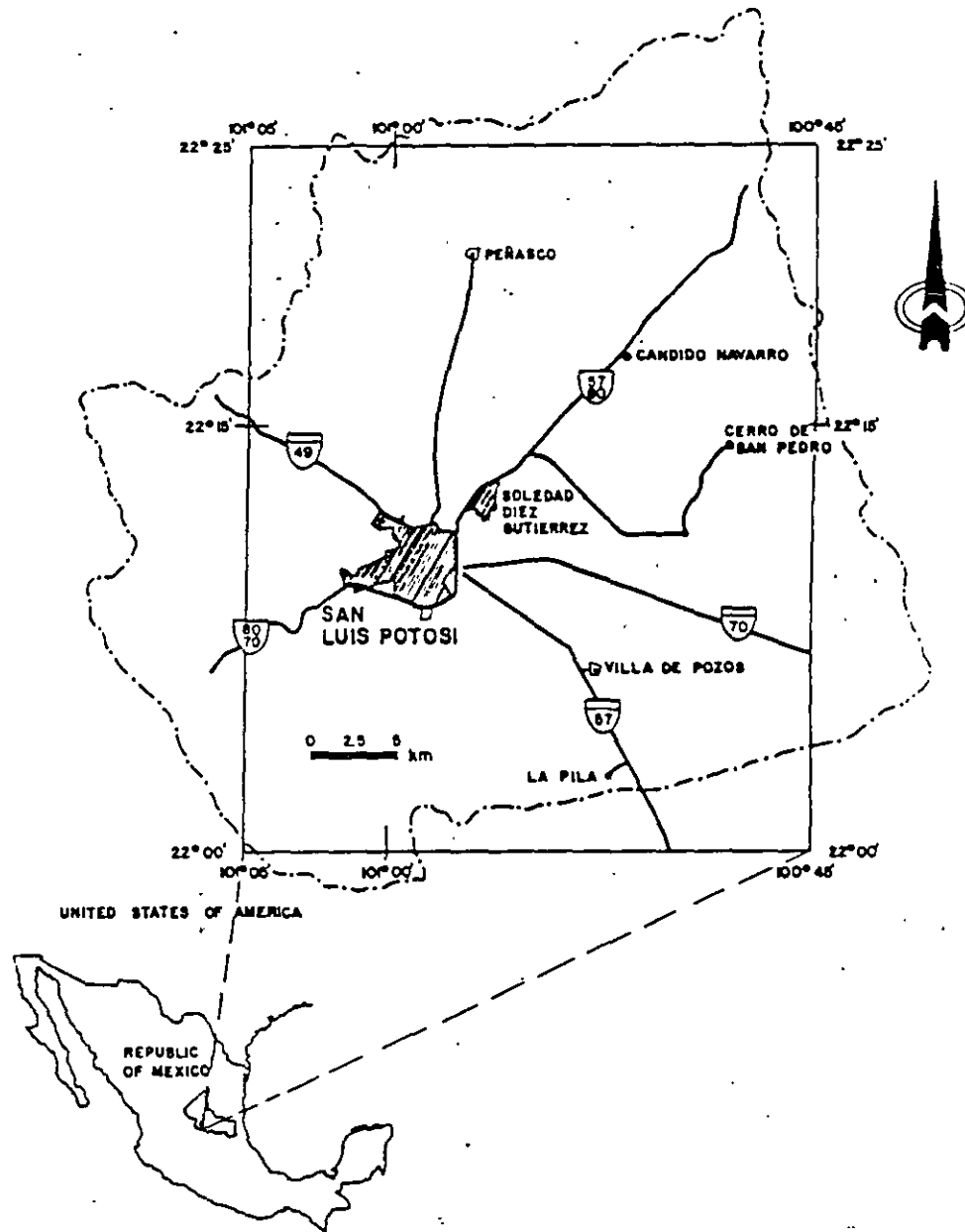

Figure 1: Location map of San Luis Potosí Basin

HYDROGEOLOGIC MODEL

On the basis of the available geological, geophysical, piezometric and hydrochemical information, the proposed hydrogeological model of the system includes a "shallow aquifer" of reduced yield and poor quality water. This aquifer overlies a "clay formation" which in turn confines a deeper aquifer. Most of the water is produced at this "deep aquifer", which has thermal activity (Fig.2). Below it, lay the "thermal sources".

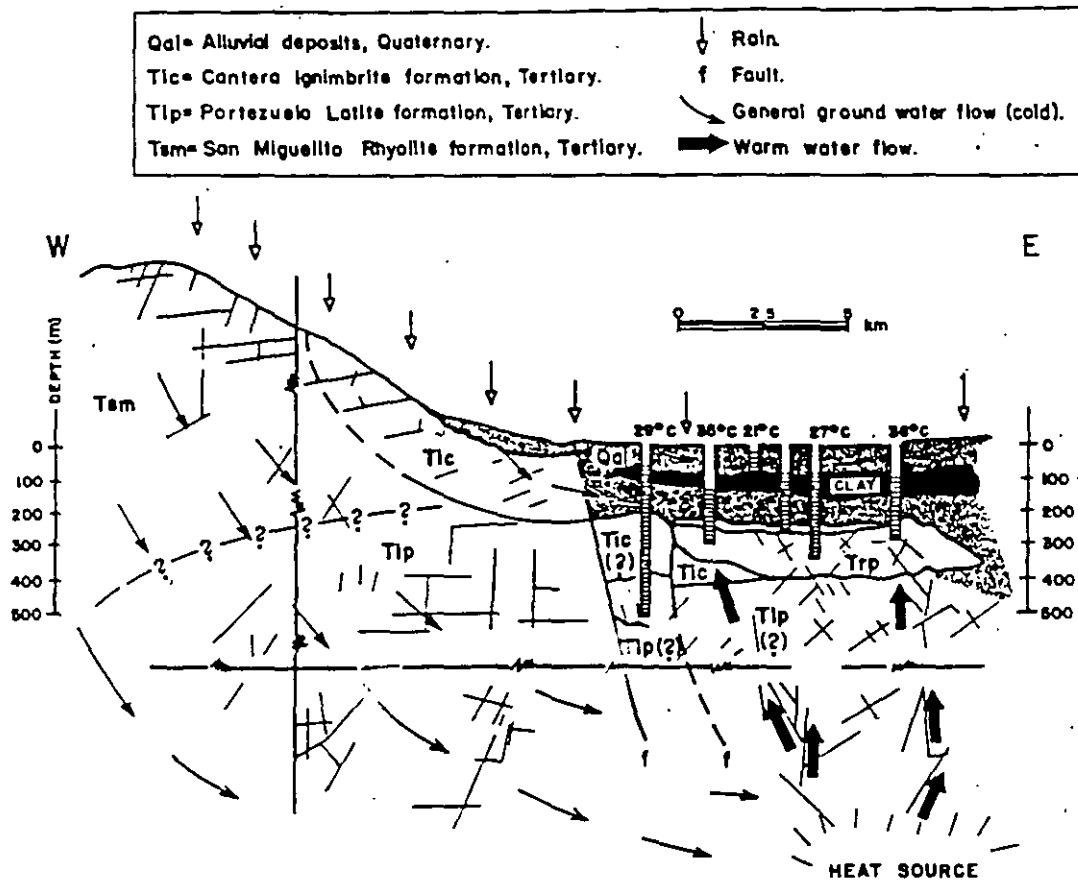

Figure 2: The hydrogeological model

In this figure, it can be observed, that the system of regional flow is important for aquifer performance, producing a vertical component of hot water. For a detailed geological description of the system, the reader is referred to the previous study: Instituto de Geofísica, UNAM (1988).

MODELLING OF THE SYSTEM

For the implementation of the numerical model, a conceptual model of its behavior was defined, suitable differential equations were adopted, a computer program was selected and its calibration was carried out using the available information. The piezometric levels produced by the program, were interpolated using the package SURFER: Golden Software, Inc., (1989) to obtain a more convenient graphical representation.

The conceptual model

The limits of the area included in the model, are shown in Fig. 3 and were based on geological considerations.

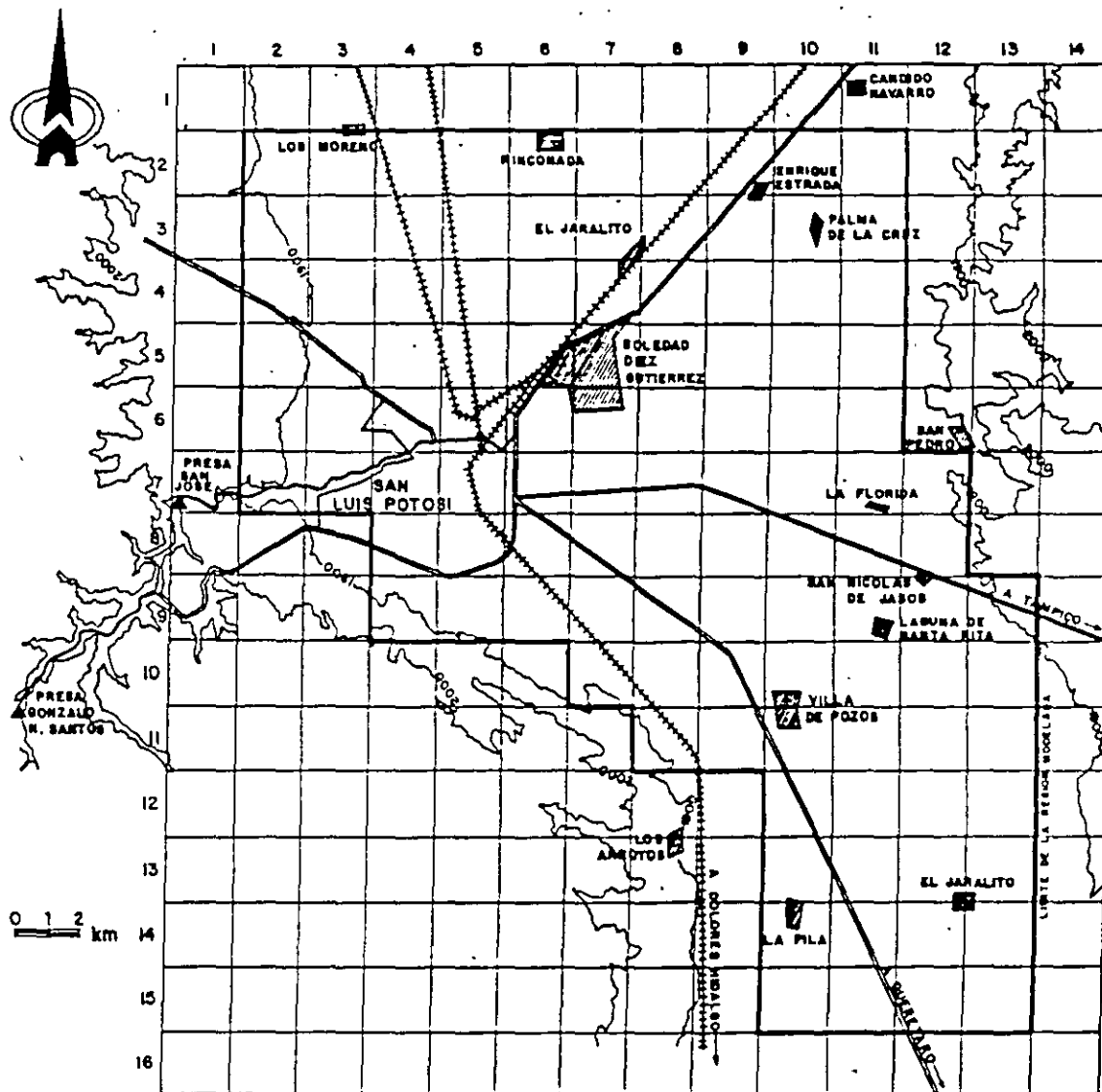



 Limit of the modeled region.

Figure 3: Grid used in the numerical simulation

The San Miguelito range at the west and the San Pedro range at the east, constitute natural boundaries because they present conditions of no flow, and at some places constant head (Fig. 4).

The
inf
the
loc
the
imp
aqu
exc

The
The

wher

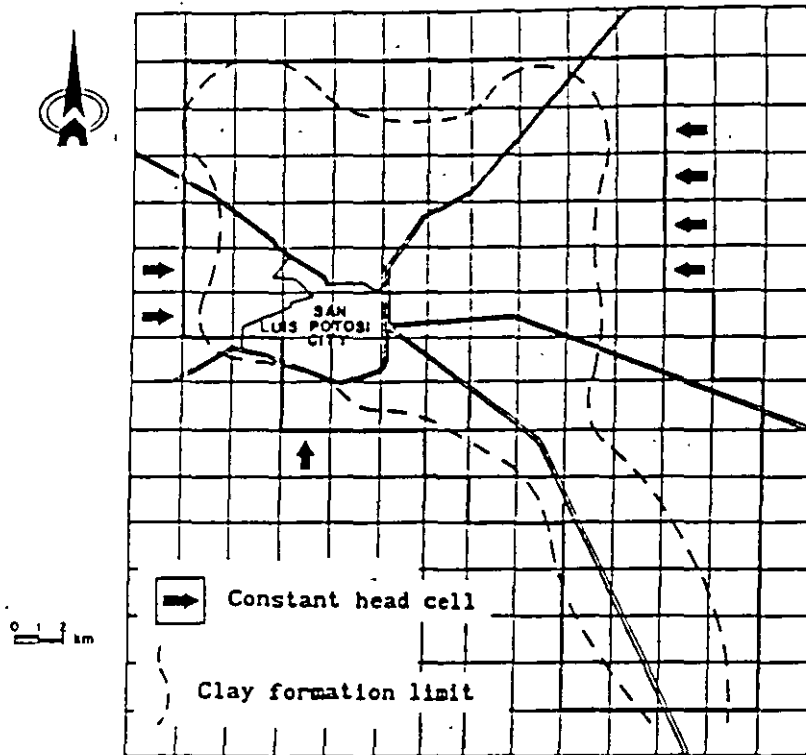

Figure 4: Area covered by the clay formation

The northern and southern limits were selected on the basis of the piezometric information that was available and they were taken as impermeable, because there is evidence that the flow there, is negligible. The shallow aquifer, located on the upper part of the system, functions as a unit independent of the deep aquifer, because the clay layer that separates them is sensibly impervious. Taking into account that most of the water is produced at the deep aquifer, the purpose of the model is the prediction of its behavior exclusively, leaving aside the shallow aquifer.

The Basic Equation

The governing equation used was:

$$\frac{\partial}{\partial x} \left(K_x \frac{\partial h}{\partial x} \right) + \frac{\partial}{\partial y} \left(K_y \frac{\partial h}{\partial y} \right) + \frac{\partial}{\partial z} \left(K_z \frac{\partial h}{\partial z} \right) = S_s \frac{\partial h}{\partial t} \quad (1)$$

where S_s = specific coefficient of storage $[L^{-1}]$
 K = Hydraulic conductivity $[LT^{-1}]$
 h = Hydraulic head $[L]$
 t = Time $[T]$

However, the analysis of the flow was mainly two-dimensional, because only two horizontal layers were incorporated in the model.

The computer code MODFLOW: McDonald & Harbaugh, (1984), was used in all calculations. This model applies the cells method which yields finite differences approximations.

The deep aquifer can be satisfactorily modelled using a 2x2 Km grid and applying finite difference schemes on them, as illustrated in Fig. 4. Layer I includes the best known part of the system, where the value of the hydraulic properties are known or at least can be estimated. Layer II was introduced to model the deeper, less known geological formations which supply the thermal water. The flow and interaction between layers I and II, is due to the differences of hydraulic head between them. In layer II, it was assumed a constant hydraulic head that remained greater than the head of layer I, throughout the runs. This induces a vertical component of flow whose magnitude can be adjusted varying the ratio of the hydraulic conductivity (K_z) to the thickness of the layer where the flow takes place.

An upper boundary condition of no flow was considered in layer I, which corresponds to the clay layer whose hydraulic conductivity is neglected. In the horizontal limits of the aquifer, either constant head or no flow boundary conditions were considered, as indicated in Fig. 4.

CALIBRATION

In the period January 1987- July 1989, heads were measured monthly in observation wells distributed throughout the region that was modelled. At the same time, the pumping rate was measured in some cases and estimated by indirect means in others.

In addition, the piezometric head distribution corresponding to 1960, is available and there are estimates of the historical evolution of the pumping rates.

The hydraulic properties of the known part of the aquifer were obtained by means of pumping tests and also some pumping tests available from previous studies were interpreted. Transmissivity varies between 1×10^{-5} and $8 \times 10^{-4} \text{ m}^2 \text{ s}^{-1}$. The calibration for layer I, started with these values and then were modified on the basis of the results of the calibration. The properties of layer II were adjusted until the behavior of the system was reproduced in a satisfactory manner.

In spite of the additional piezometric information that was available, the calibration was based on the period 1987 - 1989, which covers 30 months only. This was due to the better quality of the data for that period. Once the results of the calibration were obtained, the data of less quality that were available for the period 1960 - 1988, were used to verify it.

In the evaluation of the storage coefficients of the region modelled, 10 values that were determined by pumping tests were incorporated. The extension

of the confining clay layer was determined by means of the analysis of the prevailing geological conditions (inferred from well logs) and geophysical surveys. The values of the storage coefficients that were used for the cells that behave as confined, are between 2×10^{-4} and 7×10^{-3} . In the case of cells that perform as unconfined, values between 0.02 and 0.15, were used.

The initial runs, using the estimated values of S and T, led to the distribution of the piezometric heads shown in Fig. 5.

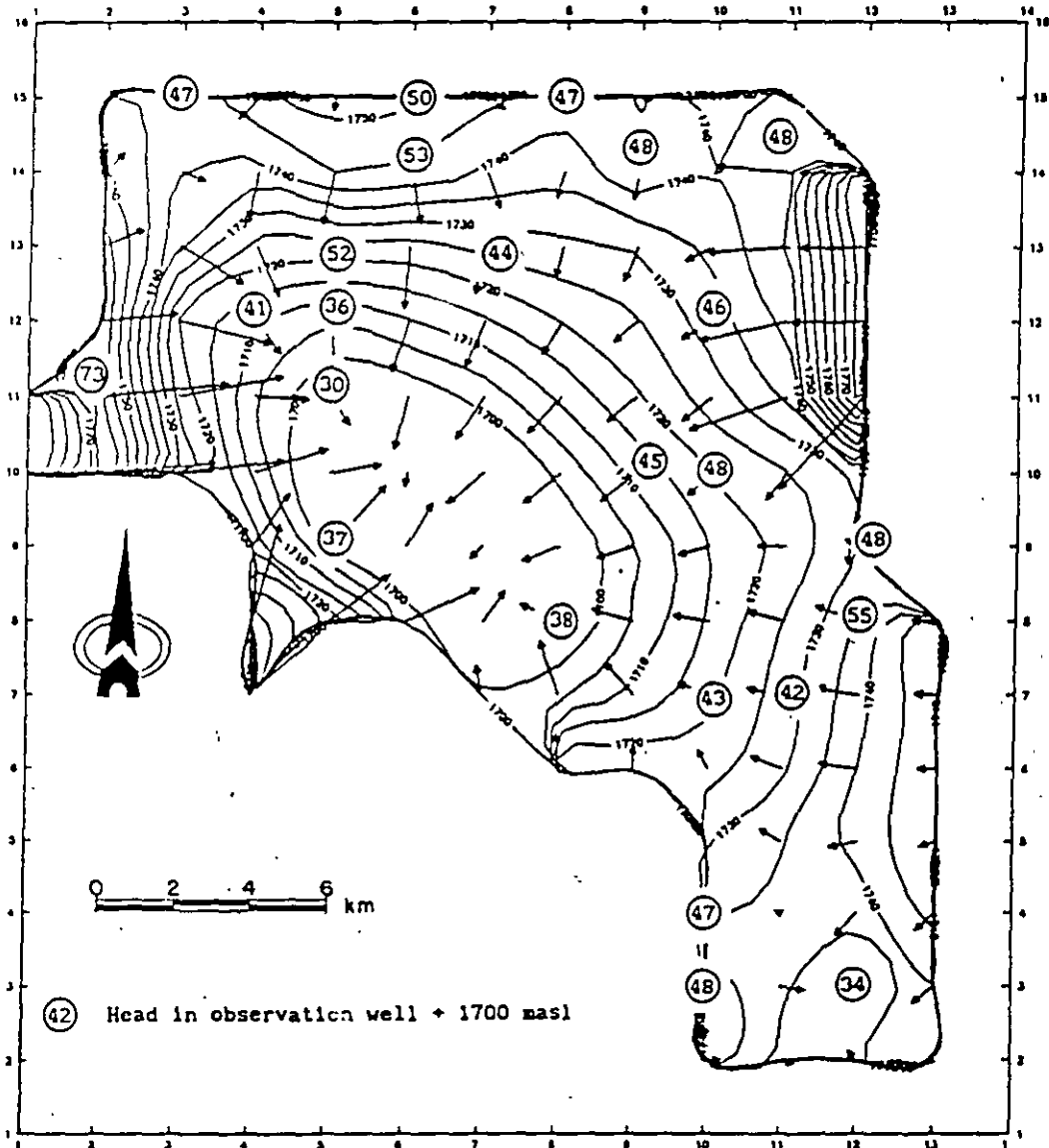

Figure 5: Contour map of predicted piezometric heads, without thermal sources

In this figure the predicted drawdowns deviate drastically from those observed, the greatest deviations occurring in the area where the thermal manifestations have been observed (Fig. 6).

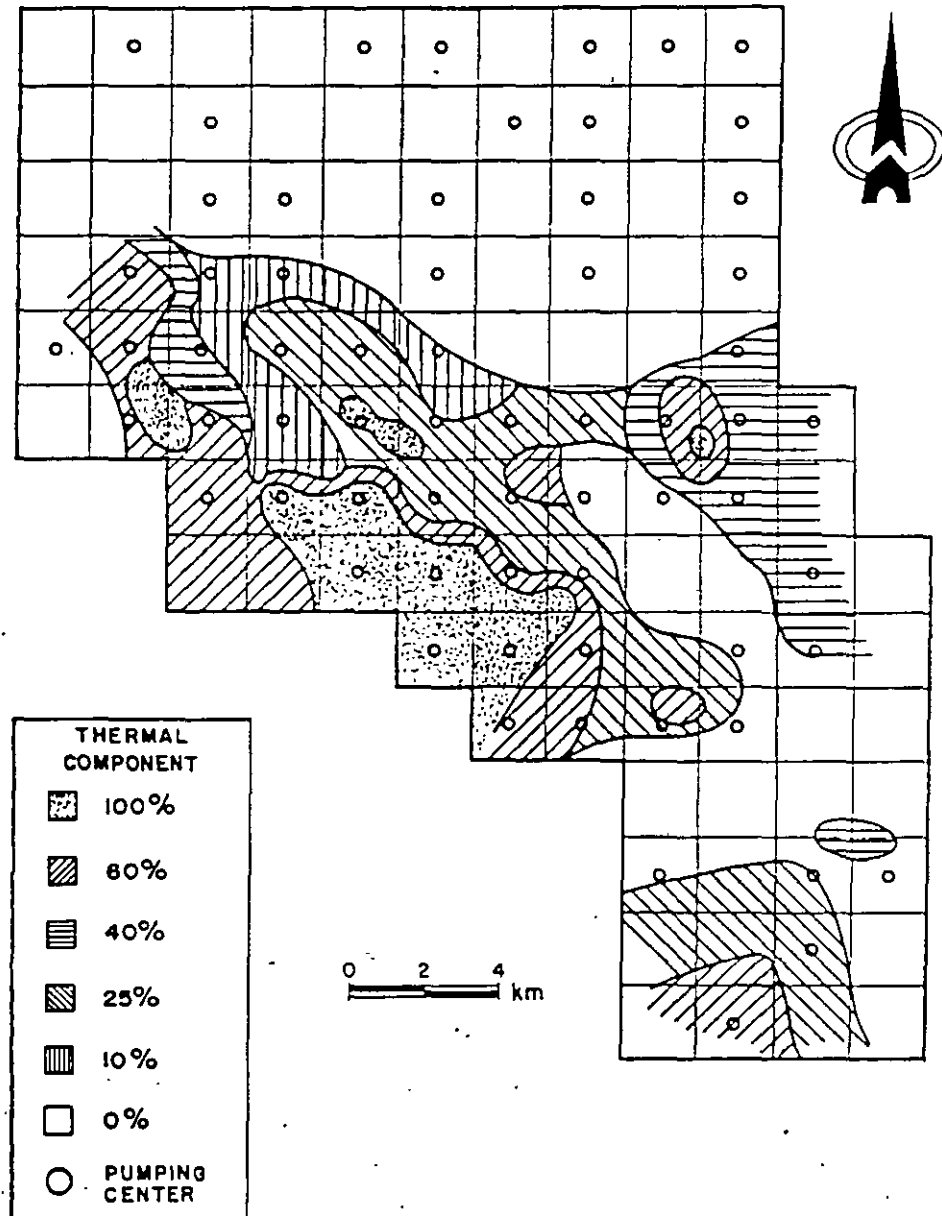

Figure 6: Location of thermal sources

The general conclusion drawn from these results, was that the observed behavior cannot be predicted satisfactorily using the observed values of S and T, when only horizontal flow is modelled. The yield of the actual system is much larger than the one obtained in such model.

The discrepancy between the observed and predicted heads, can be reduced in one of the following manners:

- a.- Increasing the storage coefficient of the aquifer, considering it as unconfined in all the region modelled.
- b.- Incorporating additional sources of water in the cells, where required.

The first option is unrealistic, since it contradicts geologic evidence directly supplied by well logs and must be discarded, in spite of the fact that it was used in a previous study: Niedzielsky, (1990).

On the other hand, the inclusion of additional sources in the model is fully justified by the hydrochemical and thermal evidences: Cardona (1990), Carrillo-Rivera (1992). They represent the vertical component of the regional system of flow that has been observed in the thermal area of the Valley of San Luis Potosi (Fig. 6). Therefore, this was the option that was adopted in the model. It was incorporated by means of an additional layer (layer II) whose properties were adjusted in the calibration of the model, assuming the piezometric head of that layer is constant.

Since the hydraulic properties of the main aquifer (layer I) are the best known, in the calibration, emphasis was placed in determining the properties of the thermal sources. A first guess of the values of the hydraulic conductivity in the vertical direction (K_z) between layers I and II, based on the temperatures and well discharges measured in the field, was used in the initial simulations, and then they were adjusted until the actual piezometric distributions in the thermal area were reproduced. The stopping criterion for the calibration process was that the actual heads should be predicted with an error of less than one meter in the thermal zone, as shown in Fig. 7.

Using the calibrated model, a global mass balance of the region was carried out. The results obtained are listed in Table 1.

Table 1: Mass Balance of the Aquifer

Concept	$Q(m^3 s^{-1})$	%
Aquifer storage	0.34	13
Lateral recharge (cold water)	0.36	14
Upward supply (hot water)	1.90	73
Total well extraction	2.60	100

The distribution of the supply, shows clearly that the most important contribution comes from the vertical flow which originates in the regional system and exhibits thermal anomalies.

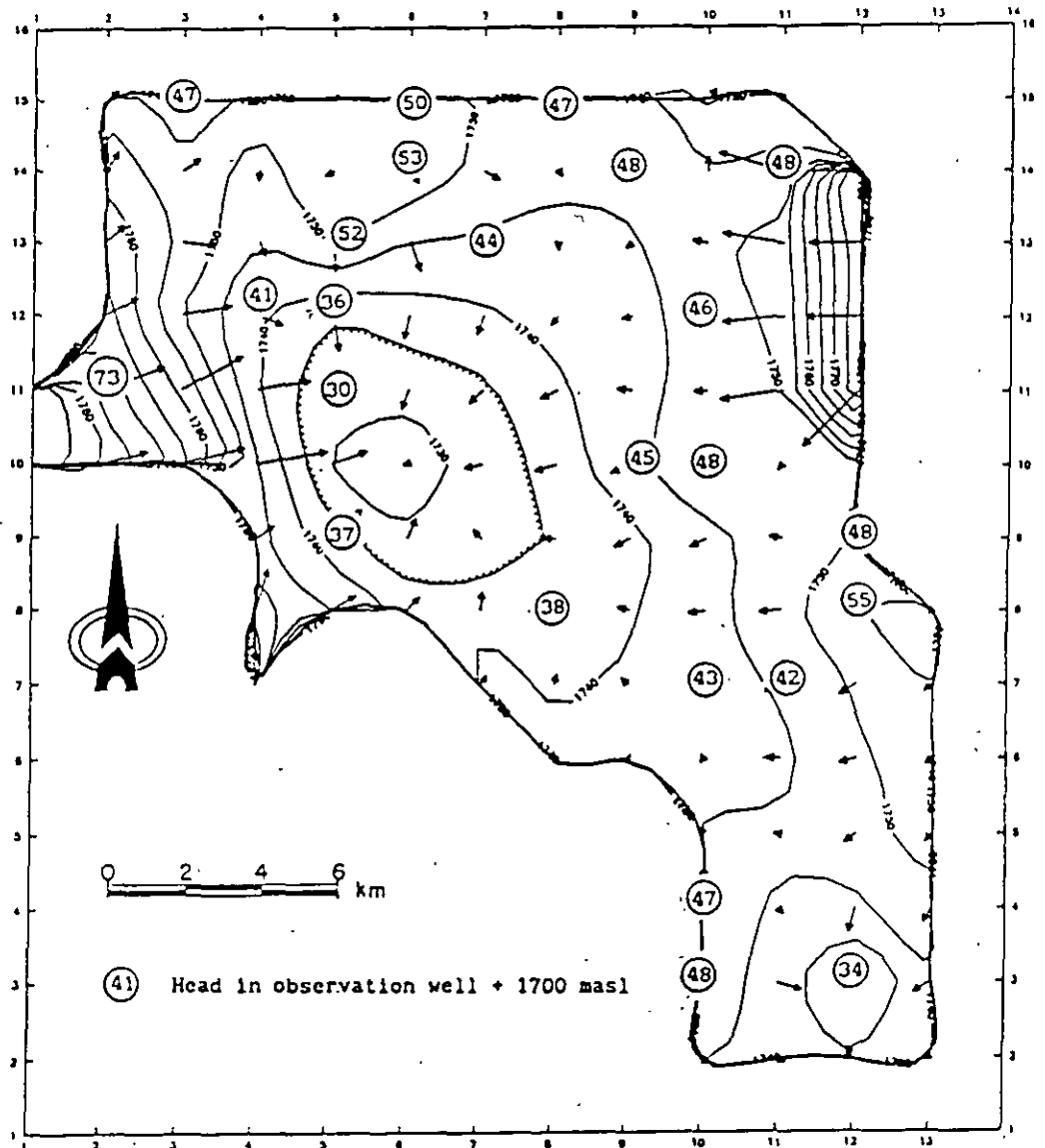

Figure 7: Contour map of predicted piezometric heads, after calibration

Long period verification

As was already mentioned, the information available for the period 1960 - 1988, was used to test the results of the calibration. Thus, after the calibration was completed, a run covering that period was carried out.

Taking the known initial conditions for 1960 and estimating the evolution of the rate of pumping in the period, the piezometric heads were predicted, using the calibrated model. The results of the simulation after 29 years, had differences of less than 3 meters between the observed and computed heads, in the thermal area. This indicates, specially taking into account the low quality of the information available for the period, that the parameters that were obtained in the calibration, are acceptable to make predictions of the behavior of the system, within a moderate range of accuracy.

TESTING DIFFERENT PUMPING POLICIES

The analysis of a wide range of exploitation policies of the system is necessary, to quantify the potential of the thermal sources, as a water supply for the city of San Luis Potosi.

Predictions of the behavior of the system for a period of 21 years (1989 - 2010), under different exploitation policies were carried out. The options considered were:

- I.0- Keeping the present extraction rate fixed during the whole period.
- I.1- Increasing the rate of extraction 5 % every 5 years.
- I.2- Increasing the rate of extraction 10 % every 5 years.
- I.3- Increasing the rate of extraction 20 % every 5 years.

- II.1- Increasing the rate of extraction in the thermal area exclusively (13 cells) 5% every 5 years.
- II.2- Increasing the rate of extraction in the thermal area exclusively (13 cells) 10% every 5 years.
- II.3- Increasing the rate of extraction in the thermal area exclusively (13 cells) 20% every 5 years.
- II.4- Increasing the rate of extraction in the thermal area exclusively (13 cells) 40% every 5 years.

In Table 2 the results obtained for the different policies that were tested are shown. For each policy the total volume extracted during the period of 21 years is given and then the percentages which originate in the thermal sources, the storage of the aquifer and the neighboring regions is indicated. Finally, in the last column the total volume of drawdown produced during the whole period in the modelled region, is given in millions of cubic meters. These results are also illustrated in graphical form, in Fig. 8. Clearly, to ensure a drawdown as low as possible, locating the additional demand in the thermal region is the best option.

Table 2: Predictions for the period 1989 - 2010 under different policies

Policy	Total Pumped Volume ($m^3 \times 10^6$)	Of Thermal Origin (%)	From Aquifer Storage (%)	From the Boundary (%)	Drawdown Volume ($m^3 \times 10^6$)
I.0	1698	81	3	16	3440
When increments in pumping are uniformly distributed					
I.1	1915	81	5	14	6000
I.2	2153	76	7	17	8800
I.3	2702	77	11	12	16000
When all increments of pumping are taken from thermal area					
II.1	1866	83	4	13	4800
II.2	2069	81	5	14	6400
II.3	2184	82	6	12	7600
II.4	2946	82	8	10	13600

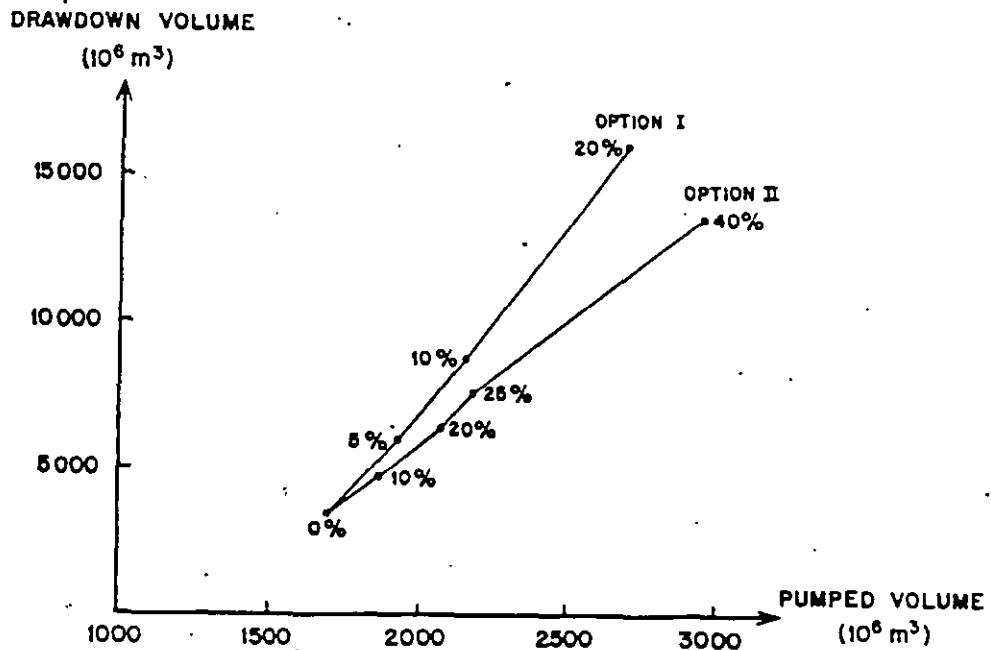

Figure 8: Comparison of simulated policies

CONCLUSIONS

A numerical model that takes into account the contribution of thermal sources was developed, and using it, different operation policies have been tested, for the aquifer of the City of San Luis Potosi.

Initially, it was intended to implement a model without thermal sources. However, it turned out to be impossible to achieve a model capable of predicting the observed behavior, when only horizontal flow was modelled. This pointed out the need of incorporating thermal sources in the model, in order to explain the vertical flux coming from deeper geological formations, whose hydraulic properties are unknown. This vertical supply was incorporated in the model, introducing a layer of constant hydraulic head in the lower aquifer.

Since the properties of such layer were unknown, it was necessary to derive them during the calibration process. The main parameter that was adjusted was the vertical hydraulic conductivity that exists between layers I and II. At the same time, the hydraulic properties, T and S, of the aquifer and the boundary conditions were also adjusted. The fact that an additional parameter was introduced in the calibration, made this process more complicated than is usual for this kind of applications. However, this form of proceeding is similar to what is usually done when applying modelling techniques in the horizontal plane, for which it is standard to eliminate neighboring regions with insufficient hydrological information by imposing suitable boundary conditions. In many cases, the supply coming from such regions is quite significant for the behavior of the part of the aquifer which is modelled.

The results of the calibration were satisfactorily verified by reproducing the observed behavior in a longer period (1960-1988) of exploitation of the aquifer, for which incomplete hydrometric information was available. The results of this study indicate that the procedure used here, to study a deep geological formation for which no information is available, may be useful more generally. In particular, in the case study here reported, in spite of the insufficient knowledge of the deep formation, it was possible to make recommendations for the policies to be followed in the production of the aquifer. These recommendations are better founded than if the lack of information about the thermal sources, had inhibited the development of such model.

The distribution of piezometric heads predicted on the assumption that the present rate of pumping is continued through the whole period, 1989 - 2010 (Fig. 9 option I.0) indicates that the present extraction can be continued without producing exceedingly large drawdowns.

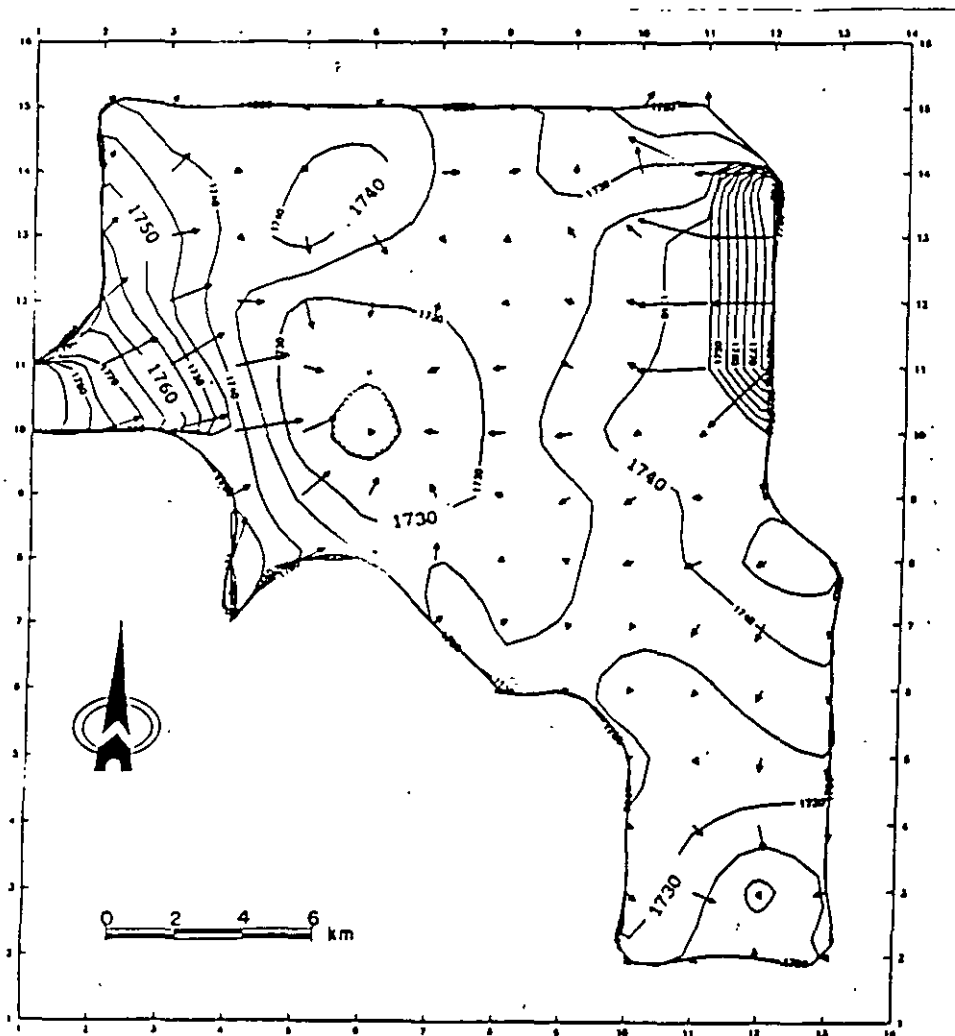

Figure 9: Contour map of predicted piezometric heads (1989 pumping rate)

Figure 8, clearly illustrates the fact that if the pumping rate is to be increased, the most convenient option from the point of view of keeping the drawdowns as small as possible, is to concentrate the demand in the thermal area. However, if such policy is adopted, the supply would contain a greater volume of thermal water, which would deteriorate its quality. Thus, in such case, it would be important to monitor the dissolved ions and the water temperature. If this is done, it should be recommended that the information gathered in this manner, be used to improve the numerical model and to test the assumptions on which it is based.

REFERENCES

- Cardona A., 1990. *Caracterización Físico-Química y origen de los sólidos disueltos en el agua subterránea en el Valle de San Luis Potosí: su relación con el Sistema de Flujo*. M.S. Thesis, Universidad Nacional Autónoma de Nuevo León, México.
- Carrillo-Rivera J.J., 1992. *The hydrogeology of the San Luis Potosí area*. Ph. D. thesis, London University, U.K.
- Golden Software, Inc., 1989. *Surfer reference manual*. P.O. Box 281, Golden, Colorado 80402 U.S.A.
- Instituto de Geofísica UNAM, 1988. *Estudio geofísico-geohidrológico del Valle de San Luis Potosí: Contrato cc-86-3140, Informe Interno* Secretaría de Agricultura y Recursos Hidráulicos, México, D.F.
- McDonald M. & Harbaugh A., 1984. *A Modular three-dimensional finite-difference ground-water flow model*. U.S. Department of the Interior U.S. Geological Survey, National Center, Reston, Virginia.
- Niedzielski H, 1990. *Perspectivas del suministro de agua a la Ciudad de San Potosí*. Ciencia, *Revista de la Academia de la Investigación Científica*. vol 41, No. 5 México, D.F. 153-162 pp.



**FACULTAD DE INGENIERIA U.N.A.M.
DIVISION DE EDUCACION CONTINUA**

CURSOS ABIERTOS

**“ IX CURSO INTERNACIONAL DE
CONTAMINACIÓN DE ACUÍFEROS “**

MODULO III

MODELOS MATEMÁTICOS EN GEOHIDROLOGÍA

TEMA

**MANUAL PARA LA UTILIZACIÓN
DEL VISUAL MODFLOW**

**EXPOSITOR: ING. LUIS ERNESTO LESSER CARRILLO
1997**

MANUAL PARA LA UTILIZACION DEL VISUAL MODFLOW

**FACULTAD DE INGENIERIA U.N.A.M.
DIVISION DE EDUCACION CONTINUA**

**IX CURSO INTERNACIONAL DE
CONTAMINACION DE ACUIFEROS**

**MODULO III
MODELOS MATEMATICOS EN GEOHIDROLOGIA Y
CONTAMINACION DE ACUIFEROS**

**POR:
ING. LUIS ERNESTO LESSER CARRILLO**

1. ABRIR UN ARCHIVO O CREAR UNO NUEVO

1. En *file* se utiliza *open* para abrir un modelo ya existente.
2. En *file* se utiliza *new* para crear un modelo nuevo.
3. Al crear un modelo nuevo se pide el nombre y el subdirectorío donde se va a almacenar.
Es recomendable tener un subdirectorío específico para cada modelo.
4. A continuación se piden las unidades en que se trabajara a lo largo del modelo.
5. En este momento se pregunta si se desea tener como base algún dibujo (generalmente hecho en autocad). El archivo tiene que estar en formato *dxg*, en autocad se tecléa *dxgout* para crear un archivo en este formato.
6. A continuación se dan las características de la malla de discretización. Se piden la coordenada mínima y máxima en *X*, así como el número de columnas deseadas en el modelo. De esta manera el modelo calcula el tamaño de cada columna.
7. Los mismos datos se requieren para el eje *Y* (renglones) y el eje *Z* (capas). Esta malla podrá después ser modificada. Nótese que si se toma como base un dibujo *dxg*, las coordenadas máximas y mínimas son tomadas de este dibujo, aunque si se desea se pueden modificar.
8. A continuación se muestra la zona discretizada y el plano base. En el menú principal se escoge *input* para alimentar el modelo con los datos.

2. ALIMENTACION DE LOS DATOS DEL MODELO

- En el menú que aparece del lado izquierdo existen 3 opciones para visualizar las columnas, renglones o capas del modelo.
- En *goto previous* o *next* se puede visualizar la capa anterior o, la siguiente. También se puede visualizar la columna o renglón siguiente o anterior, si estas se están visualizando.
- Del menu que se encuentra en la porción baja de la pantalla:

F1 - (*help*) Ayuda.

F2 - Después de presionarlo podemos obtener las coordenadas de cualquier punto del modelo.

F3 - (*save*) Para salvar.

F4 - (*map*) Para introducir otro dibujo o plano base al modelo. Se pueden añadir el número de dibujos o planos base que se deseé.

F5 - (*zoom in*) Para tener un acercamiento de alguna porción del modelo.

F6 - (*zoom out*) Para tener una visualización completa de la zona del modelo.

F7 - (*pan*) Para desplazarse por el modelo al estar en acercamiento.

F8 - (*vert exag*) Para determinar la exageración vertical que se utilizará para poder visualizar mejor las secciones.

F9 - (*overlay*) Esta opción se utiliza para “apagar” o “prender” las capas de dibujos. Es decir para poder visualizar o no ciertos dibujos que se hayan importado en *F4*, o la distribución de las diferentes características del modelo como los pozos, recargá, conductividad hidráulica, etc.

F10 - (*main menu*) Para regresar al menú principal.

1. Modificación de la malla y delimitación de celdas activas e inactivas

- En el menú superior se selecciona *grid*.
- Con las opciones *add column*, *delete column* y *add row*, *delete row* se pueden agregar o borrar columnas o renglones del modelo.

- Lo mismo se puede hacer con las capas cuando se visualiza una sección. Nótese que ésta es una discretización matemática, y no forzosamente se necesita discretizar en el mismo número de estratos geológicos. Es decir, un estrato geológico puede subdividirse para efectos de discretización, teniendo las mismas características todas las subcapas creadas para éste estrato.
- Para importar la superficie del terreno o la base de alguna capa, se utiliza la opción *import surface*. Con esto en vez de que el modelo sea un cubo perfecto, se podran tener en cuenta las irregularidades del terreno, o de las capas geologicas.
- Las superficies se pueden importar en archivos en formato *ASCII*. Los archivos deben ser una lista de tres columnas de las coordenadas en X,Y,Z de varios puntos, o se puede importar un archivo creado en SURFER (*grd*).
- Las celdas inactivas son zonas donde el modelo no interviene. Para delimitarlas se utiliza la opción *inactive cells*. Se puede trazar un polígono para marcarlo como inactivo. Para revertir la elección se puede tambien marcar, un polígono activo.
- Esta delimitación se realiza en una sola capa. Es importante copiar esta información a las capas que lo requieran, usando el comando *copy polygon*.

2. Asignación de valores de conductividad hidráulica y almacenamiento

- En el menú superior se selecciona *properties* y ya sea *conductivity* o *storage*.
- A continuación se asignan los valores de conductividad hidráulica, almacenamiento y porosidad que por default asignara el modelo a todos los nodos.
- Posteriormente se zonifica la malla con las opciones del menú izquierdo *assign single*, *polygon* o *window*.
- Después de seleccionar una zona se puede elegir entre darle un valor nuevo (*new*) o de asignarle algún valor que haye sido designado con anterioridad.
- Dependiendo si se escoje *conductivity* o *storage* en la opción de *properties*, se podrá zonificar la conductividad hidráulica o el almacenamiento y la porosidad.

- Es importante copiar las propiedades necesarias a las capas que lo requieran utilizando la opción *copy layer* del menu izquierdo.
- **Nota:** A cada nueva propiedad se le asigna un color distinto para ser distinguido en el modelo. El color blanco representa el valor que se dió como defalut.

3. Asignación de fronteras

- En *boundaries* se encuentran las diferentes opciones de frontera. Se pueden asignar como línea, polígono o ventana por medio del menú de la izquierda.
- En la opción de *recharge* se agrega la regarga en mm/año. Nótese que no solo la recarga por lluvia puede ser representada de esta manera, tan solo se necesitan respetar las unidades en que esta recarga se asigna.

4. Alimentacion de la información de los pozos

- En la opción de pozos (*wells*) se pueden añadir, borrar, copiar o editar pozos por medio del menú izquierdo.
- Al seleccionar *add well* se localiza el punto donde se localiza el pozo. En la ventana que aparece a continuación se agregan los datos del pozo como el nombre, el intervalo en que el pozo se encuentra ranurado y el historial de bombeo del pozo.

NOTAS:

- a) No se puede nombrar un pozo como otro anterior.
- b) Las unidades de bombeo son $m^3/día$.
- c) Si el pozo es de recarga las unidades de bombeo se denotan con signo positivo.
- d) Si el pozo es de bombeo las unidades de bombeo se denotan con signo negativo.
- e) El modelo no tiene una escala de tiempo real, así que es necesario tomar la fecha en que se inicia la simulación como día cero dentro del modelo. De esta manera las fechas del historial del pozo, así como el resto de los datos del modelo que tienen variación con el tiempo, deben de ser asignados en número de días a partir de la fecha que se tomó como día cero.

3. PARA CORRER EL MODELO

- En el menú principal se escoge *run*.
 - Se escoge si la simulación es en estado transitorio (*transient*) o estacionario (*steady-state*).
 - Se selecciona *run*, y se selecciona *modflow*.
 - Si se desea correr el *modptah*, zona de balance (*zone budget*) o *MT3D* también se seleccionan.
-

4. PARA VISUALIZAR LOS RESULTADOS

- En el menú principal se selecciona *output*.
- Si el modelo fue corrido en estado transitorio, en *time* se puede escoger el momento en el tiempo en que se desea visualizar la configuración de la superficie piezométrica.
- En *goto* se puede visualizar la configuración de la superficie piezométrica en las diferentes capas.
- En *options* se puede modificar el intervalo utilizado para configurar y el valor del contorno máximo y mínimo.
- En el menú superior, en *velocities* se obtienen vectores del flujo del agua en donde se aprecia la dirección del movimiento del agua subterránea. En *options* se puede escoger el tamaño relativo de estos vectores y su densidad por área. **Estos vectores no son propiamente líneas de flujo, ya que estas, por definición no se cruzan entre si.**

EJEMPLO DEL VISUAL MODFLOW

**FACULTAD DE INGENIERIA U.N.A.M.
DIVISION DE EDUCACION CONTINUA**

**IX CURSO INTERNACIONAL DE
CONTAMINACION DE ACUIFEROS**

**MODULO III
MODELOS MATEMATICOS EN GEOHIDROLOGIA Y
CONTAMINACION DE ACUIFEROS**

**POR:
ING. LUIS ERNESTO LESSER CARRILLO**

1. DESCRIPCION DEL PROBLEMA

Este ejemplo está basado en el flujo del agua subterránea en un sistema formado por un acuífero libre en la porción superior, un acuitardo en la porción media, y un acuífero confinado en la porción inferior, como se muestra en la figura 1.





Figura 1. Dimensiones del acuífero

Notas:

- Este ejemplo está tomado del manual de Visual Modflow por Waterloo Hydrogeologic Inc.
- El símbolo  significa enter.
- El símbolo  significa presionar el botón izquierdo del mouse.

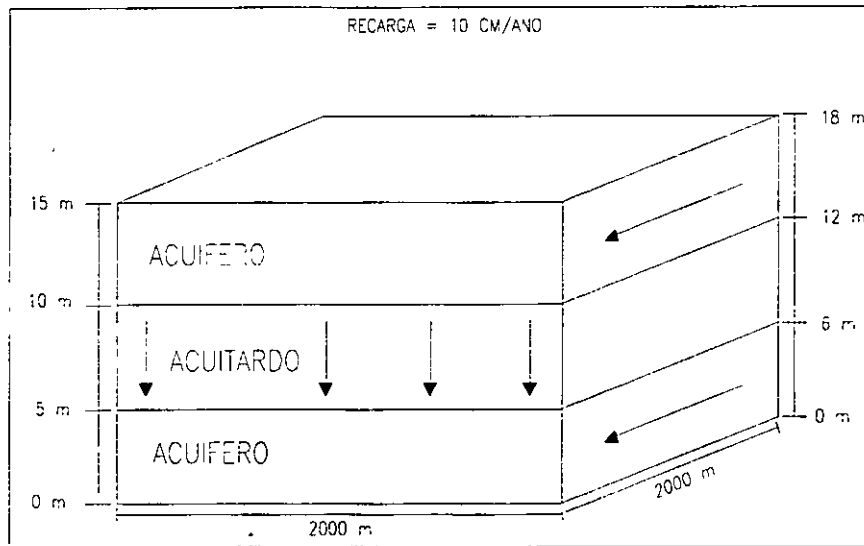
2. CREACION DE UN NUEVO MODELO

Estando en el sistema operativo teclear

VMODFLOW ↵

Esto nos lleva a la pantalla de Visual Modflow

↵ O.K.

↵ FILE

↵ NEW

Aparecerá una ventana preguntando por el nombre del nuevo modelo.

Teclear el nombre del nuevo modelo:

VMEJEM ↵

(Visual Modflow asigna automáticamente la terminación .vmf)

Aparecerá una ventana para escoger las unidades deseadas (figura 2). Las unidades se seleccionan utilizando el mouse.



Figura 2. Ventana de selección de unidades

- meters
- m/sec
- days
- m³/day
- mm/year

- O.K.

3. DISEÑO DE LA MALLA

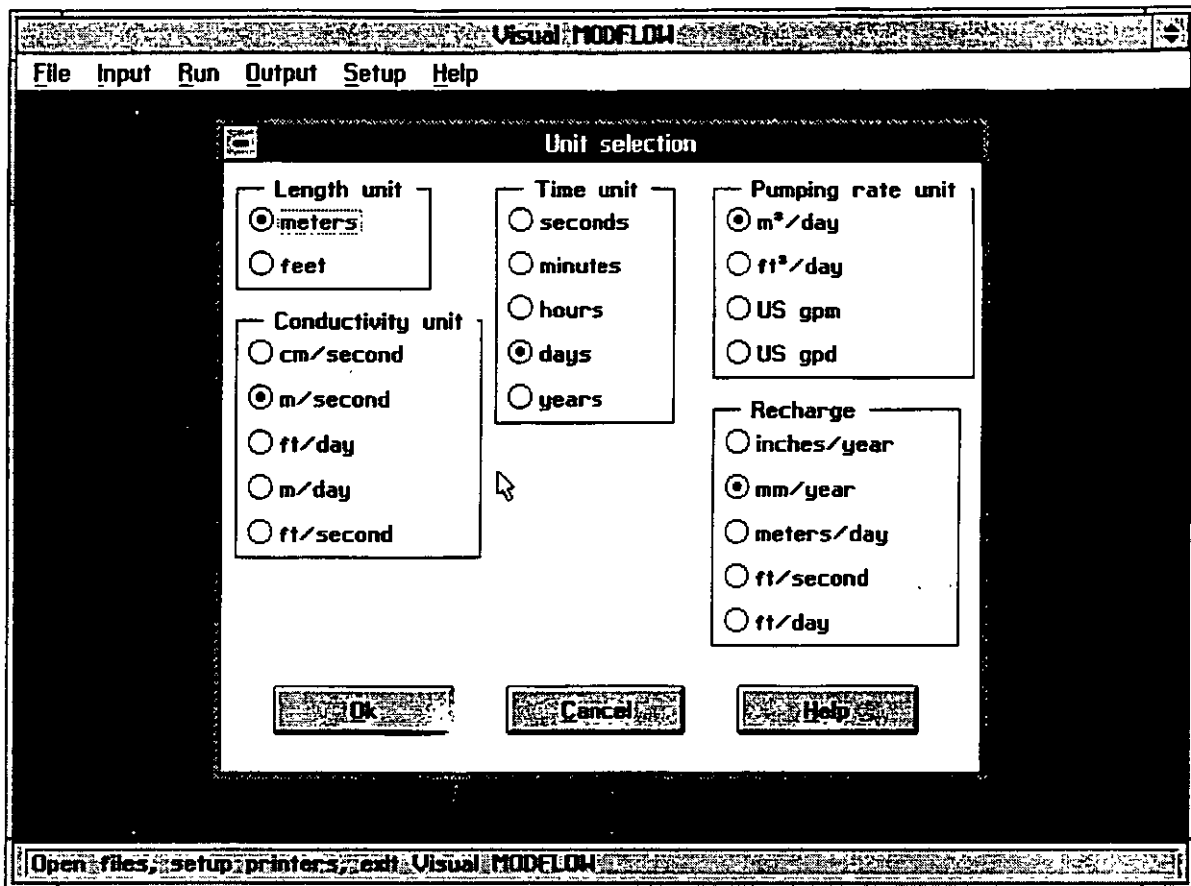
La siguiente ventana preguntará si se desean importar las coordenadas de un mapa en formato *dxf*.

YES

VMEXAMP.DXF

En el caso en que se ha escogido un mapa, Visual Modflow leerá las coordenadas máximas y mínimas del mapa y las sugerirá como las dimensiones del modelo. Aparecerá una ventana para definir las dimensiones y características de la malla (figura 3) solo se requiere teclear sobre los espacios o sobre los valores sugeridos para modificarlos.



Figura 3. Ventana de diseño de la malla

EJEMPLO DEL VISUAL MODFLOW

Enter number of columns 40 ↵
Enter Minimum X (m) 0 ↵
Enter Maximum X (m) 2000 ↵

Enter number of rows 40 ↵
Enter Minimum Y (m) 0 ↵
Enter Maximum Y (m) 2000 ↵

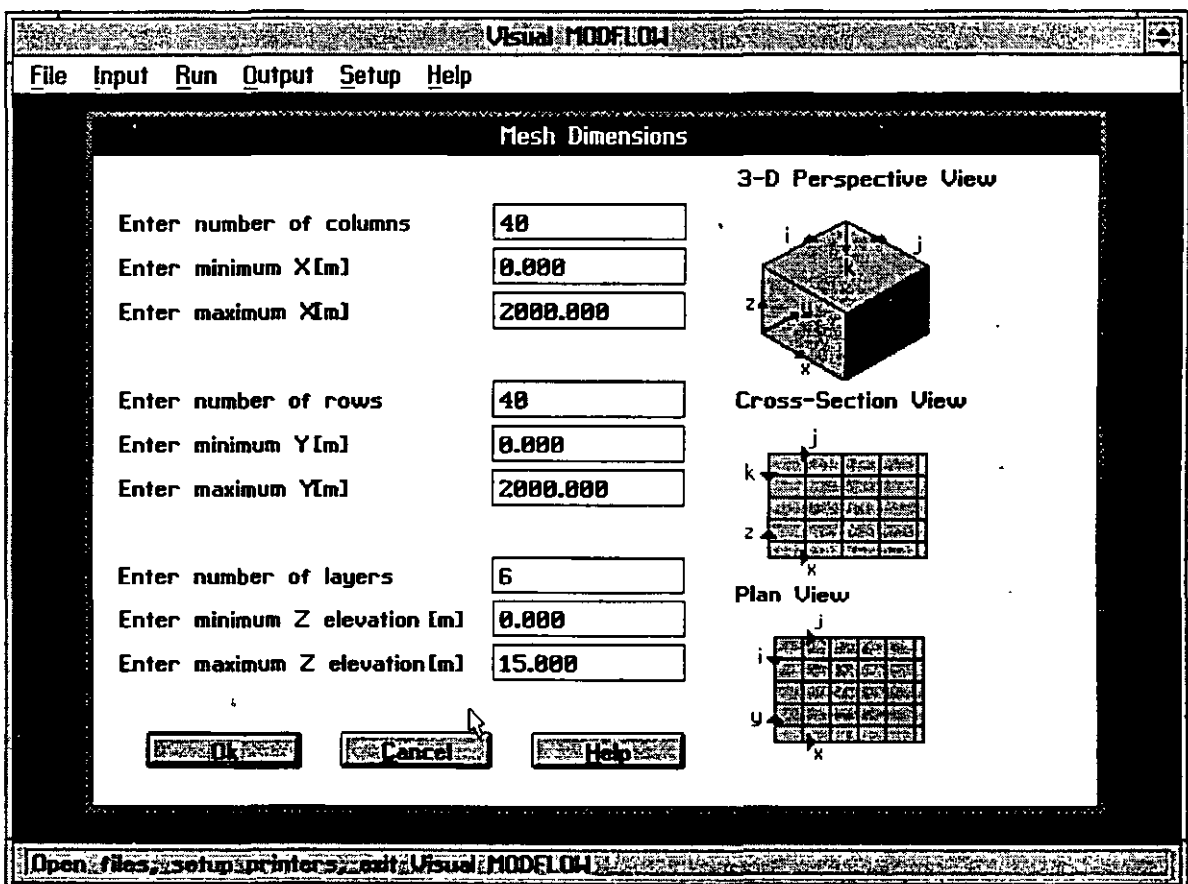
Enter number of layers 6 ↵
Enter Minimum Z (m) 0 ↵
Enter Maximum Z (m) 15 ↵
↵ O.K.

Una malla de 40 x 40 y el plano base aparecerán en la pantalla (figura 4).



Figura 4. Archivo importado en formato *dxg*

4. REFINAMIENTO DE LA MALLA

Se necesita refinar la malla alrededor de los pozos de abastecimiento de agua (*supply wells*) y de la perforación abandonada (*abandoned borehole*). El tamaño de la celda representa el tamaño del pozo, por lo tanto una malla mas discretizada simulará el pozo de una manera mas realística. Además del tamaño del pozo, si existe abatimiento alrededor del pozo, una discretización mayor producirá pendientes menos abruptas del nivel estático en zonas de abatimiento.

☞ en INPUT

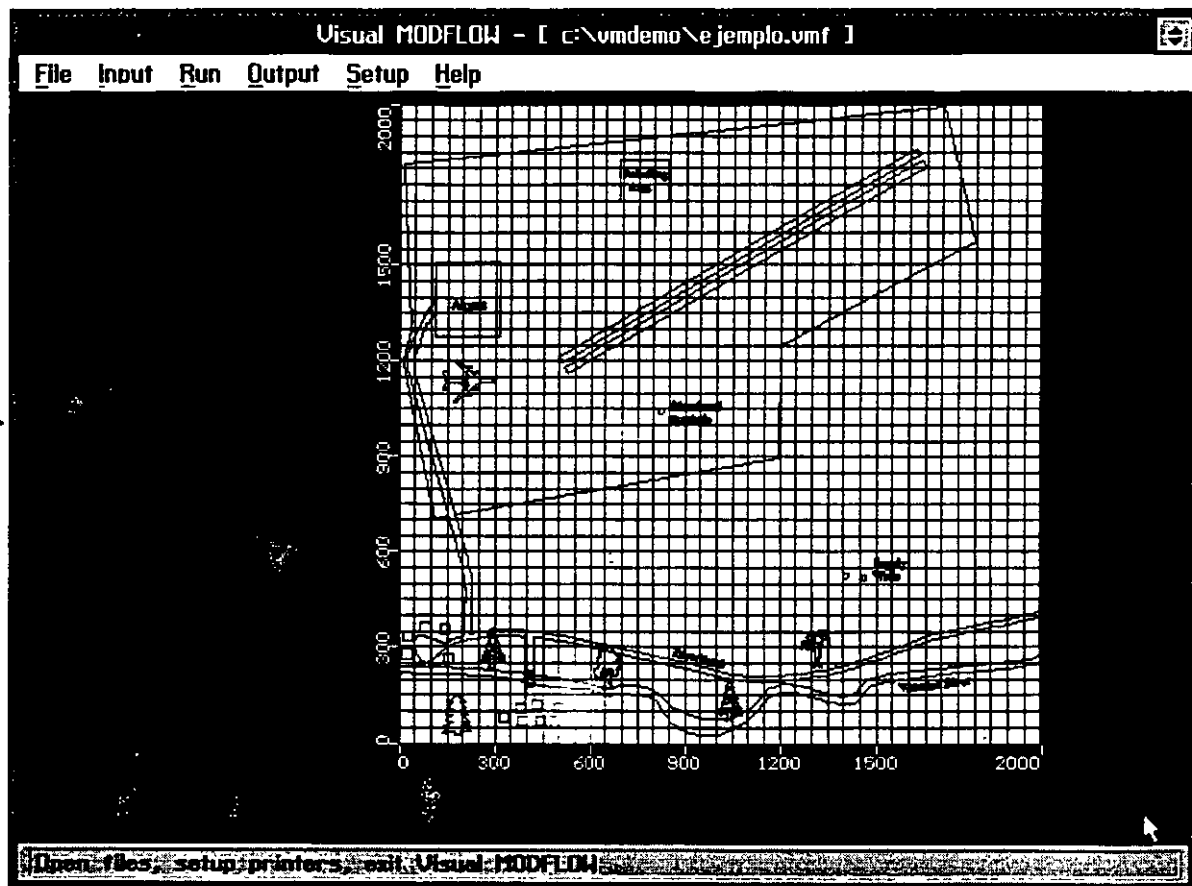
☞ en ADD COLUMN

Mover el mouse a cualquier lugar en la malla y ☞ el BOTON DERECHO DEL MOUSE. Haciendo esto se puede definir los lugares exactos para definir la discretización de la malla. Aparecerá una ventana para la información de la malla (figura 5).



Figura 5. Ventana de refinamiento de la malla

Escoger **EVENLY SPACED GRID LINES FROM:** (líneas igualmente espaciadas desde:) en el círculo vacío.

En las ventanas asignar los siguientes valores:

from 1350 ↵

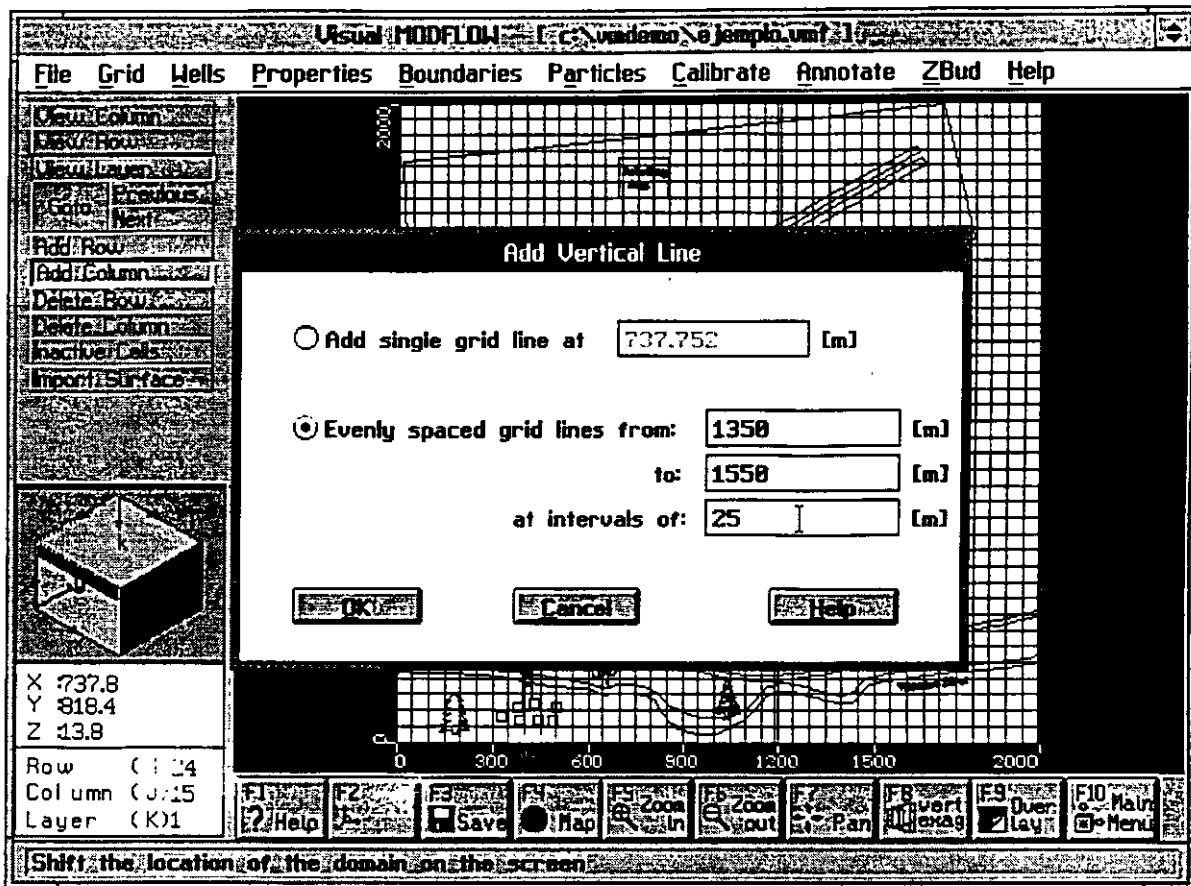
to 1550 ↵

at intervals of 25 ↵

en O.K.

en ADD ROW

Mover el mouse a cualquier lugar en la malla y el BOTON DERECHO DEL MOUSE.

Aparecerá una ventana para la información de la malla.

Escoger **EVENLY SPACED GRID LINES FROM:** (líneas igualmente espaciadas desde:) en el círculo vacío.

En las ventanas asignar los siguientes valores:

from **450**

to **600**

at intervals of **25**

en O.K.

Esto a refinado la malla alrededor de los pozos de abastecimiento de agua (*supply wells*).

Ahora lo haremos alrededor de la perforación abandonada (*abandoned borehole*).

en ADD COLUMN

Mover el mouse a cualquier lugar en la malla y el BOTON DERECHO DEL MOUSE.

Aparecerá una ventana para la información de la malla.

Escoger **EVENLY SPACED GRID LINES FROM:** (líneas igualmente espaciadas desde:) en el círculo vacío.

En las ventanas asignar los siguientes valores:

from **795**

to **900**

at intervals of **10**

en O.K.

en ADD ROW

Mover el mouse a cualquier lugar en la malla y el BOTON DERECHO DEL MOUSE.

Aparecerá una ventana para la información de la malla.

Escoger **EVENLY SPACED GRID LINES FROM:** (líneas igualmente espaciadas desde:) en el círculo vacío.

En las ventanas asignar los siguientes valores:

from **950**

to **1100**

at intervals of **10**

en O.K.

Ahora vamos a determinar la exageración vertical.

☞ VIEW ROW

Mover el cursor a cualquier lugar en la malla. Al mover el cursor de arriba hacia abajo de la malla el renglón ocupado cambia a color rojo. ☞ en cualquier renglón. Ahora ha sido transferido de una vista aérea a una vista de sección. En este momento el modelo no tiene exageración vertical. Para poder visualizar la sección mejor:

☞ F8 (Del menú de la parte inferior de la pantalla)

Aparece una ventana, escribir:

25 ↵

☞ O.K.

Ahora se visualizan las 6 capas en la pantalla.

5. PARA IMPORTAR UNA SUPERFICIE

☞ VIEW COLUMN

Mover el mouse a la malla y ☞ en cualquier columna.

☞ IMPORT SURFACE

Aparecerá una ventana como la de la figura 6.



Figura 6. Menú para importar superficies

☞ en CHOOSE FILENAME

Para escoger el archivo conteniendo la superficie.

☞☞ VMEXAMP.ASC

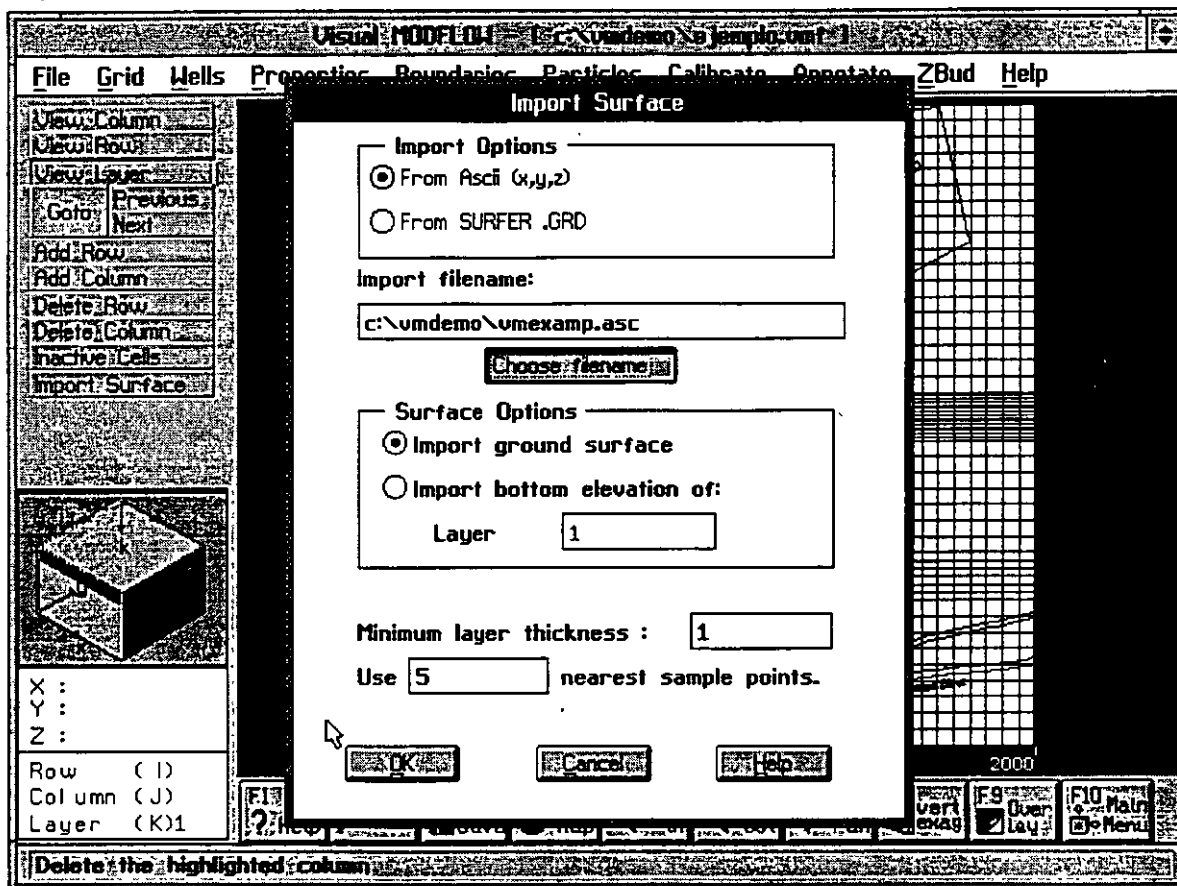
O.K.

O.K.

Esto importará una superficie con una pendiente que va de 18 metros al norte hasta 15 metros al sur (figura 7).



Figura 7. Superficie topográfica importada

6. ASIGNACION DE LOS VALORES DE CONDUCTIVIDAD HIDRAULICA, ALMACENAMIENTO Y RECARGA

VIEW LAYER

Seleccionar la capa superior y . Esto deberá de crear una vista aérea del lugar.

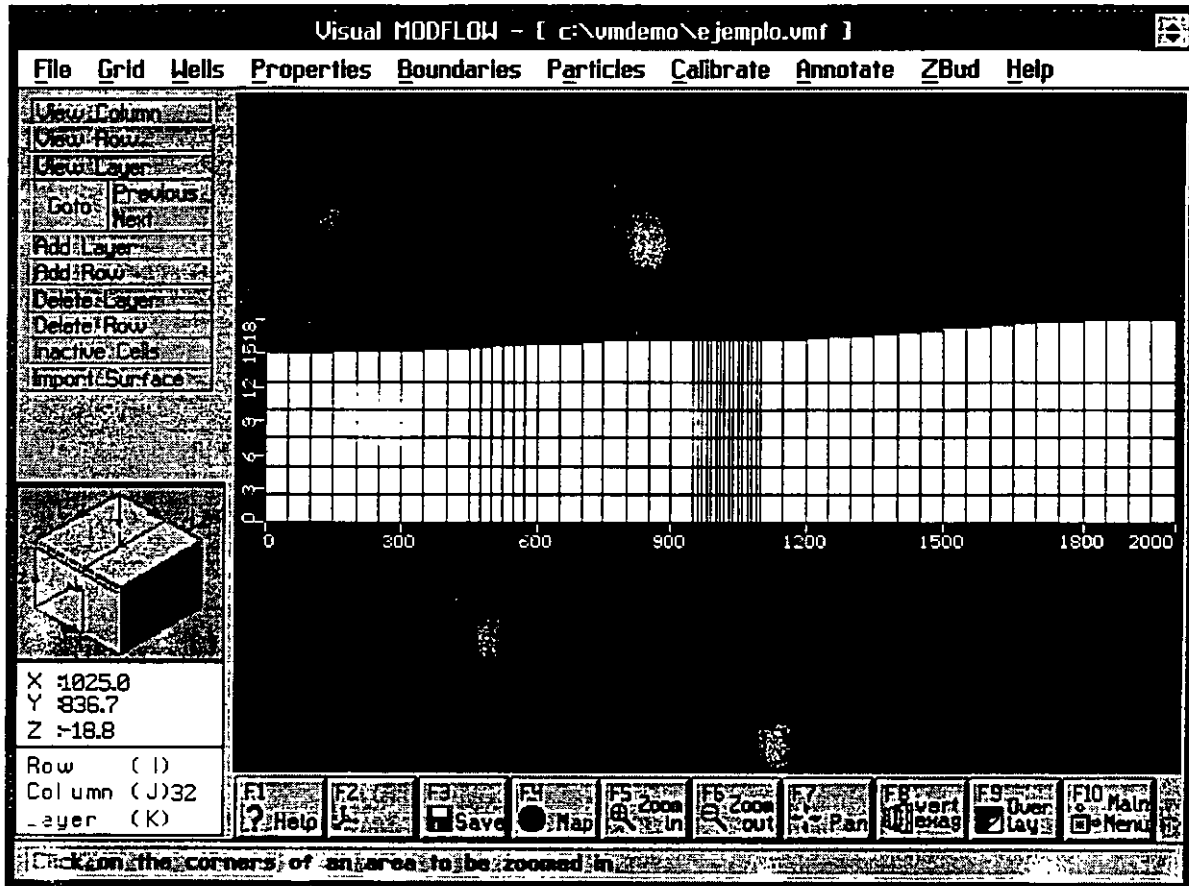
PROPERTIES (en el menú superior)

CONDUCTIVITY

En este momento el modelo preguntará si se desea salvar la información de la malla.

en YES

Hay que asegurarse de estar viendo la capa superior (capa 1). Esto se puede ver en el cubo que se encuentra en la parte inferior izquierda.

A continuación una ventana pide los valores que se asignarán como default a todas las celdas. Después se podrán modificar los valores a cada celda.

Conductividad hidráulica en X y Y (K_x y K_y) en m/s: **2e-4** ↵

Conductividad hidráulica en Z (K_z) en m/s: **2e-4** ↵

Coefficiente de almacenamiento (S_s) en 1/m: **1e-4** ↵

Rendimiento específico (S_y): **0.2** ↵

Porosidad (Por): **0.35** ↵

O.K.

Ahora se asignará el valor de conductividad hidráulica del acuitardo (capas 3 y 4).



GO TO (en el menú de la izquierda)

Aparecerá una ventana, escribir:

3 ↵

O.K.

ASSIGN WINDOW

Mover el mouse a la celda de la esquina superior izquierda y  en el centro de la celda. Después mover el mouse a la esquina inferior derecha y  en el centro de la celda. Esto creará una ventana que cubrirá toda la capa. Aparecerá una ventana para asignar la conductividad.

 NEW

Toda la malla cambiará a color azul. Asignar los valores de conductividad hidráulica del acuitardo:

$K_x \text{ (m/s)} = 1e-10$ 

(El valor de K_y será asignado automáticamente)

$K_z \text{ (m/s)} = 1e-10$ 

 O.K.

 COPY LAYER (del menú izquierdo)

Aparecerá una ventana, escoger:

 COPY ALL PROPERTIES (seleccionando el recuadro)

 LAYER 4 (le dará un color verdoso a la capa)



 O.K.

Ahora se asignarán los valores de almacenamiento al acuitardo.

 PROPERTIES (en el menú superior)

 ALMACENAMIENTO

 ASSIGN WINDOW

Mover el mouse a la celda de la esquina superior izquierda y  en el centro de la celda. Después mover el mouse a la esquina inferior derecha y  en el centro de la celda. Esto creará una ventana que cubrirá toda la capa. Aparecerá una ventana para asignar el almacenamiento.

 NEW (toda la malla cambiará a color azul)

Asignar los valores de almacenamiento y porosidad:

Ss (1/m): **1e-2** ↵

Sy: **0.003** ↵

Por: **0.65** ↵

↵ O.K.

↵ COPY LAYER (del menú izquierdo)

Aparecerá una ventana, escoger:

↵ COPY ALL PROPERTIES (seleccionando el recuadro)

↵ LAYER 4 (le dará un color verdoso a la capa)

↵ O.K.

Para comprobar los valores tanto de conductividad como de almacenamiento mediante ↵ en EDIT SINGLE, del menú izquierdo. Esto creará una ventana mostrando los valores de conductividad hidráulica y el almacenamiento para cada celda mediante un ↵ en ella.

Ahora se simulará el efecto de la perforación abandonada para ver el efecto en transporte.

↵ PROPERTIES

↵ CONDUCTIVITIES

↵ GO TO (Dar un valor de 1 para ir a la capa 1)

↵ O.K.

↵ ZOOM IN (Del menú inferior)

Hacer una ventana cerca de la perforación abandonada (*abandoned borehole*)

↵ ASSIGN SINGLE (Esto es para asignar propiedades a una sola celda)

Aparecerá una ventana de asignación (figura 8).



Figura 8. Asignando las propiedades a la perforación abandonada.

☞ NEW (Dará un color verde)

Asignar los siguientes valores:

$$K_x \text{ (m/s)} = 1e-1$$

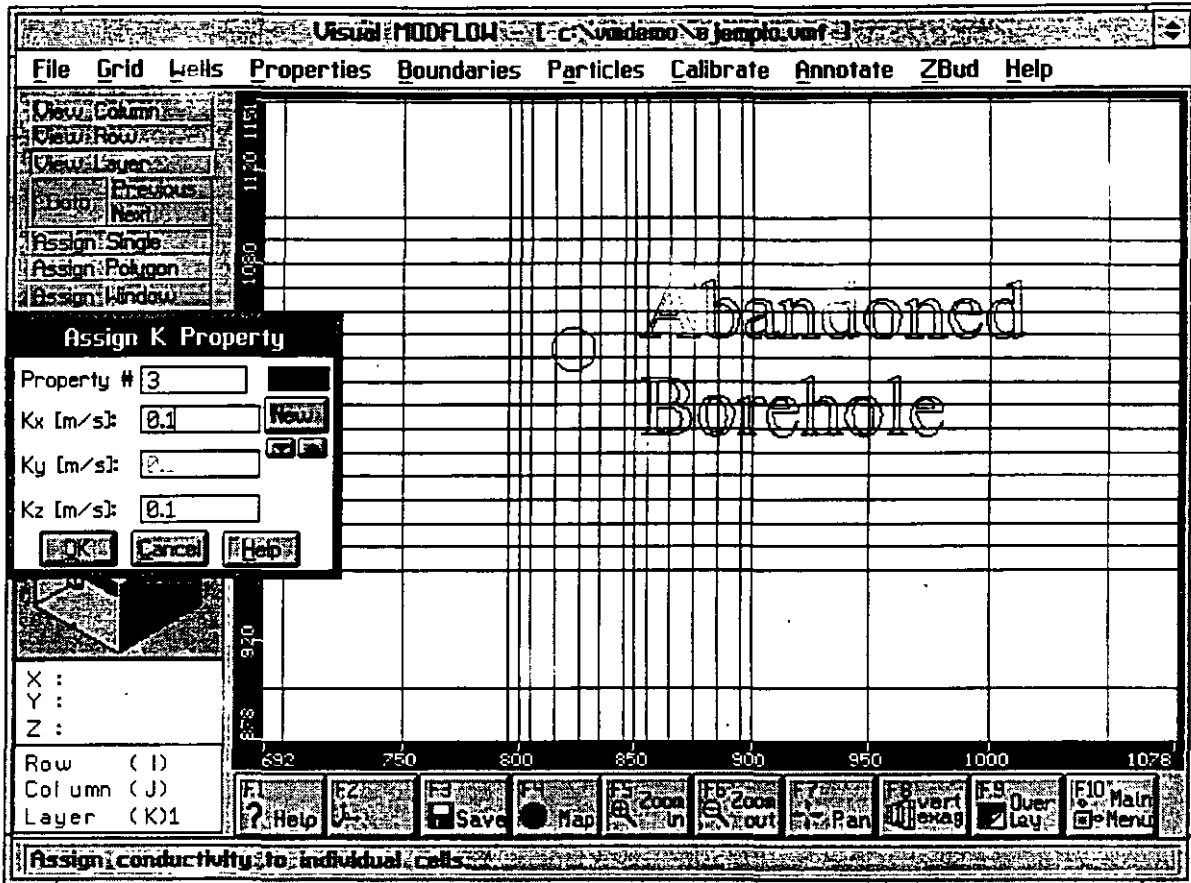
(El valor de K_y será asignado automáticamente)

$$K_z \text{ (m/s)} = 1e-1$$

☞ En el centro de la perforación abandonada (definida por el círculo) para designar la celda a la que se le asignarán las propiedades.

☞ O.K.

☞ COPY LAYER (del menú izquierdo)

Aparecerá una ventana, escoger:

☞ COPY ONLY PROPERTY #

Escribir:

3 ↵

☞ SELECT ALL

Todas las capas cambiarán de color (figura 9).

☞ O.K.

☞ ZOOM OUT



Figura 9. Copiando las propiedades de la perforación abandonada.

Ahora se le dará a la capa superior la recarga.

☞ . PROPERTIES

☞ RECHARGE

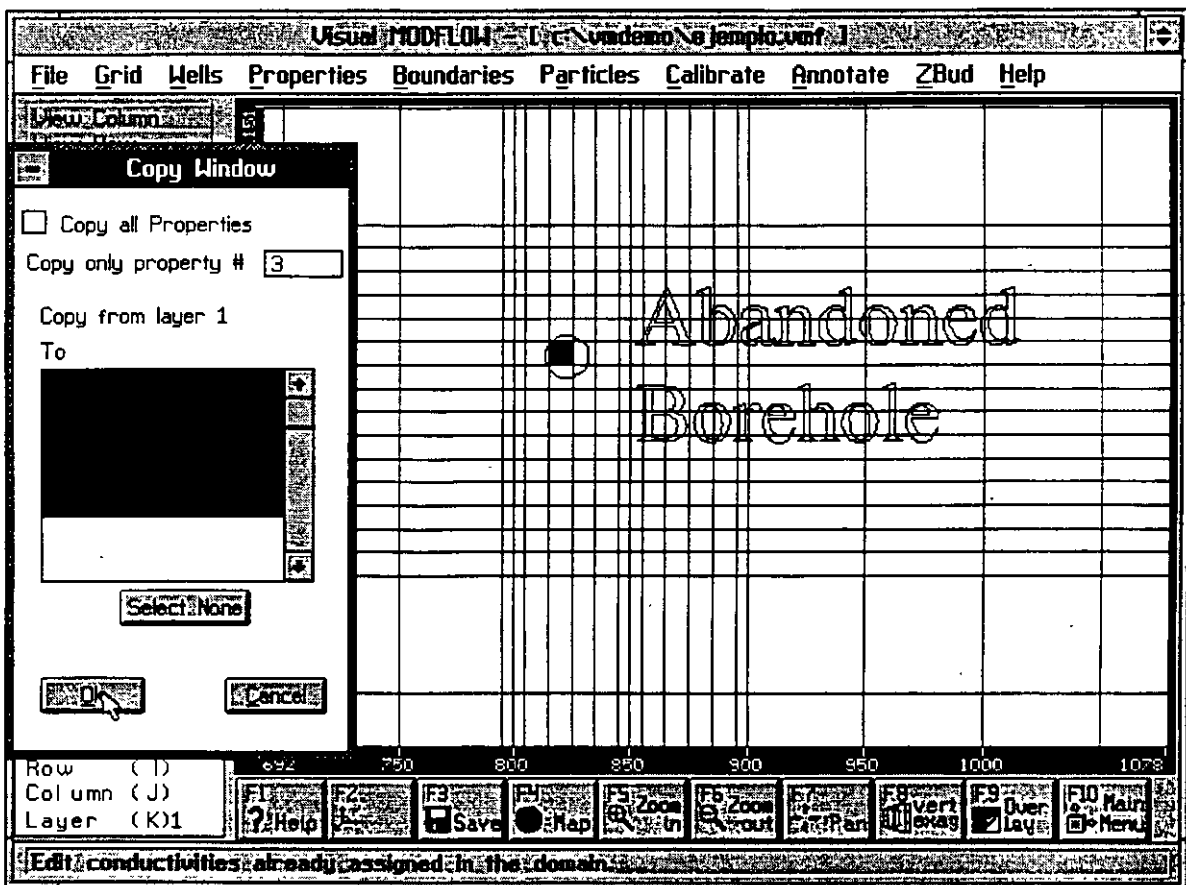
NOTA: En la nueva versión de Visual Modflow, tanto la recarga como la evapotranspiración, se encuentran en el menú de fronteras (*BOUNDARIES*) y no en el de propiedades.

Aparecerá una ventana para asignar el valor de recarga por default. Escribir:

100 ☞

☞ O.K.

Visual Modflow asigna automáticamente la recarga a la capa superior del modelo.

7. DELIMITACION DE LAS FRONTERAS DE FLUJO

BOUNDARIES

CONSTANT HEAD

Aparecerá una ventana preguntando si se desea salvar la información.

YES

ASSIGN LINE (del menú izquierdo)

Mover el mouse a la celda de la esquina superior izquierda y en el centro de la celda.

Después mover el mouse a la esquina **superior** derecha y **con el botón derecho** en el centro de la celda. Una línea horizontal de celdas cambiará a color rosa y aparecerá una ventana para asignar los valores de carga constante (figura 10). Asignar los siguientes valores:

Code #: **1**

en el cuadro de STOP TIME

Stop time: **3650**

Start point: **18**

End Point: **18**

O.K.

La línea rosa cambiará a color rojo indicando que la carga constante ha sido asignada.



Figura 10. Menú para la asignación de la carga constante

☞ COPY LAYER

Aparecerá la ventana para copiar propiedades. En el cuadro COPY ONLY CODE # ya tendrá el número 1.

☞ LAYER 2 (esto hará cambiar de color la capa 2)

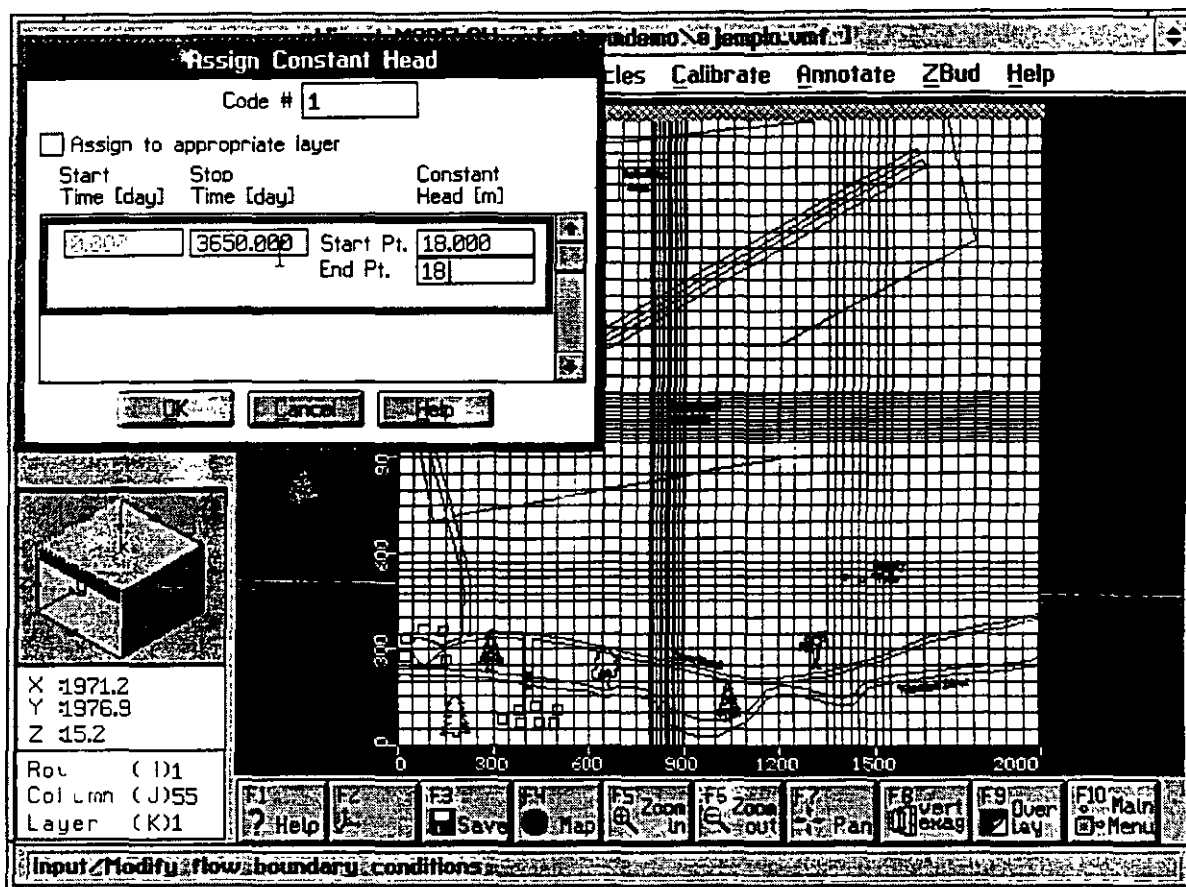
☞ O.K.

Ahora asignaremos los valores de carga constante del acuífero inferior.

☞ GO TO (en el menú de la izquierda)

Escoger:

5 ↵

☒ O.K.

☒ ASSIGN LINE

Mover el mouse a la celda de la esquina superior izquierda y ☒ en el centro de la celda. Después mover el mouse a la esquina **superior derecha** y ☒ **con el botón derecho** en el centro de la celda. Una línea horizontal de celdas cambiará a color rosa y aparecerá una ventana para asignar los valores de carga constante. Asignar los siguientes valores:

Code #: 2 ☒

☒ en el cuadro de STOP TIME

Stop time: 3650 ☒

Start point: 16.5 ☒

End Point: 16.5

☒ O.K.

La línea rosa cambiará a color rojo indicando que la carga constante ha sido asignada.

☒ COPY LAYER

Aparecerá la ventana para copiar propiedades. En el cuadro COPY ONLY CODE # reemplazar el valor tecleando el número 2.

☒ LAYER 6 (esto hará cambiar de color la capa 6)

☒ O.K.

☒ ASSIGN LINE

Mover el mouse a la celda de la esquina **inferior izquierda** y ☒ en el centro de la celda. Después mover el mouse a la esquina **inferior derecha** y ☒ **con el botón derecho** en el centro de la celda. Una línea horizontal de celdas cambiará a color rosa y aparecerá una ventana para asignar los valores de carga constante. Asignar los siguientes valores:

Code #: 3 ☒

☒ en el cuadro de STOP TIME

Stop time: 3650 ☒

Start point: 14.5 ☒

End Point: 14.5

☒ O.K.

La línea rosa cambiará a color rojo indicando que la carga constante ha sido asignada.

☒ COPY LAYER

Aparecerá la ventana para copiar propiedades. En el cuadro COPY ONLY CODE # reemplazar el valor tecleando el número 3.

☞ LAYER 6 (esto hará cambiar de color la capa 6)

☞ O.K.

Después de asignar los valores de carga constante:

☞ VIEW COLUMN

☞ en cualquier columna para ver una sección del modelo (figura 11).

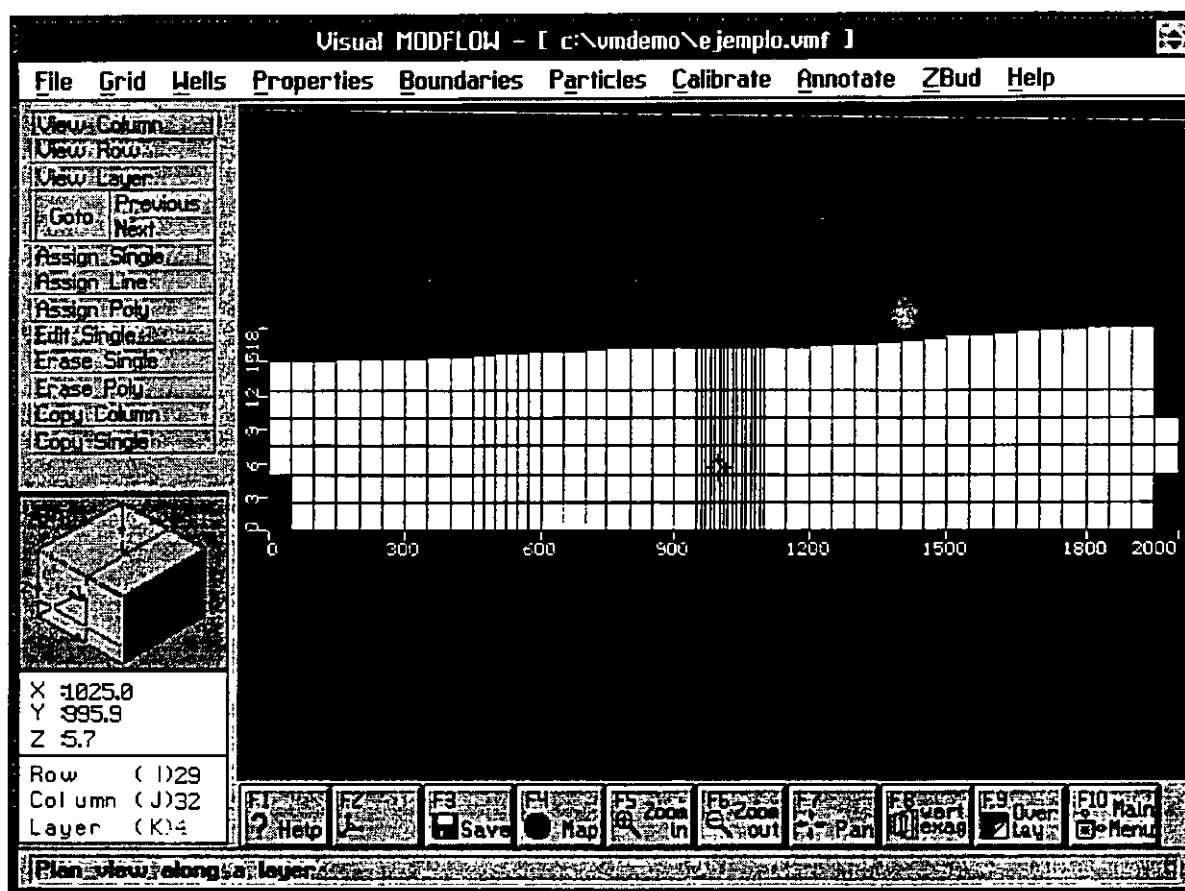

Figure 11. Fronteras de carga constante

Ahora asignaremos la frontera del río al sur de la zona.

☞ VIEW LAYER

- ☑ en la capa superior del modelo (capa 1)
- ☑ BOUNDARIES
- ☑ RIVERS
- ☑ ASSIGN LINE

Utilizando el plano base como guía se hay que digitalizar el río mediante ☑ comenzando desde el margen inferior izquierdo y tratando de seguir su contorno. Cuando se ha llegado al final (al margen inferior derecho) hay que ☑ en el botón derecho. Aparecerá una ventana para pedir la información del río (figura 12).



Figura 12. Ventana de información del río.

Asignar los siguientes valores:

Code #: 3 ↵

☞ en el cuadro de STOP TIME

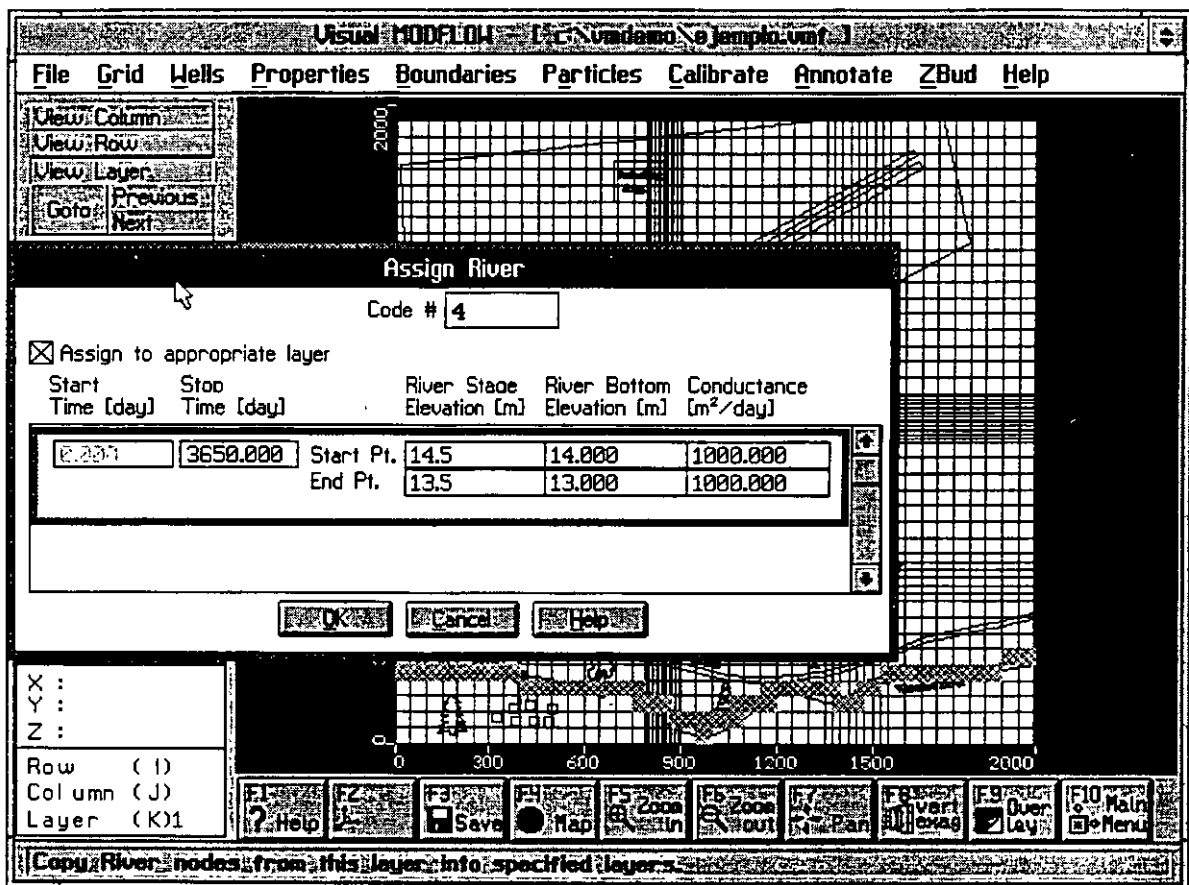
Stop time:	3650	☞
Start Point River Stage:	14.5	☞
Start Point River Bottom:	14.0	☞
Conductance:	1000	☞
End Point River Stage:	13.5	☞
End Point River Bottom:	13.0	☞
Conductance:	1000	

☞ O.K.

Después de que el río ha sido definido, una línea azul delimitará su extensión.

8. ASIGNACION DE PARTICULAS

Ahora asignaremos algunas partículas que emanen de la zona de tanques (*refueling area*) para delimitar el area de influencia que tienen estos tanques. Las partículas pueden ser de 2 tipos: *backward*, para delimitar el area de donde las partículas provienen; y *forward*, para delimitar el area hacia donde van las partículas.

NOTA: Esta manera de simular el movimiento de las partículas se realiza tomando en cuenta UNICAMENTE el flujo del agua subterránea. En la nueva versión del Visual Modflow se encuentra un paquete de simulación de movimiento de contaminantes mucho mas completo, llamado MT3D.

☞ PARTICLES

☞ YES (Para salvar la información de las fronteras)

☞ ADD CIRCLE

☞ En el centro del area de tanques (*refueling area*) que se encuentra en la porción centro-superior de la zona. Expandir el círculo que se forma hasta que cubra el recuadro del area de tanques y ☞. Aparecerá una ventana (figura 13) seleccionar:

☞ FORWARD

☞ O.K.



Figura 13. Agregando partículas

9. AGREGANDO POZOS

☑ WELLS

☑ YES (Para salvar la información de las partículas)

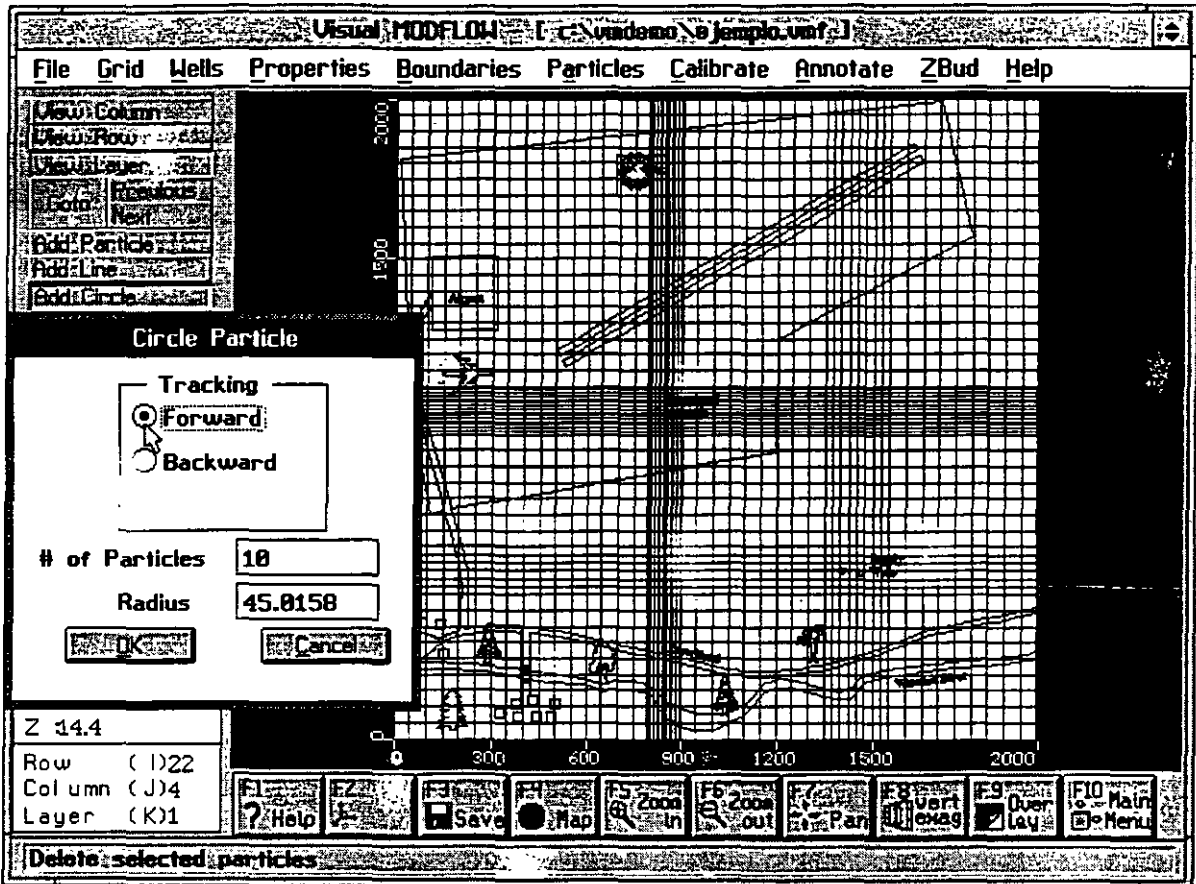
☑ ZOOM IN (F5)

☑ cerca de los pozos de abastecimiento de agua (*supply wells*) y hacer una ventana que los abarque volviendo a ☑ para conseguir un acercamiento de la zona.

☑ ADD WELL

Mover el cursor al centro del pozo de la izquierda y ☑ en él. Aparecerá una ventana con la información del pozo (figura 14).

Visual MODFLOW [c:\vmodemo\ejemplo.vmf]

Well Edit Window

Well name
POZO 1

X Location
1485.98 [m]

Y Location
525.31 [m]

Add Screen Clear Screen
Clear all Screen all

Screen from:
5.00 [m]

To
8.00 [m]

Well casing display as:
Elevation

Pumping Schedule

Start [day]	Stop [day]	Rate [m ³ /d]
0.000	3650.000	-200.000

OK Cancel Help

Deactivate Well

Input the start, elevation/depth of a screened interval

Figura 14. Información del pozo

Agregar la siguiente información:

Well Name: **POZO 1**

Stop Day: **3650**

Rate: **-200**

NOTA: El bombeo del pozo debe de ser de **negativo**. Si el pozo es de inyección el signo debe ser **positivo**.

⌘ ADD SCREEN

Estos pozos deberán estar ranurados solo en el acuífero inferior, que son los últimos 5 metros del modelo. ⌘ dentro del pozo a una elevación aproximada de 5 metros, y hay que mover la barra roja hasta la base del pozo y ⌘ otra vez. Los últimos 5 metros del pozo deben de haber cambiado de color representando el intervalo ranurado.

⌘ O.K.

⌘ COPY WELL

Mover el cursor hasta que esté posicionado sobre el pozo izquierdo y ⌘, después mover el cursor al pozo de la derecha y ⌘ en él para copiar el pozo.

⌘ EDIT WELL

⌘ El pozo de la derecha

Cuando aparezca el menú cambiar el nombre del pozo por **POZO 2** y ⌘ en O.K.

⌘ MAIN MENU (F10) (Del menú inferior)

⌘ YES (para salvar la información de los pozos)

10. PARA CORRER VISUAL MODFLOW

☞ RUN

☞ O.K. (para aceptar el estado estacionario)

☞ RUN MODEL

NOTA: La versión de Visual Modflow que se les ha entregado es un DEMO de práctica que no tiene la capacidad de correr el modelo.

Aparece una ventana para definir que es lo que se va a correr (figura 15).



Figura 15. Corriendo el Visual Modflow

☞ en el recuadro de MODFLOW

☞ en el recuadro de MODPATH

☞ O.K.

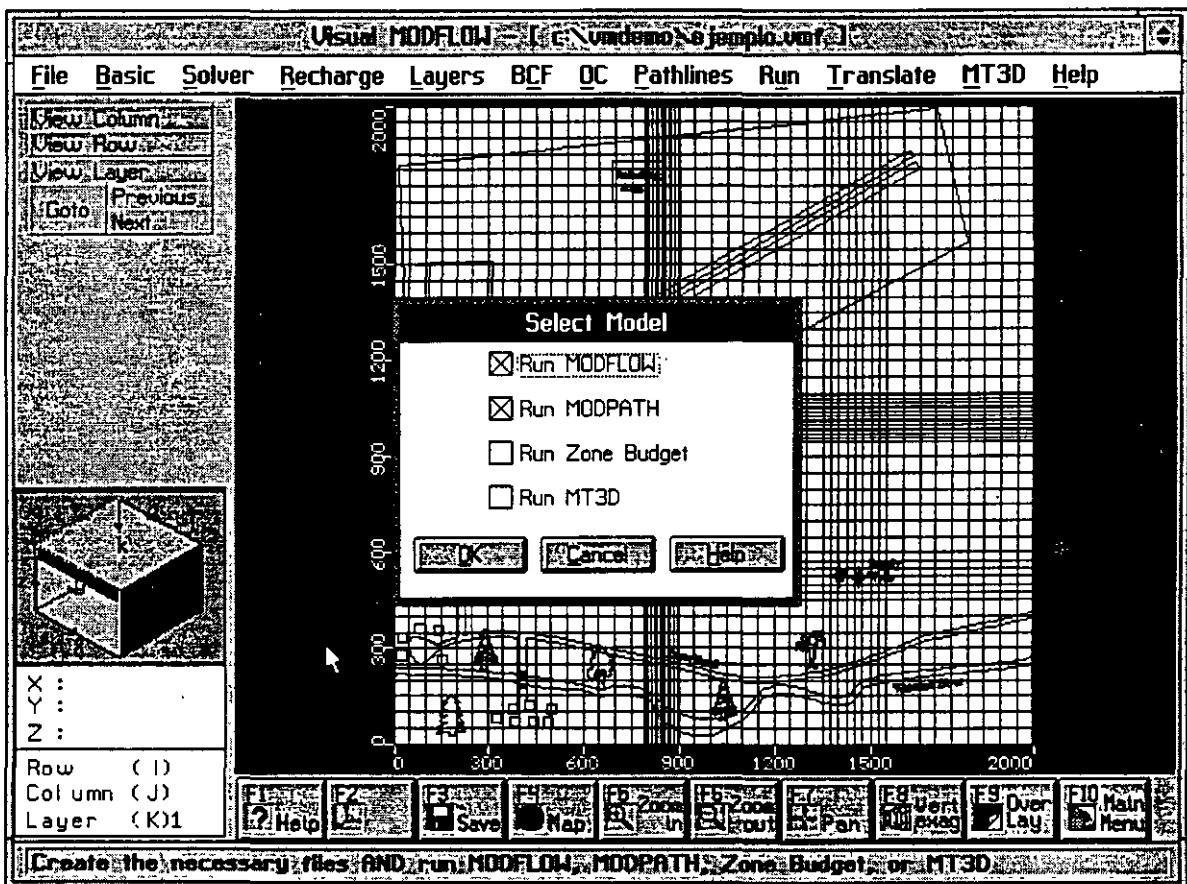
11. VISUALIZACION DE LOS RESULTADOS

OUTPUT

Esto nos permite ver los niveles piezométricos calculados para el acuífero superior (figura 16).



Figura 16. Niveles piezométricos

☞ PATHLINES (del menú superior)

Esto nos permite ver el movimiento de las partículas (figura 17).

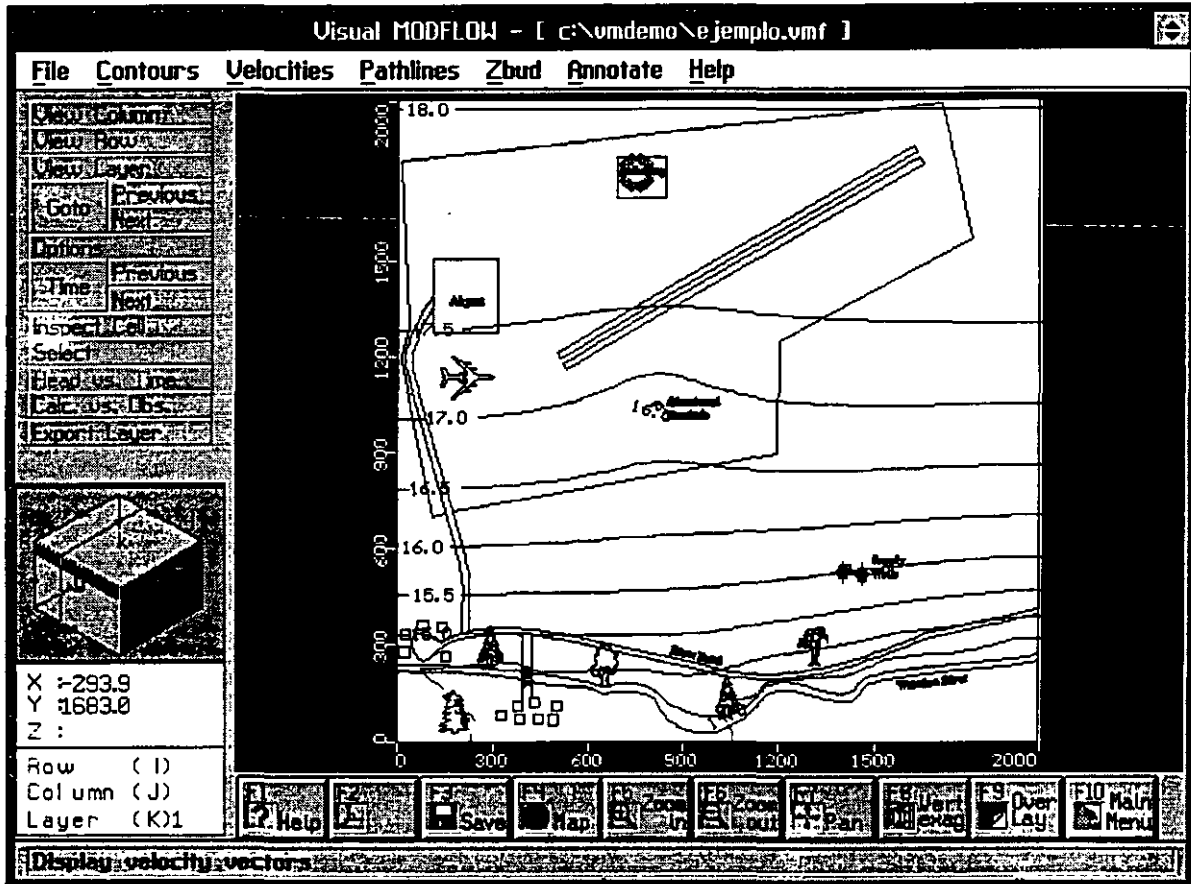

Figura 17. Movimiento de las partículas

☞ VIEW COLUMN

Mover el cursor hacia alguna columna cerca de la perforación abandonada y ☞. Esto nos dará una visión de la sección del modelo (figura 18).

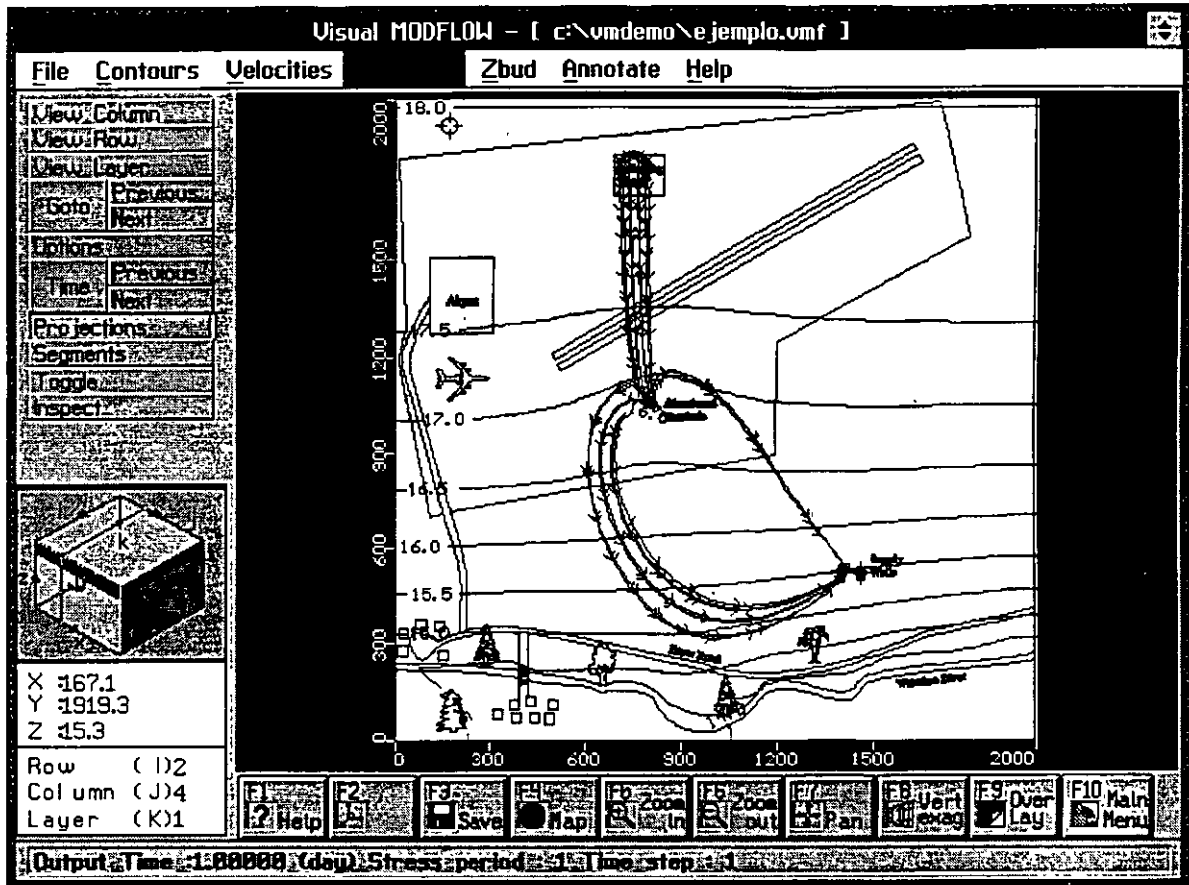

Figura 18. Movimiento de las partículas en sección

La figura 19 muestra en un acercamiento del movimiento de las partículas, y se aprecia como es que la contaminación del acuífero superior puede llegar a los pozos de abastecimiento que bombean del acuífero inferior por medio de la perforación abandonada.

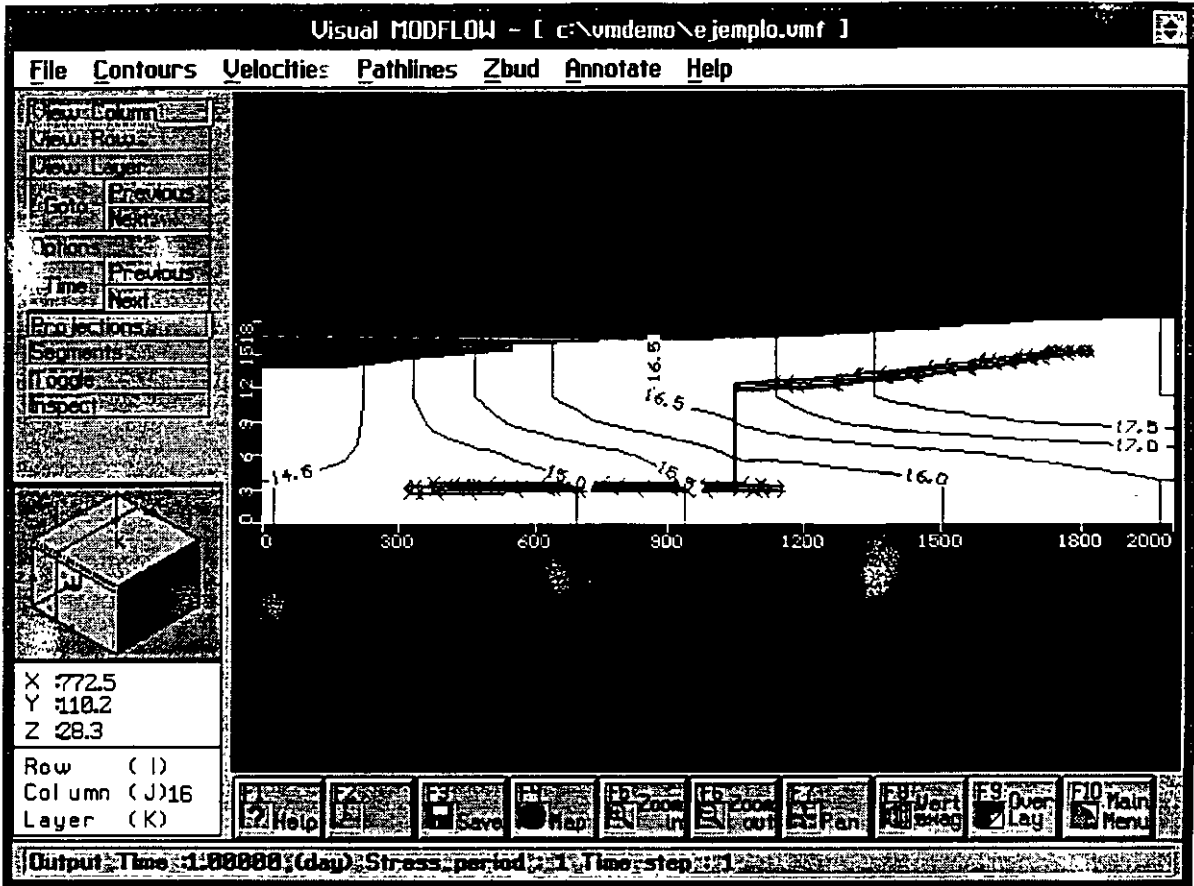

Figura 19. Movimiento de las partículas a través de la perforación abandonada.

Las figuras 20 y 21 muestran el resultado si la conductividad hidráulica que simula la perforación abandonada no hubiera sido tomada en cuenta. Este resultado predeciría que la contaminación permanecería en el acuífero superior sin infiltrarse por la perforación abandonada. De esta manera se predeciría erróneamente que los pozos de abastecimiento no se contaminarían.



Figura 20. Movimiento de partículas cuando no se toma en cuenta la perforación abandonada.

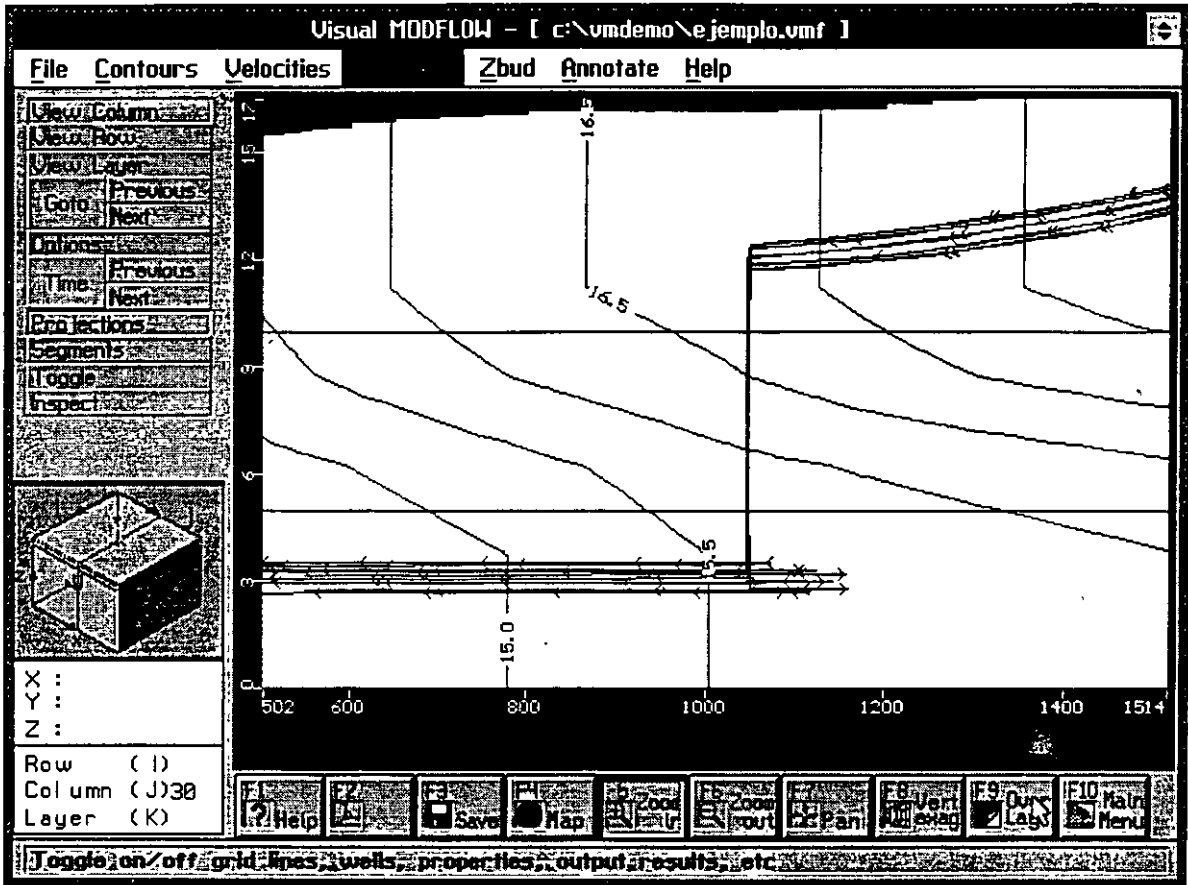

Figura 21. Sección mostrando que el movimiento de las partículas está restringido al acuífero superior, cuando no se toma en cuenta la infiltración por medio de la perforación abandonada.

- ☞ MAIN MENU (del menú superior)
- ☞ FILE
- ☞ EXIT.

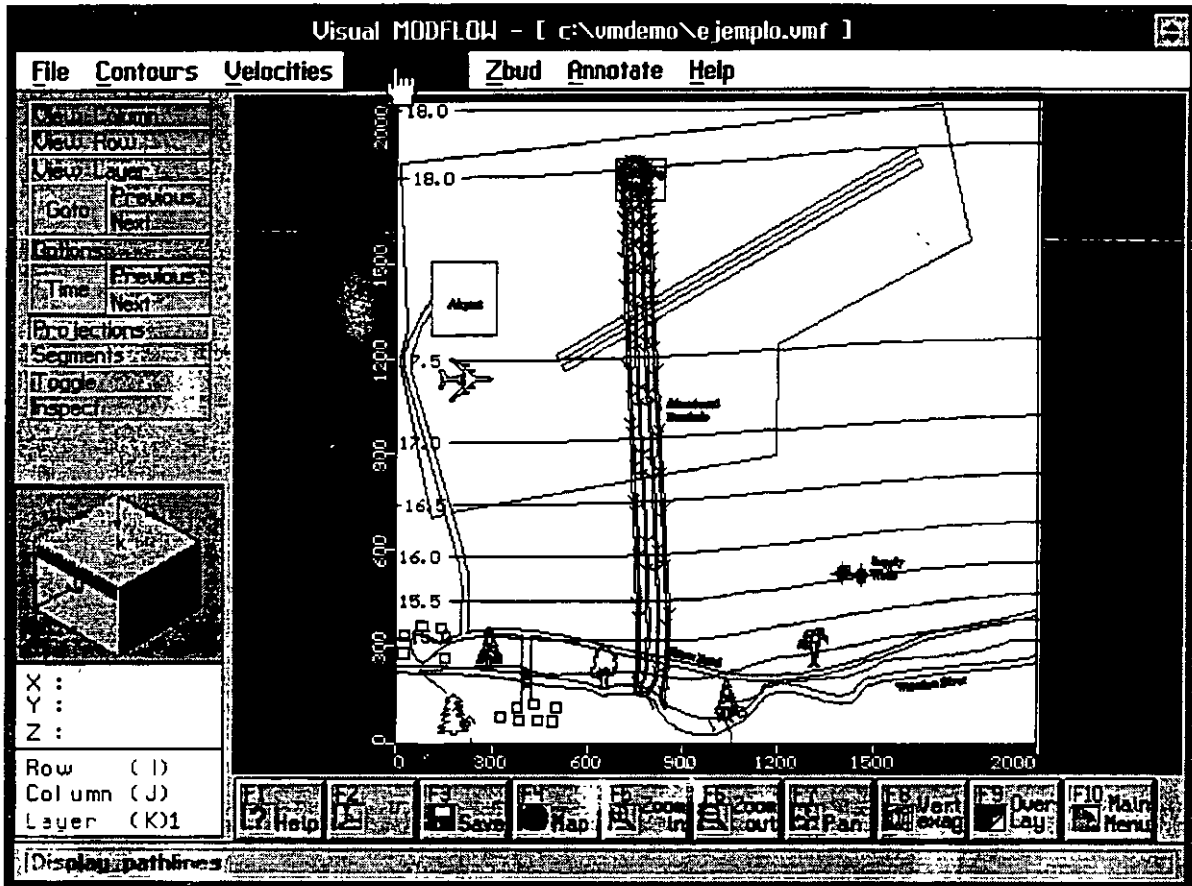
DATOS DEL ARCHIVO VMEXAMP.ASC

0 0 15.2
1000 0 15.1
2000 0 15.0
0 1000 16.3
1000 1000 16.2
2000 1000 16.1
0 2000 18.2
1000 2000 18.1
2000 2000 18.0

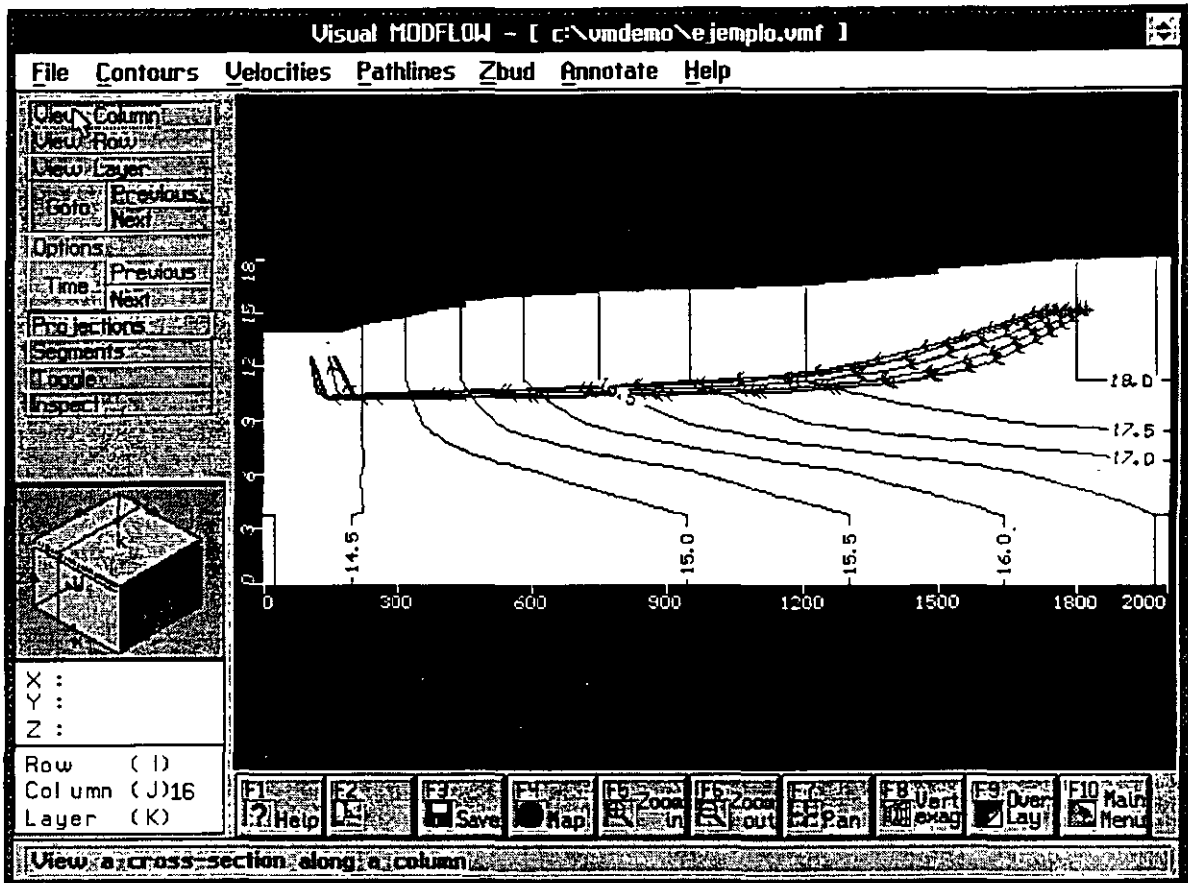

**FACULTAD DE INGENIERIA U.N.A.M.
DIVISION DE EDUCACION CONTINUA**

CURSOS ABIERTOS

**“ IX CURSO INTERNACIONAL DE
CONTAMINACIÓN DE ACUÍFEROS “**

MODULO III

MODELOS MATEMÁTICOS EN GEOHIDROLOGÍA

TEMA

**MODELOS MATEMÁTICOS Y
COMPUTACIÓN APLICADA
A LA GEOHIDROLOGÍA**

**EXPOSITOR: ING. JUAN MANUEL LESSER ILLADES
1997**

1560 Lincoln Road
Columbus, Ohio 43212-2722
U.S.A.

Chair: Gary D. Moore
Vice Chair: Nilson Guiguer



International Association of Hydrogeologists Commission on Hydrogeology and Computers

Tel: +614 276 8123

Fax: +614 276 8123

Email: GMoore6751@aol.com

DISCLAIMER

The International Association of Hydrogeologists (IAH) assume no responsibility and shall have no liability resulting from the use of the Ground Water for Windows (GWW) software.

In distributing this software, IAH makes no offer of user support. The users of GWW are encouraged to become thoroughly familiar with the detailed documentation included with the software.

A limited number of copies of the GWW software and manual is being distributed by IAH to its members in developing nations funded by the IAH Developing Nations Program Fund. The GWW software is non-copyrighted and can be freely copied and distributed with proper acknowledgment given to the United Nations.

Significant flaws in the software should be reported to the Chief, Natural Resources, Environment, Planning, and Management Branch, United Nations, New York, New York, 10017, USA, so that future versions can benefit.

Dr. John E. Moore
IAH President
September, 1995

SPECIAL NOTE

The installation of Ground Water for Windows (GWW) on your computer hard drive requires that specific adjustments be made to both your config.sys and autoexec.bat files. For those users who are not familiar with how to edit these files, follow the instructions given below. The **bold print** below indicates what you should enter using the key board.

To edit your autoexec.bat file in Microsoft Windows™:

1. In Program Manager, open Accessories Group.
2. Open Notepad
3. Select File
4. Select Open
5. List all files by typing *.*
6. Under Directories select C:\
7. Select autoexec.bat file
8. At line path=C: add to file ;C:\GWW
At the end of your autoexec.bat file add the line **SET GWW=C:\GWW**
9. Select File and Save
10. Exit and reboot your system

Example of autoexec.bat file (bold entries show location of file additions)

```
C:\WINDOWS\net start
C:\WINDOWS\SMARTDRV.EXE /X 1024 128
PROMPT $p$g
SET PATH=C:\MOUSE;C:\WINDOWS;C:\DOS;C:\HDM;C:\AOL;C:\GWW
MOUSE
SET TEMP=C:\DOS
SET GWW=C:\GWW
```

To edit your config.sys file in Microsoft Windows™

1. In Program Manager, open Accessories Group
2. Open Notepad
3. Select File
4. Select Open
5. List all files by typing *.*
6. Under Directories select C:\
7. Select config.sys file
8. Change your file so that it contains:
Files=**70**
Buffers=**10**
9. Select File and Save
10. Exit and reboot your system

Example of config.sys file (bold entries show location of file changes)

```
BUFFERS = 30
DEVICE=C:\WINDOWS\HIMEM.SYS
device=c:\dos\emm386.exe x=c800-cbff
DOS=HIGH
FILES=70
rem LASTDRIVE=P
DEVICE=C:\WINDOWS\VFSLP.SYS
STACKS=9,256
```

Table of Contents

CHAPTER 1	INTRODUCTION	1-1
1.1.	ACKNOWLEDGMENT	1-1
1.2.	DISCLAIMER	1-2
1.3.	TYPOGRAPHICAL CONVENTIONS	1-3
1.4.	CONTENT OF THE GWW PACKAGE	1-4
1.5.	HARDWARE REQUIREMENTS	1-5
1.6.	SOFTWARE REQUIREMENTS	1-7
1.7.	FEATURES AND LIMITATIONS	1-8
1.8.	PRE-INSTALLATION	1-11
1.9.	INSTALLATION	1-12
1.10.	STARTING THE PROGRAM	1-13
1.11.	HELP	1-15
1.12.	WINDOWS BASICS	1-17

CHAPTER 2	DATA BASE STRUCTURE	2-1
2.1.	BASIC CONCEPTS OF GWW DATA AND FORMS STRUCTURE	2-1
2.1.1.	Objects In GWW	2-1
2.1.2.	Foreign Languages	2-1
2.1.3.	GWW Forms	2-2
2.1.4.	Relational Data Base	2-3
2.1.5.	Data Base	2-3
2.1.6.	File	2-3
2.1.7.	Fields	2-4
2.1.8.	Field Types	2-4
2.1.9.	Text Field	2-4
2.1.10.	Text Field Attributes	2-5
2.1.11.	Data Field	2-5
2.1.12.	Data Field Attributes	2-5
2.1.13.	Drawing Field	2-6
2.1.14.	Column Field	2-6
2.1.15.	Field Name	2-6
2.1.16.	Border	2-7
2.1.17.	Background	2-7

Table of Contents

2.1.18.	Field Label	2-7
2.1.19.	Label Font	2-7
2.1.20.	Label Color	2-8
2.1.21.	Label Alignment	2-8
2.2.	DATA BASE STRUCTURE	2-8
2.2.1.	Data Base Structure Concept	2-8
2.2.2.	Data Base Content	2-10
2.3.	EXAMPLE OF CREATING A NEW DATA FILE STRUCTURE	2-11
2.3.1.	Getting Started	2-11
2.3.3.	Editing an Existing Data File Structure	2-14
2.4.	FURTHER OPTIONS ON DATA STRUCTURE FILE MENU	2-21
2.4.1.	Writing Data Structure to Standard ASCII Files	2-21
2.4.2.	Creating Data Structure from Standard ASCII Files	2-23

CHAPTER 3 FORMS 3-1

3.1.	CONCEPT OF FORMS	3-1
3.1.1.	General	3-1
3.1.2.	Entry Form Screen	3-2
3.1.3.	Entry Form Selection	3-3
3.1.4.	Content of a Form	3-4
3.2.	STANDARD FORMS	3-5
3.3.	REPORTING FORMS	3-7
3.3.1.	Types of Reporting Forms	3-7
3.3.2.	Single Record Forms	3-7
3.3.3.	Group Record Form	3-8
3.3.4.	Hydrograph Report	3-8
3.3.5.	Hydrograph General Table Report	3-8
3.4.	FORM EDITOR	3-9
3.4.1.	Elements of a Form	3-9
3.4.2.	Adding Field to a Form	3-11
3.4.3.	Text Field Attributes	3-11
3.4.4.	Field Name	3-11
3.4.5.	Border	3-12
3.4.6.	Background	3-12
3.4.7.	Field Label	3-12
3.4.8.	Label Font	3-12
3.4.9.	Label Color	3-13
3.4.10.	Label Alignment	3-13
3.4.11.	Options	3-13
3.5.	CREATING A NEW FORM	3-13
3.6.	SELECTING AND EDITING AN OLD FORM	3-14
3.7.	READING FROM AND WRITING TO AN ASCII FILE DATA ENTRY FORM	3-15
3.7.1.	Reading From an ASCII File	3-15
3.7.2.	Writing to an ASCII File	3-15

3.8.	PRINTING AN ENTRY FORM	3-16
3.9.	EXAMPLES	3-17
3.9.1.	Create a New Master Data Entry Form	3-17
3.10.	NONSTANDARD FORMS	3-24

CHAPTER 4 UNITS 4-1

4.1.	GENERAL	4-1
4.1.1.	Unit Type	4-1
4.1.2.	Units	4-1
4.1.3.	Conversion Factor	4-1
4.1.4.	Basic Units	4-2
4.2.	WORK WITH UNITS	4-2
4.2.1.	Units as a Tool	4-2
4.2.2.	Modifying Unit Type	4-4
4.2.3.	Adding New Unit	4-4
4.3.	UNIT CONVERSION UTILITY	4-7
4.4.	USING UNIT SYSTEM OTHER THAN PRE-PROGRAMMED FOR GWW	4-8
4.5.	UNITS IN INDIVIDUAL APPLICATIONS	4-10

CHAPTER 5 COMMON ROUTINES 5-1

5.1.	GENERAL	5-1
5.2.	UNITS	5-2
5.3.	SELECTION OF WELLS OR SAMPLES OR REDUCTION OF A LARGE DATA SET TO A SMALLER SUBSET	5-6
5.3.1.	Select Condition	5-6
5.3.2.	Selection from a Map	5-10
5.3.3.	Selection of Wells One by One	5-14
5.3.4.	Working Group	5-15
5.4.	SETTING UP PRINTER	5-16
5.5.	READING FROM STANDARD ASCII FILE OR WRITING TO STANDARD ASCII FILE	5-17
5.6.	CREATING RANDOM MODELS	5-23
5.7.	EDITING A TABLE AND ATTEMPTING TO ESCAPE WITHOUT COMPLETING EDITING	5-25

CHAPTER 6 MASTER DATA APPLICATION 6-1

6.1.	GENERAL	6-1
6.2.	RELATIONSHIP BETWEEN MASTER DATA AND OTHER APPLICATIONS	6-2
6.3.	ENTERING INFORMATION	6-3
6.4.	OPTIONS ON THE MENU BAR	6-4

Table of Contents

6.4.1.	Data Submenu	6-4
6.4.2.	Units	6-5
6.4.3.	Report	6-5
6.4.4.	Make Random	6-7
6.4.5.	Load Map	6-8
6.4.6.	Help	6-8

CHAPTER 7 CHEMISTRY APPLICATION 7-1

7.1.	GENERAL	7-1
7.2.	MAIN MENU BAR AND MAJOR OPTIONS	7-1
7.3.	DATA SUBMENU	7-3
7.4.	DIAGRAMS	7-4
7.4.1.	Stiff Diagram	7-4
7.4.2.	Piper Diagram	7-5
7.4.3.	Wilcox Diagram	7-6
7.4.4.	Schoeller Diagram	7-7
7.5.	TABLES	7-7
7.6.	REPORTS	7-9
7.7.	OPTIONS	7-10
7.8.	MAP	7-12
7.9.	MAKE RANDOM	7-13
7.10.	HELP	7-14
7.11.	EXAMPLE	7-14
7.11.1.	Create a New Data File Structure	7-15
7.11.2.	Create a New Entry Form	7-16
7.11.3.	Create Data Base Entry	7-17

CHAPTER 8 WELL LOGS & LITHOLOGY 8-1

8.1.	GENERAL	8-1
8.2.	OPTIONS ON THE MENU BAR	8-2
8.3.	DATA	8-3
8.4.	EDITING WELL LOG DATA	8-6
8.4.1.	Editing Existing Data	8-6
8.4.2.	Creating a New Log	8-9
8.5.	LITHOLOGIC UNITS	8-9
8.5.1.	Read In File with Symbols for Lithologic Units	8-10
8.5.2.	Edit Lithologic Symbols and Descriptions	8-11
8.5.3.	Deleting Lithological Units	8-12
8.6.	CONSTRUCTION DATA	8-14
8.6.1.	Annulus	8-15
8.6.2.	Hole	8-15
8.6.3.	Casing	8-16

8.6.4.	Screen	8-16
8.6.5.	Construction Units	8-16
8.6.6.	Annulus Materials	8-17
8.7.	DISPLAY	8-17
8.8.	REPORT	8-19
8.9.	LOAD MAP	8-20
8.10.	MAKE RANDOM	8-20
8.11.	HELP	8-21
8.12.	EXAMPLE	8-21

CHAPTER 9 PUMPING TEST APPLICATION 9-1

9.1.	INTRODUCTION	9-1
9.1.1.	General	9-1
9.1.2.	Features Of The Interpretation Mode	9-2
9.1.3.	Input Data Conventions	9-3
9.1.4.	Aquifer Parameters	9-5
9.1.5.	Units	9-6
9.2.	MAIN MENU BAR	9-7
9.3.	DATA	9-9
9.4.	EDITING PUMP TEST DATA	9-11
9.4.1.	Measurements Units	9-11
9.4.2.	Edit Attributes	9-11
9.4.3.	Edit Measurements	9-12
9.4.4.	Standard ASCII Input	9-13
9.4.5.	Standard ASCII Output	9-14
9.5.	FITTING	9-15
9.6.	DISPLAY	9-16
9.7.	REPORTING	9-18
9.8.	MAKE RANDOM	9-21
9.9.	LOAD MAP	9-21
9.10.	HELP	9-21
9.11.	EXAMPLE	9-22

CHAPTER 10 HYDROGRAPHS APPLICATION 10-1

10.1.	INTRODUCTION	10-1
10.1.1.	General	10-1
10.2.	MAIN MENU BAR	10-1
10.2.1.	Components of the Hydrograph Application	10-1
10.2.2.	Entry Form	10-3
10.3.	DATA	10-3
10.3.1.	Options on the Data Menu	10-3
10.3.2.	Select Working Set	10-4
10.3.3.	Delete Record	10-4

Table of Contents

10.3.4.	Select Entry Form	10-4
10.3.5.	General Data Units	10-5
10.3.6.	Working Time Interval	10-6
10.3.7.	Standard ASCII Input	10-7
10.3.8.	Standard ASCII Output	10-8
10.3.9.	Print Setup	10-8
10.4.	WATER LEVELS	10-8
10.4.1.	· Edit Water Level Data	10-8
10.4.2.	Selecting Levels or Depth to Water Level	10-9
10.4.3.	Depth or Level Units	10-10
10.5.	DISPLAY	10-10
10.6.	REPORTING	10-11
10.7.	MAKE RANDOM	10-12
10.8.	LOAD MAP	10-13
10.9.	INTERPOLATION	10-13
10.9.1.	Connection Interval	10-13
10.9.2.	Interpolation Date	10-14
10.10.	HELP	10-15
10.11.	EXAMPLE	10-15

CHAPTER 11 STEP DRAWDOWN TEST APPLICATION 11-1

11.1	INTRODUCTION	11-1
11.1.1.	General	11-1
11.2.	MAIN MENU BAR	11-2
11.2.1.	Components of the Step Drawdown Test Application	11-2
11.2.2.	Entry Form	11-3
11.3.	DATA	11-3
11.3.1.	Options on the Data Menu	11-3
11.3.2.	Select Working Set	11-4
11.3.3.	Delete Record	11-4
11.3.4.	Select Entry Form	11-4
11.3.5.	General Data Units	11-5
11.3.6.	Print Setup	11-5
11.4.	EDIT DATA MENU	11-5
11.4.1.	Edit Data Submenu	11-5
11.4.2.	Measurements Units	11-6
11.4.3.	Entering Data	11-6
11.5.	FITTING	11-7
11.6.	DISPLAY	11-9
11.7.	REPORTING	11-10
11.8.	MAKE RANDOM	11-11
11.9.	LOAD MAP	11-12

11.10.	HELP	11-12
11.11.	EXAMPLE	11-12

CHAPTER 12 GRAIN SIZE CURVE APPLICATION 12-1

12.1.	INTRODUCTION	12-1
12.1.1.	General	12-1
12.2.	MAIN MENU BAR	12-1
12.2.1.	Components of the Grain Size Curve Application	12-1
12.2.2.	Entry Form	12-2
12.3.	DATA	12-2
12.3.1.	Options on the Data Menu	12-2
12.3.2.	Select Working Set	12-3
12.3.3.	Delete Record	12-3
12.3.4.	Select Entry Form	12-3
12.3.5.	General Data Units	12-4
12.3.6.	Print Setup	12-4
12.4.	EDIT DATA MENU	12-4
12.4.1.	Edit Data Submenu	12-4
12.4.2.	Number of Data Sets	12-5
12.4.3.	Data Entry Table	12-6
12.5.	DISPLAY	12-7
12.6.	REPORTING	12-7
12.7.	LOAD MAP	12-8
12.8.	HELP	12-8
12.9.	ADDING OR DELETING SAMPLES	12-8
12.10.	EXAMPLE	12-9

CHAPTER 13 MISCELLANEOUS APPLICATION 13-1

13.1.	INTRODUCTION	13-1
13.1.1.	General	13-1
13.2.	APPLICATION'S CONTENT	13-1
13.3.	WELL FUNCTIONS	13-1
13.3.1.	Non-Leaky Well Function	13-2
13.3.2.	Leaky Well Function	13-4
13.4.	GRAIN SIZE ANALYSIS	13-6
13.5.	WELL CONSTRUCTION	13-9

Table of Contents

CHAPTER 14	CROSS SECTIONS	14-1
14.1.	INTRODUCTION	14-1
14.1.1.	General	14-1
14.1.2.	Application's Content	14-1
14.2.	CROSS SECTION	14-2
14.2.1.	New Cross Section	14-4
14.2.2.	New Cross Section Like ...	14-5
14.2.3.	Old Cross Section	14-5
14.2.4.	Clear Cross Section	14-6
14.2.5.	Save Cross Section	14-6
14.2.6.	Save Cross Section As ...	14-6
14.2.7.	Edit Parameters	14-7
14.2.8.	Make Legend	14-8
14.2.9.	Write Text to Legend	14-8
14.2.10.	Write Scale to Legend	14-8
14.2.11.	Print Cross Section	14-8
14.2.12.	Print Setup	14-8
14.2.13.	Dimension	14-9
14.3.	ADDING WELLS TO A CROSS SECTION	14-9
14.3.1.	Select Working Set	14-10
14.3.2.	Select Working Group	14-10
14.3.3.	Select Working Group Within Range	14-10
14.3.4.	Add Wells to Cross Section	14-11
14.3.5.	Add Lithology to Legend	14-12
14.4.	MAP	14-12
14.5.	ADDING WELLS BY DRAWING CROSS SECTION LINE ON THE MAP	14-15
14.6.	CREATING CROSS SECTION WITH SELECTED WELLS	14-17
14.7.	ADDING INTERSECTION LINES	14-19
14.7.1.	Grid Model Menu	14-19
14.7.2.	Get Intersection Line	14-20
14.7.3.	Edit Line Attributes	14-20
14.7.4.	Plot Intersection Line	14-22
14.8.	LEGEND	14-22
14.9.	OPTIONS	14-24
14.9.1.	Column Plotting Style	14-26
14.9.2.	Edit Chemical Concentration Parameters	14-27
<hr/>		
CHAPTER 15	MAPPING APPLICATION	15-1
15.1	INTRODUCTION	15-1
15.1.1.	General	15-1
15.1.2.	Application's Content	15-1
15.2.	MAP	15-3

15.2.1.	New Map	15-4
15.2.2.	New Map Like ...	15-5
15.2.3.	Old Map	15-6
15.2.4.	Clear Map	15-7
15.2.5.	Save Map	15-7
15.2.6.	Save Map As ...	15-7
15.2.7.	Make Legend	15-8
15.2.8.	Write Text to Legend	15-9
15.2.9.	Write Scale to Legend	15-9
15.2.10.	Edit Parameters	15-9
15.2.11.	Print Map	15-10
15.2.12.	Print Setup	15-10
15.2.13.	Dimension	15-10
15.2.14.	Import DXF File	15-10
15.3.	GRID MENU	15-13
15.3.2.	New Grid Like ...	15-15
15.3.3.	Old Grid	15-16
15.3.4.	Save Grid	15-16
15.3.5.	Save Grid As ...	15-16
15.3.6.	Edit	15-17
15.3.6.1.	Edit Grid Parameters	15-17
15.3.6.2.	Edit Contour Attributes	15-17
15.3.6.3.	Edit Contour Levels	15-18
15.3.6.4.	Edit Color Intervals.	15-19
15.3.7.	Add Contours to Map	15-20
15.3.8.	Add Color Regions to Map	15-20
15.3.9.	Add Area to Map	15-20
15.3.10.	Make Grid from Random	15-21
15.3.11.	Make Contours	15-21
15.3.12.	Make Color Regions	15-21
15.3.13.	Set Grid Area	15-22
15.3.14.	Get Grid Area	15-23
15.3.15.	Clear Grid Area	15-23
15.3.16.	Standard ASCII Input/Output	15-23
15.3.17.	Output to DXF File	15-25
15.4.	RANDOM MENU	15-25
15.4.1.	New Random Model	15-26
15.4.2.	Old Random Model	15-27
15.4.3.	Save Random Model	15-28
15.4.4.	Save Random Model As	15-28
15.4.5.	Show Parameters	15-29
15.4.6.	Edit Plot Parameters	15-29
15.4.7.	Add Points to Map	15-30
15.4.8.	Add Labels to Map	15-30
15.4.9.	Add Values to Map	15-31
15.4.10.	Add to Legend	15-31

Table of Contents

15.4.11.	Standard ASCII Input	15-31
15.4.12.	Standard ASCII Output	15-32
15.5.	AREA MENU	15-32
15.5.1.	New Area	15-33
15.5.2.	Digitizing Area	15-33
15.5.3.	Old Area	15-35
15.5.4.	Save Area and Save Area As	15-35
15.5.5.	Add Area to Map	15-35
15.5.6.	Add to Legend	15-36
15.5.7.	Edit Plot Parameters	15-36
15.5.8.	Standard ASCII Input and Output	15-37
15.5.9.	DXF Output	15-38
15.6.	LINE MENU	15-38
15.6.1.	New Line	15-39
15.6.2.	Old Line	15-39
15.6.3.	Save Line and Save Line As	15-40
15.6.4.	Add Line to Map	15-40
15.6.5.	Add to Legend	15-41
15.6.6.	Edit Plot Parameters	15-41
15.6.7.	Standard ASCII Input and/or Output	15-43
15.6.8.	DXF Output	15-44
15.7.	TEXT MENU	15-45
15.7.1.	New Text	15-45
15.7.2.	Old Text	15-47
15.7.3.	Save Text and Save Text As	15-47
15.7.4.	Add Text to Map	15-47
15.7.5.	Edit Text Parameters	15-48
15.7.6.	Standard ASCII Input	15-50
15.7.7.	Standard ASCII Output	15-52

CHAPTER 16 CUSTOMIZATION 16-1

16.1.	INTRODUCTION	16-1
16.2.	CHEMISTRY APPLICATION	16-3
16.3.	HYDROGRAPHS APPLICATION	16-6
16.4.	WELL LOGS	16-6
16.5.	STEP DRAWDOWN APPLICATION	16-8
16.6.	GRAIN SIZE CURVE APPLICATION	16-8
16.7.	PUMPING TEST APPLICATION	16-9
16.8.	CONCENTRATION-DEPTH SERIES	16-10
16.9.	CONCENTRATION-TIME SERIES	16-10

CHAPTER 17	FENCE DIAGRAMS	17-1
17.1.	INTRODUCTION	17-1
17.1.1.	General	17-1
17.1.2.	Application's Content	17-1
17.2.	MODEL MENU	17-4
17.2.1.	Make Panel from Wells	17-6
17.2.2.	Delete Panel	17-6
17.2.3.	Extend Panel	17-7
17.2.4.	Select Working Set (of Panels)	17-7
17.2.5.	Select Working Group (of Panels)	17-8
17.2.6.	Clear Panels	17-9
17.2.7.	Maximum Length	17-9
17.2.8.	Units	17-10
17.2.9.	Coordinate Plane Parameters	17-10
17.2.10.	Viewing Parameters	17-12
17.2.11.	Hand Drawn Lines	17-14
17.2.12.	Filling with Lithologic Patterns	17-15
17.2.13.	Fine Tuning of Points	17-16
17.2.14.	Points	17-17
17.3.	WELLS MENU	17-17
17.3.1.	Select Working Set	17-17
17.3.2.	Select Working Group	17-17
17.4.	MAP MENU	17-18
17.4.1.	Load Map	17-19
17.4.2.	Select Working Set from Map	17-19
17.4.3.	Select Working Group from Map	17-19
17.5.	GRID MENU	17-20
17.6.	DRAWING MENU	17-21
17.6.1.	Make Drawing	17-22
17.6.2.	Drawing Margins	17-22
17.6.3.	Save Drawing As ...	17-23
17.6.4.	Make Legend	17-23
17.6.5.	Write Text to Legend	17-25
17.6.6.	Write Scale to Legend	17-25
17.6.7.	Add Lithology to Legend	17-26
17.6.8.	Print Cross Section	17-28
17.6.9.	To Setup a printer	17-29
17.6.10.	Dimensions of the Cross Section	17-30
17.7.	DRAWING STYLE MENU	17-31
17.7.1.	Draw Lithology Pattern	17-31
17.7.2.	2D Drawing	17-32
17.7.3.	Skip Undefined Polygons	17-32
17.7.4.	Skip Lines Below and Above Log	17-32
17.7.5.	Fill Panel Background	17-32
17.7.6.	Well Column Width	17-33

Table of Contents

CHAPTER 18	USER DEFINED APPLICATIONS	18-1
18.1.	INTRODUCTION	18-1
18.1.1.	General	18-1
18.2.	PREPARING GWW FOR NEW APPLICATION	18-2
18.3.	APPLICATION'S CONTENT	18-6
18.3.1.	Data	18-8
18.3.2.	Units	18-8
18.3.3.	Report	18-8
18.3.4.	Make Random	18-9
18.3.5.	Load Map	18-10
18.3.6.	Help	18-10
18.4.	USING STORED DATA TO CREATE THEMATIC MAPS	18-10

CHAPTER 19	CONCENTRATION-DEPTH SERIES	19-1
19.1.	INTRODUCTION	19-1
19.1.1.	General	19-1
19.1.2.	Application's Content	19-1
19.2.	DATA MENU	19-6
19.3.	TABLES MENU	19-6
19.3.1.	Edit Table	19-6
19.3.2.	Save Data	19-7
19.3.3.	Exit without saving	19-7
19.3.4.	Standard ASCII Input and Output	19-8
19.3.5.	Depth Units	19-9
19.4.	LOG DESIGN MENU	19-9
19.4.1.	New Log Design	19-9
19.4.2.	Attributes	19-11
19.4.3.	Old Log Design	19-12
19.4.4.	Save Log Design and Save Log Design As	19-13
19.4.5.	Edit Log Design	19-13
19.5.	DISPLAY	19-13
19.6.	REPORTS	19-13
19.7.	OPTIONS	19-15
19.8.	MAP	19-16
19.8.1.	Select Working Set from Map	19-16
19.9.	TO SETUP A PRINTER	19-16
	EXAMPLE	19-18

CHAPTER 20	CONCENTRATION-TIME SERIES	20-1
20.1.	INTRODUCTION	20-1
20.1.1.	General	20-1
20.1.2.	Application's Content	20-2
20.2.	DATA MENU	20-6
20.3.	TABLES MENU	20-7
20.3.1.	Edit Table	20-7
20.3.2.	Save Data	20-8
20.3.3.	Exit without saving	20-8
20.3.4.	Standard ASCII Input and Output	20-8
20.4.	LOG DESIGN MENU	20-9
20.4.1.	New Log Design	20-9
20.4.2.	Attributes	20-10
20.4.3.	Old Log Design	20-11
20.4.4.	Save Log Design and Save Log Design As	20-12
20.4.5.	Edit Log Design	20-12
20.5.	DISPLAY	20-12
20.6.	REPORTS	20-14
20.7.	OPTIONS	20-15
20.8.	LOAD MAP	20-15
20.8.1.	Select Working Set from Map	20-16
20.9.	TO SETUP A PRINTER	20-16
20.10.	INTERPOLATION	20-17
	EXAMPLE	20-19

APPENDICES

APPENDIX A	GWV FILES	A-1
APPENDIX B	DATA BASE STRUCTURE FILES	B-1
APPENDIX C	ENTRY & REPORTING FORMS	C-1
APPENDIX D	VARIOUS ASCII FILES .. PROGRAM DEFAULTS & EXAMPLES	D-1
APPENDIX E	LITHOLOGICAL SYMBOLS	E-1

EXAMPLES

EXAMPLE 1	DATA STRUCTURE FILE FOR CHEMISTRY	2-15
EXAMPLE 2	NEW NEW MASTER DATA ENTRY FORM	3-15
EXAMPLE 3	NEW CHEMICAL DATA BASE	7-14
EXAMPLE 4	CREATING A WELL LOG	8-19
EXAMPLE 5	PUMPING TEST	9-21
EXAMPLE 6	HYDROGRAPH	10-15
EXAMPLE 7	STEP DRAWDOWN TEST	11-12
EXAMPLE 8	GRAIN SIZE DISTRIBUTION CURVE	12-9
EXAMPLE 9	NON-LEAKY AQUIFER WELL FUNCTION	13-3

Table of Contents

EXAMPLE 10	LEAKY AQUIFER WELL FUNCTION	13-5
EXAMPLE 11	SCREEN DIAMETER CALCULATION	13-11
EXAMPLE 12	CONCENTRATION-DEPTH SERIES	19-18
EXAMPLE 13	CONCENTRATION-TIME SERIES	20-19



GROUND WATER FOR WINDOWS - PREFACE

Version 1.1, March 1995

Software designed and User Manual and on-line Help written by Jasminko Karanjac, Ph.D. (Civil & Geological Engineering). Software written by Dusan Braticevic, Ph.D. (Mathematics & Computer Graphics).

This manual, including the table of contents and graphics, was produced and printed using the Ventura Publisher desk top publishing software. Screen graphics was captured with the FreezeFrame package.

Information in this manual is subject to change without notice and does not present a commitment on the part of the United Nations or the authors.

The on-line Help and/or Read.me file on the distribution diskette will normally contain updates and revisions to the text contained in this manual.

The order of chapters and topics covered in this manual may appear to be out of sequence. For example, the chapters on additional chemical data processing, such as Chapter 19 - Concentration-Depth Series, and Chapter 20 - Concentration-Time Series could come after Chapter 7 - Chemistry. These applications have been added after the version 1.00 was completed and submitted to the United Nations.

The reader is advised to start with general topics presented in Chapters 2 and 3 (Data Base Structure and Forms, respectively) and read Chapter 5 (common routines). Other chapters may be read when relevant applications are used. Chapter 15 - Mapping is of general importance and contains the information which is used in every application. For comments, ideas, corrections, or problems noticed with this software, please call or fax J. Karanjac, telephone/fax number 404-621-0548. Address: 3194 Hathaway Court, Atlanta, Georgia 30341, U.S.A.

GROUND WATER FOR WINDOWS ... OVERVIEW

Ground Water for Windows is a relational data base and a *Ground Water Information System* (GWIS). The GWW combines the principles of Geographic Information Systems (GIS) with powerful dedicated ground water data processing and reporting modules:



- Master Data
- Chemical Data(including time and depth series)
- Pumping Test Processing and Aquifer Parameters
- Well Logs and Well Construction Data
- Lithologic, Hydrogeologic and Stratigraphic Cross Sections (in two and three dimensions)
- Mapping
- Step Drawdown Test Data
- Water Level Measurement Data
- Grain Size Distribution Curves and Calculations of Hydraulic Conductivity Using Empirical Formulas
- Various Hydrogeological Calculations, such as Well Functions, Drawdowns, and Miscellaneous Well Construction data.
- User-defined storage and retrieval applications.

MAPPING APPLICATION

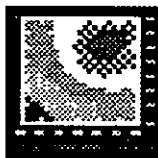

The GWW is capable of:

- Contouring any space-distributed parameter; such as any chemical constituent; interpolated water level or depth to water, transmissivity, hydraulic conductivity or any other hydrogeological parameter; stratigraphic contacts expressed as depth or absolute elevations; thicknesses of lithostratigraphic members; ground surface elevation; etc.
- Adding color regions to the map.

- Creating a gridded equidistant model from random values.
- Digitizing, on screen with a mouse, lines, areas, and points.
- Adding lines, areas, and text to the map.
- Importing AutoCad's .dxf files (data interchange files) and exporting grid models, lines, areas, text, points, and contours to .dxf format.
- Importing ASCII files containing the coordinates of points, lines, areas, grid models, and text.
- Saving various thematic maps as a part of the information system.
- Preparing various ASCII data files for direct input into the modeling software packages.
- Using maps to reduce a large data set to a smaller subset belonging to a free-hand drawn area, a rectangle, or simply selecting wells point by point.
- Using maps to select cross section lines and for selecting wells within a range from the cross section line to be plotted on the lithologic or stratigraphic cross section.

LITHOLOGIC CROSS SECTIONS

You may create lithologic cross sections directly from a map by using a mouse and selecting points one by one, by selecting a hand-drawn area and adding wells within a certain range from the cross section line, or by selecting a polygon area.

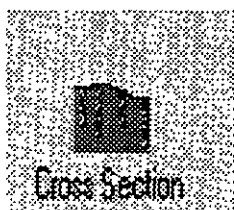

You may add various lines connecting wells:

- ground surface elevation
- static or dynamic water level lines
- lines separating stratigraphic units.

You may label these lines, and select any color, line pattern, font and typeface for drawing or labeling.

- You may create one or more legend blocks and position them at any place on the drawing.

You control the size of the cross section by selecting horizontal and vertical scales. You also define the width of lithologic columns. Symbols displayed on a cross section are the ones selected and/or created by you.

You may also add well construction details, such as casing diameters and position of well screens. Of an appeal in contaminant movement studies will be the option to add one or two graphs representing chemical constituents with depth of sampling.

FENCE DIAGRAMS or THREE DIMENSIONAL MODELING OF LITHOLOGY

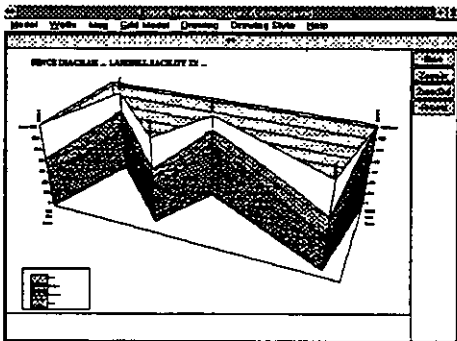

Using this application you may create one or more fence (block) diagrams. The features of this application are:

- Selecting wells for presentation on fence diagrams.
- Connecting layers and litho-stratigraphic units by free-hand drawing or as grid lines created using the Mapping application.
- Filling layers or closed polygons with lithologic symbols and pattern.
- Changing rotation and view angles to enhance a fence diagram.
- Making drawings with legend blocks, labels and headers.
- Saving drawings for printing.

WELL LOG AND WELL CONSTRUCTION

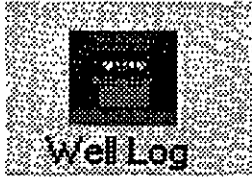

Using the Well Log application on the main menu bar of the GWW software you may do the following:

- Create a new well log by entering drilling data (depths and lithologic description of drilled layers) and construction data (hole and casing diameters, screen positions, materials filling annulus).
- Use the existing lithologic symbols for various lithologic members and/or materials filling the annulus.
- Create new symbols directly on the screen or using a text processor.
- Display a well log with its construction details on the screen.
- Create a lithologic data base which will be used by another application, the Cross Section, for creating lithologic cross sections, and by the Mapping application for creating various random models and contour maps.
- Print a well log, using a default reporting form or your own created forms.
- You may display static water levels on the log.
- You may write descriptions or characterizations of various lithologic members and layers.
- You may enlarge the well construction detail by expanding to other columns. By selecting a large vertical scale, the well log will continue to print on subsequent pages.
- You may design the screen pattern (bridges, holes, or slots) and display or print lines and backgrounds of every symbol in colors.
- You may customize the display and replace English words with equivalents in your native language.

**CHEMICAL DATA
APPLICATION**

With the Chemistry application of GWW you can do the following:

- Create the chemical portion of the Ground Water Information System (GWIS) with unlimited number (except for practical reasons!) of constituents and parameters. You may include any contaminant, trace metal, rare elements, and the like.
- Display on the screen the following diagrams: STIFF, PIPER, WILCOX, and SCHOELLER. Customize the displays, colors, fonts and other attributes. Translate to languages other than English if you need so.
- Add a location map to your reports.
- Input data in ppm or epm units.
- Import chemical data as ASCII files from other data base programs or spreadsheets. Prepare data for contouring, create internal files with random points to be used in the Mapping application for gridding and contouring.
- Report chemical data in tables and graphs.
- Create chemical constituent time series and print as stand-alone graphics.
- Create chemical constituent concentration - depth diagrams and present them either as stand-alone graphics or as histograms superimposed on lithologic cross sections.

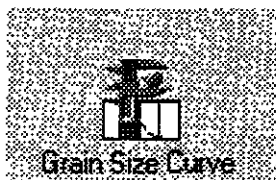
**GRAIN SIZE
DISTRIBUTION
CURVES**

This is one application which might become handy if you have collected plenty of granulometric samples and have them analyzed in a lab. Coupled with another application, MISCELLANEOUS, in which you may calculate hydraulic conductivities based on empirical formulas by Hazen, Kozeny, Terzaghi, Slichter, Zamarin, and the U.S. Bureau of Reclamation, you can produce hydraulic conductivities and transmissivities for layers in boreholes.

You may produce grain size curves as a documentation report, or you may keep them in the data base.

**PUMPING TEST
DATA
APPLICATION**

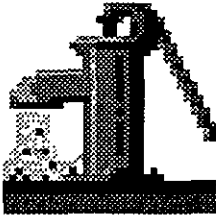

This is a data base and field-data processing package. The following methods and options are featured:

- Confined aquifer tests and corrections for unconfined aquifer conditions.
- Corrections for partial penetration of test well and/or observation well in a confined or unconfined non-leaky aquifer.
- Classical Theis and Hantush methods for non-leaky and leaky aquifers.
- Recovery method.
- Possibility to remove any test data from the fitting procedure.
- Possibility to use test wells which were pumped at various rates during the test.

Some of these solutions appear for the first time in the theory of pumping tests. The computer processing of the variable pumping rates is the new methodology which, to the best of the authors knowledge, has not been implemented before.

For the display of test data or the quality of fit, or for printing results, you may use one of the three methods:

- linear (time) - linear (drawdown) scale
- logarithmic (time) - linear (drawdown) scale
- logarithmic (time) - logarithmic (drawdown) scale

You may report the test results in a graph form or as a table.

WATER LEVEL MEASUREMENTS APPLICATION



You may use this application to keep in the data base all water level measurements for all observation or monitoring wells. The options included in the module are:

- Display of water levels in a selected time period.
- Selection of water levels in absolute elevations or depths to water from a measuring point.
- Display of all points connected by lines, or selection of a "connection criterion" within which the measurements would remain as scattered and not connected points.
- Interpolation of water levels or depths to water at a selected interval. This permits the creation of water level contour maps for a certain date although there may not be measurements on that day.

STEP DRAWDOWN PUMPING TEST APPLICATION



The step drawdown test is conducted to show the efficiency of a well to be used as a production or water supply well. The total drawdown is broken down into two components: aquifer loss (inevitable) and well loss (to be prevented). Two methods of fitting are built in the GWW:

- $S_w = aQ + bQ^2$ (classical Jacob theory)
- $S_w = aQ + bQ^n$ (Rorabaugh theory)

The calculation is demonstrated with a display and a table containing aquifer loss, well loss, and efficiency for each pumping step. The average efficiency for all pumping steps is written into the data base for an eventual comparison and areal analysis.

MISCELLANEOUS CALCULATIONS

In this application you have the following options:

- Well functions for leaky and non-leaky aquifers. You may calculate drawdowns as a function of distance

from a pumped well, time of pumping, hydrogeological characteristics of the aquifer, namely transmissivity and storage coefficients, characteristics of the semiconfining layer if the aquifer is a leaky one, and the pumping rate.

- Empirical formulas by various authors for calculating the hydraulic conductivity on the basis of effective grain sizes (Hazen, U.S.B.R., Kozeny, Terzaghy, Slichter) or the total curve (Zamarin).
- Design of a well considering its diameter, screen characteristics, length of screen, entrance velocity to screen, and the pumping rate. With all but one of these parameters known, the program calculates the remaining unknown parameter. The program also suggests a casing diameter for a corresponding pumping rate if a vertical turbine pump is to be used.

USER APPLICATIONS

You may decide to keep in the data base some information which has not been foreseen by GWW. A good example is inventory of production wells in an irrigation area; or data on rainfall and evaporation. Theoretically you may store just about anything. You assign a name to your "additional" application, prepare entry and reporting forms as for any other application and use most of options available for other applications.

GENERAL CAPABILITIES

The GWW software is independent of printers, plotters, mice devices, digitizing tablets, video display standards, fonts, etc. All this is taken care of by WINDOWS.

The GWW is also language independent. Well, almost! The program and its messages will remain in English, but you may create every reporting form without a single English word.

You may create displays and printouts with 16 million colors, if you need to and have a printer capable of printing them.

You may use any WINDOWS-supported font that you may get hold of, such as TrueType, Adobe fonts, CorelDraw fonts, etc.

You may reduce a large data base to a smaller working set. This is accomplished with a very versatile Selection Condition which permits you to use any piece of information in your data base as a filtering criterion.

You may create even smaller Working Groups to display wells belonging to them on chemical diagrams and lithologic cross sections.

Maps, cross sections, pumping tests, step-drawdown tests, and grain size distribution curves remain in the data base as an integral part of the information system. You do not need to recalculate or reconstruct them if you do not wish to.

This page intentionally left blank.

**1.1.
ACKNOWLEDGMENT**

The *Ground Water for Windows* (GWW in text to follow) software package has been developed by the then United Nations Department for Economic and Social Development; Science, Technology, Energy, Environment and Natural Resources Division; Water Resources Branch, New York. The programming is an outcome of a special service agreement with the programmers of the United Nations Ground Water Software series (UN/GW in the text to follow), now known as the DOS Version of the United Nations Ground Water Software.

The authors of the GWW package are *Dusan Braticevic* (Ph.D. in Mathematics and Computer Sciences) and *Jasminko Karanjac* (Ph.D. in Geological and Civil Engineering). Mr. Braticevic programmed the system, with all its components: data structure, data forms, applications, graphics, etc. Mr. Karanjac designed the system for use by practicing hydrogeologists. He also created the help system and this manual.

The authors wish to acknowledge the role of *Uri Golani*, former Interregional Adviser in the Water Resources Branch of the UN/DESD, for masterminding the whole project, supporting and advising the authors, and providing useful suggestions and hints for improving the whole package. Much credit therefore goes to Mr. Golani for the development and existence of this software.

The author of this manual is indebted to *Laura Peters* and *Jill Raffety* of Golder Associates Inc. (Atlanta) who edited portions of the manual in draft form. He thanks his associate, the principal programmer of the software package Dr. D. Braticevic, for listening to ideas and suggesting some excellent solutions of his own. If the users of this software package find it useful and beneficial in their

work, and like it as much as we the authors do, let them remember our respective spouses, *Obrena Karanjac* and *Jesenka Braticevic*, without whose patience, understanding, encouragement, and compassion we would have given up long ago. We, as authors, dedicate this work to them.

1.2. DISCLAIMER

The former *United Nations Department for Economic and Social Development; Science, Technology, Energy, Environment and Natural Resources Division; Water Resources Branch* and its current successor *Department for Development Support and Management Services* assume no responsibility and shall have no liability, consequential or otherwise, of any kind arising from the use of this program material.

The programmers have used their best knowledge and judgment in making the program, in writing this manual, and in presenting it to the public. The GWW package is in public domain, although the ownership of the United Nations and the effort of the authors should be mentioned whenever the software is used and/or distributed.

Since the GWW package is programmed to run under Microsoft Windows, which provides most of the basic tools used by GWW, sometimes it may be difficult for a novice to differentiate between error messages created by either Windows or GWW. Also it would not be surprising to encounter some problems using GWW, version 1.1, in situations that have not been foreseen by the authors. Furthermore to test the whole system extensively and eventually discover and remove all remaining inconsistencies and/or bugs would take months of work. Rather than that, the authors and the U.N. have decided to present this package and have it tested under the real-world situation.

This does not mean that you should not keep backup copies of data bases created using GWW. Backup the

data base frequently. At some point you will be happy you did!

1.3. **TYPOGRAPHICAL CONVENTIONS**

There are several conventions, whether typographical or symbols, that have special meaning in this manual. The names of menus, and menu and dialogue box options when they refer to actions which you should follow appear in boldface type (e.g. **Map** menu, **Save As ..** menu option).



The hand pointer emphasizes important points. Some paragraphs will be printed as *italics*. These are normally *Notes* or *Comments* with some general hints or suggestions. Names of some data fields will also be printed using italic font style.

Throughout this manual, the term ENTER is equivalent to RETURN. In most cases, this is also equivalent to clicking the mouse on the OK button in dialogue boxes.

The term Cursor refers to the screen cursor that moves when you move the mouse. The shape of this cursor depends on the function selected, and on the action being performed. For details, see a Windows Manual.

The phrase **Select the ...** means you should move the mouse cursor to the middle of the item that you are going to select, and then press the left mouse button once. Alternatively, you may select an item by using the keyboard with the combination of keys, the first of which is ALT and the second is the character underlined on the menu.



There are many examples in this manual. The beginning of each example is marked with the symbol on the left. Each page with an example being worked out is marked with the symbol:



Some of the cliparts used in this manual are taken either directly or modified from Micrografx Designer and CorelDraw.

In this manual we are referring to the GWW as to a system, software package, program, and information system.

1.4. CONTENT OF THE GWW PACKAGE

The GWW package with all its executable files, example ASCII files, and the help files occupies about 11 megabytes (MB) of disk space. A table listing all files that comprise the system is presented in Appendix A.

Filename extensions have special meanings in this package:

- exe** executable file; only GWW.exe is directly executed; all other exe files are called by the GWW.EXE program;
- hlp** help for each major program subdivision;
- unt** file with default units;
- dlt** screen and lithologic symbols ASCII files.

In addition to exe files, there are several files which have special importance:

GWW.000 The template data base, with all default structures and forms (both entry and reporting); this is a blank data base, without data and information, but with all internal files that serve as a starting point in establishing a GWIS. You must not erase this file! You may copy the contents of another database "empty" file to GWW.000 but you must have this file in the GWW directory if you wish to create a new data base.

PPMTOEPM.TBL An ASCII file which contains conversion factors from parts per million (ppm) to equivalent per million (epm).

You may add to this file additional chemical ions which you intend to keep in your data base. It is fully reproduced in Appendix D.

SCREEN.DLT An ASCII file which contains symbols for drawing screen on a well log and painting blank casing. You may modify this file and design symbols other than the default. It is fully reproduced in Appendix E.

ANNULUS.DLT An ASCII file which contains codes, description and symbols for several typical cases of materials filling an annular space (a space between the drilled hole and casing). It is fully reproduced in Appendix E.

LITH.DLT An ASCII file which contains codes, descriptions and symbols for many lithological units. You may add new symbols to this file, change its textual or numerical content, or delete some parts. You may also rename it and read into the program as an ASCII input file in the proper place. It is partially reproduced in Appendix E.

The system may work without some of the executable files. If, for example, the file chem.exe is missing or corrupted, the package will work without the chemical application.

GWV.UNT file is the default units file. The file lists the unit type (e.g., transmissivity), the unit name (e.g., m^2/day), and the unit conversion factor (e.g., 1 m = 100 cm). It is fully reproduced in Appendix D.

1.5. HARDWARE REQUIREMENTS

Ground Water for Windows requires an 80386, 80486, or 80586 (Pentium) personal computer. The software is written for the top-of-line present-day computers. It will run on any computer system which supports Windows, including an 80386 SX with mathematical co-processor, but its efficiency, speed, and overall usability will be greatly improved on fast computers, equipped with plenty of Random Access Memory (RAM), and with a

large hard disk. Your computer system must also contain the following or equivalent:

- Minimum of 4 megabytes of RAM. It is recommended that 8MB or more system memory be installed for increased performance. This is a standard requirement for any large-size contemporary Windows application.
- A hard disk drive with at least 16 megabytes of available hard disk space (after Windows is installed) for the installation of the whole system. Depending on the size of the data base to be created and/or handled, a minimum of 6MB additional disk space should be available for temporary disk space. Do not forget that Windows also needs some storage space for file swapping and keeping temporary information (virtual disk). Also the data base you are going to create may grow to several megabytes size. Each data base is backed up automatically, which requires additional several megabytes storage.
- At least one floppy disk drive to install the package and backup the program and data base files.
- A video adapter, such as standard VGA (640x480), or enhanced or super VGA (800x600 and 1024x768).
- A mouse.
- A printer.

GWW package does not contain video drivers, printer drivers, any other peripheral driver, or fonts. The capabilities of your display, printer, plotter, digitizer and other peripherals, and the fonts available to GWW for display and printout will depend entirely on the capabilities you have installed for Windows. The same goes for languages. For instance, if you install the French version of Windows, you may create an almost 100% French version of a data base.

An almost ideal system configuration for running GWW, at the time this manual is written, would be as follows:

- a 80486 (DX, DX2, or DX4) PC with minimum 8MB of RAM, running at minimum 66MHz, and minimum 256KB cache memory;
- 300MB hard disk;
- one 3.5" high density (1.44MB) floppy disk drive;
- non-interlaced super VGA color monitor, preferably of 17" or greater size;
- 24 bit 2MB graphics accelerator super VGA video card, with 1 or 2MB RAM on-board;
- 2 serial and 1 parallel port;
- a laser printer with minimum resolution 300 dots per inch (DPI), preferably the new generation of 600 DPI laser printers;
- a color printer, such as HP DeskJet 1200C, 550C, or 560C; HP PaintJet XL300; or Seiko Instruments Personal ColorPoint PSE;
- a mouse;
- a digitizing tablet 12" by 12", or a full size digitizer.

Of course, a Pentium machine running at 100MHz and equipped with 32MB RAM, and a 20-inch monitor with an ultra fast video adapter would make the difference!

1.6. SOFTWARE REQUIREMENTS

- Microsoft Windows version 3.1 or higher must be installed prior to running GWW. The current "best" version of Windows, that is Windows for Work Groups version 3.11 (WFWG) is the best choice because it supports 32-bit disk and file access. This, alone, makes the work with large data bases using GWW much more efficient.
- DOS 3.3 or higher. The currently available DOS 6.2 version is definitely the preferred version.

The minimum entries that should appear in your AUTO-EXEC.BAT file are the following:

- C:\WINDOWS\SMARTDRV.EXE
- SET GWW=C:\GWW

While the disk cache driver SMARTDRIVE is optional, the SET GWW line is mandatory, i.e. it must be inserted into your AUTOEXEC.BAT file.

The following values are recommended for the corresponding CONFIG.SYS file:

- FILES=70
- buffers=10

1.7. FEATURES AND LIMITATIONS

You may create large groundwater data bases. There is no apparent limit on the data base size, except for practical reasons. However, although you may create one data base for a whole region, with several thousands of wells making the base, work with such a huge base will be awkward at some point. Searching for particular information may become slow. Ideally the data base should contain less than 2000 well points for retrieval work to be time effective.

You may always merge information using **Write to Standard ASCII File** and its complementary **Read from Standard ASCII File** options.

Almost every piece of information can be written to an ASCII file and read from an ASCII file.

The data base is relational. This is interpreted in the following sense. Each data base is composed of wells, well points, water points, springs, and the like. Each well or a water point is an entity defined with its X and Y coordinates and a unique identification. The well identification can be a number, a string of characters, or any combination of numbers and characters. Each well point (well, spring, etc.) comprises various data and information

each of which is uniquely identified. Each data entry form must start with the *Well Identification* field. This field entry is used to relate information input from different applications. For example, if you create a master data file, assigning the identification number to a well '55', and then type the information for well 55 in a hydrograph entry form, that information can automatically be associated with all entries made for well number 55.

- The data base is object-oriented. By definition, an object is something you place on an entry or reporting form. Objects can be fields or tables containing values, graphics, text, or shapes that affect the appearance of the form (*ObjectVision 2, reference Guide, Borland International, Inc. 1991*). For example, the calcium content of a water sample is an object. This information is typed in its own data field, which is characterized by label font and font style (e.g., Times font, 12 points, bold), by data font (the way in which numerical values for calcium will be displayed and/or printed), background color for the field, label and/or data alignment (vertically and horizontally), etc:

Since a piece of information is an object, you may also design output or report forms and place and arrange objects according to your specifications. This means that you can take any information from any part of the data base and place it on the screen or a report form in almost any way you wish.

You may create various thematic maps which, when saved, become an integral part of the data base. Ideally you may create a base map for your project, country or the whole region. You may fill this base map with information such as location of all drilled wells - one map with the location of all wells for which the driller's log and lithological characterization are available - another map with the location of all wells with water samples - still another map, and so on. You may create many such maps and retrieve them when you wish to see at a glance the amount of particular information available in your data base. A water level contour map for a certain date is also one of the maps available in the data base. Once set

up, it may be retrieved in almost an instant, without recalculation.

GWW includes almost all the features of a sophisticated contouring program such as:

- creating a regularly spaced grid from irregularly spaced data;
- selecting any portion of the map to do the gridding and contouring;
- contouring, using a gridded model, and creating contour maps for any parameter distributed in the X-Y space;
- contour line editing, that is selecting labeled and auxiliary contour lines, colors, color intervals, line thicknesses and patterns, fonts for labels, and many more;
- adding text, lines and areas to maps; and
- screen digitizing of lines and areas, and saving them in standard ASCII files.

As a special bonus you may use the mapping application of the GWW to prepare data files as input to mathematical models, such as the MODFLOW.

GWW creates not only a ground water data base, but a *Ground Water Information System (GWIS)*. It combines classical ground water information with digitally mapped geographic displays. Entire maps can be imported to the data base in a standard dxf (data exchange file) format.

Graphics programs require a lot of memory. If you have a slow machine with little available RAM, or if you are using an earlier version of Windows, GWW can be very slow or you may run into other problems. For example, GWW might become incapable of certain operations, such as printing. It is recommended to use GWW alone; all other applications should be closed before running GWW.



NOTE. Remember that a fully developed GWIS, with about 1000 wells, 20 maps and 10 cross sections fully colored, named as objects and stored in GWIS, may easily become 3MB big.

1.8. PRE-INSTALLATION

Before you perform any installation procedures you should backup the original GWW program floppy disks and use the backup copies for installation. This can be done using the Windows File Manager **Copy Disk** option. Note, however, that when you copy a floppy disk, both disks (source and destination) must have the same storage capacity. In the case of GWW, you should be using high density 3.5-in floppy disks. The procedure to copy floppy disks from Windows is the following:

1. In the Main group, choose **File Manager** icon.
2. Insert the source disk in the drive you want to copy from.
3. From the Disk menu, choose **Copy Disk**.
4. Answer the prompts in the dialogue box (if you have two floppy drives). Select the letter of the source drive and the destination drive, and then choose the **OK** button. (If your computer has only one floppy disk drive, this dialogue box does not appear.) The screen may look as in Figure 1-1.
5. A confirmation dialogue box appears, in which you can verify that you want to copy the disk.



Be careful! When you copy an entire disk, there is no way to recover information previously stored on the destination disk.

If you have only one floppy disk drive, follow the instructions to switch source and destination disks as needed.

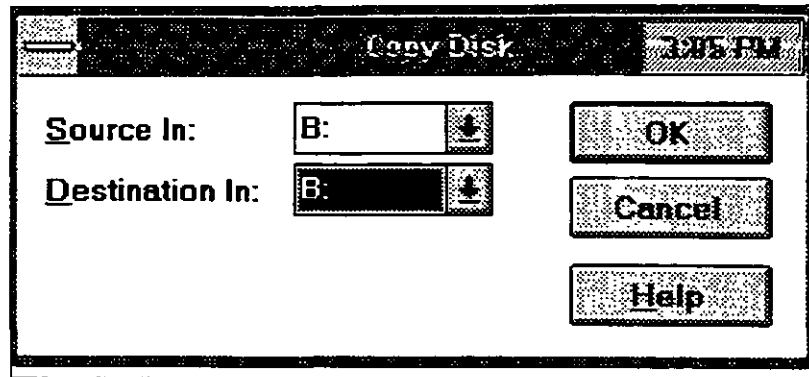

Figure 1-1

1.9. INSTALLATION

The installation is from one of disk drives using the DOS prompt. Before you start the installation read the file `Readme.1st`. This file will contain additional information after this manual was written. The installation procedure may be different, depending on the version of the program. The GWW software package comes on 4 diskettes, which are 3.5-in. size, double sided and high density (1.4 MB).

1. Insert GWW disk number one in the appropriate floppy disk drive.
2. Log (change drive to A: or B:) to the floppy disk drive from which you wish to install GWW.
3. From the DOS command line type `InstallA` or `InstallB`, depending on which disk drive you are using for the installation, and follow the prompts.

Disk One contains an installation batch file, `INSTALLA.BAT` or `INSTALLB.BAT`. All files come in compressed form, or archived. The installation routine will decompress the files. Disk one contains also a decom-

pressing file, ARJ.EXE. Its use is prohibited for commercial purposes. This file will be copied to the directory C:\GWW, which will be created by the INSTALLA.BAT or INSTALLB.BAT file on disk one. You should place disk two, disk three and disk four in one of floppy disk drives and repeat the command INSTALLA or INSTALLB. All files on all four diskettes will be decompressed and copied to the directory C:\GWW. The order of disk decompressing and installation is not important, except that disk no. 1 must come first because it contains the decompressing file.



NOTE. To install GWW alone you need about 14 MB disk space!

1.10. STARTING THE PROGRAM

You are advised to keep your data base files separate from the GWW directory. The GWW directory is already very big. You will notice that you will quickly create many ASCII data files, either as a backup, or as inputs to the data base. Likewise, you will have different forms, .dxf files, etc.

1. You should make a new directory giving it most probably the name of your project, region, or country.
2. You should ensure that your AUTOEXEC.BAT file contains the line SET GWW=C:\GWW (see also 1.6). (You may have another drive letter, not necessarily C. However, if your installation program copied the files to the C: drive you should move all files to another drive on which you should create the directory \GWW.)
3. If you do not have a separate GWW group on your Windows menu, and you want to have it, you may create it in the following way.

- 3.1. From the File menu in the Program Manager's group, choose **New**. The New Program Object dialogue box will appear.
- 3.2. Select the **Program Group** option, and then choose **OK**. The Program Group Properties dialogue box will appear.
- 3.3. In the description box, type *Ground Water for Windows*. This description will appear in the title bar of the group window and below the group icon.
- 3.4. Choose **OK**.
4. You should create the program item which will represent the GWW application. You may do it in several ways. The procedure by using Program Manager is explained below.
 - 4.1. Open the GWW group. (Click on the title bar with the words 'Ground Water for Windows.')
 - 4.2. From the File menu in Program Manager, choose **New**. The New Program Object dialogue box will appear.
 - 4.3. Select the Program Item option, and then choose **OK**. The Program Item Properties dialogue box will appear.
 - 4.4. In the Description box, type a description that uniquely identifies the GWW application such as Ground Water for Windows. This description will become the label that appears under the icon in the group window.
 - 4.5. In the Command Line box, type the name of the program file. In our case this will be: C:\GWW\GWW.EXE. Here you may add the name of the data base in continuation, for instance, C:\GWW\GWW.EXE EGYPT.GWW. In this case, the data base EGYPT.GWW will open automatically when you click on the GWW Main icon. For beginners, we do not recommend this procedure. If you type C:\GWW\GWW.EXE but without any data base name, you will be given an opportunity to select a new data base or work with one of existing data bases. When you gain experience and become com-

portable with the GWW software, you can switch to automatic opening your data base.

- 4.6. In the Working Directory box, type the name of the directory where the program files (data base file) for the GWW application are located and where new files will be placed. The directory you specify here will become the current directory while the application is running. In Figure 1-2, you will notice that a directory EGYPT has been created to accept all files that may be created when running the GWW software.

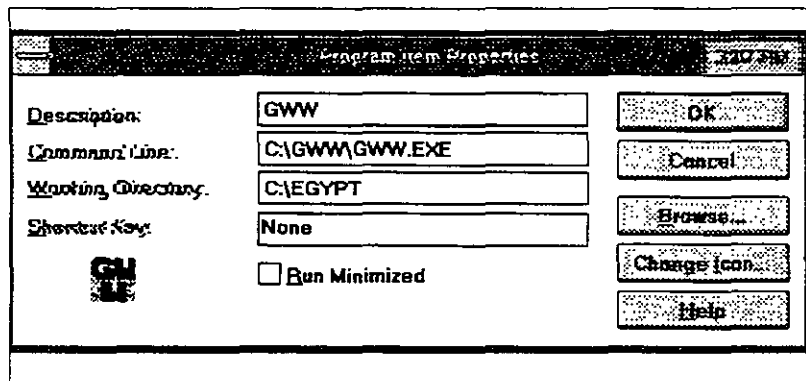

Figure 1-2



The working directory should have already been created in step 1.

- 4.7. Choose **OK**. The dialogue box will close, and the new program item will appear in the group.
5. Icon that represents the Ground Water for Windows application, or GWW program-item icon is as shown in Figure 1-3.

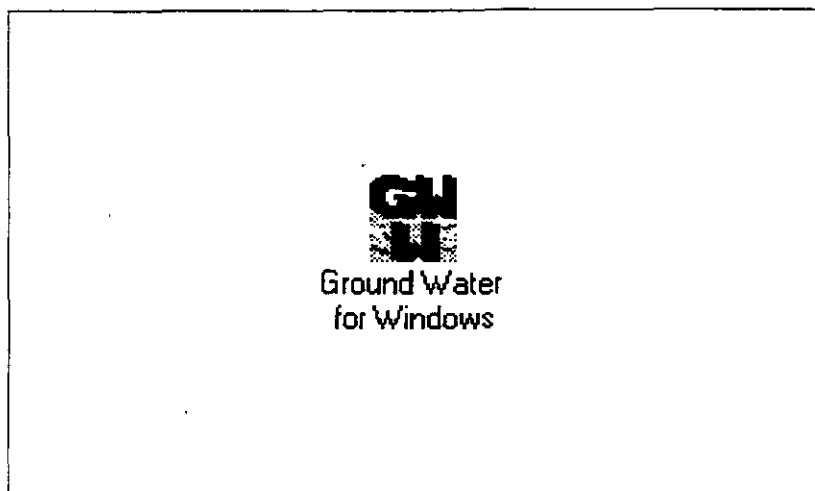

Figure 1-3

1.11. HELP

There is an extensive on-line help in GWW. Every major module has its own on-line help system. Thus, in a sense, the help is context-sensitive. To find information in Help, choose **C**ontents from the Help menu. To search for specific information, choose the **S**earch button in the Help window. The Help part of the software has been written using .RTF (rich text format) files, together with the Windows Help Compiler, which turns the .RTF files into a hypertext Help file, complete with contents page, hypertext links, and pop-up definitions.

You can add your own comments and notes to a Help topic and view this information later. However, the general operation of the Windows user interface is described in your Windows documentation and will not be repeated either in this manual or in the on-line Help. Your Windows documentation describes the general principles, conventions and instructions of the interface such as operation of the pull down menus, selection of file names, operation of dialogue boxes, etc. Some of Windows basics will be repeated in the following section.

1.12. WINDOWS BASICS

1. The Parts of a Window

This section describes the elements of a window. Each window contains the following elements (as shown in Figure 1-4):

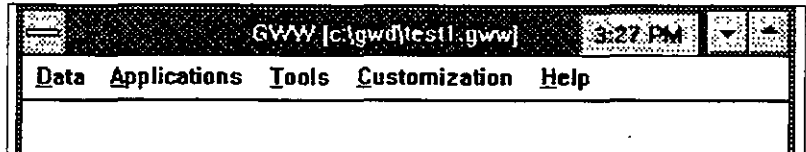

Figure 1-4

- Window borders are the four edges that define the border of a window.
- The title bar is the area directly below the window's top border. The title bar shows the name of the application, GWW, and the name of your open data base.
- The control-menu box, in the upper left corner of the window, lets you move and size the window, close the window, or switch to another application.

The menu bar contains GWW's menu names, such as **Data**, **Applications**, **Tools**, **Customization**, and **Help** in the example shown in Figure 1-4. When you click a menu name, a list of that menu's commands is displayed. Each application has different menus and menu commands. You may click a menu name, or use the keyboard pressing first the ALT key followed by the case-sensitive underlined character.

The mouse pointer (cursor) indicates where the mouse cursor is currently positioned on the screen.

Maximize and *minimize* are sizing buttons. They are located in the upper right corner of the window and are used to maximize or minimize the window. The Maximize button enlarges the window to fill the entire screen, and the Minimize button reduces the window to an icon.

If the window is maximized, the Restore button replaces the Maximize button. Restore restores the window to its previous size and position.

In most of the GWW windows/screens you will be able to size and resize the window. A good practice is to maximize the initial window displaying the main menu (Data, Applications, Tools, ..., Help). In some GWW graphics applications, you will be able to fit to window, that is to fill the whole window with the graphics. In other applications, you will be able to use the command *Display Full Form*, which is opposite to the command *Normal Display*. Display full form command works as View page command in most other graphics programs (CorelDraw, Designer, etc.).

2. Working with Icons

Icons are visual representations of minimized windows, applications, or documents.

To work with an icon, you expand it. Double-clicking on the icon will cause the icon to become a window in which you may work.

One of options to start the GWW program is from the DOS command line typing the following command:
WIN C:\GWW\GWW.EXE C:\GWD\DEMO.GWW.
This command is interpreted in the following way:

- (a) Start Windows (Win portion).
- (b) Activate the GWW program (C:\GWW\GWW.EXE portion).
- (c) Open the data base DEMO.GWW located in the directory C:\GWD.

As a shortcut, you may create a batch file, say GWW.bat, with the above line as the only line in it. By simply typing GWW you will initiate the program, both Windows and the GWW application.

Another option is to create GWW group, GWW program item, as explained in section 1.10. In the GWW group there will be the main GWW icon which is the executable icon for starting the GWW program.

To activate the GWW program, you should double-click on the GWW icon. With the keyboard, use the arrow keys to select this icon, and then press ENTER.

3. Working with Menus

Immediately below an application window's title bar is a menu bar. The menu bar lists the names of one or more menus. For example, in Windows, the Program Manager menu bar contains the File, Options, Window, and Help menus. The menu bar for the mapping application in GWW contains the following menus on the menu bar: **Map**, **Grid**, **Random**, **Area**, **Line**, **Text**, and **Help** (see Figure 1-5). Additionally, the Random menu is also open:

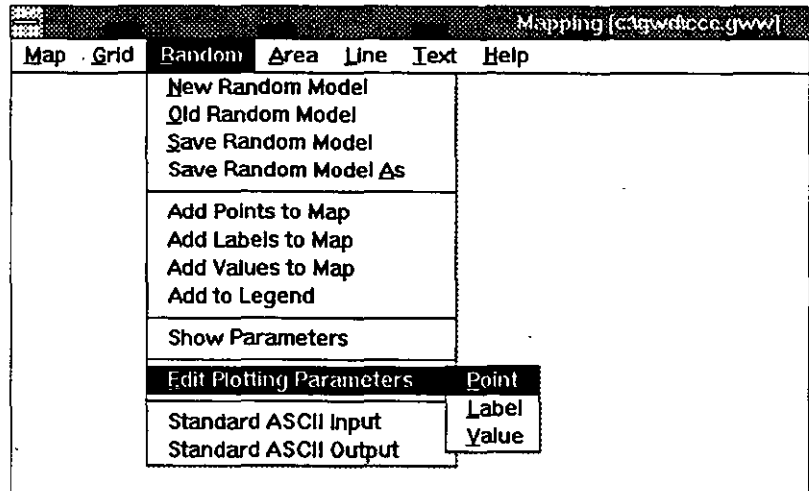

Figure 1-5

To open a menu, follow these steps:

- (a) Click on the menu name, if you are using a mouse.
- (b) If you are not using a mouse, press Alt+X, where X is the key that represents the desired menu name. This

is the key which is equivalent to the underlined character on the menu.

To close a menu without selecting a command, click on a location outside of the menu, or press the Esc key.

In some windows in GWW, such as creating and editing an entry data form, or a reporting form, you may want to modify some of the attributes of a data field. For instance, you want to change the label or data font. If you click inside a larger frame which contains several fields, the whole frame will be selected. This is not what you want. You need to click outside the frame, and then move the mouse pointer inside the data field you wish to modify. Click again and this field will become the object you work with.

4. Working with Dialogue Boxes.

A dialogue box is a window that frequently provides information and always requests a user response. Figure 1-6 shows a sample dialogue box for editing contours in GWW. Dialogue boxes use drop-down lists when there is not enough room for a list box. This is marked with a

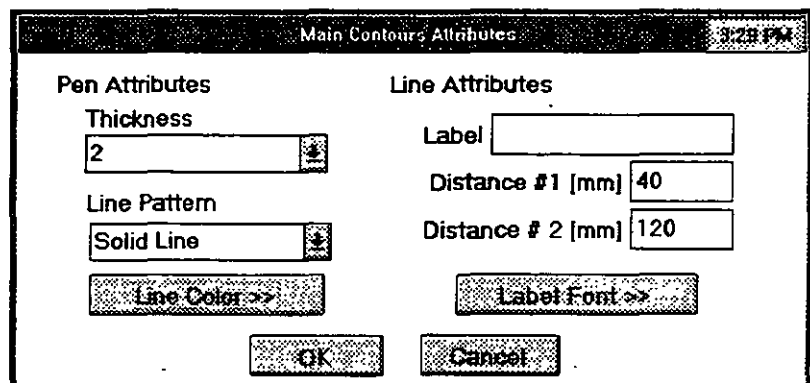

Figure 1-6

single or double arrow indicating that there is more to come. For instance, clicking on 'Label Font' will open another dialogue box, or a drop-down list, with all fonts currently available to select from.

5. Scrolling for Information

When an application contains more information than can fit in a window, vertical and horizontal scroll bars appear along the window's right and bottom edges, as shown in Figure 1-7. Within the scroll bars, a scroll box moves to reflect your relative position within the docu-

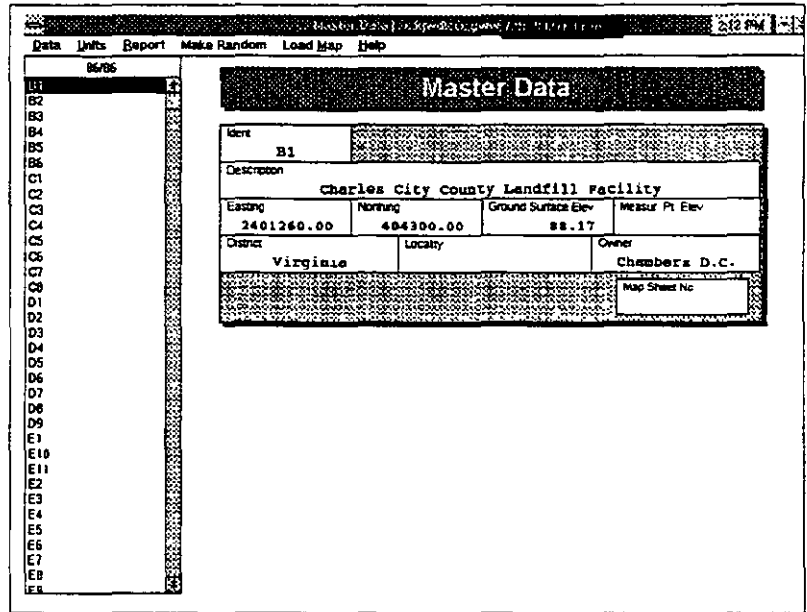

Figure 1-7

ment. In the data base shown in Figure 1-7, there are 86 wells. The window cannot display all wells, and the vertical scroll bar serves to help you display more information.

To move a short distance, click on the up and down or left and right arrows at each end of the scroll bar. To move up by approximately one screen, click on the vertical scroll bar above the scroll box. To move down by approximately one screen, click on the vertical scroll bar below the scroll box.

1.13. Warnings

It is relatively easy to open the same data base more than once. If you reduce an application to an icon (by selecting the minimize arrow button) or temporarily "loose" the GWW screen by clicking outside it and by returning to the Program Manager's window, you may be tempted to start the GWW program again by clicking on its icon. You may open another data base and have two bases concurrently running, one in background and another as an active application. However, if you decide to start the same data base which has not been closed, the GWW will display the error message as shown in Figure 1.8.

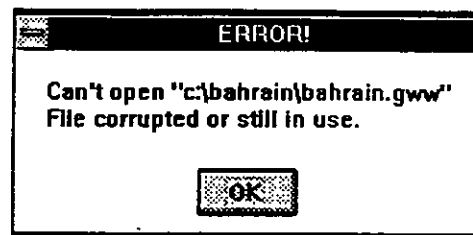

Figure 1-8

This will be a warning that you have not closed the previous data base.

If, at any moment you do not see the GWW window, either its main or an application's window, remember to invoke the Windows Task List. Task List is a window that displays a list of all the applications you are currently running. You can use Task List to switch to another application.

You have two ways to display Task List. The first way is to use the mouse and double-click on the desktop (that is, not inside an open window). The second way is to use keyboard and press CTRL+ESC key combination.

Once in Task List, double-click the name of the application you want to switch to. The case with Chemistry application running in background is shown in Figure 1.9.

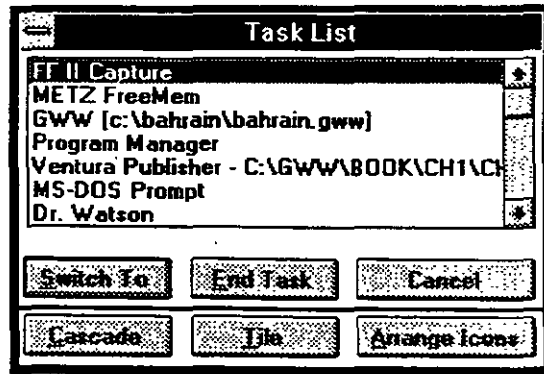

Figure 1-9

Try also not to close a GWW application by clicking on the Control menu box (a small diskette symbol in the upper left corner of each window). Although it is intended to be used for switching to other applications, try to use the GWW way of closing an application, that is, use the Exit command which is normally located at the bottom of the leftmost menu option.

If the Exit command in a GWW application does not close the application, use the combination ALT+F4 keys as shown in Figure 1-10.

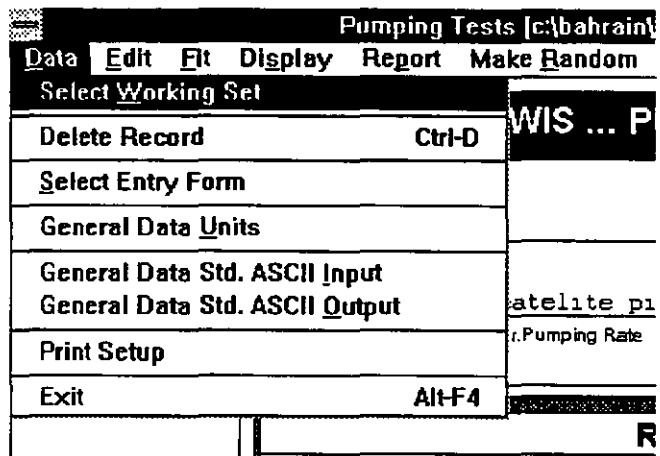

Figure 1-10

This page intentionally left blank.

**2.1. BASIC
CONCEPTS OF
GWW DATA AND
FORMS STRUCTURE****2.1.1. Objects In
GWW**

The GWW data base is built of objects. For the definition of an object see Chapter 1, Section 1.7.

In GWW, each data field is an object. Thanks to this, you can create your own entry and reporting forms, you can assign to the content of each field the label, label font, label color, field border, and field background color. You may fill the field with data and assign to the data the same kind of attributes such as font, color, and text alignment, both horizontal and vertical.

Each line, area, lithologic cross section, and map is an object. Lines, areas, grids, gridded models, well logs, chemical data, water level data, measurements during a pumping tests, and many more can be saved in an ASCII data file, with all, some or no attributes.

**2.1.2. Foreign
Languages**

You may use different languages in designing your entry and reporting forms. Most of the program-built messages on the screen will be in English, but you will work more comfortably using your own language in entry forms and creating reports in your language. For all pre-designed forms, such as chemical retrieval diagrams (STIFF, Piper, etc.) or well logs, you have an opportunity to replace the defaults with your own text. In the pre-release beta tests, data bases have been created with fonts in Arabic, Hindi, Nepalese, and Cyrillic, in addition to English and Spanish.

- 2.1.3. GWW Forms** GWW uses forms to gather (input or entry forms), display, calculate, edit, and print (reporting forms) information. Several forms can be stacked into a GWW application. You may select one of the available forms, either a default form pre-programmed by the GWW programmer, or a form created by you. In Chapter Three you will learn how to create such forms. GWW form outlines are saved separately from the values they display.

To optimize disk space and to be able to share values with other applications, values are stored in data base tables or in exported ASCII files.

In most cases, forms can be either entry or reporting forms. Some reporting forms can apply to a single analysis, such as to one STIFF diagram (in the Chemistry application) with associated parameters defining one single sample. They may also report information from more than one sample, such as Piper Diagram, Wilcox, and Schoeller diagrams in the Chemistry application.

**Program-supplied
Default Forms**

GWW supplies an entry form in each application only when you make a change in the data structure. That is if you add a new data field or edit an existing one and use the button OK to save the change, GWW will interpret this as a change which requires a new entry form. The program-supplied entry form will list all data fields that currently make the data structure for an application.

Standard Forms

Standard Forms are the forms selected by you to be standard for a particular data base. The program comes with standard (default) forms for each category of entry and reporting. You may override the defaults and create your own standard forms, associated with the data base of which they become a part. After creating a form, you should save it using internal data base name 'Standard'. You may also save the form as an ASCII file on the disk and edit it later if you wish so.

Entry Forms

Entry Forms can be either standard (default), which are built into the program, or created by you as explained above. Entry Forms can be custom created; you can add some parameters, use language other than English,

change label fonts, colors, or alignments, and many more. You may have more than one entry form for each major application group.

Reporting Forms

Reporting Forms can also be standard (default), one for each category of reporting, either taken as the forms that are supplied with the package or modified to customize the need of a project. Reporting Forms can also be created under different names for different reporting needs. Nonstandard forms are used to report mixed graphics, say a well log and a chemical diagram on the same reporting form. Nonstandard forms are created using a special option on the Reporting Forms Editor.

2.1.4. **Relational Data Base**

The GWW data base is a relational data base. "Relational" in this context implies that the application will find all information needed no matter where it is input or stored. In this way any information is typed only once. For example, X and Y coordinates are required in most applications, but normally you will type this information only in **Master Data Entry Form**. Or, if you import a hydrograph data file or a lithological data file created by the version one of the United Nations software (GW5 or GW6 modules), which is a non-Windows application, X and Y coordinates and ground surface elevations will automatically become a part of the master data base.

2.1.5. **Data Base**

Data Base is a general term which applies to the collection of program forms, both entry and reporting, including default and user-created; data; maps; and drawings. The name of the data base currently in use is displayed in the title line. The maps either imported as .dxf files or created by you are also an integral part of the data base (unless you forget to save them!). Internal files, which control the data file structure, forms, tables, etc., are also a part of the data base. ASCII files are not a part of the data base.

2.1.6. **File**

A file can be a data file, either ASCII or binary, or an internal file. GWW internal files are created by the program or by the user. **These are not DOS files** but they are integral parts of the GWW data base. You can create,

edit, save, or delete most of them. For example, you may create and edit various text that will enhance a map. You may save this text object as an internal file, assigning to this a name. However, unless you save this text as an ASCII output file you may not view or edit the text outside the GWW program. You may edit this text inside the GWW program provided you have associated a name with the text.

2.1.7. Fields

Data, Text and Drawings fields are three types of fields that make a reporting form. A form is equivalent to a page. E.g., a STIFF diagram reporting form may contain a frame with the STIFF diagram, some text field identifying the project, plus data fields with constituents in mg/l or epn, or both. There may be another drawing on the same page (form) with a map showing location of the sampling point.

2.1.8. Field Types

There are two types of fields on entry forms in the GWW system:

- text
- data

There are four types of fields on reporting forms in the GWW system:

- text
- data
- drawing
- column (for reporting on more than one well)

2.1.9. Text Field

This is a constant-content field with some predefined textual content. This text will always be displayed whenever the form, whether entry or reporting, is selected. This field is used for headings, textual comments, explanations and the like. A special form of a text field is the Header. It has some default values which are selected when the field is created using the Form Editor.

2.1.10. Text Field Attributes

Text Field attributes are:

- Field Name
- Border
- Background
- Field Label (text typed in the field)
- Label Font
- Label Color
- Label Alignment

2.1.11. Data Field

Data Field contains numerical or textual (character) data. An entry in a data field must conform to one of these data types:

- well identification (a unique data type which is used to relate various parts of the data base to the same well or sample);
- character (alphanumeric string);
- integer;
- floating point number, dimensioned;
- floating point number, nondimensioned;
- date; and
- time.

When a data field is identified as containing information which is a real number, and the type of data is selected as 'dimensioned,' the user will be prompted to associate one of the available units with this data field.

2.1.12. Data Field Attributes

Data Field has all the properties (attributes) of a text field plus attributes for data:

- Data Font
- Data Color

- Data Alignment (vertical and horizontal)

2.1.13. Drawing Field

Drawing Field contains a drawing. Since a "Drawing" field may have a title or a text, this field has the same attributes as a text field. Only report forms may contain a drawing field. A reporting form may contain more than one drawing field. An individual water sample can be presented as a STIFF diagram, with its location on another drawing which could be a location map. Both maps, plus much of other textual or numeric information can be reported on the same page.

2.1.14. Column Field

Column Field is a column. Several columns make a table. Only report forms may contain a column field. Label attributes are actually attributes for a table header.

2.1.15. Field Name

Field name is a text string which uniquely identifies an entry field. It is important when creating a reporting form to use the exact text string that had been defined in data structure and in entry forms. For example, if in the chemistry entry form the field that will input the alkalinity values of a water sample is typed as Alkalinity, the Field Name in the reporting form must be typed exactly the same (case-sensitive, number of characters or blank spaces, etc.). Nothing will happen if you mistype one or more field names in a reporting form. These fields will remain blank in the report since the program will find nothing to associate the fields with.



NOTE. Do not forget the special role of data field names: these must be uniquely defined, case-sensitive typed as declared in entry/reporting forms. This is the only way that the program will know what to type and where. Form Editor will automatically write these names. You should not try to modify them.

Some field names are protected! The protection implies that you should not try to modify these field names. If you do, GWW will not be able to use them in some calculations, drawings, or for creating graphics. The protected field names are: X,



Y, Z, ZM in master data structure, all major cations and anions in chemical data structure, the entries Cations, Anions, SAR, EPM in chemical data structure, most of pumping test field names in pumping test data structure, SWL in well log data structure, all step-drawdown field names in step-drawdown data structure, and all field names in hydrographs data structure. You may add new fields with their own field names, but do not attempt to change the existing field names if you suspect that GWW may need them for a calculation or graphical display.

2.1.16. Border

Border includes the solid frame around a field and the shadowing of the field, both defined by you. Borders can be thin or thick, as specified by you; they may include full frame or just one of the four lines (left, right, top, bottom). Shadowing can be thinner (numbers 1 or 2) or thicker (numbers 3 and 4). You may type a text or an information without any line defining its frame. Set **Frame** in **Border** attribute to **None**.

2.1.17. Background

Background refers to the color selected by you to paint a field. The whole color palette provided by Windows is available. Each field can be painted.

2.1.18. Field Label

Field label refers to the text typed to identify a field. Here is the possibility to use languages other than English. Although a field may be identified with Field Name, say Conductivity, which should not be changed if you wish GWW to use it to produce a Wilcox diagram, e.g., the field label may be typed in Spanish as Conductividad. Unless you change it, the field label will be identical to the Field Name selected in creating a form.

2.1.19. Label Font

You select a Label font. Whatever comes with Windows can be used. The selection is standard as explained in the Windows manual; you select the font, the size (points), and style such as bold, normal or italic. You may download additional fonts, which are not provided by Windows. One of fonts could be Cyrillic, with which you may create your groundwater data bases in Russian, Bulgarian, or Serbian. You may use an Arabic font to create data bases in Arabic (hopefully, by correctly assuming

the direction of writing words). Today you have a myriad of font offerings.

2.1.20. Label Color

You may also select Label color. Each and every label can be colored differently. You may select the color by sliding the three slides (R for red, G for green, B for blue) in the appropriate dialog box, or by directly selecting a color from the palette.

2.1.21. Label Alignment

Label Alignment is used to align the label either as left or right aligned or centered. The label can be placed on top, center or bottom of the field. This is called horizontal or vertical alignment, respectively. You may also use various offset options.

2.2. DATA BASE STRUCTURE

2.2.1. Data Base Structure Concept

Prior to starting to work with a groundwater data base using GWW, you must create a data base structure for your new data base. The term structure in this context means the following:

- (a) a unique definition (name, title) for each data item;
- (b) the length of each data field (number of characters or numerals);
- (c) data type;
- (d) if data type is a dimensioned numerical, such as the ground surface elevation Z , there is a distinction between numerals with fixed or floating point; if it is with fixed points, then you must assign the number of digits after the point; and
- (e) unit selection for the data.

The default data structures are built into the data base template, GWW.000. When you start a new data base this file will provide all necessary structures, same as standard data entry and reporting forms. You will have a chance to modify these to better suit your requirements. You will learn to do it in Example 1.



NOTE. Your first step in creating a new data base will be to modify the default data structure for one or more applications. For example, GWW does not know which stratigraphic units you wish to define and that you wish to keep in the data base the elevations of their tops or bottoms. If you do not enter elevation data on positions of stratigraphic units you cannot create contour maps for such data, nor you can draw stratigraphic lines of lithostratigraphic cross sections.

One example is provided in the following table for the Master Data Structure file. All file structures are reproduced in Appendix A.

Field Name	Field Length	Field Type	Format	No.dec.digits	Unit symbol
Well Ident	10	Well			
Description	50	Char			
District	15	Char			
Locality	15	Char			
Owner	15	Char			
X	10	Num(Dim)	Fixed	2	m
Y	10	Num(Dim)	Fixed	2	m
Z	10	Num(Dim)	Fixed	2	m
Zm	10	Num(Dim)	Fixed	2	m
Map Sheet No.	10	Char			

In simple terms, the data base structure is the list of data entries that you wish to have in your data base. You can create these lists independently for each of the following applications:

- Master data
- Chemistry - samples
- Chemistry: concentration-depth series
- Chemistry: concentration-time series

- Pumping tests
- Hydrographs
- Lithology/well logs
- Step drawdown tests
- Grain size distribution curves, and
- User-defined applications.

Normally, you should observe the following:

- (1) Each application structure must start with the well identification. This item uniquely defines a well or a sample. The information related to this well or sample will be linked to any application which needs to use it (display or report).
- (2) You must not repeat information which is already contained elsewhere in an application. E.g., if X and Y coordinates are a part of the Master data structure, they must not be selected in any other application: chemistry, hydrographs, well logs, pumping tests, grain size curves, and/or step drawdown tests. They may appear on the entry form for well logs, but when you type the well identification of a well which was already input using one of the Master entry forms, this information will be automatically copied from the data base into your well log entry form. However, be careful: the information will be copied only if the field name on both forms is absolutely identical, including its case. For instance, this means that you cannot expect the program to find the information for the X coordinate if this entry is defined as X in the Master data entry file, and as Easting in the Chemistry data entry file. Of course, this applies to the field names and not to field labels.

This will become more clear when we work with some examples.

2.2.2. Data Base Content

The data base structure you select for your new data base becomes its integral part. All changes, editions, modifications, and assigning new internal file names to various data structure files will apply only to your currently open data base. In other words, all the changes that you

make while working in a data base will be saved only in that data base, not in the template GWW.000.



NOTE. You may, of course, make your changes in a data base to which you assign another name, and then copy your data base into GWW.000. In this way, next time you wish to create a new data base your own version of the template will be read as the standard! This may be one of your first steps in creating a template GWW.000 as a country or project specific default. You may also add some basic maps to your base template.

Also you may save your data base structure for each application as an ASCII file, and use it for another data base to override the default.

All data base default file structures which are prepared for you as a default are listed in Appendix B. The Master data file structure is already displayed above.

2.3. EXAMPLE OF CREATING A NEW DATA FILE STRUCTURE

2.3.1. Getting Started

If you have created the GWW group and GWW program item properties, as suggested in Chapter 1, Section 1.10., you may start the GWW program by double clicking on the GWW icon. The initial screen as shown in Figure 2-1 will appear displaying the United Nations logo and the menu bar with Data, Application, Tools, Customization, and Help menus. Normally, when you start GWW for the first time you will notice the title GWW[;] in the title bar. This reminds you that you have not yet opened a data base. (In a repeated work, the last opened data base

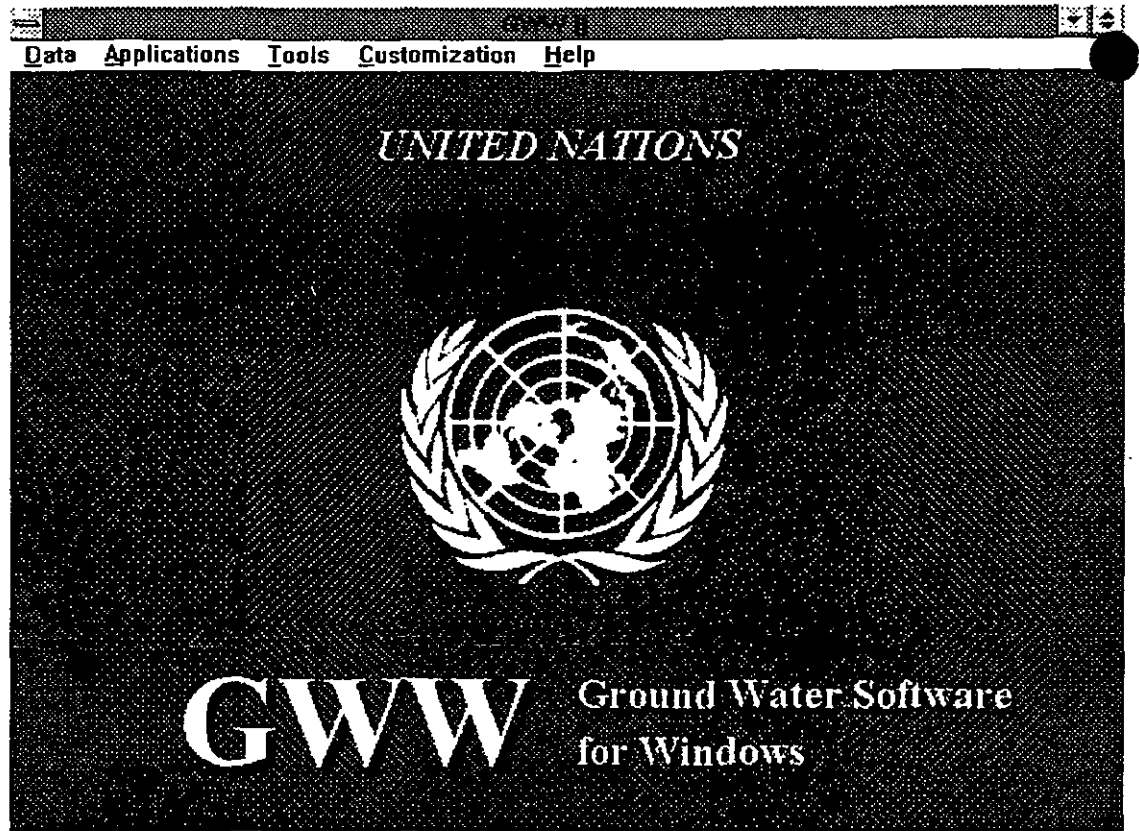

Figure 2-1

will be automatically selected.) The information on what you worked with the last time you opened GWW is saved in the file GWW.INI which is located in the C:\WINDOWS directory.

To start the creation of a data base you must select DATA from the main menu, followed by New Data Base.

1. Select Data from the menu bar. The display is as shown in Figure 2-2.
2. Select **New GWW Data Base** to create a new data base. The dialogue box as shown in Figure 2-3 will then be displayed.
3. Type the new name for your data base. Type Example.gww. Use the extension .gww for your convenience. GWW offers you a list of available files with extension .gww.

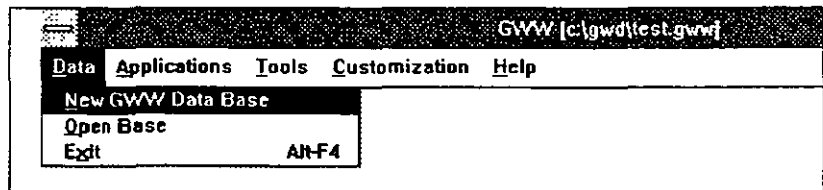

Figure 2-2

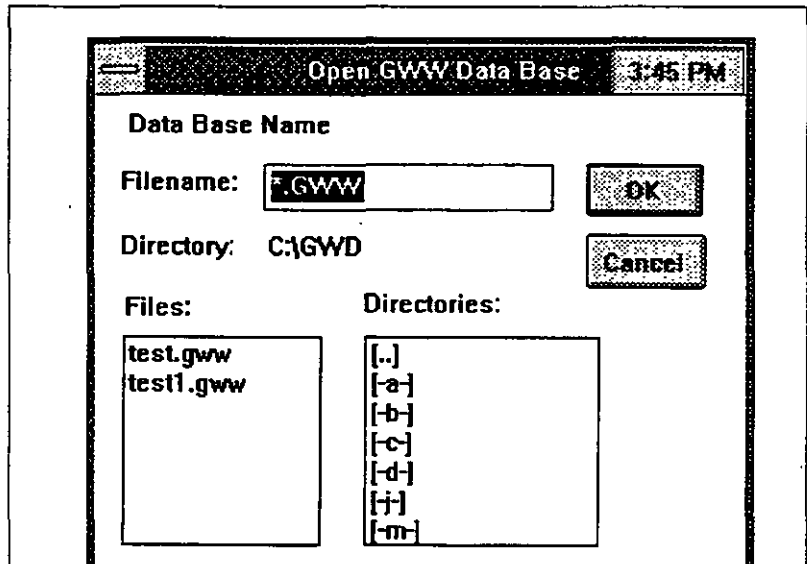

Figure 2-3



NOTE. Be careful when prompted for a data base name. If you select option New GWW Data Base and give a name of an existing data base, all file structure, input and output forms, data base content, and all objects that make this data base will be erased. You will start from a brand new data base using the default template GWW.000. However, the program will warn you and stop you from accidentally erasing an existing data base.

At this moment the GWW program will read in the template data base structure, GWW.000, and use it as the starting point for your new data base. You will learn to modify some of default data structures in the section which follows.



NOTE. Remember again that you may customize the template GWW.000 and use it repeatedly with data structure, and various forms set up to make your work tailored to your needs.

2.3.3. Editing an Existing Data File Structure

For each of the major applications, the GWW package already contains a preprogrammed standard data file structure. The list of data base constituents is shown in Section 2.2.1. for the master data, and in Appendix B for chemistry, hydrographs, lithology, pumping tests, step drawdown tests, and grain size distribution curves.

To modify an existing data structure file you should follow this sequence of operations:

1. Select **Tools** from the menu bar. The menu as shown in Figure 2-4 opens.

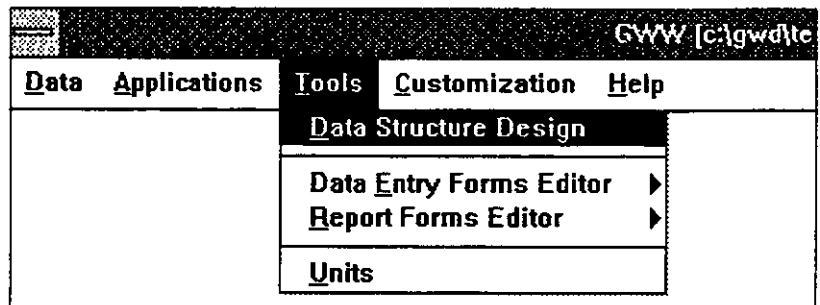

Figure 2-4

2. Select **Data Structure Design**. Wait until the menu bar displays two options: File and Help. You are advised to explore the Help menu. This Help is dedicated to the File Structure Design editor.
3. Click on **File**. The menu opens as shown in Figure 2-5. You will notice the following options: Old, New User File, Old User File, Exit, Create Structure From STD ASCII, and Write Structure to STD ASCII. STD is short for Standard. Forget for the time "User Files."

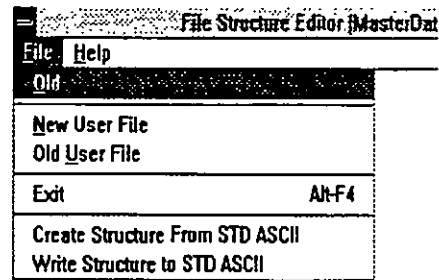

Figure 2-5

4. Select **Old**. The dialogue box as shown in Figure 2-6 is displayed. The box is titled "Select an Existing File" and lists all pre-programmed structure files for all applications.

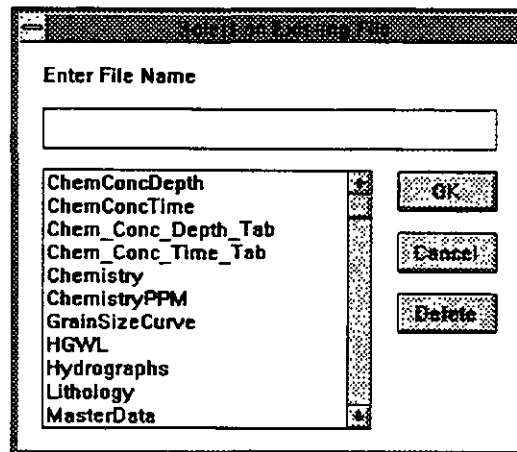

Figure 2-6

5. Select with the mouse the application you wish to modify and either double-click the mouse or click it once and press ENTER.
6. If you have selected the 'MasterData' file (data structure for master data application), the screen will display the dialogue box as shown in Figure 2-7. You may notice the list of data items, their types, length, number of decimal points, and eventually units. The

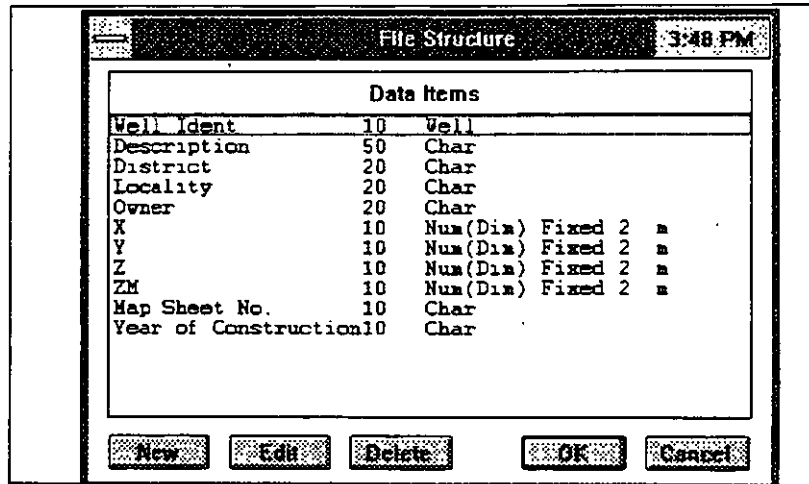

Figure 2-7

box will contain several buttons the role of which is clear: New, Edit, Delete, OK, Cancel.



NOTE. Remember that these files are not ASCII files, but internal files associated with the data base that you have opened. Any modification will be kept internally and will affect only the data base currently in use.



EXAMPLE ONE

As an example, we will modify the existing data structure file for chemistry. Our task will be the following:

- (1) Accept all data base items that are offered by default, except fluorine.
- (2) Add toluene with minimum content of 0.001 ppm and benzene with minimum content of 0.01 ppm.
- (3) Reduce the number of decimal digits for chlorine from 2 to 1.
- (4) Rename Well Ident with Well Number.



- (5) Rename Conductivity with its Spanish equivalent, Conductividad. (This is to demonstrate language-versatility of the software. However, notice that the word Conductivity is used by GWW to create the Wilcox diagram. When you change it, the diagram will not be created.)

You should follow the procedure as explained below.

1. Select **Tools** from the menu bar.
2. Select **Data Structure Design**.
3. Click on **File**.
4. Select **Old**. The dialogue box as shown in Figure 2-6 is displayed. Notice **Select an Existing File** in the title bar.
5. Click on **Chemistry**. It will be highlighted, and the name **Chemistry** typed on the command line, as shown in Figure 2-8. Press Enter, or click on the com-

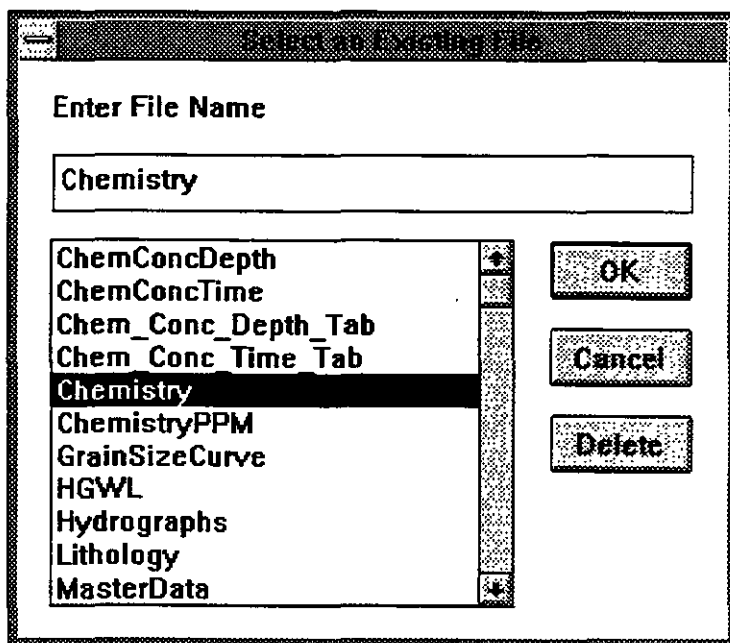

Figure 2-8

mand line, or click on OK. One portion of the chemistry data structure file will be displayed as shown in Figure 2-9.

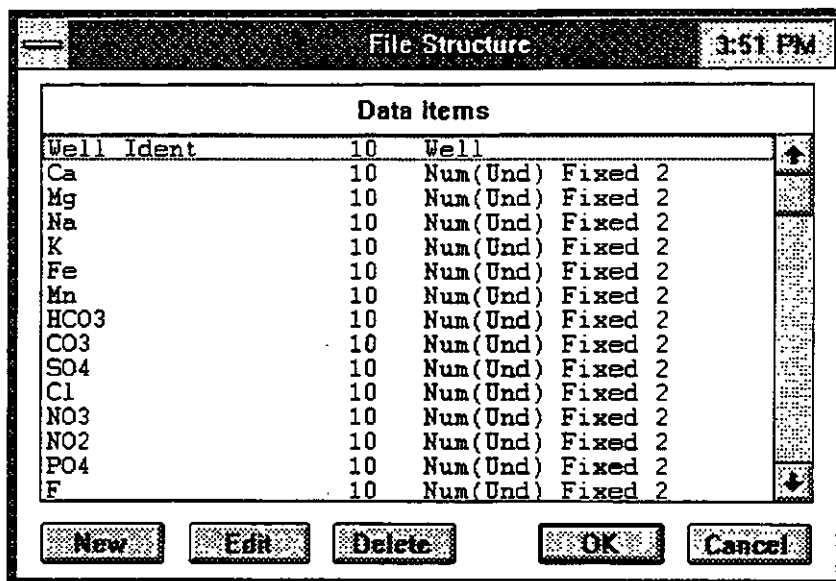

Figure 2-9

- Find fluorine and click the mouse on its line. Fluorine is highlighted. Click on **Delete** button at the bottom of the screen. Fluorine disappears from the list of constituents.
- Click on the **New** button. The familiar dialogue box with **New Field** in the title bar is displayed. Type the word Toluene and either press Enter or the Tab key to move to the next line, **Field Length**.



NOTE. Remember that you must terminate the input by either pressing OK or using the Tab key. Whatever you typed will not be saved if you terminate the input by pointing the mouse to and clicking in another field. This applies equally to data input, data editing, creating data forms, and creating data structure files. It is one of the major conventions of data input using Windows.

Anticipate the minimum toluene content of 0.001 ppm and maximum of 99. Replace the default field length of 10 with 6. Click on Numeric. Do not use Numeric(Dim) since the chemical data default is equivalents per millions (epm), or parts per million (ppm), depending on



which option you have selected when starting the input. You may always switch between ppm and ppm. Replace the default number of decimal digits (2) with number 3. Click on OK. Notice that Toluene has been added to list of constituents on the last line.

8. Do the same for benzene. Click on **New**, type Benzene for Field Name, 6 for Field Length. Select Numerical for Data Type, and change 2 with 3 for Number of Decimal Digits. Click on OK.
9. Highlight Cl. Click on **Edit** button. Click on OK. Replace 2 with 1 in the number of decimal digits field. Click on OK.
10. Highlight Well Ident and click on **Edit** button. Replace the word Ident with the word Number. Press Enter or use the Tab key. Click on OK.



NOTE. The Well Ident is a special field, the name of which is used by the program to connect different parts of the data base. Actually, this entry is used to create a relational data base. You will notice that 'Well' is one of the data types, in addition to character, numeric (nondimensioned), numeric (dimensioned), data, time, and comment (see Figure 2-7). If you change the well identification in the chemistry data structure file, you must do the same in all other data structure files. Be very careful and ensure that you have done this in an absolutely identical way.

11. Highlight the line Conductivity. Click on **Edit**. Replace the word Conductivity with Conductividad. Click on OK. The final display at the end of this exercise looks as shown in Figure 2-10 (upper part), and Figure 2-11 (lower part).
12. Click on OK. You will be back in the File menu. The changes are automatically recorded in your data base.
13. Click on Exit, then on Data, and Exit again. This will terminate the modification to your chemistry data structure file for the data base currently selected (Example.gww). Remember, what you do in this example affects only your currently opened data base! You



File Structure					4:02 PM
Data Items					
Well Number	10	Well			
Ca	10	Num(Und)	Fixed	2	
Mg	10	Num(Und)	Fixed	2	
Na	10	Num(Und)	Fixed	2	
K	10	Num(Und)	Fixed	2	
Fe	10	Num(Und)	Fixed	2	
Mn	10	Num(Und)	Fixed	2	
HCO3	10	Num(Und)	Fixed	2	
CO3	10	Num(Und)	Fixed	2	
SO4	10	Num(Und)	Fixed	2	
Cl	10	Num(Und)	Fixed	1	
NO3	10	Num(Und)	Fixed	2	
NO2	10	Num(Und)	Fixed	2	
PO4	10	Num(Und)	Fixed	2	
B	10	Num(Und)	Fixed	2	

New Edit Delete OK Cancel

Figure 2-10

File Structure					4:02 PM
Data Items					
PO4	10	Num(Und)	Fixed	2	
B	10	Num(Und)	Fixed	2	
SiO2	10	Num(Und)	Fixed	2	
TDS	10	Num(Und)	Fixed	2	
Hardness	10	Num(Und)	Fixed	2	
Alkalinity	10	Num(Und)	Fixed	2	
Conductividad	10	Num(Und)	Fixed	2	
pH	10	Num(Und)	Fixed	2	
Cations	8	Num(Und)	Fixed	2	
Anions	8	Num(Und)	Fixed	2	
SAR	8	Num(Und)	Fixed	4	
BalErr	8	Num(Und)	Fixed	2	
Toluene	6	Num(Und)	Fixed	3	
Benzene	6	Num(Und)	Fixed	3	

New Edit Delete OK Cancel

Figure 2-11

still have the template, GWW.000, intact, in the case you want to go back and start from the default.



NOTE. Remember the Windows way of exiting an application: ALT+F4. Or, click on Data, and then on Exit. Sometimes you may experience a problem in attempting to exit using the options on the menu: Data and Exit. If this becomes a case, use the combination of keys ALT and F4.

This terminates our example number one.

2.4. FURTHER OPTIONS ON DATA STRUCTURE FILE MENU

2.4.1. Writing Data Structure to Standard ASCII Files

You may save a data structure file as an ASCII file. This option will become available only after you select an existing data file structure. Suppose you wish to delete NO₂ from the list of items in the chemistry part of the data base structure, and save the new data structure under the name chem.str. The procedure to follow is:

1. Select **Tools** from the main menu.
2. Select **File Structure Design**.
3. Select **File**.
4. Select **Old**.
5. Double click on **Chemistry**.
6. Move the cursor down to NO₂ and click on the **Delete** button. The screen display is as shown in Figure 2-12.
7. Select **OK**.
8. Notice that the title bar displays **File Structure Editor (Chemistry)**. Select **File** again. Select **Write Structure to STD ASCII**.
9. Type **Chem.str** when prompted for the file name. The display looks is as shown in Figure 2-13. The file

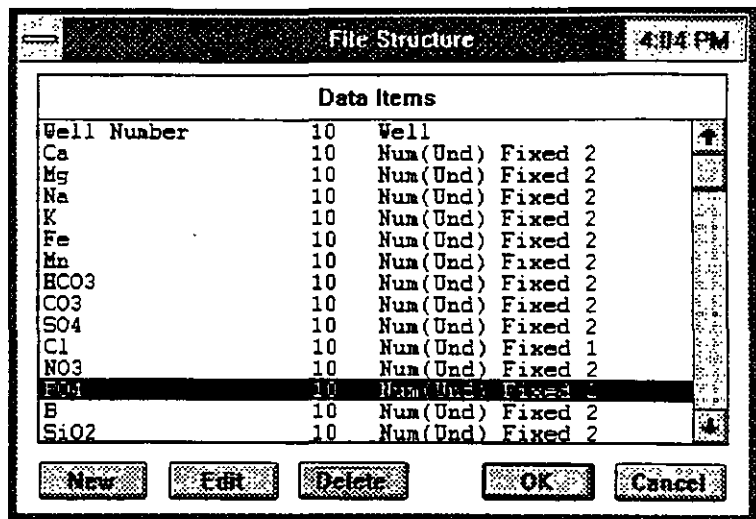

Figure 2-12

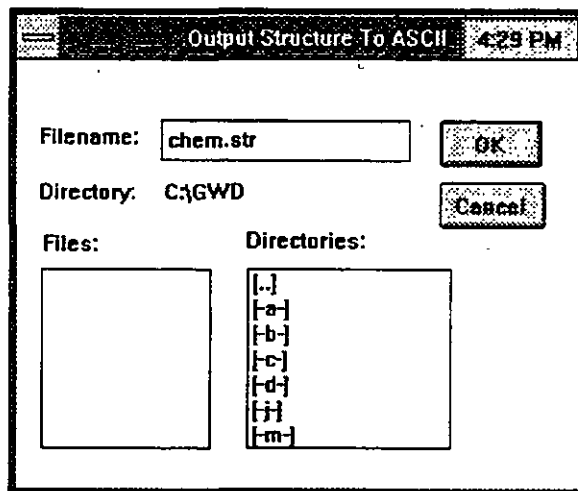

Figure 2-13

Chem.str will be a regular (standard) ASCII file, which you may edit using any text editor.

At this moment you have created an ASCII file, which will be stored in your current or working directory, and you have also modified your data base internally.

2.4.2. Creating Data Structure from Standard ASCII Files

You may also import an ASCII data structure file and replace your standard file with the new file. For example, if you wish to replace [in another data base] the standard chemistry data structure file (built into the template GWW.000) with the file you have just created, Chem.str, proceed as follows:

1. Select **Tools** from the main menu.
2. Select **File Structure Design**.
3. Select **File**.
4. Select **Old**.
5. Select **Chemistry** to let the program know that you wish to replace the Chemistry data structure.
6. Click on **OK**. This brings you back to the File sub-menu. Notice that the window is identified with File Structure Editor (Chemistry).
7. Select **File** again. Select **Create Structure from STD ASCII**.
8. Select one of file names from the dialogue box. In your case there will be only one file name, Chem.str, as shown in Figure 2-14.

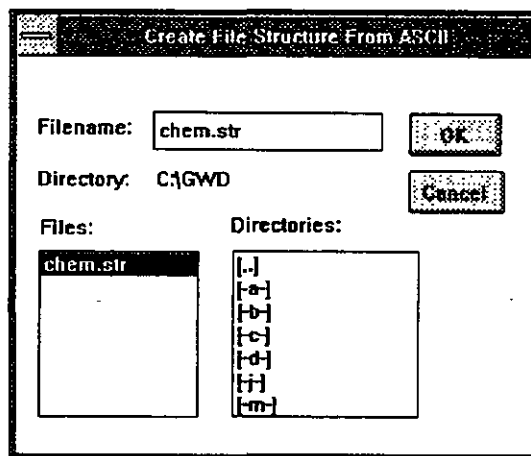
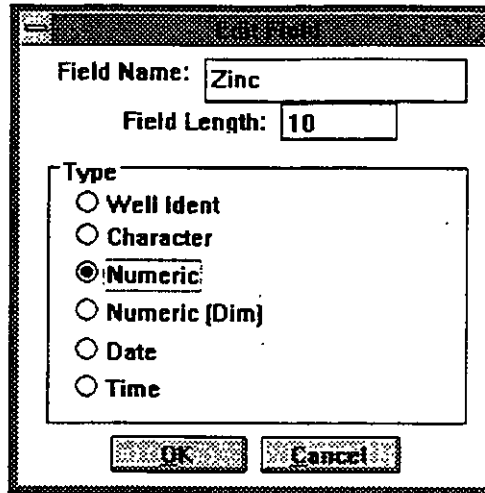

Figure 2-14

9. Check its content, edit it if you wish to, and exit by clicking on **OK**. To see some options in the editing of data structure we will add Zinc content to the list.
10. With the data fields listed, as shown in Figure 2-12, click on **New** button and type Zinc for field name. The dialogue box is as shown in Figure 2-15. Click on



Field Name: Zinc

Field Length: 10

Type

- Well Ident
- Character
- Numeric
- Numeric (Dim)
- Date
- Time

OK Cancel

Figure 2-15

Numeric box. Remember that the concentration of a chemical constituent is a nondimensioned numerical value. After you click on **OK** the dialogue box as shown in Figure 2-16 is displayed.

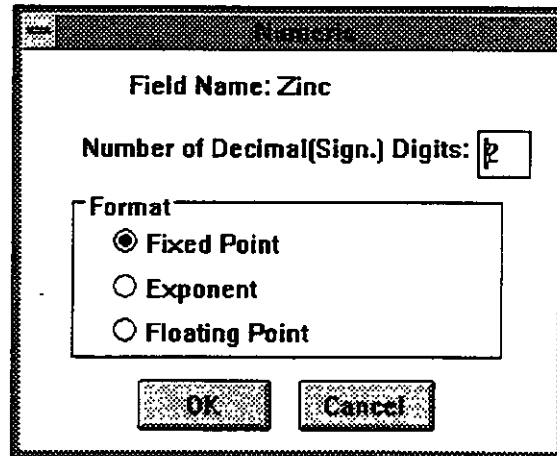

Field Name: Zinc

Number of Decimal(Sign.) Digits: 2

Format

- Fixed Point
- Exponent
- Floating Point

OK Cancel

Figure 2-16

11. Notice different options for the data format: floating point, exponential, and fixed point. As an example, the number 25 will be typed as 25.00 if the fixed point format with two decimal digits is selected, or as 25 if the floating point format is selected. It will be typed as 2.5E+01 with the exponential format.
12. Click on OK to terminate this operation, then again on OK to close the data structure editing dialogue.
13. Select Exit to return to the main menu.
14. Select **Data** and **exit** again to leave the GWW program.

SUMMARY OF THIS CHAPTER

When you open a new data base the default data file structure as contained in the \GWW program directory under the template file GWW.000 is used. Whether you modify a parameter or not, this data file structure becomes associated with the data base name you gave to the base. When you open this data base next time, the program does not read the default structures from the \GWW directory but uses its internal data file structure.

You may replace the standard data file structure by either editing one or more of the data structure files, or by reading an input ASCII data structure file. When you read an ASCII file and save it, it replaces whatever was before declared as data file structure.

You may modify the data file structure in an existing data base with or without data typed in. GWW will first copy your data into an internal backup file, so that you will not lose data. However, it is advisable to first copy all information in ASCII files using the option **Standard ASCII Output** that is available in every application. Once you have modified your data file structure, you may read these ASCII files if you did lose accidentally

some data because you modified either field name or any other attribute.

Remember, at the end, that all data processing and data management that follows is related to what you have declared in the data structure internal files. You will be able to come again to this utility even if you have created a data base and typed data in. A careful planning of your intended data input and the ways in which the data will be reported, displayed or presented, reduces greatly the risk of losing data or wasting the time searching for inconsistencies.

3.1. CONCEPT OF FORMS**3.1.1. General**

This chapter introduces the *Form Tool*. It is located on the main menu bar, **Tools**, as a submenu under two names: *Data Entry Forms Editor* and *Report Form Editor*. You will use one or the other depending on whether you wish to create and/or edit data entry forms or data reporting forms. The emphasis of this chapter is on creating your own forms.

There are two major group of forms: data entry form and report form.

Data entry form editor is activated as follows:

1. Select **Tools** from the main menu bar (see Figure 2-4).
2. Select **Data Entry Forms Editor**.
3. Select an application for which you wish to change or create an entry form.

Data reporting form editor is activated as follows:

1. Select **Tools** from the main menu bar (see Figure 2-4).
2. Select **Report Forms Editor**.
3. Select an application for which you wish to change or create a reporting form. Notice that the menu continues prompting you to choose between a single record or a table or group record.
4. Select single or table (general data) report (see Figure 3-1).

The single report form refers to an individual well or sample. Table report form refers to tabulated data from more than one well or sample. However, in the pumping test application, there can be a table of pumping test

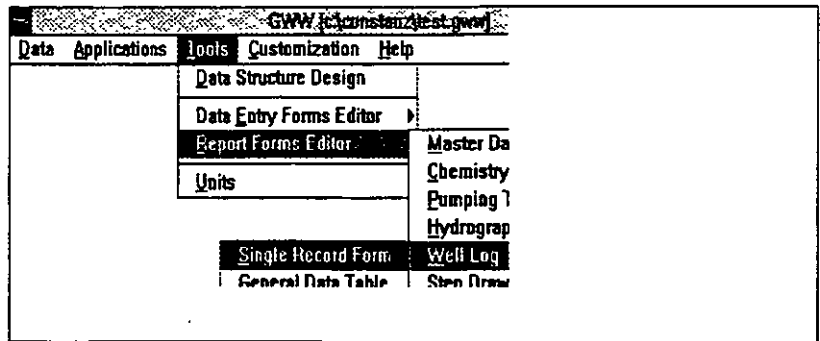

Figure 3-1

measurements (time, drawdown, pumping rates) for one single well, as well as a table with pumping test results (transmissivity, storage coefficients, etc.) for many wells. The first will belong to the group of single reports, and the second to the group of table reports.

Since the GWW package treats data as objects, you can place objects on a form, whether entry or reporting, according to your own design, or you can use predesigned forms. The predesigned forms are built into the data base template, GWW.000. These are internal files, which you can retrieve (using option Old in the sequence Tools/Data Entry Forms Editor/Form/Old) and modify. You may also copy them to standard ASCII files and save them on the disk.

Once saved, you may edit them with a text processor, and read them into the new data base.

The master data entry form from the GWW.000 template is reproduced in Appendix C. This master data entry form, when activated by the GWW program, displays the screen as shown in Figure 3-2.

3.1.2. Entry Form Screen

The Form Editor splits the screen into two windows: list-of-fields window on the left and form-editing window to the right. In the left window, fields that can be selected for the form are listed. The left window has one, two or three parts, vertically split, depending on the kind of form selected:

- single fields (with a list of all single fields)
- columns (with a list of column fields, which make a table)
- drawings (with a list of drawing fields, such as a STIFF diagram, a hydrograph, well log, etc.)

The screenshot shows the 'Form Editor' window with a menu bar (Form, New Field, Attributes, Options, Help) and a toolbar. The main area is titled 'Standard' and contains a 'Master Data' form. On the left, a list of fields is shown: Well Ident, Description, District, Locality, Owner, X, Y, Z, ZM, Map Sheet No., and Year of Constr. The form layout includes a header 'Master Data', followed by fields for 'Ident', 'Description', 'Easting', 'Northing', 'Ground Surface Elev', 'Measur. Pt. E', 'District', 'Locality', 'Owner', and 'Map Sheet No.'. A small dialog box is open over the form, showing 'Type:', 'Label:', 'x,y [mm]', and 'dx,dy'.

Figure 3-2

The Form Editor reads field names from internal data structure files which are a part of either the GWW.000 template for a new data base or your own data base. For example, if you open a chemical entry form for an individual sample, the list of data items the will be displayed on the left will be directly copied from the chemistry data structure file, plus the items from the master data structure file.

3.1.3. Entry Form Selection

You may select an existing form or create a new one by clicking on Form on the Menu bar (or by typing ALT F). The following options are offered:

- New
- Old
- Save
- Save As ...
- Clear Form
- Standard ASCII Input
- Standard ASCII Output
- Print
- Exit

You will select **New** if you wish to create a new form. If you wish to use one of existing forms (old forms) you will select **Old**. In this case a dialogue box will open offering you a list of existing forms.

Any form that you select or create can be saved as an ASCII file if you select the option **Standard ASCII Output**. You may also read an existing ASCII form file by selecting the option **Standard ASCII Input**. You may print any form that is currently displayed and used by selecting the option **Print**. If you use a color printer the fields, labels, or headers may be printed in colors.

3.1.4. Content of a Form

The content of "Single Fields," "Columns," and "Drawings" listings depends on the type of form and application for which the form is intended. The form is created by selecting one or more nontextual fields, columns, and/or drawings. Textual fields are selected or created from the next entry on the menu bar, **New Field**. When the Form Editor is activated, a list with all possible fields from this and the Master Data application is automatically created depending on the application and the type of form.

3.2. STANDARD FORMS

Each of the main modules has its own standard form pre-designed by the programmer. For the master data entry form, for instance, the data item name such as X and Y has been replaced in the entry form with the words Easting and Northing. The ground surface elevation data field, labeled as Z in the data structure file, is labeled as Ground Surf Elev in the entry form. You may modify this, and save the modified data entry form as standard, or under a different name. Again, you may use your own language, provided you have font types, and create your entry form in a language other than English.

Examples of standard data entry forms are shown in Figure 3-3 for chemistry, and in Figure 3-4 for well construc-

Figure 3-3

tion and lithology.

One example of a "foreign" language data entry form for master data is shown in Figure 3-5. It is created using Serbian language and Latin font. On the left, the list of data items is written in English, but it could have been created in Serbian as well, using **Data Structure Design** option. Items could have also been written using official Serbian alphabet with Cyrillic characters.

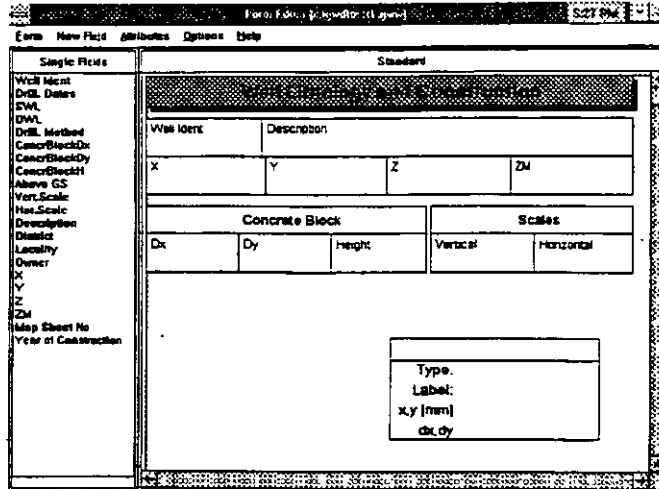

Figure 3-4



Do not forget the difference between a Field Name assigned by you in a Data Structure File using the data structure file editor (see Chapter Two, section 2.3.2.) and Field Label used in the Form Editor. The first cannot be changed. It uniquely defines an item or a piece of information. It is the basis of a data base. You use these field names to create your forms. Once selected to be placed on a form, each field label can be replaced by an-

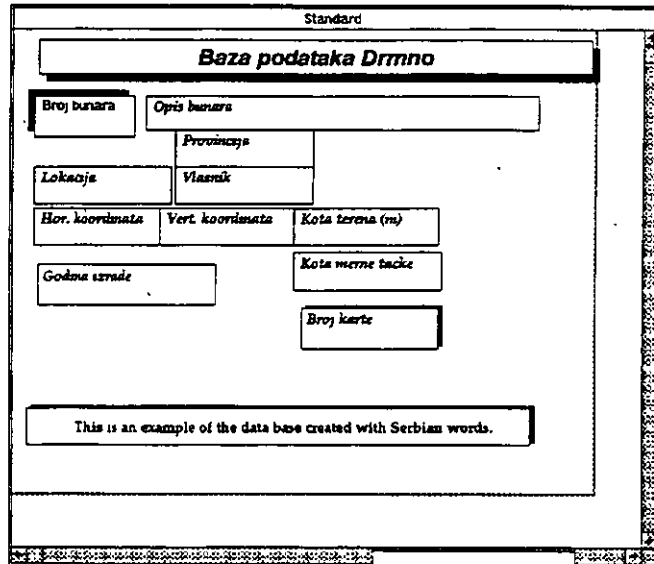

Figure 3-5

other name, text, or font. Look at Figure 3-2. The data field with the name X in the data structure file (horizontal coordinate) is labeled Easting on the entry form. However, this item will be cross referenced in each and every application by referring to its data structure file name, which is X.

3.3. REPORTING FORMS

3.3.1. Types of Reporting Forms

The types of reporting forms available depend on the application, since each application generates different types of report. However, two types of reporting forms are common to all applications:

- Single record form
- Table form

These expressions appear only on the **Master Data** option, while in other applications the labeling (terminology) is modified to better accommodate an application. Regardless of the application, these forms have common properties.

There is a special category of reporting forms, **Nonstandard Forms**, which is used to mix graphics among various applications.

3.3.2. Single Record Forms

Single record forms are created for printing information for a single well, single chemical analysis, or a single hydrograph. The fields that may be included in such a form are the following:

- all fields declared in Master Data (identification, location, coordinates, elevation, etc.); and
- all fields declared in a particular application.

In addition, columns and drawings are also included. For example, in the Chemistry application, one analysis may report constituents and various parameters, plus a STIFF diagram; in the Hydrographs application, a well may report a table with measured data, plus a hydrograph in a "drawing" field.

3.3.3. Group Record Form

A group record form includes information from more than one well. A typical example is a PIPER diagram which presents a table (Column) with well/sample identifications, plus a drawing containing a PIPER diagram with all selected samples. Prior to creating such a group report, you should select a working group. This is a subset of all information in your data base on which you wish to work and present in a group report. Fields which are "Single" in single record form are "Columns" in group record form.

3.3.4. Hydrograph Report

This is a report of the single report type. It is made of columns which contain measured data and a graphics field for a hydrograph.

3.3.5. Hydrograph General Table Report

This is a report of a "table form," with general information and data from the Master Data entry form.

3.4. FORM EDITOR

3.4.1. Elements of a Form

Frame

Frame is a rectangular outside edge of a form, which can be edited by **Attributes** from the Menu bar, using the option **Setup Frame**. This rectangle is displayed on the screen but it is not printed on the report form. In Setup Frame option, which is located at the end of **Attributes**, the following frame parameters are offered:

- Horizontal offset
- Vertical offset
- Width
- Height

If you intend to print your reports on a "11" by 17" or an A3 format printer, you may select the width and height parameters accordingly. You should select the frame according to the printer you intend to use. You may orient your report as portrait or landscape and select the frame width and height accordingly.

Sizing and positioning a frame

Frame is used for positioning and sizing a field in the following way:

- Activating the Form Editor a default frame is used which is different for entry and reporting forms.
- The existing frame can be edited using the option **Attributes**, followed by **Setup Frame**.
- When a new data field is generated, the Form Editor will automatically assign its size and will position it to the right of the last field **provided it fits the frame**. If not, it is placed into the next line. In this way the horizontal size of the frame is used as a default for locating fields.

- When a header is defined, its width is equal to the width of the frame and it is positioned at the top of the form.
- When a drawing field is defined, it is located to occupy the whole width of the frame immediately underneath the last field. The Editor assumes that the drawing will occupy the rest of the page until its bottom.
- When a column field is defined, its width is selected considering the number of digits or characters defined in the reporting form; its height is such that it occupies the whole vertical space down to the bottom of the frame.

Rulers

On the Form Editor menu bar under **Options** you may select to display form rulers. This is a switch which turns rulers at the top and left edges of the screen on (**Show Rulers**) or off (**Hide Rulers**). The on-screen rulers help position fields and graphics. The measurement unit for both the horizontal and vertical ruler is millimeters by the default.

Identification Window on the Form

You will notice a rectangle in the right lower corner of the screen which identifies the type of a field (field name for data, text, or graphics), the field label, the x and y coordinates of the upper left corner of the field in millimeters, and the length and the width of the field. This may be very useful in editing a form.

Display Full Form or Normal Display

At any moment when you are in the Form Editor you may select to display the full form or you may work with the normal display. This will depend on what size of the screen you have. On a 20-inch monitor you may work all the time with full display, but on a 14-inch monitor the normal display is your only chance! In the Display Full Form mode some fonts may not appear right. Do not be alarmed. This is only in viewing the form, not in printing a report. (At some time, the Form Editor is not truly WYSIWYG.)

3.4.2. Adding Field to a Form

New Field on the Menu bar offers three options:

- Add Header
- Add Text Field
- Add Drawing Field

The Drawing Field will not be available in Entry Forms editing.

3.4.3. Text Field Attributes

A text field may have the following attributes:

- Field Name
- Border
- Background
- Field Label
- Label Font
- Label Color
- Label Alignment

You may only add or modify the attributes of an active field. Only one field can be active at a time. You activate a field by moving the mouse inside the field and pressing the left mouse button. If this does not work, move the mouse outside of any field, click it once, then move the mouse inside the field you wish to work on and click the mouse again. (The first method will not work if the field you wish to activate is placed within another field. Then you must deactivate the larger field by clicking outside of it.)

3.4.4. Field Name

Field Name is a text string which uniquely identifies an entry field. It is important in creating a reporting form to use the same text string for a reporting field. For exam-

ple, if in the chemistry entry form the field that will input the alkalinity values of a water sample is typed as Alkalinity, the Field Name in a reporting form must be typed exactly the same (case-sensitive, exact number of characters or blank spaces).



NOTE. Remember again, that in the Form Editor mode you must not modify field names. If you do it, you should also modify data field names in Data Structure File Editor.

3.4.5. **Border**

Border includes the user-defined solid frame around a field and shadowing of the field. Borders can be thin or thick, as specified by you; they may include full frame or just one of the four lines (left, right, top, bottom), or none. Shadowing can be thin (number 1 or 2) or thick (numbers 3 and 4).

3.4.6. **Background**

Background refers to the color selected by you to paint a field. The whole color palette provided by the Windows is available. Each field can be painted.

3.4.7. **Field Label**

Field Label refers to the text typed to identify a field. Here is the possibility to use languages other than English. Although a field may be identified with **Field Name**, say conductivity, the field label may be typed in Spanish as Conductividad. Unless you change it, the field label will be identical to the Field Name selected in creating a form.

3.4.8. **Label Font**

Label Font is user selectable. Whatever comes with Windows can be used. The selection is standard as explained in the Windows manual, that is you may select the font, the size (points), and style such as bold, normal, or italic.

You may use various fonts such as Cyrillic, Arabic, Greek, Hindi, etc.

3.4.9. Label Color

Label Color is also user selectable. Each and every label can be colored differently. You may select the color by sliding the three slides (R,G,B) or by directly selecting a color field from the palette.

3.4.10. Label Alignment

Label Alignment is used to align the label either as left or right aligned or centered. The label can be placed on top, center or bottom of the field.

3.4.11. Options

Options let you select to have a ruler displayed with the form and/or to display the full form, as discussed earlier. Rulers extend beyond an A4 or legal paper formats.

3.5. CREATING A NEW FORM

In this section the general procedure in creating a new form is explained. The example which follows will give you a better feeling for this routine supported by screen displays reproduced in the manual.

1. Select **New** from the Form menu.
2. From **Single Fields** window, select fields you wish displayed in your entry form.
3. Start with **Well Ident**. Notice where the field will be displayed.
4. To modify its attributes select **Attributes**.
5. From the Attributes menu select **Border**. Notice two options: **Frame** and **Popup Shadow**. With **Border**, you may make a frame around the whole field, or with one, two, three, or no lines. You may also control the frame line thickness. With **popup shadow**, you may have a pair of shadow lines (left and bottom, left

and top, right and bottom, right and top). You may also assign the shadow thickness.

6. Stretch the field, if you wish, by clicking on one of the corners of the field and by dragging it with the mouse. Move the whole field to another location by clicking in the center of the field and by dragging it to the new location.
7. Continue with another data field.
8. Add a header. Normally the header should indicate the form name and the project name.
9. Select **New Field**.
10. Select **Add header**.
11. Type the text for field header. GWW uses for a header the default font: Arial, 16 points, and bold style.
12. Change the label font by selecting **Attributes and Label font**.
13. Move the header to a suitable location by dragging it with the mouse.
14. When you are finished, select **Form** and **Save as ..**
15. Type the name you wish this new entry form to be saved under.

3.6. SELECTING AND EDITING AN OLD FORM

To select an old form:

1. Select **Form**.
2. Select **Old**.
3. From the dialogue box labeled as **Load Form** select one of the existing forms. Normally only the standard form will be offered when you start the program. You may create many more forms and select one of your own forms. Double click on Standard or click once on Standard and click on ENTER. The standard entry form will be displayed.

4. Click with the mouse outside the form. Then click on a field you wish to modify. You will notice that the solid line around the field becomes dotted. Now you can select **Attributes** and any of the attributes on the pop-down menu, such as label font, label color, data font, etc. These attributes refer only to the field which has been selected. You may move the field to a new location, or size it. You may enhance the whole field by selecting background and selecting a color from a color palette.
5. When you are finished, select **Form** again.
6. Select **Save as...** and give the new or old name for this entry form.

3.7. READING FROM AND WRITING TO AN ASCII FILE DATA ENTRY FORM

3.7.1. Reading From an ASCII File

You may read an entry form file created and saved as an ASCII file. For example, if you have created an ASCII entry form file and have given it the name MASTER1.FRM, you may retrieve it as follows:

1. Select **Tools** from the main menu bar.
2. Select **Data Entry Form Editor**.
3. Select **Master Data** application.
4. Select **Form** from the menu bar.
5. Select **Standard ASCII Input**.
6. Select the filename MASTER1.FRM from the list of filenames in the dialogue box.

3.7.2. Writing to an ASCII File

You may create your own entry form and save it as an ASCII file. The following procedure creates an ASCII entry form file with the filename MASTER1.FRM.

1. Select **Tools** from the main menu bar.

2. Select **Data Entry Form Editor**.
3. Select **Master Data** application .
4. Select **Form** from the menu bar.
5. Select **New**.
6. Create your own entry form from the fields offered on the left side of the window, using new fields for headers.
7. Select **Standard ASCII Output**.
8. Type MASTER.FRM as a new filename in the dialogue box.

3.8. PRINTING AN ENTRY FORM

You may print the entry form which is currently selected.

1. Select **Form** from the menu bar.
2. Select the default form or an old form; create your own by selecting **New** or input an ASCII entry form.
3. Select **Print**. The displayed entry form will be printed.



NOTE. You cannot select a printer or print orientation from this utility. You must first check which printer has been selected in either one of applications or in the Windows Control Panel.



3.9. EXAMPLE

3.9.1. Create a New Master Data Entry Form

EXAMPLE TWO

The task will be to create a new master data entry form. Since there will be a lot of activities in creating the form, individual tasks will be specified at the beginning of each activity.

1. To start this exercise, select **Tools** from the main menu, then select **Data Entry Forms Editor**. The screen is as shown in Figure 3-6. Click on **Master Data**. You are

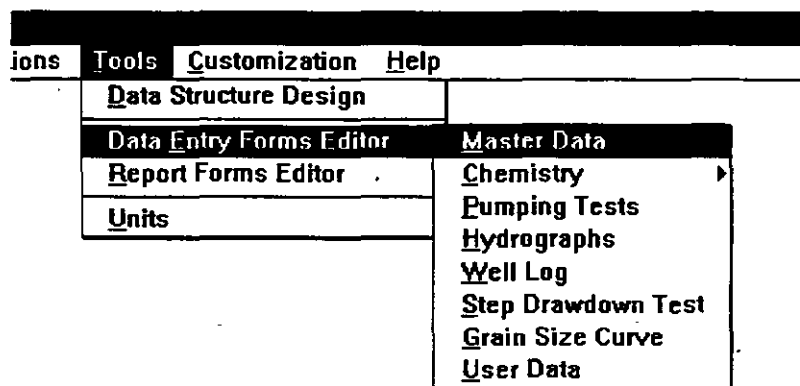

Figure 3-6

offered a blank form, Figure 3-7, with the list of all

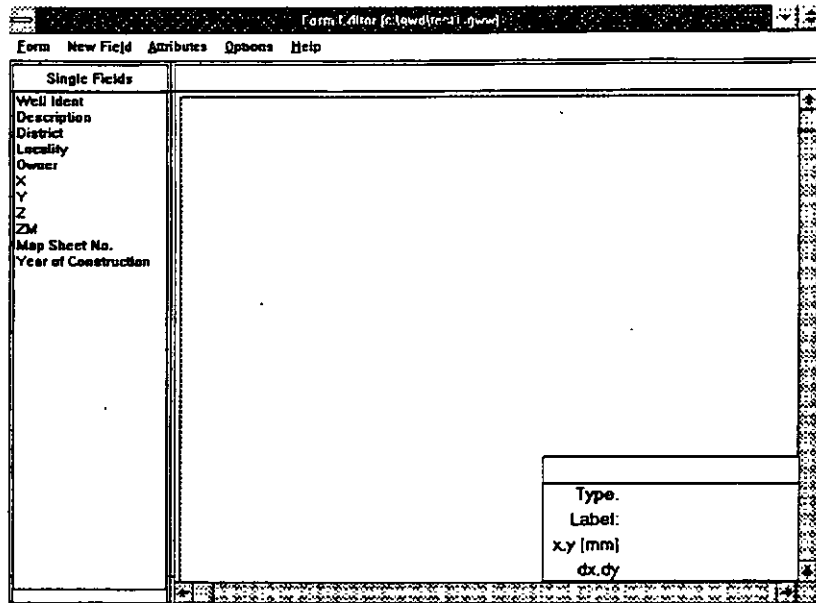

Figure 3-7

data fields on the left, and the window for a new form.

2. Start with **New Field**, to add a Header. The Header should read as follows: Master Data Entry Form - Guarico Data Base. Make the header about 2 cm high, use Times 14 bold font, add shadow to the right and above the header field. (You may also exercise with label color and background color.)

2.1. Click on **New Field**. Select **Add Header**. Type Master Data Entry Form - Guarico Data Base into the **Field Label** dialogue box. The display is as shown in Figure 3-8. Select **OK**. The header, which is now an object, is placed on the form. You will see that this

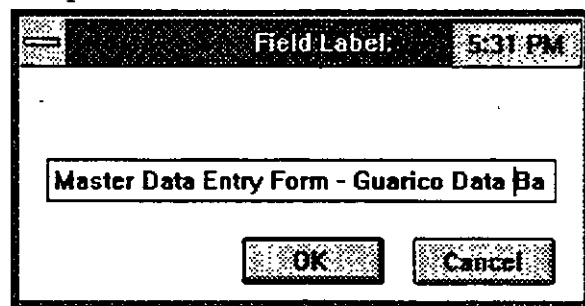

Figure 3-8



object has square handles on the corners. You can use these handles to resize the object. You can move the whole object to a new place by clicking in its interior and dragging the rectangle to a new place.

2.2. Place the pointer (mouse cursor) on the lower left handle. Click and drag the handle for about 1 cm downward. Notice that the object becomes larger.

2.3. With the object still selected (notice dashed lines,

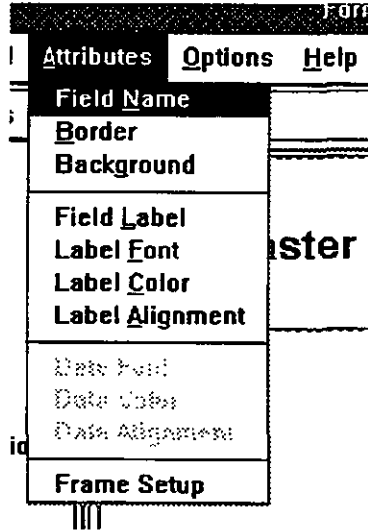

Figure 3-9

and square handles), select Attributes. The list of attributes is displayed as shown in Figure 3-9. Whatever changes you make, your action will affect only the selected object, Header field. Notice the bottom option on this menu, Frame Setup, which when clicked displays the dialogue box as shown in Figure 3-10. It refers to the entire form size and horizontal and vertical offsets. If you anticipate having more data fields, or wish to use another

layout, you may edit this form prior to continuing creating your entry form.

2.4. From the Attributes menu, select Label Font. The dialogue box, as shown in Figure 3-11, offers all fonts available to you. However, remember that the fonts that are offered to you are the ones that you have installed in your Windows. The

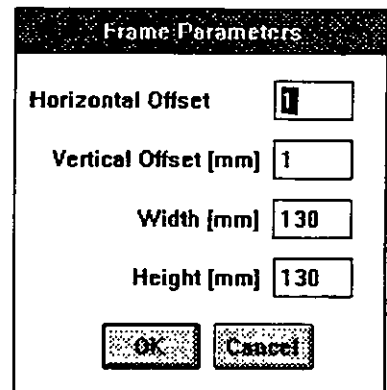

Figure 3-10



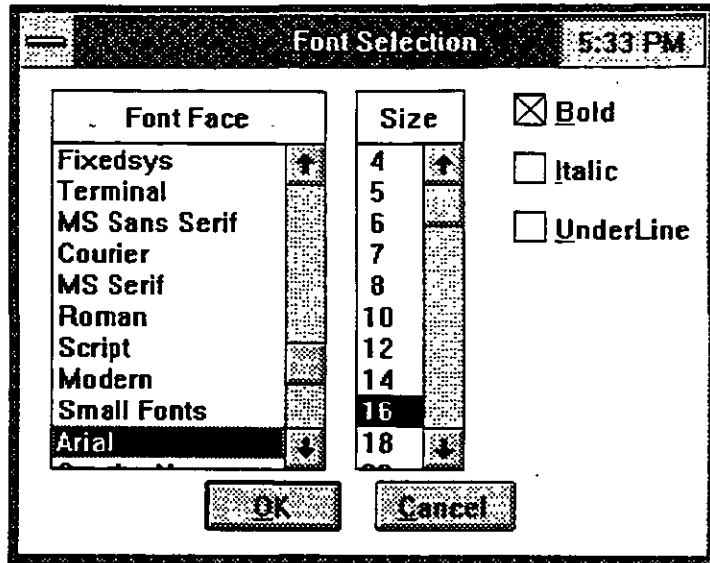

Figure 3-11

font availability has nothing to do with the GWW software. Select Times Roman, select 14 points, click on bold. Click on OK.

2.5. To add shadow, click on Border. The display is as shown in Figure 3-12. Notice two options: Frame and Shadow. Frame refers to adding lines to the field rec-

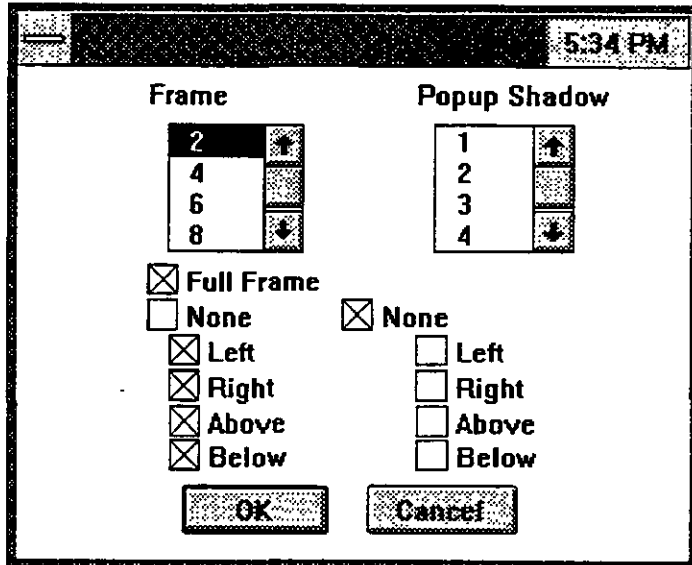

Figure 3-12



tangle. By default it has all four sides filled with solid lines of thickness 1. Shadow refers to emphasizing the form of the object. While thickness of the lines can be 2, 4, 6, 8, or 10, the size of the shadow can be between 1 and 5 millimeters. At some point during creating the form, click on Option, and place the ruler on the form. The ruler is in millimeters.

Select popup shadow by clicking first on number 3, and then on the right and above boxes. Select OK. The screen is now displaying the header field with all its attributes (Figure 3-13).

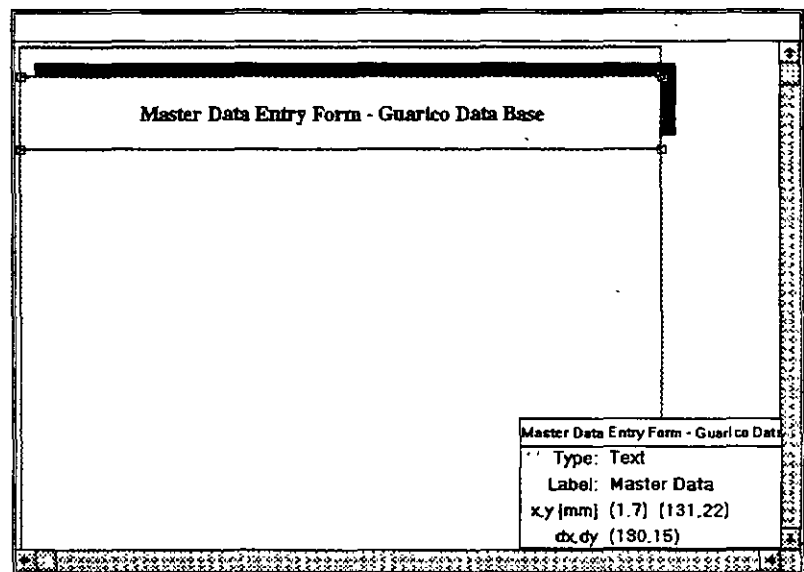

Figure 3-13

3. Add several more fields: Well Identification, Description, Location (not Locality as in the listing on the left), X Coordinate, Y Coordinate, Elevation (m AMSL), and Map Sheet No. For all use Times 10 (normal) font, except for Well Identification use Times 10 bold. Separate Well Identification from the rest with a thicker shadow frame, using left and lower shadows. Create a background color for all data fields except for Well Identification.

3.1. Click on **Options** and select **Show Rulers**.

3.2. Select **Well Ident** from the list on the left. Move the field a few millimeters down, to separate it from the Header field. Make the move by clicking inside the field and dragging the whole field. Expand the field slightly to the right. Do this by clicking and dragging the right upper handle. Try to combine both moves in one! Do it by clicking on the lower right handle and dragging it in the lower right direction until the object is the size and shape you want.

3.3. Select **Attributes**. Click on **Field Label**. Replace the word Ident with Identification. Select OK.

3.4. Select **Attributes** again. Click on **Border**. Click on 4 for frame, and on 4 for shadow, clicking also on boxes for left and below. Click on OK.

3.5. Select **Label Font**. Click on Times Roman, 10 points, and on the box for bold. Select OK to exit.

3.6. Click on New Field. Select **Add Text Field**. Do not type any text, just click on OK. Stretch this field to cover about 10 by 8 cm.

3.7. Select **Attributes** and **Background**. Select any color you want by clicking on a small rectangle in the palette. Click OK. The screen display is as shown in Figure 3-14.

Figure 3-14



3.8. Click on Description in the list on the left. Move the field into the colored field. Resize it to fit. Select **Attributes**, followed by **Label Font**. Select Times, 10 points, and click on OK.

3.9. Click on Locality in the list on the left. Move the field under the Description line. Select **Attributes**, followed by **Label Font**. Select Times, 10 points, and click on OK. Select **Attributes** again, then **Field label**, and correct Locality to Location.

3.10. Click on X on the left. Select **Attributes**, followed by **Label Font**. Select Times, 10 points, and click on OK. Select **Attributes** again, then **Field label**, and add Coordinate after X.

3.11. Repeat the same procedure with Y, changing Y to Y Coordinate.

3.12. Repeat the same with Z, typing in Field Label Elevation (m AMSL) instead of Z.

3.13. Finally click on Map Sheet No. on the left. Move the field to the lower right side corner on the form. Select **Attributes** again, then **Label Font**, and click on Times, 10, and bold. Add shadow by selecting **Border** from **Attributes**, using the number 1 for the thickness of shadow, and clicking on boxes left and below.

The final form is as shown in Figure 3-15. This terminates example two.

Figure 3-15



3.10. Nonstandard Forms

This is a special category which appears in **Report Form Editor** and in several applications (hydrographs, pumping tests, well logs, step-drawdown test, and grain size curves). It is used to create a report with several drawings from different applications on the same form. The only type of data are header, text field, and drawing fields. Each drawing is named, say PT-M1, HG-B1 (pumping test at well M1; hydrograph at well B1, etc.).

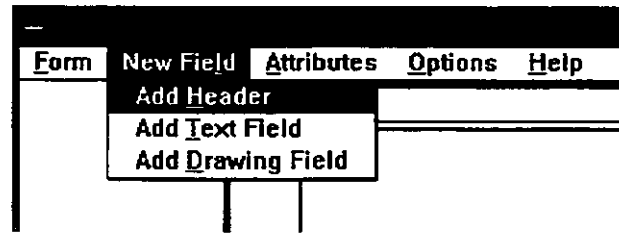

Figure 3-16

The procedure to print a composite report is the following:

1. Create a Nonstandard reporting form using the **Tools** menu and **Report Form Editor**. Notice that this is a special category which is not related to any application. Create several drawing fields and assign to each a name. Write down the names of drawings you wish to use, and their corresponding sizes (width and height). Remember that in applications you are normally asked to select a drawing' size.
2. From an application save the currently displayed graph as a drawing (use option **Reporting**, and **Save ..**). Use the same name for the drawing as the one you selected when you created the nonstandard reporting form.
3. Go to another application. Repeat the same procedure.
4. When you have created all drawings that you wish to place on that "nonstandard" reporting form, select op-

tion report from whichever application, followed by **Print Nonstandard Report**. From the dialogue box which lists all available nonstandard report forms select the one that you have created for this purpose.

One of typical examples would be to place a chemical diagram and a pumping test graph next to a well log and site location map showing the position of that well relative to other wells.

You may use the Nonstandard Reporting Form to place several graphs belonging to the same application on the same form. This applies to, for example, hydrographs, pumping tests, or well logs.

This page intentionally left blank.

4.1. GENERAL

The GWW software package has a very flexible system of units. You may use a default system, which is created by the programmers of the GWW, or you may replace this system with your own system.

In the GWW software the following terminology is used:

- unit type
- unit
- conversion factor

4.1.1. Unit Type

Unit type is the major category of units: length, time, volume, area, flowrate, transmissivity, permeability or hydraulic conductivity are examples of unit types. Although the standard GWW units file, by default named GWW.UNT and located in the \GWW directory, contains more types such as temperature, force, velocity, pressure, energy, etc., the GWW software needs only the following types: length, time, flowrate, transmissibility, permeability, and velocity.

4.1.2. Units

Cubic meter per second, square meter, minute, gallon per day per foot, etc. are UNITS. Parts per million is also a unit.

4.1.3. Conversion Factor

Conversion factor is a multiplier which relates new (user-defined) units with basic units for a particular type

of unit. For instance, if unit type is TIME and its basic unit is SECOND and the new unit is MINUTE, the conversion factor should be $1 \text{ (second)} * 60 / \text{(minute)}$, that is 0.0166667.

4.1.4. Basic Units

Each type of units (length, area, volume, time, flowrate, etc.) must have one unit that is referred to as the BASIC UNIT. It is important that basic units for flowrate, transmissivity, and permeability are consistent with basic units for length and time. In the GWW.UNT file the basic unit for length is meter and for time second. Thus, the program expects that the basic unit for pumping rate (flowrate) is m^3/s , for transmissivity m^2/s , and for permeability m/s , regardless the fact that you may not want to use these units. (In every part of the program, in its applications, you will have a chance to select your own units for computation and reporting.)

You may create your own system of units, for example using American units. However, you will not be able to define as basic unit for pumping rate gallon per minute if you have defined foot as the basic unit for length.

4.2. WORK WITH UNITS

4.2.1. Units as a Tool

Normally you do not need to be concerned with this part of the GWW software package. Almost everything you need is already pre-programmed for you. You may, eventually, use this utility as a calculator for converting some units that you may need in other programs or in your routine hydrogeological work. Only if you wish to include some uncommon units that the programmers were not aware of, you may exploit the features of the Units Tool.

If you wish to explore or modify the units, you should do the following:

1. Select **Tools** from the Main GWW menu bar. The submenu as shown in Figure 4-1 will appear.

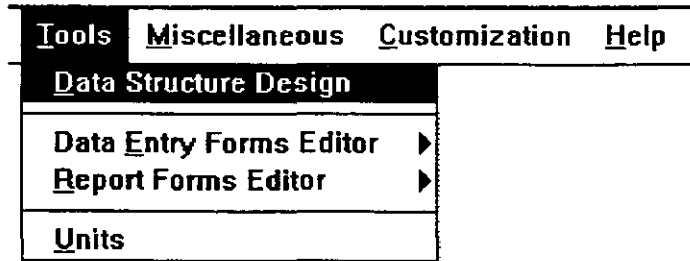

Figure 4-1

2. Move the cursor to **Units** or type letter U. The subprogram UNITS.EXE is loaded and the screen will display Unit types, Units and Factors as shown in Figure 4-2. You will notice that context-sensitive HELP is also available for this part of the program.

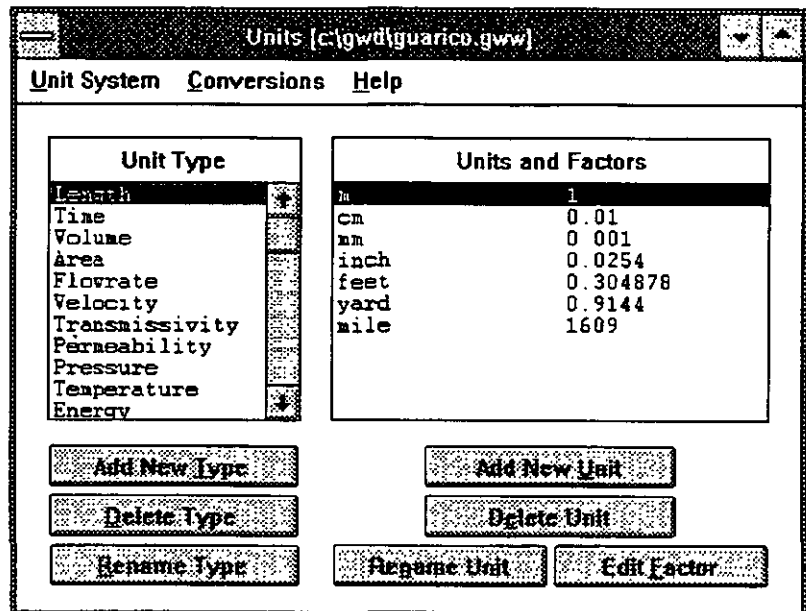

Figure 4-2

The program loads the unit system that is currently displayed using the file GWW.UNT from the \GWW directory if this is a new data base. If this is an established data base, the GWW program will associate with the base the unit system that you have worked with and have saved together with other data.

4.2.2. **Modifying Unit Type**

If you wish, for example, to change the name of a unit type you should use the button **Rename Type**. You may add a new type using the button **Add New Type**, or you may delete a type of units. As an exercise rename the type permeability with Hydr. Conductivity.

1. Move the cursor down to the line Permeability.
2. Click the mouse on **Rename Type**.
3. In the dialogue box that will open type the new name: Hydr. Conductivity.
4. Click OK.

Here, again, is your chance to replace English-written types of units with types of units in your language.

4.2.3. **Adding New Unit**

You may add new units for any unit type. As an example, prior to adding gallons per day per foot, which is the unit for transmissivity, delete the same unit from the list.

1. Move the cursor down to Unit Type Transmissivity and click on this line.
2. On the right side, where Units and Factors are displayed, move the cursor down to gpd/ft.
3. Click on **Delete Unit** button. This unit will disappear from the list.
4. Select now **Add New Unit**.
5. In the dialogue box that will open you will be prompted to type the new unit name for the Type =

Transmissivity. When you type `gpd/ft` the screen should look as shown in Figure 4-3.

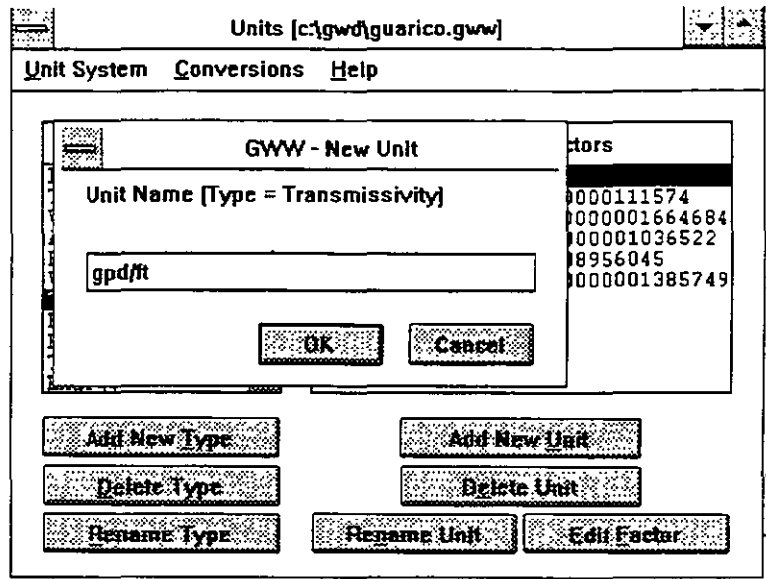

Figure 4-3

6. Click on OK.
7. A new dialogue box will open prompting you to enter a conversion factor which will relate this new unit with any other unit of this type. On the right side the list of all currently selected units for this type will be shown. For example, if you know the conversion between `gpd/ft` and `m2/day`, you may select `m2/day` using the upper and lower arrow buttons on the screen display. The screen will look as shown in Figure 4-4.

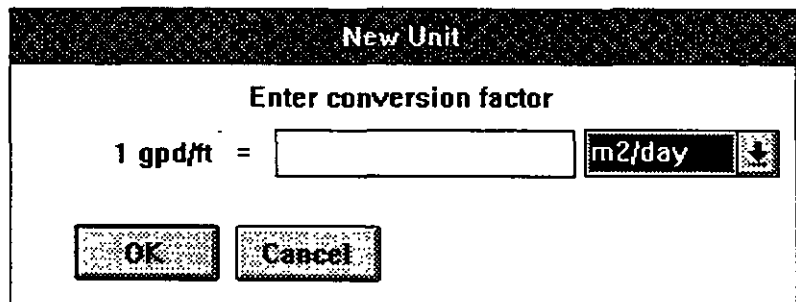

Figure 4-4

8. Select m^2/day and type .01242. The screen will look as shown in Figure 4-5.

New Unit

Enter conversion factor

1 gpd/ft = m2/day

Figure 4-5

9. Click on OK.

Although you have typed the conversion factor relating the unit gpd/ft with the unit m^2/day , the list of units and factors, which is shown in Figure 4-6, shows the conversion for gpd/ft relative to the basic unit, that is to m^2/s (see also 4.1.4 above).

Unit Type	Units and Factors
Length	m^2/s 1
Time	m^2/day 0.0000111574
Volume	$\text{g}(\text{UK})\text{pd}/\text{ft}$ 0.0000001664684
Area	$\text{sq ft}/\text{day}$ 0.000001036522
Flowrate	$\text{sq ft}/\text{sec}$ 0.08956045
Velocity	gpd/ft 0.0000001385743
Transmissivity	
Permeability	
Pressure	
Temperature	
Energy	

Figure 4-6

4.3. UNIT CONVERSION UTILITY

This is a calculator which you may use to recalculate some values expressed in one unit to their equivalents in other units. For example, you may wish to calculate length in feet. Once you are in Units subprogram you should select conversions (see Figure 4-2). The **GWV Unit Conversion Utility** as shown in Figure 4-7 will be displayed. The procedure is as follows.

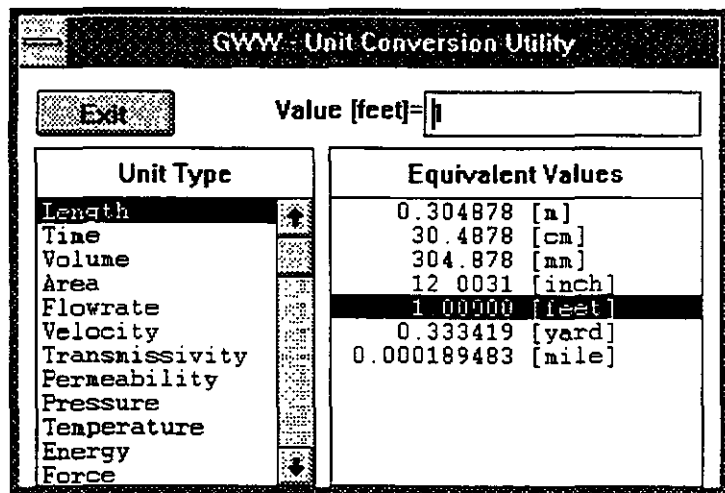

Figure 4-7

1. Move the cursor to the unit type that you wish to express in another unit. In this case select Length and click the mouse.
2. On the right side of the display, Equivalent Values, click on the line showing feet as the unit. The program automatically replaces the conversion factor with the number 1.00000 and places the same number in the upper window next to the text Value [feet]=. Replace the number 1 with any other number, say 5.77 in this example, and notice the new list of equivalent values, as shown in Figure 4-8.

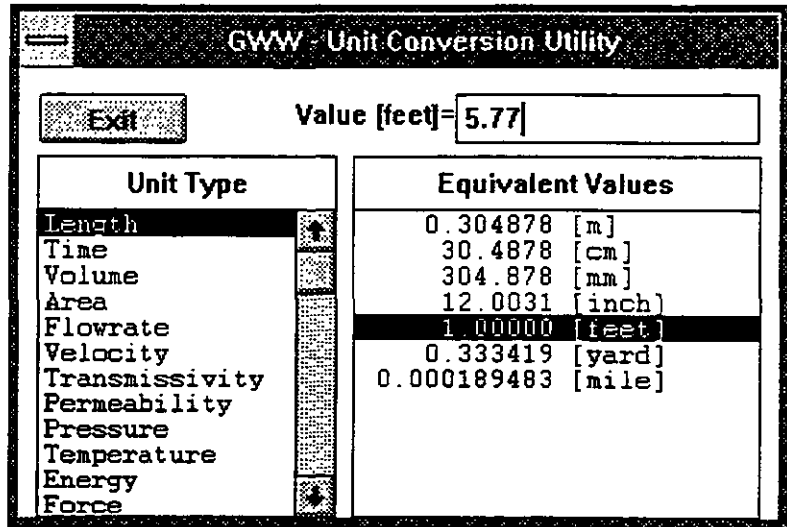

Figure 4-8

4.4. USING UNIT SYSTEM OTHER THAN PRE-PROGRAMMED FOR GWW

On Units menu bar (Figure 4-2) you will notice option **Unit System**. When you click on Unit System the display looks like shown in Figure 4-9. You have three options:

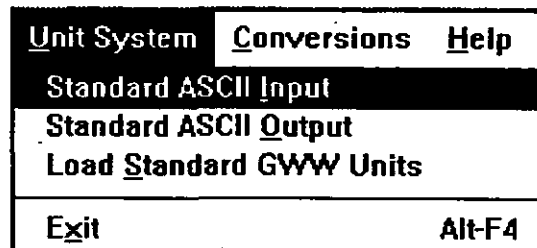

Figure 4-9

1. Standard ASCII Input
2. Standard ASCII Output
3. Load Standard GWW Units

Option one is used when you wish to read from an ASCII file another system of units than the one programmed as a default for the GWW package. Option two is used when you wish to save your current system of units in another file, which is by default an ASCII file. Option three is used when you wish to replace your currently used system of units with the GWW default or standard system.

If option one is selected you will be prompted for the ASCII file name as shown in Figure 4-10. If option two is

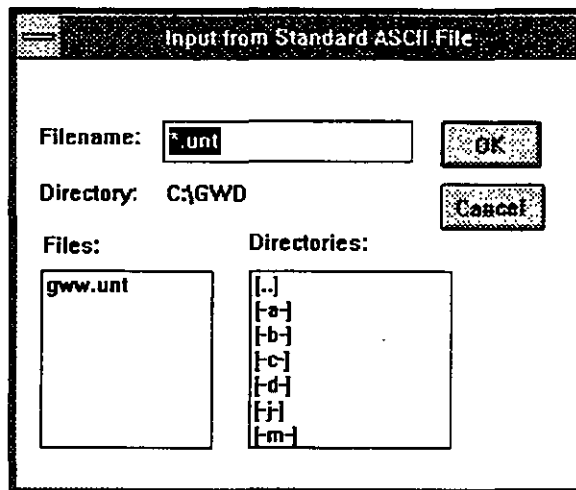

Figure 4-10

selected, you will be prompted for an output file name under which the current system of units will be saved. Option three, when selected, will search for the file GWW.UNT in the \GWW directory.

The GWW.UNT file is reproduced in Appendix D. The three columns in this file have the following meaning: unit type, unit, conversion factor.

**4.5. UNITS IN
INDIVIDUAL
APPLICATIONS**

Each application handles units that are specific to that application in its own way. Normally you may view the units currently used (using option **General Data Units**). These units can be changed within an application.

In some applications you decide on current units for data measured in the field. You may convert from metric to practical American hydrologic units, if you wish so, without affecting the general data units set.

However, be careful when changing units for length and elevation that are used in the mapping and cross section applications. The units must be consistent, otherwise you may end up by not being able to add some lines onto cross sections. This will happen if you create the data base in feet and decide to use metric system for cross sections.

5.1. GENERAL

To begin with you should know that the GWW package comprises the following applications:

- Master Data
- Chemistry: Samples
 - Chemistry: Concentration-Depth Series
 - Chemistry: Concentration-Time Series
- Pumping Tests
- Hydrographs
- Mapping
- Cross Sections
- Fence Diagrams
- Step Drawdown Tests
- Grain Size Distribution Curves
- Miscellaneous
- User Data

They are selectable from the Main menu bar under option Application as shown in Figure 5-1.

Some of procedures and routines are either exactly the same or about the same in more than one application. In this Chapter we will describe some routines and procedures which are common to more than one application, such as: (a) selection of units for a particular application, (b) selection of a working set or a working group, that is reducing a large set of data to a smaller subset; (c) setting up the printer, (d) creating random data "models" (internal files) to be used for mapping, gridding and contouring, and (e) reading from standard ASCII files and/or writing to standard ASCII files.

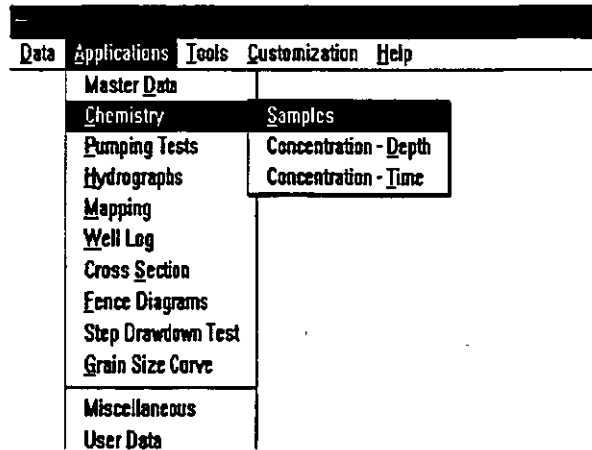

Figure 5-1

5.2. UNITS

In addition to setting up a system of units as explained in Chapter Four, each application has its own way of permitting you to select units for that particular application. Once in the application, you may select but not modify, delete, rename or add a unit or a unit type, or modify a conversion factor. This must be done using option Units from Tools on the Main menu bar.

The applications Hydrographs, Pumping Tests, Step-Drawdown tests, Chemical Concentration -Depth Series, Chemical Concentration - Time series, and Grain Size Analysis have the option General Data Units on the Data menu, as shown in Figure 5-2.

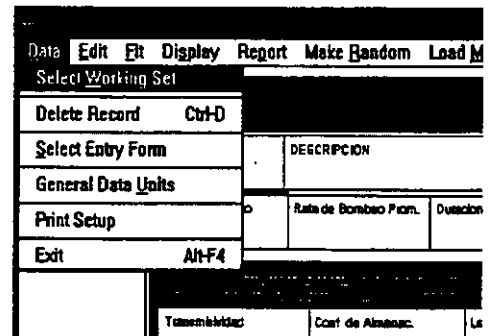

Figure 5-2

The Master Data application permits you to select units from the **Units** menu on the application's menu bar.

Depending on what you have selected to keep in your Master Data application you may select units for any entry that is identified as numerical (dimensioned) data type. In the standard case which is supplied as a default for master data structure, you may change units for coordinates (X and Y), for ground surface elevation (Z) and for elevation of the measuring point (ZM). When you select **Units** on the menu bar, the offering will be the same for whichever data entry you select to change. This is shown in Figure 5-3.

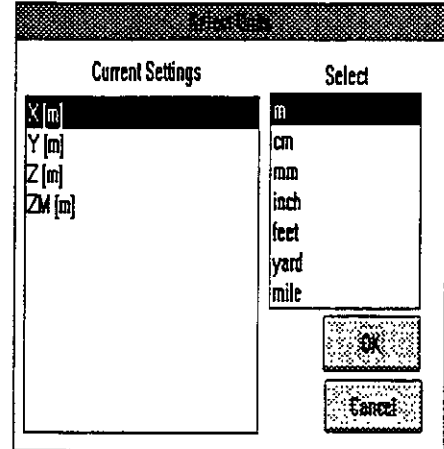

Figure 5-3

Applications Cross

Sections and Mapping have their own options for editing or modifying units. Figure 5-4 displays the menu options for cross sections.

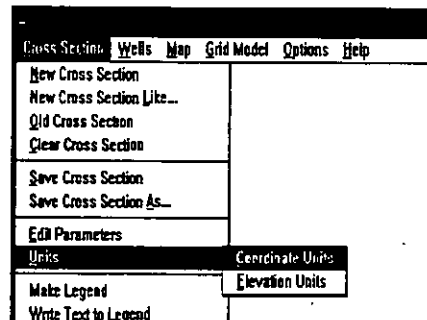

Figure 5-4

In applications Pumping Tests and Hydrographs the selection is different for general data and for measured data. In the application Hydrographs, the general data are the same as in the Master Data application (*coordinates* and *elevations*). In a pumping test the general data are *distance* between a pumping and an observation well, *transmissivity*, *standard error of fit*, and the same *coordinates* and *elevations* as in the Master Data application, as shown in Figure 5-5 for transmissivity and in Figure 5-6 for average pumping rates.

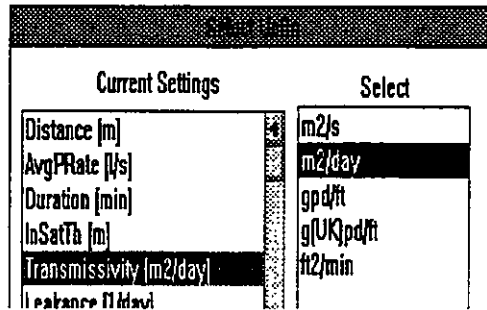

Figure 5-5

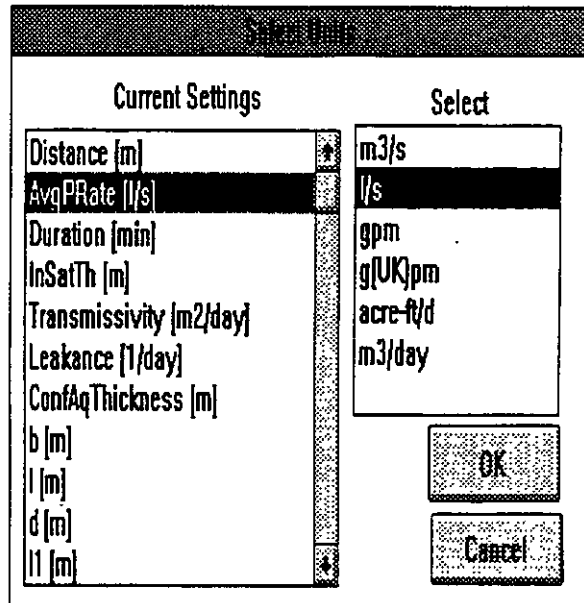

Figure 5-6

The program obtains the list of dimensioned entries from data structure files (Chapter Two), and the units from the System of Units (Chapter Four).

For the pumping test and hydrographs applications you may also want to select units for measurement or observation data, such as levels, drawdowns, time of pumping and pumping rate. These are called measurement units and the option for selecting them is located on Edit submenu as shown in Figure 5-7. For the pumping test

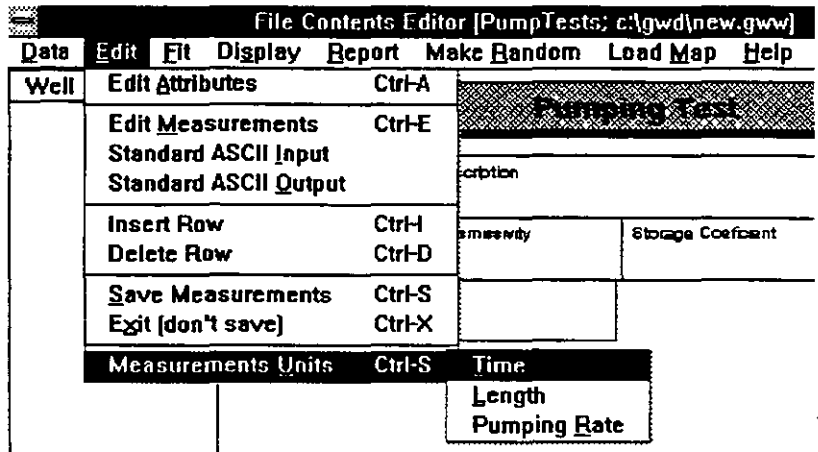

Figure 5-7

application you may select units for time, length and pumping rate, and for the hydrographs application for time and length. Figure 5-8 displays the units that may be available for pumping rate (flowrate).

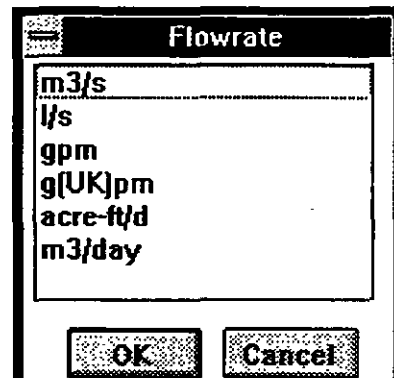

Figure 5-8



*NOTE. It is important to note that what you are doing in an application is relevant only for calculations and reporting but will not modify the system of units that you have taken either from the default file with units, GWW.UNT, or have modified and saved using the option **Units** from the **Tools** submenu.*

5.3. SELECTION OF WELLS OR SAMPLES OR REDUCTION OF A LARGE DATA SET TO A SMALLER SUBSET

This is one of the most important and attractive operations in the GWW system. Being programmed to run under Windows and relying on Windows resources, a large pool of memory and huge storage capacity, and especially counting on the processor speed of 66 MHz and above, the GWW package has been programmed for large data bases. Under "large" we mean hundreds or even thousands of wells or water samples. (If you intend to run GWW on a 25MHz 386SX PC, you better limit your data base to 100 wells.)

Working with a large set of wells may become inefficient after a certain number. Yet very often we want to pay our attention to an area, an aquifer, a parameter, or to certain wells that differ in something from the rest. For example, we may have 500 wells in our data base, but we wish to create a map showing locations of wells in which one specific chemical constituents has been identified. In addition, we wish to create a contour map of that constituent using only wells in which it was detected above a certain limit. In other words, we want to eliminate from the display all wells in which this constituent is less than the prescribed minimum.

How we do it?

We have several ways for filtering the data base and searching for samples/wells that satisfy a defined criterion. These are discussed one by one below.

- 5.3.1. **Select Condition** The applications Master Data, Chemistry, Pumping Tests, Hydrographs, Well Logs and Lithology, and Step Drawdown Pumping Tests have all **Select Working Set**

option on the **Data** submenu. An example from the Master Data menu is shown in Figure 5-9. In the example

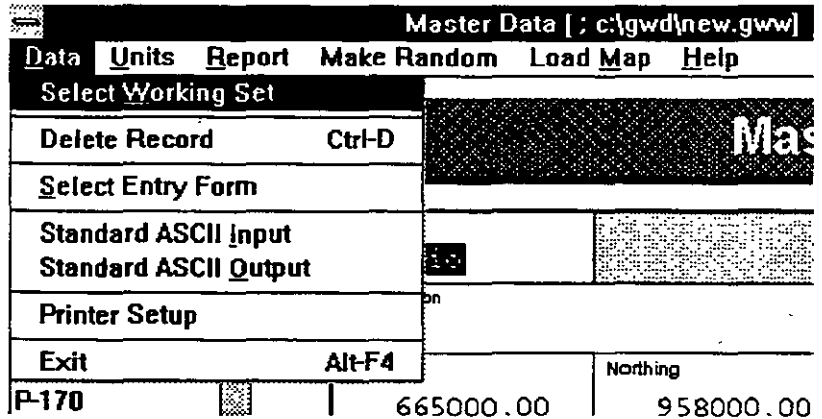

Figure 5-9

shown the data base contains more than one hundred wells. Identification of wells starts with either letter P (for 'Parcelamiento' in Spanish), or with letter S (for 'Sistema de Riego Rio Guarico', or, translated to English 'River Guarico Irrigation System'). The selection criterion built into the GWW permits you to use the identification name, or any other information in the data base, whether it is a character or a numerical value, for reducing the large set of wells to a smaller subset.

The option **Select Working Set** is interpreted as follows: send all other wells or samples into background, display only wells and samples that will be selected, and keep working only on this reduced set.

When you click on **Select Working Set** a box similar to the one shown in Figure 5-10 will appear. The difference will be in that all wells would be shown as "selected items". If, for example, you wish to reduce the set to only wells belonging to the irrigation system, which are identified with the name SRRG-xx, where xx is the sequential number of a well, you should do the following.

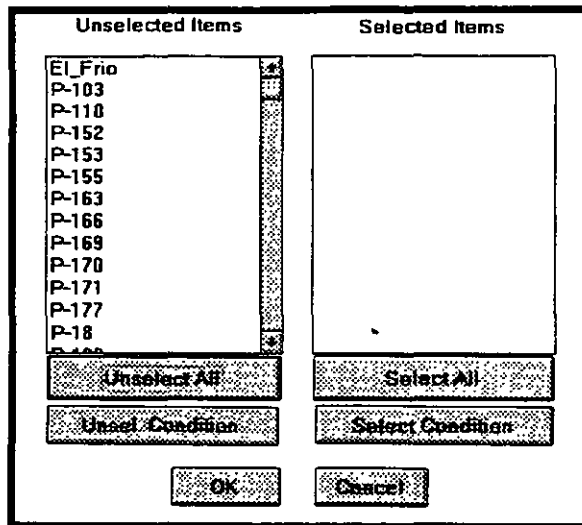

Figure 5-10

1. Click on **Unselect All**. The 'Selected Items' window will be without any well. All wells are moved to the left window, and the display looks as shown in Figure 5-10.
2. Click on **Select Condition**. The dialogue box as shown in Figure 5-11 will appear offering you to select a variable to use as a 'selection condition'. The variables are all data that make a part of your Master data portion of the data base.
3. Click on the arrow next to the Well Ident field, and see the list of parameters popping down. If there are more parameters than the size of the window there will be a slide bar on the right side. This is shown in Figure 5-12.

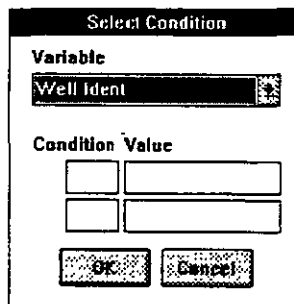

Figure 5-11

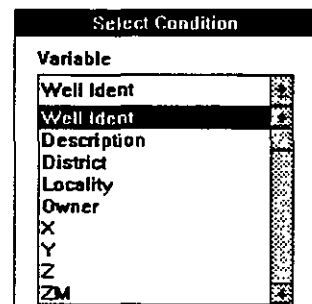

Figure 5-12

4. Click on **Well Ident**, which was suggested by the program as a default, and type under the **Condition Value** the equal sign in the left box and the combination **S*** in the right box. The program permits you to use logical operators =, >, < in the left box, and wildcards (* and ?) in the right box. In the case shown in Figure 5-13, the interpretation is as follows. Select only wells identified with a well name starting with letter S regardless of what follows after the first letter. You could have used the second character in the identification name, the third, or any, using wildcard symbols for the characters that you do not care.

Figure 5-13

5. Select **OK**. Notice in Figure 5-14 the 'Selected Items'

Figure 5-14

window filled with identification names starting with the letter S.

6. Select **OK**. You will be back in the Master Data main menu, but the list of wells, which is normally displayed on the left side, will contain only wells start-

ing with the letter S, as shown in Figure 5-15. In addition, the number of wells, displayed on top of the list, will reflect the altered working set content.

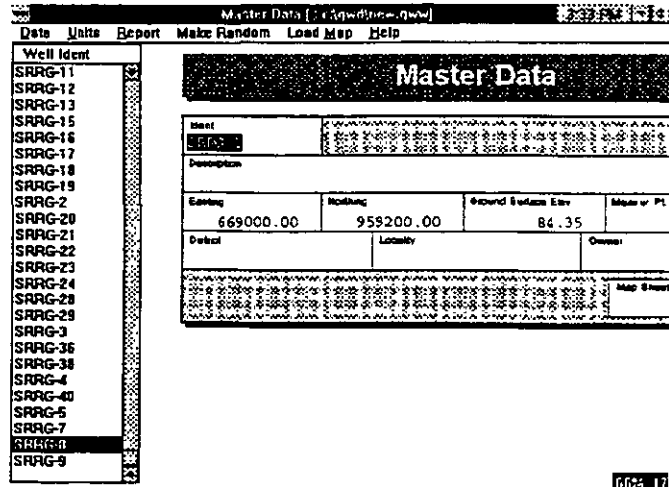

Figure 5-15

You may use a double selection condition to select wells within a certain range. For example, if you wish to reduce a large set of wells to a smaller subset being located within a certain area, you may select X coordinate as the selection criterion, and type \geq signs in the upper left box, followed by the minimum X coordinate, and type \leq signs in the lower left box, followed by the maximum X coordinate. Only the wells in which the X coordinate matches this condition will be selected. You may repeat the selection procedure on this already reduced set, selecting in the same way the Y coordinate for the selection condition.

However, there is a better way to select wells within a certain area. This is explained next.

5.3.2. Selection from a Map

You will notice that in all but Mapping and Cross section applications there is an option **Load Map** or **Map** on the menu bar. This option is used to select wells directly from a map. You create these maps in the Mapping application, placing either all wells or already reduced set

or selected wells to emphasize thematic purpose of maps.

When you select Load Map option the dialogue box as shown in Figure 5-16 will be displayed. The lower field lists all currently available maps. Remember that maps are objects in the GWW system, and each is associated with a name. In the case displayed in Figure 5-16 there is only one map, named basic-log, which contains locations and names of wells which may have known lithology or well log. You may either type the map name (exactly as it is shown) or double click with the mouse on the map name. The map will be displayed as shown in Figure 5-17.

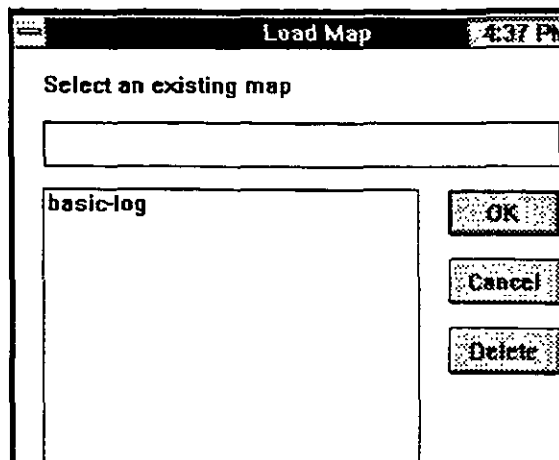

Figure 5-16

The map will be displayed as shown in Figure 5-17.

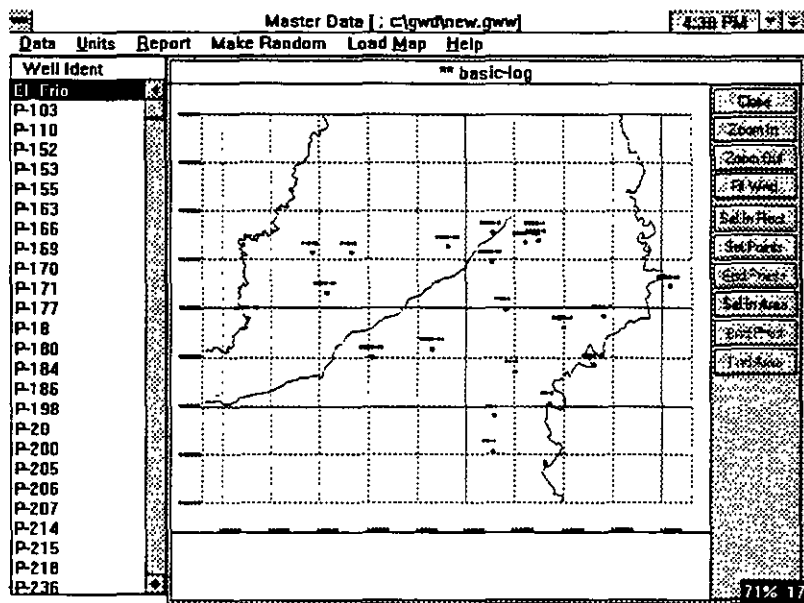

Figure 5-17

Notice various buttons on the right side. Their meaning is as follows:

- Close** Removes the map from the display.
- Zoom In** Permits you to enlarge a portion of the map.
- Zoom Out** Returns the display to its normal view.
- Fit Wnd.** Redraws the map to fit the entire window.
- Sel.In.Rect.** Permits you to select wells within a rectangle.
- Sel.Points** Permits you to select well points one by one.
- End Points** Ends selection of wells point by point.
- Sel.In Area** Permits you to select wells with free hand, making a closed contour around wells.
- End Point** Refers to selection of an area and is used to connect the last point with the first point of a line making an area.
- End Area** After the line delineating an area is closed, 'End Area' command selects all wells within this area.

One example using a rectangle is displayed in Figures 5-18 and 5-19. It is important to remember that prior to

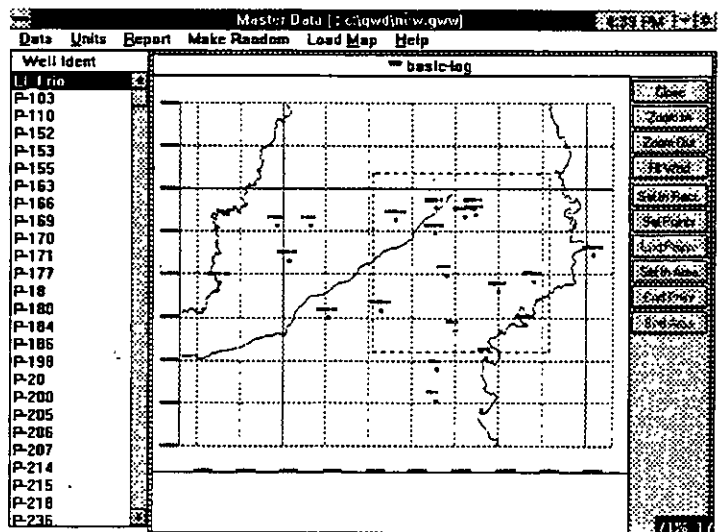

Figure 5-18

selecting wells using a map, all wells should be unselected so that only the really desired wells will make the data set. In Figure 5-18 a rectangle is drawn by dragging the mouse from one point to another. The wells located within this rectangle are displayed on the left side of Figure 5-19.

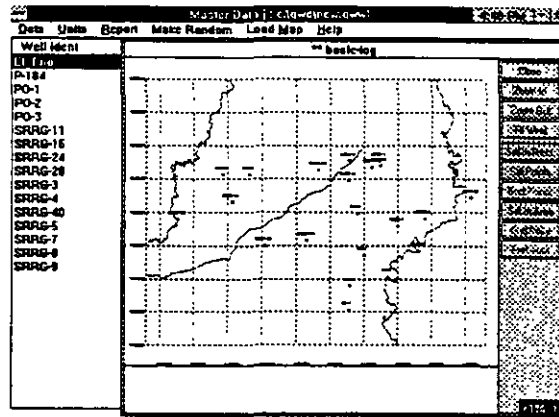

Figure 5-19

Figures 5-20 and 5-21 display the selection process using free hand drawing of an area around wells to be selected. In this case the following steps are made.

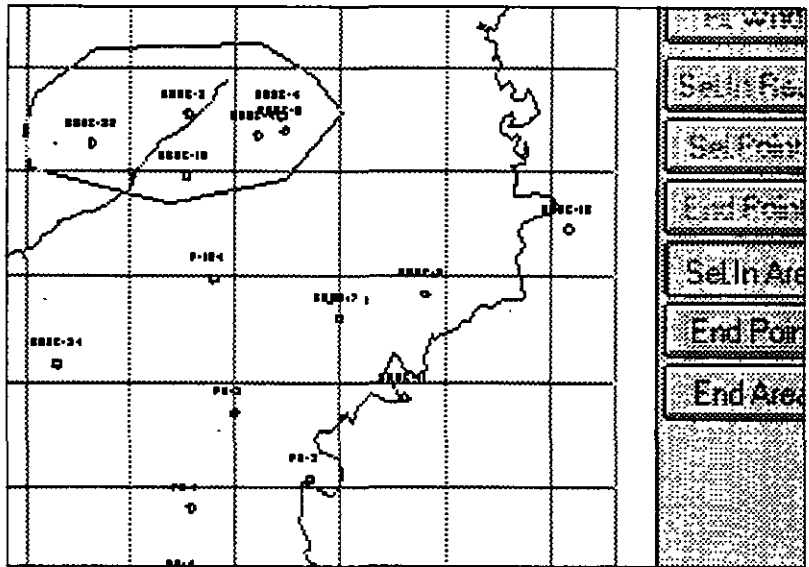

Figure 5-20

1. From the **Data** menu bar option **Select Working Set** is activated.
2. In the selection dialogue box all wells are unselected.
3. **Load Map** option is selected.
4. The map named 'BASIC-LOG' is transferred into the upper window and selected by clicking **OK**. The display is as shown in Figure 5-20 without the contoured area.
5. **Sel.In Area** button is activated.
6. Using free hand drawing with the mouse, a line is made with several points around wells to be selected. The final point is close to the initial point.
7. **End Point** (second from the bottom) is activated.
8. **End Area** button is activated.

The display is now as shown in Figure 5-21. You may zoom in the map to make your selection more precise.

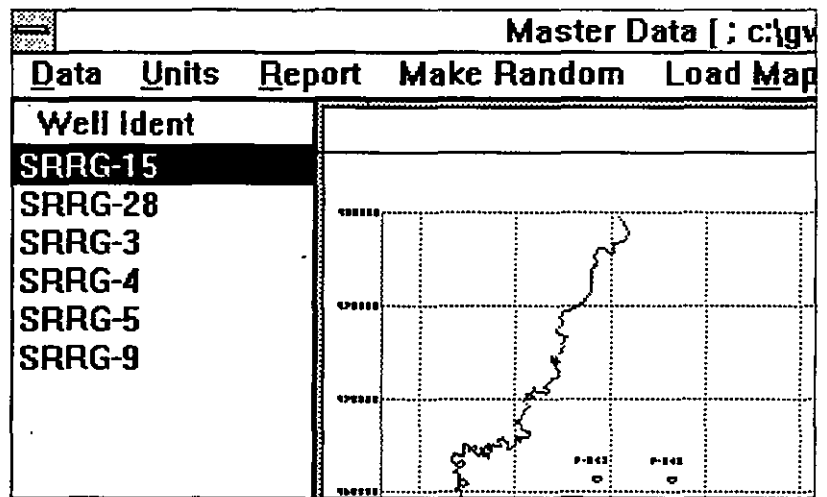

Figure 5-21

5.3.3. Selection of Wells One by One

You may select wells one by one, without using a map, in the following way.

1. Activate option **Select Working Set** as before.
2. Unselect all wells.
3. Click with mouse on a well on the left side (unselected) to move it to the select window.
4. Repeat the same operation with other wells that you want to work with.

This way is recommended only if you wish to work with a very small number of wells, for example, to create a lithologic cross section with full control over what you want to place on the cross section.

5.3.4. Working Group

The concept of a Working Group which is used in Chemistry and Cross Sections applications differs from the Working Set concept in the following. A Working Group is a subset of a Working Set. Wells which will be shown on a group diagram or display make the group. For example, you may have a large data base with hundred of wells. You may have reduced this data base to a smaller Working Set of wells belonging to a particular area. Say that your Working Set comprises 40 wells. You wish to present on a Piper diagram only 10 wells. You will create a Working Group to be composed of only these 10 wells.

Or, another example. You may have the same 40 wells with known lithology. You wish to place 6 wells on a lithologic cross section. You will create a working group with these 6 wells that will be displayed on the cross section. In both cases other wells making the working set will be still listed on the left side of the screen.

You select wells for a working group in exactly the same way as explained above. There is only one minor difference in the case of Chemistry application. There, the option on the menu bar is Map, followed by two other options: **Make Working Set** and **Make Working Group**.

Note that group display diagrams (Piper, Wilcox, Schoeller) will not display what they are supposed to display unless a working group has been created.

5.4. SETTING UP PRINTER

Selection of printers and attributes related to printing is normally a Windows operation. For this you go to **Main Windows** menu, select **Control Panel**, then **Printers**, and configure the printer you wish to use.

In the GWW system you have an option **Printer Setup** in every application. It is used to change the orientation of printout, portrait (vertical) or landscape (horizontal), the printing medium, the quality of print, number of copies, colors for a color printer, and many more. Actually, the GWW system brings a printer driver that had been configured as a default printer in Windows' Control Panel. Remember that you cannot change from within a GWW application a default printer and replace it with another currently installed printer. If you wish to do so, you must either exit completely from the GWW, or better, stay within the application but temporary exit by using the combination CTRL+ESC key to go to the task assignment, select **Program Manager**, then select **Main**, and **Control Panel**, then **Printers**. Change the default printer, close **Control Panel** and return to the application by activating once again the task assignment list (CTRL+ESC).

Printer Setup is an option located on the **Data** submenu of every application. The example shown in Figure 5-22 is from the Master Data

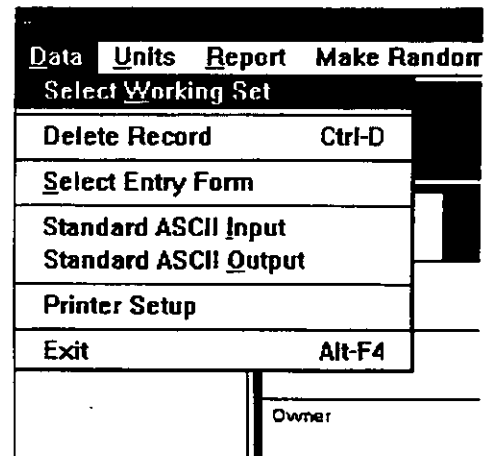
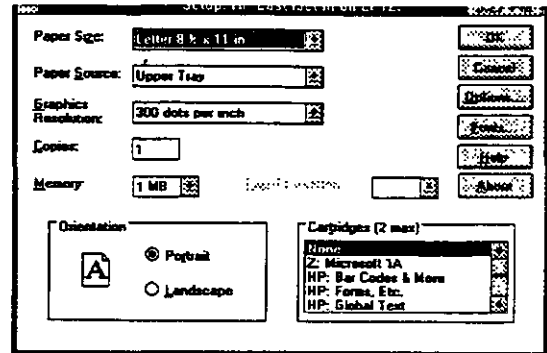

Figure 5-22

menu. When selected the screen may look like the display in Figure 5-23. This is the printer driver's menu for the Hewlett Packard Laserjet III. You can access the same driver's menu from the Windows' Control Panel.

Figure 5-23



5.5. READING FROM STANDARD ASCII FILE OR WRITING TO STANDARD ASCII FILE

ASCII or text files are prepared with a text editor or word processor and saved unformatted. This type of file contains only the printable ASCII characters and the few control codes needed for minimal formatting, such as carriage returns and linefeeds.

ASCII files in the GWW system serve in two ways:

1. To save most of the information from the GWW data base internal format in separate files that can be edited, modified, and input back into the GWW system.
2. To provide external connection with other data base formats such as dBase IV, FoxPro, Clipper, etc. There is no direct import of other data base formats into the GWW system. However, every data base package can, if programmed, export information in ASCII file format. This information, modified to be compatible, can then be imported into the GWW system.

What can you save from the GWW internal files and structures in an ASCII output file?

Here is a list of information that can be taken out of the GWW system or that can be directly written from within the GWW into ASCII files.

1. Data structures, such as Master Data structure file, which is reproduced in Appendix B.
2. Entry forms, such as Chemistry application entry form, which is also reproduced in Appendix C.
3. Reporting forms, such as Well Log reporting form, which is reproduced in Appendix C.
4. Master data for all wells that make working set. When you select to read the data from a standard ASCII input file the dialogue box as shown in Figure 5-24 will open prompting you for the name of the file. The

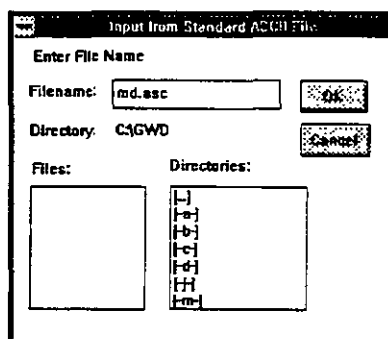

Figure 5-24

data to a standard ASCII file. Again you will be prompted for the file name. After the transfer is completed there will be a message displayed showing how many wells have been written to the ASCII output file. This should be a good practice to back up the information entered into the GWW system by creating output ASCII files, which then can be used as input files in the case something goes wrong.

same kind of the dialogue box will be displayed, as shown in Figure 5-25, when you decide to write master

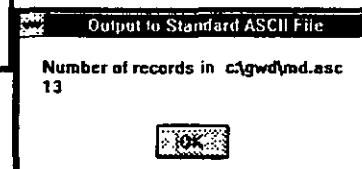

Figure 5-25

5. Chemical data for all wells that make working set. Comments that apply for master data are valid here too. Every piece of information referring to the chemical part of the data base will be copied to the ASCII file. Constituents will be transferred in parts per million (ppm) or equivalents per million (epm) depending on in which units they were displayed when you have selected to copy them to the ASCII file.
6. Water level measurements data will be saved as one ASCII file for all wells. This file will contain all general data identifying wells and all measurements. The format of such a file is very strict, to make it consistent with the output format of hydrograph data files from the United Nations Ground Water Software Version One. You must not modify this format if you wish the GWW software to correctly input the information.
7. Pumping test data will be saved on the file-for-single-test basis. This is to say that each pumping test will be saved in its own data file. Actually the file will contain three columns, one with time, another with drawdown or level measurements, and the third one with pumping rates. An example of a pumping test data file is also presented in Appendix D.
8. Well log data will be saved in an ASCII file on the file-for-single-well basis, that is one data file for each well. Only lithological data, including depth intervals, codes and description of lithologic units will be saved. Again, the output ASCII file format for lithology is made consistent with the Version One of the U.N. Ground Water software.
9. In Well Log application there are two more information files that can be saved as ASCII files: codes, symbols and textual description of materials filling annular space of a well, see Figure 5-26, and codes, symbols, and default description of lithologic units a well had been drilled through. These are specific information files and will be discussed in Chapter 10. Well Logs and Lithology.
10. In Mapping application almost every component of a map can be saved as an ASCII file. For example, you

Well Log [c:\gwd\new.gww]					
Construction		Report	Lith. Units	Load Map	Make
Annulus					
Hole					
Casing					
Screen					
Constr. Units		11			
Annulus Materials		Edit			
999.00	949000.00	Standard ASCII Input		79	
Concrete Block		Standard ASCII Output			
Concrete Block		Scales			
Dy	Height	Vertical	Horizontal		

Figure 5-26

may create a line by directly digitizing on the screen and save this line as an ASCII file. Or you may use your digitizing tablet, create a line and save it in an ASCII file, which, then, may be used to input the information into the GWW system. More than one line can be saved as one ASCII file. Each line is terminated with /* characters on a separate file line.

In such files the format of data input is free; entries are separated by one or more spaces or a comma followed by a space. You may type the information anywhere on the line following the above convention.

You may save an entire grid in an ASCII file, using the option on the grid submenu as shown in Figure 5-27. The grid, which is actually a gridded model, associates a numeric value with every node of the model network. This value can be land surface elevation for the grid model of the ground surface, a water level elevation, total dissolved solids, a content of a constituent, or anything from your data base that has a numeric value associated with the location of a point (that is, with X and Y coordinates). Such files can be used as input data files to modeling software such as MODFLOW, U.N. GWMOD, etc.

You may save areas and random points. This last data file is the basis for creating contour maps. One example of a random data file is presented in Appendix D.

As before, this file is written in the free format. The columns have the following meaning: X coordinate, Y coordinate, ground surface elevation, and well identification.

The attractive possibility is to create an ASCII file with four such columns of numbers and characters, and input it into the GWW for further processing: creating a map, making contours, adding color intervals to the map, and printing the map.

11. A text file with the text to appear on a map can also be saved as an ASCII file, Figure 5-28. The

text will be identified with all attributes required for fonts, colors, alignment, angle of plotting, etc.

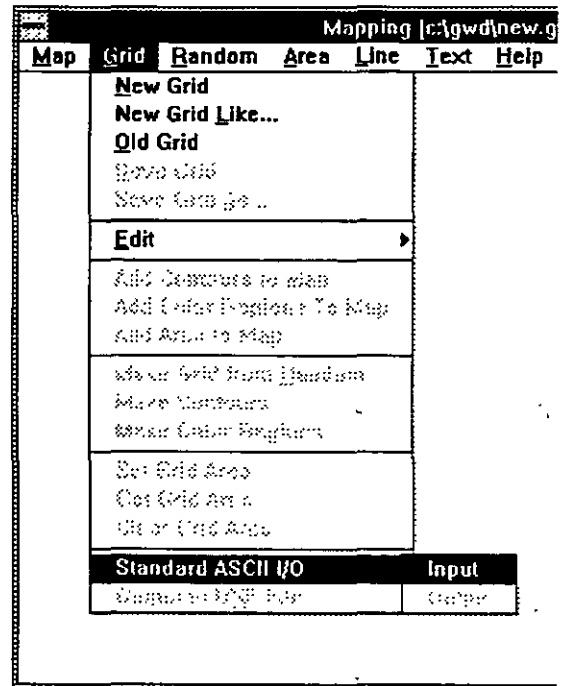

Figure 5-27

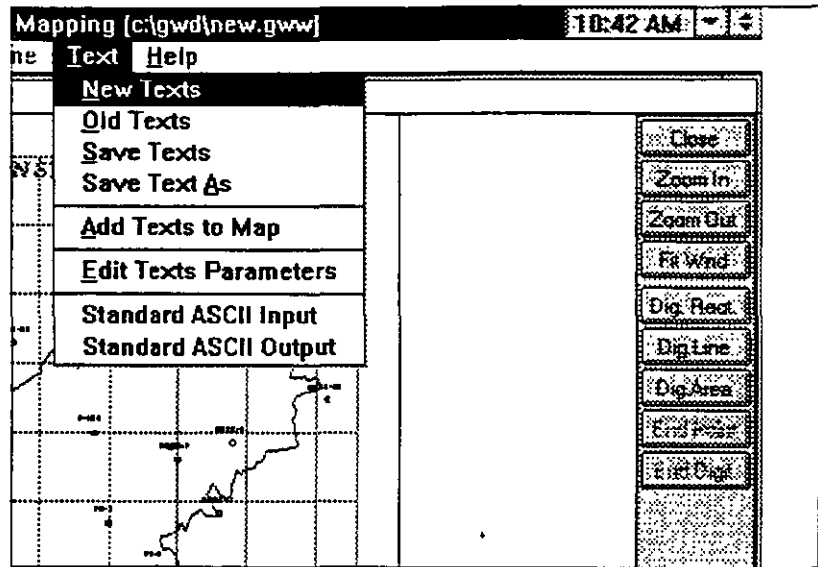

Figure 5-28

Additional Notes on ASCII Files

- (a) The format of ASCII input and ASCII output files is identical. In other words, what you save as an ASCII output file from within the GWW system, you may use as an ASCII input file to the same or another data base created with the GWW program.
- (b) You may edit ASCII files created by the GWW program, but in some files it is important to keep the same data format, while in other files it is not.
- (c) When the GWW program saves data in an ASCII file, it may add underscore characters to fill some gaps in the information. It is important to keep these characters in the files in order for the GWW to read them correctly.
- (d) Master data and Chemistry applications will create a very specific first line in the ASCII output file. They will list all entries according to field names from the data structure and place these field names within angular brackets. The program expects to find these same entries in numeric form in the lines that follow.

With this convention, the program interprets the numeric data entry and relates it to well identification and chemical constituents. You may edit this just like any other ASCII file, but exercise some caution.

5.6. CREATING RANDOM MODELS

The Random Model is an option which is built into every application of the GWW package and which prepares data for creating contour maps. You may create a random model, and consequently a contour map, of every numeric parameter in the data base which is associated with the location of wells, that is with X and Y coordinates.

The option **Make Random** is located on the menu bar in every application. When invoked, a dialogue box will open offering you to choose from the list of space-distributed parameters. The list will contain only parameters specified for this application, plus parameters from master data application. Thus if the **Make Random** option is invoked from the Chemistry application, the list will contain all chemical parameters, total dissolved solids, hardness, alkalinity, conductivity, even pH, plus X, Y, Z and eventually Zm (elevation of measuring point).

This is a very attractive option, since in using it you may create a contour map of every parameter of interest. For example, if in the Chemistry application you have entered toluene as a data base item you may create a toluene content contour map, showing toluene in ppm or in epm. Of course this option, coupled with select **Working Set** option described earlier, makes possible the creation of a location map showing only wells in which toluene has been detected and add toluene content contours to such a map.

The **Make Random** option is different in the Hydrographs application in the sense that there you are prompted for a certain date for which you wish water level measurements to be taken (or interpolated if miss-

ing on that date). Once you supply the date (month, day, year) the rest is the same as in other parts of the program.

One example is shown in Figures 5-29 and 5-30. When **Make Random** option is activated from the Chemistry application, the display list is as shown in Figure 5-29. Notice the side bar since the list is too long to fill one screen length. When, in this example, the TDS (total dissolved solids) parameter is selected, the program scans all wells and samples, reads X and Y coordinates and prompts you for the random point file name as shown in Figure 5-30. By default you will be offered the name of selected parameter which you may confirm or change.

The random point file is an internal file which is used then in the Mapping application for creating various thematic maps.

There, its content may be saved as an ASCII file. As discussed earlier in this Chapter, such an ASCII file will have four columns, with X and Y coordinates in the first two columns, the TDS values in the third, and well identification name in the fourth column.

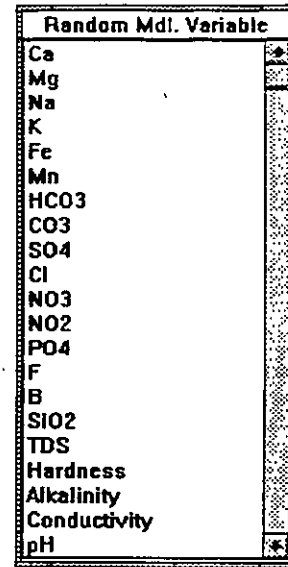

Figure 5-29

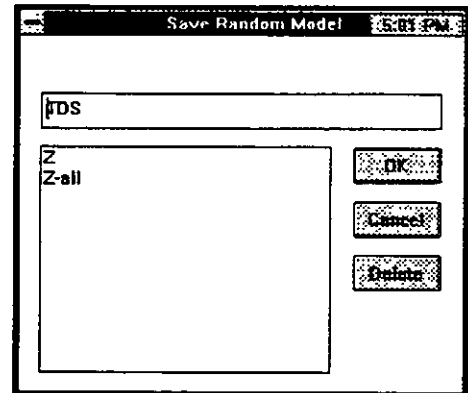

Figure 5-30

**5.7. EDITING A
TABLE AND
ATTEMPTING TO
ESCAPE WITHOUT
COMPLETING
EDITING**

In several applications you may be editing input data in a table. These applications are: pumping test, step-draw-down test, grain size curve, and hydrographs. If you open a table with the measurement data and attempt to activate another option, such as display or fit while still in the editing mode, there will be an error or warning message as shown in Figure 5-31. You may then either cancel this attempted operation, save data before the operation is executed, or exit the table without saving the newly edited data.

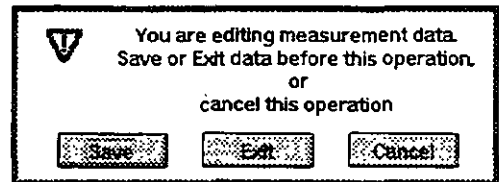

Figure 5-31

This page intentionally left blank.

6.1. GENERAL

The Master Data application is the heart of the whole system. Every well, entered from any application, ends up in the Master Data application. It serves a kind of housekeeping for the information that is shared among applications.

The Master Data application is intended for entering general information for wells, water points, and/or water samples. This information is generally the following:

- Well identification, which can be any combination of characters and numbers, up to the size specified by you (or the program's default) in the file structure tool.
- X and Y coordinates that uniquely locate a well, a water point and/or a sample.
- Z coordinate, or ground surface elevation, or an elevation of any other point on the well that has been surveyed, measured or taken from a map.
- Coordinate of water level measuring point such as top of casing, top of concrete block, etc.
- Name or location, other names for a well, and the like.
- State, region, province, country, or a county; one, more than one, or all of these.
- Owner of well.
- Year of construction.
- Relationship of the well to: river basin, hydrologic unit, aquifer system, municipal water supply scheme, landfill monitoring system, irrigation system, etc.

- Use of well.
- Equipment installed.
- Number of the topographic map to which the well belongs.

One especially convenient entry would be one character code (Yes or No) specifying additional information about this well. For example, if you want to have a quick overview of all wells in the data base that have a water level monitoring record, you may add a field into the Master data structure which will prompt you to enter either Y (for Yes) or N (for No). The name of the field may be as follows: *Water Level Data Available?* This code can then be used to reduce the data base to a working set of wells for which a water level record exists. Thus without switching to the Hydrographs application you may create a map showing locations and names of all water level recording wells.

Similarly, you may want to have a coded field for lithology, chemistry, pumping tests, etc.

6.2. RELATIONSHIP BETWEEN MASTER DATA AND OTHER APPLICATIONS

Depending on what you have entered on Entry Forms for other applications, some of the information from the Master Data part of the data base will be copied to other application's entry forms. For example, you may have selected to have on Entry Form for Chemistry the coordinates and location/description of wells. If this information is typed in the Master Data application, the same information will be directly copied to Chemistry Entry Form as soon as you type the Well Identification name within the Chemistry application of a well that exists in the Master Data application.

Conversely, if you are satisfied with entering general information for a well consisting only of its coordinates and elevations, leaving the field on its location, local name, or description blank, you may enter this informa-

tion under the Chemistry application and it will be copied to the Master Data application next time you work with it.

You may begin inputting data in any application, not necessarily in the Master Data application. When you have finished, you may switch to the Master Data and notice that all wells that you entered in the other application will be found in the Master Data application as well. This is the **relational** aspect of the data base.

6.3. ENTERING INFORMATION

The screen display of the Master Data application may look as shown in Figure 6-1. The left window contains the list of all wells that are currently in the data base.

Master Data			
Well: El Frio			
Description: Municipal Water Supply well in El Frio			
Easting: 665000.00	Northing: 958000.00	Ground Surface Elev: 83.31	Measur Pl. Elev: 83.31
District: El Frio	Locality: City	Owner: MARNR	
			Map Sheet No: HN-2254

Figure 6-1

Please note, however, that only the wells that you have selected as the Working Set will be listed. The program remembers what you left last time you worked with the data base. If you closed the data base working with a

reduced Working Set, that is what you will find next time you open the data base.

Most of the screen is occupied with the Master Data Entry Form. As you type the information, you can move from one field to another using either TAB key or ENTER. Remember that information is not saved unless you press TAB or ENTER. One entire well is saved only if you answer all prompts (fields) on the Form, or if you press the PAGE DOWN key. As soon as you press the PAGE DOWN key, you will notice that the identification number of the well will appear in the well list window.

To move forward in the form use the TAB key. To move backward use the SHIFT+TAB key combination. To move from one well to another use PAGEUP or PAGEDOWN. Alternatively to finish entering information for a well, press PAGEDOWN or PAGEUP. One well on the list of wells window becomes highlighted. Now you may use arrow keys to move up or down. To select a well you may always click with the mouse on its name in the list.

6.4. OPTIONS ON THE MENU BAR

6.4.1. Data Submenu

The following options are available on the Data submenu:

Select Working Set. This is explained in Chapter 5, section 5.3.

Delete Record. This is used to delete an entire record from the data base. However, deleting a well from the Master Data application will not delete this well from the data base, if the same well is used in some other application. Remember this is a relational data base. The information about the well is still written to another application's base and transferred to the Master Data application for housekeeping. If you wish to eliminate a well completely the best way is to delete it from applica-

tions other than the Master Data. When it disappears from all applications, only then you should delete it from the Master Data.

Select Entry Form. You may have more than one Entry Form in your data base. Prior to inputting data you should select an Entry Form. When you activate this option a dialogue box with all available entry form names will be displayed for you to choose from.

Standard ASCII Input. This is explained in Chapter 5, section 5.5. It is used to import data from other programs, such as dBase IV, provided they are saved as a standard ASCII file and that they follow the GWW convention of input. Using this option you may enter many wells at once without using the Entry Form.

Standard ASCII Output. This is also explained in Chapter 5, section 5.5. It is mainly used to back up your data base.

Printer Setup. This is explained in Chapter 5, section 5.4. It is a standard Windows routine which displays the dialogue box of the printer driver that you have selected to be the default printer in Control Panel of the Windows Main Menu.

Exit. Selecting this option or pressing ALT+F4 will terminate the work in the Master Data application and return you to the GWW main menu.

6.4.2. Units

Units are discussed in Chapter 5, section 5.2.

6.4.3. Report

The following options are available on the Data sub-menu:

- **Print Report**
- **Select Table Form**
- **Select Record Form**

There is a line separating the **Print Report** option from the rest. In the Master Data application, and in most other applications, you may want to print the information for each well on separate pages, or group all the information for all the wells on one or more pages. The first option would be printing a record, and the second printing a table.

Grouped information may be printed in a table like the one shown in Figure 6-2. An individual record for a well may be printed in a record form as shown in Figure 6-3. Both of these forms can be designed using **Tools** on the Main menu bar, and selecting **Report Forms Editor** as

The screenshot shows a window titled "Form Editor [c:\gwd\new.gww]" with a menu bar containing "Form", "New Field", "Attributes", "Options", and "Help". The main content area is titled "Coordinates" and contains a table with the following structure:

Well General Data - Coordinates				
Well Ident	X	Y	Z	ZM

At the bottom right of the window, there is a label "Type:".

Figure 6-2

explained in Chapter 3.

The normal procedure in printing a report would be to choose between one of options: **Select Table Form** or **Select Record Form**, and then select **Print Report**. For example the report as displayed in Figure 6-2 was printed using the following sequence:

1. **Report.**

The screenshot shows a software window titled 'Form Editor [c:\gww\new.gww]'. The menu bar includes 'Form', 'New Field', 'Attributes', 'Options', and 'Help'. The main window is titled 'Standard' and contains a form titled 'Master Data'. The form has the following fields:

Ident			
Description			
Easting	Northing	Ground Surface Elev	Measur. Pt. Elev
District	Locality	Owner	
			Map Sheet No.

The status bar at the bottom right of the window displays '6:57 AM'.

Figure 6-3

2. **Select Table Form.** The dialogue box opened suggesting only one reporting form with the default name Coordinates (this is a pre-programmed part of the GWW.000 template).
3. The name **Coordinates** was double clicked.
4. **Print Report** option was then selected.

6.4.4. Make Random

This option is discussed in Chapter 5, section 5.6. It is one of the most important options provided by the GWW system. Normally you would want to produce a location map showing all wells contained in the data base. To do this, activate the **Make Random** option, select Z, the land surface coordinate, if available for all wells, or any other distributed numerical parameter that may be known for all wells (such as X or Y coordinate), and create a random model. (*Random Model* is a misnomer in this early stage of the discussion. Using this option you only create a file which contains random points and their X and Y coordinates, well identification and a space-de-

pendent numerical parameter. Only in the Mapping application you will create a gridded model from these random points.)

6.4.5. Load Map

This option, which is discussed in Chapter 5, subsection 5.3.2, is also one of the most important features of the GWW system. It permits you to reduce a large set of wells to a smaller set by directly selecting from the map.

6.4.6. Help

This is a context-sensitive help which contains most of the explanations, procedures and routines that are applicable to the Master Data application.



NOTE. Carefully evaluate what you will store in the Master Data application. When you backup any application, say chemistry, all data entries coming from that application plus from the Master Data application will be copied to an ASCII file. The ASCII backup for chemistry may become unnecessarily "loaded" with information from the Master Data application if you keep in the latter too many entries.

On the other hand, well logs application will not backup data entries which have not been foreseen by the programmer. For example, even if you prepare data entry fields such as elevation of a stratigraphic unit, or thickness of another unit, etc., the option Write to STD ASCII File will not copy this information to an ASCII file. If this information is maintained in the Master Data application, it will be backed up in and ASCII file.

6.5. WARNING

Try to keep the number of field entries within the Master Application to a minimum. This is because all Master entries will be copied to every other application's ASCII backup file. For example, backing up the Chemistry, you will copy not only cations and anions, and all other chemical constituents, but also all Master data.

7.1. GENERAL

In the Chemistry application you can do the following:

1. Create the chemical portion of the Ground Water Information System (GWIS).
2. Display on the screen the following diagrams: STIFF, PIPER, WILCOX and SCHOELLER.
3. Report chemical data in tables and graphs.
4. Add a location map to your reports.
5. Prepare data for contouring, create internal files with random points to be used in the Mapping application for gridding and contouring.

**7.2. MAIN MENU
BAR AND MAJOR
OPTIONS**

The main menu bar for the Chemistry application is shown in Figure 7-1. The screen is composed of three parts:

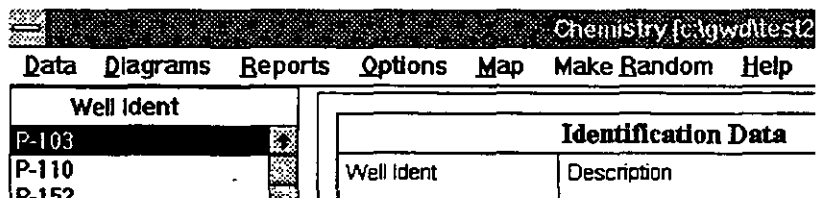

Figure 7-1

1. Menu bar with major options.
2. Well Identification window on the left, with the list of all wells/samples.

3. Entry Form for data input or editing.

The list of wells is enlarged in Figure 7-2. You may move and resize this window using Windows option for moving and resizing windows. With a large number of samples in the data base you may need to use the side slide bar to select a sample of interest.

Well Ident
P-110
P-152
P-153
P-155
P-163
P-166
P-169
P-170
P-171
P-177
P-18
P-180
P-186
P-198
P-20
P-200
P-205
P-206
P-207
P-214
P-215
P-218
P-236
P-248
P-502
P-503

Figure 7-2

The Entry Form is a default form prepared by the programmer. You may select one of your own forms with constituents other than the ones shown in

Identification Data				
Well Ident P-110	Description Production Well in Lot 110			PPM
Input Data				
Ca 13.23	Mg 20.30	Na 19.77	K 1.17	Fe
Mn	HCO3 131.79	CO3 24.30	SO4 0.05	Cl 4.25
NO3	NO2	PO4	F	B
SiO2	TDS 218.00	Hardness	Alkalinity	Conductivity 270.00
pH 8.30	Computed Data			
SAR 0.7968	Carbons 3.22	Anions 3.09	Balance Error % 4.09	

Figure 7-3

Figure 7-3. The Entry Form is also a window. You may move this window and resize it if you wish to place it on a more convenient place on the screen.



Note. By default, the Entry Form is set to accept data as parts per million (ppm). If you prefer to input epm go to Options first and click on Show EPM Values.

7.3. DATA SUBMENU

Selecting the option DATA from the menu bar will bring the pop-down sub-menu as shown in Figure 7-4. By now you should know the function and use of each of these commands. Most of it was explained in Chapter 5.

Data	Diagrams	Reports	Options
Make Data Group			
Select Working Set			
Select Entry Form			
Delete Record			Ctrl-D
Standard ASCII Input			
Standard ASCII Output			
Old to Std. ASCII Conversion			
Printer Setup			
Exit			Alt-F4

Figure 7-4

The only command that has not been mentioned is **Old to Std. ASCII Conversion**. This is a routine which converts the chemical data base created using the United Nations Ground Water Software package (UN/GW, or Version One of the U.N. Ground Water software). With this option, numerous chemical data bases created with Version One can easily be transferred into the GWW software.

You should be careful in selecting this option. It works in conjunction with the option Standard ASCII Input. First, you should convert from your old UN/GW data base into an ASCII file using Old to Std. ASCII Conversion,

then you should read this ASCII file using Standard ASCII Input. However, remember that chemical data may come as parts per million (ppm) or equivalents per million (epm). On the menu bar of the Chemistry application you will notice Options next to Reports. There you must select option Show EPM Values since the option Old to Std. ASCII Conversion will always create an ASCII file with constituents in epm.

7.4. DIAGRAMS

As shown in Figure 7-5, the Chemistry application currently has the following diagrams:

- Piper Diagram or trilinear diagram.
- Wilcox Diagram or irrigation quality diagram.
- STIFF Diagram.
- SCHOELLER Diagram.

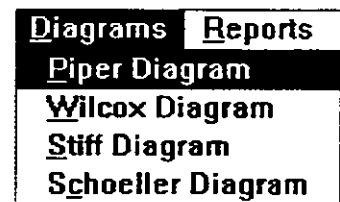

Figure 7-5

In addition to the explanation that follows in this Chapter, Chapter 16 Customization explains how to customize each of these diagrams, both for display and for print. Under the customization you will be able to select colors for each part of the diagram, select fonts (family and size), and select colors of labels. You will also have a chance to replace the words selected by the programmer with your own, in English or in any other language.

7.4.1. Stiff Diagram

The STIFF Diagram is named after H.A. Stiff, Jr. This is a single sample graph displaying graphically major cations and major anions. On the screen you will see only the graph but on the reporting form you may have all constituents (major, minor, rare, trace, contaminants, etc.) printed in a table, plus you may have a small loca-

tion map showing the relative position of the well being displayed. One example of the screen display of the STIFF diagram is shown in Figure 7-6.

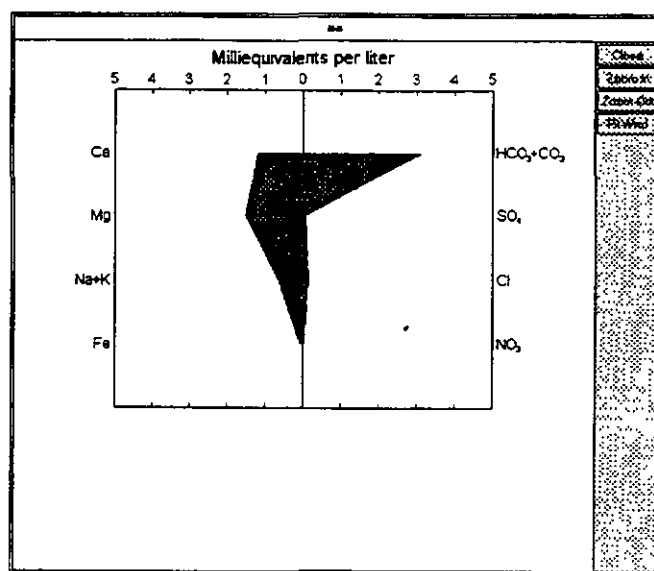

Figure 7-6

7.4.2. Piper Diagram

Named after A.M. Piper, the trilinear diagram presents graphically a group of analyses on the same plot. Figure 7-7 displays the upper part of the diagram, while Figure 7-8 displays the lower part with identification of wells/samples. The numbers on the left, 1 through 9 and letter A are codes that appear on the diagram itself. Next to these are well or sample identification names. You may display on one Piper Diagram as many samples as you wish, but the display list with sample identification may become crowded or may go beyond the page format. The number of samples you may actually display will depend on the report format you have selected, and on the font size you selected for printing the identification. With fonts as small as 8 points you may safely display and print up to 40 samples, aligned vertically in four columns containing 10 samples each. (If you select a larger font for labeling, fewer samples will be dis-

played.) Of course, you may always use larger paper or use landscape orientation.

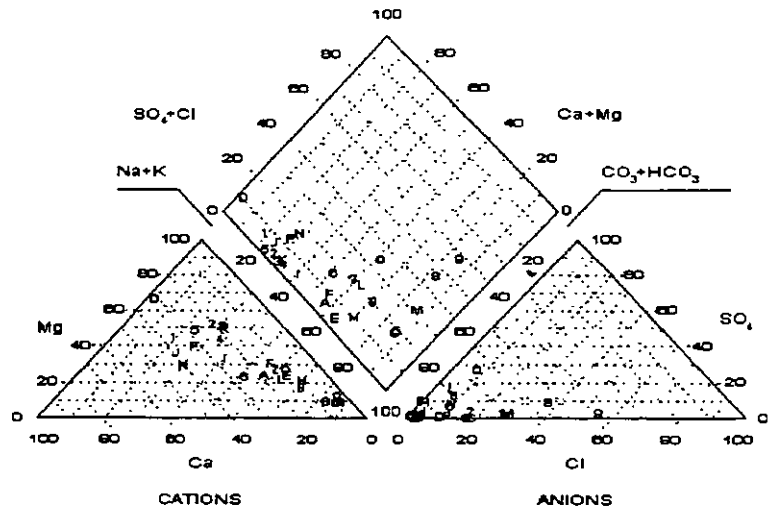

Figure 7-7

1 P-103	8 SRRG-13	F SRRG-21
2 P-110	9 SRRG-16	G SRRG-22
3 P-152	A SRRG-17	H SRRG-23
4 P-153	B SRRG-18	I SRRG-24
5 SRRG-10	C SRRG-19	J SRRG-28
6 SRRG-11	D SRRG-2	K SRRG-33
7 SRRG-12	E SRRG-20	L SRRG-33

Figure 7-8

7.4.3. Wilcox Diagram WILCOX Diagram is named after Wilcox from the U.S. Department of Agriculture. This diagram is used in studying the suitability of water for irrigation purposes. High content of exchangeable sodium is highly undesirable for agriculture, as is the high total dissolved solids content, expressed as conductivity of water. An example of a screen display of the Wilcox diagram is shown in Figure 7-9.

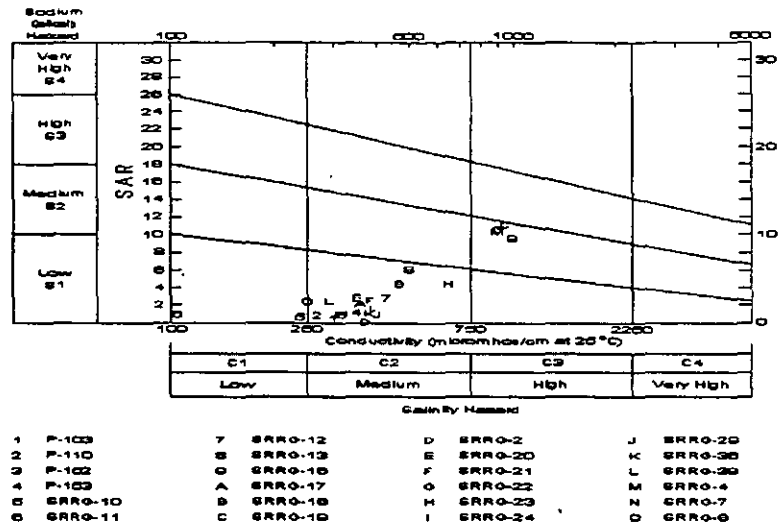

Figure 7-9

7.4.4. Schoeller Diagram.

The SCHOELLER Diagram, named after professor Schoeller, is a group diagram displaying (1) the total concentrations of major cations and anions in both ppm and epm, and (2) the relative water composition for many samples. Because of the graphical limitations of lines (solid, dashed, dashed dotted, and dots on the line) it is not advisable to display more than 10 samples on one Schoeller diagram. Read also section 7.6. Options. One example is shown in Figure 7-10.

7.5. TABLES

You may report or print data from the chemical data base in tables. Two table forms are designed by the GWW programmer as defaults for reporting major cations and major anions in (1) equivalents per million (epm), (2) parts per million (ppm). Their default names are Tableepm

and Tableppm. Both are set to report in the landscape orientation.

You may also design your own table reporting forms selecting any constituent and/or parameter that you may

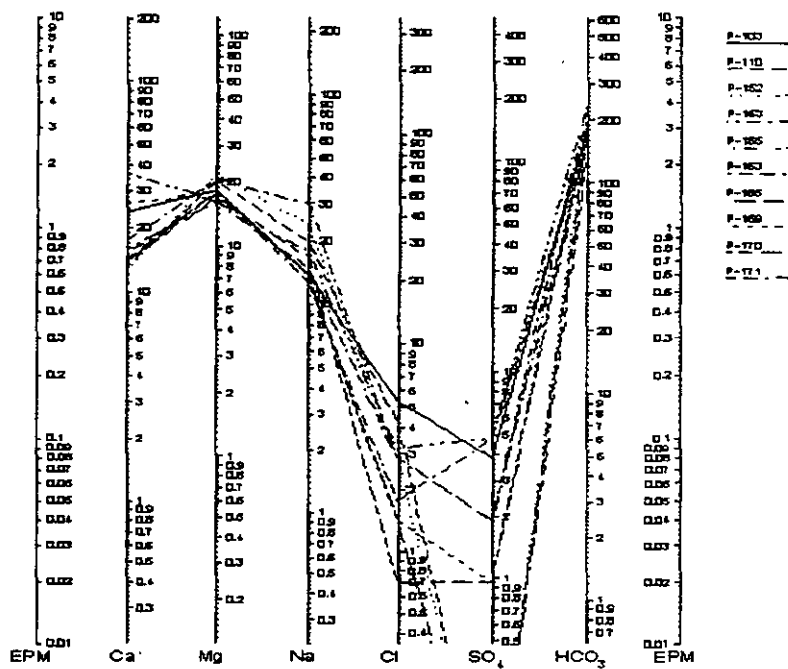

Figure 7-10

have in the data base. However, be careful in selecting the units of reporting. In the GWW system chemical constituents have simple chemical names such as Ca for calcium, NO3 for nitrates, etc. If displayed like this they will be reported as equivalent per millions. To distinguish epm from ppm for the same constituent, the GWW system adds ppm after the parameter name. For example Ca will be calcium in epm, but Cappm will be calcium in ppm. You may place either or both on the same table form. One such reporting form is reproduced in Appendix C. For advanced users of the GWW software, additional explanation of format and attributes is given in Appendix C.

7.6. REPORTS

When activated, the report option displays a pop-down submenu as shown in Figure 7-11. There is a difference in selecting to print using one of the four commands listed in the upper rectangle. When these print commands are activated, the program will assume that you want to use standard printing or reporting forms. You will not be prompted to select a reporting form, as you will be if you select one of the lowermost four options. Also the program will print only samples in the working group in the case of group diagrams (in upper rectangle).

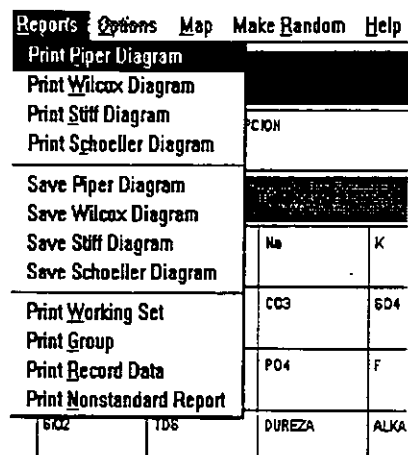

Figure 7-11

For example to print a STIFF diagram, you should select the sample you want to print by moving the cursor within the sample list on the left, or by using PageUp or PageDown if you are in the Entry Form window. Once you select the sample you have two options:

1. Select **Print Stiff Diagram** on the **Reports** menu. The standard reporting form will be used.
2. Select **Print Record Data**. The dialogue box will offer you all available reporting forms for the STIFF diagrams. Select one of these and the program will print it accordingly.

Using the commands from the lower rectangle permits you to select (a) the diagram to print, (b) the reporting form for that diagram, (c) the table form for all or a group

of constituents in the base, and (d) one of nonstandard reporting forms intended for mixing graphics using more than one application.

If you select **Print Working Set**, all forms designed by you or by the GWW programmer will be listed in a dialogue box, permitting you to choose from any of them. For example the list will include, by default, the diagrams such as Piper, Wilcox, and Schoeller, plus any other table form or alternative designs of diagrams that you may have created. You should be careful, however, not to select **Print Working Set** for a Piper diagram if you have more than 30 samples in the set. Likewise, it is recommended not to print more than 10 samples on a Schoeller diagram. In these cases, you are advised to use the command **Print Group**. The options **Print Working Set** and **Print Group** are identical except for the content of reporting.

You may also save any graphics that is currently displayed. Depending on which type of graphics is displayed you will use **Save Piper**, **Save Wilcox**, **Save Stiff**, or **Save Schoeller Diagram**. GWW will then open a dialogue box prompting you for the name of the drawing and for its dimension. You may print such a saved drawing using the **Print Nonstandard Report** option from this or another application.

7.7. OPTIONS

The GWW software uses a special external file to convert between ppm and epm values. This is a simple ASCII file, named by default PPMTOEPM.TBL, the partial content of which is shown below and its full content in Appendix D.

- Ca 0.04990
- Mg 0.08224
- Na 0.04350
- K 0.02558
- Fe 0.05372

- Mn 0.03640
- HCO₃ 0.01639
- CO₃ 0.03333
- SO₄ 0.02082
- Cl 0.02820
- NO₃ 0.01613
- PO₄ 0.03159
- SiO₂ 0.27750



Note. You may add more constituents and their conversion factors. The ppm values when multiplied by these factors convert to ep_m values.

Depending on what you have currently on your display, you may switch between ppm and ep_m at any time. The submenu with these options is shown in Figure 7-12.

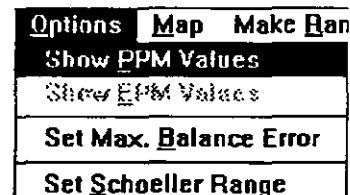

Figure 7-12

Set Max. Balance Error is another option which permits you to override the default built in the program. STIFF and PIPER diagrams will not calculate and display if there is an imbalance between sum of cations and sum of anions. By default the maximum permissible "imbalance" is set at 10%, but you may assign your own criterion using this option. When invoked, the dialogue box will be displayed as shown in Figure 7-13.

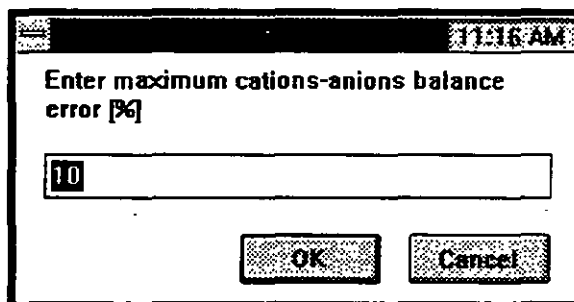

Figure 7-13

Set Schoeller Range is the option which permits you to change the vertical scale of the Schoeller diagram. By default, the range is set from 0.1 to 400 epm. The upper values are sufficient to display the sea water salinity, but are too high for an ordinary ground water sample. You will probably want to reduce the upper limit to some 30 epm, and also reduce the lower limit to 0.01 to display the smallest concentrations. When invoked this command first prompts you to set the minimum value for Schoeller diagram, as shown in Figure 7-14, and then to enter the maximum value for the same diagram.

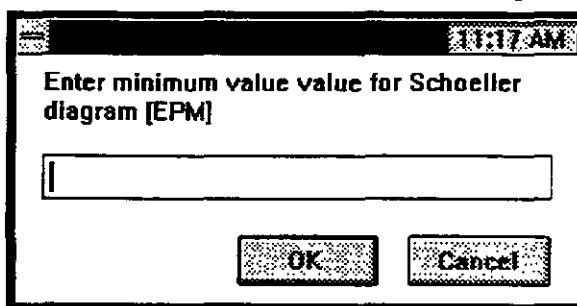

Figure 7-14

7.8. MAP

The **Map** option permits you to select wells or samples directly from the map. The submenu for **Map** is shown in Figure 7-15. You may create one or more maps showing locations of all or selected wells, water points or samples using the option **Make Random**, then the Mapping application in which you actually create a map.

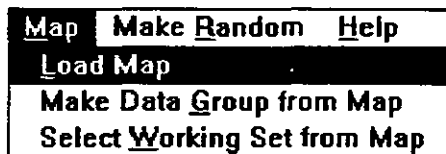

Figure 7-15

To select wells directly from a map you should follow the sequence:

1. Select **Data** on the menu bar.
2. Choose **Select Working Set**.
3. Click on **Unselect All** to remove all wells from the selection list.
4. Click on **OK**.
5. Select **Map** on the menu bar.
6. Select **Load Map** and select one of existing maps, the names of which will be listed in the dialogue box.
7. Depending on what you want to create a working group or a working set, select one of options **Make Data Group from Map** or **Make Working Set from Map**.
8. Use one of methods for selection of wells from the map: area, points, or rectangle. If you choose the option **Select Points** you must terminate the selection clicking on the button **End Points**. If you choose select **Area** you must terminate the selection clicking on **End Area**. Do not forget to close the area by selecting **End Point**. The option **Select In Rectangle** automatically closes the operation of selection. Notice that selected wells are listed in the selection window on the left side.
9. Select **Data**.
10. Select **Make Data Group** or **Select Working Set**, depending on what you have decided to create. You will notice that all the wells that were selected from the map are still displayed on the left part of the window under "Unselected Item". Confirm the selection by clicking on **Select All**.
11. Click on **OK**.

7.9. MAKE RANDOM

This option is explained in Chapter 5, section 5.6. In the chemistry application you may create random models for every chemical parameter, every constituent, for total dissolved solids, alkalinity, hardness, pH values, for to-

tal anions or cations, for sodium absorption ratio, or, in short, for every space-dependent item which has a numerical value. This in turn permits you to create a contour map for every such parameter.

When this option is invoked the dialogue box, like the one shown in Figure 7-16, will be displayed. The box lists all space-distributed parameters from the chemistry application and the master data application. When you select a parameter of which you wish to create a random point internal file, all wells or samples in the current working set will be scanned and included into the random points file, provided they have X and Y coordinates.

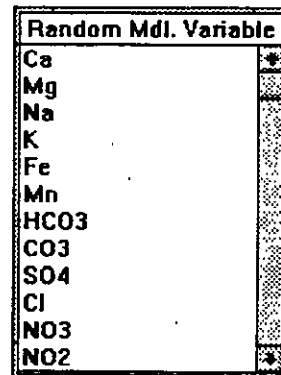

Figure 7-16

7.10. HELP

The final option on the menu bar is Help. This is a context-sensitive Windows-written help which explains almost everything explained in this manual.

7.11. EXAMPLE

EXAMPLE THREE

This is Example number three. The first task is to create a new data base with the following constituents in the base:



- TDS
- pH
- Conductivity
- Toluene
- Phenol
- Benzene
- Iron

The second task is to transfer the following data into the base:

- Well Identification - MW-1
- Description - Monitoring Well at Farmland Landfill
- TDS = 466 ppm
- pH = 8.2
- Conductivity = 412 micromhos per cm at 25°C
- Toluene = 4.5 ppm
- Phenol = 2.4 ppm
- Benzene = 2.3 ppm
- Iron = 2.4 ppm

You must follow the steps:

1. Create a new data file structure.
2. Create a new entry form.
3. Type data into the entry form and the data base.

7.11.1. Create a New Data File Structure

1. Start GWW and select **New GWW Data Base**.
2. Give the base the name **FARMLAND.GWW**.
3. Select **Tools**.
4. Select **Data Structure Design**.
5. Select **File**.
6. Select **Old**.
7. Select **Chemistry**.
8. Move the cursor to Ca and click on the button **Delete**.
9. Repeat with all constituents, deleting one by one. Retain only Well Ident, Fe (Iron), TDS (Total dissolved solids), pH, and Conductivity. What remains may look as shown in Figure 7-17.
10. Click on **New**.



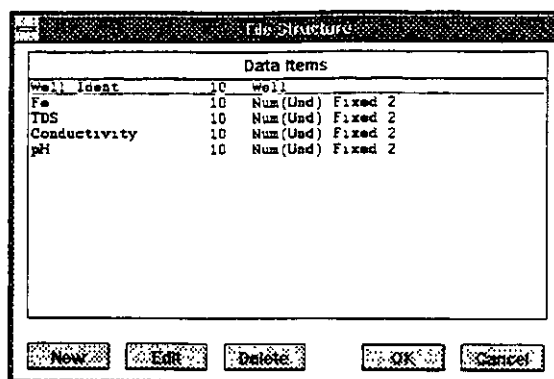

Figure 7-17

11. In the dialogue box type Toluene in New Field. Replace the default field length of 10 with 6. Click on **Numeric**. Replace the default number of decimal digits (2) with number 3. Click on **OK**. Notice that Toluene has been added to list of constituents on the last line.
12. Do the same for Benzene. Click on **New**, type Benzene for Field Name, 6 for Field length. Select **Numerical** for Data Type, and change 2 with 3 for Number of Decimal Digits. Click on **OK**.
13. Do the same for Phenol. The list of constituents should look as shown in Figure 7-18.
14. Click on **OK**. The changes are automatically recorded in your new data base.
15. Click on **File**, then on **Exit**.

7.11.2. Create a New Entry Form

1. Select **Tools**.
2. Select **Data Entry Forms Editor**.
3. Select **Chemistry**.
4. Select **Form**.
5. Select **New**.



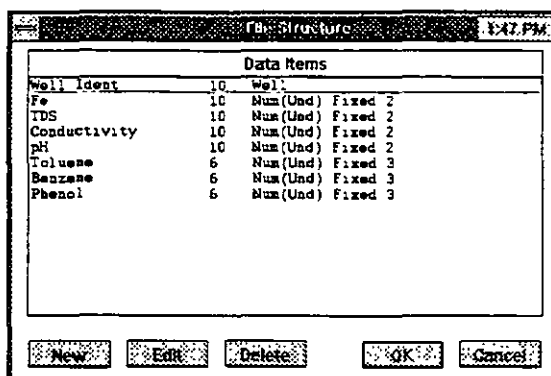

Figure 7-18

6. Select first **New Field, Header**, and type **EXAMPLE THREE ... New Chemical Data Base**. Enhance this field by adding border, changing fonts and other attributes.
7. Click on **Well Ident** from the list on the left side. See where the field is placed on the form. Move if you wish to another place. Change the default size, add border, change font to 12 or 14 points, boldface.
8. Click on **Description**. Change attributes if you wish.
9. Click on **pH**, then on **TDS**, then on **Conductivity**. Continue by selecting **Toluene**, **Benzene**, and finally **Phenol**. The form may look as shown in Figure 7-19.
10. When satisfied with the content and layout, click on **Form**, followed by **Save As ...**. Confirm by double clicking on **Standard**.
11. Click on **Form**, and on **Exit**.

7.11.3. Create Data Base Entry



1. Select **Applications**.
2. Select **Chemistry**.
3. Select **Data** menu.
4. Select **New Entry Form**, and double click on **Standard**.

EXAMPLE THREE .. Farmland Facility Chemical Data Base			
Well Ident			
Description			
Fe	TDS (ppm)	Conductvty	pH
Toluene	Benzene	Phenol	

Figure 7-19

5. Start typing, MW-1 in the **Well Identification** field, followed by TAB. Continue with the description field, then with other fields. Always end a field with the TAB key. When finished, press PAGE DOWN. The cursor is now in the blank **Well Ident** field, waiting for you to continue with another sample. If you press PAGE DOWN instead, or click with the mouse on MW-1 entry in the list of wells/samples, the screen should look something like what is shown in Figure 7-20.
6. To be sure that all common data are kept also in the Master Data application, close this application by selecting **Data**, and **Exit**.

EXAMPLE THREE .. Farmland Facility Chemical Data Base			
Well Ident			
MW-1			
Description			
Monitoring Well on Farmland Facility			
Fe	TDS (ppm)	Conductvty	pH
2.40	466.00	412.00	8.20
Toluene	Benzene	Phenol	
4.500	2.300	2.4	

Figure 7-20



7. Select **Application** again, and click on **Master Data**. Notice that the display contains only one well, MW-1. The only information shared between applications is Description. The display is as shown in Figure 7-21.

This ends example number three.

Master Data			
Ident	MW-1		
Description	Monitoring Well on Farmland Facility		
Easting	Northing	Ground Surface Elev	Measur Pt Elev
District	Locality	Owner	
			Map Sheet No

Figure 7-21

This page intentionally left blank.

8.1. GENERAL

Using the Well Log application on the main menu bar of the GWW software you may do the following:

1. Create a new well log by entering drilling data (depths and lithologic description of drilled layers) and construction data (hole and casing diameters, screen position, materials filling annulus).
2. Use the existing lithologic symbols for various lithologic members and/or materials filling the annulus or create new symbols directly on the screen.
3. Display a well log with its construction details on the screen.
4. Create a lithologic data base which will be used by other applications: the Cross Section, for creating lithologic cross section; the Fence Diagrams, for creating three-dimensional fence or block diagrams; and the Mapping application for creating various random models and contour maps.
5. Print a well log, using a default reporting form or forms that you created.

This application works in conjunction with three external ASCII files. One is named by default SCREEN.DLT, and for a new data base it must be contained in the GWW directory. It contains symbols for drawing a well screen and for painting both screen and blank casing. The other two files are named LITH.DLT and ANNULUS.DLT. The first file contains many pre-programmed lithologic symbols for displaying and printing various lithologic members. The second file contains several symbols that are commonly used in displaying materials filling the annular space between the drilled hole and well casing (such as conductor pipe, gravel pack, cement, clay, etc.). The

structure and details of these files are discussed in Appendix E.

As in any other application of the GWW system, you may enter "dedicated" data for wells using this application (lithology, construction details, materials filling the annulus, size of concrete block, etc.) and general data on a well using the Master data application (description, local name, coordinates, elevations, etc.).

The lithologic data and well construction, if you wish so, that you enter in this application are used in the Cross Section and in Fence Diagrams applications.

8.2. OPTIONS ON THE MENU BAR

As shown in Figure 8-1, the major options on the application's menu bar are the following:

The screenshot shows a window titled 'Well Log [c:\gww\quartz\gww]'. The menu bar includes: Data, W.L. Data, Display, Construction, Report, Lith.Units, Load Map, Make Random, Help. The main window is divided into a left sidebar with a list of well identifiers (BL132, PO-1, PO-3, PO-4, PO-5, SRRG-10, SRRG-3, SRRG-4, SRRG-5, SRRG-7, SRRG-8, SRRG-9) and a main data entry area. The data entry area is titled 'Well Lithology and Construction' and contains several tables. The first table has columns 'Well Ident' and 'Description'. The second table has columns 'X', 'Y', 'Z', and 'ZM' with values 734320.00, 3057920.00, 119.40, and 120.00. The third table is split into 'Concrete Block' and 'Scales' sections. The 'Concrete Block' section has columns 'Dx', 'Dy', and 'Height'. The 'Scales' section has columns 'Vertical' and 'Horizontal'. The fourth table has a column 'SWL' with the value 116.00.

Well Lithology and Construction				
Well Ident		Description		
X	Y	Z	ZM	
734320.00	3057920.00	119.40	120.00	
Concrete Block			Scales	
Dx	Dy	Height	Vertical	Horizontal
SWL		116.00		

Figure 8-1

- Data
- Well Log Data (abbreviated to W.L.Data)
- Display
- Construction
- Report
- Lithologic Units (abbreviated to Lith.Units)
- Load Map

- Make Random
- Help

Each of these options is explained in detail in this chapter.

When the Well Log application is selected, the display window consists of three main parts:

Menu bar on the top, in one or two lines depending on the screen resolution you are using (one line for 1024x768 or 800x600; two lines for 640x480).

List of wells on the left currently in the working set, with the number of wells. The first number tells how many wells are currently in the working set, and the second number tells the total number of wells in the lithologic application of the data base.

Entry form with information on the first well on the list or an empty form for a new data base.

8.3. DATA

The Data submenu is shown in Figure 8-2. The following options are available:

- Select Working Set.
- Delete Record.
- General Data Units.
- Change Entry Form.
- Standard ASCII Input.
- Standard ASCII Output.
- Printer Setup.
- Exit.

You use **Select Working Set** option in the same manner as with any other application. Its use is explained in Chapter 5,

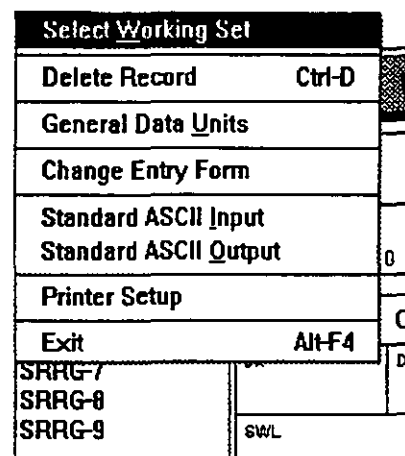

Figure 8-2

Section 5.3. Its purpose is to reduce a large set with many wells to a smaller set of wells which may be selected for whichever reason.

The general data units option permits you to (a) check which units you are currently using, and (b) modify any unit. For additional instructions on selecting units, see Chapter 4, Section 4.5.

To delete a record, do the following:

1. Move the cursor to the well you wish to delete.
2. Select **Data** on the application's menu bar.
3. Select **Delete Record**, or hold down the CTRL key and press D key.
4. A warning will be displayed giving you a chance to reconsider.

You may use the default entry form as displayed in Figure 8-1, or any form that you may have created following the steps explained in Chapter 3. To change the form:

1. Select **Data** on the application's menu bar.
2. Click on **Change Entry Form**.
3. Select the form name from the list displayed in the dialogue box which you wish to use as your entry form.
4. Click on **OK**.

You will notice that the new form has replaced the default form. (This selection is done only for a new data base. The program remembers which entry form you have selected and will display it next time you open the data base.)

The option **Standard ASCII Input** is used for input of more than one well. This is to say that you may input one, two, or as many wells as you wish from one ASCII file. The ASCII file may contain lithology and depth intervals, coordinates and elevations, construction details,

and static water level (SWL). If the file was created using the next option on the submenu, **Standard ASCII Output**, the file would contain by default all wells in the current working set including not only lithology but also the information on well construction, such as hole and casing diameters, screened intervals, and information on annulus.

An ASCII file with well log information may look as follows:

```
WELL: PO-1
X: 657900.00
Y: 949000.00
ELEV: 80.00
ELEV: 79.22
LITH:
  13.000 CLAY
  22.000 SANDF
  32.000 CLAY
  37.000 SAND
  44.000 GRAVEL
  63.000 SANDM
  71.000 GWS
  90.000 CLAY
 101.000 SAND SAND MEDIUM GRAINED
 106.000 CLAY CLAY WITH SOME GRAVEL
 109.000 CLAY
HOLE:
  10.000 0.600
  55.000 0.400
 109.000 0.200
CASING:
  10.000 0.500
  55.000 0.300
 108.000 0.100
SCREEN:
  15.000 20.000
  26.000 32.000
ANNULUS:
  10.000 CEMENT
  55.000 CLAYH
 109.000 GWS
```

The option **Standard ASCII Output** is used to save data in standard ASCII files. The data saved will include, as mentioned earlier all wells in the current working set, depth intervals, lithologic description, coordinates and elevations, and construction data. The format is the same as in the example above. For more detailed instructions on ASCII file read Chapter 5, Section 5.5.

The **Printer Setup** option is explained in Chapter 5, Section 5.4.

8.4. EDITING WELL LOG DATA

8.4.1. Editing Existing Data

To edit depths and lithology data for a well that is already in the data base, do the following:

1. Select **W.L.Data** from the application's menu bar. The only available option on the submenu is **Edit Log Data**, as shown in Figure 8-3.

2. Click **Edit Log Data** or press **ENTER**. A table such as the one shown in Figure 8-4 will be displayed. The table contains three columns. The first is Depth, the second Lith. Unit, and the third Comments. The depth value is the bottom of the layer described in Lith. Unit column. The code in this column must be listed in the ASCII

72% 10475K Free		
Data	W.L. Data	Display Constru
Help	Edit Log Data	
	Depth Data	
	Thickness Data	
	Depth/Thick. Units	
3		
19	Insert Row	Ctrl-I
21	Delete Row	Ctrl-D
3		
5	Save Log Data	Ctrl-S
6	Exit (don't save)	Ctrl-X

Figure 8-3

file which contains codes, description and symbols for each lithologic unit to be used in the data base. As

P0-1		
Depth (ft)	Lith. Unit	Comment
13	CLAY	
22	SANDF	SAND fine with some \medium grained sand
32	CLAY	
37	SAND	
44	GRAVEL	GRAVEL all granulations\ with sand
63	SANDM	
71	GWS	
90	CLAY	
101	SAND	SAND medium grained
106	CLAY	CLAY with some gravel
1000	CLAY	

Figure 8-4

mentioned in 8.1., one such file will be copied to the GWW directory under the filename LITH.DLT. Its structure, symbol creation and color codes are explained in Appendix E. You need to know now that each code is unique, and that its name must be typed exactly the same as it is typed in the ASCII file containing codes. If the code for sand is entered in LITH.DLT file as SAND, in this table you must also type SAND. If you mistype, or simply forgot the code, the program will stop and wait for a correct code. Also, if you type depth intervals out of sequence, the cursor will return to the wrong input. You will not be able to save the data unless you correct the input.

NOTE. Codes are case and content sensitive.

3. You may edit depth intervals, codes for lithologic units, and comments. You will notice that for some layers (intervals of depth) there is no comment, while in others there is additional description of lithology in the Comment column. This is interpreted in the following way. Each symbol in the file LITH.DLT is defined with a symbol name, which is the first word in the LITH.DLT file (CLAY, SILT), and a description which will show on the display and on the printed well log. This is one or more words after the symbol name. You have the option to have the default description of lithology typed on the well log or to type something different and/or expanded. If you decide not to type anything in the column Comment, the de-

fault description of lithology will be used from the file LITH.DLT. If you decide to type anything in the Comment column, the program will reproduce what you type and not the default. You may type long descriptions, but use backslash (\) as delimiters. The number of characters or words you will be able to type within the column width will depend on what font size you have selected, and the width of the column for the lithologic description.

4. For editing use keys TAB or ENTER to move to the next field, SHFT+TAB to return to the previous field, up and down arrows, or use the mouse cursor.
5. When you have finished editing, press the combination CTRL+S to save and exit. Other combinations are displayed in Figure 8-5. For example CTRL+I will insert a row, CTRL+D will delete a row. If you wish to exit without saving what you have just edited, hold down the key CTRL and press the key X.

W.L. Data	Display	Const
Edit Log Data		
Depth Data		
Thickness Data		
Depth/Thick. Units		
Insert Row		Ctrl-I
Delete Row		Ctrl-D
Save Log Data		Ctrl-S
Exit (don't save)		Ctrl-X

Figure 8-5

When you are in the editing mode, you may click on W.L.Data again. Now all options are available, as shown in Figure 8-5. Normally your data are entered as depths. You may select the option **Thickness Data**, and your data in the table that you are editing will be expressed as a thickness. The option **Depth/Thick. Units** allows you to change units for depths. When you select this option, the dialogue box will display a list of available units for length. Be careful, if you now select another unit, the depths currently in the data base will be multiplied by the corresponding conversion factor and expressed in new units. Make sure that this is what you wanted.

8.4.2. **Creating a New Log** To create a new well log, the procedure is the following.

1. In the Entry form type the new Well Identification name or number, using any combination of numbers and characters. Fill other fields with information. If the Well Identification name already exists in your data base (it will exist if you have typed some information for this well either in the Master data application or in any other application), the program will automatically fill in the fields that already have information. Normally this would apply to X and Y coordinates, ground surface elevation and well description.
2. Select **W.L.Data** and **Edit Log Data**. Type the data into the table. On the last line with information after you type a code for Lith. Unit, override the default description by adding another in the column Comment, hold down the CTRL key and press S.

We will stop here because you need to know more before you can create a log.

8.5. LITHOLOGIC UNITS

On the screen and in the report, the GWW program displays lithologic units as various symbols and colors. You do not need to add colors if you do not wish to print logs on a color printer. However you do need to have one lithologic symbol for each lithologic unit.

As mentioned before, these symbols are contained in a special ASCII file, named for the GWW by default as LITH.DLT. You must tell the program, when you start creating a new data base, this file's name and the path to find the file. This is accomplished using the option **Lith. Units** on the application's menu bar.

When this option is invoked you will be offered four choices, as shown in Figure 8-6:

- Edit Lithological Unit
- Standard ASCII Input
- Standard ASCII Output
- Delete Lithological Unit

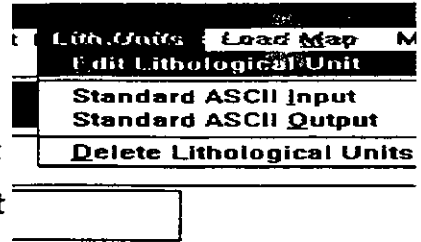

Figure 8-6

8.5.1. Read In File with Symbols for Lithologic Units

When creating a new data base you must start with the second option, Standard ASCII Input. The dialogue box will be displayed as shown in Figure 8-7 listing all files with extension .dlt (stands for "define lithology") in your

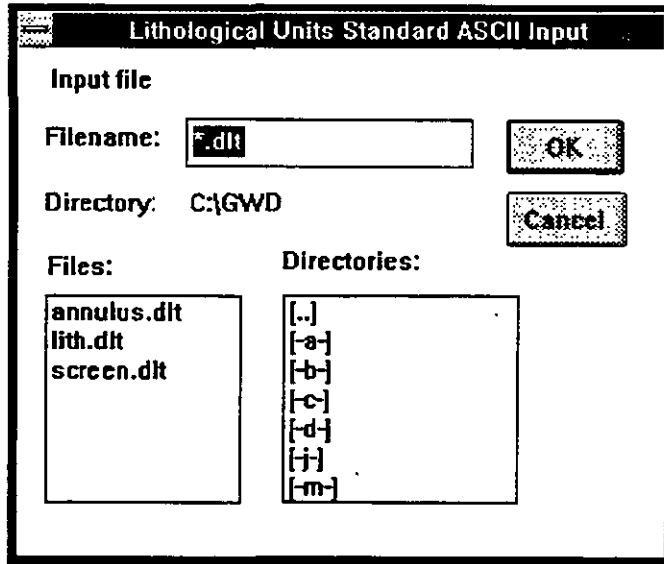

Figure 8-7

current working directory. In the case displayed there are three files with this extension:

ANNULUS.DLT, which contains several codes and symbols to be used for displaying materials filling the annular space;

LITH.DLT, the main file with all lithologic units to be used in the data base;

SCREEN.DLT, which contains two entries, one for screen and another for blank casing.

Each of these files is either completely or partially reproduced in Appendix E. You may change the name for the first and second, but not for the third. The program looks for the file screen.dlt in the GWW directory.

8.5.2. Edit Lithologic Symbols and Descriptions

You may edit a lithologic unit or you may add a new lithologic unit. To do this:

1. Select **Lith. Units** on the menu bar.
2. Select **Edit Lithological Unit**.

The screen will display a list with all currently available lithologic units. This is shown in Figure 8-8. The list is read from the file LITH.DLT which was used at some point in creating this data base. The first on this list is **New Lith. Unit**.

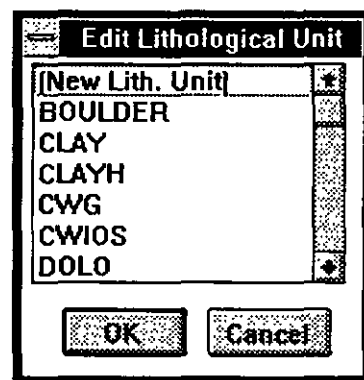

Figure 8-8

Editing of existing lithologic units is shown in Figure 8-9 for a unit coded as CWIOS. The acronym is user-definable. In this case it stands for "Clay With Interbeds Of Sand". You may use anything, but acronyms or codes should be easy to remember. For this unit the default description that will be typed on the log is: CLAY with interbeds of sand. You may modify this now, globally, for

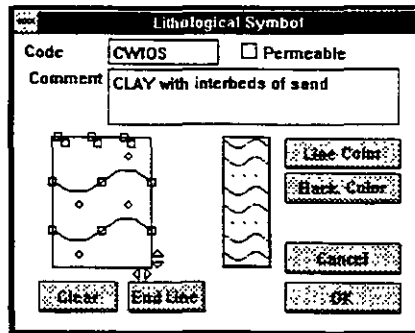

Figure 8-9

every occasion in which the code CWIOS will be used. Or you may keep it as it is, but modify it later on an individual basis using the Comment column in the Edit Log Data option.

Figure 8-9 also shows that you may assign various color attributes to both lines and background. If either is selected, a standard Windows color palette will be displayed from which you may select an appropriate color. You may also edit the symbol itself by adding points and lines to the rectangle on the left. By moving small markers up and down, or to the left or right, you may change the density of repetition of the symbol.

These steps allow you to design new symbols or modify the existing ones directly on the screen. The steps necessary to do this by modifying the ASCII file LITH.DLT will be discussed in Appendix E.

8.5.3. Deleting Lithological Units

You may delete one or more lithological units. As shown in Figure 8-6, you should select the last command on the menu, Delete Lithological Unit. The new dialogue box as shown in Figure 8-10 will open, with the list of all available lithological units. Highlight one or more of these units, as shown in Figure 8-11, and click on OK. The highlighted units will be removed from the list.

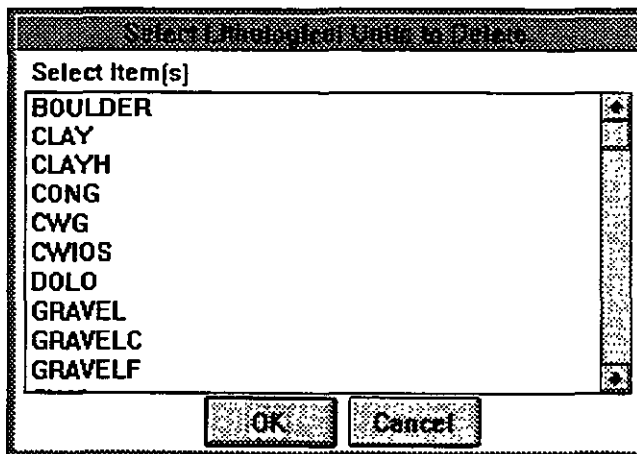

Figure 8-10

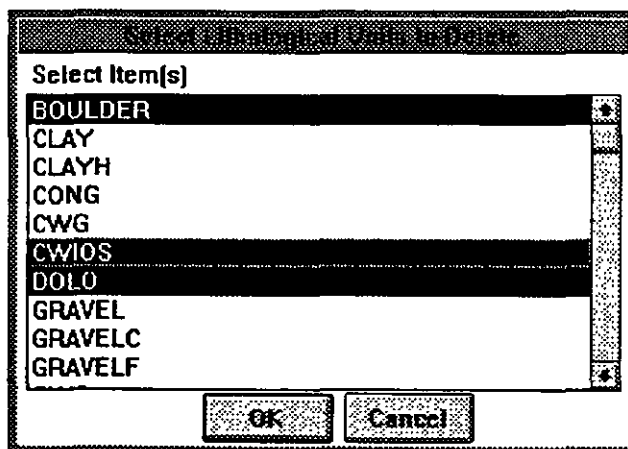

Figure 8-11

8.6.
CONSTRUCTION
DATA

On the application's menu bar the command **Construction** has the following options, as shown in Figure 8-12:

- Annulus
- Hole
- Casing
- Screen
- Constr. Units
- Annulus Materials

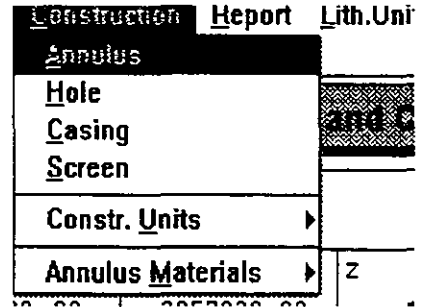

Figure 8-12

This last option branches into one of the three options, as shown in Figure 8-13:

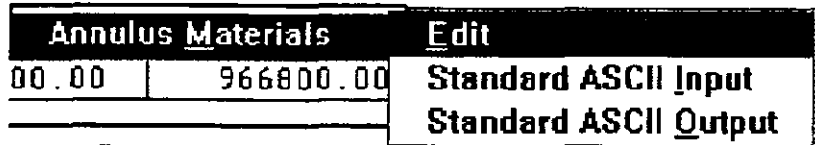

Figure 8-13

- Edit
- Standard ASCII Input
- Standard ASCII Output



NOTE. When editing existing data or entering new data (for annulus, hole, casing, and screen), after typing the last entry do not press TAB or ENTER because this will open a new line which would remain blank. End input by holding down the CTRL key and pressing S (for Save). If you do make a mistake, delete this blank line by holding down the CTRL key and press-

ing D (for Delete). Then use the combination of the keys CTRL and S to save.

8.6.1. Annulus

Using this option, you can transfer the data on various materials which fill the space between the casing and the hole, and specify the depth intervals for each of these. The display will look as shown in Figure 8-14, with two columns:

SRRG-9 – Annulus	
Ending Depth [m]	Annulus

Figure 8-14

- Ending Depth
- Annulus

In the column **Annulus** you should type the code for material filling the annular space (conductor, cement, clay seal, bentonite, gravel pack, gravel, sand, etc.). The codes you select here must have been already entered into the data base using the last option on this pop-down menu, **Annulus Materials**. Again it is essential that you type the codes in the same way they are typed in the file containing their symbols, codes, and descriptions. In the case above, this is the file **ANNULUS.DLT**.

In the column **Ending Depth**, you should type the end of the interval filled with materials selected under the column **Annulus**.

8.6.2. Hole

When you select this option and type the information, the display may look as shown in Figure 8-15.

PO-1 – Hole	
Ending Depth [m]	Diameter [m]
10	.6
55	.4
109	.2

Figure 8-15

8.6.3. Casing

Similarly, selecting the option Casing and typing information the display may look as shown in Figure 8-16.

PO-1 - Casing		
Ending Depth [m]	Diameter [m]	
15	0.5	
55	0.3	
108	0.1	

Figure 8-16

8.6.4. Screen

For the screen you do not type the diameter. It is assumed to be the casing diameter. You type the beginning and end of each screen section. The final display may look as shown in Figure 8-17.

PO-1 - Screen		
Starting Depth [m]	Ending Depth [m]	
15	20	
26	32	

Figure 8-17

8.6.5. Construction Units

You may select different units for length and for various diameters. The option for this is **Constr.Units** on the **Construction** menu, which branches into two suboptions as shown in Figure 8-18.

Construction		Report	Lith.Units	Load
Annulus				
Hole				
Casing				
Screen				
Constr. Units		Length Unit		
Annulus Materials		Diameter Unit		

Figure 8-18

8.6.5. Annulus Materials

If you wish the display and print to show the annular space filled with materials using symbols and colors, plus the description, you must read in the standard ASCII file which contains these symbols. Remember that the GWW program looks for two separate ASCII files, one for lithology and another for annulus-filling materials.

8.7. DISPLAY

You may display a well log at any time. It may show only intervals of depth without any description and symbols. This will happen if you did not input the ASCII file with codes, symbols and description of lithology. It may display intervals, lithologic symbols and description of units but without any construction details. This will happen if you did input the lithology ASCII file, but not construction details. It may display construction, annulus-filling materials, and lithology, as shown in Figure 8-19, if you have all associated files in the data base and have entered construction information. (The display will even show the height at scale of a concrete block on the surface.)

To display a drilling and construction log of a well you should:

1. Select, using cursor or up and down arrows, the well that you wish displayed.
2. Select **Display** from the menu bar.

The log will be displayed without any further intervention. Once displayed, you may zoom a portion, or use the option **Fit Wnd** (Fit Window). Notice that the hori-

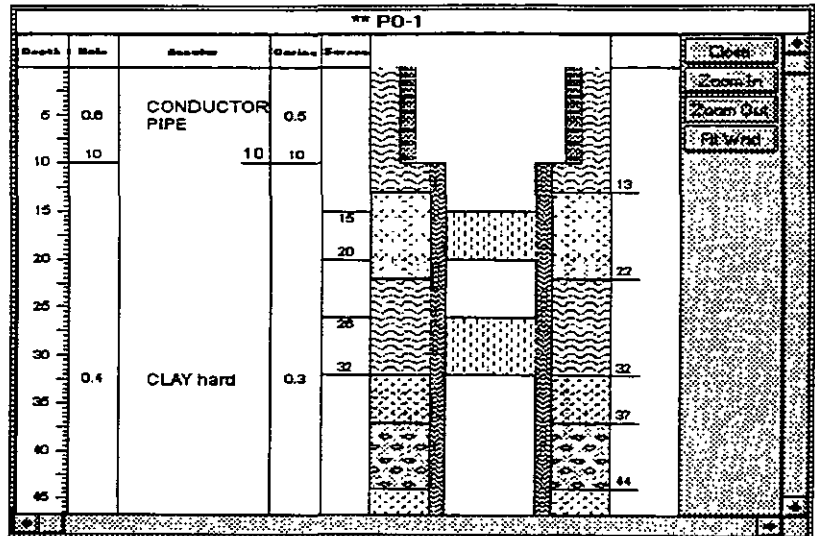

Figure 8-19

zontal and vertical scale of a log will depend on what you have selected in your Entry form. Assuming that you are going to print using the USA letter format, that is 8.5x11 inches, with the standard default form created by the programmer for the GWW package you will have 20 cm for the log. For a well 100 m deep 1:500 would be an adequate scale. If you want to print a well about 200 m deep you should change the scale to 1:1000. Assuming a well was drilled with an initial diameter between 0.2 and 0.6 m, selecting 1:40 for the horizontal scale would make the log between 0.5 and 1.5 cm wide. Notice, however, that the entire well log column will expand or stretch, depending on the horizontal scale you have selected, at the expense of other columns. If you have too much text to type in a narrow column (lithology or annulus), change fonts selected for typing. See Chapter 16

Customization for selecting fonts for the display and printout of a well log.



You may display static water level, or any water level on the log. Prepare your Entry form with the entry SWL. (You should have first "created" this item to be a part of the data base using the Data Structure Editor for Lithology.) Remember to type the SWL as absolute elevation, not the depth to water table. This value will be subtracted from the measuring point elevation (Zm) or land surface elevation (Z) and displayed as a line with inverse triangle in the column describing lithology or well construction.

8.8. REPORT

You may print a well log using the option Report from the application's menu bar. As shown in Figure 8-20 you will have to select between two reporting options:

- Print Log
- Print Table

The option **Print Log** will print the log of the well currently selected. The option **Print Table** will print information, in a tabular form, for all wells that comprise the current working set. The information which will be printed will depend on what you have declared in the report form. When you select to print using one of options in the upper two lines of the menu, the program will prompt you to select a reporting form. The next two lines of the menu do the same, except you must first select a reporting form and then decide to print by clicking on one of the options above.

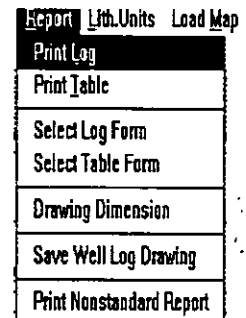

Figure 8-20

The option **Drawing Dimension** is useful for deciding on vertical scale of a log. When activated, it prompts you

first for a reporting form, and then displays the length of the log and the number of pages it will be printed on.

You may also save a well log drawing for placing it on a nonstandard reporting form, eventually mixed with other graphics. For this, you use **Save Well Log Drawing** option, followed by **Print Nonstandard Report** from this or another application.

8.9. LOAD MAP

This option is explained in detail in Chapter 5, subsection 5.3.2. It is used to select a working set, or wells to work with directly from a map.

8.10. MAKE RANDOM

This routine is explained in more detail in Chapter 5, Section 5.6. The program will allow you to select any one of the space distributed numeric parameters available for this application, including some that may have no meaning for contouring (e.g., scales, size of concrete block, etc.). Likewise, the static and dynamic water levels (SWL and DWL) may have no meaning if they were taken at different dates.

You may decide to include for your project some parameters that will define the thickness of a major aquifer, the elevation of its top or bottom, or the elevation of a major stratigraphic unit. With this information in the data base you may contour or place various elevation lines on lithologic cross sections.

With the data currently in the well log part of the data base, the only parameters that are space-dependent and have numerical values are the ones shown in Figure 8-21.

8.11. HELP

The final option on the menu bar is Help. This is a context-sensitive Windows-written help which explains almost everything explained in this manual.

Random Mdl. Variable
SWL
DWL
ConcrBlockDx
ConcrBlockDy
ConcrBlockH
Above GS
Vert.Scale
Hor.Scale
X
Y
Z
ZM

Figure 8-21



E
XAM
PLE

EXAMPLE FOUR

As an example you will create a well log for the following case:

Lithology (in feet):

0-10 Clay
 10-16 Sand fine grained
 16-22 Sand with gravel
 22-36 Clay
 36-48 Sand
 48-55 Silt

Hole diameter:

0-10 12 inches
 10-55 6 inches

Casing diameter:

0-10 6 inches
10-55 3 inches

Screen set in two intervals: 16-22 and 36-48 feet.

The upper 10 feet are cemented, and the rest is filled with gravel pack composed of sand and gravel.

For lithology description and annulus-filling ASCII files use the default files: LITH.DLT and ANNULUS.DLT.

You will start by filling in the fields in the Entry Form. Give the name to the well MW-1. Select the vertical scale 125. The horizontal scale is not important. The program uses its default. When this is done, continue as follows:

1. Select **Lith.Units**.
2. Select **Standard ASCII Input**.
3. Click on the file name Lith.dlt in the \GWW directory.
4. Select **W.L.Data** from the menu bar.
5. Select **Edit Log Data**.
6. Select again **W.L.Data**. The whole menu is now available.
7. Select **Depth/Thick.Units**.
8. Double-click on feet. Notice that the depth column in the table is now in feet.
9. Type 10 and press TAB.
10. Type CLAY (with all upper-case letters). Press TAB.
11. Type 16, press TAB; type SANDF and press TAB.
12. Type 22, press TAB; type GWS (acronym for gravel with sand), press TAB.
13. Type 36, press TAB; type CLAY, press TAB.
14. Type 48, press TAB; type SAND, press TAB.



15. Type 55, press TAB; type SILT and do not press TAB. If you press it and there is a blank line for one more layer hold down the CTRL key and press D to delete the line. The screen displays a table similar to the one shown in Figure 8-22.

MW-1		
Depth(feet)	Lith. Unit	Comment
10	CLAY	
16	SANDF	
22	GWS	
36	CLAY	
48	SAND	
55	SILT	

Figure 8-22

16. Hold down the CTRL key and press S to save the table.
17. Select **Construction**.
18. Select **Annulus Materials**.
19. Select **Standard ASCII Input**.
20. Select the file name ANNULUS.DLT from the GWW directory.
21. Select **Construction** again and confirm Annulus (press ENTER). Notice that units are meters.
22. With the table open, select **Construction**, then **Construction Units**. Double click on feet. Notice that the table displays feet units.
23. Type 10 and press TAB, then type CEMENT and press TAB.
24. Type 55 and press TAB, then type GWS. The screen displays the table as shown in Figure 8-23.
25. Hold down the CTRL key and press S to save the data.
26. Select **Construction** again and select **Hole**. The table opens but with metric units. Select **Construction**, then **Construction Units** and double click on feet.



MW-1 – Annulus		
Ending Depth [feet]	Annulus	↑
10	CEMENT	
55		

Figure 8-23

27. Type 10 and press TAB, then type 1 (one foot) and press TAB.
28. Type 55 and press TAB, then type 0.5 (for 6 inches expressed in feet). The table as shown in Figure 8-24 is displayed.
29. Hold down the CTRL key and press S to save the data.

MW-1 – Hole		
Ending Depth [feet]	Diameter [feet]	↑
10	1	
55	.5	

Figure 8-24

30. Select **Construction** again, then select **Casing**. Notice that units are meters.
31. With the table open, select **Construction**, then **Construction Units**, then double click on feet. Notice the change of units.
32. Type 10, press TAB, type 0.5 (6 inches, in feet).
33. Type 55, press TAB, type 0.25 (3 inches, in feet). The table as shown in Figure 8-25 is displayed.
34. Hold down the CTRL key and press S to save the data.



MW-1 – Casing	
Ending Depth (feet)	Diameter (feet)
10	.5
55	.25

Figure 8-25

35. Select **Construction** again, then select **Screen**. Notice that units are meters.
36. With the table open, select **Construction**, then **Construction Units**. Double click on feet. Notice that the table displays feet units.
37. Type 16, press TAB, type 22, press TAB.
38. Type 36, press TAB, type 48. The display is as shown in Figure 8-26.

MW-1 – Screen	
Starting Depth (feet)	Ending Depth (feet)
16	22
36	

Figure 8-26

39. Hold down the CTRL key and press S to save the data.

Now that all information for this well has been inputted, you may display the log. Select **Display**. Practice with **Zoom In**, **Zoom Out**, and **Fit Wnd** (Fit to Window). The log may look on the screen as shown in Figure 8-27.

This ends example four.

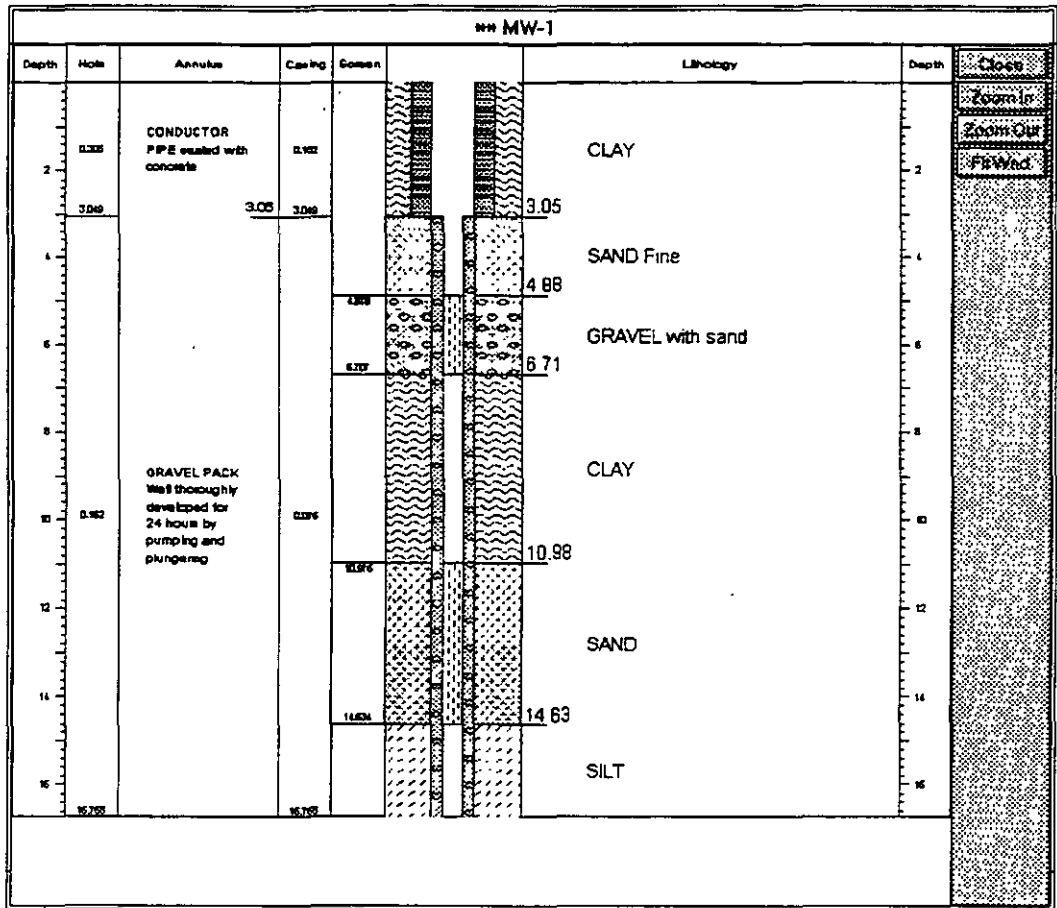

Figure 8-27

CHAPTER NINE . PUMPING TEST APPLICATION

9.1. INTRODUCTION

9.1.1. General

Using the Pumping Test application from the main menu of the GWW software you may do the following:

1. Create a data base containing information about pumped wells, field test data (drawdowns, time, pumping rates).
2. Interpret field data by fitting one of the theoretical curves for nonleaky aquifer, leaky aquifer, under confined or unconfined conditions, with fully or partially penetrating wells.
3. Display the field data or fitted data on the screen or print them using one of three display options:
 - (a) both time and drawdown coordinate axes are at logarithmic scale;
 - (b) both time and drawdown coordinate axes are at linear scale;
 - (c) time (abscissa) is at logarithmic scale, and drawdown (ordinate) is at linear scale.
4. Print the results in one of the following forms: (a) table form with general data on wells and hydrogeologic parameters, (b) table form with measured and fitted data for one well, and (c) standard reporting forms showing the pumping test data and fitted curve.
5. Prepare the data on hydrogeological parameters for contouring. Normally you would like to produce a contour map of transmissivity, or prepare an input data file with transmissivities and hydraulic conductivities to be used for modeling.

9.1.2. Features Of The Interpretation Mode

The program permits you to specify the following:

- Aquifer may be confined or unconfined. If unconfined, the program adjusts drawdown data for decrease in the transmissivity using the formula derived by Jacob:

$$s' = s - (s^2/2m)$$

where:

s' = drawdown that would occur in an equivalent nonleaky confined aquifer;

s = observed drawdown under water-table (unconfined) conditions;

m = initial saturated thickness of aquifer.

- Wells are expected to be fully penetrating but corrections for partial penetration are included for the case of nonleaky aquifer. The program permits partial penetration of pumped or observation wells. In the case of partial penetration, you will be prompted for additional input, such as the depth to the top and bottom of a well screen from the top of aquifer in the pumped well, as well as the same for an observation well.

The program has four major curve fitting routines:

- (a) Theis, using the standard well function $[W(u)]$ curve fitting method;
- (b) Jacob's approximation of the Theis solution;
- (c) Hantush, using the standard leaky well function $[W(u,r/B)]$ curve fitting method;
- (d) Recovery method.

In all cases the program does the fitting without prompting you for initial guesses. (The initial guess is provided by first solving the Jacob's approximation equation and

producing the approximate fit, and then solving the complete well function equation.)

The Jacob's method is an approximation to the solution provided by the much more involved Theis method which is valid only when a certain condition is satisfied. This condition is contained in the size of the well function's argument. The argument u is defined as:

$$u = r^2 S / 4 T t$$

where r is the distance between pumped and observation wells, t is the time of pumping, and T and S are aquifer parameters transmissivity and storage coefficient, respectively.

This condition, expressed as the well function's argument u being less than about 0.01, implies that the distance between pumping and observation well, r , should be small or the time of pumping large. For a certain range of the aquifer parameters, namely the transmissivity T and the storage coefficient S , this condition will not be satisfied. For example, the Jacob's approximate solution will not be valid for the following set of values:

$r=500$ m; $S=0.10$; $T=500$ m²/day; t from 1 to 100 days.

The pumping test does not need to be run with a perfectly stable pumping rate. Pumping rate fluctuations are allowed and curve fitting will take them into account provided the history of pumping is known (exact rates and times of changing rates). Theoretically, the method can be used for the whole step-drawdown test as well.

You may skip any test data from curve fitting. These points will still be shown on the screen and on the printed graph but with a different symbol and color.

9.1.3. Input Data Conventions

The data for a pumping test analysis normally consist of four entries:

- time
- drawdown or depth to water from a measuring point

- pumping rate
- option to skip the point from calculation

Each data set must start with the initial line (row in the editing table) containing 0 (zero) for the time, 0 for the drawdown, and the initial pumping rate. For example, if a well was pumped at 2500 m³/day, and the drawdown after the first minute was 2.34 m, after the second minute 3.21 m, etc., the data input must look as follows:

Time	Drawdown n	Rate	Skip
0	0	2500	
1	2.34		
2	3.21		

However, you may type a positive value for the drawdown at time zero (row one) indicating that you wish the program to accept this as the initial static water level. This level is actually the depth to the water from the measuring point (top of casing, ground surface, top of concrete block, etc.). Every other value in the second column ("drawdown" column) will be interpreted as the depth to the water and the vertical axis on the pumping diagrams will be labeled accordingly.

There is no need to repeat input of pumping rates as long as the rate is constant. Only when it changes, the change should be typed.

In the case of the recovery of water levels after the pump stopped discharging, the convention is the following:

You must provide the history of pumping during the pumping stage, ending the pumping with the line containing the final time of pumping, and the final drawdown, and replacing the pumping rate with 0 at the time pump was shut off. From that time on, the time input must be in total time elapsed from the beginning of pumping, and not from the moment the recovery started. For example, if a well was pumped for 240 minutes at a constant rate of 2500 m³/day and the final drawdown was equal to 1.00 m, and then the pump was

shut off and the recovery measured, the data input must be the following:

0	0.00	2500
240	1.00	0
241	0.89	
242	0.81	
243	0.76	
245	0.68	
247	0.64	
250	0.56	
255	0.49	
260	0.45	
270	0.38	
280	0.34	
300	0.28	
320	0.24	
340	0.21	
380	0.17	
420	0.14	

(This is the example from D.K.Todd's book *Groundwater Hydrology*, 2nd edition, 1980, page 133. The manual matching produced the transmissivity equal to 1140 m²/day, and this program 1162 m²/day.)

9.1.4. Aquifer Parameters

With the Theis method for a nonleaky aquifer, the fitting method produces the values of transmissivity and storage coefficient. Using the Hantush method for a leaky aquifer, the fitting method produces the transmissivity, the storage coefficient and the leakance or leakage coefficient. While the physical meanings and interpretation of the transmissivity and storage coefficients is well known and fully explained in any basic textbook on hydrogeology, the leakage coefficient needs an explanation.

The leakance or leakage coefficient, defined as K'/b' , where K' and b' are the hydraulic conductivity and thickness, respectively, of the semiconfining layer separating two aquifers, characterizes the amount of leakage. This coefficient is defined as the quantity of water that

flows across a unit area of the boundary between the main aquifer and its semiconfining bed, if the difference between the head in the main aquifer and that of the ponded water supplying leakage is unity (De Wiest, *Geohydrology*, 1965, page 274). Usually the values of the leakage coefficient are expressed in 1/time unit, that is in day^{-1} , or sec^{-1} . Hantush reported values between $4.8 \times 10^{-8} \text{ sec}^{-1}$ to $10^{-10} \text{ sec}^{-1}$ for an artesian basin in New Mexico, while Walton reported values from $3.5 \times 10^{-7} \text{ sec}^{-1}$ to $8 \times 10^{-9} \text{ sec}^{-1}$ for glacial drift deposits in Illinois.

The recovery method will produce only the transmissivity coefficient. Although it would be relatively easy to report the storage coefficient as well, the programmers restricted the analysis to transmissivities following the classical approach to the recovery part of the test.

In general we do not know beforehand whether an aquifer is leaky or nonleaky. You should try both methods, Theis and Hantush, and accept the one which produces a better fit. The quality of fit is printed as the Estimation Error entry. This is, in essence, the standard deviation.

9.1.5. Units

Although the GWW package has its system of units in the file GWW.UNT, you may override the basic units in every part of the program. For the pumping test application this is more important than for other applications, because this application involves calculation of parameters which must be done in a consistent system of units. You should not be concerned with the consistency. The program takes care of this. But you must have control over your input data by knowing in which units you are actually transferring the data. You must also specify in which units you wish to have the results for the parameters.

As you will soon notice, the program permits you to modify general units and measurement units. The general units are the units for transmissivity and leakance, for average pumping rate to be reported on the form,

and for various geometric input parameters in the case of partial penetration and unconfined aquifer. The measurement units are the units for time, drawdown and pumping rate. The units you select for measured data will be displayed in the editing table. The general units will not be displayed on the screen, nor in reporting forms. You must be sure of which units you have selected and label them properly by modifying the default reporting forms.

9.2. MAIN MENU BAR

As shown in Figure 9-1, the major options on the application's menu bar are the following:

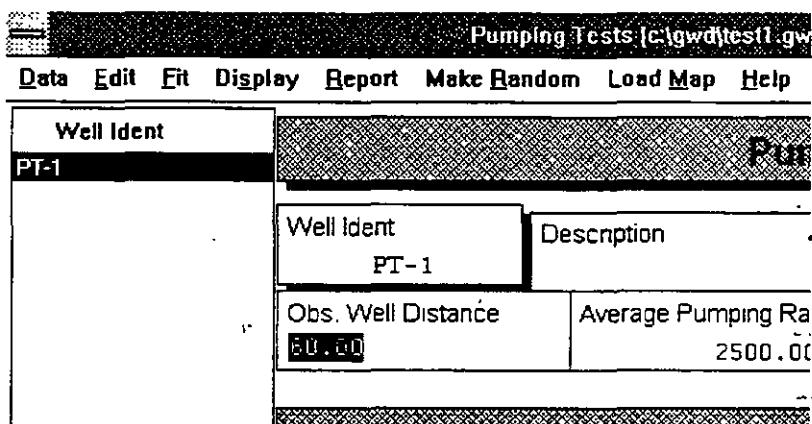

Figure 9-1

- Data
- Edit
- Fit
- Display
- Report
- Make Random
- Load Map
- Help

Each of these options, except options **Make Random** and **Load Map**, is explained in detail in this Chapter. **Make Random** is discussed in Chapter 5, Section 5.6; **Load Map** is discussed in Chapter 5, Section 5.3.2.

When the Pump Test application is selected, the display window consists of three main parts:

- Menu bar on the top.
- List of wells on the left currently comprising the working set, with two numbers at the top referring to the number of tests in the current working set and the total number of pumping tests in the data base.
- Entry form with information on the first well on the list or an empty form for a new data base.

Only certain fields on the entry form are available for input. These are Well Ident (or identification of a well), Description of the well, and Obs. Well Distance. In all but the recovery method, you will be reminded to input this parameter if you forget to do so before fitting.

Other fields on the form are reserved for reporting the results, and you will not be permitted to modify them. These are the fields reporting the transmissivity, storage coefficient, leakance, estimation error, initial saturated thickness, and the fit method.

NOTE. If you wish to keep in your data base transmissivity, storage coefficients, leakance, hydraulic conductivities, etc. which you may modify or input without accepting the results from pumping tests, you must modify the data structure internal file (see Chapter 2) and reporting forms (see Chapter 3). However, be careful not to assign to these new entries the same field name as in the default structure. Remember that the default field names are transmissivity, storage, leakance. If you wish to have double parameter for transmissivity, you may add to the data structure TRANS, place this entry on your entry and reporting form, type the value that you wish to accept as the representative value for the transmissivity into this TRANS field in the entry form, in addition to the value produced automatically by the test, and create the same field on a



new reporting form in which the transmissivity as selected by you will be reported. This may become important if you wish to create a transmissivity contour map by using pumping tests results for a certain number of wells, by using calculated transmissivities from grain size analyses, and by assigning transmissivities on the basis of well performance or merely the lithology.

9.3. DATA

The Data submenu is shown in Figure 9-2. The following options are available:

- Select Working Set.
- Delete Record.
- Select Entry Form.
- General Data Units.
- Print Setup.
- Exit.

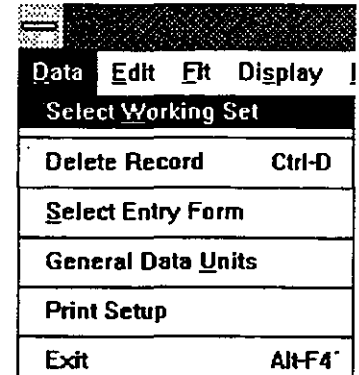

Figure 9-2

You use **Select Working Set** option in the same manner as with any other application. Its use is explained in Chapter 5, Section 5.3. Its purpose is to reduce a large set with many wells to a smaller set of wells which may be selected for whichever reason.

To delete a record, do the following:

1. Move the cursor to the well you wish to delete.
2. Select **Data** on the application's menu bar.
3. Select **Delete Record**, or hold down the CTRL key and press D key.
4. A warning will be displayed giving you a chance to reconsider.

You may use the default form as displayed in Figure 9-1, or any form that you may have created following the steps explained in Chapter 3. To change the form:

1. Select **Data** on the application's menu bar.
2. Click on **Select Entry Form**.
3. Select the form name which you wish to use as your entry form from the list displayed in the dialogue box.
4. Click on **OK**.

As explained in Section 9.2., in the pumping test application it may be important to design another entry form which would give you an opportunity to type some additional values, such as for transmissivity, hydraulic conductivity, storage coefficient, leakance, conductivity of semi-confining bed, thickness of semiconfining bed, etc. These values may then be contoured or reported in a table.

When activated, the option General Data Units displays a dialogue box such as shown in Figure 9-3. You may change units for every parameter that may appear in the calculation or on the entry or reporting form. Remember that the slide bar on the right indicates that there are more entries than what is displayed. Most of these parameters will appear on the entry and reporting forms. When you select any of these parameters, you will be offered the full choice of units, all units that are specified in the GWW.UNT file for a particular type of units.

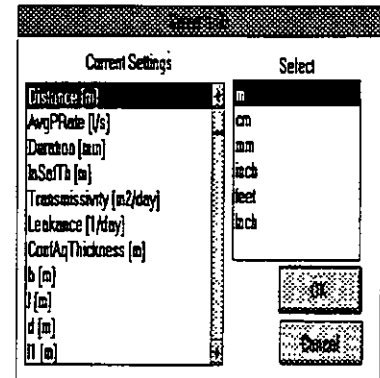

Figure 9-3

The Print Setup option is explained in Chapter 5, Section 5.4.

9.4. EDITING PUMP TEST DATA

9.4.1. Measurements Units

The submenu Edit looks as shown in Figure 9-4. To start, you should select or confirm the units of measurements

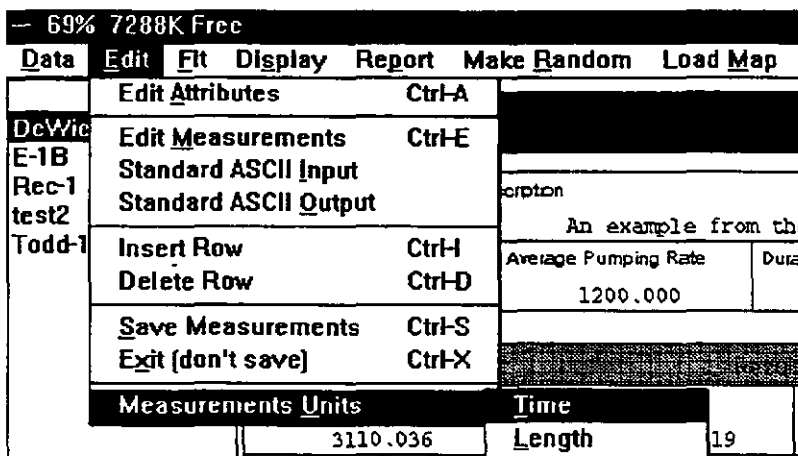

Figure 9-4

for a particular test. When you click on Measurements Units, the menu extends to three options: Time, Length, and Pumping Rate. The selection of units is the same as for the general data. When you select the option **Edit Measurements** the units that you have selected will be displayed in the editing table. This is shown in Figure 9-6.

9.4.2. Edit Attributes

Using the option **Edit Attributes** you may define your pumping test and aquifer scenario. The display as shown in Figure 9-5 looks like this only if you click on Partial Penetration box and declare the test as a partial penetration setup. If you do not select Partial Penetration

box, the display will offer only the Confined box. Actually, the following combinations are possible:

- (a) Confined aquifer box clicked. The box is "crossed". Partial penetration

The screenshot shows a dialog box with the following elements:

- Title bar: PT 1
- Group box 1:
 - Confined
 - Initial Sat. Thickness: [] m
- Group box 2:
 - Partial Penetration
- Buttons: OK, Cancel
- Section: Pumping Well Data, from Top of Aquifer ...
 - ... to Top of Screen: [] m
 - ... to Bottom of Screen: [] m
- Section: Observation Well Data, from Top of Aquifer ...
 - ... to Top of Screen: [] m
 - ... to Bottom of Screen: [] m
 - Aquifer Thickness: [] m

Figure 9-5

- box is not clicked (it is empty). No other input is required.
- (b) Both the confined aquifer box and partial penetration boxes are empty. The case is of an unconfined aquifer. You must type the value for Initial Saturated Thickness.
- (c) Both confined aquifer box and partial penetration boxes are clicked. The display is as shown in Figure 9-5. You do not fill the box for Initial Sat. Thickness, but you must fill in all boxes underneath, depending on whether you have measured data from the pumping well or from observation well.
- (d) Confined aquifer box is not clicked (the case is of a unconfined aquifer). Partial penetration box is clicked. You must type the value for initial saturated thickness and all required information for partial penetration.

9.4.3. Edit Measurements

When you select the **Edit Measurements** option, the edit table is displayed. It may contain data as shown in Figure 9-6, or it may be empty prompting you for input. Notice the units displayed in the header. These are the units you have selected using the option Measurements Units on the same menu. Notice also the first row of the data,

with 0 for time and drawdown, and a value for pumping rate. You enter or edit data using the TAB key, ENTER, or mouse.

NOTE. Remember that you must not press TAB or ENTER when you finish typing of the last data input. If you do a new line will automatically be opened. Since it would be blank the fitting would fail.

For this not to happen the program will warn you to delete the line. To delete any line, including the last blank line, you hold down the CTRL key and simultaneously press D.

You do not need to keep repeating the pumping rate value. Only if it changes should you type the new value. The "Skip" column allows you to eliminate some points from the calculation of the fit. Type * on the row you wish to eliminate.

PT-1			
Time(min)	Depth(ft)	Q (in ³ /day)	Skip
0	0	2500	
1	0.2		
1.5	0.27		
2	0.3		
2.5	0.34		
3	0.37		
4	0.42		
5	0.45		
6	0.48		
8	0.53		
10	0.57		
12	0.6		
14	0.63		
18	0.67		
24	0.72		
30	0.76		
40	0.81		
50	0.85		
60	0.9		
80	0.93		
100	0.96		
120	1		
150	1.04		
180	1.07		
210	1.1		
240	1.12		

Figure 9-6

9.4.4. Standard ASCII Input

You may input pumping test data from an ASCII file. This should be a standard ASCII file, with time, drawdown, and pumping rate values separated by a comma or one or more spaces. The order of input is important: time, drawdown, pumping rate. When you choose the option Standard ASCII File the box prompting you to select a file will be displayed as shown in Figure 9-7. The program assumes that the extension of such files is .pmp,

but you may change this by typing your own wildcard combination.

The normal procedure in creating a test set would be to:

1. Create a test well entry by assigning well identification, typing in description, and typing the distance to observation well.
2. Select Measurements Units for time, drawdown, and pumping rate.
3. Select General Data Units.
4. Set Edit Attributes for the test.
5. Input standard ASCII file.

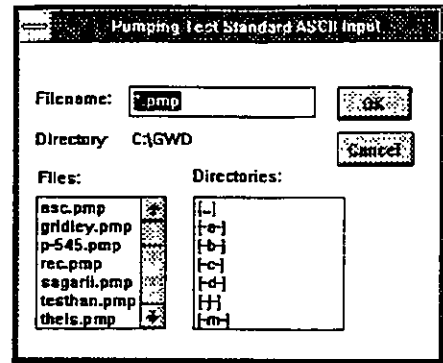

Figure 9-7

- 9.4.5. Standard ASCII Output** This option provides for saving test data that you have entered from the keyboard or that you may have edited. When used, you will be prompted for an ASCII file name. The data are saved in a format which may look as follows:

1.000	0.280	500
2.000	1.040	
3.000	1.775	
5.000	2.956	
10.000	4.894	
15.000	6.142	
20.000	7.059	
25.000	8.158	
30.000	8.720	
45.000	9.346	
50.000	9.674	
55.000	9.967	
60.000	10.230	400
62.000	10.119	
64.000	9.940	
66.000	9.826	
68.000	9.754	
70.000	9.707	
75.000	9.657	
80.000	9.658	
90.000	9.652	
120.000	12.151	

The results of this test are interpreted in the following way. The well was pumped at a constant rate of 500 m³/day in the first 60 minutes. In the second hour the pumping was at a reduced rate of 400 m³/day. The test terminated after two hours of pumping.

9.5. FITTING

The GWW package contains four methods of fitting data: Theis, Jacob, Hantush, and Recovery. This is shown in Figure 9-8. You must not use the recovery method if the data are not prepared for the recovery. You may use either Theis or Hantush on the same set of data and see the difference in fitting.

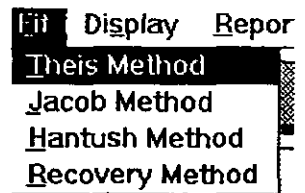

Figure 9-8

Each of the methods works in iterations. The fitting starts with values of transmissivity and storage coefficient as initial guesses calculated using the Jacob's approximation. Since the fit for the Theis method is a two-parameter iterative algorithm (transmissivity and storage coefficient), it is much faster than the Hantush method which is a three-parameter algorithm (transmissivity, storage coefficient, leakance). If, on top of this, you select a partial penetration case, the processing may take several minutes on relatively fast computers (82486 running at 33 MHz).

In rare cases it may happen that there will be no fit in a pre-specified number of iterations (set at 100). This will be the case when test data do not come close to theoretical expectations of a normal leaky or nonleaky aquifer. However, if you notice at the first iteration that the estimation error is labeled with five or more asterisks, your data file is not correct. This will be the case if you have not followed conventions as specified before, you have a blank line in the data file, or, in the case of the recovery method, you have not typed cumulative time.

If the fitting was OK, the results will be typed into the entry form.

9.6. DISPLAY

The display is used for (a) viewing field data before fitting, and (b) displaying the fit.

You may wish to view the test data to check for errors in typing or measurements. Time data will be OK since the editor will warn if some input data lines are out of time sequence. But the drawdown data may be mistyped or behave erratically. In that case the fit will not make sense unless you modify the data. One of displays of field data is shown in Figure 9-9 before the fit.

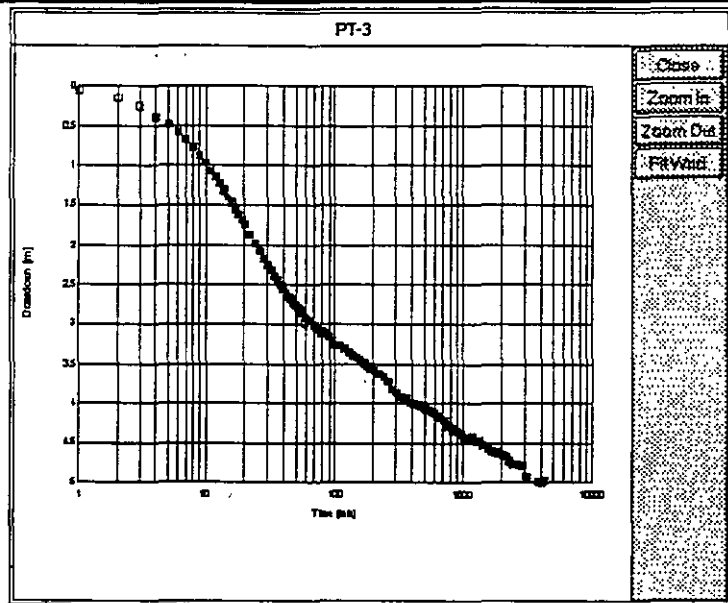

Figure 9-9

Before accepting the results, you will want to see how data are fitted. After you select the option Display you are asked to select one of three patterns (see Figure 9-10):

- time at logarithmic scale, draw-down at linear scale;
- time and draw-down at logarithmic scale;
- time and drawdown at linear scale.

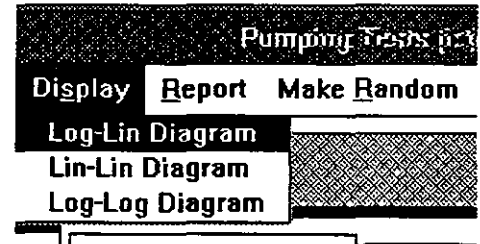

Figure 9-10

Notice that the printout will always be in semilogarithmic scale. One of fitted semilogarithmic displays is shown in Figure 9-11 for the Hantush fitting method. Notice the difference of display for points that have been skipped. On the color screen this is even more obvious.

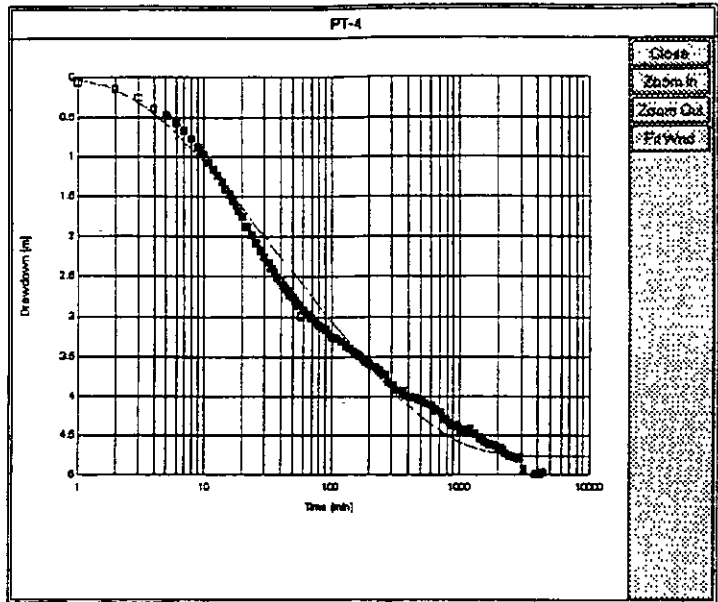

Figure 9-11

9.7. REPORTING

By selecting the **Report** option from the menu bar you may print the following:

- Fit graph showing field or measured data and the fitted curve, along with results and other information that you selected to put on the report form.
- A table for a single well displaying measured data, fitted data, the difference between the two, time, pumping rates, and any other parameter that you decided to put on the reporting form.
- A table for all wells making the data base or working set displaying some general data such as wells' identifications, descriptions, coordinates, elevations, transmissivities, storage coefficients, leakance, etc.

The submenu for reporting is as shown in Figure 9-12. If you select the upper option, Print Fit, the standard reporting form will be used including some general information about the well, test results, methods of fitting, and the diagram. This standard form, which is a part of

the data base template GWW.000, is prepared for the following units:

- Transmissivity in m^2/day .
- Drawdowns, aquifer thickness, distances and geometry of test wellfield setup in meters.
- Time in minutes.
- Leakage in day^{-1} .
- Pumping rate in m^3/day .

You may need to modify this form for another set of units. [The modification is done using **Tools** from the main menu, followed by **Report Forms Editor**, then **Pumping Tests**, and **Single Record Form, File, Old, Standard form.**]

If you select the option **Print Fit**, you will not be prompted to select a reporting form.

Similarly, using the option **Print General Data Table** the standard report form will be assumed, and you will not be given the chance to replace it with another form that you may have created.

The middle two options are used to first select a reporting form, and second to print the form. **Select Fit Form** is intended to print a report that is prepared for a single well, and **Select Table Form** is intended to print a report that is prepared for all wells in the working set.

In the GWW.000 template data base, three reporting forms have been prepared by programmers to report fitted data. When you select the option **Select Fit Form** you will be asked to choose from the list of forms as shown in Figure 9-13. The 'PartialPenetration' form refers to a

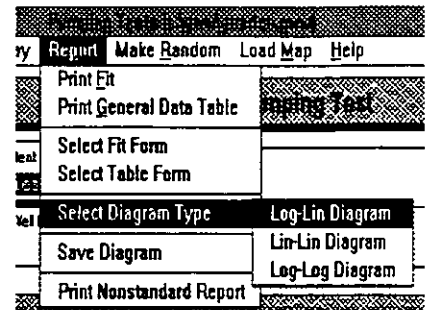

Figure 9-12

pre-designed form which reports all information about the test setup. The Standard form should be used for fully penetrating wells. It will report either Theis, Han-

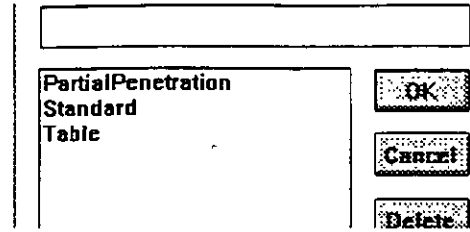

Figure 9-13

tush, or recovery methods depending on the fitting method selected. This form is prepared with metric units. Modify it if you wish to use another system of units.

The **Table form** will report the single well test data in columns with time intervals, measured and fitted draw-downs, drawdown differences, pumping rates etc. One column will also show whether a point was skipped or included into the fit.

For each type of reporting, whether for single test or for all tested wells, you may create more than one reporting form. When you create such forms using Report Form Editor from the Tools menu, you should save them using Save As .. option, and assign an internal file name. When the Select Fit Form or Select Table Form option is invoked, all these forms will be listed for you to choose from.

You may use the option **Select Diagram Type** to print the test data using one of three types, as shown in Figure 9-12.

Save Diagram is used to save the currently displayed diagram for printing using the **Nonstandard Report** option. As in other applications, you will be prompted to save the graph under a name, and to decide on the diagram size.

9.8. **MAKE RANDOM**

This routine is explained in more details in Chapter 5, Section 5.6. The program will allow you to select any one

of space distributed numeric parameters available for this application, including some that may have no meaning for contouring (such as e.g. average pumping rate, geometrical parameters referring to the position of pumping and observation well screens, etc.). Normally what you will want to prepare for contouring will include transmissivity, hydraulic conductivity (if you decide to keep this parameter in data base), saturated thickness of aquifer, etc. You should exercise caution in what to contour. Hydrogeological parameters such as storage coefficient, specific yield, and leakance are usually known at occasional points within a large ground water system. It would make more sense to assign different zones with distinct values of such parameters, rather than smoothly changing contour lines implying changes at every point. The random variable offering may look as shown in Figure 9-14.

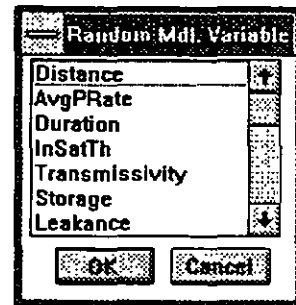

Figure 9-14

9.9. LOAD MAP

This option is explained in details in Chapter 5, subsection 5.3.2. It is used to select a working set, or individual wells to work with, directly from a map.

9.10. HELP

This is context-sensitive on-line help which guides you through various options and procedures.

9.11. EXAMPLE

EXAMPLE FIVE

In this example you will create a pumping test entry, use the editor, fit the Theis curve to data, display the test and print results. The test data are taken from DeWiest's book *Geohydrology*, 1965, page 264-266. The author assumes that this test is a good example of a nonleaky aquifer. The example is as follows:

A completely penetrating well is pumped at a constant rate of 500 gpm. Drawdowns during the pumping period are measured in an observation well 150 ft from the pumped well, at times varying from 2 min to 6 hr. They are recorded in the table below.

Time (min)	Drawdown (ft)	Pumping Rate (gpm)
0	0	500
2	1.2	
3	1.9	
4	2.45	
5	2.9	
6	3.35	
7	3.65	
8	4.1	
10	4.6	
14	5.5	
18	6.15	
24	7	
30	7.75	
40	8.5	
50	9	
60	9.5	
80	10.05	
120	10.3	
180	10.5	
240	10.65	
360	10.8	

The procedure is as follows.

1. From the main menu bar in the GWW select **Applications**.
2. Select **Pumping Tests**.
3. Select **Data**, and click on **General Data Units**. When the window **Change Units for ...** is displayed click on **Distance**, confirm with **OK** and select feet, then click on **AvgPRate**, again **OK** and select gpm, then click on **Duration** and select minutes. Click on **Transmissivity** and select gpd/ft. Select **StandardError** and select feet. Click on **OK** to return to the Data menu.
4. Type DW-1 in the Well Ident field, press TAB; type Example from DeWiest's book, 1965, p.264-266 in the Description field, press TAB; type 150 in the Distance field; press TAB.
5. Notice that the well list contains the well number DW-1. Click with mouse on DW-1 in the well list window.
6. Select **Edit**, followed by **Measurements Units**. Click on **Time** and select minutes. Repeat the procedure (Edit, Measurements Units) and select **Drawdown**. Click on feet. Repeat once again, select **Pumping rate** and select gpm.
7. Go once again to **Edit** and select **Edit Attributes** to confirm that the Confined Aquifer box is crossed (if not click inside the box), and that Partial Penetration box is empty.
8. From Edit menu select **Edit Measurements**. Check that the time is in min, drawdown in ft, and pumping rate in gpm.
9. Start typing. Type 0 in Time column, press TAB, type 0 in Drawdown column, press TAB; type 500 in Pumping Rate column, press TAB twice. The cursor should be in first column of the line two.
10. Type 2 in Time column, press TAB; type 1.2 in Drawdown column, press TAB; press TAB twice to move to the line 3. Type 3, press TAB; type 1.9, press TAB; press TAB twice more to move to the next time interval.



11. Type 4, press TAB; type 2.45; press TAB three times.

12. Keep typing until the last line, type 360 in Time column, press TAB; type 10.8 in Drawdown column. Stop here. The screen should display as shown in Figure 9-15. Instead of pressing TAB save the table by holding down the CTRL key and pressing S (for save).

DW-1			
Time(min)	Depth (feet)	Q (gpm)	Skp
0	0	500	
2	1.2		
3	1.9		
4	2.45		
5	2.9		
6	3.35		
7	3.65		
8	4.1		
10	4.6		
14	5.5		
18	6.15		
24	7		
30	7.75		
40	8.5		
50	9		
60	9.5		
80	10.05		
120	10.3		
180	10.5		
240	10.65		
360	10.8		

13. You are back in the application's main menu. Select Display to look at what you just typed. Select Log-Lin Diagram. The screen's display should look as shown in Figure 9-16.

Figure 9-15

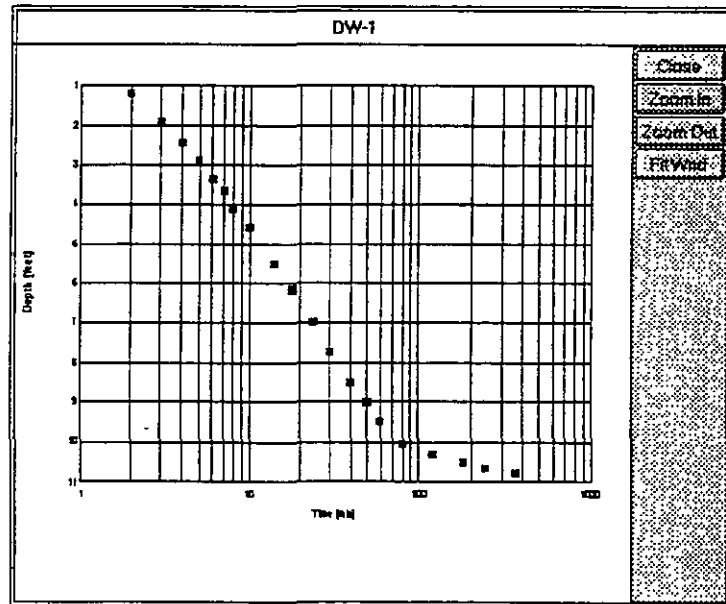

Figure 9-16



14. Click on **Close** on the right side to remove the display.
15. Select **Fit**, followed by **Theis Method**. Wait until the results are displayed. The screen should look as shown in Figure 9-17. Notice the results:

Pumping Test			
Well Ident 04-2	Description Example from DeWiest's book, 1965, p.264-266		
Obs. Well Distance 150.00	Average Pumping Rate 500.0000	Duration 360.0000	Initial Saturated
Results			
Transmissivity 27175.77	Storage Coefficient 0.0002952360	Leakance	Estimate Error
Fit Method		Theis Method	

Figure 9-17

- Transmissivity = 27,175.74 gpd/ft
 - Storage coefficient = 0.000295
 - Estimate Error = 0.67 ft.
16. Select **Display**. Select **Log-Lin Diagram**. The fitted curve is as shown in Figure 9-18. Not too good!
 17. Print results by selecting **Report** and **Print Fit**.
 18. Check whether this may be a leaky aquifer case. First remove the diagram from the display by clicking on **Close**.
 19. Select **Fit** followed by **Hantush method**. Wait until the processing is finished and notice the results:
 - Transmissivity: 16,177.67 gpd/ft
 - Storage coefficient = 0.00043
 - Leakance = 0.00616 1/day



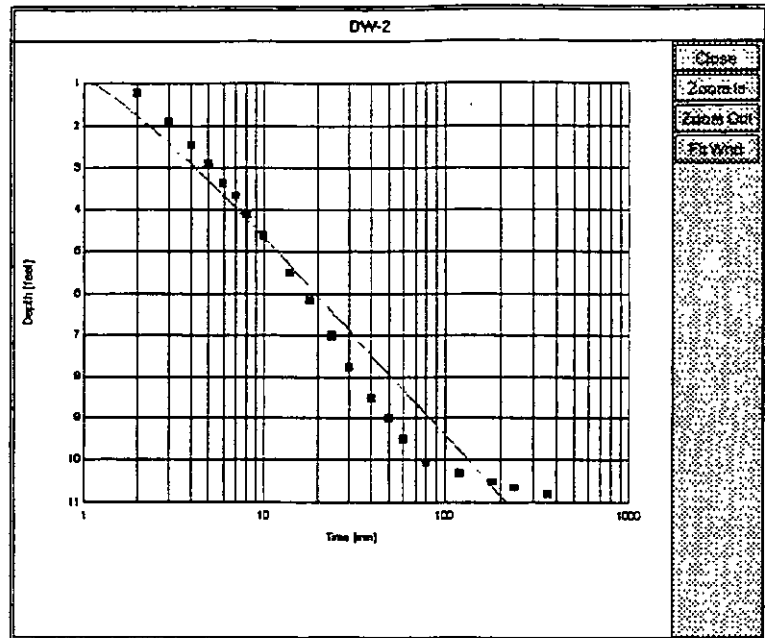

Figure 9-18

- Error estimate = 0.14 ft.
20. Look at the fit. Select Display, followed by Log-Lin Diagram. The display is as shown in Figure 9-19. Notice that the fit is much better. You do not need to look at the display. The comparison of Error estimates is sufficient to tell you which method fits better.

Finally compare the results from the book with these results. Transmissivity in the book is equal to 20,500 gpd/ft, storage coefficient is equal to 0.000315. While storage coefficients are of about the same order of magnitude, the "nonleaky" transmissivity is overestimated for about 26%. It appears that the aquifer is less transmissive, but a portion of pumped water is supplied from leakage.

This ends the example.



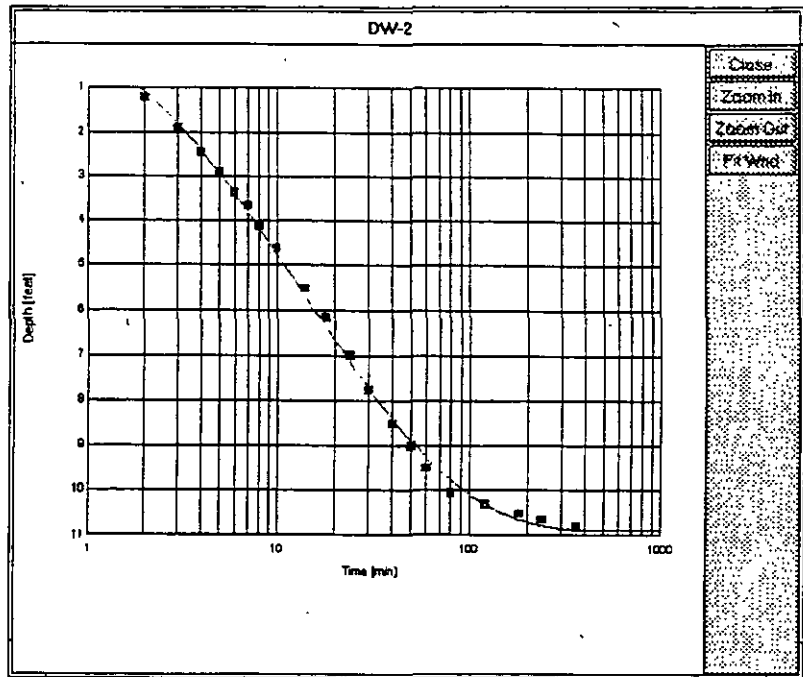

Figure 9-19

This page intentionally left blank.

10.1.INTRODUCTION**10.1.1. General**

Using the Hydrographs application from the main menu of the GWW software you may do the following:

1. Create a data base containing information about water levels in observation, monitoring or pumping wells.
2. Switch between water levels in absolute elevations and depth to water table from a measuring point.
3. Display measured water level data for the whole or a selected period of observation. Connect all water level points in the data base or select a "connection" span, leaving "unconnected" points as random points on the hydrograph.
4. Print the results in hydrograph forms with general data on wells as a header and one or more graphs and location maps.
5. Interpolate water levels, or depths to water table, for any date within the period of observation. Prepare water level (or depth to water) data for contouring.
6. Prepare water level (elevation) lines to be displayed on hydrogeological cross sections.

**10.2. MAIN MENU
BAR****10.2.1. Components
of the
Hydrograph
Application**

As shown in Figure 10-1, the major options on the application's menu bar are the following:

- Data
- W.Levels (abbreviated Water Levels)
- Display

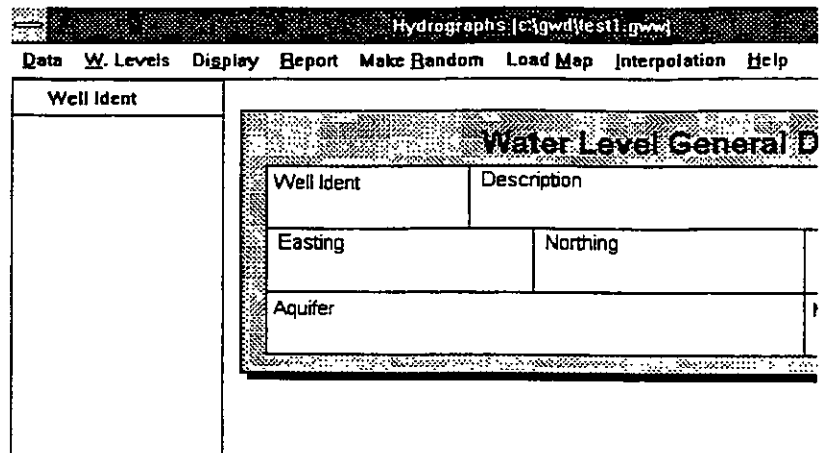

Figure 10-1

- Report
- Make Random
- Load Map
- Interpolation
- Help

Each of these options, except options **Make Random** and **Load Map**, is explained in detail in this Chapter. **Make Random** is discussed in Chapter 5, Section 5.6; **Load Map** is discussed in Chapter 5, Section 5.3.2.

When the Hydrograph application is selected the display window consists of three main parts:

- Menu bar on the top.
- List of wells on the left currently included in the working set, with two numbers at the top referring to the number of such wells making the current working set and the total number of wells with water level records in the data base.
- Entry form with information on the first well on the list or an empty form for a new data base.

If you are creating a new data base with observation/monitoring wells, the left window will be empty, and the number of wells will be zero. This is the case as

shown in Figure 10-1. Figure 10-2 displays a case with many wells already in the data base.

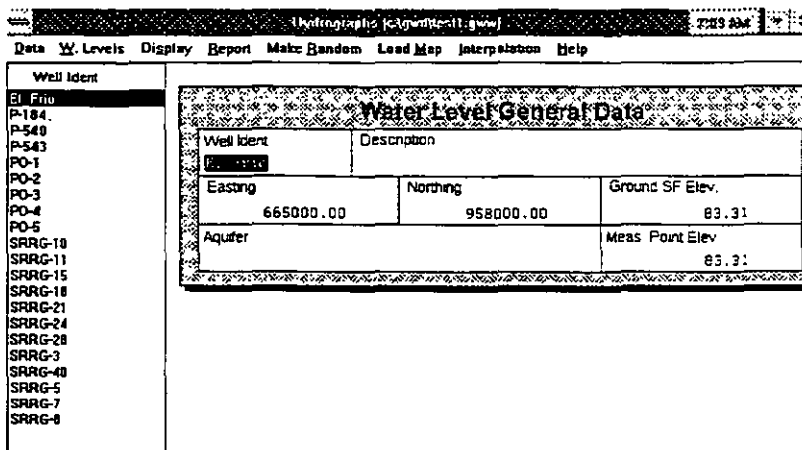

Figure 10-2

10.2.2. Entry Form

In the Entry Form as shown in Figure 10-1 and 10-2 you may type the input into all or selected fields. The only field specific to this application is 'Aquifer'. All other fields are copied from the Master data structure and Master data application. However, you may decide to type coordinates and elevations in this entry form and not in the entry form of the Master data application. It is up to you to decide which application to use for information that is "exchanged" between applications.

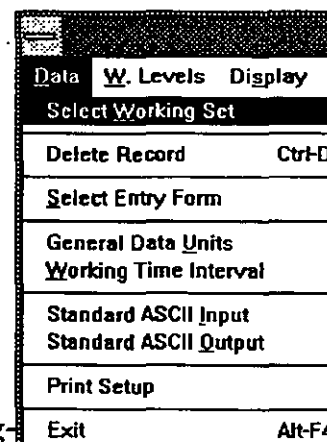

Figure 10-3

10.3.
DATA

10.3.1. Options on the Data Menu

The Data menu is shown in Figure 10-3. The following options are available:

- Select Working Set.
- Delete Record.
- Select Entry Form.
- General Data Units.
- Working Time Interval.
- Standard ASCII Input.
- Standard ASCII Output.
- Print Setup.
- Exit.

10.3.2. Select Working Set

You use **Select Working Set** option in the same manner as in any other application. Its use is explained in Chapter 5, Section 5.3. Its purpose is to reduce a large set with many wells to a smaller set of wells which may be selected for whichever reason.

10.3.3. Delete Record

To delete a record you will do the following:

1. Move the cursor to the well you wish to delete.
2. Select **Data** on the application's menu bar.
3. Select **Delete Record**, or hold down the CTRL key and press D key.
4. A warning will be displayed giving you a chance to reconsider.

10.3.4. Select Entry Form

You may use the default form as displayed in Figure 10-1, or any form that you may have created following the steps explained in Chapter 3. To change the form:

1. Select **Data** on the application's menu bar.
2. Click on **Select Entry Form**.

3. Select the form name which you wish to use as your entry form from the list displayed in the dialogue box as shown in Figure 10-4.
4. Click on OK.

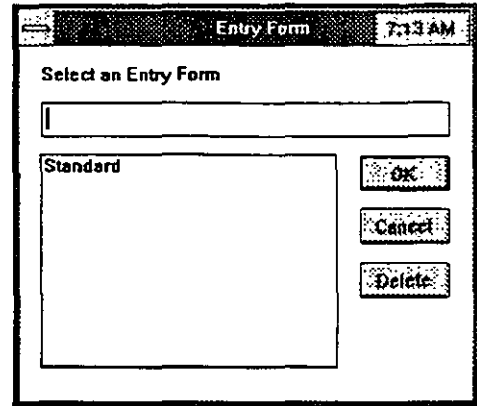

Figure 10-4

In the Hydrographs application it may be desirable to design another entry form with information other than in the standard form. For example, you

may wish to identify a well either as an observation, monitoring or production well. This information may be kept in the Master data application or in the Hydrographs application. You may use this information to select a working set or to display one type of well onto a location map. You may think of other pieces of information to keep in the hydrographs data base, such as the method of measurement (chalk tape, electric line, recorder, logging device, etc.), or the use of the well other than for water level measurement.

10.3.5. General Data Units

When activated, the option **General Data Units** displays a dialogue box such as shown in Figure 10-5. In the GWW data base template, which is used in the example shown in Figure 10-5, the only

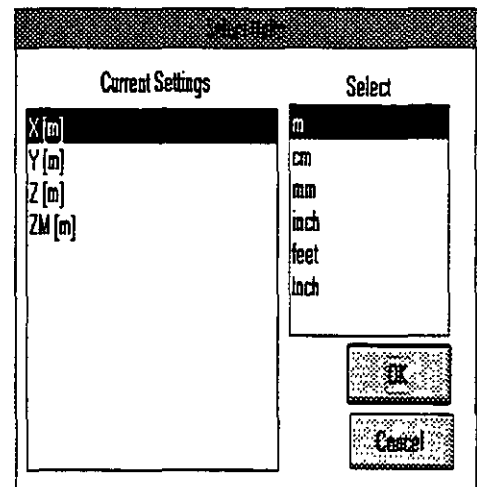

Figure 10-5

space-distributed numerical parameters are coordinates and ground surface and measuring point elevations.

10.3.6. Working Time Interval

The option **Working Time Interval** permits you to reduce a long period of observations to a shorter time span. This is important in editing data, in displaying hydrographs with more detail in a shorter period, and in reporting data for the period of interest. For example, if you are going to use the data base for making a mathematical model of an area, your interest may be in a certain period of time in which you wish to calibrate your model.

For example, if you decide to display and print hydrographs within the period from 1 January 1984 through 31 December 1988, you should proceed as follows:

1. Select **Working Time Interval** from the Data menu. The display prompts you to input the starting year, month and day. Type 1984, press tab, type 1, press TAB, type 1, press TAB. Press TAB twice more to skip hour and minute. The screen should look as shown in Figure 10-6.

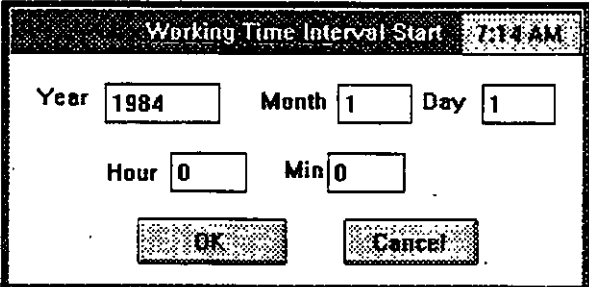

Working Time Interval Start 7:14 AM

Year 1984 Month 1 Day 1

Hour 0 Min 0

OK Cancel

Figure 10-6

2. When the dialogue box titled 'Working Time Interval End' opens type 1988 for the year, 12 for the month,

and 31 for the day. Press twice TAB. The display should look as shown in Figure 10-7.

Working Time Interval End 7:14 AM

Year 1988 Month 12 Day 31

Hour 0 Min 0

OK Cancel

Figure 10-7

- Click on OK to close this dialogue. The whole data set is now reduced to the selected time interval.

10.3.7. Standard ASCII Input

You may save the whole data base, all the wells, in one ASCII data file. In the version 1.0, the input format was made compatible with output format of the UN/GW software. In the version 1.1, that "compatibility" was abandoned in favour of a more "friendly" format.

The ASCII input format is explained in Appendix D. However, if you are in doubt what is the proper format, you should create one example and save it using the option **Standard ASCII Output**. Once saved the file can be examined and the format noted. When the option **Standard ASCII Input** is invoked, the dialogue box will open as shown in Figure 10-8. The program assumes the

Water Levels Standard ASCII Input

Filename: hvd OK

Directory: C:\GWD Cancel

Files: Directories:

Figure 10-8

standard extension for such files .hyd, but you may override this and type any wildcard combination in the file-name field.

10.3.8. Standard ASCII Output

This option is used to save the data base containing water level measurements in a standard ASCII file. Just as in other parts of the GWW package, it is a good idea to save the data from time to time in an ASCII file. Whatever may happen to your data base, you may always re-create it by reading this file as a standard ASCII input. When this command is invoked, the dialogue box will open as shown in Figure 10-9. The program assumes the standard extension for such files .hyd, but you may override this and type any wildcard combination in the file-name field. The extensions are for your convenience.

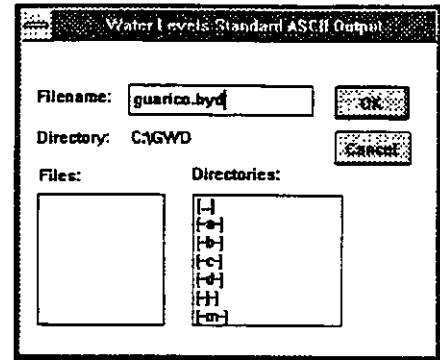

Figure 10-9

10.3.9. Print Setup

The **Print Setup** option is explained in Chapter 5, Section 5.4.

10.4. WATER LEVELS

10.4.1. Edit Water Level Data

Edit Water Level Data is the first option on the **W.Levels** menu, as shown in Figure 10-10.

When you select **Edit W.Level Data** option the edit table is displayed. It may contain data as shown in Figure 10-11, or it may be empty prompting you for input. You enter or edit data using the TAB key, ENTER, or mouse.

The screenshot shows the 'Hydrographs [c:\gwd\test1.g]' window. The 'W.Levels' menu is open, displaying options: 'Edit W. Level Data Ctrl-E', 'Depth Data', 'Level Data', 'Depth/Level Units', 'Insert Row Ctrl-I', 'Delete Row Ctrl-D', 'Save W. Level Data Ctrl-S', and 'Exit (don't save) Ctrl-X'. Below the menu is a table with columns for 'Year', 'Day', 'Month', 'hh:mm', and 'Depth [m]'. The table contains data for points P-184, P-540, P-543, P0-1, P0-2, P0-3, P0-4, P0-5, SRRG-10, and SRRG-11.

Point	Year	Day	Month	hh:mm	Depth [m]
P-184	1984	1	1		11.27
P-540	1984	1	2		11.47
P-543	1984	1	4		12.56
P0-1	1984	1	5		11.42
P0-2	1984	1	6		11.32
P0-3	1984	1	7		11.28
P0-4	1984	1	8		11.18
P0-5	1984	1	9		11.18
SRRG-10	1984	1	10		11.08
SRRG-11	1984	1	11		11.05

Figure 10-10

You may delete a row in the editing table by holding down the CTRL key and simultaneously pressing D. You may insert a row by holding down the CTRL key and simultaneously pressing I. You may save the data by holding down the CTRL key and pressing S. You may quit or exit without saving the data by holding down the CTRL key and pressing X.

10.4.2. Selecting Levels or Depth to Water Level

By clicking on Depth Data on the W.Levels menu you decide to type in the values of depths to water table from a measuring point. The editing table in this case may look as shown in Figure 10-11. Conversely, by selecting

The screenshot shows a table titled 'EI_Frio' with columns: 'Year', 'Day', 'Month', 'hh:mm', 'Depth [m]', and an upward arrow icon. The table contains data for the year 1984, days 1 through 7.

Year	Day	Month	hh:mm	Depth [m]	↑
1984	1	1		11.24	
1984	1	2		12.77	
1984	1	4		12.42	
1984	1	5		12.7	
1984	1	6		12.93	
1984	1	7		13	

Figure 10-11

Level Data you will be prompted to type water levels in absolute elevations above mean sea level. The editing table in this case may look as shown in Figure 10-12.

El_Frio					
Year	Day	Month	hh:mm	Level [m]	↑
1984	1	1		72.07	
1984	1	2		70.54	
1984	1	4		70.89	
1984	1	5		70.61	
1984	1	6		70.38	
1984	1	7		70.31	

Figure 10-12

10.4.3. Depth or Level Units

Although you may have selected meters as a basic unit of length (that is of depth and/or elevation), you may override the default by using the option **Depth/Level Units** on the **W.Levels** menu. The display may look as shown in Figure 10-13 offering a list with all possible length units as read from the **GWV.UNT** file or another file created by you for your data base.

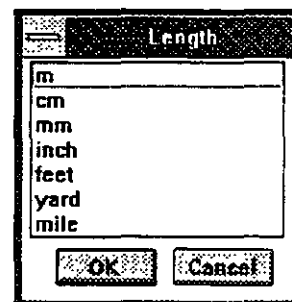

Figure 10-13

10.5. DISPLAY

When you select the **Display** option on the menu bar, a portion of the hydrograph for the currently selected well will be displayed within the specified time interval using the option **Working Time Interval**. The hydrograph may look as shown in Figure 10-14. All points will be connected since the default connecting interval is very large, 365 days.

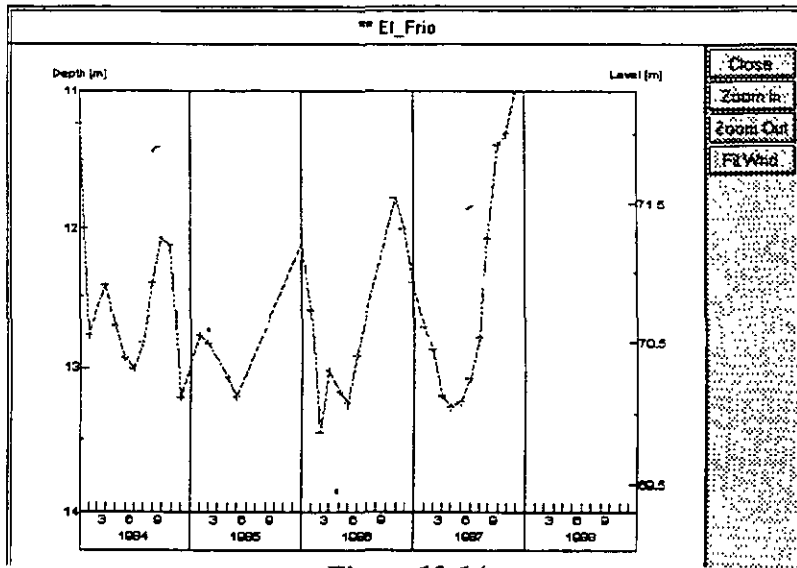

Figure 10-14

10.6. REPORTING

When you select the **Report** option from the menu bar the display looks as shown in Figure 10-15.

As in other applications, if you select printing options in the upper part of the submenu the program uses standard reporting forms.

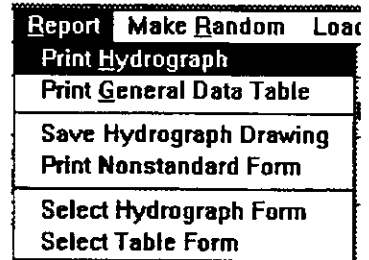

Figure 10-15

The difference between **Print Hydrograph** and **Print General Data Table** is as follows. **Print Hydrograph** prints one hydrograph for a single well. There will be a header with identification data, followed by the graph. [You may place a location map on the same reporting form. For this you need to (a) create such a map using the Map application, (b) modify the standard reporting form or create another form which will have a drawing field with the name of the map.]

General Data Table option is intended to print a report that is prepared for all wells in the working set. The data consist of well identification, description, coordinates, and elevations.

Using the lowermost two options will permit you to override the standard reporting forms and select an alternative form. An example is shown in Figure 10-16 for the hydrograph form. The reporting forms created in the GWW.000 template, which

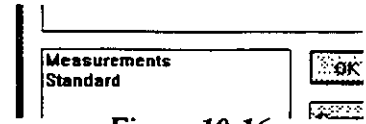

Figure 10-16

are at your disposal without modifications, are **Measurements** and **Standard**. The **Standard** reporting form places a header with general data on a well on the form, followed by the hydrograph drawing field filling the rest of the form. The **measurements** reporting form uses the same header, but instead of the drawing field it presents a table with field measurements for the single well within the selected time interval.

For each type of reporting, whether for a single test or for all tested wells, you may create more than one reporting form. When you create such forms using **Report Form Editor** from the **Tools** menu, you should save them using **Save As ..** option, and assign an internal file name. When the **Select Hydrograph Form** or **Select Table Form** option is invoked, all these forms will be listed for you to choose from.

Save Hydrograph Drawing is used to save the currently displayed hydrograph for printing using the **Print Non-standard Form** option. As in other applications, you will be prompted to save the graph under a name, and to decide on the diagram size.

10.7.MAKE RANDOM

This routine is explained in more detail in Chapter 5, Section 5.6. The program will allow you to select any one of space distributed numeric parameters available for this application, including some that may have no meaning

for contouring (for example the elevation of the measuring point). This routine is used mainly to create a location map showing only wells which make the water level data base, or wells which have a more or less continuous water level measurement record.

10.8. LOAD MAP

This option is explained in detail in Chapter 5, subsection 5.3.2. It is used to select a working set or individual wells with which to work directly from a map.

10.9. INTERPOLATION

This is one of very important options in the hydrograph application. It permits you to create a contour map for any date within the time interval for which you have data. It also permits you to decide on the spanning time interval in which you wish to have individual points on a hydrograph connected. The submenu of the Interpolation option is shown in Figure 10-17.

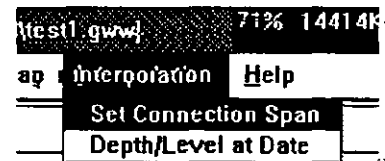

Figure 10-17

10.9.1. Connection Interval

When you select Set Connection Span the display will prompt you to replace the default, which is 366.00 (days), with another interval. The display is as shown in Figure 10-18. For example, selecting 31 days, which implies that only neighboring points observed in less than 31 day intervals, will be con-

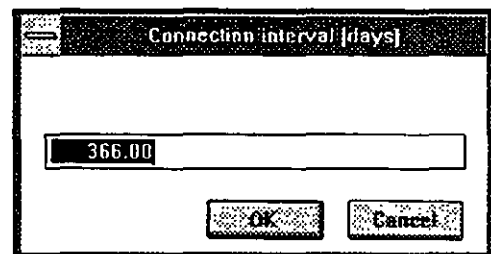

Figure 10-18

nected with a solid line. If the span between two neighboring points is greater than 31 days, they will be displayed as scattered points, as shown in Figure 10-19.

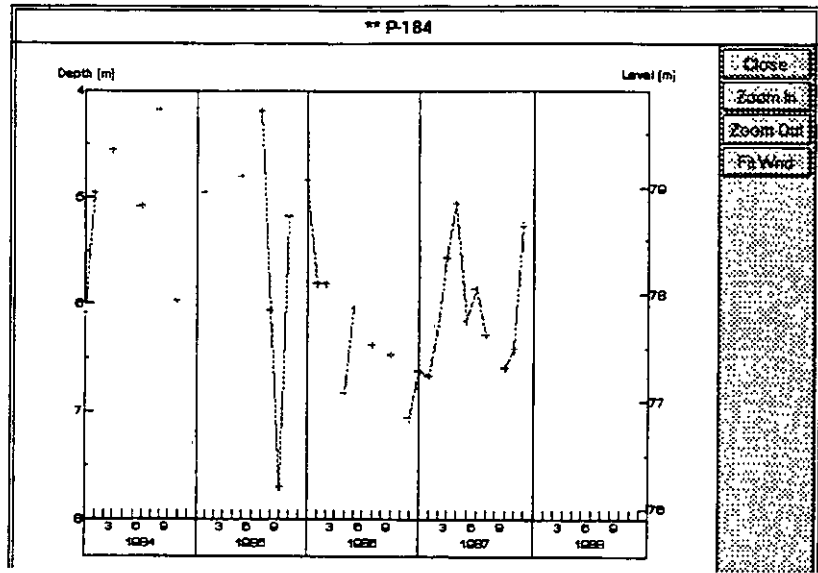

Figure 10-19

10.9.2. Interpolation Date

Using this option you can create a data set ready for contouring at a certain date. You are prompted for the date as shown in Figure 10-20. The option incorporates the make random option from

Figure 10-20

other applications and set a specific date for which you wish to create the contour map. Depending on your type of data, depth to water or water levels in absolute elevations, you will be prompted for 'Save Random Model of Water Depth' as shown in Figure 10-21 or 'Save Random Model of Water Level'.

You may create more than one contour map of water levels. You need to select the option

Depth/Level at Date several times assigning each time another date and labeling the random models to be created with different names.

Examples could be `Level_July_84`, `Depth_Sep_87`, etc. You should follow the convention that internal file names may be long but continuous. You may use points or underscores to separate parts of the file name that have meaning to you.

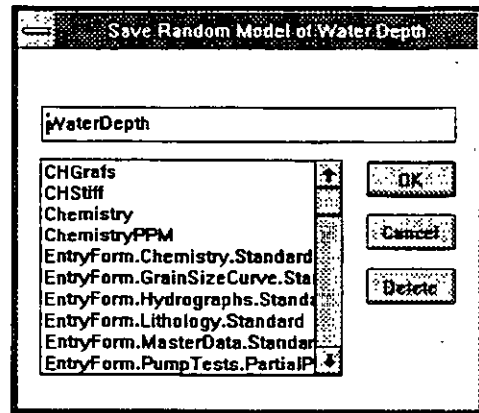

Figure 10-21

10.10. HELP

This is context-sensitive on-line help which guides you through various options and procedures.

10.11. EXAMPLE

EXAMPLE SIX



In this example you will create a water level entry, use the editor, create random models for water levels on 1 June 1991 and depths to water table on 15 December 1991. You will display and print the graph setting the maximum connection interval to 30 days.

The well's general data are the following:

- Well name: SRRG-12
- Description: Observation well in Irrigation System of Rio Guarico.
- Coordinates: X=629000, Y=942000

- Ground Surface Elevation: Z=85.50 m
- Measuring Point Elevation: 86.20 m
- Measurements:

Time Depth to water

1/1/91	12.5
1/20/91	13.1
2/19/91	13.6
3/15/91	13.9
4/29/91	14.2
5 /16/91	14.7
6 /14/91	14.3
7 /12/91	13.9
8 /28/91	13.3
9 /16/91	12.9
10/14/91	12.6
11/11/91	12.3
12/06/91	12.1
12/28/91	11.8

The procedure is as follows.

1. Select **Applications** on the main menu bar of the GWW package.
2. Select **Hydrographs**. The display is as shown in Figure 10-1.



3. Type in Well Ident field 'SRRG-22'. Press TAB.
4. Type in Description field 'Observation well in Irrigation System of Rio Guarico'. Press TAB.
5. Type 629000 in the Easting field, press TAB. Type 942000 in the Northing field. Press TAB.
6. Type 85.50 in the Ground Surface Elevation field. Press TAB.
7. Type Quaternary in the Aquifer field. Press TAB. Type 86.20 in the Measuring Point Elevation field.
8. Press PgDown twice. The cursor is on SRRG-12 in the list of wells.
9. Select **W.Levels**.
10. Select **Edit W.Level Data**. Check that the last column is labeled as Depth [m].
11. Type 1991 in the Year column, press TAB, type 1, press TAB, type 1 press TAB twice. You should be in the Depth column. Type 12.5. Press TAB. You are now on the second line.
12. The program repeats the last year and month. Accept the year as 1991; press TAB to move to the day column. Type 20, press TAB; press TAB again to confirm the month as January; press TAB again to move to the depth column. Type 13.1 and press TAB.

13. Keep typing until the last line: 1991 in the Year column, 28 in the Day column, 12 in the month column, 11.8 in the depth column. The display should look as shown in Figure 10-22.

SRRG-12				
Year	Day	Month	hd. (m)	Depth [m]
1991	1	1		12.5
1991	20	1		13.1
1991	19	2		13.6
1991	15	3		13.9
1991	29	4		14.2
1991	16	5		14.7
1991	14	6		14.3
1991	12	7		13.9
1991	28	8		13.3
1991	16	9		12.9
1991	14	10		12.6
1991	11	11		12.3
1991	6	12		12.1
1991	28	12		11.8

Figure 10-22



14. Hold down the CTRL key and press S to save the data.
15. Select **Interpolation**, select **Connection Span**. Type 30 and select OK.
16. Select **Display**. The display should look as shown in Figure 10-23. If the display shows only a coordinate system, or a frame of a graph but without points and

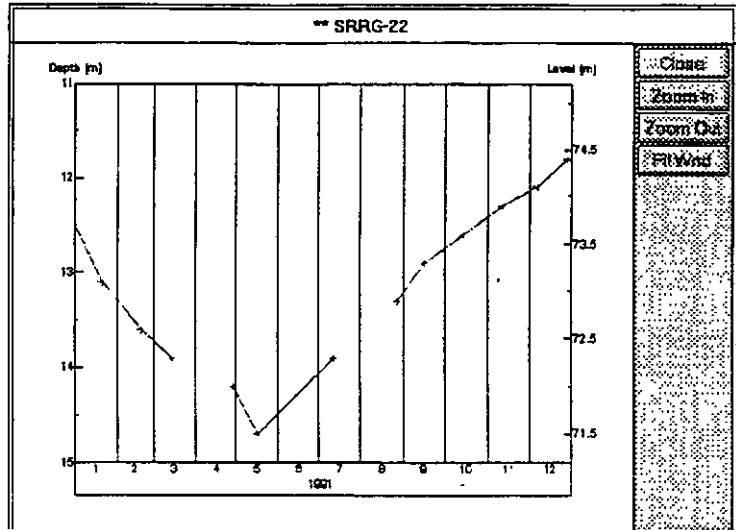

Figure 10-23

lines, you should check which working time interval is currently selected. (Go to **Data**, and select **Working Time Interval**.)

17. Select **Close**.
18. Select **Interpolation**. Select **Depth/Level at Date**. Fill the window prompting you for the interpolation date with the numbers 1991, 12, 15 (15 December 1991).
19. Save the random model under the file name `Depth_15_Dec_91`.
20. Select **W.Levels**. Select **Edit W.Level Data**. Notice that the last column is labeled as `depth [m]`. Select **W.Levels** again. Select **Level Data** to replace `depth` with `level`. Notice that the last column is labeled as `Level [m]` and that the data in this column are no



longer 12.5, 13.1, 13.6, ..., 11.8, but converted to water levels in absolute elevations: 73.7, 73.1, ..., 74.4.

21. Hold down the CTRL key and press X to exit without saving (you have not made any change!).
22. Select **Interpolation**. Select **Depth/Level at Date**. Type 1991, 6, 1 (1 June 1991). Select **OK**.
23. Save the random model of water levels on 1 June 1991 under the name Level_1_June_91.

Using the application Mapping you will create contour maps of depths on 15 December 1991 and levels on 1 June 1991 for this example.

Exit the application by selecting **Data**, and **Exit**.

This page is intentionally left blank.

11.1.1. General

The objective of running a step drawdown test is to obtain information about the performance and efficiency of the well being pumped. The data taken under controlled conditions give a measure of the productive capacity of the completed well and provide data on which the selection of the pumping equipment can be based. The Step Drawdown application is a utility in the GWW package rather than a data base application.

Since this is a test of the productivity of a well, it is often called a well-production test. This is a variable-rate well-production test. A well is pumped at a constant rate for a certain period of time (normally between one and 24 hours) and the drawdown is recorded at the end of the pumping step. The pumping rate is then changed, normally increased, and the well is pumped for the same period of time. The water level is then measured and the drawdown calculated. The same procedure is repeated with different pumping rates one or more times (minimum 3 steps). It is understood that each step must be of the same duration as the others.

Using the Step Drawdown Test application from the main menu of the GWW software, you may do the following:

1. Create a data base containing information about step drawdown test results and efficiency of drilled wells.
2. Display and print step drawdown test results showing two components of the total drawdown: aquifer loss and well loss.

3. Project the step drawdown pumping test results beyond the final step. This is used to forecast the drawdown and/or efficiency if the well will be pumped at a rate about 20% higher than in the test.

11.2. MAIN MENU BAR

11.2.1. Components of the Step Drawdown Test Application

As shown in Figure 11-1, the major options on the application's menu bar are the following:

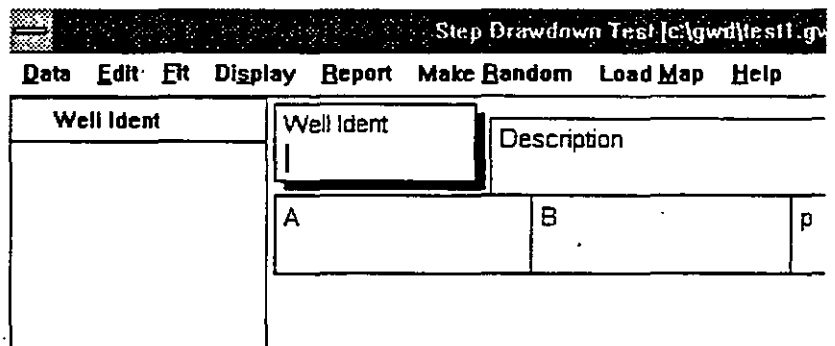

Figure 11-1

- Data
- Edit
- Fit
- Display
- Report
- Make Random
- Load Map
- Help

Each of these options, except options **Make Random** and **Load Map**, is explained in detail in this Chapter. **Make Random** is discussed in Chapter 5, Section 5.6; **Load Map** is discussed in Chapter 5, Section 5.3.2.

When the Step Drawdown Test application is selected, the display window is composed of three main parts:

- Menu bar on the top.
- List of wells on the left currently comprising the working set, with two numbers at the top referring to the total number of wells with step drawdown tests in the data base and the number of such wells in the current working set.
- Entry form with information on the first well on the list or an empty form for a new data base.

If you are creating a new data base with production or test wells, the left window will be empty, and the number of wells will be zero. This is the case as shown in Figure 11-1.

11.2.2. Entry Form

In the **Entry Form** as shown in Figure 11-1 you may input data into two fields: Well Ident and Description. All other fields are used to report results. The coefficients A and B are the coefficients used to fit the drawdown and pumping rate equation (see 11.5).

11.3. DATA

11.3.1. Options on the Data Menu

The **Data** menu is shown in Figure 11-2. The following options are available:

- Select Working Set.
- Delete Record.
- Select Entry Form.
- General Data Units.
- Print Setup.
- Exit.

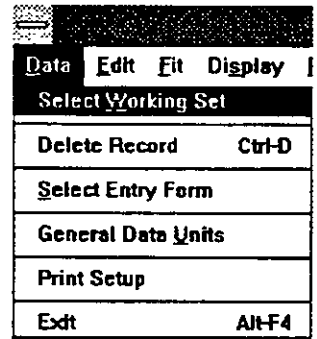

Figure 11-2

-
- 11.3.2. Select Working Set** You use the **Select Working Set** option in the same manner as in any other application. Its use is explained in Chapter 5, Section 5.3. Its purpose is to reduce a large set with many wells to a smaller set of wells which may be selected for any reason.
- 11.3.3. Delete Record** To delete a record you will do the following:
1. With the mouse cursor, select the well you wish to delete.
 2. Select **Data** on the application's menu bar.
 3. Select **Delete Record**, or hold down the CTRL key and press D key.
 4. A warning will be displayed giving you a chance to reconsider.
- 11.3.4. Select Entry Form** You may use the default form as displayed in Figure 11-1, or any form that you may have created following the steps explained in Chapter 3. To change the form:
1. Select **Data** on the application's menu bar.
 2. Click on **Select Entry Form**.
 3. Select the form name from the list displayed in the dialogue box.
 4. Click on **OK**.
- In the step drawdown test application you may think of typing and storing additional information such as pumping equipment, date of test, use of well, maintenance information, etc., if you have not entered this into the Master data entry form.
- 11.3.5. General Data Units** When activated, the option **General Data Units** displays a dialogue box such as shown in Figure 10-5. In the GWW data base template, which is used in the example

shown in Figure 10-5, the only space-distributed numerical parameters are coordinates and ground surface and measuring point elevations. This information is taken from the Master Data application.

11.3.6. Print Setup

The Print Setup option is explained in Chapter 5, Section 5.4.

11.4.

EDIT DATA MENU

11.4.1. Edit Data Submenu

Before you can create a data set or edit data you must type in the well identification number (Well Ident), and its description. If this is already a well which has been entered into the GWW system from another application, the description field should be automatically filled in with information typed elsewhere. In that case the only entry necessary is the well identification. The display then looks as shown in Figure 11-3. The well is used in the Pumping test application and is already in the GWW system.

Step Drawdown Test (c:\gww)	
Data Edit Fit Display Report Make Random Load Map	
Well Ident	Description
PT-1	Todd's book, pa
	A B

Figure 11-3

Only when you select **Edit Data** and open the data table with two columns, drawdown and pumping rate, will you be able to use other options on the edit data menu. These options are shown in Figure 11-4 and are used for editing the table (inserting or deleting rows) and saving data.

11.4.2. Measurements Units

You may select units other than the default for drawdowns and pumping rates. To change the unit for drawdown from m to ft:

1. Select **Edit**.
2. Select **Measurements Units**. The display is as shown in Figure 11-4.

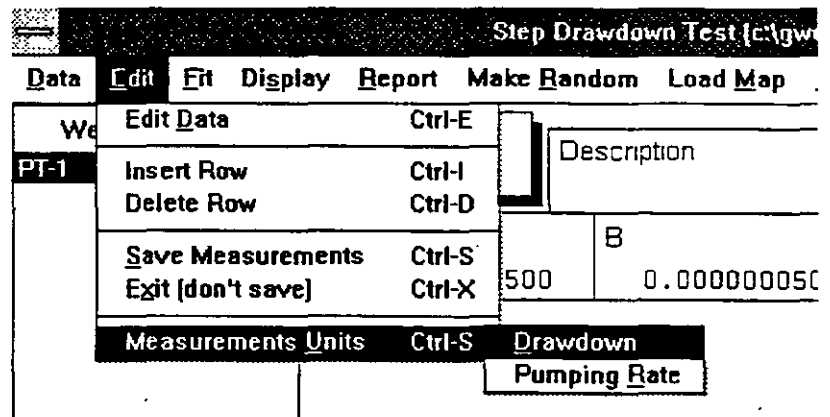

Figure 11-4

3. Select **Drawdown**. The dialogue box lists all units for length that are contained in the GWW.UNT file or that have been created by you for this particular data base.
4. Click on feet and select **OK**.

11.4.3. Entering Data

When you select **Edit Data** a two-column table will be displayed with the cursor in the first row of the drawdown column. Check the units displayed for the drawdown and pumping rate. Type the drawdowns and

corresponding pumping rates. For the fitting algorithm to work correctly you are expected to type drawdowns in increasing order, with the difference between drawdowns being progressively larger for equal multiples of the pumping rate. In other words, if you have tested the well at rates 1000, 2000 and 3000 m³/day, the correct values of drawdowns would be 1.00, 2.10, and 3.40. It would not be correct to have the drawdown values such as 1.00, 1.90, 2.4. The reason is that the specific capacity of the well, which is defined as its pumping rate or yield per unit of drawdown, must be decreasing with an increased pumping rate. In the "correct" case the specific capacities are 1000, 952, 882 m³/day/m; while in the second case the sequence is 1000, 1053, 1250 m³/day/m. In the second case when you select one of fitting methods, the program will display an error message "Unable to fit. Check your data."

You must not press TAB at the end of data entry. If the fifth step as shown in Figure 11-5 was the final test step (drawdown 6 m; pumping rate 5000 m³/day), the cursor must remain after the number 5000. You will save data by either selecting Edit and clicking on Save measurements or by holding down the CTRL key and pressing S.

PT-1	
Drawdown (m)	Pumping Rate
1	1000
2.1	2000
3.3	3000
4.6	4000
6	5000

Figure 11-5

If you do press TAB at the end of data entry and the new line is opened, you must delete this line by holding the CTRL key and pressing D. After that you should save the data in one of two ways as explained above.

11.5.

FITTING

According to classical theory, the total drawdown in a production well has two major components: the drawdown s_a (aquifer loss) due to laminar flow of water

through the aquifer toward the well and s_w (well loss) due to the turbulent flow of water through the screen or well face and inside the casing to the pump intake. Other components, such as additional drawdown due to the partial penetration of an aquifer, or the drawdown due to barrier boundaries of the aquifer or the build-up due to recharge boundaries of the aquifer, are normally contained within the aquifer loss.

According to Jacob (*"Radial Flow in a Leaky Artesian Aquifer,"* Trans.Am.Geophys.Union, vol.27,no.2, 1946), well loss may be represented approximately by the following equation:

$$s_w = BQ^2$$

where

$$s_w = \text{well loss, [L]}$$

$$B = \text{well-loss constant, [T}^2\text{/L}^5\text{]}$$

$$Q = \text{discharge, [L}^3\text{/T].}$$

Aquifer loss, s_a , is linearly proportional to the pumping rate, i.e.

$$s_a = AQ$$

Thus, the equation of total loss during pumping may be written as

$$s = AQ + BQ^2$$

The coefficient A has dimensions of TL^{-2} .

The second theory, presented by, among others Rora-baugh (*"Graphical and theoretical analysis of step-drawdown test of artesian well,"* Proc.Am.Soc.Civ.Eng. 79, separate no.362, 23 pp, 1953) and Karanjac (*"Well Losses due to Reduced Permeability around Well Screen,"* Ground Water, vol.10, 1972) demonstrate that the well loss is not necessarily proportional to the second power of pumping rate. In other words, well losses may be significant although

turbulence may not have developed! The basic formula for well drawdown is

$$s = AQ + BQ^n$$

This is a more general case, of which $n=2$ is an approximation. According to Rorabaugh, n varies according to the aquifer and well situation from less than 2 to 3.5. Values of n less than 2 may occur if Q is relatively low and full turbulence has not yet developed in the entire well-entry flow. For very low values of Q , the flow may even be laminar throughout the system, in which case the well loss coefficient will be zero.

After the data are entered, you should select one of the two fitting methods as shown in Figure 11-6. The computer program then evaluates the coefficients A and B , and writes them into the entry form. The field 'p' will be

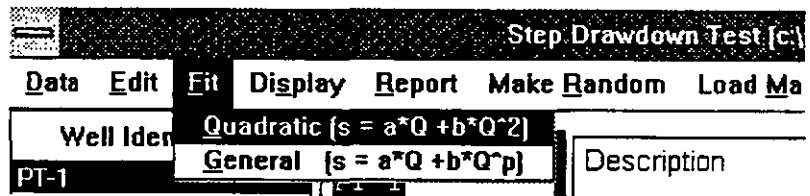

Figure 11-6

also filled with a value, either 2 if the quadratic fit is selected or any value if the more general form is selected.

11.6.

DISPLAY

When you select the **Display** option on the menu bar, the screen may look as shown in Figure 11-7. The upper line defines the aquifer loss, and the lower line defines the total well drawdown. The space under the first line and the abscissa is the aquifer loss, and the space between the two lines is the well loss. On the screen you may assign different colors to each of these two areas to emphasize either of the well drawdown components.

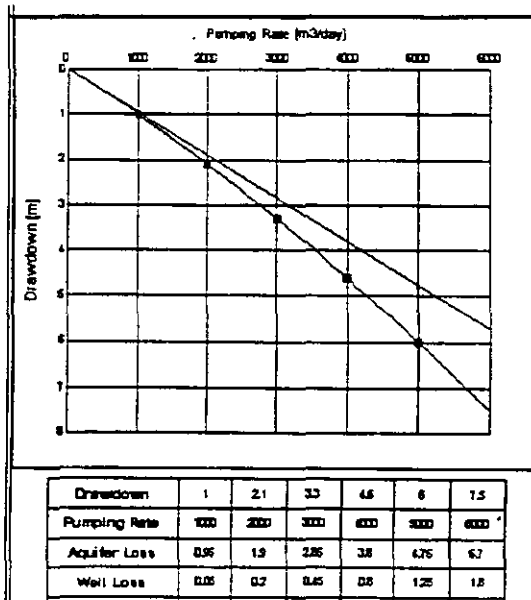

Figure 11-7

The table under the graph reports the measured data (well drawdowns and pumping rates) and each drawdown component from the fit: aquifer loss and well loss. The last line reports well efficiency for each pumping step and for a hypothetical step which assumes 20% higher pumping than the last rate.

The average well efficiency taken as an arithmetic average for all pumping steps is calculated and entered into the entry form. Since the entry form is used for the header of the reporting form, these results will also be printed when the option **Report** is selected.

11.7. REPORTING

When you select the **Report** option from the menu bar, the display looks as shown in Figure 11-8. As in other applications, you may use the stand-

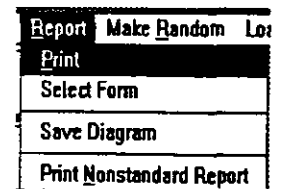

Figure 11-8

ard reporting form (option **Print**) or you may select another reporting form (**Select Form**). In the latter case, a dialogue box will open suggesting the names of all available reporting forms. In Figure 11-9 only the standard form is available, and there is no difference between the two printing options you may select.

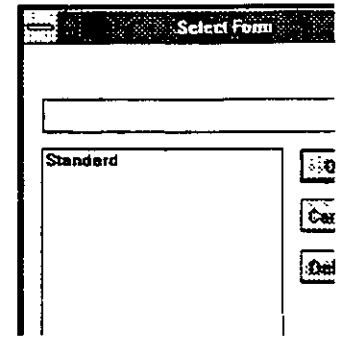

Figure 11-9

Save Diagram is used to save the currently displayed step-drawdown graph for printing using the **Print Non-standard Report** option.

11.8.

MAKE RANDOM

This routine is explained in more detail in Chapter 5, Section 5.6. The program will allow you to select any one of the space distributed numeric parameters available for this application, including some that may have no meaning for contouring (e.g. elevation of the measuring point).

In this application, the list of numeric parameters that may be contoured may look as shown in Figure 11-10, although it is questionable whether most of these will have a meaning. The two parameters that may be used

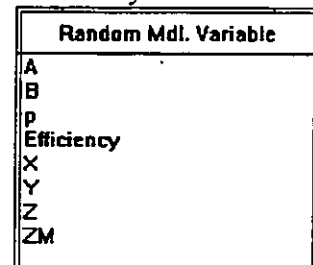

Figure 11-10

are Z (land surface elevation), which should be used for creating a location map with only wells tested with step-drawdown tests, and Efficiency, to show different well efficiencies. You may also add a parameter such as specific capacity of wells to your reporting form, by manu-

ally entering the value obtained from the test and by contouring or displaying this parameter.

11.9. LOAD MAP

This option is explained in detail in Chapter 5, subsection 5.3.2. It is used to select a working set, or individual wells to work with, directly from a map.

11.10. HELP

This is context-sensitive on-line help which guides you through various options and procedures.

11.11. EXAMPLE

EXAMPLE SEVEN

The example from H. Bouwer's book "Groundwater Hydrology," Fig. 4.13, published by McGraw-Hill Book Co. in 1978 will be used. The test data are as follows:



Q (m ³ /day)	1000	2000	4000
Draw-down (m)	4.56	10.74	29.48

The analysis may proceed as follows.

1. Select **Applications** on the main menu bar of the GWW package.
2. Select **Step Drawdown Test**. The display is as shown in Figure 11-1.



3. In the Well Ident field type SDT-1. Press TAB.
4. In the Description field type Bouwer, 1978, Fig. 4.13. Press TAB.
5. Press PgDown twice. The cursor should be on SDT-1 in the list of wells.
6. Select **Edit** followed by **Edit Data**. Check the units for drawdown and pumping rate. If units are not meter for drawdown and m^3/day for pumping rate select **Edit** again and then **Measurements Units**. Select the one you wish to change (drawdown or pumping rate), make the change, and select **OK** to return. Then select **Edit Data** again to open the table.
7. Type 4.56 for first drawdown, press TAB; type 1000 for first pumping rate; press TAB.
8. Type 10.74 for second drawdown, press TAB; type 2000 for second pumping rate; press TAB.
9. Type 29.48 for third drawdown, press TAB; type 3000 for first pumping rate. Do not press TAB. The display is as shown in Figure 11-11. Hold down the CTRL key and press S to save the data.

SDT-1		
Drawdown [m]	Pumping Rate [m ³ /day]	↑
4.56	1000	
10.74	2000	
29.48	3000	

Figure 11-11

10. Select **Fit** and first try the classical Jacob's equation. Select **Quadratic**. The results are immediately written into the entry form.

$$A = 0.0035$$

$$B = 9.8 \times 10^{-7}$$

$$p = 2.00$$



Efficiency (average) = 57%.

11. Select **Display**. The display will look as shown in Figure 11-12.

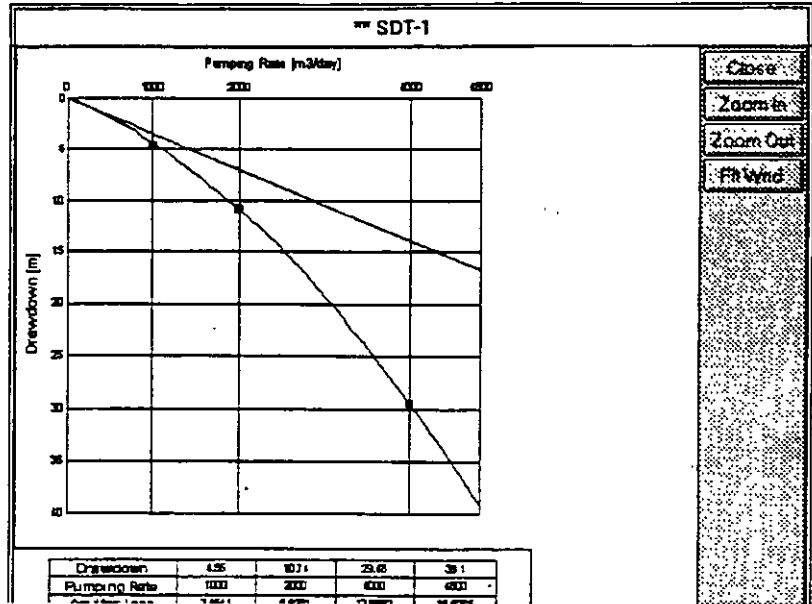

Figure 11-12

12. Try now the second, more general, method. Select **Fit**, followed by **General equation**.

13. To view the results you must first remove the graph from the screen. Select **Close**. Notice that:

$$A = 0.004$$

$$B = 6.8 \times 10^{-8}$$

$$p = 2.31$$

Efficiency (average) = 66%.

You may compare efficiencies and aquifer loss coefficient A, but you cannot compare the well loss coefficients B since they have different dimensions.

14. Select **Display**. The display will look as shown in Figure 11-13.



Exit the application by selecting Data, and Exit.

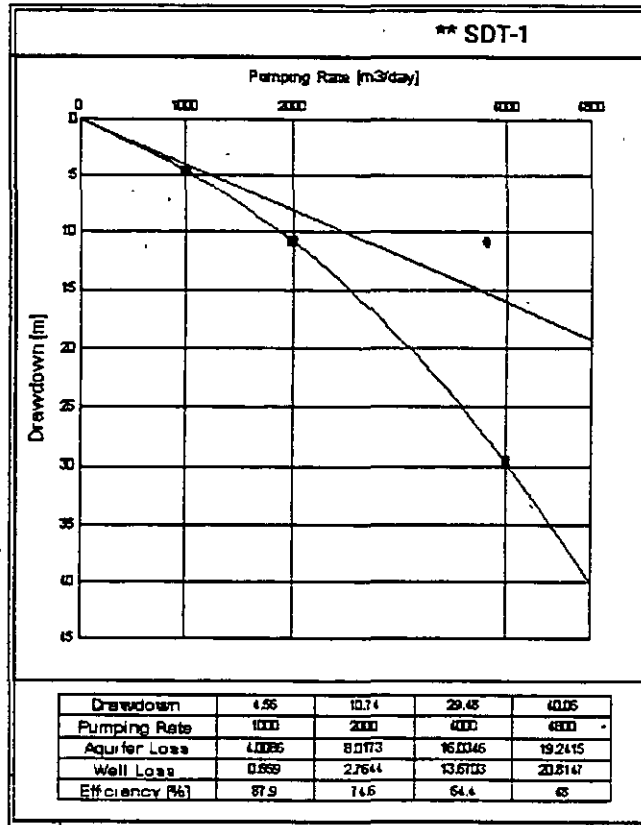

Figure 11-13

This page is intentionally left blank.

**12.1.
INTRODUCTION****12.1.1. General**

This application is a utility for creating and storing information on grain sizes of drilled samples in the data base. With this application you may create a data base, display grain size distribution curves and print one or more curves.

**12.2. MAIN MENU
BAR****12.2.1. Components of
the Grain Size
Curve
Application**

As shown in Figure 12-1, the major options on the application's menu bar are the following:

- Data
- Edit
- Display
- Report
- Load Map
- Help

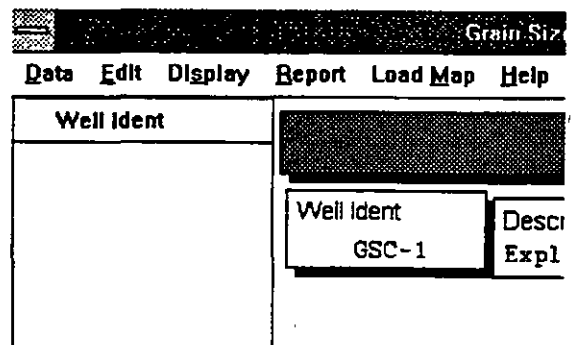

Figure 12-1

The options **Data**, **Edit**, **Display**, and **Report** are explained in this Chapter. **Load Map** is discussed in Chapter 5, Section 5.3.2.

When the Grain Size Curve application is selected, the display window is composed of three main parts:

- Menu bar on the top.
- List of wells on the left currently comprising the working set, with two numbers at the top referring to the total number of wells with grain size samples in the data base and the number of such wells in the current working set.
- Entry form with information on the first well on the list or an empty form for a new data base.

If you are creating a new data base with production or exploration wells, the left window will be empty, and the number of wells will be zero. This is the case as shown in Figure 12-1.

12.2.2. Entry Form

In the Entry Form as shown in Figure 12-1 you may input data into two fields: Well Ident and Description.

12.3. DATA

12.3.1. Options on the Data Menu

The Data menu is shown in Figure 12-2. The following options are available:

- Select Working Set.
- Delete Record.

- Select Entry Form.
- General Data Units.
- Print Setup.
- Exit.

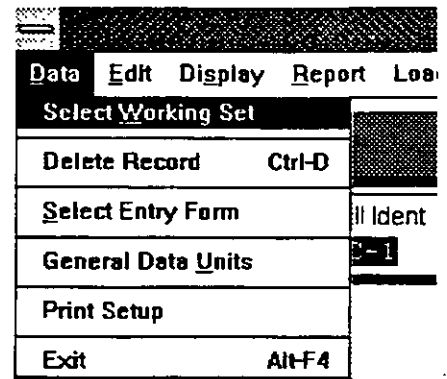

Figure 12-2

12.3.2. Select Working Set

You use the **Select Working Set** option in the same manner as in any other application. Its use is explained in Chapter 5, Section 5.3. Its purpose is to reduce a large set with many wells to a smaller set of wells which may be selected for any reason.

12.3.3. Delete Record

To delete a record you will do the following:

1. With the cursor, select the well you wish to delete.
2. Select **Data** on the application's menu bar.
3. Select **Delete Record**, or hold down the CTRL key and press D key.
4. A warning will be displayed giving you a chance to reconsider.

12.3.4. Select Entry Form

You may use the default form as displayed in Figure 12-1, or any form that you may have created following the steps explained in Chapter 3. To change the form:

1. Select **Data** on the application's menu bar.
2. Click on **Select Entry Form**.
3. Select the form name from the list displayed in the dialogue box.

4. Click on OK.

In the grain size curve application you may think of typing and storing additional information such as uniformity coefficient, d_{10} , d_{20} , d_{60} , etc.

12.3.5. General Data Units

When activated, the option **General Data Units** displays a dialogue box such as shown in Chapter 10, Figure 10-5. In the GWW data base template, which is used in the example shown in Figure 10-5, the only space-distributed numerical parameters are coordinates and ground surface and measuring point elevations. This information is taken from the Master Data application.

12.3.6. Print Setup

The **Print Setup** option is explained in Chapter 5, Section 5.4.

12.4.

EDIT DATA MENU

12.4.1. Edit Data Submenu

Before you can create a data set or edit data you must type in the well identification number (Well Ident), and eventually its description. If this is already a well which has been entered into the GWW system from another application, the description field should be automatically filled in with information typed elsewhere. In that case the only entry necessary is the well identification. The display then looks as shown in Figure 12-1.

Only when you select **Edit Data** and open the data table with columns for grain size and percentage passing through the sieve of that size, will you be able to use other options on the edit data menu. These options are shown in Figure 12-3 and are used for editing the table (inserting or deleting rows) and saving data.

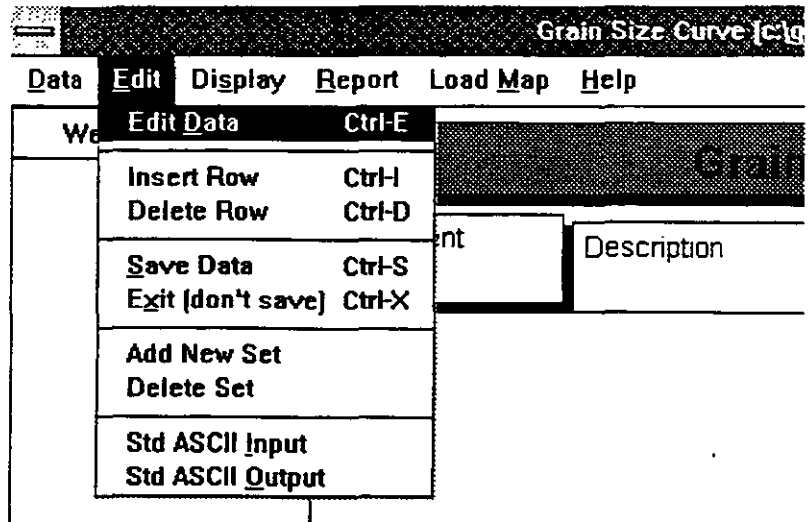

Figure 12-3

12.4.2. Number of Data Sets

When you are using this application to create a record for new grain size curve, you will be prompted first to tell the program how many sets of data you have for a particular well. The limit for each well is 5, but you may split the total number of data sets into a multiple of five assigning different well identifications, such as GSC-1/1, GSC-1/2, etc.

When you select **Edit Data** in a new well, the display will be as shown in Figure 12-4, prompting you to type the number of data sets. For the example that follows the number of data sets is three.

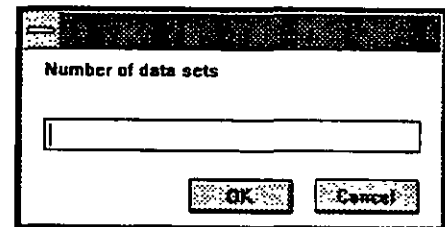

Figure 12-4

12.4.3. Data Entry
Table

After you decide on number of data sets the editor will open and display a table which will contain four columns; one for grain size diameters in millimeters, the other three for data sets. The prompt will be on the first line, waiting for you to identify this set. In the example, the three sets are representative for drilled intervals of depth: 12-15 m, 22-26 m, and 32-34 m. You may type any identification in these fields. Use TAB to move from one field to another, or Shift+TAB to return to previous fields.

In the Diam. (mm) column, type grain diameters in millimeters, starting with the smallest and gradually covering the whole grain size distribution curve. You must follow the order from the smallest to the largest size. In the remaining columns, type the cumulative percentage of the sample by weight passing through the sieve of the corresponding grain diameter.

When you finish the input, do not use TAB but hold down the CTRL key and simultaneously press S to save

GSC-1			
Diam. (mm)	12-15 m	22-26 m	32-34 m
5	5	1	12
9	9	4	16
14	14	7	21
16	16	12	25
21	21	19	29
24	24	20	31
31	31	27	44
40	40	32	54
55	55	42	64
66	66	49	75
95	95	86	99
100	100	92	100
		100	

Figure 12-5

the data. The table may look as shown in Figure 12-5.

12.5.

DISPLAY

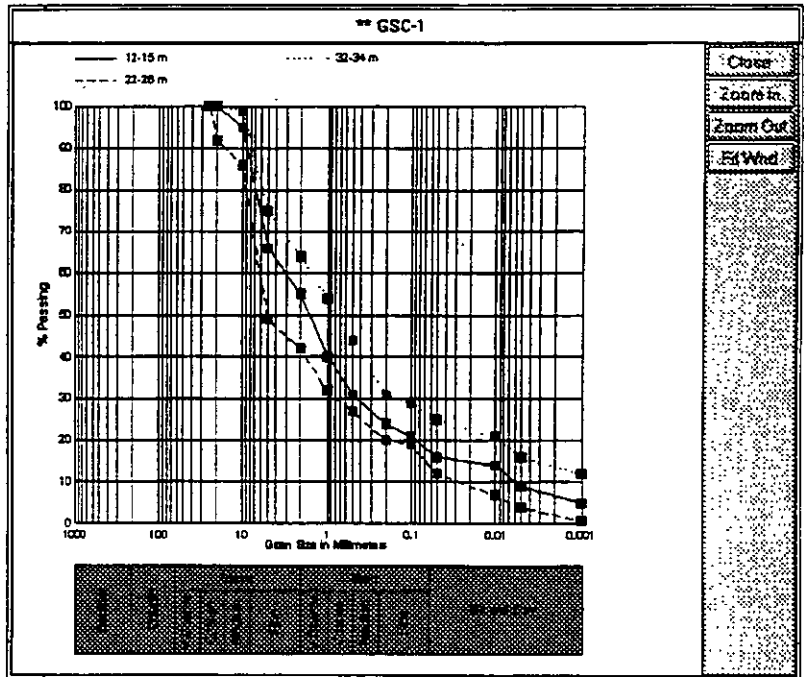

Figure 12-6

When you select the **Display** option on the menu bar, the screen may look as shown in Figure 12-6. The majority of the screen shows the grain size distribution curve. The lower portion shows one of the widely used grain size classifications identifying the limits of various fractions: silt and clay, sand, and gravel.

12.6.

REPORTING

When you select the **Report** option from the menu bar the display looks as shown in Figure 12-7. As in other applications, you

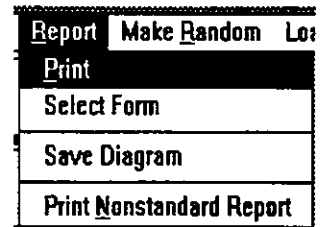

Figure 12-7

may use the standard reporting form (option **Print**) or you may select another reporting form (**Select Form**). In the latter case, a dialogue box will open suggesting the names of all available reporting forms. In addition to the curve and classification, the standard reporting form contains a header identifying the well and a table similar to the one displayed in Figure 12-5.

You may create another reporting form to which you may add a location map showing the location of the reported well or of any other well from which grain size distribution curves have been calculated.

You will use **Save Diagram** option to save the currently displayed graph for printing using the **Print Nonstandard Report** option.

12.7. LOAD MAP

This option is explained in detail in Chapter 5, subsection 5.3.2. It is used to select a working set, or individual wells to work with, directly from a map.

12.8. HELP

This is context-sensitive on-line help which guides you through various options and procedures.

12.9. ADDING OR DELETING SAMPLES

On the **Edit** menu you will notice two options: **Add New Set** and **Delete Set**. When you decide to add a new set, a new column will be opened for another set of data. The **Delete Set** option prompts you to define which sample you wish to delete. The screen may display something like what is shown in Figure 12-8.

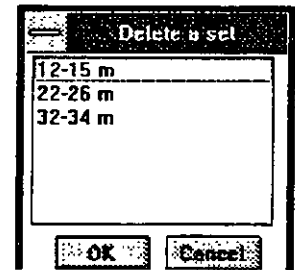

Figure 12-8

12.10. EXAMPLE

EXAMPLE EIGHT

In this example you will create one grain size distribution curve with the following information from the sieving analysis:

<u>Diameter (mm)</u>	<u>Percentage (%)</u>
0.001	3
0.005	6
0.01	10
0.05	18
0.1	22
0.5	33
1	45
2	59
5	75
10	88
20	100

The procedure is the following:

1. Select **Applications** from the main menu bar.
2. Select **Grain Size Curve**.
3. Type in the Well Ident field Test-1 and press TAB.
4. Type Landfill Monitoring Well in the description field.
5. Press PageDown twice. You will be back on the well identified as Test-1.
6. Select **Edit** on the menu bar and confirm **Edit Data**.
7. Answer with the number 1 the prompt 'Number of data sets' and click on OK.



8. In the field where is the prompt now type the depth interval for this sample, e.g. 12.5-14.5 ft. Press TAB.
9. Start typing the grain size distribution data as received from the laboratory. Type 0.001 in the column Diam. (mm) and press TAB. Type 3 under the column 14.5-16.5 ft. Press TAB.
10. Repeat input with the second pair of data: 0.005 and 6.

11. When you finish the input, after the last number, that is 100, do not press TAB but use the combination CTRL S. This saves the data. The screen should display the table as shown in Figure 12-9.

Test-1	
Diam. (mm)	14.5-16.5 ft
0.001	3
0.005	6
0.1	10
0.25	18
0.5	22
1	33
2	45
5	59
10	75
20	88
	100

Figure 12-9

12. Display the curve by selecting Display. the curve should look as shown in Figure 12-10.
13. Select **Close** to remove the curve from the display, and **Data**, followed by **Exit** to return to the main menu.

This ends example eight.



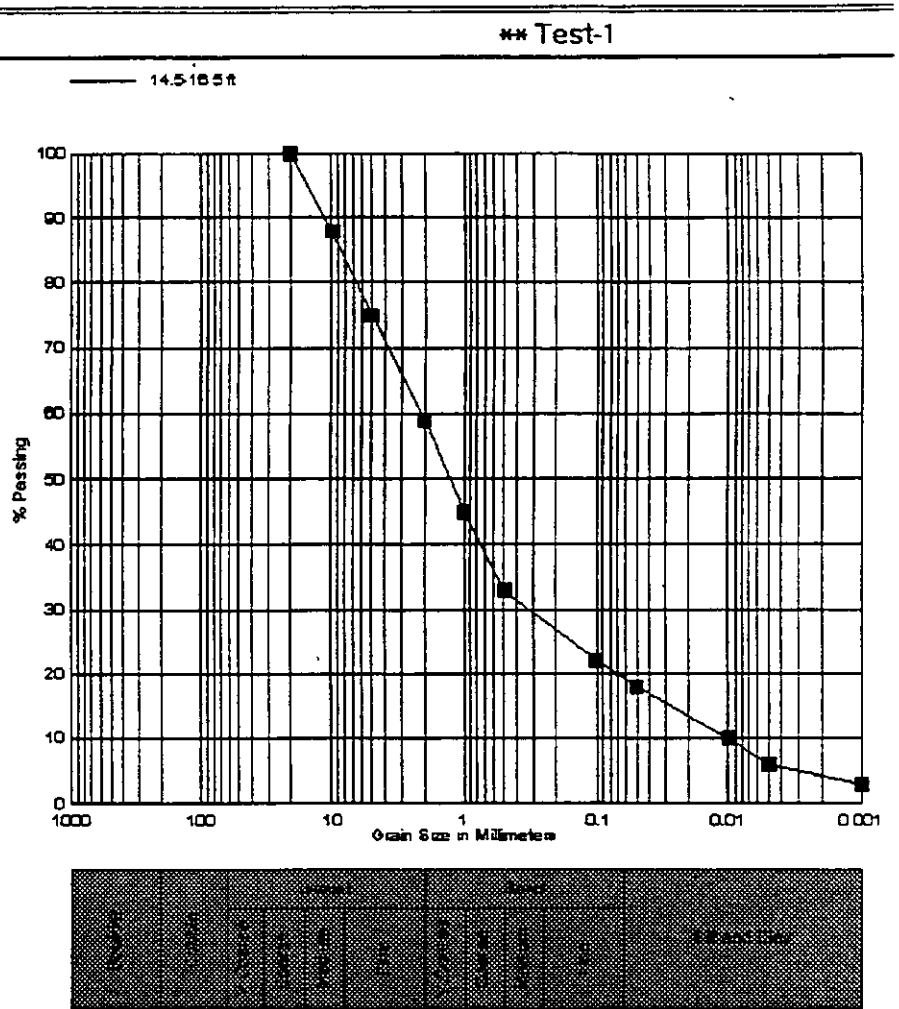

Figure 12-10



This page is intentionally left blank.

CHAPTER THIRTEEN

MISCELLANEOUS APPLICATIONS

13.1. INTRODUCTION

13.1.1. General

In this application you will find several utilities which do not create a data base and cannot be displayed or printed, but which are used to calculate well functions, hydraulic conductivities from grain size analysis, and help in designing a production well.

13.2.

APPLICATION'S CONTENT

As shown in Figure 13-1, the utilities comprising this application are the following:



Figure 13-1

- Well Functions
- Grain Size Analysis
- Well Construction Calculations

13.3. WELL FUNCTIONS

Well functions are the functions frequently used in ground water hydraulics. As shown in Figure 13-2, there are two functions:

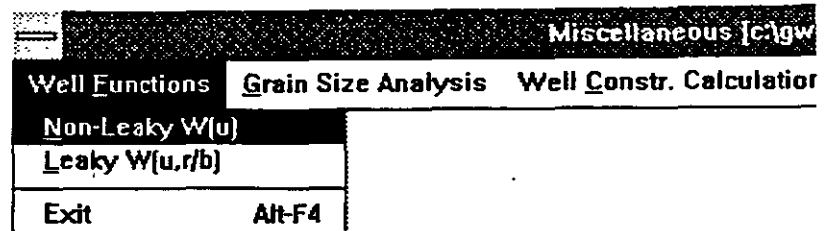

Figure 13-2

- Non-leaky, or $W(u)$
- Leaky, or $W(u,r/B)$

You will notice that you may either type the arguments of the functions to obtain the values of functions, or you may type all components that make the argument and compute the drawdown at a point in space and time as a result of pumping.

13.3.1. Non-Leaky Well Function

You select this function by moving the cursor to the Non-Leaky option, or by typing N from the Well Function menu. This is the well function for a nonleaky isotropic artesian aquifer, fully penetrated by wells and constant-discharge conditions. In other words, this is the standard well function for the most common case of ideal representation of confined aquifers. When this function is multiplied by $Q/(12.5664 \cdot T)$, where Q is the constant pumping rate and T is the transmissivity of the aquifer, the drawdown in the well is obtained.

The theory leading to the nonequilibrium equation, or Theis theory, is well documented in every ground water textbook, and will not be repeated here. The well function is tabulated as a function of the argument u , which lumps together the two most important aquifer parameters (transmissivity and storage coefficient), the distance from the pumping well at which the drawdown is calculated, and the time since the start of pumping.

Thus, the argument u is equal to

$$u = r^2 S / 4Tt$$

where, r is the distance from the pumped well to the observation point, or to point at which drawdown is being calculated; S is the storage coefficient; T is the coefficient of transmissivity; and t is time after the pumping started.

In the GWW program the dialogue box will open as shown in Figure 13-3 prompting you for input. For each of input parameters you may assign various units, whether consistent or not. You may use this dialogue box as a calculator, replacing one or more parameters and quickly obtaining the drawdowns.

Input Data	
Distance from Pumped Well	100 feet
Aquifer Transmissivity	25000 gpd/ft
Aquifer Storage Coef.	.001
Time of Pumping	30 day
Pumping Rate	300 gpm

Output Data	
u	0.00002587811
W(u)	3.984923
Drawdown	1.426006 feet

Exit

Figure 13-3

EXAMPLE NINE



As an example, calculate the drawdown at 100 feet from a well pumped at 300 gpm for 30 days. The aquifer transmissivity and storage coefficient are 25000 gpd/ft and 0.001, respectively.

1. Select Well Functions.



2. Select **Non-Leaky** $W(u)$.
3. Type 100 for distance, change to feet if another unit is displayed (click on down arrow box, select feet, click on **OK**). Press **TAB**.
4. Type 25000 for transmissivity, change units to **gpd/ft**. Press **TAB**.
5. Type 0.001, and press **TAB**.
6. Type 30, press **TAB**, confirm days as units of time, press **TAB**. Notice that at this moment the values of function's argument u and the function itself are displayed in the **Output Data** fields.
7. Type 300 for pumping rate, press **TAB**, check that units are in **gpd**, and press **TAB**. The screen should look as shown in Figure 13-3. The result is the following:
 - Function's argument = 0.00002587811
 - Well Function = 9.984923
 - Drawdown = 1.426 feet

13.3.2. Leaky Well Function

This routine calculates the well function for a leaky artesian aquifer with fully penetrating wells without water released from storage in the aquitard and under constant-discharge conditions. Although the values of $W(u,r/B)$, in terms of the practical range of u and r/B , are given by Hantush and many other authors in tabular form, this portion of the program calculates not only the function $W(u,r/B)$, but also the arguments u and r/B from basic hydrogeological and pumping parameters.

These parameters are:

r, T, S, t, Q, m, P

where:

r = distance from pumped well

T = transmissivity of main aquifer



S = storage coefficient of main aquifer

t = duration of pumping

m = thickness of semiconfining layer

P = vertical permeability of semiconfining layer.

The parameter B , which is important in the Hantush leaky aquifer theory, is defined as follows:

$$B^2 = T/P/m$$

The ratio r/B , which is one of arguments of the leaky well function, is dimensionless.

EXAMPLE TEN



As an example, the following parameters are input:

$r = 10$ feet

$T = 25000$ gpd/ft

$S = 0.001$

$t = 30$ days

$Q = 300$ gpm

$m = 10$ feet

$P = 1000$ gpd/ft²

The program-calculated values are the following (see Figure 13-4):

Well Function		9:24 AM
Input Data		
Distance from Pumped Well	10	feet
Aquifer Transmissivity	25000	gpd/ft
Aquifer Storage Coef.	.001	
Time of Pumping	30	day
Pumping Rate	300	gpm
Thickness of Semiconfining layer	10	feet
Hydraulic Conductivity of Layer	1000	gpd/day/ft ²
Output Data		
u	0.00000258781	
B	15.52252	feet
W(u, r/B)	1.445307	
Drawdown	2.061015	feet
Exit		

Figure 13-4

$$u = 0.000000258781$$

$$B = 15.52252 \text{ feet}$$

$$W(u,r/B) = 1.445307$$

$$\text{Drawdown} = 2.061 \text{ feet}$$



13.4. GRAIN SIZE ANALYSIS

This is a utility program for calculating permeability values (hydraulic conductivities) from grain-size analysis (grain-size distribution curves). The permeabilities can

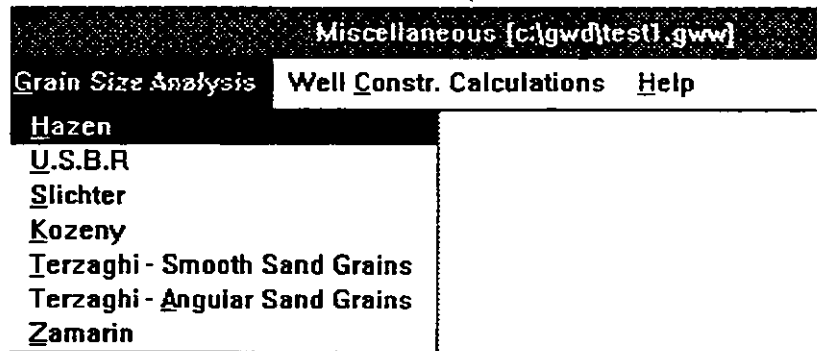

Figure 13-5

be calculated using one of seven available empirical formulas as shown in Figure 13-5. Each calculation requires some or all of the following input parameters:

1. Effective grain diameter (d_{10} or d_{20}), or the total grain-size distribution.
2. Temperature of water in aquifer formation (due to viscosity dependance on temperature).
3. Empirical coefficient which distinguishes between smooth and clean sand on one side and angular and clayey sand on the other side.

4. Total porosity of sand.

The corrections for water temperature are probably not important; the empirical formulas produce only a correct order of magnitude considering the way in which formation samples are usually collected.

The Hazen formula applies to sands and gravels with effective grain diameter between 0.1 and 3.0 mm and uniformity coefficient d_{60}/d_{10} less than 5. To select the empirical coefficient which considers grain uniformity, sorting, and cleanness, please note that typical values are as follows:

0.4 - 0.8 for clayey and nonuniform sand

0.8 - 1.2 for clean and uniform sand. The more uniform the sand, the higher the coefficient.

One example is shown in Figure 13-6.

The screenshot shows a software window titled "Hazen's Formula" with a clock in the top right corner displaying "9:25 AM". The window is divided into two main sections: "Input Data" and "Output K".

Input Data:

- D10 [mm]: .5
- Empiric Coeff.: .8
- Water Temperature [°C]: 20

Output K:

- Value: 0.3716000
- Unit: cm/s

At the bottom of the window is an "Exit" button.

Figure 13-6

The U.S. Bureau of Reclamation formula (due to Creager, Justin, and Hinds) requires the d_{20} as the effective grain diameter (in mm), without any corrections (for temperature, or an empirical coefficient).

The Slichter formula applies to sands and gravels with effective grain diameter between 0.1 and 3.0 mm and

uniformity coefficient d_{60}/d_{10} less than 5. The formula requires the knowledge of total sand porosity, and there is also a correction for formation water temperature. With the Slichter formula, the porosity (total) must be typed as a fraction of 1.0, temperature in $^{\circ}\text{C}$, and d_{10} in mm (screen diameter of 10% of the total sample retained on the screen).

The Kozeny formula requires the following input: total porosity as a fraction of one, effective diameter (d_{10}) in mm, and the formation water temperature.

The Terzaghi formula, which applies mostly to coarse-grained sand and gravel, needs the input values of d_{10} , porosity as a fraction of one, and temperature. There is also a correction coefficient which takes into account two categories of sand grains: smooth and angular.

There are several error trapping routines which warn you if a parameter is beyond the acceptable range. One such message is displayed in Figure 13-7 for the Terzaghi (smooth) formula.

Terzaghi's Formula (Smooth)

Input Data

D10 [mm]

Total Porosity

Water Temperature [°C]

Output K

cm/s

ERROR! 9:27 AM

Porosity must be between 0.013 and 1 !

Figure 13-7

The Zamarin formula requires the input of the whole grain-size curve. Each fraction of sample analysis (typed as 0.12 if 12% of the whole sample falls within the interval) is multiplied by a corresponding weighting factor,

which assigns a greater importance to finer than to coarser fractions. The temperature correction is also introduced in the same manner as in the Slichter formula. The dialogue box for the Zamarin formula is shown in Figure 13-8.

Figure 13-8

Zamarin's Formula

Input Data

Fraction of Sample

<0.01	0.50 - 1.00
0.01 - 0.05	1.00 - 2.00
0.05 - 0.10	2.00 - 3.00
0.10 - 0.15	3.00 - 5.00
0.15 - 0.25	5.00 - 7.00
0.25 - 0.50	7.00 - 10.00

Porosity

Water Temperature, [°C]

Output K

cm/s

13.5. WELL CONSTRUCTION

This portion of the program may help you select proper casing diameter and proper screen length and to evaluate whether the screen entrance velocity is above a critical velocity. The routine is written in such a way that you must assign all but one parameter, and the program will calculate the missing parameter.

The entries in this routine are:

- Screen diameter
- % of open screen area
- Pumping rate

- Maximum entrance velocity
- Length of screen

The dialogue box for this routine is as shown in Figure 13-9. You will notice the hint: *Type ? in field to be computed*. After you enter all other values, the program will replace

Well Construction Parameters		9:31 AM
Screen Diameter	<input type="text"/>	inch
% of Open Area of Screen	<input type="text"/>	
Pumping Rate	<input type="text"/>	gpm
Max. Entrance Velocity	<input type="text"/>	ft/s
Length of Screen	<input type="text"/>	inch
HINT: Type ? in field to be computed		
Exit		

Figure 13-9

the question mark with the calculated value. You will also notice that for each parameter except the percentage of open screen area, which is dimensionless, you may select units of your choice.

Recommended Casing Diameter. The program relates the design pumping rate of the well pumped with a vertical turbine pump to the optimum casing diameter. The diameter of the production-well casing should be two nominal sizes larger than the bowl of the pump to prevent the pump shaft from bending, to reduce head losses and to allow measurements of water levels in the well. The casing diameter may be reduced below the maximum anticipated pump setting depth. Suggested casing diameters for various pumping rates are calculated according to recommendations in Walton (*Groundwater Resource Evaluation*, McGraw-Hill, 1972, p.299).



Screen Length. The recommended screen length is a function of entrance velocities into the well. The screen length as calculated in this program is based in part on the effective open area of a screen and an optimum (critical) screen entrance velocity. If the length of a screen is less than recommended, implying higher entrance velocities than the maximum permitted, there will be a possibility of screen openings being clogged by the migration of finer particles from the aquifer toward the screen. This process and the critical screen entrance velocity depend largely on the type of aquifer material, which is reflected in aquifer permeability. Thus, the input to the program consists of two components: (a) open screen area, (b) selected critical (maximum) entrance velocity.



EXAMPLE ELEVEN

Figure 13-10 displays an example in which the screen diameter is calculated when the screen length and the per-

Well Construction Parameters			9:32 AM
Screen Diameter	?	inch	↓
% of Open Area of Screen	17		
Pumping Rate	300	gpm	↓
Max. Entrance Velocity	.1	ft/s	↓
Length of Screen	20	feet	↓
HINT: Type ? in field to be computed			
Exit			

Figure 13-10

centage of screen open area are known, maximum entrance velocity is assigned, and the well is to be pumped at a certain design rate.



The example is as follows:

A screen 20-ft long, with 17% open area, is to be used for pumping from a well at 300 gpm pumping rate. What is the minimum permissible screen diameter which will guarantee that the critical entrance velocity of 0.1 ft/sec will not be surpassed?

You should start by placing a question mark in the first field (screen diameter). Type 17 for the percentage of open screen area, 300 gpm for the pumping rate, 0.1 ft/s for the maximum entrance velocity, and 20 feet for length of the screen.

The program returns the value of 2.8 inches for screen diameter.

Continuing with this example we will use metric units for a similar case: the open screen area is 17%, the screen length 10 m, the well is to be pumped at 1000 m³/day and the maximum permitted entrance velocity is 3 cm/s. Find the well screen diameter which will keep the entrance velocity less than the maximum permitted. Find also the recommended casing diameter considering that a vertical turbine pump with rated capacity of 1000 m³/day is designed to be installed in such a well.

Place a question mark in the field *Screen Diameter*. Type 17 for the % of *Open Area of Screen*. Type 1000 for the *Pumping Rate*, and change the unit to m³/day. Type for *Max. Entrance Velocity* 3 and change the unit to cm/s. Type 10 for the *Length of Screen* and change the unit to meters. As shown in Figure 13-11, the program returns 2.8 inches for the minimum recommended screen diameter, and 6 inches for the casing diameter in which a vertical turbine pump will be housed.

This ends example number eleven.



Well Construction Parameters			9:35 AM
Screen Diameter	2.825817	inch	↓
% of Open Area of Screen	7.00		
Pumping Rate	1000.0000	m3/day	↓
Max. Entrance Velocity	3.000000	cm/s	↓
Length of Screen	10.000000	m	↓
HINT: Type ? in field to be computed			
Exit			
Recomended Diameter	6.000000	inch	↓

Figure 13-11

This page is intentionally left blank.

14.1

INTRODUCTION**14.1.1. General**

Using this application you may create lithologic, hydrogeologic or stratigraphic cross sections, and display on the screen and in reporting forms the following:

- Lithology at borehole sites.
- Ground surface elevation along the cross section line.
- Water level lines (static, dynamic, drawdown) along the cross section line.
- Stratigraphic and lithologic contacts.
- Well construction details, including the position of screen.
- One or two chemical constituents or contaminants along well's depth.

This application is a utility for drawing cross sections, adding a legend, and reporting. It uses the information from the data base that was created using the Well Log and Lithology application (see Chapter Eight). The "intersection" lines, or various elevation lines added onto the cross section, are created using the Mapping application. The chemical concentration data are taken from the application Concentration-Depth.

14.1.2. Application's Content

As shown in Figure 14-1, the Cross Section application is comprised of the following major options:

- Cross Sections.
- Wells.



Figure 14-1

- Map.
- Grid Model.
- Options.
- Help.

14.2.

CROSS SECTION

The **Cross Section** menu serves to create a cross section, to assign various attributes to the display and report, to save or copy cross sections, to select vertical and horizontal scales and to check dimension of the drawing. It is also used to make a legend box with various text, including scale, and to position the legend onto the drawing.

This menu is also used to select a reporting form and to print a cross section.

Cross sections are created and saved as internal files. After you create a section, display it on the screen, and eventually print it, you may save the **completed** section under its own name. Cross sections then become an integral part of the *Ground Water Information System* (GWIS). You may retrieve cross sections any time you open your data base, you may print cross sections or add some content.

Depending on when you activate the **Cross Section** menu, some or all of the following options will be available, as shown in Figure 14-2:

- New Cross Section
- New Cross Section Like
- Old Cross Section
- Clear Cross Section
- Save Cross Section
- Save Cross Section As ...
- Edit Parameters
- Units
- Make Legend
- Write Text to Legend
- Write Scale to Legend
- Print Cross Section
- Print Setup
- Dimension
- Exit.

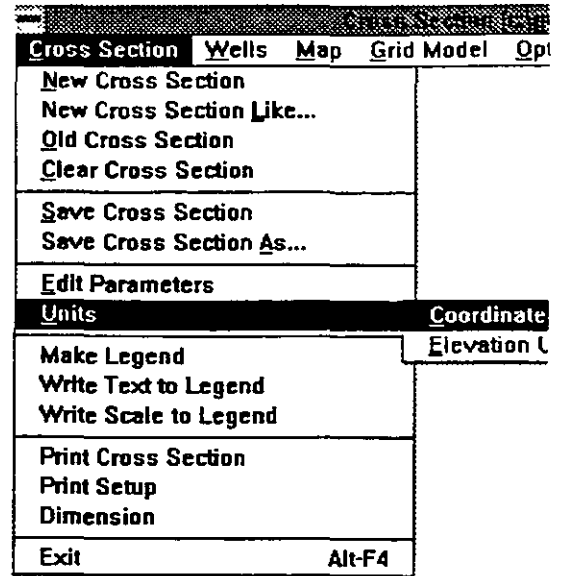

Figure 14-2

14.2.1. New Cross Section

When you select **New Cross Section**, the dialogue box as shown in Figure 14-3 will be displayed. It will prompt you to type in the X and Y coordinates for the starting and ending points, the interval of depth (Z coordinate) to be covered by the cross section, to assign a label step for the vertical axis, and to select a horizontal and vertical scale.

Figure 14-3

You will also have a chance to control the drawing by selecting the **More** button (see Figure 14-3) which will then open another dialogue box as shown in Figure 14-4. There, you may control the drawing margins, colors of various parts of the drawing, lines and fonts. Keep in mind that the margins refer to the **f r a m e** around the drawing, not to page margins. This is not a "fit-to-page" drawing, but rather it should fit the reporting form that you may have created using the option

Figure 14-4

Tools from the main menu bar, followed by Report File Editor.

The **New Cross Section** option is also used when you select a cross section line from one of the existing maps by selecting the starting and ending points with a mouse. You will learn how to do this in Section 14.5, Adding Wells by Drawing Cross Section Line on the Map.

14.2.2. New Cross Section Like ...

Use the **New Cross Section Like ...** option to create a new cross section without lithology, without wells, or without any other content except for the coordinates of the starting and ending points, scales, and drawing parameters. Actually you will use everything from the existing section except the content. This option is useful when you are not satisfied with the content for whatever reason. For example, you may wish to modify the legend, change the attributes for any line that is displayed, or reduce or expand the width of lithological columns at boreholes.

14.2.3. Old Cross Section

When you select this option the dialogue box such as the one shown in Figure 14-5 will open. The GWW program displays the list with all named cross sections saved in previous sessions.

You will use this option when you want to display the cross section, print it as it is, or modify it before printing and/or saving. When you select one of listed cross sec-

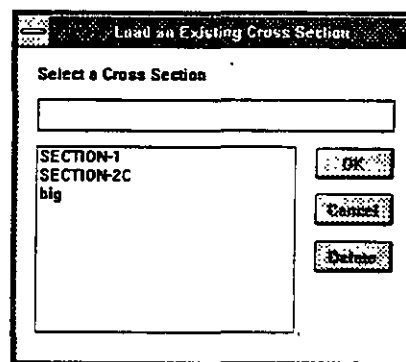

Figure 14-5

tions, it will be displayed on the screen. The name of the cross section will be displayed in the title bar on the top.



NOTE. Always look at the title bar to see with what you are currently working. This helps to prevent accidental changes, unwanted saving and overwriting.

**14.2.4. Clear Cross
Section**

This option clears the content of the currently selected cross section. What remains is the coordinate "system", that is the X and Y coordinates of the starting and ending points, scales, and attributes. If you keep working with this "cleared" cross section and save it under the same name, that is by selecting option **Save Cross Section**, the previous content will be erased ("cleared") and the new content will be saved instead.

**14.2.5. Save Cross
Section**

When you finish working on a cross section you may want to save it. You have two options: (1) to save it under the name that is displayed in the title bar, (2) to save it under a different name. The option **Save Cross Section** saves only under the same name as shown in the title bar. If this is an untitled cross section, that is a new section, this option will be dimmed, which means unavailable.

**14.2.6. Save Cross
Section As ...**

When you work on a new cross section, this will be the only "saving" option available. You will be prompted to assign an internal cross section name. If you worked with an existing cross section (you used the option **Old Cross Section**), you will have the option to save it by selecting either **Save Cross Section**, in which case the same section title will be kept and its content overwritten, or by using the option **Save Cross Section As ...**, in which case you will assign another name to the modified section without affecting the content of the one with

which you started. In this second case the dialogue box as the one shown in Figure 14-6 will be displayed.

14.2.7. Edit Parameters

You may edit the parameters of an existing cross section. When you select this option, the dialogue box as shown in Figure 14-7 will be displayed. You may modify anything in this box, although normally, you will

probably want to change one or both scales, and the vertical interval of the display (Z Coordinate From .. To).

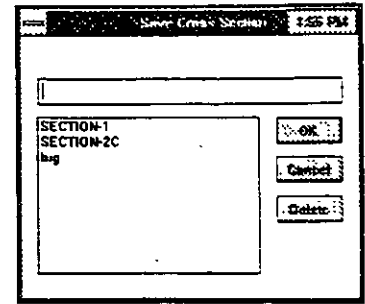

Figure 14-6

Starting Point [m]			
X	<input type="text" value="653600"/>	Y	<input type="text" value="937150"/>
Ending Point [m]			
X	<input type="text" value="674300"/>	Y	<input type="text" value="966625"/>
Z Coordinate [m]		Label Step	
From	<input type="text" value="-100"/>	To	<input type="text" value="120"/>
		<input type="text" value="10"/>	
Scales			
Horizontal 1:		Vertical 1:	
<input type="text" value="175000"/>		<input type="text" value="1800"/>	
<input type="button" value="OK"/>		<input type="button" value="Cancel"/>	
		<input type="button" value="More >>"/>	

Figure 14-7

Remember that there is the More option which opens another dialogue box in which you control drawing parameters. The normal procedure in editing cross section parameters would be to select scales and then check the dimension (size) of the cross section by selecting option **Dimension** from the same menu. The display may look as shown in Figure 14-8. If not satisfied, you may return to the **Edit Parameters** option and modify one or both scales.

- 14.2.8. Make Legend** The legend will usually consist of some text, scales, lithological symbols and descriptions, and various in-

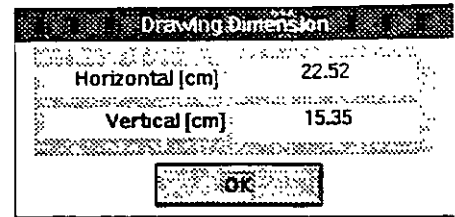

Figure 14-8

tersection lines that you may superimpose onto the drawing. Using this option, you may position the legend box onto the drawing, assign its X and Y size, and add some offset to the frame to move it from the drawing's frame. To learn more about creating a legend, please read Section 14.8.

- 14.2.9. Write Text to Legend** You may write some text to the legend, line by line. Each time you select this option, you will be prompted for text and for fonts for the text. The text lines will be printed in vertical succession from top to bottom within the legend frame you designed using the option **Make Legend**.
- 14.2.10. Write Scale to Legend** Using this option, the program will add horizontal and vertical scales to the legend.
- 14.2.11. Print Cross Section** When you decide to print a cross section, the program will display the list of all the available reporting forms. You may select one of the forms, and the program will print the report.
- 14.2.12. Print Setup** This option is explained in Chapter 5, Section 5.4.
- 14.2.13. Dimension** As mentioned earlier in paragraph 14.2.7., you will use this option frequently to check the size of the drawing.

The numbers, which are in centimeters by default, as shown in Figure 14-8, include drawing margins. The following is important to keep in mind: cross sections are printed using either a default reporting form or one which you created. When you create a reporting form, you assign the dimension and position of the drawing field. The dimensions assigned using the **Tools** option on the main menu and **Report Form Editor** should match the dimensions of your current cross section in order to print its whole content.

For example, currently you have a cross section reporting form which is prepared for the drawing size 250 mm horizontally by 154 mm vertically in landscape orientation, and 180 mm horizontally by 250 mm vertically in portrait orientation. If your drawing's dimensions, as displayed using this option, are less than the reporting form's drawing field, the cross section will be centered within the drawing field. If they are greater than the drawing field, a portion of the cross section will not be printed. What will be printed will start at the lower left corner of the reporting form's drawing field.

14.3.

ADDING WELLS TO A CROSS SECTION

The cross section would not be the subject of this chapter had it not been for wells that have lithology identified and described. Adding wells to a cross section is the next step after you have selected your cross section line and defined its parameters.

The second option on the application's menu bar, **Wells**, is comprised of the following, as shown in Figure 14-9:

- Select Working Set
- Select Working Group

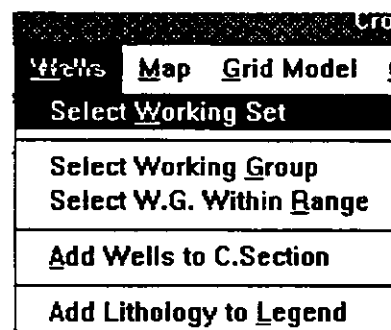

Figure 14-9

- Select Working Group Within Range
- Add Wells to Cross Section
- Add Lithology to Legend.

14.3.1. Select Working Set

You use the **Select Working Set** option in the same manner as in any other application. Its use is explained in Chapter 5, section 5.3. Its purpose is to reduce a large set with many wells to a smaller set of wells which may be selected for any reason.

14.3.2. Select Working Group

Only the wells that are included in a working group can be added to a cross section. You may select a working group in many ways. One would be to use this option on the **Wells** menu, and manually pick wells one by one from the Unselected list of wells. The other would be to use this option and apply one of selection conditions. For example, you could use well names, X or Y coordinates, type of aquifer, etc.

An alternative to selecting wells by names or identification is to select them directly from a map. This will be explained in Section 14.4. Whichever method of selection you choose, the list of selected wells will look something like what is shown in Figure 14-10.

14.3.3. Select Working Group Within Range

Once you identify a cross section line and have a list of wells comprising your working set, you may create wells to make your working group and add them to a cross section by specifying the range from the section line. When you select this option, the number you supply is interpreted by the program as the spacing on either side of the cross section line within which the wells will be used and projected onto the section line. If you type 400, for example, this would mean that you want all wells

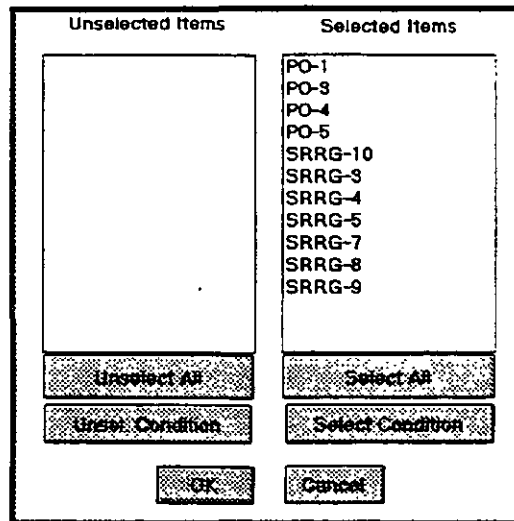

Figure 14-10

that are less than 400 m from the cross section line to be projected onto the line.

Before you decide to create a working group, it is important to check that there are no wells currently making the group. The method that you use to select wells will supersede new wells onto the list of existing wells in the group, and you may plot some unwanted wells. Always display the list of selected wells by returning to the option **Select Working Group**. Check the list, as shown in Figure 14-10, before you apply the next option, **Add Wells to Cross Section**.

14.3.4. Add Wells to Cross Section

When you are satisfied that wells on the list as displayed with the option **Select Working Group** are the ones you wish to have plotted, you may apply the option **Add Wells to Cross Section**. There may be one intermediate step before you do this; that is select the width of lithological columns for wells. This is done by using option **Options** from the menu bar, which will be explained in Section 14.6.

After you select **Add Wells to Cross Section**, the wells selected will be plotted.

14.3.5. Add Lithology to Legend

Using this option you will be prompted to select lithological symbols that may appear on the currently displayed cross section to have them become a part of the legend.

14.4. MAP

Selecting cross section lines and wells that will be plotted on cross sections directly from a map is a much more convenient method than creating cross sections by typing coordinates of starting and ending points and picking up wells manually. This option on the menu bar, which is highlighted in Figure 14-11, prompts you first to load a map, and then to create either a working set or a working group. Of course, to use the option, you must have created one or more maps showing the locations of wells with available lithological data. You may create such a map using the Mapping application.

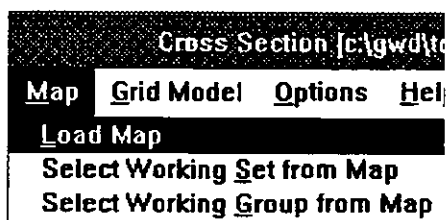

The procedure for selecting cross section lines and wells using maps is explained with the following example:

Figure 14-11

1. Select Load Map.
2. The Load Map dialogue box as shown in Figure 14-12 is displayed. In this example only one map has been created using the Mapping application. The map was saved under the name BASIC. You will double click on the name BASIC, or click it once and press ENTER.
3. The map as shown in Figure 14-13 will

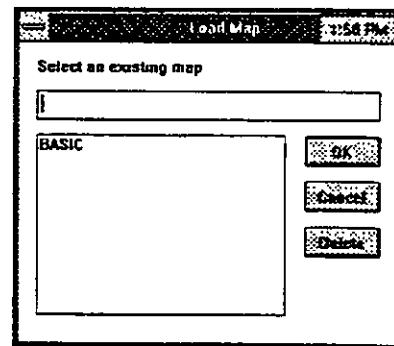

Figure 14-12

be displayed. This map contains (a) locations and identifications of wells, (b) water level contours for a certain date. Only locations and identifications of wells are of importance for lithological cross sections.

4. You will notice several buttons vertically aligned on the right side. These buttons offer several options for

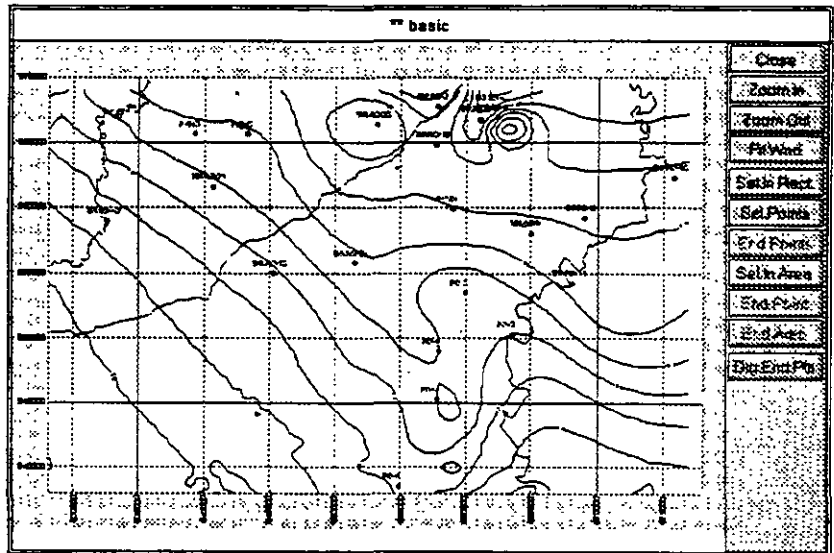

Figure 14-13

selecting wells. You may select wells by selecting a rectangle, a free drawn area, points by points, or by drawing a cross section line and selecting a range from the line.

Figure 14-14 shows a portion of the button line. If you select the button **Sel.In Area**, you will need to draw a polygon around the wells that you wish to select. You will start by clicking the mouse on one point, move the mouse a certain distance, click it again, and repeat this until you come close to the initial point. Then you will click on the **End**

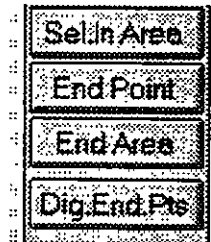

Figure 14-14

Point button to close the area. Using this button, the last selected point will connect with the first point, completely closing the area. You may repeat the same procedure with another area, selecting some distant points that could not be entered into the first area. When you have finished creating areas for selecting wells to be in the working group (or working set), you must click on **End Area**. The selected wells will then become a part of either a working group or a working set, depending on what you have attempted to create.

Another way to select wells is to use the buttons **Sel.Points** and **End Points** as shown in Figure 14-15. Keep in mind that every method selected adds new wells to the working group list. So if you wish to start from scratch, you should go to **Select Working Group** option and unselect all wells before you start adding them to the list.



Figure 14-15

When you click on the **Sel.Points** button you may proceed by clicking on or near a well location to be selected, one by one. Each time you click on a new well its identification is added to the working group list. To end the selection, click on **End Points**.

You may also use the option **Sel.In Rect.** which stands for selecting wells within a rectangle. Click on this button, move the cursor to one of rectangle corners, click and drag the mouse and notice that a rectangle is being shaped. The button **Sel.In Rect.** and the rectangle selected with four wells in it are shown in Figure 14-16.

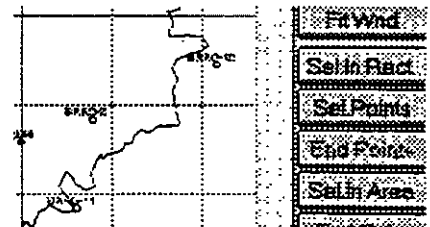

Figure 14-16

14.5.

**ADDING WELLS BY
DRAWING CROSS
SECTION LINE ON
THE MAP**

You may also add wells by drawing a cross section line on the map. To do this, select wells by defining the cross section line, and by displaying all wells that are 5000 m from the line. Select the last button labeled as **Dig.End.Pts**, as shown in Figure 14-14 and blown up in Figure 14-17. Move the cursor to one end of the future cross section line. Hold the left button of the mouse and drag the cursor to other end of the line. Release the button. The line will be drawn as shown in Figure 14-18.



Figure 14-17

Now go to the **Cross Section** menu and select **New Cross Section**, as shown in Figure 14-19. The program will display the dialogue box named **Cross Section Parameters** as shown in Figure 14-20. Only the coordinates of starting and ending points of the cross section line, as drawn by you in the step before, will be displayed. You should fill in other fields to complete the cross section definition. The display may look as shown in Figure 14-21. You

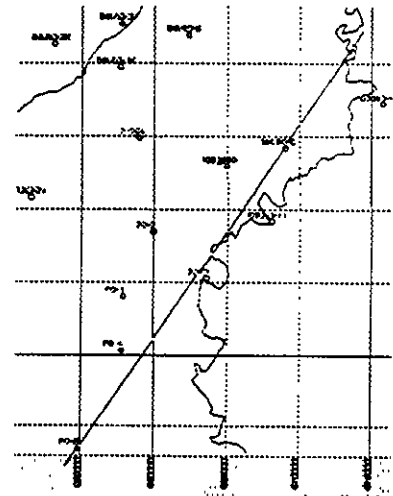

Figure 14-18

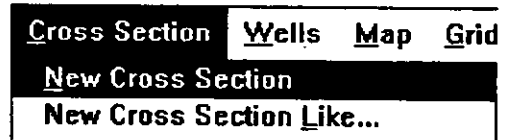

Figure 14-19

Cross Section Parameters

Starting Point
X Y

Ending Point
X Y

Z Coordinate
From To Label Step

Scales
Horizontal 1: Vertical 1:

OK Cancel More >>

Figure 14-20

should definitely check the dimension to decide whether you need to modify the scale.

If your working group was empty, you should go to the Wells menu, and select the option **Select W.G. Within**

Cross Section Parameters 2:05 PM

Starting Point
X Y

Ending Point
X Y

Z Coordinate
From To Label Step

Scales
Horizontal 1: Vertical 1:

OK Cancel More >>

Figure 14-21

Range. When prompted for distance, type 5000 as shown in Figure 14-22.

Now select the option **Select Working Group** to confirm that only the wells

Select Working Group Within Range

Enter distance

OK Cancel

Figure 14-22

you wish to have plotted comprise the list. The display in our example looks as shown in Figure 14-23.

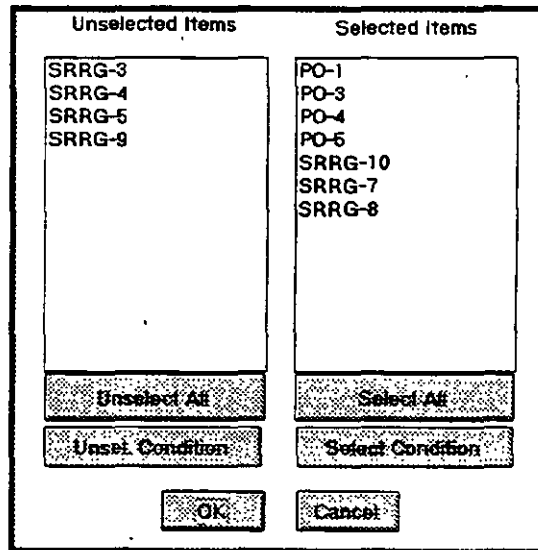

14.6.

Figure 14-23

CREATING CROSS SECTION WITH SELECTED WELLS

The final step is now to add the selected wells to create the cross section. From the **Wells** menu select **Add Wells to C.Section**, as shown in Figure 14-24. In a moment, the wells will be plotted, and the screen display may look as shown in Figure 14-25. However, the widths of well lithological columns will be 10 mm by default. If this is not what you would like to have, before you decided to plot wells you should have selected an-

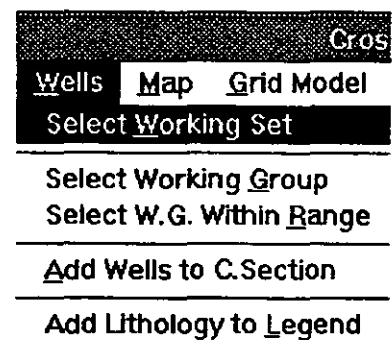

Figure 14-24

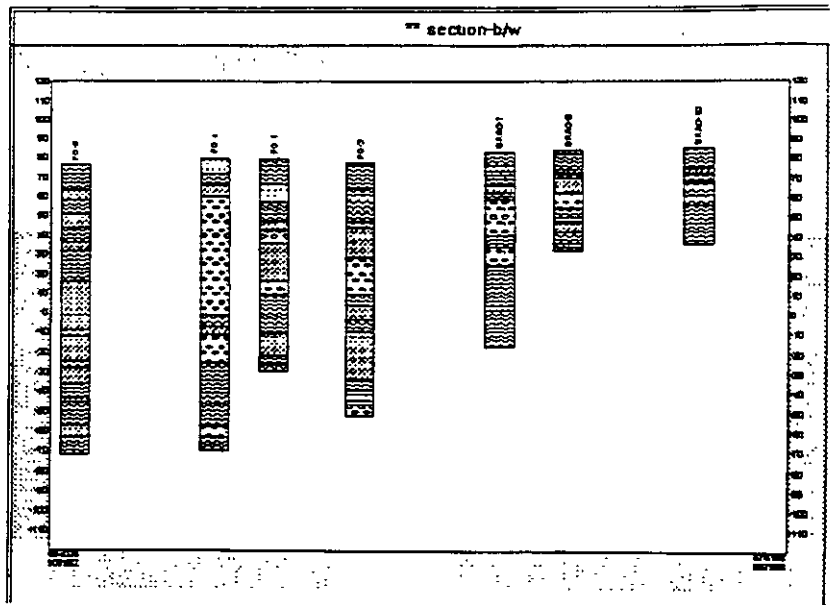

Figure 14-25

other width. This is done by selecting the option **Options** on the menu bar, as shown in Figure 14-26, then selecting **Column Plotting Style** and clicking on **Set Column Width**. The dialogue box labeled **Log Plotting Style** will open prompting you to type another column width in millimeters. The dialogue box is displayed in Figure 14-27. Type the new number and select **OK** or press **ENTER**.

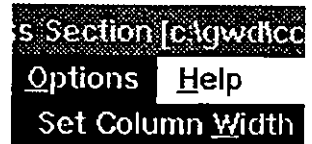

Figure 14-26

14.7.
**ADDING
 INTERSECTION
 LINES**

In the terminology of the GWW package,

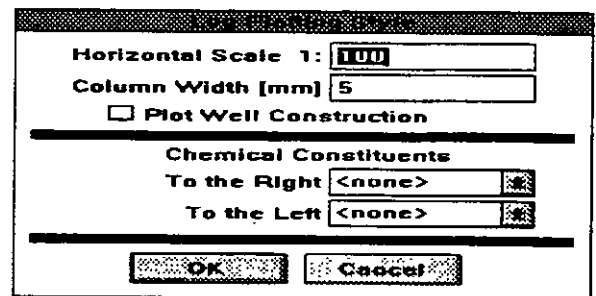

Figure 14-27

"intersection line" is the vertical projection of a grid model along the cross section line. You will learn in Chapter 15, Mapping Application, what grid models are and how they are created. A grid model is a collection of some value for each cell of a model. In the Mapping Application you decide on the grid, the number of rows and columns, and the spacing along rows and columns. You then use the program to interpolate or extrapolate random values at some points to create a grid model in which a selected parameter will have one value for each cell of the model. These grid models are saved internally with some meaningful names.

In the case of cross sections, you may be interested in having the following lines drawn:

- Ground surface elevation.
- One or more water table or piezometric pressure elevations.
- One or more lines connecting either lithologic units or stratigraphic formations.

We may add one or more such lines to complement our lithologic cross section.

14.7.1. Grid Model Menu

You will notice the option **Grid Model** on the application's menu bar. When you select this option the submenu as shown in Figure 14-28 will be displayed. The **Get Intersection Line** option offers a list of all possible grid models in your current GWIS. The **Edit Line Attributes** is a routine Windows procedure to select colors, line thickness and pattern (solid, dashed, dotted, etc.), and labeling fonts. The **Plot Intersection Line** is the plotting option or adding the line onto the cross section. The

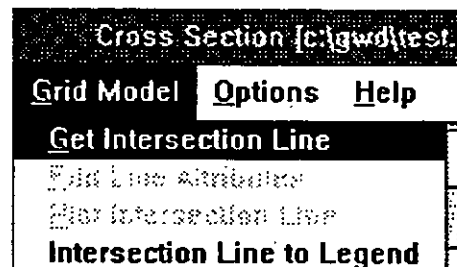

Figure 14-28

Intersection Line to Legend is used to add the line with its attributes and some text defining the line to the legend. You should use these options starting with the top and ending with the bottom.

14.7.2. Get Intersection Line

When you select the option **Get Intersection Line**, the dialogue box as shown in Figure 14-29 displays a list of all available grid models and prompts you to select one.

14.7.3. Edit Line Attributes

When one of the available grid models is selected, the options **Edit Line Attributes** and **Plot Intersection Line** are available, as shown in Figure 14-30. When you click on **Edit Line Attributes**, the dialogue box as displayed in Figure 14-31 prompts you to modify the default line pattern (one of six possible combinations, see Figure 14-32); default line thickness, which is 2 (2/10

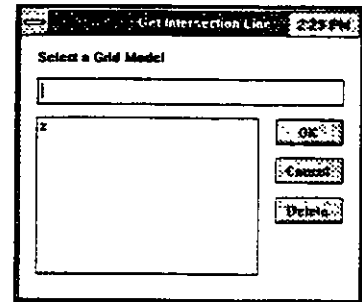

Figure 14-29

of a millimeter) using the thicknesses from 2 through 10 (see Figure 14-33); line color using the whole Windows-supplied palette; label font (see Figure 14-34); etc. You may break the line by inserting certain text such as SWL for static water level, or the name of a formation. For this you use the Label field. The entries Distance #1 [mm], which by default is 40 mm, means that your label will start 40 mm from the beginning of the cross section line. The second distance num-

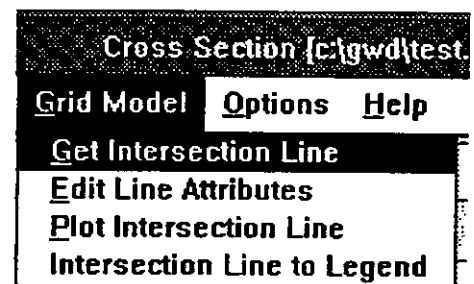

Figure 14-30

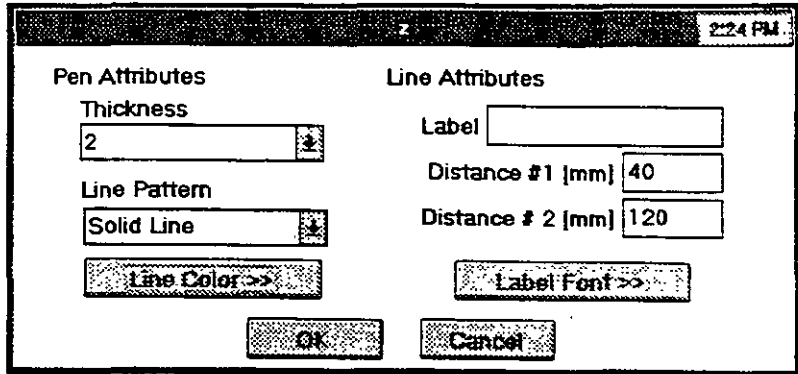

Figure 14-31

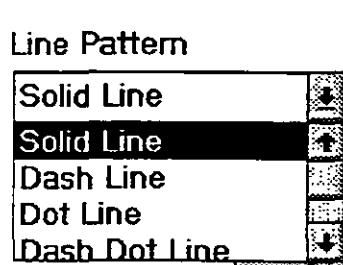

Figure 14-32

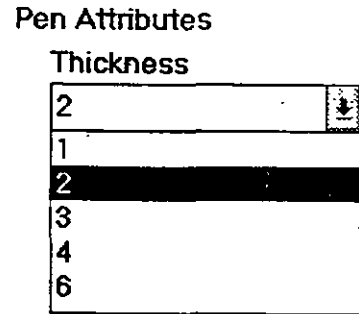

Figure 14-33

ber, by default 120 mm, means that there will be a gap of 120 mm between two successive labels. For example, if you are plotting the ground surface elevation line and want to label it as LS Elevation, the plotted segment with the label may look as shown in Figure 14-35.

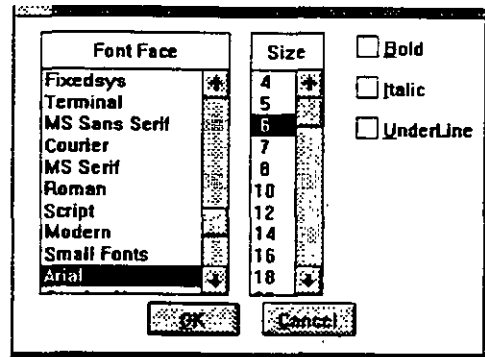

Figure 14-34

14.7.4. Plot Intersection Line

Once you have selected a line to plot, edited it and modified the defaults, you may plot it by selecting the option **Plot Intersection Line**.

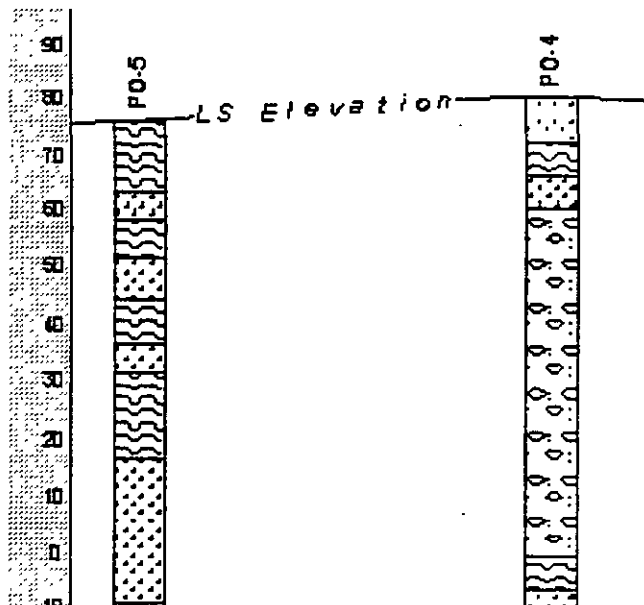

Figure 14-35

14.8. LEGEND

Adding a legend to a cross section was briefly mentioned in Sections 14.2.8. through 14.2.10. You will notice a block of options on the **Cross Section** menu, Figure 14-36, on the **Wells** menu, Figure 14-24, and on the **Grid Model** menu, Figure 14-28.

The option **Make Legend** on the **Cross Section** menu prompts you to select the relative position of the legend frame within the drawing. The dialogue box is displayed in Figure 14-37. With a little bit of patience you may place the legend frame to any place on the cross section draw-

- Make Legend
- Write Text to Legend
- Write Scale to Legend

ing, either within the cross section or outside. Again, you should be careful and pay attention to the size of the drawing field of the reporting form

Figure 14-36

that you will select for printing, as well as to the size of the cross section drawing to be placed on the reporting form.

The example shown in Figures 14-37 and 14-38 creates a legend frame 40 mm high and 30 mm wide, and positions it in the lower right corner of the cross section, with 5 mm offset from the right vertical axis and 1 mm above the lower x axis. When you make the legend frame it may not be always displayed immediately. If this is the case, you should refresh the screen display by selecting one of sizing buttons (the small arrows in the upper right corner of the window).

The next step is to write some text using the option **Write Text to Legend** from the Cross section menu. Suppose you type the word **LEGEND** as shown in Figure 14-39, then select the option **Write Scale to Legend**. Then you will select the option **Add Lithology to Legend** from the Wells menu as displayed in Figure 14-40. The dialogue box labeled **Select Lith.**

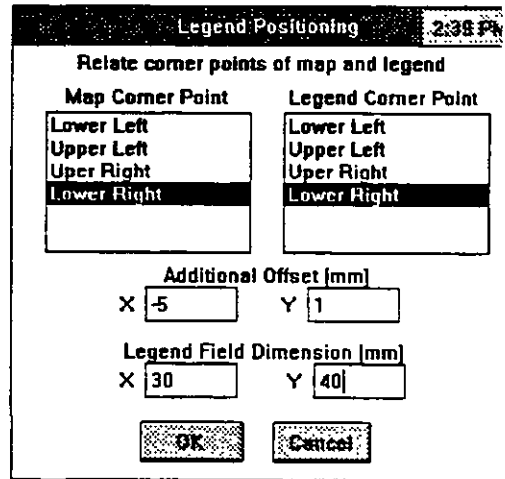

Figure 14-37

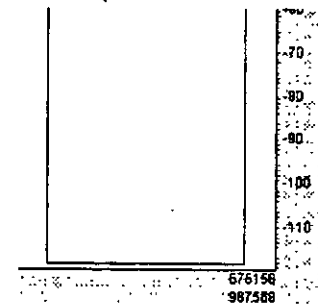

Figure 14-38

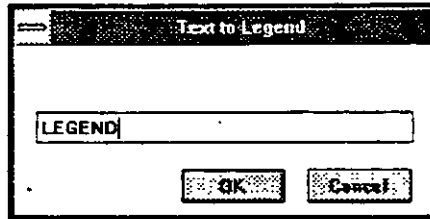

Figure 14-39

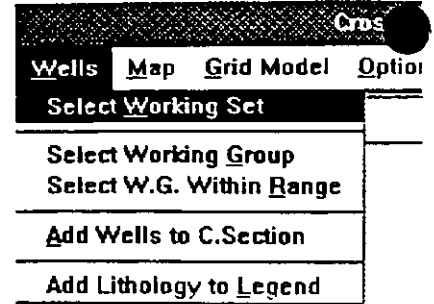

Figure 14-40

Units will list all available codes for lithology. This is shown in Figure 14-41. Since

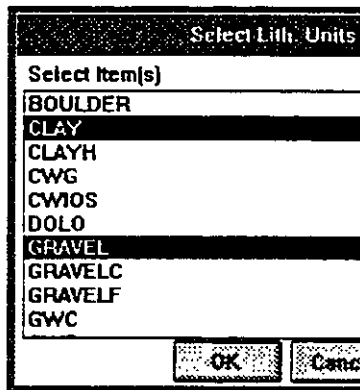

Figure 14-41

the legend block will contain codes copied as they appear in the list, you should select only the ones that have a clear description of lithology. The acronym CWIOS, which was created to present Clay With Interbeds Of Sand, will have no meaning in the legend.

The final display of the legend block may look as shown in Figure 14-42. The

lithological cross section with the legend block may look as displayed in Figure 14-43.

14.9. OPTIONS

Using Options menu you may enhance your cross section by adding well construction details and deciding on

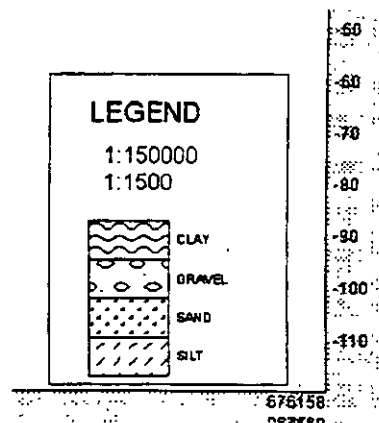

Figure 14-42

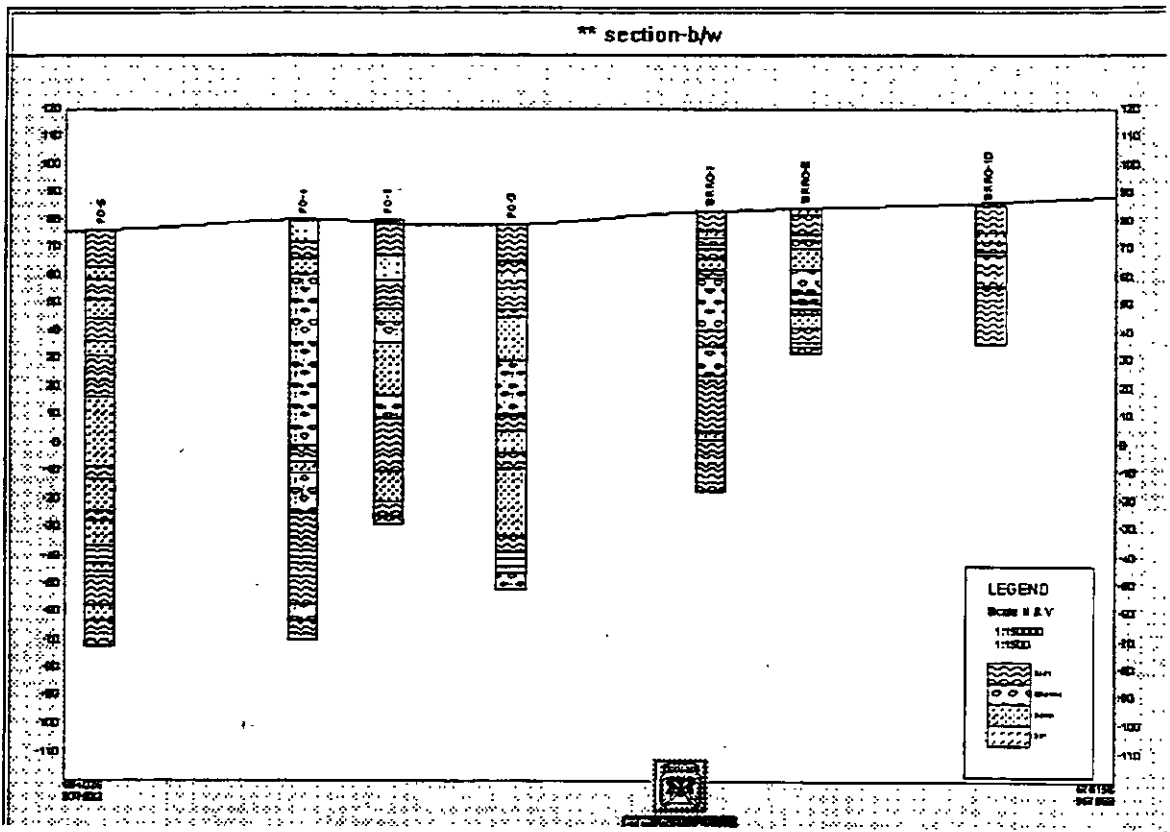

Figure 14-43

plotting one or two chemical constituents along the wells.

When you click on **Options** from the main menu, the display is as shown in Figure 14-44. You are offered to select the **Column Plotting Style** or to **Edit Chemical Concentration Parameters**. The first one is used for adding well

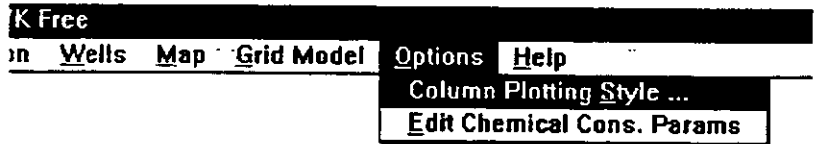

Figure 14-44

construction details an for selecting the width of vertical columns (with or without well construction).

14.9.1. Column Plotting Style

When activated this option expands to a dialogue box as shown in Figure 14-45. The box, titled **Log Plotting Style**, offers by default the horizontal scale 1:100 which can be overridden. It also offers a column width of 5 mm. You will notice a small square box with the text **Plot Well Construction**. Click on this box if you wish well construction details to be displayed.

The lower part of this dialogue box will let you select one or two chemical constituents to be displayed either on left or right side of the lithologic column. By default, none constituent is selected. However, if you wish to plot

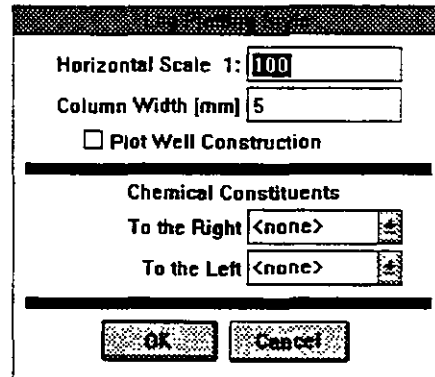

Figure 14-45

a constituent, click on the bar with arrows on either **To the Right** or **To the Left** option. GWW will open a list with all chemical constituents that you have declared in the Data Structure tool on the GWW Main menu bar for the application Concentration-Depth. One example of a list of constituents is shown in Figure 14-46.

14.9.2. Edit Chemical Concentration Parameters

The second option under the Option menu is titled **Edit Chemical Conc.Params**. It is intended to give you a chance to enhance the presentation by selecting several

attributes for each constituent to be presented. When you click on Edit Chemical Conc.Params, the dialogue box as shown in Figure 14-47 is displayed. Titled **Constituents Attributes**, it presents the list of constituents on the left side, and attributes such as Line color, Fill color, and the range of values to be displayed. You may also choose between logarithmic and linear (bar) display, and you may select the width for plotting the concentration-depth diagram on the cross section.

Horizontal Scale 1: 100

Column Width [mm] 5

Plot Well Construction

Chemical Constituents

To the Right <none>

To the Left <none>

Ca

Mg

Na

HCO3

Cl

OK

Figure 14-46

Ca

Mg

Na

HCO3

Cl

SO4

TDS

Plotting

Line Color

Fill Color

Min 0 Max 1000

Width [mm] for cross section plotting 10

Logarithmic Bar

CANCEL OK

Figure 14-47

One example of a lithologic cross section with well construction details is shown in Figure 14-48, and with chemical content diagrams on Figure 14-49. Both well construction and chemical concentration of chloride and the total dissolved solids are shown in a zoomed portion of the same cross section in Figure 14-50.

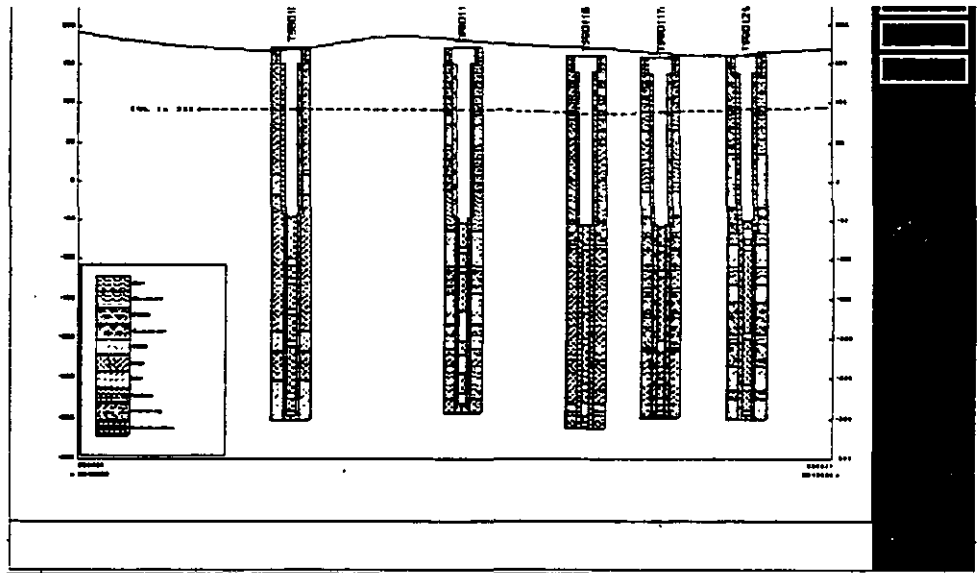

Figure 14-48

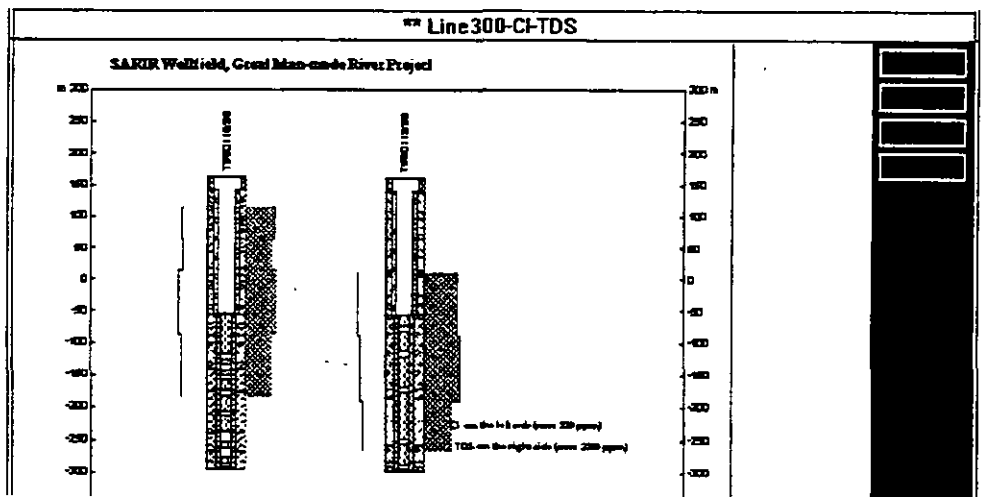

Figure 14-49

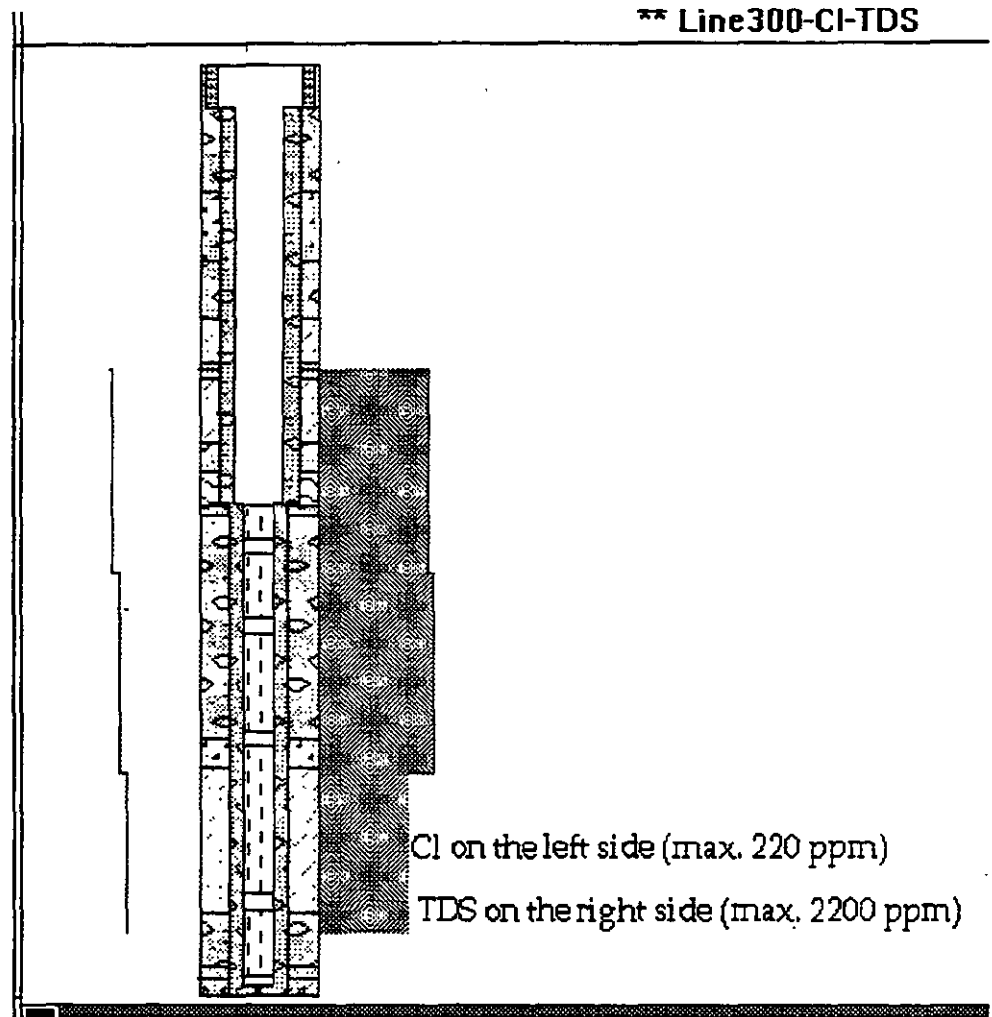

Figure 14-50

This page intentionally left blank.

15.1 INTRODUCTION

15.1.1. General Using this application you may create various thematic maps:

- Location maps with wells, sampling points, surveying points, benchmarks, etc.
- Contour line maps showing ground surface elevation, water levels, depth to water, equal transmissivity lines, TDS contour lines, contaminant contours, etc.
- Landfill and other facilities boundaries, extension of contaminant plumes, etc.

This application is a utility for creating maps, adding legends, superimposing various lines, areas, points and texts, and reporting. It uses the information from the data base, with the **Make Random** option (see Chapter Five) from other applications. It creates grid models from random points, associating a value of a distributed parameter with each cell in the model.

Location maps created in this application but based on the **Random Model** routine from other applications are used to select working sets of wells directly from the map.

15.1.2. Application's Content As shown in Figure 15-1, the Mapping application is comprised of the following major options:

- Map
- Grid
- Random

- Area
- Line
- Text
- Help

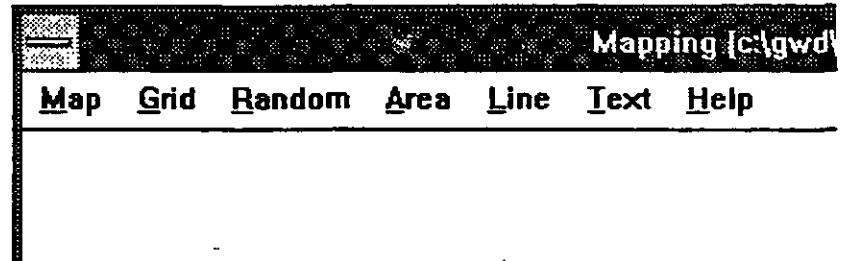

Figure 15-1

The sequence of operation is normally as follows.

1. You select a coordinate system for a new map. This means you select the range of X and range of Y values. Then you decide on the scale of the map, check the dimension of the map at selected scale. You select some attributes for the map, such as fonts, colors, etc. All this is done using the **Map** menu.
2. The next step is to use one set of random points to (a) add them and display on the map, (b) create a grid model from random points. This is done using the **Random** menu.
3. You enhance your map by adding various areas, lines, and texts. This is done using the **Area**, **Line**, and **Text** menus. In the process you are building a legend block.
4. You use the **Grid** menu to create a grid model from random points, to calculate various contour lines, and to add contours to the map. You may enhance your contour map by adding colors to certain areas.

15.2. MAP

The **Map** menu serves to create a map, to assign various attributes to the display and report, to save or copy maps, to select the scale and to check dimension of the drawing. It is also used to make a legend box with various text, including scale, and to position the legend onto the drawing.

This menu is also used to select a reporting form and to print a map.

Maps are created and saved as internal files. After you create a map, display it on the screen, and print it, you may save the completed map under its own name. Maps then become an integral part of the Ground Water Information System (GWIS). You may retrieve maps any time you open your data base, you may also print a map, or add some content.

Depending on when you activate the Map menu, some or all of the following options will be available, as shown in Figure 15-2:

- New Map
- New Map Like ...
- Old Map
- Clear Map
- Save Map
- Save Map As ...
- Make Legend
- Write Text to Legend
- Write Scale to Legend
- Edit Parameters
- Print Map

New Map	
New Map <u>L</u> ike...	
<u>O</u> ld Map	
<u>C</u> lear Map	
Save Map	
Save Map <u>A</u> s...	
Make Legend	
Write <u>T</u> ext to Legend	
Write <u>S</u> cale to Legend	
Edit Parameters	
Print Map	
Print <u>S</u> etup	
<u>D</u> imension	
Import DXF File	
Exit	Alt-F4

Figure 15-2

- Print Setup
- Dimension
- Import DXF File
- Exit

15.2.1. New Map

When you select **New Map**, the dialogue box as shown in Figure 15-3 will be displayed. It will prompt you to

define the minimum and maximum coordinates for the map, tick distance (the spacing between tick marks along axes) and scale of the map. An example of a filled in **Coordinate System Parameters**

dialogue box is

shown in Figure 15-4. It would be interpreted in the following way. The

map will originate at the lower left point with coordinates 628000,938000, and will terminate at the upper right point with coordinates 678000,970000. Ticks will be drawn on the inside of the map

Figure 15-3

Figure 15-4

border at 5000 units spacing. The scale of the map will be 1:250,000.

You will also have a chance to control the map drawing by selecting the **More** button (see Figure 15-3) which will then open another dialogue box as shown in Figure 15-5.

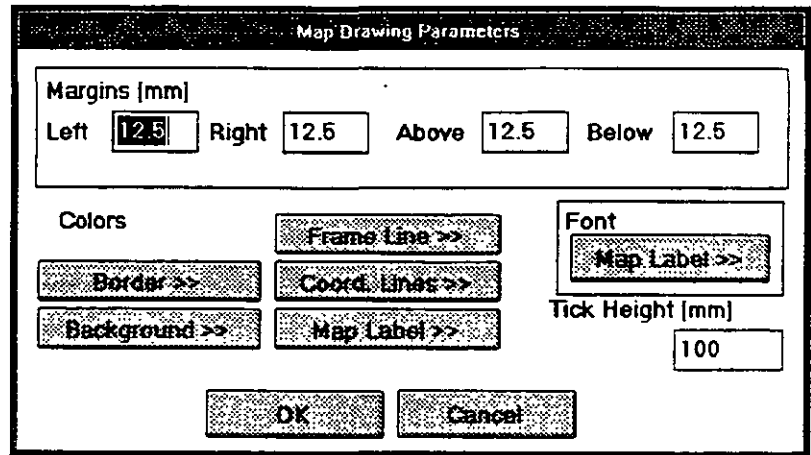

Figure 15-5

There you may control drawing margins, colors of various parts of the drawing, lines and fonts. Keep in mind, that the margins refer to the frame around the drawing, not to page margins. This is not a "fit-to-page" drawing, but rather it should fit the reporting form that you may have created using the option **Tools** from the main menu bar, followed by **Report File Editor**. You may also modify the default tick height of 100 mm.

15.2.2. New Map Like ...

Use the **New Map Like ...** option to create a new map using one of existing maps but without any content, except for coordinates of the map, scale, and drawing parameters. Actually, you will use everything from the existing map except its content. This option is useful when you are not satisfied with the map content for whichever reason. Say you wish to modify the legend, or you wish to change attributes for any line that is dis-

played. When you select this option you will be prompted to specify which one of existing maps you wish to copy, as shown in Figure 15-6. All you will see on

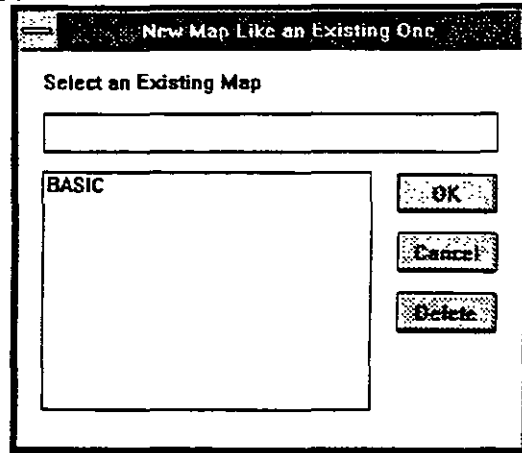

Figure 15-6

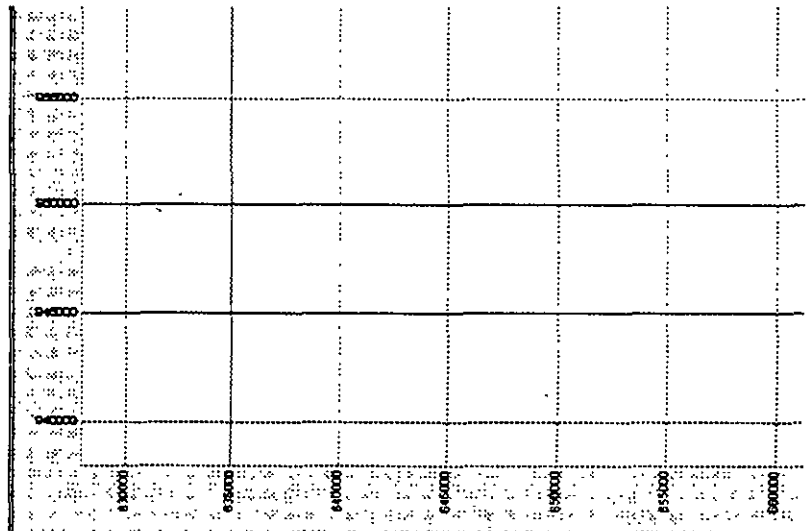

Figure 15-7

the screen will be the coordinate system, as shown in Figure 15-7.

15.2.3. Old Map

When you select this option the dialogue box similar to the one shown in Figure 15-6 will open. The GWW program displays the list with all named maps saved in previous sessions.

You will use this option when you will want to display the map, print it as it is, or modify it before printing and/or saving. When you select one of listed maps, it will be displayed on the screen. The name of the map will be displayed in the title bar on the top.



NOTE. Always look at the title bar to see with what you are currently working. This helps to prevent accidental changes, unwanted saving and overwriting.

15.2.4. Clear Map

This option clears the content of the currently selected map. What remains is the coordinate "system", that is the X and Y coordinate axes, scales, and attributes. If you keep working with this "cleared" map and save it under the same name, that is by selecting option **Save Map**, the previous content will be erased ("cleared") and the new content will be saved instead.

15.2.5. Save Map

When you finish working on a map you may want to save it. You have two options: (1) to save it under the name that is displayed in the title bar, (2) to save it under a different name. The option **Save Map** saves only under the same name as shown in the title bar. If this is an untitled map, that is a new map, this option will be dimmed, which means unavailable.

15.2.6. Save Map As ...

When you work on a new map, this will be the only "saving" option available. You will be prompted to assign an internal map name. If you worked with an existing map (you used the option **Old Map**), you will have the option to save it by selecting either **Save Map**, in which case the same map title will be kept and its content overwritten, or by using the option **Save Map As ...**, in which case you will assign another name to the modified map without affecting the content of the one you started with. In this second case the dialogue box similar to the one shown in Figure 15-6 will be displayed.

15.2.7. Make Legend You will notice a block of options on the **Map** menu, Figure 15-2, on the **Grid** menu, Figure 15-11 (Add to Legend), and on the **Random** menu, Figure 15-26, on the **Area** menu, Figure 15-40, and on the **Line** menu, Figure 15-46.

The legend will normally consist of some text, scales, various points, contours, additional lines, such as rivers, roads, landfill facilities, mines, etc. Using this option, you may position the legend box onto the drawing, assign its X and Y size, and add some offset to the frame to move it from the drawing's frame.

The option **Make Legend** on the **Map** menu prompts you to select the relative position of the legend frame within the drawing. The dialogue box is displayed in Figure 15-8. With a little bit of patience you may place the

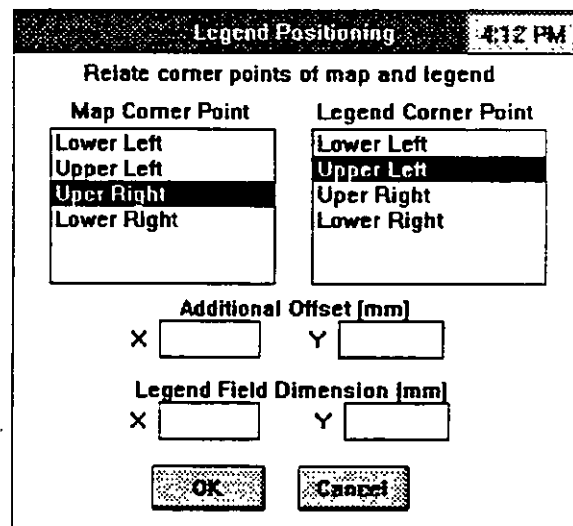

Figure 15-8

legend frame to any place on the map drawing, either within the map or outside. You should be careful and pay attention to the size of the drawing field of the reporting form that you will select for printing, as well as

to the size of the map drawing to be placed on the reporting form.

For examples on how this may work see Chapter 14, Cross Sections.

- 15.2.8. Write Text to Legend** You may write some text to the legend, line by line. Each time you select this option, you will be prompted for text and for fonts for the text. The text lines will be printed in vertical succession from top to bottom within the legend frame you designed using the option **Make Legend**.
- 15.2.9. Write Scale to Legend** Using this option the program will add the scale for the map to the legend.
- 15.2.10. Edit Parameters** You may edit the parameters of an existing map. When you select this option, the dialogue box as shown in Figure 15-4 will be displayed. You may modify anything in this box, although normally, you will probably want to change the scale, the tick distance, and one or more map drawing parameters. Remember the **More** option (button) opens another dialogue box in which you control drawing parameters, Figure 15-5. The normal procedure in editing map parameters would be to select the scale and then check the dimension (size) of the map by selecting the option **Dimension** from the same menu. The display may look as shown in Figure 15-9. If not satisfied,

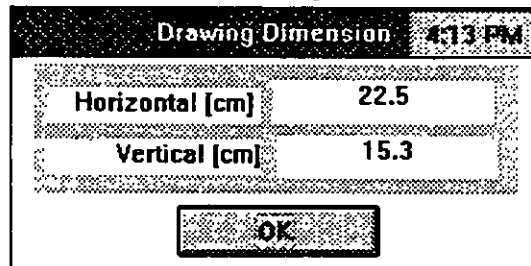

Figure 15-9

you may return to the **Edit Parameters** option and modify the scale.

15.2.11. Print Map When you decide to print a map, the program will display the list of all the available reporting forms. You may select one of the forms, and the program will print the report. In the Mapping application, there are two default forms: landscape and portrait.

15.2.12. Print Setup This option is explained in Chapter 5, Section 5.4.

15.2.13. Dimension As mentioned earlier in paragraph 15.2.10., you will use this option frequently to check the size of the drawing. The numbers, which are in centimeters by default, as shown in Figure 15-9, include drawing margins. The following is important to keep in mind. Maps are printed using either a default reporting form or one which you created. When you create a reporting form, you assign the dimension and position of the drawing field. The dimensions assigned using the **Tools** option on the main menu and **Report Form Editor** should match the dimensions of your current map in order to print its whole content.

For example, you currently have a map reporting form which is prepared for the drawing size 250 mm horizontally by 154 mm vertically in landscape orientation, and 180 mm horizontally by 250 mm vertically in portrait orientation. If your drawing's dimensions, as displayed using this option, are less than the reporting form's drawing field, the map will be centered within the drawing field. If they are greater than the drawing field, a portion of the map will not be printed. What will be printed will start at the lower left corner of the reporting form's drawing field.

15.2.14. Import DXF File

One of the features of the GWW package is that it allows files to be imported from other major graphics programs. One standard is the *Drawing Interchange File*, or DXF format, produced by Autodesk for AutoCAD and supported by most CADD programs. Only selected objects from a DXF file will be imported. GWW eliminates three dimensional

.DXF images. Normally, it will import two-dimensional contour lines, other lines such as roads, rivers, and the like, and some limited text. When you select this option, the program will display a dialogue box such as the one shown in Figure 15-10 prompting you to select a file with a .dxf extension. The program will then translate the file and display the range of X and Y coordinates and the range of Z values for contouring on the screen.

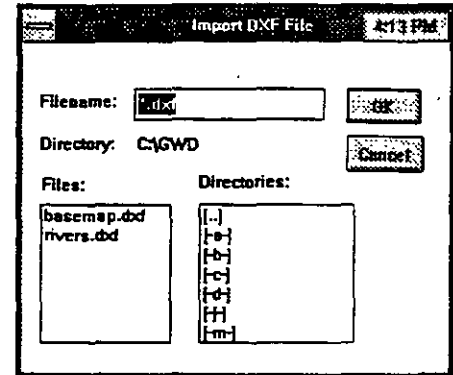

Figure 15-10

If you do not have a new map displayed on the screen, this is all that you will get from an imported .DXF file. However, if you know the range of the X and Y coordinates and have created a new map before importing a .DXF file, the GWW program will translate the .DXF file and plot the contours onto your map.

On the distribution diskette you will find one example with a .dxf contour file labeled as basemap.dxf. This is a direct output file from AutoCad. To reproduce the map do the following:

1. From the Mapping application menu select Map.

2. Select **Import DXF File**. As shown in Figure 15-10 double click on the file name `basemap.dxf`. There will be a window showing the current operation, which is reading the file, line by line. It is a huge file, and it will take some time to read it all. When the reading is done, there will be a window displaying the range of the values of the X and Y coordinates, as shown in Figure 15-11. The range for the X coordinate is from -9275.2 to 14642.41, and for Y coordinate it is from -5199.09 to 13384.33.

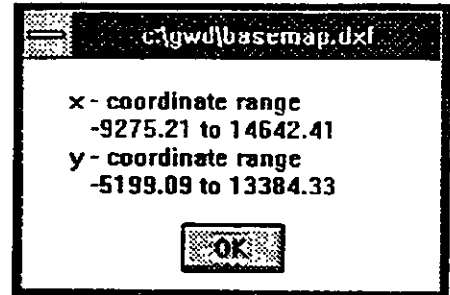

Figure 15-11

3. Remember the ranges of X and Y values. Go to the **Map** menu and select **New Map**. Fill in the dialogue box with the following values: X Coordinate from 12000 to 13200, Y Coordinate from 4000 to 4800, Tick distance 100, Scale 10000. Wait until the map coordinate system is displayed.
4. Select the **Dimension** option from the **Map** menu. Confirm the size of 14.5 by 10.5 cm for selected scale and selected range of coordinate values.

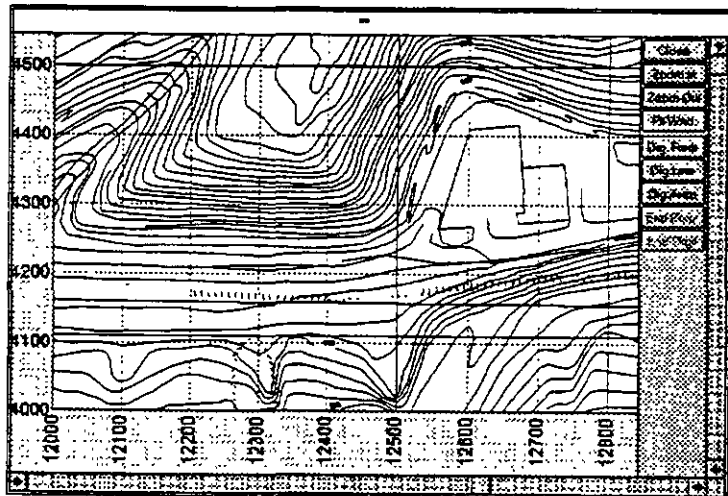

Figure 15-12

5. With the map coordinate system still on the screen, select again **Import DXF File**. The procedure in step 2 will be repeated but the program will continue with plotting the map content, that is contour lines, roads, etc. When you zoom into a portion of the map, it may look as shown in Figure 15-12.

15.3. GRID MENU

15.3.1. Content

Contour maps require data to be in a special regularly spaced format before such maps can be generated. Gridding is the process of taking random data (or data at random points) and through interpolation and extrapolation converting the data to the regularly spaced form, which is then used to create a surface representation. Gridding is the heart of the Mapping application program.

Remember that the term GRID may imply an empty model on one hand, or a grid model in which every node has an associated "Z" value on the other hand. The "Z" value can be ground surface elevation, static or any water level, depth to water table, total dissolved solids, thickness of an aquifer, elevation of a stratigraphic contact, concentration of a contaminant, transmissivity of an aquifer, and much more.

The term model implies a rectangle made up of rows and columns. The gridding routine attempts to interpolate a "Z" value at the intersection of each row and column. This intersection is called a node. Smoothness of the final contours is normally a function of input data, grid density, and search parameters which are built into the program. You may override this last parameter by assigning more or less importance to distant points.

The second option on the application's menu bar, **Grid**, is comprised of the following, as shown in Figure 15-13 (notice that not all options on this menu are available at all times):

- New Grid
- New Grid Like ...
- Old Grid
- Save Grid
- Save Grid As ...
- Edit
- Add Contours to Map
- Add Color Regions to Map
- Add Area to Map
- Add to Legend
- Make Grid from Random
- Make Contours
- Make Color Regions
- Set Subgrid Area
- Get Subgrid Area
- Clear Subgrid Area
- Standard ASCII I/O
- Output to DXF File

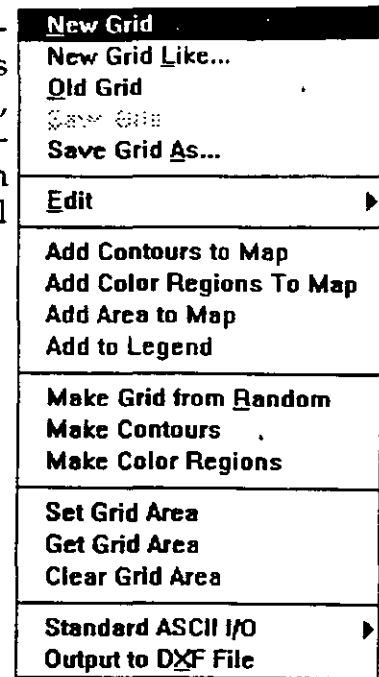

Figure 15-13

You use the **New Grid** option in the same manner that you use the **New File** option. You will be prompted to define the model, that is its origin (X_0 and Y_0), which by

definition is in the lower left corner of the grid, grid size and number of rows and columns. The dialogue box displayed in Figure 15-14 defines the following:

Figure 15-14

- Xo and Yo** Minimum X and Y coordinates of the grid model;
- Dx and Dy** The distances in units of length (meter, feet, etc.) between X and Y grid lines, respectively;
- Nx and Ny** Number of grid lines in the X and Y dimensions.

The number of grid lines in the X and Y dimensions must be a positive integer (without a decimal point) greater than one. The distance in data units between the X or Y grid lines may be a positive real quantity (with a decimal point). For square grid cells, the Dx and Dy values should be equal. It is expected that the interpolation process will be finer, smoother or better when the number of grid lines is increased and the distance between lines reduced. However, the process of calculating contours takes longer.

One example of grid parameters is shown in Figure 15-15. The model covers an area from X minimum 628000 to X maximum 678000; that is 50 km since the data unit is meters, and from Y minimum 938000 to Y maximum 970000, that is 32 km. The discretization of the space is done with 50 columns and 32 rows, each of 1000 m length. Thus the model cells are squares of 1 km^2 each.

Figure 15-15

- 15.3.2. New Grid Like ...** When you select this option only the grid parameters as displayed in Figure 15-15 will be copied from the selected grid, not the "Z" values which are normally associated with each grid cell. Using this option you accept the same size, spacing and density of the grid model, and intend to use it for creating a grid model of another "Z" parameter. The dialogue box such as the one shown in Figure 15-16, offers you a list of all available grids.

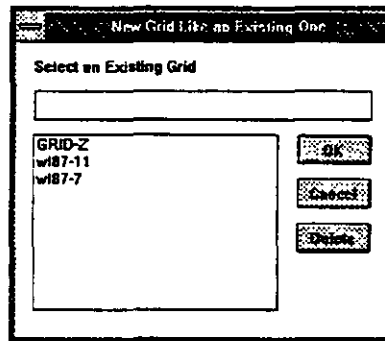

Figure 15-16

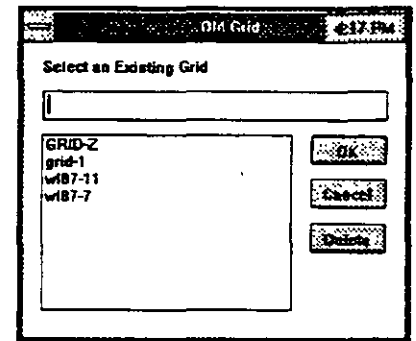

Figure 15-17

- 15.3.3. Old Grid** You will select an existing grid to make contours or to add color regions to your map. The dialogue box, such as the one displayed in Figure 15-17; will display the list of available grids.
- 15.3.4. Save Grid** When you select an existing grid and use it for whatever reason (the most obvious one is to make contours, display them and print the contour map), you may save it under the same name as the one you used to select the grid. You may modify the grid by reducing the distance between the X or Y lines, or modifying the grid coverage by changing the number of cells in X and/or Y dimension. Whatever modification you make, you may save the grid under the same name. This command will change the grid to reflect any changes you have made to it. If the grid you are working on has not previously been named (e.g. you are creating a brand new grid), GWW

displays a dialogue box that lets you enter a name and path.



NOTE. The grid names are internal file names, not ASCII files. You may create equivalent ASCII files using another option on this menu.

15.3.5. Save Grid As ...

By using this command to give your grid a different name from what it had, you can save the current (changed) version without disturbing the original version. The name should be different from any other file; otherwise you will replace the file that already has that name. This option displays the Filename dialogue box similar to Figure 15-16 or Figure 15-17. Enter a name and path and click on OK, and GWW creates another internal file with that name. When you resume working, you are working in the new grid.

15.3.6. Edit

The option Edit on this menu opens up with additional options. These options are shown in Figure 15-18. The major options for editing are:

Figure 15-18

- Edit Grid Parameters
- Edit Contour Levels
- Edit Contour Attributes
- Edit Color Intervals

15.3.6.1. Edit Grid Parameters

Using this option, you are given another chance to modify grid size, coverage and density. The dialogue box, such as the one shown in Figure 15-15, will be displayed. Remember that by editing, that is, changing grid parameters of an established grid, you are losing its content. In other words, for any change you need to make the grid again ('Make Grid from Random').

15.3.6.2. Edit Contour Attributes

After you select **Edit Contour Levels**, the program allows you to select **Main Contours** or **Auxiliary Con-**

tours to edit, as displayed in Figure 15-19. In the terminology of some other contouring packages, these options are equivalent to Labeled and Unlabeled contours. Main or labeled contours will contain in-line contour labels.



Figure 15-19

Whichever contour you select, main or auxiliary, GWW will open a dialogue box giving you an opportunity to modify or control almost every attribute of a contour line. This is normally line thickness, line pattern (solid, dashed, dotted, or combinations), line color, fonts for labels, etc. The display is the same as shown in some earlier figures, such as Figure 14-31 in Chapter 14.

15.3.6.3. Edit Contour Levels

GWW assigns some default minimum and maximum contour levels and contour intervals, depending on the range of the "Z" values found in a grid. However, this may not be what you want to use. After you select **Edit Contour Levels**, GWW will display the dialogue box as shown in Figure 15-20. You may now edit either main levels or auxiliary levels, or one after the other.

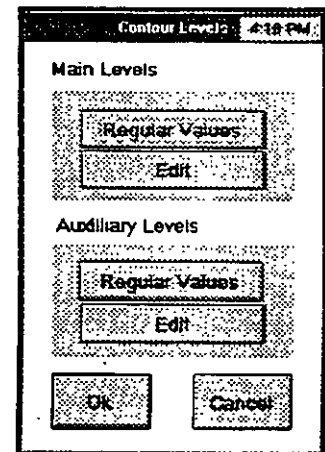

Figure 15-20

If you select the **Regular Values** option, GWW will open another dialogue box as shown in Figure 15-21. There you should specify the minimum and the maximum contour line levels and the step. The program will then make contours at equally

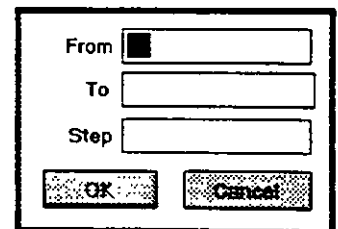

Figure 15-21

spaced intervals using the step you supplied in this box.

If you wish to specify discreet contour levels for plotting, rather than equally spaced intervals, use option **Edit** and specify an irregular number of data units between contour lines. Contour levels do not have to be in any specific order, or equally spaced. One example of editing contour levels is shown in Figure 15-22.

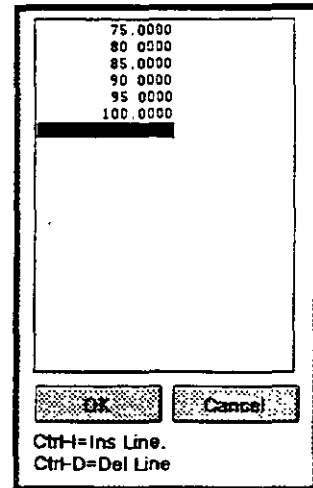

Figure 15-22

15.3.6.4. Edit Color Intervals

This option is used to specify color intervals and color values for various intervals. The option will have sense only if you wish to print a contour map enhanced with color intervals. For this you need a color printer. When you select this command, the display will be as shown in Figure 15-23. The program has preselected some default

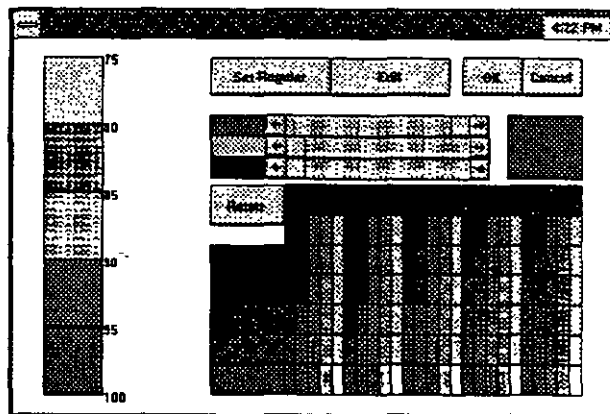

Figure 15-23

intervals for you and has assigned a palette of colors to each interval. You may override this by clicking with the mouse any interval you wish to modify and by clicking on a color from the color palette displayed in this dialogue box. You may also edit intervals for coloring. Just as in the option for setting contour levels you have two options: (1) **Set Regular**, or from the minimum contour level to the maximum, and assigning some uniform level step; (2) **Edit**, in which case you type any interval you wish.

15.3.7. Add Contours to Map

This command is interpreted by GWW as a combination of two commands:

- Make contours, and
- Add contours to the map

The program calculates contours from the currently selected grid file, using the currently selected contour levels and contour attributes and draws the contours into the map, displaying the same.

This option will be available only if you have selected a grid with values at the intersection of each column and row. In other words, you must have used the option **Make Grid from Random Points** either during the current session or earlier.

15.3.8. Add Color Regions to Map

This command is interpreted by GWW as a combination of two commands:

- Make color regions, and
- Add color regions to the map.

It will be available only if you have selected a grid with values at the intersection of each column and row. In other words, you must have used the option **Make Grid from Random Points** either during the current session or earlier.

15.3.9. Add Area to Map

This option is added to the **Grid** menu for convenience. *Areas* will be explained further in Section 15.5. Although you may create many areas, that is, closed lines that encircle a certain portion of the map, and give them different names, only one area can be selected as the current area. You may add this area to the map in this menu or in the **Area** menu. In the latter you may edit plotting parameters, make an area transparent or not, assign different line patterns, colors, etc.

15.3.10. Make Grid from Random

This is one of the most important routines in creating a contour map. Before you can make a grid from random points, you must select a random model. The **Random Model** menu is discussed in Section 15.4. and its subsequent paragraphs.

This is a command which interpolates and, if necessary, extrapolates values of the "Z" parameter from discrete random points to the regular model grid. To make it work you must have a currently selected random model and a currently selected grid. If one of these two is missing, this command will not be available.

If you do execute this command, you may use its results to create a contour map, to save the grid selected but now with associated values at the intersection of each column and row in the model, or you may save the grid in an ASCII or .DXF file.

15.3.11. Make Contours

This is also a command which will be available only if you have selected a grid which has calculated values at the intersection of each column and row. The command will not display contours by itself. For this you need to activate the command **Add Contours to Map**, as explained in 15.3.7.

15.3.12. Make Color Regions This is also a command which will be available only if you have selected a grid which has calculated values at the intersection of each column and row. The command will not display color regions by itself. For this you need to activate the command **Add Color Regions to Map**, as explained in 15.3.8.

15.3.13. Set Subgrid Area This command is used to make contours within one or more closed areas. It is equivalent to blanking specified portions of a previously created grid. You may blank inside or outside the subgrid area. The subgrid area is an area digitized by you using the Area menu or input as an ASCII file also from the Area menu. If the area was digitized using a clockwise direction of digitizing points, the area outside of the subgrid area will be blanked and contours and/or color regions will be applied only to the interior of the subgrid area. The opposite is also true.

A subgrid area may contain more than one area. You will learn in Section 15.5.2 to create an area file with more than one area. You may also create subgrid areas using a digitizing program or a text processor from outside the GWW package. A portion of a subgrid area, saved as an ASCII file, is reproduced below.

```

2396063.0000000    403318.6875000
2396602.0000000    403703.6875000
2397164.2500000    403684.4375000
2397333.5000000    402960.6562500
2396552.0000000    402594.9062500
2396070.7500000    402879.8125000
2396063.0000000    403318.6875000
/*
2397834.0000000    403703.6875000
2398492.5000000    403850.0000000
2398769.7500000    403195.5000000
2398045.7500000    402779.6875000
2397718.5000000    403368.7500000
2397834.0000000    403703.6875000
/*

```

This subgrid area file is composed of two closed areas, the first with 6 different points, and the second with 5 points. The digitizing was in a clockwise direction. If this area is "set," the contours will be produced in these two closed areas only.

15.3.14. Get Subgrid Area

You may have more than one subgrid area within which you wish to contour. With this command you will be prompted to select one of the available subgrid areas. This is a combination of commands: select and set a subgrid area.

15.3.15. Clear Subgrid Area

When you wish to contour within the entire rectangular grid which is specified by the currently selected grid, and you have previously set a subgrid area for contouring within a closed area, you will use this command to remove the subgrid area and return to contouring within the rectangular grid.

15.3.16. Standard ASCII Input/Output

You may save a grid model in an ASCII file or input the grid model from an ASCII file. This file could have been created by GWW or by any other program, e.g. by SURFER™. When you select this option the menu option expands to two options: **Input** and **Output**, as shown in Figure 15-24. You will select **In-**



Figure 15-24

put if you wish to read an existing grid model from an ASCII file, or **Output** if you wish to write the grid model created by GWW to an ASCII file. A portion of the ASCII file with the grid model is reproduced below.

75.9089	75.9592	71.7994	71.9027	72.0099
71.6541	71.2471	71.3617	71.1524	71.2424
71.3354	71.4302	71.5275	70.4314	70.5159
70.7258	70.9576	71.2168	71.5073	71.3087
71.6741	70.9735	73.8004	75.6722	75.8195
75.9486	76.0329	76.0291	75.5818	75.0766
74.4473	73.7384	73.0179	72.3480	71.7709
71.2997	70.9180	70.6734	70.4999	70.3836
70.3149	70.2850	71.5821	71.7099	67.9782
67.9463	67.9067	67.8712	67.8304	67.7950
75.8668	75.9182	71.8866	71.4863	71.6143
71.7295	71.3211	71.2226	71.3183	71.4164
71.5158	71.6163	70.4442	70.6280	70.7216

The grid is the same as shown in Figure 15-15 with 50 columns and 32 rows. GWW writes five numbers in each line of the ASCII file. The format is free, that is numeric entries are separated by one or more spaces or a comma. The first ten lines of this file represent "Z" values for row one. Remember that the model is made of 50 columns and 32 rows. The ASCII file should contain 320 rows, since each row is written in ten lines, each with five numbers.

When you decide to write a grid model into an ASCII file, the program will give you two options for the order of writing the numbers:

1. From the minimum Y value to the maximum Y value, that is from row 1 to the last row, which is row 32 in this example. This is a normal way of writing the file, the one which follows the standard convention of the coordinate system with the origin in the lower left corner.
2. From the maximum Y value to the minimum Y value, which places the origin of the coordinate system into the upper left corner of the model. This is the input required for most of currently used ground water mathematical modeling software including the U.S.G.S. MODFLOW, the United Nations GWMOD, and others. With this option in GWW, you may create input data files for your modeling software.

15.3.17. Output to DXF File

You may also export the grid model as a .DXF file. The values exported are the coordinates of the intersection of each row and cell and the "Z" value associated with each intersection. You may input such files in AutoCad and create a three-dimensional contour map. Before GWW creates a .DXF contour file, you will be asked to select which layer you wish to have written to the file. The term "layer" refers to the "Z" parameter, which could be one of many with which you have created grid models. Normally, this may be the ground surface elevation, one of water level elevations or depths, or any other numerical space-distributed parameter.

When you select this option you will be prompted to select a file name, as shown in Figure 15-25.

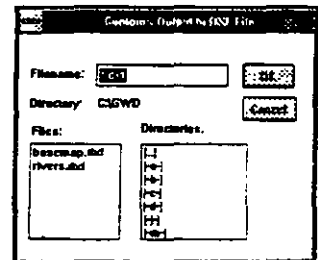

Figure 15-25

15.4.

RANDOM MENU

The Random menu options and commands are shown in Figure 15-26. With this menu you may input one of the existing random models which you may have created using any GWW applications or which you may have imported as ASCII files created within or outside of GWW.

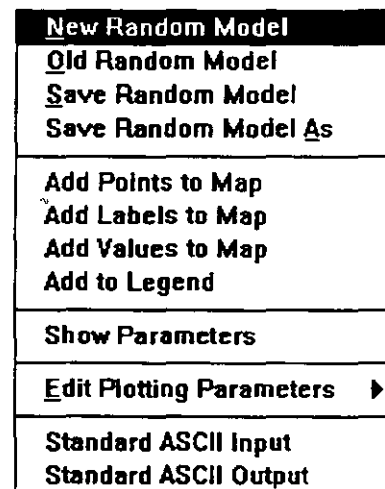

Figure 15-26

This menu is used to create location maps displaying various points or wells. If you wish to add contour lines to such maps you need to use the **Grid** menu. To add lines you will use the **Line** menu, to add areas you will use the **Area** menu, and to add text you will use the **Text** menu.

15.4.1. New Random Model

Random models are created in applications other than mapping. Random models are internal files containing for each point its X and Y coordinates, the "Z" value which could be any numerical distributed parameter, and the well or point identification name or number. It will be easier to understand a random data file in an ASCII format. One of such files is partially reproduced below.

657900.0	949000.0	6.630000	PO-1
660000.0	953500.0	7.450000	PO-2
657800.0	945300.0	7.570000	PO-4
654500.0	941000.0	6.640000	PO-5
675800.0	962300.0	5.000000	SRRG-10
665000.0	958000.0	13.71000	SRRG-7
.....			
669000.0	959200.0	11.32000	SRRG-8

The first column is the X coordinate of the point, the second column is its Y coordinate, the third column is its "Z" value, which in this case is the depth to water table from a measuring point. The last column is the well identification.

You may create such files using any other software, not necessarily the GWW package. The format of data is free, that is column values are separated by one or more spaces.

You are advised to always start with this option since whatever you input as random points will simply add to whatever you may currently have in the memory for random models. By selecting **New Random Model** you guarantee that your next step, the selection of an old ran-

dom model, or a standard ASCII file input with a random model will not mix with an existing random model.

When you select **New Random Model** you will be prompted to answer several questions, such as **Coordinates Unit**, and **Is Z-value dimensioned**, and to select type of units and unit for Z values.

15.4.2. Old Random Model

If you have used **Random Model** in any other application of the GWW package, you have created one or more random models to which GWW has given internal file names. Using this option, you will be prompted to select an existing random model. The dialogue box is as shown in Figure 15-27. In this example we have used master data applications to create a random model with

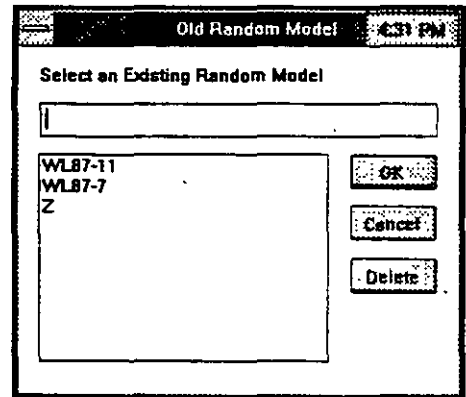

Figure 15-27

all wells of which the ground surface elevation is known (Z random model), then we used a hydrographs application to create two random models for water levels in July 1987 (WL87-7) and in November 1987 (WL87-11). The names of these models are the ones we have selected.

If you have not created any random model in any application, you cannot use this set of routines. You will have nothing to plot.

When a random model is input, either internally or as an ASCII file GWW will inform you about random model limits for the X and Y coordinates and for the "Z" values. One of examples of this information box is shown in Figure 15-28. Notice that random models are dimensioned, that is the coordinates are either meters or feet, and Z-values are either dimensioned or nondimensioned.

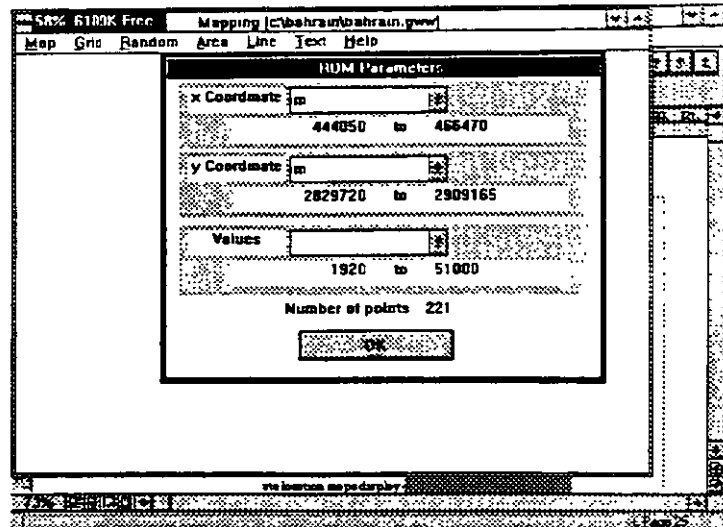

Figure 15-28

15.4.3. Save Random Model

This routine is used only when you wish to input a random model ASCII file and save as an internal file within the GWW data base. Normally you would input an ASCII file, which will contain the following information: X, Y, Z, well identification. You will then save this model under an internal GWW name when prompted for this as shown in Figure 15-29.

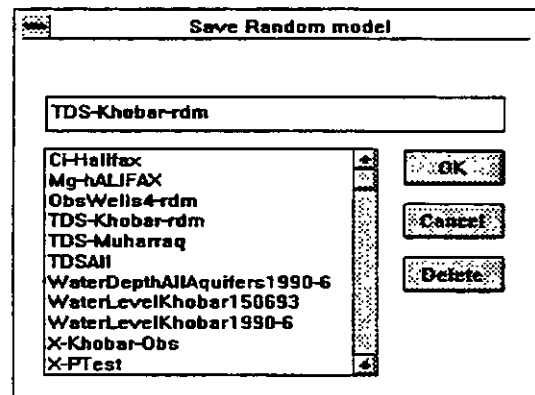

Figure 15-29

15.4.4. Save Random Model As

You may save a currently used random model under the name of an existing random model. This will replace entirely the content of the internal file which contains a random model. It is important to understand that you may not have more than one random model open at a time.

15.4.5. Show Parameters

This is the option which displays only the range of values for X and Y coordinates and the "Z" value. One example is shown in Figure 15-28. You cannot edit these values. They serve only as a reminder and as a check that this is the model that you wish to work with.

15.4.6. Edit Plot Parameters

When you select the option Edit Plot Parameters, you will be given a choice of three entries as shown in Figure 15-30:



Figure 15-30

- Point
- Label
- Value

For points, you may select one of 14 symbols and choose the size, as shown in Figure 15-31. With some imagination and repetition,

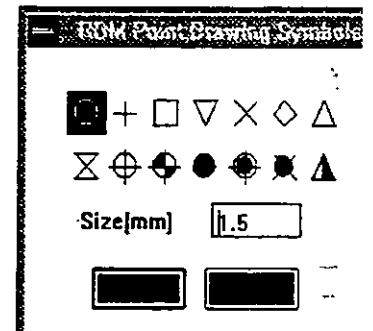



Figure 15-31

Figure 15-32

 you may create various symbols using these 14 pre-designed symbols. One possible combination is shown in Figure 15-32. For Label you may select fonts, colors and alignment,

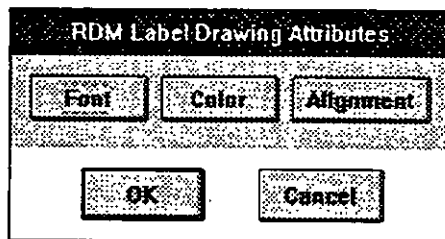

Figure 15-33

as shown in Figures 15-33, 15-34, and 15-35, respec-

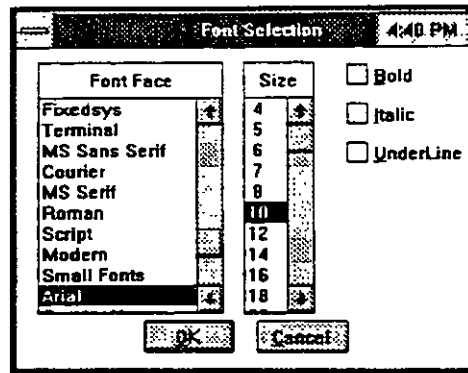

Figure 15-34

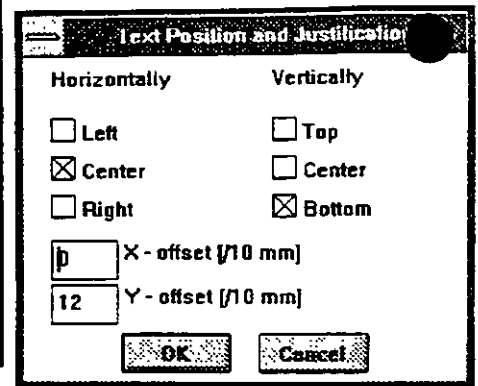

Figure 15-35

tively. Likewise you may select fonts, colors and alignment for values. This is shown in Figure 15-36. The attributes you choose apply only to plotting and creating a location or contour map.

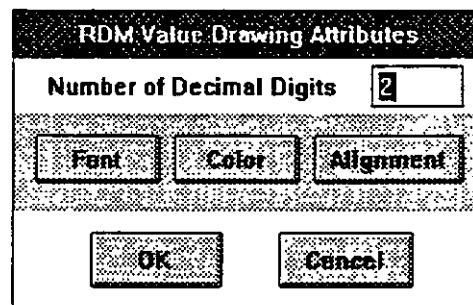

Figure 15-36

15.4.7. Add Points to Map

With this command the points from the currently "active" random model will be plotted. You control the size and symbol for points by using the option **Edit Plot Parameters** followed by **Points**.

- 15.4.8. Add Labels to Map** Labels will be plotted on top of the symbol for points. It is understood that you have previously used the option **Edit Plot Parameters** and selected fonts, colors, and alignment for labels. Horizontal and vertical alignment attributes will control the position of labels with respect to the position of symbols for points.
- 15.4.9. Add Values to Map** Values will be plotted to the right of the symbol for points. It is understood that you have previously used the option **Edit Plot Parameters** and selected fonts, colors, and alignment for values. Horizontal and vertical alignment attributes will control the position of values with respect to the position of the symbol for points.
- 15.4.10. Add to Legend** With this option you may add one point to the map legend. The point will be copied to the legend block with the same attributes as the one used for its plotting. This applies to font, color, alignment of its label and value..

You will first be prompted to specify one of the labels that will be copied to the legend, as shown in Figure 15-37. Then you will be prompted to type some text that defines values plotted on the map. For example, you may type the text as "Depth to water table in July 1987", or "TDS in ppm," or "Toluene content in ppm," etc.

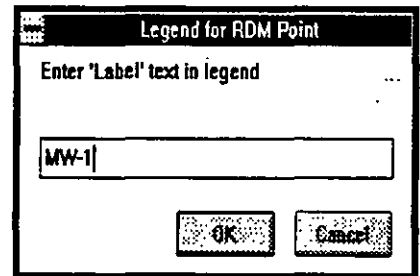

Figure 15-37

15.4.11. Standard ASCII Input

As mentioned earlier, you may input a random model importing an ASCII file. This file could be created from another software program or use a text processor. It is

important to remember the order of input variables: X coordinate, Y coordinate, Z value, well identification. The format is free.

When you select this option the GWW program will display a list of files with the extension .rdm. You may select any file giving the path and file name. This is shown in Figure 15-38.

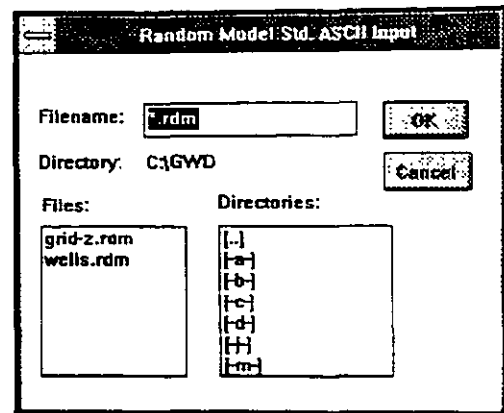

Figure 15-38

15.4.12. Standard ASCII Output

You may also save a random model which was created in another GWW application. This is useful for backup, or when you wish to merge information and import the model back to GWW. When you select this option the program displays a dialogue box with a list of files with the extension .rdm. One example is shown in Figure 15-39.

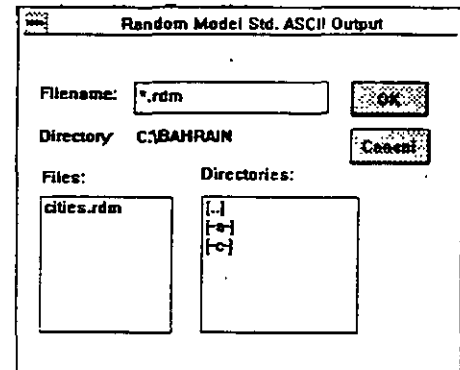

Figure 15-39

15.5. AREA MENU

The Area menu is used to digitize an area, which will be used for contouring within or outside its boundary, or which will be simply plotted onto the map. With this menu you may create or import more than one area, save such areas under internal file names, edit plotting parameters, etc. The menu options are listed in Figure 15-40.

New Area
Old Area
Save Area
Save Area As
Add Area to Map
Add to Legend
Edit Plot Parameters
Standard ASCII Input
Standard ASCII Output
DXF Output

Figure 15-40

15.5.1. New Area

The GWW package adds new areas to currently present areas. In order to have a clear "area" space you should use the option **New Area** prior to creating or importing an area. You will see no visible action after you select **New Area**, but the "area content" will be emptied if there were another area in it.

15.5.2. Digitizing Area

The GWW package incorporates digitizing capabilities when it comes to creating areas and lines. When a map is displayed you will notice a vertical row of buttons. For digitizing an area, the following buttons are important: **Dig.Area**, as shown in Figure 15-41, and **End Point** and **End Digit**, as shown in Figure 15-42.



Figure 15-41

When you wish to digitize an area directly on the map (more correctly, on the screen display), you should proceed as follows:

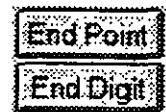

Figure 15-42

1. Select the button **Dig.Area** on the right side of the map. This will place the program into the digitizing mode.
2. Move the cursor to a point where you wish to start the area. Press the left mouse button. Move the cursor to the second point and click the mouse. Be careful here. If you are going to use this area as a closed area within which you wish to later make contours, digitize in a clockwise direction. If you wish to do the opposite, to contour outside the area, digitize in counterclockwise direction.
3. When you finish digitizing, you are expected to be close to the point you started with. Remember, an area must be a closed area. However, since it is not possible to manually duplicate two points, the initial and final, the program will do this automatically when you terminate the digitizing input by clicking on the button **End Point**.
4. You have now two options. Either to finish digitizing, as what you wanted was one single area, or to create another closed area.

If you wish to finish digitizing, you should click on the button **End Digit**. With this you will get out of the digitizing mode and return to the area menu. Your current "area content" will contain the X and Y coordinates of all points that you have just digitized. You may save these points in an ASCII file, using the option on the same menu **Standard ASCII Output**, or you may save the points in a DXF file using the option **DXF Output**. But most of all you may save this area with all points, making the area an internal data base file using the option **Save Area** or **Save Area As**.

After you have terminated the first area by clicking on the **End Point** button, you may create another area by clicking on a point which is on the second area's boundary. Continue clicking on other points and finish the second area by clicking **End Point**. If this is the last area you wish to digitize, press on **End Digit** to get out of the digitizing mode.

If you have digitized more than one area, however, all of them are internally saved as one digitized area file. Each area will be defined with same attributes: line thickness, line color, line text, text fonts, etc.

You will notice other buttons on the right side of the map as shown in Figure 15-43. These are standard options on any of the Mapping application display or menu. You may always zoom in or out, or **Fit to Window**. It may help to digitize an area in a zoomed in display.

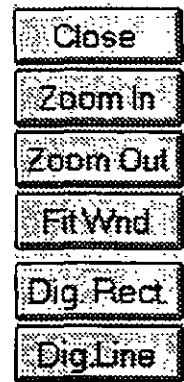

Figure 15-43

15.5.3. Old Area

You may create one or more areas by direct digitizing, or you may import areas as ASCII files. You may assign to these various internal names, such as Landfill cell A, ore-body CW, Tailings cell G, etc. Each may be identified with its own attributes. All these areas are stored within the information system, and are not currently transferred into the current "area content."

When you wish to pick one of the available areas and place it into the current "area content," you should select the option **Old Area**. The GWW program will display a list of the available internal file names. You may select one. The selected area becomes your current area. You may edit the area's attributes, plot the area onto the map, or use it for contouring, making it a grid area.

15.5.4. Save Area and Save Area As

Whether you have created an area by direct on-screen digitizing or have imported an area as an ASCII file you may save it under an internal file name to make the area a part of the GWW data base or information system. The difference between **Save Area** and **Save Area As** is the same as in the previous menus. If this is a new area you will be offered the option **Save Area As**. If this is an ex-

isting area which has its name, you will be offered both options **Save Area** or **Save Area As**. Internally the program will associate with each saved area its attributes.

15.5.5. Add Area to Map

With this command the area currently occupying the "area content" will be plotted onto the map with default attributes or attributes assigned by you using the **Edit Plot Parameters** option.

Before you add an area to a map check the attributes, especially whether the area will be transparent or not; also check screen and printer colors. If the area is not transparent you will cover the rest of the content of the map with the area. Likewise, if the background color (either screen or print) is any color other than white, the whole area will be painted masking thus the other content.



NOTE. The GWW software does not have an Undo command with which you may restore the previous screen.

15.5.6. Add to Legend

Building the legend block is context sensitive. You may add the currently active area to the legend. It will be shown as a rectangle, with all attributes as the area itself, that is the line thickness, line color, print color, and transparency or nontransparency. After you select **Add to Legend** you will be prompted for a text which defines the area.

15.5.7. Edit Plot Parameters

An area has its own attributes, or parameters. When you select this option, the screen will display a dialogue box such as shown in Figure 15-44. The double

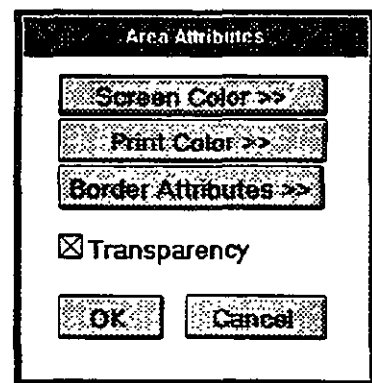

Figure 15-44

arrows to the right indicate that each of options extends into more options. Notice the box labeled **Transparency**. If crossed, the area will be transparent and the content under it will be visible. Options **Screen Color** and **Print Color** will open a color palette for you to select colors that will fill the area.

Option **Border Attributes** lets you define line thickness (from 1 through 6), line pattern (solid, dashed, dotted, dash dot, etc.), label which will intersect the border of the area and display or print a text, font for the label, distance where the label will be displayed or printed, and the spacing between two subsequent labels. An area border attributes dialogue box is displayed in Figure 15-45.

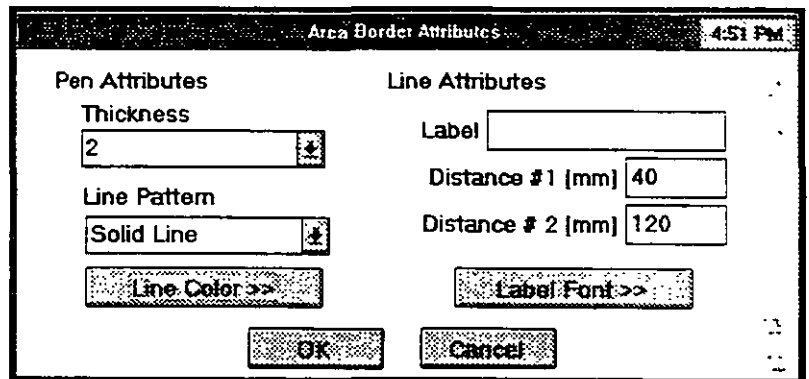

Figure 15-45

15.5.8. Standard ASCII Input and Output

You may save the currently active area in an ASCII file. The file contains only the coordinates of points making the area. One area is terminated with the combination /*

typed after the last point's coordinates. One example of an ASCII file containing two areas is reproduced partly below. Notice that the last point's coordinates are exactly the same as the first point's coordinates.

```
9236.12, 5842.62
9208.25, 5871.94
9168.44, 5853.06
9138.56, 5880.31
9142.56, 5911.75
.....
9341.69, 5846.81
9236.12, 5842.62
/*
9283.94, 5540.94
9307.81, 5584.94
9343.69, 5587.00
.....
9136.56, 5427.75
9108.69, 5455.00
9174.44, 5538.81
9283.94, 5540.94
/*
```

You may create such a file using any other commercially available software or a text processor. You may then input such file into the GWW data base using the option **Standard ASCII Input**.

15.5.9. DXF Output You may create a DXF output file with random points to use in another software package, most likely in AutoCad or another Computer Aided Design package. You will be prompted to select a file name and directory to save the output.

15.6.

LINE MENU

You will use this menu to add various lines to your map. These lines serve only to enhance a map, to add important line features, etc. The lines are not used for contouring, adding colors, and like procedures.

The Line menu contains the following commands or options, as shown in Figure 15-46:

- New Line
- Old Line
- Save Line
- Save Line As
- Add Line to Map
- Add to Legend
- Edit Plot Parameters
- Standard ASCII Input
- Standard ASCII Output
- DXF Output

New Line
Old Line
Save Line
Save Line As
Add Line to Map
Add to Legend
Edit Plot Parameters
Standard ASCII Input
Standard ASCII Output
DXF Output

Figure 15-46

- 15.6.1. New Line** The GWW mapping application in principle adds a new content of a kind to the content of the same kind that may eventually be filling the "content space." In the case of lines, this is interpreted as saying that there may be one or more lines already in the current "line content," and that any other line may just add to the content. To avoid mixing lines, you are advised to use the option **New Line**. Nothing visible will happen, but the command will remove from the current view any line that eventually may be there. With this command it is guaranteed that

you will work on a new line without any interference with an existing line.



To create a new line directly from GWW you must use its digitizing capability.

15.6.2. Old Line

The GWW data base and information system may contain one or more lines, which may be internally saved under specific names given to them by you in previous sessions. When you use this option the program displays a list of existing lines prompting you to select one from the list, as shown in Figure 15-47. When you select a line, it will be transferred into the "line content" with all of its attributes. The line attributes are: thickness, pattern, color, label, font for label, and text or label spacing.

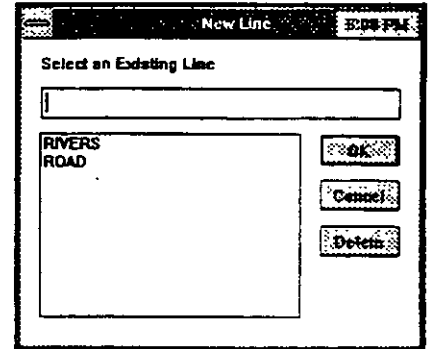

Figure 15-47

15.6.3. Save Line and Save Line As

Same as in other menus on the Mapping application title bar, these two commands are used to save a line under an internal name. If the line is a new untitled line you will be prompted to **Save Line As**, that is the program will display a list of existing line names from which you may choose one or assign an entirely name. The dialogue box with file name selection may look as shown in Figure 15-48. If you are working on an existing, or titled, line, you will have op-

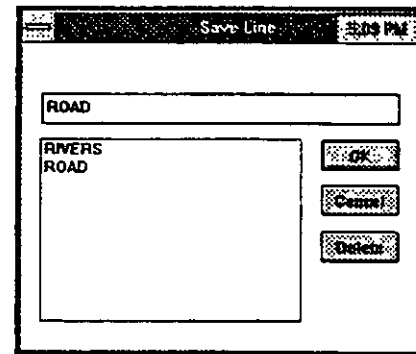

Figure 15-48

tion to **Save Line** under its own name, or **Save Line As** giving it another name.

15.6.4. Add Line to Map

You may add a line to the map. This is probably the reason why you are creating lines, editing them, giving them some attributes, and the like. You wish them added to a map. The line may be a river, a road, a wire fence, a boundary between geologic formations, or anything that is normally found on maps. Prior to adding a line to the map you should check line attributes or parameters; its thickness, pattern, color, etc. Once added, the line cannot be removed and the whole process of map building may have to be repeated.



NOTE. It is a good advice to save a map after several steps, so that you may start anew from a step before, not from scratch.

15.6.5. Add to Legend

The legend block is gradually built up of parts: some text, scale, contour lines from the **Grid** menu, random points from the **Random** menu, areas from the **Area** menu, various lines from the **Line** menu, etc. The option on the **Line** menu adds the currently available line to the legend. This means that if you wish to add more than one line to the legend block, you must place a line into the current "line content" and apply the command **Add to Legend**, then select a **New Line** and transfer another line using either **Old Line** or **Standard ASCII Input** command, and apply again the command **Add to Legend**. Each time you select **Add to Legend** you will be prompted to enter explanation text, such as shown in Figure 15-49.

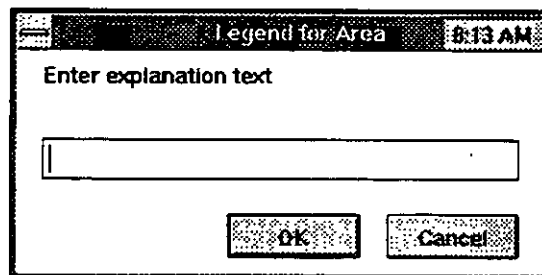

Figure 15-49

15.6.6. Edit Plot Parameters

This option works in the same way as in the Area menu. You may select the line thickness from 1 to 6, the line pattern (solid line, dashed, dots, and combinations), line color, the font for the label, and spacing between subsequent labels. The display is as shown in Figure 15-50.

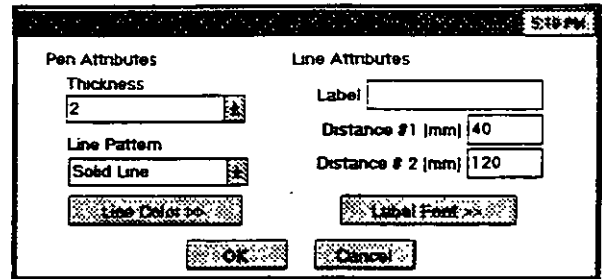

Figure 15-50

You may "outsmart" the program by digitizing a line, writing some label

or text which defines the line, and by selecting white color, or no color for the line. In this case the line will not be drawn but the text will. This is a handy possibility for writing some text next to an existing line, such as the Rio Vaca Vieja parallel to the river line as shown in Figure 15-51. The text was created following the steps:

1. Select **New Line**.
2. Digitize line (click on **Dig.Line** button to start digitizing).
3. Terminate digitizing (click on **End Point** followed by **End Digit**).
4. Select **Edit Plot Parameters**.
5. Select **Line color** and click on blank field in the right lower corner.

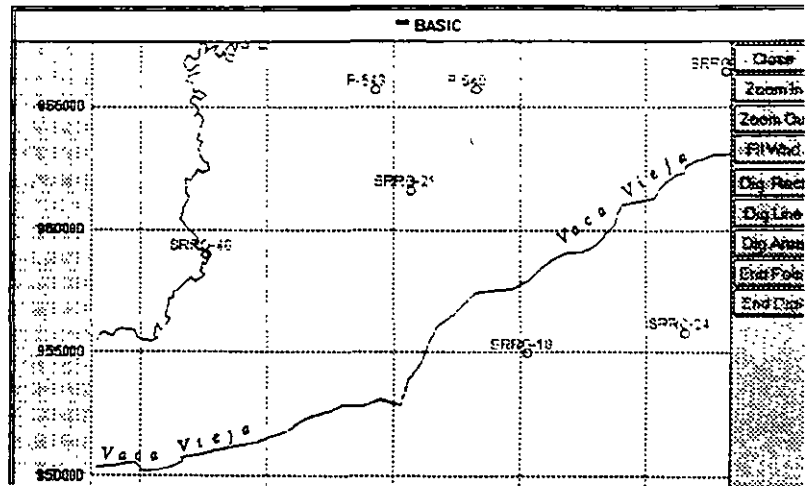

Figure 15-51

6. Write to label field "Vaca Vieja", change Distance #1 from 40 mm to 0 mm, change the second default number from 120 mm to 60 mm and select OK.
7. Select Palton font, 10 points, Italic. Click on OK to exit this option.
8. Select Add Line to Map.

What is created is an invisible line with text that is visible. We are sure that you will find this small trick quite useful. (You may have selected No Line from Line Pattern.)

15.6.7. Standard ASCII Input and/or Output

You may save the currently active line in an ASCII file. The file contains only the coordinates of points making the line. One line is terminated with the combination /* typed after the last point's coordinates. One example of an ASCII file containing two lines is reproduced partly below.

```
672367.68700000    969797.25000000
672282.68700000    969622.25000000
672537.68700000    969119.25000000
672610.68700000    969004.25000000
```

672987.68700000	969432.25000000
.....	
666385.75000000	938400.43700000
666450.75000000	938195.43700000
/*	
635542.68700000	969912.25000000
635772.68700000	969609.25000000
635532.68700000	969449.25000000
635469.68700000	969092.25000000
635309.68700000	968944.25000000
635234.68700000	968937.25000000
635339.68700000	968734.25000000
635474.68700000	968587.25000000
635464.68700000	968349.25000000
....	
628327.68700000	955647.25000000
628292.68700000	955439.25000000
/*	

You may also import one or more lines from an ASCII file. The input format is free; the X and Y coordinates must be separated by one or more spaces or a comma. One pair of coordinates, that is one point of a line, is typed on one line of the ASCII file.

The program will prompt you to select a file name for the line either when you wish to read the line from an ASCII input file, Figure 15-52, or when you want to write to an ASCII file, Figure 15-53.

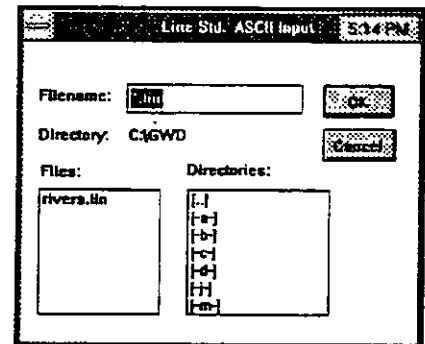

Figure 15-52

15.6.8. DXF Output

You may create a .DXF output file to use in another software package, most likely AutoCad or another Computer Aided Design package. You will be prompted to select a file name and directory to save the output. The program will open

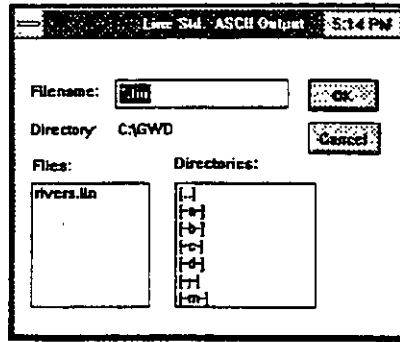

Figure 15-53

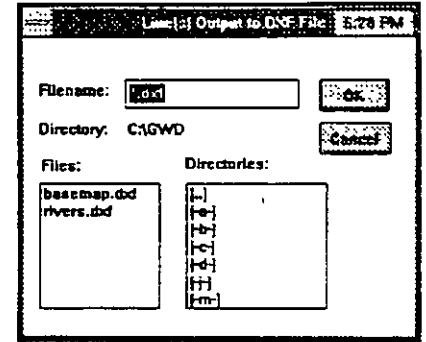

Figure 15-54

a dialogue box with the list of available files with the extension .DXF, as shown in Figure 15-54. You will be prompted to select a file name.

15.7. TEXT MENU

You will use this menu to add text lines to your map. You may add a heading or a title to your map, write some comments, etc. You do not need to use the text menu options to create a legend. It is done using options from all mapping menus.

The Text menu contains the following commands or options, as shown in Figure 15-55:

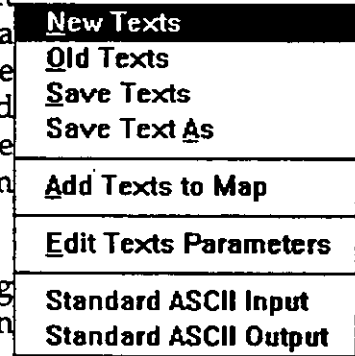

Figure 15-55

- New Text

- Old Text
- Save Text
- Save Text As
- Add Text to Map
- Edit Text Parameters
- Standard ASCII Input
- Standard ASCII Output

15.7.1. New Text Use this option to create a text block. Each set of text information is called a block. For each line of text you will specify the coordinates of the beginning of the text string or the position of the text block, the angle of the text block, color of the text, the fonts, and the horizontal and vertical alignment.

When you select the **New Text** option, the dialogue box as shown in Figure 15-56 will be displayed. The only reasonable option available for a new text is the button

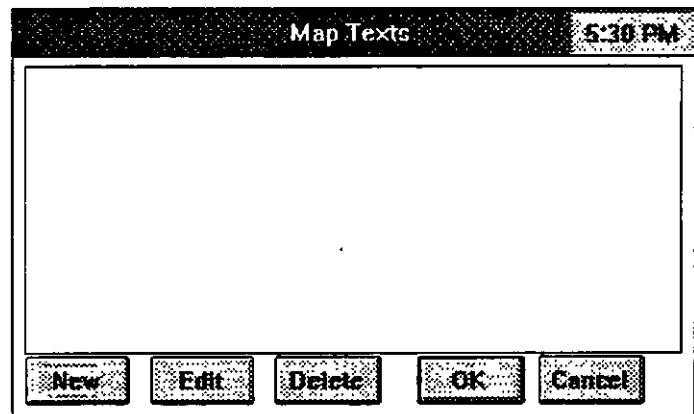

Figure 15-56

- New. Click on New. The screen will display the Text Attributes dialogue box as shown in Figure 15-57. Placement of text is determined by the X and Y coordinates of

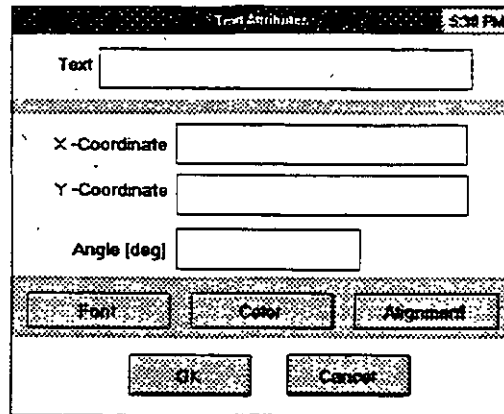

Figure 15-57

the lower left corner of the first letter of the text string, or by alignment attributes in the Text Attributes dialogue box.

You may write more than one line of text, assigning to each its position, angle, fonts and colors.

You may save this text block under its own internal file name. You may have many such text blocks or file names.

15.7.2. Old Text

You will use this option to retrieve a previously created and saved text file containing one or more lines of text information. When you use this option the program displays a list

of existing texts prompting you to select one from the list, as shown in Figure 15-58. When you select a text, it

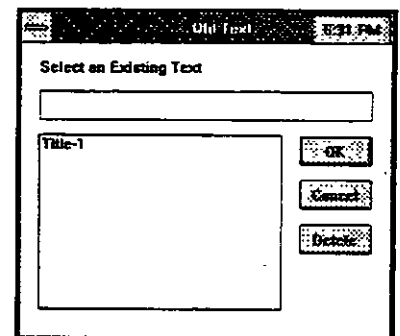

Figure 15-58

will be transferred into the "text content" with all its attributes.

- 15.7.3. Save Text and Save Text As** Same as in other menus on the Mapping application title bar, these two commands are used to save a text under an internal name. If the text is a new untitled text you will be prompted to **Save Text As**, that is the program will display a list of existing text names from which you may choose one or assign an entirely new name. The dialogue box with file name selection may look as shown in Figure 15-59. If you are working on an existing, or titled, text, you will have option to **Save Text** under its own name, or **Save Text As** giving it another name.

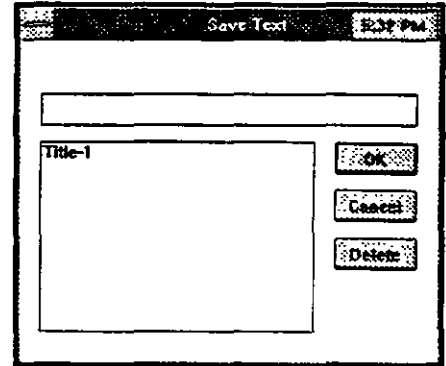

Figure 15-59

- 15.7.4. Add Text to Map** You may add a text to the map. This is probably the reason why you are creating texts, editing them, giving them some attributes, and the like. You wish to add them to a map. The text may be a header, a subtitle, a company name, a comment or description, or anything that describes or enhances a map. Prior to adding a text to the map you should check text attributes or parameters, that is its position, angle, font family and size, and color. Once added, the text cannot be removed and the whole process of map building may have to be repeated.

One example of adding text is shown in Figure 15-60. This is an insert, zoomed in.



NOTE. It is a good advice to save a map after several steps, so that you may start anew from a step before, not from scratch.

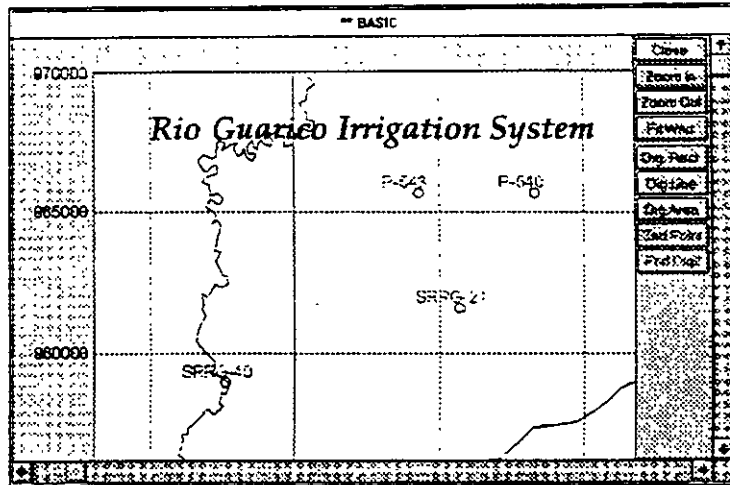

Figure 15-60

15.7.5. Edit Text Parameters

When you select this option, the dialogue box such as the one shown in Figure 15-61 will be displayed. Using this option you may:

- Edit an existing text string.
- Add another text string to the same text block.
- Delete one or more text strings.

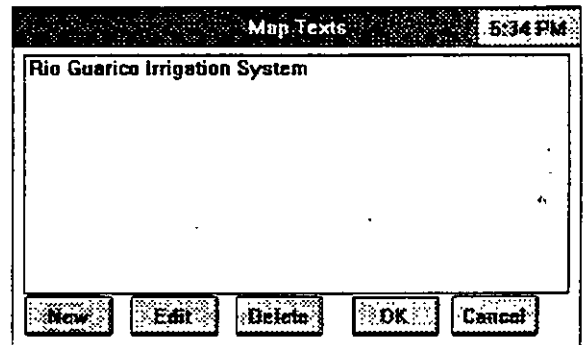

Figure 15-61

Editing a text string or text line means changing the text itself, moving its position by changing X or Y coordi-

nates, replacing one font family and size with another, or changing its color.

To edit you should do the following:

1. Select with the cursor the line of text you wish to edit. This line will be highlighted.
2. Click on **Edit** button. GWW will open another dialogue box, **Text Attributes**, as shown in Figure 15-62.

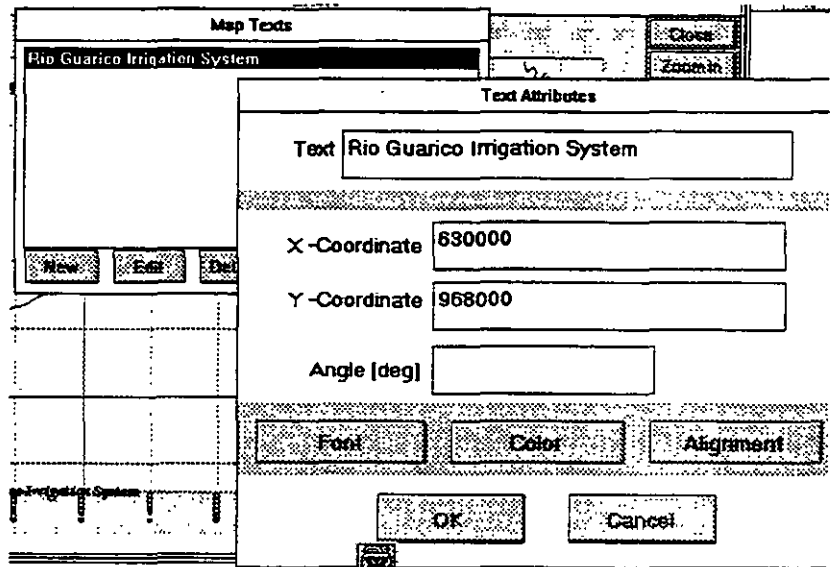

Figure 15-62

3. Work on modification and select **OK** to return to the text menu.

To create a new line of text within the same text block you should do the following:

1. Click on **New** button. GWW will open an empty dialogue box, **Text Attributes**, such as shown in Figure 15-57.
2. Create the new line of text by filling all boxes. Select **OK** to return to the text menu.
3. Remember to save this modified text block using either **Save** command, or **Save As**.

To delete a line of text from the current text block you should do the following:

1. Select with the cursor the line of text you wish to delete. This line will be highlighted.
2. Click on Delete button. This line of text will be deleted.
3. Remember to save this modified text block using either Save command or Save As.

15.7.6. Standard ASCII Input

You may save a text that was created in GWW in an ASCII file, or you may create a text file with a text editor. When you wish to input the text as an ASCII file, GWW will prompt you for a file name to select the text, as shown in Figure 15-63.

To use a text editor you must observe certain rules and conventions. The text displayed in the example above when stored as an ASCII file will contain the following:

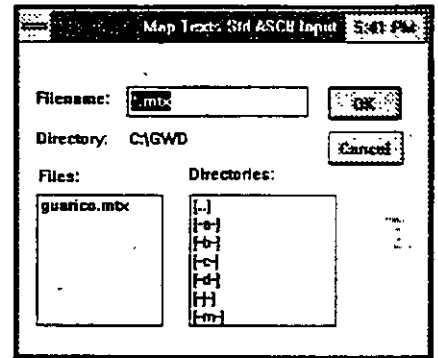

Figure 15-63

```
"Rio Guarico Irrigation System" 632000 968000
10 0 17 49 0 "Palton" 0 0 0 1 1 0
```

Evidently, the first line is the text limited with quotation marks, followed by the X and Y coordinates defining its position on the map. The second line contains the text string attributes and font family, size, and color. The font family is Palton. The three 0 after the word Palton are color codes, meaning red, green, blue are each set at 0 value. The combination of three "zeros" is the black color. Remember that color values are from 0 to 255. The combination 255,0,0 is interpreted as pure red, the combination 0,255,0 as pure green, and the combination 0,0,255

as pure blue. Each other combination of numbers is another nuance. (This is to say that there will be over 16 million colors. Multiply 256 by 256 by 256 to see how many colors you may create!)

The set of numbers after the color code, that is 1 1 0 defines text font attributes, that is normal or bold, normal or italic, normal or underlined. 0 is for normal, 1 is for bold, italic, and underlined, in this order.

The first three numbers in this line define the horizontal and vertical offset of the text beginning, and the alignment of the text string. You should not be concerned with this, although you may know that the number 10 means horizontal offset (from the X,Y coordinates) equal to 10 tenths of a millimeter, or, in this case, 1 mm. The number 0 which follows implies 0 tenths of millimeter vertical offset. The number 17 is a combination uniquely defining the horizontal and vertical alignment. The remaining two numbers, 49 and 0, define the size of the font selected in 1/10th of a millimeter and the angle in degrees. The size of 49 is equivalent to 4.9 mm, or to 14 points. The size of 56 is equivalent to 16 points, 64 is equivalent to 18 points, and 21 to 6 points.

Using the text editor to modify an existing text string or to create a new one becomes handy when you wish to create text strings longer than the maximum length assigned by GWW.

An ASCII text file with two lines of text may look as reproduced below.

```
"Rio Guarico Irrigation System" 632000 968000
10 5 17 49 0 "Palton" 0 143 255 1 1 0
"Estado Guarico, Republic of Venezuela" 632000 965000
10 0 17 42 0 "Arial" 0 0 0 0 0 0
```

When this file is imported into GWW and the command **Add Text to Map** is applied, the displayed text may look as shown in Figure 15-64.

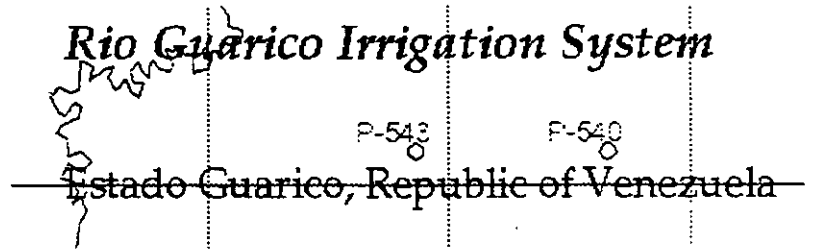

Figure 15-64

15.7.7. Standard ASCII Output

You may save a text file, with one or more lines of text, that was created in GWW as an ASCII output file. You may then edit this file using your text editor and import it again into GWW as an input ASCII file. Before you export the file, GWW will prompt you to give a file name to the text as displayed in Figure 15-65.

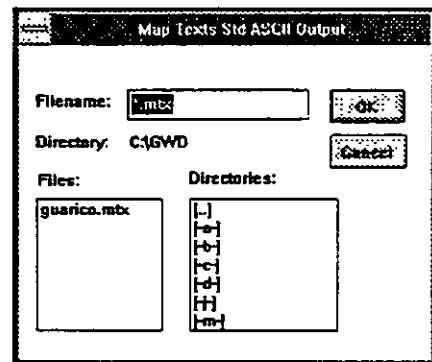

Figure 15-65

This page intentionally left blank.

16.1 INTRODUCTION

This is a utility option in GWW which makes possible individual customization of various screen displays and printouts.

It has been stated earlier that GWW is language-independent, or almost so! Under "language-independent" we mean that you do not need to have English captions, titles, headers, etc. on your screen display and/or in printouts. You cannot replace English messages, menus, comments, instructions, and the like. But you may create reports of every part of the package in your own language. This is made possible by using options from this Customization package.

When you select Customization from the main menu bar the screen displays the list of applications in which you may change either display or print attributes or replace English words with a "foreign" word. The display is as shown in Figure 16-1. Out of thirteen major application modules, Master Data, Cross Section, Fence Diagrams, User applications, and Mapping applications do not

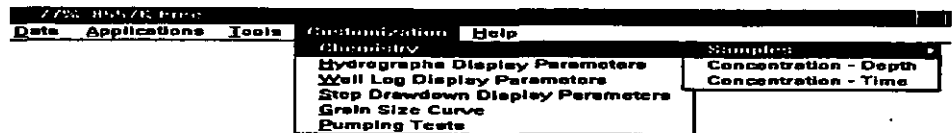

Figure 16-1

need modifications. In these applications you create the display and printouts yourself. There is nothing pre-designed or default there. Every other major application can be customized or default settings modified by you.

The applications that can be customized are the following:

- Chemistry
- Concentration-Depth
- Concentration-Time
- Hydrographs
- Lithology (well logs)
- Step Drawdowns
- Pumping tests, and
- Grain Size Curves

Remember that changes made in the Customization option will be written to the file GWW.INI which will be located in the Windows directory, just like any other "Application".ini file. Some portions of this file are reproduced below.

```
[GWW]
GWWDataBase=c:\gwd\test2.gww
LastPumpTests=PT-1
LastIdent=PO-1
Frame=100 10 1800 2500
LastMasterData=P-540
....
LastLithology=PO-1

[PumpTests]
QUnit=m3/day
LengthUnit=m
....
TimeUnit=min

[WellFunct]
....
TransUnit=gpd/ft
....
DrawUnit=feet
```

```
[Stiff]
StiffBorderDisp=255 255 255
StiffBackgroundDisp=255 255 255
StiffLinesDisp=0 0 0
StiffInteriorDisp=0 0 255
StiffLabFontDisp='Arial' 12 0 0 0 0 0
StiffSymFontDisp='Arial' 10 0 0 0 0 0
```

16.2. CHEMISTRY APPLICATION

In the Chemistry application, as shown in Figure 16-2, you may customize the display and print for each of the

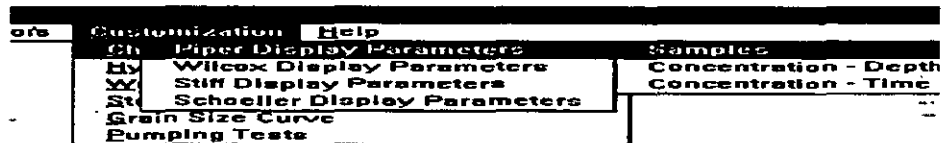

Figure 16-2

chemical data graphical presentations: Piper, Wilcox, Stiff, or Schoeller diagrams. Since each of the presentations has a graphical drawing and a textual content, the options on the customization menu refer to screen and print colors (for border, background, or coordinate lines, or lines connecting points), to font family and font size for any textual content, to symbols appearing on screen displays or printouts.

The options for the chemistry application are shown in the following Figures: 16-3 and 16-4 (Piper), 16-6 (Wilcox), 16-7 (Stiff), and 16-8 (Schoeller). The change of text is illustrated with the example in Figure 16-5. The word 'CATIONS' you may replace with the word 'CATIONES'

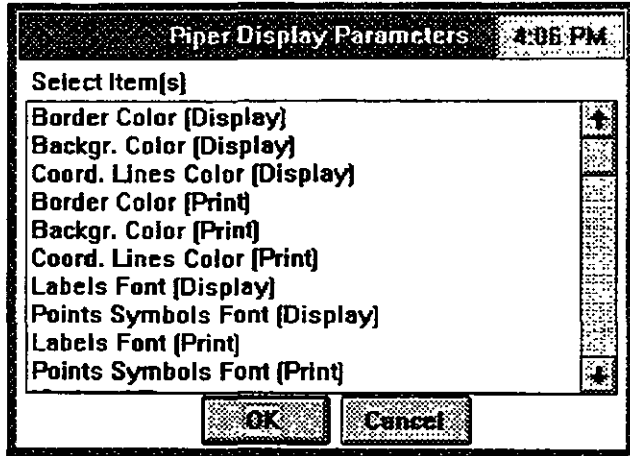

Figure 16-3

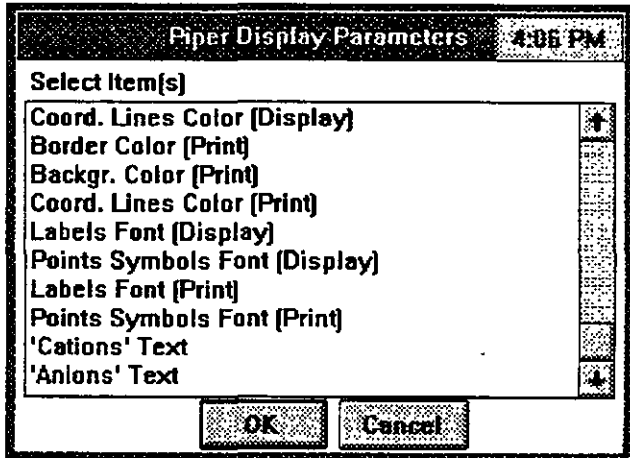

Figure 16-4

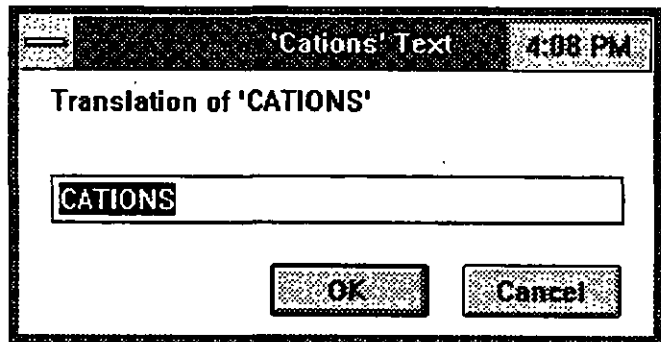

Figure 16-5

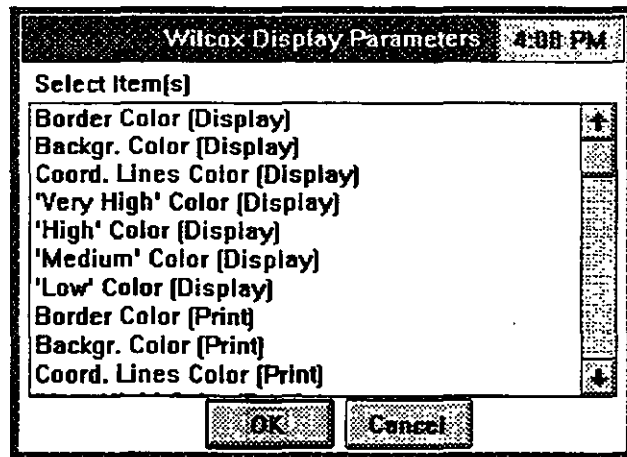

Figure 16-6

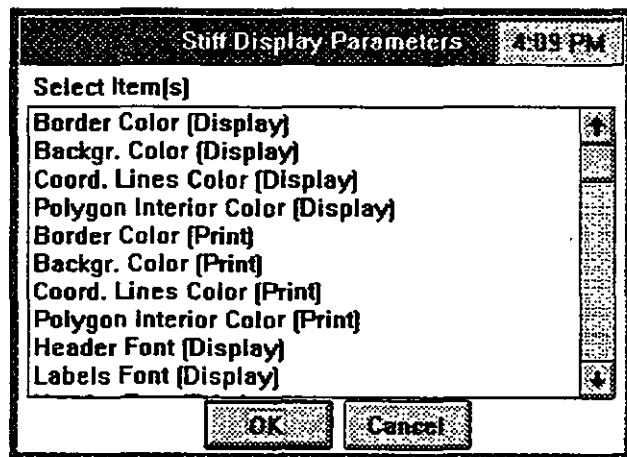

Figure 16-7

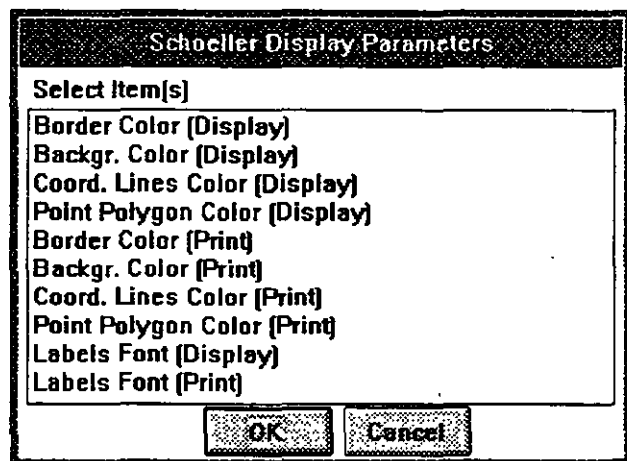

Figure 16-8

if you wish to write in Spanish, or 'KATIJONI' if you wish to use Serbian language.

16.3. HYDROGRAPHS APPLICATION

Only the lower portion of all options available for this application is shown in Figure 16-9. If, for example, you

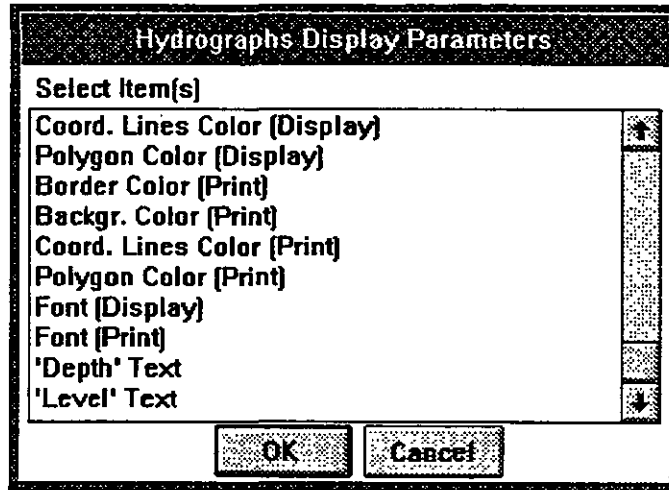

Figure 16-9

wish to report in Spanish, you will replace the word 'Depth' with its Spanish equivalent 'Profundidad,' as it is shown

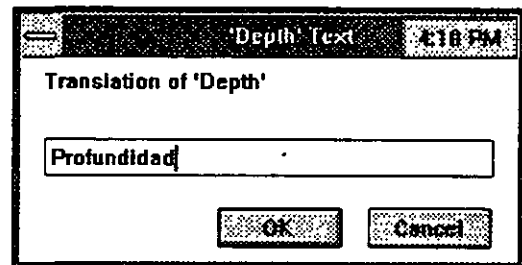

Figure 16-10

in Figure 16-10, or the word 'Level' with 'Nivel,' etc. You may also customize colors, fonts, color of textual attributes, etc.

16.4. WELL LOGS

You may enhance your lithologic or well log by selecting different colors, and fonts. You may replace the header

which contains the words 'Depth,' 'Hole,' 'Annulus,' 'Casing,' 'Screen,' and 'Lithology,' with other words or equivalents in other languages. If you select fonts such as Czar from CorelDraw or Cyrillic from other sources, you may create a well log in Russian using Cyrillic alphabet. (Of course, you may do it in Arabic, Hebrew, or any other language, provided you have fonts for their alphabets available.)

Well log display and print parameters, available for customization, are displayed in Figures 16-11 and 16-12.

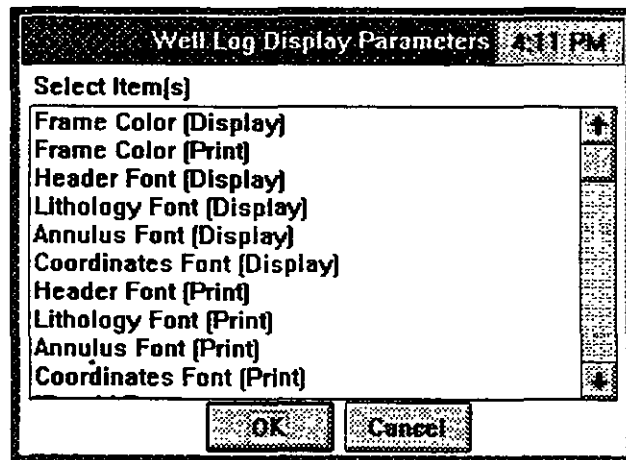

Figure 16-11

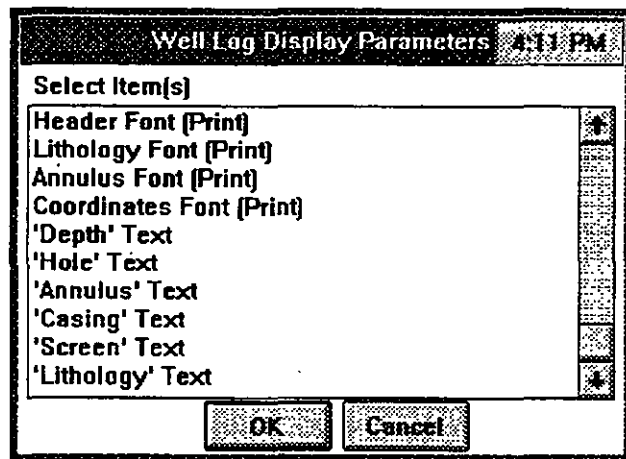

Figure 16-12

16.5.

**STEP DRAWDOWN
APPLICATION**

In a step drawdown diagram the following text appears on the graph or in the table: 'Drawdown,' 'Pumping Rate,' 'Aquifer Loss,' 'Well Loss,' and 'Efficiency.' You may replace each of these with their equivalents. The options are shown in Figure 16-13.

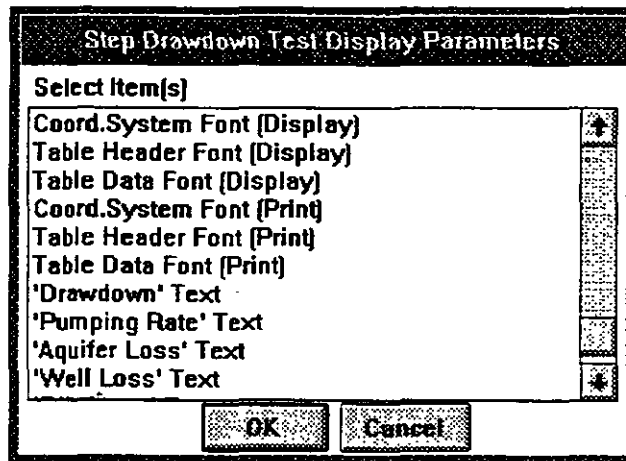

Figure 16-13

16.6. **GRAIN SIZE
CURVE
APPLICATION**

Here again, every word that appears on the diagram may be replaced. This is shown in Figure 16-14. In addition you may control the color of display and of print-outs. You may "paint" the background, frame, or border of the drawing to enhance it if you are going to print in colors.

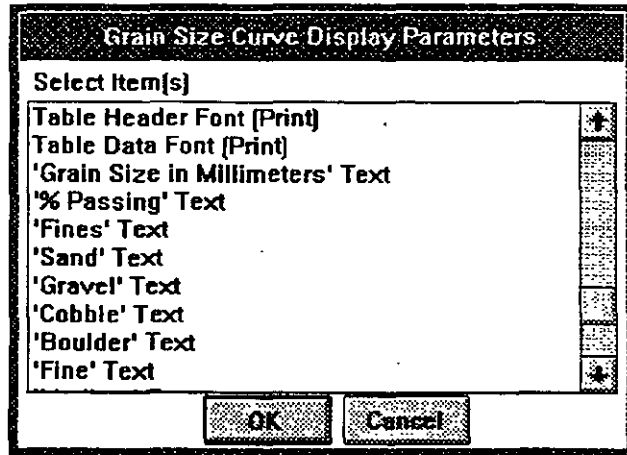

Figure 16-14

16.7. PUMPING TEST APPLICATION

Almost everything that is presented either on screen or printed can be customized. One portion of options is displayed in Figure 16-15. This is mostly the textual part of the pumping test display, but you may also control colors of lines, coordinates system, data points, background, and the like.

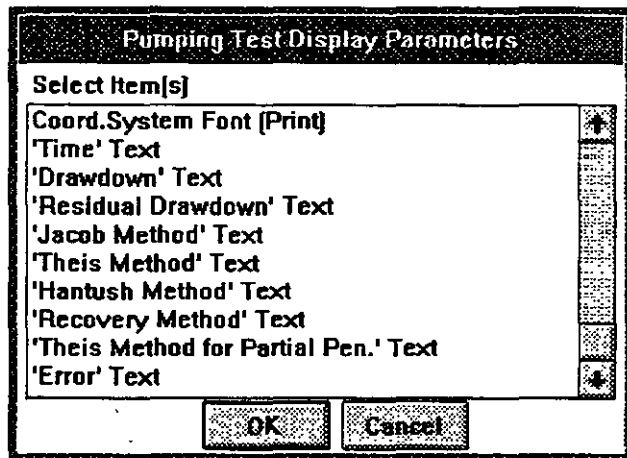

Figure 16-15

16.8.
CONCENTRATION -
DEPTH SERIES

In this applications, most of customization is done from the application's menu. There, you can select header fonts, axis labeling, coloring and filling with colors various parts of a diagram. Here, you may replace one of the two English words, as shown in Figure 16-16.

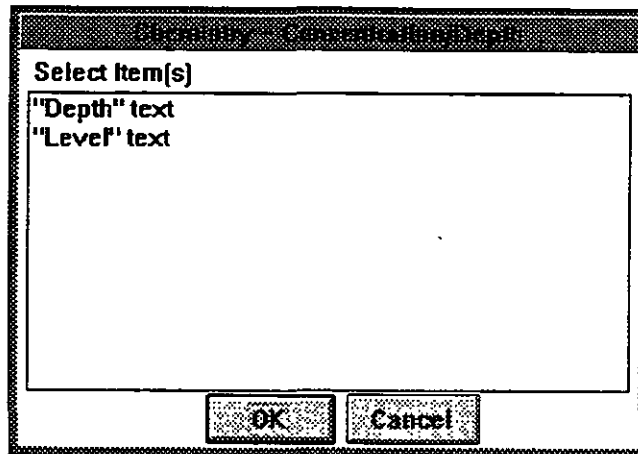

Figure 16-16

16.9.
CONCENTRATION -
TIME SERIES

Although you may modify the display or print-out to some extent directly from the application, most of the customization will be done from this menu.

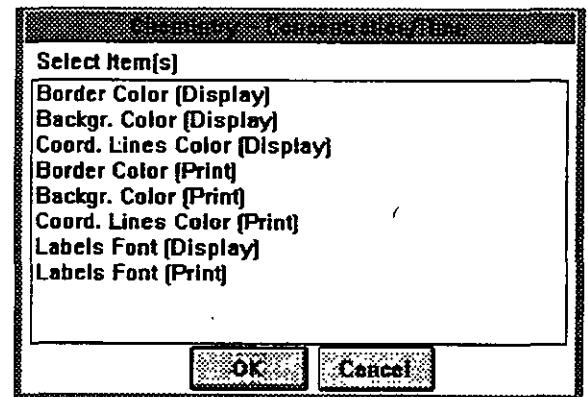

Figure 16-17

17.1 INTRODUCTION**17.1.1. General**

Using this application you may create fence diagrams, displaying on the screen and in reporting forms the following:

- Lithology at borehole sites.
- Hydrogeologic information such as water table.
- Stratigraphic information by connecting layers with different lines.

You may add lines created from gridded models in the Mapping application. You may also use free-hand drawing of lines, close polygons and fill in with lithologic or other symbols.

Since it is a three dimensional presentation of the lithology of a terrain on a two dimensional screen and paper, you may control angles of rotation along the x and y axis, and angle of projection on the Z axis.

As in the other general-purpose utilities within GWW, such as Mapping and Cross Section, you may select horizontal and vertical scales to fit your drawing on a selected paper format.

GWW stores fence diagrams as a part of the information system. The last created fence diagram is displayed almost automatically when you select this application. Thus the lithology of a selected part of the area is immediately visible.

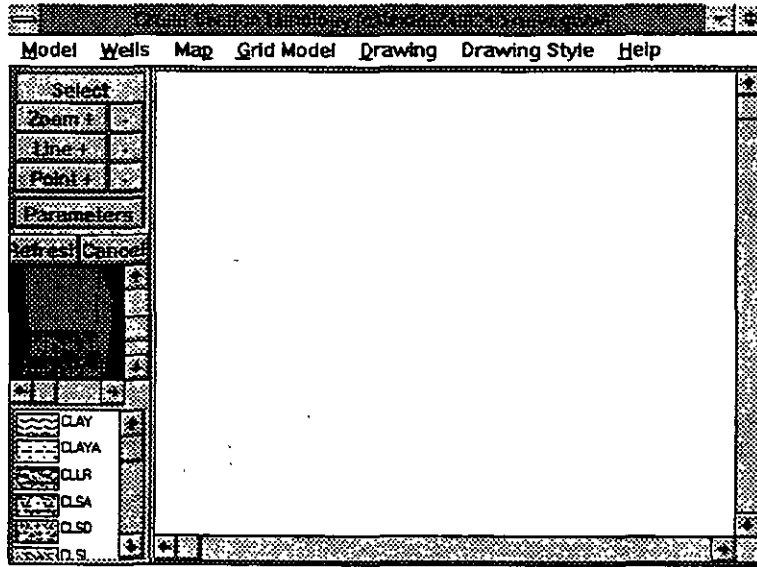

Figure 17-1

17.1.2. Application's Content As shown in Figure 17-1, the Fence Diagram application is comprised of the following major options:

- Model
- Wells
- Map
- Grid
- Drawing
- Drawing Style
- Help

The Model menu is shown in Figure 17-2. In this menu you control the content of the fence diagram, the viewing angles, the scales, and the general layout of the drawing.

The Wells menu is shown in Figure 17-3. In this

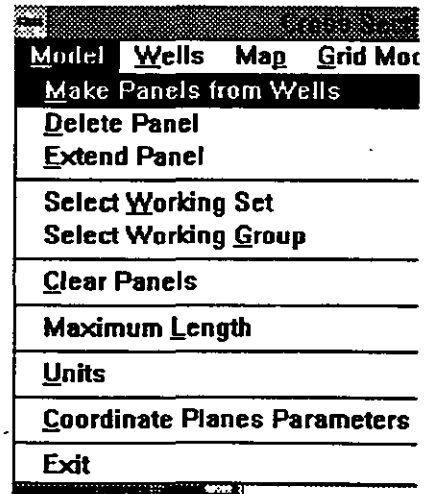

Figure 17-2

menu you select wells to be used in a fence diagram. Before using the Model menu you will normally start by selecting wells to represent lithology.

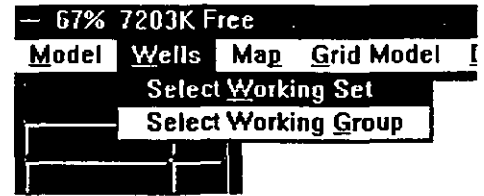

Figure 17-3

The Map menu is shown in Figure 17-4. This is a shortcut for selecting wells. You may create a working set or working group of wells directly from a map.

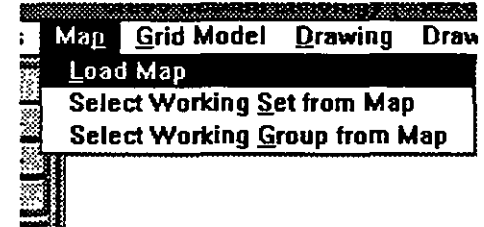

Figure 17-4

The Grid menu is shown in Figure 17-5. Using this menu you may add one or more lines to the fence diagram. These lines are created in the Mapping application.

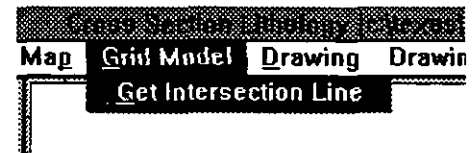

Figure 17-5

The Drawing menu is shown in Figure 17-6. With this menu you will finish the fence diagram as a drawing. You will add various legend blocks, such as the one explaining lithologic symbols used in the diagram, various

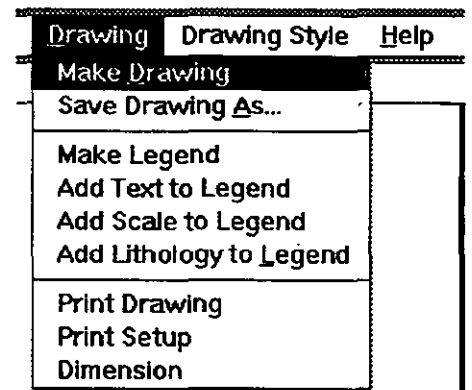

Figure 17-6

headers and textual explanations.

The Draw Style menu is shown in Figure 17-7. Using this menu you will control several display options, e.g. the width of lithologic columns.

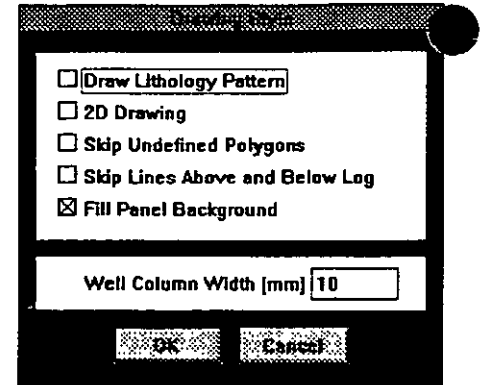

Figure 17-7

17.2. MODEL MENU

The three dimensional presentation of lithology of an area is actually modeling the lithology of an area. You select which part of the area you wish to model, which wells to use, how to present them; and you change the angles of viewing the cross section.

The Model menu serves to create "panels" which put together make a fence diagram or a lithologic model of the area.

A panel is a rectangle in space drawn in such a way that a pair of two neighboring wells makes panel sides. One of the panels is shown in Figure 17-8. A well which is

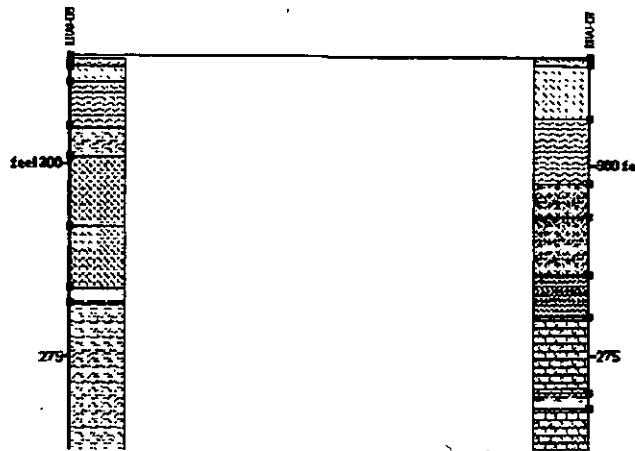

Figure 17-8

used by two or more panels is shared by these panels (Figure 17-9). More than one panel can be drawn through one well. Each panel may contain only two wells.

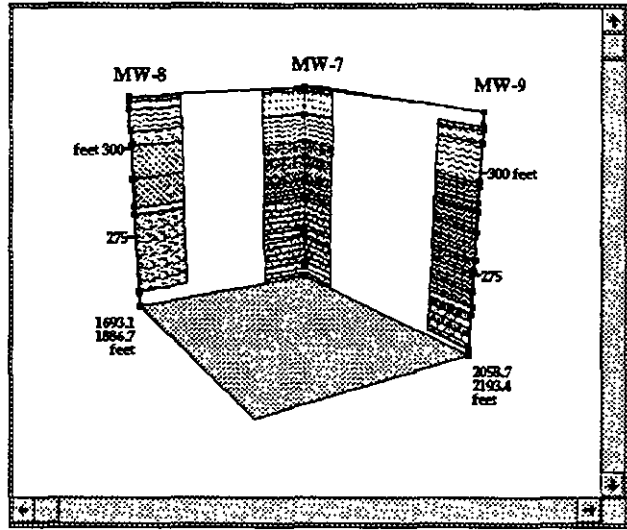

Figure 17-9

Panels are labeled using the names of wells that make a panel. As shown in Figure 17-10 the labeling is (MW-7 - MW-9). Panels can only join one with the other but they cannot cut through or protrude through.

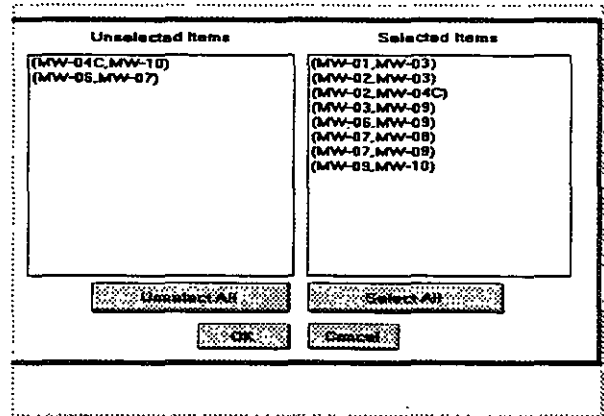

Figure 17-10

17.2.1. Make Panels from Wells

When this option is selected GWW automatically creates panels from wells making the working group. Panels which would cut through another panel will not be created. This is to say that in some cases you should not expect that all possible combinations of panels will be created. For example, with 3 wells labeled W-1, W-2, W-3, it may or may not happen that there will be three panels. If one of the panels is in the way of another panel, it will be eliminated.

The effect of this command is immediately evident. A fence diagram will be displayed on the screen using current scales,

orientation s, fonts and color attributes. A typical screen may look as shown in Figure 17-11. Notice that some wells are shared by three panels.

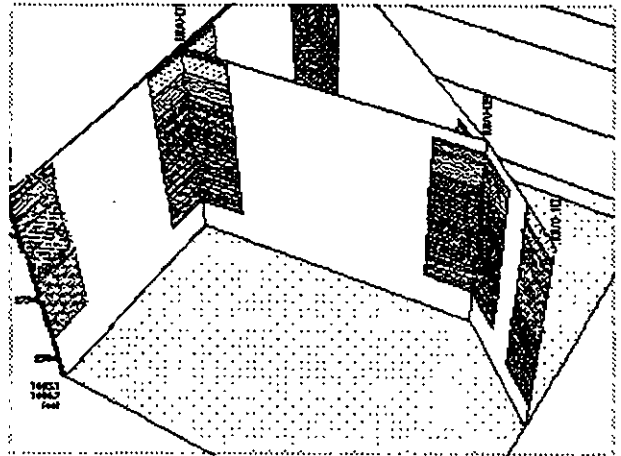

Figure 17-11

17.2.2. Delete Panel

Once created, panels are stored in the information system created by GWW with all their attributes and additional contents. Panels are like building blocks making the final drawing. Each panel is like a cross section connecting two wells. You may delete one or more panels from the information system. When this command is selected the screen displays a dialogue box as shown in Figure 17-12.

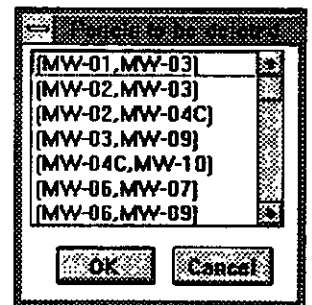

Figure 17-12

All available panels are listed. You may click on one or more panels to select (highlight) them to be deleted. When you click on OK they will be deleted.

17.2.3. Extend Panels

In this application panels are defined as rectangles enclosing a space between two neighboring wells. However, there may be cases when you will want to create a panel which will have only one side coinciding with a well while the second side will be free. Such panels may be needed when you wish to interpret and display lithology beyond end wells in a cross section. Such panels are created by "extending" an existing panel using the command Extend Panel. The dialogue box as shown in Figure 17-13 will be displayed with the list of all available

Figure 17-13

panels. Extending a panel you will not widen this panel but you will create a new panel which will share the side well and will have the length as entered by you in the right side of the dialogue box. The newly created panel becomes independent and behaves in the same way as other panels.

17.2.4. Select Working Set (of Panels)

The command Select Working Set on the Model menu implies the selection of panels that make a current working set. You may have many wells making a current working group of wells, and you may have created

many panels from the group of wells [using the command Make Panels from Wells]. Using this command you may eliminate some of panels that you do not want to work with. When this command is selected the dialogue box as shown in Figure 17-14 is displayed. Clicking with the mouse on a panel name on either Selected

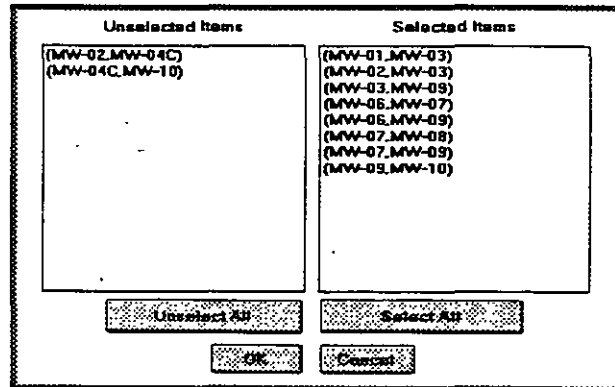

Figure 17-14

or Unselected side you will move the panel to the other side.

17.2.5. Select Working Group (of Panels)

The command Select Working Group on the Model menu implies the selection of panels that will make a current working group. These will be the panels used to create a fence diagram after you click on the Refresh button. When this command is selected the dialogue box as shown in Figure 17-15 is displayed. Clicking with the mouse on a panel name on either Selected or Unselected side you will move the panel to the other side.

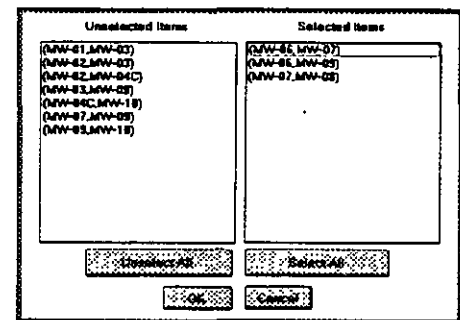

Figure 17-15

17.2.6. Clear Panels This command is used to remove additional "enhancements" to a panel. For example, you may add lines either hand drawn or from the Mapping application. Also you may fill in a layer with a lithologic pattern. A panel may look as shown in Figure 17-16. Using the command Clear

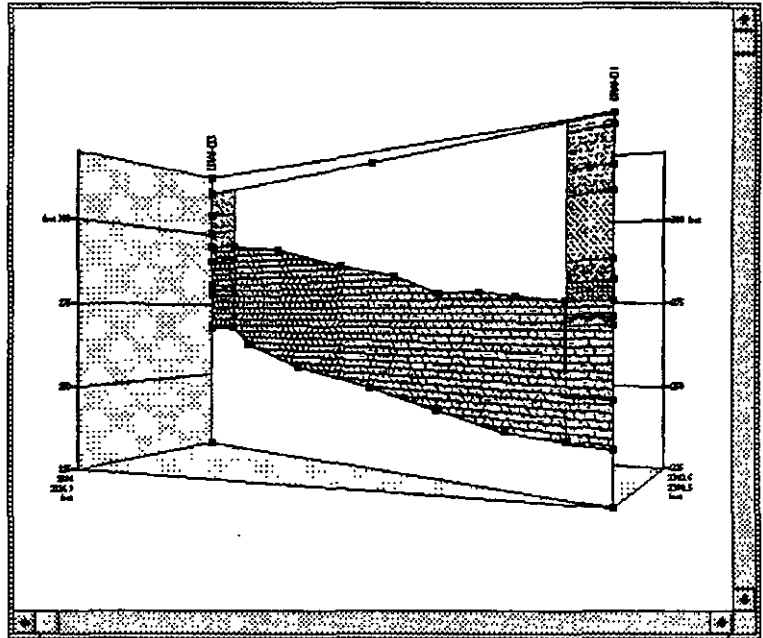

Figure 17-16

Panels all content other than lithologic columns will be eliminated and the screen display may look as shown in Figure 17-17. Using this command all panels currently displayed will be cleared.

17.2.7. Maximum Length

Panels are automatically created using X and Y coordinates of wells. Some panels may be too long. You may reduce the length of each panel by assigning a maximum allowed length. The dialogue box is as shown in Figure 17-18.

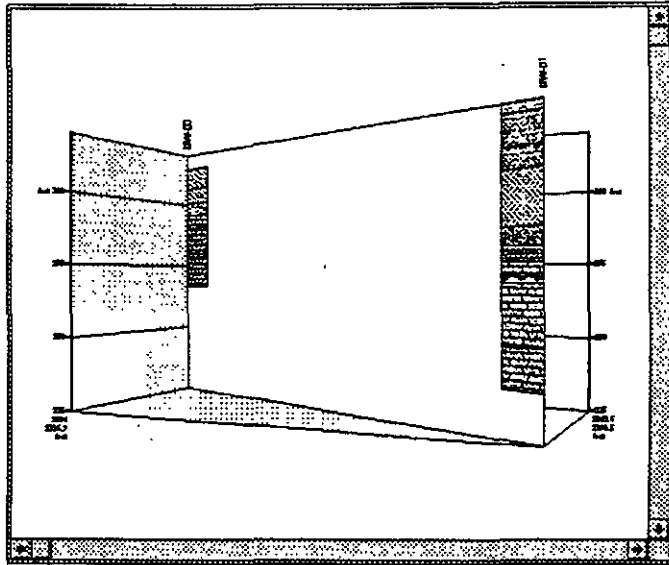

Figure 17-17

17.2.8. Units The units are taken from the Cross Section application. However, you may change units within this application.

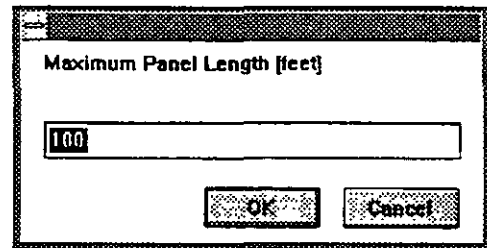

Figure 17-18

When you select the Units command you will be offered a dialogue box for Coordinates and for Elevations.

17.2.9. Coordinate Plane Parameters

When this command is selected, the dialogue box as shown in Figure 17-19 will be displayed. It is composed of four parts: Coordinates, Scales, Z Label Font and Colors for coordinate planes. When the Make Panels from Wells command is invoked GWW will scan all wells and will display the range of X, Y, and Z values for all wells making a current working group. You may change this

Coordinate Plane Drawing Parameters

Coordinates		
	From	To
X	2183.95	2342.63
Y	2316.86	2390.52
Z	225	320.4

Scales

Horizontal 1 :

Vertical 1 :

Colors

X-Y plane

X-Z plane

Y-Z plane

Z Label Font

Z Label Distance feet

Figure 17-19

manually in this dialogue box. Normally you may want to increase the top elevation (Zmax) to enhance the topography. Or you may want to eliminate some deeper layers by increasing Zmin and emphasizing only the upper part of a fence diagram.

Selecting scales is not that straight forward procedure as it was in the Mapping or Cross Section applications. Remember that this is a "quasi" three dimensional presentation on a two dimensional plane (screen or paper). The final dimension of a drawing will depend on several factors: on horizontal and, to lesser extent, vertical scales, on angle of rotation around X axis (to be selected under the Parameters button) and on angle of rotation around Z axis.

The best practice is to select different combinations and check the size of the drawing using the option Dimension on the Drawing menu.

The Z label font part of this dialogue box is intuitive. So is the Color part in which you will select background colors for "vertical" walls and the "horizontal" base of a fence diagram. (Neither the walls are vertical nor the base is horizontal, in most cases.)

17.2.10. Viewing Parameters

With the button Parameters you may control the following:

- Rotation angle around the Z axis.
- Rotation angle around the X axis.
- Relative projection distance.
- Normal or central projection.

The angles of rotation enhance or hide some portions of a fence diagram. The best practice is to experiment with different angles and find a combination which displays best what one wants to present.

The relative projection distance is a measure of the viewer's location. It is equivalent to the diagonal of the three dimensional space that is displayed; and measured from the center of the space. It cannot be less than 1, that is a viewer is not allowed to "enter" too close into the model.

The dialogue box with parameters is as shown in Figure 17-20. Figures 17-21 and 17-22 show the difference between an orthogonal and a normal projection, respectively. The angles of rotation around the Z and X axes are 30 and 45 degrees, respectively in both cases.

The angles of viewing can be assigned in a more convenient way by sliding scroll bars in the middle part of the left-side window. Sliding the bars in whichever way you will rotate the coordinate triedar. When you wish to display the new view click on the Refresh button. If you have rotated the triedar, but have decided not to change the viewing angles, press the button Cancel.

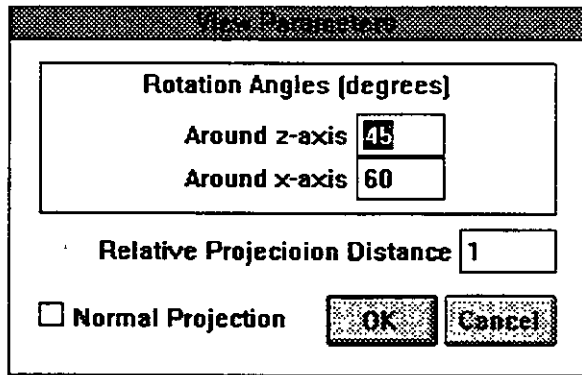

Figure 17-20

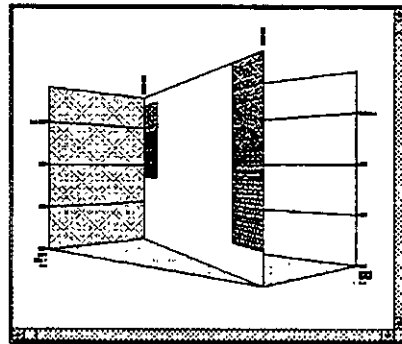

Figure 17-21

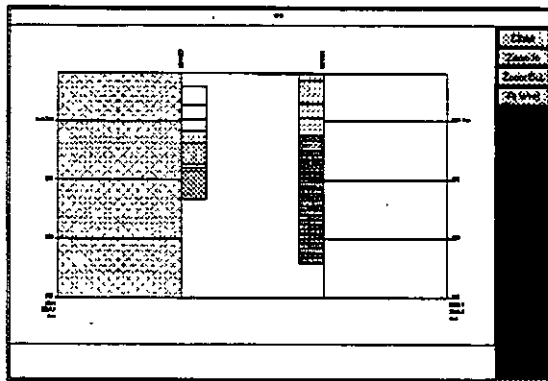

Figure 17-22

17.2.11. Hand Drawn Lines

A free hand drawing is an option in this application. However, you should work in panels. Each panel is an independent entity. You cannot extend a line from a

panel to another in a straight forward way. (You may create a continuous line by selecting a point on a well that is shared by two panels, but again, you will be drawing in individual panels.)

To start drawing a line click on the button Line +. As long as you do not click on the same button again, the points that you will be making using the mouse will belong to the same line. Make several points with the mouse until you create a line. One such line is shown in Figure 17-23. To draw another line, again click on the button Line +. In

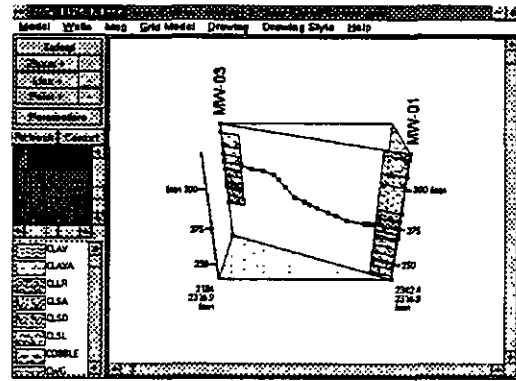

Figure 17-23

plotting terminology this is equivalent to Pen Up. Clicking now with the mouse on the starting point of a second line is like the plotting command Pen Down. An example is shown in Figure 17-24.

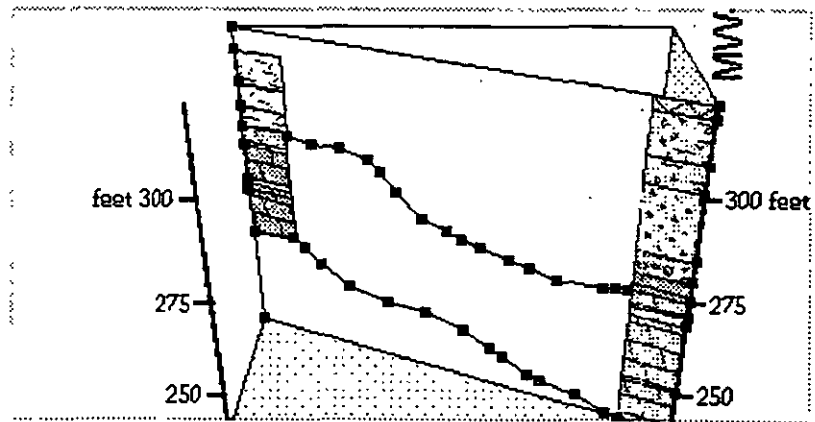

Figure 17-24

To delete a line click on the button Line - and click on one or more points on the line you wish to delete. The line will be deleted but the points will remain visible. Alternatively you may select the command Clear panels in which case all what you have added to each displayed panel will be erased.

17.2.12. Filling with Lithologic Patterns

Very often you will want to fill a lithologic unit or a layer with its pattern. The filling is done in closed polygons. To fill the layer in Figure 17-24 with the pattern for dolomite you need to add two more lines, each connecting the top with the bottom of dolomite in both wells. If you do not close the polygon correctly the color and pattern will spill and cover the whole panel. If this happens you will have to clear this panel. However, remember that the command Clear Panels will clear all panels that are currently displayed (or which make your current working group of panels).

When you have a closed polygon, you may select one of lithologic patterns which are displayed in the lower part of the left-side window. Click on dolomite, e.g., notice that the symbol name becomes dimmed and click inside the polygon on the panel. This acts as a paint brush. The final display is as shown in Figure 17-25.

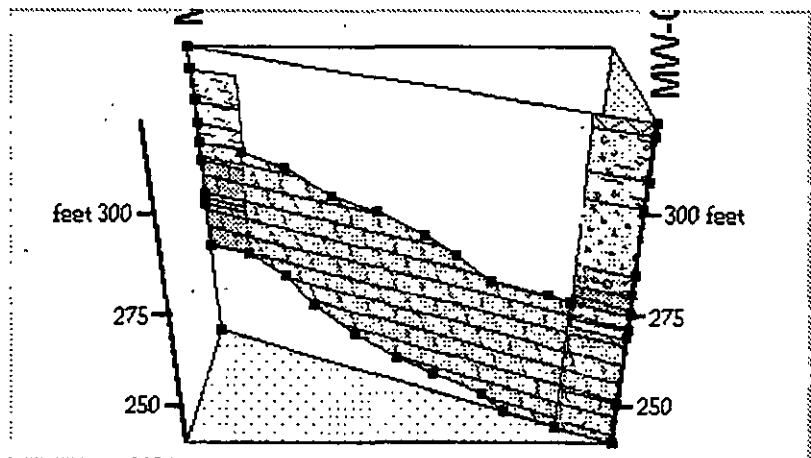

Figure 17-25

17.2.13. Fine Tuning of Points

You may fine tune the position of points and lines by using the button Select. After you press on Select you may drag any point on a line. Figure 17-26 shows one such

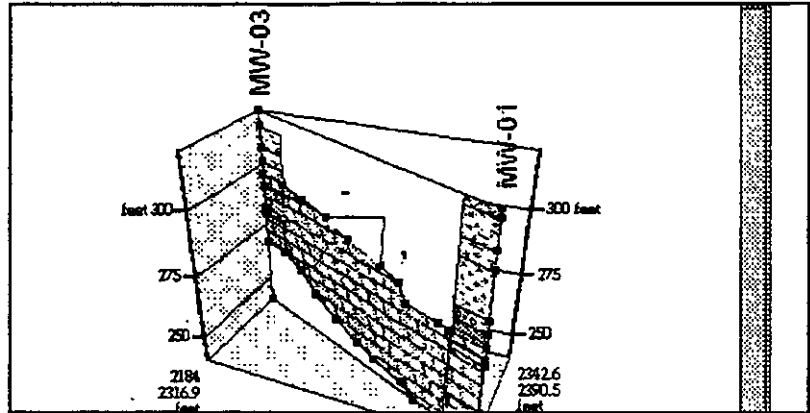

Figure 17-26

move. Figure 17-27 shows that by moving a point on a

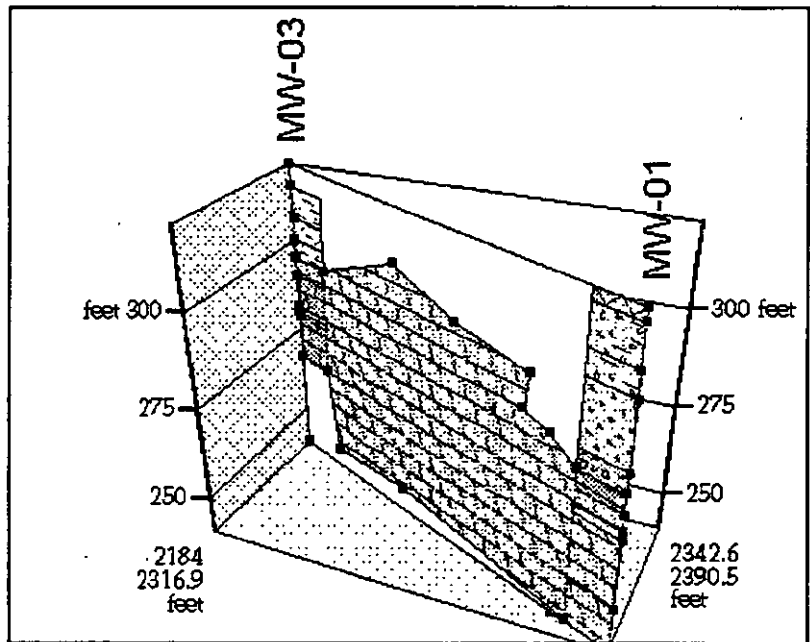

Figure 17-27

line which closes a filled polygon the new polygon becomes completely filled with the selected pattern.

- 17.2.14. Points** You have two additional buttons: Points + and -. Although points can be drawn using the Line + button, the button Points + draws but does not connect points. Likewise, the button Points - erases a point but not the line.

17.3. WELLS MENU

To select wells to be used on a fence diagram is normally the initial step in using this application. You have only two options on this menu: to select wells that will make a working set, and to select wells that will make a working group (Figure 17-3). You can make a working group only from wells that make a working set.

17.3.1. Select Working Set

You use the select Working Set option in the same manner as in any other application. Its use is explained in Chapter 5, section 5.3. Its purpose is to reduce a large set with many wells to a smaller set of wells which may be selected for any reason.

17.3.2. Select Working Group

Only the wells that are included in a working group can be added to a fence diagram. You may select a working group in several ways. One would be to use this option on the Wells menu, and manually pick wells one by one from the Unselected list of wells. The other would be to use this option and apply one of selection conditions. For example, you could use well names, X and Y coordinates, type of aquifer and the like.

An alternative to selecting wells by names or identification using this menu is to select them directly from a map. This will be explained in Section 17.4. Whichever method of selection you choose, the list of selected wells will look something like what is shown in Figure 17-28.

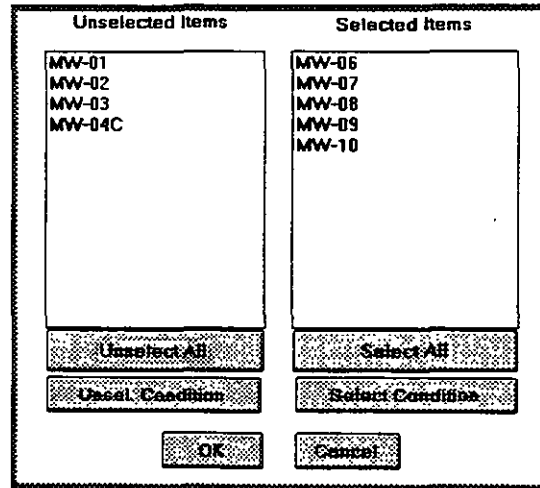

Figure 17-28

17.4. MAP MENU

On this menu you have three options:

- Load Map
- Select Working Set From Map
- Select Working Group From Map

The **Load Map** option is a general option for selecting wells either to make a **Working Set** or a **Working Group** of wells. Prior to clicking on **Load Map** you should click on either **Select Working Set from Map** or **Select Working Group from Map** to make a working set of wells (a larger group) or a group of wells (from among a working set) that will be plotted on a fence diagram.

When you click on either **Select Working Set** or **Select Working Group** nothing visible will happen. GWW is only prepared for your next move, that is the real selection from a map.

17.4.1. Load Map

This option is used for two purposes:

1. To create a working set of wells directly from a map.

2. To create a working group of wells directly from a map.

17.4.2. Select Working Set from Map

The sequence is normally:

1. Click on **Wells** to open the menu.
2. Click on **Select Working Set** and Unselect all wells. This is important because any selection adds new wells to the existing working set.
3. Click on **Map** to open the menu.
4. Click on **Select Working Set from Map**. Nothing happens.
5. Click on **Load Map**. Wait for the dialogue box to list available maps.
6. Select one of maps listed.
7. Select wells to make a working set using either **Rectangle**, **Points**, or **Area**. In the case of **Points**, use other buttons on the right side to complete the selection (**End Points**). In the case of an **Area**, after you circle an area (remember, in clockwise direction you are selecting within the area; in the counterclockwise direction outside the area!) you should close the area (**End Point**) followed by **End Digitizing** button.
8. Click on **Select Working Set** on the **Wells** menu to check whether these are the wells you wish to work with when creating a fence diagram.

17.4.3. Select Working Group from Map

The sequence is normally:

1. Click on **Wells** to open the menu.
2. Click on **Select Working Group** and Unselect all wells. This is important because any selection adds new wells to the existing working group.
3. Click on **Map** to open the menu.

4. Click on **Select Working Group** from **Map**. Nothing happens.
5. Click on **Load Map**. Wait for the dialogue box to list available maps.
6. Select one of maps listed.
7. Select wells to make a working group using either **Rectangle**, **Points**, or **Area**. In the case of **Points**, use other buttons on the right side to complete the selection (**End Points**). In the case of an **Area**, after you circle an area (remember, in clockwise direction you are selecting within the area; in the counterclockwise direction outside the area!) you should close the area (**End Point**) followed by **End Digitizing** button.
8. Click on **Select Working Group** on the **Wells** menu to check whether these are the wells you wish to display on a fence diagram.

17.5. GRID MENU

Using this option and the subsequent option from this menu you will add one or more lines to your cross section. The menu has only one option:

- **Get Intersection Line**

The sequence of operations is normally the following:

1. Select **Get Intersection Line**. A dialogue box is opened with the list of available grid models (these grids are created in the Mapping application by making a grid model from random point values).
2. Select one of available lines to plot. This line will be automatically displayed on the fence diagram. However, remember that for plotting a line the option **Skip Undefined Polygons** on the **Drawing Style** menu must not be checked.

The lines that you may normally display could be the following:

- ground surface elevation;
- water level at one or more dates; pre-pumping and post-pumping water level showing a cone of depression;
- lithological contacts between formations;
- stratigraphic contacts between stratigraphic units;
- top and bottom of an aquifer.

You may display or add to a fence diagram one or many such lines as shown in Figure 17-29.

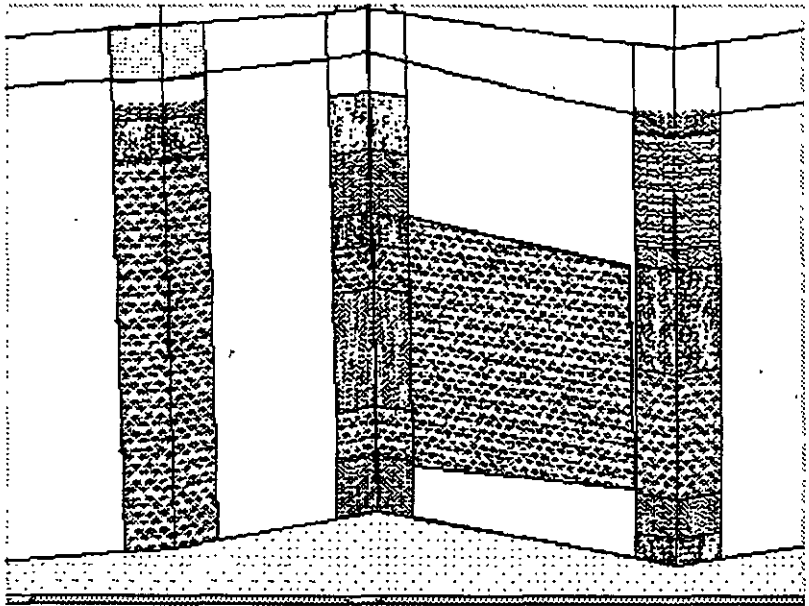

Figure 17-29

17.6. DRAWING MENU

Using this command you will finish your drawing which you have created by selecting wells, making panels, selecting scales and orientation, and other attributes. Here

you will make legend blocks to enhance the drawing. In this menu you will also save the drawing by assigning a name. You will setup your printer and print the drawing.

17.6.1. Make Drawing

With this command you are switching from the main menu view to the drawing view. The whole screen becomes your drawing area. You may add lithology, header, scales, and any text you find appropriate. Wait until GWW recalculates the drawing and displays a dialogue box, Margins, on the screen.

17.6.2. Drawing Margins

You will be first prompted (Figure 17-30) to confirm the margins of the drawing. Margins in this operation imply the amount of shifting the drawing left, right, up, or down within

Margins (mm)	
Left	0
Above	0
Right	0
Below	0

Cancel
OK

Figure 17-30

the printing form field. The shifting of the drawing becomes handy when you wish to make space for legend and text blocks. Remember that the drawing you are going to create will be saved and associated with a drawing's name but it will not become a part of the information system which you can later edit. In other words, the 3D drawings are not like 2D cross sections (application Cross Section) or maps (application Mapping). They are like "nonstandard" drawings: a pumping test, a hydrograph, a chemical diagram and a step draw-down test diagram. You may print them provided you

create a reporting form in the Cross Section application and select **Drawing** option under **New Field** menu.

17.6.3. Save Drawing As ... When you create a new fence diagram you may want to save it for printing. The only option available for saving is **Save Drawing As ...** after which you are prompted to give a name to the drawing.

17.6.4. Make Legend To create a legend block you must start with **Make Legend** option. Using this option you will position the legend block (box) onto the drawing, assign its X and Y size, and add some offset to the frame to move it from the drawing's frame. You may make several legend blocks and place them on the same drawing, but you must finish the complete creation of one block and fill its content before you can create another block. One of **Make legend** dialogue boxes prepared for the lithology description is shown in Figure 17-31.

Legend Parameters

Relate corner points of map and legend

Map Corner Point	Legend Corner Point
Lower Left	Lower Left
Upper Left	Upper Left
Upper Right	Upper Right
Lower Right	Lower Right

Additional Offset [mm]
 X Y

Legend Field Dimension [mm]
 X Y

Font
 OK
 Cancel

Figure 17-31

1. Unless you are already in the **Make Drawing** mode you should select **Make Drawing**. The option **Make Legend** becomes available.
2. Select **Make Legend**.
3. In the dialogue box titled "**Legend Positioning**" select in which corner of the drawing you wish to place the legend. You have four options: lower left, upper left, upper right and lower right. You have also the option to move the block from the selected corner both in X and Y directions, that is you may place the legend to any part of the drawing.
4. In the same dialogue box decide which corner of the legend block will coincide with the selected drawing point. For example, if you select Lower Left corner of the drawing and Lower Left corner of the legend block, and leave blank additional offset fields, the legend block will have its lower left corner in the lower left corner of the drawing and will extend to the right and above from this "origin". If you select upper right corner of the drawing and upper left corner of the legend block, the legend block will extend beyond the cross section drawing to the right.
5. Select the offset in X and Y directions from the selected drawing corner points. The offset is in millimeters.
6. Select the size of the legend block. Fill in the fields for X (width) and Y (height) size.



*NOTE 1. You may not like the position or the size of the legend block. You cannot erase the block without clearing the whole cross section. It may happen that the frame of the legend block or its content will not be fully displayed on the screen after the block is created. Click on **Fit Wnd** button on the right to refresh the screen.*



NOTE 2. If you do not specify the "Legend Field Dimension" but leave the two fields blank, you will be able to create a legend block without the frame. This may be very handy if you are not sure what size of the block is needed for the text that you intend to write.

17.6.5. Write Text To Legend

If you have created a legend block by using the option **Make Legend** you may add some text to the legend.

1. Select **Write Text to Legend**. Type some text onto the line in the **Text to Legend** dialogue box.
2. Click on **OK** or press **ENTER**.
3. The **Font Selection** dialogue box offers you to select a font from one of installed fonts. Select font family, size, and style. Keep in mind the size of the legend block and the length of the text string that you just typed.

NOTE. The screen display in some parts of GWW is not *What You See Is What You Get* (WYSIWYG). This is especially true for the legend. It may appear that the text string extends beyond the legend box frame. To see whether this is the case refresh the screen by selecting either **zoom in** or **zoom out** buttons on the right and by viewing the enlarged legend block.

You may write several lines of text to the legend block provided you have assigned enough space for the block. One typical line might be the word **LEGEND**.

17.6.6. Write Scale to Legend

The program knows which scales are used for drawing a fence diagram. When you select **Write Scale to Legend**, GWW will offer a default text for the horizontal scale, followed by a default text for vertical scale. You may accept these text options by pressing **ENTER** or clicking on **OK**, or you may override them by typing something else.

At the end the program will open a font selection dialogue box giving you an opportunity to select font family, size, and style.

17.6.7. Add Lithology to Legend

Using this option you will be prompted to select lithological symbols that may appear on the currently displayed fence diagram to have them become a part of the legend.

The procedure that follows assumes that you have an active legend block created by using the option **Make Legend**. If not, create first the legend block and position it on the screen.

1. Select **Add Lithology to Legend**. A dialogue box titled "Select Lith. Units" will display a list of all lithologic symbols that you have made a part of your data base when you have created well logs using the **Well Log** application. This is the same list of wells which is copied from the ASCII file LITH.DLT as distributed with the program, unless you have used another file created by you. The dialogue box may look as shown in Figure 17-32.

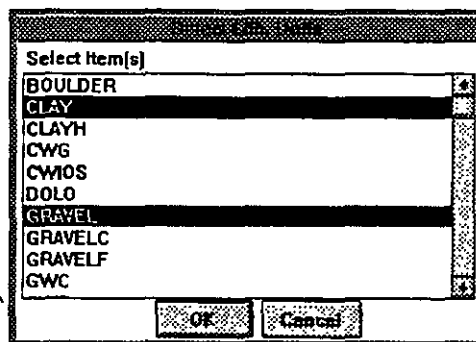

Figure 17-32

2. Click with the mouse on a symbol that you wish displayed on the cross section. You should click on all symbols that you wish to place on the legend before you select OK. This ensures that symbols will not be separated in the vertical succession within the legend. Select OK. Remember that by default GWW cre-

ates one symbol 5 mm high. Thus if you wish to place 6 lithologic symbols on the legend, you need to create a legend block with minimum height of 35 mm.

3. The program offers now "Legend text for ..." the symbol that you selected, and places the default text associated with this symbol. You may confirm it by pressing ENTER or clicking on OK button, or you may type another text. Here again you may use language other than English! After the last selected symbol is confirmed, the program will automatically add these symbols onto the currently active legend block. Figure 17-33 displays a legend block created to de-

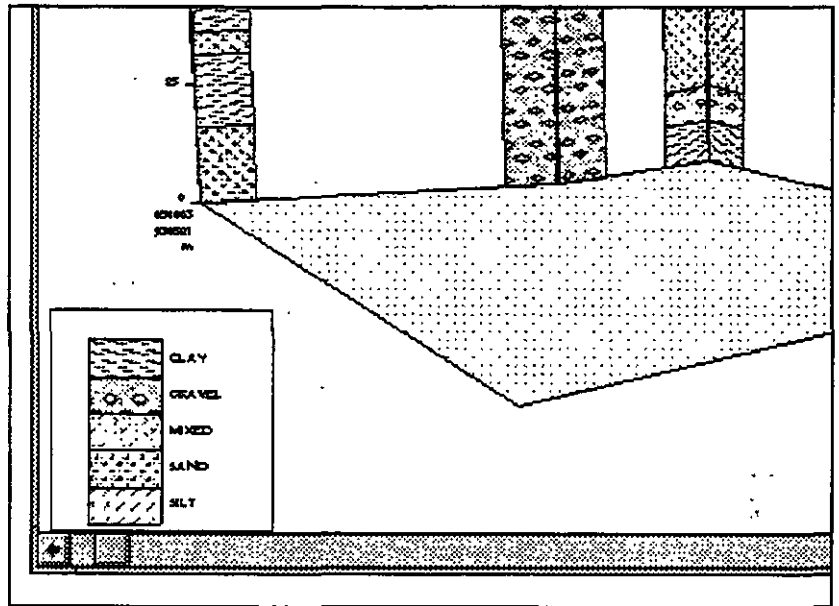

Figure 17-33

scribe various lithological units that may appear on the fence diagram.

NOTE. If you wish symbols to be separated one from the other by 5 mm, select only one symbol and press ENTER, then confirm the text. Repeat with the second symbol, the third until you select all symbols. The symbols will appear as 5 mm blocks separated by another 5 mm of blank space in the vertical succession.



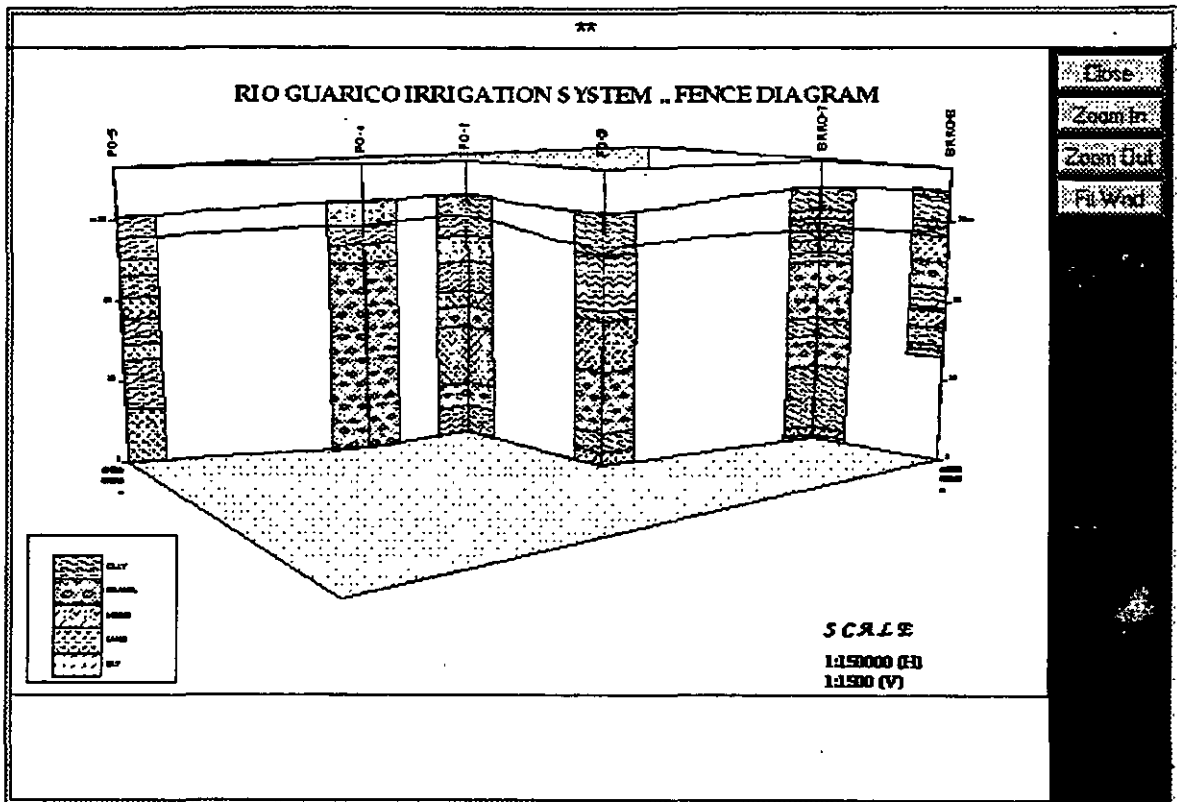

Figure 17-34

A completed fence diagram with a header, legend block and a scale block is shown in Figure 17-34.

17.6.8. Print Cross Section

When you decide to print a 3D cross section, the program will display the list of all available reporting forms as shown in Figure 17-35. You may select one of the

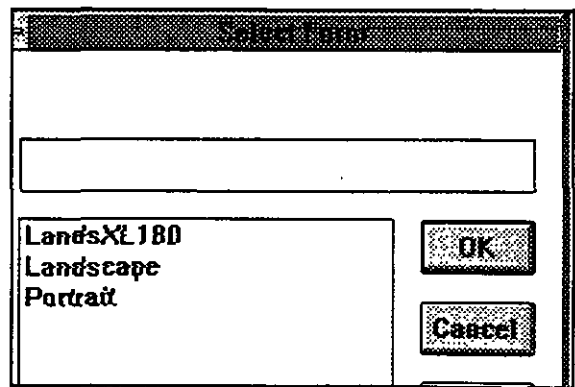

Figure 17-35

forms, and the program will print the report. You create reporting forms using the **Tools** option on the **GW** main menu, then **Report Forms Editor**, then **Cross Section**.



*NOTE. You may place a fence diagram title directly on the drawing using the **Make Legend** and **Write Text to Legend** options. Or you may create a header or text field in the cross section reporting form. The first option is handy to make a one-line title. The second option is useful for making a title with one or more lines using object field attributes (alignment, fonts, colors, border line thickness, shadow and the like.).*

17.6.9. To Setup a Printer

Selection of printers and attributes related to printing is normally a Windows operation. You may set up your printer parameters from Windows, prior to running the **GW** program. To do this:

1. From **Main group** select **Control Panel**.
2. Select **Printers**.
3. Select one of installed printers as a default printer, or add some more printers to match your hardware.
4. Select **Setup** and modify whatever you want to modify.
5. Click on **Set as default**.
6. Close **Printers** and **Control Panel**.

You may do about the same from inside the **GW**. From within the **GW** you use **Printer Setup** to change the orientation of printout, portrait (vertical) or landscape (horizontal), the printing medium, the quality of print,

number of copies, colors for a color printer, and many more. You cannot change the default printer!

The dialogue box for selecting printer parameters is shown in Figure 17-36 for Hewlett Packard Laserjet III printer.

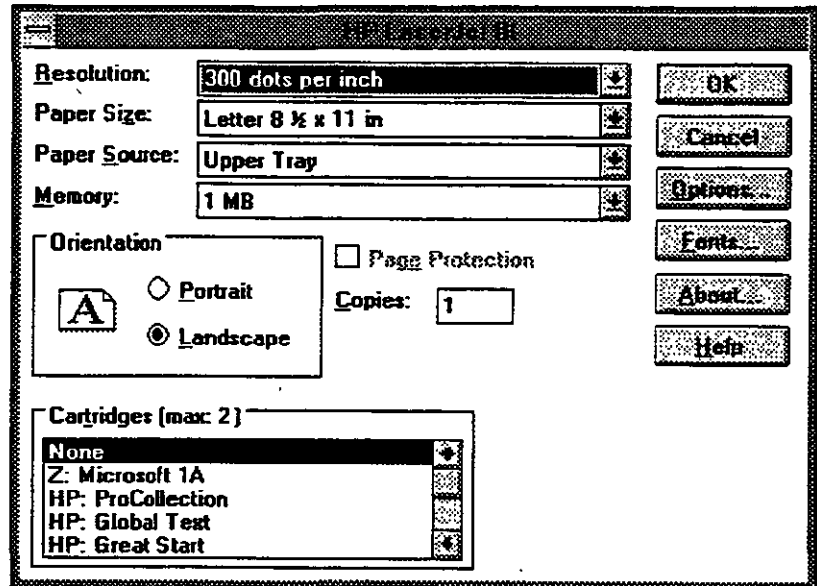

Figure 17-36

17.6.10. Dimensions of the Cross Section

You will use this option frequently to check the size of the drawing. The numbers are in centimeters by default. The following is important to keep in mind: cross sections are printed using either a default reporting form or one which you created. When you create a reporting form, you assign the dimension and position of the drawing field. The dimensions assigned using the **Tools** option on the main menu and **Report Form Editor** should match the dimensions of your current cross section in order to print its whole content.

For example, currently you have a cross section reporting form as a part of the GWW.000 template, which is prepared for the drawing size 250 mm horizontally by

154 mm vertically in landscape orientation, and 180 mm horizontally by 250 mm vertically in portrait orientation. If your drawing's dimensions, as displayed using this option, are less than the reporting form's drawing field, the cross section will be centered within the drawing field. If they are greater than the drawing field, a portion of the cross section will not be printed. What will be printed will start at the lower left corner of the reporting form's drawing field.

In this application you may control the dimensions of a drawing by selecting different horizontal scale (of the XY plane) and by changing the angle of rotation. Changing the vertical scale you will not control the vertical (Y) size of the drawing, or at most you will indirectly change the size. The Drawing Dimension dialogue box looks as shown in Figure 17-37.

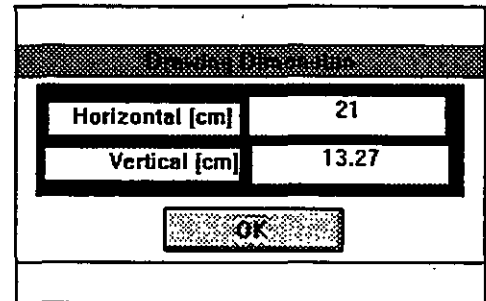

Figure 17-37

17.7. DRAWING STYLE MENU

17.7.1. Draw Lithology Pattern

When you check this box lithologic units/members will have lithologic patterns (symbols) drawn. These are the same symbols that you are using in Well Log application and Cross section application.



NOTE. You are advised to remove the check from this box when you are still working on a drawing. It takes time to draw lithologic patterns and symbols. Only when you are satisfied with the drawing, its legend, and other text you may add lithologic symbols. But add lithology before you go to Make Drawing menu. There you may also add lithology but it will not be printed unless you close the Make Drawing menu and open it again.

17.7.2. 2D Drawing

When you select this box the angle of orientation along the X axis will be returned to 90 degrees. The cross section will become similar to the standard Cross Section application, except that in this application you may connect lithologic units, fill them with symbols and pattern, and add some free-hand drawn lines.

If you check the option Parameters, you will notice that the "Around X axis" angle was set to 90.

17.7.3. Skip Undefined Polygons

Some of polygons may be undefined. You are advised to keep this box unchecked, which would be interpreted as "Do not skip undefined polygons." You certainly need to keep this box unchecked if you wish to add some "intersection" lines, that is the ground surface elevation, some water level at a certain date, lithologic members and the like.

17.7.4. Skip Lines Below and Above Log

Some polygons may extend above the ground surface elevation and may have lithology undefined. Checking this box will prevent such polygons from being drawn.

7.7.5. Fill Panel Background

Leaving this box unchecked panels will be left transparent, that is without sides. Every well which would be covered by a front-drawn panel will be visible. Yet you will loose "three dimensionality."

17.7.6. Well Column Width

Just the same as in the Cross Section application you may control the width of well columns. The default is 10 mm.

1. Select Drawing Style.
2. Select Well Column Width.
3. Type the new number. Take care not to select a too large width in which case you may overlap columns.
4. Select OK.



NOTE. You may use "zero" column width for special purposes.

CHAPTER EIGHTEEN USER DEFINED APPLICATION

18.1. INTRODUCTION

- 18.1.1. General** *Ground Water for Windows (GWW)* allows you to create your own applications in which you will store, process and manage data other than chemical, lithologic, water level, hydrogeologic, pumping test, or grain size. Notice on the Main menu of GWW under the Applications sub-menu the last entry, **User Data**, Figure 18-1.

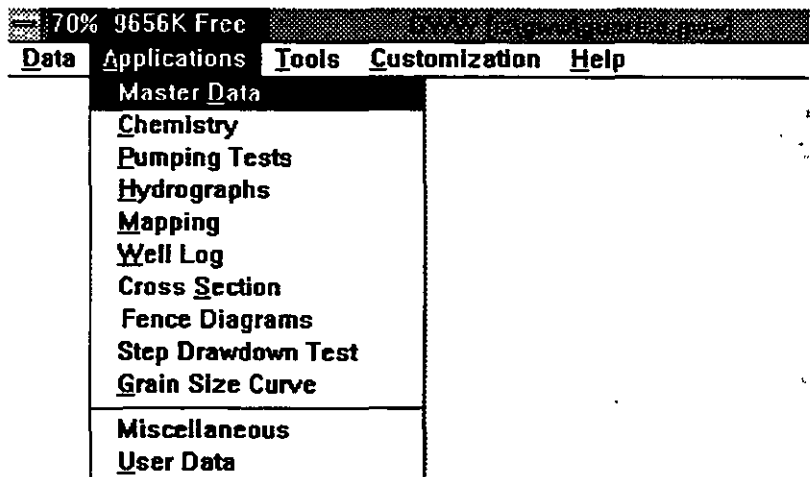

Figure 18-1

Creating one or more of your own applications, you may keep data that belong to a specific category under its own header. For example, climatological data such as rainfall, evaporation, air temperatures, etc. for a project or a country can be kept within an application titled Climatology. Geotechnical data on samples from drilling,

such as Atteberg limits, water content, friction angle, cohesion, etc. can be kept in a separate part of the data base under the title Geotechnical. Surface water data for a project site or a larger area can be kept in a Surface-Water application.

**18.2. PREPARING
GWW FOR NEW
APPLICATION**

The **User Data** application uses all routines and utilities which are common to other components of the GWW system. You may make a random model for user-data-specific entries, use this model to create location or contour map for your data, print reports with data in tables or in any other format designed by you.

However, before you start input of new data you must prepare the data base for a new application. The first step is to go to **File Structure Editor** and create a new data structure for an application.

1. Select **Tools** under the Main menu.
2. Select **File Structure Editor**.
3. Click on **File**. Notice on the menu which is as shown in Figure 18-2 two additional entries: **New User File** and **Old User File**.
4. Select **New User File**. GWW opens a dialogue box as shown in Figure 18-3 prompting

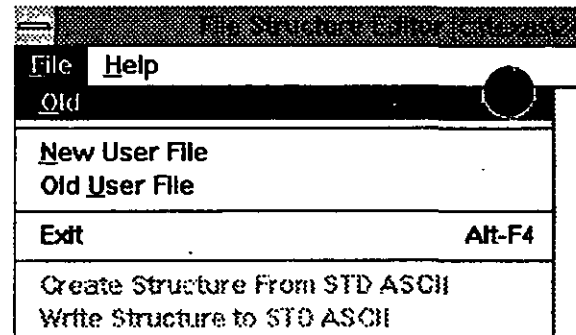

Figure 18-2

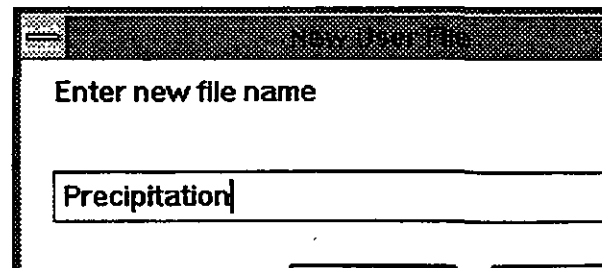

Figure 18-3

you for the name of your to-be-created application. In the case used for this example the name will be Precipitation, actually an application for storing and processing rainfall and evaporation data. Immediately after you type a name for a new application and click on OK, GWW will display the data structure with only one data item, Well Ident, as shown in Figure 18-4.

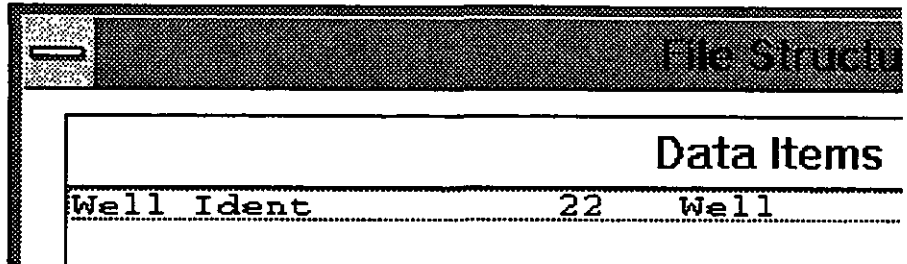

Figure 18-4

5. Select New and start creating a new data structure. When you are finished, the dialogue box may finally look as shown in Figure 18-5.
6. Click on OK and exit the File Structure Editor.

The next step is to create a new entry form. This step can be omitted if you are satisfied with what GWW will offer by default. If you wish to create a new entry form do the following.

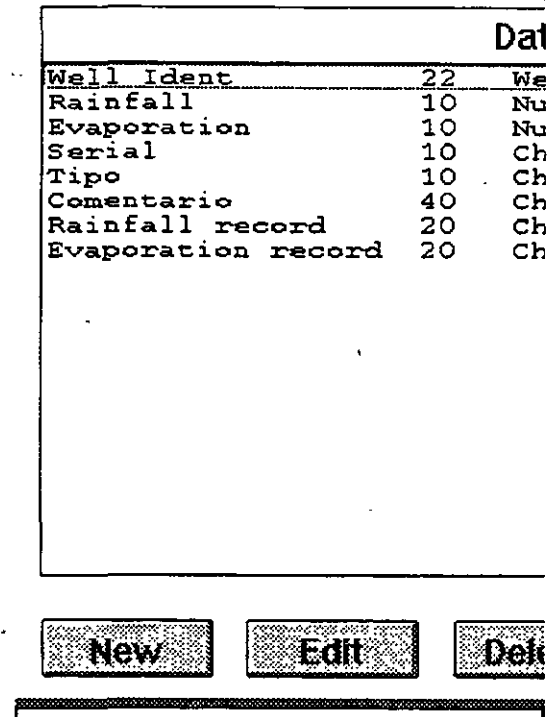

Figure 18-5

1. Select Tools from the Main menu.
2. Select **Data Entry Forms Editor**. Notice the last row, User Data, Figure 18-6.

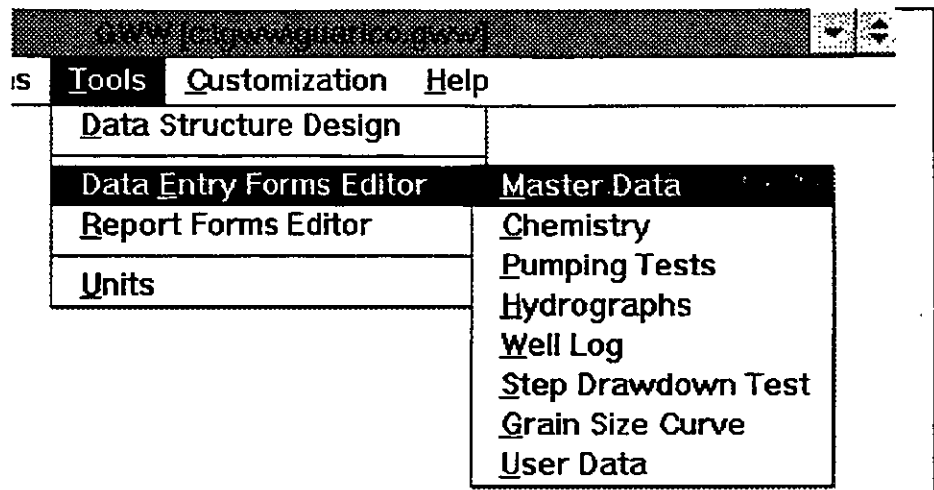

Figure 18-6

3. Click on **User Data**. GWW will open a dialogue box prompting you to select one of user-defined applications. GWW knows which applications you have created by making new file structures. In this case only one application will be listed with the name Precipitation as shown in Figure 18-7.

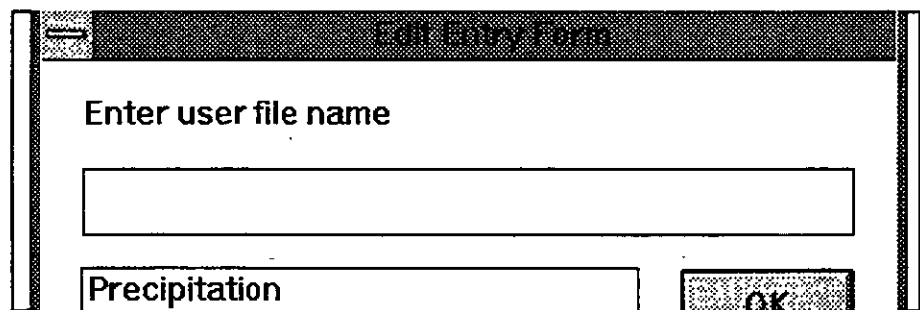

Figure 18-7

4. Select Precipitation from the list of user-defined applications.

- Now you may create a new entry form using any of data fields displayed in the left-side window. The single fields are shown in Figure 18-8. The creation of entry forms is explained in details in Chapter 3.

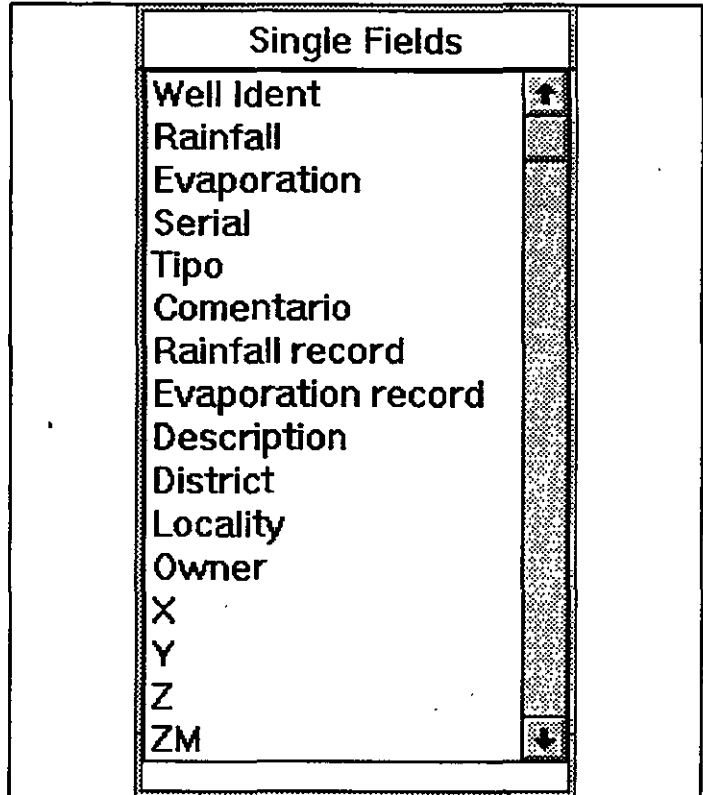

Figure 18-8

- After you create an entry form save it using the option **Save As ..** under the File menu.

The final step in preparing GWW for this new application is to create one or more reporting forms.

- Select **Tools** again on the Main menu.
- Select **Report Forms Editor** and notice the last row, **User Data** which expands to **Single Record Report** and **Table Report**, Figure 18-9.

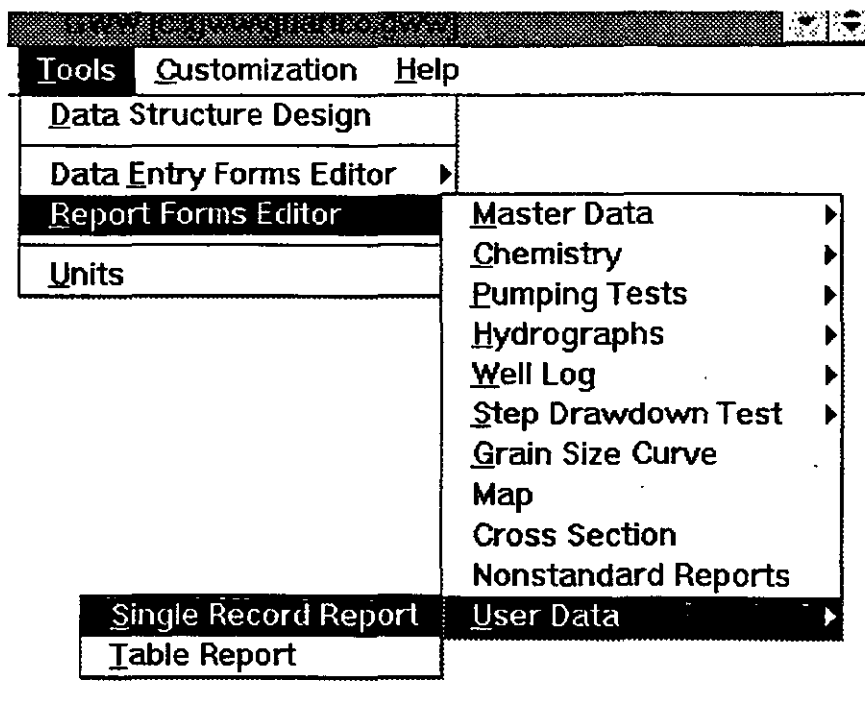

Figure 18-9

3. From the list of applications select the one that you wish to create a reporting form for. In this example this will be the application titled Precipitation.
4. Create a report form as explained in Chapter 3.
5. Save this form using the option **Save As ..** on the File Menu.

Now GWW is prepared for this new application

18.3. APPLICATION'S CONTENT

Since you may create more than one user-defined application, after you select User Data on the Main menu GWW will display a dialogue box, as shown in Figure 18-10, with the list of all newly created applications. When you click on Precipitation and confirm the selection by clicking on OK, the display is as shown in Figure 18-11. The User's application main menu is comprised of the following major options:

Enter user file name

Precipitation

Precipitation

OK

Figure 18-10

User Files. Precipitation

Data Units Report Make Random Load Map Help

0/8	User Files. Precipitation		
Bancos de San Biologica Los L	Well Ident	Rainfall	Evaporation
Corozo Pando	La Candelaria	1144.00	2764.00
El Manguito	Serial	Tpo	
El Rastro	3438	PR	
La Candelaria	Comentario		
La Mision	Eliminada Enero 1991		
Los Naranjos	Rainfall record	Evaporation record	
	1982-1991	1982-1991	

Figure 18-11

- Data
- Units
- Report
- Make Random
- Load Map
- Help.

The Entry form is the GWW's default form.

18.3.1. Data The following options are available on the Data sub-menu:

Select Working Set. This is explained in Chapter 5, section 5.3.

Delete record. This is used to delete an entire record from the data base. However, deleting a well from the UserData application will not delete this well from the data base, if the same well is used in some other application. If you wish to delete a well completely the best way is to delete it from all applications other than the Master Data. When it disappears from all applications, only then you should delete it from the Master Data.

Select Entry Form. You may have more than one Entry Form in your data base for this particular application. When you activate this option a dialogue box with all available entry form names will be displayed for you to choose from.

Standard ASCII Input and Standard ASCII Output are explained in Chapter 5, section 5.5.

Printer Setup. This is explained in Chapter 5, section 5.4. It is a standard Windows routine which displays the dialogue box of the printer driver that you have selected to be the default printer in Control Panel of the Windows Main Menu.

Exit. Selecting this option or pressing ALT+F4 will terminate the work in this application and return you to the GWW main menu.

18.3.2. Units You may view or modify currently selected units. The dialogue box as displayed in Figure 18-12 will be opened.

18.3.3. Report The following options are available on the Report sub-menu:

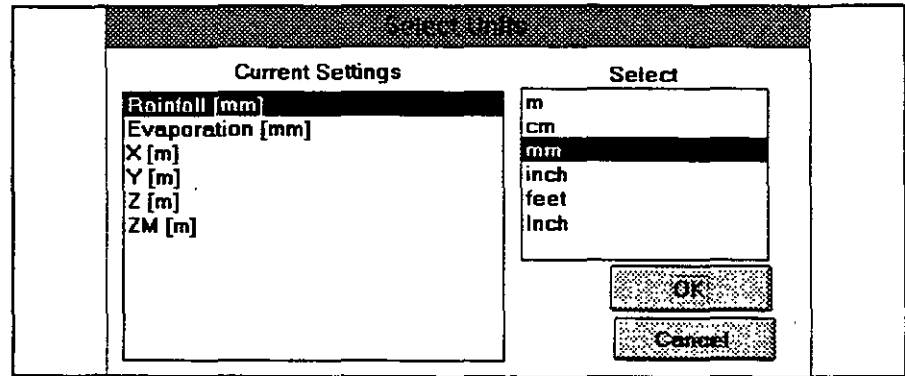

Figure 18-12

- Print Report
- Select Table Form
- Select Record Form

The differences between these options are explained in Chapter 6, section 6.4.3.

18.3.4. Make Random This option is discussed in Chapter 5, section 5.6. It is one of the most important options provided in the user-defined applications. Using this option you will create an internal file which contains random points and their X and Y coordinates, well identification and a space-dependent numerical parameter. This parameter may be average annual rainfall for a climatological station, average annual evaporation, or anything else, depending on which data you are storing in this application.

When you select Make Random option GWW displays a dialogue box, as shown in Figure 18-13, with the list of all space-dependent parameters for this and Master Data applications. Entry Rainfall is selected to create additional figures included in this chapter.

18.3.5. Load Map

This option, which is discussed in Chapter 5, section 5.3.2, is also one of the important features of the GWW system. It permits you to reduce a large set of data (wells, samples, stations) to a smaller set directly from the map.

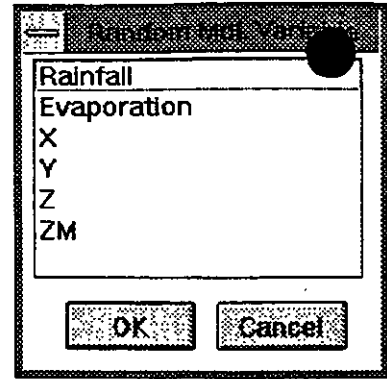

Figure 18-3

18.3.6. Help

This is a context-sensitive help which contains most of the explanations, procedures and routines that are applicable to the user data application.

18.4. USING STORED DATA TO CREATE THEMATIC MAPS

After rainfall data, e.g., are entered and a random model created using the data entry Rainfall, you may use the Mapping application to create two maps: (1) Location map showing locations of meteorological stations and their names (see Figure 18-14), and (2) Contour map of average annual rainfall expressed in mm/year (see Figure 18-15).

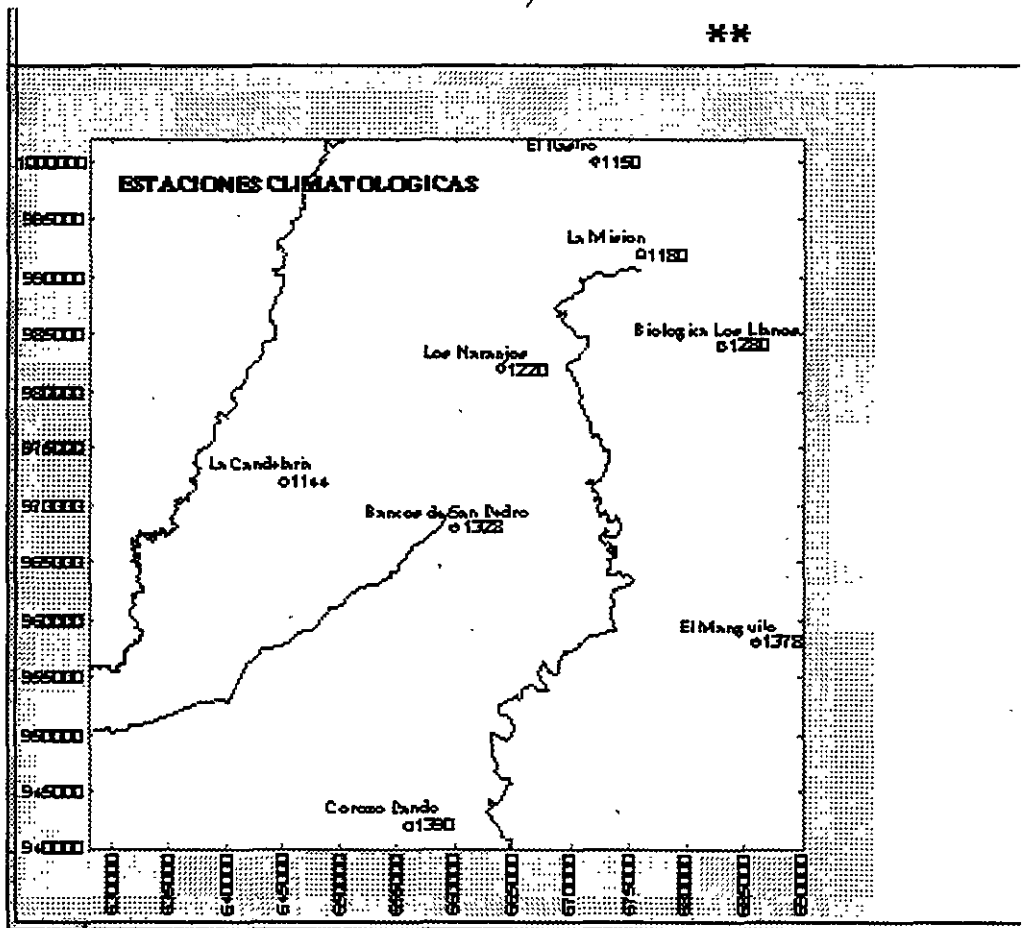

Figure 18-14

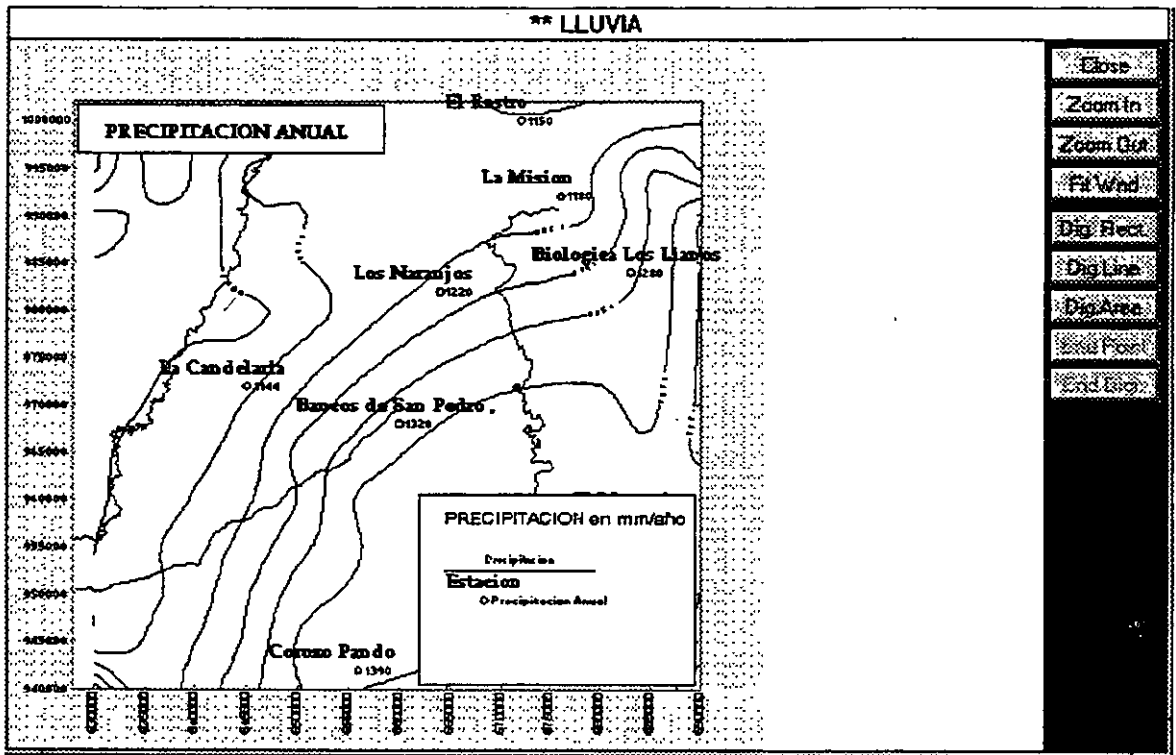

Figure 18-15

19.1

INTRODUCTION**19.1.1. General**

Using this application you may create a data base with various chemical constituents related to the depth of sampling. This is especially important in cases when the sampling is repeated over the drilled hole depth, and samples are taken from soil and water as the drilling progresses. Likewise, in saline water environments such as in coastal aquifers, the salinity stratification is often the case.

The data base is in a form of individual tables; one for a well, plus some general information that may also be a part of the data base. The display is user-designable. You decide whether you wish to display one or more constituents on the same diagram, whether you wish to use bar or line graphs, and whether the scale will be linear or logarithmic. You may display one or more constituents as linear graphs, and another as logarithmic. That is, each constituent may be assigned its own attributes for presentation.

As in other parts of GWW, you may create graphs and save them for later printing.

This application is a part of the Chemistry application. It branches off from Chemistry as shown in Figure 19-1. To activate it, you should select Applications, then Chemistry, and then Concentration-Depth.

**19.1.2. Application's
Content**

As shown in Figure 19-2, the Concentration-Depth application is comprised of the following major options:

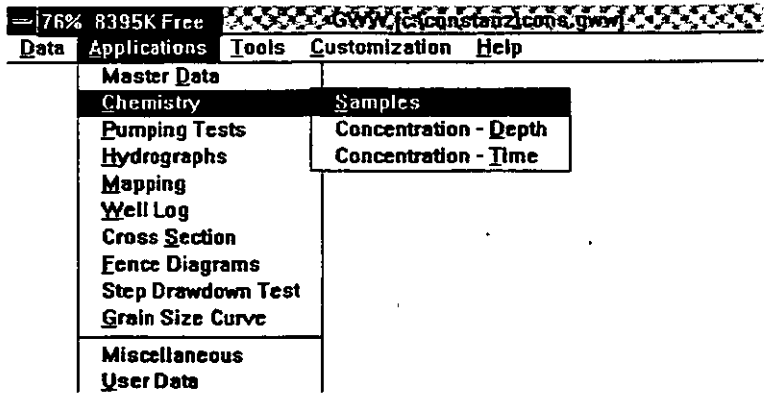

Figure 19-1

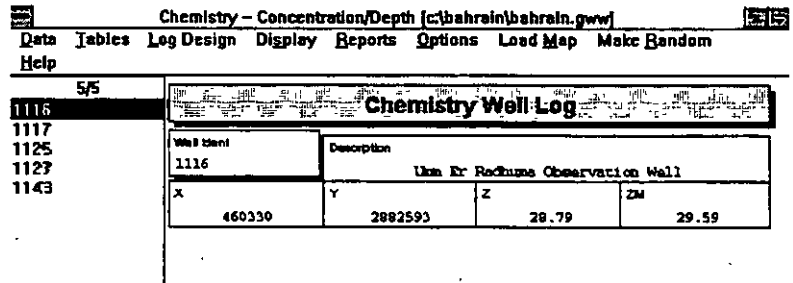

Figure 19-2

- Data
- Tables
- Log Design
- Display
- Reports
- Options
- Map
- Make Random
- Help

Prior to using this application you must modify the file structure for "concentration - depth series" to make it

compatible with the parameters that you wish to store, display, and retrieve as reports.

From the Main menu on GWW, you should select Tools, followed by Data Structure Design. This activates the file structure editor. Select Files, followed by Old. From the list of internal data structures select the one labeled Chem_Conc_Depth_Tab. In the default template, GWW.000, which comes on the distribution diskette, the only entry that is prepared is Depth. Using the editor create your own list of chemical constituents that you wish to store in the data base. One of such lists is shown below.

Depth	10	Num(Dim)	Fixed 2	m
Cl	10	Num(Und)	Fixed 2	
Na	10	Num(Und)	Fixed 2	
TDS	10	Num(Und)	Fixed 1	
Conductivity	10	Num(Und)	Float 1	

As it is prepared, one may store, display and report data on chloride, sodium, total dissolved solids, and on conductivity of water.

The Data menu is shown in Figure 19-3. In this menu you

Chemistry Concentration/Depth (C:\ghwain\ghwain)				
Data Tables Log Design Display Reports Options Load Me				
Select Working Set				
General Data Units		Chemistry Well Log		
Select Entry Form		Description		
Delete Record Ctrl-D		Units	Er	Redtime Obs
Standard ASCII Input		Y	Z	
Standard ASCII Output		2892593		28.7
Printer Setup				
Exit Alt-F4				

Figure 19-3

select your current working set (reduce a large set to a smaller, thematic set). You may check which units are

currently used for general data (sampled well coordinates and elevations). You may select one of entry forms that you may have eventually created. You may also delete a record. You may read general data on sampled wells (coordinates, elevations, descriptions, names, etc.) from an ASCII file, or you may save such data to an ASCII file. This menu deals with wells and not with tables. A table is the place in which you type chemical constituents as a function of depth. This latter is done using the menu Tables.

The Tables menu is shown in Figure 19-4. Using this menu you either type your data, edit table, add or re-

Chemistry - Concentration/Depth (C:\bahr\h\bal)			
Data	Tables	Log Design	Display Reports Options Load
Help			
	Insert Row	Ctrl-I	ents
	Delete Row	Ctrl-D	
70.00	Save Data	Ctrl-S	0.0 14
1	Exit (don't save)	Ctrl-X	0.0 16
1			0.0 17
1			0.0 22
2			0.0 34
2			0.0 73
2			0.0 116

Figure 19-4

move some rows in the table, save data, exit (close) table, and check or modify units used for depth. Just the same as in other applications, you may save your tables (depth-concentration data) and/or import them as ASCII files.

The Log Design menu is shown in Figure 19-5. The com-

Chemistry - Concentration/Depth (C:\bahr\h\bal)			
Data	Tables	Log Design	Display Reports Options Lo
Help		New Log Design	
5/5		Old Log Design	
1116		Edit Log Design	Chemistry We
1117		Save Log Design	cription
1125		Save Log Design As...	Unit Er Radiv
1127			
1143		X 460330 Y 2002593 Z	

Figure 19-5

mands on this menu are used to customize the display and printout. The customization means, first, which constituents from a table you wish to display. For example, although you may have entered the values for Na, Cl, TDS, and conductivity, you may decide to display and/or report only total dissolved solids. Second, you may assign some attributes to the constituents to be displayed: line and fill color, linear or logarithmic display, bar or line type of graph, minimum and maximum concentrations to display, etc. You may also select the vertical scale for the graph, and control widths of individual columns used to display constituents. Finally, you may control the fonts used to label the graph. On this menu you design a "display" log, you edit it, save it, or select one of available designs.

The command Display does not have any other subcommands. It does what it says. It displays a graph with data from table connected to a currently highlighted sample, using the design for the graph as currently selected.

The Reports menu is shown in Figure 19-6. Using the commands on this menu, you may print a graph, or save it for future printing, or mixing with other graphs.

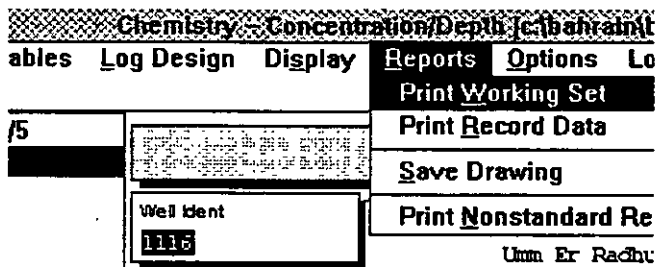

Figure 19-6

The Options menu allows you to switch between parts per million (PPM) and equivalents per million (EPM). Of course, this will apply only to charged ionic constituents for which conversion factors are available in the auxiliary file PPMTOEPM.TBL.

The Map menu is explained in Chapter 5, Section 5.3.2. It is used to load a map and select sampled points directly from the map.

The Make Random menu is also explained in details in Chapter 5, Section 5.6. It will be used for creating location or site maps showing sampling points at which depth-variable chemical data are available.

19.2. DATA MENU

The routines on this menu are equivalent to similar routines in other applications. For example, see Pumping Test, Hydrographs, Step-Drawdown, or Grain-Size application.

19.3. TABLES MENU

Using the commands on this menu you are creating your data base as it refers to concentration of selected constituents with depth. You may import an already created table as an ASCII file, one for a sample, or you may use the GWW editor.

- 19.3.1. Edit Table** When you select the Edit Table command for a new sample, the editor displays an empty table listing all constituents that you have listed in the Data Structure on the Tools menu. In the case of only four constituents selected (Na, Cl, TDS, and Conductivity), the table may look as shown in Figure 19-7. If you are going to edit an existing table filled with data, the display may look as shown in Figure 19-8.

1112 Chemical Constituents				
Depth (m)	Cl	Na	HDS	Conductivity
0.00	0.00	0.00	0.0	0

Figure 19-7

1143 Chemical Constituents				
Depth (m)	Cl	Na	HDS	Conductivity
0.00	6200.00	3100.00	11000.0	16900
150.00	10900.00	5200.00	18500.0	26900
210.00	21300.00	10000.00	34500.0	45600

Figure 19-8

To edit data, you use standard GWW commands: TAB to move from one field to the next, Shift+TAB to move backwards, CTRL+I to insert a line, CTRL+D to delete a line. The program does not check the sequence of depth entries. You are expected to use the logical sequence, from shallow to deeper.

19.3.2. Save Data When you finish typing the data you will save them using one of the two ways. The first is to press the Ctrl key and simultaneously press the S key. The other way is to use the mouse and click on Tables on the menu bar and click again on Save Data.

19.3.3. Exit without saving You may decide only to view the data without saving them. Again, you have two ways to do it. The first is to press the Ctrl key and simultaneously press the X key.

The other way is to use the mouse and click on Tables on the menu bar and click again on Exit (Don't save).

19.3.4. Standard ASCII Input and Output

The data tables can be created outside the GWW package using a text processor. The format is similar to the format in other applications. One such table is reproduced below.

<Depth>	<Cl>	<Na>	<TDS>	<Conductivity>
190.00	12200	6300	22600	29800
240.00	24300	12500	40000	51200
290.00	39300	20000	64500	73500

The first line is the header line which tells GWW what are the numbers that follow. As in any other part of GWW, you must be consistent in declaring the field names (Depth, Cl, etc.). These must be typed exactly the same as they are typed in Data Structure (in Chem_Conc_Depth_Tab).



*NOTE. The "depth" entry is protected. You cannot change the word or the way it is typed. GWW expects the word **Depth** which it uses internally.*

Using the command **Standard ASCII Input** you can import data tables created with a text processor or a spreadsheet program. (If you use spreadsheets, you must print such tables to a file. Spreadsheet program creates normally ASCII files, which then can be directly imported into GWW.)

Using the command **Standard ASCII Output** you are saving the data tables in ASCII format, such as the one shown above.

- 19.3.5. Depth Units** The units for depth are normally specified in Data Structure, in internal file *Chem_Conc_Depth_Tab*. However, you may change the units from within the application, using the command **Depth Units**.

19.4. LOG DESIGN MENU

On this menu you have five options:

- New Log Design
- Old Log Design
- Edit Log Design
- Save Log Design
- Save Log Design As

After you have created data table you will want to display graphs showing how concentration of one or more constituents changes with depth. Before you can display a graph, you need to create, modify or edit the design of such presentation. In GWW terminology, we use Log Design, implying that this is a vertical presentation of chemistry with depth.

- 19.4.1. New Log Design** When you select **New Log Design** GWW opens a dialogue box as shown in Figure 19-9. Some of components in this dialogue apply to the general layout of the display, such as Heading height and column axis height, fonts to be used on the graph, units for depth and level, and scale of the graph. The right side of the dialogue lists all available constituents (taken from Data Structure or from the internal file *Chem_Conc_Depth_Tab*). You may select one or more constituents to display, and by clicking on the button **Attributes** control how each constituent will be presented.

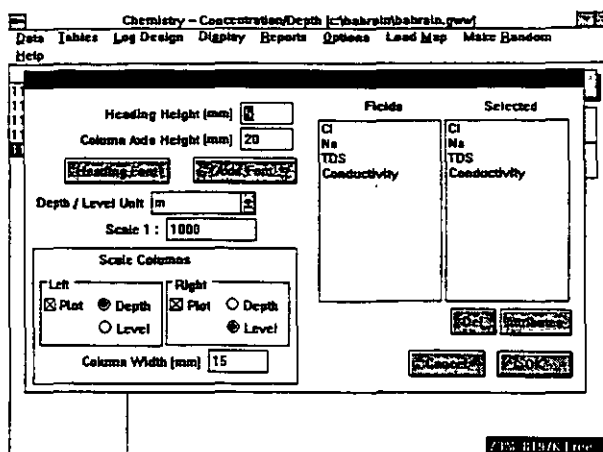

Figure 19-9

You are selecting or unselecting a constituent by highlighting it. If you highlight a constituent on the left side, that is within "Fields" part of the box, such constituent will be moved to the "Selected" side. If you highlight a constituent on the "Selected" side and press the button Del, this constituent will be deselected and will disappear from the list of selected constituents.

Below is explanation for each of options in this dialogue box.

Del ... Removes a constituent from the "Selected" field. Highlight the constituent you do not wish to display and press Del.

Heading Height ... Using this option you may change the height of the header row, with names of constituents, and words Depth and Label. The values are in millimeters.

Column Axis Height ... Using this option you select the size of the row in which individual concentration values are displayed.

Heading Font ... You may select fonts (family and size) for the header row.

Axis Font ... You may also control the font you are going to use for displaying individual values of constituents.

Depth/Level Unit ... Although the unit is preselected by you in Data Structure (the unit for depth), you may override your selection using this option.

Scale ... Depending on the depth you are going to present and the paper you will use to print the graph, you may change the scale.

Column Width ... The width you type here refers to the width of vertical columns in which Depth and Level values are displayed. The default is 15 mm.

Plot ... The graph is designed to plot either Depth or Level axes on the left and the right. You may control whether you wish to plot one, both, or none (?) ordinate axes, and where you will place the depth or level axis, to the left or to the right side of the graph.

19.4.2. Attributes

When you select a constituent or a chemical diagram parameter, you may control the way in which this particular constituent or parameter will be displayed. You will use the button **Attributes**. The dialogue box as shown in Figure 19-10 will be opened.

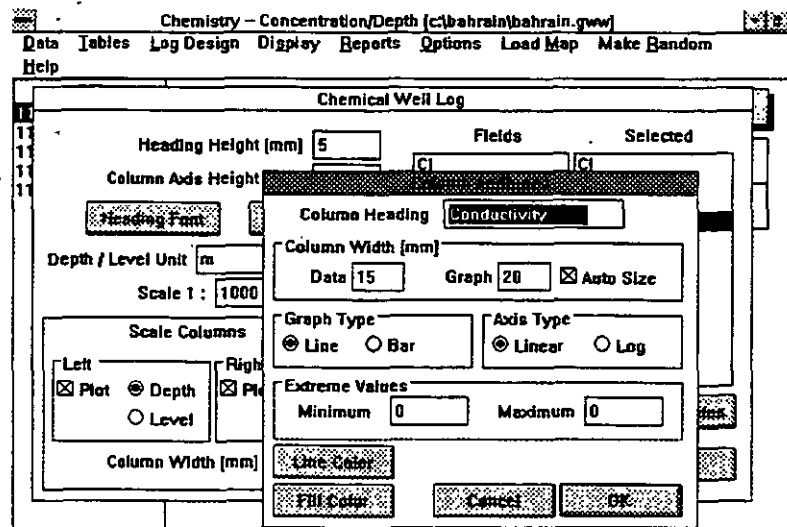

Figure 19-10

The entry "Column Heading" will offer the name of the constituent as found in the internal file Chem_Conc_Depth_Tab. However, you may override this offer and type a different name (e.g. in another language).

The options for column and graph width allow you to increase or reduce the size of vertical columns in which data (concentrations of a constituent) and graph (its graphical presentation) are displayed. While you may select the width for data, you are advised to keep the box **Auto Size** checked. GWW will then automatically select the size for the column in which the graph is displayed.

The **Graph Type** option allows you to select either line or bar graph. The **Axis Type** option allows you to display data as linear or logarithmic series. The **Extreme Values** (minimum and maximum) option lets you select the range of concentration you wish to display.

For each constituent you may select color for lines and for fills.

19.4.3. Old Log Design

Since you may create one or more designs for displaying various constituents and save them by assigning names, you may also retrieve and use one of pre-created designs. When you select the option **Old Log Design**, the list of all available designs will be listed, as shown in Figure 19-11.

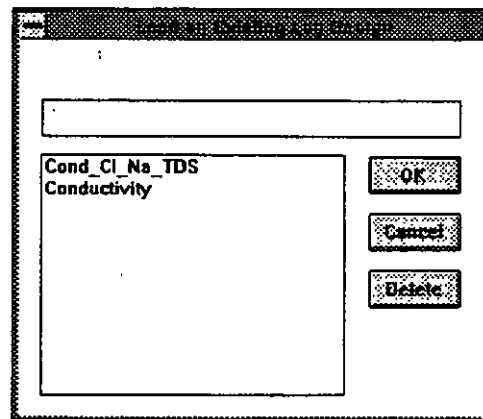

Figure 19-11

19.4.4. Save Log Design and Save Log Design As

When you finish editing an existing log design, you may save it under the name it was opened. GWW will not prompt you for a name. It will assume you want to use the old name.

You may save a design under a different name. For this you will use the option **Save Log Design As**.

19.4.5. Edit Log Design

The same dialogue box as the one shown in Figure 19-9 will be displayed and you may proceed with its editing in the same way in which you have created a new design.

19.5. DISPLAY

Figure 19-12 displays a graph with conductivity as the only parameter selected. Figure 19-13 displays a graph with four different constituents and/or parameters.

19.6. REPORTS

You may print a depth-concentration graph using the option **Report** from the application's menu bar. As shown in Figure 19-14 you will have to select between two reporting options:

- **Print Graph**
- **Print Table**

The option **Print Graph** will print the graph of the sample currently selected. The option **Print Table** will print information, in a tabular form, for all wells/samples that comprise the current working set. The information which will be printed will depend on what you have declared in the report form. When you select to print using one of options in the upper two lines of the menu, the program will prompt you to select a reporting form.

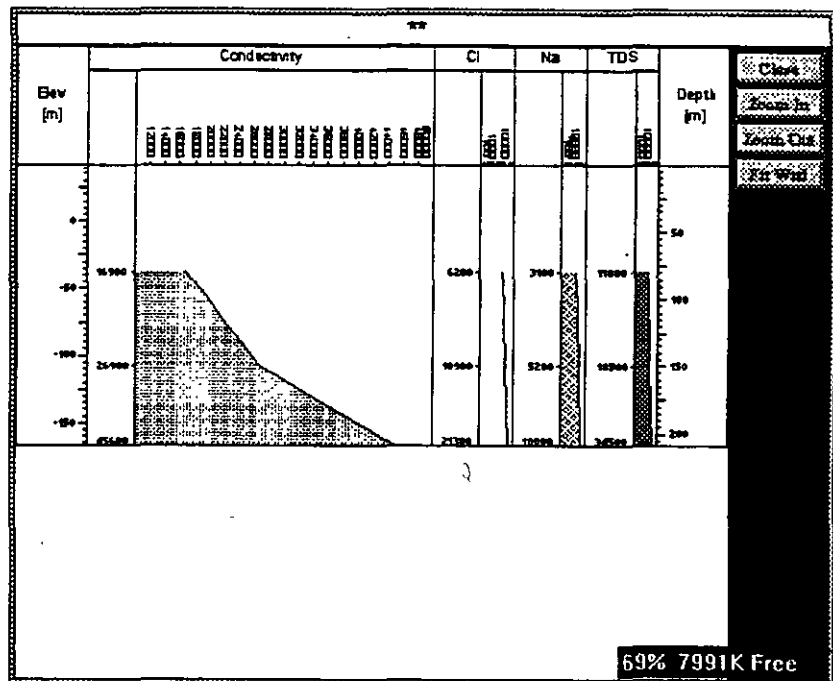
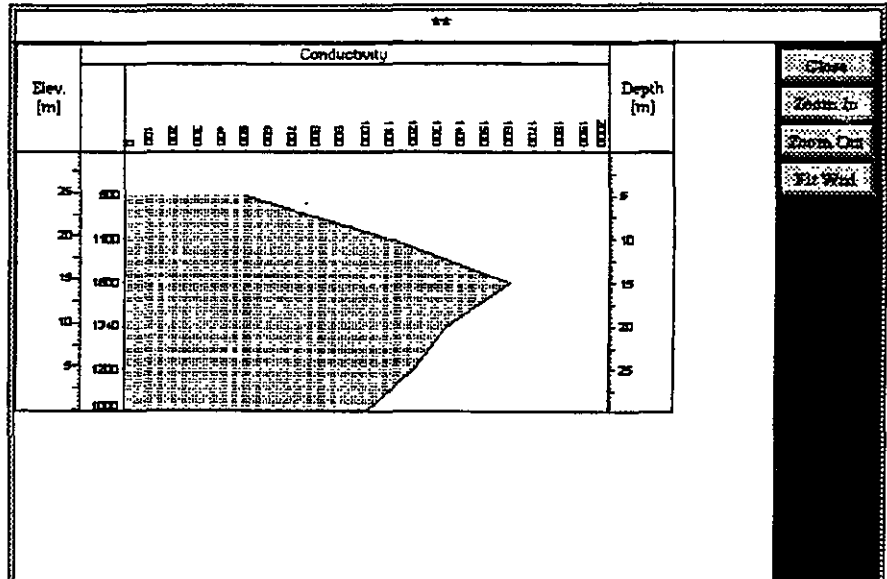

Figure 19-13

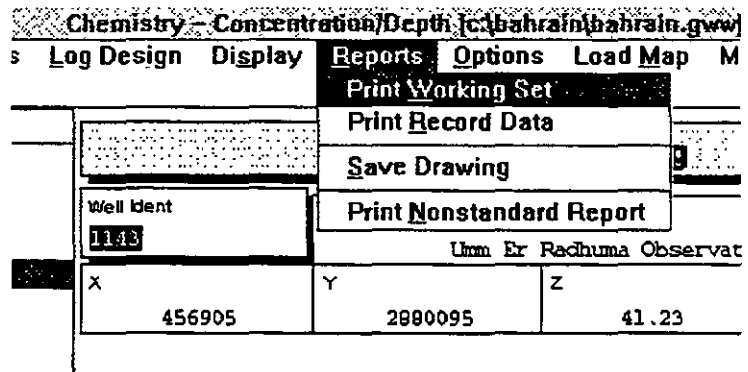

Figure 19-14

You may also save a depth-concentration graph for placing it on a nonstandard reporting form, eventually mixed with other graphics. For this, you use **Save Drawing** option, followed by **Print Nonstandard Report** from this or another application.

19.7. OPTIONS

Using this command, you may switch between parts per million (PPM) and equivalents per million (EPM). This is important in two instances. The first is the way in which constituents will be displayed. If you select EPM, the values displayed will be converted to equivalents per million, and vice versa. This option is also important to correctly import data tables as ASCII files. Depending on whether the data are prepared as ppm or epm, you need, prior to importing ASCII files, select the compatible mode of input. So, if your data have been prepared as ppm, you may use the default which is ppm. However, if the data have been prepared as epm, you should follow the sequence:

1. Select Options and select Show EPM values.
2. Select Table and select Standard ASCII Input.

19.8. MAP

The **Load Map** option is a general option for selecting wells to make a **Working Set** of wells.

19.8.1. Select Working Set from Map

The sequence is normally:

1. Click on **Data** to open the menu.
2. Click on **Select Working Set** and Unselect all wells. This is important because any selection adds new wells to the existing working set.
3. Click on **Map** to open the menu. Wait for the dialogue box to list available maps.
4. Select one of maps listed.
5. Select wells to make a working set using either **Rectangle**, **Points**, or **Area**. In the case of **Points**, use other buttons on the right side to complete the selection (**End Points**). In the case of an **Area**, after you circle an area (remember, in clockwise direction you are selecting within the area; in the counterclockwise direction outside the area!) you should close the area (**End Point**) followed by End Digitizing button. The wells (samples) will be listed in the left-side identification window.

19.9. To Setup a Printer

Selection of printers and attributes related to printing is normally a Windows operation. You may set up your printer parameters from Windows, prior to running the GWW program. To do this:

1. From **Main Group** select **Control Panel**.

2. Select **Printers**.
3. Select one of installed printers as a default printer, or add some more printers to match your hardware.
4. Select **Setup** and modify whatever you want to modify.
5. Click on **Set as default**.
6. Close **Printers and Control Panel**.

You may do about the same from inside the GWW. From within the GWW you use **Printer Setup** to change the orientation of printout, portrait (vertical) or landscape (horizontal), the printing medium, the quality of print, number of copies, colors for a color printer, and many more. You cannot change the default printer!

The dialogue box for selecting printer parameters is shown in Figure 19-15 for Hewlett Packard Laserjet 4/4M printer.

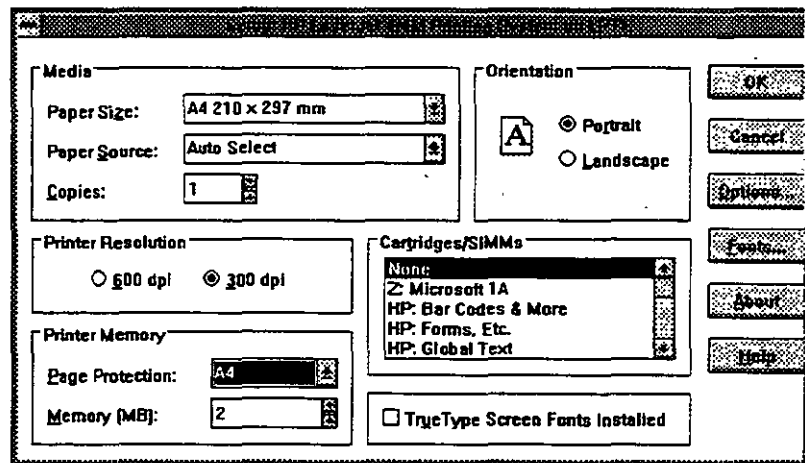

Figure 19-15



EXAMPLE

In the following example you will create data structure, use the default entry form supplied by GWW, and enter data with the following depth-dependent constituents: toluene, phenol, and benzene.

The data to input are the following:

Depth	Toluene	Phenol	Benzene
5	0	0	0
10	50	25	125
15	100	65	120
20	1000	75	70
25	155	25	0
30	0	0	0

Since the range of toluene is from 0 to 1000, you may select to display toluene in logarithmic scale, and the other two linearly.

1. To start with, from the GWW Main menu you will click on **Tools**, followed by **Data Structure Design**.
2. Wait until the new menu bar is displayed. Select **File**, then **Old**. Locate the internal file titled **Chem_Conc_Depth_Tab**.
3. Notice that there is only one entry, **Depth**. If you are working in feet system, you may want to replace the default unit for length, which is meter for foot.



4. Select **New**. Type **Toluene**. Use **TAB** to move to next field. Accept the default width of the field as 10 characters. Move down the dialogue box and check **Numeric** (do not check on **Numeric dimensioned** since the concentration of a chemical is a nondimensioned number!). Click on **OK**. In the next dialogue box select **OK** accepting all defaults (2 decimal digits, fixed point arithmetics). Notice that **Toluene** is displayed in the list of constituents.
5. Repeat the same for **Phenol**.
6. Repeat the same for **Benzene**. The list should now contain 4 parameters as shown in Figure 19-16.

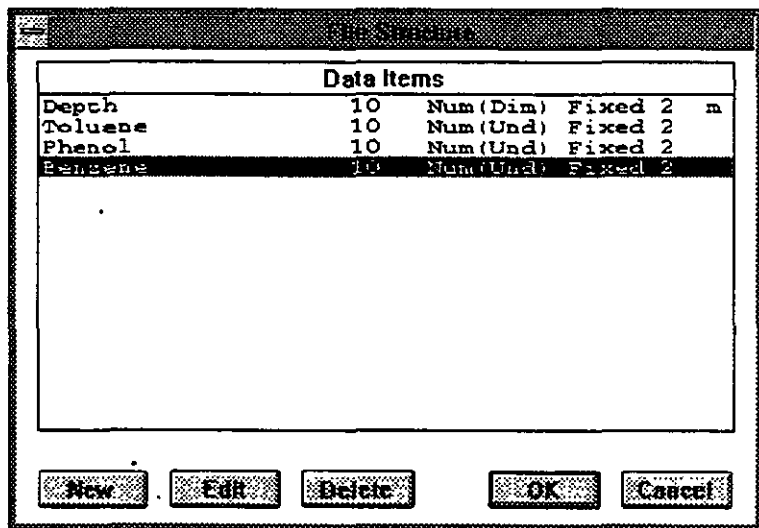

Figure 19-16

7. Close the dialogue box by selecting **OK**, select **File** and **Exit**. The new data structure for depth-concentration is created.
8. Click on **Applications** on the **GW** Main menu, then on **Chemistry**, and then on **Concentration - Depth**.
9. **GW** will display an entry form which will have only one field, **Well Identification**. The cursor will be in this field.
10. Type the well number, say **MW-1**. Now finish the input by pressing **Page Down** key once to complete the



entry, and second time to highlight this well and make it active. Alternatively select this well using the mouse.

11. Select Tables and click on Edit table. The display will be as shown in Figure 19-17. There will be four columns (Depth, Toluene, Phenol, Benzene), each with

MW-1 Chemical Constituents			
Depth[m]	Toluene	Phenol	Benzene
0.00	0.00	0.00	0.00

Figure 19-17

a 0.00 value. Fill in the values as prepared for this example. The table will look as shown in Figure 19-18.

12. When you finish typing, leave the cursor in the last typed row, that is depth 30, in the fourth column, and

MW-1 Chemical Constituents			
Depth[m]	Toluene	Phenol	Benzene
5.00	0.00	0.00	0.00
10.00	50.00	25.00	125.00
15.00	100.00	65.00	120.00
20.00	1000.00	75.00	70.00
25.00	155.00	25.00	0.00
30.00	0.00	0.00	0.00

Figure 19-18

press the combination Ctrl S. (Alternatively, you may click on Tables, and then on Save.)

13. Now you will create your own log design. Select Log Design on the menu bar. Select New Log Design. The screen will display the three constituents as "selected fields", as shown in Figure 19-19.

14. Change the scale from the default 1000 to 500. Click on OK.

15. Now you may see immediately the graph. Click on Display. The default parameters are used to display



Figure 19-19

this graph. The display is as shown in Figure 19-20. Click on the button Close to remove this graph.

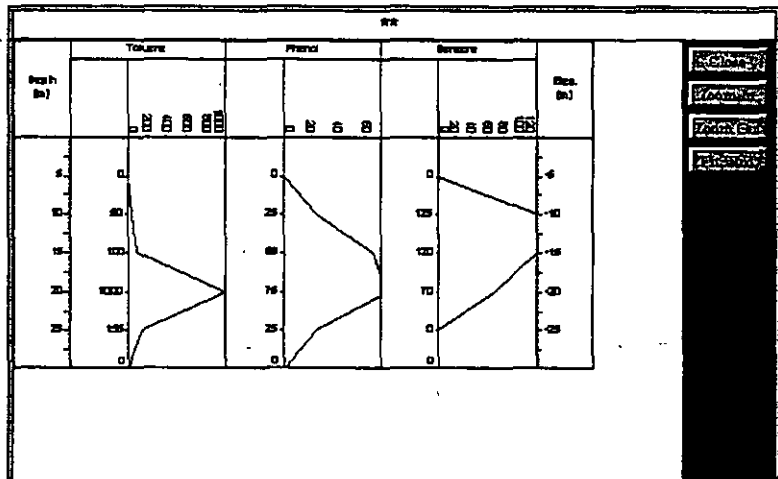

Figure 19-20

16. Modify the graph design. Select **Log Design**, then **Edit Log Design**. Click on Toluene on the right side of the dialogue box. The constituent Toluene will be highlighted. Now click on the button **Attributes**. In the new dialogue box check the field **Logarithmic**, and in the boxes **Minimum** and **Maximum** type 0.1 and 1000, respectively. Click also on **Fill color** and select a color. Click on **OK** to close the **Attributes** dialogue. Now replace the word Toluene in **Column Heading** box with **TOLUENE ppb**. Click also on **Heading Font**, and select for font **Arial 12 points, bold**. Click on **OK** to close the font dialogue box, and then **OK** to close the log design editing box.
17. Select **Display** again. The screen looks as shown in Figure 19-21. Save this log design. Close the display.

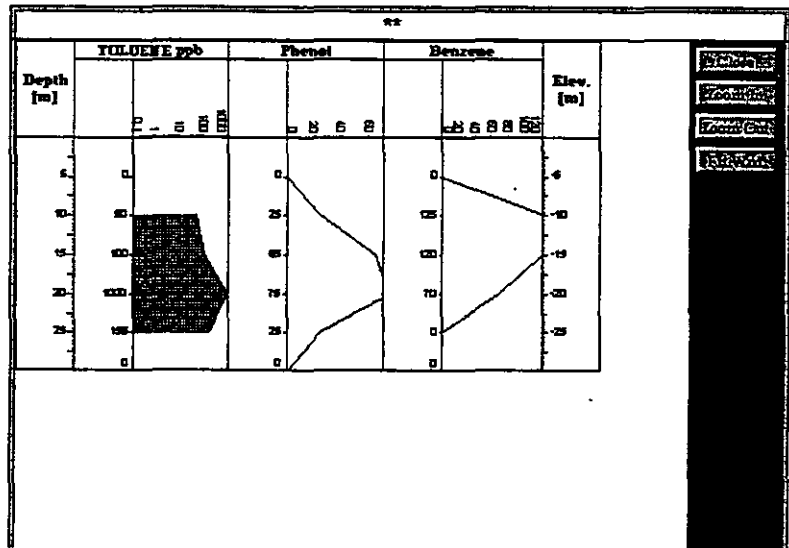

Figure 19-21

Select **Log design**, followed by **Save Log Design**. Type a name for this design.

18. The task now is to have only toluene displayed and/or printed. Select **Log Design**, then **Edit Log Design**. Highlight phenol and click on **Del**. Repeat the same with benzene. Only toluene remains in the

"selected" list. Highlight Toluene and click on Attributes. Notice that the width of the graph field is still 25 mm. Click on OK and then repeat highlighting Toluene and selecting Attributes. Notice now that the width of graph is 105 mm. This is automatically calculated, since there will be only one graphic field. Click on OK and select Display. The display is as shown in Figure 19-22.

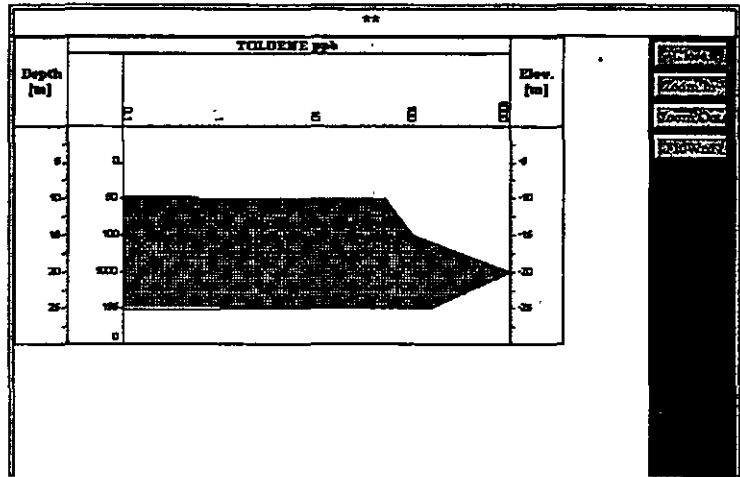

Figure 19-22

19. Close the display, exit the application, and exit GWW.

This ends this example.

This page intentionally left blank.

20.1 INTRODUCTION**20.1.1. General**

Using this application you may create a data base with various chemical constituents related to the time of sampling. This is especially important in cases when the sampling is repeated over a period of time, which is often the case in monitoring the propagation of contamination, or deterioration of ground water quality with time. Likewise in saline water environments such as in coastal aquifers, the sea water intrusion may take place after a prolonged pumping.

The data base is in a form of individual tables, one for a well, plus some general information that may also be a part of the data base. The display is user-designable. You decide whether you wish to display one or more constituents on the same diagram, and whether the scale will be linear or logarithmic. You may display one or more constituents as linear graphs, and another as logarithmic. That is, each constituent may be assigned its own attributes for presentation.

As in other parts of GWW, you may create graphs and save them for later printing.

This application is a part of the Chemistry application. Actually it branches off from Chemistry as shown in Figure 20-1. To activate it, you should select Applications, then Chemistry, and then Concentration-Time.

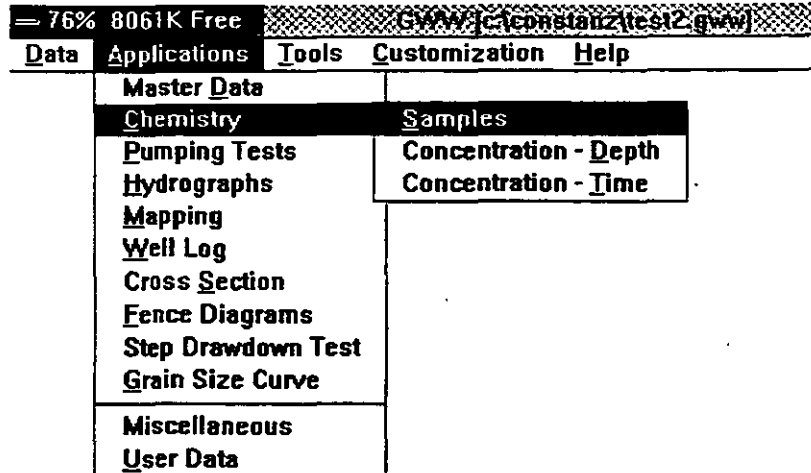

Figure 20-1

20.1.2. Application's Content As shown in Figure 20-2, the Concentration-Time application is comprised of the following major options:

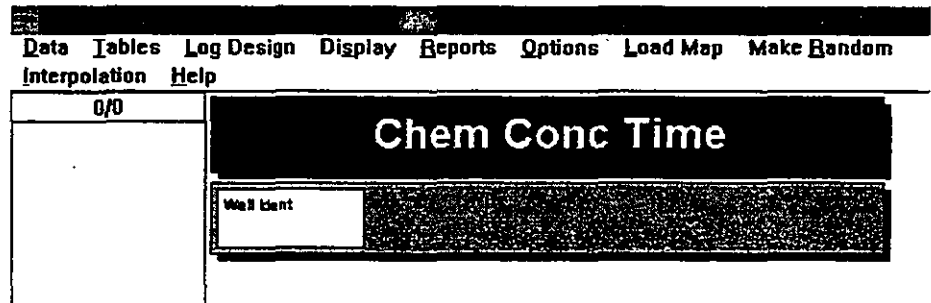

Figure 20-2

- Data
- Tables
- Log Design
- Display
- Reports
- Options

- Load Map
- Make Random
- Interpolation
- Help

Prior to using this application you must modify the file structure for "concentration - time series" to make it compatible with the parameters that you wish to store, display, and retrieve as reports.

From the Main menu on GWW, you should select **Tools**, followed by **Data Structure Design**. This activates the file structure editor. Select **Files**, followed by **Old**. From the list of internal data structures select the one labeled as *Chem_Conc_Time_Tab*. In the default template, GWW.000, which comes on the distribution diskette, the only entry that is prepared is **Date**. Using the editor create your own list of chemical constituents that you wish to store in the data base. One of such lists is shown below.

Date	10	Date	mm/dd/yy
Cl	10	Num(Und)	Fixed 2
Na	10	Num(Und)	Fixed 2
TDS	10	Num(Und)	Fixed 1
Conductivity	10	Num(Und)	Float 1

As it is prepared, one may store, display and report data on chloride, sodium, total dissolved solids, and on conductivity of water.

The **Data** menu is shown in Figure 20-3. In this menu you select your current working set (reduce a large set to a smaller, thematic set). You may

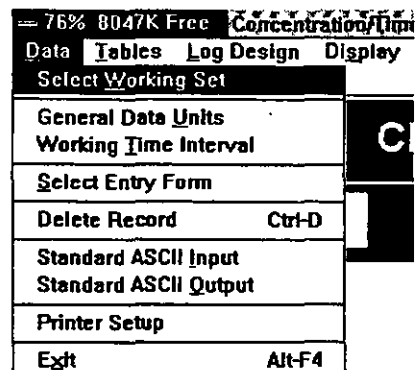

Figure 20-3

check which units are currently used for general data (sampled well coordinates and elevations). You may select one of entry forms that you may have eventually created. You may also delete a record. You may read general data on sampled wells (coordinates, elevations, descriptions, names, etc.) from an ASCII file, or you may save such data to an ASCII file. This menu deals with wells and not with tables. A table is the place in which you type chemical constituents as a function of time. This latter is done using the menu Tables. On this submenu you will select the Time Interval in which you wish to display the data. That is to say, you may create a data base spanning a very large time period. However, when you wish to display or print the data, you may select a smaller time interval to emphasize the time-dependent values.

The Tables menu is shown in Figure 20-4. Using this menu you either type your data, edit table, add or re-

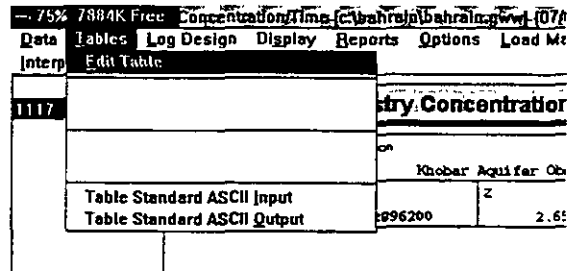

Figure 20-4

move some rows in the table, save data, and exit (close) table. Just the same as in other applications, you may save your tables (time-concentration data) and/or import them as ASCII files.



NOTE. One table is saved in one ASCII file.

The Log Design menu is shown in Figure 20-5. The commands on this menu are used to customize the display and printout. The customization means, first, which constituents from a table you wish to display. For example,

Chemistry Concentration Time Constants GWW			
Data Tables	Log Design	Display	Reports Options Load
Interpolation	New Log Design		
22/22	Old Log Design		
CT149102	Edit Log Design	tanza	Chemistry C
CT158901	Save Log Design		
CT159001	Save Log Design As...		
CT159201			
CT168901			
CT169103			
CT178903			
CT178904			

Figure 20-5

although you may have entered the values for Na, Cl, TDS, and conductivity, you may decide to display and/or report only total dissolved solids. Second, you may assign some attributes to the constituents to be displayed: line and fill color, linear or logarithmic display, minimum and maximum concentrations to display, etc. You may also control widths of individual columns used to display constituents.



NOTE. The control of fonts used to label a graph is accomplished from Customization, which is one of commands on the Main menu of GWW.

On this current menu you design a "display" log, you edit it, save it, or select one of available designs.

The command **Display** does not have any other sub-commands. It does what it says. It displays a graph with data from table connected to a currently highlighted sample, using the design for the graph as currently selected.

The **Reports** menu is shown in Figure 20-6. Using the commands on this menu, you may print a graph, or save it for future printing, or mixing with other graphs.

The **Options** menu allows you to switch between parts per million (PPM) and equivalents per million (EPM). Of course, this will apply only to charged ionic constituents

Chemistry - Concentration/Time (constant) (cons-gww) 10			
Tables	Log Design	Display	Reports Options Load
Interpolation	Help		Print Working Set
22/22			Print Record Data
19102	Valle de Co		Save Drawing
58901	Well bent		Print Nonstandard Report
59001	589102		
59201			
58901	X	Y	Z
59103	314780	2091770	11:
78903			
78904			

Figure 20-6

for which conversion factors are available in the auxiliary file PPMTOEPM.TBL.

The Map menu is explained in Chapter 5, Section 5.3.2. It is used to load a map and select sampled points directly from the map.

The Make Random menu is also explained in details in Chapter 5, Section 5.6. It will be used for creating location or site maps showing sampling points at which time-variable chemical data are available.

20.2. DATA MENU

The routines on this menu are equivalent to similar routines in other applications. See, for example, Hydrographs application, especially for selecting the Working Time Interval.



NOTE. Remember that the currently selected Working Time Interval is displayed in the title bar next to the name of the data base file.

20.3. TABLES MENU

Using the commands on this menu you are creating your data base as it refers to concentration of selected constituents with time. You may import an already created table as an ASCII file, one for a sample, or you may use the GWW editor.

- 20.3.1. Edit Table** When you select the **Edit Table** command for a new sample, the editor displays an empty table listing all constituents that you have listed in the Data Structure on the Tools menu. In the case when only three constituents are selected (say, EC, NO3, and NO2), the table may look as shown in Figure 20-7. If you are going to edit an existing table filled with data, the display may look as shown in Figure 20-8.

MW-1 Chemical Constituents						
Year	Month	Day	Time	EC	NO3	NO2

Figure 20-7

CT149102 Chemical Constituents						
Year	Month	Day	Time	EC	NO3	NO2
1992	3	1	12:0	764	0	0
1993	4	1	12:0	890	189.2	0.02
1994	2	1	12:0	905	50.61	0.05

Figure 20-8

To edit data, you use standard GWW commands: TAB to move from one field to next, Shift+TAB to move backwards, CTRL+I to insert a line, CTRL+D to delete a line. The program checks the sequence of time entries. You are expected to use the logical sequence, from early time to later.

20.3.2. Save Data When you finish typing the data you will save them using one of two ways. The first is to press the Ctrl key and simultaneously press the S key. The other way is to use the mouse and click on **Tables** on the menu bar and click again on **Save Data**.

20.3.3. Exit without saving You may have decided only to view the data without saving them. When you are done with viewing the data, you may exit in one of the two ways. The first is to press the Ctrl key and simultaneously press the X key. The other way is to use the mouse and click on **Tables** on the menu bar and click again on **Exit (Don't save)**.

20.3.4. Standard ASCII Input and Output The data tables can be created outside the GWW package using a text processor. The format is similar to the format in other applications. One such table is reproduced below.

```
<yyyy/mm/dd> <Cl> <Na> <Conductivity>
1983/04/25 500.0 200.0 2200.0 2650.0
1983/06/22 750.0 340.0 3300.0 4010.0
1983/08/04 468.0 188.0 2100.0 2550.0
```

The first line is the header line which tells GWW what are the numbers that follow. As in any other part of GWW, you must be consistent in declaring the field names (time, Cl, etc.). These must be typed exactly the same as they are typed in Data Structure (in Chem_Conc_Time_Tab). The first entry is the date and time. You supply the format of data input (yyyy/mm/dd), which you must follow in the data below the header line. You may reverse the order of "date" input to one of date formats that are acceptable in GWW.

The date/time format can be any of the following: yy/mm/dd, yyyy/mm/dd, -mm-yy, .mm.yy, etc. It is important that the data that follow the header line must be typed according to the format declared in the header.

Using the command Standard ASCII Input you can import data tables created with a text processor or a spreadsheet program. (If you use spreadsheets, you must print such tables to a file. Any spreadsheet program, when instructed, creates normally ASCII files, which then can be directly imported into GWW.)

Using the command Standard ASCII Output you are saving the data tables in ASCII format, such as the one shown above.

20.4. LOG DESIGN MENU

On this menu you have five options:

- New Log Design
- Old Log Design
- Edit Log Design
- Save Log Design
- Save Log Design As

After you have created data table you will want to display graphs showing how concentration of one or more constituents changes with time. Before you can display a graph, you need to create, modify or edit the design of such presentation. The "Log Design" is used in other parts of GWW implying a vertical presentation of data. Here, it implies a "diagram" design of chemical data presentation with time.

20.4.1. New Log Design

When you select New Log Design GWW opens a dialogue box as shown in Figure 20-9. The right side of the

dialogue lists all available constituents (taken from Data Structure or from the internal file Chem_Conc_Time_Tab). You may select one or more constituents to display, and by clicking on the button **Attributes** control how each constituent will be presented.

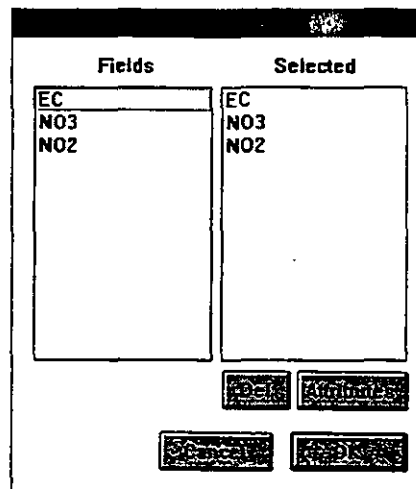

Figure 20-9

You are selecting or unselecting a constituent by highlighting it. If you highlight a constituent on the left side, that is within "Fields" part of the box, such constituent will be moved to the "Selected" side. If you highlight a constituent on the "Selected" side and press the button **Del**, this constituent will be deselected and will disappear from the list of selected constituents.

20.4.2. Attributes

When you select a constituent or a chemical diagram parameter, you may control the way in which this particular constituent or parameter will be displayed. You will use the button **Attributes**. The dialogue box as shown in Figure 20-10 will be opened.

The entry "Column Heading" will offer the name of the constituent as found in the internal file Chem_Conc_Time_Tab. However, you may override this

offer and type a different name (e.g. in another language).

Figure 20-10

The options for column and graph width allow you to increase or reduce the size of vertical columns in which data (concentrations of a constituent) and graph (its graphical presentation) are displayed. While you may select the width for data, you are advised to keep the box **Auto Size** checked. GWW will then automatically select the size for the column in which the graph is displayed.

The **Axis Type** option allows you to display data as linear or logarithmic series. The **Extreme Values** (minimum and maximum) option lets you select the range of concentration you wish to display.

For each constituent you may select color for lines and for fills.

20.4.3. Old Log Design

Since you may create one or more designs for displaying various constituents and save them by assigning names, you may also retrieve and use one of pre-created designs. When you select the option **Old Log Design**, the

list of all available designs will be listed, as shown in Figure 20-11.

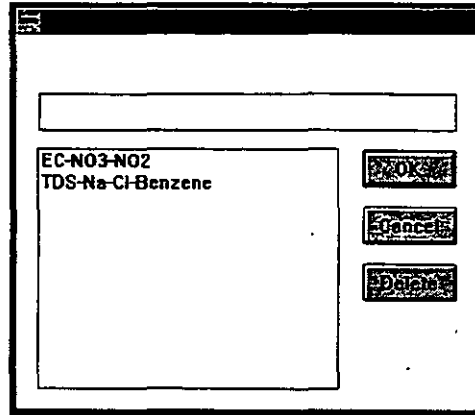

Figure 20-11

20.4.4. Save Log Design and Save Log Design As

When you finish editing an existing log design, you may save it under the name it was opened. GWW will not prompt you for a name. It will assume you want to use the old name.

You may save a design under a different name. For this you will use the option **Save Log Design As**.

20.4.5. Edit Log Design

The same dialogue box as the shown in Figure 20-9 will be displayed and you may proceed with its editing in the same way in which you have created a new design.

20.5. DISPLAY

Figure 20-12 displays a graph with conductivity as the only parameter selected. Figure 20-13 displays a graph with three different constituents and/or parameters.

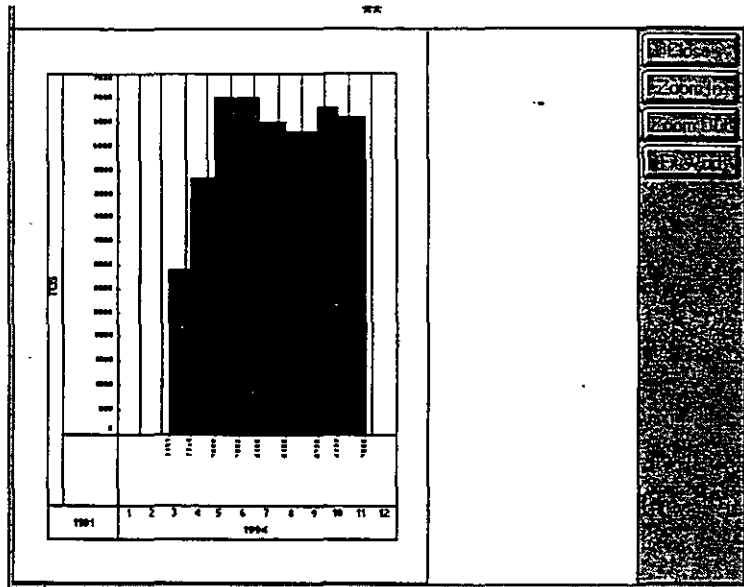

Figure 20-12

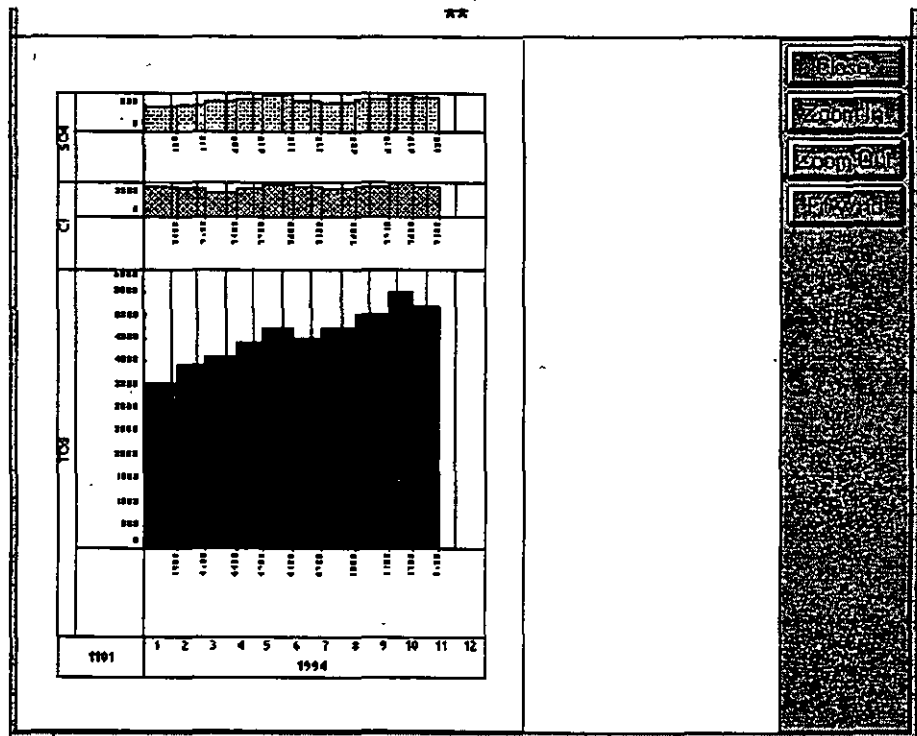

Figure 20-13



NOTE. When you select the option Interpolation/Set Connection Span and type a relatively small number of days, the samples that are taken beyond the span selected (that is, at greater intervals than specified) will be shown as vertical bars.

20.6. REPORTS

You may print a time-concentration graph using the option **Report** from the application's menu bar. As shown in Figure 20-14 you will have to select between two reporting options:

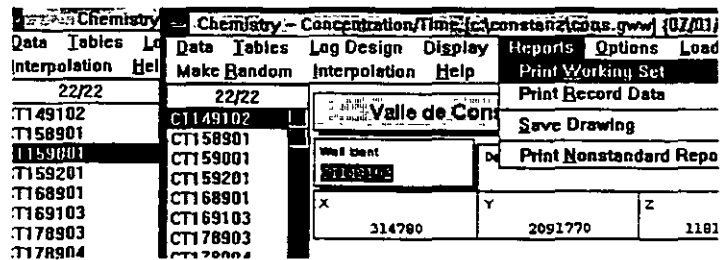

Figure 20-14

- Print Working Set
- Print Record Data

The option **Print Drawing** will print the graph of the sample currently selected. The option **Print Working Set** will print information, in a tabular form, for all wells/samples that comprise the current working set. The information which will be printed will depend on what you have declared in the report form. When you select to print using one of options in the upper two lines of the menu, the program will prompt you to select a reporting form.

You may also save a time-concentration graph for placing it on a nonstandard reporting form, eventually mixed with other graphics. For this, you use **Save Drawing** option, followed by **Print Nonstandard Report** from this or another application.

20.7. OPTIONS

Using this command, you may switch between parts per million (PPM) and equivalents per million (EPM). This is important in two instances. The first is the way in which constituents will be displayed. If you select EPM, the values displayed will be converted to equivalents per million, and vice versa. This option is also important to correctly import data tables as ASCII files. Depending on whether the data are prepared as ppm or epm, you need, prior to importing ASCII files, select the compatible mode of input. So, if your data have been prepared as ppm, you may use the default which is ppm. However, if the data have been prepared as epm, you should follow the sequence:

1. Select Options and select Show EPM values.
2. Select Table and select Standard ASCII Input.

20.8. LOAD MAP

The **Load Map** option is a general option for selecting wells to make a **Working Set** of wells.

20.8.1. Select Working Set from Map

The sequence is normally:

1. Click on **Data** to open the menu.
2. Click on **Select Working Set** and **Unselect** all wells. This is important because any selection adds new wells to the existing working set.
3. Click on **Load Map** to open the menu. Wait for the dialogue box to list available maps.
4. Select one of maps listed.
5. Select wells to make a working set using either **Rectangle**, **Points**, or **Area**. In the case of **Points**, use other buttons on the right side to complete the selection (**End Points**). In the case of an **Area**, after you circle an area (remember, in clockwise direction you are selecting within the area; in the counterclockwise direction outside the area!) you should close the area (**End Point**) followed by **End Digitizing** button. The wells (samples) will be listed in the left-side identification window.

20.9. To Setup a Printer

Selection of printers and attributes related to printing is normally a Windows operation. You may set up your printer parameters from Windows, prior to running the GWW program. To do this:

1. From **Main Group** select **Control Panel**.
2. Select **Printers**.
3. Select one of installed printers as a default printer, or add some more printers to match your hardware.
4. Select **Setup** and modify whatever you want to modify.
5. Click on **Set as default**.
6. Close **Printers** and **Control Panel**.

You may do about the same from inside the GWW. From within the GWW you use **Printer Setup** to change the orientation of printout, portrait (vertical) or landscape (horizontal), the printing medium, the quality of print, number of copies, colors for a color printer, and many more. You cannot change the default printer!

The dialogue box for selecting printer parameters is shown in Figure 20-15 for Hewlett Packard Laserjet 4/4M printer.

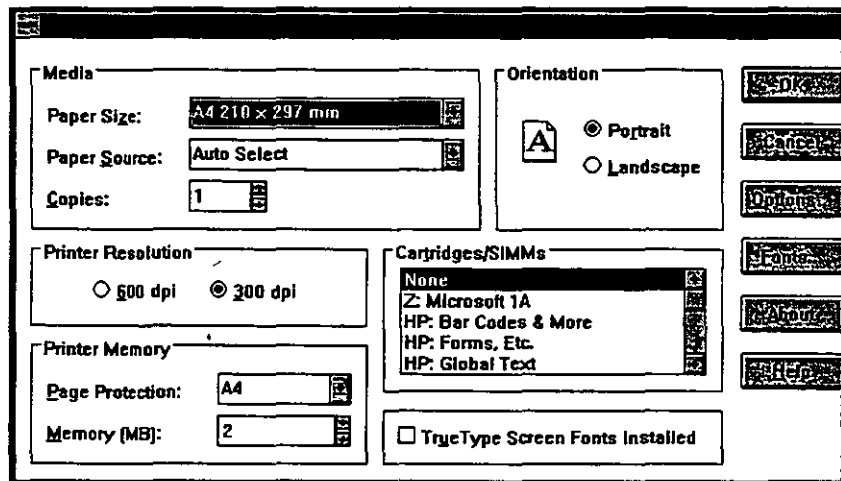

Figure 20-15

20.10. Interpolation

Same as in the Hydrographs application, you may create a random data file to be used to create a grid file and a contour map, for any chemical constituent at any time within the current Working Time Interval. You will select Interpolation on the menu bar. The display is as shown

in Figure 20-16. Select **Interpolate**. The dialogue box as shown in Figure 20-17 opens prompting you for the year, month, and day for which you wish GWW to interpolate

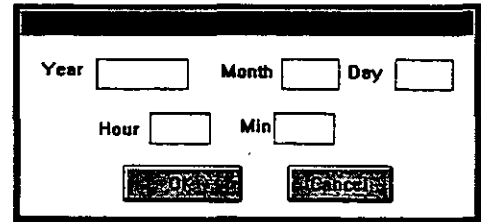
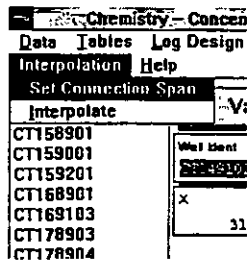

Figure 20-16

Figure 20-17

the data. Next you will be prompted to select one of available constituents, as shown in Figure 20-18, of which you wish to create a random file. (Remember that you need to have X and Y coordinates for all wells/samples in the data base. The random file consists of the following columns: X, Y, concentration at a certain date, well identification.)

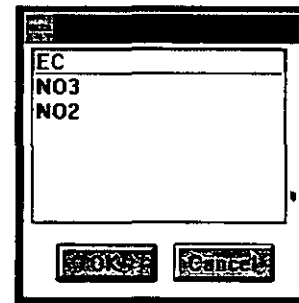

Figure 20-18

You may also select a "connection span", which is the maximum number of days that you allow to elapse if the two successive values are to be connected.



EXAMPLE

In the following example you will create data structure, use the default entry form supplied by GWW, and enter data with the following time-dependent constituents: Na, Cl, TDS, and Conductivity.

The data to input are the following (in the order after the date: Na, Cl, TDS, and Conductivity).

1984/05/01	100.0	250.0	2500.0	3000.0
1984/06/01	150.0	300.0	3500.0	4000.0
1984/07/01	250.0	400.0	5000.0	5368.0
1984/08/01	200.0	340.0	4500.0	4988.0
1984/10/01	250.0	410.0	5000.0	5800.0
1984/10/15	200.0	386.0	4500.0	5300.0

1. To start with, from the GWW Main menu you will click on **Tools**, followed by **Data Structure Design**.
2. Wait until the new menu bar is displayed. Select **File**, then **Old**. Locate the internal file titled **Chem_Conc_Time_Tab**.
3. Notice that there is only one entry, **Date**.
4. Select **New**. Type **Na**. Use **TAB** to move to the next field. Accept the default width of the field as 10 characters. Move down the dialogue box and check **Numeric** (do not check on **Numeric dimensioned** since concentration of a chemical is a nondimensioned number!). Click on **OK**. In the next dialogue box se-



lect OK accepting all defaults (2 decimal digits, fixed point arithmetics). Notice that Na is displayed in the list of constituents.

5. Repeat the same for Cl.
6. Repeat the same for TDS and for Conductivity, but select floating point for the data type, and decrease the number of decimal digits to 1. The list should now contain 5 parameters as shown in Figure 20-19.

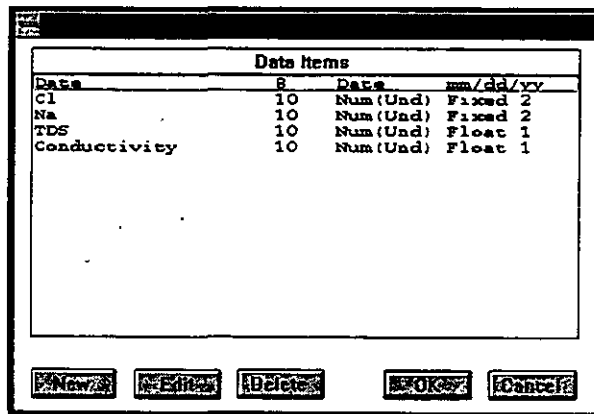

Figure 20-19

7. Close the dialogue box by selecting OK, select File and Exit. The new data structure for the time-concentration portion of the data base is created.
8. Click on Applications on the GWW Main menu, then on Chemistry, and then on Concentration - Time.
9. GWW will display an entry form which will have only one field, Well Identification. The cursor will be in this field.
10. Type the well number, say MW-1. Now finish the input by pressing Page Down key once to complete the entry, and second time to highlight this well and make it active. Alternatively select this well using the mouse.
11. Select Tables and click on Edit table. The display will be as shown in Figure 20-20. There will be five col-



MW-1 Chemical Constituents							
Year	Month	Day	hh:mm	Cl	Na	TDS	Con

Figure 20-20

umns (Time, Na, Cl, TDS, and Conductivity), each with an empty field. GWW automatically create an entry field for hour and minutes, which you may ignore. The noon time will be automatically assumed. Fill in the values as prepared for this example. The table will look as shown in Figure 20-21.

MW-1 Chemical Constituents							
Year	Month	Day	hh:mm	Cl	Na	TDS	Conductivity
1984	5	1	12:0	100	250	2500	30
1984	6	1	12:0	150	300	3500	40
1984	7	1	12:0	250	400	5000	53
1984	8	1	12:0	200	340	4500	49
1984	10	1	12:0	250	410	5000	58
1984	10	15	12:0	200	386	4500	53

Figure 20-21

12. When you finish typing, leave the cursor in the last typed row, and press the combination Ctrl S. (Alternatively, you may click on Tables, and then on Save.) If your time entries are not in sequence, GWW will beep on you, display a message Invalid Date/Time order!, and will place the cursor in the line that is out of the time sequence.

13. Now you will create your own log design. Select Log Design on the menu bar. Select New Log Design. The screen will display

four constituents as "selected fields", as shown in Figure 20-22. Since you will accept the

Fields	Selected
Cl	Cl
Na	Na
TDS	TDS
Conductivity	Conductivity

Figure 20-22



defaults, click on OK to close this dialogue box.

14. Now you may see immediately the graph. Click on Display. The default parameters are used to display this graph. The display is as shown in Figure 20-23.

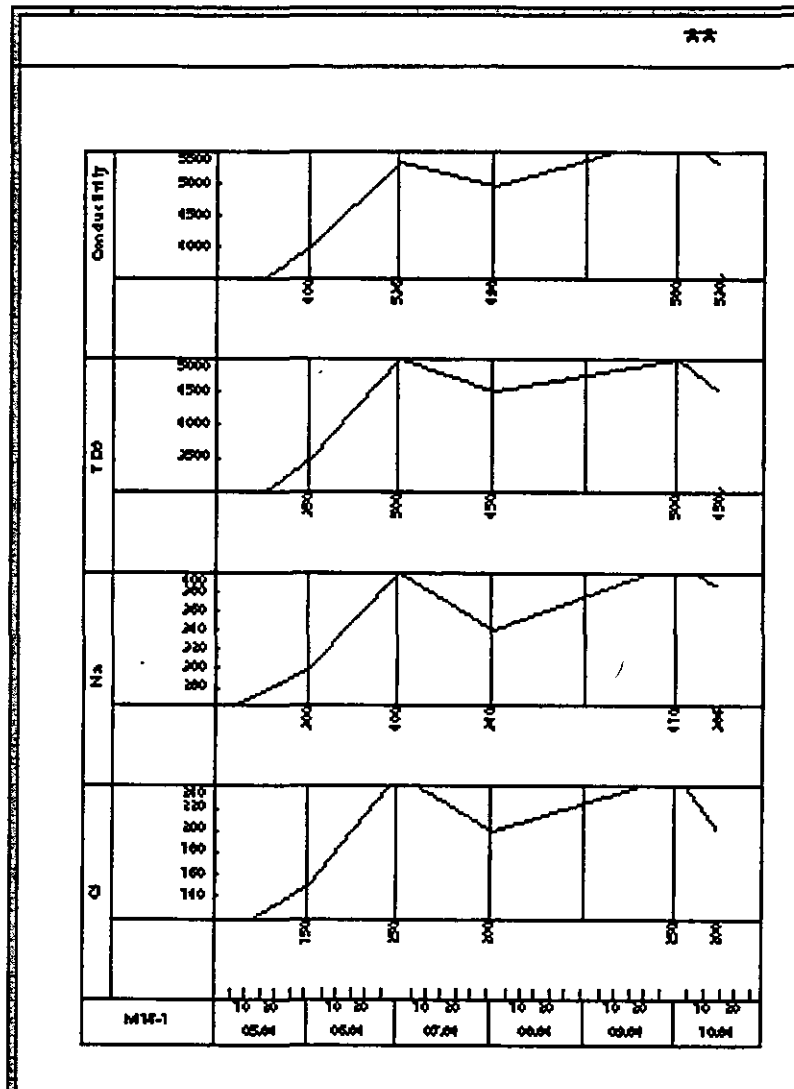

Figure 20-23



Click on the button Close to remove this graph.

15. Modify the graph design. Select **Log Design**, then **Edit Log Design**. Click on TDS on the right side of the dialogue box. The constituent TDS will be high-

lighted. Now click on the button **Attributes**. In the new dialogue box in boxes for Minimum and Maximum type 1000 and 5000, respectively. Click also on **Fill color** and select a color. Now replace the word **TDS** in **Column Heading** box with **TDS in ppm**. Click on **OK** to close the **Attributes** dialogue, and again on **OK** to close the **Log Design** dialogue.

16. Select **Display** again. The screen looks as shown in

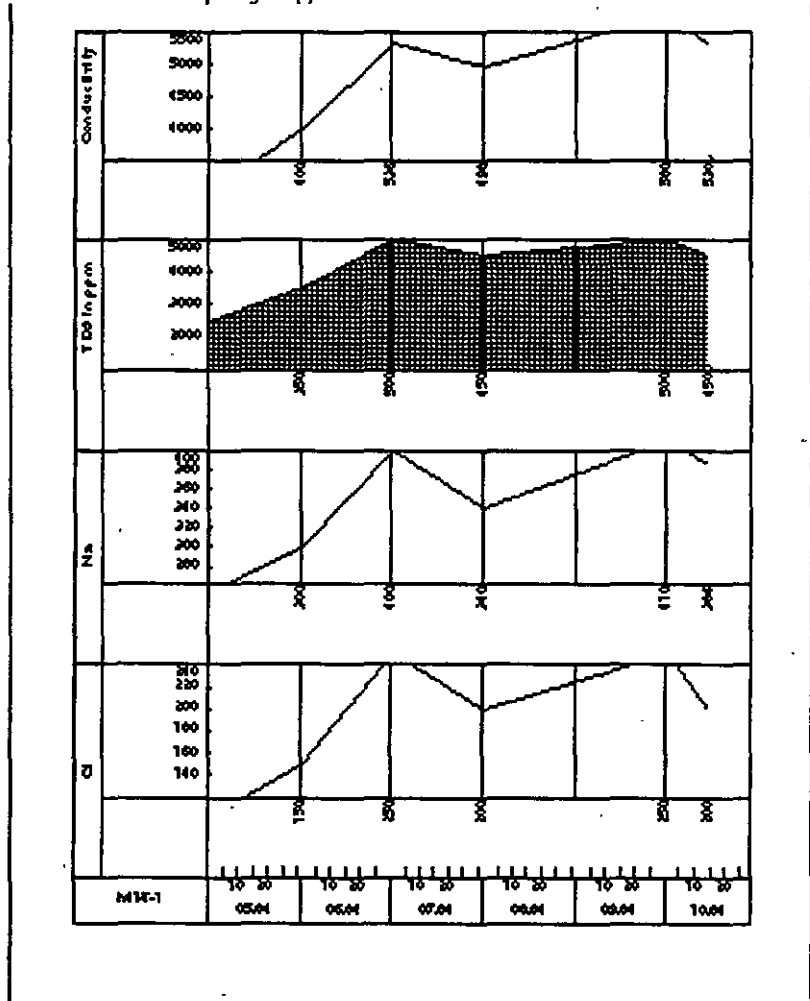

Figure 20-24



Figure 20-24. Save this log design. Close the display. Select **Log Design**, followed by **Save Log Design As**. Type a name for this design.

17. The task now is to have only TDS displayed and/or printed. Select **Log Design**, then **Edit Log Design**. Highlight **Na** and click on **Del**. Repeat the same with **Cl** and **Conductivity**. Only **TDS** remains in the "selected" list. Highlight **TDS** and click on **Attributes**. Notice that the width of the graph field is still 25 mm. Close this dialogue, close the log design editing dialogue, and display the graph by selecting **Display**.

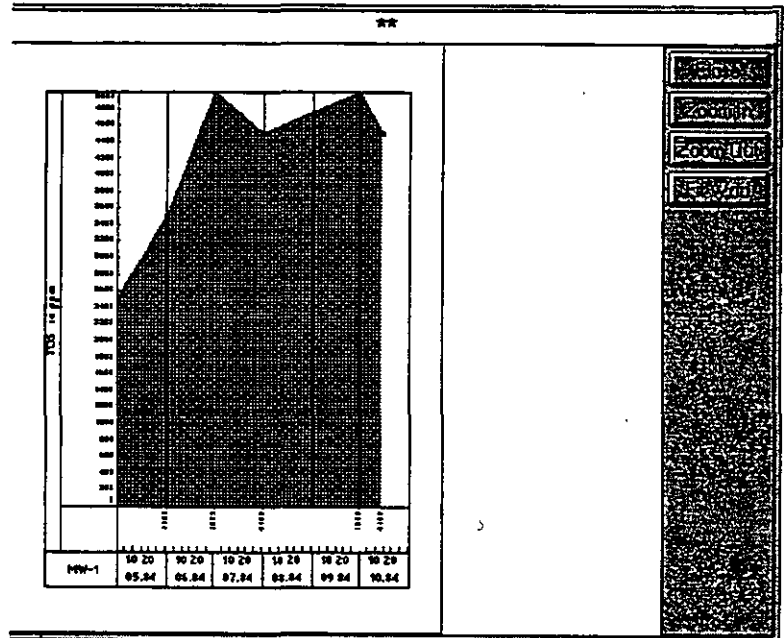

Figure 20-25

Notice that the TDS graph fills the whole screen. The display is shown in Figure 20-25. To check the width which is automatically selected because you left the



Auto Size box checked, close this display, and select Edit Log Design again. Highlight TDS, select Attributes, and notice the new size, something like 144 mm.

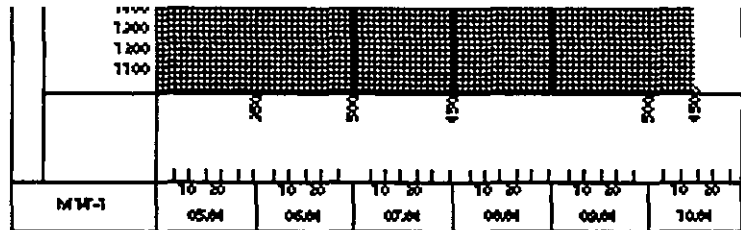

Figure 20-26

Figure 20-26 shows the zoomed time axis. This is the lower part of the drawing.

18.Exit the application, and exit GWW.

This ends this example.



This page intentionally left blank.

APPENDIX A ... GWW FILES

LIST OF FILES MAKING THE GWW FILE SYSTEM

The following files should be located in the \GWW directory after the installation.

(a) Executable Files (only GWW.EXE is directly executable; all other 'exe' files are called from GWW.EXE):

- GWW.EXE
- MASFILE.EXE
- FORMED.EXE
- EDFC.EXE
- UNITS.EXE
- CHEM.EXE
- CHEMT.EXE
- CHEMW.EXE
- HG.EXE
- LITH.EXE
- XSECT.EXE
- MAP.EXE
- PUMP.EXE
- MISC.EXE
- GSC.EXE
- SDDT.EXE
- UFILE.EXE
- XSMD.EXE

(b) Help Files:

- PUMP.HLP
- XSECT.HLP
- HYDRO.HLP
- FORMED.HLP
- GWW.HLP
- GSC.HLP
- SDDT.HLP
- EDFC.HLP
- CHEM.HLP
- CHEMT.HLP
- CHEMW.HLP
- UNT.HLP
- MAP.HLP
- MASTER.HLP
- LITH.HLP
- UFILE.HLP
- XSMOD.HLP
- MISC.HLP

(c) Various Auxilliary Files:

- PPMTOEPM.TBL
- SCREEN.DLT
- LITH.DLT
- ANNULUS.DLT

(d) GWW Data Base Template:

- GWW.000

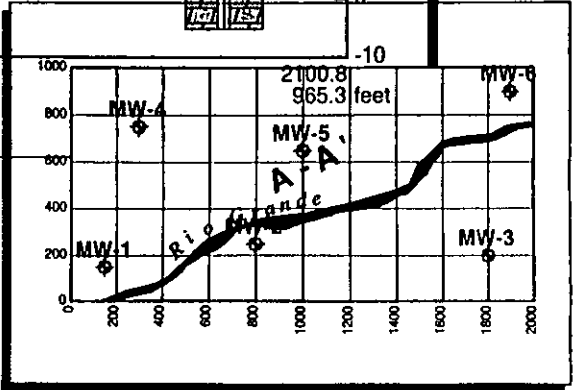
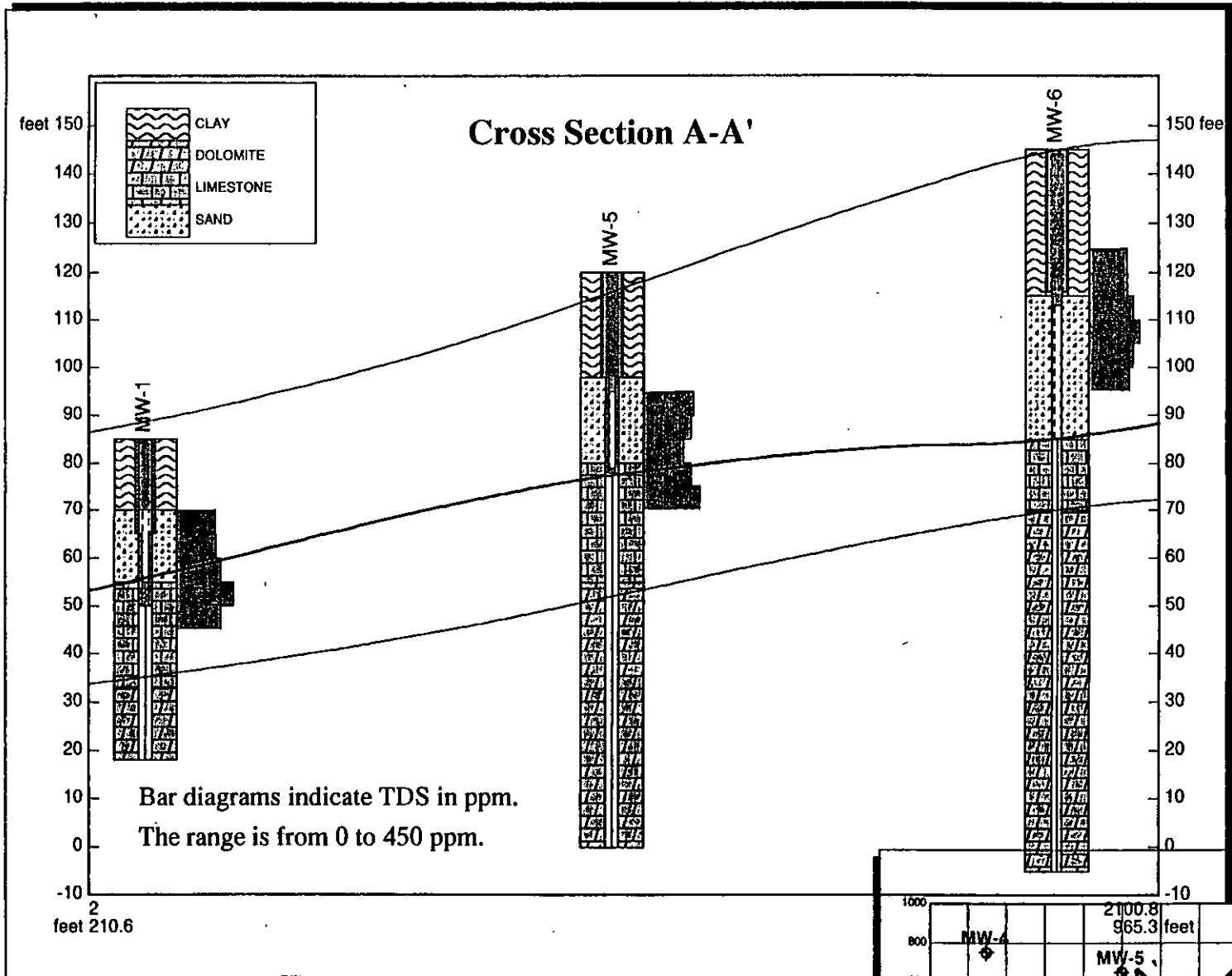

Elevation Contours of Limestone-Dolomite Bedrock (ft AMSL)

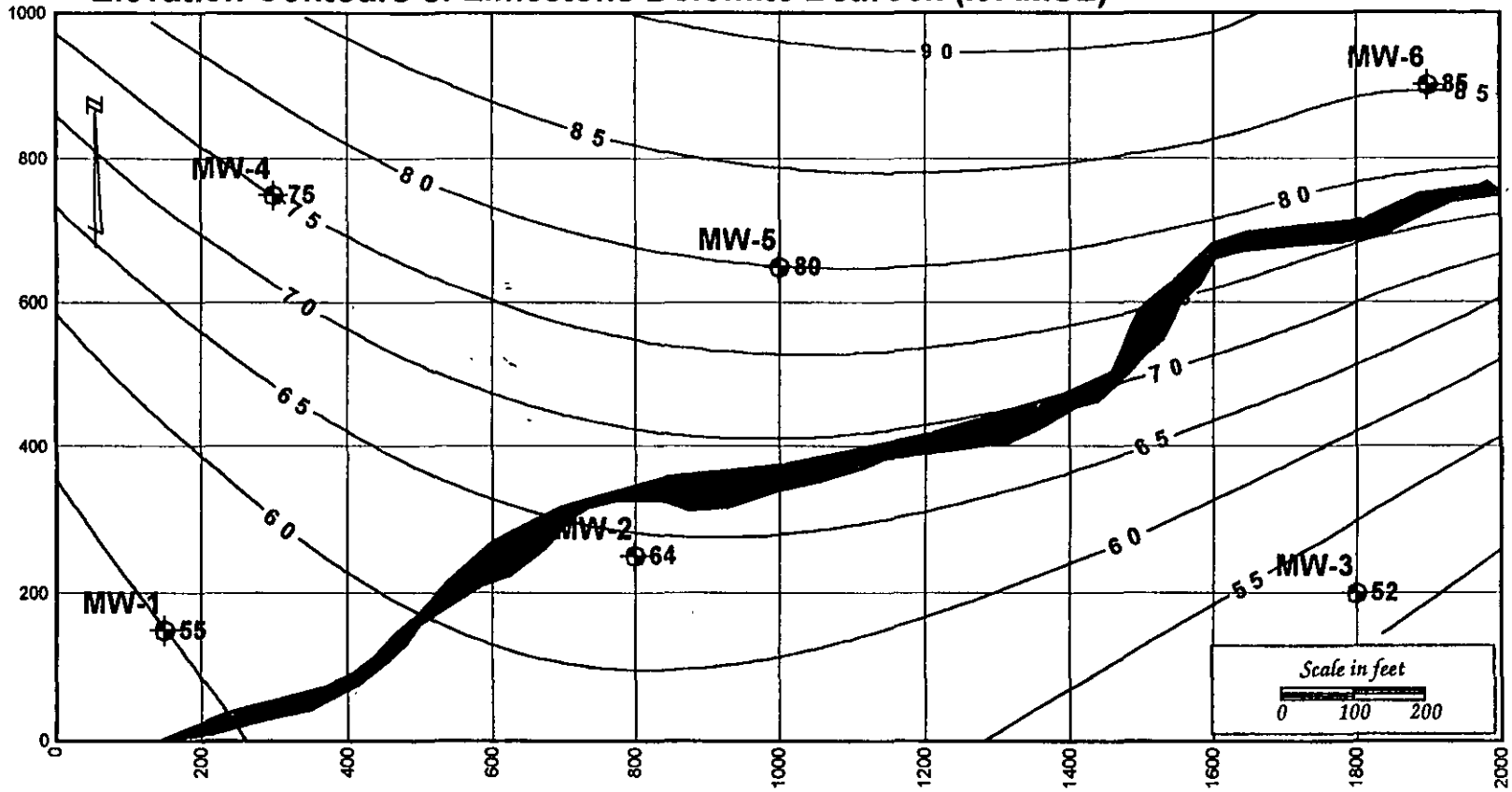

Well Ident

MW-6

STIFF Diagram

Name

Type

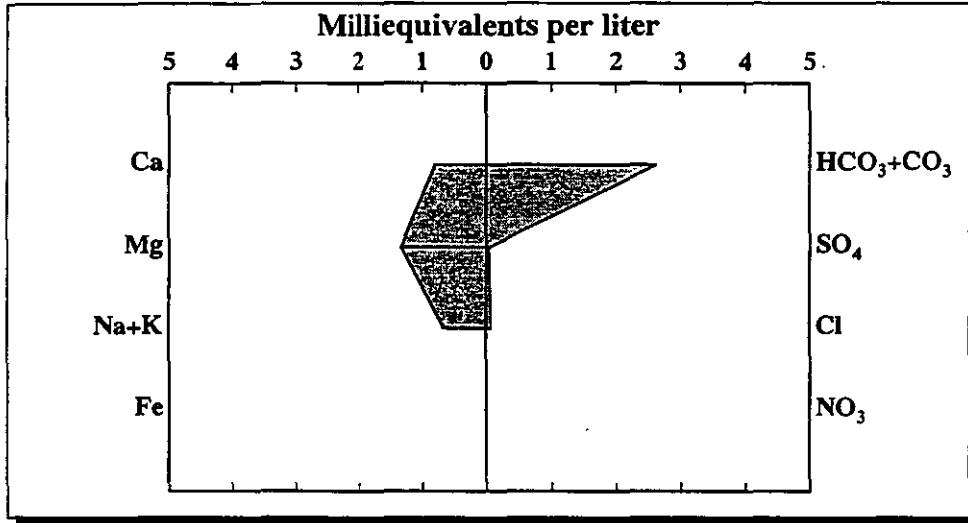

Cations

	<i>Ca</i>	<i>Mg</i>	<i>Na</i>	<i>K</i>	<i>Fe</i>
<i>Milliequivalents per liter</i>	0.7999	1.3301	0.6499	0.00997	
<i>Milligrams per liter</i>	16.03	16.17	14.94	0.39	

Anions

	<i>HCO3</i>	<i>CO3</i>	<i>SO4</i>	<i>Cl</i>	<i>NO3</i>
<i>Milliequivalents per liter</i>	2.61994		0.03997	0.08012	
<i>Milligrams per liter</i>	159.85		1.92	2.84	

BOD	COD	Diss. Oxygen	F	B	SiO2
TDS 213.00	Hardness	Alkalinity	Conductivity 250.00	pH 6.90	SAR 0.6297

Water Type

Magnesium Bicarbonate

Cations (epm) 2.79	Anions (epm) 2.74
-----------------------	----------------------

Aquifer

Error Balance (%)
0.90

Piper Diagram

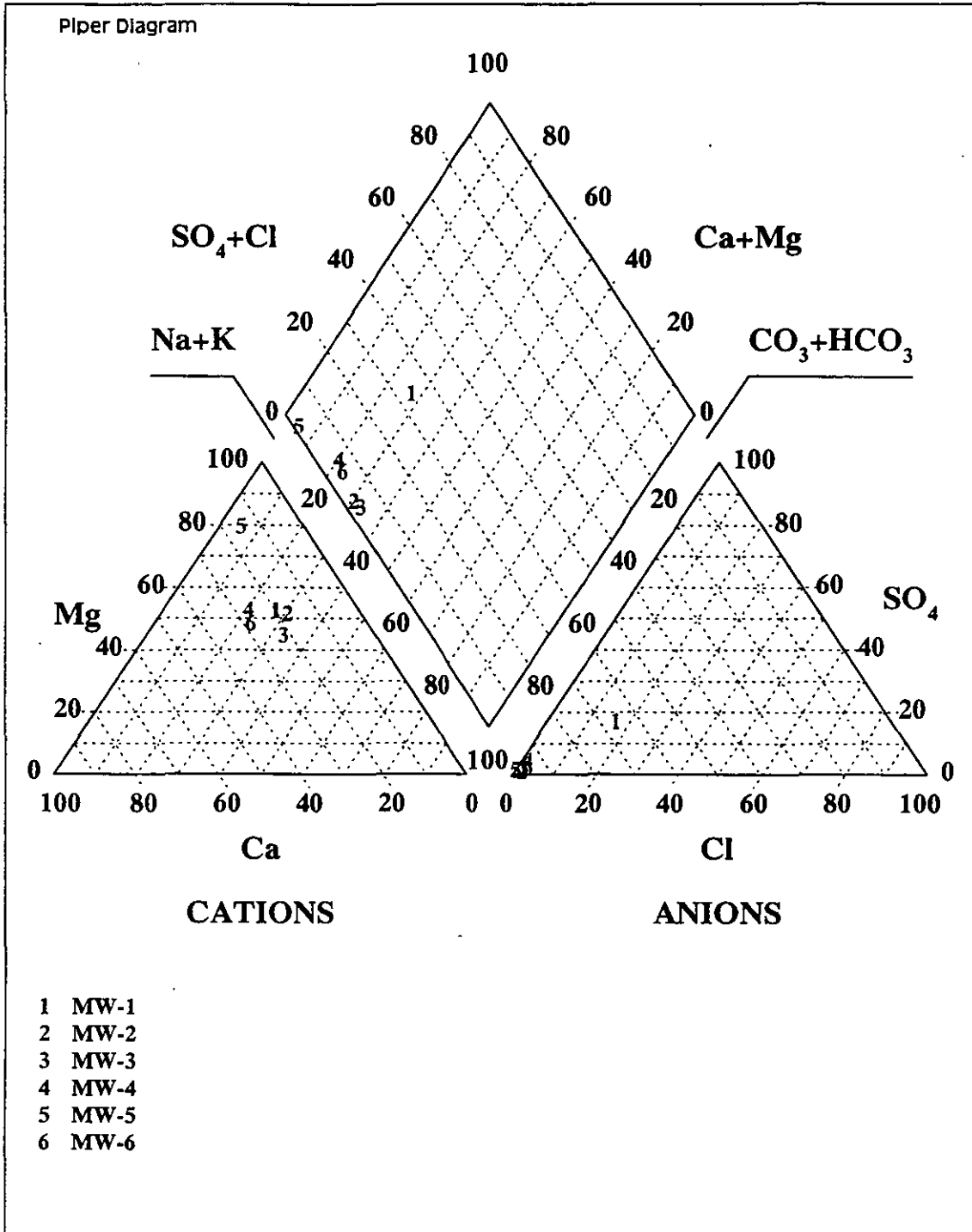

Wilcox Diagram

Wilcox Diagram

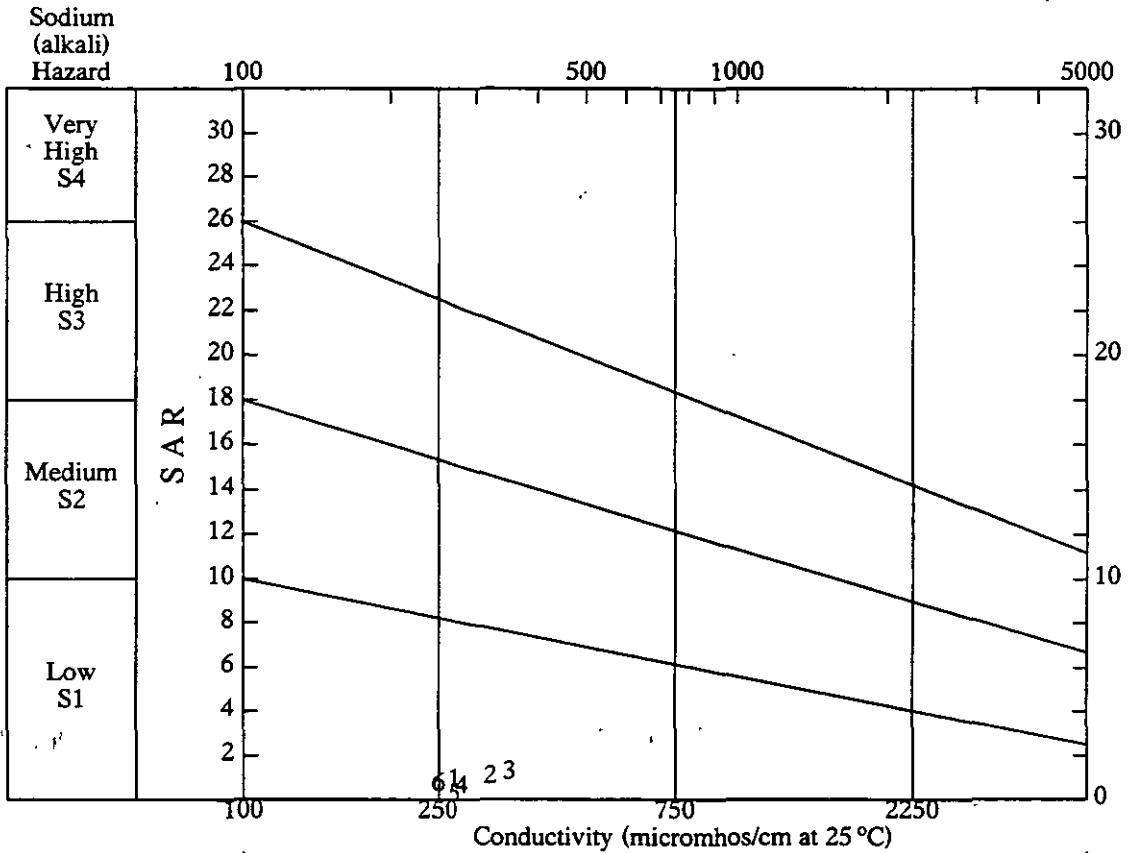

C1	C2	C3	C4
Low	Medium	High	Very High

Salinity Hazard

- 1 MW-1
- 2 MW-2
- 3 MW-3
- 4 MW-4
- 5 MW-5
- 6 MW-6

Schoeller Diagram

Schoeller Diagram

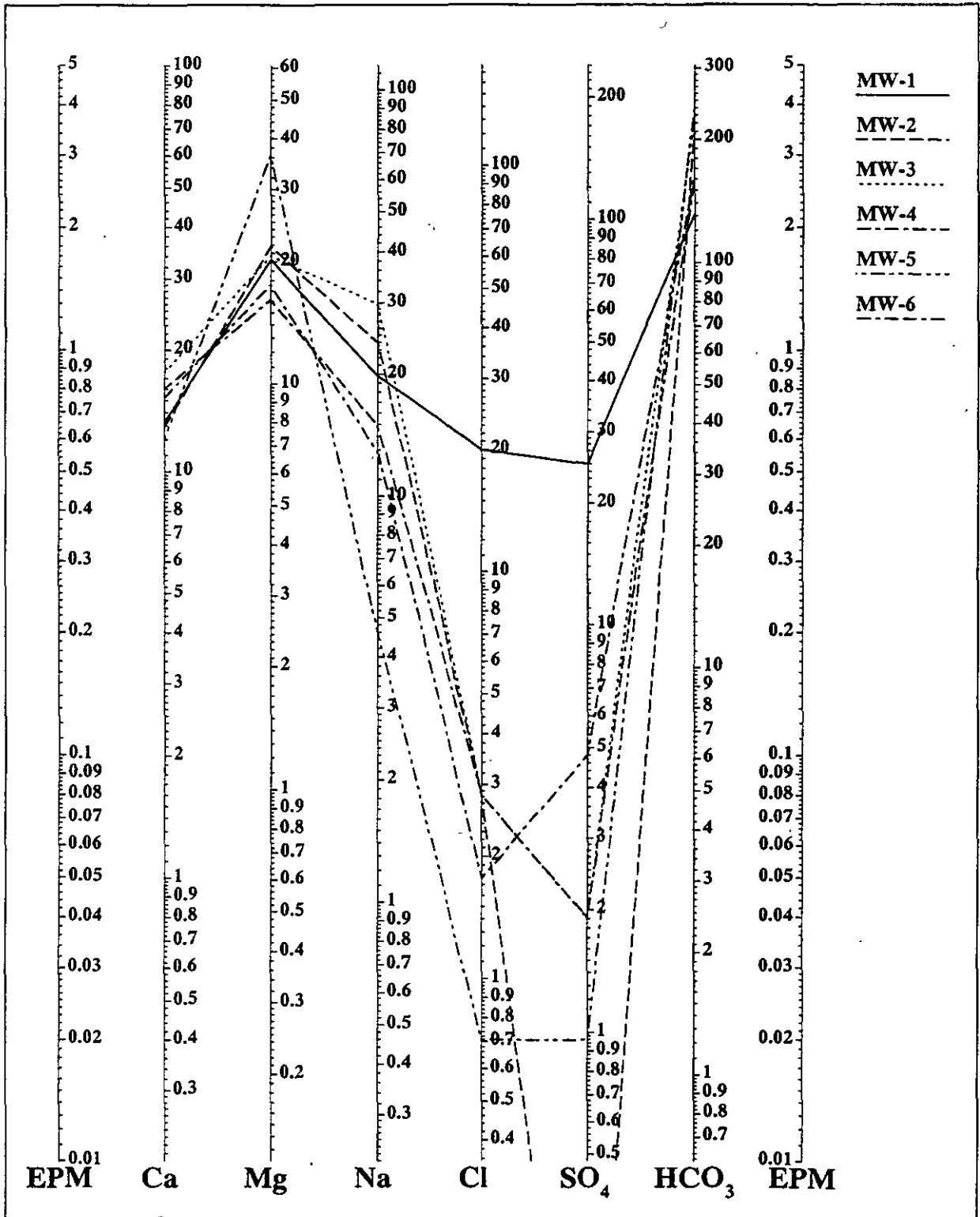

CONCENTRATION-DEPTH SERIES

Well Ident
MW-1

Name
Monitoring well in Corozo Pando

Easting (X) 150	Northing (Y) 150	Ground Surf. Elev. (Z) 85.00	Meas. Point Elev. (Zm) 86.00
---------------------------	----------------------------	--	--

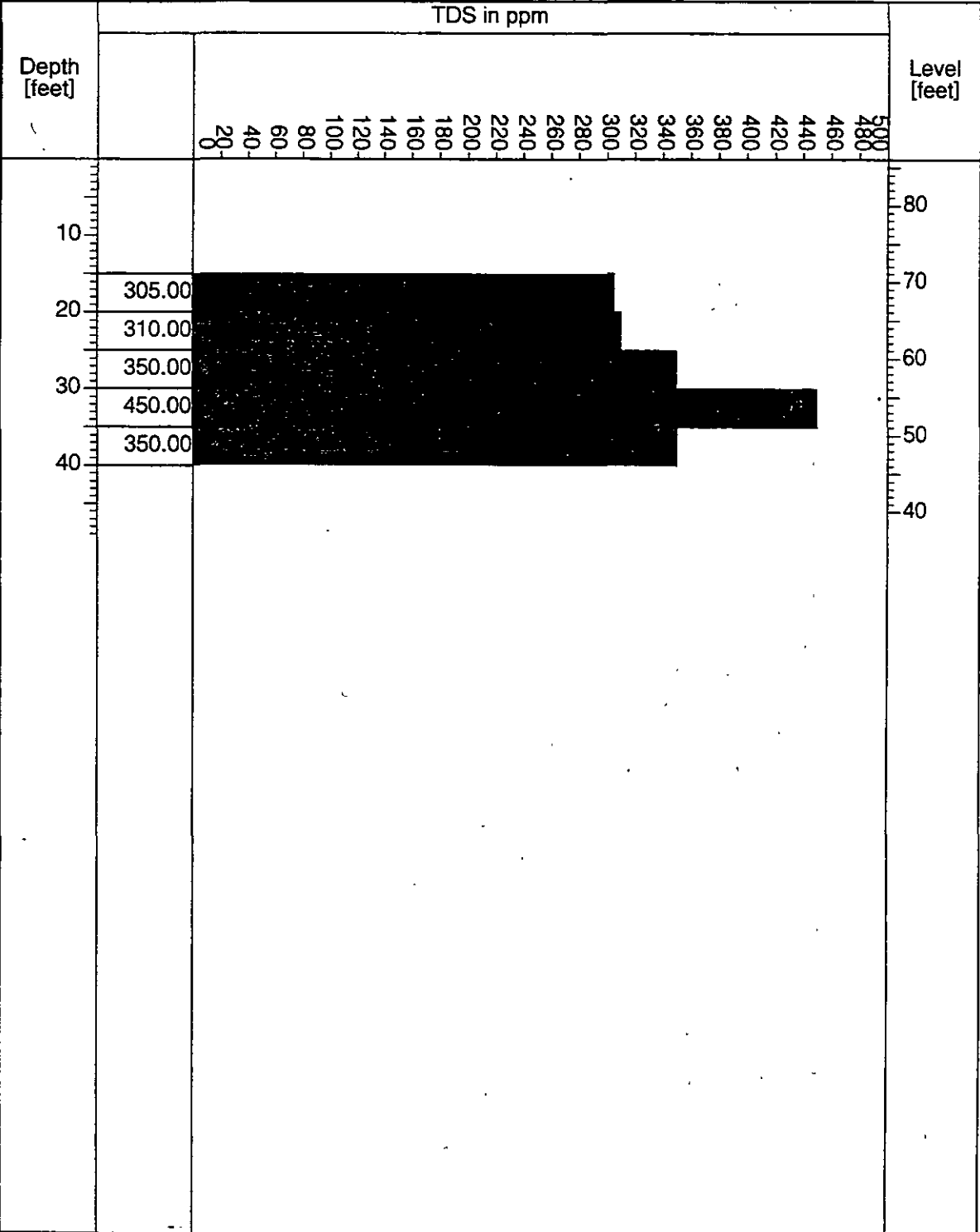

Chemistry Concentration / Time

Well Ident

MW-1

Name

Monitoring well in Corozo Pando

Easting (ft)

150

Northing (ft)

150

Gr. Surf. Elev. (ft amsl)

85.00

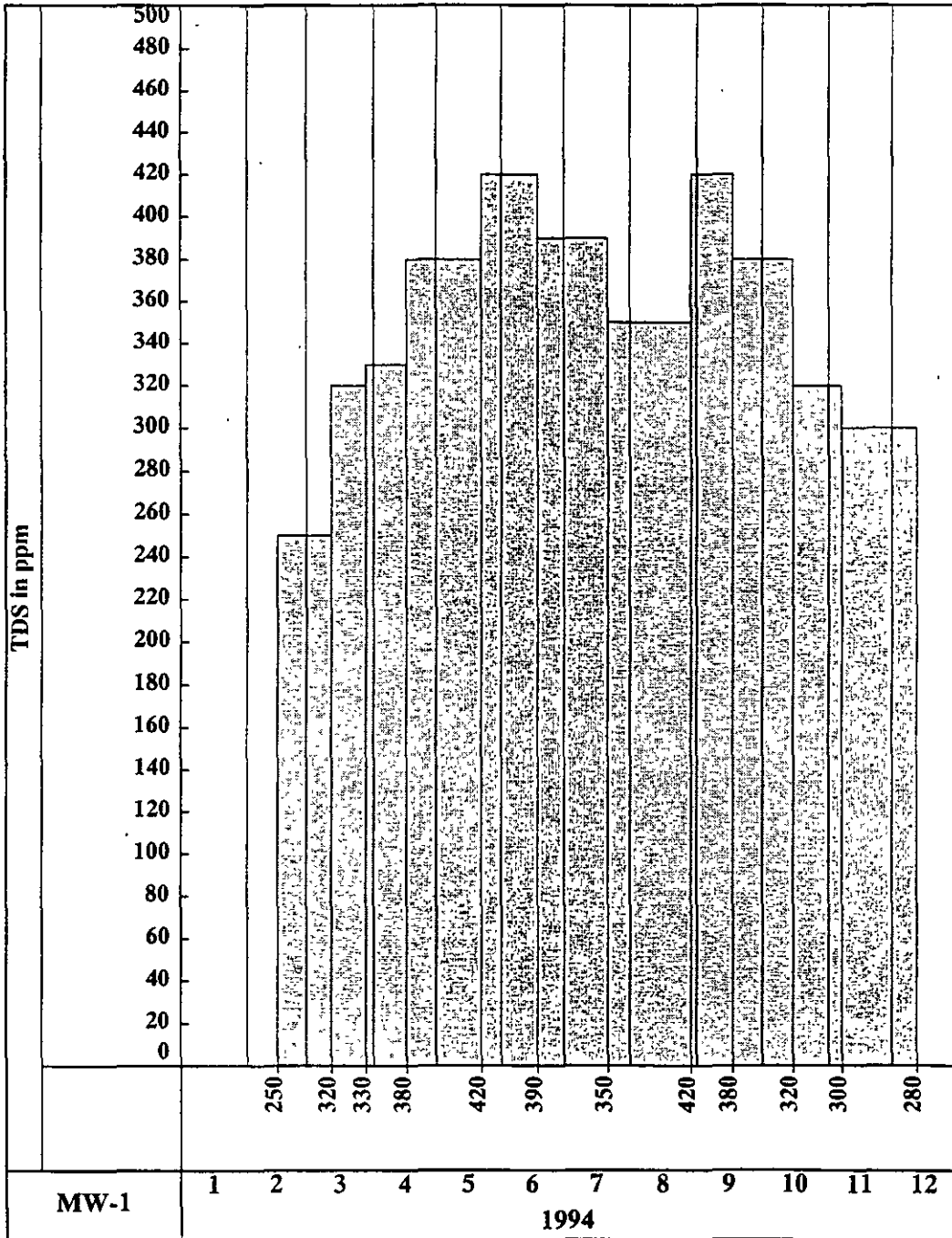

Pumping Test

Well Ident							
MW-1	<table border="1" style="width: 100%; border-collapse: collapse;"> <tr> <td colspan="2" style="text-align: center;">Name</td> </tr> <tr> <td colspan="2" style="text-align: center;">Monitoring well in Corozo Pando</td> </tr> </table>			Name		Monitoring well in Corozo Pando	
Name							
Monitoring well in Corozo Pando							
Obs. Well Distance [ft] 1.00	Average Pump. Rate [gpm] 300.00	Duration [min] 6870.0	Initial Sat. Thickness [ft]				
Results							
Transmissivity [gpd/ft] 21467	Storage Coefficient	Leakance [1/day] 36.634	Estimation Error [ft] 0.35				
Fit Method			Hantush Method				

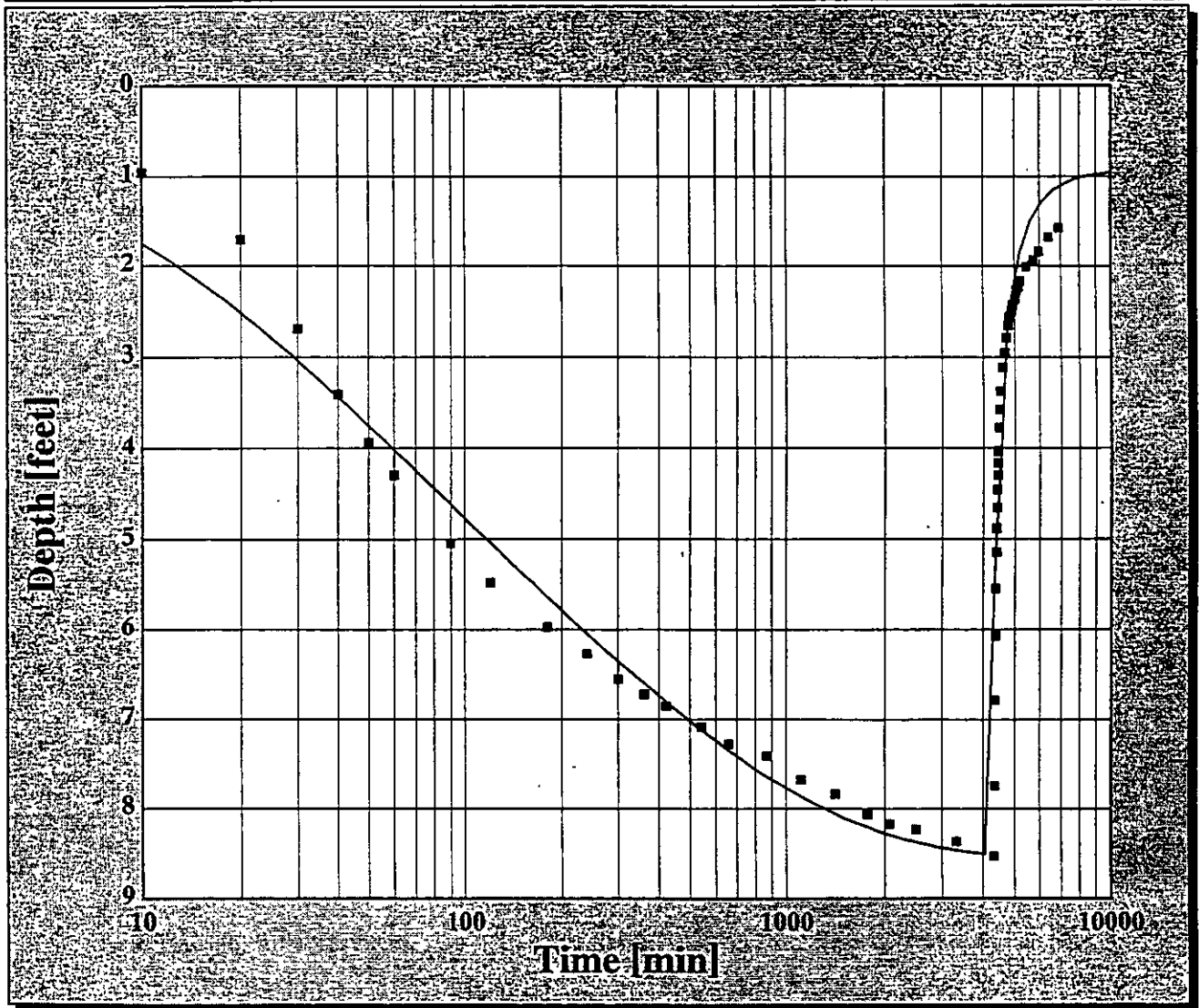

Pumping Test

Well Ident			
MW-6		Name	
Obs. Well Distance [ft] 1.00	Average Pump. Rate [gpm] 300.00	Duration [min] 72.000	Initial Sat. Thickness [ft]
Results			
Transmissivity [gpd/ft] 11398	Storage Coefficient	Leakance [1/day] 14.387	Estimation Error [ft] 0.53
Fit Method			Hantush Method

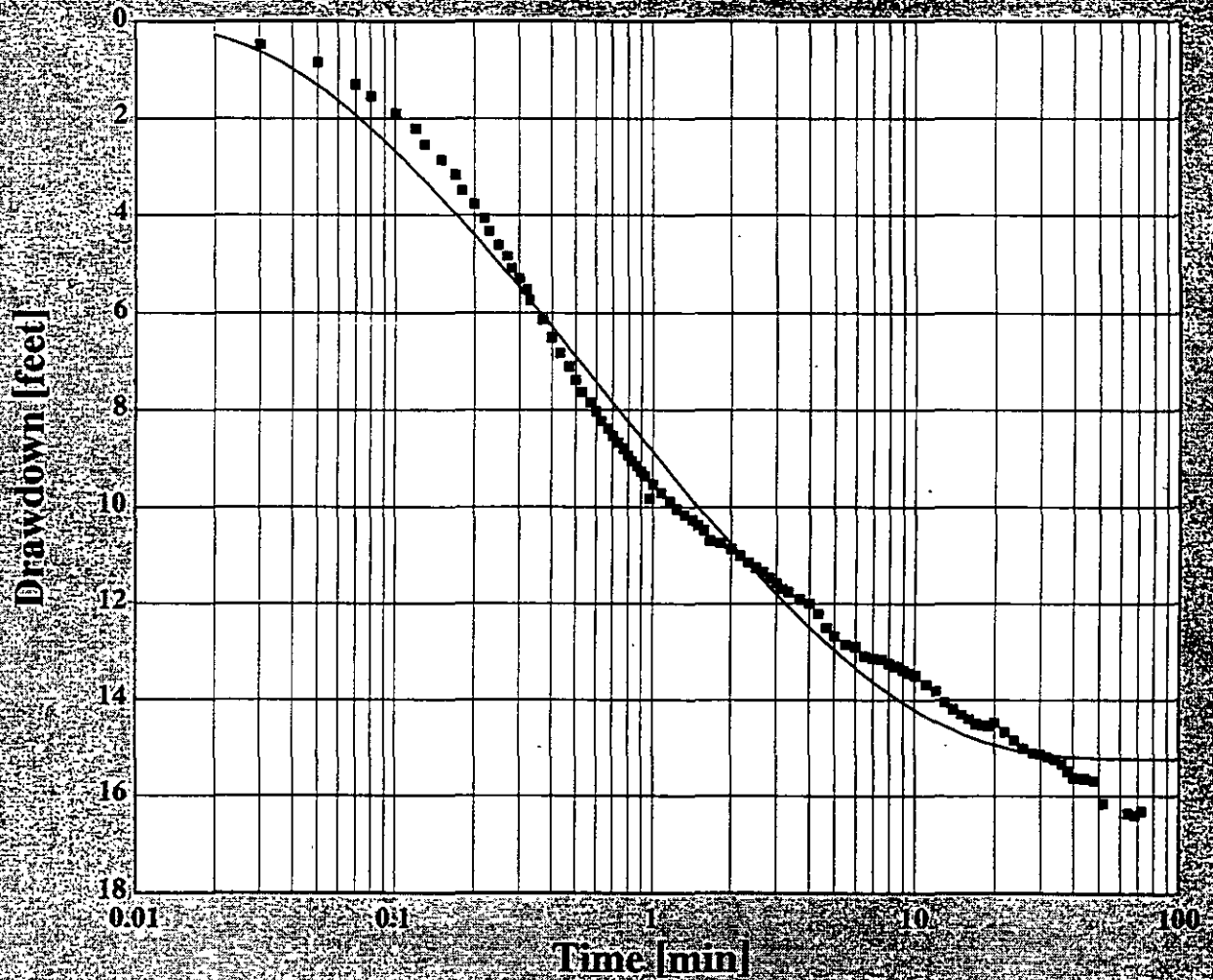

Hydrograph

Well Ident

MW-1

Name

Monitoring well in Corozo Pando

Easting (ft)

150

Northing (ft)

150

Ground Surf. Elev. (ft amsl)

85.00

Meas.Pt.Elev. (ft amsl)

86.00

Aquifer

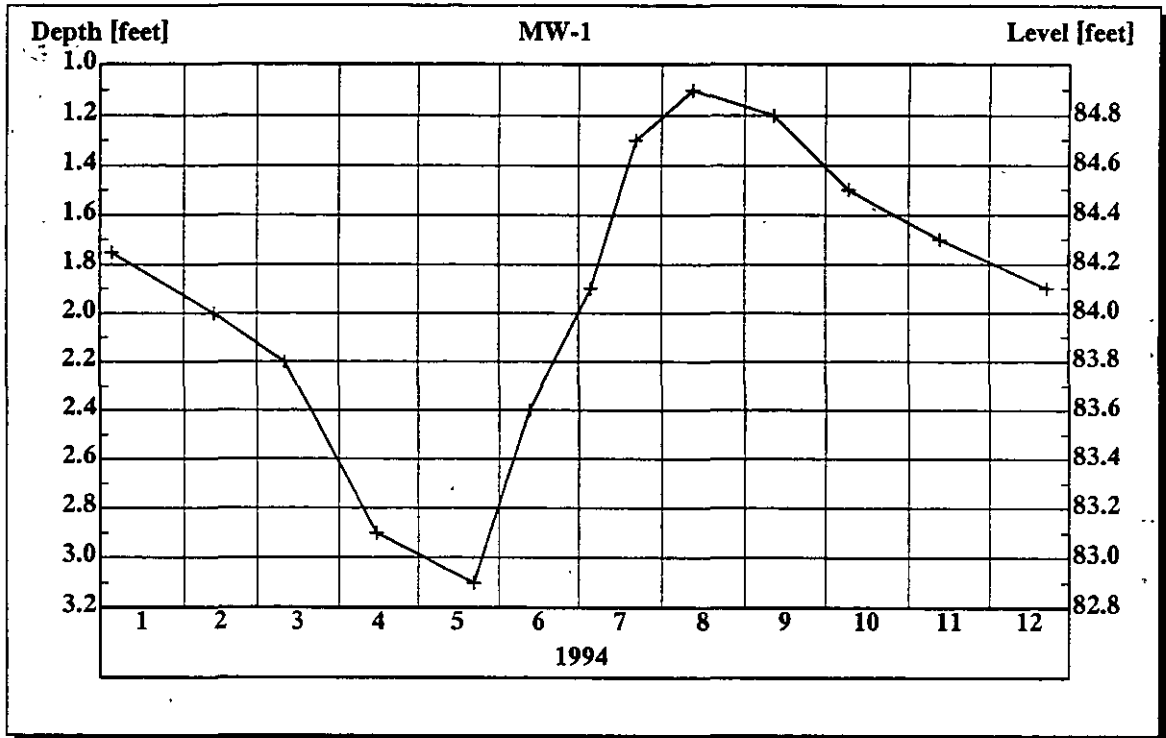

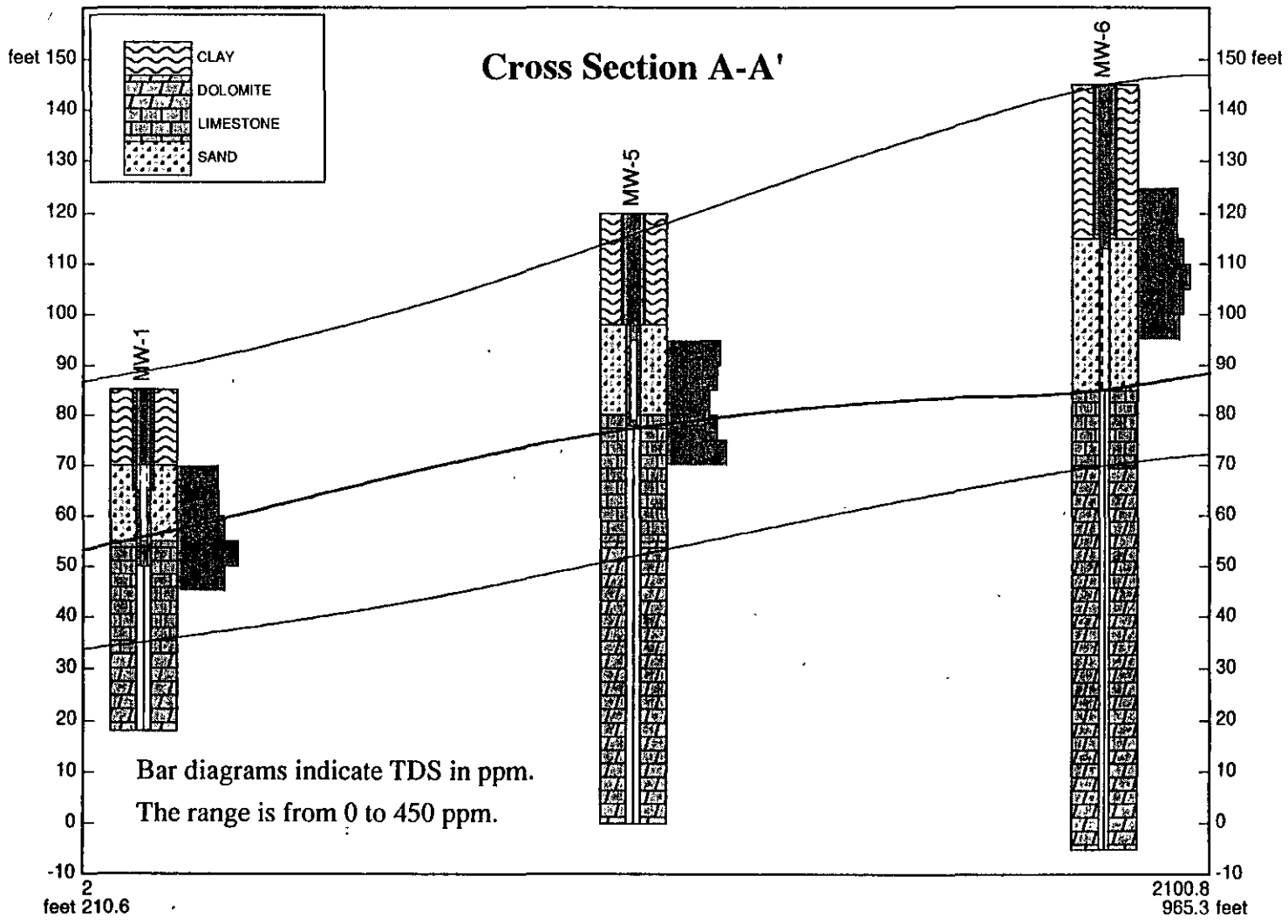

Ground Water for Windows (GWW) ... Example

TASK

1. Create a ground water data base with 6 wells. Each well has data on location, drilling (lithology and construction), chemistry (time series and depth-related); each well was pump tested; each well has one-year water level record.
2. Create contour maps for the following parameters:
 - Ground Surface Elevation
 - Total Dissolved Solids in ppm (TDS)
 - Contact boundary between Quaternary clay and sand (overburden) and underlying bedrock (limestone and dolomite).
 - Piezometric surface on 12 June 1994.
 - Transmissivity from pumping tests.
3. Create lithostratigraphic cross section connecting wells MW-1 and MW-2, with/without well construction details and with TDS as a function of depth.
4. Interpret pumping tests using the Theis and Hantush methods.
5. Create a fence diagram with all 6 wells. Connect various lithologic units and fill in with colored pattern.

INPUT DATA

Master Data

<Well Ident>	<X>	<Y>	<Z>	<ZM>
MW-1	150	150	85.00	86.00
MW-2	800	250	92.00	93.00
MW-3	1800	200	87.00	88.00
MW-4	300	750	110.00	111.00
MW-5	1000	650	120.00	121.00
MW-6	1900	900	145.00	146.00

HINT. You have two ways to input general/location data into GWW. The first way is to create an ASCII file such as above and import as **Standard ASCII Input** into Master application. The second way is to type the data directly into the GWW-created data base.

Chemical Data (Samples)

<Well Ident>	<Ca>	<Mg>	<Na>	<K>	<HCO3>	<SO4>	<Cl>	<TDS>	<Conductivity>	<pH>
MW-1	13.23	20.30	19.77	1.17	131.79	0.05	4.25	218.00	270.00	8.30
MW-2	12.83	21.88	23.91	2.35	206.83	0.05	2.84	272.00	320.00	7.00
MW-3	17.64	20.67	29.89	0.39	223.92	1.92	2.84	299.00	350.00	7.10
MW-4	15.23	17.63	12.87	0.78	162.90	4.80	1.77	218.00	280.00	7.30
MW-5	12.02	36.47	4.60	0.59	237.95	0.96	0.71	229.00	270.00	7.50
MW-6	16.03	16.17	14.94	0.39	159.85	1.92	2.84	213.00	250.00	6.90

HINT. Same as for Master Data, you may input data either by creating first an ASCII file as the one above, or by typing the data directly into the GWW-created data base.

Chemical Data (Depth-related)

MW-1		MW-2		MW-3		MW-4		MW-5		MW-6	
<Depth>	<TDS>	<Depth>	<TDS>	<Depth>	<TDS>	<Depth>	<TDS>	<Depth>	<TDS>	<Depth>	<TDS>
15	300	20	250	22	280	25	290	25	250	20	250
20	305	25	320	30	330	30	320	30	400	25	300
25	310	30	400	35	400	35	380	35	380	30	300
30	350	35	320	40	420	40	420	40	320	35	350
35	450	40	280	45	380	45	400	45	380	40	400
40	350	45	280	50	290	50	380	50	450	45	350
										50	320

Chemical Data (Time Series)

MW-1

<yyyy/mm/dd>	<TDS>
1994/02/15	250
1994/03/12	320
1994/03/28	330
1994/04/16	380
1994/05/22	420
1994/06/18	390
1994/07/21	350
1994/08/29	420
1994/09/17	380
1994/10/15	320
1994/11/07	300
1994/12/12	280

Lithologic Data

The data are contained in an ASCII file as shown below. If you decide to create a similar ASCII file you must follow the convention that each well must start with the word **WELL:** (terminated with colon), the lithology with the word **LITH:**, and the rest with words **SCREEN:**, **HOLE:**, **ANNULUS:**, and **CASING:**. Lithologic codes (CLAY, SAND, LIME, and DOLO) must be typed upper case, as four letter words; the same applies to the annular space materials (CEMENT, PACK, OPEN).

WELL: MW-1

LITH:

15.000 CLAY

30.00 SAND

52.00 LIME

67.00 DOLO

HOLE:

20.00 12.00

67.00 8.00

CASING:

20.00 8.25

35.00 4.00

SCREEN:

15.00 30.00

ANNULUS:

20.00 CEMENT

35.00 PACK

67.00 OPEN

WELL: MW-2

LITH:

12.00 CLAY

28.00 SAND

55.00 LIME

72.00 DOLO

HOLE:

20.00 12.00

72.00 8.00

CASING:

19.00 8.00

30.00 4.00

SCREEN:

15.00 28.00

ANNULUS:

20.00 CEMENT

32.00 PACK

72.00 OPEN

WELL: MW-3

LITH:

22.00 CLAY

35.00 SAND

55.00 LIME

70.00 DOLO

HOLE:

20.00 12.00

40.00 8.00

70.00 4.00

CASING:

20.00 8.00

38.00 5.00

SCREEN:

23.00 38.00

ANNULUS:

20.00 CEMENT

38.00 PACK

70.00 OPEN

WELL: MW-4

LITH:

20.00 CLAY

35.00 SAND

60.00 LIME

80.00 DOLO

HOLE:

20.00 14.00

38.00 12.00

80.00 4.00

CASING:

20.00 13.00

35.00 8.00

SCREEN:

22.00 35.00

ANNULUS:

20.00 CEMENT

35.00 PACK

80.00 OPEN

WELL: MW-5

LITH:

22.00 CLAY

40.00 SAND

65.00 LIME

120.00 DOLO
HOLE:
22.00 14.00
120.00 8.00
CASING:
22.00 12.00
42.00 4.00
SCREEN:
25.00 41.00
ANNULUS:
22000 CEMENT
42.00 PACK
120.00 OPEN
WELL: MW-6
LITH:
30.00 CLAY
60.00 SAND
75.00 LIME
150.00 DOLO

HOLE:
30.00 14.00
150.00 6.00
CASING:
29.00 12.00
60.00 6.00
SCREEN:
32.00 60.00
ANNULUS:
30.00 CEMENT
60.00 PACK
150.00 OPEN

Pumping Test Data

MW-1 (constant rate test: drawdown and recovery lumped together)

0.00	0.9510	300.0000
10.00	0.9510	300.0000
20.00	1.7060	300.0000
30.00	2.6900	300.0000
40.00	3.4110	300.0000
50.00	3.9360	300.0000
60.00	4.2970	300.0000
90.00	5.0510	300.0000
120.00	5.4780	300.0000

180.00	5.9700	300.0000
240.00	6.2650	300.0000
300.00	6.5600	300.0000
360.00	6.7240	300.0000
420.00	6.8550	300.0000
540.00	7.0850	300.0000
660.00	7.2820	300.0000
870.00	7.4130	300.0000
1110.00	7.6750	300.0000
1410.00	7.8390	300.0000
1770.00	8.0690	300.0000
2070.00	8.1670	300.0000
2490.00	8.2330	300.0000
3330.00	8.3640	300.0000
4320.00	8.5280	0.0000
4330.00	8.5280	0.0000
4340.00	7.7410	0.0000
4350.00	6.7900	0.0000
4360.00	6.0680	0.0000
4370.00	5.5430	0.0000
4380.00	5.1500	0.0000
4390.00	4.8870	0.0000
4400.00	4.6580	0.0000
4410.00	4.4610	0.0000
4420.00	4.2970	0.0000
4430.00	4.1660	0.0000
4440.00	4.0340	0.0000
4470.00	3.7720	0.0000
4500.00	3.5750	0.0000
4530.00	3.3780	0.0000
4590.00	3.1160	0.0000
4650.00	2.9520	0.0000
4710.00	2.7880	0.0000
4770.00	2.6570	0.0000
4830.00	2.5580	0.0000
4890.00	2.4930	0.0000
4950.00	2.4270	0.0000
5010.00	2.3620	0.0000
5070.00	2.2630	0.0000
5130.00	2.2300	0.0000
5190.00	2.1650	0.0000
5430.00	2.0010	0.0000
5730.00	1.9350	0.0000
5970.00	1.8370	0.0000

6390.00	1.6730	0.0000
6870.00	1.5740	0.0000

HINT. You do not need to repeat input of the pumping rate. It is sufficient to type 300 (gpm) on the first line, and skip the rest until the time when the pump is switched off. Type 0 for the pumping rate at 4320 minutes when the recovery of levels starts.

MW-4 (recovery test data)

0.00	0.0000	150.0000
240.00	3.2800	0.0000
241.00	2.9190	0.0000
242.00	2.6570	0.0000
243.00	2.4930	0.0000
245.00	2.2300	0.0000
247.00	2.0990	0.0000
250.00	1.8370	0.0000
255.00	1.6070	0.0000
260.00	1.4760	0.0000
270.00	1.2460	0.0000
280.00	1.1150	0.0000
300.00	0.9180	0.0000
320.00	0.7870	0.0000
340.00	0.6890	0.0000
380.00	0.5580	0.0000
420.00	0.4590	0.0000

MW-5 (constant rate test - drawdown portion)

0.00	0.0000	200.0000
1.00	0.6560	200.0000
1.50	0.8860	200.0000
2.00	0.9840	200.0000
2.50	1.1150	200.0000
3.00	1.2140	200.0000
4.00	1.3450	200.0000
5.00	1.4760	200.0000
6.00	1.5740	200.0000
8.00	1.7380	200.0000
10.00	1.8700	200.0000
12.00	1.9680	200.0000
14.00	2.0660	200.0000
18.00	2.1980	200.0000
24.00	2.3620	200.0000
30.00	2.4930	200.0000
40.00	2.6570	200.0000

50.00	2.7880	200.0000
60.00	2.9520	200.0000
80.00	3.0500	200.0000
100.00	3.1490	200.0000
120.00	3.2800	200.0000
150.00	3.4110	200.0000
180.00	3.5100	200.0000
210.00	3.6080	200.0000
240.00	3.6740	200.0000

You do not need to type the pumping rate 200 gpm more than once on the first line.

MW-6 (constant-rate test - drawdown portion)

0.02	0.1740	300.0000
0.03	0.4720	300.0000
0.05	0.8330	300.0000
0.07	1.2890	300.0000
0.08	1.5480	300.0000
0.10	1.8890	300.0000
0.12	2.2070	300.0000
0.13	2.5390	300.0000
0.15	2.8630	300.0000
0.17	3.1680	300.0000
0.18	3.4830	300.0000
0.20	3.7690	300.0000
0.22	4.0480	300.0000
0.23	4.3100	300.0000
0.25	4.6050	300.0000
0.27	4.8350	300.0000
0.28	5.0810	300.0000
0.30	5.3040	300.0000
0.32	5.5230	300.0000
0.33	5.7370	300.0000
0.37	6.1470	300.0000
0.40	6.5010	300.0000
0.43	6.8260	300.0000
0.47	7.1140	300.0000
0.50	7.3770	300.0000
0.53	7.6230	300.0000
0.57	7.8390	300.0000
0.60	8.0330	300.0000
0.63	8.2260	300.0000
0.67	8.3770	300.0000
0.70	8.5250	300.0000

0.73	8.6630	300.0000
0.77	8.7870	300.0000
0.80	8.9250	300.0000
0.83	9.0460	300.0000
0.87	9.1610	300.0000
0.90	9.2630	300.0000
0.93	9.3610	300.0000
0.97	9.8200	300.0000
1.00	9.5320	300.0000
1.08	9.7120	300.0000
1.17	9.8790	300.0000
1.25	10.0330	300.0000
1.33	10.1550	300.0000
1.42	10.2630	300.0000
1.50	10.3650	300.0000
1.58	10.4760	300.0000
1.67	10.6930	300.0000
1.83	10.7350	300.0000
2.00	10.8700	300.0000
2.17	11.0080	300.0000
2.33	11.1450	300.0000
2.50	11.2500	300.0000
2.67	11.3320	300.0000
2.83	11.4540	300.0000
3.00	11.5750	300.0000
3.17	11.6870	300.0000
3.33	11.7520	300.0000
3.67	11.9130	300.0000
4.00	12.0010	300.0000
4.33	12.2110	300.0000
4.67	12.5100	300.0000
5.00	12.6770	300.0000
5.50	12.8610	300.0000
6.00	12.9030	300.0000
6.50	13.1000	300.0000
7.00	13.1460	300.0000
7.50	13.1630	300.0000
8.00	13.2550	300.0000
8.50	13.3100	300.0000
9.00	13.3890	300.0000
9.50	13.4610	300.0000
10.00	13.4940	300.0000
11.00	13.6910	300.0000
12.00	13.8220	300.0000

13.00	14.0520	300.0000
14.00	14.1830	300.0000
15.00	14.3140	300.0000
16.00	14.3990	300.0000
17.00	14.5170	300.0000
18.00	14.5370	300.0000
19.00	14.5600	300.0000
20.00	14.4780	300.0000
22.00	14.6750	300.0000
24.00	14.8550	300.0000
26.00	15.0160	300.0000
28.00	15.1170	300.0000
30.00	15.1340	300.0000
32.00	15.2030	300.0000
34.00	15.2490	300.0000
36.00	15.3410	300.0000
38.00	15.4950	300.0000
40.00	15.6260	300.0000
44.00	15.6520	300.0000
48.00	15.6880	300.0000
52.00	16.1510	300.0000
64.00	16.3570	300.0000
68.00	16.3930	300.0000
72.00	16.3050	300.0000

Water Level Data

MW-1

150 150 85.00 86.00
 <yy/mm/dd> <Level>
 94/01/05 84.25
 94/02/12 84
 94/03/11 83.8
 94/04/15 83.1
 94/05/22 82.9
 94/06/12 83.6
 94/07/05 84.1
 94/07/22 84.7
 94/08/12 84.9
 94/09/11 84.8
 94/10/09 84.5
 94/11/12 84.3

: Line 1, contains well name
 : Line 2, intended for location, blank here
 : Line 3, intended for aquifer, blank here
 : Line 4, X, Y, Z, ZM, respectively
 : Line 5, tells GWW the format for date
 : Line 6 till end, water level data entry

94/12/22 84.1

*

MW-2

800 250 92.00 93.00

<yy/mm/dd> <Level>

94/01/05 91.25

94/02/12 91

94/03/11 90.8

94/04/15 90.1

94/05/22 89.9

94/06/12 90.6

94/07/05 91.1

94/07/22 91.7

94/08/12 91.9

94/09/11 91.8

94/10/09 91.5

94/11/12 91.3

94/12/22 91.1

*

MW-3

1800 200 87.00 88.00

<yy/mm/dd> <Level>

94/01/05 86.25

94/02/12 86

94/03/11 85.8

94/04/15 85.1

94/05/22 84.9

94/06/12 85.6

94/07/05 86.1

94/07/22 86.7

94/08/12 86.9

94/09/11 86.8

94/10/09 86.5

94/11/12 86.3

94/12/22 86.1

*

MW-4

300 750 110.00 111.00

<yy/mm/dd> <Level>

94/01/05 108.25

94/02/12 108

94/03/11 107.8

94/04/15 107.1

94/05/22 106.9

94/06/12 106.6

94/07/05 108.1

94/07/22 108.7

94/08/12 108.9

94/09/11 108.8

94/10/09 108.5

94/11/12 108.3

94/12/22 108.1

*

MW-5

1000 650 120.00 121.00

<yy/mm/dd> <Level>

94/01/05 109.25

94/02/12 109

94/03/11 108.8

94/04/15 108.1

94/05/22 107.4

94/06/12 107.9

94/07/05 108.8

94/07/22 109.7

94/08/12 109.9

94/09/11 109.8

94/10/09 109.5

94/11/12 109.3

94/12/22 109.1

*

MW-6

1900 900 145.00 146.00

<yy/mm/dd> <Level>

94/01/05 143.25

94/02/12 143

94/03/11 142.8

94/04/15 142.1

94/05/22 141.9

94/06/12 142.6
 94/07/05 143.1
 94/07/22 143.4
 94/08/12 143.4
 94/09/11 143.3
 94/10/09 143.3
 94/11/12 143.1
 94/12/22 142.8

*

Elevation of various lithologic units

	Clay-Sand	Sand-Limestone	Limestone-Dolomite
MW-1	70.0	55.0	33.0
MW-2	80.0	64.0	37.0
MW-3	55.0	52.0	32.0
MW-4	90.0	75.0	50.0
MW-5	98.0	80.0	55.0
MW-6	115.0	85.0	70.0

Hint. Type these numbers into entry form for Well Logs. The first column of numbers refers to the elevation of the contact between clay and sand layers (in feet above mean sea level), the second to the contact between sand and limestone, and the third to the contact between limestone and dolomite.

OUTPUTS

Some of outputs (printouts, reports) are appended to this exercise.

1. Well construction and lithologic log for well MW-1.
2. Same for well MW-6.
3. Pumping test interpretation for well MW-4 (recovery method).
4. Pumping test interpretation for well MW-1 (drawdown and recovery).
5. Pumping test interpretation for well MW-2.
6. Time series for TDS in well MW-1.
7. TDS versus depth in well MW-1.
8. TDS contour map.
9. Piper diagram with 6 samples.
10. Wilcox diagram.
11. Schoeller diagram.
12. STIFF diagram for well MW-1.
13. Piezometric contour map on 12 June 1994.
14. Elevation contours of limestone-dolomite bedrock
15. Lithologic cross section MW-1 - MW-2.
16. Fence diagram.
17. A Hydrograph.

Well Log: Lithology & Construction

Well Ident
MW-2

Name

Drill. Method

Drill. Dates

X 800

Y 250

Z 92.00

Meas. Pt. Elev. 93.00

All measurements are in feet. Hole and casing diameters in inches.

Scales (1: xxx)

Water Level (ft AMSL)

Vertical

Horizontal

40.0

Depth [feet]	Hole	Annulus	Casing	Screen	Lithology	Elev. [feet]
5					CLAY	90
10	12	Conductor Pipe Cemented in	8			85
15					SAND	80
20	20	Gravel Pack Well thoroughly developed for 24 hours by pumping and surging	20	15		75
25			4	28		70
30			30		LIMESTONE	65
35						60
40						55
45	8					50
50		Open hole			DOLOMITE	45
55						40
60						35
65					30	
70	72				25	

APPENDIX B

DATA BASE STRUCTURE FILES

These are internal files, contained within the data base template, GWW.000. You may retrieve the files by following the steps:

1. Select Tools.
2. Select Data Structure Design.
3. Select File.
4. Select Old.
5. Select any name or application from the list.
6. Close the dialogue box by clicking on OK.
7. Select Write Structure to STD ASCII
8. Type an ASCII filename under which this file will be saved.

MASTER DATA STRUCTURE

DATA ENTRY	No. of Characters	Data Type	Format	No. of Decimal Digits	Unit
Well Ident	10	Well			
Description	50	Char			
District	20	Char			
Locality	20	Char			
Owner	20	Char			
X	10	Num(Dim)	Fixed	2	m
Y	10	Num(Dim)	Fixed	2	m
Z	10	Num(Dim)	Fixed	2	m
ZM	10	Num(Dim)	Fixed	2	m
Map Sheet No.	10	Char			
Year	10	Char			

CHEMICAL DATA STRUCTURE

DATA ENTRY	No. of Characters	Data Type	Format	No. of Decimal Digits	Unit
Well Ident	10	Well			
Ca	10	Num(Und)	Fixed	2	
Mg	10	Num(Und)	Fixed	2	
Na	10	Num(Und)	Fixed	2	
K	10	Num(Und)	Fixed	2	
Fe	10	Num(Und)	Fixed	2	
Mn	10	Num(Und)	Fixed	2	
HCO3	10	Num(Und)	Fixed	2	
CO3	10	Num(Und)	Fixed	2	
SO4	10	Num(Und)	Fixed	2	
Cl	10	Num(Und)	Fixed	2	
NO3	10	Num(Und)	Fixed	2	
NO2	10	Num(Und)	Fixed	2	
PO4	10	Num(Und)	Fixed	2	
F	10	Num(Und)	Fixed	2	
B	10	Num(Und)	Fixed	2	
SiO2	10	Num(Und)	Fixed	2	
TDS	10	Num(Und)	Fixed	2	
Hardness	10	Num(Und)	Fixed	2	
Alkalinity	10	Num(Und)	Fixed	2	
Conductivity	10	Num(Und)	Fixed	2	
pH	10	Num(Und)	Fixed	2	
Cations	8	Num(Und)	Fixed	2	
Anions	8	Num(Und)	Fixed	2	
SAR	8	Num(Und)	Fixed	4	
BalErr	8	Num(Und)	Fixed	2	

CHEMICAL DATA STRUCTURE

FOR PARTS PER MILLION ENTRIES

DATA ENTRY	No. of Characters	Data Type	Format	No. of Decimal Digits	Unit
Cappm	10	Num(Und)	Fixed	2	
Mgppm	10	Num(Und)	Fixed	2	
Nappm	10	Num(Und)	Fixed	2	
Kppm	10	Num(Und)	Fixed	2	
Feppm	10	Num(Und)	Fixed	2	
Mnppm	10	Num(Und)	Fixed	2	
HCO3ppm	10	Num(Und)	Fixed	2	
CO3ppm	10	Num(Und)	Fixed	2	
SO4ppm	10	Num(Und)	Fixed	2	
Clppm	10	Num(Und)	Fixed	2	
NO3ppm	10	Num(Und)	Fixed	2	
PO4ppm	10	Num(Und)	Fixed	2	
Bppm	10	Num(Und)	Fixed	2	
SiO2ppm	10	Num(Und)	Fixed	2	

PUMPING TEST DATA STRUCTURE

DATA ENTRY	No. of Characters	Data Type	Format	No. of Decimal Digits	Unit
Well Ident	10	Well			
TestDate	10	Date	dd.mm.yy		
Distance	10	Num(Dim)	Fixed 2	m	
AvgPRate	15	Num(Dim)	Float 7	m ³ /day	
Duration	15	Num(Dim)	Float 7	min	
InSatTh	15	Num(Dim)	Fixed 2	m	
Transmissivity	15	Num(Dim)	Float 7	m ² /day	
Storage	15	Num(Und)	Float 7		
Leakance	15	Num(Dim)	Float 7	1/day	
ConfAqThickness	10	Num(Dim)	Fixed 2	m	
b	10	Num(Dim)	Fixed 2	m	
l	10	Num(Dim)	Fixed 2	m	
d	10	Num(Dim)	Fixed 2	m	
l1	10	Num(Dim)	Fixed 2	m	
d1	10	Num(Dim)	Fixed 2	m	
StandardError	10	Num(Dim)	Fixed 2	m	
Method	25	Char			

PUMPING TEST ADDITIONAL DATA STRUCTURE

DATA ENTRY	No. of Characters	Data Type	Format	No. of Decimal Digits	Unit
Time	10	Char			
Drawdown	10	Char			
PRate	10	Char			
Selection	10	Char			
EstValues	10	Char			
Difference	10	Char			

HYDROGRAPHS DATA STRUCTURE

DATA ENTRY	No. of Characters	Data Type	Format	No. of Decimal Digits	Unit
Well Ident	10	Well			
Aquifer	30	Char			

HYDROGRAPHS ADDITIONAL DATA STRUCTURE

DATA ENTRY	No. of Characters	Data Type	Format	No. of Decimal Digits	Unit
Date	10	Date	mm/dd/yy		
Time	10	Time	hhmm:ss		
Depth	10	Num(Dim)	Fixed	2	m
Level	10	Num(Dim)	Fixed	2	m

WELL LOG AND LITHOLOGY DATA STRUCTURE

DATA ENTRY	No. of Characters	Data Type	Format	No. of Decimal Digits	Unit
Well Ident	10	Well			
Drill Dates	25	Char			
SWL	10	Num(Dim)	Fixed	2	m
DWL	10	Num(Dim)	Fixed	2	m
Drill Method	30	Char			
ConcrBlockDx	10	Num(Dim)	Fixed	2	m
ConcrBlockDy	10	Num(Dim)	Fixed	2	m
ConcrBlockH	10	Num(Dim)	Fixed	2	m
Above GS	10	Num(Dim)	Fixed	2	m
Vert.Scale	10	Num(Und)	Fixed	1	
Hor.Scale	10	Num(Und)	Fixed	1	

STEP DRAWDOWN TEST DATA STRUCTURE

DATA ENTRY	No. of Characters	Data Type	Format	No. of Decimal Digits	Unit
Well Ident	10	Well			
A	12	Num(Und)	Float	4	
B	12	Num(Und)	Float	4	
p	10	Num(Und)	Fixed	2	
Efficiency	10	Num(Und)	Fixed	2	

GRAIN SIZE CURVE DATA STRUCTURE

DATA ENTRY	No. of Characters	Data Type	Format	No. of Decimal Digits	Unit
Well Ident	10	Well			

APPENDIX C .. ENTRY AND REPORTING FORMS

PART ONE: ENTRY FORMS

MASTER DATA ENTRY FORMS (in English, Portuguese, and Spanish)

Standard			
Master Data			
Identification	Type	Acollar	
Name			
Region		District	
Easting (m)	Northing (m)	Or. Surf. El. (m amsl)	Mean. Pl. El. (m amsl)
		Type: Label: x,y [mm] dx,dy	

Standard			
DADOS PRINCIPAIS CORSAN SISTEMA DE INFORMAÇÕES DE ÁGUA SUBTERRÂNEA			
Poço #		Município	
X (m, UTM)	Y (m, UTM)	Z (m)	Zm (m, Medição de Nível)
		Type: Label: x,y [mm] dx,dy	

Standard			
VALLE DE CONSTANZA ... INDRHI			
COD. POZO			
UBICACION			
DESCRIPCION			
X	Y	Z	ZM
PROPIET.		USO	
TOPE DEL ACUFERO		FONDO DEL ACUFERO	
		Type:	

CHEMICAL DATA ENTRY FORMS

Standard				
Identification		CHEMICAL DATA		
		Source Type	Aquifer	
Easting (ft)	Northing (ft)	Date of Sample	Date of Analysis	Lab. Sample ID
Temperature (°C)	EC (µmhos/cm)	pH	Eh	De. Oxygen
Ca	Mg	Na	K	
HCO3	Cl	SO4	NO3	
TDS (ppm)	Hardness	Alkalinity	SiO2	
Fe	B	BOD	COD	
Reference		Validation		Units

Organics					
ORGANICS IN WATER AND SOIL					
Well Ident	Date Chem (mm/dd/yy)	Soil/Water	Depth (ft BGS)	1,1,1-Trichloroethane	
1,1,2-Trichloroethane	1,1-Dichloroethane	1,1-Dichloroethane	1,2-Dichloroethane	1,2-Dichloroethane	Chloroform
Toluene	2-Methoxy-2-methylpropane	1-(2-Methoxypropoxy-2-propanol)		1-(2-Methoxy-1-methylpropanol)	
Hexamethylheptacosane	Hexadecamethylheptacosane	Dodecanoic acid	N-Methyl-N-glycine	Tetradecamethylhexa	
Benzene	Ethylbenzene	Chloroethane	Tetrahydrofuran	Methylene Chloride	Trichloroethene
Xylene	Acetone	Methyl Ethyl Ketone	2-Hexanone	Carbon Disulfide	4-Methyl-2-Pentanone
Hexane	Tetrachloroethene	Vinyl Chloride	PCB-1260	Phenol	Phenanthrene
bis(2-ethylhexyl)phthalate	Fluoranthene	Benzo(a)pyrene	Pyrene	Benzo(a)anthracene	
1,3-Dioxolane	2,7,10-Trimethyldecane	1,12-Tridecadiene	Fluorotrichloromethane	Cyclohexane	
Methylcyclopentane	3-Methyl-Pentane	Cyclopentane	2-Methyl-Pentane	Hydrocarbon C7H14	Methyl Cyclohexane

PUMPING TEST ENTRY FORMS (in English and Portuguese)

Partial Penetration			
Pumping Test Data			
Identification	Type	Aquifer	
	Easting (m)		Northing (m)
Obs. Well Distance	Average Q	Duration	Init. Sat. Thick.
Partial Penetration Well Data			
		Screen Beginning	Screen Ending
Aquifer Thickness	Production Well		
	Observation Well		
Results			
Transmissivity	Storage Coefficient		Leakance
Fit Method			Estimation Error
Transmissivity Selected	Storage Coeff. Selected		Hydr. Cond. Selected
Reference		Validation	

Standard			
Dados de Teste de Bombeamento			
Poço	Tipo de Poço	Aquífero	
	X (m)		Y (m)
Dist. Poço Obs.	Q média	Duração	Expos. Sat. Inc.
Resultados			
Transmissividade	Coef. Armazen.		Carregamento
Método			Erro Estimado
Transmissividade Seleccionada (m²/h)		Coef. Armazen. Seleccionada	
Cond. Hídr. Seleccionada (m/h)			
Referência		Visto	

HYDROGRAPHS ENTRY FORM

Standard			
Water Levels			
Identification		Type	Aquifer
Easting (m)	Northing (m)	Or. Surf. EL (m amsl)	Meas. Pt. EL (m amsl)
Reference		Validation	

WELL LOG ENTRY FORM

Standard			
Well Lithology & Construction			
Identification		Type	Aquifer
Easting (m)	Northing (m)	Or. Surf. EL (m amsl)	Meas. Pt. EL (m amsl)
Drill. Dates		Drill. Method	
SWL (m amsl)	Specific Capacity	<div style="border: 1px solid black; padding: 2px; margin-bottom: 2px;">Vert. Scale</div> <div style="border: 1px solid black; padding: 2px;">Hor. Scale</div>	
Comments:			
Reference		Validation	

ADDITIONAL LITHOLOGY ENTRY FORM

Standard		
Additional Lithology Data Entry Form		
Well Ident		
Clay/Sand (m MSL)		
Sand/Limestone (m MSL)		
Limestone/Dolomite (m MSL)		
X	Y	Z
Type:		

STEP-DRAWDOWN TEST ENTRY FORM

Standard			
STEP DRAWDOWN TESTS			
Identification	Type	Aquifer	
	Easting (m)		Northing (m)
A	B	C	Depth (m)

PART TWO: REPORTING FORMS AND REPORTS

Well Ident	STIFF Diagram	
MW-5	Name	Type

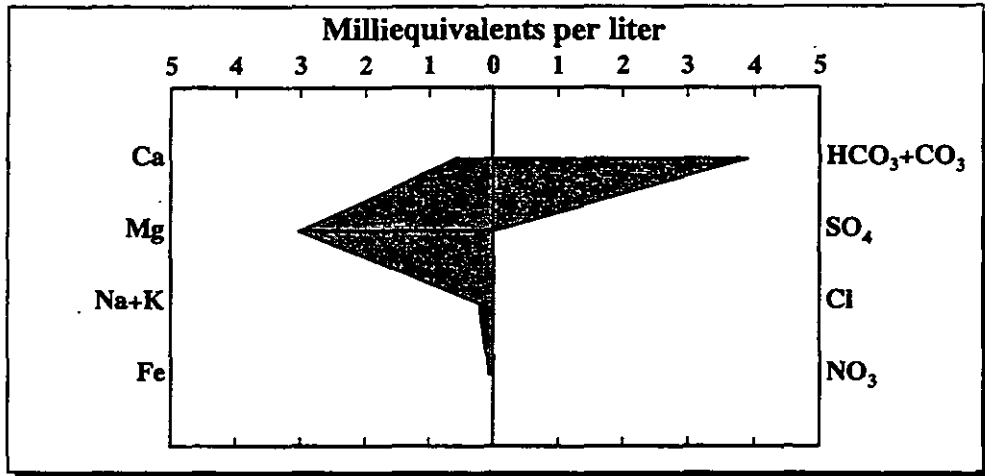

<i>Cations</i>					
	<i>Ca</i>	<i>Mg</i>	<i>Na</i>	<i>K</i>	<i>Fe</i>
<i>Milliequivalents per liter</i>	0.5998	3.0000	0.2001	0.01509	0.0645
<i>Milligrams per liter</i>	12.02	36.47	4.60	0.59	1.20

<i>Anions</i>					
	<i>HCO3</i>	<i>CO3</i>	<i>SO4</i>	<i>Cl</i>	<i>NO3</i>
<i>Milliequivalents per liter</i>	3.90000		0.01999	0.02003	0.00807
<i>Milligrams per liter</i>	237.95		0.96	0.71	0.50

BOD	COD	Diss. Oxygen	F	B	SiO2
TDS 229.00	Hardness	Alkalinity	Conductivity 270.00	pH 7.50	SAR 0.1491

Water Type	Cations (epm)
Magnesium Bicarbonate	3.88
Anions (epm)	Error Balance (%)
3.95	1.75
Aquifer	

CONCENTRATION - DEPTH SERIES

Well Ident
MW-1

Name
Monitoring well in Corozo Pando

Easting (X)
150

Northing (Y)
150

Ground Surf. Elev. (Z)
85.00

Meas. Point Elev. (Zm)
86.00

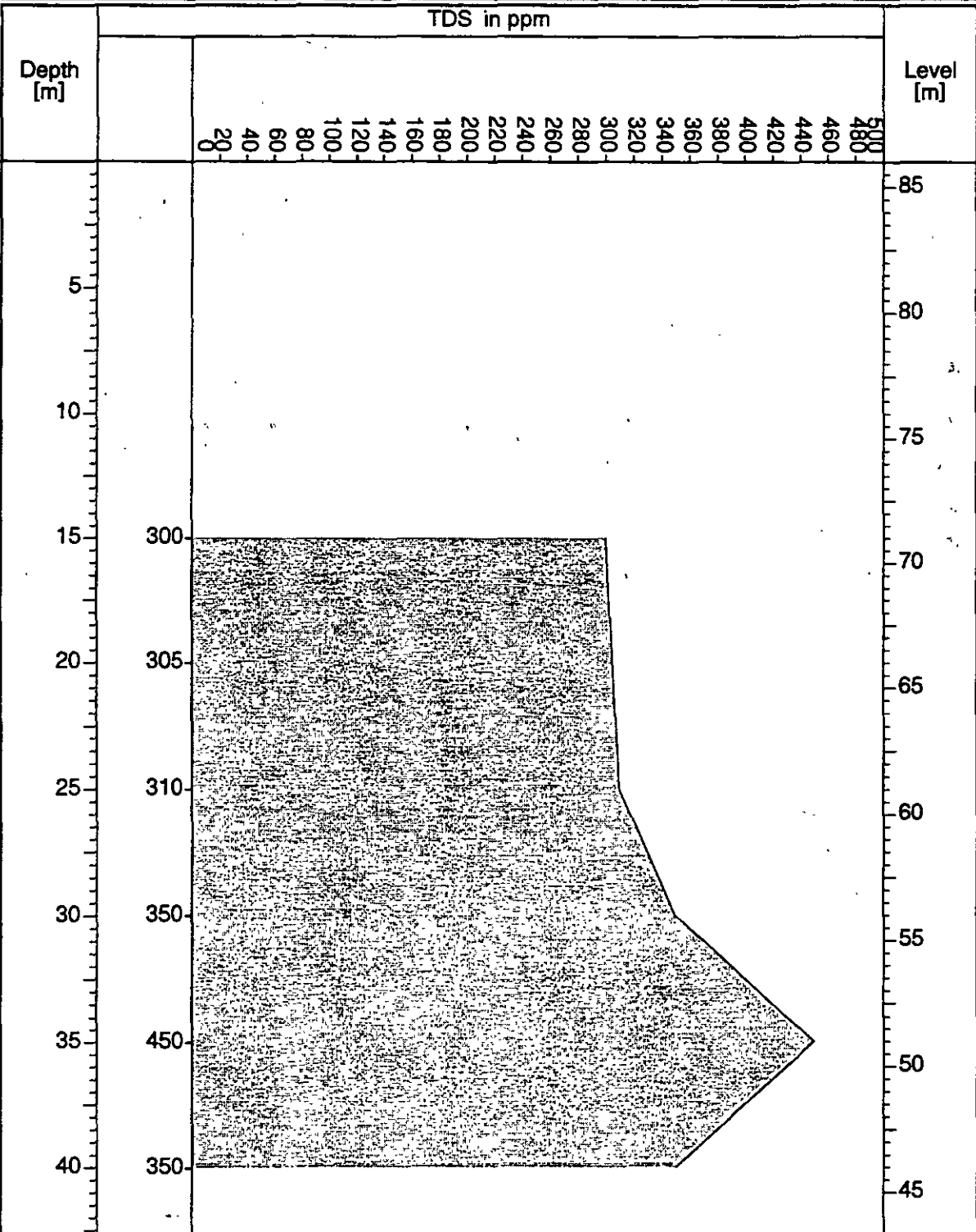

Schoeller Diagram

Schoeller Diagram

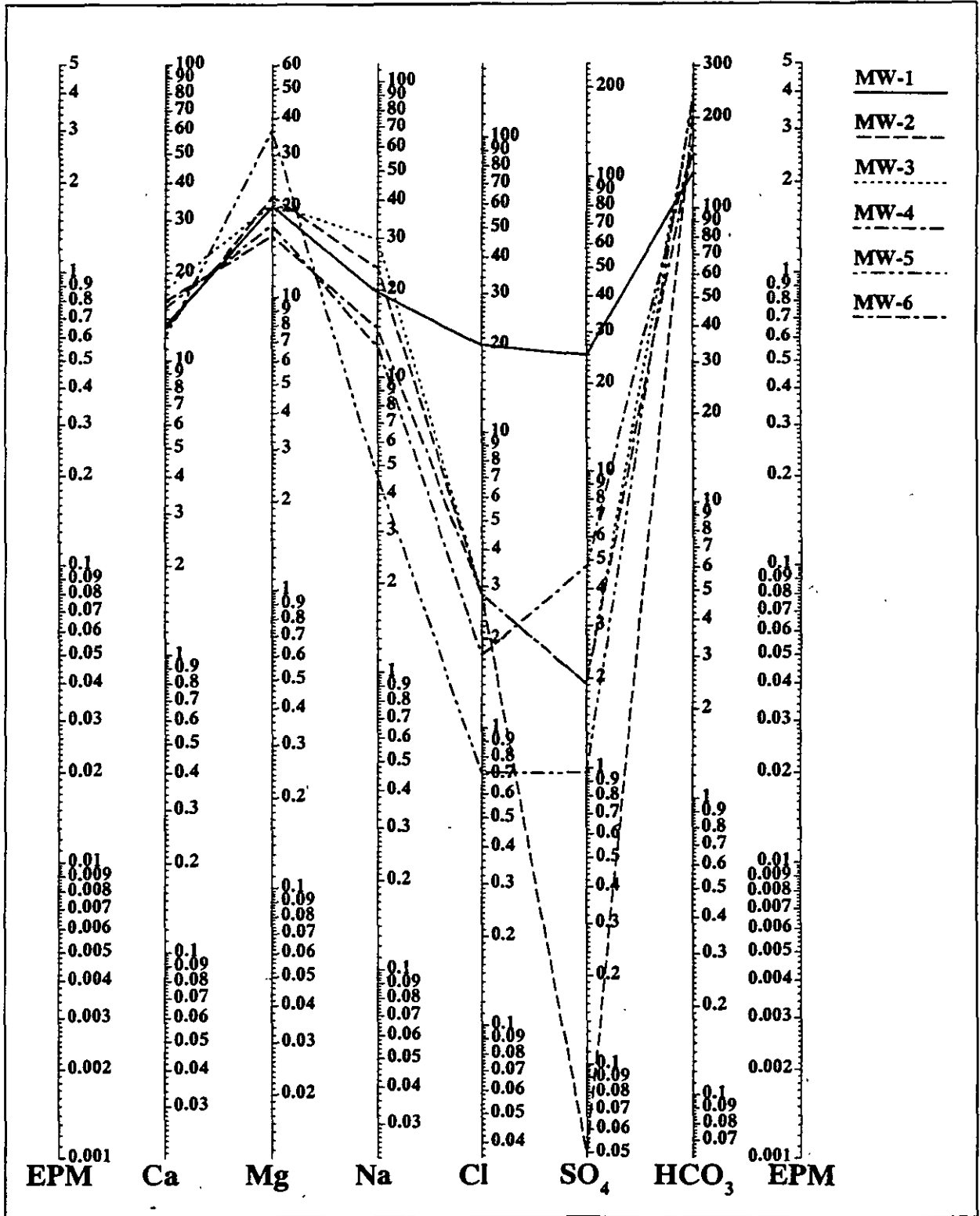

Piper Diagram

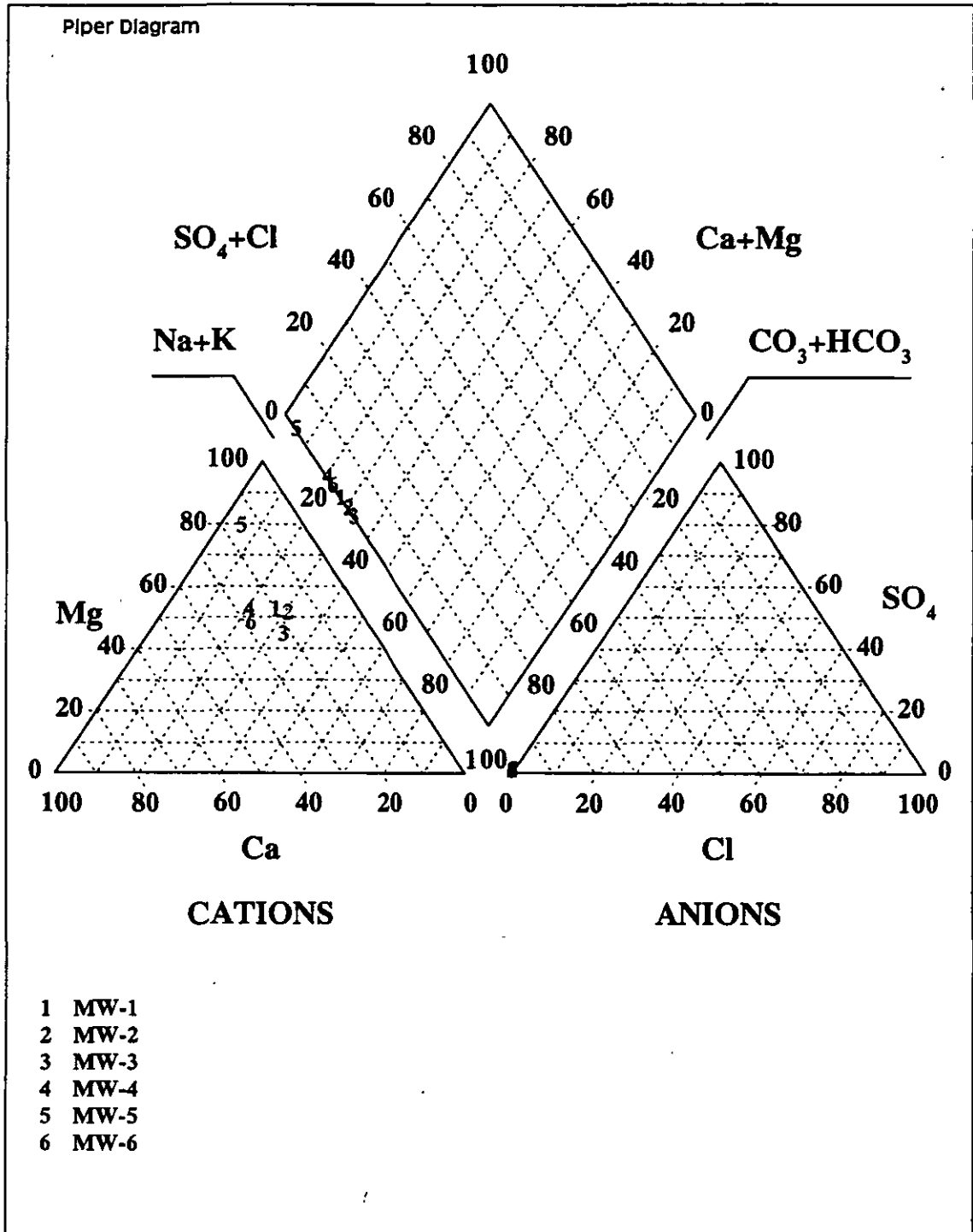

Wilcox Diagram

Wilcox Diagram

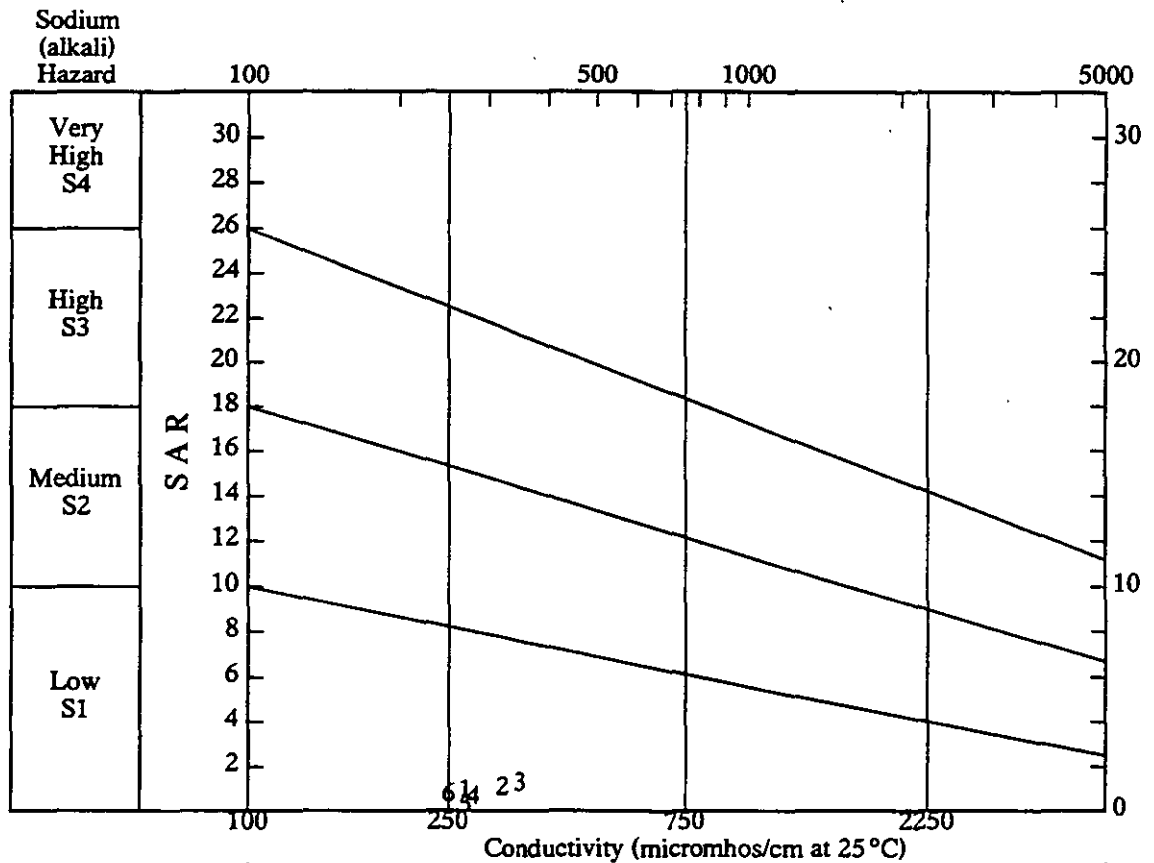

C1	C2	C3	C4
Low	Medium	High	Very High

Salinity Hazard

- 1 MW-1
- 2 MW-2
- 3 MW-3
- 4 MW-4
- 5 MW-5
- 6 MW-6

Chemical Data .. A Table .. Demo of the GWW Software

All constituents in ppm. Sums of anions and cations in epm. TDS in ppm. Conductivity in micromhos/cm at 25C

Well Ident	Ca	Mg	Na	K	Fe	Cations	HCO3	SO4	Cl	NO3	Anions	TDS	Conductivity
P-103	24.05	18.11	13.79	1.56		3.33	187.92	3.84	5.32		3.31	255.00	300.00
P-152	12.83	21.88	23.91	2.35		3.54	206.83	0.05	2.84		3.47	272.00	320.00
P-153	17.64	20.67	29.89	0.39		3.89	223.92	1.92	2.84		3.79	299.00	350.00
P-163	15.23	17.63	12.87	0.78		2.79	162.90	4.80	1.77		2.82	218.00	280.00
P-166	14.43	18.11	13.79	0.39		2.82	172.67	0.05	1.42		2.87	222.00	280.00
P-170	12.02	36.47	4.60	0.59	13.03	4.62	237.95	0.96	0.71	37.20	4.54	229.00	270.00
P-177	14.43	15.93	16.78	0.39		2.77	158.63	0.05	2.84		2.68	248.00	250.00
P-180	24.05	15.80	11.95	1.17		3.05	164.73	4.80	3.90		2.91	228.00	290.00
P-186	17.64	17.87	25.98	1.56		3.52	183.04	24.98	1.77		3.57	274.00	340.00
P-20	34.47	26.02	27.36	0.78		5.07	280.66	12.97	4.96		5.01	390.00	470.00
P-206	64.53	10.09	34.94	0.39		5.58	331.91	7.68	2.84		5.68	454.00	520.00
P-577	16.83	17.38	15.86	0.39		2.97	170.84	0.05	3.90		2.91	226.00	260.00
P-580	14.43	17.38	22.99	0.39		3.16	189.75	0.05	5.67		3.27	252.00	290.00
P-600	23.25	21.76	30.80	0.78		4.31	244.05	0.96	0.35		4.27	330.00	370.00
P-72	25.25	26.02	24.83	2.35		4.54	259.91	0.96	4.96		4.42	345.00	410.00
P-74	38.48	20.30	14.94	1.96		4.29	77.49	7.68	3.90		4.10	243.00	380.00
P-84	21.24	19.45	19.77	2.74		3.59	202.56	1.92	3.90		3.47	273.00	330.00
SRRG-19	10.02	10.94	213.79	1.17		10.73	430.75	0.96	66.64		10.39	780.00	950.00
SRRG-22	9.62	10.33	197.70	3.52		10.02	506.41	0.96	71.61		10.34	805.00	900.00
SRRG-38	10.02	8.27	43.68	4.30		3.19	152.53	24.98	5.67		3.18	254.00	290.00
SRRG-4	8.02	9.60	183.91	3.91		9.29	408.79	12.01	99.26		9.75	730.00	900.00
SRRG-7	4.41	1.95	2.30	2.35		0.54	25.63	1.92	1.77		0.51	42.00	45.00
SRRG-8	6.41	9.36	39.08	2.74		2.86	122.03	39.87	7.80		3.05	229.00	250.00

Chemistry Concentration / Time

Well Ident MW-1	Name Monitoring well in Corozo Pando	
Easting (m) 150	Northing (m) 150	Gr. Surf. Elev. (m amsl) 85.00

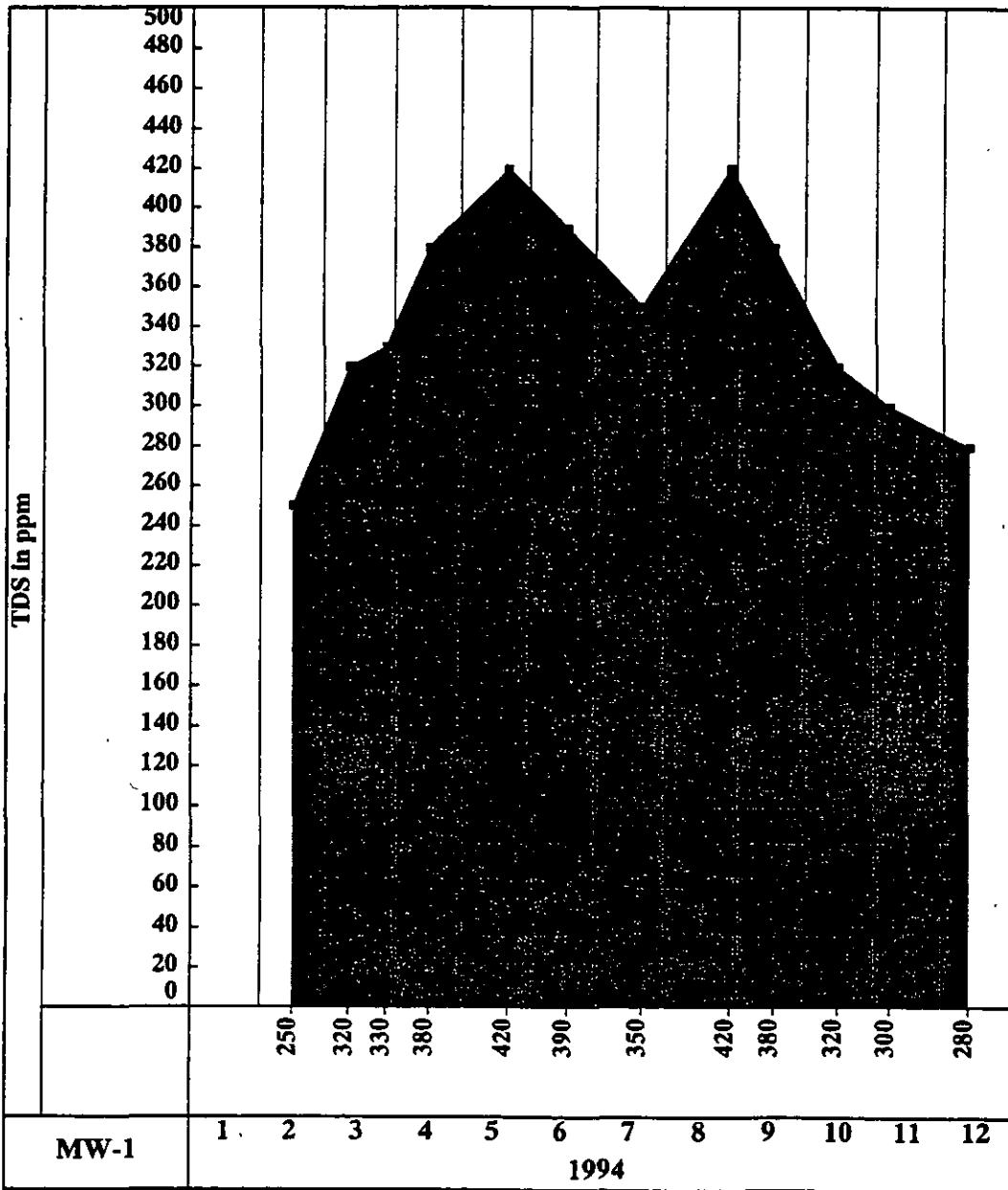

MW-1

1994

Well Log: Lithology & Construction

Well Ident MW-2	Name
---------------------------	-------------

Drill. Method Rotary with bentonite	Drill. Dates 15 to 22 March 1994
---	--

X 800	Y 250	Z 92.00	Meas. Pt. Elev. 93.00
-----------------	-----------------	-------------------	---------------------------------

All measurements are in meters. Hole and casing diameters in inches.

Scales (1:xxx)

Water Level (m AMSL) 88.20	Vertical	Horizontal 40.0
--------------------------------------	-----------------	---------------------------

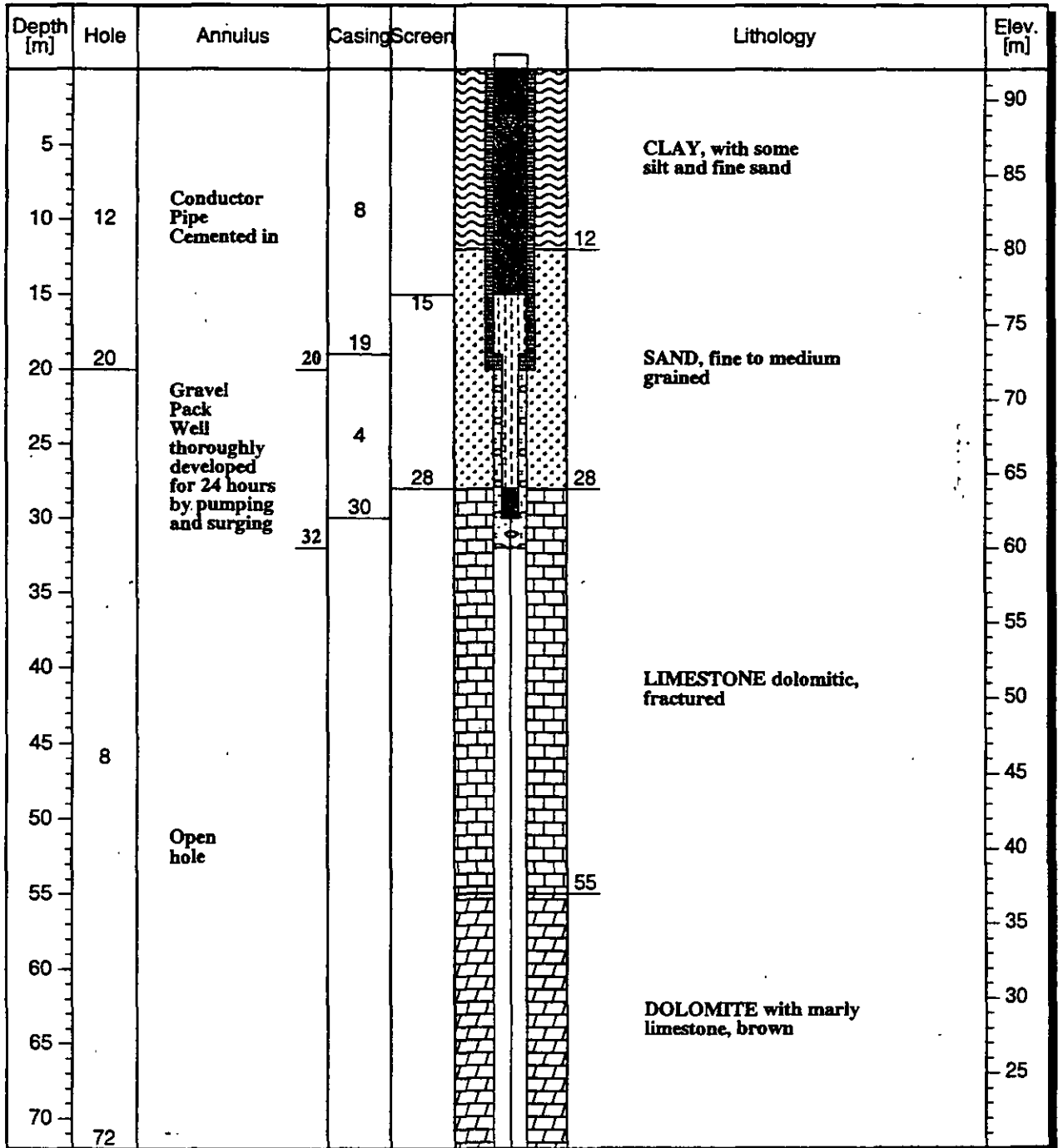

TESTE DE BOMBEAMENTO

POÇO G 1433 RM 1 P3	Município Flores da Cunha		
Dist. Poço Obs. [m] 6.00	Vazão Média [m3/h] 6.6667	Duração [min] 900.00	Espes. Sat. Inicial [m]

Resultados	Erro da Estimativa [m] 0.02
-------------------	---------------------------------------

Transmissividade [m2/h] 9.10	Coeficiente de Armazenamento 0.0097678	Gotejamento [1/day] 0.049710
--	--	--

Método	Método de Hantush
--------	--------------------------

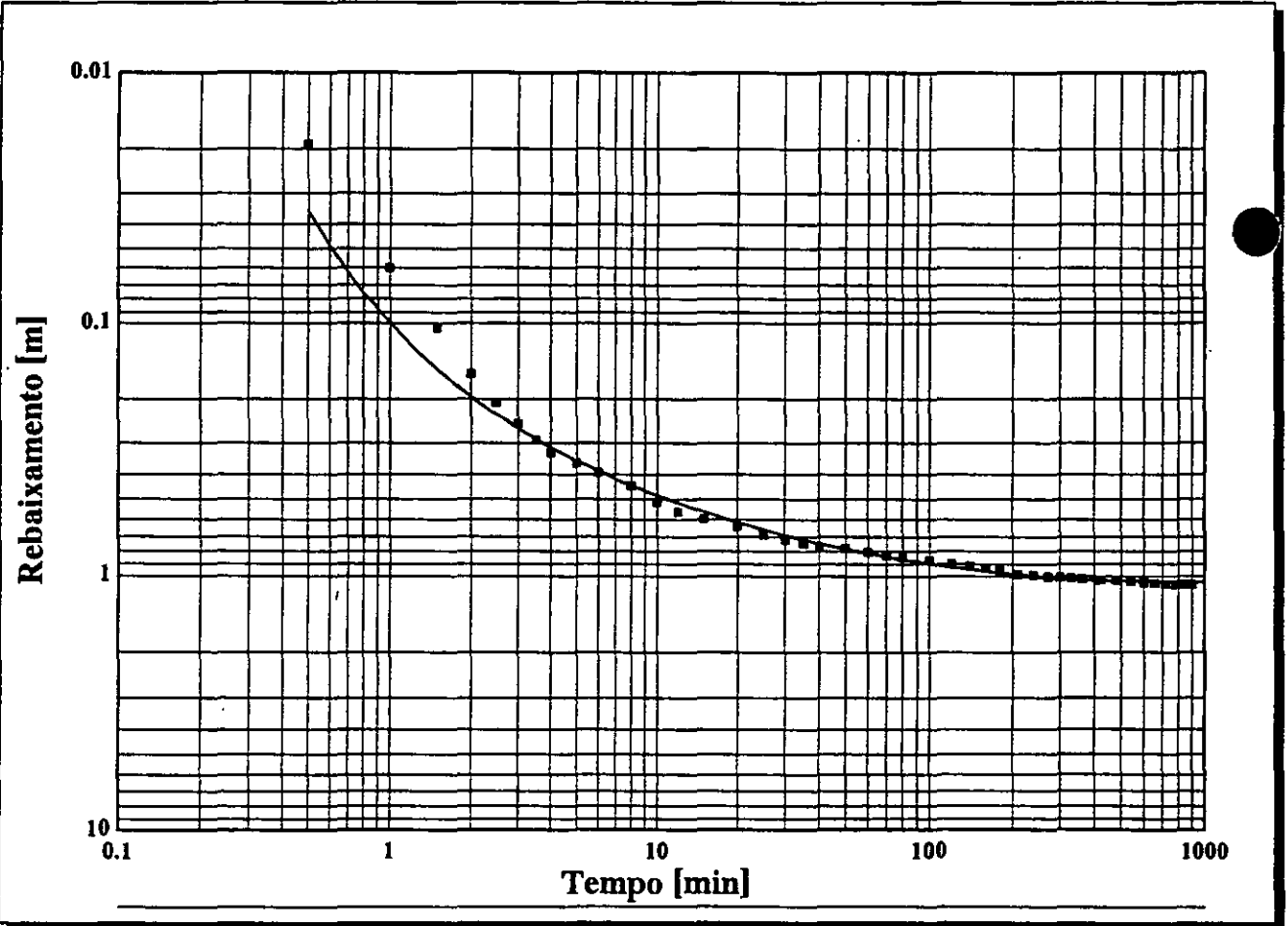

Pumping Test

Well Ident MW-2	Name		
Obs. Well Distance [m] 0.05	Average Pump. Rate [m3/day] 15.000	Duration [min] 1200.0	Initial Sat. Thickness [m]
<i>Results</i>			
Transmissivity [m2/day] 136	Storage Coefficient	Leakance [1/day]	Estimation Error [m] 0.10
Fit Method		Theis Method	

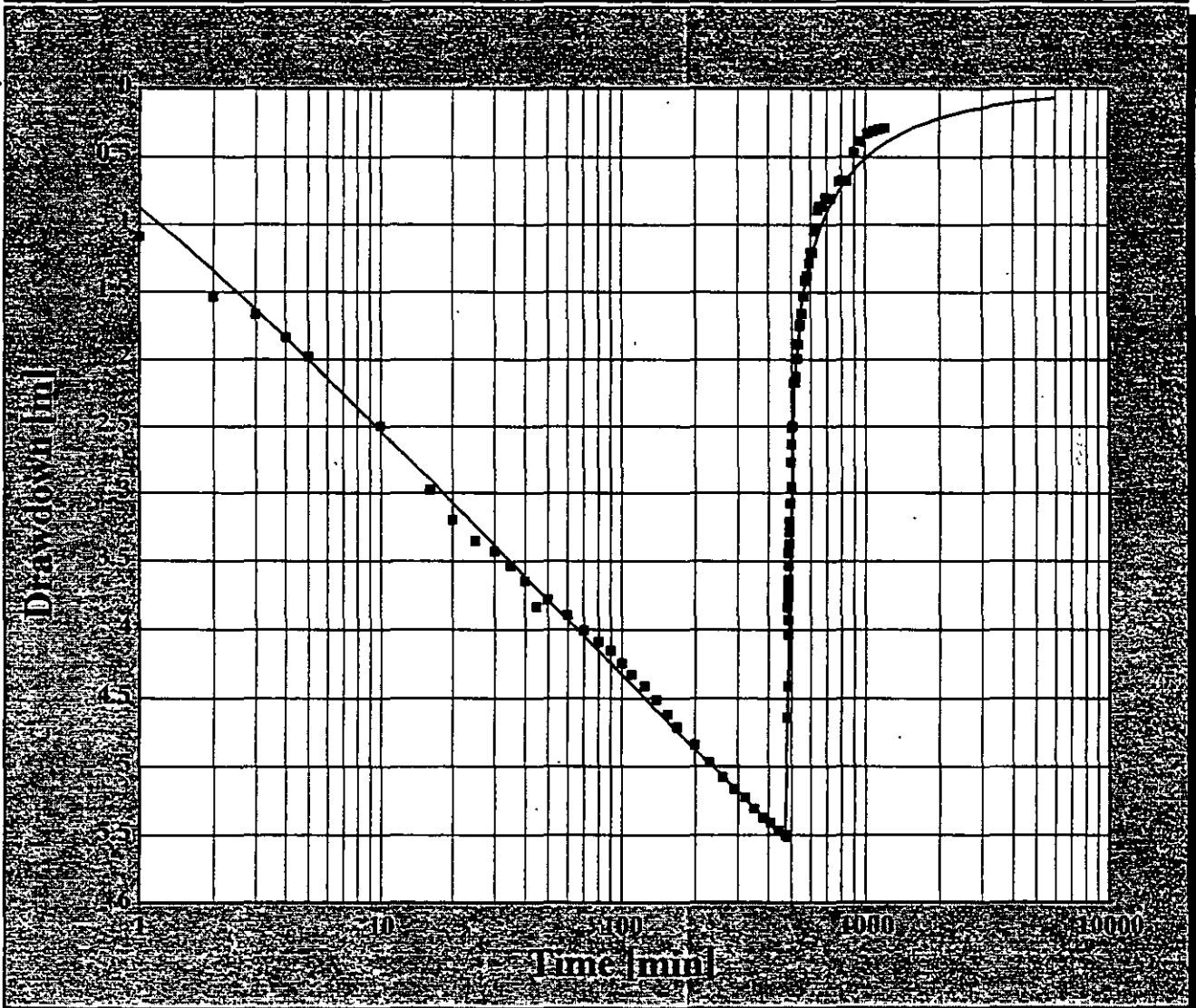

Well No.		Hydrograph Reporting Form	
A-0001		Description Observation well in St Johns District	
X	Y	Ground Surf. Elev.	Measuring Pt. Elev.
1235568	10781674	153.36	153.36
Aquifer		Quaternary	

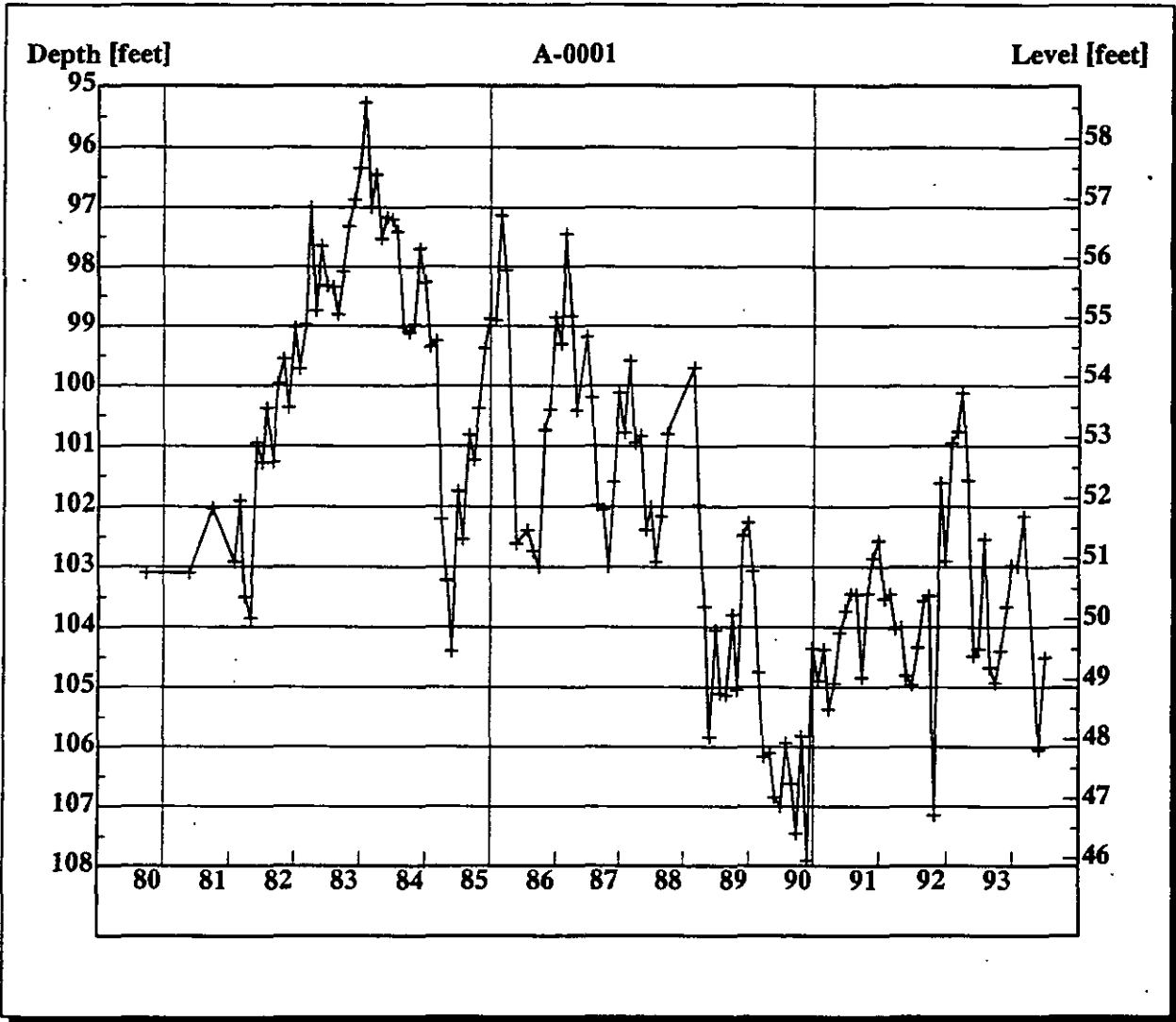

Grain Size Curve

Well Ident GSC-1	Description Monitoring Well, Landfill NN Project
----------------------------	--

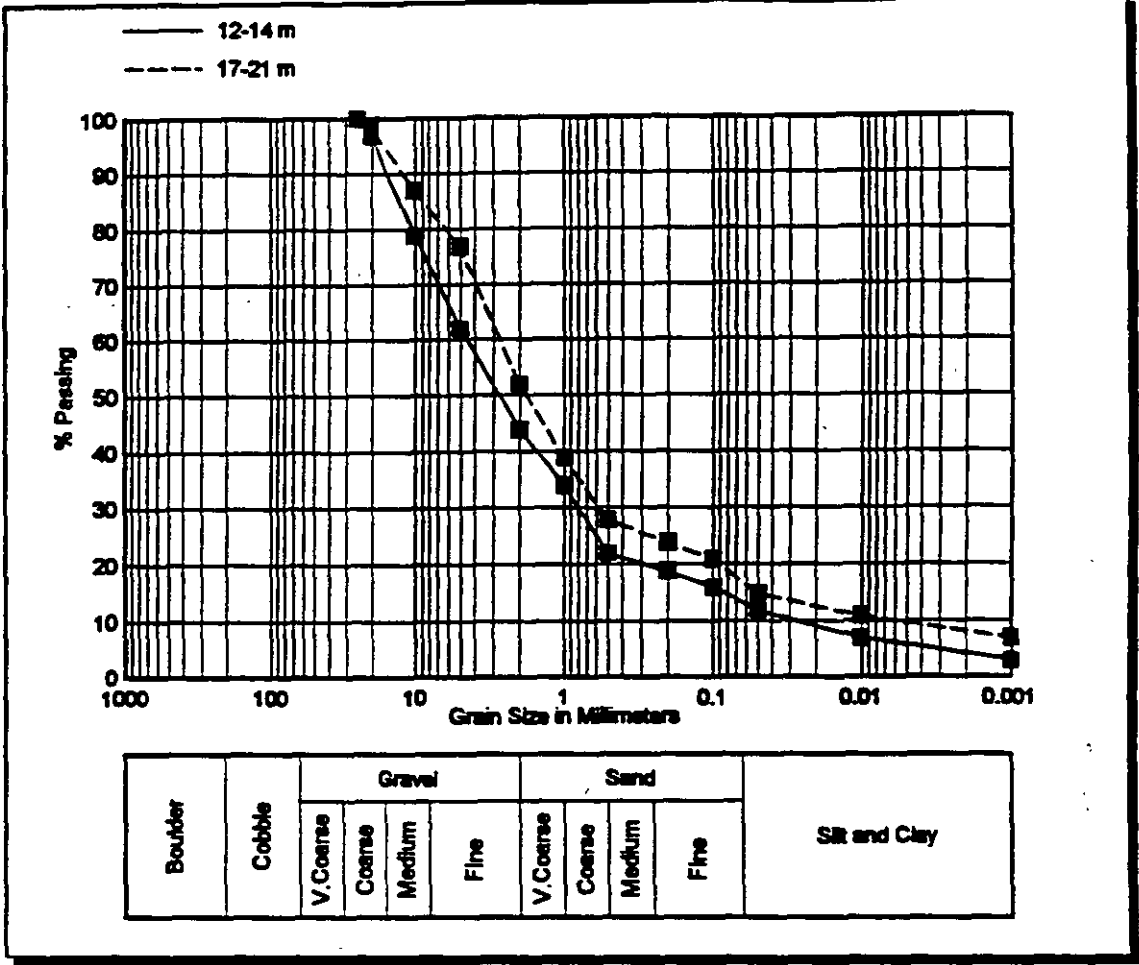

Sieve Sizes [mm]	12-14 m	17-21 m
0.001	3.00	7.00
0.010	7.00	11.00
0.050	12.00	15.00
0.100	16.00	21.00
0.200	19.00	24.00
0.500	22.00	28.00
1.000	34.00	38.00
2.000	44.00	52.00
5.000	62.00	77.00
10.000	79.00	87.00
20.000	97.00	98.00
25.000	100.00	100.00

A Landfill - Demo of the GWW Software

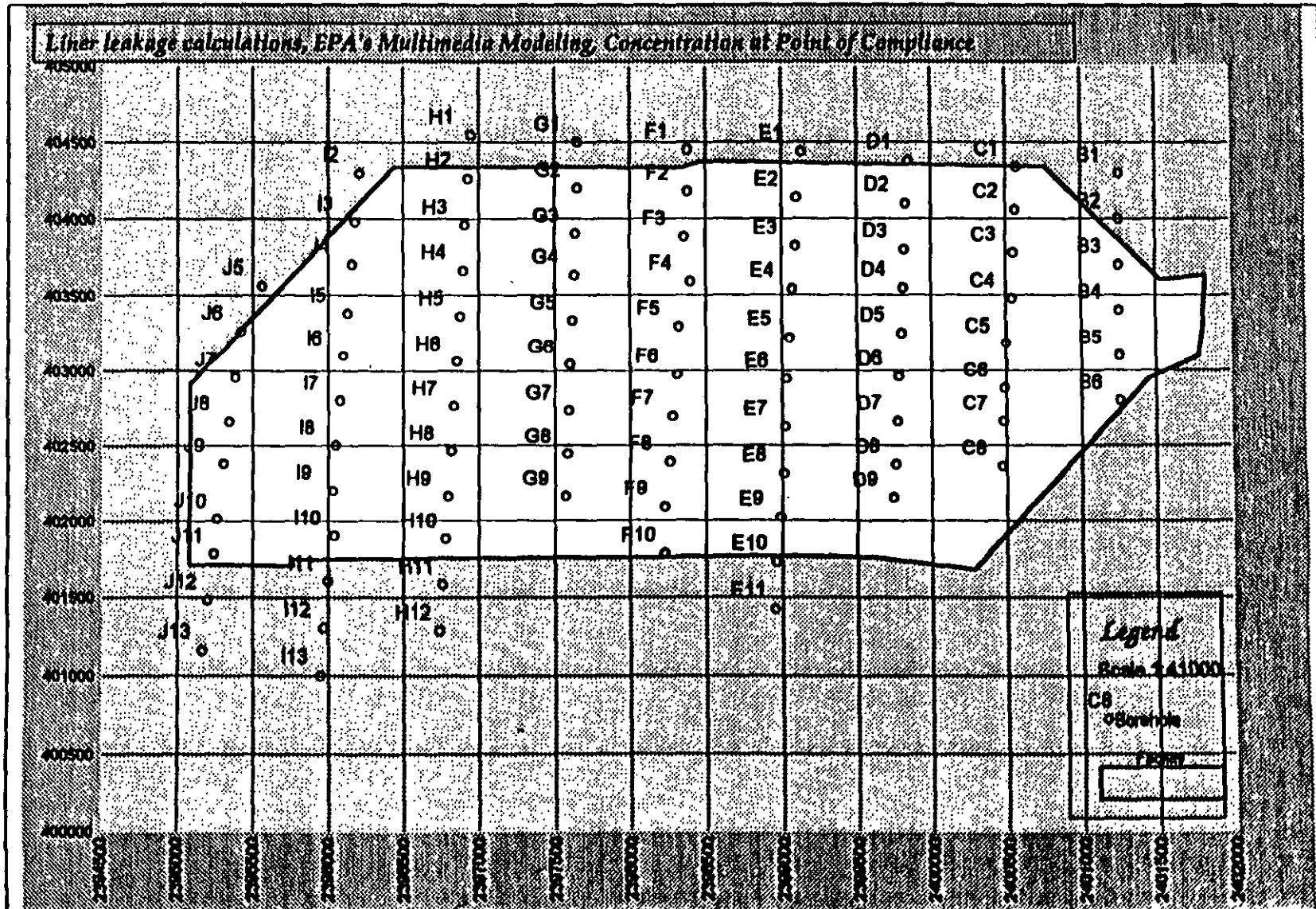

A Landfill - Demo of the GWW Software

Ground Water Contour Elevations (ft AMSL)

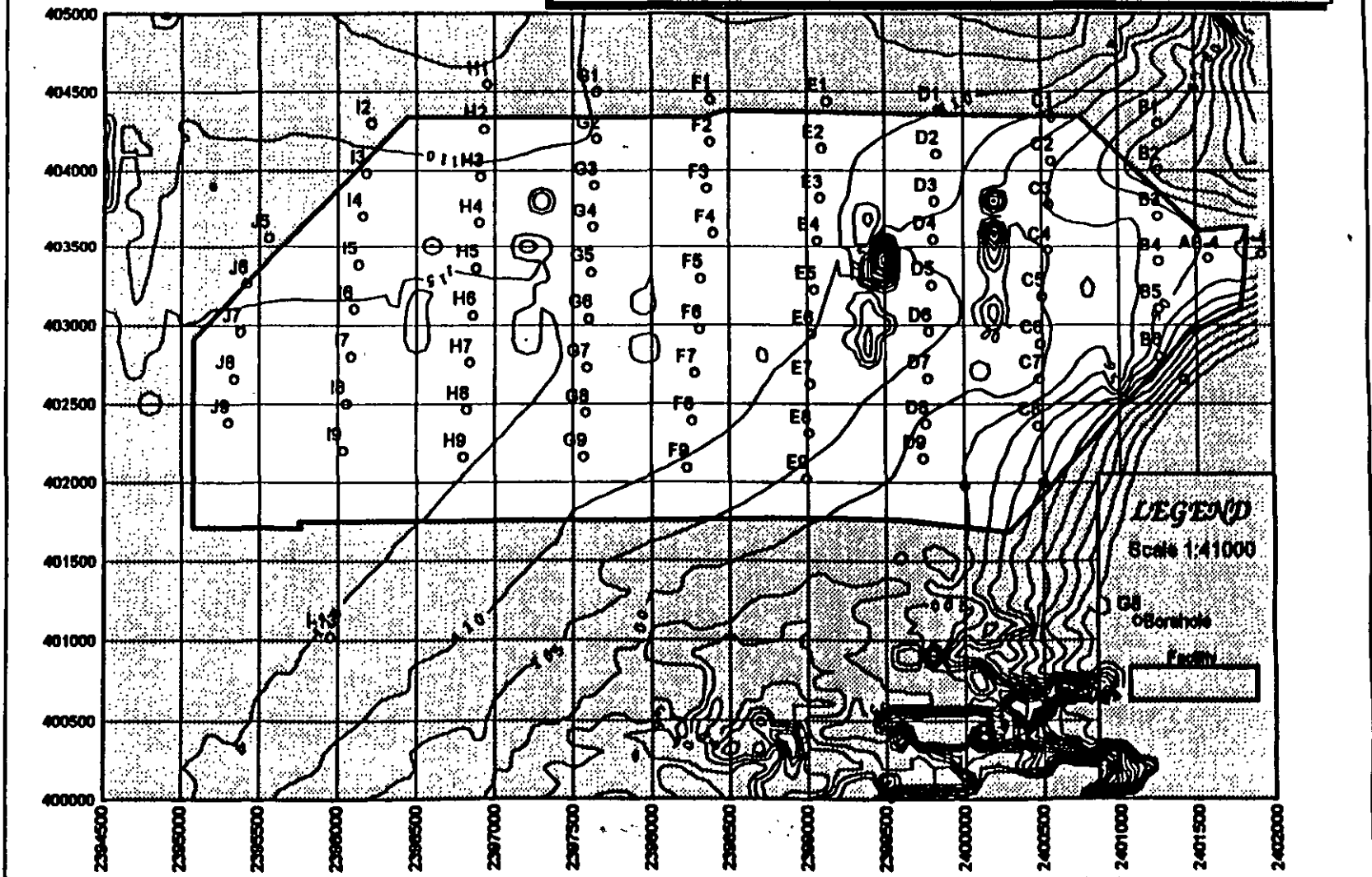

HYDROGEOLOGICAL CROSS SECTION A-A' ... Demo of GWW Software

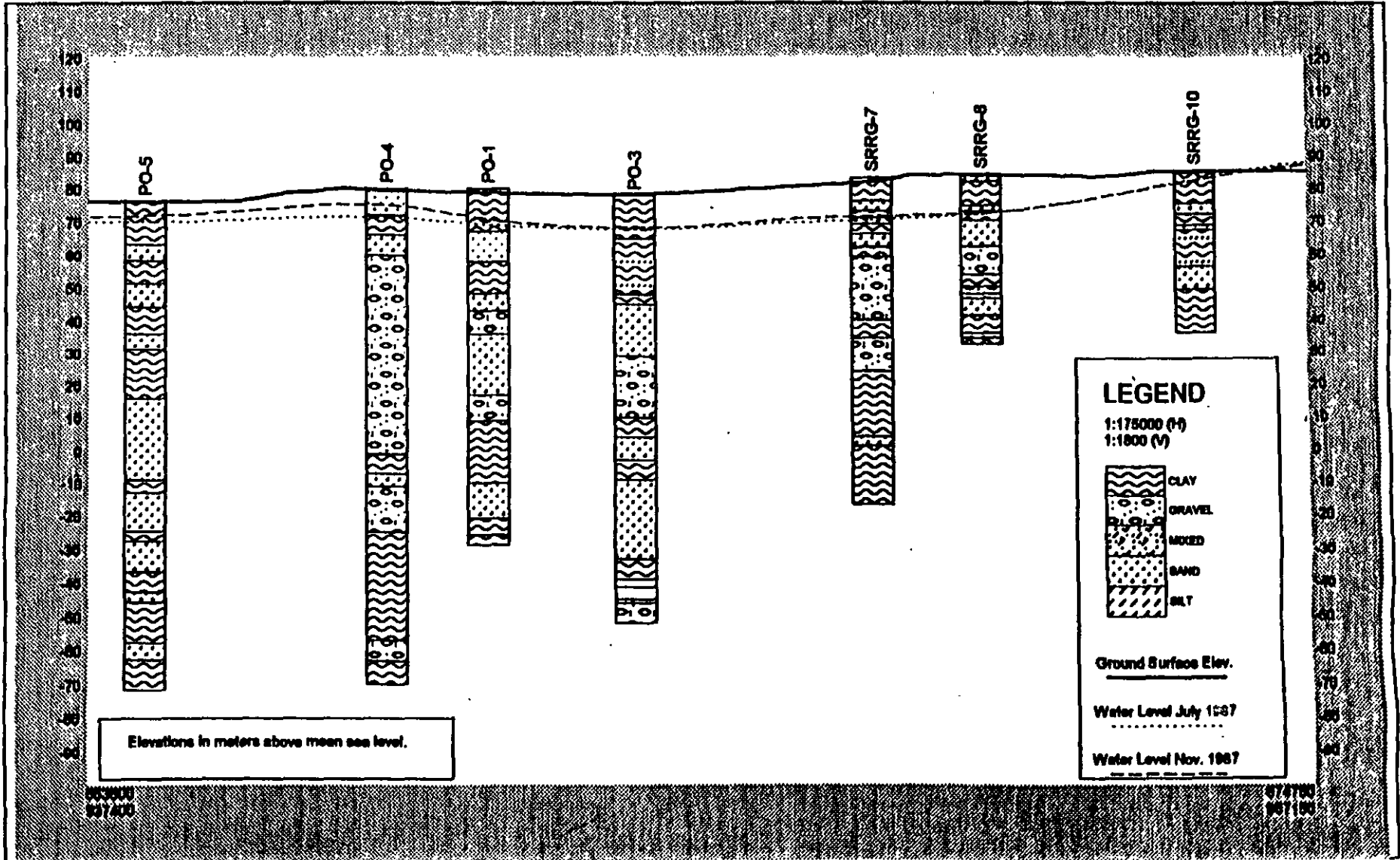

PART THREE:**ASCII FILE
FORM FOR
ADVANCED
USERS****Master File Entry
Form**

TEXT 'GWW Master Data' (130,30,1470,90) 2,15,20,20 P(0,0,0) B(191,0,0)
 'GWW Master Data' CC,0,0
 'Arial' 20,1,1,0 C(0,255,255)

DATA 'Well Ident' (120,160,270,110) 2,15,0,0 P(0,0,0) B(255,255,255)
 'Ident' 'LT,10,0
 'MS Sans Serif' 12,1,0,0 C(0,0,0)
 CB,10,-10
 'MS Sans Serif' 14,1,0,0 C(0,0,0)

DATA 'Description' (390,170,840,100) 2,15,0,0 P(0,0,0) B(255,255,255)
 'Description' 'LT,10,0
 'Helv' 8,0,0,0 C(0,0,0)
 CB,10,-10
 'Courier' 10,0,0,0 C(0,0,0)

DATA 'District' (1230,170,370,100) 2,15,0,0 P(0,0,0) B(255,255,255)
 'District' 'LT,10,0
 'Helv' 8,0,0,0 C(0,0,0)
 CB,10,-10
 'Courier' 10,0,0,0 C(0,0,0)

DATA 'Locality' (130,370,370,100) 2,15,0,0 P(0,0,0) B(255,255,255)
 'Locality' 'LT,10,0
 'Helv' 8,0,0,0 C(0,0,0)
 CB,10,-10
 'Courier' 10,0,0,0 C(0,0,0)

DATA 'Owner' (500,370,370,100) 2,15,0,0 P(0,0,0) B(255,255,255)
 'Owner' 'LT,10,0
 'Helv' 8,0,0,0 C(0,0,0)
 CB,10,-10
 'Courier' 10,0,0,0 C(0,0,0)

DATA 'Well Ident' (120,160,270,110) 6,15,0,0 P(0,0,0) B(255,255,255)
 'Ident' 'LT,10,0
 'MS Sans Serif' 12,1,0,0 C(0,0,0)
 CB,10,-10
 'MS Sans Serif' 14,1,0,0 C(0,0,0)

DATA 'Description' (390,170,840,100) 2,15,0,0 P(0,0,0) B(255,255,255)
 'Description' 'LT,10,0
 'Helv' 8,0,0,0 C(0,0,0)
 CB,10,-10

'Courier' 10,0,0,0 C(0,0,0)
DATA 'District' (1230,170,370,100) 2,15,0,0 P(0,0,0) B(255,255,255)
'District' 'LT,10,0
'Helv' 8,0,0,0 C(0,0,0)
CB,10,-10
'Courier' 10,0,0,0 C(0,0,0)
DATA 'Locality' (130,370,370,100) 2,15,0,0 P(0,0,0) B(255,255,255)
'Locality' 'LT,10,0
'Helv' 8,0,0,0 C(0,0,0)
CB,10,-10
'Courier' 10,0,0,0 C(0,0,0)
DATA 'Owner' (500,370,370,100) 2,15,0,0 P(0,0,0) B(255,255,255)
'Owner' 'LT,10,0
'Helv' 8,0,0,0 C(0,0,0)
CB,10,-10
'Courier' 10,0,0,0 C(0,0,0)
DATA 'X' (130,270,340,100) 2,15,0,0 P(0,0,0) B(255,255,255)
'Easting' 'LT,10,0
'Helv' 8,0,0,0 C(0,0,0)
CB,10,-10
'Courier' 10,0,0,0 C(0,0,0)
DATA 'Y' (470,270,360,100) 2,15,0,0 P(0,0,0) B(255,255,255)
'Northing' 'LT,10,0
'Helv' 8,0,0,0 C(0,0,0)
CB,10,-10
'Courier' 10,0,0,0 C(0,0,0)
DATA 'Z' (830,270,380,100) 2,15,0,0 P(0,0,0) B(255,255,255)
'Ground Surf. Elev.' 'LT,10,0
'Helv' 8,0,0,0 C(0,0,0)
CB,10,-10
'Courier' 10,0,0,0 C(0,0,0)
DATA 'ZM' (1210,270,390,100) 2,15,0,0 P(0,0,0) B(255,255,255)
'Measur. Pt. Elev.' 'LT,10,0
'Helv' 8,0,0,0 C(0,0,0)
CB,10,-10
'Courier' 10,0,0,0 C(0,0,0)
DATA 'Map Sheet No.' (1280,370,320,100) 2,15,0,0 P(0,0,0) B(255,255,255)
'Map Sheet No.' 'LT,10,0
'Helv' 8,0,0,0 C(0,0,0)
CB,10,-10
'Courier' 10,0,0,0 C(0,0,0)

Example of an input
text block in the
Master File Entry
Form:

```
DATA 'Well Ident  
(120,160,270,110) 2,15,0,0 P(0,0,0)  
B(255,255,255)
```

```
Ident 'LT,10,0
```

```
'MS Sans Serif' 12,1,0,0 C(0,0,0)
```

```
CB,10,-10
```

```
'MS Sans Serif' 14,1,0,0 C(0,0,0)
```

The page origin is in the upper left corner. All measures refer to the upper left corner.

First box: Field Name is Well Ident. The field starts at 120 mm from the left margin upper corner of the page (X=120), and at 160 mm from the top margin (Y=160). The horizontal length of the field is 270 mm and its height is 110 mm.

The numbers 2 and 15 represent the frame line thickness (in 10th of a millimeter) and a parameter indicating whether this is a full frame around the field or a partial frame (with one, two or three lines), respectively.

The numbers 0,0 indicate that there is no border enhancing the field. The following numbers define the border: 0 - no border; 10 - 1 mm border line; 20 - 2 mm border line, etc. If the number is negative the line is to the left or below. If it is positive the line is to the right or above.

The block P(0,0,0) is of no concern. It defines the color of the label, but this is overridden by another block on line 3.

The block B(255,255,255) sets the color for background. This combination is for no color, or white background. The sequence is red, green, and blue, or RGB.

Second box: 'Ident' is the label that will be displayed and printed. Notice that Field Name and Label name do not need to be the same. Field Name must appear exactly as it is entered into the Data File Structure, but you may type anything to Label Name.

The letters LT indicate the horizontal and vertical alignment, respectively. The letters have the following meaning:

- L = left
- C = center
- R = right

- T = top
- B = bottom

In this example the word Ident will start at the left edge of the field in the upper one third of the field.

The numbers 10,0 after LT indicate horizontal and vertical offsets in X direction (10 tenths of a millimeter), and 0 in Y direction.

Third box: 'MS Sans Serif' is the font family used to write the label 'Ident'. The four numbers after the font family define the following:

- font size
- bold (1), normal (0)
- italic (1), not italic (0)
- underlined (1), not underlined (0)

In this case, the font size is 12 points, 'Ident' will be displayed and printed as boldface, no italics, no underlining.

The block C(0,0,0) indicates color for the label. Three zeros mean black, three 255s would mean white. Any other combination would imply one of more than 16 million colors.

Fourth box: it defines the position and offsets for data to fill the field. CB stands for center (horizontally), and bottom (vertically). 10,-10 means horizontal offset 10 tenths of a millimeter (one mm to the right), and -1 mm above the bottom.

Fifth box: same as box three, but this box refers to data. Font family is again 'MS Sans Serif', font size is 14 points. Data will be printed bold, no italics, no underlining. Its color will be black.

Text fields differ from **Data fields** in the following. They have only three lines of definition. The fourth and fifth lines, which define the data filling the field, have no meaning here.

APPENDIX D ... VARIOUS ASCII FILES ... PROGRAM'S DEFAULT AND EXAMPLES

GWW.UNT

Units, type of units, and
conversion factors.
First line (header) is not
a part of the file.

Data Type	Unit	Conversion Factor
Length	m	1.000000E 00
Length	cm	1.000000E-02
Length	mm	1.000000E-03
Length	inch	2.540000E-02
Length	feet	3.0487800E-01
Length	yard	9.1440000E-01
Length	mile	1.6090000E 03
Length	Km	1.000000E 03
Time	sec	1.000000E 00
Time	min	6.000000E 01
Time	hr	1.440000E 03
Time	day	8.640000E 04
Volume	m3	1.000000E 00
Volume	l	1.000000E-03
Volume	cm3	1.000000E-06
Volume	quart	9.4760000E-04
Volume	barrel	1.5900000E-01
Volume	acre-ft	1.2340000E 03
Volume	gallon	3.7850000E-03
Volume	ft3	2.8299688E-02
Area	m2	1.000000E 00
Area	ha	1.000000E 04
Area	ft2	9.2902260E-02
Area	acre	4.0470000E 03
Area	Donum	1.000000E 03
Flowrate	m3/s	1.000000E 00
Flowrate	l/s	1.000000E-03
Flowrate	gpm	6.3090000E-05
Flowrate	g(UK)pm	7.5770000E-05
Flowrate	acre-ft/d	1.4580000E-04
Flowrate	m3/day	1.1500000E-05
Velocity	m/sec	1.000000E 00
Velocity	cm/sec	1.000000E-02
Velocity	m/d	1.1500000E-05
Velocity	m/yr	4.1975000E-03
Velocity	m3/s/acre	3.2708762E 01

Velocity	gpd	1.4326438E-06
Velocity	ft/sec	3.0480000E-01
Transmissivity	m ² /s	1.0000000E 00
Transmissivity	m ² /day	1.1157400E-05
Transmissivity	gpd/ft	1.3857491E-07
Transmissivity	g(UK)pd/ft	1.6646841E-07
Transmissivity	ft ² /min	1.4860773E-03
Permeability	m/s	1.0000000E 00
Permeability	m/day	1.1574000E-05
Permeability	cm/s	1.0000000E-02
Permeability	gal/day/ft ²	4.7160000E-07
Permeability	ft/s	3.4800000E-02
Permeability	ft/day	4.0277520E-07
Pressure	Pascal	1.0000000E 00
Pressure	pounds/sq.in.	6.8950000E 03
Pressure	lb/sq	1.0000000E 00
Pressure	atmosphere	1.0130000E 05
Pressure	millibar	1.0000000E 02
Pressure	kg/m.s ²	1.0000000E 00
Temperature	Celsius	1.0000000E 00
Energy	joule	1.0000000E 00
Energy	ft-lb	1.3560000E 00
Energy	ft-poundal	4.2140000E-02
Energy	BTU	1.0550000E-03
Energy	calorie	4.1870000E 00
Energy	kg.m ² /s ²	1.0000000E 00
Force	newton	1.0000000E 00
Force	pound(f)	4.4480000E 00
Leakance	1/s	1.0000000E 00
Leakance	1/min	1.6666666E-02
Leakance	1/day	1.1574070E-05
SpecCapacity	m ³ /s/m	1.0000000E 00
SpecCapacity	l/s/m	1.0000000E-03
SpecCapacity	m ³ /d/m	1.1157400E-05

PPMTOEPM.TBL

The first line (header)
is not a part of the file.

Constituent	Conversion Factor
Ca	0.04990
Mg	0.08226
Na	0.04350
K	0.02557
Fe	0.05372
Mn	0.03640
HCO3	0.01639
CO3	0.03333
SO4	0.02082
Cl	0.02821
NO3	0.01613
NO	0.02174
PO4	0.03159
SiO2	0.27750
Sr	0.02283
Zn	0.03060
Al	0.11119
NH4	0.05544
Ba	0.01456
Be	0.33288
Br	0.01251
Cd	0.01779
Co	0.03394
Cu	0.03148
F	0.05264
H	0.99209
OH	0.05880
I	0.00788
Li	0.14411
Rb	0.01170

GUARICO

**Example of a line file
(a river). The first line
(header) is not a part
of the file.**

X Coordinate	Y Coordinate
672327.6870000	970824.2500000
672175.6870000	970572.2500000
672210.6870000	970399.2500000
672457.6870000	970604.2500000
672540.6870000	970307.2500000
672367.6870000	969797.2500000
672282.6870000	969622.2500000
672537.6870000	969119.2500000
672610.6870000	969004.2500000
672987.6870000	969432.2500000
673195.6870000	969052.2500000
673057.6870000	968689.2500000
673247.6870000	968517.2500000
673535.6870000	968509.2500000
673897.6870000	968989.2500000
674237.6870000	968362.2500000
674337.6870000	967899.2500000
674067.6870000	967649.2500000
673997.6870000	967559.2500000
673870.6870000	967364.2500000
673510.6870000	967297.2500000
673117.6870000	967222.2500000
672930.6870000	967219.2500000
673002.6870000	967437.2500000
673177.6870000	967689.2500000
673017.6870000	967897.2500000
672712.6870000	967592.2500000
672515.6870000	967367.2500000
672575.6870000	967012.2500000
672857.6870000	966774.2500000
673002.6870000	966592.2500000
673257.6870000	966827.2500000
673462.6870000	966687.2500000
673205.6870000	966262.2500000
673342.6870000	965977.2500000
673570.6870000	965744.2500000

673682.68700000	966107.25000000
673670.68700000	966444.25000000
673920.68700000	966294.25000000
673747.68700000	965404.25000000
673130.68700000	965314.25000000
673295.68700000	965077.25000000
673377.68700000	964637.25000000
673372.68700000	964417.25000000
673152.68700000	964372.25000000
673155.68700000	963887.25000000
673862.68700000	963927.25000000

RANDOM DATA FILE EXAMPLE

The first line
(header) is not a
part of the file.

X Coordinate	Y Coordinate	Z Coordinate	Well Ident.
665000.0	958000.0	83.31000	El_Frio
659000.0	959900.0	83.90000	P-184
643300.0	965700.0	81.82000	P-540
639300.0	965700.0	81.50000	P-543
657900.0	949000.0	80.00000	PO-1
660000.0	953500.0	79.00000	PO-2
663600.0	950300.0	78.00000	PO-3
657800.0	945300.0	80.00000	PO-4
654863.0	938521.0	76.30000	PO-5
675800.0	962300.0	85.50000	SRRG-10
668100.0	954200.0	82.50000	SRRG-11
657700.0	964800.0	85.20000	SRRG-15
645300.0	955000.0	77.70000	SRRG-18
640700.0	961600.0	79.65000	SRRG-21
651500.0	955800.0	81.50000	SRRG-24
653200.0	966400.0	87.05000	SRRG-28
657800.0	967800.0	83.25000	SRRG-3
662200.0	967700.0	89.40000	SRRG-4
632600.0	959000.0	75.00000	SRRG-40
662400.0	967000.0	85.00000	SRRG-5
665000.0	958000.0	83.31000	SRRG-7

669000.0	959200.0	84.35000	SRRG-8
661100.0	966800.0	89.15000	SRRG-9

**PUMPING TEST
DATA FILE -
RECOVERY**

The first line must contain 0 for the time, 0 for the drawdown, and the pumping rate.

The second line must contain the total pumping phase time, the total drawdown at the moment when the pump was shut off, and 0 for the pumping rate. Zeros for the pumping rate need not be typed after the second line.

Time (min)	Residual Drawdown (m)	Pumping Rate (m ³ /day)
0.00	0.0000	2500.0000
240.00	1.0000	0.0000
241.00	0.8900	0.0000
242.00	0.8100	0.0000
243.00	0.7600	0.0000
245.00	0.6800	0.0000
247.00	0.6400	0.0000
250.00	0.5600	0.0000
255.00	0.4900	0.0000
260.00	0.4500	0.0000
270.00	0.3800	0.0000
280.00	0.3400	0.0000
300.00	0.2800	0.0000
320.00	0.2400	0.0000
340.00	0.2100	0.0000
380.00	0.1700	0.0000
420.00	0.1400	0.0000

Master Data Input/Output File as produced by the Master Application's option Write to STD ASCII Output.

```

<Well Ident> <Description> <District> <Locality> <Owner> <X> <Y> <Z> <ZM> <Date of Construction> <Type of Explanation:>
<Investigation by:> <Drilled by:> <Comment:> <Surveyed by:>
B-1 _____ 1246.00
920.00      100.00      -      4/2/90      Soil_test_boring      Dames_&_Moore      D&G_Drilling_of_New_Lenox_IL_
B-2 _____ 1240.00
937.00      100.00      -      4/2/90      Soil_test_boring      Dames_&_Moore      D&G_Drilling_of_New_Lenox_IL_

```

The important things to remember when creating such a file using a text processor are the following:

1. The top lines (one or more) of the file, the "header" lines, must contain field names within square brackets.
2. The sequence of field names is not important, but it must be consistent with the data columns that follow.
3. The field names must be typed exactly the same as they are entered into the file structure for that particular application. This means the spelling must be correct and upper and lower case rule must be honored.
4. The data lines must contain an equal number of data columns as specified in the header line(s).
5. The length of data columns depends on the type of data. For character type the data column should consist of exactly the same number of characters as specified in the file structure. E.g., if the field name "Investigation by" is specified as a field of 20 characters, the data column must have exactly 20 characters. Add the character underline () to fill the field. In the example above, the field for "Investigation by:" is typed as Dames_&_Moore, making it 20 characters long. For numeric values the length of the field is not important as long as there is at least one blank field before and after the numeric value. If there is no data (value) for a parameter you should type one underlined () character instead of the value.
6. In character-defined field names, such as Investigation by:, if there is more than one word, the words must be connected with one or more underlined () characters. In other words, GWW interprets a blank space as the end of the previous field and beginning of the next field.
7. The number of characters that you may use in defining a field name is limited to 20. For this reason, in the chemistry file which follows, the word Fluorotrichloromethane was reduced to Fluorotrichloromet.

Chemical Data Input/Output as produced by the Chemical Application's optic Write to STD ASCII Output.

```

<Well Ident> <Date Chem> <Soil/Water> <Copper> <Mercury> <Nickel> <Zinc> <Arsenic> <Beryllium> <Cadmium> <Chromium>
<Lead> <Selenium> <1,1,1-Trichloroethane> <1,1,2-Trichloroethane> <1,1-Dichloroethane> <1,2-Dichloroethane> <1,2-Dichloroethane>
<1,2-Dichloroethane> <Chloroform> <Toluene> <2-Methoxy-2-methylpr> <1-(2-Methoxypropoxy)> <1-(2-Methoxy-1-methyl)>
<Hexamethylphosphoril.> <Hexadecanethylopta.> <Dodecanoic acid> <N-Methyl-N-glycine> <Tetradecanethylocta.> <Benzene> <Ethylbenzene>
<Chloroethane> <Tetrahydrofuran> <Methylzinc Chloride> <Trichloroethane> <Xylene> <Acetone> <MethylEthylKetone> <2-Hexanone>
<Carbon Disulfide> <4-Methyl-2-Penta> <Tetrachloroethane> <Vinyl Chloride> <Phenotrithloroacet> <Hexane> <Cyclohexane>
<MethylCyclopentane> <3-Methyl-Pentane> <Cyclopentane> <2-MethylPentane> <Hydrocarbon C7H14> <Methyl Cyclohexane> <3-Methyl
Hexane> <2-Methyl Hexane> <Hydrocarbon C6H12> <2,3-DimethylButane> <Description> <District> <Locality> <Owner> <X> <Y> <Z>
<ZM> <Date of Construction> <Type of Explosion:> <Investigation by:> <Drilled by:> <Comment:> <Surveyed by:>
B-1 APR. 1990 19000.000 3000.000
          3100.000
          1346.00
920.00 100.00 4/2/90 Soil test boring Dumas & Moore D&G Drilling of New Lanox, IL
B-2 APR. 1990 87000.000 1800.000 2500.000
          1340.00
937.00 100.00 4/2/90 Soil test boring Dumas & Moore D&G Drilling of New Lanox, IL
          David H.Will & Associates
    
```

Lithologic Data Input/Output as produced by the Chemical Application's option Write to STD ASCII Output.

```

WELL: SRRG-9
X: 661100.00
Y: 966800.00
ELEV: 86.00
ELEVH: 87.00
CBLOCKDX: 0.50
CBLOCKDY: 0.50
CBLOCKH: 0.40
VSCALE: 135.0
HSCALE: 12.5
LITH:
14.800 CLAY
17.000 SAND
20.600 GRAVEL
24.200 CLAY
41.400 GRAVEL
41.700 CLAY
HOLE:
10.000 0.500
24.200 0.300
41.700 0.200
CASING:
10.000 0.400
24.200 0.200
41.700 0.100
SCREEN:
14.800 20.600
30.000 40.000
ANNULUS:
10.000 CEMENT
41.700 GWS
    
```

In this file you may not change the labels on the left side ending with the colon. You may change the alignment of numeric values, that is the number of blank spaces. The codes under entries LITH: and ANNULUS: must be consistent with codes contained in the .DLT files that you intend to use in the data base.

Pumping test ASCII file contains only the time/drawdown/pumping rate data. Other information about a test you must input manually (distance to the observation well, type of aquifer, partial penetration parameters, etc.). One example is reproduced below.

3.00	0.2980	220.0000
5.00	0.6990	220.0000
8.00	1.2990	220.0000
12.00	2.0990	220.0000
20.00	3.2010	220.0000
24.00	3.6010	220.0000
30.00	4.1000	220.0000
38.00	4.7000	220.0000
47.00	5.1000	220.0000
50.00	5.3000	220.0000
60.00	5.7010	220.0000
70.00	6.1010	220.0000
80.00	6.3010	220.0000
90.00	6.7010	220.0000
100.00	7.0000	220.0000
130.00	7.5010	220.0000
160.00	8.2980	220.0000
200.00	8.5020	220.0000
260.00	9.2000	220.0000
320.00	9.6990	220.0000
380.00	10.2010	220.0000
500.00	10.8990	220.0000

Again, it is not important to have the data lines aligned as in the example above. Data must be separated by at least one space.

Area ASCII File

```
1000.00 1000.00 50
1170.14 1000.00 51
1170.14 891.22 52
1147.34 891.22 53
1147.34 841.22 54
1159.34 841.22 55
1159.34 771.22 56
1077.84 771.22 57
1077.84 914.62 58
1000.00 914.62 59
1000.00 1000.00 50
/*
```

This is a simple file which contains two columns: Z and Y coordinates. The last line's coordinates must coincide with the first line's coordinates. The file must terminate with /*. You may have two or more areas within the same ASCII file. Each area is separated from the next with a line containing the combination /*.

Text ASCII File (for mapping application)

```
"SOLVENT BUILDING" 1020 970
10 0 17 49 0 "Palton" 0 0 0 1 0 0
```

The format of this file is explained in Chapter 15, section 15.7.6.

An ASCII text file with more than one line of text is reproduced below. It stores the information on labeling lithologic cross sections on a map. There are 3 cross sections identified as North-South, NW-SE, and West-East.

```
"NW" 1110 1043
10 0 17 56 0 "Palton" 0 0 0 1 0 0
"NORTH" 1210 1040
10 0 17 49 0 "Palton" 0 0 0 1 0 0
"WEST" 965 915
10 0 17 56 0 "Palton" 0 0 0 1 0 0
"EAST" 1247 892
10 0 17 56 0 "Palton" 0 0 0 1 0 0
"SOUTH" 1200 750
10 0 17 56 0 "Palton" 0 0 0 1 0 0
"SE" 1235 760
10 0 17 56 0 "Palton" 0 0 0 1 0 0
```

Grid File. This is a portion of a grid file. The important thing to remember is the number of rows (NR) and columns (NC) in a grid model. The file must contain NRxNC values. They may start from the lowermost row or from the uppermost row, since, when input into GWW the program will ask first whether the ordering is from Ymin to Ymax, or the other way around. The number of decimal points is not important, neither is the alignment of data columns, as long as the data are separated by at least one space.

75.9089	75.9592	71.7994	71.9027	72.0099
71.6541	71.2471	71.3617	71.1524	71.2424
71.3354	71.4302	71.5275	70.4314	70.5159
70.7258	70.9576	71.2168	71.5073	71.3087
71.6741	70.9735	73.8004	75.6722	75.8195
75.9486	76.0329	76.0291	75.5818	75.0766
74.4473	73.7384	73.0179	72.3480	71.7709
71.2997	70.9180	70.6734	70.4999	70.3836
70.3149	70.2850	71.5821	71.7099	67.9782
67.9463	67.9067	67.5712	67.8304	67.7950
75.8668	75.9182	71.8866	71.4863	71.6143
71.7295	71.3211	71.2226	71.3183	71.4164
71.5158	71.6163	70.4442	70.6280	70.7216
70.9397	71.1814	71.4509	72.2406	72.4705
71.8986	73.9599	74.3612	74.7862	75.9888
76.2072	76.4075	76.5527	76.3016	75.8729

APPENDIX E

Several ASCII files with extension .dlt (stands for Define Lithology) have special meaning in the GWW package. These files are:

- SCREEN.DLT,
- LITH.DLT, and
- ANNULUS.DLT.

The files with the default extension .dlt contain preprogrammed symbols for various lithological units, for well screen, and for materials filling the annular space between the drilled hole and casing. You can use these symbols without modification, or you can make your own.

Each symbol is defined with symbol name, which is the first word in a .dlt file (e.g. CLAY, SILT; up to 10 characters, sensitive to the case of letters, that is upper case and lower case are not the same), and description which will show on the printed log. This is one or more words after the symbol name.

The file SCREEN.DLT is the shortest and is fully reproduced below.

```
SCREEN Screen
22 255 255 127 0 0 0
2 0.00 1.00
1 0.00 2.00
2 1.00 0.00
1 1.00 1.00
*
EMPTY Empty
10 10 255 255 191 0 0 0
2 0.00 0.00
*
```

In this file there are only two symbols; one for screen defined as SCREEN, the other for blank casing defined as EMPTY. You must not change this file's coded names. You may change the way in which a symbol is designed.

The file ANNULUS.DLT is also fully reproduced below.

CEMENT CONDUCTOR\PIPE

4.6 3.9 255 191 191 127 0 127

2030

150

2005

1505

2011

149 1.1

2018

149 1.8

2024

149 2.4

2031

153.1

2037

153.7

*

CLAYH CLAY hard

3 1 127 255 63 191 63 63

2005

00.81

115 0.5

02.30

13 0.5

*

GWS GRAVEL pack\gravel & sand

4 5 63 255 255 63 0 127

204

015

124

013

104

221

032

141

030

121

212

11.12

233

13.13

2051

10.61

222.5

12.125
234
13.14
20.505
10.605
*
SAND SAND
22 191 255 255 00 127
200
1030
10303
100
211
1131
11313
111
21305
11405
11306
20311
10411
10313
20715
10915
10917
10717
20802
10704
10804
10803
2171
11612
11712
1181
21615
11516
11717
11715
20406
10408
10607
20116
10117
10217
21601

1 1.6 0.3

1 1.7 0.3

*

This file contains several symbols that may be used to fill the annular space between the walls of the drilled hole and casing. You may add more symbols, rename codes and type another description.

Only a portion of the file LITH.DLT is reproduced below. This file contains codes and description for lithological units that may appear on a well log.

CLAY CLAY

3 1.5 2.55 2.55 1.91 2.55 0 0

2 0.00 0.75

0 0.75 1.50

1 1.50 0.75

0 2.25 0.00

1 3.00 0.75

*

SILT SILT

2 2 2.55 2.55 1.91 2.55 0 0

2 0 0

1 1 1

*

CWIOS CLAY with interbeds of sand

3 4 2.55 2.55 1.91 1.27 0 63

2 0 2.9

0 0.8 3.6

1 1.5 2.9

0 2.3 2.1

1 3 2.9

2 0 1.4

0 0.8 2.1

1 1.5 1.4

0 2.3 0.6

1 3 1.4

2 0 2.0

1 0.4 0.2

2 1 2.0

1 1.4 0.2

2 2 2.0

1 2.4 0.2

*

DOLO DOLOMITE

3 4 191 255 127 0 0 63

201

131

203

133

2033

102

232

12.71

2123

1154

2150

1181

*

GRAVEL GRAVEL

45 127 255 255 0 0 127

204

015

124

013

104

221

032

141

030

121

212

11.12

233

13.13

2051

10.61

222.5

12.125

234

13.14

20505

10.605

*

GWS GRAVEL with sand

5 191 255 255 0 0 127

204

015

124

...

*

LIME LIMESTONE

3 4 255 255 191 0 0 0

2 0 1

1 3 1

2 0 3

1 3 3

2 0 1

1 0 3

2 1 5 0

1 1 5 1

2 1 5 3

1 1 5 4

*

ROCK1 Rock1

2 2 255 255 255 0 0 0

2 0 1

1 2 1

*

ROCK2 Rock2

1 1 255 255 255 0 0 0

2 0 0 5

1 1 0 5

*

ROCK3 Rock3

0 5 0 5 255 255 255 0 0 0

2 0 0 3

1 0 5 0 3

*

ROCK4 Rock4

2 2 255 255 255 0 0 0

2 0 5 1

1 1 5 1

2 1 1 5

1 1 0 5

*

ROCK5 Rock5

1 1 255 255 255 0 0 0

2 0 3 0 5

1 0 8 0 5

2 0 5 0 3

1 0 5 0 8

*

ROCK6 Rock6

3 3 255 255 255 0 0 0
2 1 1.5
1 2 1.5
2 1.5 1
1 1.5 2
*

ROCK7 Rock7
2 2 255 255 255 0 0 0
2 0.5 1.5
1 1 1
2 1 1
1 1.5 1.5
*

ROCK8 Rock8
3 3 255 255 255 0 0 0
2 0 0
1 3 3
*

ROCK9 Rock9
2 2 255 255 255 0 0 0
2 0 0
1 2 2
*

SAND SAND
2 2 191 255 255 0 0 127
2 0 0
1 0.3 0
1 0.3 0.3
1 0 0
2 1 1
1 1.3 1
1 1.3 1.3
1 1 1
*

The meaning and creation of symbols will be explained using simple examples from the file LITH.DLT. Take for example the symbol for SILT. The block for silt is copied here below.

SILT SILT
2 2 255 255 191 255 0 0
2 0 0

111

*

The first line contains the code for silt "SILT", and the default description that will be typed in well log if you do not override the default. (You can also modify this default by adding a word or more to Silt to better identify the unit. This will then become the default for SILT. Or, you may translate this word into another language, say, Spanish, in which case the word would be probably LIMO or POLVO.) The code may have up to 10 characters. The description may be any combination of up to 100 characters. You may break the description with a backslash character, \. This is the instruction to the program to start with the next line after the backslash character is encountered.

The second line contains two numbers which define the size of a block, followed by six numbers that define the color of the background field and of the symbol itself. The philosophy of creating symbols is related to the size of blocks. One block is repeated in both horizontal and vertical direction in the log. One may think of small building blocks, such as bricks of exactly the same size and shape, which are laid on top and side one from the other to fill the whole space. The numbers 2 2 imply a square, so that any symbol defined in such a square shall be symmetrically repeated horizontally and vertically. We will demonstrate this concept later.

The six numbers defining the color are, in the following order, Red, Green, Blue (RGB) for the background, and Red, Green, Blue (RGB) for the symbol. Remember that the number 0 is black, and the number 255 white. The combination 255,0,0 is red; the combination 0,255,0 is green; the combination 0,0,255 is blue.

The combination 255,255,191 is interpreted as light yellow background, while the combination 255,0,0 is red symbol for silt.

The block for silt, as well as any other symbol, terminates with *. Between the second line and the asterisk sign,

there may be one or many lines. The first number in each such line can be 2, 1 or 0. The number 2 defines the starting point, number 1 means "connect this point with the previous", number 0 means "make an arc through this point without actually passing through it". In the third line of the SILT block, the remaining two numbers (0,0) define X and Y coordinates of the starting point within the block defined by 2 by 2. The number 1 on the next line is interpreted as "connect the starting point with this point", and the coordinates of this second point are 1.0 and 1.0. When this is interpreted, the diagonal line appears in the lower one half of the square, connecting the point with coordinates (0,0) with the point with coordinates (1,1). Since the small block which defined the symbol is repeatedly used, the final appearance of this symbol is as is usually used for SILT. If you want to create a symbol for horizontal lines widely spaced, such as the default symbol ROCK1, the design would be as follows:

```
ROCK1 Rock1 (you may type something else)
2 2 255 255 255 0 0 0 (white background, black line)
2 0 1
1 2 1
*
```

This is equivalent to saying "draw a straight line from starting point with X,Y coordinates (0,1) to ending coordinates (2,1)", which is along the middle of the block of size 2,2. If you want denser horizontal lines, the block to define should be smaller, and so will be the spacing between repeating blocks. For example,

```
ROCK2 Rock2
1 1 255 255 255 0 0 0
2 0 0.5
1 1 0.5
*
```

Very narrowly spaced horizontal lines can be obtained by assigning even smaller size to the block, say 0.5 by 0.5. Thus the design for ROCK3 may be as follows:

```
ROCK3 Rock3
0.5 0.5 255 255 255 0 0 0
```

2 0 0.25
 1 0.5 0.25
 *

This is interpreted as "connect the point with coordinates 0,0.25 with point coordinates 0.5,0.25".

In addition to connecting two points with straight lines, you may create an arc between two points. This is done by inserting a line with the first number 0 between two lines starting with the number 2 or 1. Suppose you want to create a sinusoidal line with amplitude 1.5 and period 3.0. The block to define shall be 3 by 1.5. The fixed points should be at coordinates (0,0.75), (1.5,0.75), (3,0.75). These will be the three lines with starting number either 2 (for the first point) or 1 (for the remaining two points). The top of arc shall be at the point (0.75,1.5), and the bottom of arc at the point (2.25,0). Thus the block to define a sinusoidal line, which may be used to describe clay, may look as follows:

CLAY Clay
 3 1.5 255 255 255 0 0 0
 2 0 0.75
 0 0.75 1.5
 1 1.5 0.75
 0 2.25 0
 1 3 0.75
 *

By reducing the height of the block from 1.5 to 1.0 the waves will become more "ironed" and lines closer. For example, one may design the following block for schist or shale:

SCHIST Paleozoic Schist
 3 1.0 255 255 255 0 0 0
 2 0 0.5
 0 0.75 1
 1 1.5 0.5
 0 2.25 0
 1 1.5 0.5
 *

You may connect several points to create a circle, or any rounded, or semirounded object. Let us create a design for semirounded fine gravel. Define this block as 3 by 2.

SRGRAV Semi-rounded gravel

```
3 2
2 0.7 0.4
1 0.7 1.5
0 1.4 1.9
1 1.9 1.4
0 2 1
1 1.6 0.5
0 1.15 0.2
1 0.7 0.4
*
```

As an exercise, double the size of this block and create gravel grains in checkered position, i.e. second line shifted to middle between two grains in lines above and below.

Now we will create a symbol for "Clay alternating with fine sand". Define block as 3 by 2.5, and use the upper 1.5 units for clay (actually, duplicate the design of CLAY), and lower one unit for sand. Start with "Clay line" in the upper 1.5 units. The starting point will be at coordinates (0.00,1.75), and fixed points at (1.50,1.75) and (3.00,1.75). The arc should pass through the points (0.75,2.50) and (2.25,1.00). Thus, the upper part of the block would be as follows:

```
3 2.5 255 255 255 255 0 0 (red line on white background)
2 0 1.75
0 0.75 2.5
1 1.5 1.75
0 2.25 1
1 3 1.75
```

The "sand" portion of the design will be in the lower 1.0 unit, i.e. within the block defined by coordinates 0,0; 0,1; 3,1; 3,0. The "sand" grains are created by connecting points through small distance. For example,

```
2 0 0
```

10.10
 20.50
 10.60
 210
 11.10
 etc.

The final design for "Alternating bands of clay with fine sand" could be as shown here below. (In your file, this should be typed line after previous line, continuously, not in three columns.)

ABOCWFS Alternating\bands of clay\with fine sand

3 2.5 255 255 255 0 0 0 (Line #1, followed by:)

2	0.00	1.75	2	2.50	0.00	2	0.00	0.80
0	0.75	2.50	1	2.60	0.00	1	0.10	0.80
1	1.50	1.75	2	0.20	0.40	2	0.50	0.80
0	2.25	1.00	1	0.30	0.40	1	0.60	0.80
1	3.00	1.75	2	0.70	0.40	2	1.00	0.80
2	0.00	0.00	1	0.80	0.40	1	1.10	0.80
1	0.10	0.00	2	1.20	0.40	2	1.50	0.80
2	0.50	0.00	1	1.30	0.40	1	1.60	0.80
1	0.60	0.00	2	1.70	0.40	2	2.00	0.80
2	1.00	0.00	1	1.80	0.40	1	2.10	0.80
1	1.10	0.00	2	2.20	0.40	2	2.50	0.80
2	1.50	0.00	1	2.30	0.40	1	2.60	0.80
1	1.60	0.00	2	2.70	0.40	*		
2	2.00	0.00	1	2.80	0.40			
1	2.10	0.00						

Of course, you may create symbols in an easier way, using the On-Screen editing option in the Well Log and Lithology application. But for that you will need some practice.

The important thing to remember is that the program will stop you from attempting to type a non-existing symbol. In the Well Log and Lithology application you first tell the program which file with lithological symbols you are going to use, then you type depths and codes.



**FACULTAD DE INGENIERIA U.N.A.M.
DIVISION DE EDUCACION CONTINUA**

**VIII CURSO INTERNACIONAL DE CONTAMINACION DE
ACUIFEROS**

**MODULO III: MODELOS MATEMATICOS EN
GEOHIDROLOGIA Y CONTAMINACION DE ACUIFEROS**

TEMA : SISMOLOGIA

**EXPOSITOR: ING. ALFONSO ALVAREZ MANILLA
1996**

ANALYSIS FOR THE MULTIPLE-DIPPING-LAYER STRUCTURE: A
COMPUTER PROGRAM

This chapter contains a computer program by which to solve the dipping layer problem of refraction seismology for any number of layers. Chapter 12 describes an equivalent procedure for use with slide rule or desk calculator. Chapter 13 provides the theory underlying both of these methods, and describes how to compute theoretical refraction travel-time graphs for an arbitrary number of dipping layers. For the three-dipping-layer problem, a simple approximate method is given in Chapter 9.

The interpretation of refraction seismic data always starts from some simplified model of the subsurface structure. This model may be very simple indeed, such as a horizontal layer overlying a higher-velocity substratum. We call this a two-layer model. More complicated models may include multiple layers, or dipping layers, or faulted offsets, or velocity gradients. In all cases, however, the interpretation procedure goes as follows:

- (1) Assume a model, making it as close to the expected subsurface conditions as possible.
- (2) Compute the expected refraction travel-time graph.
- (3) Show the relationship between parameters of the structure (depths, dips, velocities, etc.) and parameters of the travel-time graph (slopes, intersection distances, intercept times, etc.)
- (4) Check that the field data yield an observed travel-time graph which looks reasonably like the expected travel-time graph for this structural model.
- (5) Read the parameters of the observed travel-time graph and compute the parameters of the structure from the relationships in (3).

A simple example of this is the horizontal two-layer structure shown in Figure 1. The velocities V_1 and V_2 for the subsurface structure are shown to equal the (reciprocal) slopes of the two line segments on the travel-time graph. The depth to the boundary is computed from the intersection distance X_c for the two line segments as

$$D = \frac{X_c}{2} \sqrt{\frac{V_2 - V_1}{V_2 + V_1}}$$

We will now give a method of solution for a very general model which is capable of handling a large fraction of the interpretation problems of engineering seismology. This model consists of an arbitrary number of constant-velocity layers. Each of the boundaries between layers may dip at an arbitrary angle.

This general model includes many special cases of practical importance. A few of them are shown in Figure 1, such as the horizontal two-layer problem, etc. (Note that any horizontal layer problem is a special case of a dipping layer problem, where the dips are zero.)

Figure 1 also shows the nomenclature which describes the subsurface model. Velocities are given as V_1, V_2, V_3, V_4 , etc. Layer thicknesses are given as H , and depths to the bottom of layers as D . The letters A and B show the two end points of the seismic profile which is to be interpreted. For the dipping layer structures, layer thicknesses are given as HA at position A and HB at position B , and similarly for DA and DB .

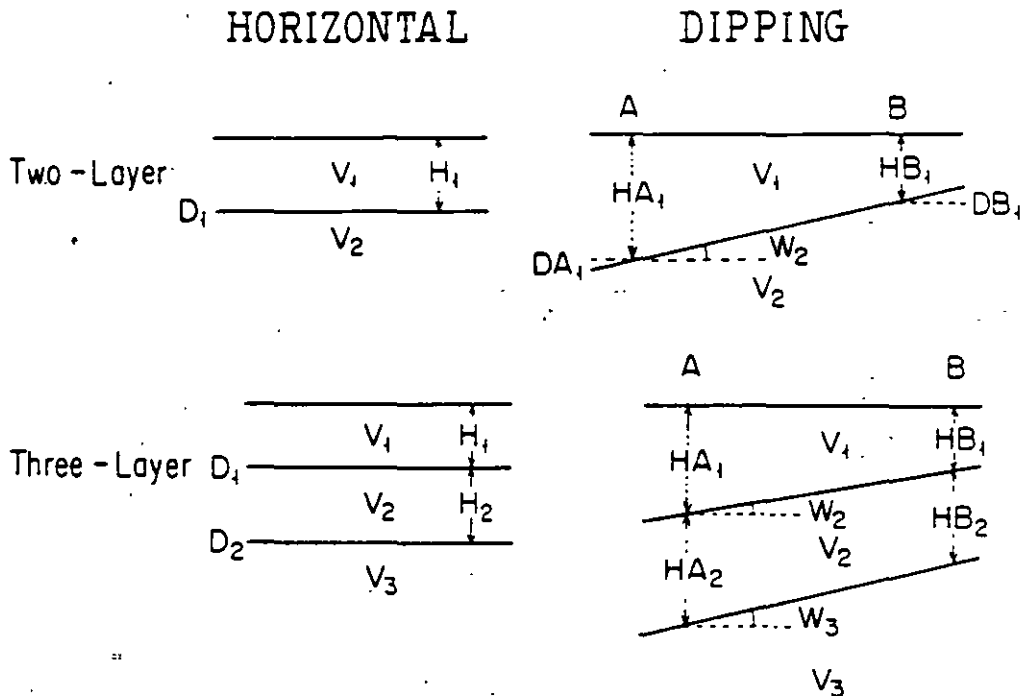

Figure 1: Subsurface models for seismic interpretation. Only two-layer and three-layer models are shown, but the general case may include any number of layers. The symbols for multiple-layer models will follow the same pattern shown here.

Dip angles for the boundaries are given as W_2, W_3, W_4 , etc. The sign convention is as follows: A positive value for W means that the boundary is dipping upward from A toward B , as shown in the figure; a negative value for W therefore means that the actual dip is downward from A toward B .

This proposed model is very general, but it does have some limitations. The actual subsurface conditions must satisfy these limitations, at least to a rough approximation, or else the resulting interpretations will contain serious errors. These limitations include:

- (1) The velocity within each layer is approximately constant.
- (2) Each successive layer has a higher velocity than the one above it (that is, there are no velocity inversions).
- (3) The boundaries between layers are plane, although not necessarily horizontal. If a boundary has an irregular surface, then the computed solution will give a plane surface which smooths out the irregularities.

We now consider what the observed travel-time graphs from the field data should look like. First of all, the seismic profile must be reversed, that is, two sets of observations must be taken in opposite directions along the seismic profile line AB. For example, a geophone would be placed at A, and readings would be taken for impact stations between A and B. The geophone would then be placed at B, and readings would be taken for impact stations from B back to A. Since the line AB is common to both profiles, it is customary although not essential to put both sets of data on the same graph sheet as shown in Figure 2.

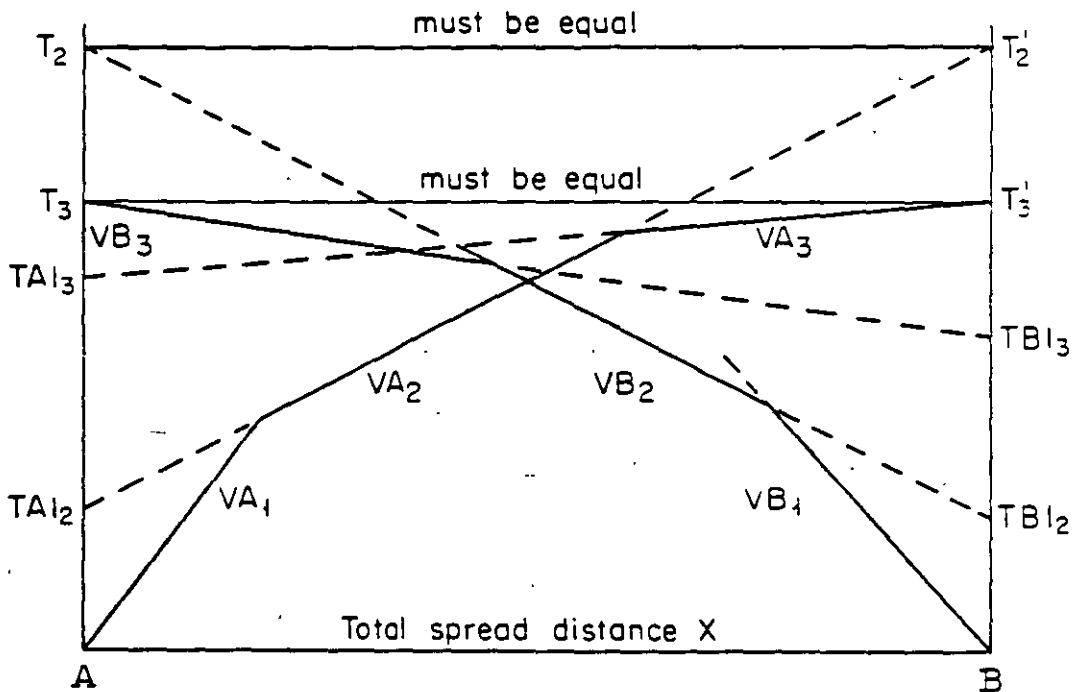

Figure 2: Expected travel-time graph for a structure consisting of three dipping layers. A similar pattern of symbols would be used for structures with more or less layers.

Figure 2 illustrates the nomenclature which is used to describe the observed travel-time graphs. The example in Figure 2 is for a dipping three-layer structure. The first-arrival data measured from position A are defined by three straight-line segments. The (reciprocal) slopes of these lines are called apparent velocities and are designated by symbols $VA_1, VA_2,$ and VA_3 . The second and third line segments are extended back to the left and intersect the axis at intercept times TAI_2 and TAI_3 . Similarly, the apparent velocities measured from position B are labelled $VB_1, VB_2,$ and VB_3 , and the time intercepts are TBI_2 and TBI_3 .

In general, the number of line segments will be equal to the number of layers. For the two-layer case, for example, there would be only two apparent velocities from A, VA_1 and VA_2 , with a single time intercept, TAI_2 , and similarly from B. For the four-layer case, there would be four apparent velocities and three intercept times for A, and similarly for B. By observing the number of line segments on the field travel-time graph, we know that the number of layers in the subsurface structure must be the same number. If we saw five line segments from each end, we would know that we had a five-layer structure.

The observed travel-time graph must fit this pattern of straight-line segments, or else the structural model we are considering will not be satisfactory for the area under investigation. *Furthermore, the observed travel-time graph must be forced to satisfy the following two conditions before the interpretation can proceed.* If these conditions cannot be forced onto the travel-time graph, then the proposed structural model will not be satisfactory.

Condition 1: $VA_1 = VB_1$, that is, the apparent velocities of the first two line segments at velocity of the first line segment from position A must be the same as the apparent velocity of the first line segment from position B.

Condition 2: $T_2 = T'_2, T_3 = T'_3, T_4 = T'_4,$ etc. for every pair of line segments which appears on the graph.

The second condition is called the requirement of reciprocity, and merely states that the total travel time from A to B must be the same as the total travel time from B to A. The times $T_2, T'_2, T_3,$ etc. are obtained simply by extending the straight-line segments until they intersect the vertical axis at A or at B.

In practice, the requirement of reciprocity places an important limitation on how the straight lines may be fitted to the data points on the travel-time graph. One usually draws the best and most obvious straight lines first. The condition of reciprocity is then used to adjust the remaining straight lines through the data points of lower quality.

As mentioned earlier, a reversed profile is required for a complete interpretation. If data are available only in one direction, say from position A, and if the interpreter has reason to believe that the layering is essentially horizontal, then he may assume that the profile from position B would be the same as from position A. In other words, he may take $VB_1 = VA_1, VB_2 = VA_2, TBI_2 = TAI_2,$

etc., and proceed with the computation. This procedure is not recommended because it includes the additional assumption of horizontal layering which may not be satisfied.

To summarize the preceding, we suppose that we have an observed travel-time graph for a reversed seismic profile. We have drawn straight line segments onto the graph so as to best fit the observation points. Furthermore, we have drawn these straight lines in such a way that they satisfy the condition of reciprocity. The number of line segments (call it N) from position A is equal to the number of line segments from position B. The number of layers in the subsurface structure is also equal to N .

From the travel-time graph, we read the following quantities:

Apparent velocities from position A: $VA_1, VA_2, VA_3 \dots VA_N$

Apparent velocities from position B: $VB_1 (=VA_1), VB_2, VB_3 \dots VB_N$

Intercept times at position A: $TAI_2, TAI_3 \dots TAI_N$

Intercept times at position B: $TBI_2, TBI_3 \dots TBI_N$

The following computer program will take these observed data as inputs, and provide depths, dips, and velocities of the structure as outputs.

The input data include a quantity M , which should be set equal to 0 if the intercept times are read in seconds and should be set equal to 1 if they are read in milliseconds. The symbol X designates the seismic profile length from A to B; this quantity may be in feet, meters, or kilometers provided the apparent velocities use the same units.

```

        DIMENSION W(10),V(10),VA(10),VB(10),ALPH(10),BETA(10),Q(10),
        1  A(10),B(10),TAI(10),TBI(10),MA(10),MB(10),OA(10),OB(10),P(10),
        2  TITLE(8)
C SET M = 1 IF INTERCEPT TIMES ARE IN MILLISECONDS, M = 0 IF IN SECONDS.
C N = NUMBER OF LAYERS, INCLUDING HALF-SPACE. ALSO, N = NUMBER OF TRAVEL-
C   TIME SEGMENTS.
C X = PROFILE LENGTH FROM A TO B, IN METERS, KILOMETERS, OR FEET.
C VA(I) = APPARENT VELOCITIES FROM A END, I = 1..N.
C VB(I) = APPARENT VELOCITIES FROM B END, I = 1..N.
C TAI(I) = INTERCEPT TIMES FROM A END, I = 2..N.
C TBI(I) = INTERCEPT TIMES FROM B END, I = 2..N.
C INPUT DATA ARE CHECKED TO ASSURE THAT THEY SATISFY RECIPROCALITY AT LEAST
C   WITHIN 10 PERCENT.
C IF B-END INTERCEPT TIMES, TBI, ARE NOT SUPPLIED AS INPUT, THE PROGRAM WILL
C   COMPUTE THEM FROM RECIPROCALITY. INSERT A BLANK CARD WHERE THEY ARE
C   CALLED FOR AS INPUT DATA.
400 PRINT 401
401 FORMAT (1M1)
C N=NUMBER OF LAYERS OR TRAVEL TIME SEGMENTS, X=END-TO-END SPREAD LENGTH.
  READ 405,M,N,X,(TITLE(I),I=1..6)
405 FORMAT (2I2,F8.0,6A8)
  IF (N) 640,640,407
407 READ 410,(VA(I),I=1..N)
410 FORMAT (9F8.0)
  READ 410,(VB(I),I=1..N)
  READ 410,(TAI(I),I=2..N)
  READ 410,(TBI(I),I=2..N)
  TAI(1) = 0.
  TBI(1) = 0.
  PRINT 411,(TITLE(I),I=1..6),X
411 FORMAT (2X,6A8,15HSPREAD LENGTH = ,F8.0,/)
  PRINT 412
412 FORMAT ( 2X,10HINPUT DATA //10X,5H1LAYER,10X,8HAPPARENT , 10X,
1 8HAPPARENT,10X,9HINTERCEPT, 9X,9HINTERCEPT / 23X,13HVELOCITIES, A
2 5X,13HVELOCITIES, B,7X,8HTIMES, A,10X,8HTIMES, B //)
  IF (M) 414,417,414
414 PRINT 415, (I,VA(I),VB(I),TAI(I),TBI(I),I=1..N)
415 FORMAT (I12,F22.2,F18.2,F17.1,F18.1)
  DO 416 I = 2..N
  TAI(I) = TAI(I)/1000.
416 TBI(I) = TBI(I)/1000.
  GO TO 419
417 PRINT 418, (I,VA(I),VB(I),TAI(I),TBI(I),I=1..N)
418 FORMAT (I12,F22.2,F18.2,F17.4,F18.4)
419 CONTINUE
421 DO 430 I = 2..N
  TBB = TAI(I) + X*(1./VA(I) - 1./VB(I))
  IF (TBI(I)) 422,422,423
422 TBI(I) = TBB
  GO TO 430
423 TAEND = TAI(I) + X/VA(I)
  TBEND = TBI(I) + X/VB(I)
  ERROR = ABS (TAEND/TBEND - 1.)
  IF (ERROR = 0,10) 430,424,424
424 PRINT 425,I
425 FORMAT (5X, 7HAPPARENT VELOCITY AND TIME INTERCEPT DATA ARE IN
1CONSISTENT AT LAYER NUMBER ,I2,/,7X,56HEND-TO-END TRAVEL TIMES O
2DIFFER BY MORE THAN 10 PERCENT. //)
430 CONTINUE
  V(1) = (VA(1) + VB(1))*0.5
  DO 570 M = 2..N
  K = 1
  ALPH(1) = ASIN (V(1)/VB(M))
  BETA(1) = ASIN (V(1)/VA(M))
  IF (M=2) 500,500,510

```

```

500 A(1) = (ALPH(1) + BETA(1))*.5
    W(2) = (ALPH(1) - BETA(1))*.5
    V(2) = V(1)/SIN (A(1))
    GO TO 550
510 A(1) = ALPH(1) - W(2)
    B(1) = BETA(1) + W(2)
520 K = K+1
    VV = V(K)/V(K-1)
    P(K) = ASIN (VV*SIN (A(K-1)))
    Q(K) = ASIN (VV*SIN (B(K-1)))
    IF (K+1=N) 530,540,540
530 A(K) = P(K) + W(K+1) + W(K)
    B(K) = Q(K) + W(K+1) - W(K)
    ALPH(K) = A(K) + W(K+1)
    BETA(K) = B(K) - W(K+1)
    GO TO 520
540 A(K) = (P(K) + Q(K))*.5
    B(K) = A(K)
    W(K+1) = W(K) + (P(K) - W(K))*.5
    ALPH(K) = A(K) + W(K+1)
    BETA(K) = B(K) - W(K+1)
    V(K+1) = V(K)/SIN (A(K))
550 KK = K-1
    MHA = 0.
    MHB = 0.
    IF (KK) 561,561,551
551 DO 561 I = 1, KK
    MH = COS (ALPH(I)) + COS (BETA(I))
    MH = MH/V(I)
    MHA = MHA + MH*MHA(I)
    MHB = MHB + MH*MHB(I)
560 MHA = MHA + MH*MHA(I)
    MHB = MHB + MH*MHB(I)
561 CONTINUE
    R = V(K)/(COS (ALPH(K)) + COS (BETA(K)))
    HA(K) = R*(TA(K+1) - MHA)
    HB(K) = R*(TB(K+1) - MHB)
    DA(1) = HA(1)
    DB(1) = HB(1)
    IF (K-1) 570,570,569
569 DA(K) = DA(K-1) + HA(K)
    DB(K) = DB(K-1) + HB(K)
570 CONTINUE
    DO 580 J = 2, N
580 W(J) = W(J)*57.2958 + 0.001
    PRINT 620
620 FORMAT (/// 2X,18MCOMPUTED STRUCTURE // 9X,5MLAYER, 6X,9HVELOCITY *
1 , 6X,11MTHICKNESS A, 4X,11MTHICKNESS B, 8X,3HDIP,10X,7HDEPTH A,
2 , 8X,7HDEPTH B //)
    I = 1
    PRINT 625, I, V(I), HA(I), HB(I), DA(I), DB(I)
625 FORMAT (I12,3F15.2,15X,2F15.2)
    IF (N-2) 632,632,627
627 NN = N - 1
    PRINT 630,(I, V(I), HA(I), HB(I), W(I), DA(I), DB(I), I=2, NN)
630 FORMAT (I12,6F15.2)
632 PRINT 635, V(N), W(N)
635 FORMAT (I12, F15.2, 30X, F15.2)
    PRINT 638
638 FORMAT (//////,5X,*OUTPUT DATA ARE PRINTED TO TWO DECIMAL PLACES,*
1/,5X,*BUT NO IMPLICATION IS INTENDED THAT THE SEISMIC RESULTS HAVE
1 THIS DEGREE OF RELIABILITY,*)
    GO TO 400
640 CONTINUE
    END

```

SPREAD LENGTH = 1000.

INPUT DATA

LAYER	APPARENT VELOCITIES, A	APPARENT VELOCITIES, B	INTERCEPT TIMES, A	INTERCEPT TIMES, B
1	4000.00	4000.00	0	0
2	7930.00	9000.00	.0150	.0300
3	14760.00	16200.00	.0620	.0680

COMPUTED STRUCTURE

LAYER	VELOCITY	THICKNESS A	THICKNESS B	DIP	DEPTH A	DEPTH B
1	4000.00	34.11	48.21		34.11	48.21
2	8426.29	229.04	176.37	-1.95	263.15	244.58
3	15427.63			1.06		



**FACULTAD DE INGENIERIA U.N.A.M.
DIVISION DE EDUCACION CONTINUA**

CURSOS ABIERTOS

**“ IX CURSO INTERNACIONAL DE CONTAMINACIÓN DE
ACUÍFEROS**

MODULO III

**MODELOS MATEMÁTICOS EN GEOHIDROLOGÍA Y
CONTAMINACIÓN DE ACUÍFEROS**

TEMA

**MANUAL DEL USUARIO PARA EL PROGRAMA
DE SOLUCIÓN DIRECTA E INVERSA EN LOS
SONDEOS ELÉCTRICOS VERTICALES**

**EXPOSITOR: ING. ALFONSO ALVAREZ MANILLA ACEVES
1997**

1. INTRODUCCION:

Para la solución en la interpretación de las curvas de resistividad aparente en los sondeos eléctricos verticales (SEV) se ofrecen dos opciones: "directa" e "inversa".

La solución directa calcula la curva de resistividad aparente de un corte geoelectrico teórico, mientras que la solución inversa encuentra el corte geoelectrico de la curva de resistividad aparente obtenida en campo.

La solución directa es por medio de la teoría del filtrado lineal desarrollada por Ghosh, 1971. El programa inverse aplica el algoritmo de Marquart, 1963 para iniciar la obtención del modelo, lo modifica mediante iteraciones hasta que produce el mejor ajuste entre las curvas de campo y teóricas.

Los programas fueron modificados del artículo técnico de Philip A. Davis de la Minnesota Geological Survey por J. Cuauhtémoc Orendain M y Alfonso Alvarez Manilla A (1978).

El modelo se basa en un semiespacio dividido en un total de E_i capas horizontales, electricamente homogéneas e isotrópicas y de extensión infinita (figura 1), los parámetros incluyen a la resistividad (R_i) y espesores (H_{i-1}) de cada capa.

Los errores producidos pueden ser todavía disminuio con un proceso de retroalimentación; la interpretación con el programa inverse no manipula los problemas de equivalencia y supresión, los cuales deben ser observados por separado.

2. DESCRIPCION DE LOS PROGRAMAS.

El programa en el disco, presenta cuatro archivos principales:

RES_APRT.EXE que es el que contiene los ejecutables de los subprogramas CAPTURA, INVERSE Y RESIST.

FILTRO1 y FILTRO 2 contiene los filtros de Ghosh, los cuales pueden ser cambiados por los de Oneil, u otros.

NO87.BAT es un subprograma para simular la existencia de coprocesador matemático en caso de que no tenga el propio la máquina donde opere.

2.1 INICIO (RESIST)

Con el programa en la unidad de disco correspondiente, se teclea:

NO87 RETURN

y se visualiza el MENU PRINCIPAL con las opciones de:

1. CAPTURA
2. RESIST
3. INVERSE
4. FIN DE CAPTURA

PROGRAMA SELECCIONADO:_

primero es necesario capturar los datos, por lo que se teclea (1) RETURN

observando PROGRAMA CAPTURA con las opciones de:

1. RESIST
2. INVERSE
0. FIN DE PROGRAMA

PROGRAMA SELECCIONADO_

2.1a si se tiene la interpretación o presunción de un corte geoelectrónico determinado se oprime (1) RETURN

donde la pantalla muestra DATOS PARA EL PROGRAMA RESIST

NOMBRE DEL ARCHIVO DONDE SE ALMACENAN LOS DATOS:_

se teclea el nombre del archivo donde son guardados los datos, por ejemplo

DUAQ RETURN

aparece DATOS PARA EL PROGRAMA RESIST

TIPO DE ARREGLO: 1. SCHLUMBERGER
2. WENNER
3. BIPOLO-BIPOLO
0. FIN DE CAPTURA

NUMERO DEL ARREGLO DESEADO:

se teclea el número al arreglo eléctrico correspondiente:

(1) RETURN

ESPACIAMIENTO (AGREGAR PUNTO DECIMAL):

El espaciamento de AB/2 con el que se desea iniciar, asumiendo que fuera
1. RETURN

NUMERO DE CAPAS (ENTERO SIN PUNTO DECIMAL) 3 RETURN

NUMERO DE LECTURAS (ENTERO SIN PUNTO DECIMAL)
el número de lecturas corresponde a los espaciamentos generados
por la regla de correspondencia $A = A_i 10^{k/6}$ con $0 = k = M$
donde A_i es el espaciamento inicial, k un entero y M el total de
espaciamentos deseados 10 RETURN

aparece ahora == AGREGAR PUNTO DECIMAL A LOS SIGUIENTES VALORES ==

ESPEJOR (1) = _ 1. RETURN
ESPEJOR (2) = _ 10. RETURN

RESISTIVIDAD (1) = _ 1. RETURN
RESISTIVIDAD (2) = _ 10. RETURN
RESISTIVIDAD (3) = _ 0.1 RETURN

pregunta en la pantalla: ESTAN BIEN TUS DATOS? (S/N):_

Si fue cometido algún error en la captura de cualquier dato debe teclarse N,
exclusivamente este SEV no será codificado; caso contrario oprimir S RETURN

aparece: DATOS PARA EL PROGRAMA RESIST

TIPO DE ARREGLO: 1. SCHLUMBERGER
2. WENNER
3. BIPOLO-BIPOLO
0. FIN DE CAPTURA

NUMERO DEL ARREGLO DESEADO: _

como la captura de datos para el programa Resist ha concluido, se tecla 0 RETURN

pregunta si QUIERES OTROS DATOS (S/N)_

si se desea conocer las curvas de resistividad aparente de otros cortes, deberá
continuar con la secuencia inicial oprimiendo S RETURN, caso contrario N RETURN

aparece el MENU PRINCIPAL

OPCIONES DE PROGRAMAS

1. CAPTURA
2. RESIST
3. INVERSE
0. FIN DE PROGRAMA

PROGRAMA SELECCIONADO: _

como los datos capturados son del programa Resist, el número seleccionado debe ser el 2 RETURN

PROGRAMA RESIST

ARCHIVO DE DATOS: teclear DUAQ RETURN

ARCHIVO DE REPORTE: teclear un nombre diferente a DUAQ; RUAQ RETURN

aparece FAVOR DE ESPERAR UNOS MOMENTOS

al ser concluido el proceso, el MENU PRINCIPAL es mostrado en la pantalla

debiendo teclear 0 RETURN

Para observar los datos en la pantalla, teclear

TYPE RUAQ RETURN y detener con la tecla de PAUSA

para impresión de los datos teclear

TYPE RUAQ>LPT1:

2.2 INICIO (INVERSE)

El modelo de inversión contiene errores significativos al no considerar el principio de equivalencia y supresión de capas, lo cual hace a la "resolución única" imposible de existir.

La solución de la inversión no representa el modelo geológico real, lo que debe ser calibrado con los conocimientos de geología.

El método de inversión fue originalmente desarrollado por Merrick en 1977, se han hecho algunas modificaciones para incrementar la flexibilidad propia del programa.

Con el programa en la unidad de disco correspondiente, se tecléa:

NO87 RETURN

y se visualiza el MENU PRINCIPAL con las opciones de:

1. CAPTURA
2. RESIST
3. INVERSE
4. FIN DE CAPTURA

PROGRAMA SELECCIONADO:_

primero es necesario capturar los datos, por lo que se tecléa (1) RETURN

observando PROGRAMA CAPTURA con las opciones de:

1. RESIST
2. INVERSE
0. FIN DE PROGRAMA

PROGRAMA SELECCIONADO_

2.2a si se tiene la interpretación o presunción de un corte geoelectrico determinado se oprime (2) RETURN

donde la pantalla muestra DATOS PARA EL PROGRAMA INVERSE

NOMBRE DEL ARCHIVO DONDE SE ALMACENAN LOS DATOS:_

se tecléa el nombre del archivo donde son guardados los datos, por ejemplo

DAUAQ RETURN

aparece DATOS PARA EL PROGRAMA INVERSE

TIPO DE ARREGLO: 1. SCHLUMBERGER
2. WENNER
3. BIPOLO-BIPOLO
0. FIN DE CAPTURA

NUMERO DEL ARREGLO DESEADO:

se teclea el número al arreglo electrónico correspondiente:
(1) RETURN

ESPACIAMIENTO (NUMERO REAL, AGREGAR PUNTO DECIMAL):

El espaciamento de $AB/2$ con el que se desea iniciar, asumiendo que fuera
1. RETURN

NUMERO DE CAPAS (ENTERO SIN PUNTO DECIMAL) 3 RETURN

NUMERO DE LECTURAS (ENTERO SIN PUNTO DECIMAL)

el número de lecturas corresponde a los espaciamentos generados por la regla de correspondencia $A = A_i 10^{k/6}$ con $0 = k = M$ donde A_i es el espaciamento inicial, k un entero y M el total de espaciamentos deseados
10 RETURN

NUMERO DE PARAMETROS FIJOS (NUMERO ENTERO):

Si se tienen conocimiento de algún estrato, sus valores de espesor y resistividad quedan fijados y el programa no los manipula; información adicional es pedida subsecuentemente. Si no se tienen datos teclear 0 RETURN

PORCENTAJE DE ERROR (NUMERO REAL):

Es el error en la aproximación numérica deseado 1. RETURN

TIPO DE LECTURAS

1. SI LAS LECTURAS SON LOGARITMICAS
2. DE OTRO MODO

si las lecturas están tomadas en función a la regla de correspondencia $A = A_i 10^{k/6}$ con $0 = k = M$ son logarítmicas y se debe teclear 1 RETURN, caso contrario en la pantalla aparecerán preguntas acerca del espaciamento y resistividad aparente para cada estación de medida, en esta última opción debe ser tecleado el número 2RETURN

1 RETURN

aparece === TECLEAR SOLO NUMEROS CON PUNTO DECIMAL ===

RESISTIVIDAD APARENTE No 1:

los datos de resistividad aparente correspondientes a los diez espaciamentos y lecturas son introducidos, aparece al final

PARAMETROS DE LA CAPAS (TOTAL 5)

ESPESOR (1)=

ESPESOR (2)=

RESISTIVIDAD (1)=

RESISTIVIDAD (2)=

RESISTIVIDAD (3)=

pregunta en la pantalla: ESTAN BIEN TUS DATOS? (S/N):_

Si fue cometido algún error en la captura de cualquier dato debe teclearse N, exclusivamente este SEV no será codificado; caso contrario oprimir S RETURN

aparece: DATOS PARA EL PROGRAMA RESIST

TIPO DE ARREGLO: 1. SCHLUMBERGER
 2. WENNER
 3. BIPOLO-BIPOLO
 0. FIN DE CAPTURA

NUMERO DEL ARREGLO DESEADO:_

como la captura de datos para el programa Resist ha concluido, se tecla 0 RETURN

pregunta si QUIERES OTROS DATOS (S/N)_

si se desea conocer las curvas de resistividad aparente de otros cortes, deberá continuar con la secuencia inicial oprimiendo S RETURN, caso contrario N RETURN aparece el MENU PRINCIPAL

OPCIONES DE PROGRAMAS

1. CAPTURA
2. RESIST
3. INVERSE
0. FIN DE PROGRAMA

PROGRAMA SELECCIONADO:_

como los datos capturados son del programa Inverse, el número seleccionado debe ser el 3 RETURN

ARCHIVO DE DATOS: teclear DAUAQ RETURN

ARCHIVO DE REPORTE: teclear un nombre diferente a DAUAQ;
REUAQ RETURN

aparece FAVOR DE ESPERAR UNOS MOMENTOS

al ser concluido el proceso, el MENU PRINCIPAL es mostrado en la pantalla
debiendo teclear 0 RETURN

Para observar los datos en la pantalla, teclear

TYPE REUAQ RETURN y detener con la tecla de PAUSA

para impresión de los datos teclear

TYPE REUAQ>LPT1:

BIBLIOGRAFIA

Davis, P.A., 1979, Development and aplicaciones of resistivity sounding inversion for several field arrays: M.S. thesis, University of Minnesota, Minneapolis.

Ghosh, D., 1971, Application of linear filter theory to the direct interpretation of geoelectrical resistivity sounding measurements: Geophysical Prospecting, v.19.

Ghosh, D., 1971, Inverse filter coefficients for computation of apparent resistivity standar curves for horizontally layered earth. Geophysical Prospecting, v.19.

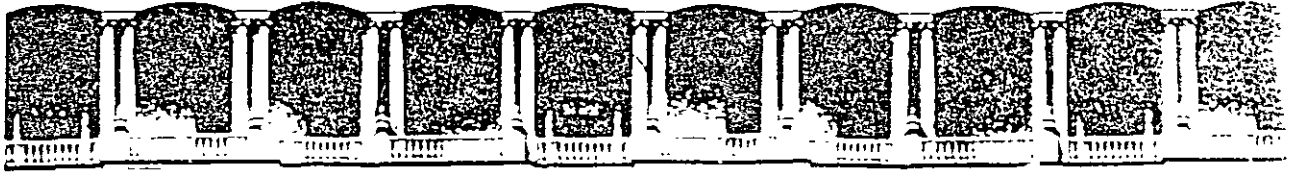

**FACULTAD DE INGENIERIA U.N.A.M.
DIVISION DE EDUCACION CONTINUA**

CURSOS ABIERTOS

**“IX CURSO INTERNACIONAL DE
CONTAMINACIÓN DE ACUÍFEROS”**

MODULO III

MODELOS EN GEOHIDROLOGÍA

TEMA

MODELOS DE FLUJO

EXPOSITOR : M en HIDROL. PEDRO R. SOTO NAVARRO

***CURSO INTERNACIONAL DE
CONTAMINACION DE ACUIFEROS***

MODELOS DE FLUJO

Expositor: Pedro R. Soto Navarro

México, D. F., octubre 6 de 1997

Ley de Darcy

$$Q = -K \frac{dh}{dl} A$$

$Q \rightarrow$ caudal $\frac{L^3}{T}$

$K \rightarrow$ conductividad hidráulica

$dh/dl \rightarrow$ gradiente hidráulico $\frac{L}{T}$

$A \rightarrow$ sección transversal L^2

Caudal específico:

$$v = \frac{Q}{A} \rightarrow L/T$$

Cantidad de masa que pasa a través de una sección dada:

densidad del agua o fluido \rightarrow $\rho v \rightarrow ML^{-3} \cdot LT^{-1} = ML^{-2}T^{-1}$

Ecuación de continuidad

Flujo de masa que ingresa

— Flujo de masa que sale

= Cambio de almacenamiento con el tiempo

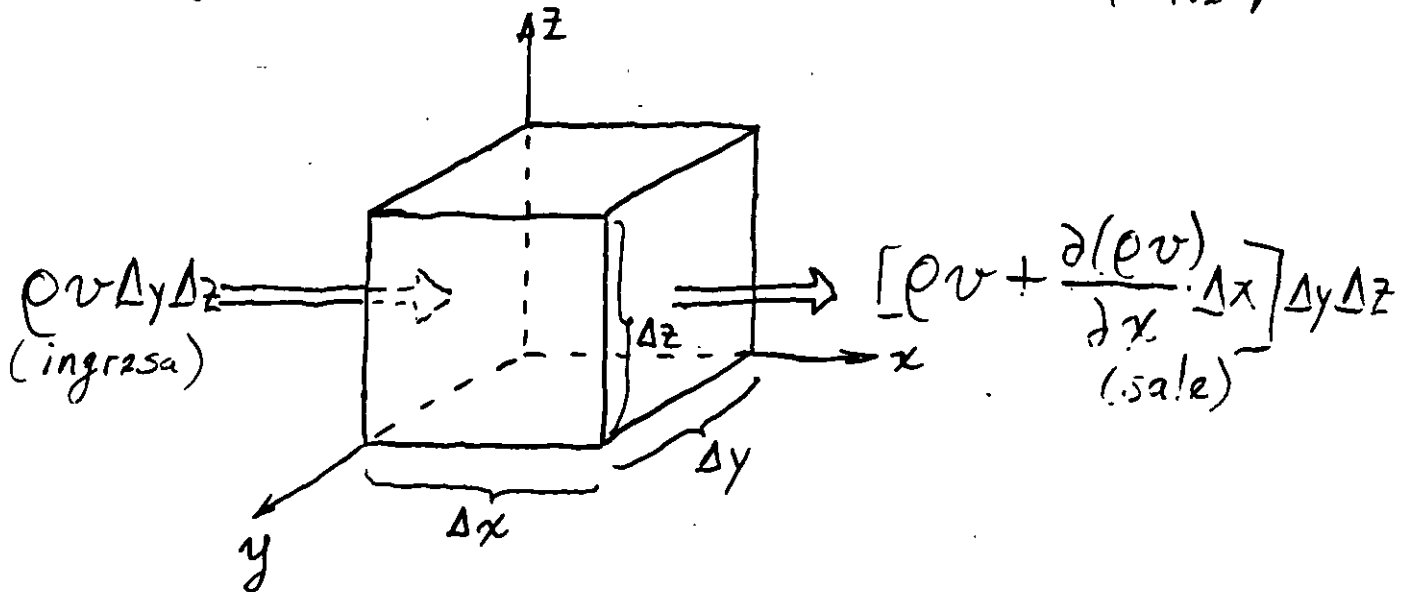

Flujo de masa entrante (dirección en x):
 $\rho v_x \Delta y \Delta z$

Flujo de masa saliente (dirección en x):
 $\left[\rho v_x + \frac{\partial(\rho v_x)}{\partial x} \Delta x \right] \Delta y \Delta z$

Flujo neto en la dirección x :
 $-\frac{\partial(\rho v_x)}{\partial x} \Delta x \Delta y \Delta z$

en la dirección y : $-\frac{\partial(\rho v_y)}{\partial y} \Delta x \Delta y \Delta z$

en la dirección z : $-\frac{\partial(\rho v_z)}{\partial z} \Delta x \Delta y \Delta z$

Flujo neto en las tres dimensiones:

$$-\left[\frac{\partial(\rho v_x)}{\partial x} + \frac{\partial(\rho v_y)}{\partial y} + \frac{\partial(\rho v_z)}{\partial z} \right] \Delta x \Delta y \Delta z$$

Por unidad de volumen:

$$-\left[\frac{\partial(\rho v_x)}{\partial x} + \frac{\partial(\rho v_y)}{\partial y} + \frac{\partial(\rho v_z)}{\partial z} \right]$$

Expresión que debe ser igual al cambio con el tiempo de la masa por unidad de volumen, así:

$$-\left[\frac{\partial(\rho v_x)}{\partial x} + \frac{\partial(\rho v_y)}{\partial y} + \frac{\partial(\rho v_z)}{\partial z} \right] = \frac{\partial(\rho n)}{\partial t}$$

siendo $n = \text{porosidad}$ y $\rho n = \frac{M}{V_{\text{agua}}} \cdot \frac{V_{\text{agua}}}{V_T} = \frac{M}{V_T}$

En el caso de $\rho = \text{cte.}$ y aplicando $v = -K \frac{\partial h}{\partial x}$ en cada componente:

$$\frac{\partial}{\partial x} \left(K_x \frac{\partial h}{\partial x} \right) + \frac{\partial}{\partial y} \left(K_y \frac{\partial h}{\partial y} \right) + \frac{\partial}{\partial z} \left(K_z \frac{\partial h}{\partial z} \right) = \frac{1}{e} \frac{\partial(\rho n)}{\partial t}$$

Para un medio ^{homogéneo} ~~heterogéneo~~ e isotrópico:

$$K \left[\frac{\partial^2 h}{\partial x^2} + \frac{\partial^2 h}{\partial y^2} + \frac{\partial^2 h}{\partial z^2} \right] = \frac{1}{e} \frac{\partial(\rho n)}{\partial t}$$

Para el mismo medio en condiciones de FLUJO ESTABLECIDO:

$$\left. \frac{\partial^2 h}{\partial x^2} + \frac{\partial^2 h}{\partial y^2} + \frac{\partial^2 h}{\partial z^2} = 0 \right\} \begin{array}{l} \text{ECUACION} \\ \text{DE} \\ \text{LAPLACE} \end{array}$$

Para condiciones de FLUJO TRANSITORIO:

$$\frac{\partial^2 h}{\partial x^2} + \frac{\partial^2 h}{\partial y^2} + \frac{\partial^2 h}{\partial z^2} = \frac{S_s}{K} \frac{\partial h}{\partial t}$$

donde: $\frac{1}{e} \frac{\partial(\rho n)}{\partial t} = S_s \frac{\partial h}{\partial t}$

ALMACENAMIENTO ESPECIFICO $= S_s =$ Vol. de agua liberado por unidad de área del acuífero por cambio unitario en la componente de la carga hidráulica normal a la sup. del acuífero

Caso especial de un acuífero confinado de espesor b (flujo transitorio bidimensional):

$$\frac{\partial^2 h}{\partial x^2} + \frac{\partial^2 h}{\partial y^2} = \frac{S}{T} \frac{\partial h}{\partial t}$$

donde: Transmisividad $T = kb$

Coefficiente de almacenamiento $S = S_s b$

La solución de estas ecuaciones diferenciales parciales debe ser tal que se obtenga una función del tipo:

$$h(x, y, z, t)$$

1. The Steady-State, Saturated Flow Equation:

$$\frac{\partial}{\partial x} \left(K_x \frac{\partial h}{\partial x} \right) + \frac{\partial}{\partial y} \left(K_y \frac{\partial h}{\partial y} \right) + \frac{\partial}{\partial z} \left(K_z \frac{\partial h}{\partial z} \right) = 0 \quad (1.1)$$

2. The Steady-State, Unsaturated Flow Equation:

$$\frac{\partial}{\partial x} \left(K_x(\psi) \frac{\partial \psi}{\partial x} \right) + \frac{\partial}{\partial y} \left(K_y(\psi) \frac{\partial \psi}{\partial y} \right) + \frac{\partial}{\partial z} \left(K_z(\psi) \left(\frac{\partial \psi}{\partial z} + 1 \right) \right) = 0 \quad (1.2)$$

3. The Transient, Saturated Flow Equation:

$$\frac{\partial}{\partial x} \left(K_x \frac{\partial h}{\partial x} \right) + \frac{\partial}{\partial y} \left(K_y \frac{\partial h}{\partial y} \right) + \frac{\partial}{\partial z} \left(K_z \frac{\partial h}{\partial z} \right) = S_s \frac{\partial h}{\partial t} \quad (1.3)$$

4. The Transient, Unsaturated Flow Equation:

$$\frac{\partial}{\partial x} \left(K_x(\psi) \frac{\partial \psi}{\partial x} \right) + \frac{\partial}{\partial y} \left(K_y(\psi) \frac{\partial \psi}{\partial y} \right) + \frac{\partial}{\partial z} \left(K_z(\psi) \left(\frac{\partial \psi}{\partial z} + 1 \right) \right) = C(\psi) \frac{\partial \psi}{\partial t} \quad (1.4)$$

where h is hydraulic head, K_x , K_y , and K_z are the components of saturated hydraulic conductivity in the x , y , and z coordinate directions, t is time, ψ is pressure head, $K_x(\psi)$, $K_y(\psi)$, and $K_z(\psi)$ are the components of unsaturated hydraulic conductivity, S_s is specific storage, $C(\psi)$ is specific moisture capacity.

SOLUCIONES DE LAS ECUACIONES DE FLUJO DEL AGUA SUBTERRÁNEA

(SEGÚN HUYAKORN Y PINDER, 1983)

I. MÉTODOS ANALÍTICOS

- A) SEPARACIÓN DE VARIABLES**
- B) SOLUCIONES POR SIMILITUD**
- C) TÉCNICAS DE VARIABLE COMPLEJA**
- D) TRANSFORMACIONES DE FOURIER Y LAPLACE**
- E) FUNCIONES DE GREEN**
- F) MÉTODOS DE PERTUBACIONES REGULARES Y SINGULARES**
- G) SERIES DE POTENCIAS**

II. MÉTODOS NUMÉRICOS

- A) MÉTODO DE DIFERENCIAS FINITAS**
- C) MÉTODO DE ELEMENTO FINITO**
- D) MÉTODO DE COLOCACIÓN**
- E) MÉTODO DE LAS CARACTERÍSTICAS**
- F) MÉTODO DE ELEMENTOS FRONTERIZOS
(BOUNDARY ELEMENT METHOD)**

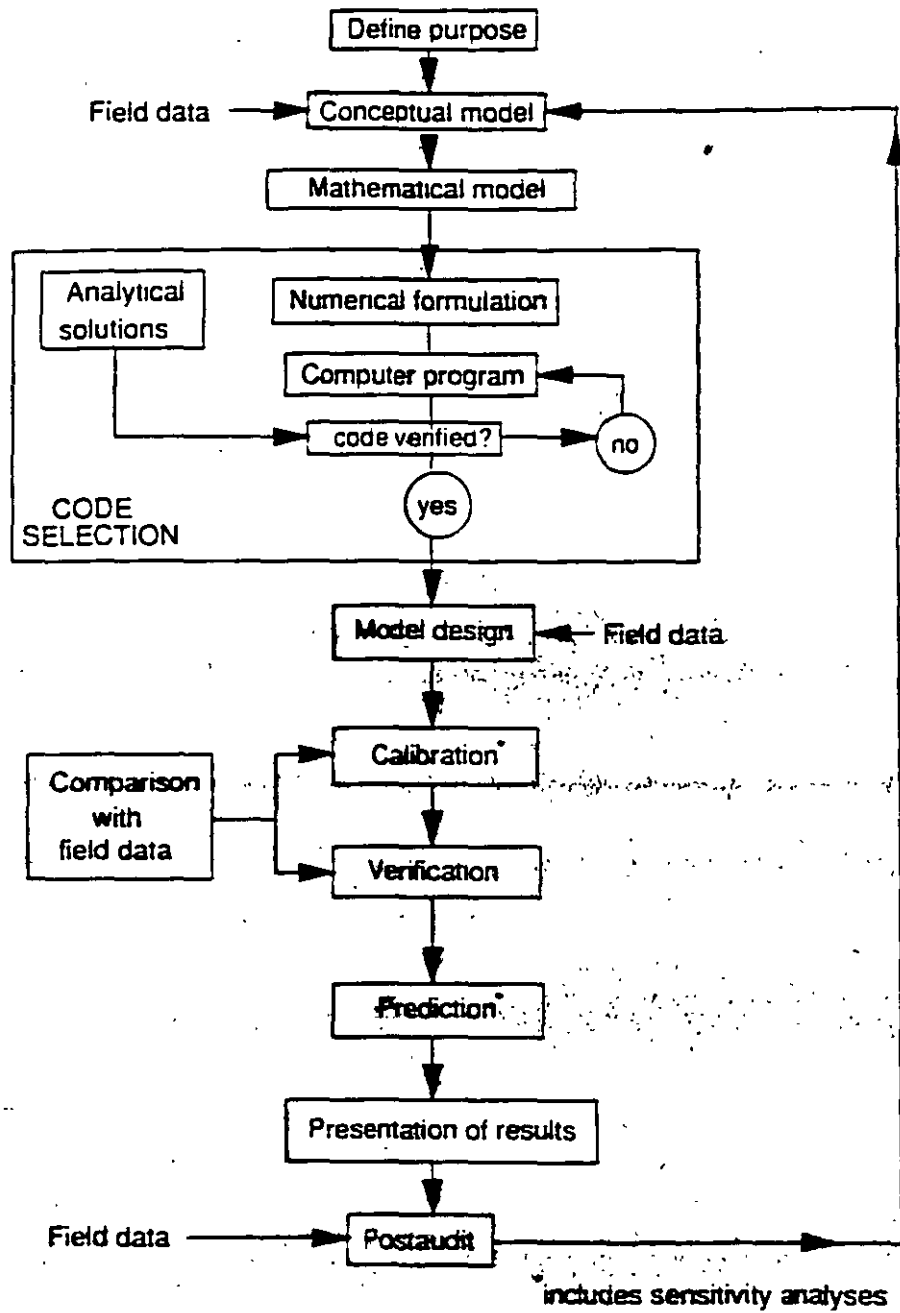

Steps in a protocol for model application.

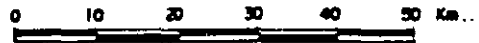
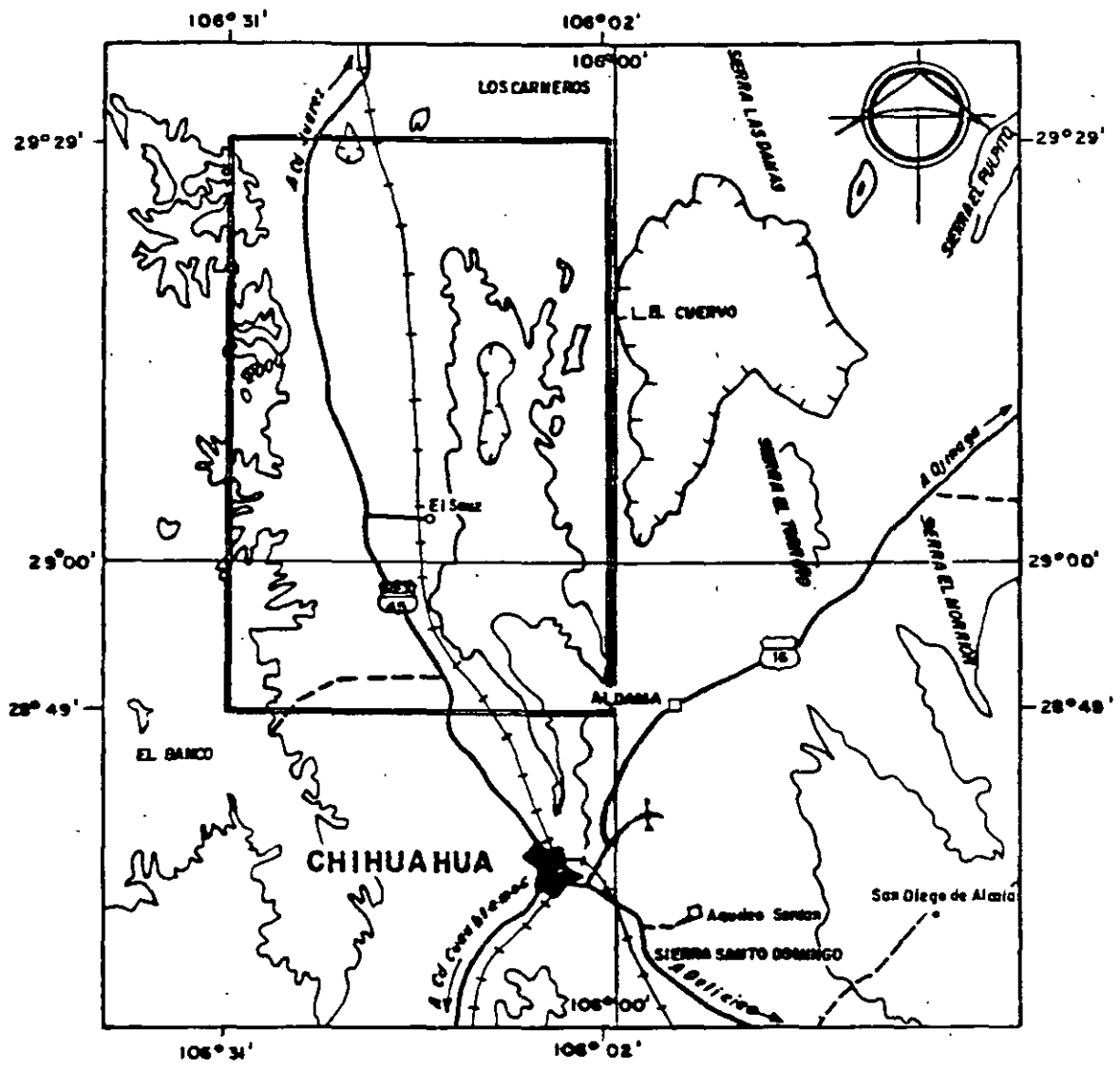

ZONA DE ESTUDIO

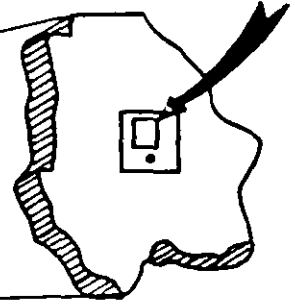

• CHIHUAHUA

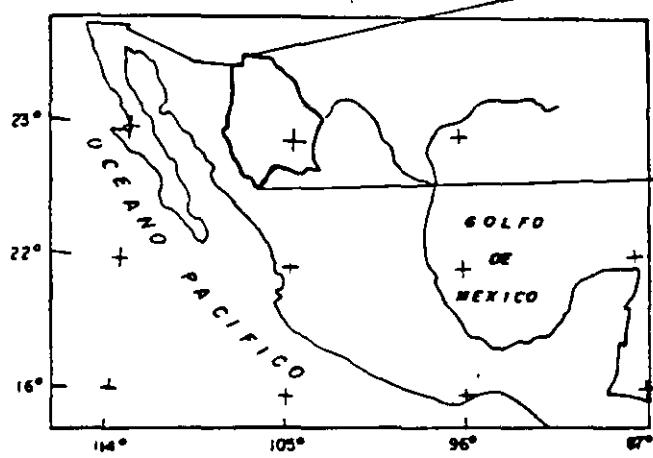

LOCALIZACION DEL AREA DE ESTUDIO

FIG. I.1.1

MODELO CONCEPTUAL DE FUNCIONAMIENTO DEL SISTEMA

SIERRA CALERA DEL NIDO

SIERRA PEÑA BLANCA

ZONA DE RECARGA SISTEMA REGIONAL

ZONA DE TRANSITO SISTEMA REGIONAL

LLUVIA = 0.4 mg/l, CI⁻

700 x 10⁶ m³/año

ZONA DE RECARGA SISTEMA INTERMEDIO

ZONA DE TRANSITO SISTEMA INTERMEDIO

ZONA DE DESCARGA SISTEMA DE FLUJO INTERMEDIO

PRESENCIA DE VEGETACION PREATOPICA

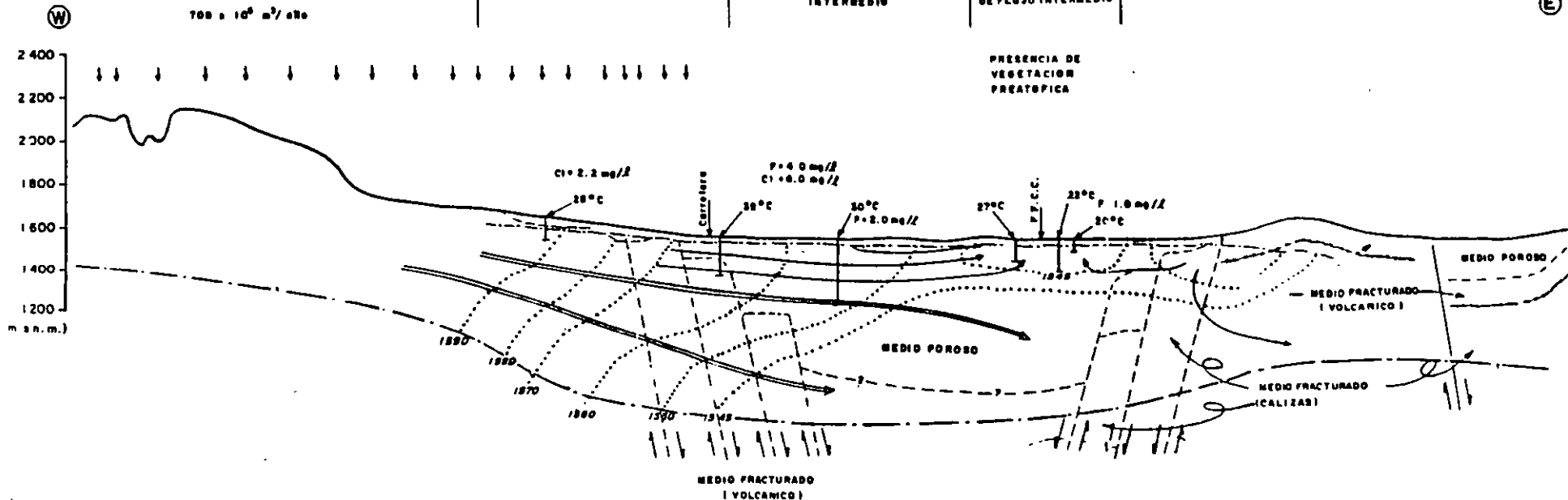

- NIVEL PREATICO
- EQUIPOTENCIAL
- SISTEMA DE FLUJO LOCAL
- SISTEMA DE FLUJO INTERMEDIO
- SISTEMA DE FLUJO REGIONAL
- /// FALLA NORMAL INFERIDA
- FRONTERA INFERIOR PROPUESTA

-9-

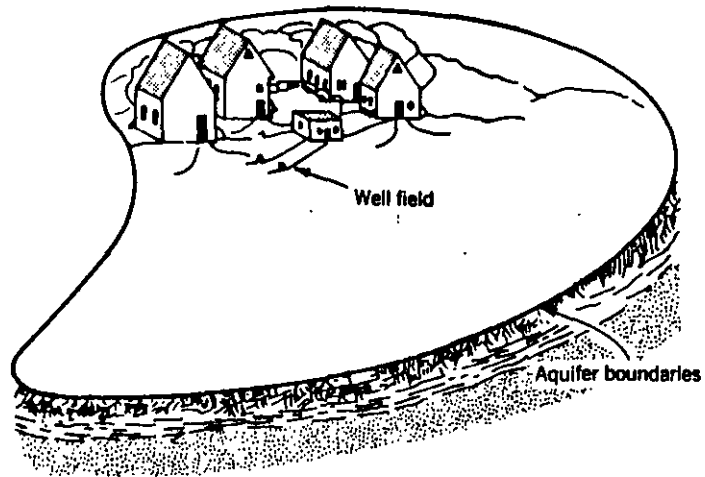

(a)

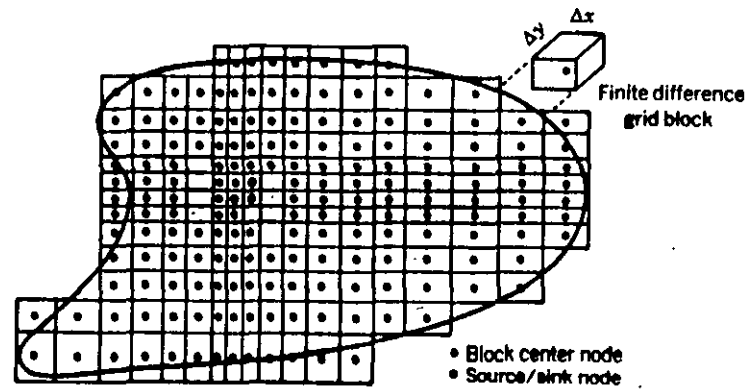

(c)

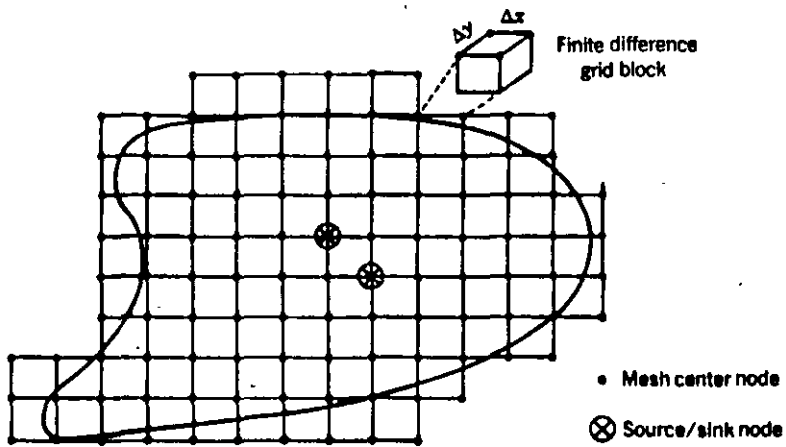

(b)

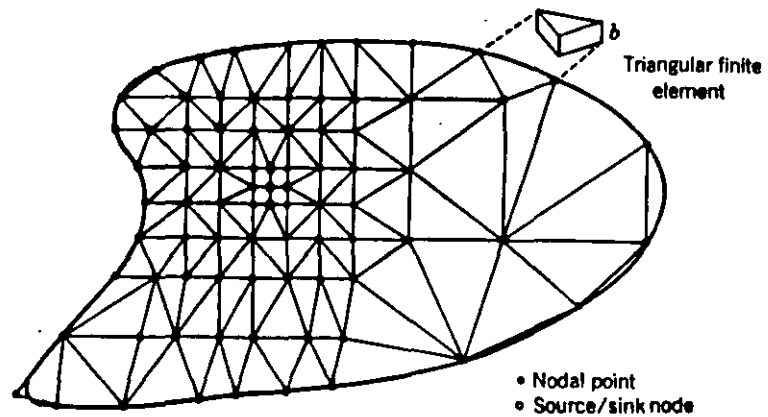

(d)

Finite difference and finite element grids (from Mercer and Faust, 1981). Reprinted by permission of Ground Water. © 1981. All rights reserved.

- 10 -

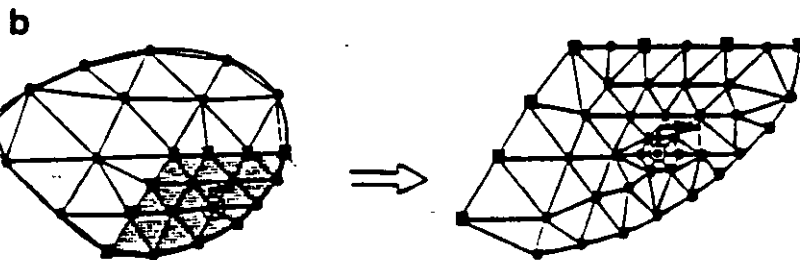
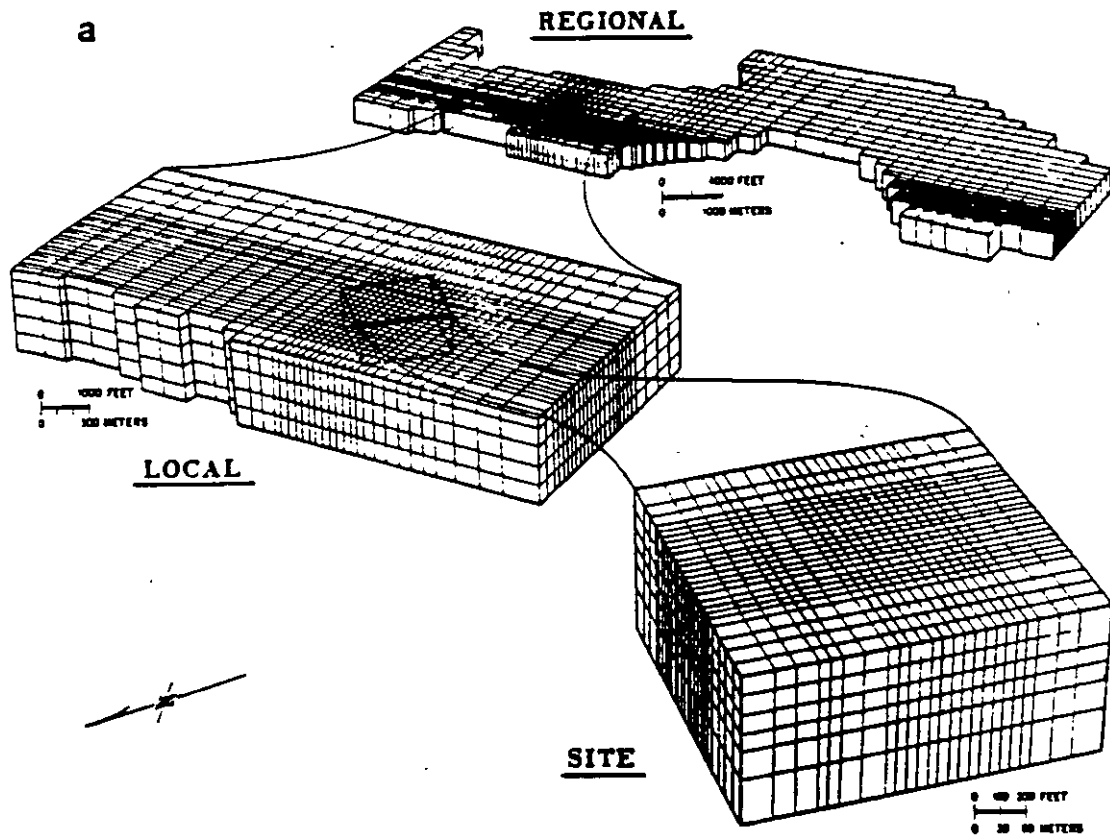

Telescopic mesh refinement.

(a) Boundaries for a regional finite difference grid are defined from information about the regional flow system. The local and site grids have hydraulic boundaries defined from simulation results (Ward, Buss, Mercer and Hughes, *Water Resources Research*, 23(4), pp. 603-617, 1987, copyright by the American Geophysical Union).

(b) Finite element grids for regional and local scale models. The grids match along the nodes shown by squares. Boundary conditions along these nodes are determined from the solution of the regional scale problem (Townley and Wilson, 1980).

one-dimension

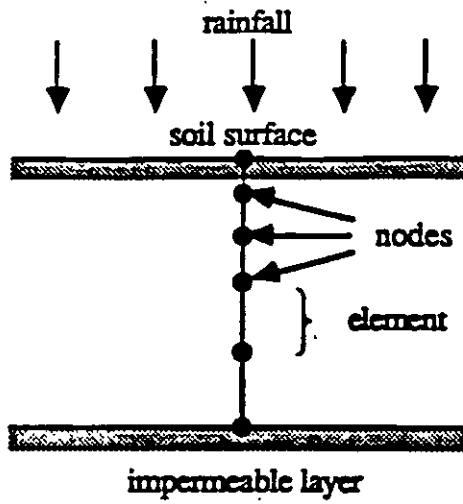

two-dimensions

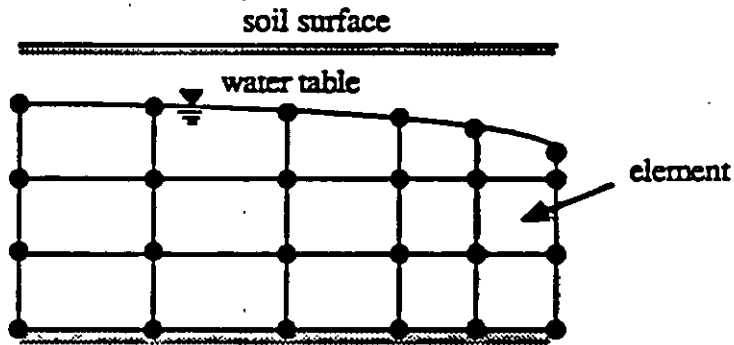

three-dimensions

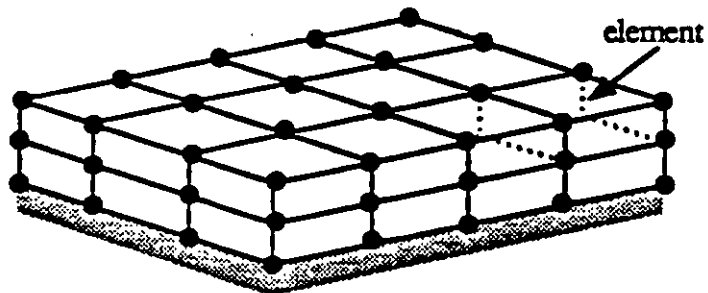

Discretization of one-, two-, and three-dimensional problem domains.

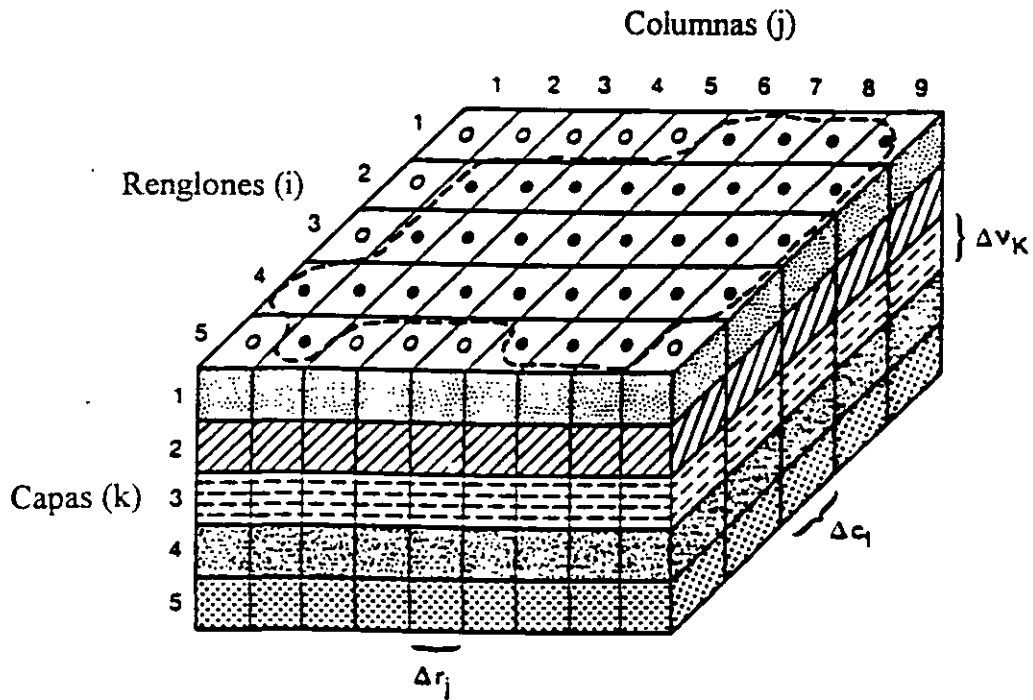

----- Fronteras del acuífero

- Celda activa
- Celda inactiva

Δr_j Dimensiones de la celda en la dirección del renglón

Δc_l Dimensiones de la celda en la dirección de la columna

Δv_k Dimensiones de la celda a lo largo de la dirección vertical

DISCRETIZACION DEL ACUIFERO

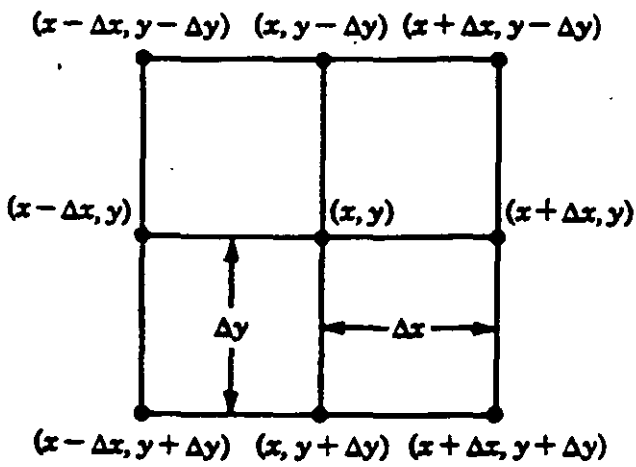

(a)

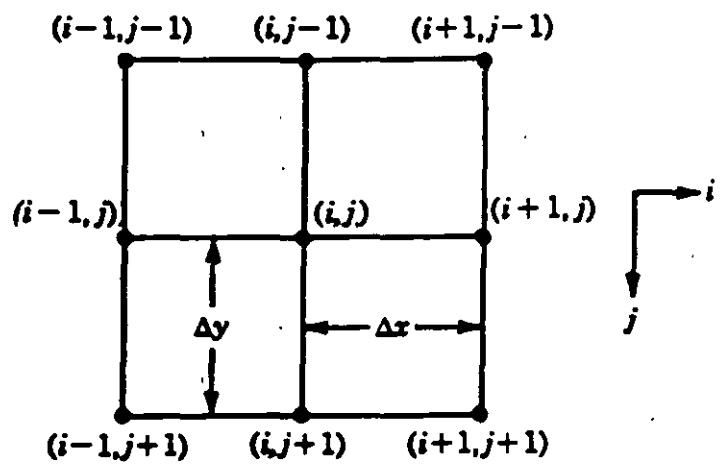

(b)

xy and *ij* notation for finite differences.

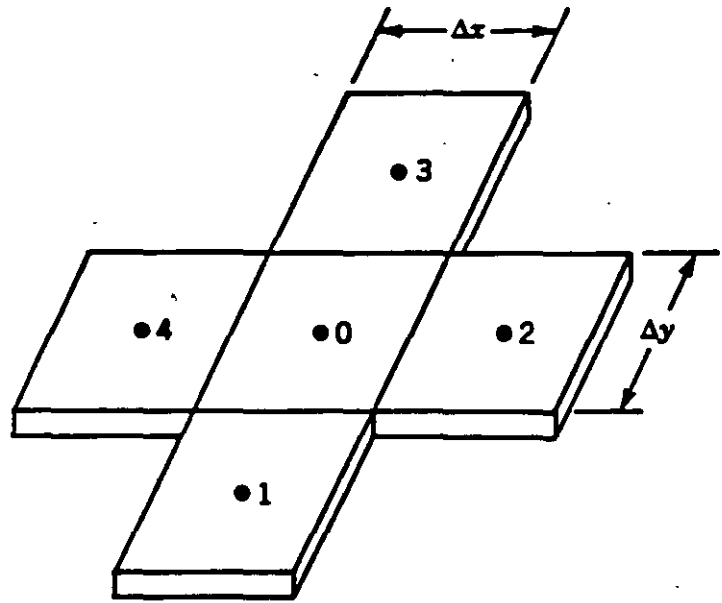

Block-centered grid.

METODO DE LAS DIFERENCIAS FINITAS

Ecuación de continuidad para una celda:

$$\sum Q_i = S_s \frac{\Delta h}{\Delta t} \Delta V \quad (1)$$

donde $Q_i =$ caudal hacia la celda $L^3 T^{-1}$
 $S_s =$ almacenamiento específico L^{-1}
 $\Delta V =$ volumen de la celda L^3
 $\Delta h =$ cambio o incremento de la carga hidráulica en el intervalo de tiempo Δt

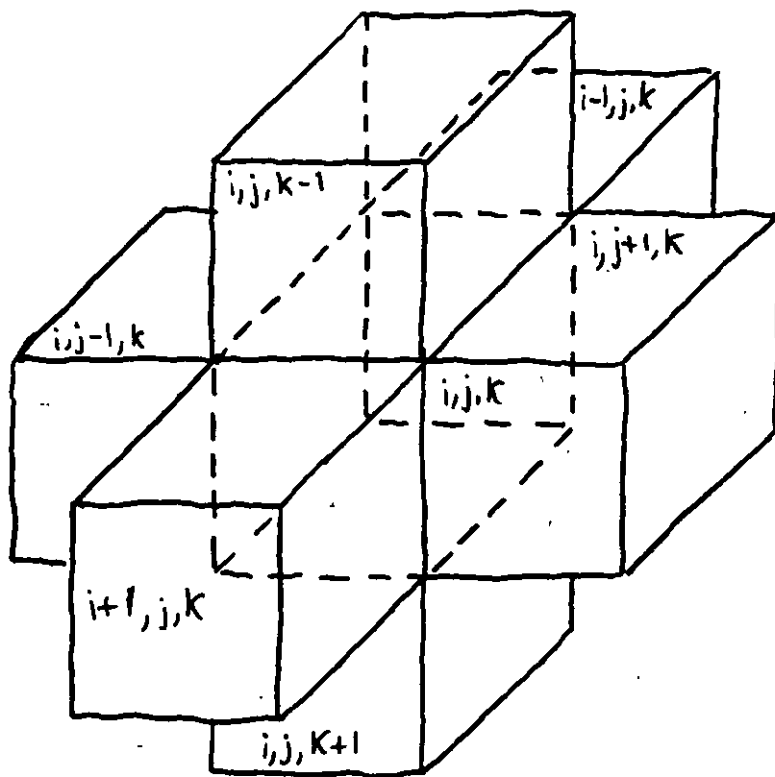

Celda i, j, k e índices de las 6 celdas adyacente

Equación del flujo hacia la celda i, j, k en dirección de las filas, proveniente de la celda $i, j-1, k$:

$$(2) \quad q_{i, j-\frac{1}{2}, k} = KR_{i, j-\frac{1}{2}, k} \Delta C_i \Delta V_k \frac{(h_{i, j-1, k} - h_{i, j, k})}{\Delta r_{j-\frac{1}{2}}} \quad (\text{Ley de Darcy})$$

Donde: $h_{i, j, k}$ = carga hidráulica en el nodo i, j, k (en L)
 $h_{i, j-1, k}$ = carga hidráulica en el nodo $i, j-1, k$ (en L)
 $q_{i, j-\frac{1}{2}, k}$ = caudal a través de la cara entre las celdas i, j, k e $i, j-1, k$ (en $L^3 T^{-1}$)

$KR_{i, j-\frac{1}{2}, k}$ = conductividad hidráulica a lo largo de la fila entre los nodos i, j, k e $i, j-1, k$ (en LT)

$\Delta C_i \Delta V_k$ = área de la celda normal a la dirección de la fila (L^2)

$\Delta r_{j-\frac{1}{2}}$ = distancia entre los nodos i, j, k e $i, j-1, k$ (L)

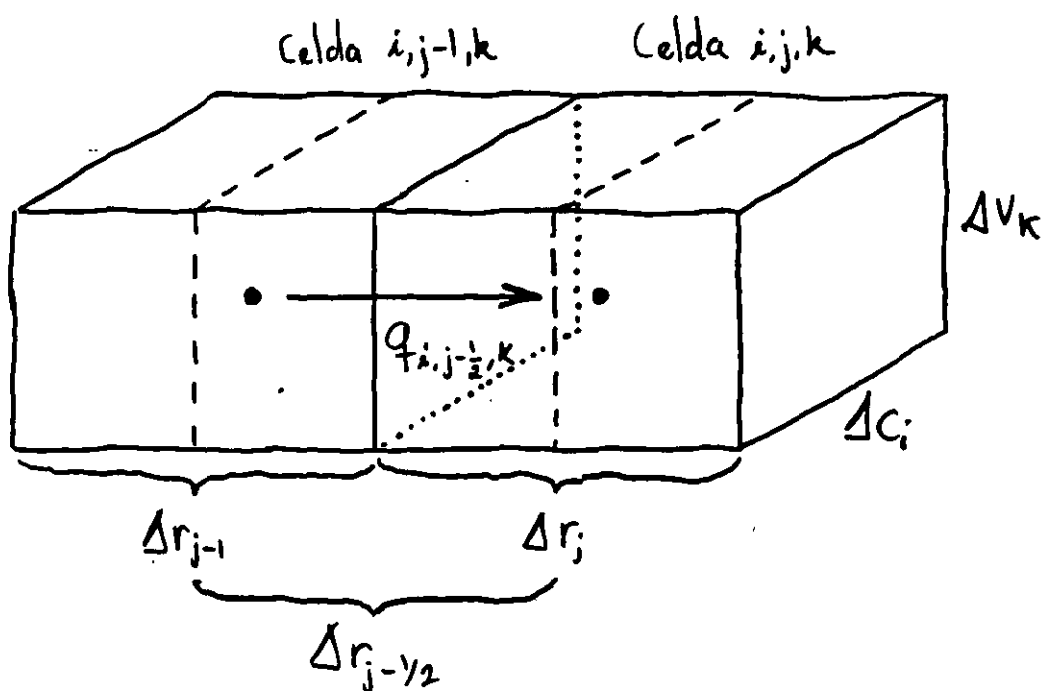

FLUJO HACIA LA CELDA i, j, k desde la celda $i, j-1, k$

Flujo en la dirección de las filas entre la celda i, j, k y la celda $i, j+1, k$:

$$q_{i, j+\frac{1}{2}, k} = KR_{i, j+\frac{1}{2}, k} \Delta C_i \Delta V_k \frac{(h_{i, j+1, k} - h_{i, j, k})}{\Delta r_{j+\frac{1}{2}}} \quad (3)$$

En dirección de la columna y de la celda $i+1, j, k$ a la celda i, j, k :

$$q_{i+\frac{1}{2}, j, k} = KC_{i+\frac{1}{2}, j, k} \Delta r_j \Delta V_k \frac{(h_{i+1, j, k} - h_{i, j, k})}{\Delta C_{i+\frac{1}{2}}} \quad (4)$$

En dirección de la columna y de la celda i, j, k a la celda $i-1, j, k$:

$$q_{i-\frac{1}{2}, j, k} = KC_{i-\frac{1}{2}, j, k} \Delta r_j \Delta V_k \frac{(h_{i-1, j, k} - h_{i, j, k})}{\Delta C_{i-\frac{1}{2}}} \quad (5)$$

En la dirección vertical, el flujo desde el fondo de la celda i, j, k :

$$q_{i, j, k+\frac{1}{2}} = KV_{i, j, k+\frac{1}{2}} \Delta r_j \Delta C_i \frac{(h_{i, j, k+1} - h_{i, j, k})}{\Delta V_{k+\frac{1}{2}}} \quad (6)$$

En la dirección vertical, el flujo hacia el techo de la celda i, j, k :

$$q_{i, j, k-\frac{1}{2}} = KV_{i, j, k-\frac{1}{2}} \Delta r_j \Delta C_i \frac{(h_{i, j, k-1} - h_{i, j, k})}{\Delta V_{k-\frac{1}{2}}} \quad (7)$$

$$\text{CONDUCTANCIA HIDRÁULICA} = K \frac{A}{l} \quad (L^2 T^{-1})$$

K = conductividad hidráulica LT^{-1}

A = área normal a la dirección del flujo (L^2)

l = longitud de la trayectoria o distancia entre nodos

Para la dirección de flujo paralela a las filas entre las celdas $i, j-1, k$ e i, j, k , la conductancia hidráulica (CR) es:

$$CR_{i, j-\frac{1}{2}, k} = KR_{i, j-\frac{1}{2}, k} \frac{\Delta c_i \Delta V_k}{\Delta r_{j-\frac{1}{2}}} \quad (8)$$

Substituyendo (8) en (2) se tiene:

$$q_{i, j-\frac{1}{2}, k} = CR_{i, j-\frac{1}{2}, k} (h_{i, j-1, k} - h_{i, j, k}) \quad (9)$$

De igual forma, las ecuaciones (3) a (7) pueden ser así reescritas:

$$q_{i, j+\frac{1}{2}, k} = CR_{i, j+\frac{1}{2}, k} (h_{i, j+1, k} - h_{i, j, k}) \quad (10)$$

$$q_{i-\frac{1}{2}, j, k} = CC_{i-\frac{1}{2}, j, k} (h_{i-1, j, k} - h_{i, j, k}) \quad (11)$$

$$q_{i+\frac{1}{2}, j, k} = CC_{i+\frac{1}{2}, j, k} (h_{i+1, j, k} - h_{i, j, k}) \quad (12)$$

$$q_{i, j, k-\frac{1}{2}} = CV_{i, j, k-\frac{1}{2}} (h_{i, j, k-1} - h_{i, j, k}) \quad (13)$$

$$q_{i, j, k+\frac{1}{2}} = CV_{i, j, k+\frac{1}{2}} (h_{i, j, k+1} - h_{i, j, k}) \quad (14)$$

Aportaciones externas.- Se expresan como:

$$a_{i,j,k,n} = P_{i,j,k,n} h_{i,j,k} + q_{i,j,k,n} \quad (15)$$

Siendo $a_{i,j,k,n}$ el flujo de la n -ésima fuente hacia la celda i,j,k (L^3T^{-1}) y $P_{i,j,k,n}$ y $q_{i,j,k,n}$ constantes de dimensiones L^2T^{-1} y L^3T^{-1} , respectivamente.

EJEMPLOS: Para el caso de recarga a través de un pozo:

$$a_{i,j,k,1} = q_{i,j,k,1} \quad , \quad n=1 \quad (16)$$

siendo $P_{i,j,k,1} = 0$ pues $h_{i,j,k}$ es independiente del flujo proveniente del pozo

Para la infiltración proveniente de un río:

$$a_{i,j,k,2} = CRV_{i,j,k,2} (R_{i,j,k} - h_{i,j,k}) \quad , \quad n=2 \quad (17)$$

siendo $R_{i,j,k}$ = la carga hidráulica del río (L)

$CRV_{i,j,k,2}$ = conductancia hidráulica del río hacia la celda i,j,k (L^2T^{-1})

Reagrupando:

$$a_{i,j,k,2} = \underbrace{-CRV_{i,j,k,2} h_{i,j,k}}_{P_{i,j,k,2} h_{i,j,k}} + \underbrace{CRV_{i,j,k,2} R_{i,j,k}}_{q_{i,j,k,2}} \quad (18)$$

(compárese con la ecuación 15)

Para el caso general de N fuentes - pérdidas externas que afecten a una celda, se tiene:

$$QS_{i,j,k} = \sum_{n=1}^N a_{i,j,k,n} = \sum_{n=1}^N P_{i,j,k,n} h_{i,j,k} + \sum_{n=1}^N q_{i,j,k,n} \quad (19)$$

o bien:

$$QS_{i,j,k} = P_{i,j,k} h_{i,j,k} + Q_{i,j,k} \quad (20)$$

donde $P_{i,j,k} = \sum_{n=1}^N P_{i,j,k,n}$ y $Q_{i,j,k} = \sum_{n=1}^N q_{i,j,k,n}$

Incluyendo $QS_{i,j,k}$ en (1) se tiene:

$$q_{i,j-\frac{1}{2},k} + q_{i,j+\frac{1}{2},k} + q_{i-\frac{1}{2},j,k} + q_{i+\frac{1}{2},j,k} + q_{i,j,k-\frac{1}{2}} + q_{i,j,k+\frac{1}{2}} + QS_{i,j,k} = SS_{i,j,k} \frac{\Delta h_{i,j,k}}{\Delta t} \Delta r_j \Delta C_i \Delta V_k \quad (21)$$

donde:

$\frac{\Delta h_{i,j,k}}{\Delta t}$ = aproximación de diferencias finitas de la derivada de la carga hidráulica respecto al tiempo (LT^{-1})

$SS_{i,j,k}$ = almacenamiento específico de la celda i,j,k (L^{-1})

$\Delta r_j \Delta C_i \Delta V_k$ = volumen de la celda i,j,k (L^3)

Substituyendo las ecuaciones (9) a (14) y la (20) en (21) se obtiene la APROXIMACION DE DIFERENCIAS FINITAS para la celda i, j, k :

$$\begin{aligned}
 & CR_{i, j - \frac{1}{2}, k} (h_{i, j - 1, k} - h_{i, j, k}) + CR_{i, j + \frac{1}{2}, k} (h_{i, j + 1, k} - h_{i, j, k}) \\
 & + CC_{i - \frac{1}{2}, j, k} (h_{i - 1, j, k} - h_{i, j, k}) + CC_{i + \frac{1}{2}, j, k} (h_{i + 1, j, k} - h_{i, j, k}) \\
 & + CV_{i, j, k - \frac{1}{2}} (h_{i, j, k - 1} - h_{i, j, k}) + CV_{i, j, k + \frac{1}{2}} (h_{i, j, k + 1} - h_{i, j, k}) \\
 & + P_{i, j, k} h_{i, j, k} + Q_{i, j, k} = \sum_{i, j, k} \Delta r_j \Delta c_z \Delta v_k \frac{\Delta h_{i, j, k}}{\Delta t} \quad (22)
 \end{aligned}$$

EVALUACION DEL TERMINO $\frac{\Delta h_{i, j, k}}{\Delta t}$

Para un tiempo t_m en el cual los términos de la ecuación (22) son evaluados se tiene:

$$\left(\frac{\Delta h_{i, j, k}}{\Delta t} \right)_m = \frac{h_{i, j, k}^m - h_{i, j, k}^{m-1}}{t_m - t_{m-1}} \quad (23)$$

Es decir, se evalúa con la carga hidráulica de la celda i, j, k obtenida en un periodo anterior t_{m-1}

Considerando la ecuación (23), la expresión de la APROXIMACION DE DIFERENCIAS FINITAS para un tiempo t_m en la celda i, j, k es:

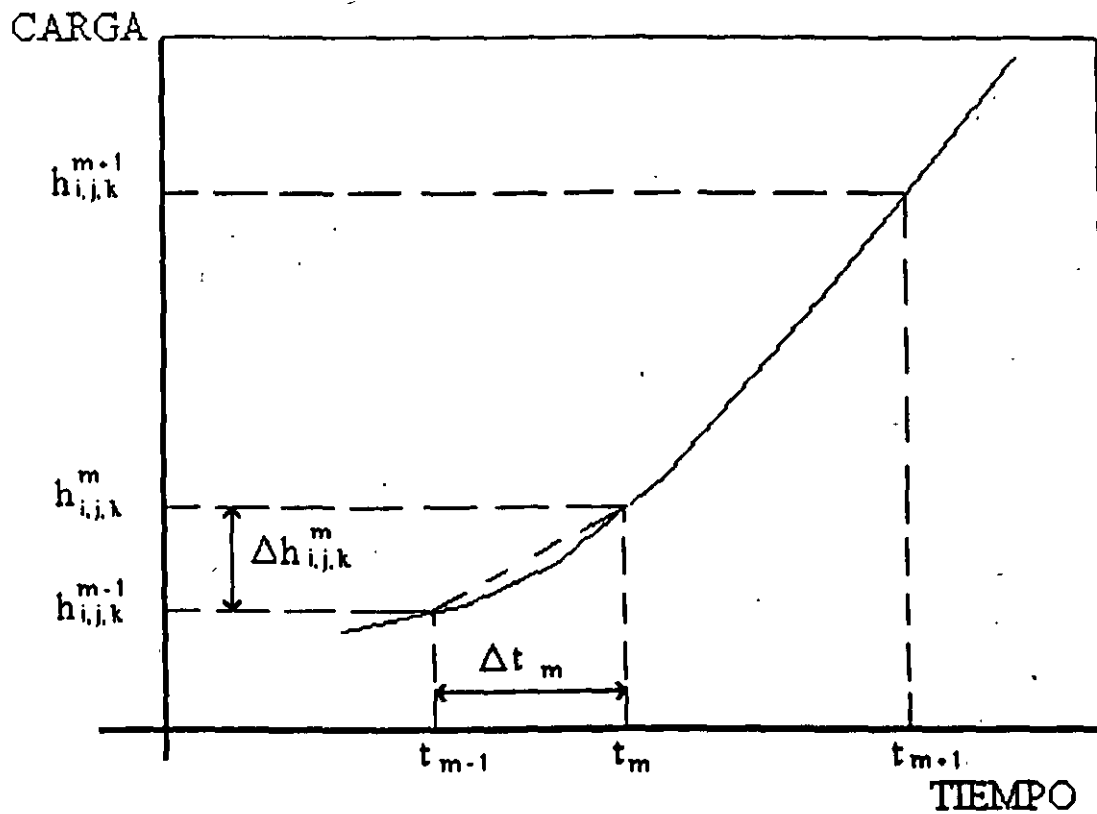

t_m Tiempo al final del intervalo de tiempo m .

$h_{i,j,k}^m$ Carga en el nodo i, j, k al tiempo t_m

----- Backward difference approximation to slope of hydrograph at time t_m .

Figura III.3 Hidrografia de la celda i, j, k .

$$\begin{aligned}
& CR_{i,j-\frac{1}{2},k} (h_{i,j+\frac{1}{2},k}^m - h_{i,j,k}^m) + CR_{i,j+\frac{1}{2},k} (h_{i,j+\frac{1}{2},k}^m - h_{i,j,k}^m) \\
& + CC_{i-\frac{1}{2},j,k} (h_{i-\frac{1}{2},j,k}^m - h_{i,j,k}^m) + CC_{i+\frac{1}{2},j,k} (h_{i+\frac{1}{2},j,k}^m - h_{i,j,k}^m) \\
& + CV_{i,j,k-\frac{1}{2}} (h_{i,j,k-1}^m - h_{i,j,k}^m) + CV_{i,j,k+\frac{1}{2}} (h_{i,j,k+1}^m - h_{i,j,k}^m) \\
& + P_{i,j,k} h_{i,j,k}^m + Q_{i,j,k} = SS_{i,j,k} (\Delta r_j \Delta c_i \Delta V_k) \frac{(h_{i,j,k}^m - h_{i,j,k}^{m-1})}{t_m - t_{m-1}} \quad (2)
\end{aligned}$$

Reagrupando:

$$\begin{aligned}
& CV_{i,j,k-\frac{1}{2}} h_{i,j,k-1}^m + CC_{i-\frac{1}{2},j,k} h_{i-\frac{1}{2},j,k}^m + CR_{i,j-\frac{1}{2},k} h_{i,j+\frac{1}{2},k}^m \\
& + (-CV_{i,j,k-\frac{1}{2}} - CC_{i-\frac{1}{2},j,k} - CR_{i,j-\frac{1}{2},k} - CR_{i,j+\frac{1}{2},k} - CC_{i+\frac{1}{2},j,k} \\
& - CV_{i,j,k+\frac{1}{2}} + \underline{HCOF}_{i,j,k}) h_{i,j,k}^m + CR_{i,j+\frac{1}{2},k} h_{i,j+\frac{1}{2},k}^m \\
& + CC_{i+\frac{1}{2},j,k} h_{i+\frac{1}{2},j,k}^m + CV_{i,j,k+\frac{1}{2}} h_{i,j,k+1}^m = \underline{RHS}_{i,j,k} \quad (25)
\end{aligned}$$

donde $HCOF_{i,j,k} = P_{i,j,k} - SC1_{i,j,k} / (t_m - t_{m-1}) \dots L^2 T^{-1}$

$RHS_{i,j,k} = -Q_{i,j,k} - SC1_{i,j,k} h_{i,j,k}^{m-1} / (t_m - t_{m-1}) \dots L^3 T^{-1}$

$SC1_{i,j,k} = SS_{i,j,k} \Delta r_j \Delta c_i \Delta V_k \dots L^2$

Expresándose en forma de matriz:

$$[A] \{h\} = \{q\}$$



siendo $[A]$ = matriz de los coeficientes de la carga hidráulica

$\{h\}$ = vector de los valores de la carga hidráulica para t_m

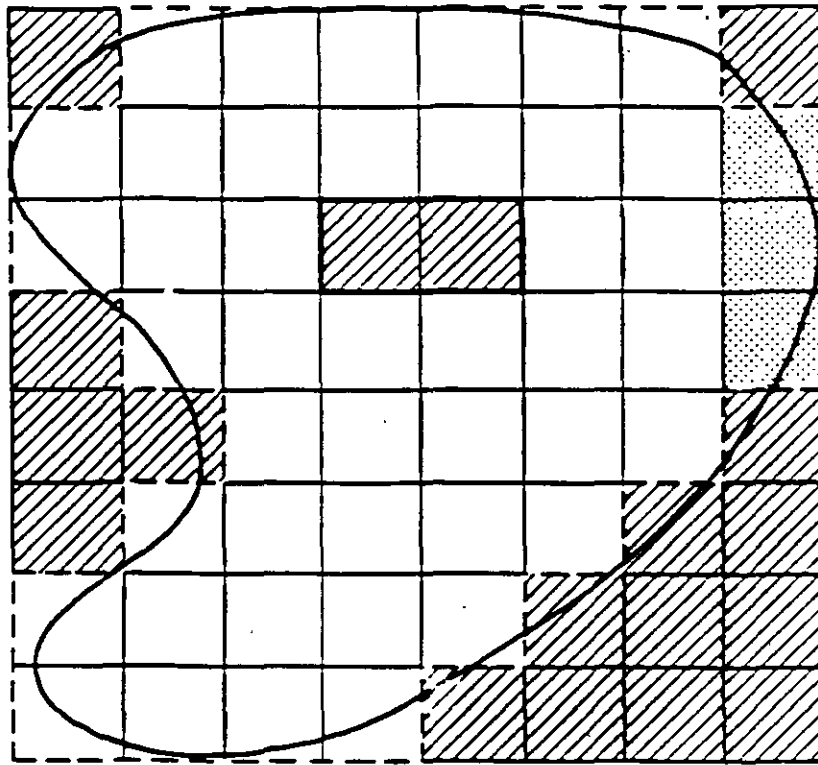
$\{q\}$ = vector de los términos constantes RHS



— Frontera del acuífero
 - - - Fronteras impermeables del modelo

 Celda inactiva
 Celdas de carga hidráulica constante
 Celdas de carga variable

DISCRETIZACION DEL ACUIFERO, MOSTRANDO SUS FRONTERAS Y LA DESIGNACION DE CELDAS.

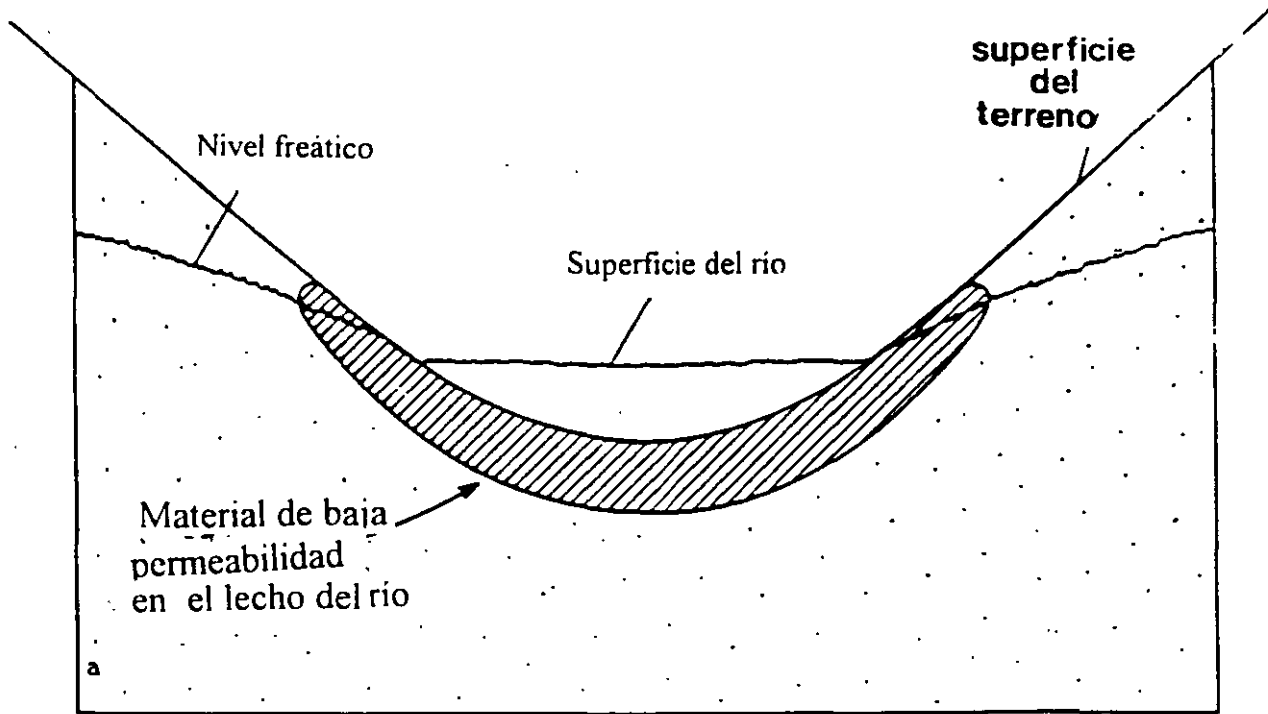

Límite de la celda

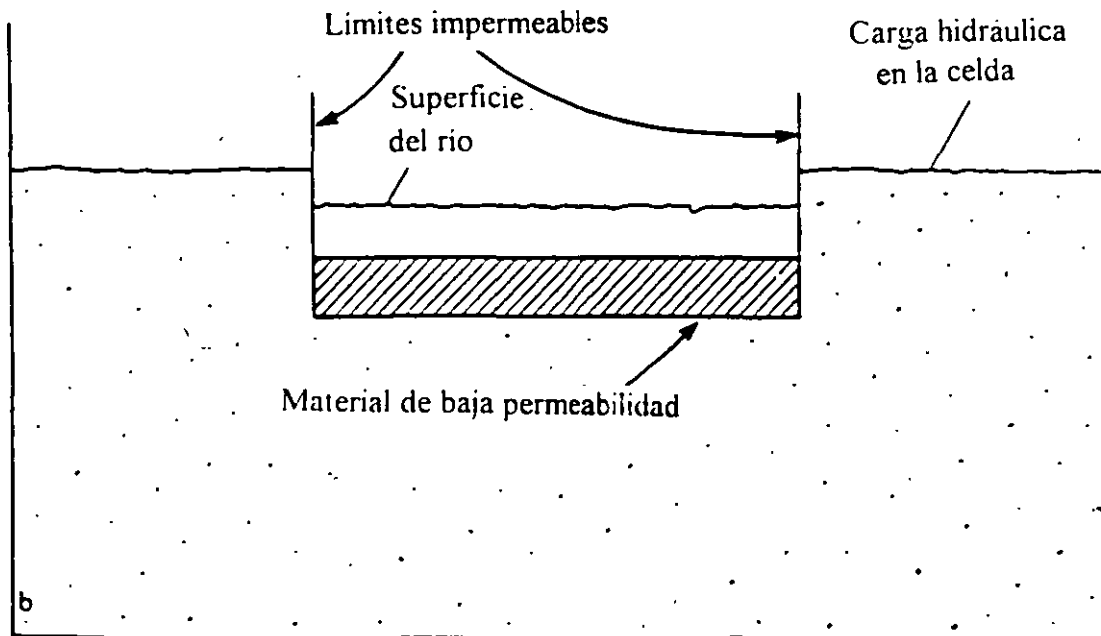

Límite de la celda

CONCEPTUALIZACION DE UN RIO



Figura III.5 Discretización de corrientes en secciones.



$$CONDUCT_{LECHO_{DEL_{RIO}}} = \frac{K * L * W}{M}$$

CALCULO DE LA CONDUCTANCIA DEL LECHO DEL RIO.

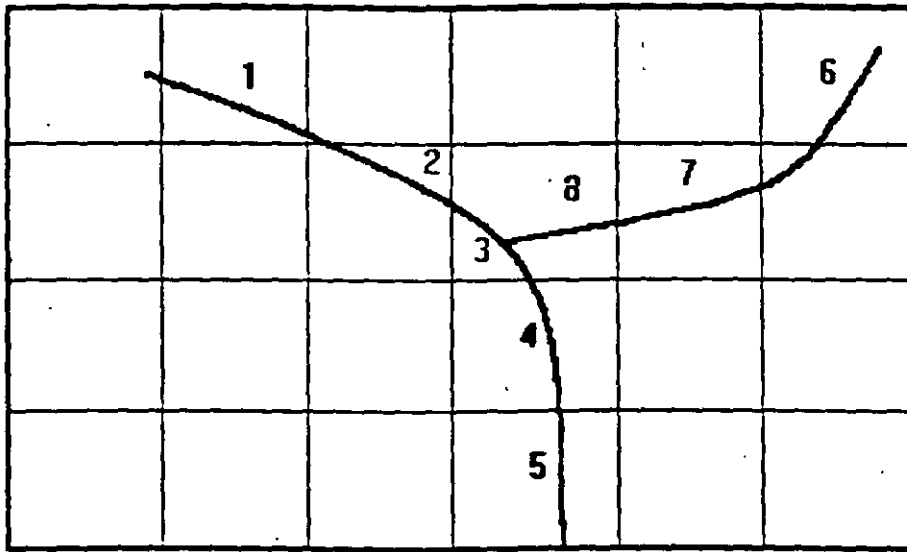
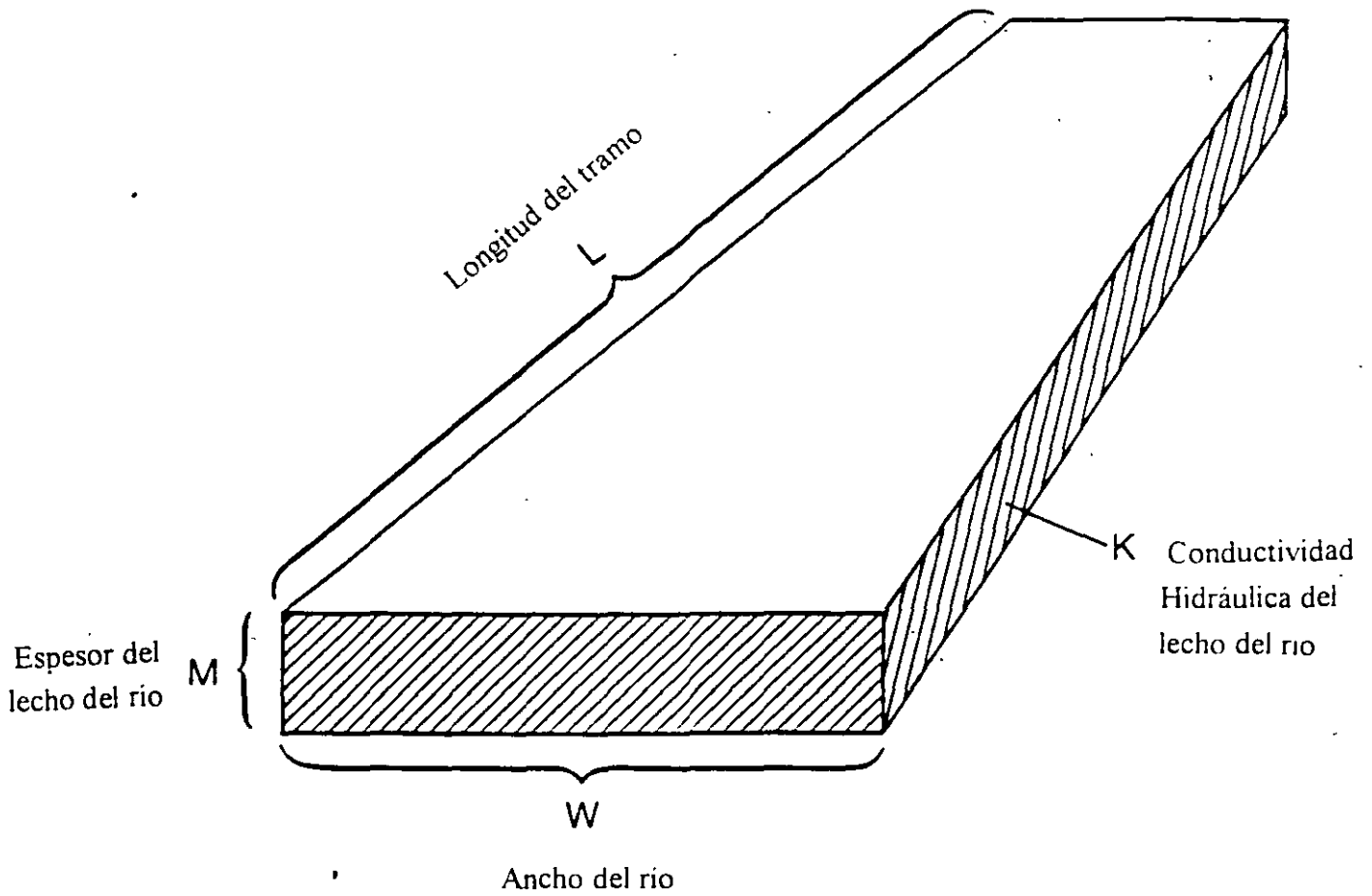
FIGURE 3.

Steady State Heads TASK 1

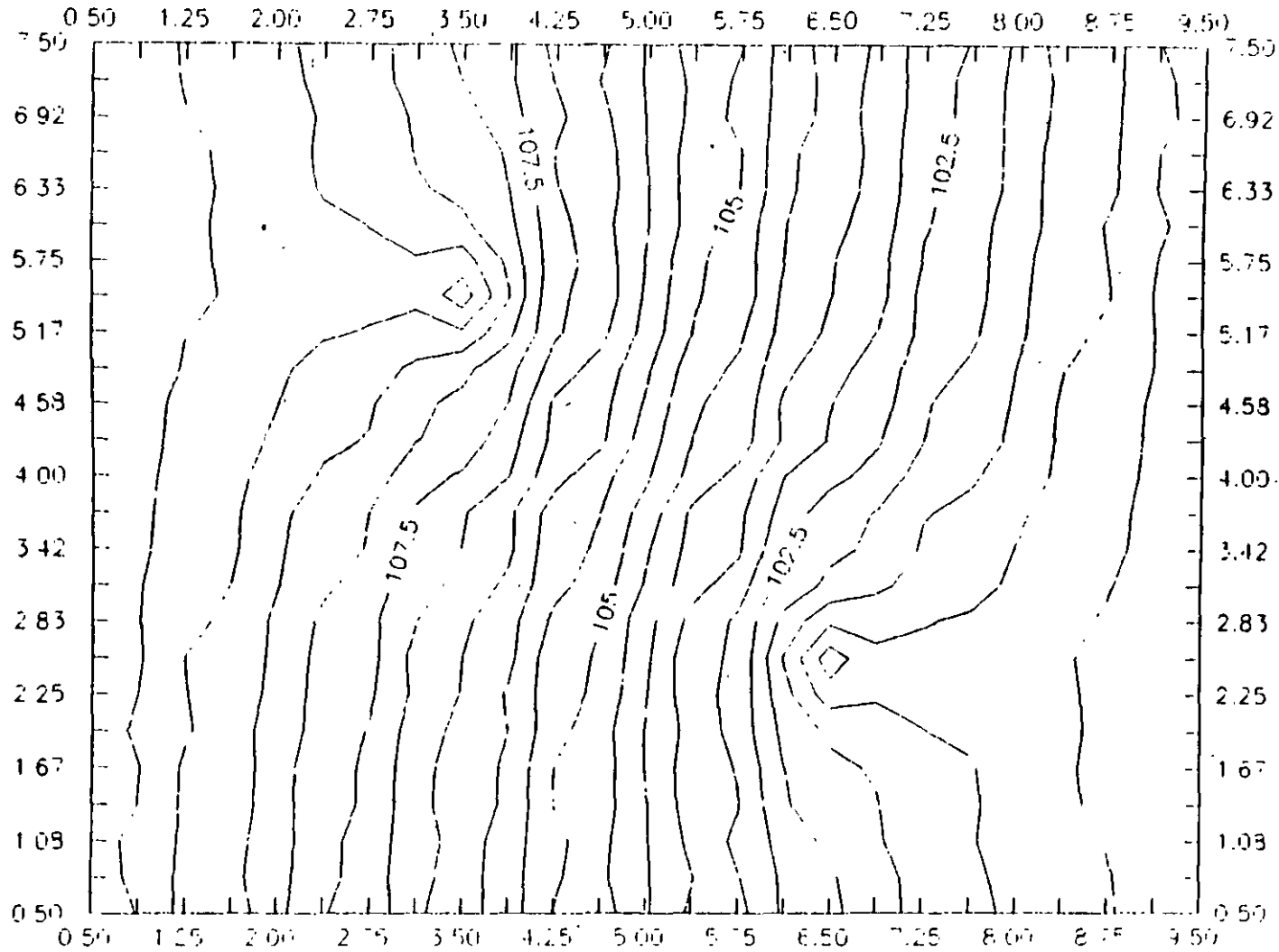

Contours in ft.

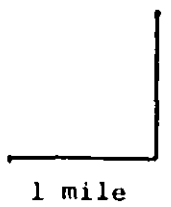

12
-28-

FIGURE 4

Transient State Heads TASK 2

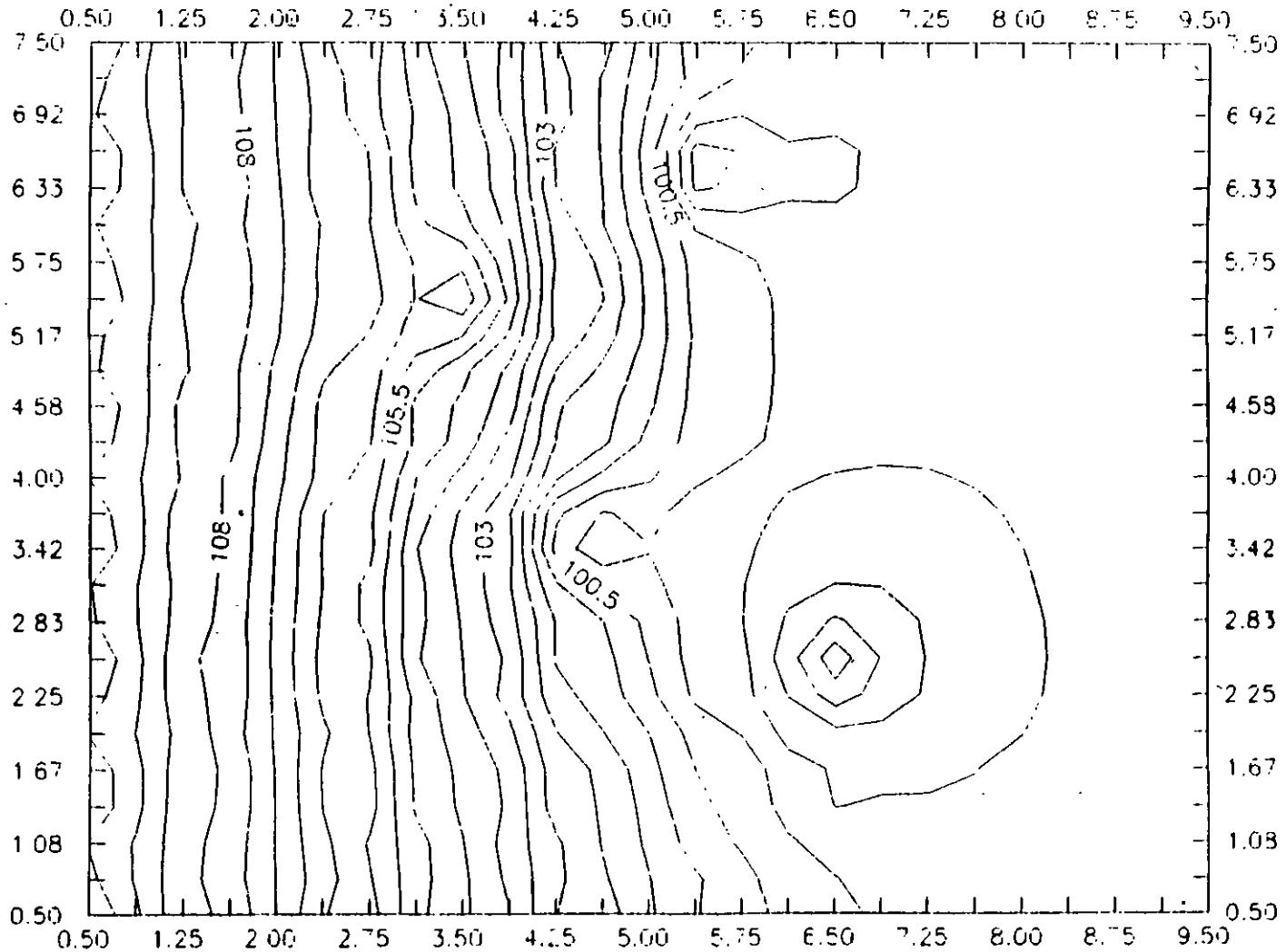

N
↑
↓
↘
↙

Contours in ft.

1 mile

13
-29-

FIGURE 5.

Transient State Heads TASK 3

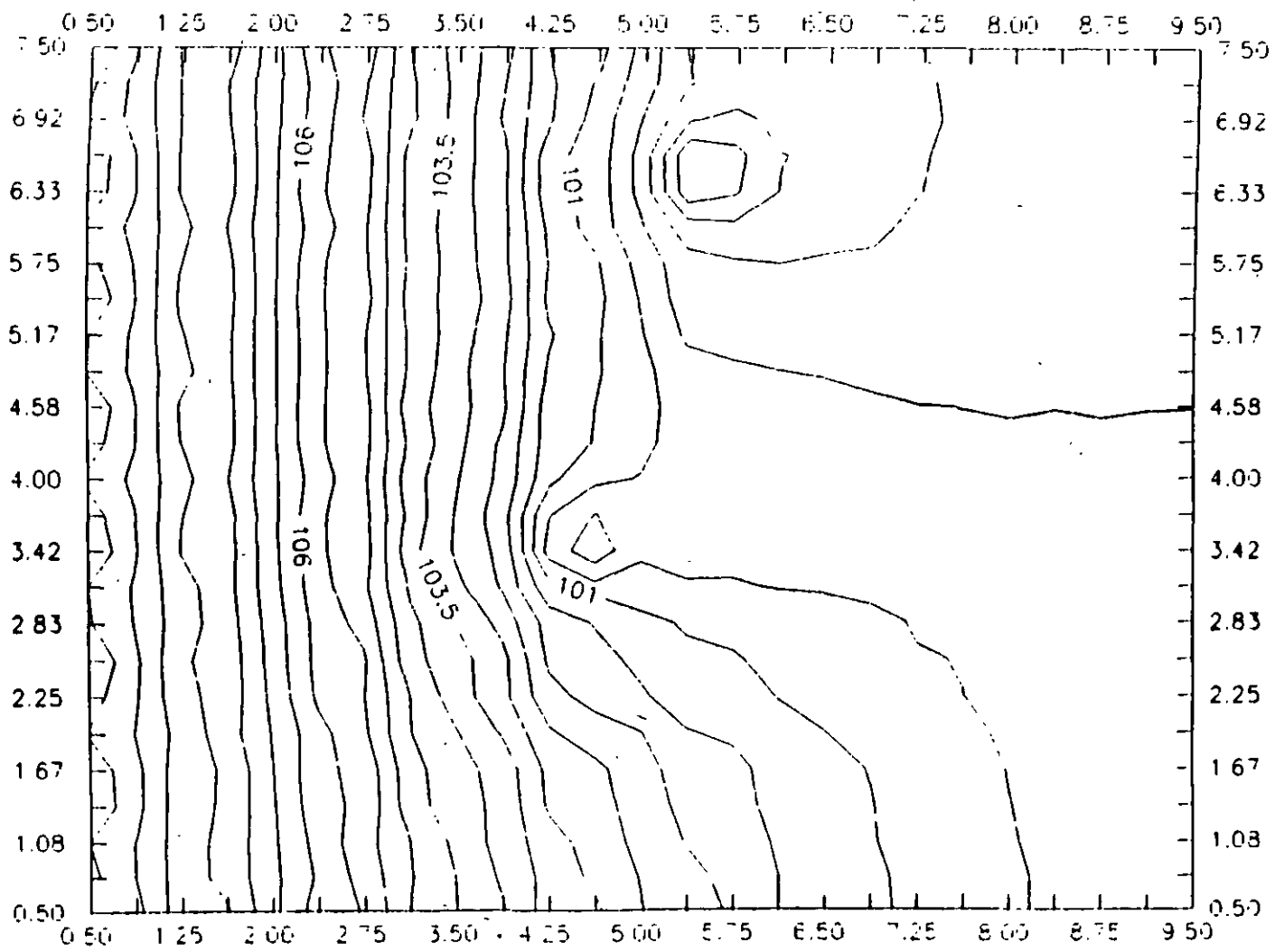

Contours in ft

1 mile

14
-30-

FIGURE 8.

Transient State Drawdowns TASK 3

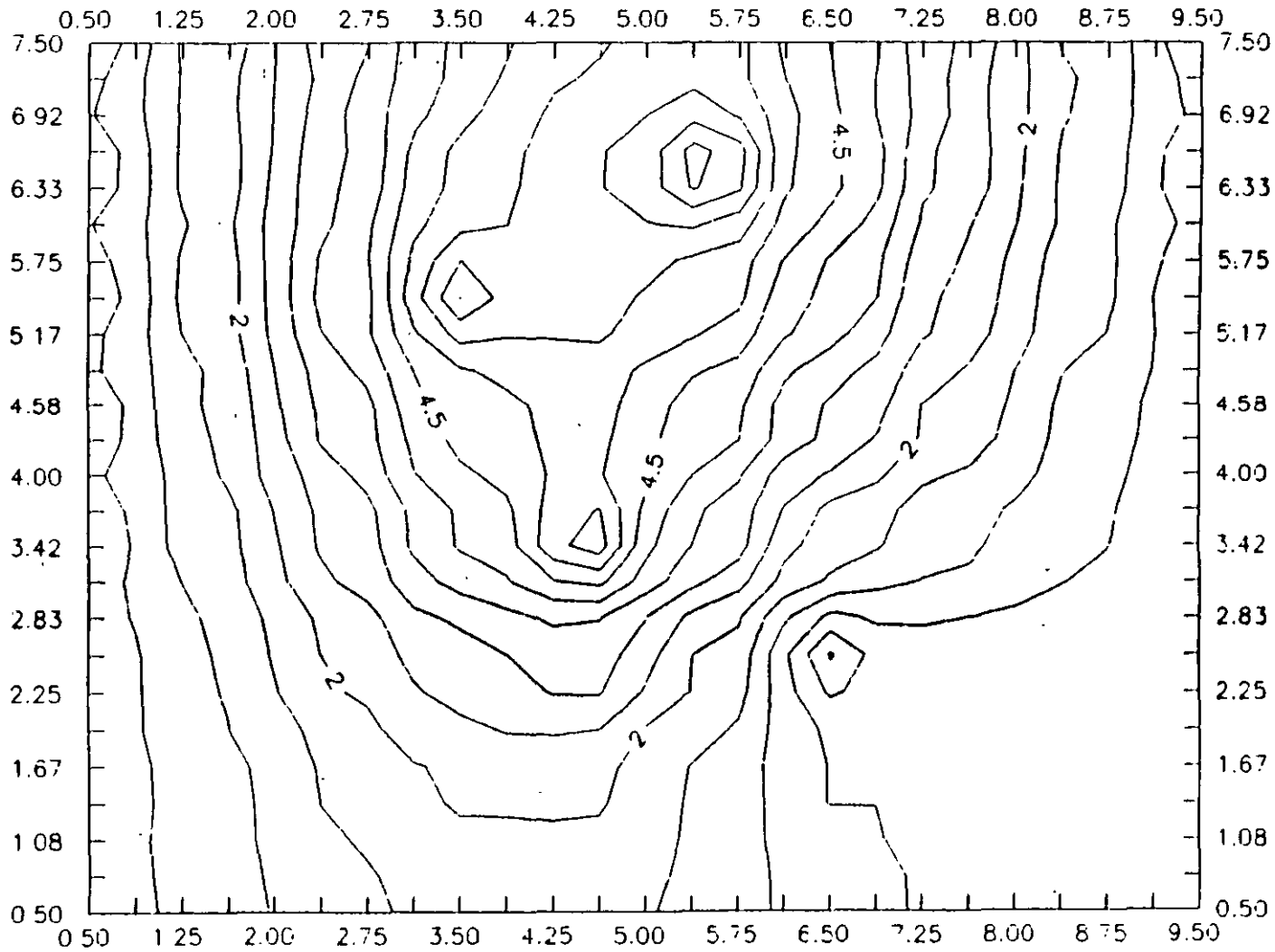

Contours in ft.

1 mile

17

- 31 -

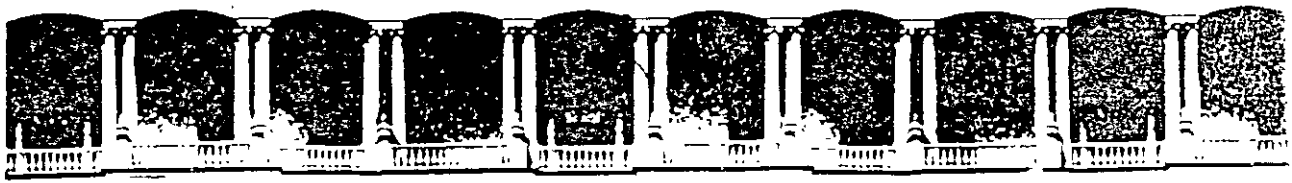

**FACULTAD DE INGENIERIA U.N.A.M.
DIVISION DE EDUCACION CONTINUA**

CURSOS ABIERTOS

**“IX CURSO INTERNACIONAL DE CONTAMINACIÓN DE
ACUÍFEROS “**

MODULO III

**MODELOS EN GEOHIDROLOGÍA Y
CONTAMINACIÓN DE ACUÍFEROS**

TEMA

HIDROLOGÍA SUBTERRANEA

EXPOSITOR : Ing. Fernando Lara Guerrero

HIDROLOGÍA SUBTERRÁNEA

La dificultad para estudiar el agua subterránea radica en que esta se encuentra bajo el subsuelo y no puede ser medida adecuadamente, en comparación con las aguas superficiales. No obstante, los principios físico-químicos que gobiernan la ocurrencia, el movimiento y la calidad del agua subterránea están bien fundamentados y permiten tener cierto grado de confianza para desarrollar predicciones acerca de su comportamiento. Cabe hacer notar que esas predicciones son solo estimaciones de la manera en la cual el agua subterránea fluye en el subsuelo.

La Hidrología subterránea no es una ciencia exacta sin embargo, es posible desarrollar un apropiado entendimiento de las características de las aguas del subsuelo si se conocen los principios y leyes básicas que rigen en esta disciplina.

Distribución del Agua en el Subsuelo

El agua bajo la superficie del terreno ocurre en dos áreas: la zona saturada y la no saturada. En la zona no saturada la mayoría de los espacios entre los poros de una roca están ocupados por aire. Sin embargo, el agua ocurre en forma de humedad en el suelo y en la franja capilar que se extiende por arriba del límite de la zona saturada. En esta el agua se encuentra a una presión hidráulica negativa, es decir menor a la atmosférica.

Por debajo de la zona saturada el agua llena completamente los poros de una roca y se encuentra a una presión mayor que la atmosférica. En términos generales el límite superior de la zona saturada, o nivel freático, sigue la superficie topográfica a cierta profundidad con respecto a la superficie del terreno. La posición de este nivel de saturación, con respecto a un punto de referencia, debe ser determinado con cuidado ya que su medición está afectada por factores.

La posición del nivel del agua en el subsuelo se puede determinar a partir de pozos de observación, pozos de explotación y piezómetros (ver Fig.). En cada uno de éstos el nivel puede ser diferente. La medición del nivel del agua en pozos que tengan diferentes profundidades es probable que refleje el nivel de uno o más acuíferos.

La fig.() muestra la diferencia de elevación del agua en diferentes pozos, cada uno de los cuales se encuentra a diferente profundidad. Cada pozo presenta diferente nivel sin embargo, el nivel freático solamente puede ser determinado en el pozo # 2. Los pozos 1 y 3-5 atraviesan estratos más profundos y cada uno tiene un ademe ranurado en diferente zona, por lo cual captan agua de diferente formación. El nivel del agua en cada aprovechamiento refleja la carga hidráulica que existe en el intervalo ranurado del pozo.

Una condición diferente se presenta en el pozo #1 debido a que el paquete de grava alrededor del pozo permite que éste capte agua de todas las formaciones. En este caso, el nivel del agua en el pozo #1 es una componente de todas las aportaciones procedentes de las zonas atravesadas.

Debido a que la carga hidráulica varía con la profundidad es muy importante poner atención en la profundidad total a la cual están terminados los pozos, así como en los detalles de su construcción. La apropiada medición del nivel del agua subterránea es importante para determinar la dirección y magnitud del gradiente hidráulico.

Acuíferos y Capas Confinantes

En el subsuelo las rocas funcionan como unidades confinantes o acuíferos. Una unidad confinante se caracteriza por su baja permeabilidad la cual no permite el fácil paso del agua a través de esta. Ejemplos de estas unidades lo representan las arcillas, limos y lutitas. Por el contrario, un acuífero es una formación geológica que posee suficiente permeabilidad para permitir el flujo a través de ésta con relativa facilidad y por tanto aporta cantidades importantes de agua para su explotación.

El agua subterránea ocurre en los acuíferos bajo dos condiciones diferentes: libre y confinado. Un acuífero libre es aquel en donde el nivel del agua representa el límite superior de la zona saturada.

En un acuífero confinado, este está limitado en su parte inferior y superior por una capa confinante y el agua en los poros posee suficiente presión para elevarse por arriba de la base de la capa confinante, si un pozo llegase a perforar esta. En algunos casos el agua posee suficiente presión para elevarse por arriba de la superficie del terreno. En estos casos los pozos se denominan brotantes o artesianos.

Porosidad y Conductividad Hidráulica

Porosidad es la relación del volumen de espacios vacíos entre el volumen total de la roca. Este define la cantidad de agua que una roca saturada puede almacenar. Conductividad hidráulica (K) expresa la facilidad con la cual el agua atraviesa una formación geológica. Este parámetro depende tanto de las características físicas del medio como del fluido de que se trate. La conductividad varía en amplio rango dependiendo del tipo de roca de que se trate y aun dentro de esta misma.

Gradiente Hidráulico

El gradiente hidráulico es la pendiente del nivel freático, es decir es el cambio en el nivel del agua por unidad de distancia, a lo largo de la dirección de máxima disminución de carga hidráulica. Este parámetro se determina midiendo el nivel del agua en varios pozos. El nivel del agua en un pozo se expresa generalmente en una elevación referida a una base que es generalmente el nivel del mar. (m.s.n.m.). Este representa la carga hidráulica total (H) la cual se compone de una carga de posición y una carga de presión (ver Fig.).

El gradiente hidráulico es la fuerza que genera el movimiento del agua subterránea en dirección de la máxima disminución de carga hidráulica.

Debido a que el nivel del agua o superficie piezométrica es un plano, la dirección del flujo subterráneo y el gradiente hidráulico se determinan a partir de la información de tres puntos (ver fig.). Estos puntos o pozos deben de cruzar el mismo acuífero, tener similar profundidad e intervalo de ademe ranurado para que las mediciones sean representativas.

Usando el método de los tres puntos, las elevaciones del nivel son calculadas para cada pozo y su localización ubicada en un mapa. Puntos de igual elevación se unen a través de líneas que forman un triángulo. Usando las elevaciones (m.s.n.m.) de cada punto, cada línea es dividida en igual número de segmentos. Seleccionando puntos de igual elevación se pueden trazar líneas equipotenciales o de contorno a través de los puntos.

Las líneas de flujo se construyen de tal forma que estas intersectan a líneas equipotenciales en un ángulo recto. Asimismo, se muestra que el agua subterránea fluye en dirección hacia donde decrece la carga hidráulica.

Mapas de Elevación del Nivel Estático

Los mapas de elevación del nivel estático, o piezométricos, son una parte esencial de cualquier estudio relacionado con las aguas subterráneas ya que estos permiten

indicar la dirección hacia la cual se mueve el agua del subsuelo y estimar el gradiente hidráulico el cual controla a su vez la velocidad del fluido.

Un mapa piezométrico es una representación gráfica del gradiente hidráulico. Este se elabora ubicando los niveles estáticos en un mapa base y uniendo puntos de igual elevación en m.s.n.m. Los contornos del nivel del agua son llamados líneas equipotenciales e indican que el agua tiene el potencial para elevarse hasta tal posición. En el caso de los acuíferos confinados, el agua tiene el potencial para elevarse a una cierta posición, pero en realidad no lo puede hacer a menos que la capa confinante sea atravesada por un pozo. Por lo tanto, la superficie piezométrica de un acuífero confinado representa una línea imaginaria.

La elaboración de un mapa piezométrico implica ubicar los niveles del agua en m.s.n.m en un mapa base y después unir puntos de igual elevación de acuerdo con ciertos criterios hidrogeológicos. Un considerable número de pozos se requiere para la elaboración un mapa piezométrico adecuado y una de las consideraciones más importantes en la elaboración de éstos es que las mediciones del nivel deben corresponder a un solo sistema de flujo subterráneo.

Errores Comunes en la Elaboración e Interpretación de Mapas Piezométricos

La configuración de un mapa piezométrico no es una tarea mecánica. Por el contrario, para su elaboración se requiere contar con ciertos criterios para decidir la mejor configuración que represente la elevación del nivel en el área. Especialmente cuando los datos de las elevaciones no siguen un determinado patrón. Por ejemplo, si los niveles medidos en los pozos provienen de varios sitios distantes entre si los datos pueden haber sido obtenidos en diferentes tiempos y no ser comparables. Si por el contrario los datos fueron tomados en el mismo intervalo de tiempo, a fin de reducir variaciones estacionales, será necesario conocer las características constructivas de cada pozo para explicar posibles anomalías en sus valores.

Si un valor anómalo no puede ser identificado rápidamente entonces será necesario realizar otras actividades de campo a fin de determinar las características hidrogeológicas que generan dicha anomalía.

Errores en la Configuración de Mapas Piezométricos

El punto de inicio para elaborar un mapa piezométrico es un mapa base de la zona de estudio. Este permite ubicar los pozos, determinar su elevación en m.s.n.m., características geográficas, geológicas, topográficas e hidrográficas, entre otras.

El trazo de las líneas equipotenciales requiere de ciertas habilidades ya que es muy común cometer dos tipos de errores como: i) Incluir mediciones de niveles no representativos del sistema de flujo subterráneo y ii) no considerar las características del subsuelo (homogeneidad y anisotropía) que pueden modificar la distribución de las líneas equipotenciales.

A continuación se enumeran varias fuentes de error en la configuración de los niveles estáticos:

1. Incluir mediciones de nivel de pozos ubicados en zonas de recarga o descarga del acuífero.
2. No considerar la distribución y las características de los cuerpos de agua superficial. Ver Fig.()
3. No considerar la presencia de estructuras o rasgos geológicos importantes. La fig.() muestra como los métodos convencionales de contorno configuran los niveles de agua de una zona dividida por una falla geológica generando configuraciones que no representan apropiadamente esta condición.
4. Considerar anomalías en la configuración de los niveles generados por la presencia de recarga o descarga artificial de agua subterránea provocada por actividades humanas. Los pozos en operación generan un cono de depresión alrededor de estos, creando una pendiente en el gradiente hidráulico. Por otra parte, los retornos de riego, recarga inducida por infiltración de aguas residuales o fugas en el sistema de agua potable, generan montículos en los mapas piezométricos de forma contraria a los observados en las zonas de bombeo.

5. Omitir posibles variaciones estacionales u otras fluctuaciones de corto tiempo que afectan el nivel del agua subterránea. Si un acuífero es sensible a las variaciones estacionales o a los períodos de lluvia o estiaje, que provocan un incremento o disminución en la elevación del nivel, entonces las mediciones en los pozos no serán representativas a menos que estas se realicen en una misma época del año.

6. Considerar mediciones del nivel en pozos que atraviesan diferentes acuíferos. En los pozos cuyo ademe ranurado atraviesa diferentes acuíferos, generalmente las medidas del nivel no son representativas de un solo acuífero. Lo anterior, se debe a que el nivel refleja la interacción de diferentes acuíferos.

Errores en la Determinación de la Dirección del Flujo Subterráneo

La dirección del flujo subterráneo en un medio isótropo es perpendicular a las líneas equipotenciales. Sin embargo, el no considerar la anisotropía y la heterogeneidad del subsuelo puede provocar errores en la determinación de la dirección del flujo. Ver figuras (y).

Redes de Flujo

Un mapa de superficie piezométrica puede ser transformado en una red de flujo subterráneo construyendo líneas de flujo que intersectan a las equipotenciales en ángulos rectos. Las líneas de flujo son caminos imaginarios que pueden seguir las partículas del agua cuando estas se mueven a través del acuífero. Aun cuando existe un número infinito de líneas equipotenciales y de flujo estas se construyen con una diferencia uniforme, de tal forma que las combinaciones de ambas forman una serie de cuadrados casi perfectos. La construcción de redes de flujo, junto con la aplicación de la ley de Darcy (ver próxima sección), permite estimar la cantidad de agua que cruza en una determinada área del subsuelo.

Por otra parte el agua subterránea no solo fluye a través de los acuíferos sino también en las capas confinantes. En este caso el flujo lateral es muy pequeño comparado con los acuíferos. Sin embargo, la infiltración vertical de ellos puede ser importante.

Ley de Darcy

La ley de Darcy es el principio básico que rige el movimiento de las aguas subterráneas. Esta ley se utiliza para calcular la cantidad de flujo que cruza determinada área en el subsuelo y se expresa como:

$$Q = A q = A K i$$

donde

Q = cantidad de flujo (L^3/T)

A = Área transversal a través de la cual ocurre el flujo

K = Conductividad Hidráulica (L^2)

i = gradiente Hidráulico (L/L)

q = velocidad de darcy (L/T)

La velocidad del flujo es directamente proporcional a el gradiente hidráulico y por tanto el flujo es laminar. Esto significa que el agua seguirá distintas líneas de flujo en lugar de mezclarse con otras líneas. En los casos en donde no se presenta el flujo laminar, por ejemplo en rocas con fracturas, cavernas de disolución o cerca de los pozos, el flujo es turbulento. En la fig () se presenta un ejemplo de la aplicación de la ley de Darcy. Cierta cantidad de flujo (Q) atraviesa un tubo relleno de arena con un área transversal (A). El nivel del agua decrece a medida que recorre la distancia (L) y la carga hidráulica es más alta en el manómetro al inicio de la trayectoria que al final de esta.

La diferencia en la carga (H) a lo largo de la trayectoria (L) es el gradiente hidráulico (H/L) o i . La pérdida de carga refleja la energía que se requiere para mover el fluido a una determinada distancia. Si la Q y A son constantes y K se incrementa, la pérdida de carga disminuye. Es importante remarcar que la pérdida de carga ocurre en la dirección del flujo.

En la fig. () el flujo en el tubo se ha invertido y el flujo fluye de la parte inferior a la superior y Q , K , A y i permanecen iguales. Lo anterior permite ilustrar un importante

concepto cuando los manómetros son considerados como pozos. Cabe destacar que el pozo profundo tiene una carga que es más alta que el pozo somero cuando el agua se mueve hacia arriba y que esta situación se invierte cuando el flujo es descendente. Cuando pozos cercanos con diferente profundidad y niveles de agua se presentan en el campo, ver fig.(), esto indica la existencia de zonas de recarga o descarga. En zonas de recarga, los pozos someros tendrán mayor carga hidráulica que los pozos profundos.

En sitios donde el flujo es horizontal no se aprecian diferencias de carga importantes. En zonas de descarga, los pozos más profundos tendrán mayor carga hidráulica.

Ejemplo

Considere un acuífero en un medio granular (arena) con un espesor promedio de 100 m. EL acuífero es cubierto por una capa confinante. La diferencia de nivel entre dos pozos separados 2 km entre si, es de 10 m y la conductividad hidráulica de la areana es de 10 m/día. Calcule la cantidad de agua que atraviesa una sección transversal del acuífero.

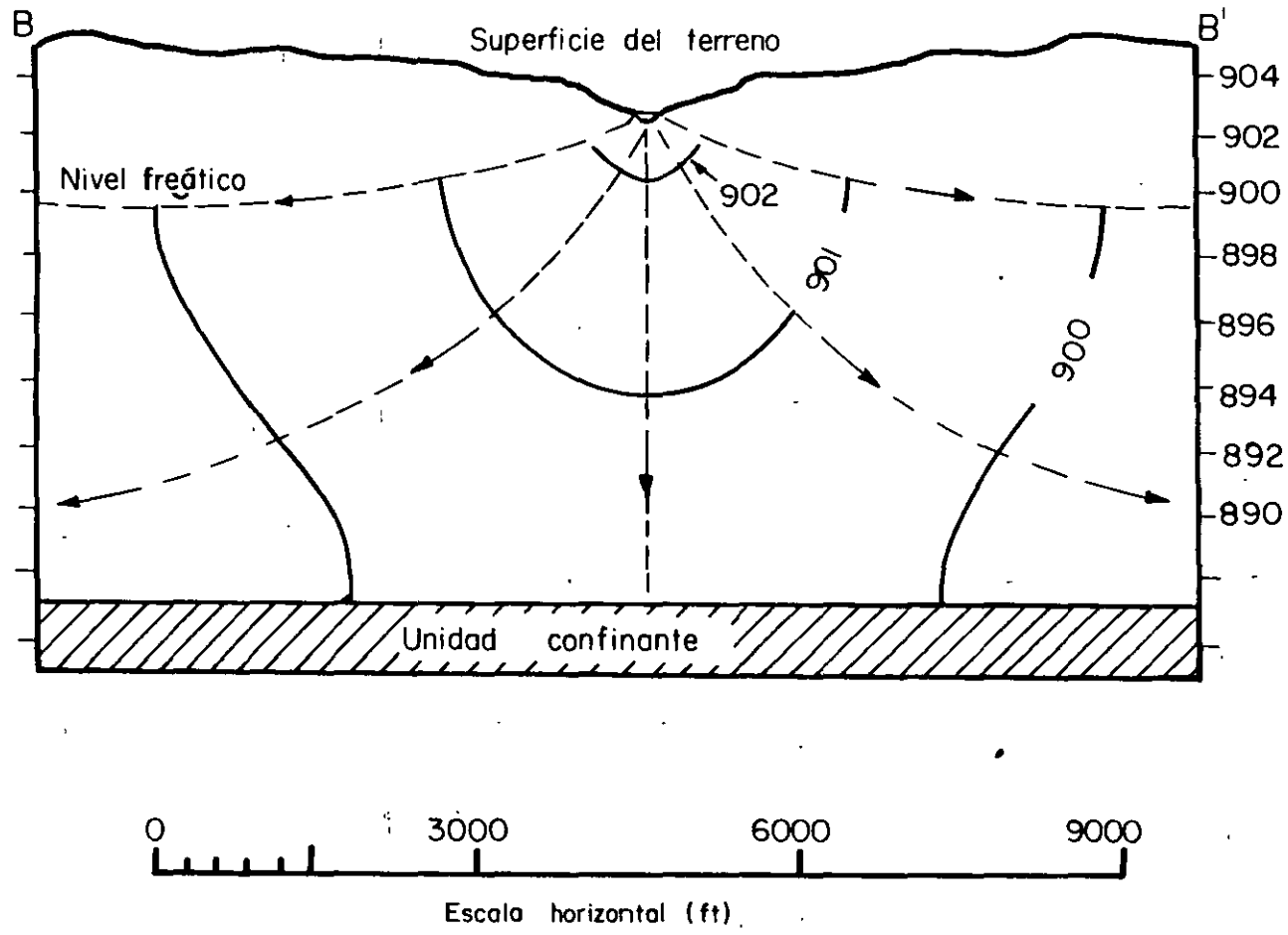

Red de flujo vertical de un acuífero libre (Heath, 1983)

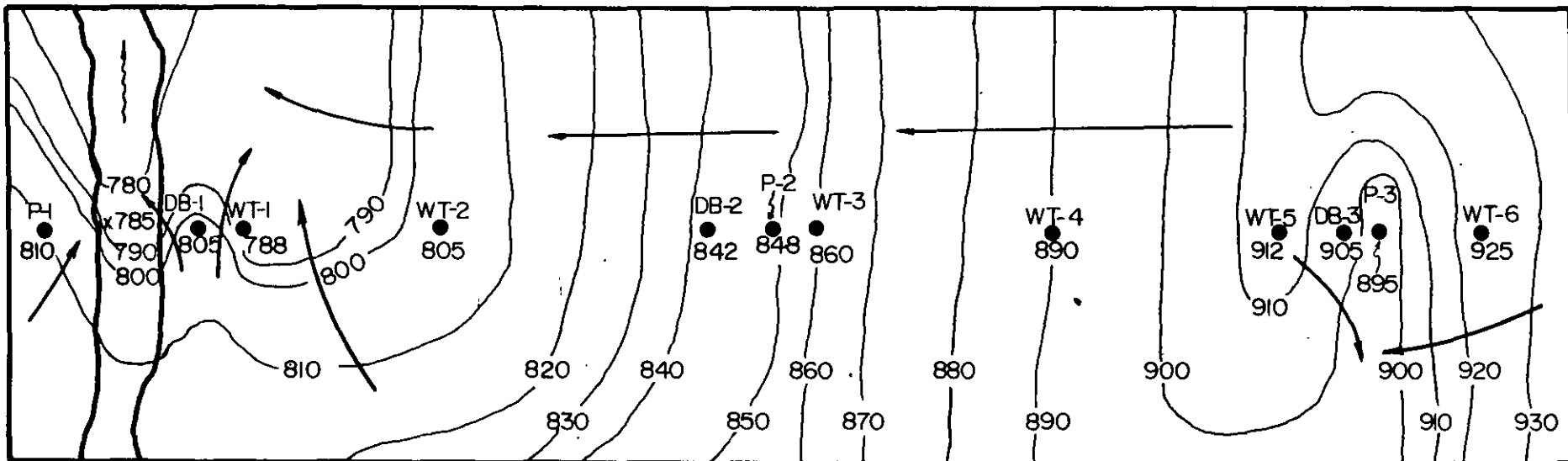

(a)

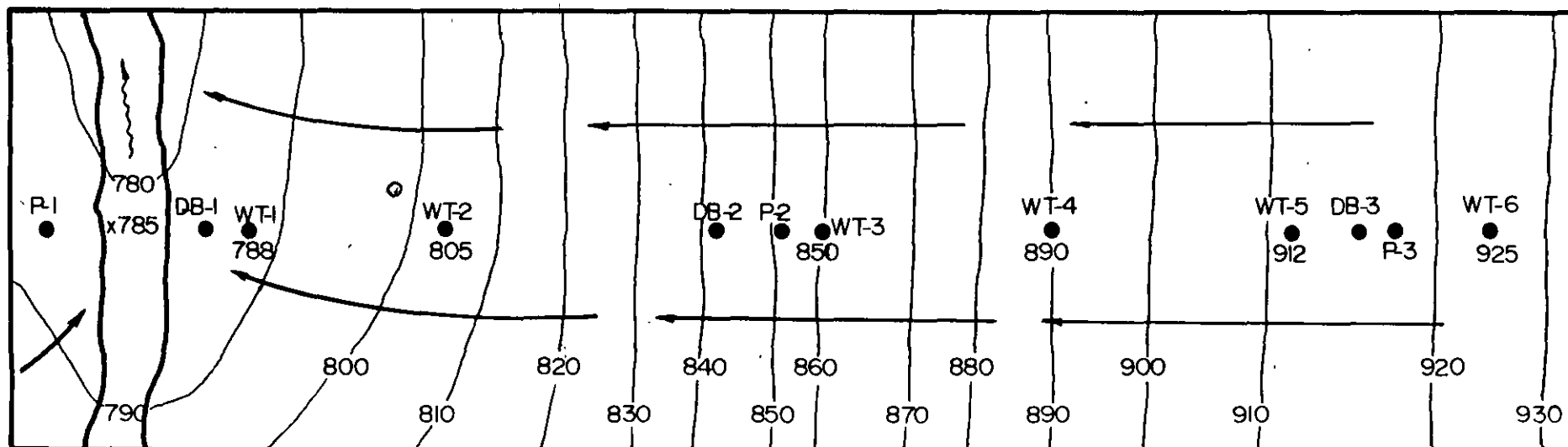

(b)

Efecto de la medición de niveles en áreas de recarga y descarga: a) configuración incorrecta considerando medición de niveles en pozos que no reflejan la superficie piezométrica; b) configuración correcta después de eliminar mediciones de no representativas. (Saines, 1981).

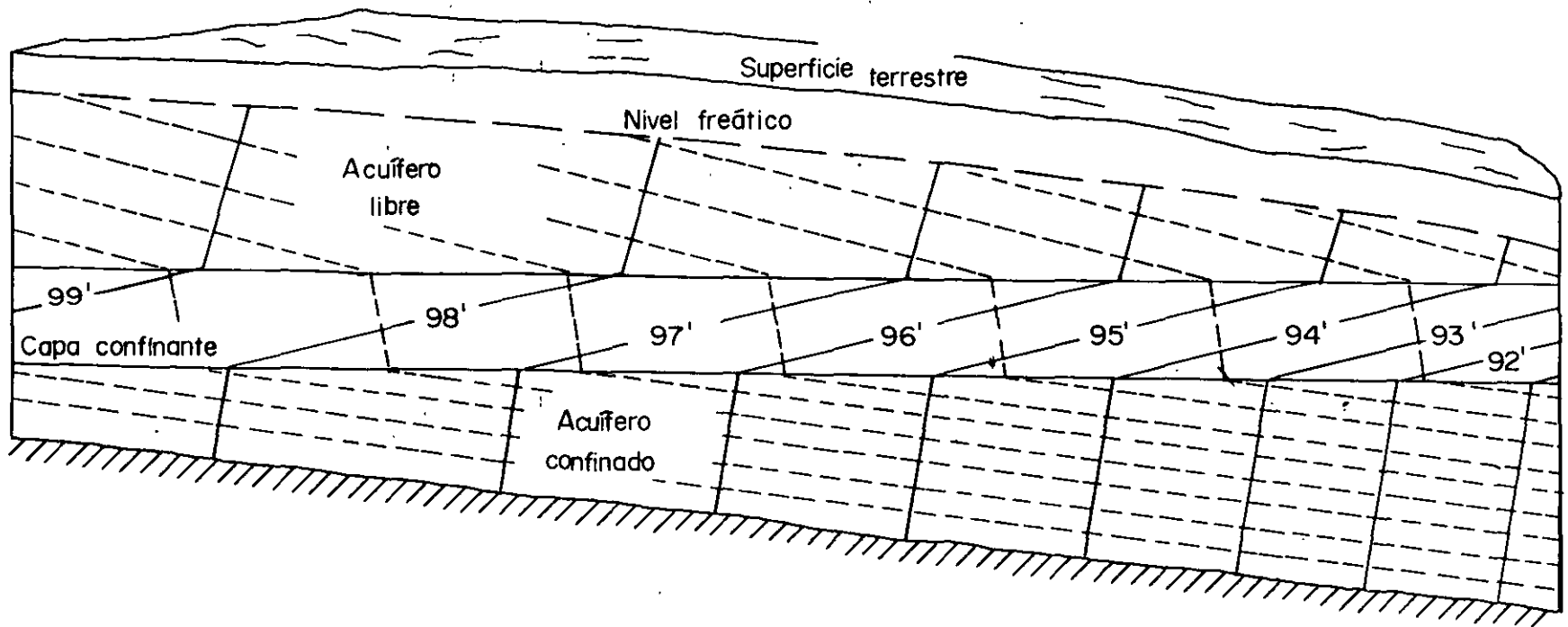

Las líneas de flujo en los acuíferos tienden a ser paralelas pero en las capas confinantes son casi perpendiculares a las fronteras (*Referencia: Heath, 1983*).

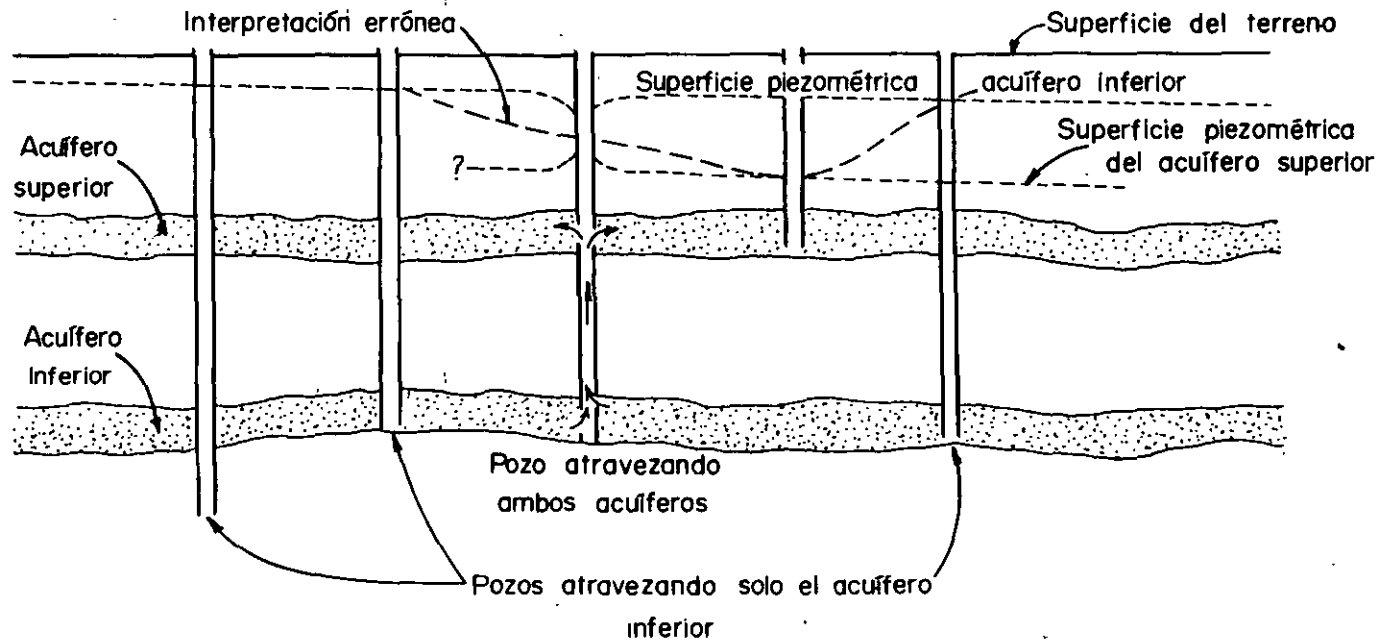

Error en la medición de la superficie piezométrica debido a la combinación de niveles en dos acuíferos confinados con diferente carga hidráulica. (Davis and DeWiest, 1966).

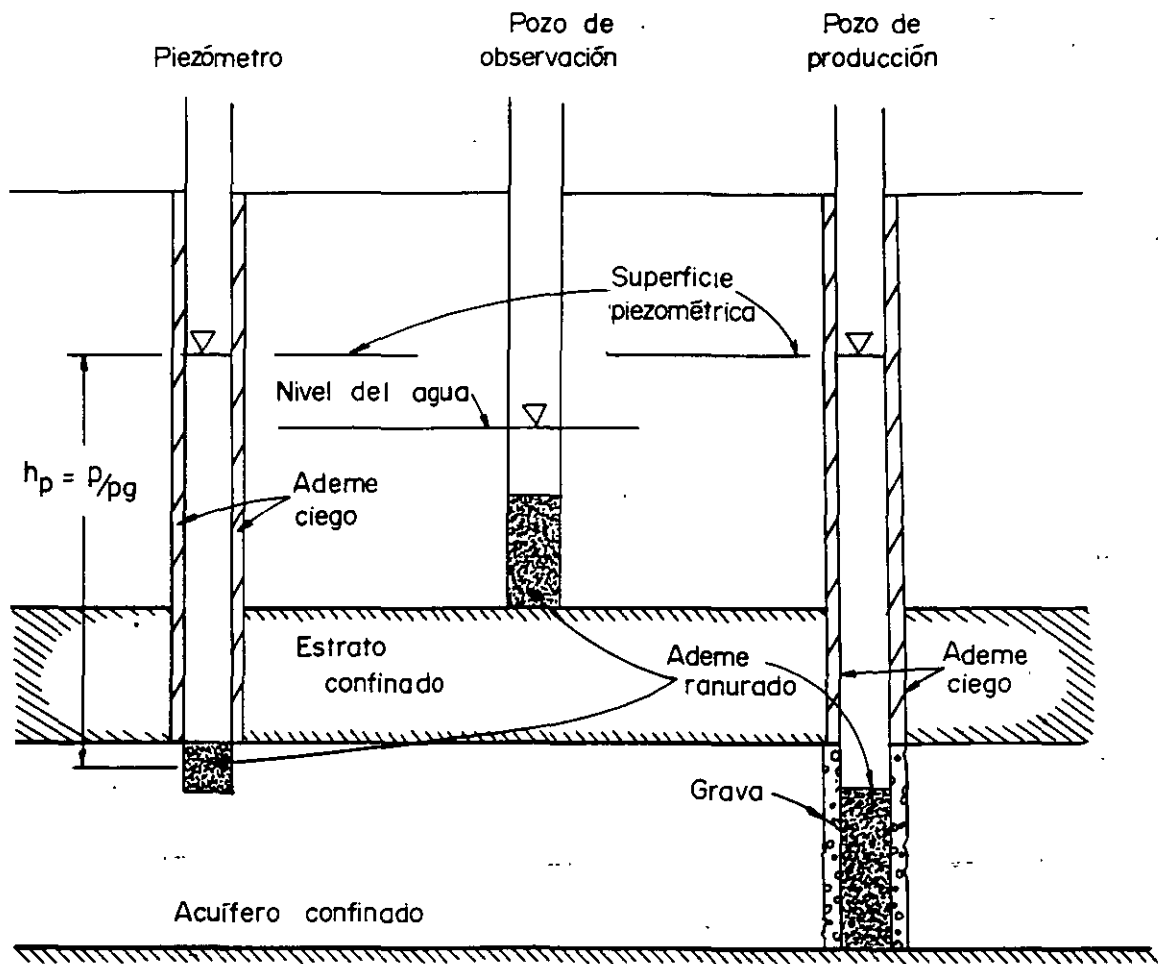

Dispositivos para medir los niveles de agua en los acuíferos.
 (McWhorter y Sunada, 1976).

Área de recarga

Diagrama transversal mostrando el nivel del agua medido por piezómetros localizados a varias profundidades. (Mills et al., 1985).

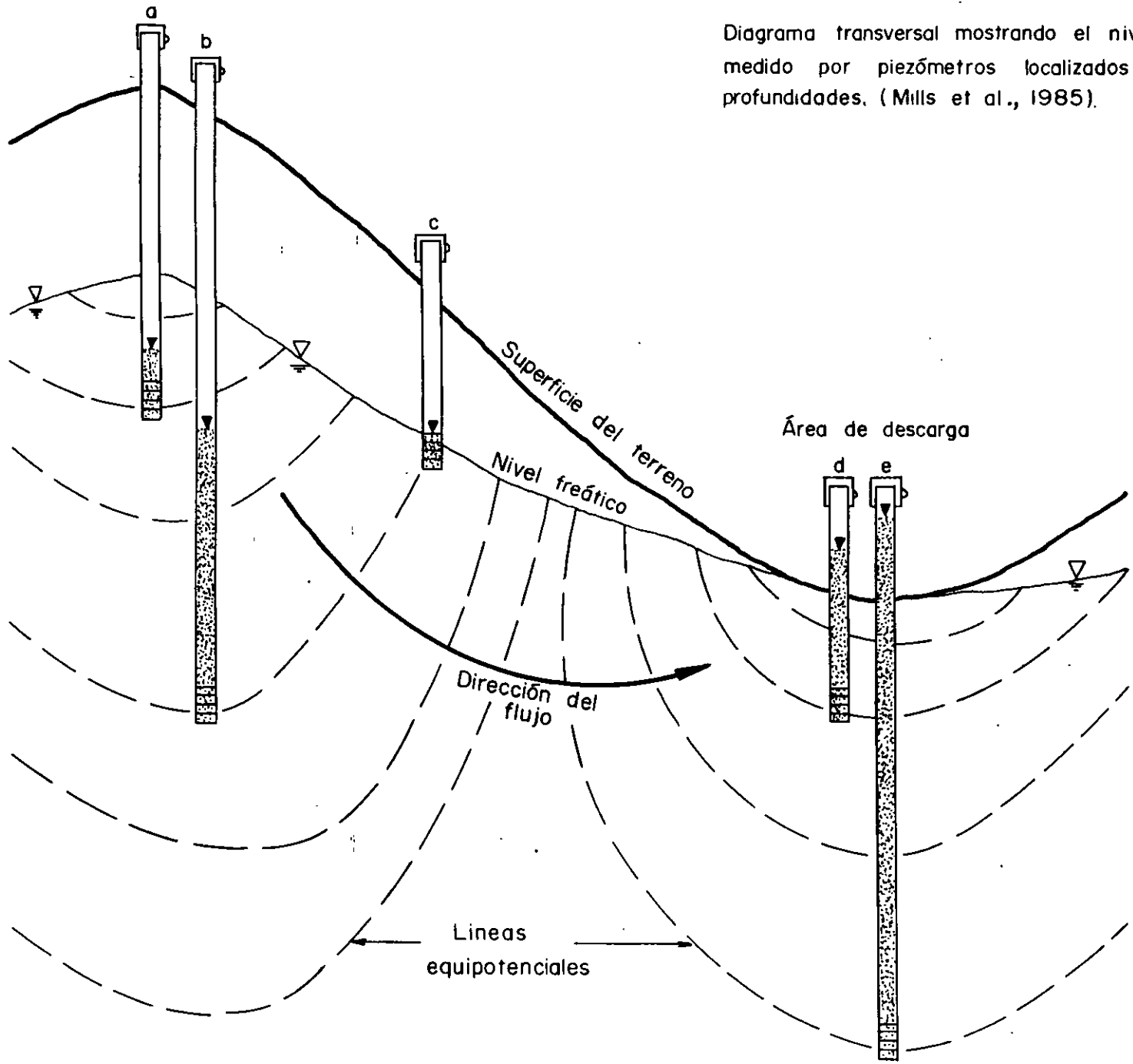

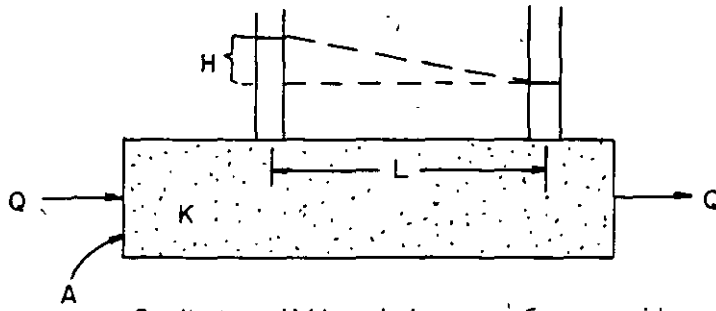

Gradiente = $H/L = i$, la energía requerida para mover el agua L.

$Q =$ Flujo (gpd).

$A =$ Area transversal (ft^2)

$K =$ Conductividad hidráulica = gpd ft

Tubo vertical con flujo ascendente

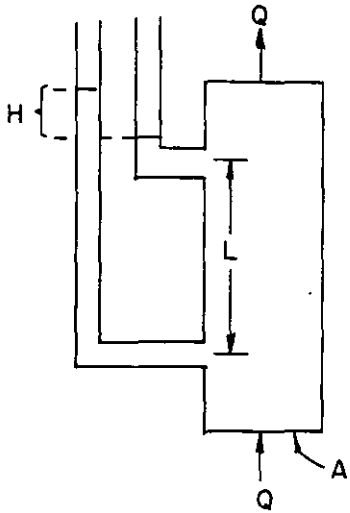

Tubo vertical con flujo descendente

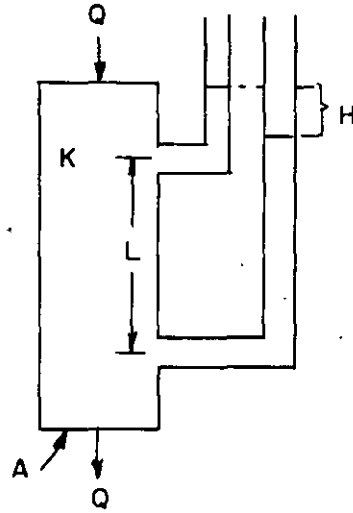

Condiciones de campo

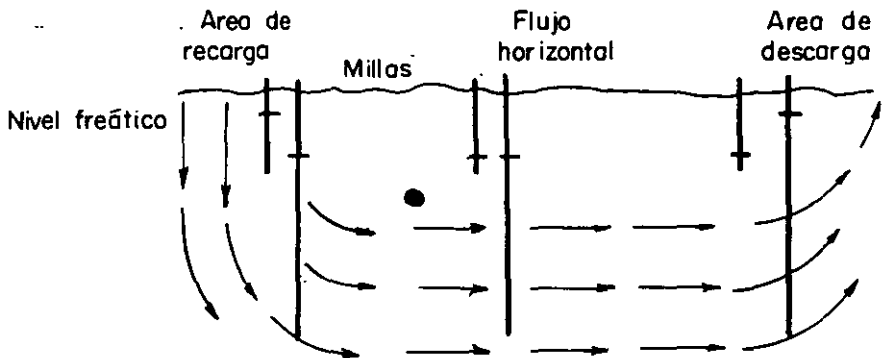

Explicación gráfica de la ley de Darcy.

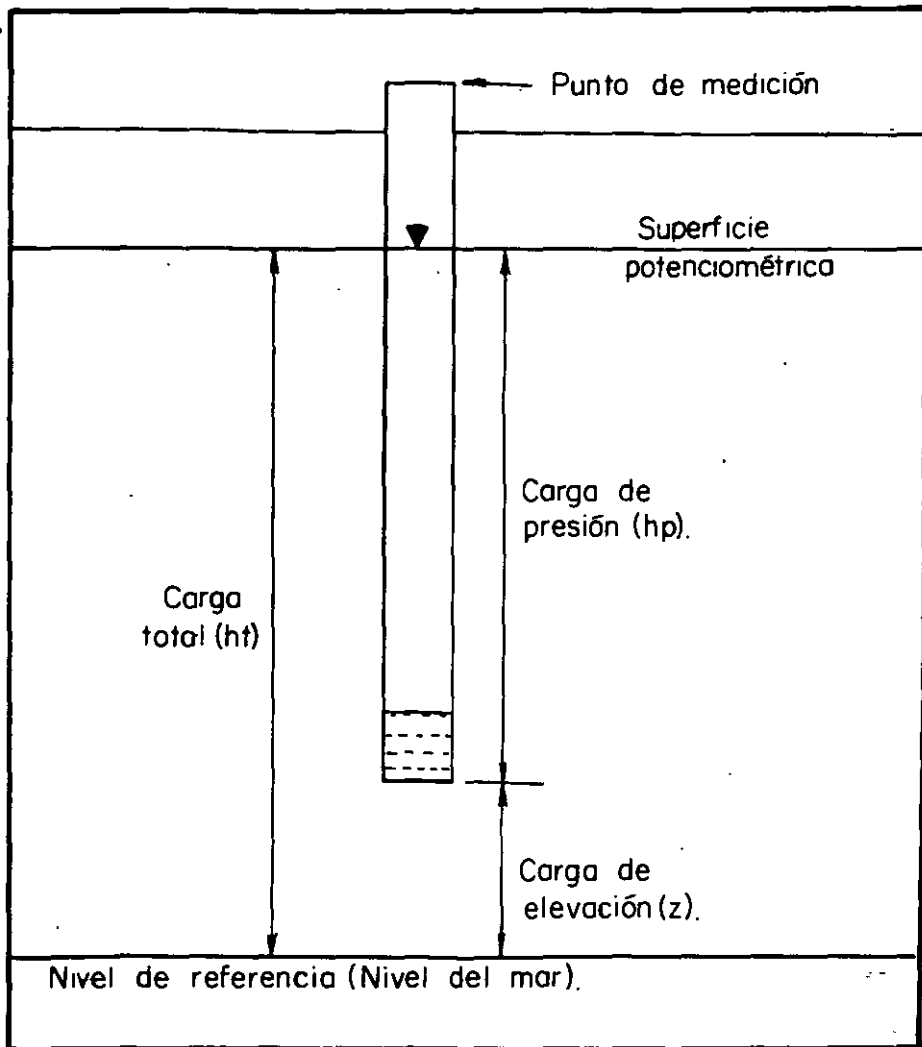

Relación entre carga hidráulica total, carga de presión y carga de elevación.

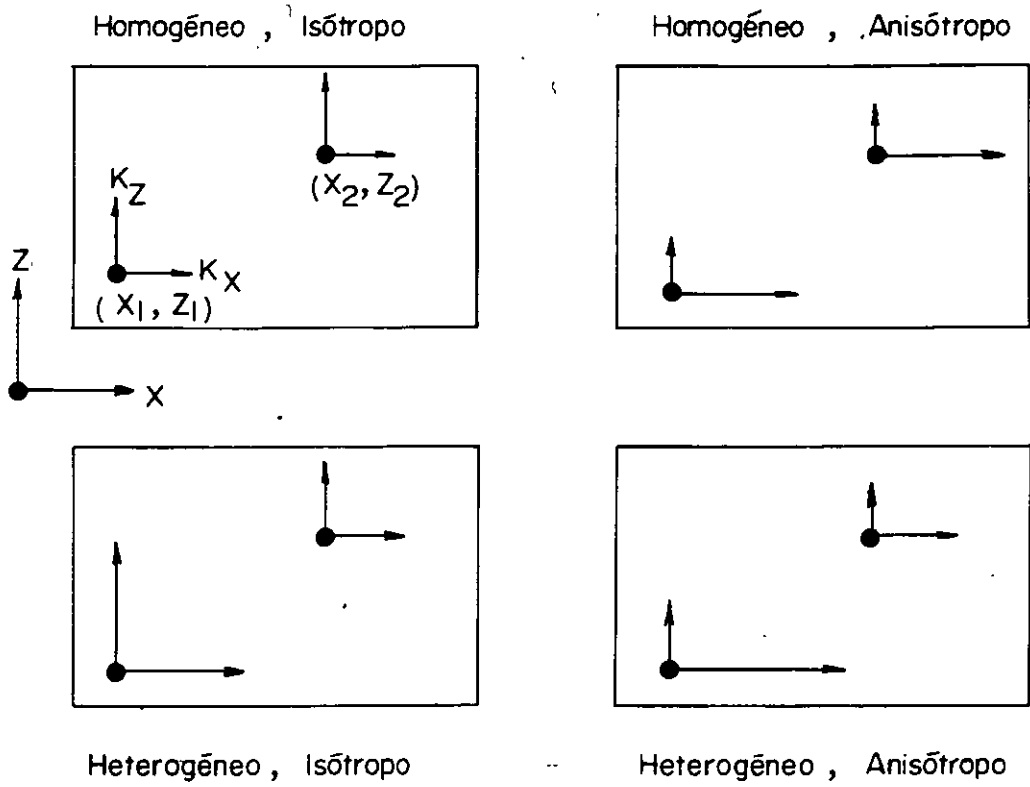

Heterogeneidad y Anisotropía: Cuatro posibles combinaciones

(Freeze and Cherry, 1979)

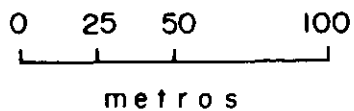
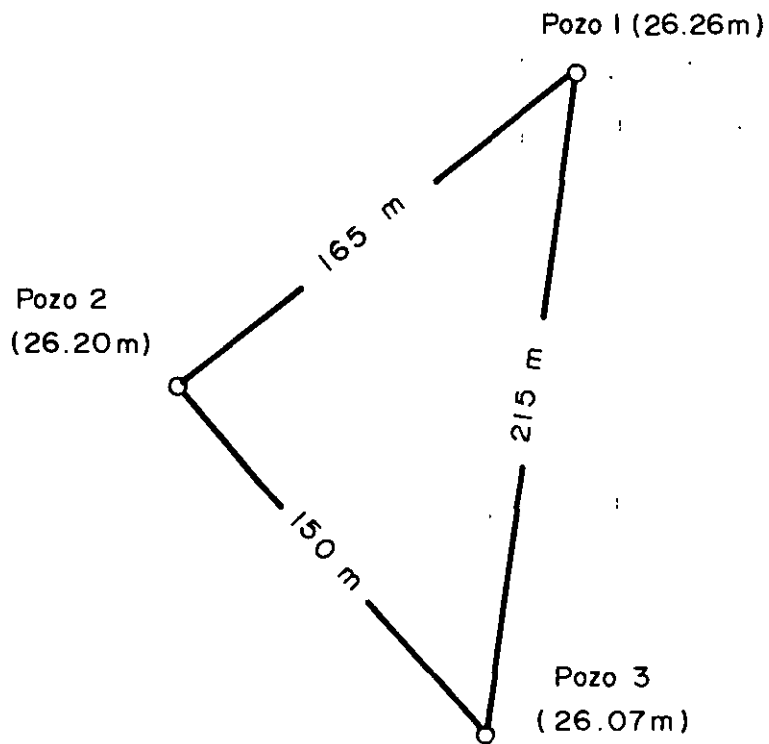

$$(b) \frac{(26.26 - 26.20)}{X} = \frac{(26.26 - 26.07)}{215}$$

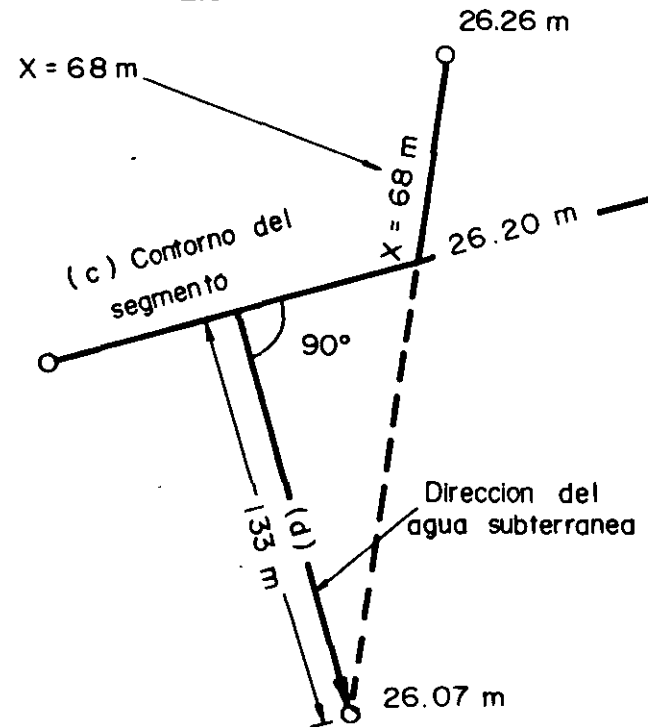

(a) Pozo 2
W.L. = 26.20

$$(e) \frac{26.2 - 26.07}{133}$$

$$\frac{h}{L} = \frac{0.13 \text{ m}}{133 \text{ m}}$$

Procedimiento alternativo para determinar las líneas equipotenciales y la dirección del flujo subterráneo en un acuífero homogéneo e isótropo. (Heath, 1983).

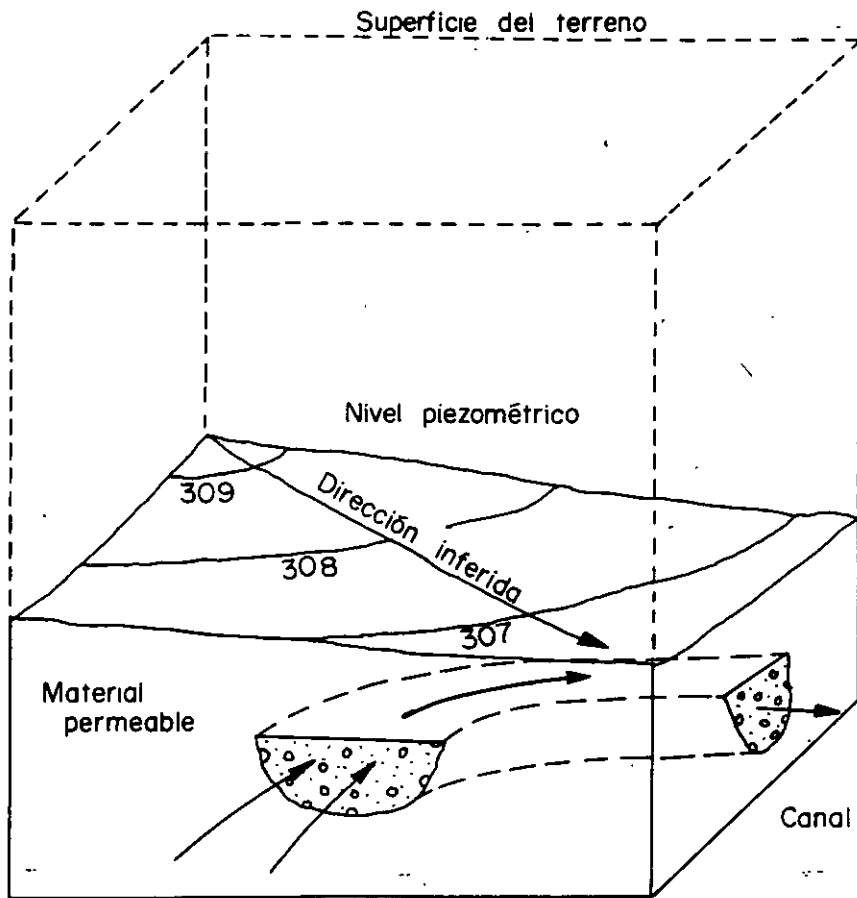

Movimiento perpendicular
a la dirección inferida

Divergencia en la dirección inferida del flujo subterráneo debido a la heterogeneidad del medio. (Davis et al., 1985)

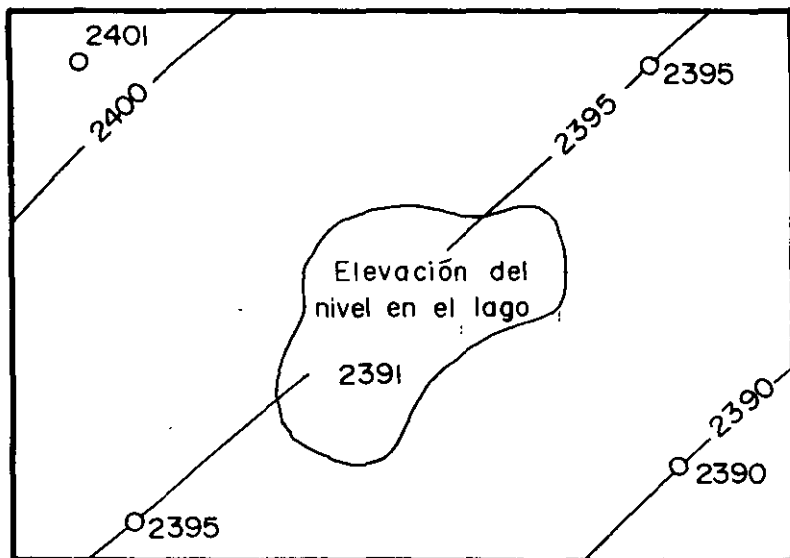

Incorrecto

(a)

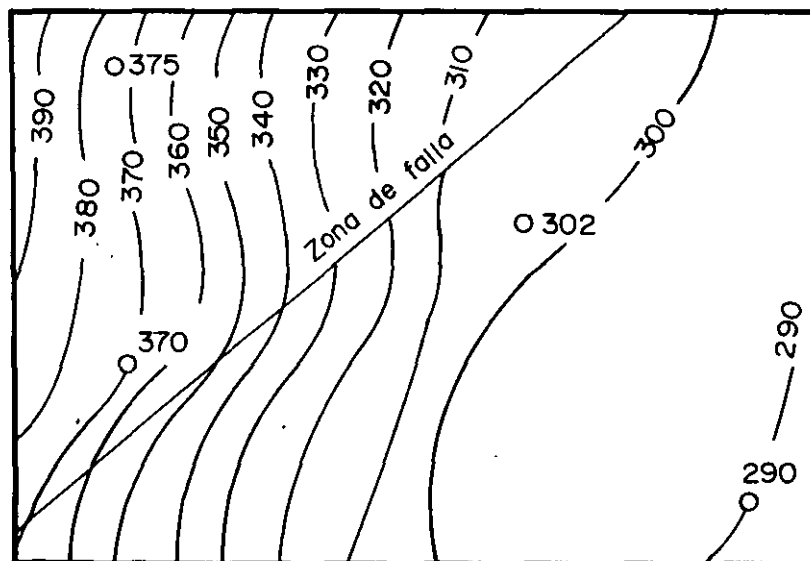

Incorrecto

(b)

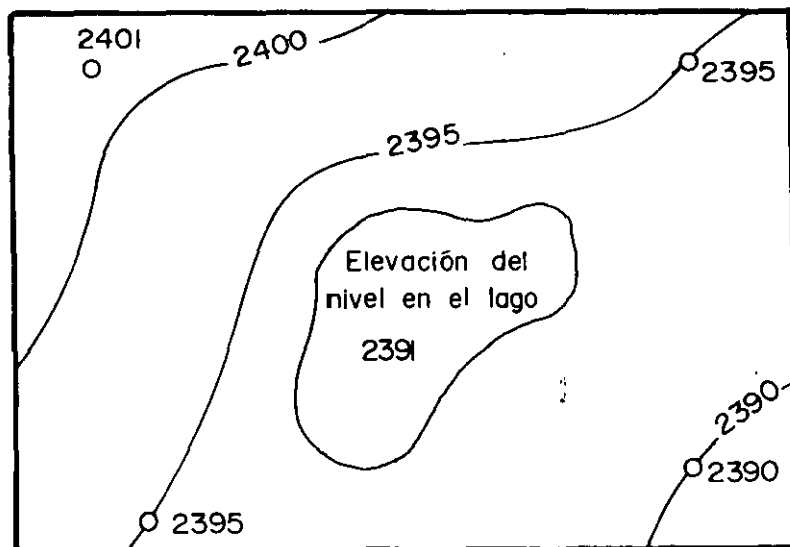

Correcto

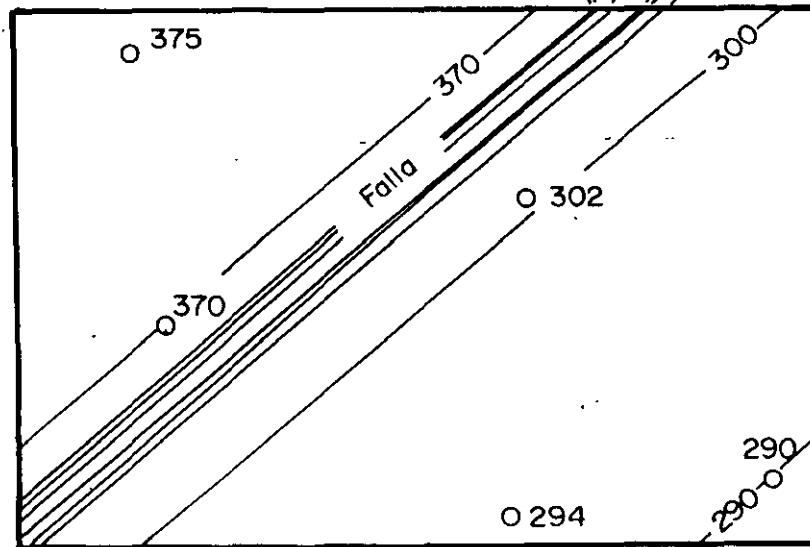

Correcto

Errores en la configuración de mapas piezométricos; (a) depresión topográfica ocupada por cuerpos de agua superficial, (b) zona de falla. (Davis and DeWiest, 1966)

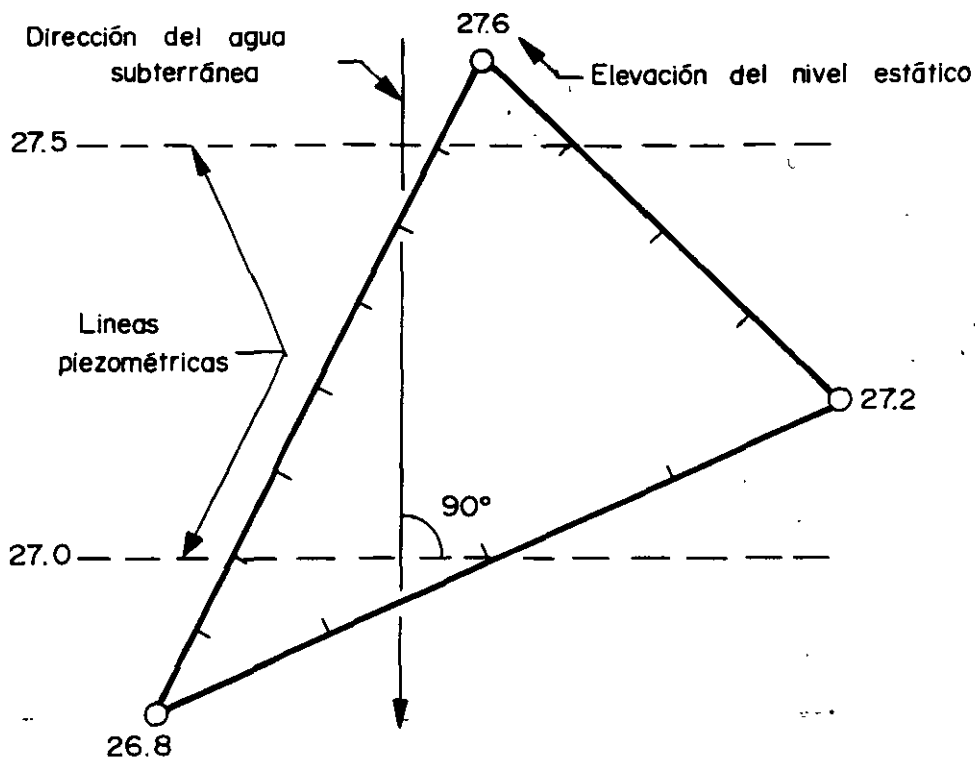

La dirección del movimiento del agua subterránea puede ser determinada a través de la medición del nivel del agua en tres pozos de la misma profundidad. (Heath y Trainer, 1981)

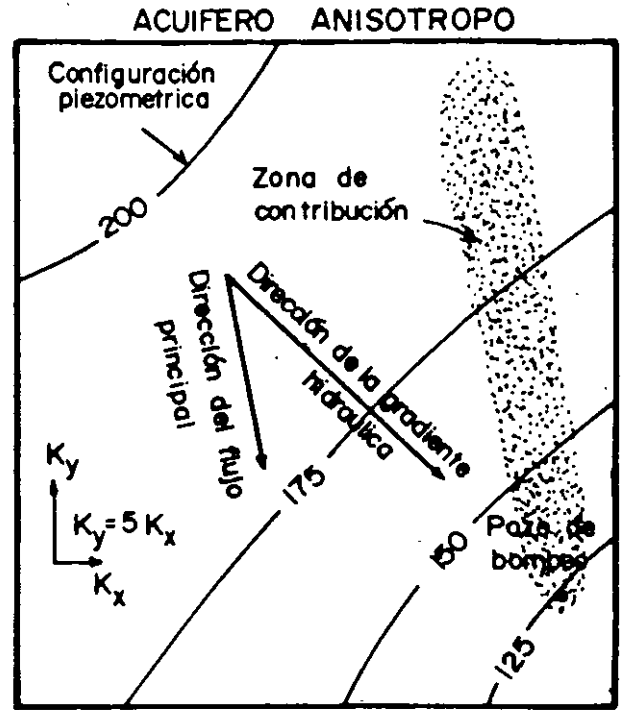
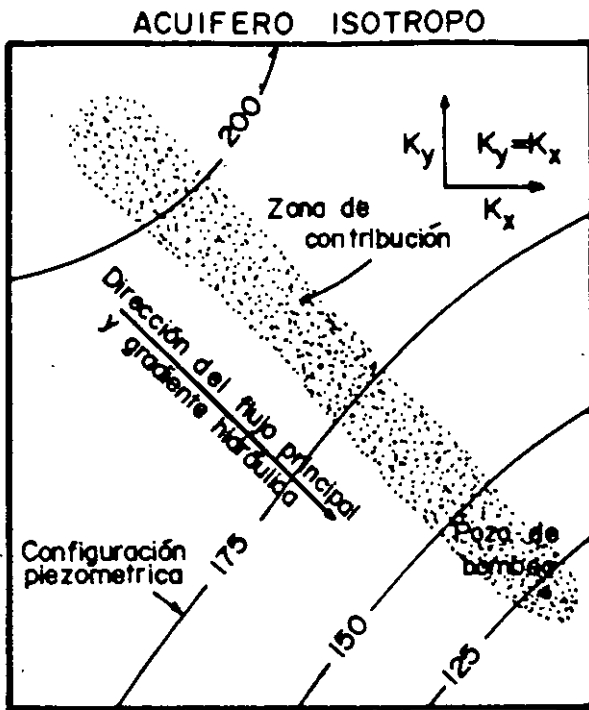

A. Efecto de la anisotropía en la orientación de la zona de contribución.

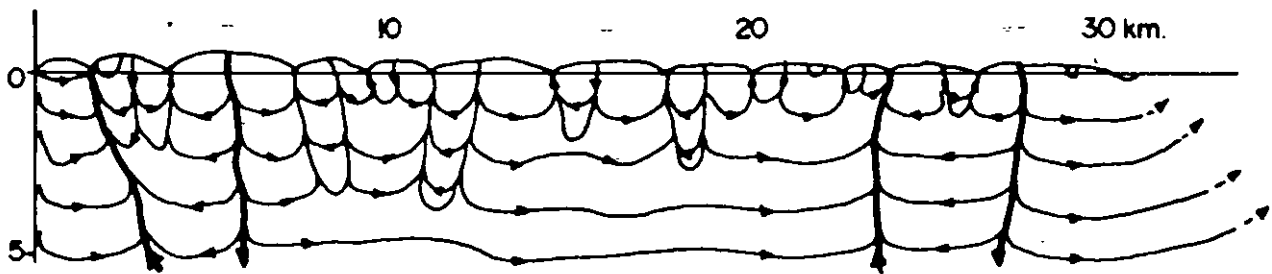

B. Simulación numérica de las líneas de flujo en un sistema de rocas fracturadas. (Gale, 1982)

Efecto de las fracturas sobre el movimiento de las aguas subterráneas.

DISTRIBUCION DE LA CONCENTRACION AL TIEMPO $t=0$

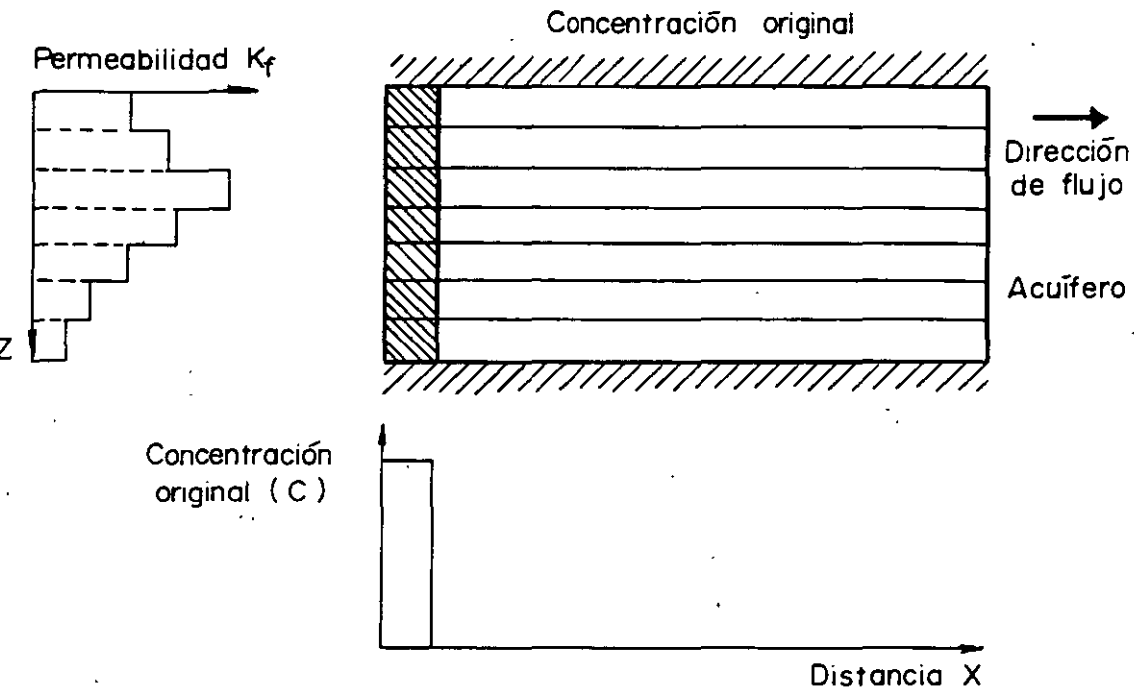

DISTRIBUCION DE LA CONCENTRACION AL TIEMPO $t > 0$

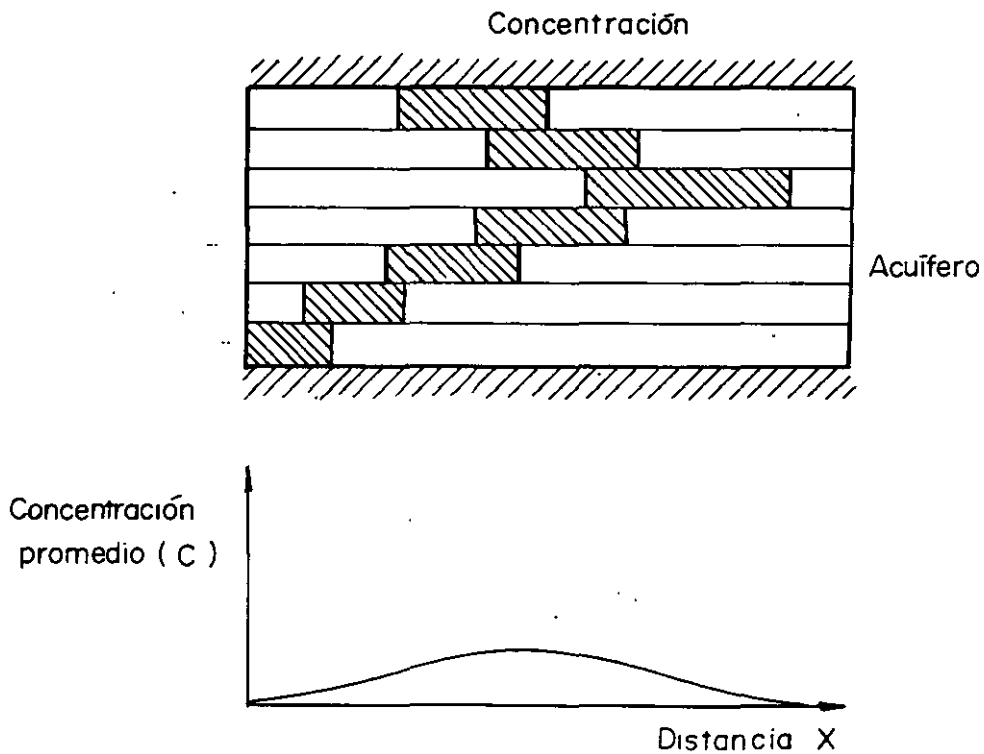

Representación esquemática del proceso de macrodispersión en un acuífero multicapas.

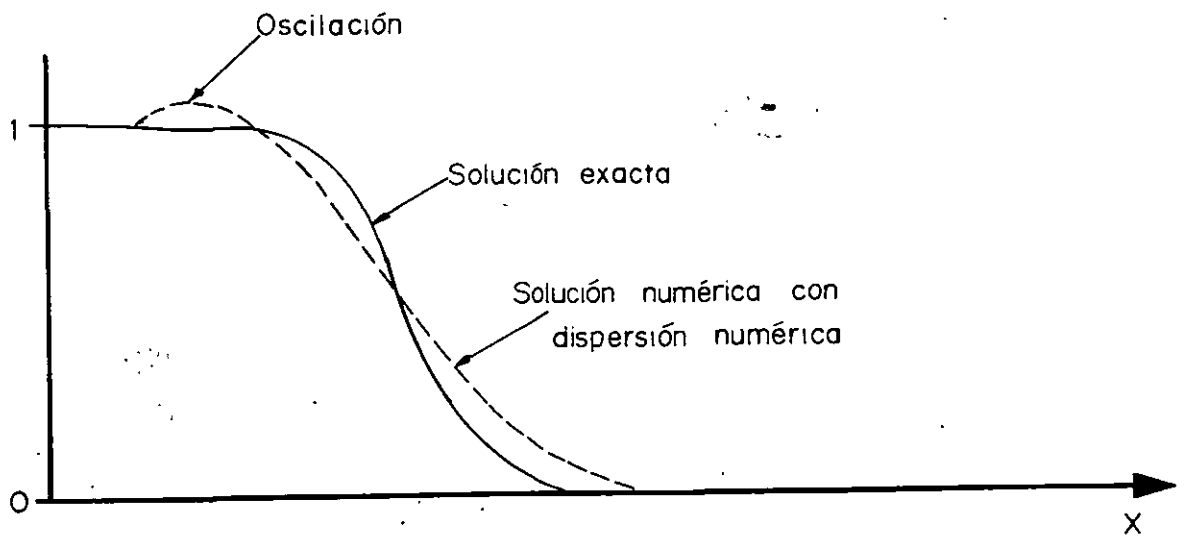

Dispersión numérica y oscilaciones.

Velocidad promedio de poro en un volumen representativo

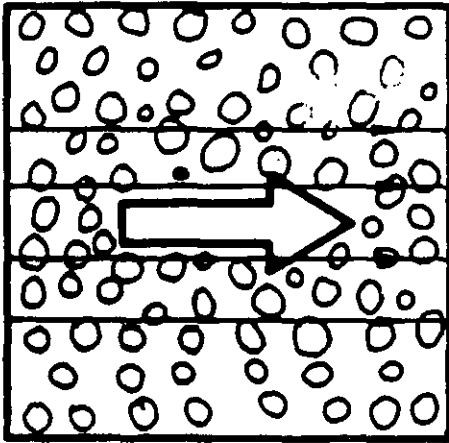

Distribución promedio de la concentración inicial (transporte por advección).

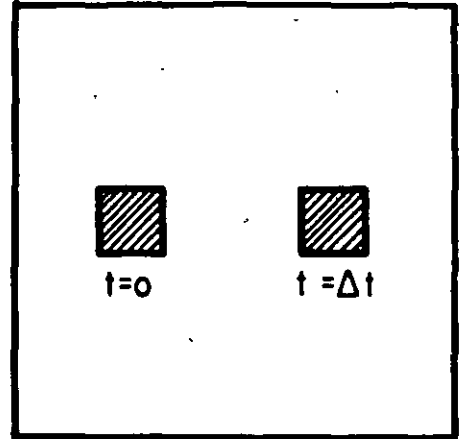

Flujo preferencial

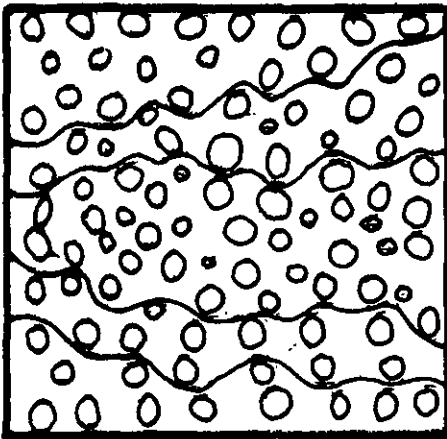

Transporte (advección + dispersión)

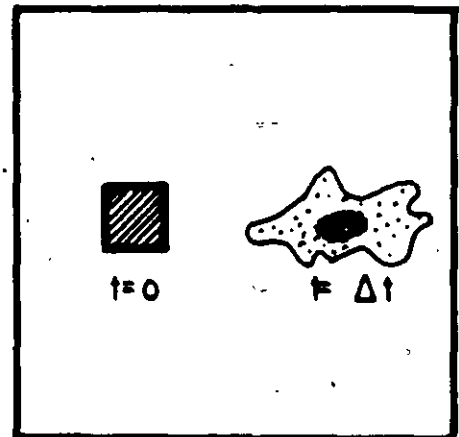

Representación esquemática de la dispersión